

# HG 60-2

# HG 60-2

**NOTICE D'UTILISATION**  
**OPERATING INSTRUCTIONS**  
**MODO DE EMPLEO**  
**GEBRAUCHSANWEISUNG**  
**ISTRUZIONI PER L'USO**

**GEBRUIKSHANDLEIDING**  
**MANUAL DE UTILIZAÇÃO**  
**INSTRUKCJA UŻYTKOWANIA**  
**使用说明书**  
**HASZNÁLATI ÚTMUTATÓ**

Notice à conserver  
Keep these instructions  
Bitte bewahren Sie diese Hinweise auf  
Istruzioni da conservare  
Conservar instrucciones  
Bewaar deze handleiding  
Instruções a conservar  
Bevar vejledning  
Zachowaj instrukcję  
请妥善保存说明书  
Őrizze meg a használati útmutatót

Réalisation : EVOLUTION + 32 / 69 250 500

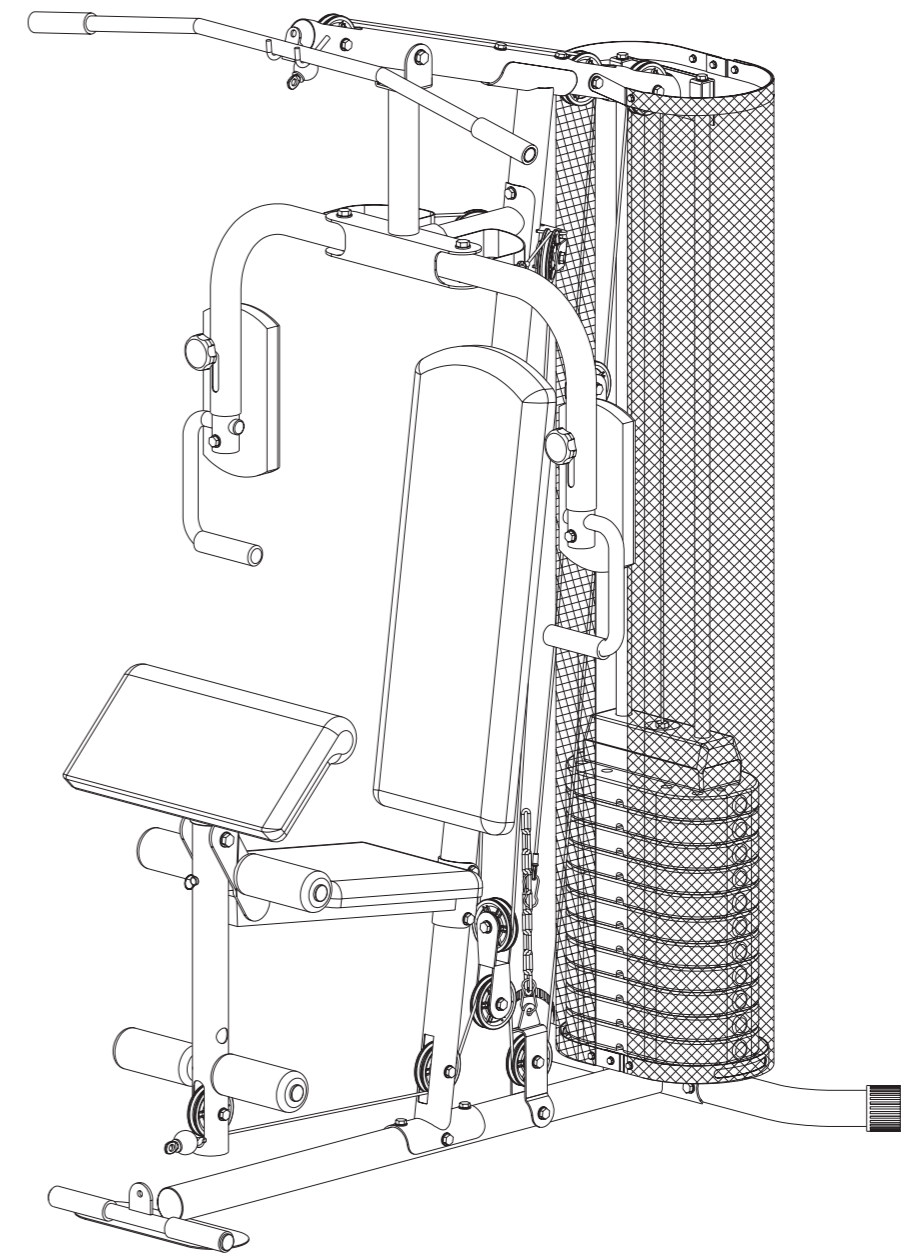

  
**DOMYOS**

**DOMYOS**

decathlon  
creation©

DECATHLON - 4, Boulevard de Mons - 59665 Villeneuve d'Ascq - France  
[www.decathlon.com](http://www.decathlon.com) Made in China - Hecho en China - 制造中国



Réf. pack : 526.316 - CNPJ : 02.314.041/0001-88

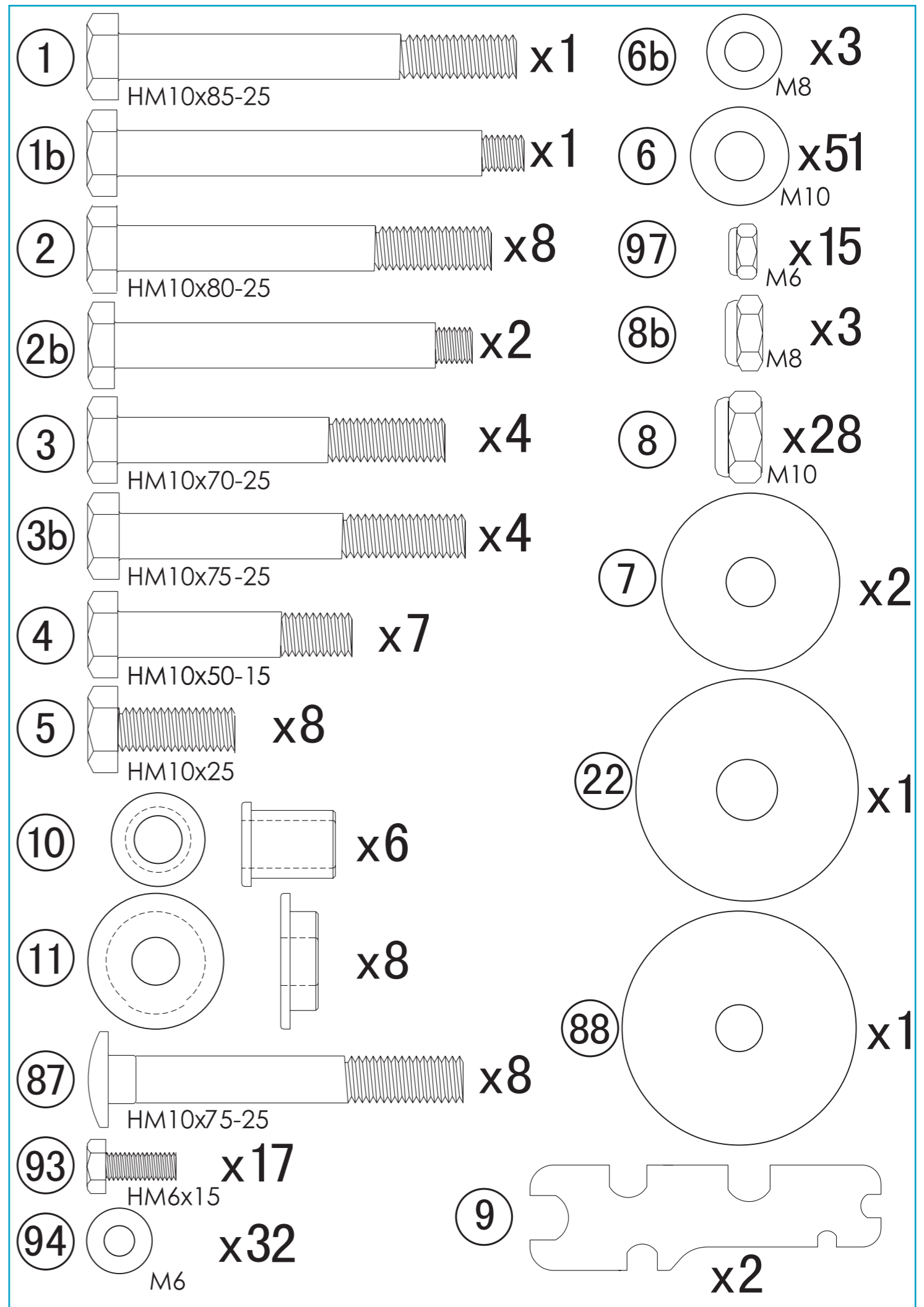

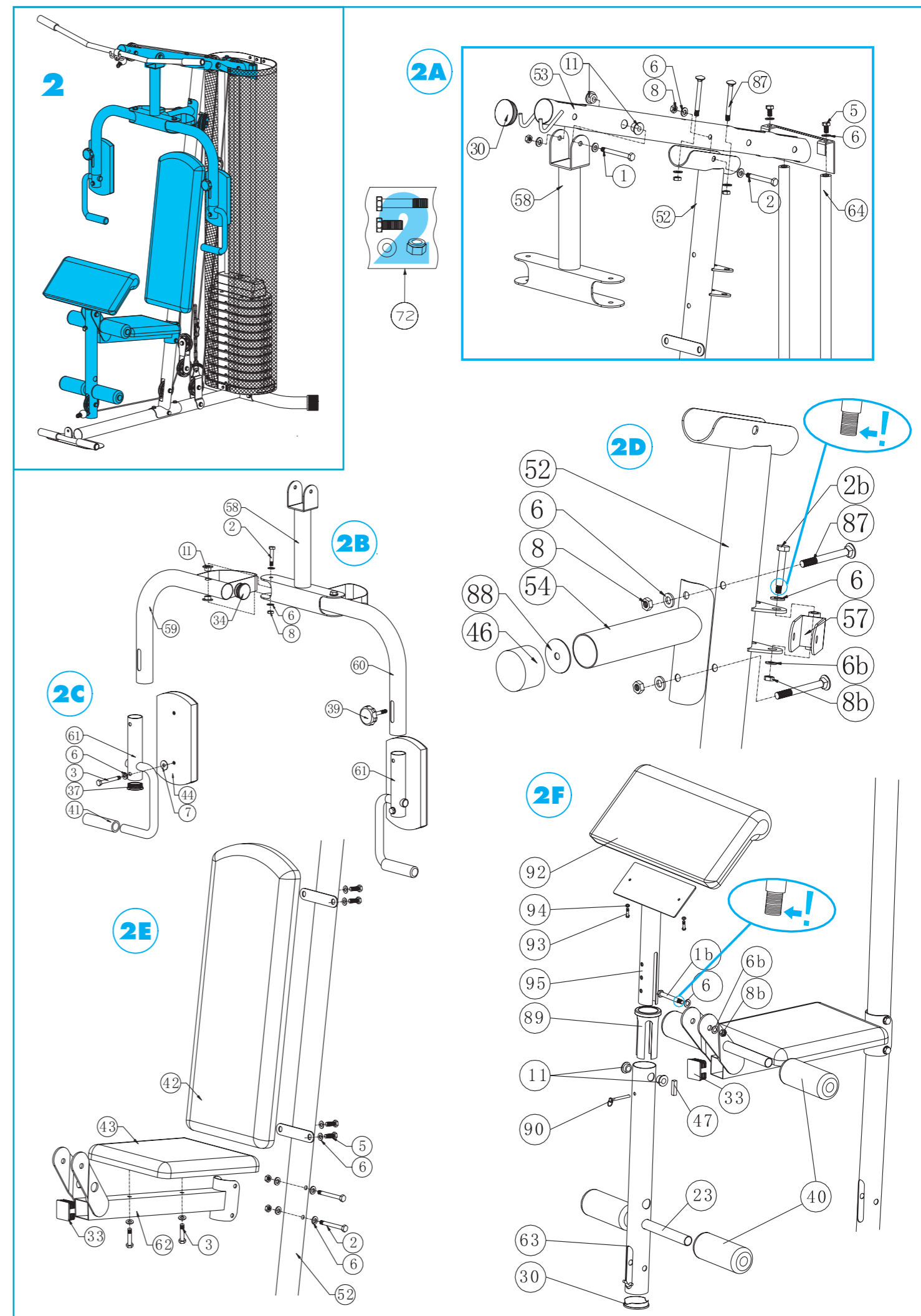
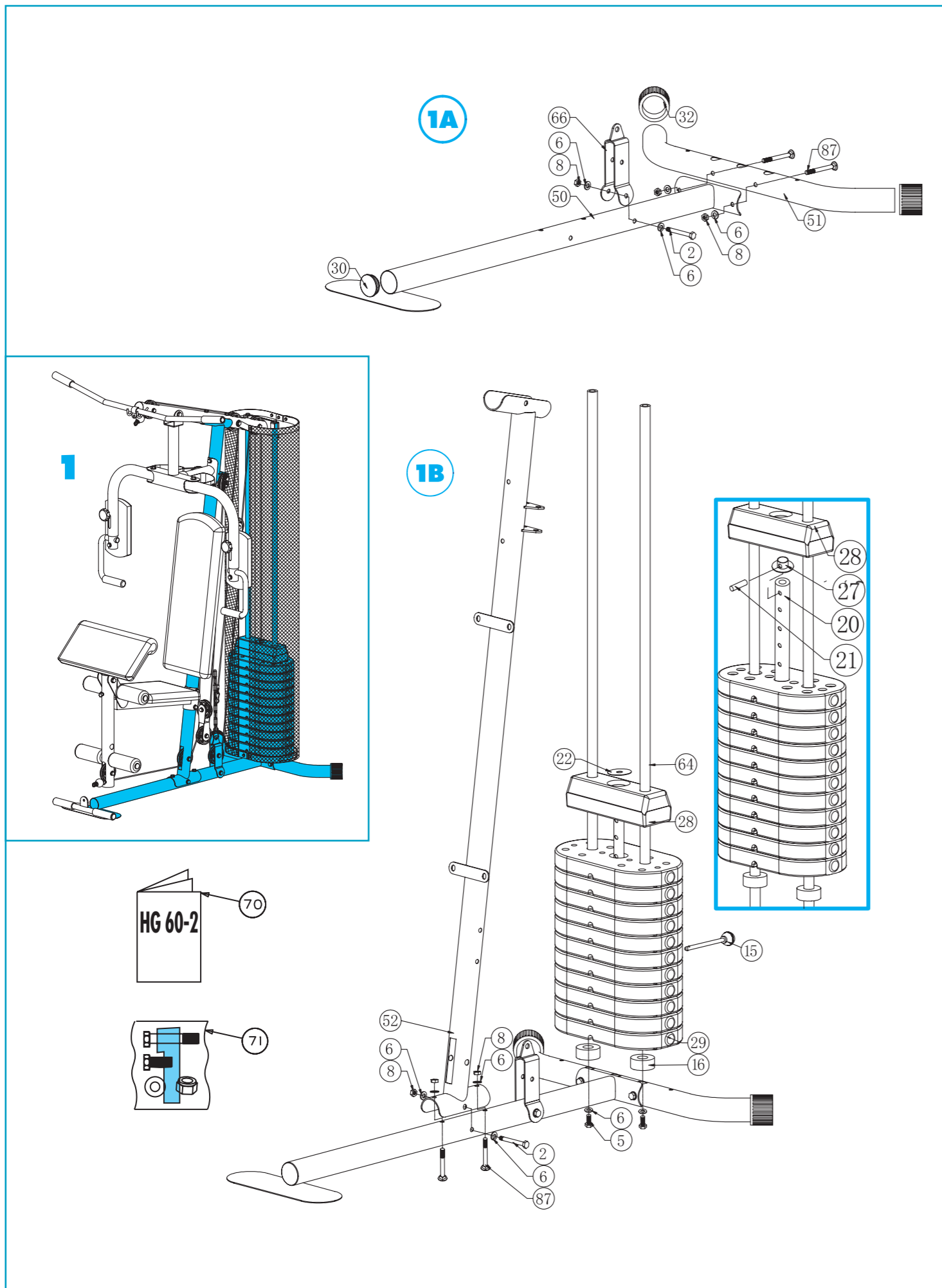

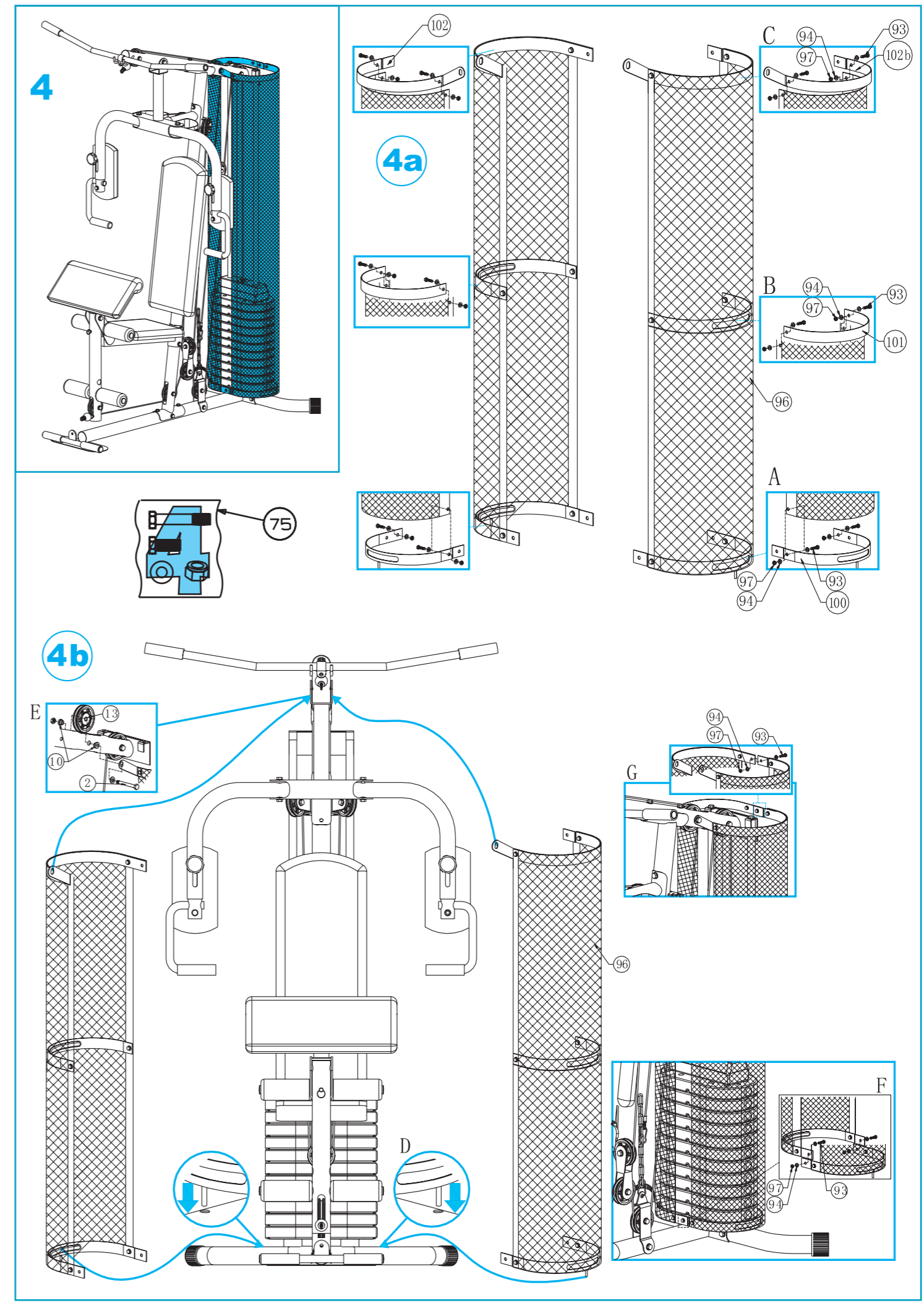
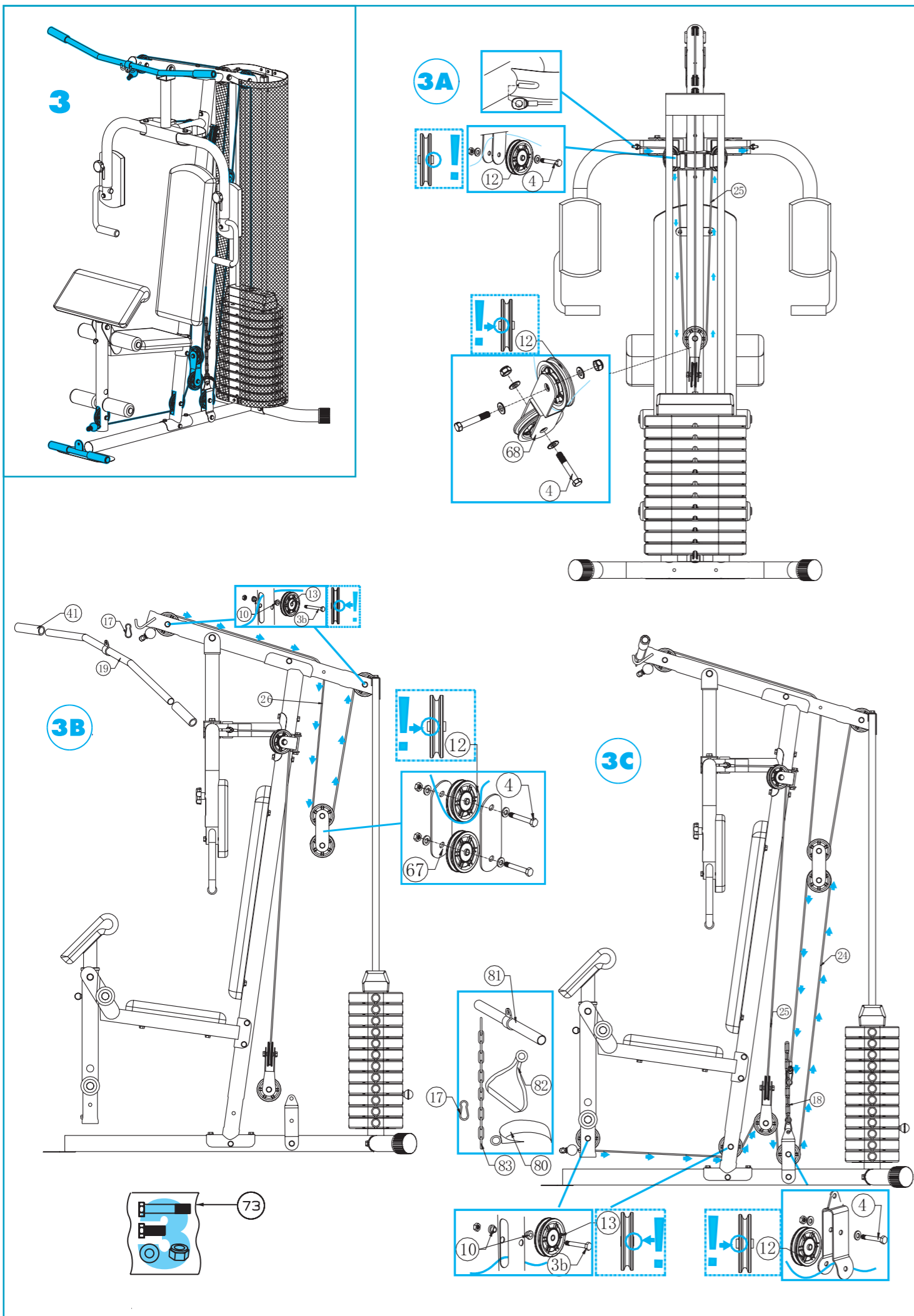

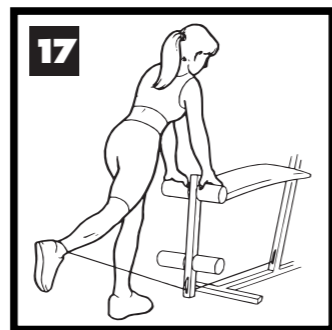
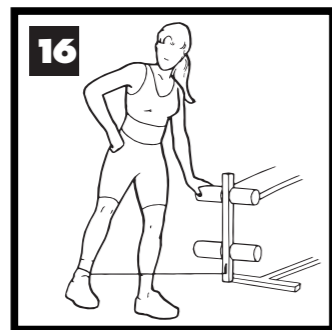
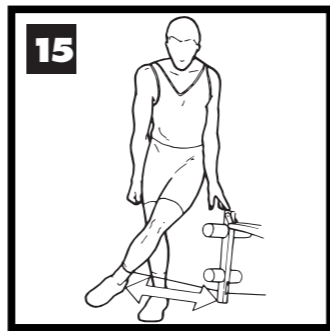
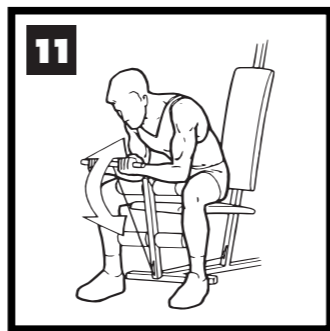
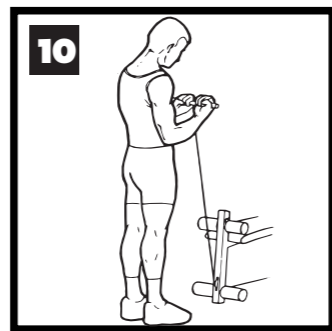
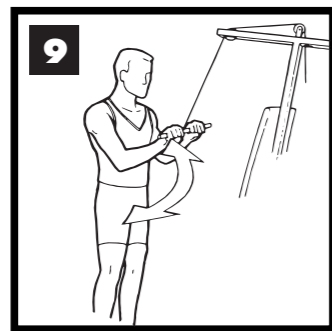
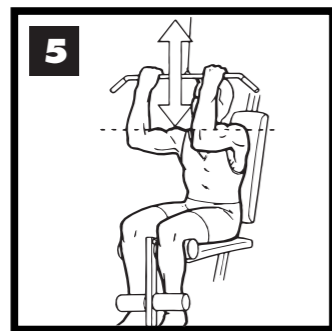
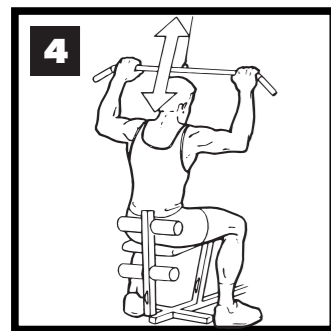
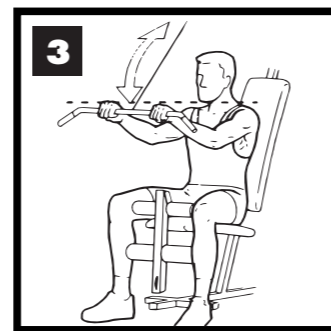
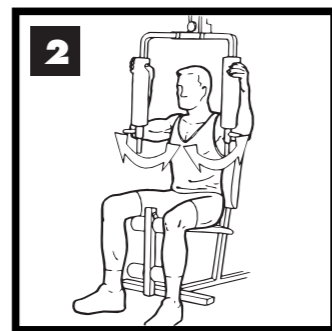

You have chosen a DOMYOS fitness machine and we wish to thank you for the trust you place with us. We created the DOMYOS brand to enable all sports aficionados to remain at peak fitness. This item was designed by sportsmen for sportsmen and women. We would very much appreciate receiving any of your comments and suggestions about DOMYOS products. To this aim, the staff at your local store and the DOMYOS design department are at your disposal. If you wish to write to us, you can send us email at the following address: domyos@decathlon.com. We wish you enjoyable training sessions and hope that this DOMYOS item be a source of pleasure for you.

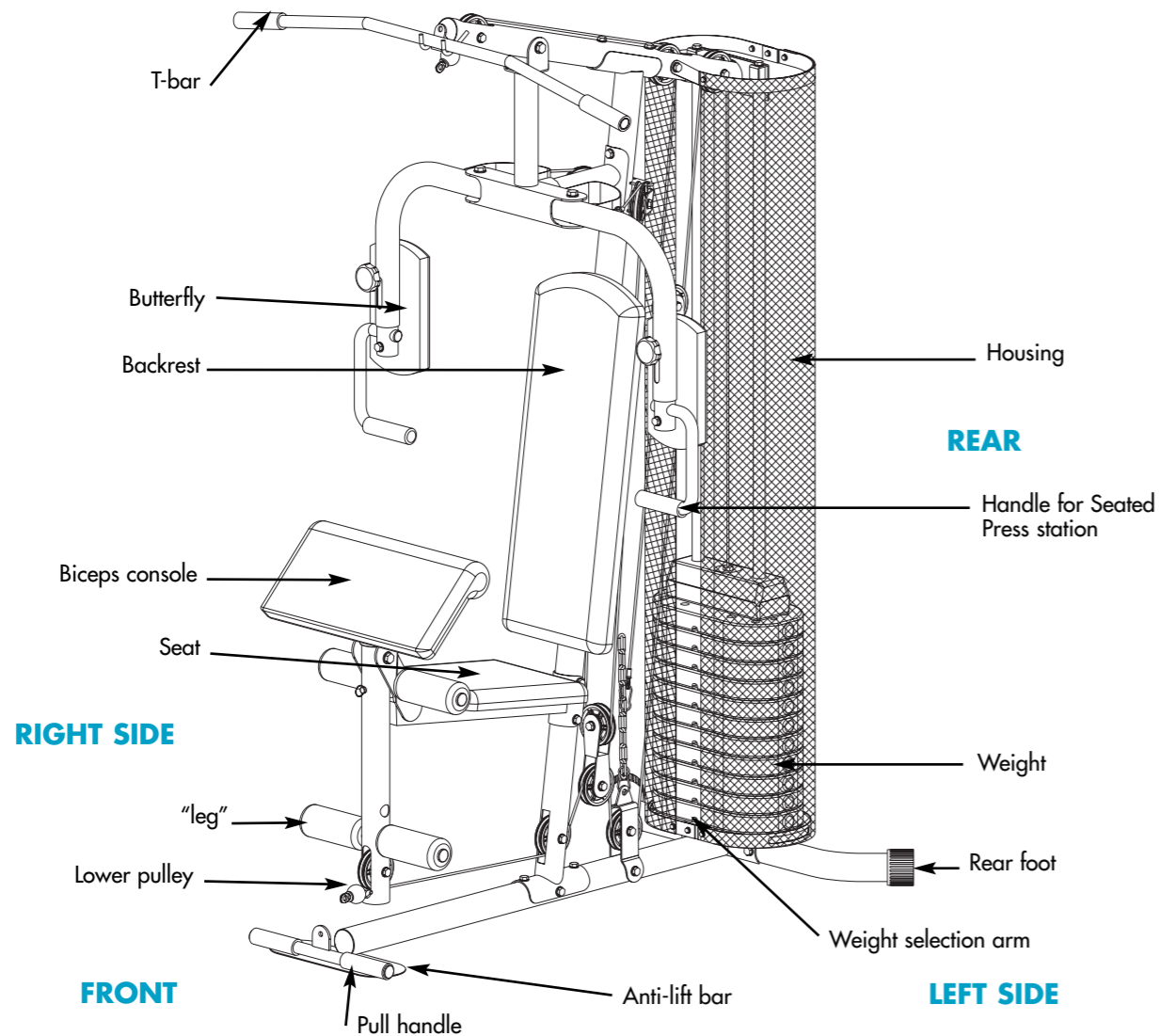

|  |  |                                 |
|--|--|---------------------------------|
|  | <b>HG 60</b>   | <b>128 kg</b><br><b>282 lbs</b> |
|  | 1620 x L 1020 x H 2070 cm<br>  63 x L 40 x H 81 inch |                                 |

**Model N° :** \_\_\_\_\_  
**Serial N° :** \_\_\_\_\_  
 Write the serial number in the space above for future reference.

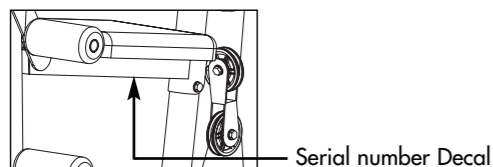

## CAUTION

- Read all warnings affixed to the product.
- Read precautions and instructions in this manual before using this equipment.
- Keep this manual for future reference.

## PRESENTATION

The HG 60 is a compact and multipurpose body work appliance. Training on this type of appliance aims at toning up all of your muscles and improving your physical fitness by locally working on each muscle. Its great resistance allows the HG 60 to accompany you in your progress.

## SAFETY

**Warning: to reduce the risk of serious injury, please read the important precautions below before using the product.**

1. Read all the instructions in this manual before using the product. Use this product only in the way described in this manual. Keep this manual during the product's service life.
2. An adult should do the assembly of the appliance. This appliance should be assembled without haste.
3. It is up to the owner to make sure that all of the product's users are properly informed on all the user precautions.
4. DOMYOS disclaims all responsibility concerning claims for injury or for damages suffered by any persons or property arising from the normal or abnormal use of this product by the purchaser or by any other person.
5. The product is intended for domestic use only. Do not use the product in a commercial, rental or institutional context.
6. Use the product indoors, away from moisture and dust, on a level and solid surface and in a clear area. Be sure there is enough space for safe access to the HG 60 and passage around the product. Cover the floor beneath the product for protection.
7. It is the user's responsibility to ensure efficient maintenance of the appliance. After assembling the product and before each use, check that the attachment elements are well tightened without extending. Check the state of wear and tear parts.
8. In the event of damage to your product, have all worn out or defective parts replaced immediately by the After-Sales Service of your nearest DECATHLON store and do not use the product before it is completely repaired.
9. Do not store the product in a humid place (edge of swimming pool, bathroom...)
10. Always wear sports shoes to protect the feet while exercising. Wear appropriate clothing when exercising. DO NOT wear loose clothing that could get caught in moving parts. Remove jewellery.
11. Tie long hair so that it does not get in the way when exercising.
12. If you feel pain or dizziness while exercising, stop immediately, rest a while and consult your doctor.
13. Keep children and pets away from the product at all times.
14. Keep hands and feet away from moving parts.
15. Before starting an exercise program, you should consult a doctor to make sure that there are no counter-indications especially if you have not practiced any sport for several years.
16. Do not let setting devices extend outward.
17. Do not tinker with your HG 60.
18. Keep your back straight when using the product. Do not arch your back.
19. Any assembly or disassembly of the product must be performed with care.
20. Maximum user weight: 110 kg – 242 pounds.

## WARNING

Consult your doctor before starting an exercise program. This is particularly important for people over 35 or having had health problems before, and if you have not been working out for a long time. Read all the instructions before use.

## MAINTENANCE

To avoid perspiration damaging the saddle, use a towel or wipe the saddle after use. Slightly grease moving parts to improve their operation and avoid unnecessary wear.

The warning decals shown on this page have been placed on the product in the locations shown below. If a decal is missing or illegible, please contact your nearest DECATHLON store and order a free replacement decal. Place the decal on the product in the location shown.

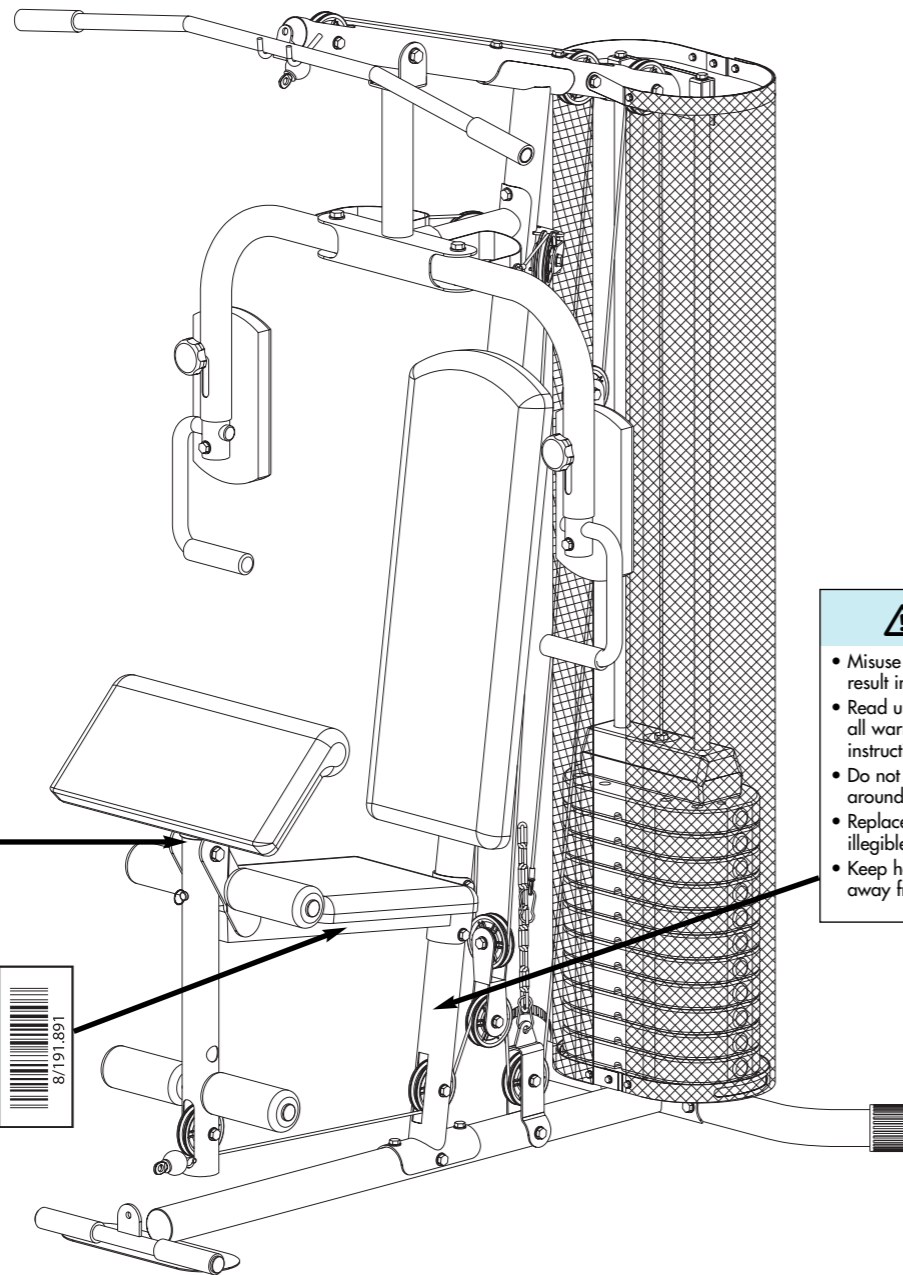
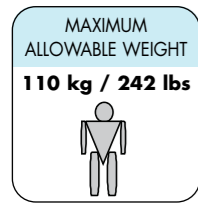

### WARNING

- Misuse of this product may result in serious injury.
- Read user's manual and follow all warnings and operating instructions prior to use.
- Do not allow children on or around machine.
- Replace label if damaged, illegible, or removed.
- Keep hands, feet and hairs away from moving parts.

### WARNING

Keep clear of this area.



## UTILIZATION

For optimal training, you are advised to follow these few recommendations:

- If you are a beginner, start by training for several weeks with light weights to accustom your body to body work.
- Warm up before each session with some cardiovascular work, series without weights or warm up and stretching exercises on the ground. Progressively increase the loads.
- Do all the movements with regularity, without jerks.
- For beginners, work in series of 10 to 15 repetitions, usually 4 series per exercise. Alternate the muscular groups. Do not work all the muscles every day but distribute your training.
- Always finish your training with a stretching session intended to relax the muscles worked on.

Training schedule example :

MONDAY: PECTORALS/TRICEPS  
TUESDAY: SHOULDERS/ABDOMINALS  
WEDNESDAY: BACK/BICEPS  
THURSDAY: REST  
FRIDAY: THIGHS/ABDOMINALS  
SATURDAY/SUNDAY: REST

## T H E E X E R C I S E S

Here are the basic exercises to harmoniously develop your muscles.  
For exercises using the low pulley the maximum load is 30kg - 66lbs.

## PECTORALS

### Sitting press (1)

**POSITION :** Set the height of the handles so they are at the level of your chest. Sit on the seat, lie your back flat against the back. Take hold of the horizontal or vertical handles.

**EXERCISE :** Breath in, push the press lever forwards breathing out, pull the press handle, breathing in without resting.

**MUSCLES WORKED :** pectorals, triceps, front shoulders.

### Butterfly (2)

**POSITION :** Sat on the seat, lie your back flat against the back. Place the forearms against the padded sleeves. Your arm should at a right angle to your chest.

**EXERCISE :** Breath in, push the sleeve breathing out with the inside of the forearms. Use the elbows rather than the hands to exercise pressure. Come back to the original position, breathing in and without resting the load.

**MUSCLES WORKED :** pectorals, triceps, major back muscles.

### Pull over (3)

**POSITION :** Sat properly straight on the seat, against the back. The arm slightly bent holding a latissimus bar, palms facing the ground, shoulder width apart.

**EXERCISE :** Breath in and fill your chest with air, drop your arms towards the thighs to shoulder level breathing out, come back up breathing in and expanding your chest. Your back must remain in a straight position against the back, the elbows must remain slightly bent.

**MUSCLES WORKED :** pectorals, triceps, major back muscles.

## DORSALS

### Neck pull (4)

**POSITION :** Seated facing the back rest, with the arms holding the latissimus bar with a wide grip.

**EXERCISE :** Pull the bar to the back of the neck while inhaling. Return slowly to the start position while exhaling, without resting. Do not pull the bar lower than your neck.

**MUSCLES WORKED :** Pectorals, dorsals (latissimus dorsi), back of the shoulders.

### Chest pull (5)

**POSITION :** Raise the seat back of the HG60 to 90°. Same exercise as above, but this time bringing the bar to the top of the chest. You may place your hands with a wide or tight grip, with the palm towards the bottom or towards the top.

**EXERCISE :** Keep your back flat while performing the exercise. Your back should not move during the exercise.

**MUSCLES WORKED :** Dorsals (latissimus dorsi), back of the shoulders.

### Lower pulley pull (6)

**POSITION :** Seated on the ground, the back straight, block your feet on the footrest of the apparatus.

**EXERCISE :** Grab the short bar with your palms facing the ground. While inhaling and filling your rib cage, bring the bar to the level of your navel, pulling your elbows towards the rear. Return to the start position while exhaling, without resting. Your chest should form a right angle in relation to your thighs during all the movements.

Do not lean forwards or backwards!

**MUSCLES WORKED :** Dorsals, back of the shoulders, lower part of the back. Also relies on the biceps.

## TRAPEZIUS

### (7)

**POSITION :** Standing, facing the HG60, with the feet resting on the metal plate, grab the short pulling bar fastened to the lower pulley, with the palm of your hands downwards.

**EXERCISE :** Bring the bar to the base of your neck while inhaling. Your elbows must be above your hands during the entire exercise.

**MUSCLES WORKED :** trapezius muscles, deltoids, participation of the biceps.

## SHOULDERS

### (8)

**POSITION :** Kneeling in profile to the front of the HG60, hold the pulling handle located in the lower pulley. The back should be kept straight throughout the exercise.

**EXERCISE :** Breathing out, bring the slightly bent arm up to shoulder level. Bring the weight back without posing it to chest level. Work in series, one shoulder after the other.

**MUSCLES WORKED :** External deltoids.

## TRICEPS

### (9)

**POSITION :** Standing, facing the HG60. The knees slightly bent or one foot slightly in front of the other to protect the lumbar region during exercise. The hands hold the short fixed bar on the high pulley. The palm of the hands facing the ground or upwards. The elbows should remain pressed against the torso throughout the movement.

**EXERCISE :** Pull the bar downwards breathing out. Bring it towards the chest breathing in. Only the forearms should move. The elbows and torso should not be part of the movement.

**MUSCLES WORKED :** Triceps.

### BICEPS

(10)

**POSITION :** Standing, facing the HG60, with the feet resting on the metal plate, your elbows firmly against your body. With the knees slightly bent or one foot slightly in front of the other, to protect the lumbar muscles during the exercise. Grab the short bar fastened to the low pulley with your hands, the palm of your hands pointed upwards.

**EXERCISE :** Bring the bar to your chest while exhaling. Bring the bar down-wards while inhaling. The elbows and trunk must not move during the exercise.

**MUSCLES WORKED :** biceps (arm flexors).

(11)

**VARIATION IN THE MOVEMENT :** sit down with your elbows placed on the preacher bench and curl the bar towards your chest whilst exhaling.

### FOREARMS

(12)

**POSITION :** In a seated position, the forearms on the biceps rest. Hold the short pulling bar located on the lower pulley. The palms of the hand should be facing downwards. (Possible variant: the palms facing downwards).

**EXERCISE :** Moving the wrists, push the bar up as high as possible, then return to the initial position as low as possible. The exercise must be done in complete amplitude. The wrists should be rotated. The forearms and arms should not move.

### THIGHS

Leg extension (13)

**POSITION :** In a seated position, the back wedged into the back. The hands firmly grip the bars on each side of the seat.

**EXERCISE :** Extend the legs breathing out. Come back to the initial position without letting the weight down. Do not lock the legs completely during an extension.

**MUSCLES WORKED :** Quadriceps.

Leg bending (14)

**POSITION :** Standing, facing the HG60, Place the front of the leg against the foam on the seat. Bring the foot behind the leg sleeve. Adjust the leg so that the sleeve is at ankle level, as close as possible to the heel. Slightly incline your chest forwards and hold the grips.

**EXERCISE :** One leg at a time, bring your heel as close as possible to your buttocks. Bring the leg back to the initial position without letting the weight fall. Your hip must not move during this exercise.

**MUSCLES WORKED :** ischio-tibial muscles.

Adductors (15)

**POSITION :** Standing, in profile in relation to the HG60 in the direction of the lower pulley, place the ankle strap on the leg closest to the apparatus.

**EXERCISE :** With the leg stretched, pull the leg towards the other leg, then go beyond it. Return to the start position.

**MUSCLES WORKED :** Adductors.

Adductors (16)

**POSITION :** Standing, in profile in relation to the HG60 in the direction of the lower pulley, place the ankle strap on the leg farthest from the apparatus.

**EXERCISE :** With the leg stretched, move the leg away from the other leg, then return to the start position.

**MUSCLES WORKED :** Abductors.

Gluteals (17)

**POSITION :** Standing, facing the HG60 in the direction of the lower pulley, place the strap on the ankle.

**EXERCISE :** With the leg stretched, pull the leg to the back. Return to the start position.

**MUSCLES WORKED :** Gluteals.

### TRADE WARRANTY

DECATHLON guarantees this product for parts and labor, under normal conditions of use, for 5 years for the structure and 2 years for wear parts and labor starting on the date of purchase, confirmed by the date on the sales ticket.

DECATHLON'S obligation in compliance with this warranty is limited to the product's replacement or repair, at DECATHLON'S convenience.

All the products for which the warranty is applicable, shall be accepted by DECATHLON in one of its authorized service centers, sent postage paid together with the proof of the purchase.

This warranty cannot be applied in the following cases:

- Damage caused during transport
- Misuse or abnormal use
- Repairs done by people not authorized by DECATHLON
- The commercial use of the product concerned

This trade warranty does not exclude the legal guarantee(s) applicable according to countries and / or provinces.