



PLACE SERIAL NUMBER LABEL HERE



# FACTORY CONTACT INFORMATION



BAY TEK GAMES INC.  
Pulaski Industrial Park  
1077 East. Glenbrook Drive  
Pulaski, WI 54162 USA

## JOIN OUR SERVICE FIRST NETWORK!

This free service is intended to keep you up to date on the latest game information, early notification of parts specials, pertinent technical bulletins, updates on retro fit parts, software upgrades, and much more.

Log on to: [www.baytekgames.com/parts](http://www.baytekgames.com/parts)  
then click on the Parts N' Service tab, or scan the QR code below with your Smartphone to jump straight to this game's parts page!

Scan here!



### SALES

P: 920.822.3951

F: 920.822.8936

E: [sales@baytekgames.com](mailto:sales@baytekgames.com)

### PARTS

P: 920.822.3951 X 1101

F: 920.822.1496

E: [parts@baytekgames.com](mailto:parts@baytekgames.com)

### SERVICE

P: 920.822.3951 X 1102

F: 920.822.1496

E: [service@baytekgames.com](mailto:service@baytekgames.com)

MON - FRI  
8 AM - 5 PM C.S.T.

All games are proudly manufactured at our factory in Pulaski, Wisconsin, USA

# TABLE OF CONTENTS

FACTORY CONTACT INFORMATION . . . . .	2
WELCOME TO: HopStar . . . . .	4
HOW TO PLAY . . . . .	5
SPECIFICATIONS . . . . .	6
SAFETY PRECAUTIONS . . . . .	6
SET UP GUIDE . . . . .	7-9
MAIN MENU FUNCTIONS . . . . .	10-14
GAME SETTINGS . . . . .	11
PAY IN/OUT . . . . .	12
TICKET PATTERNS . . . . .	13
STATISTICS . . . . .	14
DIAGNOSTICS . . . . .	14
MAINBOARD LAYOUT . . . . .	15
MAINBOARD PINOUT . . . . .	16
WIRING DIAGRAMS . . . . .	17-20
TROUBLESHOOTING GUIDE . . . . .	21-26
HOP PAD DIAGNOSTICS . . . . .	27-29
HOW TO: ACCESS MONITOR . . . . .	30
POWER SUPPLY DIAGNOSTICS . . . . .	31
BILL ACCEPTOR DIAGNOSTICS . . . . .	32
CARD SWIPE INSTRUCTIONS . . . . .	33
PARTS LIST . . . . .	34
PARTS PICTURES . . . . .	35-36
DECAL ID/ PLACEMENT CHART . . . . .	37
MAINTENANCE LOG . . . . .	38
TECHNICAL SUPPORT . . . . .	39
WARRANTY . . . . .	40

# WELCOME TO: HOPSTAR

## Congratulations on your HopStar purchase!

Bay Tek's original active game HopStar will get your game room hopping! Encourage active play and competition with the fast-paced Hopscotch-like gameplay of HopStar!

Please take a moment to read through this manual and be sure to contact our factory if you have any questions, or would like some more information.

Thank you for your purchase! Your business is important to us and we hope you enjoy this game as much as we do!

*Your Friends at Bay Tek Games*



## GAME INSPECTION

Inspect the game for any damaged, loose, or missing parts.

If damage is found, please contact your freight carrier first.

Then, contact Bay Tek Games' Service Department at 920.822.3951 or e-mail them at [service@baytekgames.com](mailto:service@baytekgames.com) for further assistance.

## HOW TO PLAY

Hop your way through the hopscotch course, using one or two feet according to the screen.

Hop on as many squares as you can before time runs out.

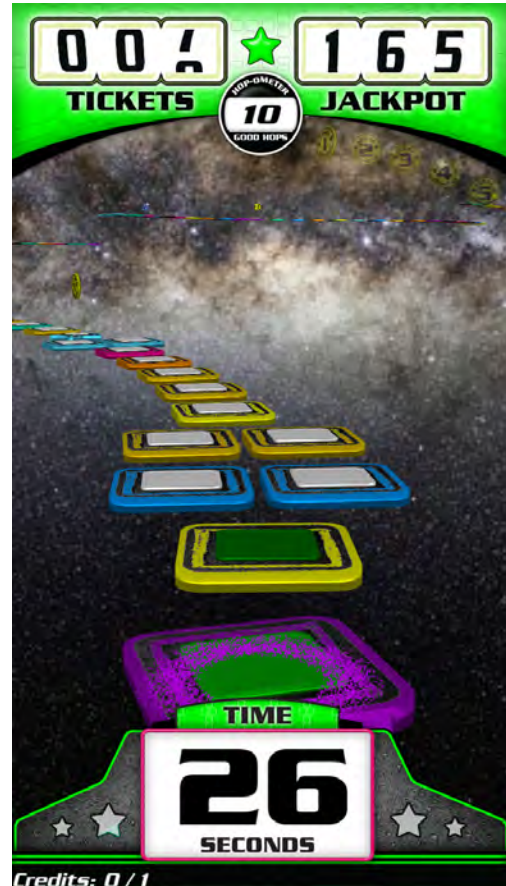

If you get far enough, you could score extra time or bonus tickets!



Get tickets at the end of your game for each square you hopped on.















# GAME SPECIFICATIONS

WEIGHT	
NET WEIGHT	350 lbs
SHIP WEIGHT	400 lbs
DIMENSIONS	
WIDTH	50.5"
DEPTH	75"
HEIGHT	90.5"
OPERATING TEMPERATURE	
FAHRENHEIT	80-100
CELSIUS	26.7-37.8

POWER REQUIREMENTS			
INPUT VOLTAGE RANGE	100 to 120 VAC	/	220 to 240 VAC
INPUT FREQUENCY RANGE	50 HZ	/	60 HZ

MAX START UP CURRENT	OPERATING CURRENT
2.2 AMPS @ 115 VAC	2.6 AMPS @ 115 VAC
1.1 AMPS @ 230 VAC	1.3 AMPS @ 230 VAC

# SAFETY PRECAUTIONS

 <b>NOTICE</b> 
Modifications to the mechanical, electrical and structural components of this game may void its compliance certifications.
 <b>DANGER</b> 
DO NOT perform repairs or maintenance on this game with the power ON. Unplug the unit from the wall outlet or shut off the power strip located inside the cabinet.
 <b>WARNING</b> 
Use of flammable substances can cause sever burns or serious injury. Always use NON-FLAMMABLE solvents for cleaning. DO NOT use gasoline kerosene or thinners.
 <b>CAUTION</b> 
Lifting heavy objects can cause back, neck or other injuries. Be sure adequate lifting and moving devices are available when unloading, unpacking and moving this game.
 <b>ATTENTION</b> 
Be sure the electrical power matches the game requirements. See the serial number located on the back of the game cabinet. Always plug into a grounded circuit. If the supply cord is damaged, it must be replaced by an approved cord or assembly provided by the manufacturer.
 <b>IN CASE OF EMERGENCY</b> 
UNPLUG THE POWER CORD. The power cord must be accessible at all times in case of an emergency.

# SET UP GUIDE

## HOP PAD INSTALLATION

Place the monitor cabinet of the game near its final location.



Remove the black plastic sheet from the base and set aside. **KEEP ALL SCREWS.** Extra screws are located in the cashbox.

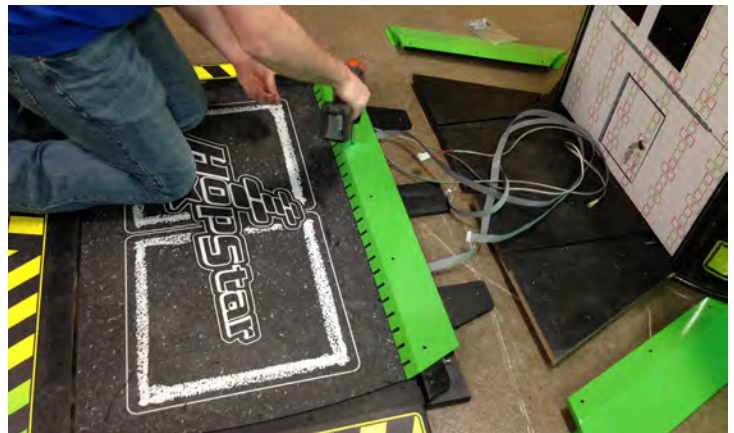

Slide the tabs on the hop pad into the notches of the cabinet base and feed the cables up into the cabinet; a **ribbon cable**, **power cable**, and **2 ground straps** into the **LEFT** side hole and a single **ribbon cable** in the **RIGHT** side hole.

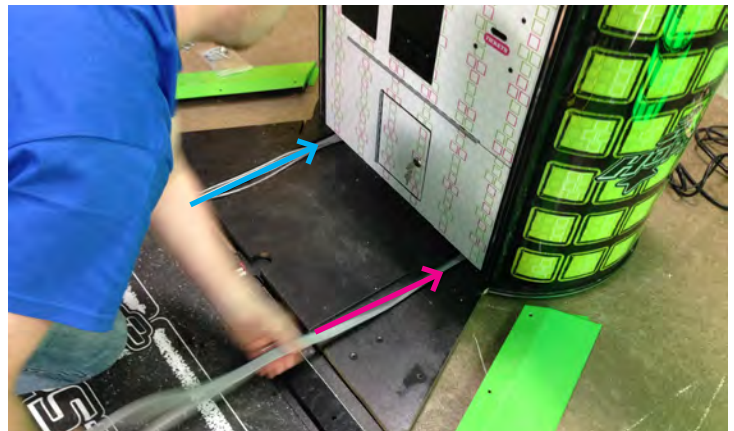

Replace the black plastic sheet.



## SET UP GUIDE

Place the green side metal pieces on the edges of the middle platform and secure with 3 tapered screws each, shown below.



Add the slotted green metal piece at the edge of the pad and secure with 5 tapered screws. Also secure the black plastic sheet with 4 panhead screws, shown below.



Open the front door of the cabinet and fish out the cables fed through earlier. Plug the ribbon cables into the AUX board as shown, LEFT on the bottom and RIGHT on the top (board is labeled for reference).

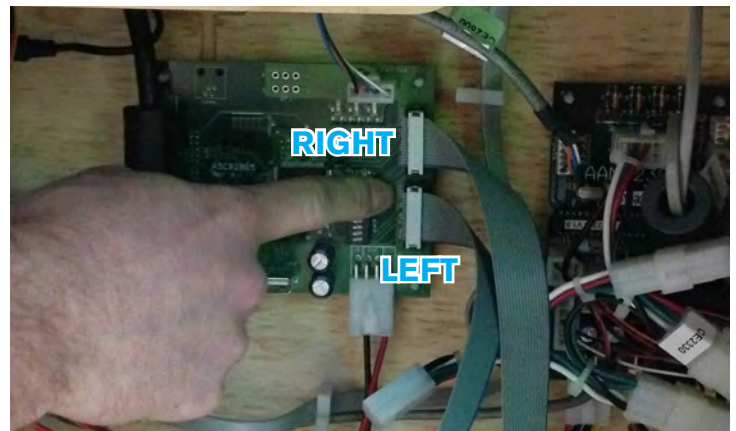

Plug the power cable (from the left side) into the power supply (yellow and black wires).

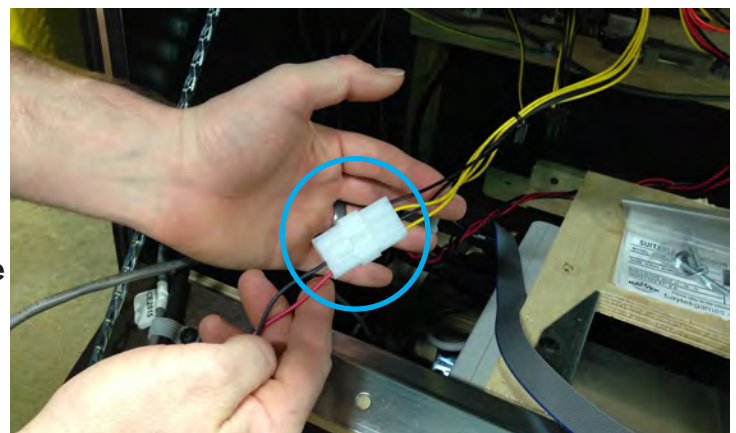

**Make sure all cables are securely clipped into the wire saddles to avoid getting pinched in the door and obstructing the cashbox.**



## SET UP GUIDE

Open the back door of the cabinet and locate the terminals on the ground cables near the line filter box; plug in the ground cables from the left side of the hop pad.

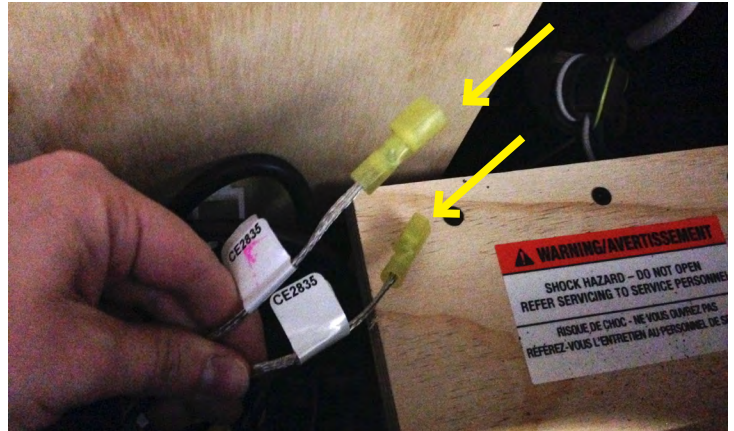

### MARQUEE INSTALLATION

Plug in the speaker and LED lights to the housings near the top of the cabinet.

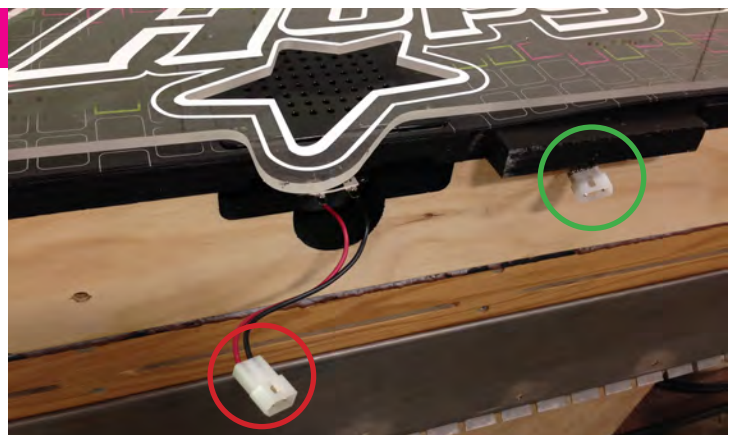

Prop the marquee up into position and secure with included hex bolts and washers.



Plug the game into a standard electrical outlet and turn the power strip to the ON position.



# MAIN MENU FUNCTIONS

Press and hold the MENU button inside the front door of the cabinet to open the main menu.

Scroll through the selections with the MENU button, and adjust settings with the SELECT button.

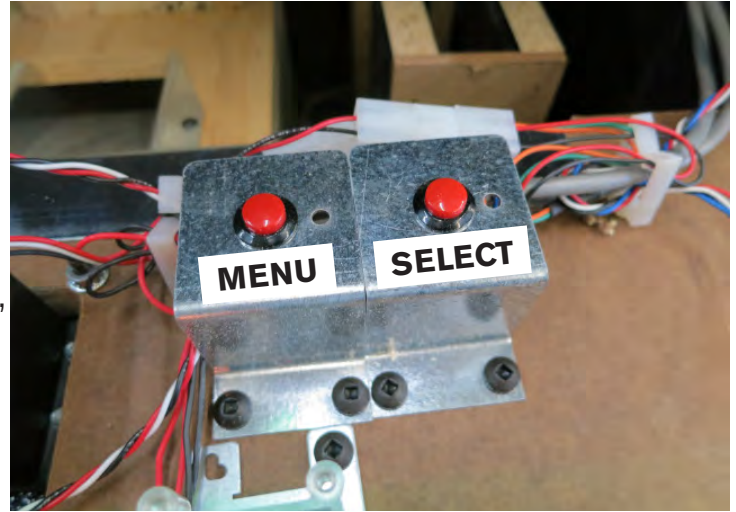

## MAIN MENU

**Game Volume: 80**

**Attract Volume: 40**

**Clear Credits & Tix: : 3x's**

**Game Settings Menu >>**

**Pay In/Out Menu >>**

**Statistics Menu >>**

**Diagnostics Menu >>**

**Exit**

MAIN MENU				
<b>Game Volume</b>	0 (off)	to	100 (max)	80
<b>Attract Volume</b>	0 (off)	to	100 (max)	40
<b>Clear Credits &amp; Tickets</b>	press select 3 times to clear credits and tickets owed			

# GAME SETTINGS MENU

## GAME SETTINGS MENU

**Squares in Level: 16**

**Red X's in Game: 10**

**Game Time: 20 sec**

**Training Mode: Disabled**

**Back**

SETTINGS MENU					
<b>Squares in Level</b>	10	TO	25	ADJUSTABLE IN INCREMENTS OF 1	16: DEFAULT
<b>Red Xs in Game</b>	0	TO	25	ADJUSTABLE IN INCREMENTS OF 1	10: DEFAULT
<b>Game Time*</b>	10 SEC	TO	60 SEC	ADJUSTABLE IN INCREMENTS OF 5	20: DEFAULT
<b>Training Mode</b>	ENABLED			DISABLED	

\*All Game Time settings include 2 bonus clocks of 5 seconds each, potentially adding up to 10 seconds of play.

# PAY IN/OUT MENU

## PAY IN/OUT MENU

**Credits: 4**

**Card Reader: Disabled**

**Divide By 2: Disabled**

**Fixed Ticket Payout: Disabled**

**Tickets Per Square**

**Tickets: 1**

**Squares: 2**

**Level Bonus: 5 tix**

**Jackpot: 100 tix**

**Jackpot Incr: 1 tix**

**Jackpot Cap: 999 tix**

PAYOUT MENU													
CREDITS PER PLAY	0	1	2	3	4	5	6	7	8	9	10		
CARD READER	ENABLED					DISABLED							
DIVIDE BY 2 (DOUBLE TICKET)	ENABLED					DISABLED							
FIXED TICKET PAYOUT	0 (off)	1	2	3	4	5	6	7	8	9	10		
TICKETS PER SQUARE													
TICKETS	0	1	2	3	4	5	6	7	8	9	10		
# OF SQUARES	1	2	3	4	5	6	7	8	9	10			
LEVEL BONUS	0 (OFF)	TO	20	IN INCREMENTS OF 1					5: DEFAULT				
JACKPOT	25	TO	999	IN INCREMENTS OF 25					100: DEFAULT				
PROGRESSIVE INC.	0 (OFF)	TO	25	IN INCREMENTS OF 1					1: DEFAULT				
PROGRESSIVE CAP	0	TO	999	IN INCREMENTS OF 25					999: DEFAULT				

## TICKET PATTERNS

AVERAGE TICKETS PER GAME	TICKETS	*SQUARE	**LEVEL BONUS	JACKPOT	JACKPOT INCREMENT	JACKPOT CAP
<b>3-4</b>	1	10	0	25	DISABLED	999
<b>6-9</b>	1	10	1	50	1	999
<b>10-13</b>	1	8	2	50	1	999
<b>14-20</b>	1	5	3	100	1	999
<b>24-28</b>	1	3	4	100	1	999
<b>30-36</b>	1	2	5	100	1	999
<b>48-54</b>	2	3	5	500	1	999
<b>60-66</b>	2	3	10	500	1	999

\* Major adjustments to the ticket payout should be made by adjusting the number of squares in the “tickets per squares” options.

A higher value of squares lowers the payout, while a lower number of squares increases the payout.

\*\* Fine-tuning the payout can be accomplished by adjusting the Level Bonus; up for higher payout, down for lower payout.

## STATISTICS MENU

### **STATISTICS MENU**

**Total Games: 25**

**Total Tickets: 3225**

**Jackpot Tickets: 1522**

**Average Tickets/Game: 129**

**Jackpot Winners: 16**

**Reset Stats : 3x's**

**Back**

## DIAGNOSTICS MENU

### **DIAGNOSTICS MENU**

**Menu Button: Up**

**Select Button: Up**

**\* Hop: No Feet**

**Test Ticket Dispense**

**Change Monitor Light**

**Default Settings : 3x's**

**Back**

\* "Hop" refers to the state of the hop pad; No Feet is displayed when nothing is on the pad.

Both Feet will display if two objects are on the pad.

Left Foot, Middle Foot or Right Foot will display if there is one object detected.

# AAMB2300 BOARD LAYOUT

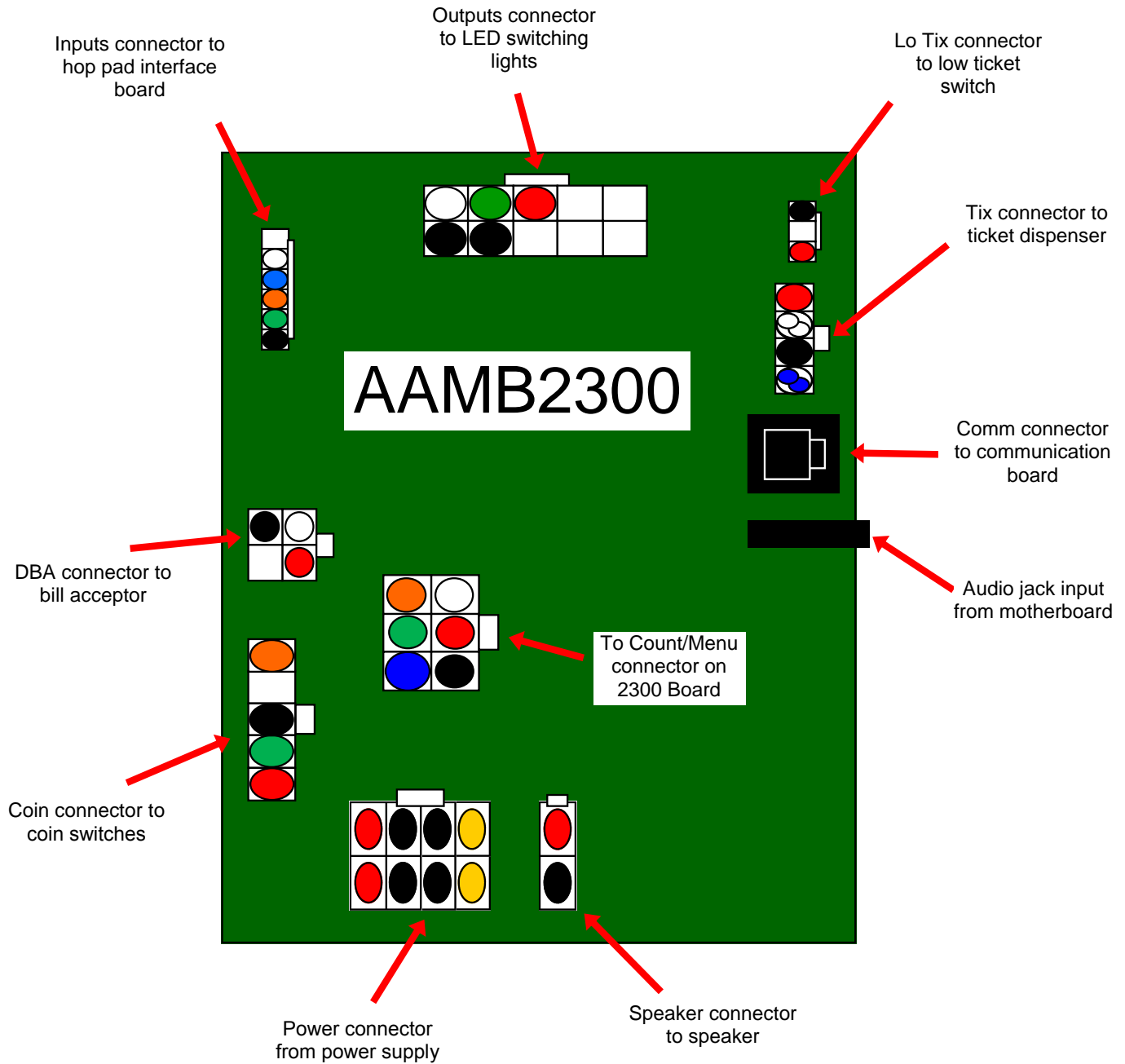

# AAMB2300 BOARD PINOUT

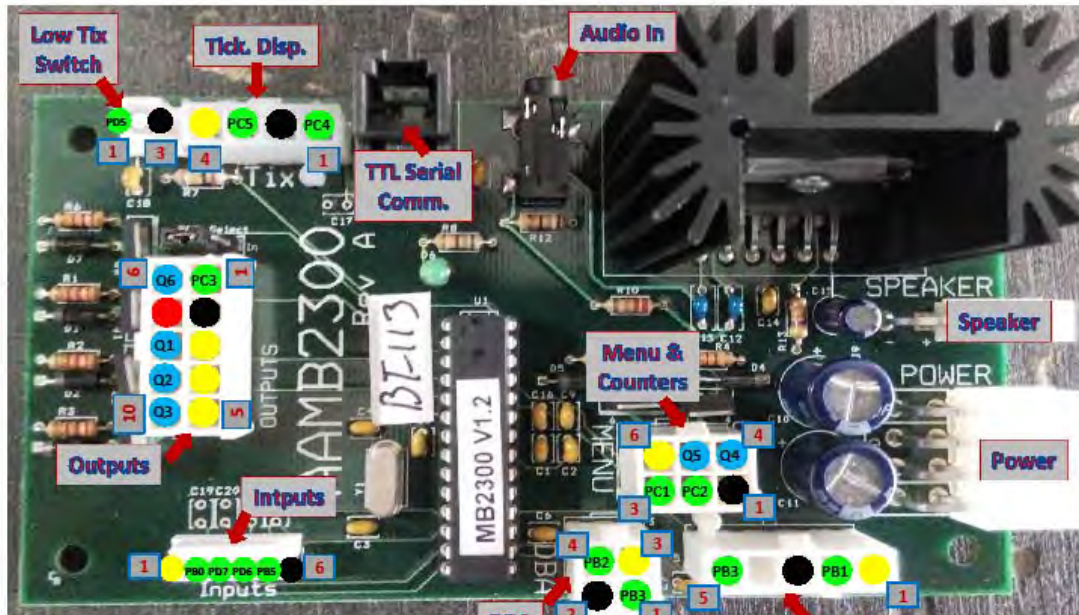

- GROUND
- +5VDC
- +12VDC
- LOWSIDE OUTPUT
- TTL LOGIC



**POWER**



**SPEAKER**

\*\* PC3 and Q6 use the same I/O line. If using PC3 as an input select "IN" on the jumper above the "Outputs" header. If using PC3 to control FET Q6, set the jumper to "Out"

## HOPSTAR AAMB2300 I/O ALLOCATION

POWER HEADER		
PIN TYPE	PURPOSE	PIN#
+12V		1
GND		2
GND		3
+5V		4
+12V		5
GND		6
GND		7
+5V		8

MENU BUTTONS, MECH. COUNTERS		
PIN TYPE	PURPOSE	PIN #
GND		1
PC2	MENU BUTTON 1	2
PC1	MENU BUTTON 2	3
Q4	GAME COUNTER	4
Q5	TICKETS COUNTER	5
+12V		6

TICKET DISPENSER		
PIN TYPE	PURPOSE	PIN #
PC4	TICKET NOTCH	1
GND		2
PC5	TICKET ENABLE	3
+12V		4

DBA		
PIN TYPE	PURPOSE	PIN#
PB3	CREDIT INHIBIT/LOCKOUT	1
GND		2
+12V		3
PB2	DBA SIGNAL IN	4

COIN		
PIN TYPE	PURPOSE	PIN #
+12V		1
PB1	COIN SIGNAL IN	2
GND		3
-		4
PB3	CREDIT INHIBIT/LOCKOUT	5

INPUTS		
PIN TYPE	PURPOSE	PIN #
+12V		1
PB0	Hop Pad Input 1	2
PD7	Hop Pad Input 2	3
PD6	Hop Pad Input 3	4
PB5		5
GND		6

OUTPUTS		
PIN TYPE	PURPOSE	PIN #
PC3**		1
GND		2
+12V		3
+12V		4
+12V		5
Q6**		6
+5V		7
Q1	RED Lighting	8
Q2	GREEN Lighting	9
Q3	BLUE Lighting	10

\*\* PC3 and Q6 use the same I/O line. If using PC3 as an input select "IN" on the jumper above the "Outputs" header. If using PC3 to control FET Q6, set the jumper to "Out"



# WIRING DIAGRAMS

## MENU BUTTONS, COUNTERS, COIN INPUTS & TICKET DISPENSERS

To Bill Acceptor (Part # A5AC9091)  
Optional – Not included with game.  
A5PL4200 (Mounting Plate) needed to  
install DBA.

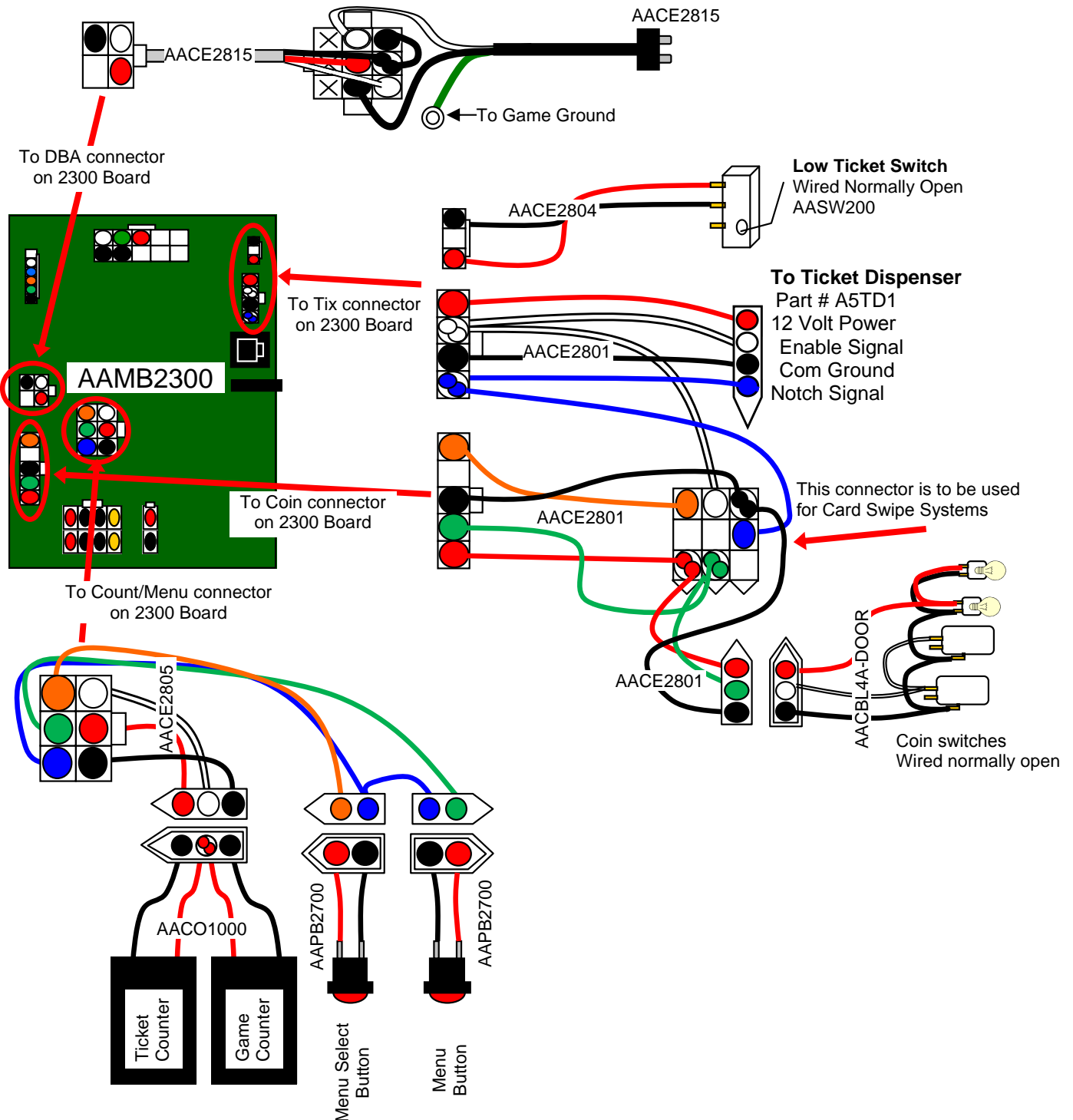

# WIRING DIAGRAMS

## COMMUNICATION, SPEAKER & LED LIGHTING

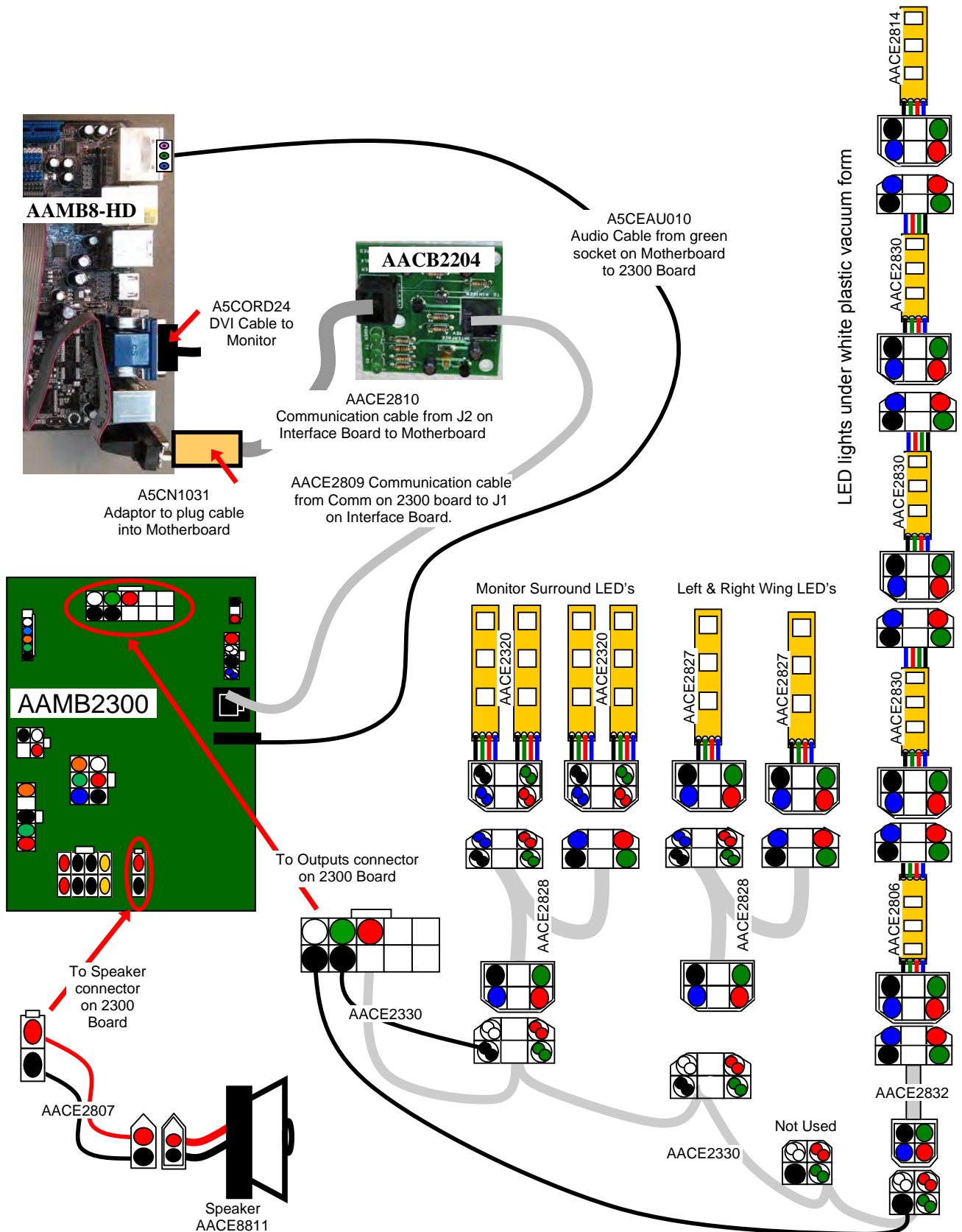

# WIRING DIAGRAMS

## POWER IN & 12 VOLT SUPPLY

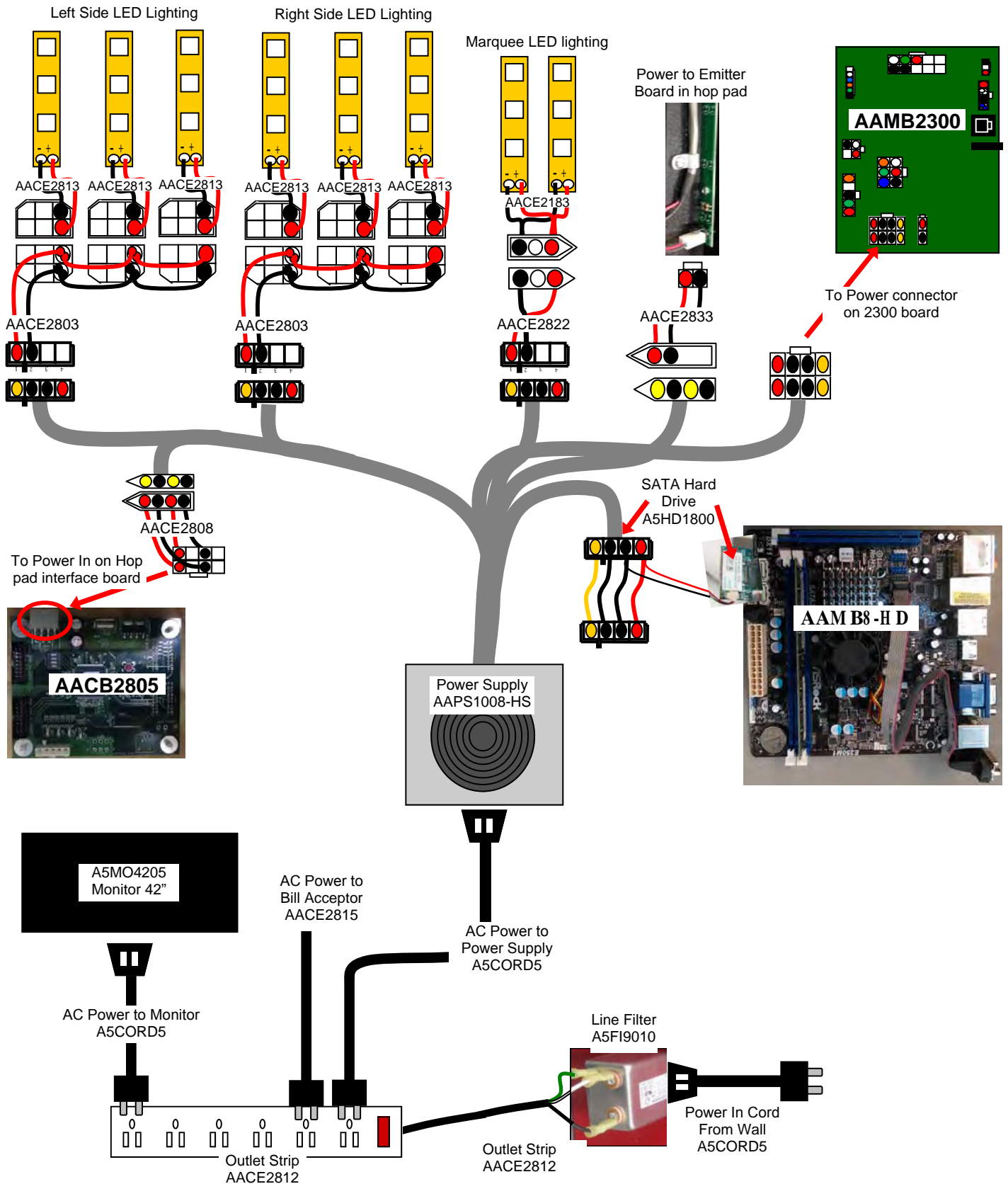

# WIRING DIAGRAMS

## HOP PAD

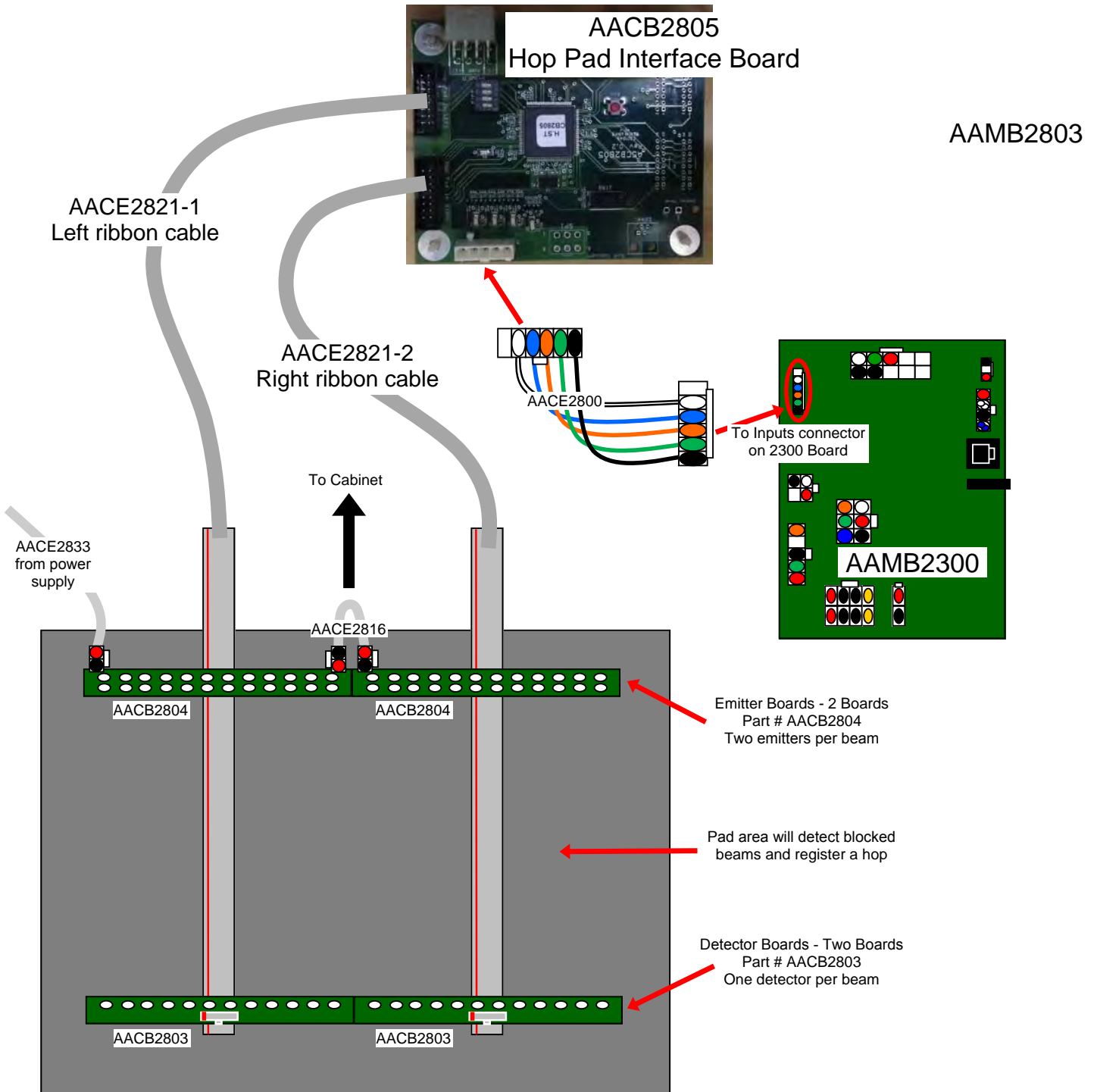

The hop pad is a set of emitters on edge closest to cabinet, and a set of detectors on the edge furthest away from cabinet. Pad area will detect blocked beams and register a hop.



# TROUBLESHOOTING GUIDE

## Troubleshooting Strategy



Use common sense and a systematic method of troubleshooting to determine the exact problem, probable cause and remedy. Use the process of elimination to find the faulty component. Always check for the simple and obvious causes first such as unplugged, loose or broken wires and bad sensors, bent, pinched, stuck or jammed components.

Problem	Probable Cause	Remedy
<p><b>No power to the game. No lights on at all.</b></p>	<p>Unplugged. Circuit breaker tripped. Power strip faulty. Faulty cable/power supply.</p>	<p>Check wall outlet. Reset power strip breaker switch or building circuit breaker. Change plug position, replace if needed. See Power Supply diagnostic section</p>
<p><b>Bill Acceptor powers on. But everything else off. (Power Supply not ON)</b></p>	<p>Power supply unplugged. Rocker Switch and voltage switch. Power supply shutting down because of 12 V overload. Faulty power supply.</p>	<p>Insure unit is plugged into power strip. Make sure rocker switch is set ON. (-) and switch at 100V or 230V  See power supply diagnostics to isolate bad component. A bad motor or 12 volt short would cause this. See Power Supply Diagnostic section</p>
<p><b>Dollar Bill Acceptor not functioning.</b></p> <p>Ensure Bill Acceptor is set to "Always Enable"</p>	<p>Check for power to Bill Acceptor. Dirt or debris in acceptor slot. Pinched, broken, or disconnected wiring. Bill acceptor problem.</p>	<p>Acceptor should cycle stacker at game power up. If not, check cable connections. Refer to "How to Clean Bill Acceptor" Or clean with bill reader cleaning card. (A5CC9000) Check wiring from bill acceptor to 2300 Board. (AAE2815) Repair or replace wiring harness. Check DBA connector on 2300 Board Make sure wires are secure in connectors. Refer to troubleshooting section of dollar bill acceptor manual included with this game or the diagnostics label of the back of the unit.</p>
<p><b>Game not coining up.</b></p>	<p>Ensure game makes "doing" sound when coin switch is triggered. Verify communication between motherboard and 2300 board. Game set to large amount of credits per game.</p>	<p>Check coin switches—both should be wired normally open. If one switch is "closed" the other will not work either. Check wiring to 2300 board. (AACBL4A-DOOR, AACE2801) Refer to "Comm Error" troubleshooting section.  Check Pay In/Out Menu. Ensure Credits per Game is set. Default = 4</p>

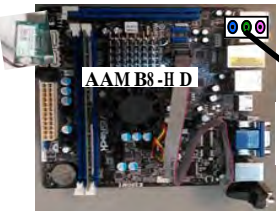
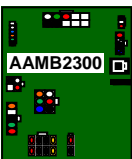
# TROUBLESHOOTING GUIDE

Problem	Probable Cause	Remedy
<p><b>Cabinet Lighting does not work.</b></p> <p>There are 2 different types of cabinet lighting</p>	<p><b>12 Volt White LED's</b></p> <p>Faulty cable. Disconnected, loose or broken wires. Individual LED strip out</p>	<p>These LED's receive power directly from power supply</p> <p>Refer to "Power In &amp; 12 Volt Wiring Diagram"</p> <p>Identify LED strip, check soldered wires, replace if needed.</p>
<p><b>12 Volt White LED's &amp; Colored LED's that change color</b></p> <p>Enter Diagnostic menu and select "Change Monitor Lights"</p>	<p><b>Colored LED's</b></p> <p>Faulty cable. Disconnected, loose or broken wires. Individual LED strip out</p> <p>Entire section of LED's do not work</p> <p>Specific Colors do not light on all LED strips</p>	<p>These LED's receive power from 2300 Board</p> <p>Refer to "Communication, Speaker &amp; LED Wiring Diagram"</p> <p>Identify LED strip, check soldered wires, replace if needed.</p> <p>Check main jumper cable (AACE2330) Look for broken wire</p> <p>2300 Board may be faulty. Check connection "Outputs" on main 2300 board. Replace if needed.</p>
<p><b>Colored LED's not functioning properly</b></p> <p>Enter Diagnostic menu and select "Change Monitor Lights"</p>	<p>Faulty cable. Disconnected, loose or broken wires. Individual LED strip out</p> <p>Entire section of LED's do not work</p> <p>Specific Colors do not light on all LED strips</p>	<p><b>These LED's receive power from 2300 Board</b></p> <p>Refer to "Communication, Speaker &amp; LED Wiring Diagram"</p> <p>Identify LED strip, check soldered wires, replace if needed.</p> <p>Check main jumper cable (AACE2330) Look for broken wire</p> <p>2300 Board may be faulty. Check connection "Outputs" on main 2300 board. Replace if needed.</p>
<p><b>No Sound</b></p> <p>Motherboard creates sound, 2300 board amplifies it.</p> <div style="display: flex; align-items: center;">  <div style="margin-left: 10px;">  <p style="font-size: small;">A5CEAU010 Audio Jack from Motherboard to 2300 Board</p> </div> </div>	<p>Volume set to zero in menu.</p> <p>Disconnected, loose or broken wires.</p> <p style="text-align: center;">Determine if 2300 board is ok</p> <p>Faulty speaker.</p>	<p>Enter Main Menu and verify: Game Volume &amp; Attract Volume are not zero</p> <p>Check connections and reseat audio cable from motherboard to 2300 board. Cables # AACE8811, AACE2807, and A5CEAU010.</p> <p>Unplug audio jack cable (A5CEAU010) from motherboard, plug into MP3 player and see if music is amplified and comes out of speaker. If Yes - then motherboard is faulty. If No - then 2300 board may be faulty.</p> <p>Replace speaker. AACE8811</p>

# TROUBLESHOOTING GUIDE

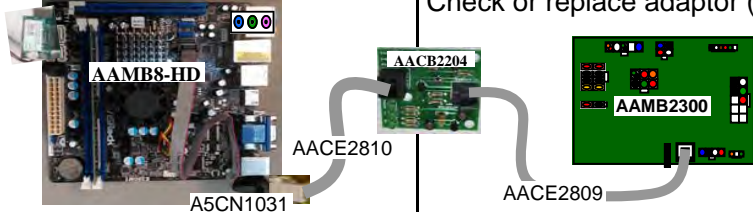
Problem	Probable Cause	Remedy
<b>Tickets do not dispense or Wrong amount dispensed.</b>  Check for the correct amount of tickets showing on Monitor	Tickets on monitor does <b>not</b> match tickets coming out of game.	Opto Sensor on ticket dispenser dirty. Faulty ticket dispenser. Notch on tickets cut too shallow. Faulty cable. Disconnected, loose or broken wires. Faulty 2300 Board.
	Tickets on monitor does match tickets coming out of game.	Settings in Menu are incorrect.
<b>Low Tickets message on monitor</b>  The number of tickets left to dispense will also show	Tickets are empty in ticket tray Faulty cable. Disconnected, loose or broken wires. Faulty low ticket switch. Faulty MiniGen Board	Load tickets into tray. Ensure tickets hold down micro switch wire. Switch is part # AASW200 Check connectors from low ticket switches to 2300 board. Check for continuity. (AACE2804) Inspect switch and replace if needed. (AASW200) Replace 2300 Board. (AAMB2300)
<b>No Communication between boards.</b>  <b>Game does not coin up</b>    Game <b>has</b> audio track "doing" sound from speakers when coin switch triggered.	Check green LED's on Serial Interface board. "Power" solid ON "TX" & "RX" blinking very fast, 	
	<b>If "Power" is not solid ON</b>  Ensure AACE2809 cable is plugged into 2300 board. (Comm) 	<b>If "TX" &amp; "RX" are not blinking very fast</b> Communication to Motherboard faulty.  Check AACE2810 to motherboard. Check or replace adaptor (A5CN1031)
	<b>If "TX" is solid ON</b> Motherboard is faulty. Replace AAMB8-HD	<b>If "RX" is solid ON</b> 2300 Board is faulty. Replace AAMB2300

# TROUBLESHOOTING GUIDE

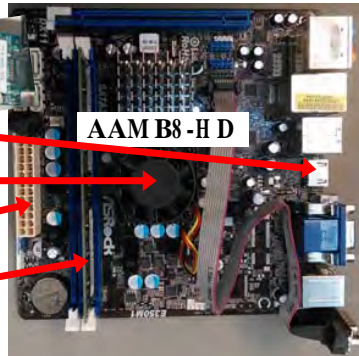
Problem	Probable Cause	Remedy
<p><b>Game Meter does not work.</b></p> <p>Game meter will click at end of game.</p>	<p>Verify meter does not click at end of game</p> <p>Disconnected, loose or broken wires.</p> <p>Faulty counters.</p>	<p>This is done because Hop Star will not start a game until hop pad registers jumps.</p> <p>Check connections and reseat Count/Menu on 2300 board. Cables # AACE2805 and AACO1000</p> <p>Replace counters. AACO1000</p>
<p><b>Ticket Meter does not work.</b></p> <p>Ticket meter will click as tickets come out of game and notch is "seen" by dispenser.</p>	<p>Ensure correct number of tickets are being dispensed.</p> <p>Disconnected, loose or broken wires.</p> <p>Faulty counters.</p>	<p>Check ticket values, refer to Tickets not Dispensing troubleshooting section.</p> <p>Check connections and reseat Count/Menu on 2300 board. Cables # AACE2805 and AACO1000</p> <p>Replace counters. AACO1000</p>
<p><b>Menu Buttons do not work.</b></p>	<p>Disconnected, loose or broken wires.</p> <p>Faulty button.</p> <p>Faulty communication between motherboard and Minigen</p> <p>Faulty AAMB2300 board.</p>	<p>Check connections from button to 2300 board. Cables # AAPB2700 and AACE2805</p> <p>Test button and replace. (AAPB2700)</p> <p>Refer to "No Communication between boards" troubleshooting section.</p> <p>Replace AAMB2300 board.</p>
<p><b>Hop pad does not work properly.</b></p>	<p>The pad is constantly monitoring itself will recalibrate throughout game play, and at power ON.</p>	<p>Turn off game power, wait 10 seconds, and power game back on. See if problem persists.</p> <p>Refer to "Hop pad diagnostic" section.</p>
<p><b>Monitor shows "No Signal" then black.</b></p> <p style="color: red;">Re-Boot game to see if problem still exists.</p> <p>Power game down, wait 10 seconds, then power game ON to reset.</p> <p>Motherboard/power supply is not working.</p>	<p>Faulty power supply - Check for 12 Volts and blinking green LED on SATA Drive</p> <p>Monitor HDMI cable unplugged.</p> <p>Fan turning.</p> <p>Large power connector unplugged on motherboard.</p> <p>Faulty or loose RAM</p>	<div style="text-align: center;">  <p style="text-align: center; margin-top: 10px;">Refer to Monitor/Motherboard Power Supply Diagnostics for further diagnostic information.</p> </div>



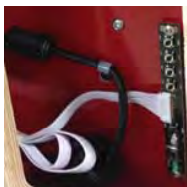
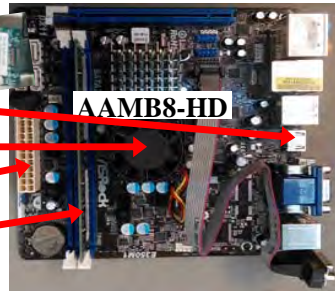

# TROUBLESHOOTING GUIDE

Problem	Probable Cause	Remedy
<b>Monitor not working.</b>  Power down, wait 10 seconds and power up again.	Monitor says "NO SIGNAL" for 5 seconds after power - up.  Then dark.	Faulty power supply - Check for 12 Volts and blinking green LED on SATA Drive Monitor HDMI cable unplugged. Fan turning. Large power connector unplugged on motherboard. Faulty or loose RAM Refer to Monitor/Motherboard Power Supply Diagnostics for further diagnostic information.
	Monitor has nothing at all on power up.	Power cable unplugged from monitor.  Faulty monitor.
 Error on screen at power up.  Re-Boot game to see if problem still exists.  Power game down, wait 10 seconds, then power game ON to reset.	Monitor shows ASROCK SETUP UTILITY"  Display shows "Sleep Mode" on screen.  Display shows "Kernel panic – unable to mount root" on screen.  Display shows anything other than HopStar software on screen.	SATA Drive unplugged from board or faulty Refer to "Monitor shows ASROCK SETUP UTILITY" section.  Power Supply or Motherboard not Communicating correctly with monitor. Refer to "Monitor shows Sleep Mode on screen" section.  Faulty or loose RAM Refer to "Monitor shows Kernel panic – unable to mount root" section.  Motherboard is not loading or running program. Refer to "Monitor shows anything else other than HopStar program on screen" section.
<b>Monitor shows nothing at all on power on.</b>  Open rear access door.	Power cable unplugged from monitor. Power strip faulty  Faulty power cable for monitor  Re-Boot game and check for any errors on monitor. Power game down, wait 10 seconds, then power game ON to reset.  Faulty monitor.	Ensure power is plugged into bottom of monitor, down to power strip. Change plug position, replace if needed (AACE2812) Check A5CORD5 to ensure 110 volts to Monitor. If error shows on monitor, refer to suggestions above.  Replace monitor. (A5MO4205)



# TROUBLESHOOTING GUIDE

Troubleshooting Chart		
Problem	Probable Cause	Remedy
<p><b>Monitor shows “ASROCK SETUP UTILITY”</b></p> 		<p>Small clip-in hard drive is not being seen by computer.</p> <p>Push on spring clip and gently remove from motherboard. Re-install and power on game.</p> <p>Try in different SATA slot on motherboard.</p> <p>Replace hard drive. (A5HD1800)</p> <p>Replace motherboard. (AAMB8-HD)</p>
<p><b>Monitor shows “Sleep Mode” on screen.</b></p> <p>Re-Boot game to see if problem still exists.</p> <p>Power game down, wait 10 seconds, then power game ON to reset.</p>	<p>Power Supply or Motherboard not communicating correctly with monitor.</p>	<p>Check power supply voltage.</p> <p>Replace power supply. (AAPS1008-HS)</p> <p>Ensure power supply connection is secure to motherboard.</p> <p>Refer to Monitor/Motherboard Power Supply Diagnostics</p> <p>Replace motherboard. (AAMB8-HD)</p>
<p><b>Monitor shows “Kernel panic- unable to mount root” on screen.</b></p>	<p>Faulty or loose RAM</p>	<p>Separate metal tabs on sides of RAM, it will flip up to remove.</p> <p>Re-install and Re-Boot game to see if problem still exists.</p> <p>Power game down, wait 10 seconds, then power game ON to reset.</p> <p>Replace motherboard. (AAMB8-HD)</p>
<p><b>Monitor shows anything else other than HopStar program on screen.</b></p> <p>Re-Boot game to see if problem still exists.</p> <p>Power game down, wait 10 seconds, then power game ON to reset.</p>	<p>Motherboard has trouble loading or running program</p>	<p>Large power connector unplugged on Motherboard</p> <p>Faulty or loose RAM</p> <p>Faulty motherboard - Replace faulty board. (AAMB8-HD)</p>
<p><b>Monitor problems</b></p> <p>Blurry Monitor</p> <p>Too bright, or dim.</p>	<p>Press the auto button to select Auto Adjustment.</p> <p>This may take a few seconds.</p> <p>Verify that the screen looks good and Image is centered.</p>	

# HOP PAD DIAGNOSTICS

The foot detection consists of 2 infrared emitter boards close to cabinet and 2 detector boards on the far edge of the hop pad.

These boards create 24 beams of infrared light. The players feet interrupt these beams and the game interprets this as hops.  
The game is constantly reading these beams and re-calibrating the position of the player as they move across the pad

The game will detect 2 feet as a player normally is standing, then calibrate a center position where it will detect the single foot, and also calibrate a left and right foot position where it will expect the left and right hop.

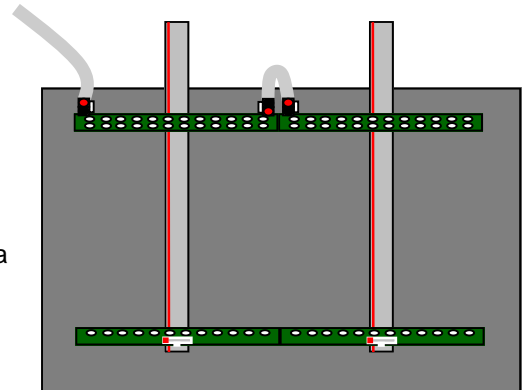

There are multiple diagnostic tools that will help in troubleshooting a faulty hop pad:

## DIAGNOSTICS MENU

- Menu Button: Up
- Select Button: Up
- Hop: No Feet
- Test Ticket Dispense
- Change Monitor Light
- Default Settings : 3x's
- Back

**A - Diagnostic Menu screen** will show the "Hop" position.  
Remember the pad will have to "see" a empty pad between hops.  
(As a player would be in the air)

Note: If a sensor beam is blocked - this will always show "No Feet" until obstruction is removed.

**B - LED indicators** on Hop Pad Interface Board

- Left LED is left foot
- Middle LED is middle position
- Right LED is right foot

Note: If a sensor beam is blocked - these LED's will not light until obstruction is removed.



**C - Green LED indicators** on the detector boards that will indicate if the infrared beam is blocked or sensor is faulty.

The green LED is normal ON.  
It will be OFF if path is blocked

If LED is dimly lit, the emitter board on the other end of the pad is blocked or faulty.

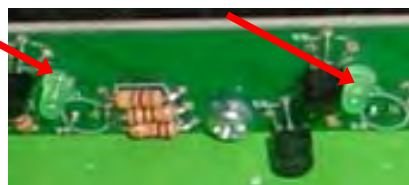

## HOP PAD DIAGNOSTICS, CONT.

### Step 1:

The most common issue is a dirty emitter or detector on the pad itself. If a beam is blocked the game will not register anything until the obstruction is removed.

**Solution:** Clean the clear plexi that is protecting the emitters and detectors on both sides of pad.



If after cleaning the emitter and detector clear plexi, the game still does not register a hop, then continue to Step 2.

### Step 2:

Remove the pad from the game and look at detector board LED indicators. How to:

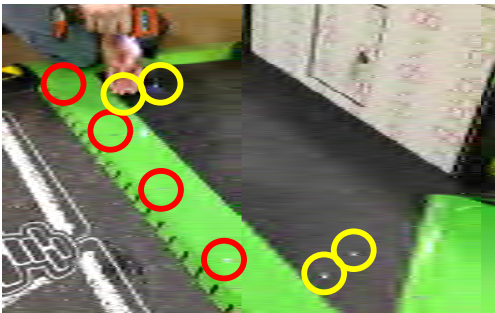

Remove the slotted green metal by removing 5 tapered screws. Also remove the 4 panhead screws holding the black plastic sheet.



Remove both green metal edgings by removing 3 tapered screws on each side.

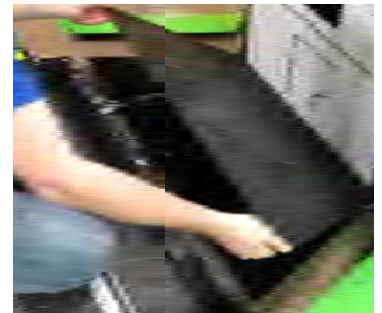

Lift up the black plastic and carefully slide out pad from main cabinet.

Tipping hop pad up, the detector boards can be seen under the clear plexi.

The green LED is normal ON. It will be OFF if path is blocked

If LED is dimly lit, the emitter board on the other end of the pad is blocked or faulty.



# HOP PAD DIAGNOSTICS, CONT.

## Hop Pad Interface Board Troubleshooting

**Orange flashing LED health indicator** on Pad Interface Board must be flashing.

If LED is not flashing:

- Check power in cable (# CE2808) from power supply to board.
- Replace Pad Interface Board (part # AACB2805)

## LED indicators on Hop Pad Interface Board

Left LED is left foot

Middle LED is middle position

Right LED is right foot

Note: If a sensor beam is blocked - these LED's will not light until obstruction is removed.

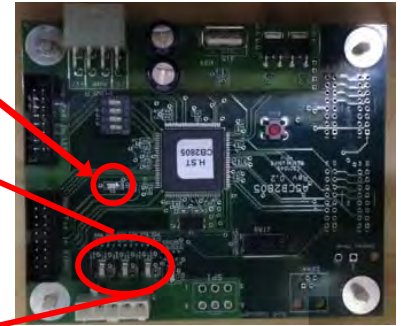

If LED's are functioning correctly, then Hop Pad and Interface Board is OK.

- Check AACE2800 cable to Microgen 2300 board.
- Replace Microgen 2300 board.

If LED's are not functioning, continue troubleshooting below, the pad sensors are not registering on this board. Problem may be emitters, detectors, cables or the Pad Interface Board itself.

## Emitter Board Troubleshooting

Emitter boards are under the front green metal closest to the cabinet.

There are 2 emitter boards, and each have 2 emitters per beam.

Verify the emitter boards have 12 volts on cable AACE2833 and also on the jumper cable between circuit boards AACE2816.

Replace emitter board if needed. Part # AACB2804



## Detector Board Troubleshooting

Tipping hop pad up, the detector boards can be seen under the clear plexi.

The green LED is normal ON.

It will be OFF if path is blocked

If LED is dimly lit, the emitter board on the other end of the pad is blocked or faulty.

There are 2 Detector boards, and each have 1 detector per beam.

The boards receive power by the ribbon cable part # AACE2821

Ensure these ribbon cables are flat and not pinched or scraped.

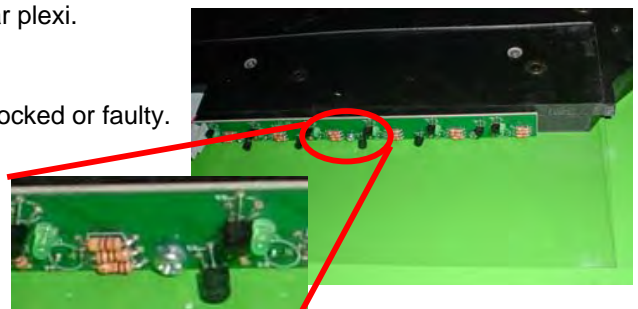

Ribbon cables plug into the Pad Interface Board—Ensure the left ribbon cable is plugged into top socket, and the right ribbon cable is plugged into the bottom socket.

Left

Right



Inspect ribbon cables and replace if needed. (Part # AACE2821)

Replace detector board if needed. (Part # AACB2803)

## HOW TO: REMOVE/ACCESS MONITOR

Remove power to game.

Remove screws around perimeter of monitor holding clear plexi and artwork on game.

Note: There is also one screw in the top center of marquee that must be removed.

Carefully remove plexi and artwork from cabinet.

On rear of cabinet, remove the 6 screws on an access panel.

Through this hole, the monitor power cord and SVGA cable can be unplugged.



Remove all silver screws surrounding monitor frame, and carefully remove monitor from cabinet.

Note: The frame will rest on a small lip to aid in supporting monitor.



# POWER SUPPLY DIAGNOSTICS

1.) Verify AC power to game. Check power strip in front door.

The rocker switch should be illuminated.



3.) Check connection to power supply.

4.) Ensure Power Supply switch is set to 115V (or 230V)  
(Some model power supplies may not have this)

5.) Ensure Power switch is on.

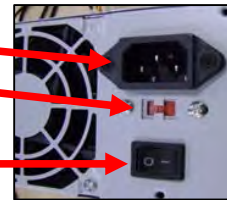

6.) Ensure fan is turning.

- If power supply fan is turning and there is no 12 Volt out, then replace power supply. (AAPS1008-HS)
- If power supply fan is not turning, then continue to "Verify Power to Motherboard"

## Verify Power to Motherboard

The motherboard will turn on power supply.

If your game has no 12 volts, it may be the motherboard not turning on.

In addition - there may be a 12 volt short somewhere else in cabinet that is not allowing the power supply to turn on.

## Minimize load on power supply and isolate short

Unplug all outputs from power supply except for motherboard.

This will have power supply, motherboard, and monitor left plugged in.

If power supply, motherboard, and monitor now turn on:

Plug in one component at a time to power supply to locate short.

If power supply still does not power on, then continue to steps 1,2, and 3.

**1** - Check single connection from power supply.

**2** - Verify these pins are covered by connector with a single capacitor.

If the connector is missing, continue to step 3 to jump the pins under this connector.

**3** - Motherboard "Jump Start"

As a last resort, you may start motherboard by quickly touching these 2 pins at the same time, then quickly release

Motherboard may turn ON and boot normally.

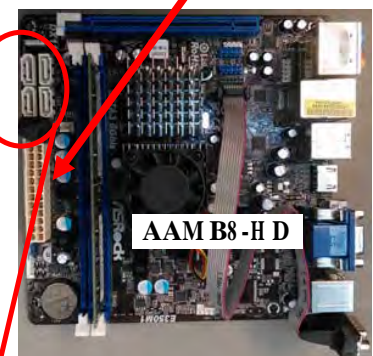
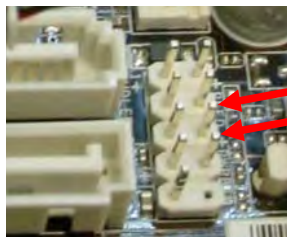

If power supply still does not power on, replace power supply (AAPS1008-HS) or motherboard. (AAMB8-HD)

# BILL ACCEPTOR DIAGNOSTICS

The HopStar game is Bill Acceptor ready. We recommend MEI AE-2451-U5E (Part # A5AC9091)  
If you would like to add one to the game, please make sure the mounting plate is present. (A5PL4200)

**Note:** There are many different models and brands of Bill Acceptors that are used on redemption games. Your Bill Acceptor may differ from the unit shown.

Determine if Bill Acceptor has power:

Turn game ON—The bill acceptor should make noise as stacker cycles and green lights on outside bezel should flash.

If NO power:

Use meter to measure 110 AC voltage at cable going into Bill Acceptor from power strip.

If power is OK:

Clean Bill Acceptor path to make sure there is nothing jamming unit.

Check dipswitch settings on side of acceptor.

**Make sure switch # 8 is OFF for Always Enable**

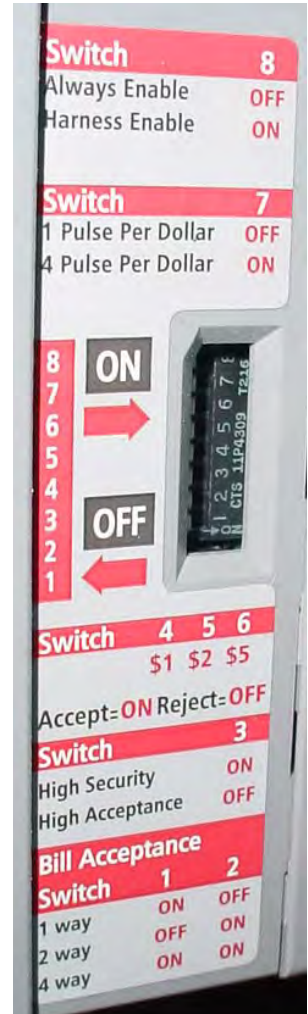
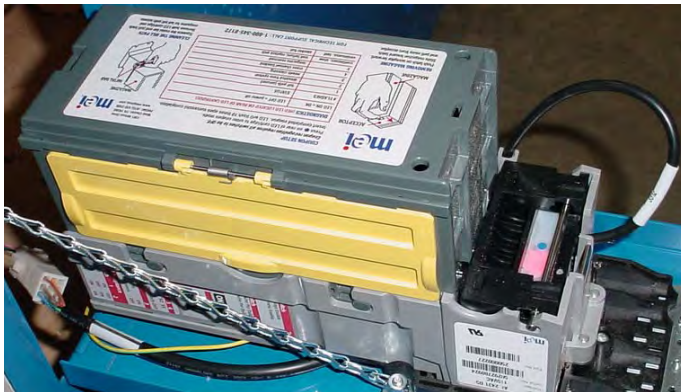

## ERROR CODES

Count the number of flashes on front bezel of Bill Acceptor and follow chart for repair.

**REMOVING MAGAZINE**  
Push latch on acceptor forward. Slide magazine toward latch and pull away from acceptor.

**COUPON SETUP**  
Coupon recognition requires all switches to be OFF. Press ● on rear of LED cartridge to enter coupon mode. Insert completed coupon. LED will flash 10 times upon successful completion.

**DIAGNOSTICS (RED LED LOCATED ON REAR OF LED CARTRIDGE)**

LED ON = OK	LED OFF = power off
# FLASHES	STATUS
1	bill path jammed
2	disabled from system
3	needs cleaning
4	cross channel blocked
5	magazine removed
continuous, slow	unit failure; replace unit
continuous, fast	stacker full

**CLEANING THE BILL PATH**  
Squeeze the metal bar and... Remove both LED cartridge magazine for full bill path...

**FOR TECHNICAL SUPPORT CALL: 1-800-345-8172**



# CARD SWIPE SYSTEM INSTRUCTIONS

The HopStar game is pre-wired to accept Card Swipe systems from many manufactures. Please follow these instructions to make full use of HopStar capabilities.

**Option #1:**

New card swipe systems may come with a standard 9 pin Molex connector.

Simply unplug this connector and plug into your card swipe reader.

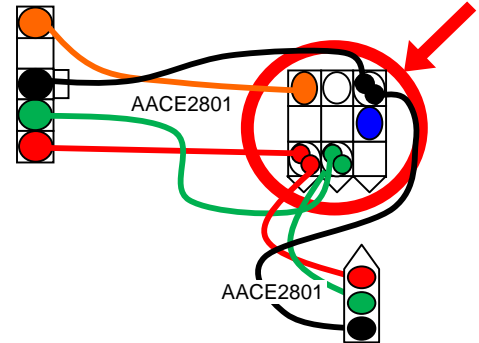

**Option #2:**

If your card swipe systems does not have a standard 9 pin Molex connector, then you will have to splice wires into the AACE2801 harness.

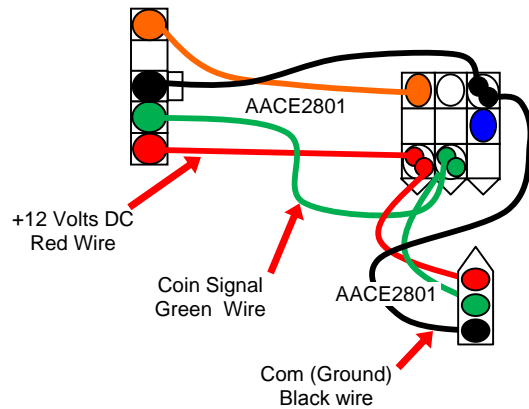

**Menu Changes**

Enter menu, go to "Pay In/Out" Menu  
Change "Credits" to 1  
Change "Card Reader" to Enabled



**Additional:**

Baytek sells an optional sticker sheet that will cover up the "Insert Coin" on many different types of games.  
**Part # A5DE0047**

Example: Stick on Big Bass Wheel to cover "Insert Coin" artwork.



# PARTS LIST

PART #	DESCRIPTION	PART #	DESCRIPTION
A5CB2050	Cash Box	AACE2821-1	Hop Pad Ribbon Cable
A5CN1031	Connector Adaptor	AACE2821-2	Hop Pad Ribbon Cable
A5SW200	Low Ticket Switch	AACE2822	Power Supply to Marquee Cable
A5BK1013	Push Button/Counter Bracket	AACE2823	Ground Wire Cable
A5TR2300	Game Trim	AACE2827	LED Wing Cables (2 Per)
A5TR2800	Rubber Edge Trim Around Monitor	AACE2828	Light Power Jumper Cable (2 Per)
W5TM1316	13/16" Blk/Silver T-Molding	AACE2830	Stick Light For Vacuum Form Under Monitor
W5TM4001	13/16" White T-Molding	AACE2832	Vacuum Form Light Power Jumper (Under Monitor)
A5FI9010	Inline Filter	AACE2833	Hop Pad Power Cable
A5LK2001	Cash Box Key A05/E00 Key Code	AACE2834	Hop Pad Ground Cable
A5LK5002	Lock 7/8", H95 Key Code	AACE2835	Hop Pad Ground Cable
AACO1000	Counters	AACE8811	Speaker Assembly
A5CO4203	Speaker Cover	AAPB2700	Push Button Assembly
A5PL4200	Bill Acceptor Plate (Upstacker)	AAPS1008-HS	Power Supply With Cable
A5PL8900	Bill Validator Blanking Plate	A5TD1	Ticket Dispenser
A5ME2803	Metal LCD Display Support	A5MO4205	42" Monitor
A5ME2810	Metal Side Trim	A5DE0042	Menu, Volume Pot Decal
A5ME2811	Metal Skirt	A5DE2800	Front Marquee Plexi Assembly
A5ME2813	Metal Back Rail Support Cover (2 Per)	A5DE2801	Back Marquee Plexi (Behind Front Marquee)
A5ME2814	Metal Front Hop Pad Cover	A5DE2802	Monitor Cover Plexi (Under Clear Plexi)
A5ME4182	Metal Cash Box Guide	A5DE2803	Side Cabinet Plexi (2 Per)
A5CORD5	AC Computer Cord	A5DE2804	Top Front Cabinet Decal
A5CEAU010	Audio Stereo Cable	A5DE2805	Middle Front Cabinet Decal (Around Coin Door)
AACBL4A-DOOR	Door Cable	A5DE2806	Bottom Front Cabinet Decal (Around Cash Box Door)
AACE2320	Monitor Surround Stick Lights	A5DE2807	Front Metal Skirt Decal
AACE2330	Light Power Jumper (Monitor)	A5DE2808	Black Floor Plexi
AACE2800	2300 Micro to Aux Cable	A5DE2809	Front Guard Plexi (Hidden Under Metal Skirt)
AACE2801	2300 Micro to Coin Door & Ticket Dispenser Cable	A5DE2810	Back Guard Plexi (Hidden Under Metal Skirt)
AACE2803	Power Supply to Left Side Lights Cable	A5DE2811	Left Metal Skirt Decal
AACE2804	2300 Micro Low Ticket Switch Cable	A5DE2812	Right Metal Skirt Decal
AACE2805	Button/Counter Cable	A5DE2813	Side Bridge Decal (2 Per)
AACE2806	Stick Light For Vacuum Form Under Monitor	A5DE2814	Cash Box Door Decal
AACE2807	Speaker Cable	A5VF2800	Top Shelf White Vacuum Form
AACE2808	Power to Hop Pad Interface Board Cable	AACB2204	Communication
AACE2809	2300 Micro To Communication Board Cable	AACB2803	IR Detector Board
AACE2810	MBA to Communication Board Cable	AACB2804	IR Emitter Board
AACE2812	Outlet Strip Cable	AACB2805	Hop Pad Interface Board
AACE2813	Side Tower Lights Cable	AAMB2300	2300 Micro Board
AACE2814	Stick Light For Vacuum Form Under Monitor	AAMB8-HD	Mother Board
AACE2815	DBA Cable		
AACE2816	Hop Pad Power Jumper Cable		
AACE2819	Ground Wire to Monitor Support Cable		
AACE2821-1	Hop Pad Ribbon Cable		

# PARTS PICTURES



W5TM1316



AASW200



AAPS1008-HS



A5FI9010



AAPB2700



AACBL4A-DOOR



AACE8811

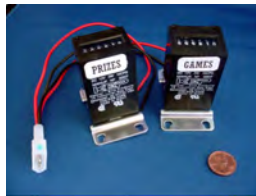

AACO1000



A5CORD5



A5CEAU010



AACB2204



A5CN1031

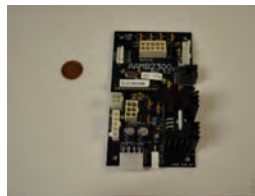

AAMB2300



A5TD1

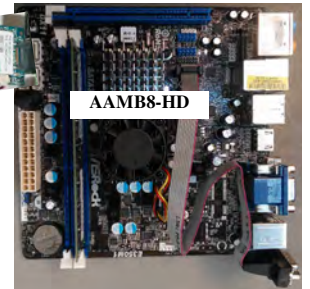

AAMB8-HD



A5DE2800

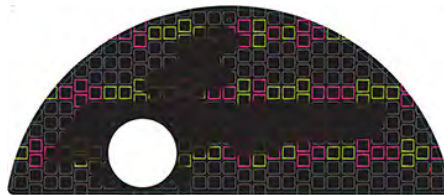

A5DE2801

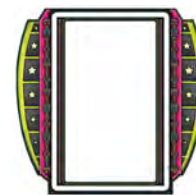

A5DE2802

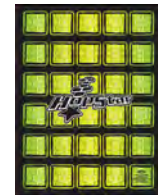

A5DE2803



A5DE2804



A5DE2807



A5DE2809

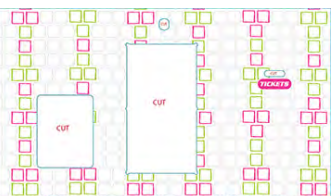

A5DE2805

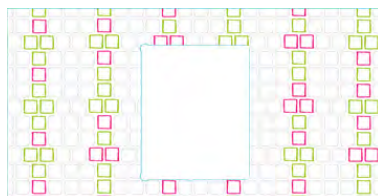

A5DE2806



A5DE2808

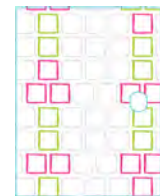

A5DE2814



A5DE2810



A5DE2811



A5DE2812



A5DE2813

# PARTS PICTURES



AACBL4A-DOOR

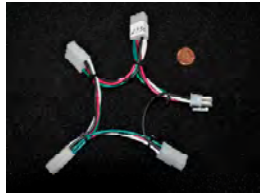

AACE230



AACE2800



AACE2801



AACE2803

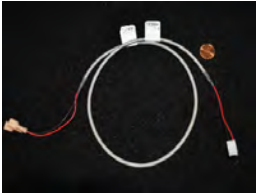

AACE2804



AACE2805



AACE2807



AACE2808



AACE2809



AACE2810



AACE2812



AACE2815



AACE2816



AACE2817



AACE2819



AACE2821



AACE2822



AACE2823



AACE2827



AACE2828



AACE2832



AACE2833



AACE2834

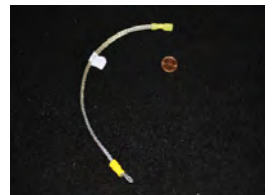

AACE2835



AACE2830

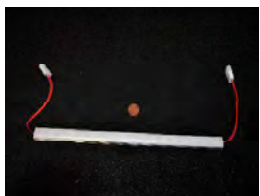

AACE2820

# DECAL PLACEMENT





## TECHNICAL SUPPORT

Excellent customer service is very important to Bay Tek Games!

We know that keeping your games in great operating condition is important to your business. When you need us, we are here to help. You can call us for free technical assistance, and you can count on us to have parts on-hand to support your game. We offer options that fit your needs.

### Electronics / Circuit Boards - Repair Options

**Repair & Return** – If you have Circuit Board issues with your Bay Tek game, you can send the board to us and we'll repair it right away. Most items sent to us are repaired and returned to you within two days. This option is your best value as we offer this fast turn-around service at the most reasonable price.

**Advance Replacement** – If you have Circuit Board issues with your Bay Tek game, but you don't have time to send in your board in for repair, give us a call and ask for an Advance Replacement. We'll send you a replacement board that same day (pending availability). When you get your new board, just repackage the defective board in the same box and send it back to us. We make it easy by including a UPS Return Shipping label for you to put on the box (not available for international shipments). This is your best option when you need to get your game up and running as quickly as possible!

**Spare Parts** – Take matters into your own hands and purchase new spare Circuit Boards for your Bay Tek games. Many of our games share the same main-board electronics. This means you can buy one set of spare electronics to support many of your Bay Tek games. Spare boards allow you to get your game up and running the quickest and provide you a valuable troubleshooting option. Call our technicians to get recommendations for what you should keep on hand for spare parts!

### Technical Support:

“You” are the best tool for troubleshooting! Your abilities to understand the game and your skills to repair the game are invaluable to us! If you need help, you know you can call us. It's not easy to diagnose a game remotely by phone, but our technicians do a great job. They'll need your help to perform some troubleshooting steps and convey to them exactly what's happening with your game.

### Returns, Credits, & Fees:

**NOTICE!** ALL ITEMS being sent to Bay Tek Games for repair or return, etc. require prior Return Authorization! Bay Tek Games will provide a Product Return Form with an authorizing Ticket Number for each item to be returned. Please be certain to include this document with all shipments!

**Late Fees and Non-Return Fees** - Advance Replacement and Warranty Replacement items require the defective items to be returned by Bay Tek games promptly to avoid Late Fees. We expect items to be returned with 10 working days. Late fees are invoiced monthly. Late fees are non-refundable under any circumstance! Any item not returned within 90 days will be invoiced in full as a replacement part.

**Bench Fees** - Bench fees will apply for each electronic item returned to Bay Tek Games (this includes unused Advance Replacement items). This charge covers our cost to inspect, evaluate and retest each item. Please note that returned items that do not pass our tests will be charged accordingly as replacement items or advance replacements.

**Restocking Fees** - Unused items returned for credit will be credited minus a restocking fee. Items must be returned within 30 days of purchase in order to qualify for any credit amount. No shipping charges will be credited.

## WARRANTY

Bay Tek Games warrants to the original purchaser that all game components will be free of defects in workmanship and materials for a period of 6 months from the date of purchase. If you fill out the registration card in the cashbox of the game, Bay Tek will add another 3 months to your warranty, free of charge.

Bay Tek Games will, without charge, repair or replace defective component parts upon notification to the parts/service department while the game is under warranty.

Warranty replacement parts will be shipped immediately, via ground service, along with a Product Return Form for the return of defective parts.

Defective parts must be shipped back to Bay Tek Games unless otherwise instructed. Items not returned to Bay Tek Games will be invoiced as replacement parts.

This warranty does not apply in the event of any misuse or abuse to the product, or as a result of any unauthorized repairs or alterations. The warranty does not apply if any serial number decal is altered, defaced, or removed from its original position.

 **ATTENTION** 

In order to maintain the safety & compliance certifications of this game, **ONLY** approved parts may be used. For approved replacement parts, refer to the parts list in this manual.

Should you need your game serviced, determine the serial number from the decal placed on the front of this manual, or locate it on the back of the game. Then contact our Service Department at: 920.822.3951 or e-mail: [service@baytekgames.com](mailto:service@baytekgames.com)

## NON-WARRANTY

Options and estimated charges will be provided to you for your approval.

Please remember that any items being sent to Bay Tek Games must include prior return authorization from our Parts & Service Department.

This approval will include a Product Return Form which is required to be included with any incoming shipments. Repaired parts will be shipped back using the same method in which they were received.

Repairs are warranted for 30 days from the date of return shipment.