

HP LaserJet 5L and 6L Printer Service Manual

Service Manual

HP LaserJet 5L
(C3941A)

HP LaserJet 6L
(C3990A)

© Copyright Hewlett-Packard
Company 1997

All Rights Reserved.
Reproduction, adaptation, or
translation without prior
written permission is
prohibited, except as allowed
under the copyright laws.

Publication number
C3990-90991

First edition, May 1997

Warranty

The information contained in
this document is subject to
change without notice.

Hewlett-Packard makes no
warranty of any kind with
regard to this material,
including, but not limited to,
the implied warranties or
merchantability and fitness for
a particular purpose.

Hewlett-Packard shall not be
liable for errors contained
herein or for incidental or
consequential damaged in
connection with the furnishing,
performance, or use of this
material.

WARNING

Electrical Shock Hazard

To avoid electrical shock, use
only supplied power cords and
connect only to properly
grounded (3-hole) wall outlets.

Conventions

This manual uses the following conventions:

Color is used to emphasize items which are important to the material under discussion.

The names of major printer parts and assemblies are CAPITALIZED.

Bold is used for emphasis, particularly in situations where *italic* type would be confusing.

Italic type is used to indicate related documents or emphasis.

Note

Notes contain important information set off from the text.

Caution

Caution messages alert you to the possibility of damage to equipment or loss of data.

WARNING!

Warning messages alert you to the possibility of personal injury.

Chapter Descriptions

1 Product Information

Orientation to the printer, as well as the service and repair philosophy, is discussed. Information on obtaining assistance and warranty is also here.

2 Site Requirements

Here are recommendations pertaining to installation requirements.

3 Operating Overview

This chapter has detailed information about the Control Panel. Sample self tests and printer reset information are also included.

4 Maintenance

Turn to this chapter for information about printer cleaning and care.

5 Functional Overview

Here you will find the basic theory-of-operation information required to understand the various printer systems and how they function together.

6 Removal and Replacement

This chapter contains the step-by-step procedures for replacing printer field replaceable units (FRUs). Assemblies are grouped by location in the printer.

7 Troubleshooting

Diagnose printer problems here. A preliminary troubleshooting table is followed by error messages, image defect samples, and diagnostic tools.

8 Parts and Diagrams

Look here to find any field replaceable unit (FRU) in the printer. Exploded view drawings are accompanied by complete part number tables.

A Parts Index

All parts are sorted and cross-referenced here by part number and name.

B Regulatory Information

Here are required statements regarding RFI and laser safety.

C Service Notes

Service Notes for HP LaserJet 5L concerning paper jams appear here.

Subject Index

Use the subject index to quickly locate any information in the manual.

List of Figures

Figure 1-1	HP LaserJet 5L Model and Serial Numbers	1-4
Figure 1-2	HP LaserJet 6L Model and Serial Numbers	1-5
Figure 1-3	Front/Side Views of the Printer	1-7
Figure 1-4	Front Door Assemblies	1-8
Figure 1-5	Back View of the Printer	1-9
Figure 2-1	Printer Space Requirements	2-4
Figure 2-2	Toner Cartridge Distribution	2-6
Figure 3-1	Self-test Page for HP LaserJet 5L	3-7
Figure 3-2	Self-test Page for HP LaserJet 6L	3-8
Figure 3-3	Engine Test Button	3-10
Figure 4-1	Five Percent Text Coverage	4-4
Figure 4-2	Static Eliminator Teeth	4-8
Figure 5-1	Printer Functional Block Diagram	5-3
Figure 5-2	DC Controller Loads	5-4
Figure 5-3	EconoMode vs Normal Mode	5-10
Figure 5-4	Image Formation Block Diagram	5-12
Figure 5-5	Simplified Paper Path	5-16
Figure 5-6	Solenoid and Sensors	5-17
Figure 5-7	General Timing Diagram – HP LaserJet 5L	5-20
Figure 5-8	General Timing Diagram – HP LaserJet 6L	5-21
Figure 6-1	Phillips and Posidriv screwdrivers	6-4
Figure 6-2	Back Cover Removal (1 of 2)	6-6
Figure 6-3	Back Cover Removal (2 of 2)	6-7
Figure 6-4	EP Door Assembly Removal	6-8
Figure 6-5	Memory Door Removal	6-9
Figure 6-6	Main Cover and Paper Input Assembly Removal	6-10
Figure 6-7	Control Panel Removal	6-11
Figure 6-8	Exit Roller Removal	6-12
Figure 6-9	Delivery Assembly Removal (1 of 2)	6-13
Figure 6-10	Delivery Assembly Removal (2 of 2)	6-14
Figure 6-11	Fuser Pressure Plate Removal	6-15
Figure 6-12	Fuser Pressure Plate Replacement	6-16
Figure 6-13	Heating Element Removal (1 of 3)	6-17
Figure 6-14	Heating Element Removal (2 of 3)	6-18
Figure 6-15	Heating Element Removal (3 of 3)	6-19
Figure 6-16	Pressure Roller Removal	6-20
Figure 6-17	Face-Up/Face-Down Lever Replacement	6-21
Figure 6-18	Fuser Exit Roller Removal	6-22
Figure 6-19	Paper Exit Sensor Flag Replacement	6-23
Figure 6-20	Laser/Scanner Assembly Removal	6-24
Figure 6-21	Solenoid Removal (1 of 2)	6-25
Figure 6-22	Solenoid Removal (2 of 2)	6-26
Figure 6-23	Pickup Roller Assembly Removal (1 of 2)	6-27

Figure 6-24 Pickup Roller Assembly Removal (2 of 2)	6-28
Figure 6-25 Paper Pickup Roller Assembly Replacement (Inside/Front View)	6-29
Figure 6-26 Paper Feed Frame Removal (1 of 4)	6-30
Figure 6-27 Paper Feed Frame Removal (2 of 4)	6-31
Figure 6-28 Paper Feed Frame Removal (3 of 4)	6-32
Figure 6-29 Paper Feed Frame Removal (4 of 4)	6-33
Figure 6-30 Transfer Roller Guide & Transfer Roller Removal (Inside/Back View)	6-34
Figure 6-31 Kick Plate Removal	6-35
Figure 6-32 Kick Plate Spring Replacement	6-36
Figure 6-33 Separation Pad Removal	6-37
Figure 6-34 Subpad Removal	6-38
Figure 6-35 Feed Assembly Removal (1 of 3)	6-39
Figure 6-36 Feed Assembly Removal (2 of 3)	6-40
Figure 6-37 Feed Assembly Removal (3 of 3)	6-41
Figure 6-38 Memory Door Guide Removal	6-42
Figure 6-39 Motor Removal	6-43
Figure 6-40 DC Controller Removal (1 of 3)	6-44
Figure 6-41 DC Controller Removal (2 of 3)	6-45
Figure 6-42 DC Controller Removal (3 of 3)	6-46
Figure 6-43 Formatter Board Removal	6-47
Figure 7-1 Paper Path and Components	7-5
Figure 7-2 DC Controller PCA Components	7-6
Figure 7-3 Heating Element Resistance Check	7-11
Figure 7-4 Engine Test	7-21
Figure 7-5 Toner Cartridge High Voltage Connection Points (1 of 2)	7-24
Figure 7-6 Toner Cartridge High Voltage Connection Points (2 of 2)	7-25
Figure 7-7 Overriding PS204 and SW101	7-27
Figure 7-8 Repetitive Image Defect Ruler	7-28
Figure 7-9 Repetitive Image Defect Ruler	7-29
Figure 8-1 Major Assembly Locations	8-7
Figure 8-2 Covers and Doors	8-8
Figure 8-3 Internal Components (1 of 3)	8-10
Figure 8-4 Internal Components (2 of 3)	8-12
Figure 8-5 Internal Components (3 of 3)	8-14
Figure 8-6 DC Controller/Formatter and Cables	8-16
Figure 8-7 Pickup Roller Assembly	8-18
Figure 8-8 Feed Assembly	8-20
Figure 8-9 Separation Guide Assembly	8-22
Figure 8-10 Delivery Assembly	8-24
Figure B-1 VCCI Statement (Japan)	B-4

List of Tables

Table 1-1	Printer Features	1-3
Table 1-2	Paper Capacities and Sizes	1-3
Table 1-3	Performance Specifications	1-6
Table 1-4	Electrical Specifications	1-6
Table 1-5	Acoustic Emissions	1-6
Table 1-6	Related Documentation	1-11
Table 2-1	Environmental Requirements	2-3
Table 2-2	Printer Dimensions	2-4
Table 3-1	Indicator Lights (1 of 2)	3-4
Table 3-1	Indicator Lights (Continued 2 of 2)	3-5
Table 3-2	Front Panel Button Usage	3-6
Table 4-1	Life Expectancy of Consumables	4-3
Table 4-2	Cleaning Printer Components	4-7
Table 5-1	Solenoid and Photosensors	5-17
Table 5-2	Printer Timing	5-19
Table 7-1	Printer Status Messages (1 of 2)	7-8
Table 7-2	Printer Status Messages (Continued 2 of 2)	7-9
Table 7-3	Unclearable Error	7-9
Table 7-4	Service and Error Messages (1 of 3)	7-10
Table 7-4	Service and Error Messages (Continued 2 of 3)	7-11
Table 7-4	Service and Error Messages (Continued 3 of 3)	7-12
Table 7-5	High-Voltage Power Supply Check	7-24
Table 7-6	Paper Curl Troubleshooting	7-26
Table 7-7	Cable Pinouts	7-30
Table 7-8	Cable Pinouts	7-31
Table 8-1	Accessories and Supplies	8-5
Table 8-2	Common Fasteners Used in the Printer	8-6
Table 8-3	Covers and Doors	8-9
Table 8-4	Internal Components (1 of 3)	8-11
Table 8-5	Internal Components (2 of 3)	8-13
Table 8-5	Internal Components (3 of 3)	8-15
Table 8-6	ECU Case	8-17
Table A-1	Alphabetical Parts List	A-2
Table A-2	Numerical Parts Index	A-6

Product Information

Contents

Printer Features	1-3
Paper Capacities and Sizes	1-3
Identification	1-4
Model and Serial	1-4
Specifications	1-6
Product Overview	1-7
Front/Side Views of the Printer	1-7
Front Door Assemblies	1-8
Back View of the Printer	1-9
Service Approach	1-10
Parts Exchange Program	1-10
Ordering Parts	1-10
Ordering Consumables	1-10
Ordering Related Documentation	1-10
Technical Assistance	1-12
Worldwide Support	1-13
North American Response Center	1-13
Warranty	1-14
Warranty Exclusions	1-14
Warranty Limitations	1-15
Voltage Conversions	1-15

Printer Features

Table 1-1

Printer Features

Features	Descriptions
Print Speed	4 ppm (HP LaserJet 5L); 6 ppm (HP LaserJet 6L)
Text & Graphics Resolution	300 or 600 dpi
Printer Language	Enhanced PCL 5
Monthly Usage (pages)	4,000 pages (HP LaserJet 5L); 6,000 pages (HP LaserJet 6L)
Memory: Standard ¹ Maximum Memory Capacity	1 Mbyte RAM (70nsec) 9 Mbyte total (available in increments of 1, 2, 4, and 8 Mbytes) 5 V JEDIA card ²
Internal Typefaces	26 Scalable Typefaces
Standard Interfaces	Parallel (Bi-tronics)
Power Control	SleepMode
Control Panel	3 LEDs 1 Front Panel Button
EconoMode (toner saving)	Yes

1 Printer memory is optimized with Memory Enhancement technology (MEt).

2 JEDIA (Japanese Electronic Device Industry Association) is a group of DRAM suppliers who have standardized DRAM and other CMOS products.

Paper Capacities and Sizes

Table 1-2

Paper Capacities and Sizes

Features	Descriptions
Paper Input Bin Capacity	Holds up to 100 sheets of regular weight paper or up to 10 envelopes
Paper Output Bin Capacity	Holds up to 100 sheets
Single Sheet Input Bin	1
Minimum Paper Size	3x5 in. (76 mm x 127 mm)
Maximum Paper Size	8.5x14 in. (216 mm x 356 mm)

Identification

Model and Serial

The model number and serial numbers are listed on identification labels located on the bottom of the printer. The model number is alphanumeric, such as C3941A for the HP LaserJet 5L printer, and C3990A for the HP LaserJet 6L printer.

The serial number contains information about the Country of Origin, the Revision Level, the Production Code, and production number of the printer.





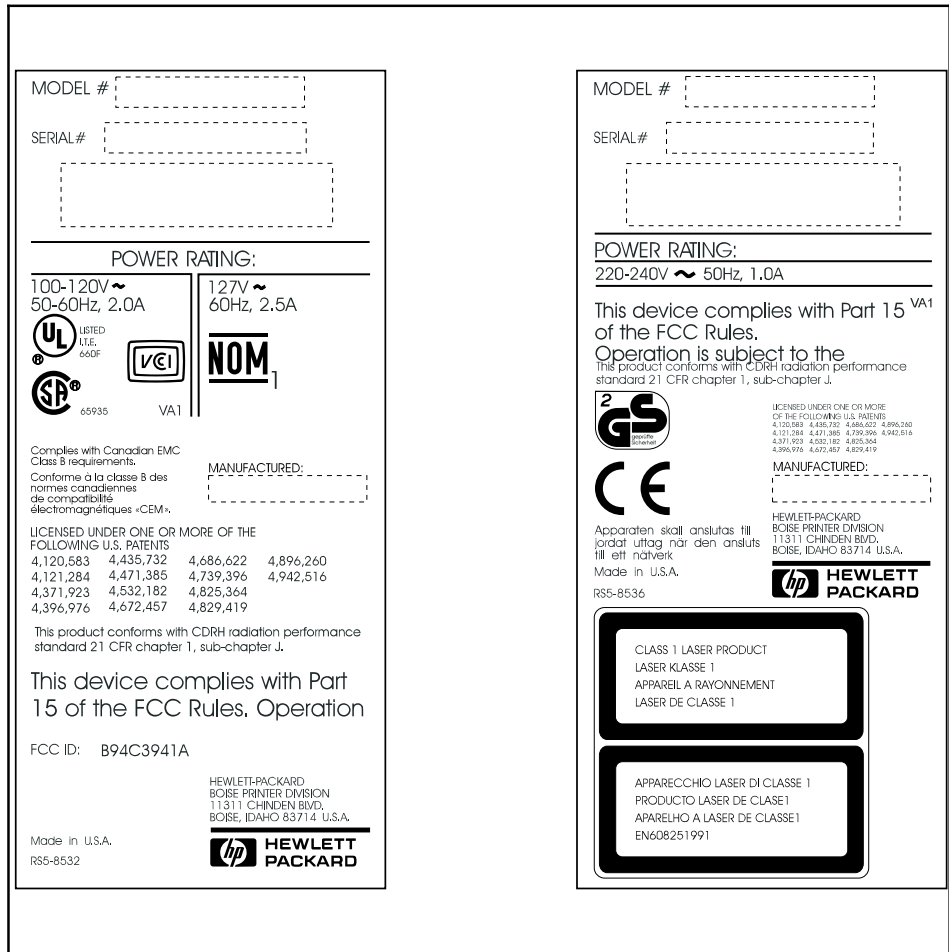



The labels also contain power rating and regulatory information.

Figure 1-1



HP LaserJet 5L Model and Serial Numbers

Figure 1-2

<p>MODEL # C3990A</p> <p>SERIAL# </p> <hr/> <p style="text-align: center;">POWER RATING:</p> <table style="width: 100%; border: none;"> <tr> <td style="width: 50%; border: none;"> <p>100-120V ~ 50-60Hz, 2.2A</p> </td> <td style="width: 50%; border: none;"> <p>127V ~ 60Hz, 2.2A</p> </td> </tr> </table> <div style="display: flex; justify-content: space-around; align-items: center;"> <div style="text-align: center;">  </div> <div style="text-align: center;">  </div> <div style="text-align: center;">  </div> </div> <p style="text-align: center;">NC1</p> <p style="font-size: small;">Complies with Canadian EMC Class B requirements. Conforme à la classe B des normes canadiennes de compatibilité électromagnétique «CEM».</p> <p style="font-size: small;">This product conforms with CDRH radiation performance standard 21 CFR chapter 1, sub-chapter J.</p> <div style="border: 1px solid black; padding: 5px; text-align: center; font-size: x-small;"> FC Tested To Comply With FCC Standards FOR HOME OR OFFICE USE </div> <p style="margin-top: 20px;">FCC ID: B94C3941A</p> <div style="display: flex; justify-content: space-between; font-size: x-small;"> <div>Made in Japan R55-8972</div> <div style="text-align: right;">  HEWLETT PACKARD </div> </div>	<p>100-120V ~ 50-60Hz, 2.2A</p>	<p>127V ~ 60Hz, 2.2A</p>	<p>MODEL # C3990A</p> <p>SERIAL# </p> <hr/> <p style="text-align: center;">POWER RATING:</p> <p style="text-align: center;">220-240V ~ 50Hz, 1.1A</p> <div style="border: 1px solid black; padding: 5px; text-align: center; font-size: x-small;"> FC Tested To Comply With FCC Standards FOR HOME OR OFFICE USE </div> <p style="font-size: x-small;">This product conforms with CDRH radiation performance standard 21 CFR chapter 1, sub-chapter J.</p> <div style="display: flex; justify-content: space-around; align-items: center;"> <div style="text-align: center;">  </div> <div style="text-align: center;">  </div> </div> <div style="display: flex; justify-content: space-around; align-items: center;"> <div style="text-align: center;">  </div> <div style="text-align: center;">  </div> </div> <p style="text-align: right; font-size: x-small;">MANUFACTURED: </p> <p style="font-size: x-small; text-align: right;">HEWLETT-PACKARD BOISE PRINTER DIVISION 11311 CHINDEN BVD. BOISE, IDAHO 83714 U.S.A.</p> <p style="font-size: x-small;">Made in Japan R55-8975</p> <div style="border: 1px solid black; padding: 5px; text-align: center; font-size: x-small; margin-top: 10px;"> hp HEWLETT PACKARD </div> <div style="border: 2px solid black; padding: 10px; margin-top: 10px; text-align: center; font-size: x-small;"> <p>CLASS 1 LASER PRODUCT LASER KLASSE 1 APPAREIL A RAYONNEMENT LASER DE CLASSE 1</p> </div> <div style="border: 2px solid black; padding: 10px; margin-top: 10px; text-align: center; font-size: x-small;"> <p>APPARECCHIO LASER DI CLASSE 1 PRODUCTO LASER DE CLASE1 APARELHO A LASER DE CLASSE1 EN60825: 1991</p> </div>
<p>100-120V ~ 50-60Hz, 2.2A</p>	<p>127V ~ 60Hz, 2.2A</p>		

HP LaserJet 6L Model and Serial Numbers

Specifications

Table 1-3

Performance Specifications

Category	Specification
Print Speed*: HP LaserJet 5L Print Speed*: HP LaserJet 6L	4 ppm 6 ppm
Monthly Usage (Duty Cycle): HP LaserJet 5L Monthly Usage (Duty Cycle): HP LaserJet 6L	4,000 pages 6,000 pages
Life Expectancy of Toner Cartridge (pages)**	2,500 pages @ 5% coverage
First Print	A4 <23 seconds Letter <23 seconds

* Actual speed depends on data complexity and software handling efficiency.

** Toner cartridge life can be extended by using EconoMode.

Table 1-4

Electrical Specifications

Volts	Freq	Amps	Watts (typical)	
120 Vac ± 10%	50/60 Hz ± 2 Hz	3.5 @ 120v*	printing = 100 (5L)	150 (6L)
100 Vac ± 10%	50/60 Hz ± 2 Hz		SleepMode = 6 (5L)	4 (6L)
220 Vac ± 10%	50 Hz ± 2 Hz	1.8 @ 230v	printing = 100 (5L)	150 (6L)
240 Vac ± 10%	50 Hz ± 2 Hz		SleepMode = 6 (5L)	4 (6L)

*Minimum recommended circuit capacity for product.

Table 1-5

Acoustic Emissions

During Printing	5.6 Bels Sound Power Level (per ISO 9296)
During Standby & SleepMode	Silent

Product Overview

Figure 1-3

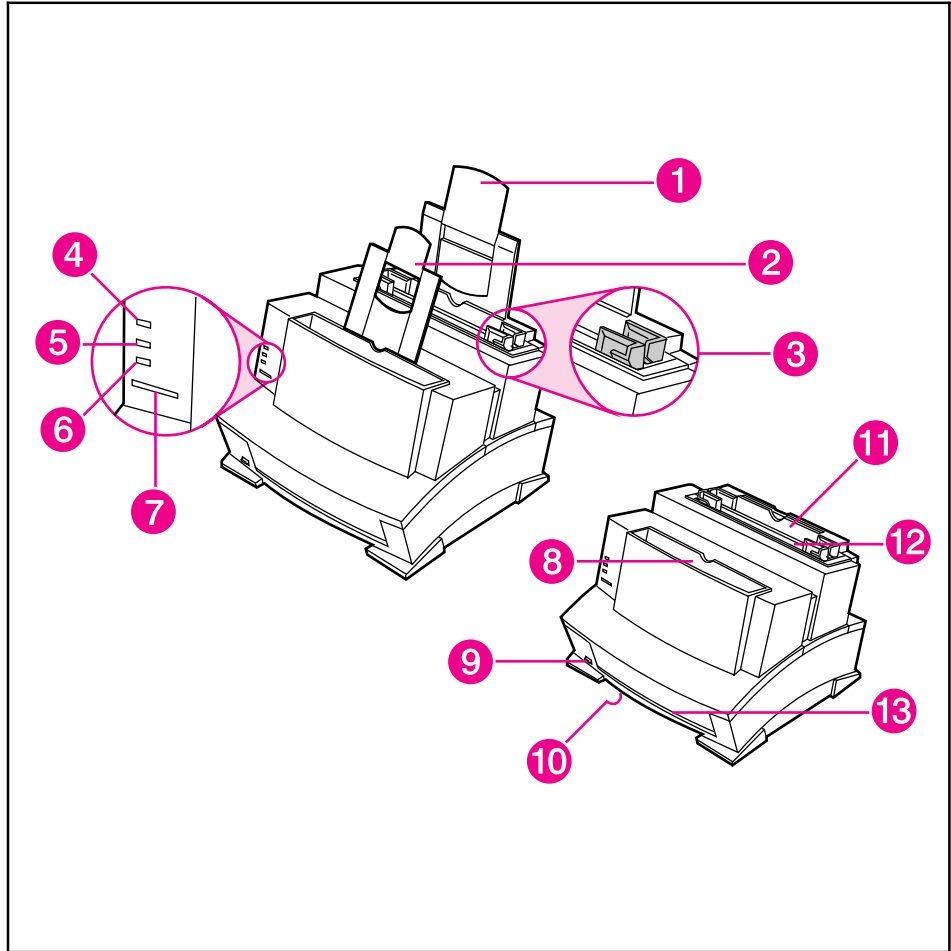

Front/Side Views of the Printer

- | | | |
|-------------------------|---|---------------------------------|
| 1. Paper Input Support | 7. Front Panel Button | 13. Front Output Slot (face-up) |
| 2. Paper Output Support | 8. Paper Output Bin | |
| 3. Paper Guides | 9. Paper Path Lever | |
| 4. Error (top) Light | 10. Serial and Model Number (under printer) | |
| 5. Data (middle) Light | 11. Paper Input Bin | |
| 6. Ready (bottom) Light | 12. Single Sheet Input Slot | |

Figure 1-4

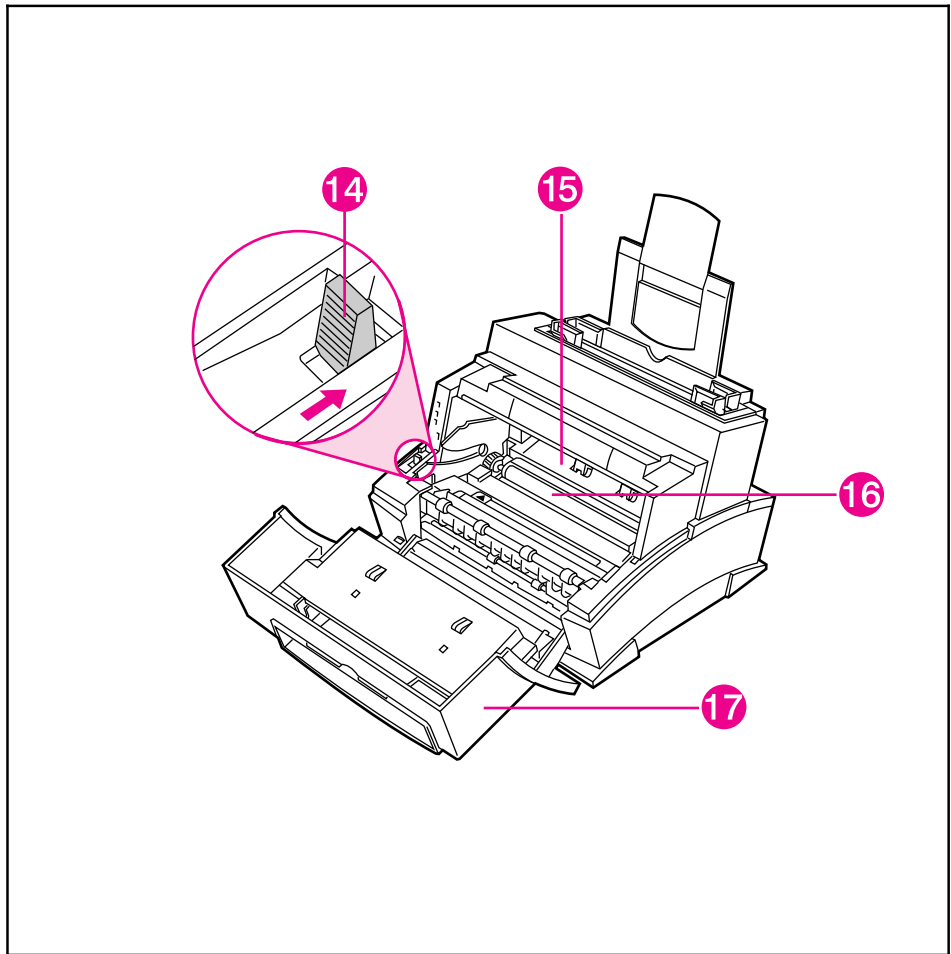

Front Door Assemblies

14. Paper Release Lever

15. Toner Cartridge Compartment

16. Transfer Roller (do not touch)

17. EP Door

Figure 1-5

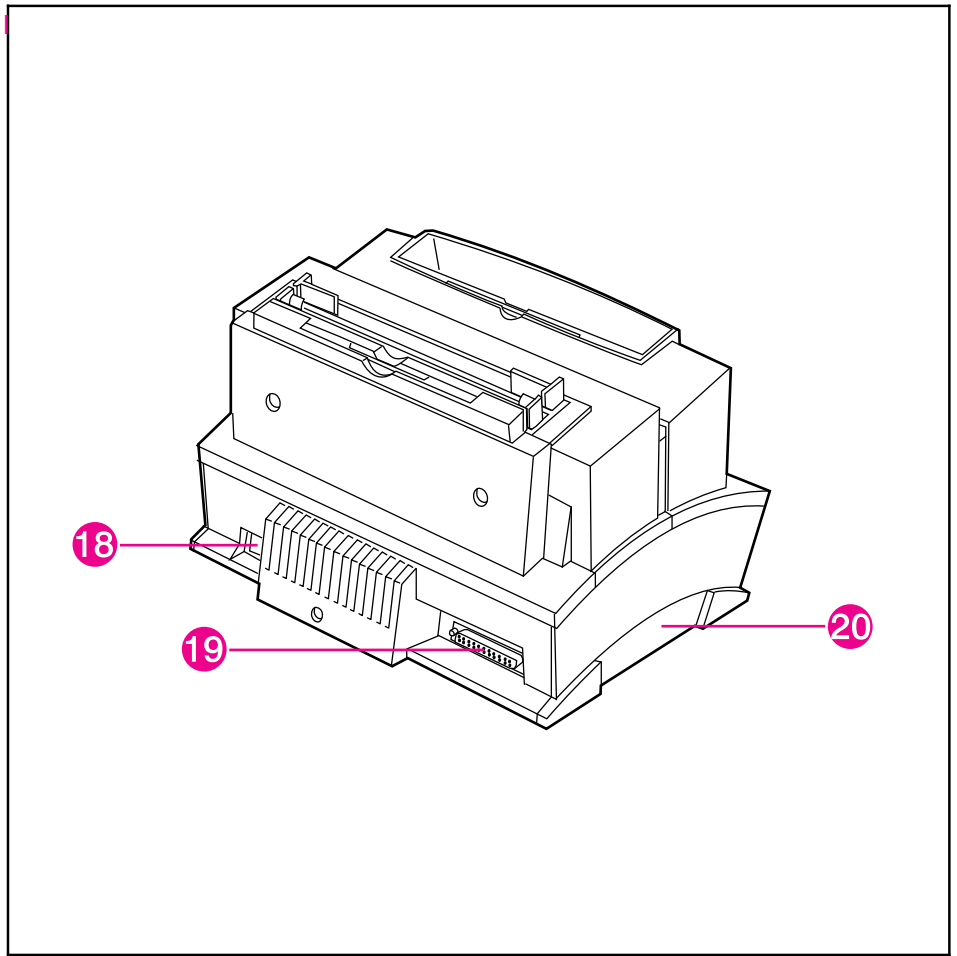

Back View of the Printer

18. Power Cable Connector

19. Parallel Cable Connector

20. Memory Expansion Cover

Service Approach

Repair of the printer normally begins with the use of the printer's internal diagnostics in conjunction with the troubleshooting procedures in Chapter 7. Once a faulty part is located, repair is generally accomplished by assembly level replacement of Field Replaceable Units (FRUs). Some mechanical assemblies may be repaired at the subassembly level. PCA component replacement is not supported by Hewlett-Packard. Part numbers for all FRUs are located in Chapter 8 of this manual.

Parts Exchange Program

HP offers remanufactured assemblies for some selected parts. These are identified in Chapter 8 and can be ordered through HP's Parts Direct Ordering (PDO), or Parts Center Europe (PCE).

Ordering Parts

Field replaceable part numbers are found in Chapter 8 of this manual. Replacement parts may be ordered through HP's Parts Direct Ordering (PDO), or Parts Center Europe (PCE).

Ordering Consumables

The printer has no consumables other than the toner cartridge, which may be ordered directly from Hewlett-Packard. Refer to Chapter 8 for ordering information.

Ordering Related Documentation

Table 1-6 on the following page lists part numbers and where to order related documentation. Phone numbers for the various sources are:

- Parts Direct Ordering (PDO)
1-800-227-8164 (U.S. only)
- Parts Center Europe (PCE)
(49 7031) 14-2253
- HP's Distribution Center (HPD)
970-339-7009 (U.S. only)
- URL for HP Access: <http://www.hp.com>
- URL for Software and Support: <http://www.hp.com/cposupport/cpoinde.html>

Table 1-6

Related Documentation

Description	Part Number	PDO	PCE	HPD
HP LaserJet Family Quick Reference Service Guide	5021-0369	X	X	
HP LaserJet 5L Printer User's Manual	C3941-90901	X		
HP LaserJet 6L Printer User's Manual	C3990-90901	X		
HP PCL5 Printer Language Technical Reference Information Package	5010-3994	X	X	
HP LaserJet Printer Family Paper Specifications Guide	5021-0368	X	X	X
LaserJet Basic Hardware Training Course	5961-0880	X	X	
HPLJ 5L and 6L Hardware Training Kit	C3990+49A-60001 (NTSC) C3990+49A-60002 (PAL)	X X	 X	
HP LaserJet 6L Printer Service Manual Bundle includes: Service Manual C3990-90991 Paper Specifications Guide 5021-0368 Quick Ref. Pocket Guide 5021-0369	C3990-99001	X	X	
HP LaserJet 6L Printer NTSC Kit includes: Box 9211-6385 6L Video Kit Label C3990-00010 6L Combined Test Kit C3990-67902 6L Video Tape C3990-99002	C3990-67901	X	X	
HP LaserJet 6L Printer PAL Kit includes: Cardboard Sleeve 5002-0556 VHS-PAL Tape 5010-6306 6L Spine Label C3990-00012 6L Face Label C3990-00013 6L Pal Kit Label C3990-00014	C3990-67903	X	X	
HP LaserJet 6L Combined Test Kit includes: Return Envelopes 5002-0562 Final Exam 5960-6642 6L Test Kit Label C3990-00011 6L Test Books (5 total) C3990-90992 Note: the five Test Books are labeled "A" through "E."	C3990-67902	X	X	
Specific Application Drivers				X

Technical Assistance

Online Services: for 24-hour access to information over your modem, we suggest these services.	World Wide Web URL —Printer drivers, updated HP printer software, and product and support information may be obtained from http://www.hp.com , or in Europe from http://www2.hp.com . In Japan printer drivers may be obtained from ftp://www.jp.hp.com/drivers/ . Korea: www.hp.co.kr . Taiwan: www.hp.com.tw , with a local driver website of www.dds.com.tw .	
	HP Bulletin Board Service —Our electronic download service provides convenient access to HP printer drivers, updated HP printer software, product information, and troubleshooting hints. Dial (208) 344-1691 (U.S. and Canada) and set your communication software to N,8,1. European Bulletin Board Service numbers are listed at http://www2.hp.com . Taiwan: (886-2) 923-3233. Korea: HITEL or CHOLIAN (Go HPK). Australia: (613) 9890 0276. New Zealand: (649) 356-3660.	
	America OnLine —(America OnLine/Bertelsmann available in France, Germany, and UK)—Printer drivers, updated HP printer software, and support documentation are available to help you answer your HP product questions. Use Keyword HP to start your tour.	
	CompuServe —Printer drivers, updated HP printer software, and interactive sharing of technical information with other members are available on CompuServe's HP User's forums (GO HP), or call (800) 524-3388 and ask for representative #51. (CompuServe is also available in the UK, France, Belgium, Switzerland, Germany, and Austria.)	
Obtaining Software Utilities and Electronic Information: U.S. and Canada	Phone: (970) 339-7009 Fax: (970) 330-7655	Mail: Hewlett-Packard P.O. Box 1754 Greeley, CO 80632 USA
Asia-Pacific Countries	Fulfill Plus (65) 740-4477 (Singapore, Malaysia, Indonesia, Hong Kong).	
Australia/New Zealand	Call (612) 565-6099.	
HP Direct Ordering for Accessories and Supplies	Call (800) 446-0522 (U.S.) or (800) 387-8164 (Canada).	
HP Support Assistant CD-ROM	This support tool offers a comprehensive online information system designed to provide technical and product information on HP products. To subscribe to this quarterly service in the U.S. or Canada, call (800) 457-1762. Fulfill Plus, (65) 740-4477 (Singapore, Malaysia, Indonesia, Hong Kong).	
HP Service Information	To locate HP-authorized dealers, call (800) 243-9816 (U.S.); (800) 387-3867 (Canada).	
HP Service Agreements	Call (800) 446-0522 (U.S.); (800) 268-1221 (Canada).	
HP FIRST: HP FIRST Fax will deliver detailed troubleshooting information on common software applications and troubleshooting tips for your HP product. Call from any touch-tone phone and request up to three documents per call. These documents will be sent to the fax of your choice.		
Australia Austria Belgium (Dutch) Belgium (French) Canada China Denmark English outside of UK Finland France Germany Hong Kong India Indonesia Italy Japan	(03) 9272-2627 0660-8128 0800-1-1906 0800-1-7043 (800) 333-1917 (86 10) 6505 5280 800-10453 (31 20) 681-5792 9800-13134 05-905900 0130-810061 (852) 2506-2422 (011) 622-6420 (21) 352-2044 1678-59020 (813) 3335-8622	Korea Malaysia Netherlands New Zealand Norway Philippines Singapore Spain Sweden Switzerland (German) Switzerland (French) Taiwan Thailand United Kingdom United States
		(02) 769-0543 (03) 298-2478 0800-22-2420 (09) 356 6642 800-11319 (65) 291-7951 (65) 275-7251 900-993123 020-795743 0800 55-1527 0800 55-1526 02-719-5589 (02) 661-3511 0800-960271 (800) 333-1917

Worldwide Support

U.S. and Canada:		Call (208) 323-2551 Mon-Fri 6 am to 10 pm and Saturday 9 am to 4 pm (Mountain Time) free of charge during the Warranty Period; however, your standard long-distance phone charges still apply. Please have your serial number ready when calling.	
Customer Support & Product Repair Assistance			
(Please refer to the warranty chapter of this manual for additional product repair information.)		Post-warranty telephone assistance is available to answer your product questions. Call (900) 555-1500 (\$2.50* per minute, U.S. only), or call (800) 999-1148 (\$25* per call, Visa or MasterCard, U.S. and Canada) Mon-Fri 7 am to 6 pm and Saturday from 9 am to 3 pm (Mountain Time). Charges begin only when you connect with a support technician.	
		*Prices subject to change.	
European Customer Support Center Language and In-Country Options Available Open Monday-Friday 8:30-18:00 CET			
HP provides a free telephone support service during the warranty period. By calling a telephone number listed below, you will be connected to a responsive team waiting to help you. If you require support after your warranty has expired, you can receive support for a fee through the same telephone number. The fee is charged on a per-incident basis. When calling HP please have the following information ready:			
• Product name and serial number Date of purchase Description of the problem			
Dutch	Belgium:	02 626 8806	Norwegian
	Netherlands:	020 606 8751	Danish
English	Ireland:	01 662 5525	Finnish
	UK:	0171 512 5202	Swedish
	International:	44 171 512 52 02	Italian
French	France:	04 50 43 9853	Spanish
	Belgium:	02 626 8807	Portuguese
	Switzerland:	084 880 1111	
German	Germany:	0180 5 25 81 43	
	Austria:	0660 6386	
			Norway: 22 11 6299
			Denmark: 3929 4099
			Finland: 0203 47288
			Sweden: 08 619 2170
			Italy: 02 26410350
			Spain: 902 321 123
			Portugal: 01 441 7199
In-Country Support Numbers			
Africa/Middle East	(41 22) 780-7111	Malaysia	(603) 295-2566
Argentina	(54 1) 781-4059/69	Mexico D.F.	(52 5) 326-4600
Australia	(03) 9272 8000	Mexico Guadalajara	(52 3) 669 95 00
Brazil	(55 11) 709-1444	Mexico Monterrey	(52 83) 378 42 40
Canada	(208) 323-2551	New Zealand	(64 9) 356-6640
China	(8610) 6261-4174; 6261-4175; 6261-4176; 6262-5666	Philippines	(63 2) 894-1451
Czech Republic	(42 2) 471 7321	Poland	(48 22) 37-5065
Greece	(30 1) 689 64 11	Portugal	(351 1) 301 7330
Hong Kong	800-7729	Russia	(7 095) 923-5001
Hungary	(36 1) 252 4505	Singapore	(65) 272-5300
India	(011) 6472366	Switzerland	(41 1) 753 7111
Indonesia	(21) 350-3408	Taiwan	(02) 717-9609
Japan	(31 20) 581-3318	Thailand	(662) 661-4011; 661-4012
Korea	(82 2) 3270-0700; outside Seoul, call 080-999-0700	Turkey	(90 1) 224-5925

North American Response Center

The North American Response Center (NARC) is available for technical support to assist service technicians. The NARC can be reached at 1-800-544-9976. To access this service, HP resellers must have a valid CZ number.

Warranty

This warranty gives you specific legal rights. You may also have other rights, which may vary from area to area.

Hewlett-Packard warrants the 5L and 6L LaserJet printers against defects in materials and workmanship for a period of one year from the date of purchase by the end user and is not transferable.

During the warranty period, Hewlett-Packard will, at its option, either repair or replace hardware products that prove to be defective.

Should Hewlett-Packard be unable to repair or replace the product within a reasonable amount of time, a refund of the purchase price may be made upon return of the product. To have your printer serviced by Hewlett-Packard, you must make arrangements to have it serviced in the country of purchase.

Warranty Exclusions

The warranty on your HP LaserJet printer shall not apply to defects or damage resulting from:

- Improper or inadequate maintenance by customer.
- Customer-supplied software or interfacing.
- Unauthorized modification or misuse.
- Operation outside of the environmental specifications for the product.
- Operation of nonsupported printing media.
- Duty cycle abuse (see later explanation).
- Operating the printer from a mechanical switchbox without a designated surge protector.
- Improper site preparation and maintenance.
- Use of non-HP toner cartridges (see explanation) or DRAM (JEDIA) memory cards.

The use of non-Hewlett-Packard toner cartridges does not affect either the warranty or any maintenance contract purchased from Hewlett-Packard. However, if an HP LaserJet printer failure or printer damage is found to be directly attributable to the use of any non-HP product, the repair will not be covered under the warranty or HP maintenance contract. Hewlett-Packard cannot recommend use of non-HP toner cartridges, either new or remanufactured, because they are not HP products and Hewlett-Packard cannot influence or control their quality.

Operation of the printer beyond the limit of its duty cycle (printing more than the equivalent of 4,000 single-sided pages per month on the HP LaserJet 5L or more than the equivalent of 6,000 single-sided pages per month on the HP LaserJet 6L) shall be deemed printer abuse and all repairs thereafter will be billed on a time and materials basis.

If you are using a mechanical switchbox, ensure that it is equipped with a surge protector. Damage to your printer could occur from the use of unprotected mechanical switchboxes.

The warranty period begins either on the date of delivery or, where the purchase price includes installation by Hewlett-Packard, on the date of installation.

Warranty Limitations

The warranty set forth above is exclusive and no other warranty, whether written or oral, is expressed or implied. Hewlett-Packard specifically disclaims the implied warranties of merchantability and fitness for a particular purpose.

Some areas do not allow limitations on how long an implied warranty lasts, so the preceding limitation or exclusion may not apply to you. However, any implied warranty of merchantability or fitness is limited to the one-year duration of this written warranty.

In no event will Hewlett-Packard or its suppliers be liable to you for any consequential or incidental damages, including any lost profits or lost savings, or for any claim by any party, even if a representative of HP or its suppliers has been advised of the possibility of such damages.

Some areas, states, or provinces do not allow the exclusion or limitation of incidental or consequential damages, so the preceding limitation or exclusion may not apply to you.

Voltage Conversions

HP LaserJet printers are manufactured to different specifications for different countries. Because of these differences, HP does not recommend transporting products sold within one country to another country.

In addition to the 115-220 voltage environment concerns, the country of final destination may have different import and export restrictions, power frequencies, and regulatory requirements.

Note

The HP LaserJet family printers must be serviced by an authorized repair depot or reseller within the country where the printer was originally purchased.

Because of the different specifications and warranty coverage limitations, Hewlett-Packard does not offer a conversion, or support the conversion, of HP LaserJet family printers. We advise those customers planning to transport equipment to different countries to purchase the products in the country of final destination.

Site Requirements

Contents

Site Requirements	2-3
Operating Environment	2-3
Printer Space Requirements	2-4
The HP C3906A/F Toner Cartridge	2-5
Storage Conditions	2-5
Storing Opened Toner Cartridges	2-5
Toner Cartridge Handling Suggestions	2-6

Site Requirements

Operating Environment

The environmental requirements listed in the table below must be maintained to ensure the proper operation of this printer.

Table 2-1

Environmental Requirements

LaserJet 5L/6L & Cartridge	Operating	Storage
Temperature	50 to 90.5° F (10 to 32.5° C)	32 to 104° F (0 to 40° C)
Humidity	20 to 80% RH (with no condensation)	10 to 80% RH (with no condensation)

Consider the following points before installing the printer:

- Install in a **well-ventilated, dust-free** area.
- Install on a **hard, flat and continuous surface**, with all four printer feet level. Do not install on carpet or other soft surfaces.
- Ensure **adequate power is supplied**. Printer power requirements are listed under “Specifications,” in Chapter 1. Uninterruptible power supplies (UPS) should not be used with this printer.
- **Install away from direct sunlight**, open flames, or ammonia fumes. If the printer is placed near a window, make sure the window has a curtain or blind to block any direct sunlight.
- Install with enough **space around the printer** for proper access and ventilation. (See Figure 2-1.)
- Install printer **away from the direct flow of exhaust** from air ventilation systems.

Printer Space Requirements

Figure 2-1

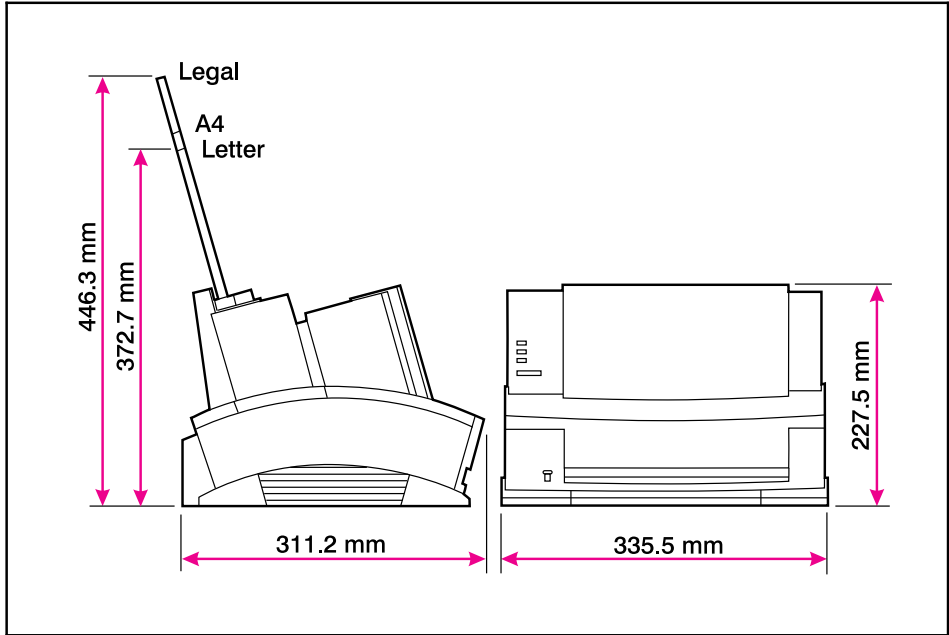

Printer Space Requirements

Table 2-2

Printer Dimensions

Description	Dimension
Width	13.2 in. (335.5 mm)
Depth	12.3 in. (311.2 mm)
Height (storage) (operational)	8.9 in. (227.5 mm) 14.6 in. (372.7 mm)*
Weight (with toner cartridge)	15.9 lbs. (7.2 kg)
Toner cartridge weight**	1.5 lbs. (.7 kg)

* With letter input assembly extended.

** Some quantity of toner will reside in the waste toner area of a toner cartridge when the toner supply is exhausted. Therefore, using toner cartridge weight may be an unreliable indication of remaining toner supply.

The HP C3906A/F Toner Cartridge

Toner cartridges contain components that are sensitive to light, temperature, and humidity. Follow the recommendations in this section to ensure the highest quality and longest life of HP toner cartridges.

Keep the printer within the following environmental conditions for optimum performance.

Storage Conditions

The toner cartridge is affected by its environment. Packaging protects the toner cartridge from light and increases its storage life. It is important to store the cartridge in its original packaging until the cartridge is ready to be installed in the printer.

When storing the toner cartridge in a warehouse or work area, make sure the storage place meets the conditions specified in Table 2-1.

Storing Opened Toner Cartridges

Because the cartridge does not have a shutter to cover the laser beam access slot, it should be kept inside the printer until empty. Toner cartridges which have had the toner sealing tape removed are also more vulnerable to environmental extremes (such as high humidity).

If the toner cartridge must be removed from the printer, always store the cartridge:

- Inside the protective bag in which it was originally packaged.
- In a dark cabinet, away from direct sunlight.
- Correct side up and in a horizontal position (not standing on end).
- At a temperature between 32° to 104° F (0° and 40° C).
- Away from ammonia or other organic solvent fumes.

Caution

Never ship the printer with a toner cartridge installed. Excessive vibration during shipping can cause toner to leak, contaminating the printer. Never expose the toner cartridge to direct sunlight or to room light for more than a few minutes. Bright light and direct sunlight can permanently damage a toner cartridge.

Note

The C3906F toner cartridge is designed specifically for use in the environmental conditions of the Asia Pacific region and is only available in that region.

Toner Cartridge Handling Suggestions

- Before installing a cartridge, distribute the toner evenly by rotating the cartridge back and forth five to six times. (See Figure 2-2.) Repeat this action when toner begins to run low.

Figure 2-2

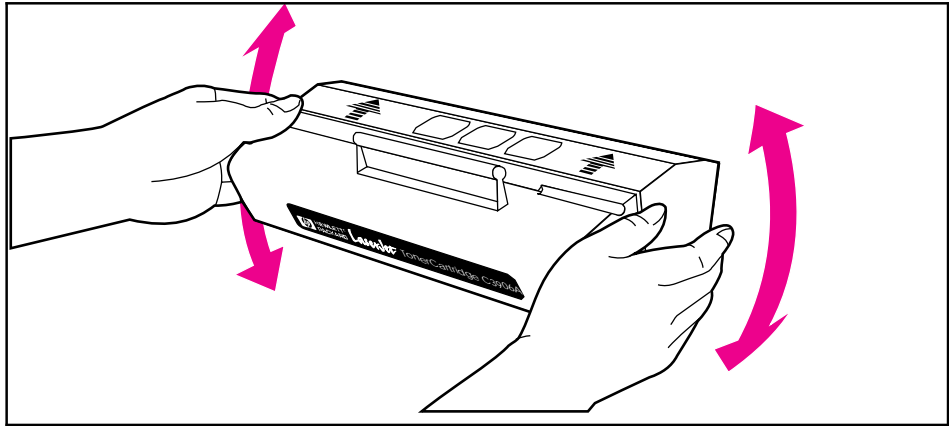

Toner Cartridge Distribution

- Do not touch the surface of the photosensitive drum in the cartridge. Protect the drum from light and contamination.
- Do not expose the cartridge to unnecessary vibrations or shock.
- Do not expose the photosensitive drum to strong light. Blurred areas on the page may indicate that the drum has been exposed to light for too long. This causes permanent damage to the photosensitive drum. Replace the cartridge.
- Never manually rotate the drum, especially in the reverse directions; internal damage and toner spills may result.
- Do not install the toner cartridge in the printer for shipping.

Operating Overview

Contents

Using the Control Panel	3-3
Control Panel Layout	3-3
LED Lights	3-4
The Front Panel Button	3-6
Printing a Self-Test Page	3-7
Continuous Self Test	3-9
Printing an Engine Test	3-10
Resetting the Printer	3-11
To Reset the Printer	3-11

Using the Control Panel

Control Panel Layout

The Control Panel consists of three status lights and a Front Panel Button located at the front of the printer.

The Control Panel consists of one button and three status lights.

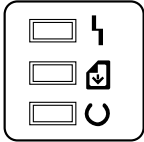

ERROR (Yellow)

DATA (Green)

READY (Green)

These lights can be in only one of the following states:

OFF



ON



Blinking



LED Lights

The LED lights provide a quick way to check the printer's status.

Table 3-1

Indicator Lights (1 of 2)

When this Indicator:	Looks like this:	It means this:	Do this:
	On Blinking	Ready Ready to print. Print job in progress.	Let job finish printing.
	On	Form Feed There is unprinted data in the buffer.	Briefly press the Front Panel Button to print the remaining data.
	Blinking	Manual Feed The printer is in manual feed mode.	Make sure you have the correct paper in the Single Sheet Input Bin, and briefly press and release the Front Panel Button to print.
	On	Error (light continuously on) Printer is out of paper. Printer's EP door is open. Toner cartridge is either missing or not installed correctly. There is paper jammed in the printer.	Add paper. Close the door. Install a cartridge, being careful to position it correctly. Clear the jam and resume printing. If the Error light remains lit after checking for these problems, and there's no paper jam, disconnect the power for 10 seconds, then reconnect to the power source. If, after taking these actions, the light remains on, refer to Chapter 7, "Troubleshooting."

Table 3-1

Indicator Lights (Continued 2 of 2)

When this indicator:	Looks like this:	It means this:	Do this:
	Blinking	<p>Error (light blinking) Page Too Complex</p> <p>The page may be too complex for the printer's memory capacity or the printer may not be able to create the image fast enough to keep pace with the engine printing process.</p>	<p>Briefly press and release the Front Panel Button to continue printing. There may be some data loss on the page.</p> <p>Hint: To avoid this in the future:</p> <ol style="list-style-type: none"> 1. See your printer driver help for more suggestions regarding printer memory usage. 2. Reduce resolution to 300 dpi with your software. 3. Install additional printer memory. (See chapter 6 for information on installing additional memory.)
	All off	<p>Sleep Mode Either the printer is in SleepMode or the power source has been disabled.</p>	<p>No action is necessary. When you press the Front Panel Button, send data to the printer, or open the printer door, the status light comes on.</p>
	All on	<p>Hardware Error There is an internal problem that won't allow printing.</p>	<ol style="list-style-type: none"> 1. If you have added an additional memory card, try removing it. 2. Disconnect the power for 10 seconds, then reconnect it. 3. If all of the lights come on steadily again, try disconnecting the power for 15 minutes. <p>If this error remains after completing the tasks above, see Chapter 7, "Troubleshooting."</p>
	All Blinking	<p>Memory Error An incompatible memory card has been installed.</p>	<p>For memory card specifications, see the <i>HP LaserJet 5L User's Manual</i>, appendix D, or the <i>HP LaserJet 6L User's Manual</i>, page 1-10. The memory card must be a 70 nsec or faster card.</p>

The Front Panel Button

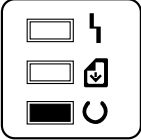
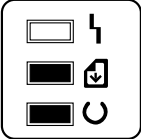
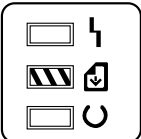
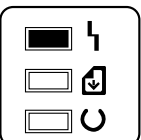
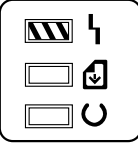
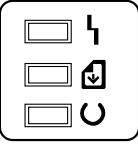
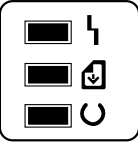
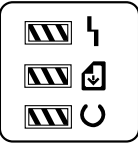
Depending on what state the printer is in, pressing the Front Panel Button allows you to control printing tasks by either starting or resuming a printer function. Use the Front Panel Button to accomplish the following tasks:

Table 3-2

Front Panel Button Usage

Function	Lights	Action	Result
Wake Up	All lights are off while plugged into power source.	Briefly push and release the button.	The printer will wake up to a ready state.
Self Test	Ready (bottom) light is on and the other lights are off.	Briefly push and release the button.	Prints a self-test page.
Printer Reset	The Ready (bottom) Light will remain lit, if there are no printer errors.	Press and hold the button until the three Front Panel Lights blink quickly in succession.	The reset will return the printer to the factory default settings. This clears all data from memory, including any downloaded fonts and macros.
Resume (from Manual Feed)	The Data (middle) Light blinks.	Briefly push and release the button.	Override manual feed to print from paper cassette.
Continue (from memory error)	Error (top) light blinks.	Briefly push and release the button.	Allows the printer to recover and continue printing the job.
Form Feed	The Data (middle) Light and the Ready (bottom) Light both remain on.	Briefly push and release the button.	The remaining data in printer memory will print.

Printing a Self-Test Page

A self-test page can be useful in troubleshooting printer problems and determining which fonts have been downloaded to the printer.

Figure 3-1

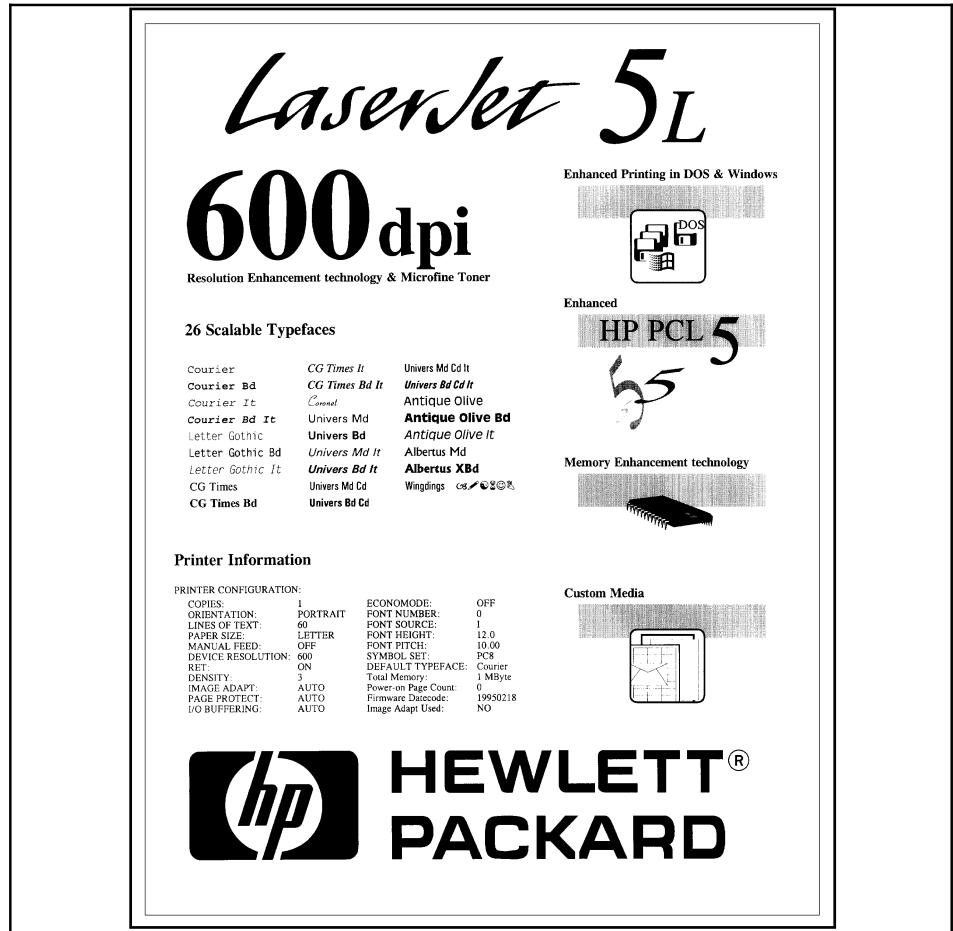

Self-test Page for HP LaserJet 5L

Figure 3-2



Self-test Page for HP LaserJet 6L

The self-test page lists the current printer configuration. (If any fonts have been downloaded to the printer a second page will print.)

To print a self-test page:

- 1 Make sure the Ready (bottom) Light is on, and all other lights are off. Wake up the printer if necessary by pressing the Front Panel Button.
- 2 Briefly press and release the Front Panel Button. The Data (middle) Light comes on, the Ready (bottom) Light blinks. Wait for a self-test page to print.

Continuous Self Test

A continuous self test can be useful for troubleshooting paper path and other problems. To print a continuous self test:

- 1 Disconnect the printer from the power source.
- 2 Press and hold down the Front Panel Button while connecting power.
- 3 Continue holding the button for about five seconds.

All lights will illuminate at once, then each will light in sequence.

- 4 Release the button. The printer conducts its internal diagnostics routine, then prints the self-test page continuously until stopped.
- 5 To stop the continuous self test (and reset the printer), press and hold the Front Panel Button for a few seconds until all lights begin lighting in sequence once again.

Note

The self test does **not** print at the printer's rated speed of four pages per minute (HP LaserJet 5L) or six pages per minute (HP LaserJet 6L). The engine test prints at the printer's rated speed.

Printing an Engine Test

The engine test print can be used to verify that the print engine is functioning correctly. The Formatter PCA is completely bypassed during an engine test. Consequently, this test is useful for isolating engine printer problems. The engine test prints a full page of vertical lines down the entire printable area. This page is useful for checking and adjusting registration.

Note

Perform the engine test with the printer covers in place, as shown in Figure 3-6. Refer to “Engine Test” in Chapter 7 for the engine test procedure.

Figure 3-3

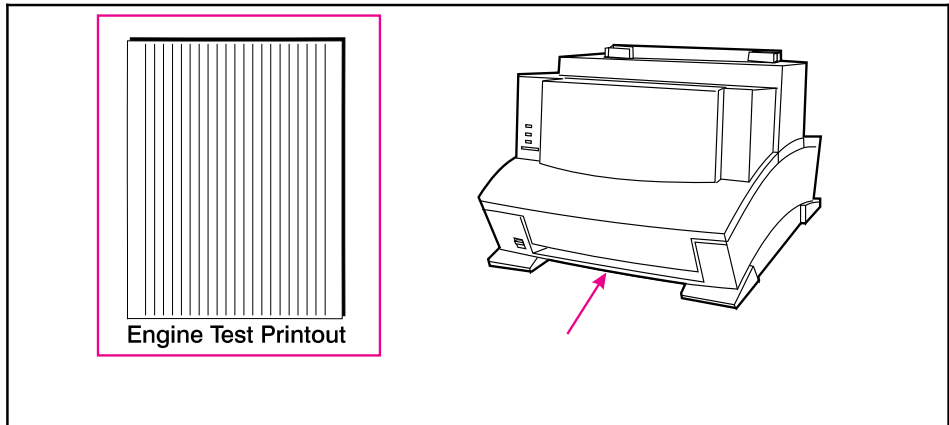

Engine Test Button

Resetting the Printer

Resetting the printer accomplishes the following:

- Clears all data from the printer's memory (including unprinted data, downloaded fonts, and macros).
- Stops any printing that is taking place and ejects the page.
- Removes some error conditions.
- Resets the printer to its factory default settings.

To Reset the Printer

Press and hold the Front Panel Button until the three control panel lights blink quickly in succession (about 5 seconds), then let go of the button. After resetting, the Ready (bottom) Light will remain lit if there are no printer errors. (Make sure there is paper in the printer or the error light will remain on.)

Printer Maintenance

Contents

Life Expectancy of Consumables	4-3
Toner Cartridge Life	4-4
Saving Toner with EconoMode	4-4
Refilled Toner Cartridges	4-5
Recycling Toner Cartridges	4-5
Cleaning the Printer	4-6
Cleaning Printer Components	4-7
Cleaning Spilled Toner	4-8

Life Expectancy of Consumables

Always inspect the components listed in Table 4-1 for wear when servicing the printer. Replace these components as needed, based on printer failures or wear, not strictly on usage.

Table 4-1

Life Expectancy of Consumables

Description	HP LaserJet 5L Part Number	HP LaserJet 6L Part Number	Est Life (pgs)	Remarks
Toner Cartridge (user replaceable)	C3906A	C3906A	2,500*	When print becomes faint, shake cartridge to distribute remaining toner.
Transfer Roller	RF5-1534-000CN	RF5-1534-000CN	50,000	May affect print quality and/or paper movement.
Paper Pickup Assembly	RG5-1940-000CN	RG5-3486-000CN	50,000	Look for glazing and/or cracks.
Separation Pad & Sub pads	RY7-5008-000CN	RY7-5008-000CN	50,000	May affect paper movement.
Heating Element 100-120 V, 50/60 Hz	RG5-1964-000CN	RG5-3459-000CN	50,000	May affect print quality and/or paper movement. Look for marks on pressure roller or upper Teflon sleeve.
220-240 V, 50 Hz	RG5-1965-000CN	RG5-3463-000CN		
Pressure Roller	RF5-1516-000CN	RF5-2362-000CN		

*The estimated toner cartridge life is based on Letter or A4 size paper with an average of 5% toner coverage and a medium density setting. Toner cartridge life can be extended further by conserving toner using the printer's EconoMode feature.

proofs. EconoMode can be set through your printer driver. See Chapter 3 for information.

Notes

Some software applications may refer to this as “draft mode.”

Refilled Toner Cartridges

While Hewlett-Packard does not prohibit the use of refilled toner cartridges during the warranty period or while under a maintenance contract, we do not recommend their use. The reasons for this are:

- Hewlett-Packard has no control or process to ensure that a refilled toner cartridge functions at the high level of reliability of a new HP LaserJet toner cartridge.
- Hewlett-Packard also cannot predict what the long-term reliability effect on the printer is from using different toner formulations found in refilled cartridges.
- Hewlett-Packard has no control over the actual print quality of a refilled toner cartridge. The print quality of HP LaserJet toner cartridges influences the customer’s perception of the printer.

Repairs resulting from the use of refilled toner cartridges are not covered under the HP warranty or maintenance contract.

Recycling Toner Cartridges

In order to reduce waste, Hewlett-Packard has adopted a recycling program for used toner cartridges. Plastics and other material are recycled. Cartridge components that do not wear out are reused. HP pays the shipping costs from the user to the recycling plant. For each cartridge returned, HP donates one U.S. dollar to be shared by the Nature Conservancy and the National Wildlife Federation. To join this recycling effort, follow the instructions inside the toner cartridge box.

Cleaning the Printer

To maintain the print quality, thoroughly clean the printer:

- Every time you change the toner cartridge.
- After printing approximately 2,500 pages.
- Whenever print quality problems occur.

Clean the outside of the printer with a lightly water-dampened cloth. Clean the inside with only a dry, lint-free cloth. Observe the warnings and cautions below.

WARNING!

Before you begin these steps, unplug the printer to avoid shock hazard.

When cleaning around the front door area, avoid touching the heating element. It may be HOT. (For heating element location, see Figure 6-14.)

Cleaning Printer Components

CAUTION

To avoid permanent damage to the toner cartridge, do not use ammonia-based cleaners on or around the printer. Do not touch the transfer roller with your fingers. Contaminants on the roller can cause print quality problems.

Table 4-2

Cleaning Printer Components

COMPONENT	CLEANING METHOD/NOTES
Outside Covers	Use a water-dampened cloth. Do not use solvents or ammonia-based cleaners.
Inside General	Use a dry, lint free cloth. Remove all dust, spilled toner, and paper particles.
Exit Roller	Use a water-dampened lint-free cloth. (For location, see Figure 6-8.)
Fuser Exit Roller	Use a water-dampened lint-free cloth. (For location, see Figure 6-18.)
Pickup Roller	Use a lint-free cloth dampened with isopropyl alcohol. (For location, see Figure 6-25.)
Pressure Roller	Use a dry lint-free cloth. (For location, see Figure 6-16.)
Transfer Roller	Use a dry, lint-free cloth. DO NOT TOUCH with your fingers. (For location, see Figure 6-30.)
Separation Pad	Use a dry lint-free cloth. (For location, see Figure 6-31.)
Delivery Assembly	Use a water-dampened lint-free cloth. (For location, see Figure 6-10.)
Static Eliminator Teeth	Use compressed air. (See Figure 4-2 on the following page for static eliminator teeth location.)

Figure 4-2

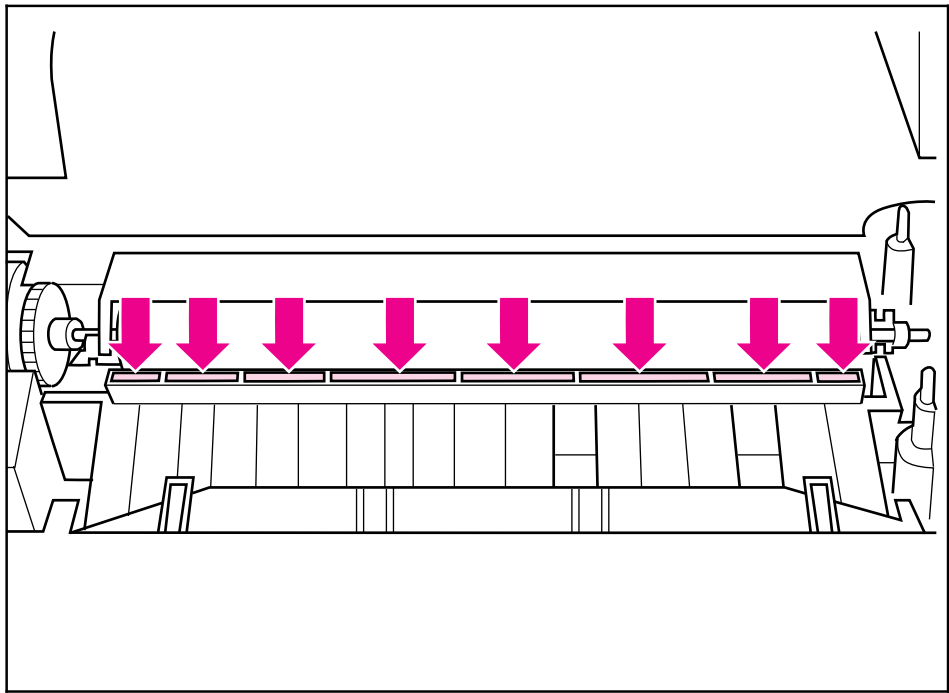

Static Eliminator Teeth (located in front of the transfer roller)

Cleaning Spilled Toner

Defective toner cartridges can develop leaks. In addition, after a paper jam has occurred, there may be some toner remaining on the rollers and guides inside the printer. The pages that print immediately after the jam may pick up this toner.

Clean spilled toner with a cloth slightly dampened in cold water. Do not touch the Transfer Roller with the damp cloth or with your fingers. Do not use a vacuum cleaner unless it is equipped with a micro-fine particle filter.

Note

If toner gets on your clothing, use cold water to remove it. Hot water sets toner stains into fabric.

Functional Overview

Contents

Basic Printer Functions	5-3
DC Controller/Power System	5-4
Print Engine Control System	5-5
Power System (on DC Controller PCA)	5-6
Formatter System	5-8
CPU	5-8
Read Only Memory (ROM)	5-8
Random Access Memory (RAM)	5-8
Parallel Interface	5-8
Control Panel	5-9
Resolution Enhancement (REt)	5-9
EconoMode	5-10
Memory Enhancement technology (MEt)	5-10
Enhanced I/O	5-11
Page Protect	5-11
PJL Overview	5-11
Image Formation System	5-12
Toner Cartridge	5-13
Step 1: Drum Cleaning	5-13
Step 2: Drum Conditioning	5-13
Step 3: Image Writing	5-13
Step 4: Image Developing	5-14
Step 5: Image Transferring	5-14
Step 6: Image Fusing	5-14
Paper Feed System	5-15
Paper Jam Detection	5-18
Basic Sequence of Operation	5-19

Basic Printer Functions

This chapter presents a generalized functional overview of the printer and the printing processes. The following printer systems are discussed:

- DC Controller System/ Power System
- Formatter System
- Image Formation System
- Paper Feed System
- Laser/Scanner System

Figure 5-1 is a generalized block diagram of the printer:

Figure 5-1

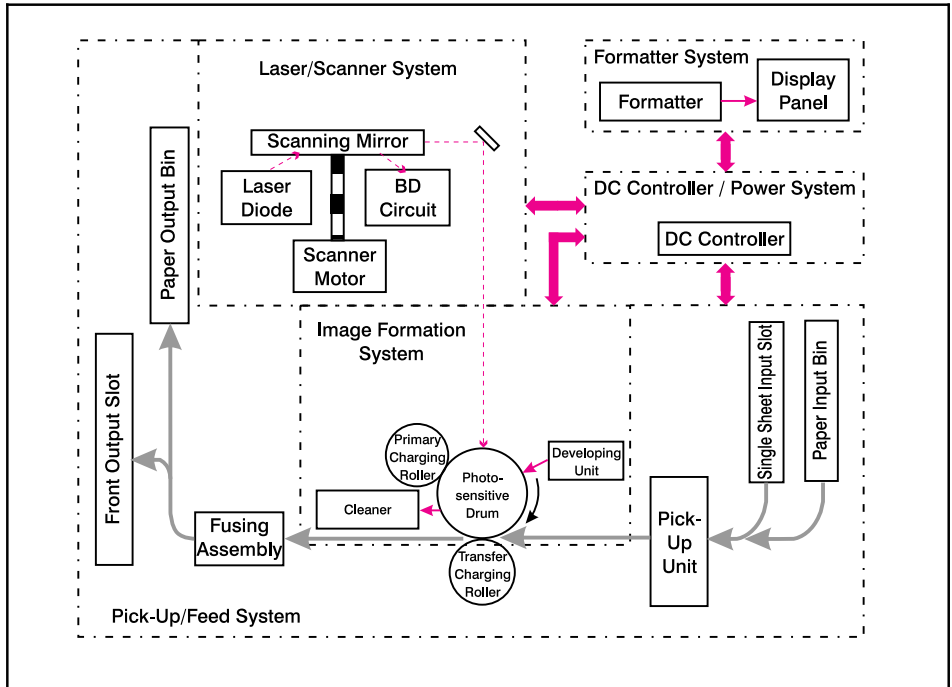

Printer Functional Block Diagram

DC Controller/Power System

The DC Controller PCA coordinates all print engine activities, drives the laser, and coordinates print data from the Formatter PCA with the image formation process. The DC Controller also includes both AC and DC power supply and distribution circuitry. The DC Controller controls the following systems and functions:

- Print Engine Control
 - Laser and Scanner Drive
 - Paper Motion Photosensors (Paper Out, Paper Registration, and Paper Exit Sensors)
 - Motor
- Power System
 - AC Power Distribution
 - DC Power Distribution
 - Overcurrent/Undervoltage Protection
 - SleepMode
 - High Voltage Power Distribution

Figure 5-2 shows the various DC controller loads.

Figure 5-2

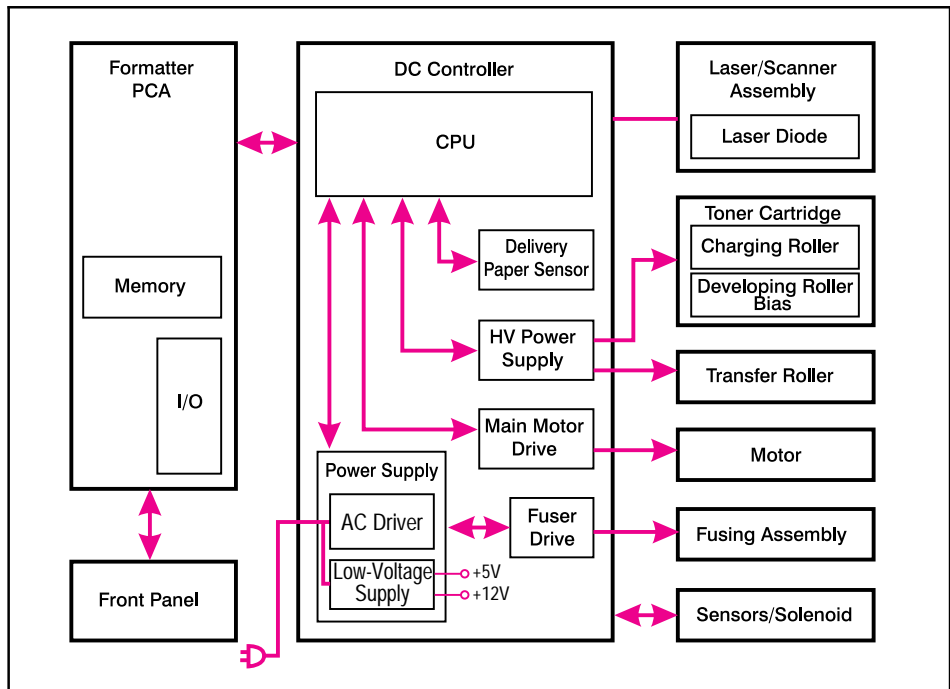

DC Controller Loads

Print Engine Control System

Laser and Scanner Drive

Based on information received from the Formatter, the DC Controller sends signals to the Laser/Scanner Assembly to modulate the laser diode ON and OFF and to drive the Laser/Scanner motor. Refer to “Image Formation System,” later in this chapter for more information.

Paper Motion Monitoring and Control

The DC Controller PCA controls paper motion by continuously monitoring the various paper sensors and coordinating the timing with the other print processes.

For a detailed explanation of paper movement, and the interaction of photosensors and solenoid with the paper movement process, refer to the section “Paper Feed System,” later in this chapter.

+12 V Shutoff Switch

The 12 volt DC power shutoff switch, Switch 101, located on the top of the printer, is activated by the printer door. The front door must be closed before the printer can resume printing.

Engine Test Switch

The Test Print, Switch 201, located on the DC Controller, is activated manually through an access hole at the front of the printer. This switch causes the print engine to perform a self-test diagnostic which bypasses the Formatter PCA and prints a full page of black vertical lines. This test is useful for troubleshooting printer problems because it isolates the print engine from the Formatter PCA. (See Chapter 7, “Troubleshooting,” to learn more about how to perform an engine test.)

Motor

The Motor is controlled by the DC Controller PCA. The Motor provides all of the printer’s paper movement.

Power System (on DC Controller PCA)

The AC, DC, and high voltage power supply circuits are all contained within the DC Controller PCA.

AC Power Distribution

The AC power circuitry supplies AC voltage whenever the power cord is connected to the AC power source. AC voltage is distributed to the DC power supply circuitry and to the AC driver circuitry, which controls AC voltage to the fusing assembly's heating element.

DC Power Distribution

The DC power distribution circuitry, located on the DC Controller PCA, distributes +5 V DC and +12 V DC as follows:

+5 V DC:	Formatter PCA Photosensors DC Controller Circuitry Laser/Beam Detect Circuitry
+12 V DC:	Motor Scanner Motor Solenoid
+12VA DC:	High Voltage Power Supply

Overcurrent/Overvoltage Protection

There are two overvoltage /overcurrent devices in this printer:

- Fuse F101 provides overcurrent protection for the fusing system circuitry. To check or replace the fuse requires the removal of the DC Controller. Fuse 102 (found only on 110V units) provides overcurrent protection to the printer DC power supply circuitry.
- In addition, the +12V DC and +5V DC power circuitry contains an overcurrent protection circuit which automatically shuts off the output voltage when an overcurrent condition occurs due to a short or abnormal voltage on the load side.

SleepMode

Instead of a power switch, the printer has a SleepMode function. After the printer has been idle for 15 minutes, it turns itself off by shifting to SleepMode. The front panel lights remain off, and the printer retains all printer settings and downloaded fonts and macros while in SleepMode.

The printer exits SleepMode and all of the lights power on when any of the following occur:

- A job is received.
- The Front Panel Button is pressed.
- The printer front door is opened.

Note

The printer will not enter SleepMode if there is a printer error.

High Voltage Power Distribution

The High Voltage Power Supply PCA applies an overlap of DC and AC voltage to the primary charging roller and the developing roller. This circuit also applies a positive or negative DC voltage to the transfer charging roller according to the instructions from the CPU on the DC Controller PCA.

This circuit also controls the image density by changing the primary AC voltage and the developing AC bias according to the setting of the print density dial.

High voltage is disabled when the printer's EP Door is open (i.e., switch SW101 is open).

Formatter System

The Formatter PCA is responsible for the following:

- Receiving and processing print data from the printer interface.
- Monitoring Front Panel Button and relaying printer status information.
- Developing and coordinating data placement and timing with the print engine.
- Storing font information.
- Communicating with the host computer through the Bi-Directional Interface.

The Formatter PCA receives print data from the Bi-Tronics Interface and converts it into a dot image. The DC Controller synchronizes the Image Formation System with the Paper Feed System and signals the Formatter to send the print image data. The Formatter sends the print image data (dots) in the form of a VIDEO signal and the printing process begins.

The Formatter PCA also provides mounting locations for additional memory.

CPU

The Formatter PCA incorporates a Motorola 68030 custom-built microprocessor operating at 24 MHz.

Read Only Memory (ROM)

Besides storing microprocessor control programs, the ROM stores dot patterns of internal character sets (fonts).

Random Access Memory (RAM)

The RAM stores printing and downloaded font information received from the host system and temporarily stores a full page of print image data before the data is sent to the print engine. (See “Page Protect” later in this chapter.) Memory capacity can be increased by adding a DRAM memory card to the Formatter PCA. Note that adding memory may also increase print speed when printing complex graphics.

Parallel Interface

The Formatter PCA receives incoming data through its Bi-Tronics interface. The Bi-Tronics I/O provides high speed and two-way communication between the printer and the host, allowing the user to change printer settings and monitor printer status from the host computer. This interface is IEEE-1284 compliant.

Control Panel

Status LED Lights

The Formatter uses three LEDs mounted under the printer cover to communicate printer status to the user. Refer to “Using the Control Panel” in Chapter 3 and “Printer Error Troubleshooting” in Chapter 7 for more information on the lights.

Front Panel Button

The Formatter PCA is connected to a microswitch located on the control panel PCA. The single button is used for such functions as self test, reset, and to display error codes. Refer to “Using the Control Panel” in Chapter 3 for more information on the Front Panel Button.

Resolution Enhancement (REt)

The Formatter PCA contains circuitry for Resolution Enhancement technology (REt), which modifies the standard video dot data on its way to the DC Controller to produce “smoothed” black-to-white boundaries. REt is user-adjustable from some software applications. Available settings are On or Off.

EconoMode

The EconoMode setting uses approximately 50% less toner than standard mode printing by reducing the dot density. However, EconoMode does not extend toner cartridge component life. EconoMode, which can also be thought of as “draft mode,” is user-selectable through some software applications. The default setting is Off.

Figure 5-3

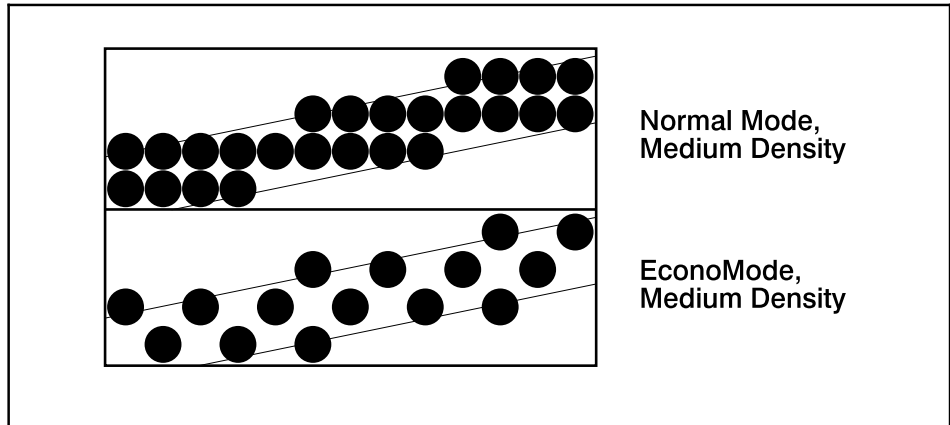

EconoMode vs Normal Mode

Note

EconoMode does not affect print speed or memory usage.

Memory Enhancement technology (MEt)

The Hewlett-Packard Memory Enhancement technology (MEt) effectively doubles the standard memory through a variety of font and data compression methods. MEt is only available in PCL mode and is not customer selectable. When using the host-based driver, your PC handles memory management.

Enhanced I/O

The Enhanced I/O feature allows printer memory to be used for storing data received from the host computer. When Enhanced I/O is enabled, you can send more data to your printer in shorter amounts of time, which allows you to return to your application sooner. Enhanced I/O has the following options:

- **Auto**—allows the printer to use Enhanced I/O memory allocation to increase the speed of data transfer from the host computer to the printer, if necessary.
- **Off**—uses the minimum amount of printer memory for storing data sent from the host computer.

Enhanced I/O is only available in PCL mode. When using the host-based driver, your PC handles memory management.

Page Protect

Page complexity (rules, complex graphics, or dense text) may exceed the printer's ability to create the page image fast enough to keep pace with the Image Formation process. If Page Protect is disabled and a page is too complex, the page may print in parts (for example, the top half on one page and the bottom half on the next page). Some print data loss is likely in these instances, and the printer will display an error message.

Page Protect allows the Formatter to create the entire page image in page buffer memory before physically moving the paper through the printer. This process ensures that the entire page will be printed. Page Protect applies only to PCL printing. The default setting is Auto.

PJL Overview

Printer Job Language (PJL) is an integral part of configuration, in addition to the standard Printer Command Language (PCL). With standard Centronics cabling, PJL allows the printer to perform functions such as:

- **Two-way communication** with the host computer through a Bi-directional Parallel connection. The printer can tell the host such things as the control panel status.
- **Isolation of print environment settings** from one print job to the next. For example, if a print job is sent to the printer in landscape mode, the subsequent print jobs print in landscape only if they are formatted for landscape printing.

Image Formation System

Laser printing requires the interaction of several different technologies (such as electronics, optics, and electrophotographics) to provide a printed page. Each process functions independently and must be coordinated with the other printer processes. Image formation consists of six processes:

- Step 1. Drum Cleaning
- Step 2. Drum Conditioning
- Step 3. Image Writing
- Step 4. Image Developing
- Step 5. Image Transferring
- Step 6. Image Fusing

Figure 5-4

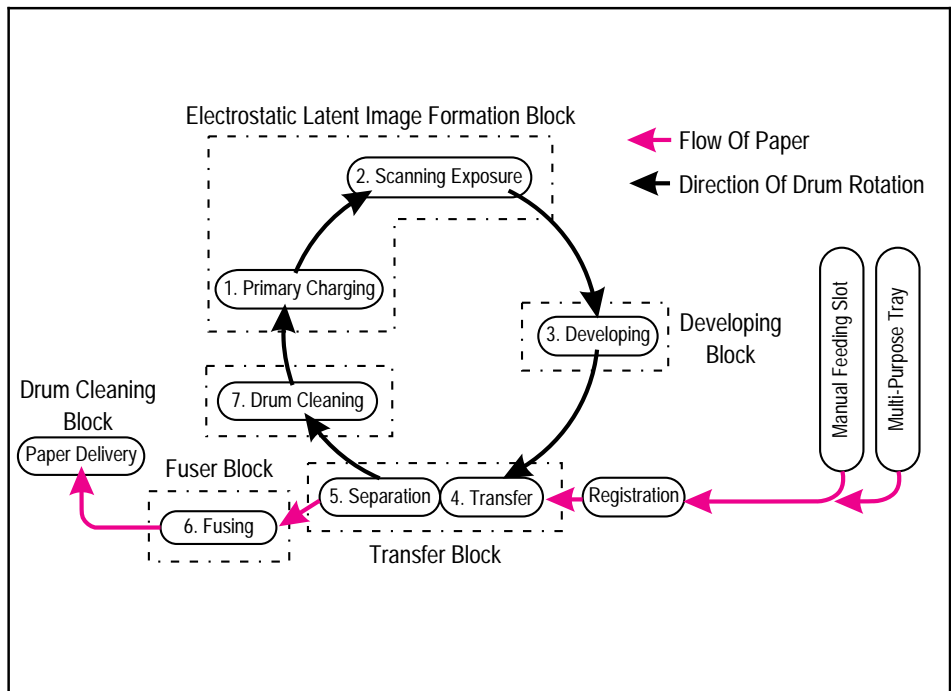

Image Formation Block Diagram

Toner Cartridge

As the “heart” of the Image Formation System, the toner cartridge houses the cleaning, conditioning, and developing steps of the process. The toner cartridge contains the photosensitive drum, primary charging roller, developing station, toner cavity, and cleaning station. Including these components, which wear, degrade, or are consumed in the replaceable toner cartridge, eliminates the need for a service call when replacement is required. The special photosensitive properties of the drum allow an image to be formed on the drum surface and then transferred to paper.

CAUTION

The printer’s toner cartridge does not include a light-blocking shutter. Be careful to avoid exposing the drum to light, which can permanently damage the drum. Protect the cartridge whenever removing it from the printer.

Step 1: Drum Cleaning

The cleaning blade is in contact with the surface of the drum at all times. As the drum rotates during printing, excess toner is wiped off and stored in the waste toner receptacle.

Step 2: Drum Conditioning

After the drum is physically cleaned, it must be conditioned. This process consists of applying a uniform negative charge on the surface of the drum with the primary charging roller, located in the toner cartridge. The primary charging roller is coated with conductive rubber. An AC bias is applied to the roller to erase any residual charges from any previous image. In addition, a negative DC bias is applied by the charging roller to create a uniform negative potential on the drum surface. The amount of DC voltage is modified by the print density setting.

Step 3: Image Writing

During the writing process, a modulated laser diode projects the beam onto a rotating scanning mirror. As the mirror rotates, the beam reflects off the mirror, first through a set of focusing lenses, off a mirror, and finally through a slot in the top of the toner cartridge, and onto the photosensitive drum. The beam sweeps the drum from left to right, discharging the negative potential wherever the beam strikes the surface. This creates a latent electrostatic image, which later is developed into a visible image.

Because the beam is sweeping the entire length of the drum and the drum is rotating, the entire surface area of the drum can be covered. At the end of each sweep, the beam strikes the beam detect lens, generating the Beam Detect Signal (BD). The BD signal is sent to the DC Controller, where it is converted to an electrical signal used to synchronize the output of the next scan line of data.

Step 4: Image Developing

At this stage of the process, the latent electrostatic image is present on the drum. The toner particles obtain a negative surface charge by rubbing against the developing cylinder which is connected to a negative DC supply. The negatively charged toner is attracted to the discharged (exposed, grounded) areas of the drum, and repelled from the negatively charged (non-exposed) areas.

Step 5: Image Transferring

During the transferring process, the toner image on the drum surface is transferred to the paper. A positive charge applied to the back of the paper by the transfer roller causes the negatively charged toner on the drum surface to be attracted to the paper. After separation, the drum is cleaned and conditioned for the next image.

Step 6: Image Fusing

During the fusing process, the toner is fused into the paper by heat and pressure to produce a permanent image. The paper passes between a heated fusing element and a soft pressure roller. This melts the toner and presses it into the paper.

Paper Feed System

Both the Paper Input Bin and the Single Sheet Input Slot merge into one, main input area. Paper placed in either of these areas enables the Paper Out Sensor (sensor 202), which informs the DC Controller that paper is present.

When the printer receives a print job and is ready to print, the DC Controller enables the Laser/Scanner Assembly and the Motor. Paper motion begins when the DC Controller energizes solenoid SL1. This causes the paper pick up roller to rotate once. Two actions occur as a result of this rotation. First, the paper kick plate pushes the paper against the pick-up roller. Second, the pick-up roller grabs the top sheet and advances it to the Feed Assembly drive rollers. To ensure that only one sheet is fed, a main separation pad, along with two subpads, hold the remainder of the stack in place.

The feed assembly drive rollers advance the paper to the Paper Registration photosensor (PS203). This sensor informs the DC Controller of the exact location of the paper's leading edge, so that the image being written on the photosensitive drum can be precisely positioned on the page. The feed assembly drive rollers then advance the paper to the transfer area where the toner image on the photosensitive drum is transferred to paper.

After the image is transferred, the paper enters the fusing assembly where heat from the fuser and pressure from the Pressure Roller permanently bond the toner image to paper. The Paper Exit Sensor (PS201) determines that paper has successfully moved out of the fusing area. The fusing assembly exit rollers deliver paper to either the Output Paper Bin or the Front Output slot, depending upon the position of the Face-up/Face-down lever.

Figure 5-5 shows a simplified paper path and the locations of the photosensors and rollers.

Figure 5-5

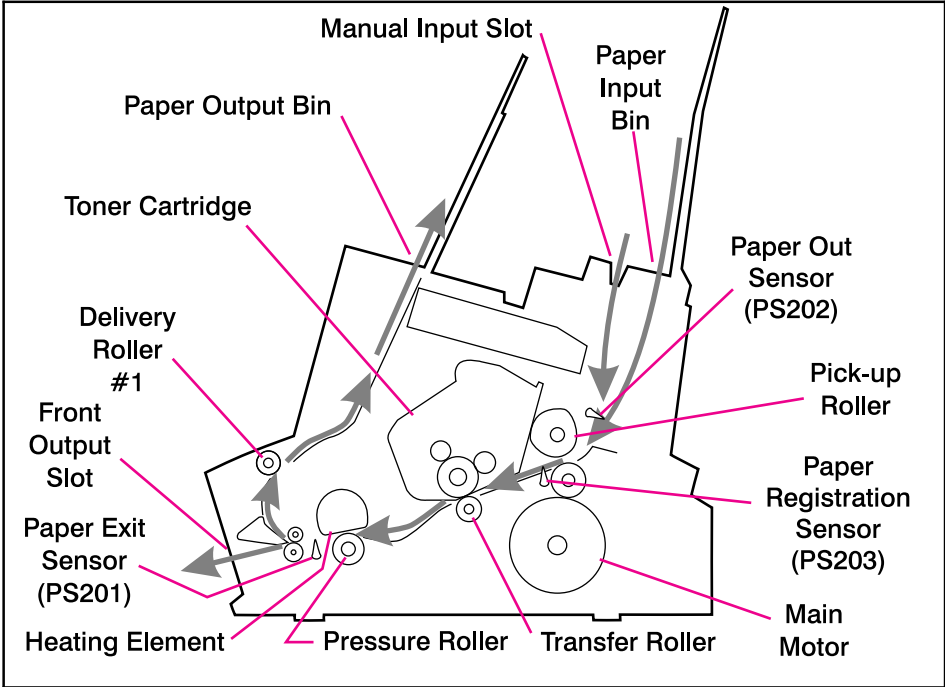

Simplified Paper Path

Figure 5-6 shows the locations of the photosensors, switches, solenoid, and other important printer elements. Table 5-1 describes the function of each photosensor and the solenoid.

Figure 5-6

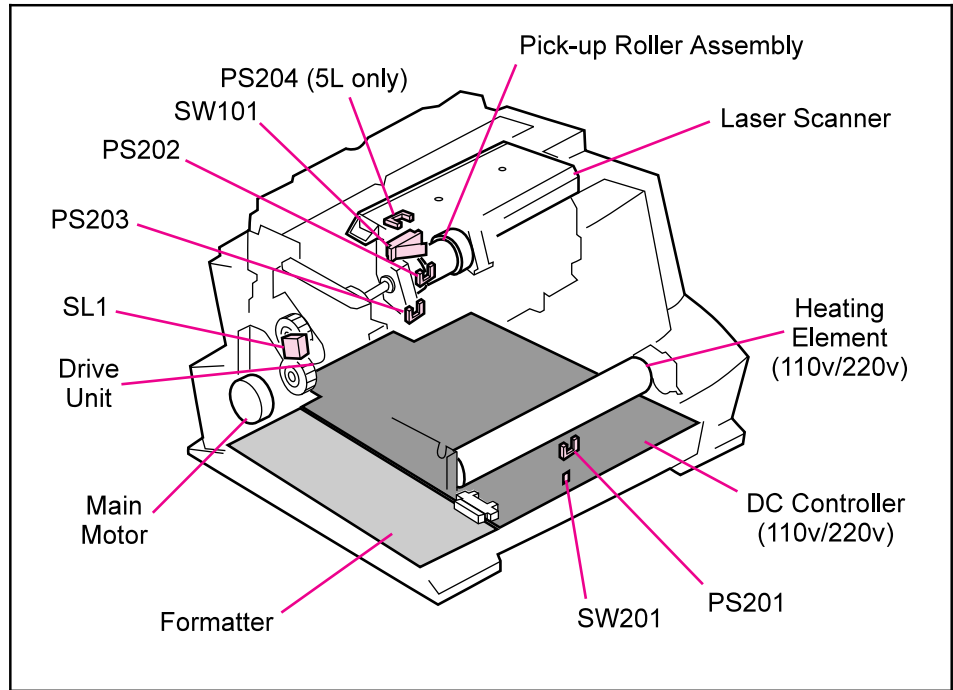

Solenoid and Sensors

Table 5-1

Solenoid and Photosensors

No.	Name	Description
SL1	Paper Pick-up Solenoid	Enables the Paper Pickup Roller.
PS201	Paper Exit Sensor	Senses when paper has successfully moved out of the fusing area and the next sheet of paper can be fed.
PS202	Paper Out Sensor	Senses no paper in either the Paper Input Bin or Manual Input Slot. If this sensor does not sense paper in the Input Paper Bin or the Single-Sheet Input Slot, the formatter displays the paper-out indication on the front panel. Paper must be reloaded before printing can resume.
PS203	Paper Registration Sensor	Detects the leading and trailing edges of the paper. Synchronizes the photosensitive drum and the top of the paper.
PS204	Door Open/Cartridge Sensor (HP LaserJet 5L only) In the HP LaserJet 6L, SW101 performs the functions of 5L's PS204.	Detects whether printer door is open and cartridge is in place. If the door is open or the cartridge is not in place, the control panel LEDs will display an error message. Printing cannot continue until the door is closed and the cartridge is in proper position.

Paper Jam Detection

The Paper Out Sensor (PS202), Paper Registration Sensor (PS203), and the Paper Exit Sensor (PS201) detect when paper is moving through the printer. (See Figure 5-5 for roller and sensor locations.) If a paper jam is detected, the DC Controller immediately stops the printing process and causes a paper jam indication on the front panel.

A paper jam can be detected under any of the following conditions:

- **Power-On Jams.** Paper is present under either PS201 or PS203 at power-on.
- **Pickup Jams.** Paper does not reach and clear photosensor PS203 within a specified period of time. The time period begins when the Paper Pickup Solenoid (SL1) is energized.
- **Delay Jams.** Paper does not reach or clear a specific photosensor within a specified period of time.

Basic Sequence of Operation

The Formatter PCA and the DC Controller PCA share information during printer operation. The DC Controller-to-Formatter Connector (J201) forms a link which operates as a serial data bus. This allows printer status, command information, and dot-image data to be passed between the two PCAs. Figure 5-7 shows the general timing of the printer events. The following events take place during normal printer operation:

Table 5-2

Printer Timing

Period	Timing	Purpose
WAIT	From when the paper is inserted to the end of Main Motor initial rotation.	Clear the drum surface potential and clean the Transfer Roller.
STBY (standby)	From the end of the WAIT or the LSTR period until the input of the PRNT signal from the Formatter. Or from the end of the LSTR period until power OFF.	Maintain the printer in ready state.
INTR (initial rotation)	From the input of the PRNT signal from the Formatter until the laser diode intensity has been stabilized.	Stabilize the photosensitive drum sensitivity in preparation for printing. Also clean the Transfer Roller.
PRNT	From the end of initial rotation until the Scanner Motor stops.	Form images on the photosensitive drum based on the /VDO signal from the Formatter and transfer the image to paper.
LSTR (last rotation)	From the primary voltage (DC) OFF until the Main Motor stops. If another PRNT signal is sent from the Formatter, the printer returns to the INTR period. If not, it returns to the STBY period.	Deliver the last sheet of paper. Also clean the Transfer Roller.

Refer to Timing Diagram on the next page

Figure 5-7

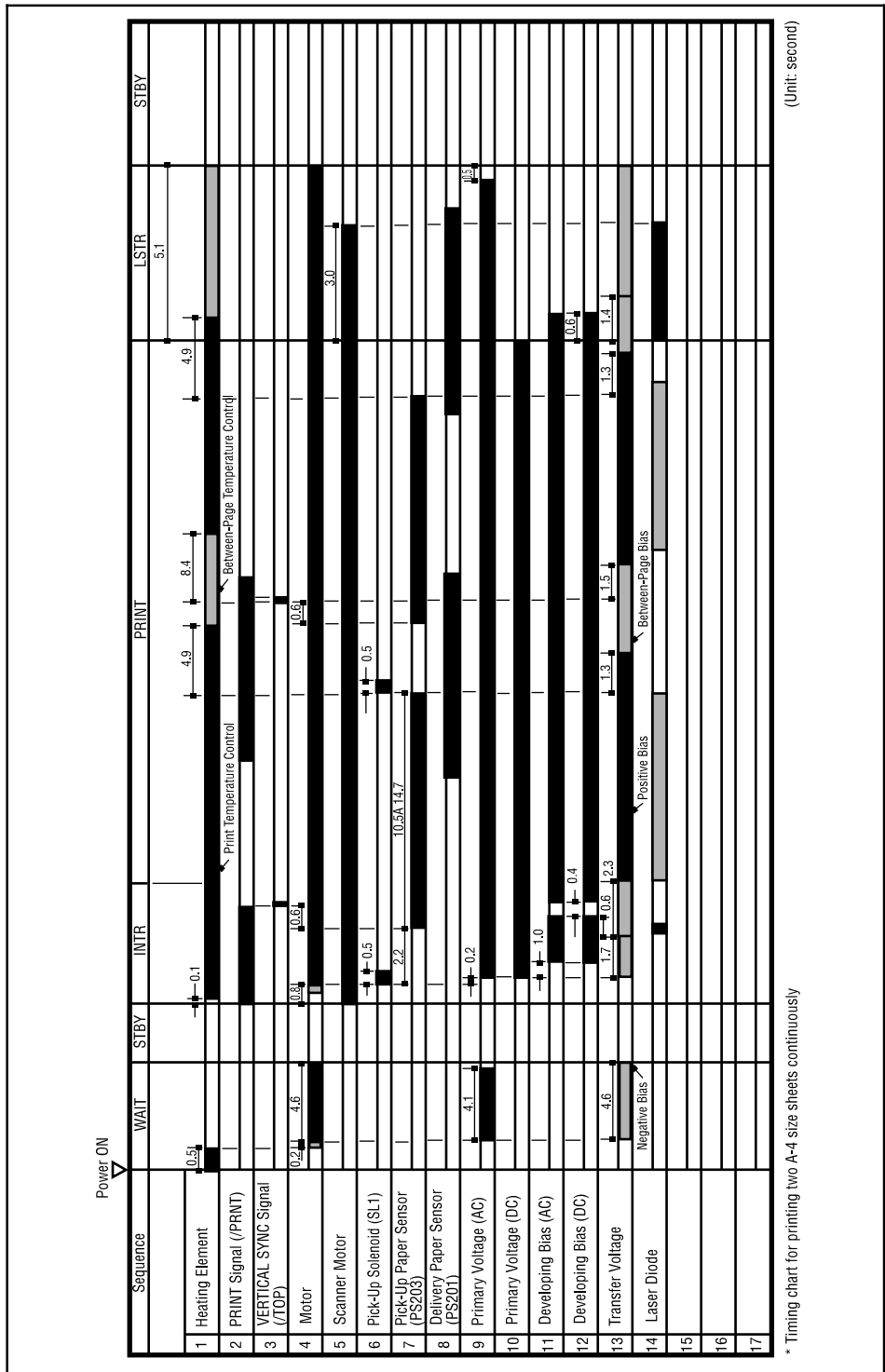

(Unit: second)

* Timing chart for printing two A-4 size sheets continuously

General Timing Diagram - HP LaserJet 5L

Figure 5-8

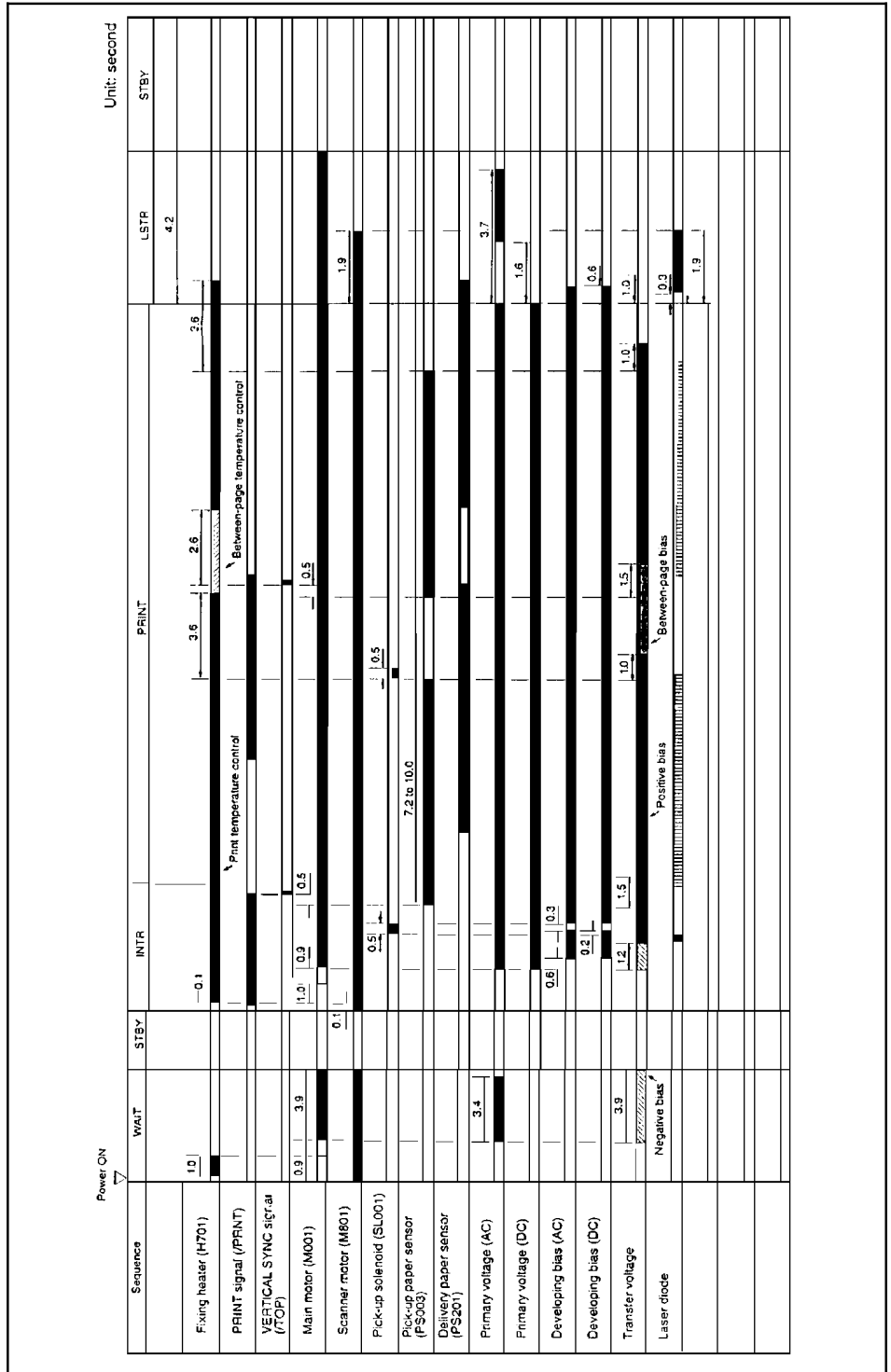

General Timing Diagram - HP LaserJet 6L

Removal and Replacement

Contents

Removal and Replacement Strategy	6-3
Required Tools	6-4
Installing Memory Cards (DRAM)	6-5
Covers and Doors	6-6
Back Cover	6-6
EP Door Assembly	6-8
Memory Door	6-9
Main Cover and Paper Input Assembly	6-10
Internal Assemblies	6-11
Control Panel	6-11
Exit Roller Assembly	6-12
Delivery Assembly	6-13
Fuser Pressure Plate	6-15
Heating Element	6-17
Pressure Roller	6-20
Face-Up/Face-Down Lever	6-21
Fuser Exit Roller Assembly	6-22
Paper Exit Sensor Flag	6-23
Top Assemblies	6-24
Laser/Scanner Assembly	6-24
Solenoid	6-25
Pickup Roller Assembly	6-27
Paper Feed Frame	6-30
Transfer Roller Guide & Transfer Roller	6-34
Kick Plate	6-35
Separation Pad	6-37
Subpads	6-38
Feed Assembly	6-39
Bottom Assemblies	6-42
Memory Door Guide	6-42
Motor	6-43
DC Controller	6-44
Formatter Board	6-47

Removal and Replacement Strategy

This chapter documents removal and replacement of Field Replaceable Units (FRUs) only. Exchange assemblies should be sent to SMO for repair.

Replacement is generally the reverse of removal. Occasionally, notes are included to provide direction for difficult or critical replacement procedures.

WARNING!

Unplug the power cord from the power outlet before attempting to service the printer. If this warning is not followed, severe injury may result.

Never operate or service the printer with the protective cover removed from the Laser/Scanner Assembly. The reflected beam, although invisible, can damage your eyes.

The sheet metal edges of this printer can be sharp! Exercise caution when working with the printer.

Caution

The printer contains parts that are electrostatic discharge (ESD) sensitive. Always service printers at an ESD-protected workstation.

To install a self-tapping screw, first turn it counter-clockwise to align it with the existing thread pattern, then carefully turn clockwise to tighten. Do not overtighten. If a self-tapping screw-hole becomes stripped, repair the screw-hole or replace the affected assembly.

Note

Always remove the toner cartridge before removing or replacing parts.

Required Tools

- #2 Phillips screwdriver with a magnetic tip
- 5.5 mm hexhead nutdriver
- small flathead screwdriver
- needlenose pliers

Caution

A Posidriv screwdriver will damage the printer's screw heads. Use Phillips only.

Figure 6-1 shows the difference between a Phillips and a Posidriv screwdriver. Note that a Phillips tip has more beveled surfaces.

Figure 6-1

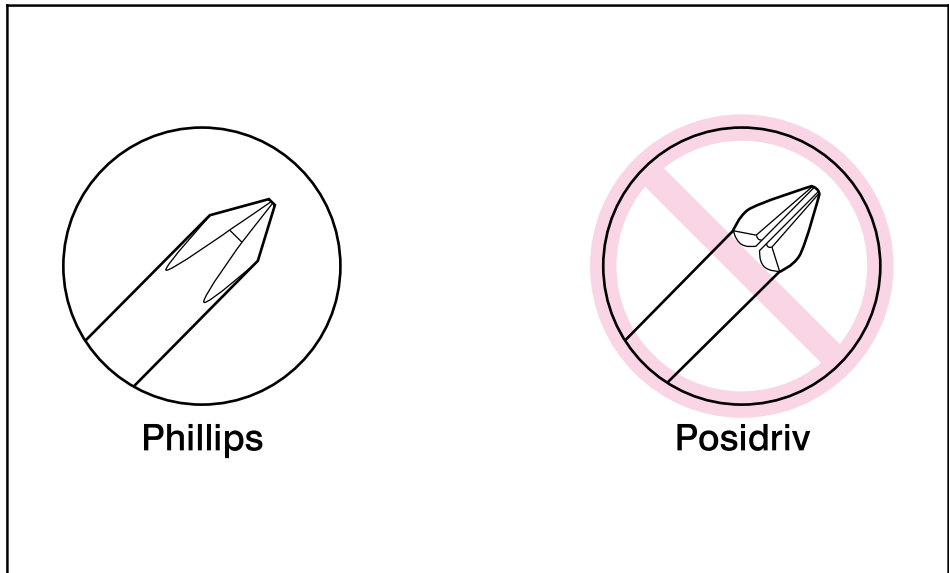

Phillips and Posidriv screwdrivers

Installing Memory Cards (DRAM)

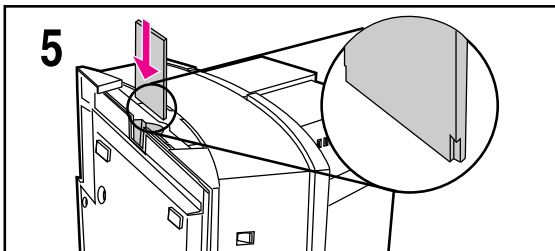
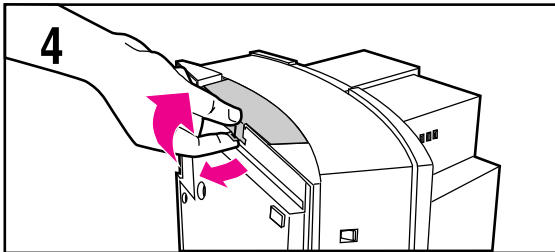
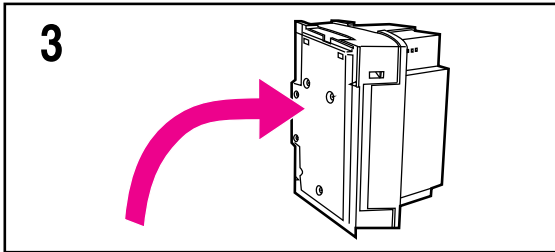
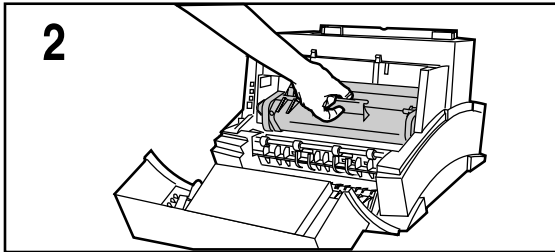
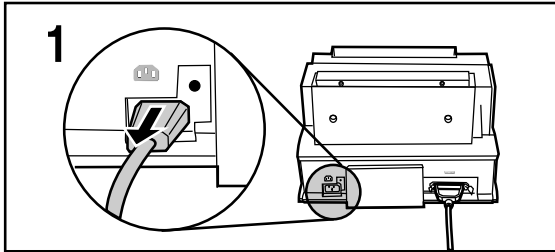

- 1 Unplug the power cord from the printer. You should not install a memory card while the printer is in SleepMode.
- 2 Open the Printer Door, remove the toner cartridge, and close the Printer Door. Protect the toner cartridge from light while you are working on the printer.
- 3 Remove any paper in the paper tray. Gently tip the printer onto its side so that the memory cover is on top as shown in Figure 3.
- 4 Remove the Memory Expansion Cover by carefully pulling the tab out and away from the printer in a gentle rocking motion.
- 5 Align the memory card with the corner notch so it is positioned as in Figure 4. Push it firmly into the printer.

Replace the Memory Expansion Cover, set the printer upright, reinstall the toner cartridge, reinsert paper, and reconnect to the power source.

Print a self-test page (see Chapter 3) to check that the printer recognizes the additional memory you have added. Your Total Memory in the "Printer Information" section will show the new MB total.

1 MByte card 2 MByte total

2 MByte card 3 MByte total

4 MByte card 5 MByte total

8 MByte card 9 MByte total

Covers and Doors

Back Cover

- 1 Unplug the power cord and remove the parallel cable from the back of the printer.
- 2 Remove the toner cartridge.
- 3 Lift the Input Extender assembly.

Caution

You must lift the Input Extender when the covers are removed or it will break. After you have removed the covers, leave the Input Extender in this lifted position for ease of replacement.

- 4 Remove the (3) screws (Figure 6-2, callout 1).

Figure 6-2

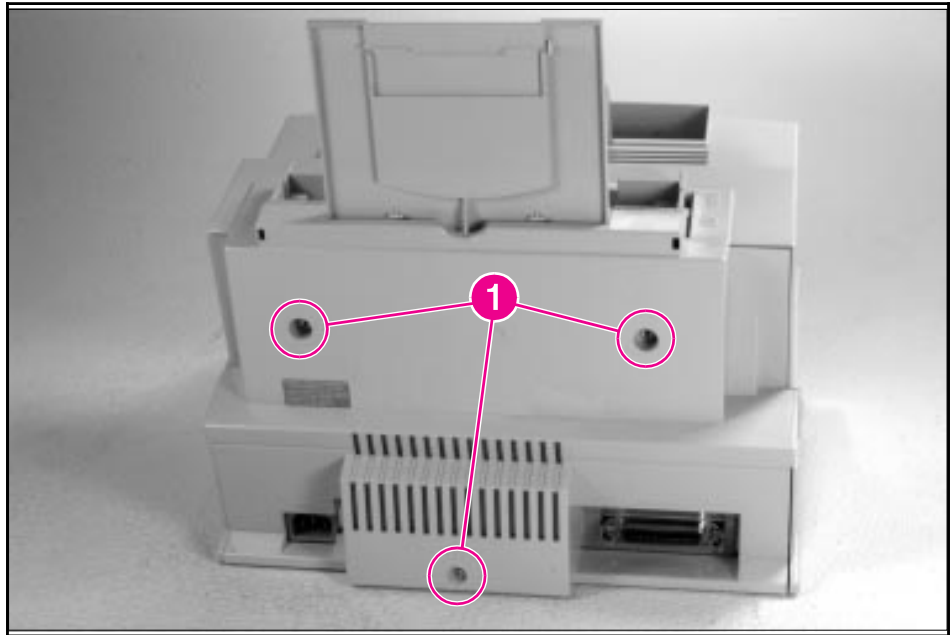

Back Cover Removal (1 of 2)

- 5 Separate the rear panel from the main cover, pulling the lower corners away from the printer first. Then, insert the small flathead screwdriver into the openings at the top to pop the upper corners (Figure 6-3, callout 1).
- 6 Remove the cover by grabbing it on both sides and pulling it straight back with a firm pull (Figure 6-3, callout 2).

Figure 6-3

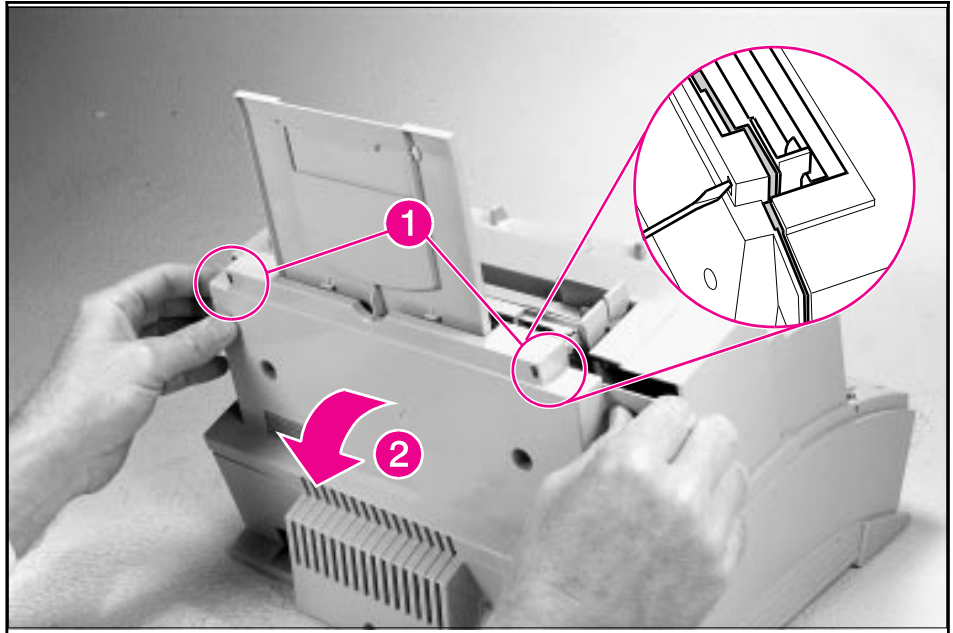

Back Cover Removal (2 of 2)

To reinstall

Make certain the Input Extender is up.

EP Door Assembly

- 1 Unplug the power cord and remove the parallel cable from the back of the printer.
- 2 Open the EP door.
- 3 Remove the toner cartridge.
- 4 Along the door hinge, there is a flex point. Firmly press the left tab inward to release it. The right tab will fall out easily (Figure 6-4).

Figure 6-4

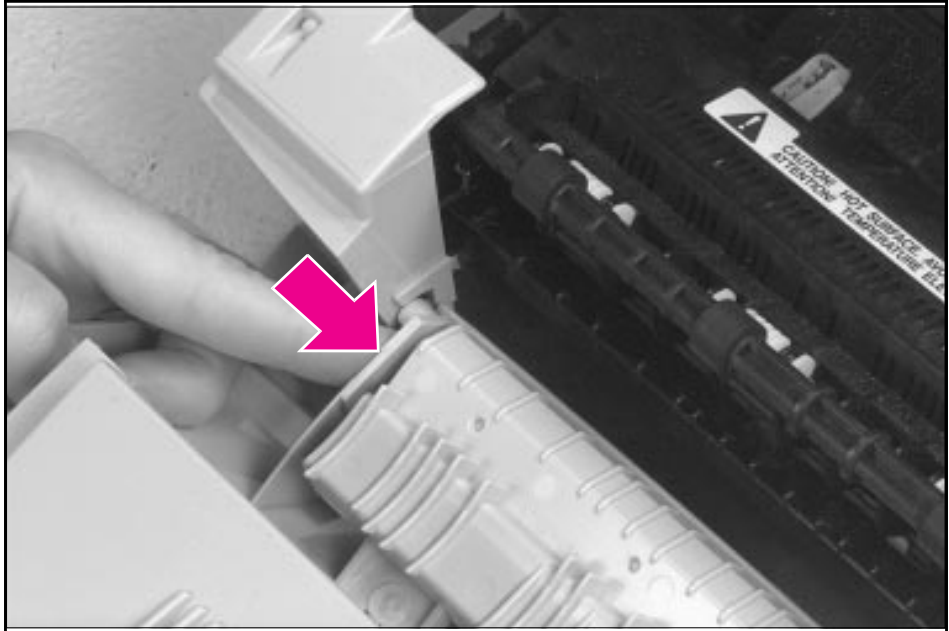

EP Door Assembly Removal

Memory Door

- 1 Unplug the power cord and remove the parallel cable from the back of the printer.
- 2 Remove the toner cartridge.
- 3 Gently tip the printer onto its side so that the Control Panel is on top.
- 4 Carefully pull the door tab out (Figure 6-5, callout 1) and away from the printer in a gentle rocking motion (Figure 6-5, callout 2).

Figure 6-5

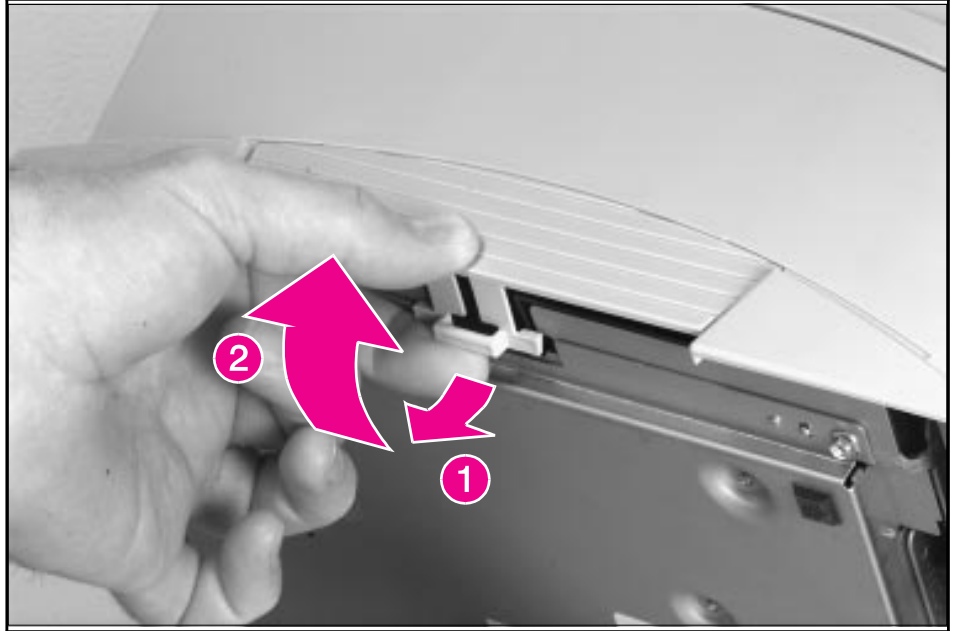

Memory Door Removal

Main Cover and Paper Input Assembly

- 1 Remove the toner cartridge.
- 2 Remove memory door.

Caution

Remove the memory door first. The door will break if you remove the Main Cover without removing the memory door.

- 3 Remove the EP Door Assembly.
- 4 Remove the Back Cover.
- 5 Remove the (2) screws from the top of the printer (Figure 6-6, callout 1).
- 6 Grasp the two lower, front corners of the printer and pull gently outward to release the front of the Main Cover.
- 7 Lift the cover straight off.
- 8 Remove the Paper Input Assembly (Figure 6-6, callout 2) by rotating it forward and lifting it out with firm pressure.

Figure 6-6

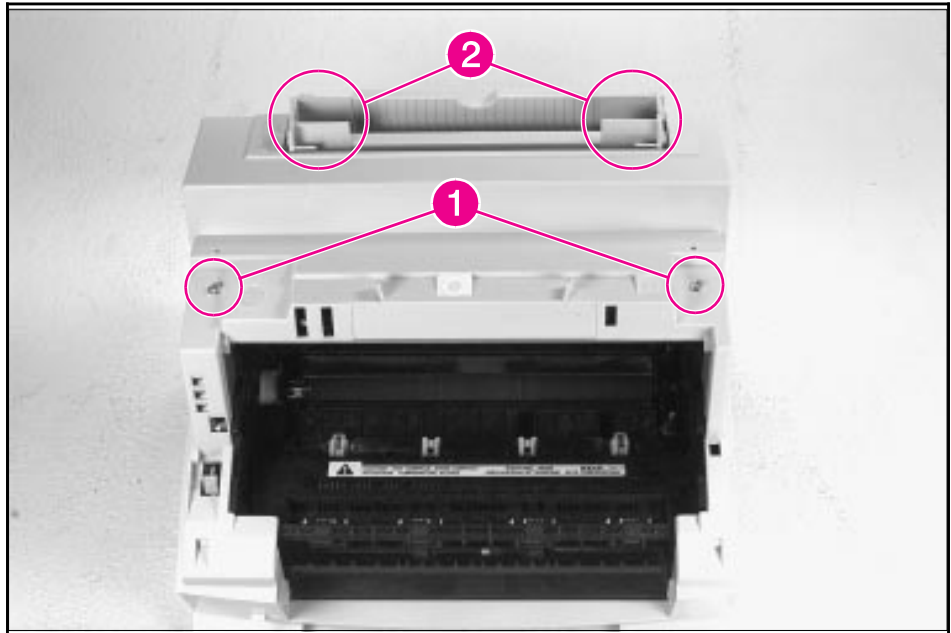

Main Cover and Paper Input Assembly Removal

Note

When replacing the Paper Input Assembly, make certain that the mylar sheet is positioned between the Input Feed Roller and Separation Pad and that the sheet is not folded or bent.

Internal Assemblies

Control Panel

- 1 Remove the Printer Covers.
- 2 Use the needlenose pliers to release the Control Panel connector (Figure 6-7, callout 1).
- 3 Press the tab on the top of the Control Panel downward (Figure 6-7, callout 2). The Control Panel will pop out of the printer chassis.
- 4 Lift the Control Panel out.

Figure 6-7

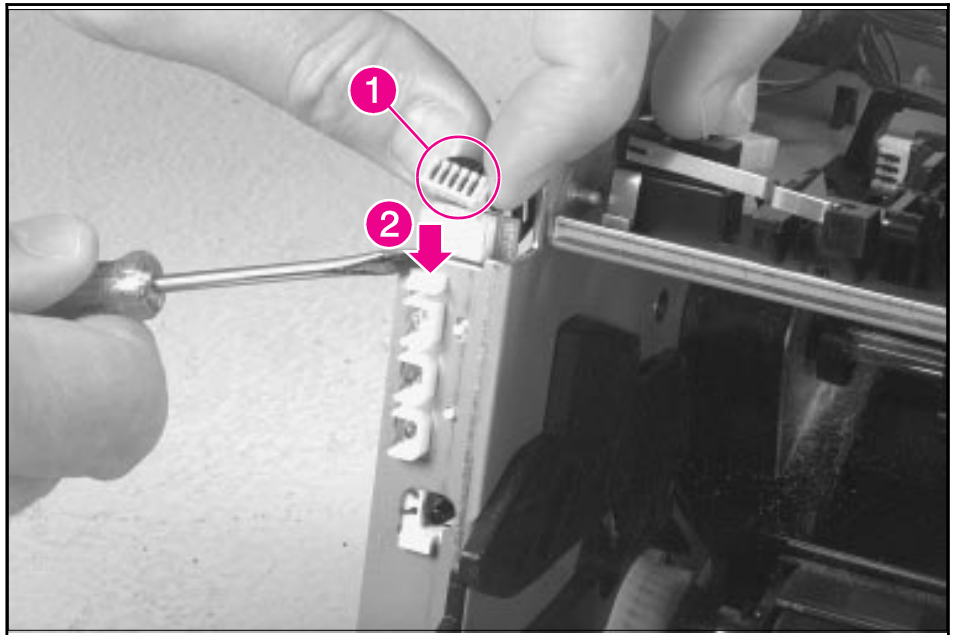

Control Panel Removal

Exit Roller Assembly

- 1 Remove Printer Covers.
- 2 Grasp both tabs at the lower ends of the Exit Roller bushings and pull inward. This will release the tabs from the printer chassis (Figure 6-8, callout 1).
- 3 Rotate the tabs 90 degrees, clear of the printer chassis (Figure 6-8, callout 2).
- 4 Lift the roller out.

Figure 6-8

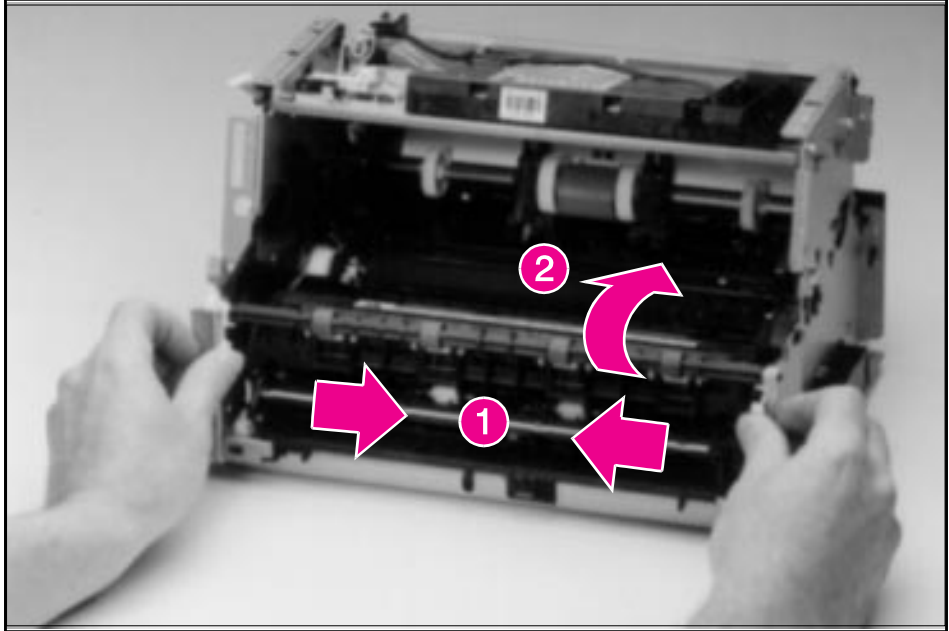

Exit Roller Removal

To reinstall

The end of the Exit Roller that has a gear attached must fit into the gear train. It is possible to reinstall the Exit Roller so that the gear end is on the opposite side of the printer; this placement would cause paper path problems.

Delivery Assembly

- 1 Remove the Printer Covers and Exit Roller Assembly.
- 2 Remove the EP Right-Hand assembly by pressing the tab in (Figure 6-9, callout 1) and sliding the assembly toward the front of the printer (Figure 6-9, callout 2).

Note

The EP Right-Hand assembly must be removed to access any fuser components.

Figure 6-9

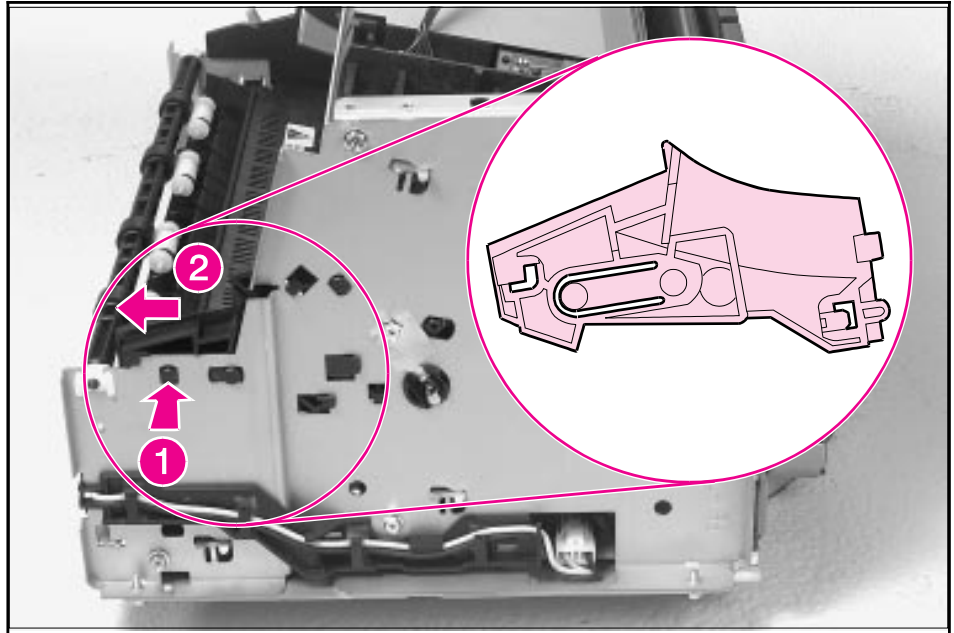

Delivery Assembly Removal (1 of 2)

- 3 Use the magnetic screwdriver to remove the (2) screws (Figure 6-10, callout 1). Once the screws have been removed, rotate the rear of the Delivery Assembly up and forward and lift it out of the printer.

Figure 6-10

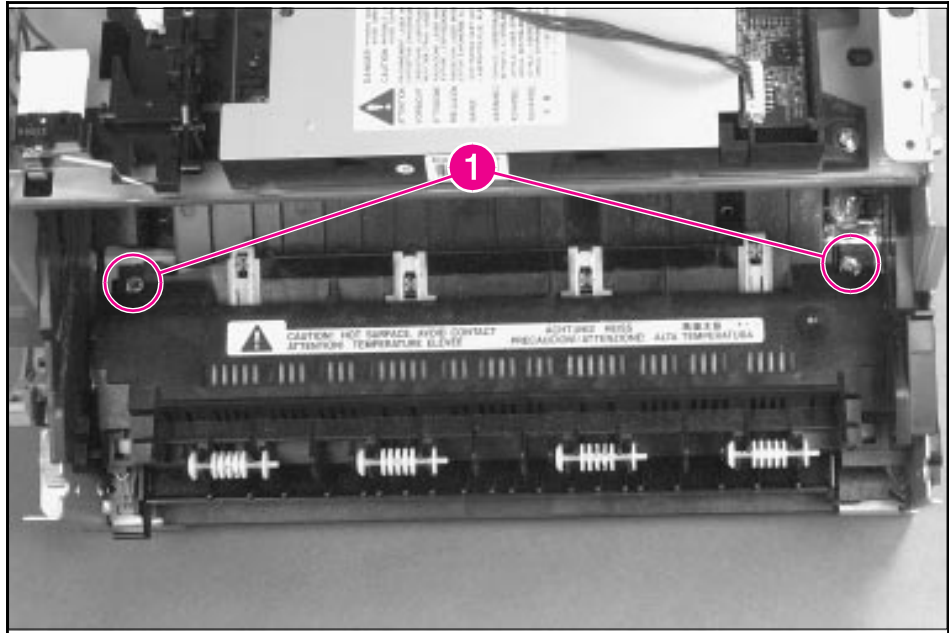

Delivery Assembly Removal (2 of 2)

Note

Upon reinstallation, the tabs on the front end of the Delivery Assembly must fit under the sheet metal fuser plate below to correctly reseat the Delivery Assembly.

Fuser Pressure Plate

- 1 Remove Printer Covers and Delivery Assembly (Figures 6-9 and 6-10).
- 2 Remove the (2) screws (Figure 6-11, callout 1).
- 3 Press the Fuser Plate retainer clips out to release the Pressure Plate (Figure 6-11, callout 2).
- 4 Rotate the plate around and toward the back and lift up to remove it (Figure 6-11, callout 3).

Figure 6-11

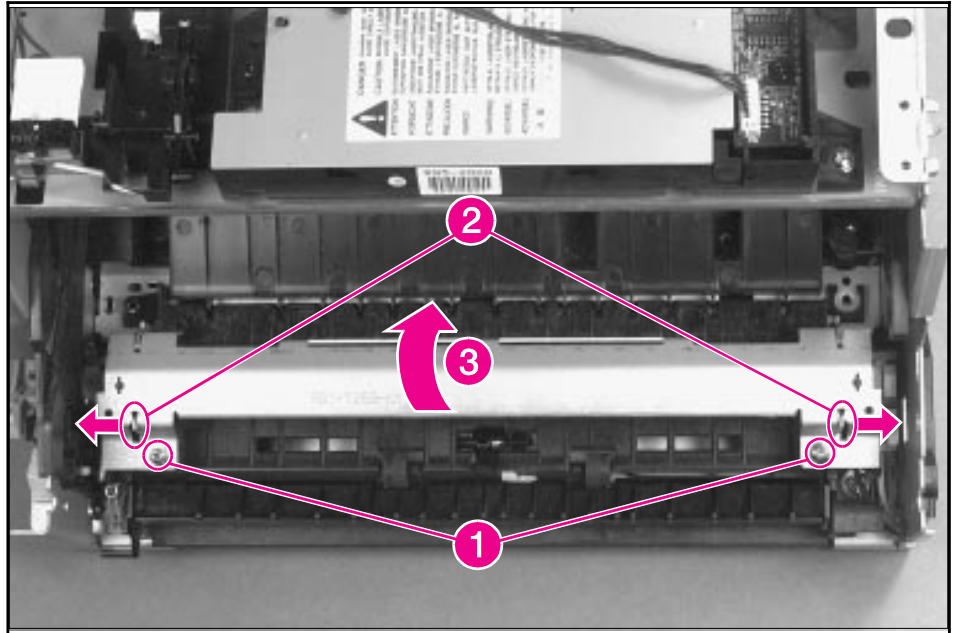

Fuser Pressure Plate Removal

To reinstall:

The Fuser Pressure Plate is kept in place by four locking mechanisms in each corner. Place the rear slits in the plate over the rear brackets that hold the Fusing Assembly (Figure 6-12, callout 1). Lower the plate over the retaining clips, pressing on both sides of the Fuser Pressure Plate (Figure 6-12, callout, 2). It is important that the spring is placed over the positioning pin (callout 3) because inadequate pressure will cause fusing problems. Replace the screws.

Figure 6-12

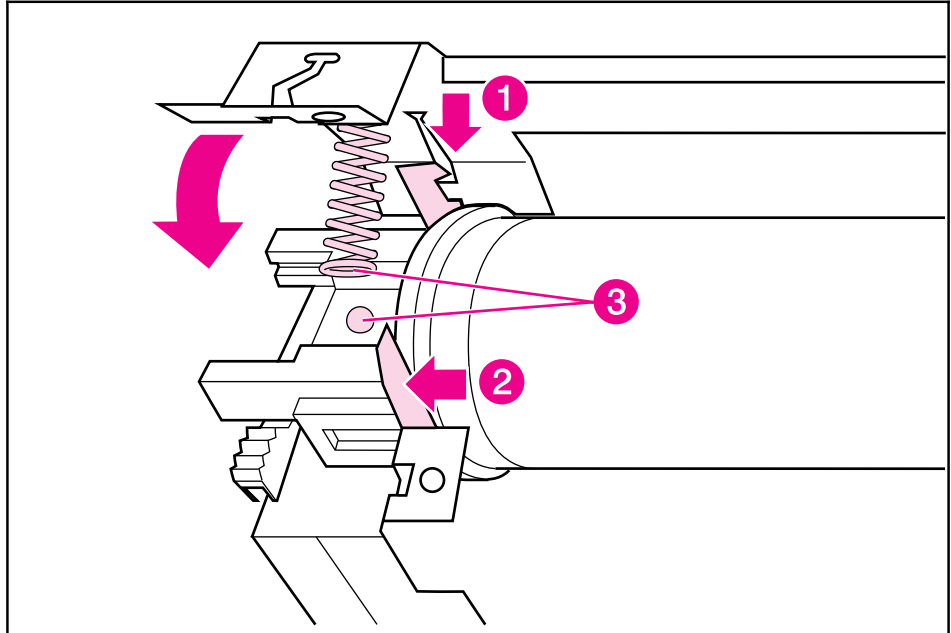

Fuser Pressure Plate Replacement

Heating Element

- 1 Remove Printer Covers, Delivery Assembly (Figures 6-9 and 6-10), and Fuser Pressure Plate (Figure 6-11).
- 2 Remove the wire cover (on the right side of the printer) for the Heating Element wires by pressing in on the tab and pulling outward (Figure 6-13, callout 1).

Figure 6-13

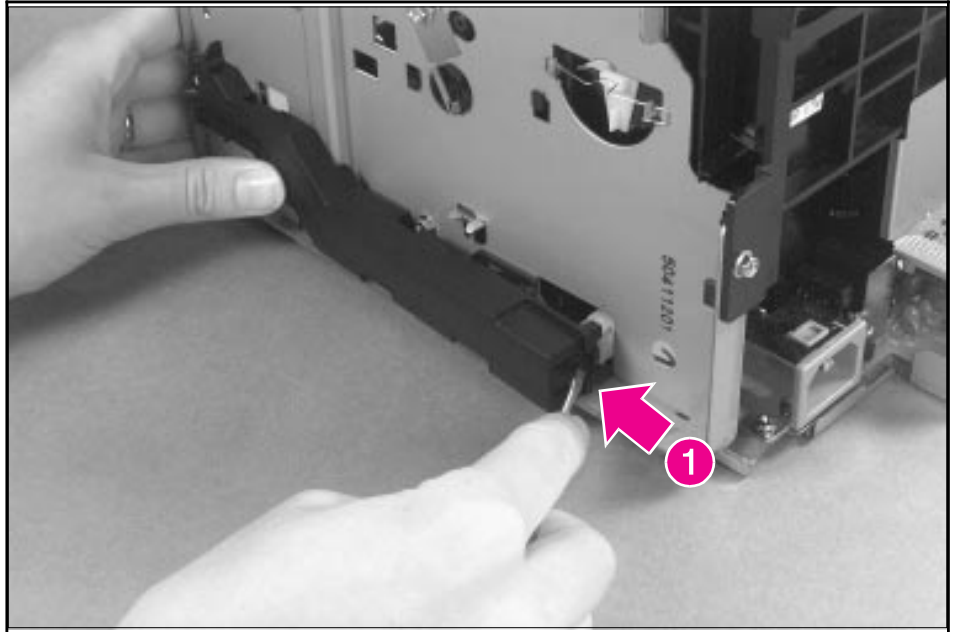

Heating Element Removal (1 of 3)

- 3 Disconnect the AC voltage to the Heating Element by releasing the connector located on the DC Controller. Press down on the connector release with a small, flathead screwdriver (Figure 6-14, callout 1). (Since this is a small space, it is much easier to reach the connector with a screwdriver.) Pull straight out (Figure 6-14, callout 2).

Figure 6-14

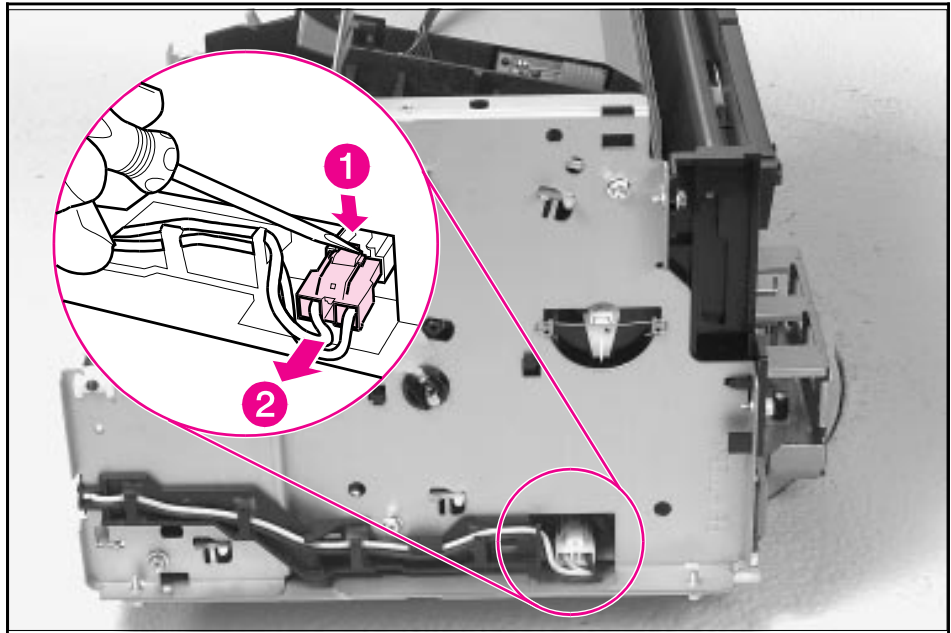

Heating Element Removal (2 of 3)

- 4 Remove the wire from the wire guides along the right-side of the printer.
- 5 Disconnect the thermistor feedback connector in the left front side of the Fusing Assembly (Figure 6-15).

Figure 6-15

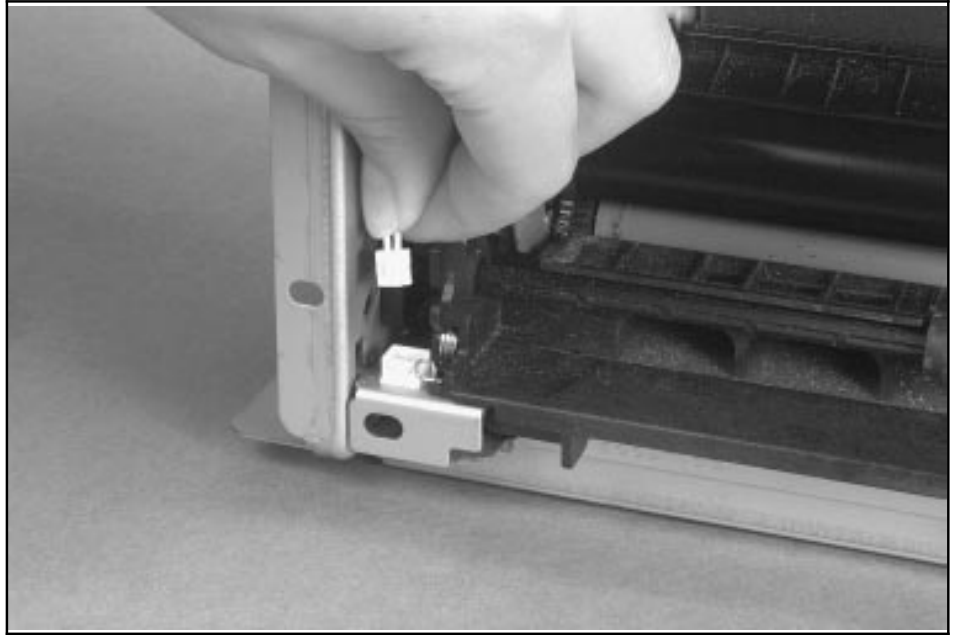

Heating Element Removal (3 of 3)

- 6 Lift the Heating Element out.

To reinstall

Make sure the connectors are properly reattached.

Pressure Roller

- 1 Remove Printer Covers, Delivery Assembly (Figures 6-9 and 6-10), Fuser Pressure Plate (Figure 6-11), and Heating Element (Figures 6-13 through 6-15).
- 2 Remove the Pressure Roller guide by lifting the edge (Figure 6-16, callout 1) and then rolling it gently backward (Figure 6-16, callout 2).

Figure 6-16

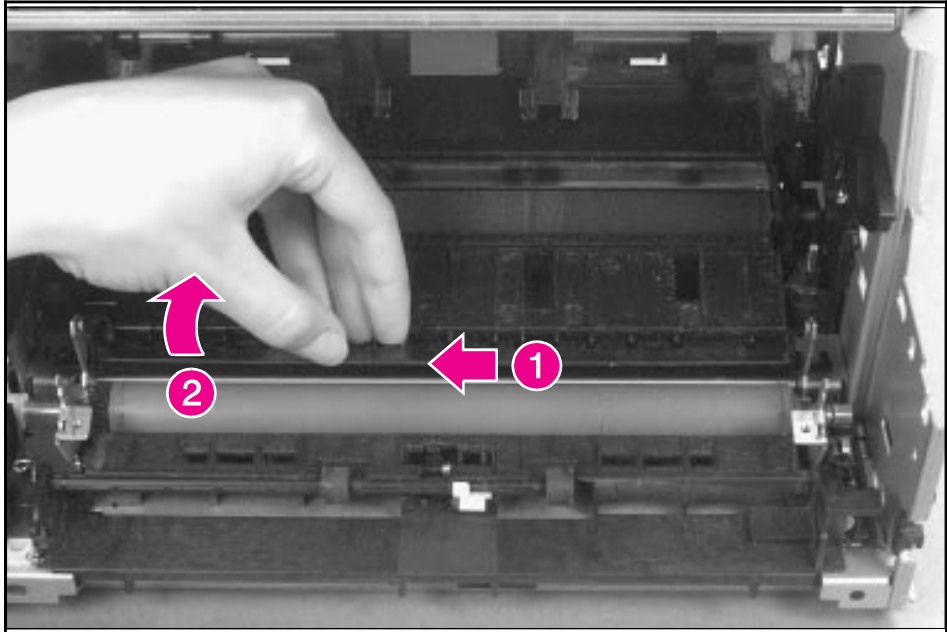

Pressure Roller Guide Removal

- 3 Lift the right end of the Pressure Roller up and out of the printer chassis.

Note The right end of the Pressure Roller is greased.

- 4 The left side will follow easily with the Pressure Roller gear still attached.

Note When reinstalling the Pressure Roller, apply a drop of grease to the grounding plate on the right side of the shaft. (Refer to Chapter 8 for a part number.)

Face-Up/Face-Down Lever

- 1 Remove Printer Covers, Delivery Assembly (Figures 6-9 and 6-10), Fuser Pressure Plate (Figure 6-11), and Heating Element (Figures 6-13 through 6-15), and Pressure Roller (Figure 6-16).
- 2 Rotate the lever forward 90 degrees (past the spring) and pull it straight out the front of the printer.

To reinstall

- 1 Make sure the lever arm is on the left and is initially pointing downward.
- 2 Pull the spring forward using needlenose pliers.
- 3 Slide the short, round tabs into the grooves on the Separation Guide Assembly. The machined ridges on the lever will face you.
- 4 Release the spring so it falls in place in front of the square tab (Figure 6-17).

Note

While the shape of the lever was changed for the HP LaserJet 6L (a stiffening rod was also added), these procedures for Face-Up/Face-Down Lever removal remain unchanged. Figure 6-17 shows the lever from an HP LaserJet 5L.

Figure 6-17

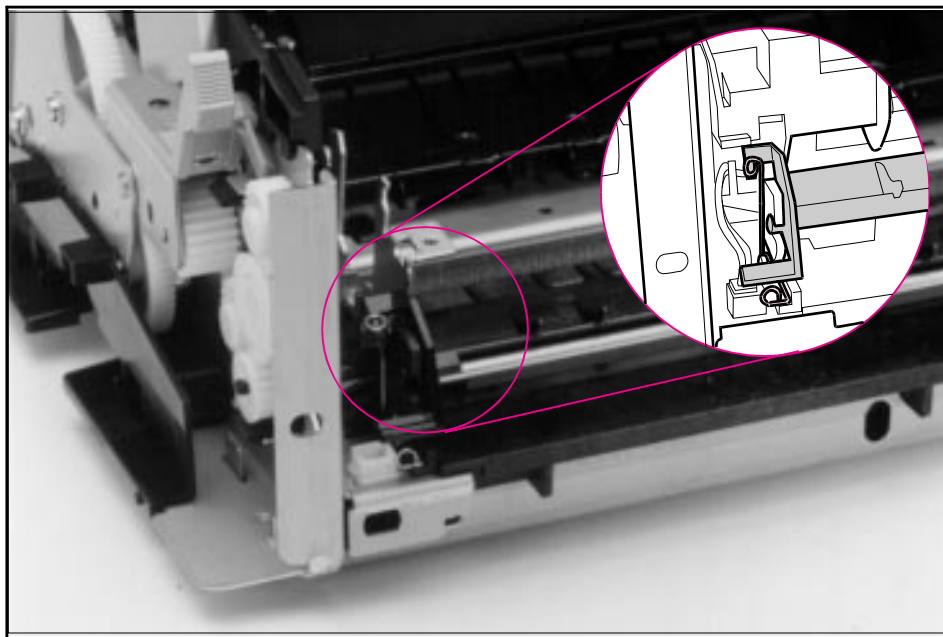

Face-Up/Face-Down Lever Replacement

Note

You can tell when the lever is in place because there are two plastic grooves that fit precisely in front of the Exit Rollers, and you should be able to feel the spring's release mechanism.

Fuser Exit Roller Assembly

- 1 Remove Printer Covers, Delivery Assembly (Figures 6-9 and 6-10), Fuser Pressure Plate (Figure 6-11), and Heating Element (Figures 6-13 through 6-15), Pressure Roller (Figure 6-16), and Face-Up/Face-Down Lever (Figure 6-17).
- 2 Remove the gear from the left end of the roller shaft by pressing down on the catching mechanism with the small flathead screwdriver and pulling the gear away.
- 3 Remove the Exit Roller Assembly by pressing the small, white tab upward (Figure 6-18, callout 1) and rotating it around (Figure 6-18, callout 2).

Note

While the shape of the white tab was changed for the HP LaserJet 6L, these procedures for Fuser Exit Roller Assembly removal remain unchanged. Figure 6-18 shows the white tab from an HP LaserJet 5L.

- 4 Slide the Exit Roller Assembly forward and out to the right of the printer.

Figure 6-18

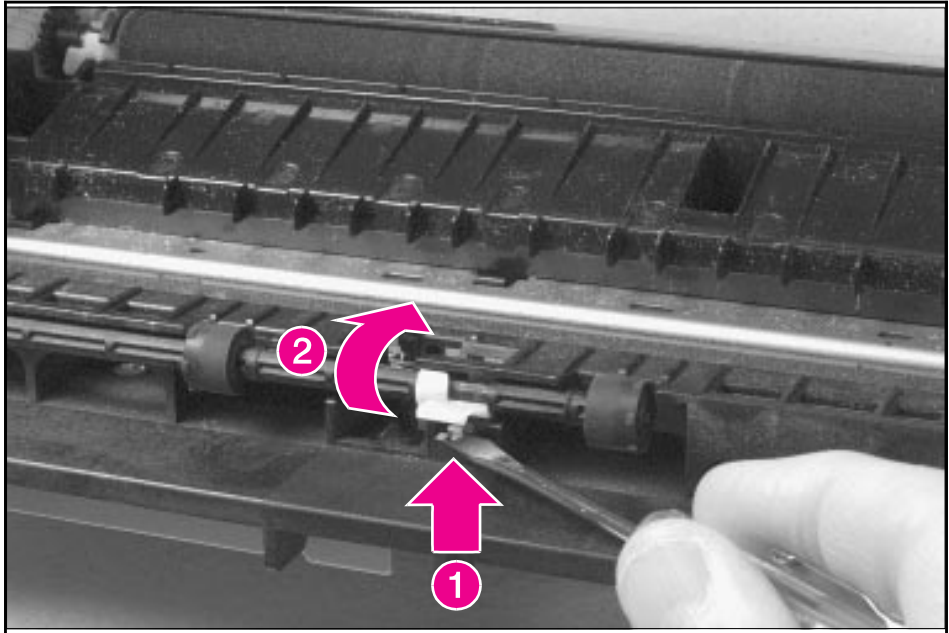

Fuser Exit Roller Removal

Paper Exit Sensor Flag

- 1 Remove the Printer Covers, Delivery Assembly (Figures 6-9 and 6-10), and Fuser Pressure Plate (Figure 6-11).

Caution

Before proceeding to Step 2, examine the Paper Exit Sensor flag. It is important to note the position of the spring mechanism on the flag. The spring must be reinstalled to exactly this position.

- 2 Remove the Paper Exit Sensor flag by pressing down on the left side and pulling up on the right side.

To reinstall

Note

It is important that you reinstall the flag correctly, because installing it incorrectly will cause the Control Panel to display an error with the Paper Exit Sensor (PS201).

Place the left side of the flag in the correct position first, then slide the right side into place, making certain the spring is on top of the flag (Figure 6-19). If the spring exerts no pressure on the flag, it may require “respringing” by giving the spring an extra turn before reinstalling. The flag should fit snugly in place.

Figure 6-19

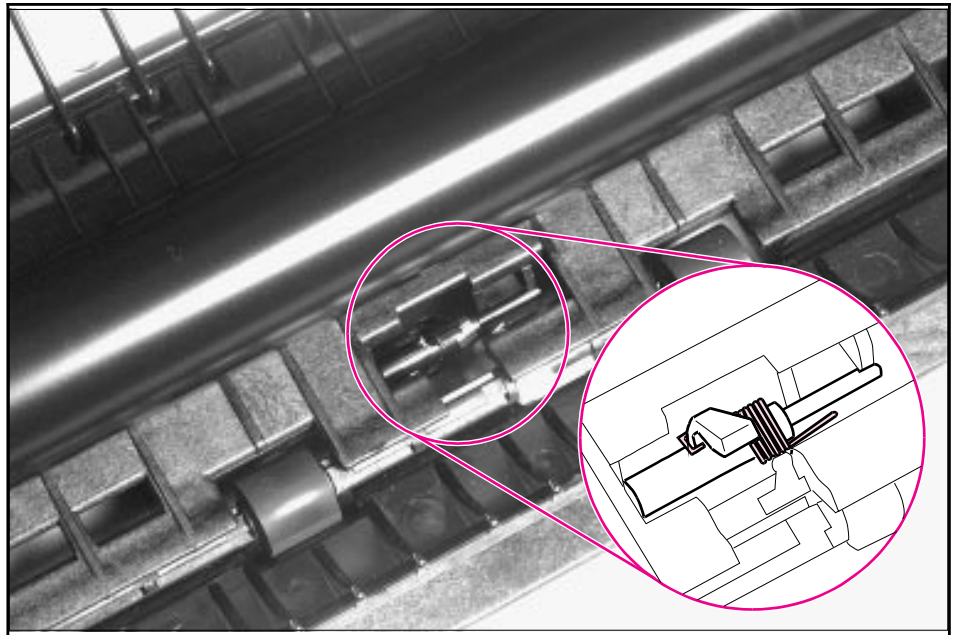

Paper Exit Sensor Flag Replacement

Top Assemblies

Laser/Scanner Assembly

- 1 Remove the Printer Covers.
- 2 Remove both Laser/Scanner connectors (Figure 6-20, callout 1).
- 3 Remove all (4) screws and lift the assembly straight off (Figure 6-20, callout 2).

Note

One of the four screws is longer than the other three. Upon reinstallation, the longer screw must be replaced in its original location.

Figure 6-20

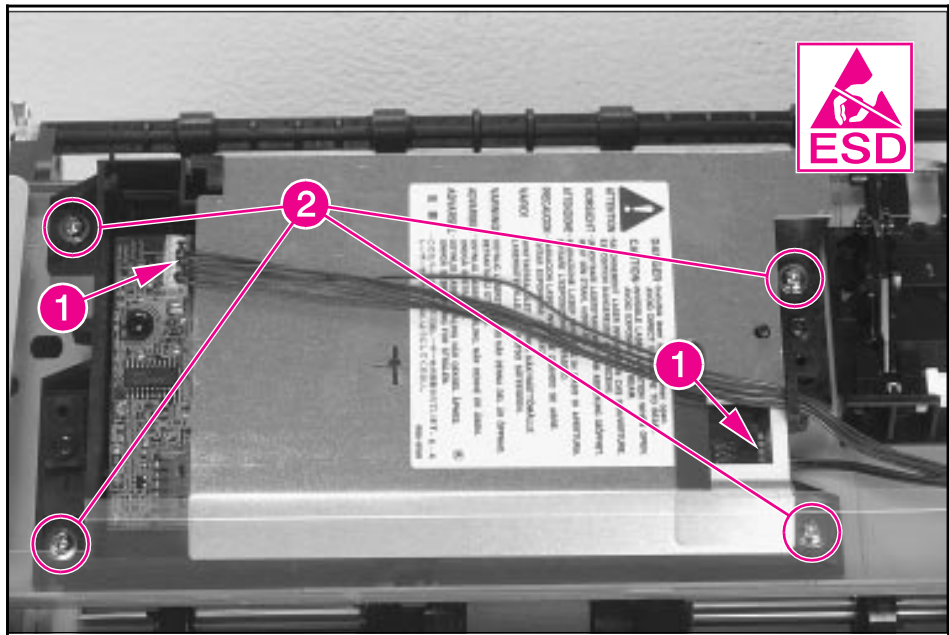

Laser/Scanner Assembly Removal

Solenoid

- 1 Remove the Printer Covers.
- 2 On the left side of the printer, remove the paper pickup gear (Figure 6-21, callout 1) by pressing the tabs in the center of the gear outward and pulling the gear off (Figure 6-21).

Figure 6-21

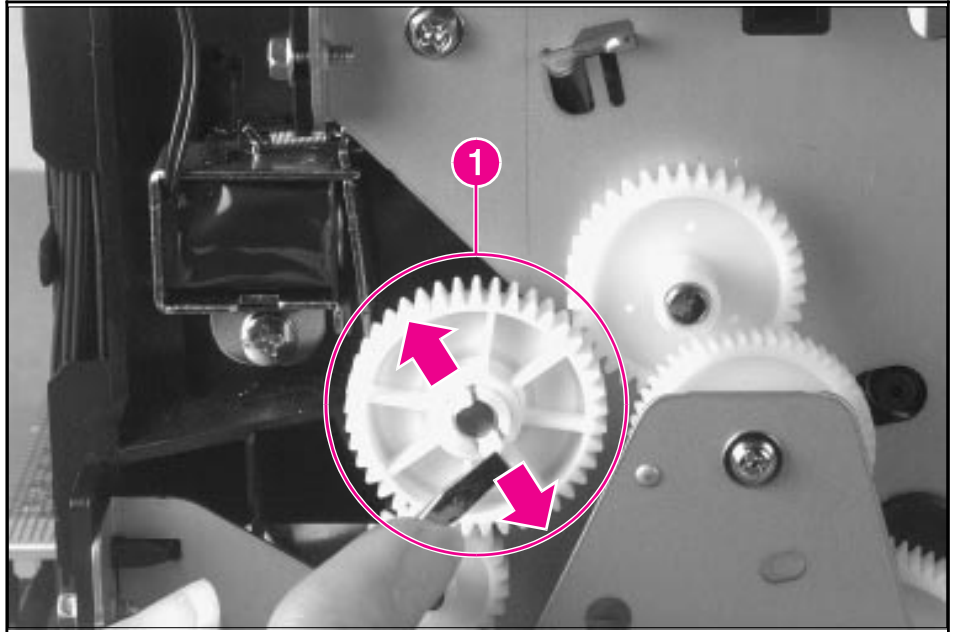

Solenoid Removal (1 of 2)

- 3 Remove the Solenoid connector (J204) from the DC Controller (Figure 6-22, callout 1).
- 4 Remove the self-tapping screw that holds the Solenoid in place (Figure 6-22, callout 2).
- 5 Unthread the wires from the printer chassis.
- 6 Lift the Solenoid off.

Figure 6-22

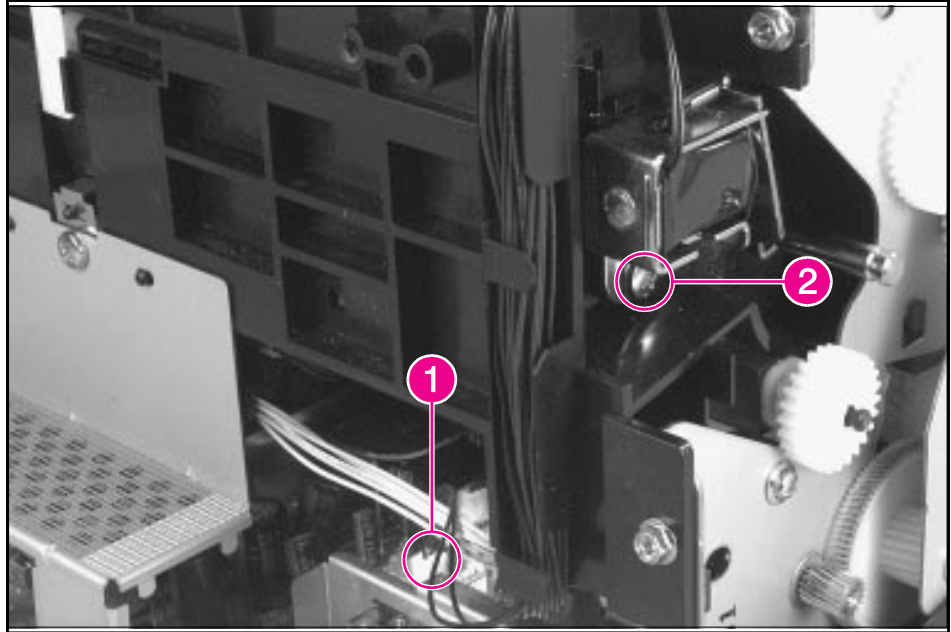

Solenoid Removal (2 of 2)

Note

When reinstalling this part, the Paper Pickup Gear is keyed to go on the shaft in only one way.

Pickup Roller Assembly

- 1 Remove the Printer Covers.
- 2 Remove the paper pickup gear (Figure 6-21).

Note

This gear is keyed to go on the shaft in only one way.

- 3 Remove the pickup roller grounding clip on the right of the printer by lifting each end of the clip up and over the two metal guides and sliding the clip off. Figure 6-23 depicts the clip from an HP LaserJet 5L. The clip from an HP LaserJet 6L (and some HP LaserJet 5Ls) is shaped differently.

Figure 6-23

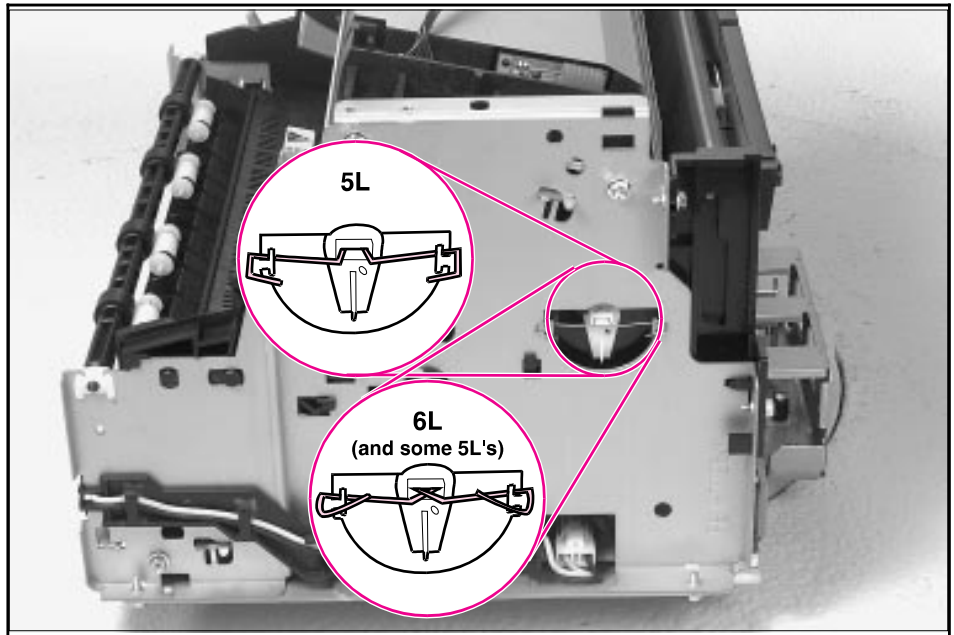

Pickup Roller Assembly Removal (1 of 2)

- 4 Using needlenose pliers, pull the bottom of the bushing out (Figure 6-24, callout 1), then turn it counter clockwise to release it (Figure 6-24, callout 2).

Figure 6-24

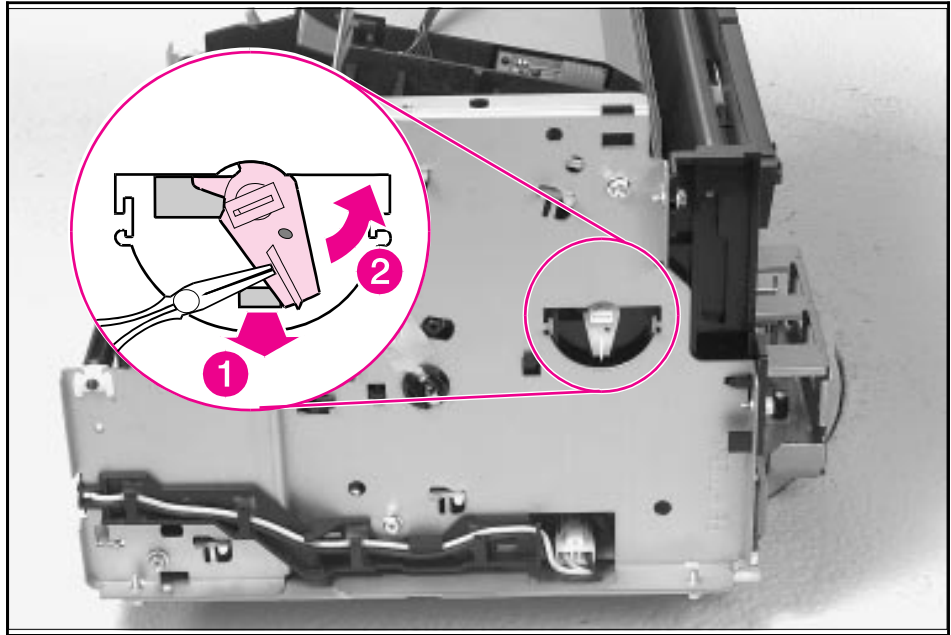

Pickup Roller Assembly Removal (2 of 2)

- 5 Lift the bushing out.
- 6 From inside the front of the printer, slide the right side of the Pickup Roller Assembly forward, then lift the left side out.

To reinstall

After placing the Pickup Roller shaft through on the left side, line up the Idler Roller tabs while repositioning the right side. Rock the shaft back and forth until the Pickup Roller and the Idler Roller tabs are correctly reinstalled.

Note

It is important that the Pickup Roller is placed back in with the two Idler Roller tabs up, so that they fit into the underside of the metal chassis behind the Laser/Scanner assembly (Figure 6-25).

Figure 6-25

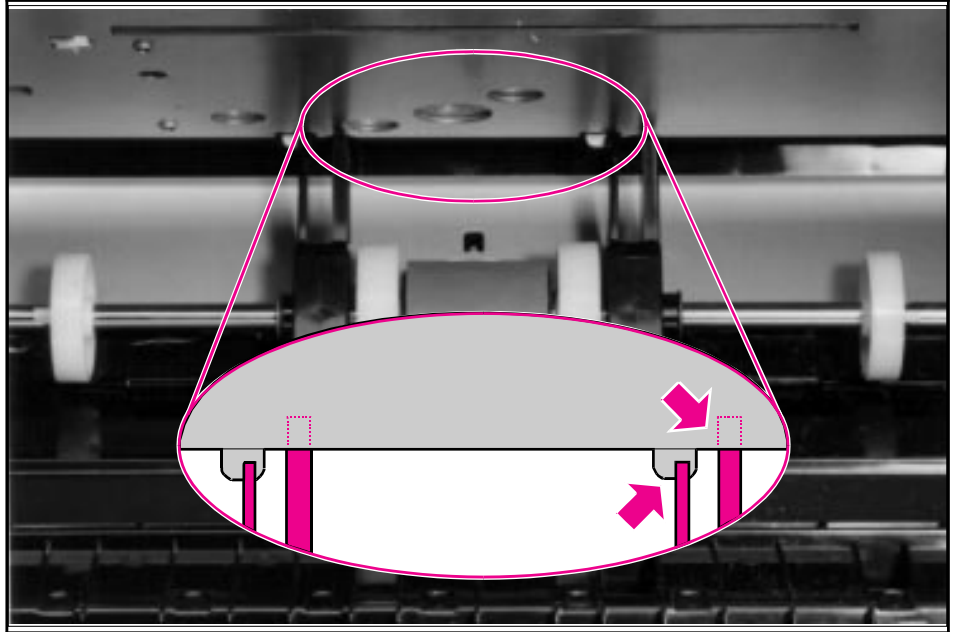

Paper Pickup Roller Assembly Replacement
(Inside/Front View)

Paper Feed Frame

- 1 Remove the Printer Covers.
- 2 Remove the Pickup Roller Assembly (Figures 6-23 through 6-24).
- 3 Disconnect the following:
 - Solenoid from the DC Controller at J204 (Figure 6-22, callout 1)
 - Two connectors from the Laser/Scanner (Figure 6-26, callout 1)
 - Connector from Top Cover/EP Cartridge Sensor on HP LaserJet 5L only (Figure 6-26, callout 2)
 - Connector from Switch 101 (Figure 6-26, callout 3)
 - Connector from Front Control Panel (Figure 6-26, callout 4)

Figure 6-26

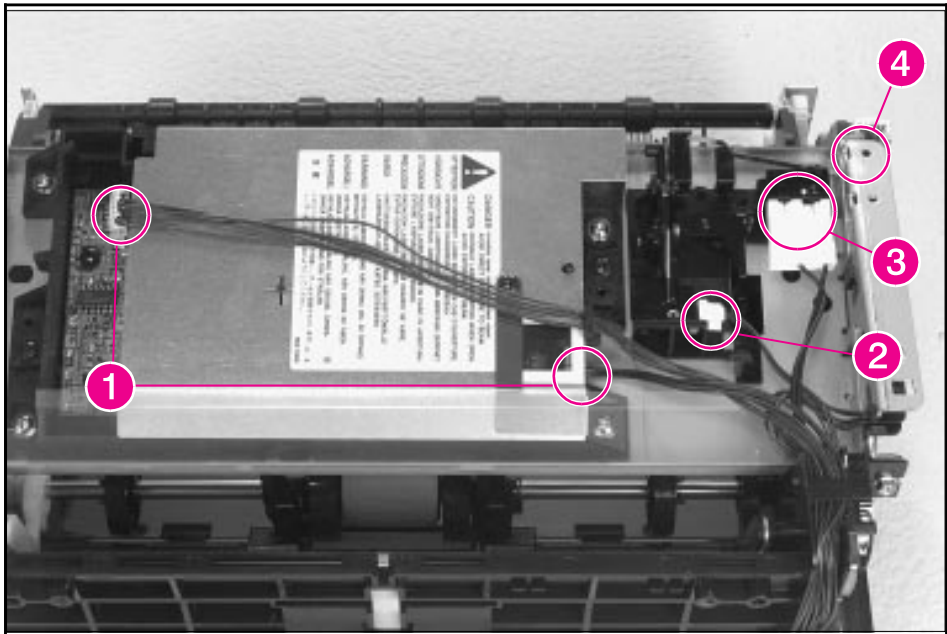

Paper Feed Frame Removal (1 of 4)

- 4 Release the catch on the control panel cable guide by using the small flathead screwdriver to push on the tab (Figure 6-27). Then slide the guide off.

Figure 6-27

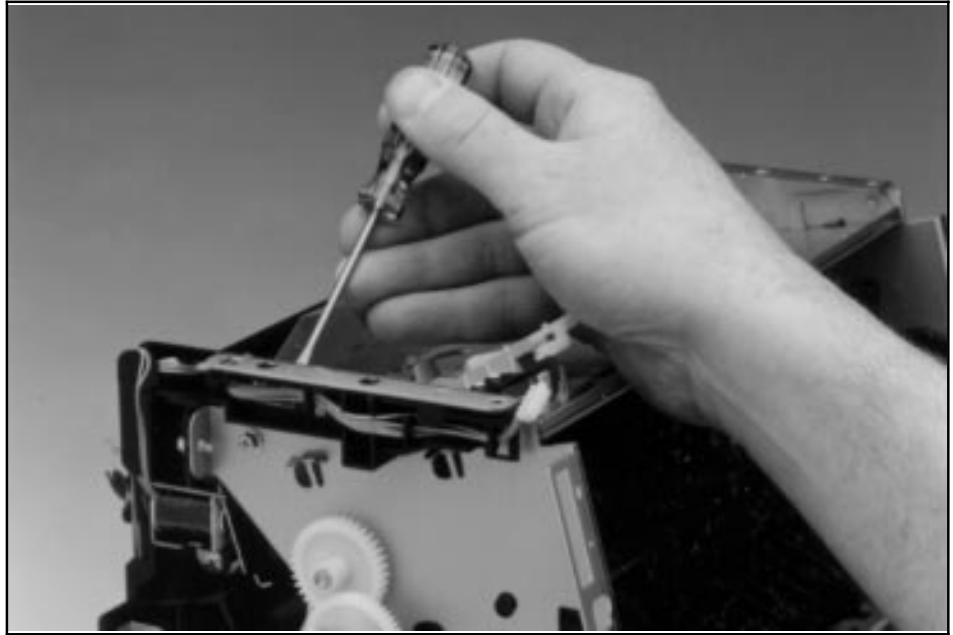

Paper Feed Frame Removal (2 of 4)

- 5 Remove the self-tapping screw from the back sheet metal plate and lift it off (Figure 6-28, callout 1).
- 6 Remove the (4) hex head screws from the Paper Feed Frame (Figure 6-28, callout 2).

Figure 6-28

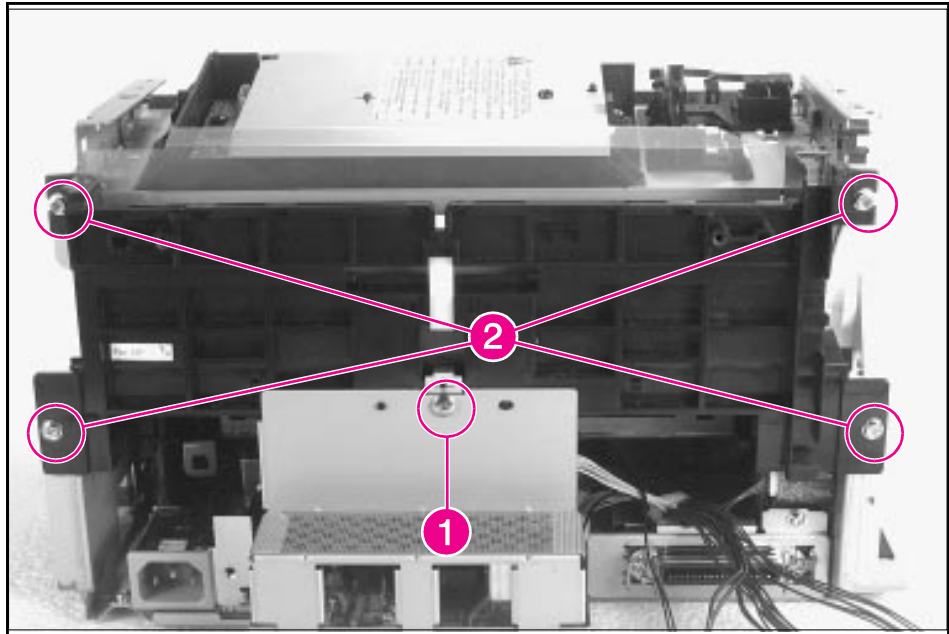

Paper Feed Frame Removal (3 of 4)

- 7 Release the sensor unit connector (Figure 6-29).

Figure 6-29

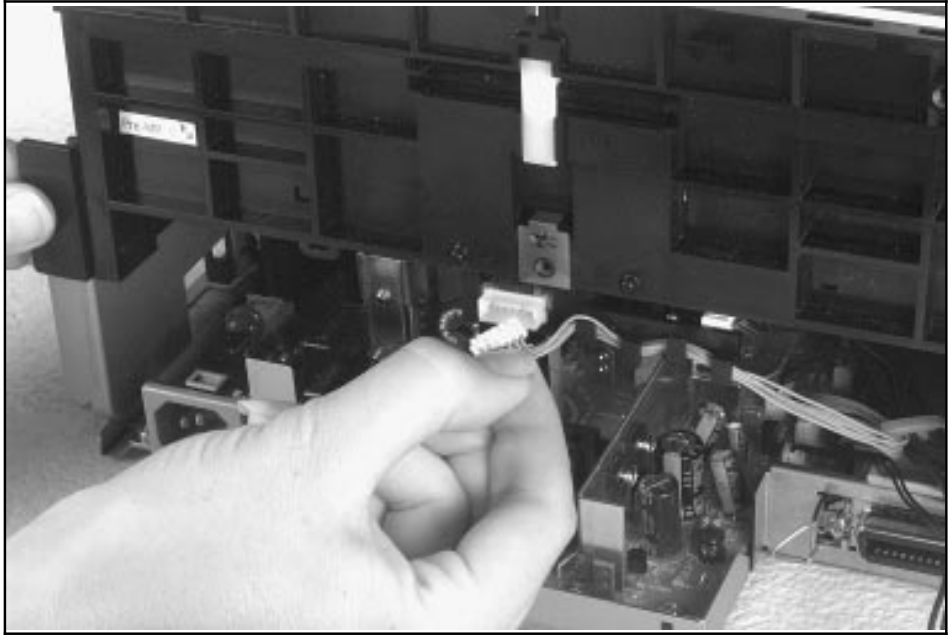

Paper Feed Frame Removal (4 of 4)

- 8 Verify that all cables are clear of the frame and pull the frame straight back to remove it.

To reinstall

The Paper Feed Frame may be easier to reinstall if you place the printer on its front, so that you can apply pressure while putting the screws back in place.

Transfer Roller Guide & Transfer Roller

- 1 Remove the Printer Covers, Pickup Roller Assembly (Figures 6-23 through 6-25), and Paper Feed Frame (Figures 6-26 through 6-29).
- 2 Looking at the back of the printer, note the two small, hook-shaped release tabs on each end of the Transfer Roller guide. Using a small, flathead screwdriver, carefully pry each tab outward to release it (Figure 6-30).
- 3 Roll the released portion of the guide up. To remove the Transfer Roller Guide, pull it off each end of the Transfer Roller shaft.

Figure 6-30

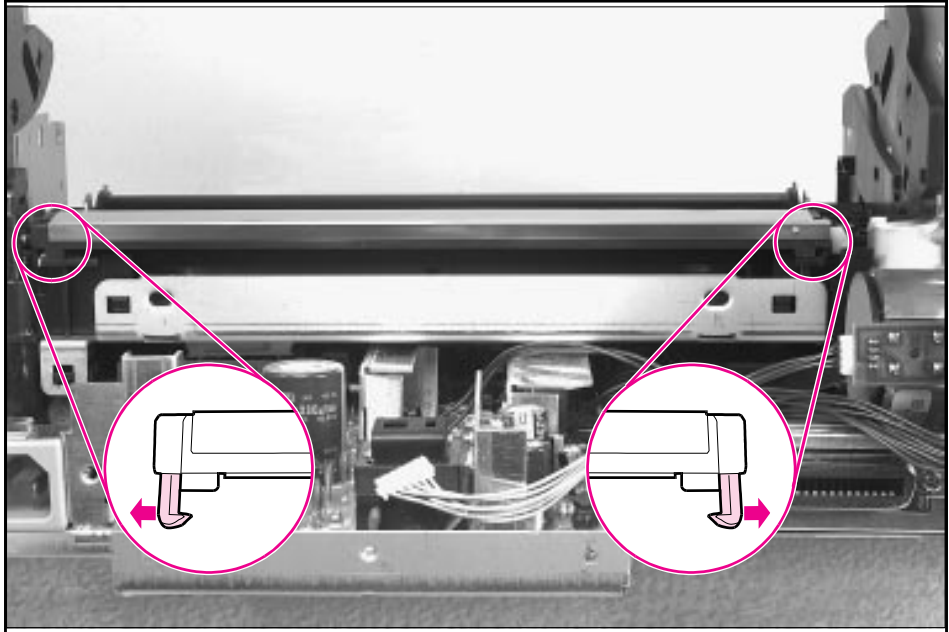

Transfer Roller Guide & Transfer Roller Removal
(Inside/Back View)

- 4 This exposes the Transfer Roller.

WARNING!

Do not touch the Transfer Roller or otherwise allow it to be contaminated.

- 5 Working from the front of the printer, gently pry the gear side of the Transfer Roller out first, then slide the other side out of its socket.

To reinstall

Some of the HP LaserJet 5L Printers contain a small metal spring under the Transfer Roller Guide. Upon reinstallation with these models, the small metal spring should rest under the Transfer Roller Guide.

Kick Plate

Caution

Be careful working with the Kick Plate and Separation Pad. The spring underneath the Kick Plate may stay attached to the Kick Plate, but it is also likely to spring away from the Kick Plate. Place the spring aside for Separation Plate disassembly.

- 1 Remove the Printer Covers and the Pickup Roller Assembly (Figures 6-23 and 6-24).
- 2 Press the Separation Pad (Figure 6-31). Allow the Kick Plate to pivot upward (a spring underneath will push it up). Lift the Kick Plate off its mounting pins.

Figure 6-31

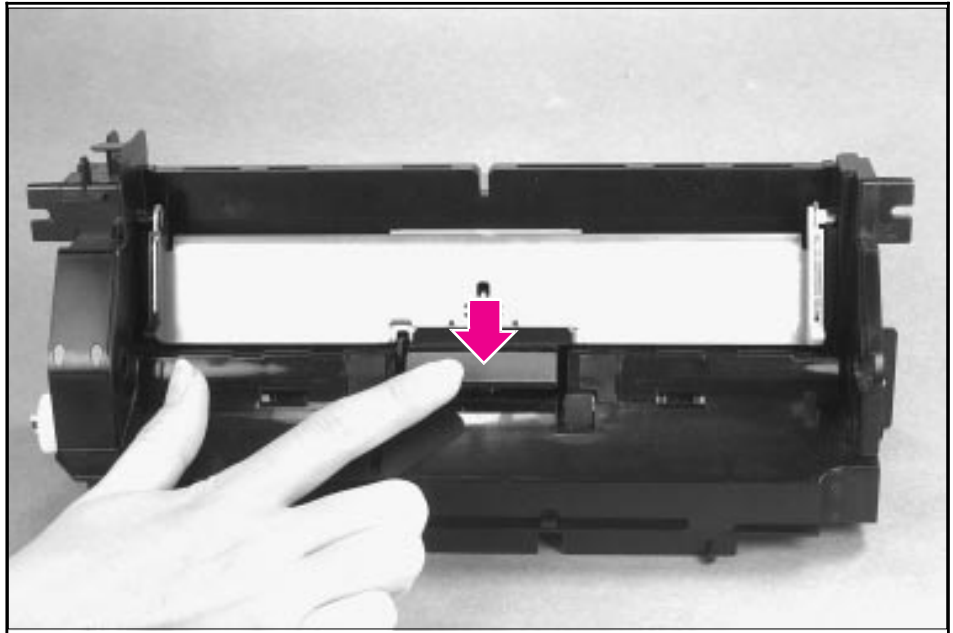

Kick Plate Removal

To reinstall

If the spring on the Kick Plate doesn't stay on the Kick Plate, replace the spring, making certain the diameter of the spring surrounds two lower pins on the Kick Plate and rests inside the third pin. Use needlenose pliers to place the spring correctly. (See Figure 6-32.)

Figure 6-32

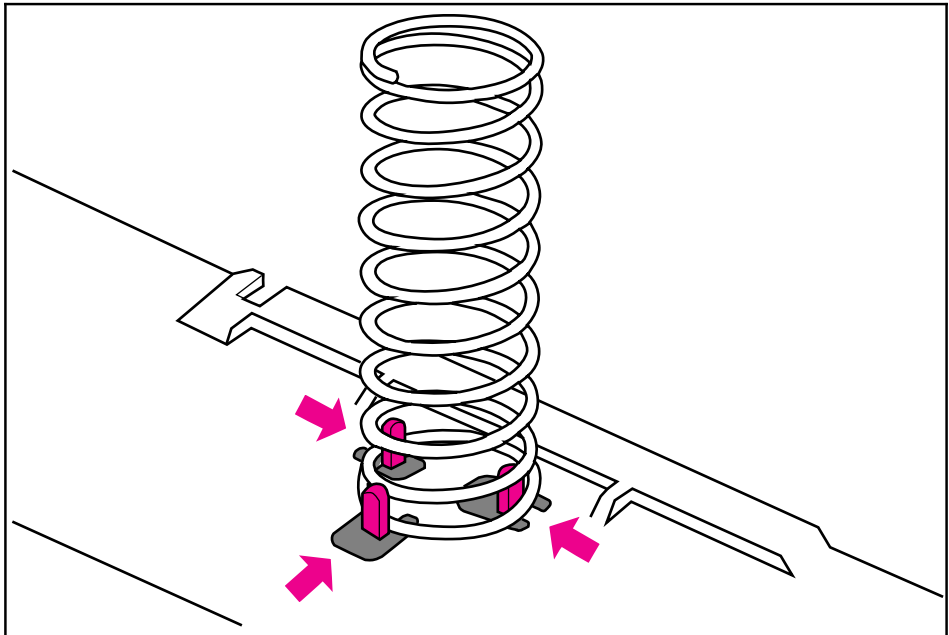

Kick Plate Spring Replacement

While rotating the Kick Plate into place, guide the other end of the spring onto the silver grounding plate located on the Paper Feed Frame.

Separation Pad

- 1 Remove the Printer Covers, Pickup Roller Assembly (Figures 6-23 and 6-24), and Kick Plate (Figure 6-31).
- 2 Lift the bottom of the white plastic tab on the rear of the Paper Feed Frame up slightly and slide it up, toward the top of the Paper Feed Frame. This will release the Separation Pad (Figure 6-33).
- 3 Lift the Separation Pad 90 degrees and slide its mounting pins out of their retainers.

Figure 6-33

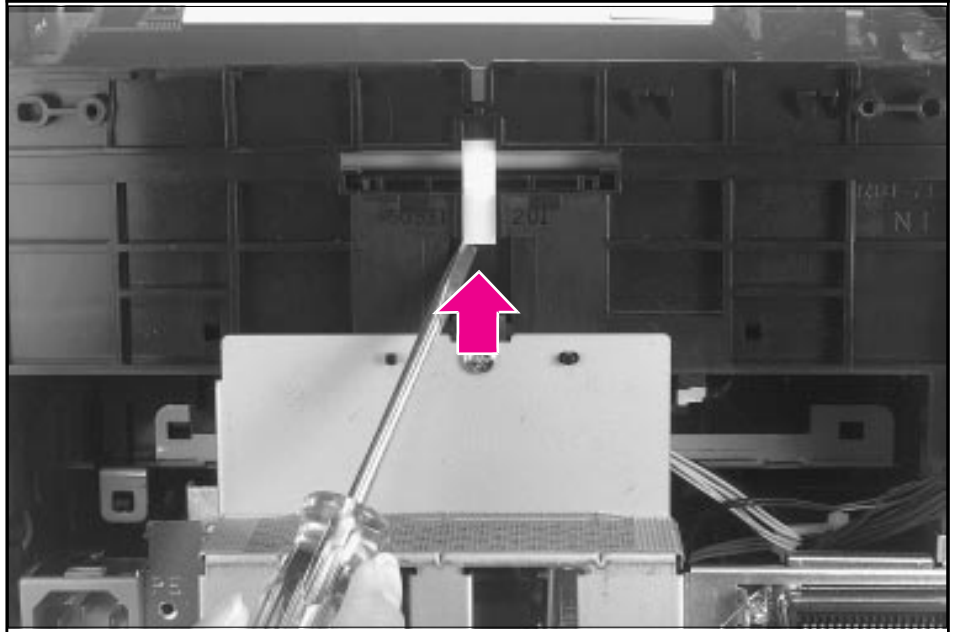

Separation Pad Removal

Subpads

Note

When you replace the Separation Pad, you should also replace the smaller subpads at the same time.

- 1 Place your index finger on the subpad.
- 2 Press toward the top of the printer.

Figure 6-34

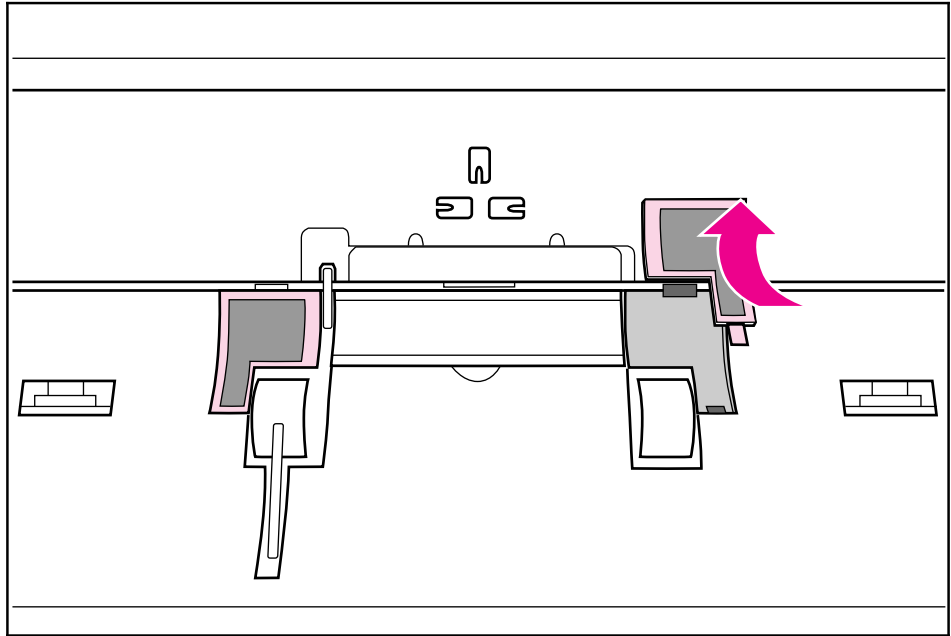

Subpad Removal

Feed Assembly

The Feed Assembly is located in the Paper Feed Frame.

- 1 Remove the Printer Covers, Pickup Roller Assembly (Figures 6-23 through 6-25), and Paper Feed Frame (Figures 6-26 through 6-29).
- 2 Turn the Paper Feed Frame upside down.
- 3 Remove the Feed Roller Shaft by lifting the plastic tab up (Figure 6-35, callout 1) and sliding it out the side of the Paper Feed Frame (Figure 6-35, callout 2).

Figure 6-35

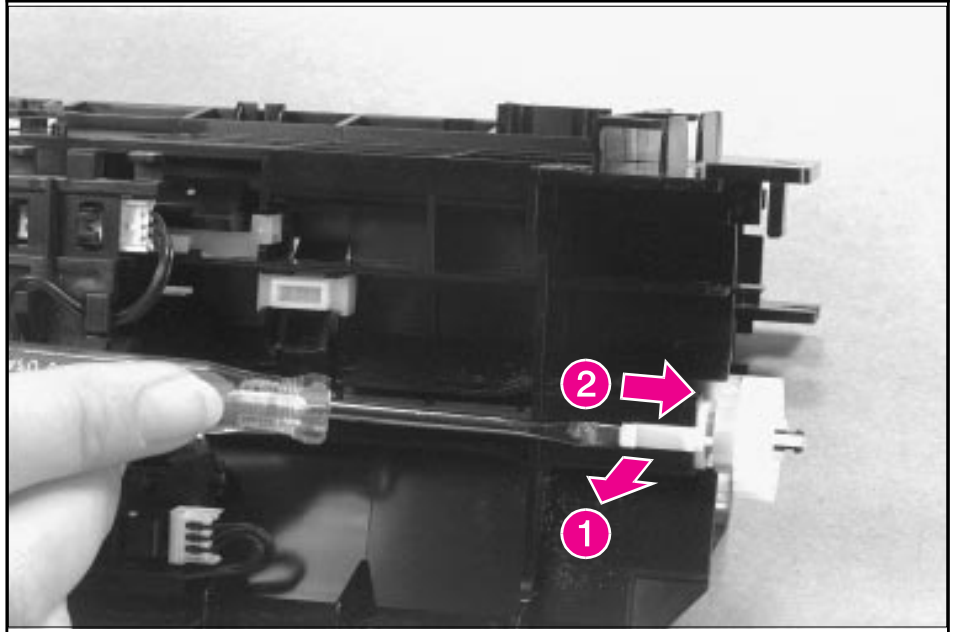

Feed Assembly Removal (1 of 3)

- 4 Remove the self-tapping screw that holds the Feed Assembly in place (Figure 6-36, callout 1).

Note

Before proceeding to Step 5, examine the tabs and how they fit into their slots (Figure 6-36, callout 2). The tabs must be reinstalled to exactly this position.

- 5 Remove the Feed Assembly.

Figure 6-36

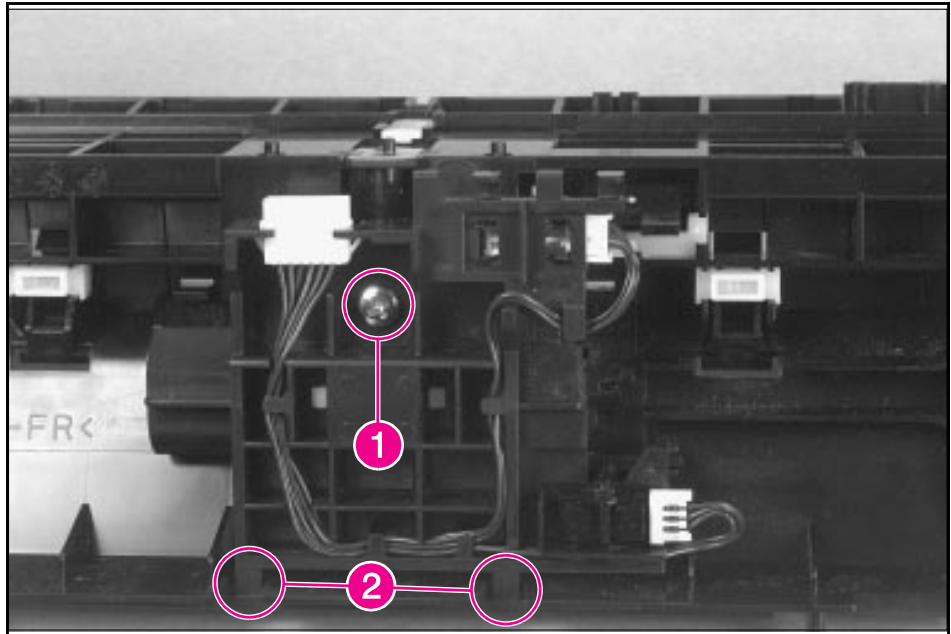

Feed Assembly Removal (2 of 3)

- 6 Turn the Feed Assembly over and place it in one hand with the roller-side down. Pop one of the tabs on the other side and the feed roller should fall into your hand (Figure 6-37).

Figure 6-37

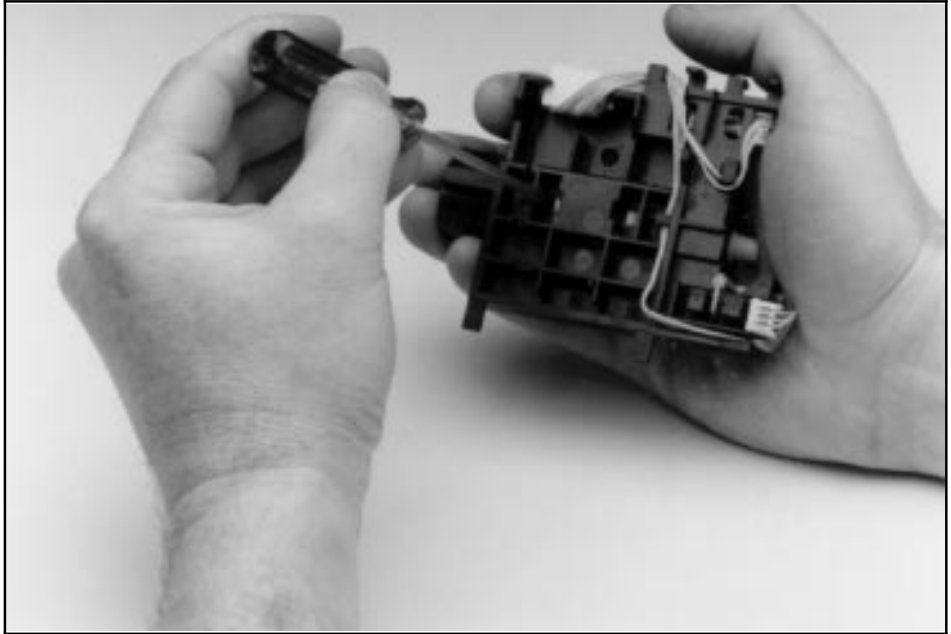

Feed Assembly Removal (3 of 3)

To reinstall

Before securing the screw, ensure the tabs on the Feed Assembly are positioned in their slots on the Paper Feed Frame (Figure 6-35, callout 2). Failure to do so will cause paper feed problems.

Bottom Assemblies

Memory Door Guide

- 1 Remove the Printer Covers.
- 2 Remove any extra memory.
- 3 Two tabs hold the memory door guide on the printer chassis. Press each tab inward (Figure 6-38).
- 4 Pull the memory door guide out.

Figure 6-38

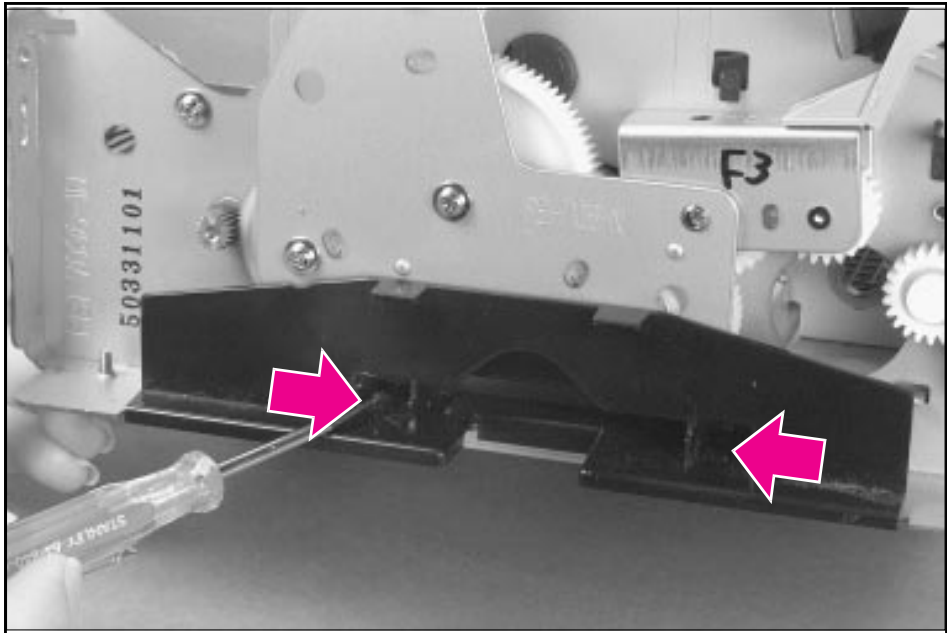

Memory Door Guide Removal

Motor

- 1 Remove the Printer Covers.
- 2 Remove the motor connector (Figure 6-39, callout 1).
- 3 Remove the memory door guide to expose the two motor screws.
- 4 Remove the motor screws (Figure 6-39, callout 2).
- 5 Lift the Motor out.

Figure 6-39

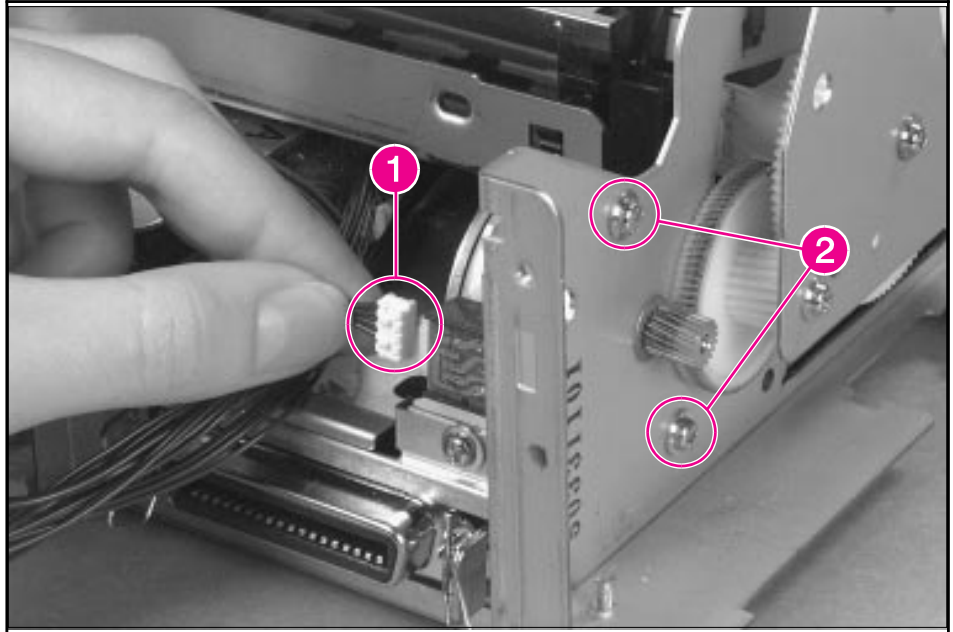

Motor Removal

DC Controller

- 1 Remove the Printer Covers.
- 2 Disconnect the motor connector from the motor (Figure 6-39, callout 1).
- 3 Disconnect the Solenoid connector from the DC Controller (Figure 6-22, callout 1).
- 4 Remove the back sheet metal plate and disconnect the PS202/PS204 connector (Figure 6-29).
- 5 Remove the AC Cable cover and disconnect the AC Cable from the DC Controller (Figures 6-13 and 6-14).
- 6 Tip the printer on its top, with the front facing you.
- 7 Remove the (4) screws (Figure 6-40, callout 1). One of the screws is a grounding screw. The location of the grounding screw is marked by a “star” etched into the bottom of the DC Controller.

Note

Make certain when you reinstall the DC Controller that the grounding screw with the washer is replaced in the same location.

Figure 6-40

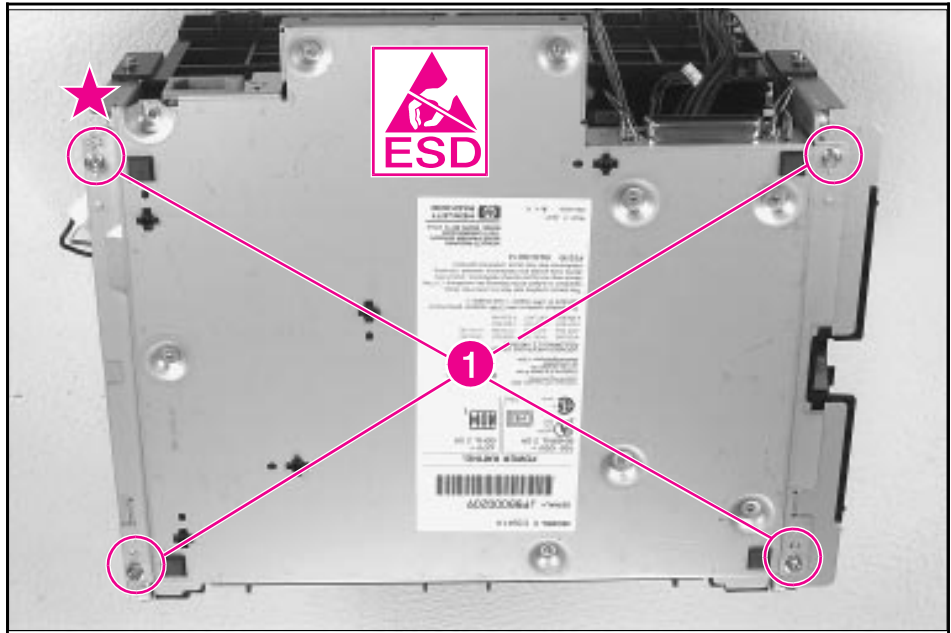

DC Controller Removal (1 of 3)

- Lift the bottom plate, rotating the plate toward you from the back as if hinged on the front. Release the Fusing Assembly connector (J206) (Figure 6-41, callout 1).

Caution

ESD SENSITIVE!

Figure 6-41

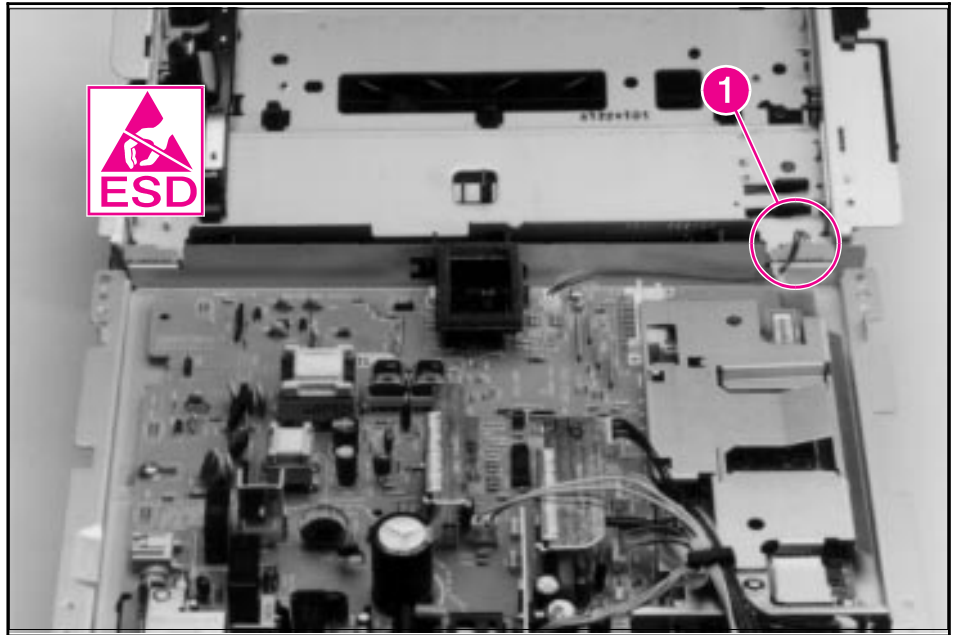

DC Controller Removal (2 of 3)

- 9 Remove the (7) remaining connectors (Figure 6-42, callout 1).
- 10 Remove the screws (5) that secure the DC Controller to the metal case (Figure 6-42, callout 2).

Figure 6-42

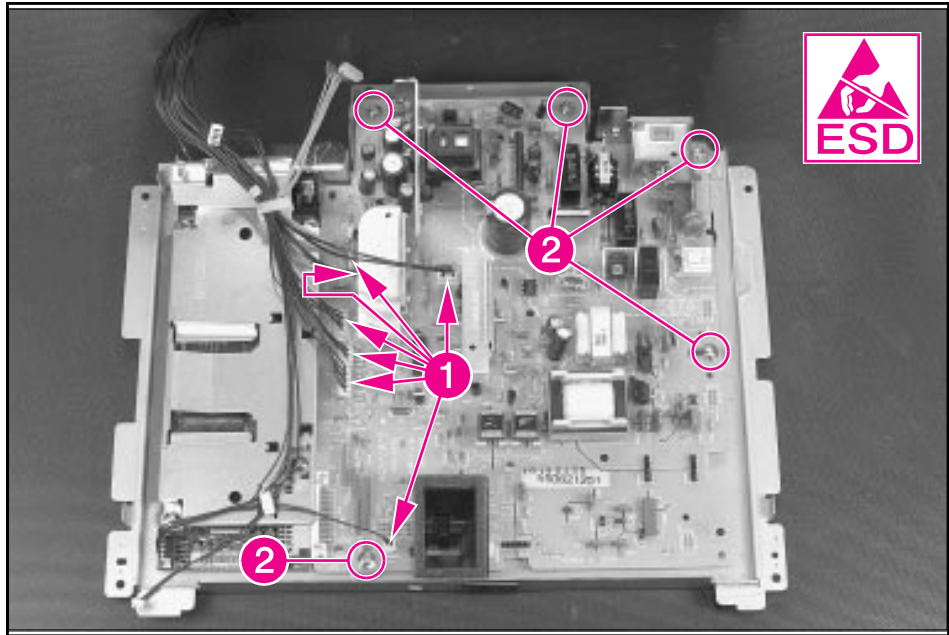

DC Controller Removal (3 of 3)

- 11 Remove the DC Controller by lifting gently on the side opposite the formatter, then sliding it out.

Caution

Be careful not to rotate the DC Controller as you remove it.

Note

When ordering, the DC Controller does not come with any connectors. Use the current connectors or refer to the connector chart in Chapter 8 for ordering information.

Formatter PCA

Caution

ESD SENSITIVE!

- 1 Remove the Printer Covers and complete the DC Controller removal direction up to step 8 (Figures 6-40 and 6-41).
- 2 Remove the two cable clips (Figure 6-43, callout 1).
- 3 Remove all (4) screws from the formatter cover (Figure 6-43, callout 2). Lift the I/O shield to remove it.
- 4 Remove the Control Panel display cable (Figure 6-43, callout 3).
- 5 Slide the formatter away from the DC Controller PCA to remove it from the connector.

Figure 6-43

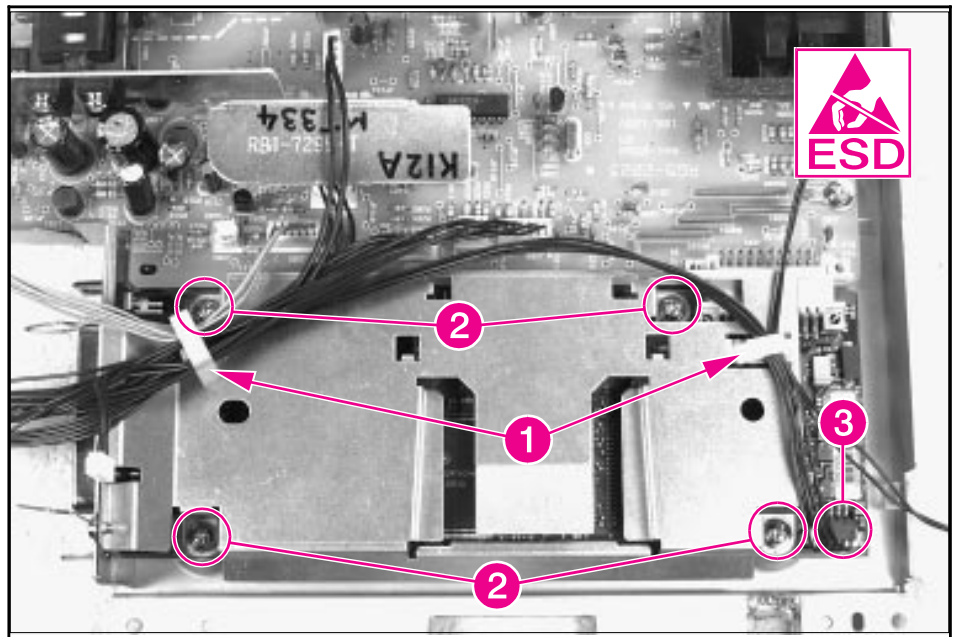

Formatter Board Removal

Note

The formatter I/O shield comes in two separate pieces. Be careful to order the correct pieces should you need to replace them.

Troubleshooting

Contents

General Troubleshooting Flowchart	7-3
Paper Path and Components	7-5
DC Controller Diagram	7-6
Printer Error Troubleshooting	7-7
Priority of Errors	7-7
Printer Status Messages	7-8
Service and Error Messages	7-10
Image Formation Troubleshooting	7-13
Check the Toner Cartridge	7-13
Image Defect Examples	7-14
Troubleshooting Checks	7-21
Engine Test	7-21
Half-Self Test Functional Check	7-22
Drum Rotation Functional Check	7-23
High-Voltage Power Supply Check	7-24
Paper Curl	7-26
Troubleshooting Tools	7-27
Paper Path Check	7-27
Repetitive Image Defect Ruler	7-28
Main Wiring Diagram	7-29

General Troubleshooting Flowchart

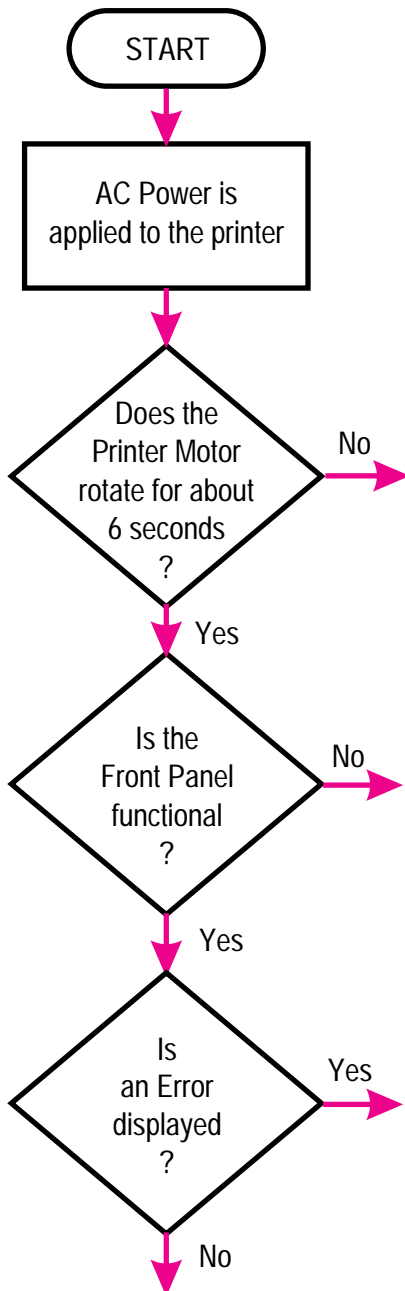

When the AC power is **first applied** to the printer:

- Both the printer motor and the laser/scanner motor rotate for 6 seconds.
- All of the LEDs illuminate for one second; the “Ready” LED will illuminate after 3 seconds.

If **no error** message is displayed, the Printer Door is firmly closed, and the toner cartridge is installed, but the motor does NOT rotate when AC power is applied to the printer:

- 1 Verify that AC power is present at the input power receptacle and that the power cord is firmly inserted into the printer.
- 2 Verify that FU102 is not open. (See Figure 7-2.)
- 3 Verify that motor connector J1 is seated into J401 of the DC Controller. (See Figure 7-2.)
- 4 Verify that the motor is correctly mounted to the printer chassis.
- 5 If all of these conditions are correct, replace the DC Controller PCA and/or the motor.

If the Control Panel is not functional:

- 1 Verify that the Control Panel connector J9 is seated into both the Control Panel and the Formatter PCA at J3. (See Figure 7-2.)
- 2 Verify that the Formatter PCA is firmly seated into the DC Controller PCA.
- 3 Perform a Print Engine Test. (See Figure 7-4.)
- 4 If the engine test is successful, replace the Control Panel first, then, if necessary, the Formatter PCA.
- 5 If the engine test is not successful, replace the DC Controller PCA.

If the control panel displays an error, refer to the appropriate section in this chapter to correct the error.

Continued on following page

General Troubleshooting Flowchart (continued)

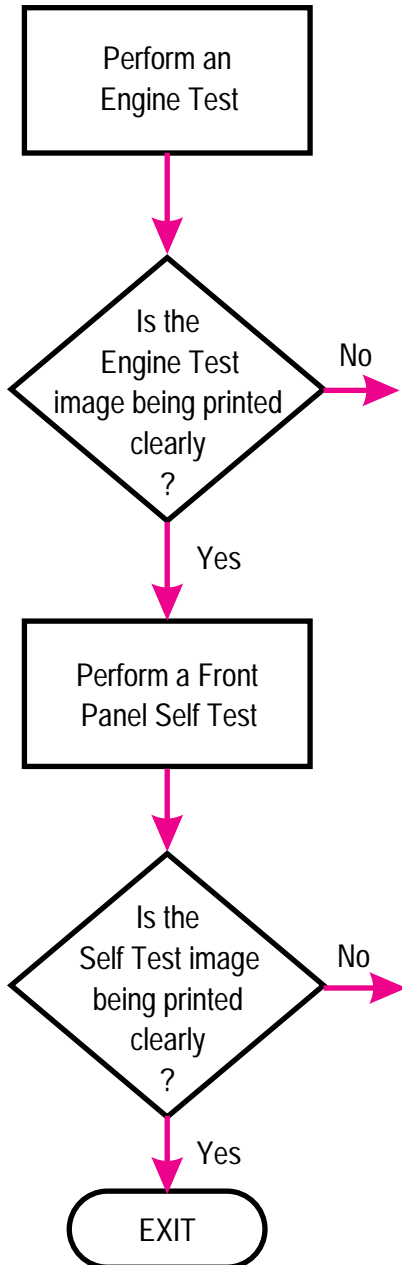

Refer to the section “Image Formation Troubleshooting,” later in this chapter.

If the engine test produces a clear print image, yet a Self Test is not generated by initiating the Control Panel self-test procedure, replace the Formatter PCA.

Paper Path and Components

Figure 7-1

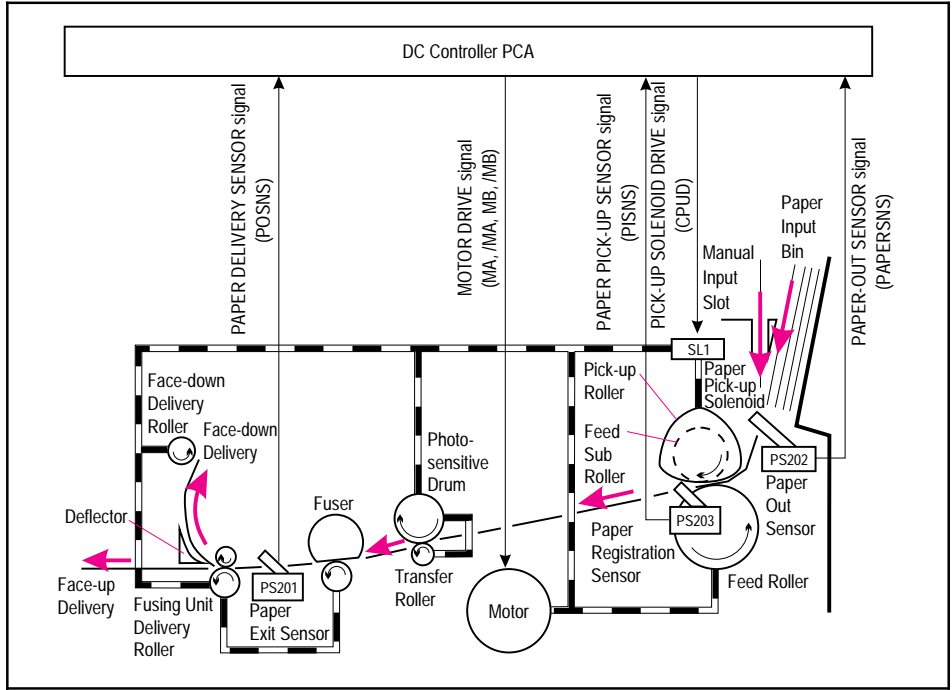

Paper Path and Components

DC Controller Diagram

Figure 7-2

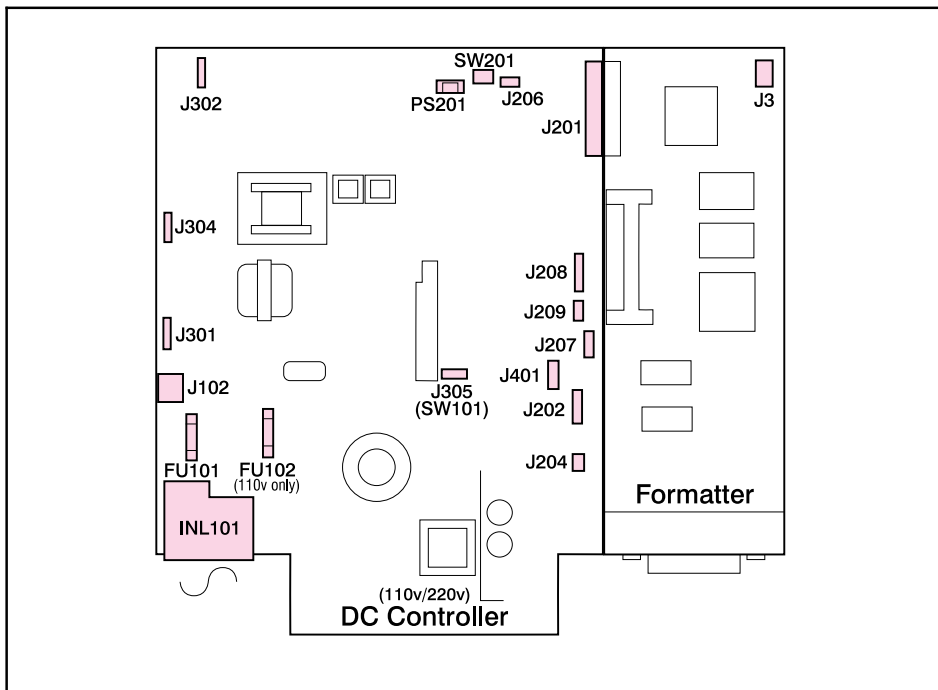

DC Controller PCA Components

J3	Control Panel Connector (Formatter PCA)	J202	Paper Registration and Paper-Out Photosensors (PS203 and PS202)
J102	Fusing Assembly	J206	Fusing Assembly (thermistor feedback)
J201	Formatter PCA Connection	J207	Scanner Motor
J204	Paper Pickup Solenoid (SL1)	J208	Laser Driver/Beam Detect Circuitry
J301	Developer Bias Contact	J209	Door Open/No Toner Cartridge Photosensor (PS204) (HP LaserJet 5L only)
J302	Transfer Roller Contact	J401	Motor
J304	Primary Roller Contact	FU101	
SW101	+12A Vdc Shutoff Switch	FU102	110 volt only
SW201	Engine Test Print Switch	INL101	Input Power Receptacle
PS201	Fusing Assembly Exit Photosensor		

Printer Error Troubleshooting

Information regarding printer status is conveyed by two methods: 1) the printer's Control Panel lights and 2) feedback through the bi-directional I/O that displays at the PC. The basic method of determining error messages uses patterns of lights on the Control Panel LED. Printer messages are categorized into two basic types:

- Status Messages
- Service and Error Messages

Note

Before troubleshooting the printer, cycle the power to the printer to see if the error persists.

Priority of Errors

Each error has a priority in relation to the others. If there is more than one error condition at the same time, the highest priority error will be displayed. The priority of errors is:

- 1 Service Errors
- 2 Door Open/No Toner Cartridge
- 3 Paper Jam
- 4 Paper Out
- 5 Memory Error
- 6 Manual Feed

Printer Status Messages

The following table lists printer LED messages and their meanings and describes recommended actions. For more information on the Front Panel layout, refer to “Using the Control Panel” in Chapter 3, “Installation and Configuration.”

Table 7-1 Printer Status Messages (1 of 2)



LEDs	Description	Recommended Action
	<p>Paper Out Error.</p> <p>Door Open or No EP Cartridge.</p> <p>Paper Jam.</p>	<p>Add paper.</p> <p>Close the printer door and/or verify that the EP cartridge is installed.</p> <p>Clear paper jam.</p> <p>If you have completed these recommended actions and the error persists, see Table 7-3.</p>
	<p>Memory Error. There is either too much data or the data is too complex.</p>	<ol style="list-style-type: none"> 1. Turn Page Protection on within your software application or Windows. 2. Reduce the complexity of the print job. 3. Reduce resolution to 300 dpi within your software application or Windows. 4. Add optional memory to the printer. 5. Make sure Enhanced I/O is on Auto Mode (PCL mode) and resend print job. (See Chapter 3, “PCL Printer Settings.”) 6. If the Auto-Continue variable is on within PJI, the printer will continue printing after 10 seconds. 7. If the Auto-Continue variable is off within PJI, you need to press the Front Panel Button to continue printing.
	<p>Incompatible Memory Card.</p>	<p>Remove the incompatible memory card and replace it with a 1, 2, 4, or 8 Mb, 70 nsec. or faster memory card. (See Chapter 8 for memory card part numbers.)</p>
	<p>Manual Feed. The printer is waiting for you to add a piece of paper to the single sheet input slot.</p>	<ol style="list-style-type: none"> 1. Make sure the correct paper is loaded into the printer. (See your <i>HP LaserJet 5L User's Manual</i> or the <i>HP LaserJet Printer Family Paper Specifications Guide</i> for more information.) 2. Press and release the Front Panel Button. 3. Turn off manual feed within your software application if you do not wish the printer to pause between sheets.

Table 7-2

Printer Status Messages (Continued 2 of 2)

LEDs	Description	Recommended Action
	<p>Sleep Mode</p>	<p>If the printer's LEDs remain off:</p> <ol style="list-style-type: none"> 1. The printer is in Sleep Mode. Press the Front Panel Button or open the EP Door. 2. Power is not supplied to the printer. Check power cord connections and the power source. 3. Print an engine test to determine if the print engine is functional. If the test is successful, replace the Formatter PCA. 4. See the General Troubleshooting Flowchart earlier in this chapter.

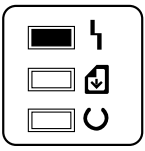
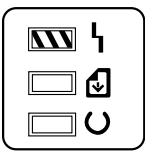
Occasionally you may add paper, close the printer door, add the toner cartridge, and clear a paper jam, only to find that the printer still displays an error message. If this happens, troubleshoot using Table 7-3 below.

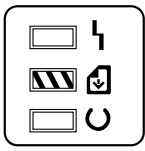
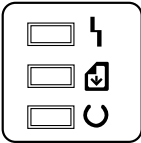
Note

If the error appears and persists only after you attempt to print a page, verify that the motor is functioning. (See “Printing an Engine Test” later in this chapter.)

Table 7-3

Unclearable Error

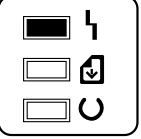
	<p>This error will persist if any of the three paper movement photosensors (PS201, PS202, and PS203) and/or their flags are not functional.</p> <ol style="list-style-type: none"> 1. Verify that all three photosensor flags are not blocked and move freely. (See Figure 7-1 to identify photosensor flag locations.) <ul style="list-style-type: none"> • Paper Out Flag (PS202) (See Figure 5-6.) • Paper Registration Flag (PS203) (See Figure 5-6.) • Exit Sensor Flag (PS201) (See Figure 6-18.) 2. Verify that all connectors are firmly seated. (See Figure 7-2 to identify connector locations on the DC controller.) <ul style="list-style-type: none"> • Door closed/EP Cartridge Photosensor connector (5L only) • Paper-Out and Registration Photosensor Connector (See Figure 5-6.) <p>Note: There is no connector for the Exit Photosensor (PS201) since it is located on the DC Controller PCA. This flag is located beneath the Fusing Assembly. (Refer to Figure 6-18.)</p> <p>If all of the flags move freely and all of the connectors are correctly seated, yet the error persists, replace the DC Controller PCA.</p>
---	---

Service and Error Messages

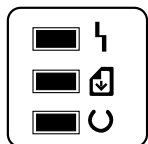

Service errors prevent further printer operation until some action is taken. When there is a service error, all of the lights will turn on in a steady state. **Press and hold the Front Panel Button** to see a pattern in the lights. (The error will only be displayed as long as this button is pressed.) Use Table 7-4, “Service and Error Messages,” to identify what type of service error has occurred.

Table 7-4 Service and Error Messages (1 of 3)

LEDs	Description	Recommended Action
	<p>ROM/RAM Error. An error was found with the ROM or RAM. The printer believes that the ROM is corrupted or an error has been found in the RAM.</p>	<ol style="list-style-type: none"> 1. Power-cycle the printer by unplugging the printer and plugging it back in. If this doesn't clear the error: 2. Unplug the printer, remove any optional memory, then power the printer back on. If the message clears, replace the memory card. 3. Replace the Formatter PCA.
	<p>Fuser Error. This indicates a fusing assembly malfunction.</p> <p>Note: Chronic fuser failures or fuser overheating or both are indicators of an uninterruptible power supply or battery backup being used with the printer. Uninterruptible power supplies (UPS) <i>should not</i> be used with the printer.</p>	<ol style="list-style-type: none"> 1. Unplug the printer for 10 minutes or more. 2. Verify that the fuser connector is firmly seated in J102 of the DC Controller PCA and that the thermistor connector (left of fusing assembly) is seated into both the printer chassis and J206 of the DC Controller PCA. 3. Remove the connector from J102 of the DC Controller (See Figure 6-14). Measure the resistance between pins one and two of the cable. (This procedure will measure the continuity of the ceramic heating element.) Normal resistance is 30 ohms +/- 10 ohms. If no resistance is measured, replace the heating element. 4. Remove the thermistor (temperature feedback) connector (See Figure 7-3). Measure the resistance between pins one and two. Normal resistance is 440K ohms +/- 30K at 20 degrees C. If the resistance is not measured replace the heating element. 5. If the resistance readings are correct, yet the error persists, replace the DC Controller.

Figure 7-3

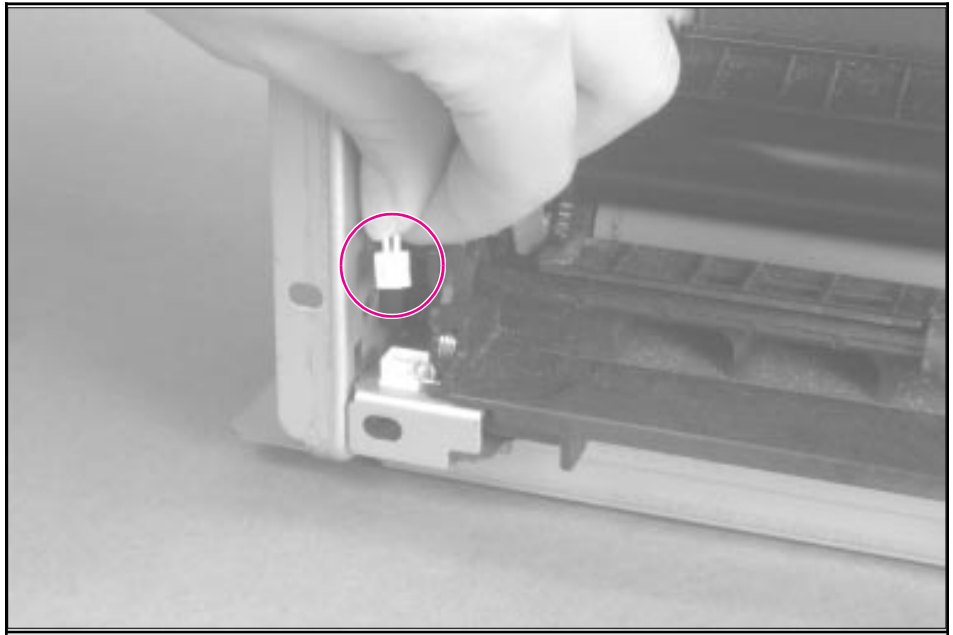

Heating Element Resistance Check

Table 7-4

Service and Error Messages (Continued 2 of 3)

LEDs	Description	Recommended Action
	<p>Beam Error. There are a number of causes for this error, and some of the causes may be transient. (They may disappear.)</p>	<ol style="list-style-type: none"> 1. Power-cycle the printer by unplugging the printer and plugging it back in. 2. Make certain the Laser/Scanner Assembly is correctly seated on the printer chassis. 3. Replace the Laser/Scanner cable (J208 on the DC Controller). 4. Replace the Laser/Scanner Assembly. 5. Replace the DC Controller PCA.
	<p>Engine Error. The formatter and engine are not communicating.</p>	<ol style="list-style-type: none"> 1. Power-cycle the printer by unplugging the printer and plugging it back in. If this doesn't clear the error: 2. Reseat Formatter to DC Controller PCA. 3. Replace the Formatter PCA 4. Replace the DC Controller PCA.

Table 7-4

Service and Error Messages (Continued 3 of 3)

LEDs	Description	Recommended Action
	<p>Scanner Error. Caused by a scanner malfunction.</p>	<ol style="list-style-type: none"> 1. Power-cycle the printer by unplugging the printer and plugging it back in. 2. Ensure condensation caused by moving the printer from a cold to a warm environment hasn't occurred. Allow the printer to acclimate to the warmer room. 3. Verify the two Laser/Scanner Assembly connectors are firmly seated. 4. Replace scanner cable J207 on the DC Controller PCA. 5. Replace the Laser/Scanner Assembly. 6. Replace the DC Controller PCA.
	<p>Formatter Error.</p>	<ol style="list-style-type: none"> 1. Power-cycle the printer by unplugging the printer and plugging it back in. 2. Disconnect the parallel I/O cable and try running a printer self test. Reconnect the parallel cable if the self test is successful and try host/printer communications again. 3. If the error persists, replace the Formatter PCA.
	<p>Firmware Error.</p>	<p>Note the LED pattern and the BiTronics error code. Contact HP technical support with this information as well as a description of what data was sent, the errors encountered prior to the firmware error, the condition of the printer prior to the error, and any other information that may help isolate the error.</p>
	<p>Processor Error.</p>	<p>Note the LED pattern and the BiTronics error code. Contact HP technical support with this information as well as a description of what data was sent, the errors encountered prior to the firmware error, the condition of the printer prior to the error, and any other information that may help isolate the error.</p>

Image Formation Troubleshooting

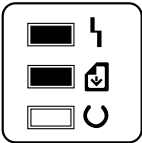
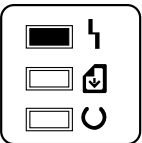
Check the Toner Cartridge

Image formation defects are many times the result of toner cartridge problems. If there is any doubt, always replace the toner cartridge before troubleshooting image defects.

Use the following check list to ensure that the toner cartridge is still operable.

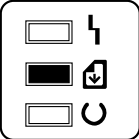
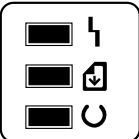
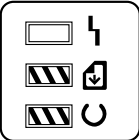
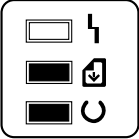
- Ensure that the toner cartridge is seated properly in the cavity.
- Inspect the toner cartridge for remaining toner.
- Check the expiration date of the toner cartridge (stamped on the cartridge box).
- Check the toner cartridge to see if it has been disassembled or refilled.

Note

The toner cartridge's full weight is 26.1 oz (730 grams), and its empty weight is 22.7 oz. (640 grams).

- Inspect the cartridge for leaking toner through worn seals. (If the drum has been manually rotated it may have caused internal damage and toner spills may result).
- Check the surface of the photosensitive drum in the cartridge to see if it has been damaged or scratched. Touching the drum will contaminate the photosensitive surface and may cause spotting and defects during printing.
- Blurred areas on the page may indicate that the drum has been exposed to light for too long. This causes permanent damage to the photosensitive drum. Replace the cartridge.

Image Defect Examples

This section illustrates some image defects and their possible causes. Since there are many variables in the printing process, you may encounter image defects that are not illustrated in the following examples. If you find a defect that is not illustrated, record the probable cause along with the printing environmental conditions and save a copy of the defect for future reference.

Each example lists, in order, the probable causes of the image defect.

Faded Print

Faded or light print may consist of a faded area, an entire page faded, or a block of vertically aligned white streaks.

- The toner cartridge may be getting low on toner. Gently shake the cartridge to redistribute the toner, or replace the cartridge.
- The paper may not meet HP's paper specifications (for example, too moist or too rough). (See the *HP LaserJet 5L User's Manual* or the *HP LaserJet Printer Family Paper Specifications Guide*.)
- Adjust toner density setting through your software or printer driver.
- EconoMode may be on. Turn it off through your software or printer driver.
- There may be discontinuities in the high-voltage contact points. Clean the high voltage contact points on the toner cartridge and transfer roller. (See Figures 7-5 and 7-6.)
- Complete a Half-Self Test to verify that the image is appearing on the drum. (See "Half-Self Test Functional Check" later in this chapter.) If this procedure isn't successful, replace the transfer roller.
- Replace the Laser/Scanner unit.
- Replace the DC Controller.

Staining

Stains usually appear as small, round, black dots that occur in the front or the back of a page. Sometimes wide, inconsistent stains appear.

- The paper may not meet HP's paper specifications (for example, too moist).
- You may be printing on the wrong side of the paper. Try removing the paper from the Paper Input Bin and turning it over. (The label on many reams of paper has an arrow indicating the print side.)
- The printer may need cleaning. See "Cleaning Your Printer," in Chapter 4.
- The toner cartridge may be damaged. Replace it if maintenance procedures do not improve print quality.



AaBbCc
AaBbCc
AaBbCc
AaBbCc



AaBbCc
AaBbCc
AaBbCc
AaBbCc

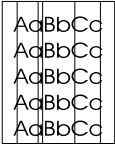

Vertical Lines

Sometimes vertically aligned black streaks or smears can appear on successive pages.

- The toner cartridge may be damaged. Replace it.
- The printer may need cleaning. See “Cleaning Your Printer,” in Chapter 4.
- Replace the heating element.



Horizontal Stripes

Sometimes horizontally aligned black streaks or smears can appear.

- The toner cartridge may not be installed properly. Remove the cartridge and reinsert it.
- The toner cartridge may be defective. Replace it.
- If the printer still has print quality problems, the printer may require cleaning.
- Replace the heating element.



Repetitive Defects

Sometimes light character shadows or repetitive marks appear on the page.

- Refer to the “Repetitive Image Defect Ruler” later in this chapter.
- The printer may need cleaning. See “Cleaning Your Printer,” in Chapter 4.
- The toner cartridge may be damaged, causing a repetitive black flaw on every printout. Replace the toner cartridge.
- If using transparencies, use a different type of overhead transparency.
- Your paper texture may be too coarse. Try changing to a paper with a smoother finish.
- The photosensitive drum of the toner cartridge may have been over-exposed to bright light, causing repetitive defects (usually a blurred area). Replace the toner cartridge.



Vertical White Stripes

The toner cartridge may be getting low on toner. Gently shake the cartridge to redistribute the toner, or replace the cartridge.

- The printer may need cleaning. (See “Cleaning Your Printer,” in Chapter 4.) You may also need to clean the mirror on the laser scanner by blowing air through the scanner to remove any dust particles.



Character Voids

Character voids are white areas within the parts of characters that should be solid black.

- If you are using transparencies when you experience this problem, try another type of transparency. Hewlett-Packard transparencies are designed to minimize character voids. (Because of the composition of transparency media, some character voids are normal.)
- You may be printing on the wrong side of the paper. Remove the paper and turn it over. (The label on many reams of paper has an arrow indicating the print side.)
- Your paper may not meet the requirements for the printer.



Background Scatter

Background scatter results from bits of toner distributed on the front or back of a printed page. Background scatter often is isolated to a specific area of the page.

- Check the environment. High humidity can cause this error.
- Change the paper type, weight, or surface finish. See appendix B of the User's Manual for paper specifications.
- If background scatter occurs on an envelope, try moving the text to an area with no seams. Printing on seams can cause this problem.
- If background scatter covers the entire surface of an envelope, try adjusting the print density through your software or printer driver.
- If this problem occurs on the back of a printed page, it may be caused by spilled toner inside the printer. See "Cleaning Your Printer" in Chapter 4.

Black Page

A page is completely black.

- The toner cartridge may not be installed properly. Remove the cartridge and reinsert it.
- The toner cartridge may be defective. Replace it.
- There may be discontinuities in the high-voltage contact points. Clean the high voltage contact points on the toner cartridge and transfer roller. (See Figures 7-5 and 7-6.)
- Replace the DC Controller or Laser/Scanner unit.

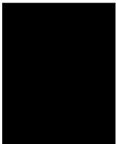



AaBbCc
AaBbCc
AaBbCc
AaBbCc

Dropouts

Dropouts are characters that are partially printed.

- The Paper Input Bin may have been loaded with too much paper. Make sure that no more than 100 sheets of paper are loaded.
- A single sheet of paper may be defective. Try reprinting the job.
- Try adjusting the print density through your software or printer driver.
- Try cleaning the rollers.
- The moisture content of the paper may be inconsistent, or the paper may have moist or wet spots on the surface. Try paper from a fresh ream or a different paper manufacturer.
- The paper may have been damaged by inconsistent manufacturing processes. Try paper from a different source.

Half of the Page Is Blank or Loss of Detail

The bottom of the page is blank, or part of a graphics image is cut off. This may mean that your page is too complex for the standard printer memory.

- Set resolution to 300 dpi through your software or printer driver.
- You may need to install additional memory in your printer. See Chapter 6 for memory installation instructions.
- Check your printer driver help screens for suggestions specific to your driver's settings.



AaBbCc
AaBbCc
AaBbCc

Curled or Wrinkled Sheets

Media is curled or wrinkled when using the Paper Output Bin.

- Verify that the media you are using meets paper specifications. (See the *HP LaserJet 5L User's Manual* or the *HP LaserJet Printer Family Paper Specifications Guide*.)
- Turn the paper over.
- Use the Front Output Slot by pushing the Paper Path Lever to the lower position. This provides the straightest paper path.
- Use Paper Input Support located behind the Paper Input Tray.

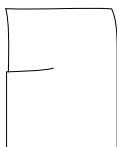

Blank Page (Occasional)

A page is completely blank. If you get *occasional* blank pages:

- Make sure your page length and margins are set correctly for the paper size you use. If you are printing on small media and your page is blank, try printing on larger media to see where the image is printing. Adjust margins accordingly.
- Some sharing devices or networks may generate a blank page as a separator. Try connecting the printer directly to the computer.
- Your printer may be feeding two or more pages at once because the paper is difficult to separate. Remove the paper from the Paper Input Bin and align the edges of the paper. Although fanning the paper is not generally recommended, it may be an effective way to decrease multi-feeds if the paper was poorly cut by the manufacturer and is sticking together. You may also try turning the paper around to feed the opposite end first.
- Your software application may send an extra page eject command. Check your software's printing configuration information. If you are using a word processing program, check for a natural page break and a forced page break that are close to each other, causing a blank page.

Blank Pages (all pages)

If *all* of your pages are blank:

- Make sure you removed the entire length of the sealing tape from the toner cartridge before you installed the cartridge.
- The toner cartridge may be completely out of toner. Replace the cartridge.
- Try printing a self-test page. (See Chapter 3.) If the page is still blank, the printer may need service.
- There may be discontinuities in the high-voltage contact points. Clean the high voltage contact points on the toner cartridge and transfer roller.
- Reseat the Laser/Scanner connectors.
- Replace the Laser/Scanner unit.
- Replace the DC Controller.

Dark Background

- Adjust the toner density setting through your software or printer driver.
- There may be discontinuities in the high-voltage contact points. Clean the high voltage contact points on the toner cartridge and transfer roller.
- Replace the Laser/Scanner unit.
- Replace the DC Controller.

AaBbCc
AaBbCc
AaBbCc
AaBbCc
AaBbCc

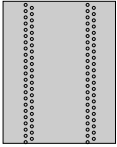

Dots

- Clean the static charge eliminator. (See Chapter 4, “Printer Maintenance.”)
- There may be discontinuities in the high-voltage contact points. Clean the high voltage contact points on the toner cartridge and transfer roller.
- Replace the transfer roller.

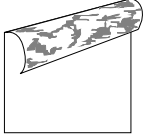

Dirt on the Back of the Page

- Use the image defect ruler to determine if the rollers are dirty. If so, clean them. Replace the rollers if they cannot be cleaned sufficiently.
- Clean the heating element.



Blank Spots

- The paper may not meet HP’s paper specifications. Select different paper
- The moisture content of the paper may be inconsistent, or the paper may have moist or wet spots on the surface. Try paper from a fresh ream or a different paper manufacturer.
- Replace the toner cartridge.
- There may be discontinuities in the high-voltage contact points. Clean the high voltage contact points on the toner cartridge and transfer roller.
- Replace the transfer roller.
- Replace the DC Controller.

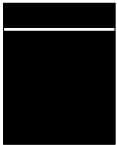

White Horizontal Line

- Replace the toner cartridge.

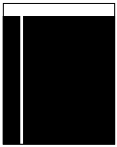

Faulty Registration/Skewed Image

- Unload the paper and re-stack it in the input bin.
- Readjust the guides to the width of the paper.
- Too many sheets of paper may have been loaded into the paper input slot. Load no more than 100 sheets of paper.
- The paper may not meet HP’s paper specifications. Select different paper.
- Clean the Paper Pickup Roller. If you cannot remove the dirt, the roller may be worn out. Replace the roller.
- Check separation pad and subpads. If they’re worn, replace them.
- Clean the Delivery Roller. If you cannot remove the dirt, replace the roller.
- Restack the paper in the paper input source and try reprinting the job.



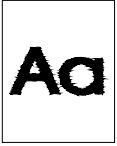

Distorted Image or BD Failure

- Make certain the printer is not facing the sunlight.
- The paper may not meet HP's paper specifications. Select different paper.
- Clean the Laser/Scanner Assembly by blowing compressed air in the slot on the bottom of the assembly.
- Make sure the two Laser/Scanner connectors are firmly seated.
- Replace the Laser/Scanner unit.
- Replace the DC Controller.

Troubleshooting Checks

Engine Test

The engine test print is used to verify that the print engine is functioning correctly. The Formatter PCA is completely bypassed during an engine test, so this test is useful for isolating printer problems. The engine test prints a full page of vertical lines down the entire printable area and is also useful for checking and adjusting registration.

Engine Test Button Location

The engine test print button is located on the DC Controller PCA. It is accessible through a hole at the front of the printer. (See Figure 7-4.)

Printing an Engine Test

The engine test button is accessible **without removing the covers**. To print an engine test, use a long, **non-metallic** object (such as a pen or pencil) to press the engine test button. A single test page is printed. (See Figure 7-4.)

Figure 7-4

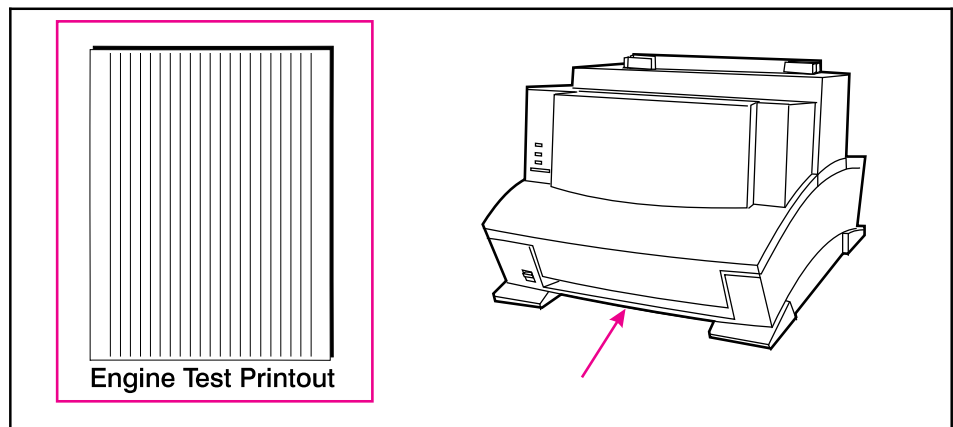

Engine Test

Half-Self Test Functional Check

The electrophotographic process can be subdivided into the following stages:

- Cleaning (removing excess toner from drum surface)
- Conditioning (placing a uniform electrical charge on drum)
- Writing (laser strikes surface of drum to create latent image)
- Development (formation of the toner image on drum)
- Transfer (charge to transfer the image to paper)
- Fusing (heat and pressure to produce a permanent image)

The purpose of the Half-Self Test Check is to determine which process is malfunctioning. Perform the test as follows:

- 1 Initiate a self test.
- 2 Open the Printer Door after the paper advances half-way through the printer (about 8 seconds after the Motor begins rotation). The leading edge of the paper should have advanced past the toner cartridge.
- 3 Remove the toner cartridge.
- 4 Open the toner cartridge's drum shield to view the drum's surface.
If a *dark and distinct toner image is present* on the drum's surface, assume that the first four functions of the electrophotographic process are functioning (cleaning, conditioning, writing and developing - see Chapter 5.) Troubleshoot the failure as a transfer or fusing problem.

If *NO image is present* on the photosensitive drum, perform the following functional checks:

- 1 Make sure you have removed the entire length of the sealing tape from the toner cartridge before you installed the cartridge.
- 2 Drum Rotation Functional Check.
- 3 High Voltage Power Supply Check.

Drum Rotation Functional Check

The photosensitive drum, located in the toner cartridge, must rotate for the print process to work. The photosensitive drum receives its drive from the Main Drive assembly. To verify whether the drum is rotating:

- 1 Open the Printer Door.
- 2 Remove the toner cartridge.
- 3 Mark the cartridge's drive gear with a felt-tipped marker. Note the position of the mark.
- 4 Install the toner cartridge and close the Printer Door. The start-up sequence should rotate the drum enough to move the mark.
- 5 Open the printer and inspect the gear that was marked in step 3. Verify that the mark moved.

If the mark did not move, inspect the Main Drive assembly to ensure that it is meshing with the toner cartridge gears. If the drive gears appear functional, and the drum does not move, replace the toner cartridge.

Note

This test is especially important if refilled toner cartridges have been used.

High-Voltage Power Supply Check

The High-Voltage Power Supply PCA provides the necessary voltages for the electrophotographic processes. A method for verifying the high-voltage system is given in the table below.

Table 7-5

High-Voltage Power Supply Check

Checks	Action
Toner Cartridge Connection Points	Visually inspect the three connection points on the underside, right end of the toner cartridge. If they are dirty or corroded, clean the connections. Use alcohol only. If damaged, replace the toner cartridge. (See Figure 7-5 below.)
High Voltage Connector Assembly	This assembly uses spring-loaded pins to contact the toner cartridge. (See Figure 7-6 on the following page.) Verify that the pins are not dirty or corroded and that the spring-loading action is functional. If the pins are dirty, clean using alcohol only; if damaged, replace the High Voltage Connector Assembly.

Figure 7-5

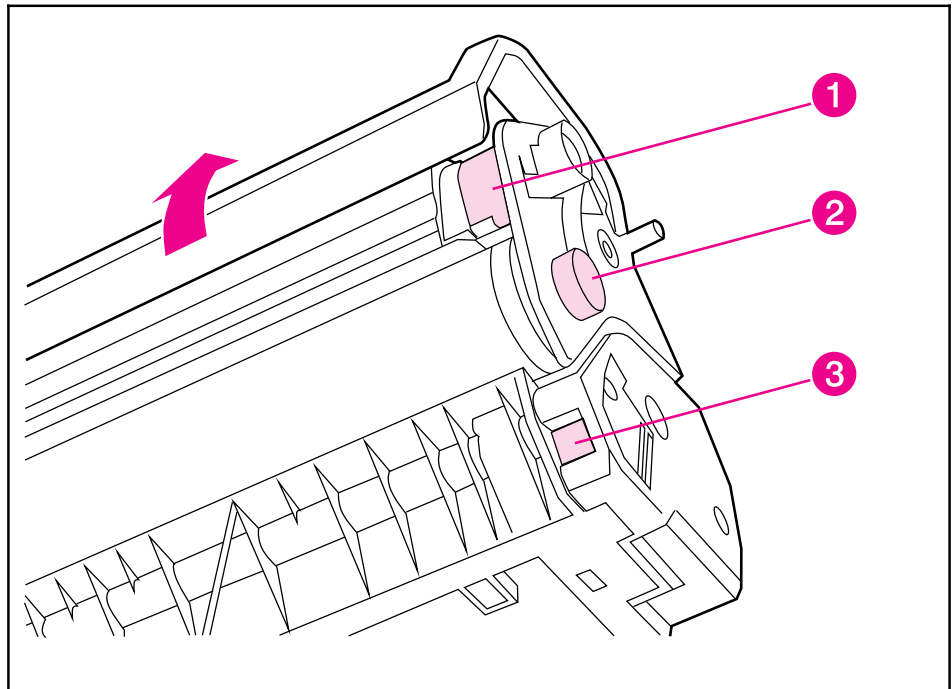

Toner Cartridge High Voltage Connection Points (1 of 2)

- Charging (1)
- Drum Ground (2)
- Developing Roller (3)

Figure 7-6

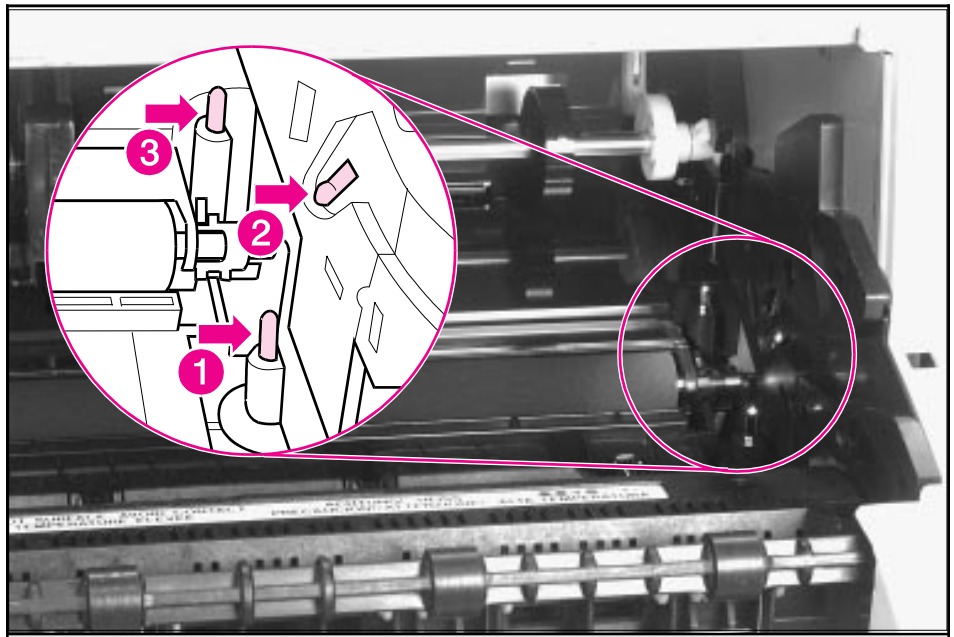

Toner Cartridge High Voltage Connection Points (2 of 2)

- Charging (1)
- Drum Ground (2)
- Developing Roller (3)

Paper Curl

Paper curl is inherent to the laser printing processes, and occurs when paper is subjected to heat. Paper curl tends to relax as the paper cools while resting on a flat surface. The specification for maximum paper curl when the paper is lying flat before print is 5 mm (0.2 inches).

Although paper curl cannot be totally eliminated, some steps can be taken to lessen its impact, as suggested in the following table.

Table 7-6

Paper Curl Troubleshooting

Possible Cause	Recommended Action
Paper Path	Try using the front output slot to shorten and straighten the paper path.
Paper Surface	The recommended printing surface of the page is usually marked on the end of a ream of paper by a small arrow and the phrase "print this side first." If the incorrect side was face up, turn the paper over. Load paper into the Paper Input Bin with the recommended printing surface facing the front of the printer.
Paper Storing and Handling	Over time, paper assumes the characteristics of its storage environment. (In a humid environment, paper absorbs moisture. In a dry environment, paper loses moisture.) Paper with higher moisture contents will tend to curl more. Evaluate the storage conditions of the paper.
Paper Type	All paper is manufactured differently (texture, moisture content, drying processes, composition, etc.). Change the type of paper being used and re-evaluate the paper if curl results.

Troubleshooting Tools

Paper Path Check

If paper is not being picked up or is not moving through the paper path, you may want to observe all of the paper motion activities. Overriding PS204 (5L) or SW101 (6L) allows you to observe:

- Motor rotation
- Solenoid action
- Kick plate motion
- Paper Pickup Roller motion
- Drive Roller, Transfer Roller, Fuser Roller and Gear, and Delivery Roller Motion.

To override PS204 and SW101

- 1 Remove the Printer Covers (Figures 6-2, 6-3, and 6-4).
- 2 **For HP LaserJet 5L Printer only:** Press the Door Open flag down (Figure 7-7, callout 1) and lift the EP Cartridge flag (Figure 7-7, callout 2). These flags are located on top of the printer chassis to the left of the Laser/Scanner assembly.
For both HP LaserJet 5L and 6L Printers: Press SW101 (Figure 7-7, callout 3).

Figure 7-7

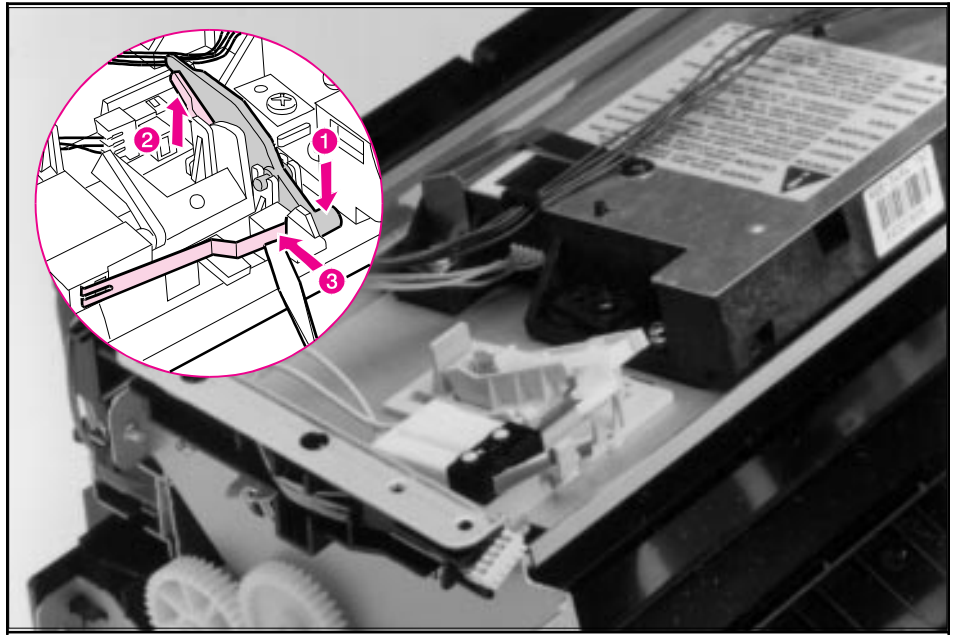

Overriding PS204 and SW101

- 3 While holding the flags up, perform either an Engine Test or a Self Test to observe paper motion. (See procedures earlier in this chapter.)

Repetitive Image Defect Ruler

Figure 7-8

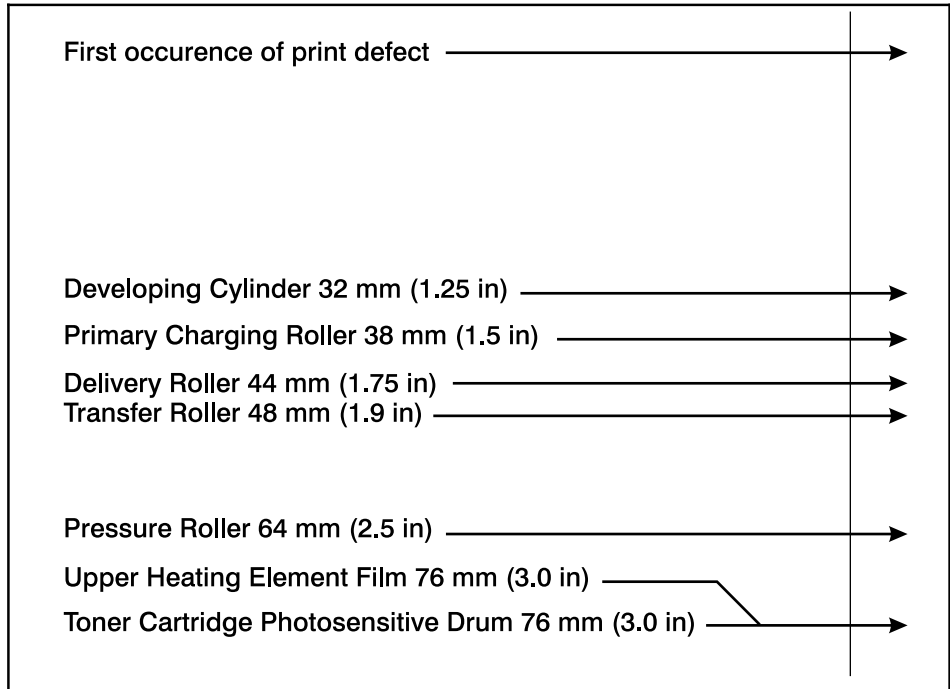

Repetitive Image Defect Ruler

Main Wiring Diagram

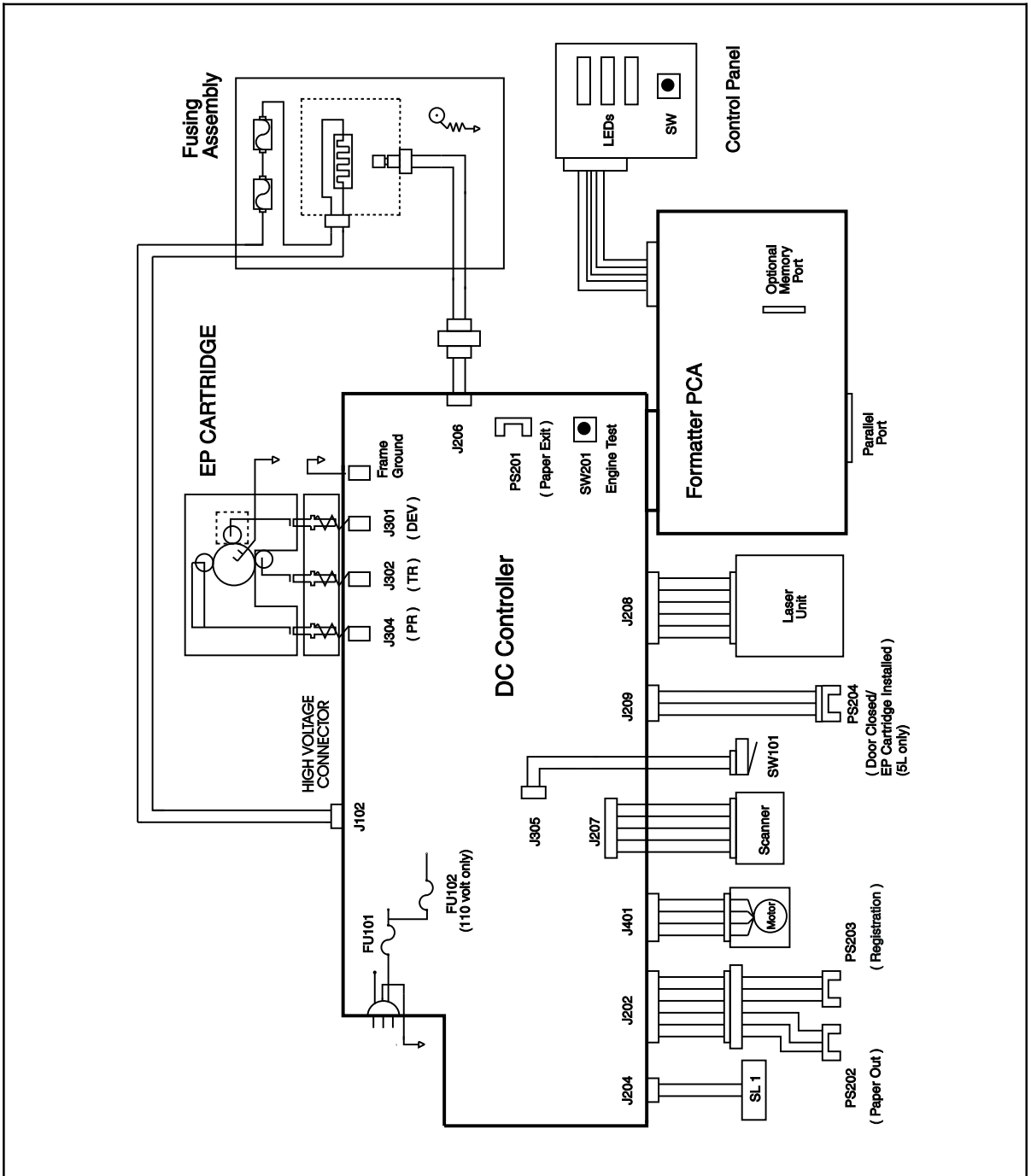

Figure 7-9 Main Wiring Diagram

Table 7-7

Cable Pinouts

Connector	Signal Name	Remarks
J401 pin 1	MA	Motor Drive Signal
J401 pin 2	/MA	Motor Drive Signal
J401 pin 3	MB	Motor Drive Signal
J401 pin 4	/MB	Motor Drive Signal
J204 pin 1	+12 V	5L only
J204 pin 2	CPUD	Solenoid SL1 Pickup Drive (5L only)
J202 pin 1	+5V	
J202 pin 2	GND	
J202 pin 3	PAPSENS	"L" when PS202 detects paper
J202 pin 4	+5V	
J202 pin 5	GND	
J202 pin 6	PISNS	"L" when PS203 detects paper
J207 pin 1	+12 V	
J207 pin 2	SCNTAC	Scanner tachometer pulses
J207 pin 3	FG	
J207 pin 4	/SCNON	"L" to rotate scanner motor
J207 pin 5	SCNCLK	Scanner clock reference
J208 pin 1	+5 V	
J208 pin 2	APCSH	APC sample hold
J208 pin 3	/LON	Laser Enable
J208 pin 4	FG	
J208 pin 5	/VDOUT	Laser Drive Signal
J208 pin 6	BDI	Beam Detect Input Signal
J209 pin 1	+5 V	
J209 pin 2	GND	

Table 7-8**Cable Pinouts**

Connector	Signal Name	Remarks
J209 pin 3	DOSNS	"H" when cartridge is not installed or the front door is open at PS204.
J305 pin 1	+12A V	
J305 pin 2	N/U	
J305 pin 3	+12 V	
J206 pin 1	FRSTH	Fusing temperature feedback
J206 pin 2	FG	
J102 pin 1		Fusing assembly drive voltage
J102 pin 2		Fusing assembly drive voltage

Parts and Diagrams

Contents

How to Use the Part Lists and Diagrams	8-3
Ordering Parts	8-3
Ordering Consumables	8-4
Accessories and Supplies	8-5
Common Hardware	8-6

How to Use the Part Lists and Diagrams

The Figures in this chapter illustrate the major subassemblies in the printer and their component parts. A table (material list) follows each exploded assembly diagram. Each table lists the reference designator (item number) for each part, the associated part number for the item, the quantity, and a description of the part.

While looking for a part number, pay careful attention to the voltage listed in the description column to ensure that the part number selected is for the correct model of printer.

Ordering Parts

All standard part numbers listed are stocked and may be ordered from HP's Support Materials Organization (SMO), or Support Materials Europe (SME).

Hewlett-Packard Co. Support Materials Organization 8050 Foothills Blvd. Roseville, CA 95678 Parts Direct Ordering: 1-800-227-8164 (U.S. Only)

Hewlett-Packard Co. Support Materials, Europe Wolf-Hirth Strasse 33 D-7030 Böblingen, Germany (49 7031) 14-2253

You can also contact HP at 916-783-0804 to find out part numbers for the LaserJet 5L and 6L. Contact your local HP Parts Coordinator for other local phone numbers.

Ordering Consumables

Consumables and accessories such as those listed on Table 8-1 may be ordered from Hewlett-Packard.

The phone numbers are:

U.S.: 1-800-538-8787 Canada: 1-800-387-3154 (Toronto) 516-671-8383 United Kingdom: 0734-441212 Germany: 0130-3322

Contact your local HP Parts Coordinator for other local phone numbers.

Note

Parts that have no reference designator or part number are not field replacement parts and cannot be ordered through SMO.

Accessories and Supplies

The following items are available through your local authorized HP dealer. To find a dealer near you (or if your dealer is temporarily out of stock), call the HP Customer Information Center (800) 752-0900.

Note

Refer to “Related Documentation” in Chapter 1 for documentation and training media product numbers.

Table 8-1

Accessories and Supplies

Item	Product Number	Description
Toner Cartridge	C3906A	Replacement toner cartridge.
Memory upgrades	1 MByte - C3939A 2 MByte - C3938A 4 MByte - C3148A	You can upgrade to a total of 9 MBytes of memory in the HP LaserJet 5L/6L.
Parallel cable (IEEE 1284)	C2950A	2 meter, A to B
	C2951A	3 meter, A to B

Note

You can upgrade to a total of 9 Mbytes of memory with an 8 Mbyte JEDIA memory module (not currently available from HP).

Common Hardware

Table 8-2

Common Fasteners Used in the Printer

Example	Description
	Screw, Machine, Trus Head M3x4, M3x6, M3x8
	Screw, Star, 3x6
	Screw, Self-tap, 4x10
	Screw, Hex-head, 3x8
	Screw, Hexhead, 3x6,m 3x8, 3x10

Figure 8-1



Major Assembly Locations

Figure 8-2

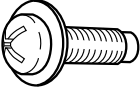
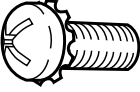
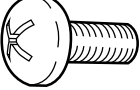
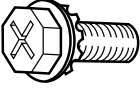
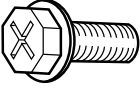
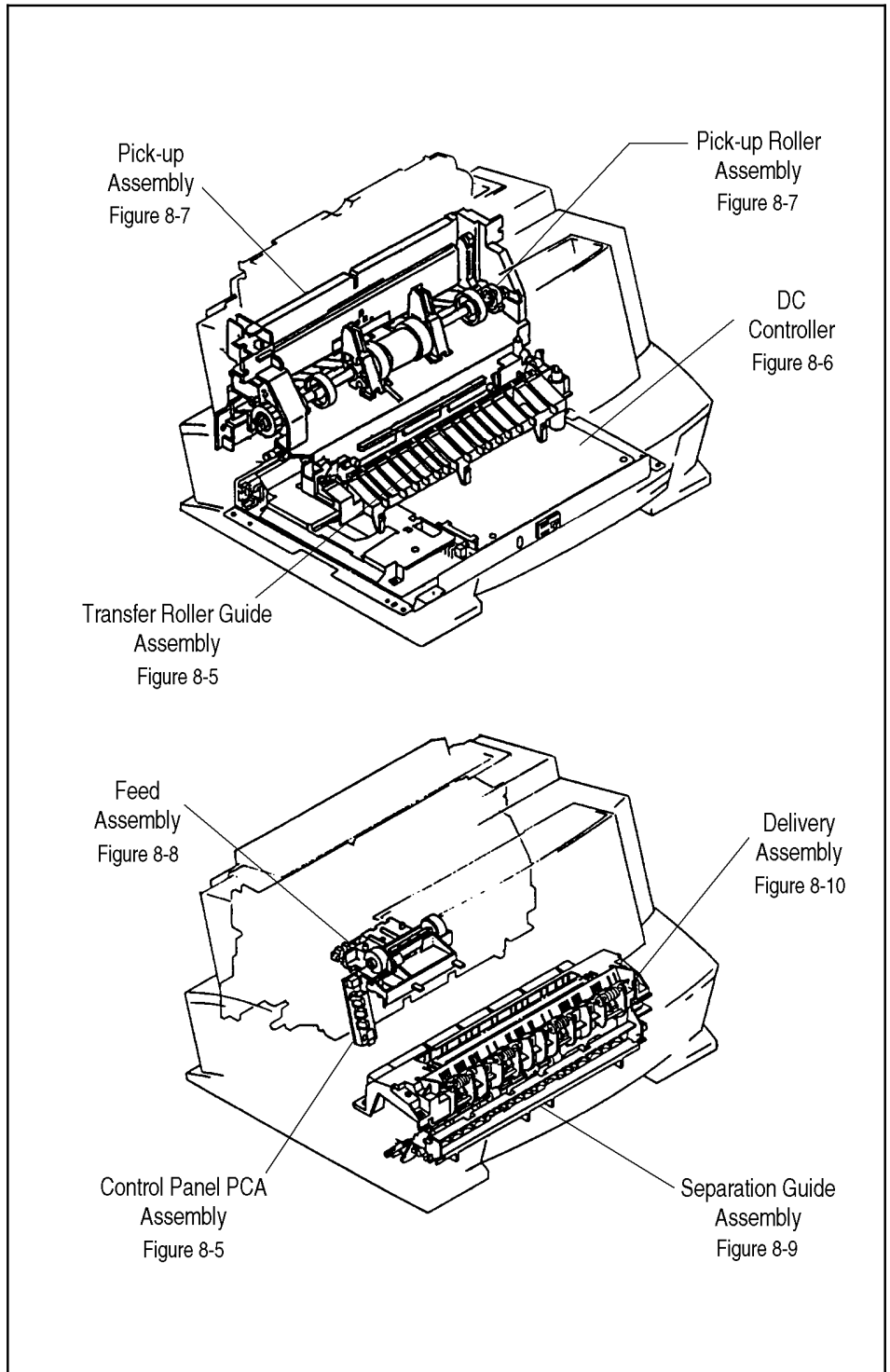
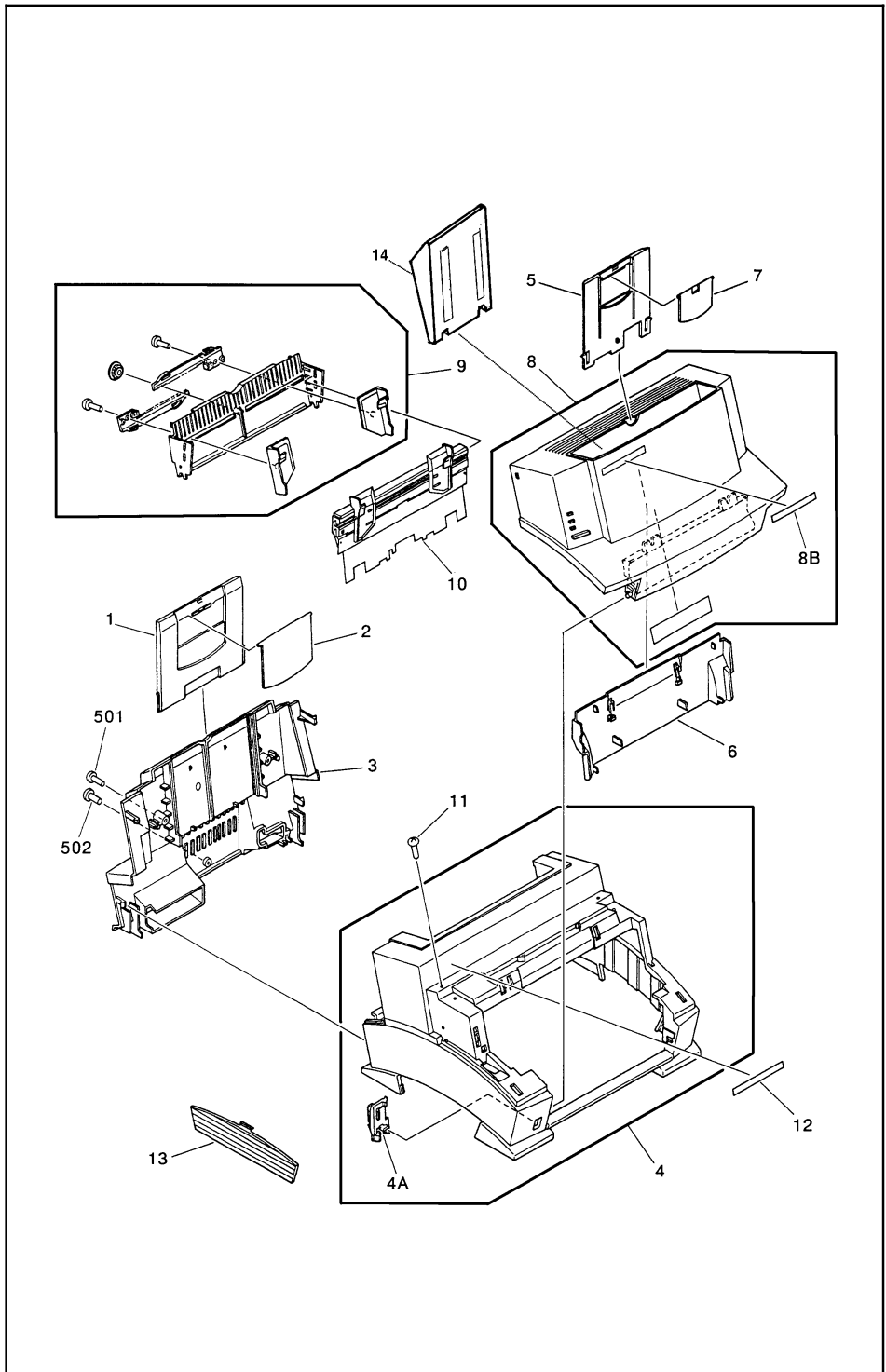

Covers and Doors

Table 8-3

Covers and Doors

Ref	LaserJet 5L Part No.	LaserJet 6L Part No.	Qty	Description
1	RB1-7211-000CN	RB2-1637-000CN	1	Input Extender 1
2	RB1-7212-000CN	RB2-1638-000CN	1	Input Extender 2
3	RB1-7333-000CN	RB2-1636-000CN	1	Back Cover
4	RG5-1995-000CN	RG5-3443-000CN	1	Main Cover
4A	RB1-7278-000CN	RB2-1644-000CN	1	Face-up/Face-down Switch
5	RB1-7326-000CN	RB2-1695-000CN	1	Output Extender 1
6	RB1-7327-000CN	RB2-1697-000CN	1	EP Door Chimney
7	RB1-7331-000CN	RB2-1696-000CN	1	Output Extender 2
8	RF5-1501-030CN	RF5-2352-000CN	1	EP Door Assembly
8B	RB1-7335-000CN	RB2-1641-000CN	1	Nameplate
9	RG5-1944-000CN	RG5-3488-000CN	1	Input Assembly 1
10	RG5-1945-000CN	RG5-3491-000CN	1	Input Assembly 2
11	XA9-0724-000CN	XA9-0724-000CN	2	Screw RS, M3x8
13	RB1-7321-000CN	RB2-1639-000CN	1	Memory Door
14	RB1-7332-000CN	n/a	1	Output Tray Fin
501	XB4-7401-007CN	XB4-7401-007CN	2	Screw, Tp, PH, M4x10
502	XB6-7300-807CN	XA9-0267-000CN	2	Screw, Tp, M3x8

Figure 8-3

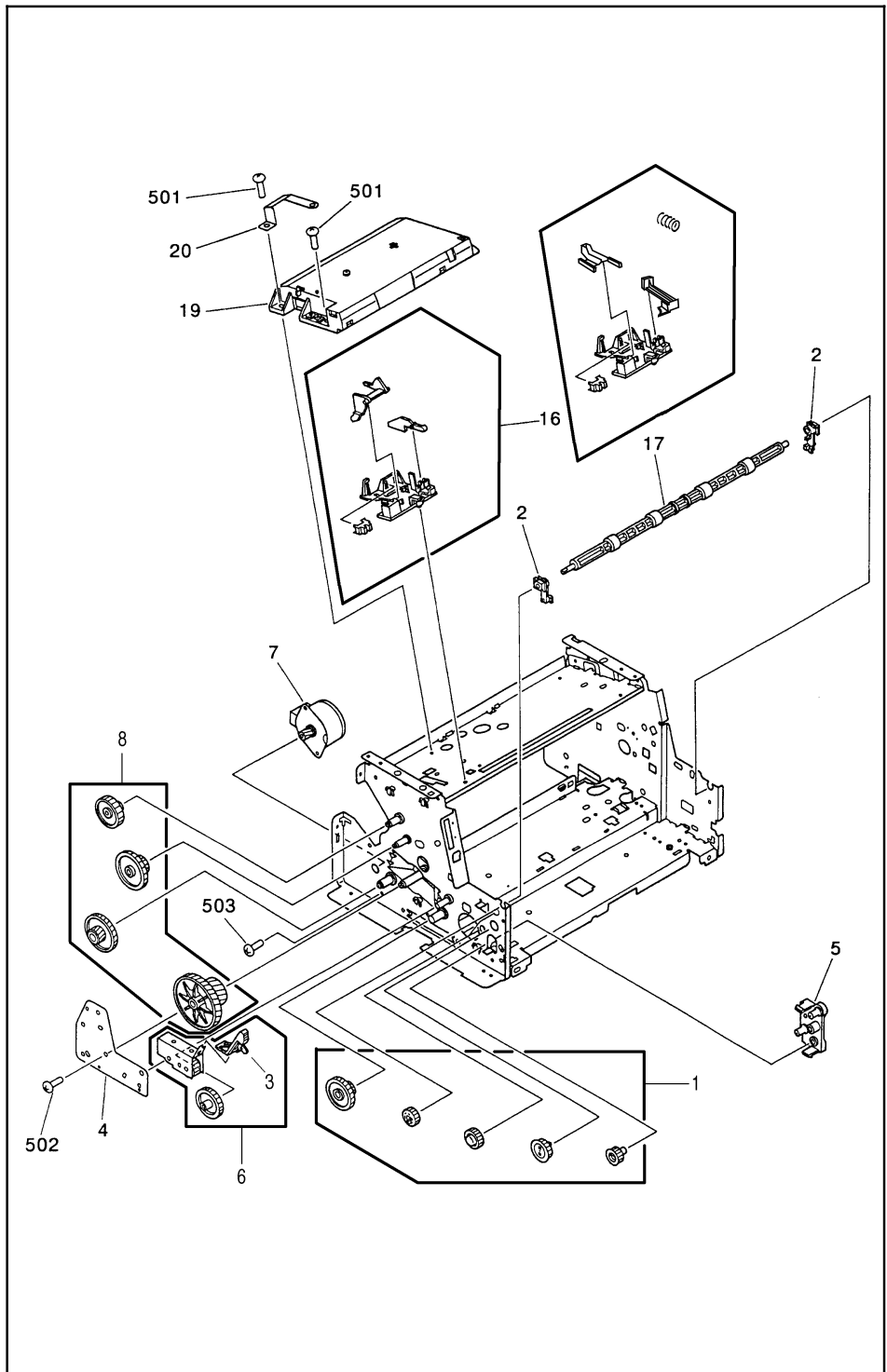

Internal Components (1 of 3)

Table 8-4

Internal Components (1 of 3)

Ref	LaserJet 5L Part No.	LaserJet 6L Part No.	Qty	Description
1	RY7-5005-000CN	RY7-5005-000CN	1	Gear Kit #1
2	RB1-7288-000CN	RB1-7288-000CN	2	Exit Roller Bushing
3	RB1-7105-000CN	RB1-7105-000CN	1	Fuser Release Tab
4	RB1-7106-000CN	RB2-1632-000CN	1	Gear Plate
5	RB1-7107-000CN	RB1-7107-000CN	1	Front Gear Case
6	RY7-5007-000CN	RY7-5007-000CN	1	Fuser Release Kit
7	RH7-1282-000CN	RH7-1320-000CN	1	Main Motor
8	RY7-5006-000CN	RY7-5036-000CN	1	Gear Kit #2
16	RG5-1984-000CN	RG5-3453-000CN	1	EP/Cover Interlock
17	RF5-1521-000CN	RF5-2367-000CN	1	Exit Roller
19	RG5-2000-000CN	RG5-3494-000CN	1	Laser/Scanner
19	C3941-69003	n/a		Laser/Scanner Exchange
20	RB1-7385-000CN	RB1-7385-000CN	1	Ground Clip, Scanner
501	XB6-7300-807CN	XB6-7300-807CN	4	Screw, TP, M3x8
502	XB6-7300-607CN	XB6-7300-607CN	4	Screw, TP, M3x6
503	XA9-0267-000CN	XA9-0267-000CN	2	Screw, TP, M3x6

Figure 8-4

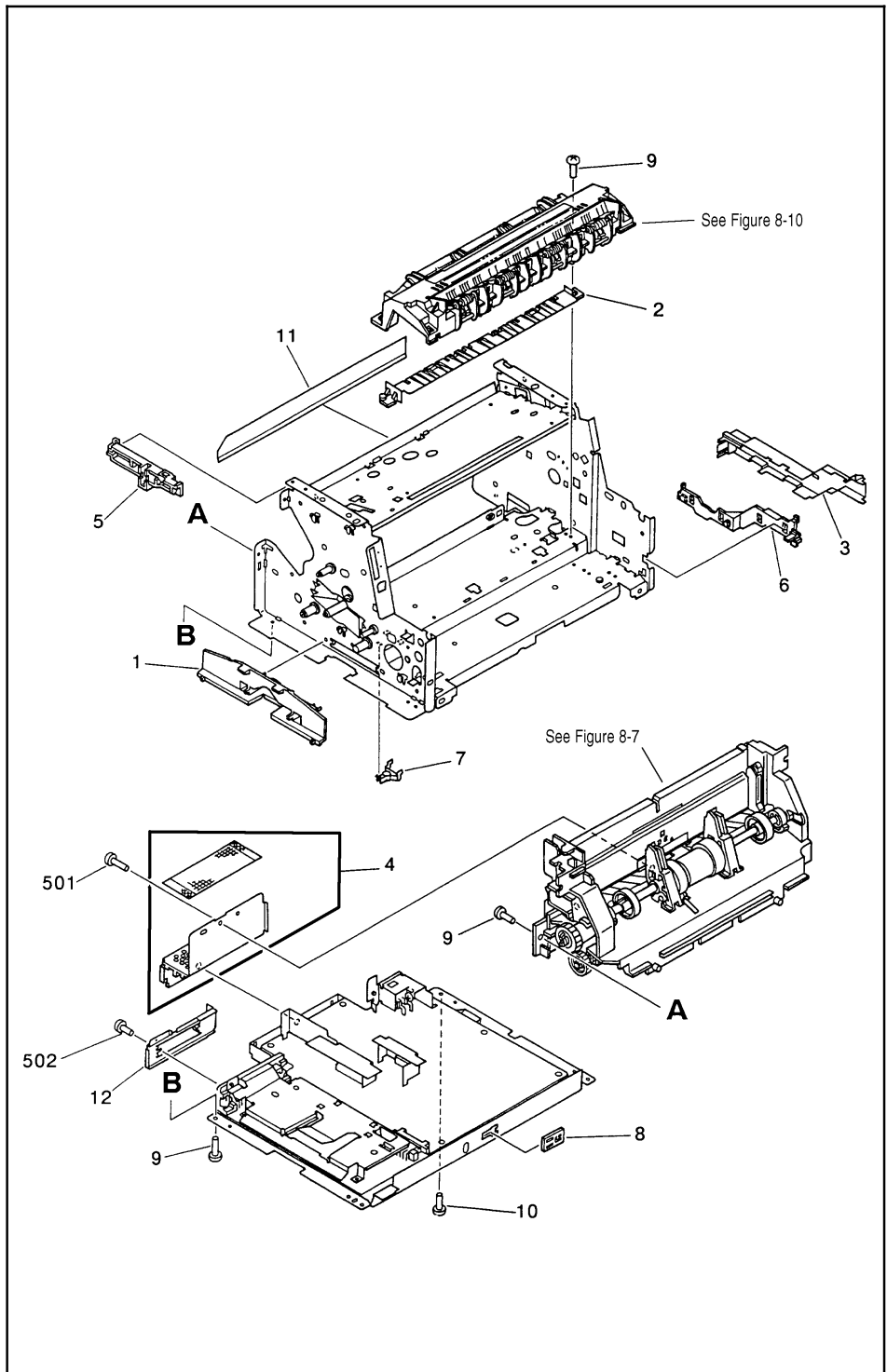

Internal Components (2 of 3)

Table 8-5

Internal Components (2 of 3)

Ref	LaserJet 5LPart No.	LaserJet 6LPart No.	Qty	Description
1	RB1-7109-000CN	RB1-7109-000CN	1	Memory Door Guide
2	RB1-7247-000CN	RB1-7247-000CN	1	Fuser Paper Guide
3	RB1-7344-000CN	RB1-7344-000CN	1	AC Cable Cover
4	RF5-1509-000CN	RF5-1509-000CN	1	Back Sheet Metal
5	RB1-7343-000CN	RB1-7343-000CN	1	Control Panel Cable Guide
6	RB1-7130-000CN	RB1-7130-000CN	1	Fuser Cable Guide
7	RB1-7234-000CN	RB1-7234-000CN	1	Cap
8	RB1-7302-000CN	RB1-7302-000CN	1	Cap
9	XA9-0724-000CN	XA9-0724-000CN	6	Screw, RS, M3x8
10	XA9-0855-000CN	XA9-0855-000CN	2	Screw, RS, M3x8 (with star washer)
11	RB1-7176-000CN	RB1-7176-000CN	1	Mylar Guide
12	RB1-7305-000CN	RB1-7305-000CN	1	I/O Sheet Metal
501	XB4-7401-007CN	XB4-7401-007CN	3	Screw, Tapping, Panhead, M4x10
502	XB1-1300-807CN	XB1-1300-807CN	2	Screw, PH, M3x8

Figure 8-5

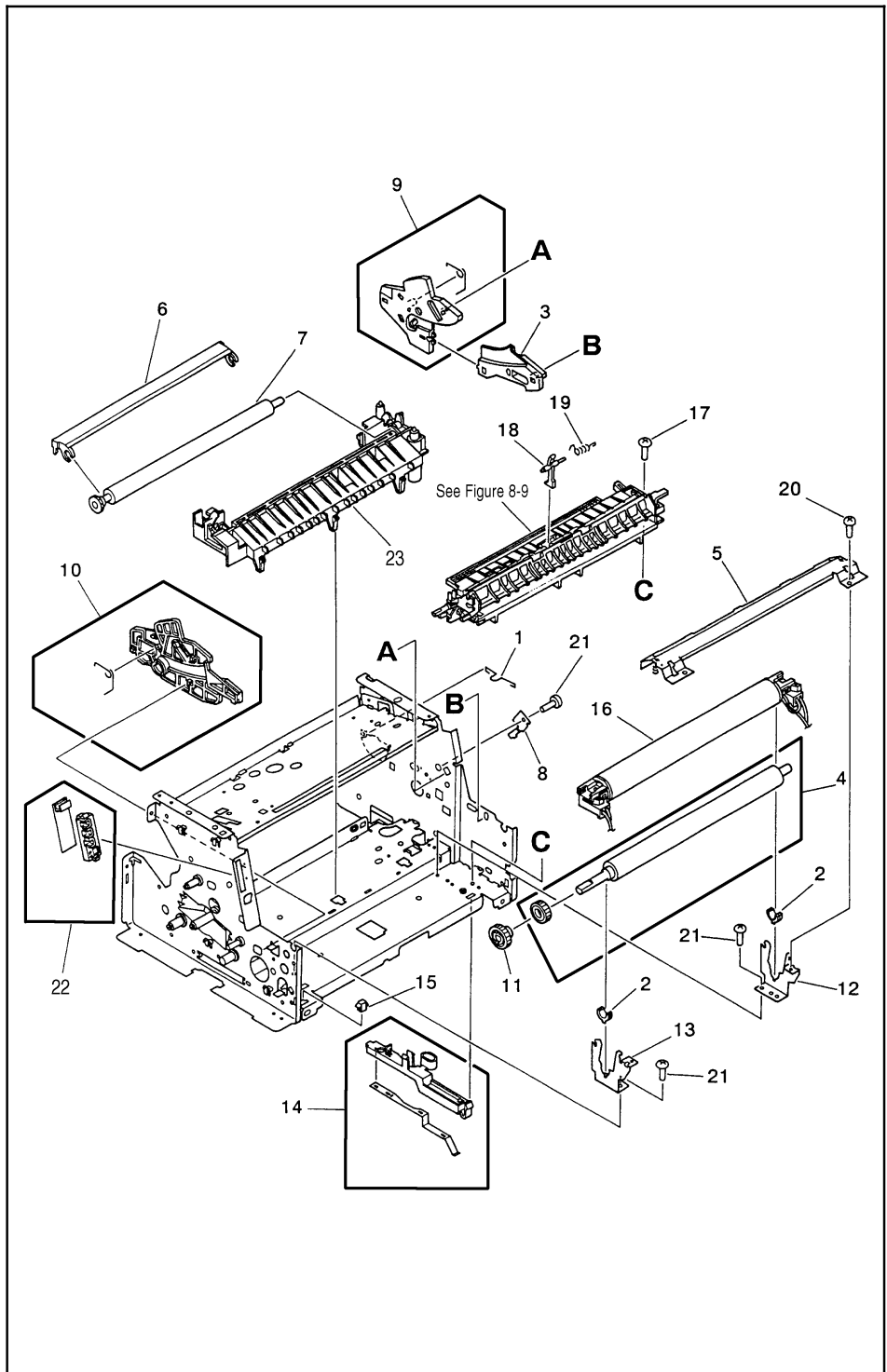

Internal Components (3 of 3)

Table 8-6

Internal Components (3 of 3)

Ref	LaserJet 5LPart No.	LaserJet 6LPart No.	Qty	Description
1	RB1-7223-000CN	RB1-7223-000CN	1	Pickup Roller Grounding Clip
2	RB1-7246-000CN	RB1-7246-000CN	2	Pressure Roller Bushing
3	RB1-7341-000CN	RB1-7341-000CN	1	EP Right Hand Guide #2
4	RF5-1516-000CN	RF5-2362-000CN	1	Pressure Roller
5	RF5-1517-000CN	RF5-1517-000CN	1	Fuser Pressure Plate
6	RF5-1530-000CN	RF5-2358-000CN	1	Transfer Roller Guide
7	RF5-1534-000CN	RF5-1534-000CN	1	Transfer Roller
8	RB1-7129-000CN	RB1-7129-000CN	1	Case Ground Metal
9	RF5-1515-000CN	RF5-1515-000CN	1	EP Right Hand Guide #1
10	RF5-1514-000CN	RF5-1514-000CN	1	EP Left Hand Guide
11	RS5-0796-000CN	RS5-0796-000CN	1	Pressure Roller Gear
12	RB1-7256-000CN	RB1-7256-000CN	1	Right Pressure Roller Housing
13	RB1-7255-000CN	RB1-7255-000CN	1	Left Pressure Roller Housing
14	RF5-1533-000CN	RF5-1533-000CN	1	Pressure Roller Ground Guide
15	VS1-5057-002CN	VS1-5057-002CN	1	Fuser Connector
16	RG5-1964-000CN	RG5-3459-000CN	1	Heating Element (110v)
16	RG5-1965-000CN	RG5-3463-000CN	1	Heating Element (220v)
17	XA9-0824-000CN	XA9-0824-000CN	1	Screw, RS, M3x10
18	RB1-7293-000CN	RB1-7293-000CN	1	Flag
19	RB1-7294-000CN	RB1-7294-000CN	1	Flag Spring
20	XA9-0724-000CN	XA9-0724-000CN	2	Screw, RS,, M3x8
21	XA9-0686-000CN	XA9-0686-000CN	14	Screw, RS, M3x6
22	RG5-2028-000CN	RG5-2028-000CN	1	Control Panel PCA Assembly
23	RG5-1961-000CN	RG5-3452-000CN	1	Transfer Guide Assembly
	CK-8006	CK-8006	1	Pressure Roller Grease

Figure 8-6

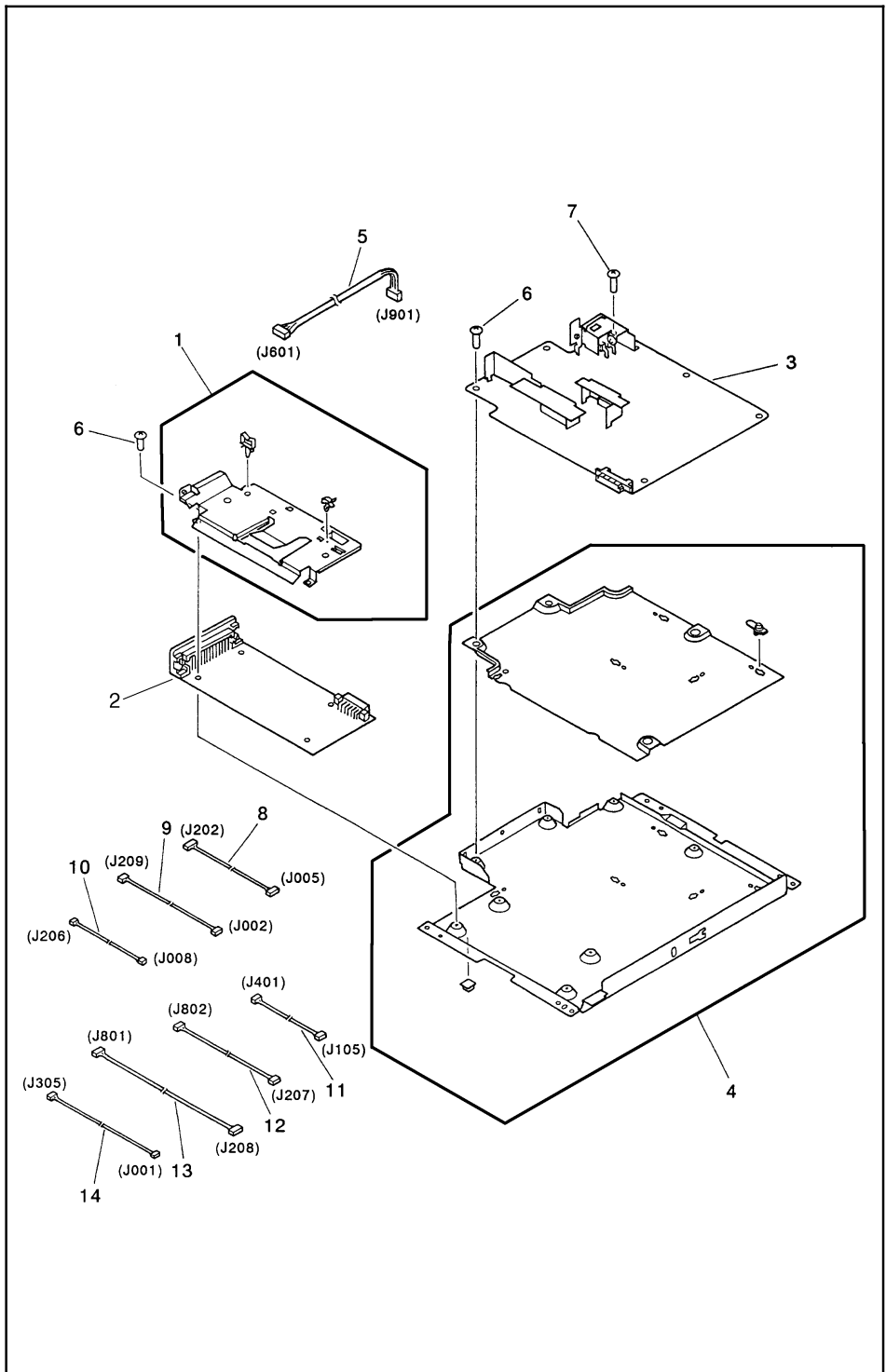

DC Controller/Formatter and Cables

Table 8-7

DC Controller Case

Ref	LaserJet 5L Part No.	LaserJet 6L Part No.	Qty	Description
1	RG5-2024-000CN	RB2-1719-000CN	1	Formatter Shield
2	C3942-67902	C3991-60001	1	Formatter, New
	C3942-69002	n/a	1	Formatter, Exchange
3	RG5-2023-000CN	RG5-3506-000CN	1	DC Controller PCA (110 V)
3	RG5-2025-000CN	RG5-3509-000CN	1	DC Controller PCA (220 V)
3	C3941-69001	n/a		DC Controller PCA (110 V) Exchange
3	C3941-69002	n/a		DC Controller PCA (220 V) Exchange
4	RG5-3510-000CN	RG5-3510-000CN	1	DC Controller PCA Case Assembly
5	RG5-2036-000CN	RG5-3499-000CN	1	Control Panel PCA Cable
6	XA9-0326-000CN	XA9-0890-000CN	9	Screw, TP, M3x4
7	XA9-0828-000CN	XA9-0828-000CN	1	Screw, WStar
8	RG5-2029-000CN	RG5-2029-000CN	1	Paper Pickup Cable
9	RG5-2031-000CN	RG5-3662-000CN	1	Door Sensor Cable
10	RG5-2032-000CN	RG5-2032-000CN	1	Thermistor Cable
11	RG5-2033-000CN	RG5-2033-000CN	1	Motor Cable
12	RG5-2034-000CN	RG5-3661-000CN	1	Scanner Cable
13	RG5-2035-000CN	n/a	1	Laser Cable
14	RG5-2037-000CN	n/a	1	Door Switch Cable
	VD7-0211-002CN	VD7-0211-002CN	1	Fuse 101 (110 V)
	VD7-0643-151CN	VD7-0643-151CN	1	Fuse 101 (220 V)
	RH3-8003-000CN	RH3-8003-000CN	1	Fuse 102 (110 V)

Figure 8-7

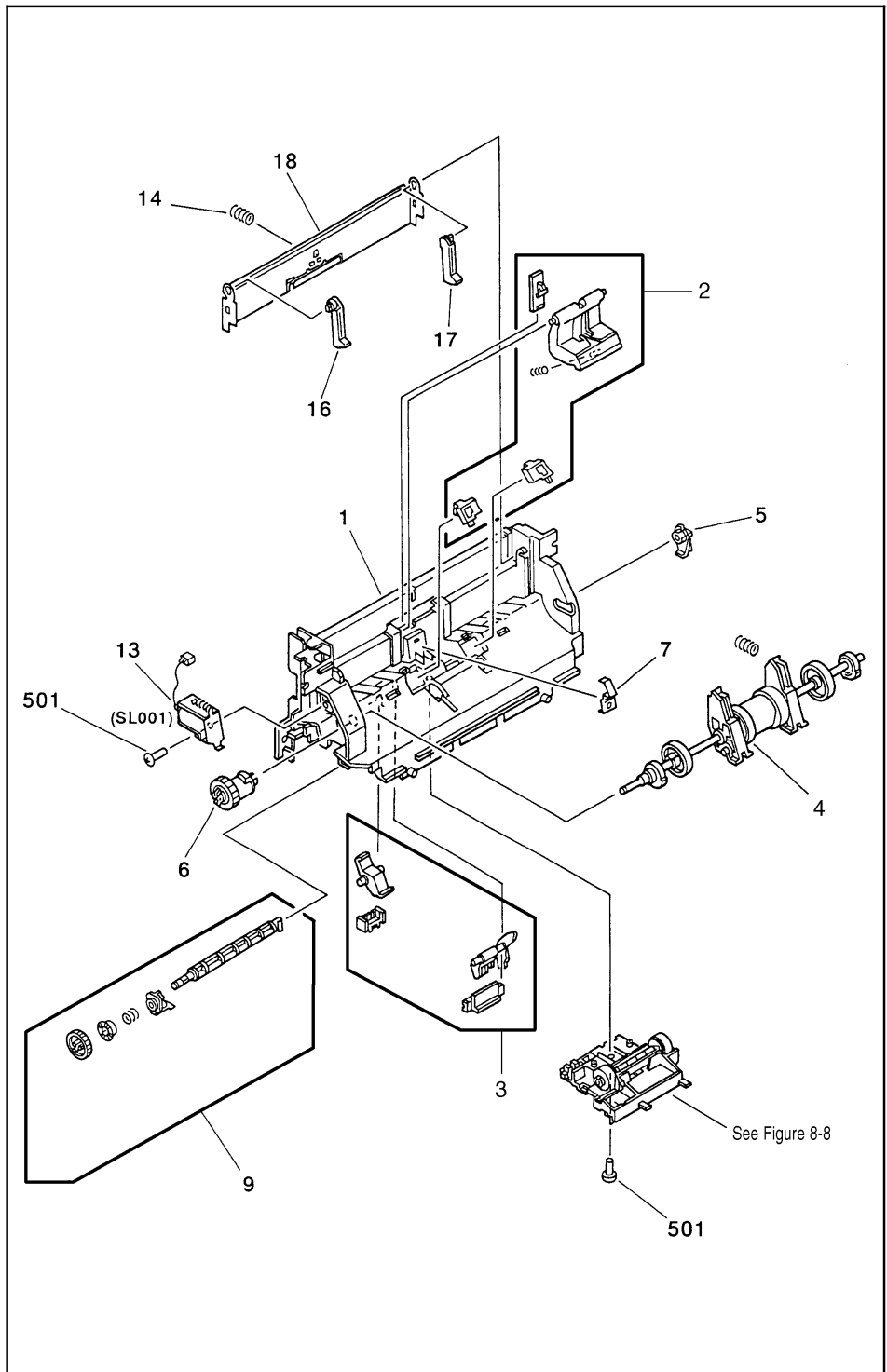

Pickup Roller Assembly

Table 8-8

Ref	LaserJet 5L Part No.	LaserJet 6L Part No.	Qty	Description
1	RB1-7177-000CN	RB1-7177-000CN	1	Paper Feed Frame
2	RY7-5008-000CN	RY7-5008-000CN	1	Separation Pad Assembly
3	RY7-5009-000CN	RY7-5009-000CN	1	Input Sensor Assembly
4	RG5-1951-000CN	RG5-3486-000CN	1	Pickup Roller Assembly
5	RB1-7184-000CN	RB1-7184-000CN	1	Pickup Roller Bushing
6	RB1-7197-000CN	RB1-7197-000CN	1	Clutch
7	RB1-7199-000CN	RB1-7199-000CN	1	Back Grounding Clip
9	RG5-1947-000CN	RG5-1947-000CN	1	Idler Roller Shaft Assembly
13	RH7-5139-000CN	RH7-5139-000CN	1	Solenoid
14	RS5-2501-000CN	RS5-2501-000CN	1	Kick Plate Spring
16	RB1-7185-000CN	RB1-7185-000CN	1	Left Leg
17	RB1-7186-000CN	RB1-7186-000CN	1	Right Leg
18	RF5-1490-000CN	RF5-2372-000CN	1	Paper Kick Plate
501	XB4-7401-0007	XB4-7401-0007	2	Screw, TP, PH, M4x10

Figure 8-8

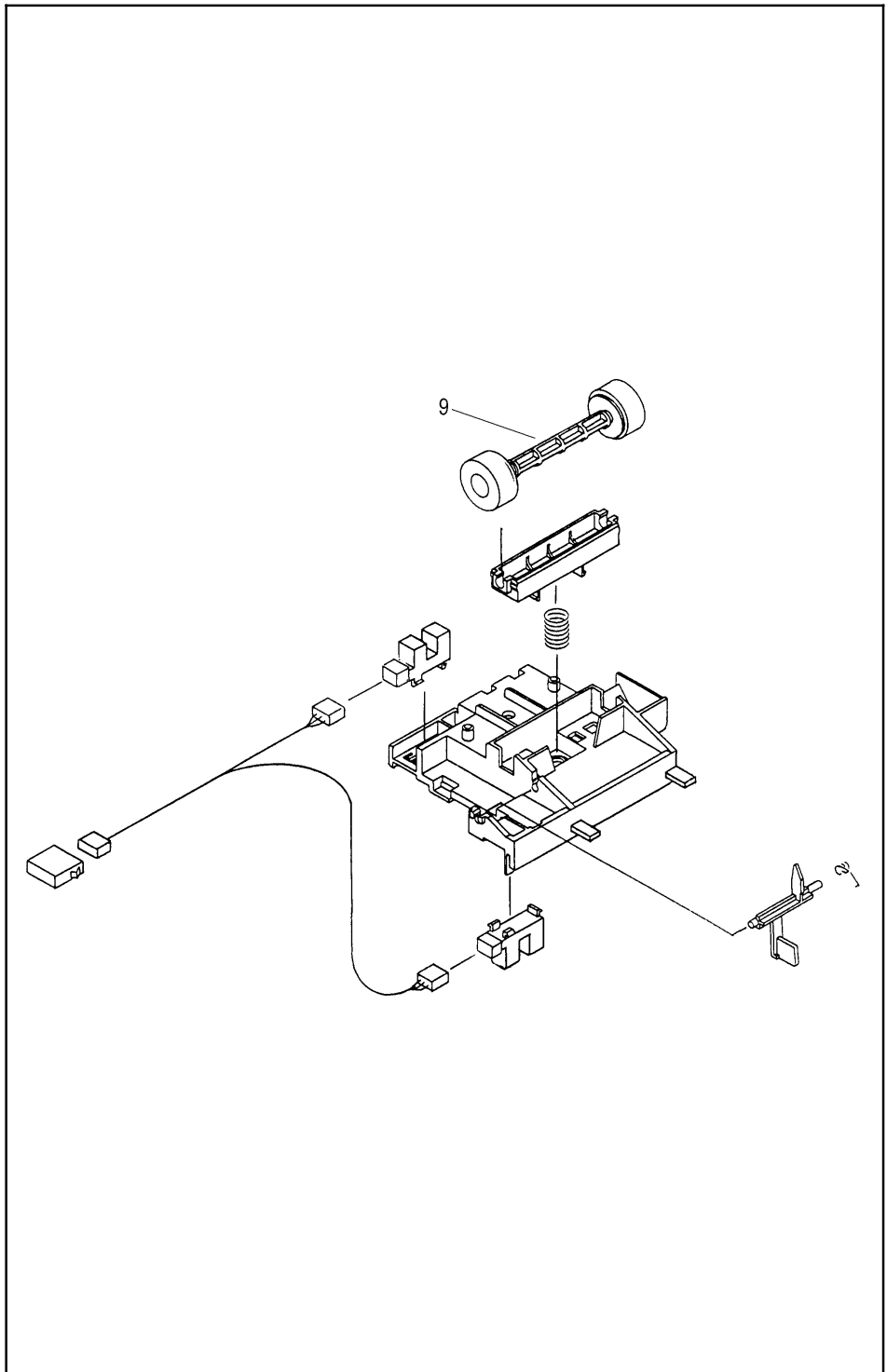

Feed Assembly

Table 8-9

Ref	LaserJet 5L Part No.	LaserJet 6L Part No.	Qty	Description
	RG5-1942-000CN	RG5-3485-000CN	1	Feed Assembly
9	RB1-7226-000CN	RB2-1699-000CN	1	Idler Roller

Figure 8-9

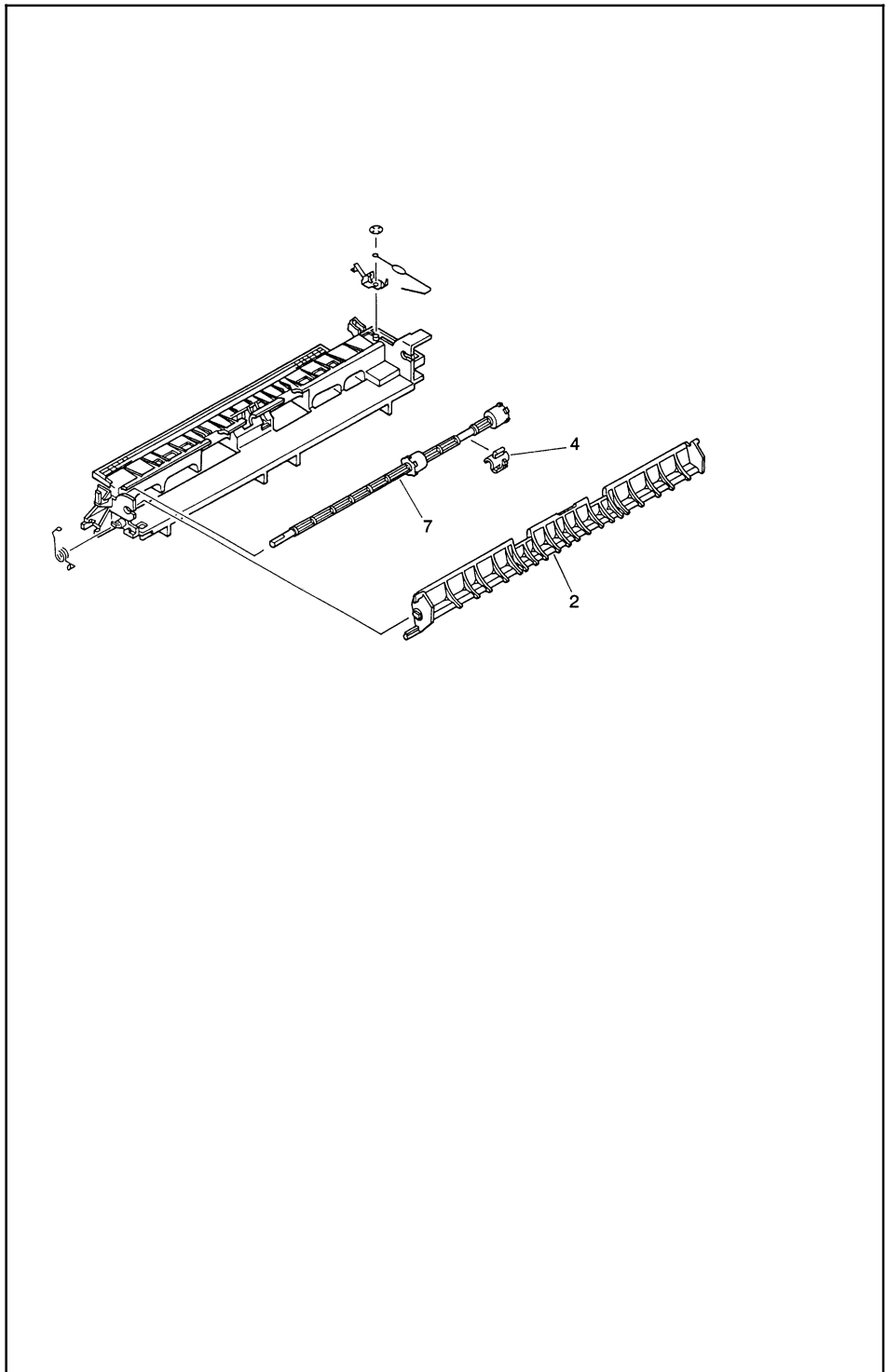

Separation Guide Assembly

Table 8-10

Ref	LaserJet 5L Part No.	LaserJet 6L Part No.	Qty	Description
	RG5-2013-000CN	RG5-3475-000CN	1	Separation Guide Assembly
2	RB1-7276-000CN	RG5-3476-000CN	1	Face-Up/Face-Down Lever
4	RB1-7289-000CN	RB2-1690-000CN	1	Fuser Roller Bushing
7	RF5-1522-000CN	RF5-2368-000CN	1	Fuser Exit Roller Assembly

Figure 8-10

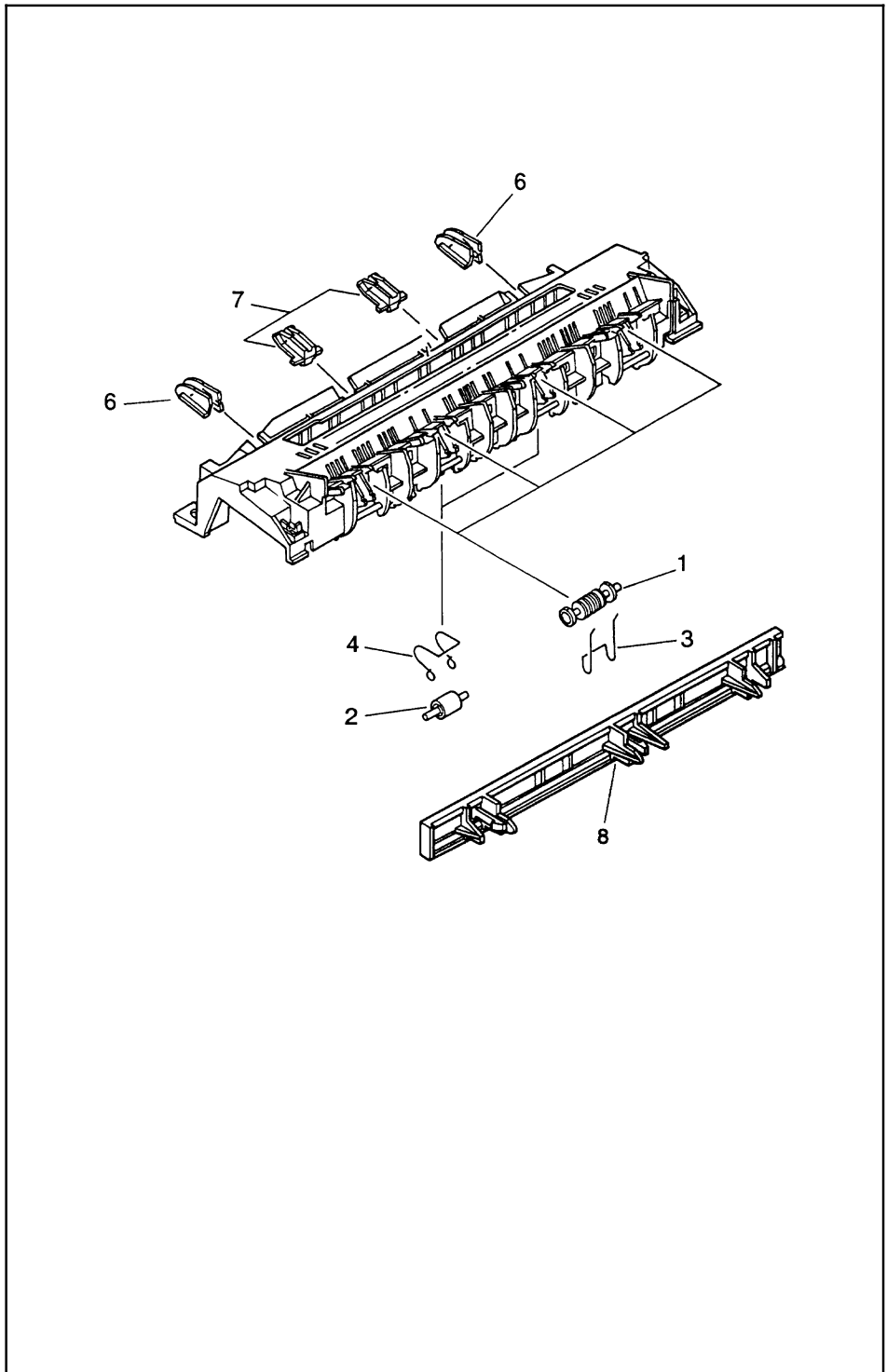

Delivery Assembly

Table 8-11

Ref	LaserJet 5L Part No.	LaserJet 6L Part No.	Qty	Description
	RG5-2012-000CN	RG5-3474-000CN	1	Delivery Assembly
1	RB1-7284-000CN	RB1-7284-000CN	4	Delivery Roller #1
2	RB1-7285-000CN	RB2-1685-000CN	2	Delivery Roller #2
3	RB1-7286-000CN	RB1-7286-000CN	4	Delivery Spring#1
4	RB1-7287-000CN	RB1-7287-000CN	2	Delivery Spring#2
6	RG5-2015-000CN	RG5-3479-000CN	2	Spur Assembly Outside
7	RG5-2014-000CN	RG5-3478-000CN	2	Spur Assembly Inside
8	RB1-7334-000CN	RB1-7334-000CN	1	JP Protector

Parts Index

Parts Index

Table A-1

Alphabetical Parts List

Description	Part No.	Fig.	Ref.
AC Cable Cover	RB1-7344-000CN	8-4	3
Back Cover (5L)	RB1-7333-000CN	8-2	3
Back Cover (6L)	RB2-1636-000CN	8-2	3
Back Grounding Clip	RB1-7199-000CN	8-7	7
Back Sheet Metal	RF5-1509-000CN	8-4	4
Cap	RB1-7234-000CN	8-4	7
Cap	RB1-7302-000CN	8-4	8
Case Grounding Metal	RB1-7129-000CN	8-5	8
Clutch	RB1-7197-000CN	8-7	6
Control Panel Cable Guide	RB1-7343-000CN	8-4	5
Control Panel PCA Assembly	RG5-2028-000CN	8-5	22
Control Panel PCA Cable (5L)	RG5-2036-000CN	8-6	5
Control Panel PCA Cable (6L)	RG5-3499-000CN	8-6	5
DC Controller Fuse FU101-110 V	VD7-0211-002CN	8-6	
DC Controller Fuse FU101-220 V	VD7-0643-151CN	8-6	
DC Controller Fuse FU102-110 V	RH3-8003-000CN	8-6	
DC Controller PCA (110 V) (5L)	RG5-2023-000CN	8-6	3
DC Controller PCA (110 V) (6L)	RG5-3506-000CN	8-6	3
DC Controller PCA (110 V) Exchange (5L)	C3941-69001	8-6	3
DC Controller PCA (220 V) (5L)	RG5-2025-000CN	8-6	3
DC Controller PCA (220 V) (6L)	RG5-3509-000CN	8-6	3
DC Controller PCA (220 V) Exchange (5L)	C3941-69002	8-6	3
DC Controller PCA Case Assembly	RG5-3510-000CN	8-6	4
Delivery Assembly (5L)	RG5-2012-000CN	8-10	
Delivery Assembly (6L)	RG5-3474-000CN	8-10	
Delivery Roller #1	RB1-7284-000CN	8-10	1
Delivery Roller #2 (5L)	RB1-7285-000CN	8-10	2
Delivery Roller #2 (6L)	RB2-1685-000CN	8-10	2
Delivery Spring #1	RB1-7286-000CN	8-10	3
Delivery Spring #2	RB1-7287-000CN	8-10	4
Door Sensor Cable (5L)	RG5-2031-000CN	8-6	9
Door Sensor Cable (6L)	RG5-3662-000CN	8-6	9

Table A-1

Alphabetical Parts List (continued)

Description	Part No.	Fig.	Ref.
Door Switch Cable (5L)	RG5-2037-000CN	8-6	14
EP Door Assembly (5L)	RF5-1501-030CN	8-2	8
EP Door Assembly (6L)	RF5-2352-000CN	8-2	8
EP Door Chimney (5L)	RB1-7327-000CN	8-2	6
EP Door Chimney (6L)	RB2-1697-000CN	8-2	6
EP Left Hand Guide	RF5-1514-000CN	8-5	10
EP Right Hand Guide #1	RF5-1515-000CN	8-5	9
EP Right Hand Guide #2	RB1-7341-000CN	8-5	3
EP/Cover Interlock (5L)	RG5-1984-000CN	8-3	16
EP/Cover Interlock (6L)	RG5-3453-000CN	8-3	16
Exit Roller (5L)	RF5-1521-000CN	8-3	17
Exit Roller (6L)	RF5-2367-000CN	8-3	17
Exit Roller Bushing	RB1-7288-000CN	8-3	2
Face-up/Face-down Shaft (5L)	RB1-7276-000CN	8-9	2
Face-up/Face-down Shaft (6L)	RG5-3476-000CN	8-9	2
Face-up/Face-down Switch (5L)	RB1-7278-000CN	8-2	4A
Face-up/Face-down Switch (6L)	RB2-1644-000CN	8-2	4A
Feed Assembly (5L)	RG5-1942-000CN	8-8	
Feed Assembly (6L)	RG5-3485-000CN	8-8	
Flag	RB1-7293-000CN	8-5	18
Flag Spring	RB1-7294-000CN	8-5	19
Formatter Shield (5L)	RG5-2024-000CN	8-6	1
Formatter Shield (6L)	RB2-1719-000CN	8-6	1
Formatter (Exchange) (5L)	C3942-69002	8-6	2
Formatter (New) (5L)	C3942-67902	8-6	2
Formatter (New) (6L)	C3991-60001	8-6	2
Front Gear Case	RB1-7107-000CN	8-3	5
Fuse 101 (110 V)	VD7-0211-002CN	8-6	
Fuse 101 (220 V)	VD7-0643-151CN	8-6	
Fuse 102 (110 V)	RH3-8003-000CN	8-6	
Fuser Cable Guide	RB1-7130-000CN	8-4	6
Fuser Connector	VS1-5057-002CN	8-5	15
Fuser Exit Roller Assembly (5L)	RF5-1522-000CN	8-9	7
Fuser Exit Roller Assembly (6L)	RF5-2368-000CN	8-9	7
Fuser Paper Guide	RB1-7247-000CN	8-4	2

Table A-1

Alphabetical Parts List (continued)

Description	Part No.	Fig.	Ref.
Fuser Pressure Plate	RF5-1517-000CN	8-5	5
Fuser Release Kit	RY7-5007-000CN	8-3	6
Fuser Release Tab	RB1-7105-000CN	8-3	3
Fuser Roller Bushing (5L)	RB1-7289-000CN	8-9	4
Fuser Roller Bushing (6L)	RB2-1690-000CN	8-9	4
Gear Kit #1	RY7-5005-000CN	8-3	1
Gear Kit #2 (5L)	RY7-5006-000CN	8-3	8
Gear Kit #2 (6L)	RY7-5036-000CN	8-3	8
Gear Plate (5L)	RB1-7106-000CN	8-3	4
Gear Plate (6L)	RB2-1632-000CN	8-3	4
Ground Clip, Scanner	RB1-7385-000CN	8-3	20
Heating Element (110 V) (5L)	RG5-1964-000CN	8-5	16
Heating Element (110 V) (6L)	RG5-3459-000CN	8-5	16
Heating Element (220 V) (5L)	RG5-1965-000CN	8-5	16
Heating Element (220 V) (6L)	RG5-3463-000CN	8-5	16
I/O Sheet Metal	RB1-7305-000CN	8-4	12
Idler Roller (5L)	RB1-7226-000CN	8-8	9
Idler Roller (6L)	RB2-1699-000CN	8-8	9
Idler Roller Shaft Assembly	RG5-1947-000CN	8-7	9
Input Assembly 1 (5L)	RG5-1944-000CN	8-2	9
Input Assembly 1 (6L)	RG5-3488-000CN	8-2	9
Input Assembly 2 (5L)	RG5-1945-000CN	8-2	10
Input Assembly 2 (6L)	RG5-3491-000CN	8-2	10
Input Extender 1 (5L)	RB1-7211-000CN	8-2	1
Input Extender 1 (6L)	RB2-1637-000CN	8-2	1
Input Extender 2 (5L)	RB1-7212-000CN	8-2	2
Input Extender 2 (6L)	RB2-1638-000CN	8-2	2
Input Sensor Assembly	RY7-5009-000CN	8-7	3
JP Protector	RB1-7334-000CN	8-10	8
Kick Plate Spring	RS5-2501-000CN	8-7	14
Laser Cable (5L)	RG5-2035-000CN	8-6	13
Laser/Scanner (Exchange) (5L)	C3941-69003	8-3	19
Laser/Scanner (New) (5L)	RG5-2000-000CN	8-3	19
Laser/Scanner (New) (6L)	RG5-3494-000CN	8-3	19
Left Leg	RB1-7185-000CN	8-7	16

Table A-1

Alphabetical Parts List (continued)

Description	Part No.	Fig.	Ref.
Left Pressure Roller Housing	RB1-7255-000CN	8-5	13
Main Cover (5L)	RG5-1995-000CN	8-2	4
Main Cover (6L)	RG5-3443-000CN	8-2	4
Main Motor (5L)	RH7-1282-000CN	8-3	7
Main Motor (6L)	RH7-1320-000CN	8-3	7
Memory Door (5L)	RB1-7321-000CN	8-2	13
Memory Door (6L)	RB2-1639-000CN	8-2	13
Memory Door Guide	RB1-7109-000CN	8-4	1
Motor Cable	RG5-2033-000CN	8-6	11
Mylar Guide	RB1-7176-000CN	8-4	11
Nameplate (5L)	RB1-7335-000CN	8-2	8B
Nameplate (6L)	RB2-1641-000CN	8-2	8B
Output Extender 1 (5L)	RB1-7326-000CN	8-2	5
Output Extender 1 (6L)	RB2-1695-000CN	8-2	5
Output Extender 2 (5L)	RB1-7331-000CN	8-2	7
Output Extender 2 (6L)	RB2-1696-000CN	8-2	7
Output Tray Fin	RB1-7332-000CN	8-2	14
Paper Feed Frame	RB1-7177-000CN	8-7	1
Paper Kick Plate (5L)	RF5-1490-000CN	8-7	18
Paper Kick Plate (6L)	RF5-2372-000CN	8-7	18
Paper Pickup Roller Cable	RG5-2029-000CN	8-6	8
Pickup Roller Assembly (5L)	RG5-1951-000CN	8-7	4
Pickup Roller Assembly (6L)	RG5-3486-000CN	8-7	4
Pickup Roller Bushing	RB1-7184-000CN	8-7	5
Pickup Roller Grounding Clip	RB1-7223-000CN	8-5	1
Pressure Roller (5L)	RF5-1516-000CN	8-5	4
Pressure Roller (6L)	RF5-2362-000CN	8-5	4
Pressure Roller Bushing	RB1-7246-000CN	8-5	2
Pressure Roller Gear	RS5-0796-000CN	8-5	11
Pressure Roller Grease	CK-8006	8-5	
Pressure Roller Grounding Guide	RF5-1533-000CN	8-5	14
Right Leg	RB1-7186-000CN	8-7	17
Right Pressure Roller Housing	RB1-7256-000CN	8-5	12
Scanner Cable (5L)	RG5-2034-000CN	8-6	12
Scanner Cable (6L)	RG5-3661-000CN	8-6	12

Table A-1

Alphabetical Parts List (continued)

Description	Part No.	Fig.	Ref.
Screw	XA9-0724-000CN	8-2	11
Screw (with star washer)	XA9-0855-000CN	8-4	10
Screw	XB1-1300-807CN	8-4	502
Screw	XA9-0267-000CN	8-3	503
Screw	XA9-0824-000CN	8-5	17
Screw	XA9-0686-000CN	8-5	21
Screw	XA9-0724-000CN	8-4	9
Screw	XA9-0724-000CN	8-5	20
Screw	XB4-7401-0074CN	8-4	501
Screw	XB4-7401-0007	8-7	501
Screw	XB4-7401-007CN	8-2	501
Screw (5L)	XB6-7300-807CN	8-2	502
Screw (6L)	XA9-0267-000CN	8-2	502
Screw (DC Controller PCA) (5L)	XA9-0326-000CN	8-6	6
Screw (DC Controller PCA) (6L)	XA9-0890-000CN	8-6	6
Screw (DC Controller PCA)	XA9-0828-000CN	8-6	7
Screw	XB6-7300-607CN	8-3	501/502
Separation Guide Assembly (5L)	RG5-2013-000CN	8-9	
Separation Guide Assembly (6L)	RG5-3475-000CN	8-9	
Separation Pad Assembly	RY7-5008-000CN	8-7	2
Solenoid	RH7-5139-000CN	8-7	13
Spur Assembly Inside (5L)	RG5-2014-000CN	8-10	7
Spur Assembly Inside (6L)	RG5-3478-000CN	8-10	7
Spur Assembly Outside (5L)	RG5-2015-000CN	8-10	6
Spur Assembly Outside (6L)	RG5-3479-000CN	8-10	6
Thermistor Cable	RG5-2032-000CN	8-6	10
Transfer Guide Assembly (5L)	RG5-1961-000CN	8-5	23
Transfer Guide Assembly (6L)	RG5-3452-000CN	8-5	23
Transfer Roller	RF5-1534-000CN	8-5	7
Transfer Roller Guide (5L)	RF5-1530-000CN	8-5	6
Transfer Roller Guide (6L)	RF5-2358-000CN	8-5	6

Table A-2

Numerical Parts Index

Part No.	Description	Fig.	Ref.
C3941-69001	DC Controller PCA (110V) (Exchange) (5L)	8-6	3
C3941-69002	DC Controller PCA (220V) (Exchange) (5L)	8-6	3
C3941-69003	Laser Scanner (Exchange) (5L)	8-3	19
C3942-67902	Formatter (New) (5L)	8-6	2
C3942-69002	Formatter (Exchange) (5L)	8-6	2
C3991-60001	Formatter (New) (6L)	8-6	2
CK-8006	Pressure Roller Grease	8-5	
RB1-7105-000CN	Fuser Release Tab	8-3	3
RB1-7106-000CN	Gear Plate (5L)	8-3	4
RB1-7107-000CN	Front Gear Case	8-3	5
RB1-7109-000CN	Memory Door Guide	8-4	1
RB1-7129-000CN	Case Ground Metal	8-5	8
RB1-7130-000CN	Fuser Cable Guide	8-4	6
RB1-7176-000CN	Mylar Guide	8-4	11
RB1-7177-000CN	Paper Feed Frame	8-7	1
RB1-7184-000CN	Pickup Roller Bushing	8-7	5
RB1-7185-000CN	Left Leg	8-7	16
RB1-7186-000CN	Right Leg	8-7	17
RB1-7197-000CN	Clutch	8-7	6
RB1-7199-000CN	Back Ground Clip	8-7	7
RB1-7211-000CN	Input Extender 1 (5L)	8-2	1
RB1-7212-000CN	Input Extender 2 (5L)	8-2	2
RB1-7223-000CN	Pickup Roller Ground Clip	8-5	1
RB1-7226-000CN	Idler Roller (5L)	8-8	9
RB1-7234-000CN	Cap	8-4	7
RB1-7246-000CN	Pressure Roller Bushing	8-5	2
RB1-7247-000CN	Fuser Paper Guide	8-4	2
RB1-7255-000CN	Left Pressure Roller Housing	8-5	13
RB1-7256-000CN	Right Pressure Roller Housing	8-5	12
RB1-7276-000CN	Face-up/Face-down Shaft (5L)	8-9	2
RB1-7278-000CN	Face-up/Face-down Switch (5L)	8-2	4A
RB1-7284-000CN	Delivery Roller #1	8-10	1
RB1-7285-000CN	Delivery Roller #2 (5L)	8-10	2
RB1-7286-000CN	Delivery Spring #1	8-10	3
RB1-7287-000CN	Delivery Spring #2	8-10	4

Table A-2

Numerical Parts List (continued)

Part No.	Description	Fig.	Ref.
RB1-7288-000CN	Exit Roller Bushing	8-3	2
RB1-7289-000CN	Fuser Roller Bushing (5L)	8-9	4
RB1-7293-000CN	Flag	8-5	18
RB1-7294-000CN	Flag Spring	8-5	19
RB1-7302-000CN	Cap	8-4	8
RB1-7305-000CN	I/O Sheet Metal	8-4	12
RB1-7321-000CN	Memory Door (5L)	8-2	13
RB1-7326-000CN	Output Extender 1 (5L)	8-2	5
RB1-7327-000CN	EP Door Chimney (5L)	8-2	6
RB1-7331-000CN	Output Extender 2 (5L)	8-2	7
RB1-7332-000CN	Output Tray Fin	8-2	14
RB1-7333-000CN	Back Cover	8-2	3
RB1-7334-000CN	JP Protector	8-10	8
RB1-7335-000CN	Nameplate (5L)	8-2	8B
RB1-7341-000CN	EP Right Hand Guide #2	8-5	3
RB1-7343-000CN	Control Panel Cable Guide	8-4	5
RB1-7344-000CN	AC Cable Cover	8-4	3
RB1-7385-000CN	Ground Clip, Scanner	8-3	20
RB2-1632-000CN	Gear Plate (6L)	8-3	4
RB2-1636-000CN	Back Cover (6L)	8-2	3
RB2-1637-000CN	Input Extender 1 (6L)	8-2	1
RB2-1638-000CN	Input Extender 2 (6L)	8-2	2
RB2-1639-000CN	Memory Door (6L)	8-2	13
RB2-1641-000CN	Nameplate (6L)	8-2	8B
RB2-1644-000CN	Face-up/Face-down Switch (6L)	8-2	4A
RB2-1685-000CN	Delivery Roller #2 (6L)	8-10	2
RB2-1690-000CN	Fuser Roller Bushing (6L)	8-9	4
RB2-1695-000CN	Output Extender 1 (6L)	8-2	5
RB2-1696-000CN	Output Extender 2 (6L)	8-2	7
RB2-1697-000CN	EP Door Chimney (6L)	8-2	6
RB2-1699-000CN	Idler Roller (6L)	8-8	9
RB2-1719-000CN	Formatter Shield (6L)	8-6	1
RF5-1490-000CN	Paper Kick Plate (5L)	8-7	18
RF5-1501-030CN	EP Door Assembly (5L)	8-2	8
RF5-1509-000CN	Back Sheet Metal	8-4	4

Table A-2

Numerical Parts List (continued)

Part No.	Description	Fig.	Ref.
RF5-1514-000CN	EP Left Hand Guide	8-5	10
RF5-1515-000CN	EP Right Hand Guide #1	8-5	9
RF5-1516-000CN	Pressure Roller (5L)	8-5	4
RF5-1517-000CN	Fuser Pressure Plate	8-5	5
RF5-1521-000CN	Exit Roller (5L)	8-3	17
RF5-1522-000CN	Fuser Exit Roller Assembly (5L)	8-9	7
RF5-1530-000CN	Transfer Roller Guide (5L)	8-5	6
RF5-1533-000CN	PR Ground Guide	8-5	14
RF5-1534-000CN	Transfer Roller	8-5	7
RF5-2352-000CN	EP Door Assembly (6L)	8-2	8
RF5-2358-000CN	Transfer Roller Guide (6L)	8-5	6
RF5-2362-000CN	Pressure Roller (6L)	8-5	4
RF5-2367-000CN	Exit Roller (6L)	8-3	17
RF5-2368-000CN	Fuser Exit Roller Assembly (6L)	8-9	7
RF5-2372-000CN	Paper Kick Plate (6L)	8-7	18
RG5-1942-000CN	Feed Assembly (5L)	8-8	
RG5-1944-000CN	Input Assembly 1 (5L)	8-2	9
RG5-1945-000CN	Input Assembly 2 (5L)	8-2	10
RG5-1947-000CN	Idler Roller Shaft Assembly	8-7	9
RG5-1951-000CN	Pickup Roller Assembly (5L)	8-7	4
RG5-1961-000CN	Transfer Guide Assembly (5L)	8-5	23
RG5-1964-000CN	Heating Element (110 V) (5L)	8-5	16
RG5-1965-000CN	Heating Element (220 V) (5L)	8-5	16
RG5-1984-000CN	EP Cover Interlock (5L)	8-3	16
RG5-1995-000CN	Main Cover (5L)	8-2	4
RG5-2000-000CN	Laser Scanner, New (5L)	8-3	19
RG5-2012-000CN	Delivery Assembly (5L)	8-10	
RG5-2013-000CN	Separation Guide Assembly (5L)	8-9	
RG5-2014-000CN	Spur Assembly Inside (5L)	8-10	7
RG5-2015-000CN	Spur Assembly Outside (5L)	8-10	6
RG5-2023-000CN	DC Controller PCA (110 V) (5L)	8-6	3
RG5-2024-000CN	Formatter Shield (5L)	8-6	1
RG5-2025-000CN	DC Controller PCA (220 V) (5L)	8-6	3
RG5-2028-000CN	Control Panel PCA Assembly	8-5	22
RG5-2029-000CN	Paper Pickup Roller Cable	8-6	8

Table A-2

Numerical Parts List (continued)

Part No.	Description	Fig.	Ref.
RG5-2031-000CN	Door Sensor Cable (5L)	8-6	9
RG5-2032-000CN	Thermistor Cable	8-6	10
RG5-2033-000CN	Motor Cable	8-6	11
RG5-2034-000CN	Scanner Cable (5L)	8-6	12
RG5-2035-000CN	Laser Cable (5L)	8-6	13
RG5-2036-000CN	Control Panel PCA Cable (5L)	8-6	5
RG5-2037-000CN	Door Switch Cable (5L)	8-6	14
RG5-3443-000CN	Main Cover (6L)	8-2	4
RG5-3452-000CN	Transfer Guide Assembly (6L)	8-5	23
RG5-3453-000CN	EP/Cover Interlock (6L)	8-3	16
RG5-3459-000CN	Heating Element (110 V) (6L)	8-5	16
RG5-3463-000CN	Heating Element (220 V) (6L)	8-5	16
RG5-3474-000CN	Delivery Assembly (6L)	8-10	
RG5-3475-000CN	Separation Guide Assembly (6L)	8-9	
RG5-3476-000CN	Face-up/Face-down Shaft (6L)	8-9	2
RG5-3478-000CN	Spur Assembly Inside (6L)	8-10	7
RG5-3479-000CN	Spur Assembly Outside (6L)	8-10	6
RG5-3485-000CN	Feed Assembly (6L)	8-8	
RG5-3486-000CN	Pickup Roller Assembly (6L)	8-7	4
RG5-3488-000CN	Input Assembly 1 (6L)	8-2	9
RG5-3491-000CN	Input Assembly 2 (6L)	8-2	10
RG5-3494-000CN	Laser/Scanner (6L)	8-3	19
RG5-3499-000CN	Control Panel PCA Cable (6L)	8-6	5
RG5-3506-000CN	DC Controller PCA (110 V) (6L)	8-6	3
RG5-3509-000CN	DC Controller PCA (220 V) (6L)	8-6	3
RG5-3510-000CN	DC Controller PCA Case Assembly	8-6	4
RG5-3661-000CN	Scanner Cable (6L)	8-6	12
RG5-3662-000CN	Door Sensor Cable (6L)	8-6	9
RH3-8003-000CN	Fuse 102 (110 V)	8-6	
RH7-1282-000CN	Main Motor (5L)	8-3	7
RH7-1320-000CN	Main Motor (6L)	8-3	7
RH7-5139-000CN	Solenoid	8-7	13
RS5-0796-000CN	Pressure Roller Gear	8-5	11
RS5-2501-000CN	Kick Plate Spring	8-7	14
RY7-5005-000CN	Gear Kit #1	8-3	1

Table A-2

Numerical Parts List (continued)

Part No.	Description	Fig.	Ref.
RY7-5006-000CN	Gear Kit #2 (5L)	8-3	8
RY7-5007-000CN	Fuser Release Assembly	8-3	6
RY7-5008-000CN	Seperation Pad Kit	8-7	2
RY7-5009-000CN	Input Sensor Assembly	8-7	3
RY7-5036-000CN	Gear Kit #2 (6L)	8-3	8
VD7-0211-002CN	Fuse 101 (110 V)	8-6	
VD7-0643-151CN	Fuse 101 (220 V)	8-6	
VS1-5057-002CN	Fuser Connector	8-5	15
XA9-0267-000CN	Screw (6L)	8-2	502
XA9-0267-000CN	Screw	8-3	503
XA9-0326-000CN	Screw (DC Controller PCA) (5L)	8-6	6
XA9-0686-000CN	Screw	8-5	21
XA9-0724-000CN	Screw	8-2	11
XA9-0724-000CN	Screw	8-4	9
XA9-0724-000CN	Screw	8-5	20
XA9-0824-000CN	Screw	8-5	17
XA9-0828-000CN	Screw (DC Controller PCA)	8-6	7
XA9-0855-000CN	Screw (with star washer)	8-4	10
XA9-0890-000CN	Screw (DC Controller PCA) (6L)	8-6	6
XB1-1300-807CN	Screw	8-4	502
XB4-7401-007CN	Screw	8-2	501
XB4-7401-007CN	Screw	8-4	501
XB6-7300-607CN	Screw	8-3	501/502
XB6-7300-807CN	Screw (5L)	8-2	502

Regulatory Information

Laser Safety (U.S.A.)

The Center for Devices and Radiological Health (CDRH) of the U.S. Food and Drug Administration implemented regulations for laser products manufactured since August 1, 1976. Compliance is mandatory for products marketed in the United States.

This printer is certified as a “Class 1” laser product under the U.S. Department of Health and Human Services (DHHS) Radiation Performance Standard according to the Radiation Control for Health and Safety Act of 1968. Since radiation emitted inside this printer is completely confined within protective housings and external covers, the laser beam cannot escape during any phase of normal user operation.

WARNING!

Never operate or service the printer with the protective cover removed from the Laser/Scanner Assembly. The reflected beam, although invisible, can damage your eyes.

Laser Statement (Finland)

The following applies to printer operation and servicing in Finland.

LASERTURVALLISUUS

LUOKAN 1 LASERLAITE
KLASS 1 LASER APPARAT

HP LaserJet(s) 4V and 4MV laserkirjoitin on käyttäjän kannalta turvallinen luokan 1 laserlaite. Normaalisissa käyt"ssä kirjoittimen suojakotelointi estää lasersäteen pääsyn laitteen ulkopuolelle.

Kirjoittimen on hyväksynyt Suomessa laserturvallisuuden osalta Sähkö"tarkastuskeskus. Laitteen turvallisuusluokka on määritetty valtioneuvoston päät"ksen N:o 472/1985 ja standardin EN 60825 (1991) mukaisesti.

VAROITUS ! Laitteen käyttäminen muulla kuin käytt"ohjeessa mainitulla tavalla saattaa altistaa käyttäjän turvallisuusluokan 1 ylittävälle näkymätt"mälle lasersäteilylle.

VARNING ! Om apparaten används på annat sätt än i bruksanvisning specificerats, kan användaren utsättas för osynlig laserstrålning, som "verskrider gränsen för laserklass 1.

HUOLTO HP LaserJet(s) 4M and 4MV kirjoittimen sisällä ei ole käyttäjän huollettavissa olevia kohteita. Laitteen saa avata ja huoltaa ainoastaan sen huoltamiseen koulutettu henkilö". Tällaiseksi huoltotoimenpiteeksi ei katsota väriainekasetin vaihtamista, paperiradan puhdistusta tai muita käyttäjän käsikirjassa lueteltuja, käyttäjän tehtäväksi tarkoitettuja ylläpitotoimia, jotka voidaan suorittaa ilman erikoistyneitä kaluja.

VARO ! Mikäli kirjoittimen suojakotelo avataan, olet alttiina näkymätt"mälle lasersäteilylle laitteen ollessa toiminnassa. Älä katso säteeseen.

VARNING ! Om laserprinterns skyddsh"lje "ppnas då apparaten är i funktion, utsättas användaren för osynlig laserstrålning. Betrakta ej strålen.

Tiedot laitteessa käytettävän laserdiodin säteilyominaisuuksista:

Aallonpituus 777,795 nm
Teho 5 mW
Luokan 3B laser

Toner Safety

Note

In case of toner spills, skin and clothing are best cleaned by removing as much toner as possible with a dry tissue, then washing with cold water. Hot water causes toner to permanently set into clothing.

MSDS Information

A Material Safety Data Sheet (MSDS) for toner or any other chemical used in the printer is available through Hewlett-Packard's Customer Information Center by either mail or fax.

By mail:

To obtain an MSDS for the HP C3906A toner cartridges through the mail, call the Customer Information Center (CIC) at 1-800-752-0900 between 6 A.M. and 5 P.M. Pacific Standard Time.

By fax:

To obtain an MSDS for the HP C3906A toner cartridges by fax, call HP ASAP (Automated Support Access Program) at 1-800-333-1917 and follow the instructions for using the HP FIRST fax service.

Note

See "Technical Assistance" in chapter one for more information on the HP FIRST service.

Ozone Emission

These printers do not use high voltage corona wires in the electrophotographic process, and therefore generate no measurable ozone gas (O₃). The printers instead use charging rollers in the toner cartridge and in the print engine.

FCC Statement (Class B)

Note: This equipment has been tested and found to comply with the limits for a Class B digital device, pursuant to part 15 of the FCC rules. These limits are designed to provide reasonable protection against harmful interference in a residential installation. This equipment generates, uses, and can radiate radio frequency energy and, if not installed and used in accordance with the instructions, may cause harmful interference to radio communications. However, there is no guarantee that interference will not occur in a particular installation. If this equipment does cause harmful interference to radio or television reception, which can be determined by turning the equipment off and on, the user is encouraged to try to correct the interference by one or more of the following measures:

- Reorient or relocate the receiving antenna.
- Increase the separation between the equipment and the receiver.
- Connect the equipment into an outlet on a circuit different from that to which the receiver is connected.
- Consult the dealer or an experienced radio/TV technician for help. Any changes or modifications not expressly approved by Hewlett-Packard could void the user's authority to operate this equipment.

Note

Use of a shielded interface cable is required to comply within the Class B limits in Part 15 of FCC rules.

VCCI Statement (Japan)

The VCCI statement below is required in Japan. It is similar to the FCC regulatory statement.

Figure B-1

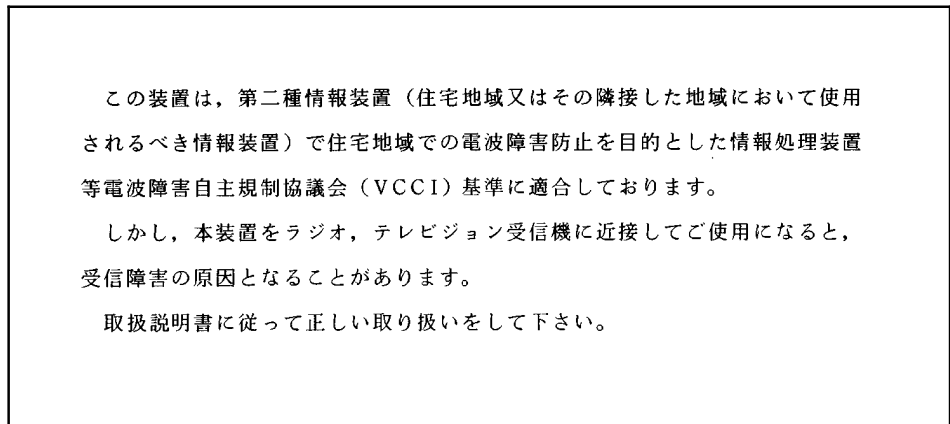

VCCI Statement (Japan)

Service Notes

Fuser Accordion Jams

C3941A-01

SERVICE NOTE

SUPERSEDES: NONE

HP C3941A LaserJet 5L

Serial Numbers: <JPBB022333
 <JPTB000101
 <JPBJ041310
 <JPBK006151
 <JPBL033831
 <JPTJ000101
 <JPTK000101
 <JPTL000101
 <USBB158323
 <JPTM080500
 <JPBM007279
 <JPBT000101
 <JPBV000101
 <JPTT090666
 <JPTV122612
 <JPTX029034

LaserJet 5L Printer Fuser Accordion Jams

To Be Performed By: HP-Authorized personnel or Customer

Parts required: RB1-7332-000CN output tray fin

General Description:

Under some conditions the paper can be pushed back down into the fuser. This results in a paper jam in the fuser area. The paper jam can be so severe that the customers cannot remove the paper and the printer requires servicing.

DATE 20 February 1996

ADMINISTRATIVE INFORMATION

SERVICE NOTE CLASSIFICATION:			
MODIFICATION RECOMMENDED			
ACTION CATEGORY:	<input type="checkbox"/> IMMEDIATELY <input checked="" type="checkbox"/> ON SPECIFIED FAILURE <input checked="" type="checkbox"/> AGREEABLE TIME	STANDARDS: LABOR: 0.5 Hours	
LOCATION CATEGORY:	<input checked="" type="checkbox"/> CUSTOMER INSTALLABLE <input type="checkbox"/> ON-SITE <input checked="" type="checkbox"/> HP LOCATION	SERVICE INVENTORY: <input type="checkbox"/> RETURN <input type="checkbox"/> SCRAP <input type="checkbox"/> SEE TEXT	USED PARTS: <input type="checkbox"/> RETURN <input type="checkbox"/> SCRAP <input type="checkbox"/> SEE TEXT
AVAILABILITY:	PRODUCT'S SUPPORT LIFE	RESPONSIBLE UNTIL: February 1998	
AUTHOR: SKL	ENTITY: 4600	ADDITIONAL INFORMATION:	

To remove the paper jam the fuser area of the printer must be disassembled. Fusers and pressure rollers should be checked for damage from the paper jam or the customers attempts to remove the paper jam.

The output tray fin should be installed in all LaserJet 5L's in the affected serial number range that are returned for any service, paper jam or other.

Solution:

The out try fin (RB1-7332-000CN) should be placed in the output tray of the printer. This will decrease the number of fuser paper jams customers are experiencing. The fin should be installed in all printers that do not already have it. See graphic for placement of the part.

ADMINISTRATIVE INFORMATION _____

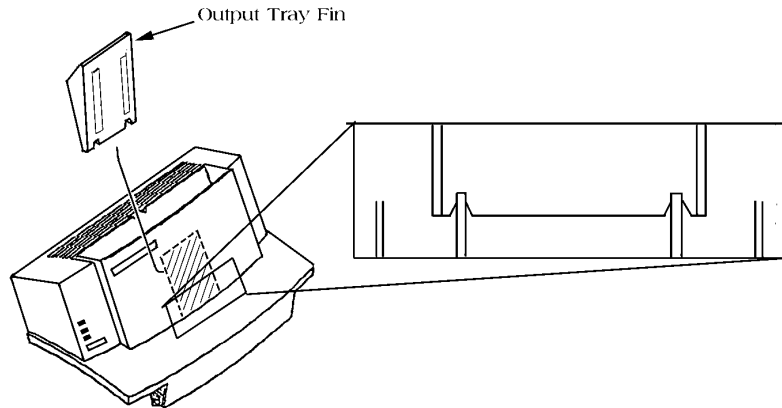

Fuser Jam Clearing Countermeasure

C3941A-02A

SERVICE NOTE

SUPERSEDES: C3941A-02

HP C3941A LaserJet 5L

Serial Numbers:

JPBK000000 / JPBK016388
JPBL000000 / JPBL055374
JPCW000000 / JPCW043448
JPVW000000 / JPVW081157
USCB000000 / USCB302011
JPBV000000 / JPBV010501
JPVV000000 / JPVV216255
CNVM000000 / CNVM175233
CNVN000000 / CNVN189964

LaserJet 5L Printer Fuser Jam Clearing Countermeasure

To Be Performed By: HP-Authorized Personnel

Parts required: RB1-7334-000CN JP (Jam Prevention) Protector

General Description:

When a paper jam occurs in the LaserJet 5L it will commonly occur in the fuser area, with the paper folding accordion-style between the fuser and delivery assembly. The paper jams in the fuser can be such that the customers cannot remove the paper and the printer requires servicing. Customers attempting to clear the jams often cause damage to the printer. This countermeasure will not prevent paper jams, but will allow users to clear the paper jams without damaging the printer.

Continued

DATE 10 June 1996

ADMINISTRATIVE INFORMATION

SERVICE NOTE CLASSIFICATION:			
MODIFICATION RECOMMENDED			
ACTION CATEGORY:	<input type="checkbox"/> IMMEDIATELY <input checked="" type="checkbox"/> ON SPECIFIED FAILURE <input type="checkbox"/> AGREEABLE TIME	STANDARDS: LABOR: 0.5 Hours	
LOCATION CATEGORY:	<input type="checkbox"/> CUSTOMER INSTALLABLE <input type="checkbox"/> ON-SITE <input checked="" type="checkbox"/> HP LOCATION	SERVICE INVENTORY: <input type="checkbox"/> RETURN <input type="checkbox"/> SCRAP <input type="checkbox"/> SEE TEXT	USED PARTS: <input type="checkbox"/> RETURN <input type="checkbox"/> SCRAP <input type="checkbox"/> SEE TEXT
AVAILABILITY:	PRODUCT'S SUPPORT LIFE	RESPONSIBLE UNTIL: 10 May 1998	
AUTHOR: SKL	ENTITY: 4600	ADDITIONAL INFORMATION: Reissued to correct Figure A.	

To remove this type of paper jam the fuser area of the printer must be disassembled. The fuser and pressure roller should be checked for damage from the paper jam or the customer's attempts to remove the paper jam. See chapter 6 in the service manual for disassembly instructions.

This JP protector and the output tray fin (from service note C3941A-01) should be installed in all LaserJet 5L's in the affected serial number range that are being serviced.

Solution:

This JP Protector (RB1-7334-000CN) should be added to the delivery assembly (RG5-2012-000CN) of every printer in the affected serial number range that is serviced. To install this part you must remove the delivery assembly, per the service manual (page 6-13/14). The JP Protector is shown in Figure A below. The Delivery Assembly is shown in Figure 8-10 of the Service manual. Install the JP Protector into the Delivery Assembly in the position shown in Figure B below. Figure B shows a right side view of the Delivery Assembly with the JP Protector installed. Be very careful to orient the part correctly.

JP Protector

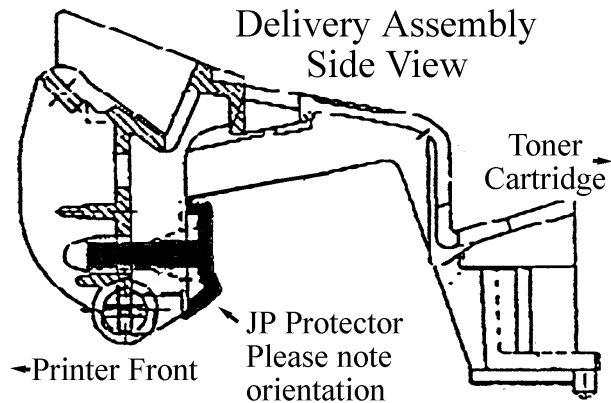
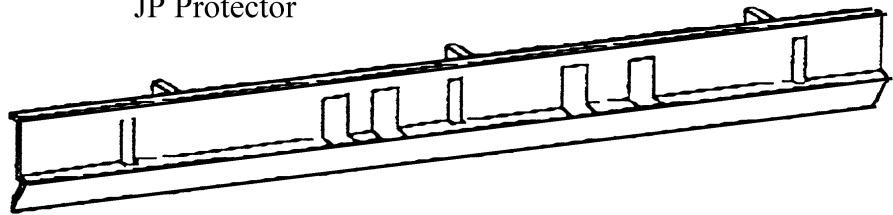

Index

A

AC power distribution 5-6
 circuitry 5-6
accessories and supplies 8-5
acoustic emissions 1-6
assistance, technical 1-12

B

background scatter 7-16
black page 7-16
blank page
 all pages 7-18
 occasional 7-18
bottom assemblies
 DC Controller 6-44
 formatter PCA 6-47
 memory door guide 6-42
 motor 6-43

C

cable pinouts 7-30
cables
 replaceable 8-6
capacities: output tray 1-3
caution messages 6-3
CDRH B-1
Center for Devices and Radiological
 Health (CDRH) B-1
character voids 7-16
circuit protection 5-6
class 1 laser product B-1
class B digital device B-4
cleaning
 printer 4-6
 spilled toner 4-8
clutches and sensors 5-17
common hardware 8-6
consumables
 ordering 8-4
 printer 1-10
control panel 1-3
 described 5-9
 features 1-3, 3-3
 layout 3-3
 messages 7-8
 self test for printer errors 7-8
 settings 5-9
 using 3-3
covers 8-7
covers and doors 8-8
 back cover 6-6
 EP Door 6-8
 main cover and paper input assembly
 6-10
 memory door 6-9
CPU 5-8
CPU, printer 5-8

D

data light 3-3
DC Controller 8-16
 diagram 7-6
DC Controller system 5-5
DC power distribution
 circuitry 5-6
 explained 5-6
defect ruler, repetitive image 7-28
delivery assembly 8-24
Department of Health and Human
 Services (DHHS) B-1
DHHS B-1
diagrams 8-3
dimensions, printer 1-3, 1-6, 2-4
distribution system
 AC 5-6
documentation
 related 1-10 to 1-11
doors 8-7
DRAM
 installation 6-5
dropouts 7-17
drum
 photosensitive 5-13, 7-13, 7-22 to
 7-23
drum cleaning process
 described 5-12 to 5-13
drum conditioning
 described 5-12 to 5-13
drum rotation functional check 7-23

E

EconoMode 1-3, 5-10
 print speed 5-10
 vs. normal mode 5-10
electrical specifications 1-6
emissions
 acoustic 1-6
engine test 3-10, 7-21
 printing 7-21
engine test button location 7-21
engine test microswitch, SW201 5-5
environment
 operating 2-3
environmental requirements 2-5
error light 3-3
 unclearable 7-9
exchange program 1-10

F

faded print 7-14
faulty image examples 7-14
FCC statement B-4
features
 control panel 1-3, 3-3
feed assembly 8-20
Finland laser statement B-2

fonts

 downloaded 5-6
 internal 1-3
 internal character sets 5-8
 storing 5-8
fonts, internal 1-3
form feed light 3-4 to 3-5
formatter PCA 8-16
 Motorola 68030 microprocessor 5-8
 Bi-tronics interface 5-8
 DC controller PCA 5-19
 described 5-8
 engine test print 3-10
 HVPS PCA 5-7
 REt 5-9
 self test bypass 5-5
 voltages 5-6
formatter PCA 5-8
formatter system
 described 5-8
front door components 8-10, 8-12
Front Panel Button, described 5-7
functional overview 5-1 to 5-22
functions, basic printer 5-3
fusing process 5-14

H

half page blank 7-17
half self test check
 purpose 7-22
half self test functional check 7-22
hardware, common 8-6
high voltage power distribution 5-7
high voltage power supply PCA 5-7
high-voltage power supply check 7-24
horizontal stripes 7-15
HPD, HP's Distribution Center 1-11

I

identification, labels 1-4
identification, printer 1-4
image defects 7-28
image developing 5-12, 5-14
image formation system
 block diagram 5-12
 DC controller 5-8
 described 5-12
 features 5-12
 toner cartridge 5-13, 7-13
image formation troubleshooting 7-13
image fusing 5-12, 5-14
image transferring 5-12, 5-14
image writing 5-12 to 5-13
installation
 DRAM 6-5
installing
 memory cards 6-5
interfaces

- standard 1-3
- internal assemblies 8-10, 8-12, 8-14
 - control panel 6-11
 - delivery assembly 6-13
 - exit roller assembly 6-12
 - face-up/face-down lever 6-21
 - fuser exit roller 6-22
 - fuser pressure plate 6-15
 - heating element 6-17
 - pressure roller 6-20
- internal typefaces 1-3
- INTR, printer timing 5-19
- J**
- Japanese VCCI Statement B-4
- L**
- laser and scanner drive 5-5
- laser drive 5-5
- laser safety information B-1
- Laser Safety, USA B-1
- laser statement, Finland B-2
- loss of detail 7-17
- LSTR, printer timing 5-19
- M**
- main wiring diagram 7-29
- maintenance 4-1 to 4-8
- Material Safety Data Sheet, MSDS B-3
- memory
 - buffer 5-11
 - MEt 1-3, 5-10
 - printer 1-3, 5-8, 5-10
 - RAM 5-8
 - ROM 5-8
 - upgrades 8-5
- memory cards (DRAM)
 - installation 6-5
- memory enhancement technology 5-10
 - described 5-10
- MEt 5-10
- microswitch
 - SW101 5-5
 - SW201 5-5
- model number 1-4
- model, printer 8-3
- motor
 - described 5-5
- MSDS B-3
- N**
- North American Response 1-13
- O**
- operating environment 2-3
- operation, basic sequence 5-19
- ordering
 - related 1-10
- ordering consumables 8-4
- ordering parts 1-10, 8-3
- output components 8-14
- overcurrent
 - dc protection circuitry 5-6
 - devices 5-6
 - protection 5-6
- overvoltage
 - devices 5-6
 - protection 5-6
- ozone emission B-3
- P**
- page protect
 - described 5-11
 - disabled 5-11
 - page buffer 5-11
 - PCL printing 5-11
- page usage, monthly 1-3
- paper capacities 1-3
- paper curl 7-26
- paper feed system
 - clutches and sensors 5-17
 - described 5-15
 - paper path 5-16, 7-5
- paper jam
 - DC controller 5-18
 - messages 7-7
 - toner 4-8
- paper jam detection
 - described 5-18
- paper motion, control 5-5
- paper motion, monitoring 5-5
- paper path
 - components 7-5
 - location 5-16
 - troubleshooting 7-27
- paper sensors 5-5
- parallel interface
 - described 5-8
- parts
 - HPD 1-11
 - ordering 1-10, 8-3
 - Parts Direct Ordering 8-3
 - PDO, Parts Direct Ordering 1-11, 8-3
 - phone numbers 8-4
 - SME, Support Materials Europe 1-11
 - Parts 1-10
- parts and diagrams 8-1 to 8-26
- Parts Direct Ordering 8-3
- parts lists 8-3
- PDO, Parts Direct Ordering 1-11, 8-3
- phone numbers, parts 8-4
- photosensitive drum 5-13
 - check list 7-22
 - damage 7-13
 - described 5-13
 - located 7-23
- photosensitive drum cleaning 5-12 to 5-13
- photosensitive drum conditioning 5-12 to 5-13
- pickup roller assembly 8-18
- PJL overview 5-11
- PJL, Printer Display Language
 - Centronics cabling 5-11
 - described 5-11
 - print environment settings 5-11
 - two-way communication 5-11
- power
 - surge 1-15
- power control 1-3
- power distribution, AC 5-6
- power save mode 1-3, 5-6
- power supply system 5-4
- preliminary troubleshooting 7-3
- print environment settings, PJL 5-11
- print quality
 - cleaning printer 4-6
 - transfer roller 4-7
- print quality problems 7-14
 - all blank pages 7-18
 - background scatter 7-16
 - black page 7-16
 - blank page 7-18
 - character voids 7-16
 - dropouts 7-17
 - faded print 7-14
 - half blank page 7-17
 - horizontal stripes 7-15
 - loss of detail 7-17
 - repetitive defects 7-15
 - staining 7-14
 - vertical lines 7-15
 - vertical white stripes 7-15
- print resolution 1-3
- print speed 1-3, 5-8, 5-10
- printer
 - buffer memory 5-11
 - cleaning 4-6
 - fonts 1-3
 - memory 1-3, 5-8, 5-10
 - memory upgrade 8-5
 - MEt 5-10
 - model number 1-4
 - optional memory 1-3
 - reset 3-11
 - standard memory 1-3
 - warranty 1-14
 - warranty 1-15
 - warranty exclusions 1-14
- printer comparison
 - memory 1-3
- printer dimensions 1-3, 1-6, 2-4
- printer features 1-3
 - internal typefaces 1-3
 - memory 1-3
 - monthly usage 1-3
 - speed 1-3
- printer functions, basic 5-3
- printer job language, PJL 5-11
- printer message troubleshooting 7-7
- printer messages
 - control panel 7-8
 - error 7-8
 - manual feed 7-7
 - memory error 7-7
 - paper out 7-7
 - Ready 7-8
 - self test 7-8
 - status 7-8
 - toner cartridge 7-7
 - troubleshooting 7-7
- printer space requirements 2-4
- printer timing 5-19
 - INTR 5-19
 - LSTR 5-19

- PRNT 5-19
- STBY 5-19
- WAIT 5-19
- printing
 - self test page 3-7
- priority of errors 7-7
- PRNT, printer timing 5-19
- product information 1-1 to 1-16, 3-1 to 3-12
- product overview 1-7
- R**
- radio frequency interference, RFI B-4
- RAM 5-8
 - described 5-8
- random access memory
 - described 5-8
- read only memory
 - described 5-8
- ready light 3-3
- regulatory information B-1 to B-4
- related documentation 1-10 to 1-11
- remanufactured assemblies 1-10
- removal and replacement
 - back cover 6-6
 - bottom assemblies 6-42
 - conductive grease 6-20
 - control panel 6-11
 - covers and doors 6-6
 - DC Controller 6-44
 - delivery assembly 6-13
 - EP Door 6-8
 - exit roller assembly 6-12
 - face-up/face-down lever 6-21
 - feed assembly 6-39
 - formatter pca 6-47
 - fuser exit roller 6-22
 - fuser pressure plate 6-15
 - heating element 6-17
 - internal assemblies 6-11
 - kick plate 6-35
 - laser/scanner assembly 6-24
 - main cover and paper input assembly 6-10
 - memory door 6-9
 - memory door guide 6-42
 - motor 6-43
 - paper exit sensor flag 6-23
 - paper feed frame 6-30
 - pickup roller assembly 6-27
 - pressure roller 6-20
 - separation pad 6-37
 - solenoid 6-25
 - strategy 6-3
 - subpads 6-38
 - top assemblies 6-24
 - transfer roller 6-34
- repair philosophy 1-10
- repetitive defects 7-15
- repetitive image defect ruler 7-28
- replaceable cables 8-6
- required tools 6-4
- requirements
 - environmental 2-5

- site 2-1 to 2-6
- space 2-4
- resetting the printer 3-11
- Resolution Enhancement technology
 - 1-3, 5-9
 - described 5-9
- resolution, print 1-3
- REt, Resolution Enhancement technology 1-3, 5-9
- ROM 5-8
 - character sets 5-8
 - dot patterns 5-8
- S**
- safety
 - toner B-3
- scanner drive 5-5
- self test
 - engine 3-10
 - microswitch SW201 5-5
- self test page 3-7
- sensors 5-17
- separation guide assembly 8-22
- sequence of operation 5-19
- serial number
 - information 1-4
- service approach 1-10
- service errors 7-7
- service or error messages
 - beam error 7-11
 - engine 7-11
 - firmware 7-12
 - formatter 7-12
 - fuser 7-10
 - ROM or RAM 7-10
 - scanner 7-12
- site requirements 2-1 to 2-6
- SME, Support Materials Europe 1-11
- solving
 - print quality problems 7-14
- space requirements 2-4
- specifications
 - electrical 1-6
 - paper 1-11
 - printer 1-6, 2-3
- staining 7-14
- standard interfaces 1-3
- standard printer memory 1-3
- status messages
 - door open or no EP cartridge 7-8
 - incompatible memory card 7-8
 - manual feed 7-8
 - memory error 7-8
 - paper jam 7-8
 - paper out 7-8
 - Ready 7-8
 - SleepMode 7-9
- STBY, printer timing 5-19
- supplies 8-5
 - See also accessories and supplies
- surge protection 1-15
- SW101, 12 volt dc power shutoff
 - microswitch 5-5
- SW101, printer door microswitch 5-5

- SW201, engine test microswitch 5-5
- T**
- technical assistance 1-12
- test, engine 3-10
- toner 1-10
- toner cartridge
 - charging rollers B-3
 - check list 7-13
 - cleaning spills 4-8
 - defective 4-8
 - described 5-13
 - drum cleaning 5-12 to 5-13
 - drum conditioning 5-12 to 5-13
 - drum rotation check 7-23
 - faulty image examples 7-14
 - image formation 7-13
 - image formation system 5-13
 - MSDS B-3
 - photosensitive drum 5-13, 7-13, 7-22 to 7-23
 - printer message 7-7
 - refilled 7-23
 - replacement 8-5
 - weight 7-13
- toner cartridge microswitch, SW101 5-5
- toner safety B-3
- tools
 - required 6-4
- top assemblies
 - feed assembly 6-39
 - kick plate 6-35
 - laser/scanner assembly 6-24
 - paper feed frame 6-30
 - pickup roller assembly 6-27
 - separation pad 6-37
 - solenoid 6-25
 - transfer roller 6-34
- transferring process 5-14
- troubleshooting 7-1 to 7-32
 - drum rotation 7-23
 - high-voltage power supply check 7-24
 - image defects 7-28
 - image formation 7-13
 - LEDs 7-7
 - paper curl 7-26
 - paper path 7-27
 - print quality problems 7-14
 - printer errors 7-7
- troubleshooting checks 7-21
- troubleshooting flowchart 7-3
- troubleshooting tools 7-27
- troubleshooting, preliminary 7-3
- two-way communication, PjL 5-11
- typefaces
 - internal 1-3
- V**
- VCCI Statement, Japan B-4
- vertical lines 7-15
- vertical white stripes 7-15
- voltage conversions 1-15
- W**
- WAIT, printer timing 5-19

- warning messages 6-3
- warranty
 - exclusions 1-14
 - limitations 1-15
 - start date 1-15
 - voltage 1-15
- warranty 1-14
- wiring diagram 7-29
- wiring diagrams, main 7-29
- writing process 5-13

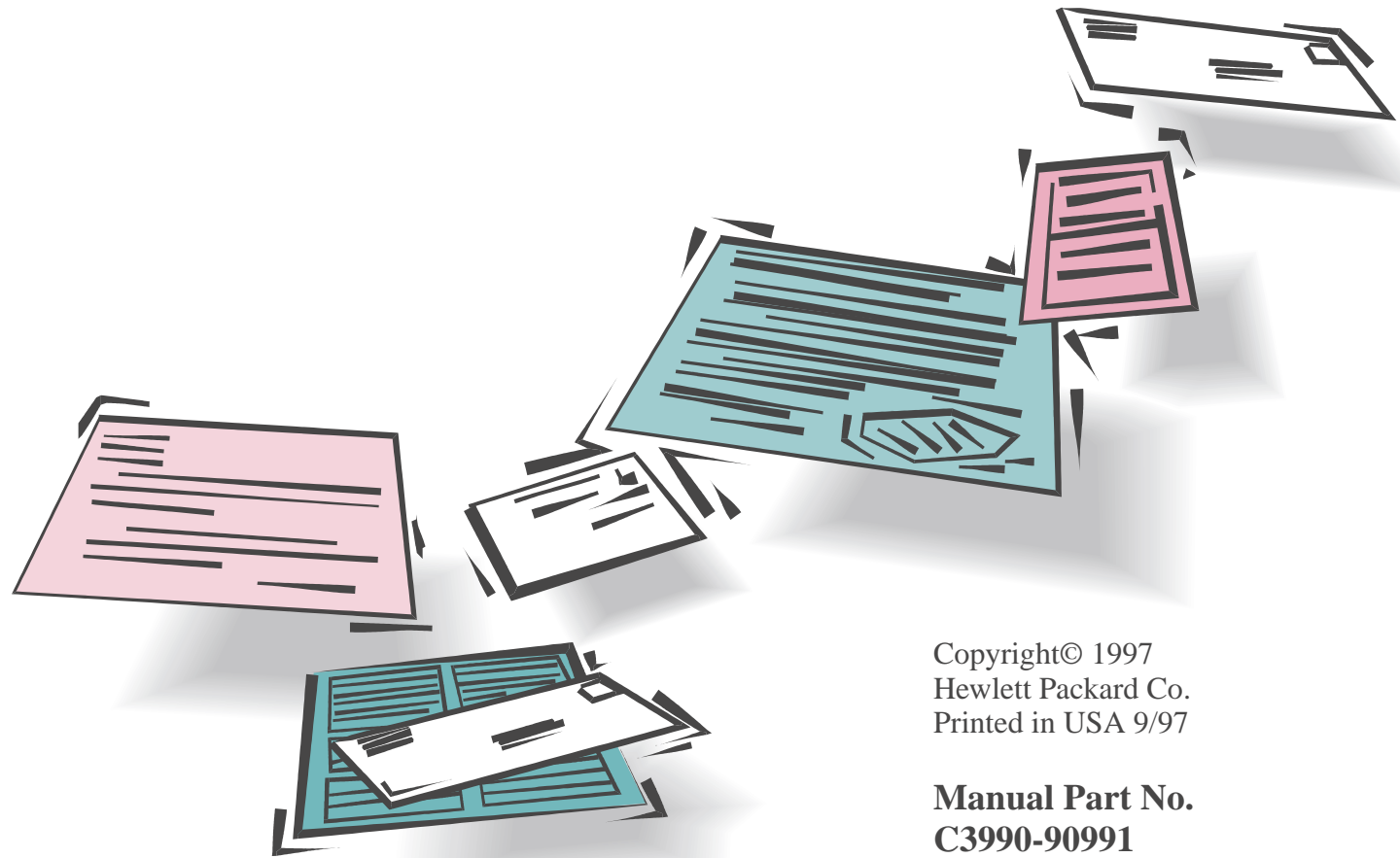

Copyright© 1997
Hewlett Packard Co.
Printed in USA 9/97

**Manual Part No.
C3990-90991**



C3990-90991



Printed on
Recycled Paper

www.s-manuals.com