

Human NIBP

Non-invasive hemodynamics

Owner's Guide



This document was, as far as possible, accurate at the time of release. However, changes may have been made to the software and hardware it describes since then. ADInstruments Pty Ltd reserves the right to alter specifications as required. Late-breaking information may be supplied separately.

Trademarks of ADInstruments

PowerLab®, LabChart®, LabTutor®, LabAuthor® and MacLab® are registered trademarks of ADInstruments Pty Ltd. The names of specific recording units, such as PowerLab 8/35, are trademarks of ADInstruments Pty Ltd. LabTutor Server, Chart and Scope (application programs) and LabTutor Online are trademarks of ADInstruments Pty Ltd.

Other Trademarks

Apple, Mac and Macintosh are registered trademarks of Apple Computer, Inc. Windows, Windows 7 and Windows Vista are either registered trademarks or trademarks of Microsoft Corporation.

All other trademarks are the property of their respective owners.

Product: Human NIBP Controller
Part Number for this document: 6113-B

Copyright © 2014 ADInstruments Pty Ltd.
Unit 13, 22 Lexington Drive, Bella Vista, NSW 2153, Australia

All rights reserved. No part of this document may be reproduced by any means without the prior written permission of ADInstruments Pty Ltd.

Web: www.adinstruments.com
Technical Support: support.au@adinstruments.com
Documentation: documentation@adinstruments.com

Contents

Contents	i
Safety Notes	1
1 Overview	7
The Human NIBP Controller	8
The Front Panel	8
The Back Panel	9
Symbols	11
2 Using the Controller	13
Install ADInstruments Software	14
Check the installation	15
The S (HCU)	17
Using Finger Cuffs	19
Warnings on cuff handling	19
Starting up the software	24
Human NIBP Settings	26
Auto calibration enabled	26
Finger cuff switching	27
Performing the Height Correction Procedure	29
Starting a measurement	30
Stopping a measurement	31
Use of comments	32
Test mode	32
Troubleshooting	36
A Technical Details	43
How it Works	43
Photoplethysmography	44
Plethysmograph	45
The pressure-diameter relationship	47
Volume-clamp method	48

PhysioCal algorithm	49
Measurement accuracy	55
Comparison with intra-arterial blood pressure	55
Clinical use	58

B References 63

Finger arterial pressure methods	63
Clinical Experience	65

C Specifications 69

D Warranty 77

Product Purchase and License Agreement	77
Software License Agreement	82



Safety Notes

Statement of Intended Use

All products supplied by ADInstruments are intended for use in teaching and research applications and environments only. ADInstruments products are NOT intended to be used as medical devices or in medical environments. That is, no product supplied by ADInstruments is intended to be used to diagnose, treat or monitor a subject. Furthermore, no product is intended for the prevention, curing or alleviation of disease, injury or handicap.

Where a product meets IEC60601-1 it is under the principle that:

- it is a more rigorous standard than other standards that could be chosen.
- it provides a high safety level for subjects and operators.

The choice to meet IEC60601-1 is in no way to be interpreted to mean that a product:

- is a medical device.
- may be interpreted as a medical device.
- is safe to be used as a medical device.

Safety Symbols

Devices distributed and manufactured by ADInstruments that are designed for direct connection to humans are tested to standards IEC60601-1:1998 (including amendments 1 and 2) and IEC60601-1-2, and carry one or more of the safety symbols below. These symbols appear next to those inputs and output connectors (or ‘applied parts’) of the medical device that can be directly connected to human subjects.



B symbol



BF symbol

These symbols are:

- **B symbol.** This classification is a less stringent certification than the BF symbol; it certifies that an instrument is safe for direct human connection. It applies to the Human NIBP Controller. The B symbol appears on the applied parts that, in general, are not conductive and can be immediately released from the subject. Type B applied parts may be connected to earth, while Type BF is ‘floating’ and must be separated from earth.
- **BF (body protected) symbol.** This symbol appears next to those inputs and output connectors that can be directly connected to human subjects. This means that the input connectors are suitable for connection to humans provided there is no direct electrical connection to the heart.

Further information is available on request.

Avoiding Injury to Subjects and Personnel

- Selecting a properly-sized finger cuff and correct placement of the cuff on a finger are critical for success. Finger cuffs should not be applied to any body part other than the fingers.
- Accuracy of measurement on a toe has not been established.
- An inflated finger cuff applied to the wrist causes congestion of blood in the distal circulation of the hand, which may become painful and restricts distal oxygenation.
- Do not wrap finger cuffs around a toe or the wrist of an infant.
- For safe and reliable operation and optimal accuracy, only use finger cuffs supplied by ADInstruments and Finapres Medical Systems B.V.
- Externally generated analog signals coming from other devices, such as respiratory signals and ECGs, can be connected to the ADInstruments PowerLab system for recording. Connected equipment has to meet the IEC specifications (IEC601 for electro medical devices or IEC950 for data processing devices). The configuration has to meet the IEC system standard (IEC60601-1-1). He who connects such additional devices is responsible for adherence to the IEC60601-1-1 standard.

General Safety Instructions

To achieve the optimal degree of subject and operator safety, consideration should be given to the following guidelines when setting up a Human NIBP system either as stand-alone equipment or in conjunction with other equipment. Failure to do so may compromise the inherent safety measures designed into Human NIBP equipment.

The following guidelines are based on principles outlined in the international safety standard IEC60601-1-1: *General requirements for safety - Collateral standard: Safety requirements for medical systems*. Reference to this standard is required when setting up a system for human connection.

The Human NIBP system requires the connection of a personal computer for operation. This personal computer should be certified as complying with IEC60950 and should be located outside a 1.8 m radius from the subject (so that the subject cannot touch it while connected to the system). Within this 1.8 m radius, only equipment complying with IEC60601-1 should be present.

Connecting a system in this way obviates the provision of additional safety measures and the measurement of leakage currents.

Accompanying documents for each piece of equipment in the system should be thoroughly examined prior to connection of the system.

While it is not possible to cover all arrangements of equipment in a system, some general guidelines for safe use of the equipment are presented below:

- Any electrical equipment which is located within the SUBJECT AREA should be approved to IEC60601-1.
- Only connect those parts of equipment that are marked as an APPLIED PART to the subject. APPLIED PARTS may be recognized by the B or BF symbols (see Safety Symbols section).
- Never connect parts which are marked as an APPLIED PART to those which are not marked as APPLIED PARTS.
- Do not touch the subject to which the Human NIBP system is connected at the same time as making contact with parts of the Human NIBP system (or its peripherals) that are not intended for contact to the subject.
- Cleaning and sterilization of equipment should be performed in accordance with manufacturer's instructions. The isolation barrier may be compromised if manufacturer's cleaning instructions are not followed.
- The ambient environment (such as the temperature and relative humidity) of the system should be kept within the manufacturer's specified range or the isolation barrier may be compromised. An explosion hazard exists when operated in the presence of flammable gases and liquids.
- The entry of liquids into equipment may also compromise the isolation barrier. If spillage occurs, the manufacturer of the affected equipment should be contacted before using the equipment.
- Many electrical systems (particularly those in metal enclosures) depend upon the presence of a protective earth for electrical safety. This is generally provided from the power outlet through a power cord, but may also be supplied as a dedicated safety earth conductor. Power cords should never be modified so as to remove the earth connection. The integrity of the protective earth connection between each piece of equipment and the protective earth should be verified regularly by qualified personnel.
- Avoid using multiple portable socket-outlets (such as power boards) where possible as they provide an inherently less safe environment

with respect to electrical hazards. Individual connection of each piece of equipment to fixed mains socket-outlets is the preferred means of connection.

If multiple portable socket outlets are used, they are subject to the following constraints:

- They shall not be placed on the floor.
- Additional multiple portable socket outlets or extension cords shall not be connected to the system.
- They shall only be used for supplying power to equipment which is intended to form part of the system.

Cleaning and Sterilization

ADInstruments products may be wiped down with a lint free cloth moistened with industrial methylated spirit. Refer to the Data Card supplied with transducers and accessories for specific cleaning and sterilizing instructions.

Preventative Inspection and Maintenance

The Human NIBP components are maintenance-free and do not require periodic inspection to ensure safe operation. There is no need to open any of the device's components for inspection or maintenance, and doing so within the warranty period will void the warranty.

The zero adjustment of all built-in pressure transducers is automatic, except for the pressure transducer in the S for which zeroing has to be performed manually (see on page 28). It is the responsibility of the operator to periodically check the zeros and sensitivities of the transducers.

Human NIBP components leave our premises with carefully calibrated transducers. Immediately after transport, or at any time that the instrument is dropped or otherwise damaged, the zeros and calibrations should be rechecked. These checks are quick and easy to perform (see Pressure check on page 39). Follow these instructions for testing the device if performing such tests.

If the Human NIBP system is found not to comply with such testing you should contact your ADInstruments representative to arrange for the

equipment to be checked and serviced. Do not attempt to service the device yourself.

Environment

Electronic components are susceptible to corrosive substances and atmospheres, and must be kept away from laboratory chemicals. The Human NIBP Controller has a narrow temperature operating range (see Operating Conditions below) and should be placed apart from other equipment for optimal operation.

Storage Conditions

- Temperature in the range -20–70 °C
- Non-condensing humidity in the range 5–90%.

Operating Conditions

- Temperature in the range 10–40 °C
- Non-condensing humidity in the range 5–90%.

Disposal

- Forward to recycling center or return to manufacturer.
- Unwanted equipment bearing the Waste Electrical and Electronic Equipment (WEEE) Directive symbol requires separate waste collection. For a product labeled with this symbol, either forward to a recycling center or contact your nearest ADInstruments representative for methods of disposal at the end of its working life.



WEEE Directive
symbol

Overview

This Owner's Guide covers the components of the Human NIBP System, which includes ADInstruments LabChart® software.

The Human NIBP (Non-Invasive Blood Pressure) System performs continuous, non-invasive arterial blood pressure measurement on human fingers, using switching between two finger cuffs, combined with hydrostatic height correction to correct for pressure changes when the measured hand moves away from heart level.

The Human NIBP System comprises:

- The Human NIBP Controller and Wrist Unit,
- A S (HCU),
- LabChart Pro®, and
- Two Finger cuffs, which are available in three sizes: small, medium, and large. If required, these may also be purchased separately.
 - Small, for finger circumferences 45-55 mm.....[MLE1057]
 - Medium, for finger circumferences 55-65 mm....[MLE1058]
 - Large, for finger circumferences 65-75 mm.....[MLE1059]

The Human NIBP Controller is manufactured by Finapres Medical Systems B.V. (FMS) for distribution by ADInstruments, and for use with ADInstruments software.

Checking Human NIBP Components

The Human NIBP components pass quality control inspection before leaving the factory. However, there is a small chance that damage may occur in transit.

1. Check there are no obvious signs of damage to the outside casing.
2. Check there are no obvious signs of internal damage (like rattling).

If you find a problem, please contact your ADInstruments distributor immediately.

The Human NIBP Controller

The Human NIBP Controller contains a computer board and electronics for the servo-controlled finger cuff pressure. It also contains the air circuitry comprising a compressor and pressure control devices.

Note: The Human NIBP Controller has a narrow temperature operating range (see Operating Conditions) and should be placed apart from other equipment for optimal operation.

The Front Panel

Figure 1–1
Human NIBP Controller
Front panel

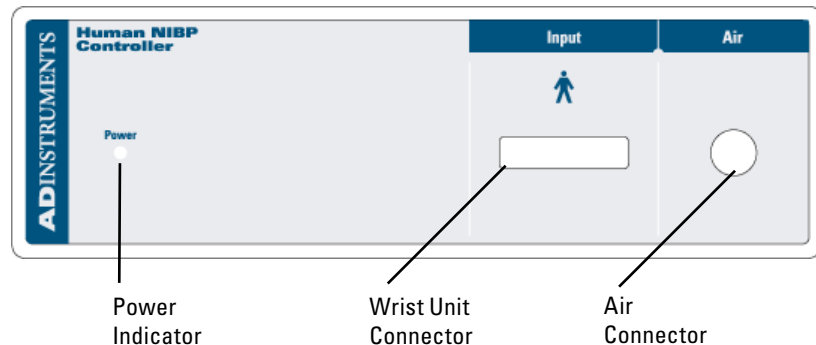

The Power Indicator

The Power indicator will light when the unit is on. If not, check that the unit is properly connected to a power socket and is switched on.

Wrist Unit Connector

This port provides the main connection for the Wrist Unit, which is a box to be worn on the back of the hand or the wrist and contains connectors for the finger cuffs and the Height Correction Unit.

Air Connector

This port is also for connection of the Wrist Unit to the Human NIBP Controller.

The Back Panel

Figure 1-2
Human NIBP Controller
Back panel

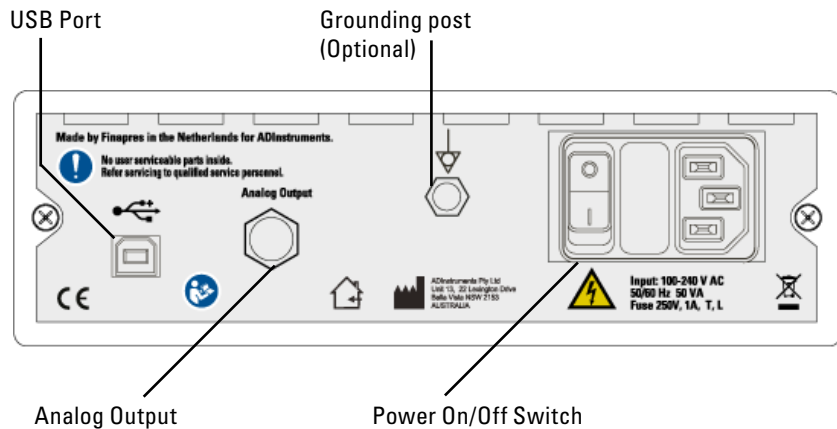

USB icon and port

USB Connection

The Human NIBP Controller has a USB port, which connects to a computer with USB ports or a PCI USB card installed, allowing high data transfer rates. Your Human NIBP Controller is supplied with a high-speed USB cable.

For proper use and reliable results, the Human NIBP Controller needs a high-speed USB connection. In practical terms this means cables between any USB devices must be no more than 5 meters (16 feet) in length. If you replace the USB cable, buy a high-speed cable (fully shielded, twisted-pair and standard USB connections: a narrow rectangular plug at one end and a square plug with a bevelled top at the other).

Analog Output Socket

The Human NIBP Controller is designed as a stand-alone unit, to receive power and to output signals via a USB connection to an attached computer. In this way, it can function without an ADInstruments PowerLab.

However, an analog output with a BNC connector is provided, allowing the option of connecting the Human NIBP Controller to a PowerLab or similar recording device. The signal at the analog output of the Human NIBP Controller is the raw Finger Pressure signal, which is nearly the same as the signal recorded into the Finger Pressure channel in LabChart as long as the measured hand is kept at heart level (the signal in the Finger Pressure channel has the hydrostatic height correction applied to it).

If the analog output is connected to an input of the PowerLab, the signal can be sampled at up to 200 kHz, depending on your model of PowerLab, and recorded into a new channel in LabChart. With the Human NIBP Controller, you are limited to a sampling rate of 200 samples per second. To sample at higher rates using the PowerLab, it is necessary to set the PowerLab as the master device in the Device Discovery dialog. See the LabChart Help for further information.

Ground Connection

An earthing (grounding) stud is provided on the rear panel of the Human NIBP Controller. This is an equipotential bonding connection post compatible with the DIN 42801 standard. The earthing stud is directly connected to the earth pin of the power socket and the Human NIBP Controller chassis. It is used as a primary earth connection (equipotential connection point) in situations that require this type of connection, for example where there is no ground connection provided via the power supply. Safety standards in laboratories and similar environments may require additional grounding protection when connecting equipment to human subjects, and their relevant standards or guidelines should be observed.

Power Socket

It is recommended to always use the grounded 3-wire electrical cable provided with the Human NIBP Controller to connect the power socket to a properly grounded mains power supply.

On/Off Switch

The Human NIBP Controller should be powered on and off using the On/Off switch on the back panel of the unit. Note that in the Human NIBP Controller, the USB and main board are powered separately. This means that



Equipotential connection point: Grounding post

disconnecting the mains power to the device does not disconnect the device from Windows.

Symbols

A number of symbols are shown on the back panel.



CE Mark. The Human NIBP Controller and ADInstruments PowerLab systems carry the CE mark and meet the appropriate EU directives.



Read Documentation symbol. This symbol means that the supplied documentation must be consulted for operating, cautionary or safety information before using the device.



Warning symbol. This means that there are no user serviceable components in this device. There is no need to open the instrument for inspection or maintenance, and doing so within the warranty period will void the warranty.



Inside use symbol. This symbol indicates that the device is suitable for inside use only.



Manufacturer symbol. The Human NIBP Controller, Wrist Unit and Finger cuffs are manufactured by Finapres Medical Systems B.V. (FMS) for distribution by ADInstruments.



Equipotential connection point. Grounding post provided for earth connection.



Electrical hazard symbol. This symbol indicates that the unit is for connection to a mains electricity supply and sensible precautions should be taken, such as safe connection and disconnection of the power cord.



UL Mark. The Human NIBP Controller and ADInstruments PowerLab systems meet standards set by Underwriters Laboratories with respect to electrical shock, fire and mechanical hazards only, in accordance with UL 60601-1 and CAN/CSA-C22.2 NO. 601.1.

Using the Controller

This chapter guides you through installing ADInstruments Human NIBP software and connecting the Human NIBP Controller to your computer. This chapter also covers setting up the components of the Human NIBP hardware, and zeroing the Height Correction Unit.

IMPORTANT: Warnings, subject safety

- The data produced by the Human NIBP System, which includes the Human NIBP Controller and accompanying software, is intended as an adjunct in subject assessment and should not be used as a sole means for determining a subject's diagnosis.
- The Human NIBP Controller is a finger blood pressure monitor. Never use the finger cuffs on other parts of the body.
- The Human NIBP System should only be used in persons aged over 18 years.
- To maintain operator- and subject-safety, only use accessories such as finger cuffs provided by ADInstruments or Finapres Medical Systems B.V.
- The Human NIBP Controller is class B equipment according to IEC 60601-1. It should only be used with a properly grounded AC power supply.
- To maintain operator- and subject-safety, peripheral equipment that is connected to one of the Human NIBP System components should comply with IEC60601-1 and other relevant safety standards.
- For measurements longer than 1 hour, the use of finger switching between two attached finger cuffs is strongly recommended since

a prolonged measurement on one finger can be unpleasant for the subject.

- The ADInstruments Human NIBP software is designed to support the connection of a single Human NIBP Controller unit at any one time. It does not support connection of two (or more) Human NIBP Controller devices.

Install ADInstruments Software

Please follow the instructions below in the correct order.

First, install ADInstruments LabChart software

You should first install LabChart 8 on your computer. The Human NIBP Device Enabler is a software add-on for LabChart for Windows, which is compatible with Windows Vista, Windows 7 or later.

Place the LabChart Pro CD in the CD drive of your computer. The installer should auto-run. If it doesn't, see the Read Me on the CD. Follow the on-screen instructions.

Next, install the Human NIBP Device Enabler

Place the CD for the ADInstruments Human NIBP Device Enabler in the CD drive of your computer. The installer should auto-run. Follow the on-screen instructions. Alternatively, download the Device Enabler via LabChart Feature Manager.

Then, connect the device to a computer

1. When you have installed the software, connect the Human NIBP Controller to your PC or laptop using the USB cable supplied with the device.

Note: Windows may display a message to indicate that the device driver is being installed. The device driver is incorporated in the Human NIBP Device Enabler. It uses a FTDI Virtual COM port (VCP) driver.

2. Connect the Human NIBP Controller to a grounded AC power supply using the power cord provided, then power the unit ON.



Check the installation



Figure 2–1
LabChart icon

To check the software and driver installation, ensure the Human NIBP Controller is connected to your computer and powered on. Launch LabChart by double-clicking on the LabChart icon on your Desktop.

On start-up, LabChart performs a device discovery process. It should automatically detect the Human NIBP Controller device. If a dialog like the one shown on the left of Figure 2–2 appears, click **Device Scan** to repeat the device discovery process. Once the Human NIBP Controller is found, click OK to launch LabChart.

If this dialog persists, check that the Human NIBP Controller is connected to your computer and powered on. See “Troubleshooting” for further information.

Figure 2–2
Human NIBP Controller not found by LabChart.

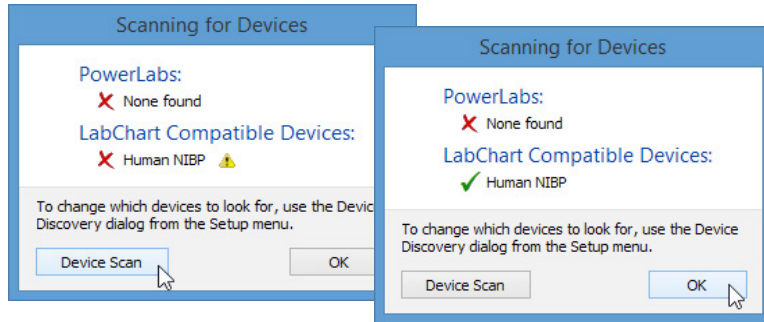

Open a new document such as the ‘Human NIBP’ settings file provided for you. This is located in the Getting Started tab of the Welcome Center, which appears when LabChart opens.

Figure 2–3
Getting Started tab of the Welcome Center.

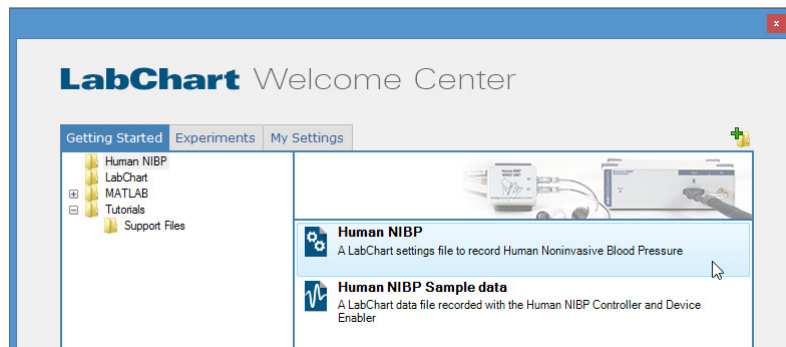

To confirm that LabChart has found the Human NIBP Controller:

- The device name should appear at the top of the new document.
- The Input Amplifier dialog should be disabled for all 11 LabChart channels because data is streamed directly from the Human NIBP Controller. There is no need to change the settings, range or display (see the LabChart Help for more details).
- The **Start** button should be enabled and ready to start recording.

It is necessary to set up the hardware before proceeding to make a finger blood pressure measurement. If you are already familiar with the hardware, please proceed to Starting up the software on page 24.

The Human NIBP Wrist Unit

The Wrist Unit (Figure 2–4) contains an air pressure control valve, a pressure transducer, electronics for the infrared photoplethysmograph in the finger cuff, and electronics for the Height Correction Unit (HCU).

The Wrist Unit is connected to the Human NIBP Controller with a cable assembly in which the cable and air tubing run in parallel. The air tubing connects the Wrist Unit to the controlled pressure source in the Human NIBP Controller.

The cable assembly and air tubing connect to the front panel of Human NIBP Controller. A screwdriver is provided to secure the cable assembly to the front of the Controller.

Figure 2–4
Human NIBP Wrist Unit
with two finger cuffs
attached.

Note: the HCU (black) is
also shown

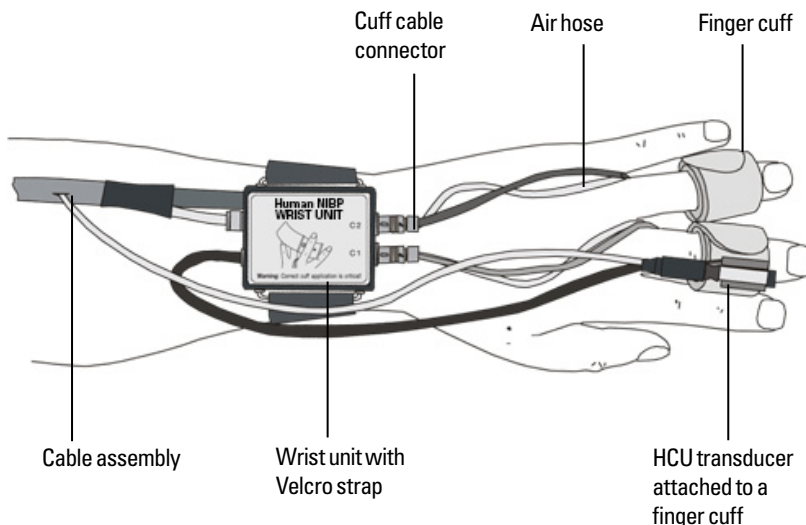

Connecting the Wrist Unit

1. Apply the Wrist Unit to the volunteer's wrist and fasten the strap firmly so that it cannot twist. It is recommended to use the non-dominant arm.
2. Guide the cable assembly along the arm and fasten the arm straps.
3. Ensure the cable assembly and air tubing are connected to the Human NIBP Controller. A screwdriver is provided to secure the cable assembly to the front of the Controller.
4. The Wrist Unit has attachment points for two finger cuffs, C1 and C2. Each finger cuff attaches to the Wrist Unit by a cuff cable and an air hose. If you choose to use a single finger cuff, its cuff cable and an air hose should be connected to C1.
5. Do not attach finger cuffs to the Wrist Unit until you are ready to start a measurement! This will avoid risk of accidental inflation and damage to the finger cuff(s).

Note. It is generally easier to wrap the finger cuffs first, before attaching them to the Wrist Unit.

The Height Correction Unit (HCU)

The Height Correction Unit consists of a liquid-filled tube connected at one end to a pressure transducer, called the HCU transducer (Figure 2–5). The other end is closed with a very pliable plastic bag contained in a small cylindrical housing, hereafter called the Reference end. During a measurement, the HCU transducer should be placed at the measured finger and the Reference end at heart level. Thus, any height changes of the measured finger are continuously sensed.

The Height Correction Unit should be connected to the rear of the Wrist Unit by a telephone connector (see Figure 2–5, inset).

To connect the HCU:

1. Fix the Reference end of the HCU to the subject at heart level, by attachment to the clothing or to a Velcro strap (see Figure 2–5). This point of attachment should allow for easy detachment for zeroing to be performed (see Human NIBP Settings on page 26).
2. The HCU transducer should be fixed to a finger cuff.
3. Ensure the HCU is connected to the rear of the Wrist Unit.
4. The tubing for the HCU should be free of any bends and unobstructed in any way.

Figure 2-5
Attaching the HCU to
the Wrist unit (top) and
components of the HCU
(bottom).

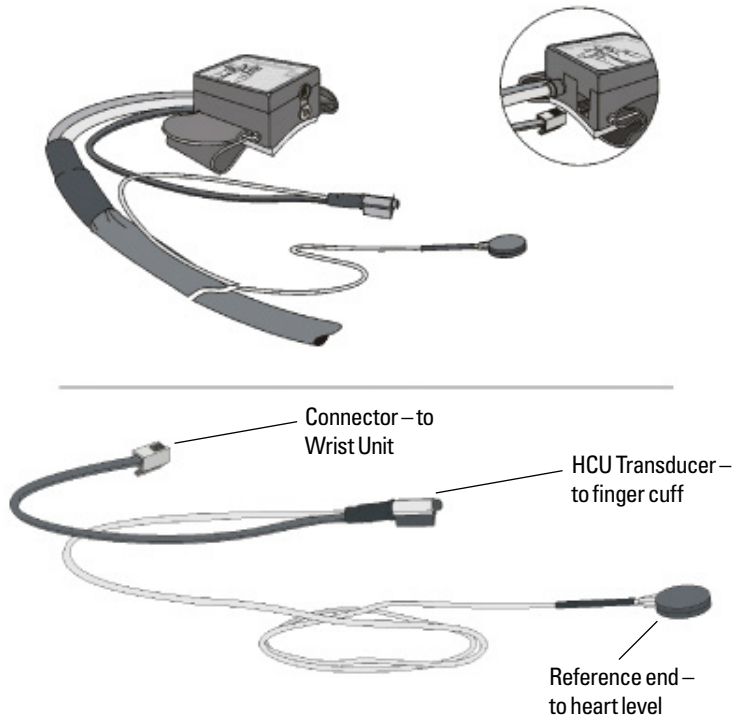
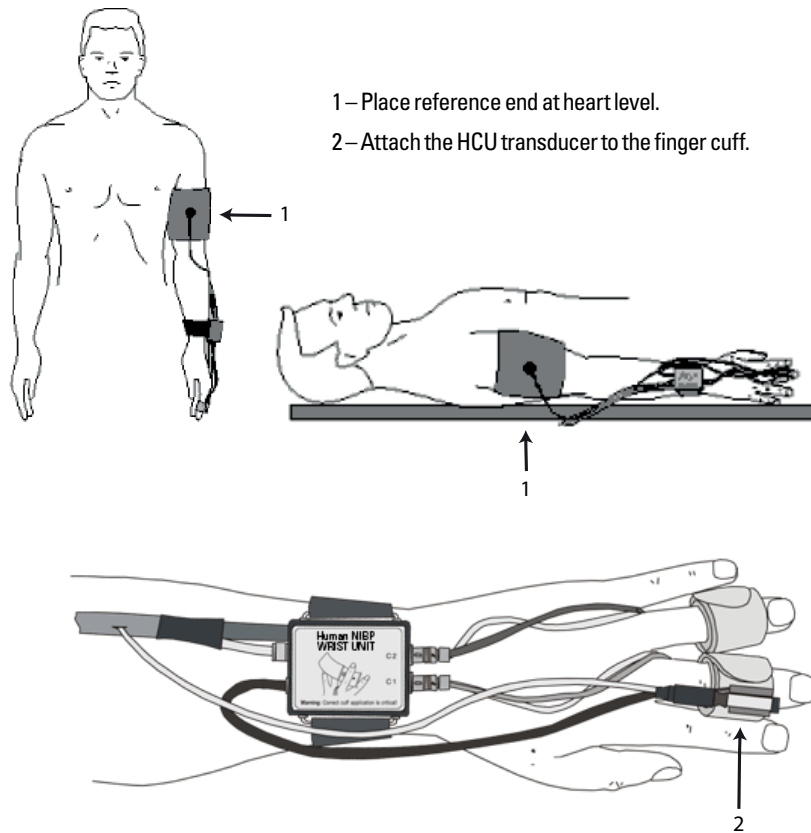

Figure 2-6
Final placement
of the Height
Correction Unit
(HCU)



Using Finger Cuffs

Proper finger cuff application is critical to successful finger arterial pressure measurement with the Human NIBP Controller. Therefore, read the following sections about finger cuff handling, selection and application with special attention!

Warnings on cuff handling

Take into account the following notes to prevent finger cuff damage:

- Don't apply air pressure to a finger cuff when it is not wrapped around a finger (or any other solid object!). This will damage the finger cuff.
- Don't bend finger cuffs outwards into a flat shape since this may damage the bonding and the electrical shielding. Finger cuffs are preformed around a conical mandrel during manufacturing.

- Do not attempt to repair defective finger cuffs (for example, with adhesive tape) as this will substantially affect measurement accuracy.
- Don't remove the finger cuff from a finger before stopping the measurement. After a measurement is complete, you should disconnect the air hose from the Wrist Unit and unwrap the finger cuff. This will prevent accidental damage to the finger cuff. The Human NIBP Controller automatically takes pressure away when the finger cuff is unwrapped.

The Finger Cuff

The main components of the finger cuff are an inflatable air bladder, and a plethysmograph consisting of a light source and a light detector. The light source is a LED (Light Emitting Diode) emitting infrared light. The light detector is an infrared photodiode (Figure 2-7).

The air bladder is connected to the Wrist Unit via an air hose. Both components of the infrared plethysmograph are connected to the Wrist Unit via a cuff cable.

Figure 2-7
The components of a
finger cuff.

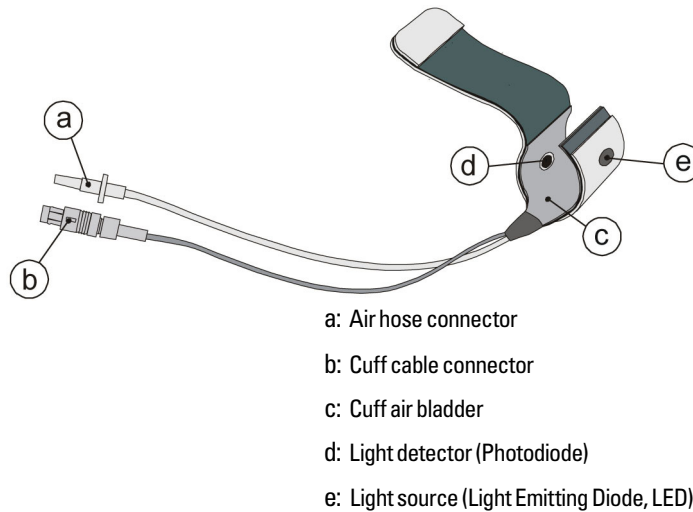

Selecting the appropriate finger cuff size

Finger cuffs are available in three sizes: small (white), medium (beige) and large (blue). A cuff size guide is included to indicate which finger cuff size is appropriate.

To obtain good transmission of pressure from the air bladder to the underlying tissues, both sides of the air bladder should just make contact.

Figure 2–8
Finger cuff sizing

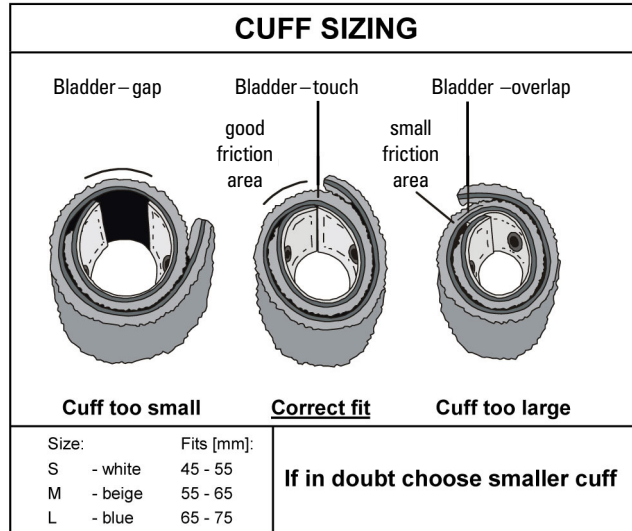

Wrapping the cuff correctly

A finger cuff should be wrapped around the middle phalanx of a finger. Best results are obtained on the middle finger and the ring finger although the index finger can be used almost equally well. Finger cuffs are not designed for application to the thumb. Only apply a finger cuff to the thumb when it is impossible to measure finger arterial pressure on any other finger and be aware that incorrect blood pressure readings may result.

Figure 2–9
Applying the finger cuff.

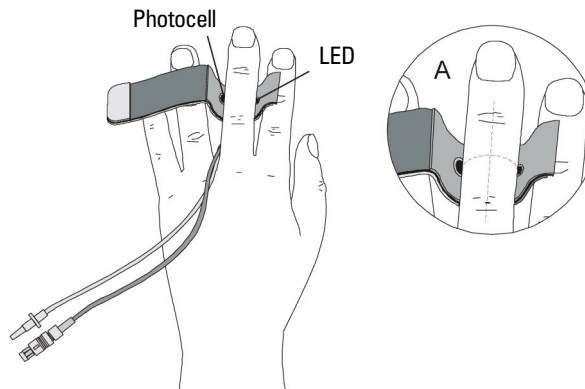

To wrap a finger cuff around the finger:

1. Open the finger cuff just enough to be able to see the LED and photodiode (or photocell, PC).
2. Place the finger in the cuff such that the LED and photocell are symmetrically placed on each side of the finger's soft parts in the center of the middle phalanx.
3. Lead the cuff cable and air hose in between two fingers to the back of the hand to reach the Wrist Unit.
4. Make sure the finger cuff is placed centered between two knuckles, touching each knuckle.
5. Wrap the finger cuff tightly for best performance. The finger cuffs are designed in such a way that correct wrapping is almost natural. Check that it is not easy to rotate the finger cuff after application. A common mistake is to not wrap the finger cuff tight enough.
6. Run the cuff cable and air hose between the fingers and insert into the Wrist Unit, which is worn on the wrist (see Figure 2-4 on page 16).
7. Repeat steps 1 to 6 for a second finger.

Connecting the Finger Cuffs to the Wrist Unit

1. A cuff cable connector and an air hose connector connect each finger cuff to the Wrist Unit. It is easier to connect these *after* the finger cuff has been applied to the finger.
2. The Wrist Unit has attachment points for two finger cuffs, C1 and C2, which permits finger cuff switching for longer duration measurements.
3. If you are using a single finger cuff, attach it to C1. Do not attach a second finger cuff to the Wrist Unit to avoid risk of accidental inflation and damage to the finger cuff.

Before making a measurement

Ensure the proper finger cuff size is selected by using the guide (see Figure 2-8). If in doubt, choose the smaller size finger cuff. It is a common mistake to wrap a cuff not tightly enough around a finger. In particular, application of white (small) cuffs to small fingers requires some skill.

To obtain good transmission of pressure from the air bladder to the underlying tissues, both sides of the air bladder should just make contact with one another, as shown in Figure 2-9 on page 21.

Figure 2–10: Cuff wrapping instructions

1. Point cable and tube towards wrist.
2. Center cuff between joints.
3. Center LED and photodiode symmetrically.
4. Wrap cuff tightly.
5. Place hand on side, thumb up.

CORRECT CUFF WRAPPING

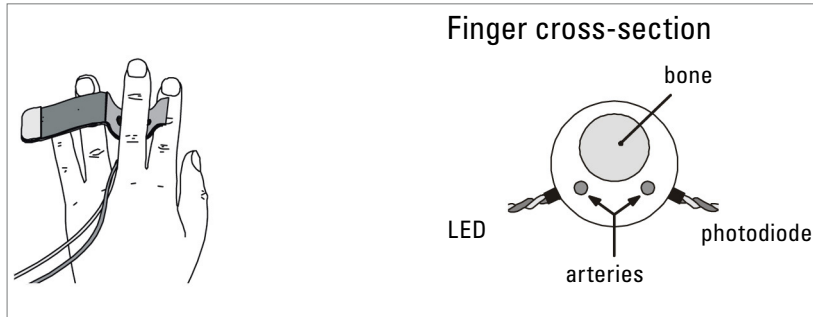

INCORRECT CUFF WRAPPING

Wrong – Cables point in the wrong direction.

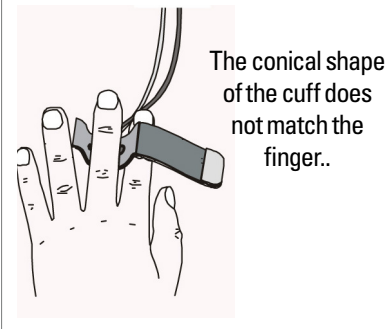

Wrong – Cuff is rotated 180°.

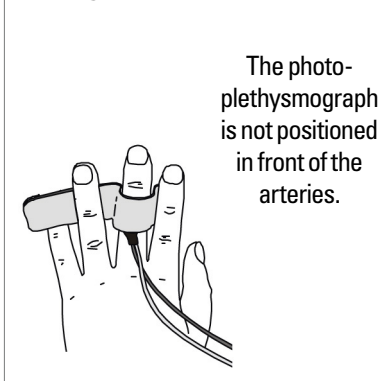

Wrong – Cuff is shifted proximally.

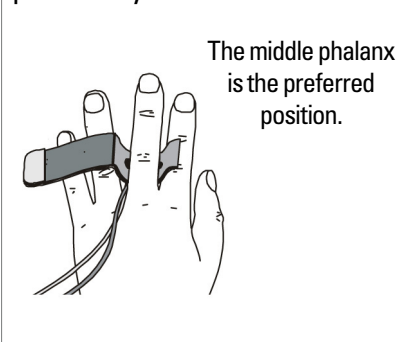

Wrong – Cuff is rotated.

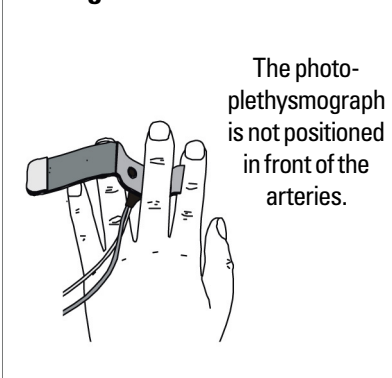

Starting up the software

Launch LabChart and open the 'Human NIBP' settings file provided for you. This can be accessed from the Getting Started tab of the Welcome Center, which opens as LabChart starts up.

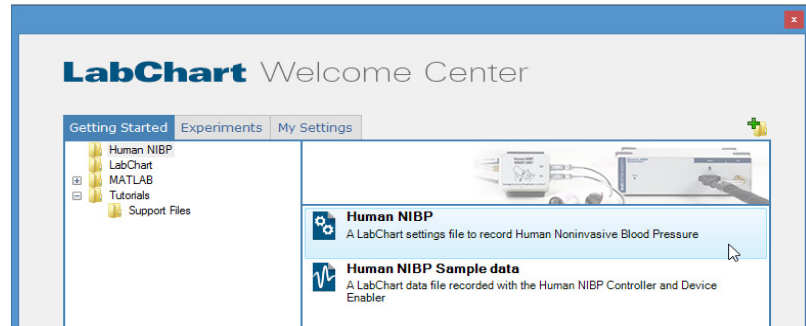

Doubling-clicking on the Human NIBP settings file opens a LabChart file with 11 appropriately-named channels. You can record data directly into this file, or you can customize this file and choose **File > Save As Settings...** to create your own Human NIBP settings file. See the LabChart Help for further details.

The Human NIBP Controller outputs the following signals:

- **Finger Pressure:** This waveform is the continuous finger pressure signal, sampled at 200 samples/second. Systolic, diastolic, mean arterial pressure, heart rate and interbeat interval are beat-to-beat signals derived from this pressure waveform.
- **HCU Pressure:** This is the pressure signal detected by the Height Correction Unit pressure transducer. The height signal is low-pass filtered and added to the Finger Pressure signal in Input 1. Thus, slow changes in blood pressure due to hydrostatic effects are compensated. However, fast movements of the measured hand may introduce motion artifacts or AutoCal errors and should be avoided.
- **Systolic (pressure):** Systolic pressure is measured as the maximum pressure level during the ejection time. Systolic, diastolic and mean pressure are updated once per heart beat.
- **Mean Arterial (pressure):** Mean arterial pressure is the true arithmetic mean pressure between upstrokes.
- **Diastolic (pressure):** Diastolic pressure is measured as the minimum pressure level immediately before the beginning of the upstroke. As systolic, diastolic and mean pressure are not available during an AutoCal, the last valid value is extrapolated during this period.

Figure 2-11
The Human NIBP
LabChart settings file
showing the 11 channels
recorded from the Human
NIBP Controller.

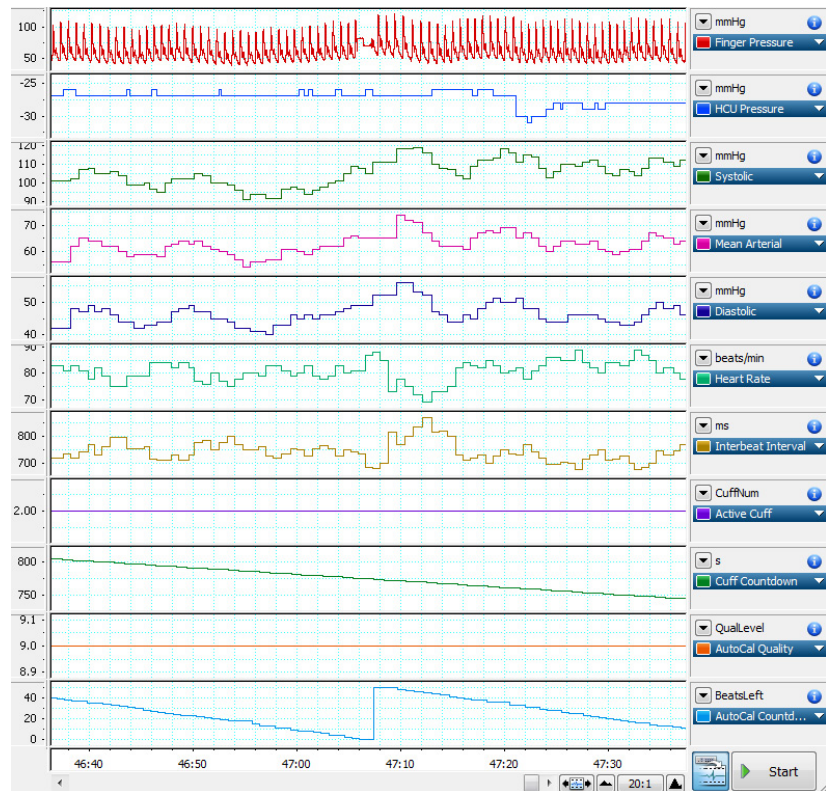

- Heart rate:** The heart rate is calculated from the number of 5 ms sample intervals, N , in a beat (the sampling rate is 200 Hz). Hence, heart rate = $(60 \times 200/N)$ beats per minute (bpm).
- Interbeat interval:** This is the period between two successive upstrokes in the Finger Pressure channel, in 5 ms resolution. This puts certain constraints on the resolution of the interval, particularly at short intervals. Note: If the pressure wave is not available, such as when an AutoCal is performed, detection is switched to the plethysmographic pulse wave. Hence, heart rate and interbeat interval are available during an AutoCal. However, during finger cuff switching, no sensible data is recorded and a zero value is returned. The calculated data (Systolic, Mean Arterial, Diastolic, Heart Rate and Interbeat Interval) is advanced by one interbeat interval value and a second to correctly align with the Finger Pressure signal.
- Active Cuff:** This indicates which finger cuff is active during that part of the recording.
- Cuff Countdown:** This channel shows the countdown of the number of seconds until finger cuff switching occurs.

- **AutoCal Quality:** This is an internal measurement of the quality of the last AutoCal performed.
- **AutoCal Countdown:** This channel shows the countdown of the number of heart beats until the next AutoCal is performed.

Human NIBP Settings

This section describes the options available in the Human NIBP Settings dialog. Go to **Setup > Human NIBP Settings...** to open this dialog.

Figure 2–12
Opening the Human NIBP
Settings dialog.

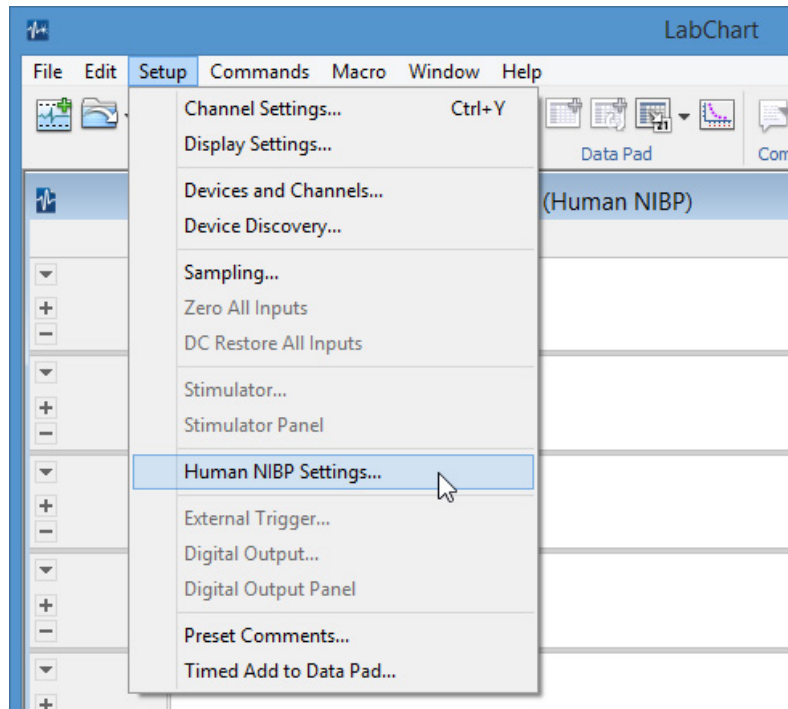

Auto calibration enabled

Auto calibration is based on a patented model for blood pressure calibration (see details of the PhysioCal algorithm on page 49). Auto calibration or 'AutoCal' is on by default. It improves accuracy in the arterial blood pressure measurement by providing an ongoing calibration, every 70 beats or so.

If the volunteer is moving around a lot, such as during exercise, the AutoCal function does not improve accuracy and should be turned off. However, it is advised not to measure for longer than 5–10 minutes with Auto calibration switched off because some pressure drift may result.

Figure 2–13
Human NIBP Settings
dialog showing default
settings.

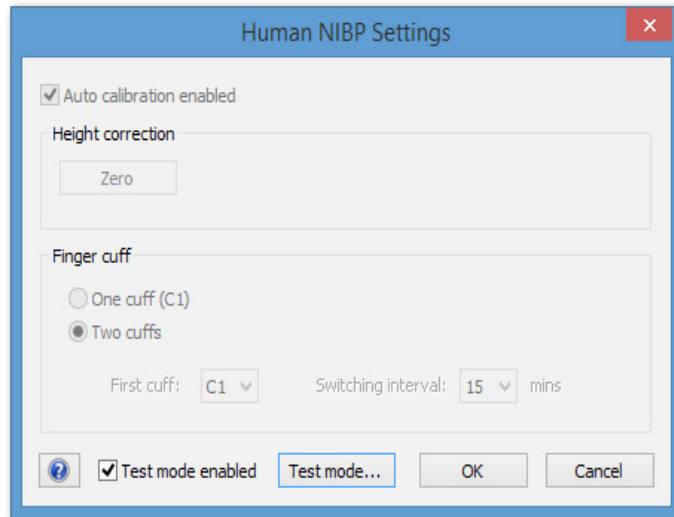

Finger cuff switching

Finger switching can only be configured in LabChart when the Human NIBP Controller is powered on and attached to your computer. Once you have started a blood pressure measurement it is not possible to initiate or delay a finger switching procedure.

To disable finger cuff switching, select **One cuff (C1)**. If finger cuff switching is disabled, blood pressure measurements will be made from a single finger cuff which must be connected to Channel 1 (C1) of the Wrist Unit.

If finger cuff switching is enabled, two finger cuffs must be connected to Channel 1 (C1) and Channel 2 (C2) of the Wrist Unit. The option to start C1 or C2 is now available, as is the option to select a switching interval.

Selecting a finger switching interval

The selection of a finger switching interval depends on the kind of measurement you are going to perform. For measurements longer than 1 hour always select finger switching, since a prolonged measurement on one finger can be unpleasant for the volunteer.

Four finger switching periods can be selected: 1, 15, 30 and 60 minutes. The 1-minute finger switching interval is for maintenance purposes only. It can also be used to get a quick impression of the blood pressure measurement in

two fingers before starting a 24 hour blood pressure measurement. However, you should realize that a measurement for only a minute will not provide a stable or reliable blood pressure reading.

The selection of one of the three remaining finger switching intervals depends on the protocol of the measurement. In the first 1-3 minutes after a finger switching procedure the blood pressure values are less reliable.

For measurements up to one hour it is also recommended to select finger switching, and to set the finger switching interval to 60 minutes. The reason for this is that, without switching enabled, a timeout error may occur. With finger switching enabled the measurement will NOT be stopped, as may occur if finger switching is disabled. With **Two cuffs** selected, the Human NIBP Controller will try to restart a measurement after a waiting period and data acquisition should not be interrupted.

Finger cuff switching should be turned off in measurements of up to one hour that you do not want to be interrupted by a finger switching procedure. Also, to avoid analysis problems due to pressure differences between fingers, it is recommended to use the same finger in measurements of up to one hour (see following section).

Relationship between finger arterial pressures in a two-finger switching measurement

Finger arterial pressures from the index, middle and ring fingers are not necessarily equal, although differences are usually small. In some measurements a pressure difference between fingers is observed. This can be caused by either physiological differences between fingers or differences in cuff application or both.

If a cuff is not wrapped tightly enough, i.e., when it is too easy to pull the cuff from a finger, blood pressure readings will be too high. This is caused by a pressure gradient over the air bladder when the air bladder is inflated too much. The Human NIBP Controller then needs to apply a higher cuff pressure to achieve the same diameter changes in the finger artery. Likewise, if a cuff is too small and is wrapped (much) too tightly, as is illustrated in Figure 2-10, blood pressure readings may be too low.

Performing the Height Correction Procedure

The next step is to apply the height correction procedure. This should be performed before attaching the HCU unit to the volunteer.

1. Hold the HCU transducer and the reference point at the same level (Figure 2-14).
2. In the Human NIBP Settings dialog click **Zero** to zero the HCU.
3. In the Settings dialog, a message will appear confirming that the HCU has been zeroed. Click **OK** in this dialog to proceed.

Figure 2-14
Zeroing the HCU.

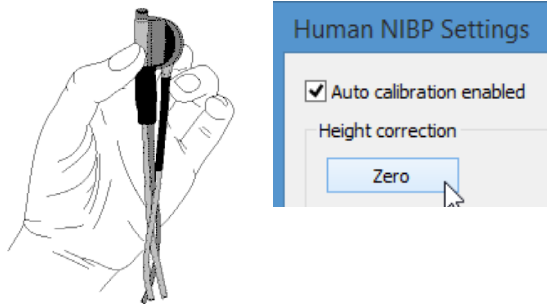

The HCU transducer should then be attached to the finger cuff using the Velcro provided, and the Reference end attached at heart level. Once zeroed, the HCU pressure is negative if the hand is below heart level, and positive if the hand is above heart level.

This offset is stored in volatile memory and will no longer be available if the Human NIBP Controller is powered off. The same holds true if the HCU is disconnected and later reconnected, or if LabChart is shut down and then restarted.

If an error message advising that the HCU “Zero failed” appears, follow the instructions to repeat the zeroing process. Comments such as “HCU not zeroed” or “HCU not connected” will be inserted into the LabChart data file if the zeroing process has not been successful.

Starting a measurement

To start a blood pressure measurement click on the **Start** button in LabChart. The following dialog will appear to remind you to ensure the finger cuff(s) are correctly attached:

Figure 2-15
Warning dialog.

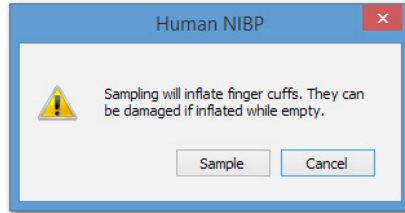

To start sampling, click **Sample**. The Warning dialog will not reappear within the same LabChart recording session. If you stop recording for any reason, simply click **Start** to resume a measurement.

Pressure staircase at the start of a measurement

During the start-up phase of a finger blood pressure measurement, the cuff pressure is increased stepwise while analyzing the plethysmogram. Based on the amplitude and shape of the plethysmogram the stepwise increase in pressure is stopped as soon as cuff pressure is above systolic pressure. Then an AutoCal is performed and the blood pressure measurement is started.

Figure 2-16
Start-up procedure applied at the start of a measurement and after finger cuff switching.

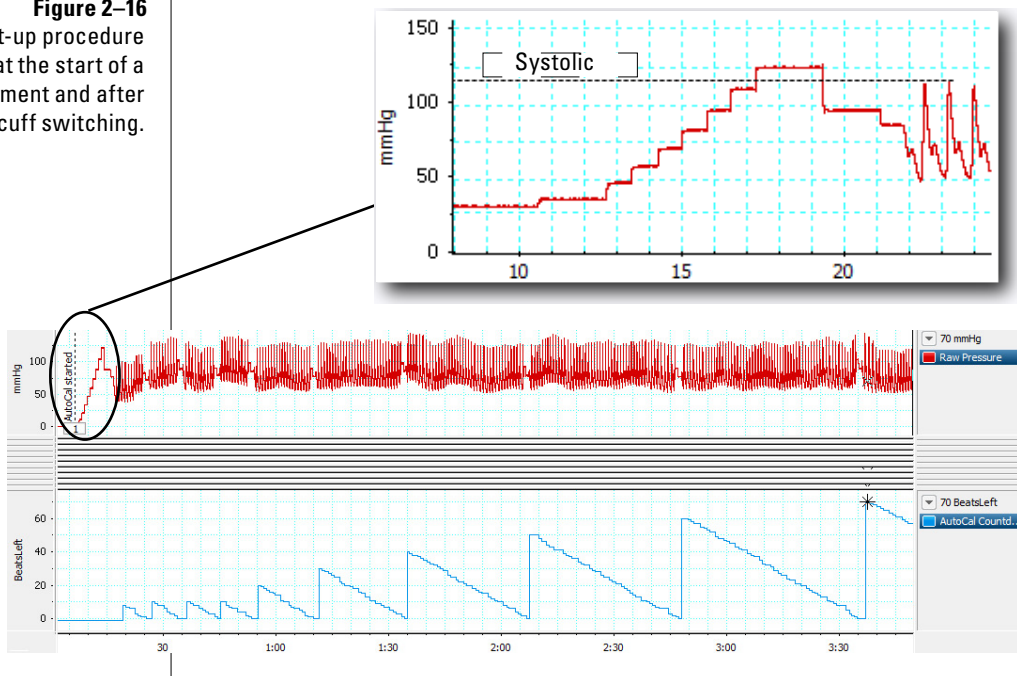

While the Human NIBP Controller is measuring finger arterial blood pressure, a slight pulsation in the cuffed finger is felt which is synchronous with the heart beat. At regular intervals an AutoCal is performed during which cuff pressure is held at constant pressure levels and no pulsation can be felt for two or more beats.

AutoCal frequency

In the first one or two minutes after the start of a finger blood pressure measurement the Human NIBP Controller device has to deal with the emptying of small microvessels from blood under the cuff. The absorption of the light between light source and light detector usually decreases due to this effect. This change in absorption has nothing to do with the unloaded diameter of the finger artery and is compensated for by the Human NIBP Controller. Since this effect is more pronounced immediately after starting a blood pressure measurement, an AutoCal procedure is scheduled initially after every 10th heart beat. Once the setpoint has become sufficiently stable this interval is gradually increased to 70 beats, normally within 4 minutes.

Stopping a measurement

To stop recording simply click **Stop** in LabChart.

Once you have completed a measurement, it is recommended to:

1. Disconnect the finger cuff air hoses from the Wrist Unit – this removes any residual air pressure from the finger cuffs and protects the finger cuffs from accidental inflation and damage.
2. Unwrap and remove the finger cuffs and take the Wrist Unit away from the subject.

If the Human NIBP Controller is returning error messages or failing to start a measurement, it is best to disconnect the finger cuff air hoses from the Wrist Unit, turn the Human NIBP Controller off and back on, reapply the finger cuff(s) and restart the LabChart software before resuming a measurement.

When you remove a finger cuff after stopping a measurement, it is recommended to inspect the finger to see if you can find the place where the two components of the plethysmograph have pressed on the finger skin. Usually, some coloring of these pressure points can be seen immediately after removing the cuffs. Verify that the pressure points were correctly centered between the knuckles and symmetrically placed.

Use of comments

With the ADInstruments Human NIBP software installed, LabChart enters comments automatically when finger cuff switching occurs, for example ‘Switching to finger cuff 2’, and when the HCU is not zeroed or connected.

When finger cuff switching occurs, no sensible data is recorded for a period of almost 30 seconds, and blood pressure measurements in the 1–3 minutes following finger cuff switching are less reliable. Hence, these comments can be useful when analyzing large data files. For example, by using **Commands > Multiple Add to Data Pad...** and selecting **Find Using: Comment**, you can automate your analysis to the Data Pad, which is an Excel-like spreadsheet embedded within LabChart. See the LabChart Help for further details.

Figure 2–17
Multiple Add to Data Pad dialog showing suggested analysis settings.

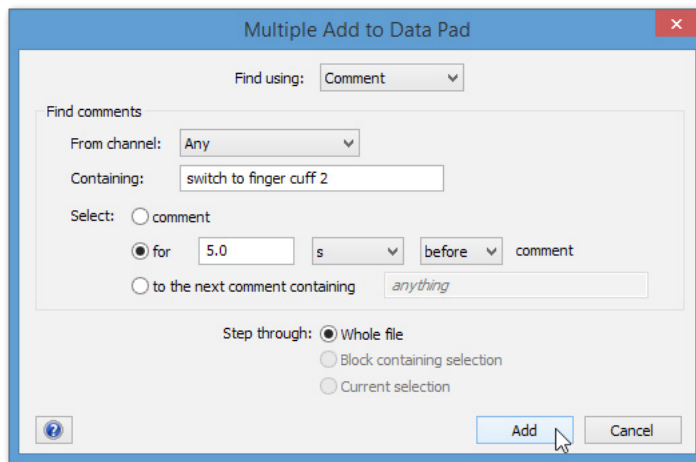

Test mode

Test mode is a useful feature because it can be used to verify that the Human NIBP Controller is working correctly. Furthermore, in Test mode the Human NIBP Controller generates pressure signals that can be used to calibrate a chart recorder or another system.

To go into Test mode:

In the Human NIBP Settings dialog, click on the **Test mode** button. Select one of the options from the Test Mode dialog and click **OK**. On return to the Human NIBP Settings dialog you will notice that:

- Auto calibration is disabled as there is no valid data to calibrate.

- Finger cuff switching is also disabled – the pressure waveforms generated are applied at the C1 air hose outlet on the Wrist Unit.
- The Test mode button has changed to indicate that Test mode is on.

Figure 2–18
Human NIBP Test mode dialog (right) showing available options, and the Human NIBP Settings dialog (left) showing AutoCal and finger cuff switching options are disabled in Test mode..

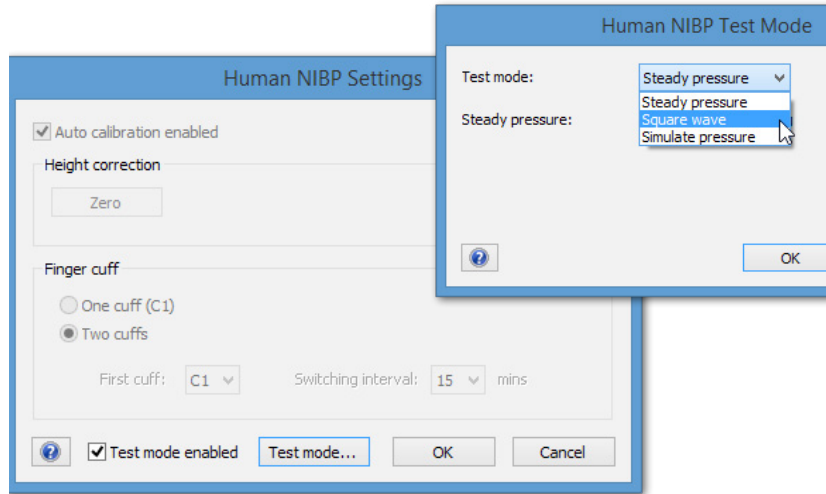

Available Test modes

1. Steady pressure – This generates a flat, constant-pressure wave. Available options are 50, 100, 150, 200, 250 and 300 mmHg.

- In this test mode it takes about 20 seconds for the Human NIBP Controller to build up to the correct mode and pressure.

Figure 2–19
Human NIBP Test Mode dialog showing the available Steady pressure options (top) and the generation of a steady pressure of 100 mmHg (bottom).

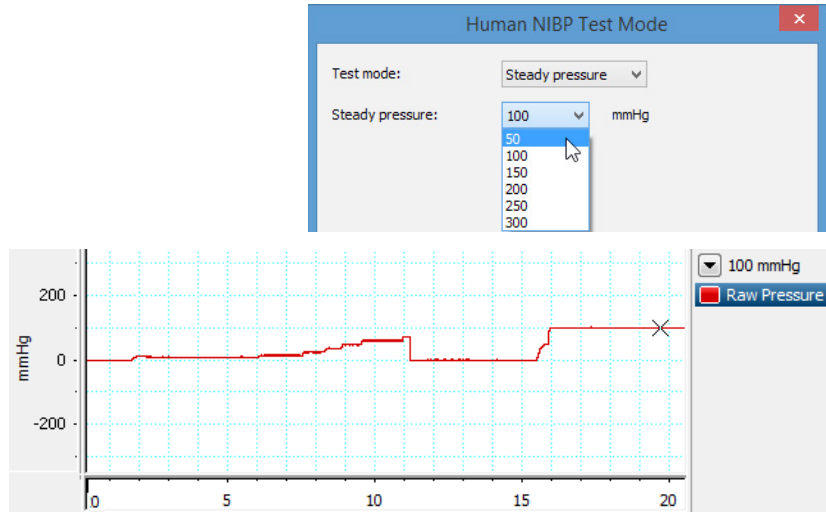

2. Square wave – This generates a repeating square pressure wave. Available baseline pressure options are 50, 100, 150, 200 and 250 mmHg, and frequency options are 1, 4 and 10 Hz. Note how, in Square wave mode, the Human NIBP Controller uses a fixed offset of ± 50 mmHg that cannot be changed.

Figure 2–20
Human NIBP Test Mode dialog showing the Square wave options (top) and the generation of a repeating square wave with a baseline pressure of 100 mmHg (bottom).

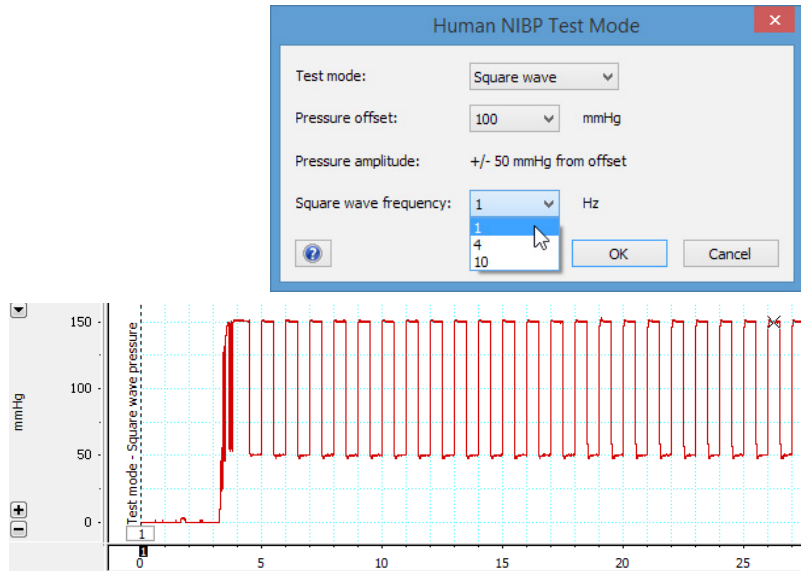

- In Figure 2–20 a pressure offset of 100 mmHg at 1 Hz was selected. The resultant square wave is 150 mmHg for 0.5 s, followed by 50 mmHg for 0.5 s, and so on.

- Therefore, if your pressure offset is 250 mmHg, what you see is 200 mmHg, then 300 mmHg. Alternatively, if your pressure offset is 50 mmHg, what you see is 100 mmHg, then 0 mmHg.
- In this test mode it takes about 20 seconds for the Human NIBP Controller to build up to the correct mode and pressure (you should feel the finger cuff pulsating erratically as it starts up).

3. Simulate pressure – the simulated pressure test mode does not inflate the finger cuffs. It creates a continuous square waveform in the Finger Pressure and HCU Pressure channels (see Figure 2–21 on page 35):

- In the Finger Pressure channel, it generates a simulated pressure wave of 2 second duration at 200 mmHg, followed by 3 seconds at 0 mmHg.
- In the HCU Pressure channel, it generates a simulated pressure wave of 2 second duration at 100 mmHg, followed by 3 seconds at -100 mmHg.

Figure 2–21
The Test Mode dialog with Simulate pressure selected.

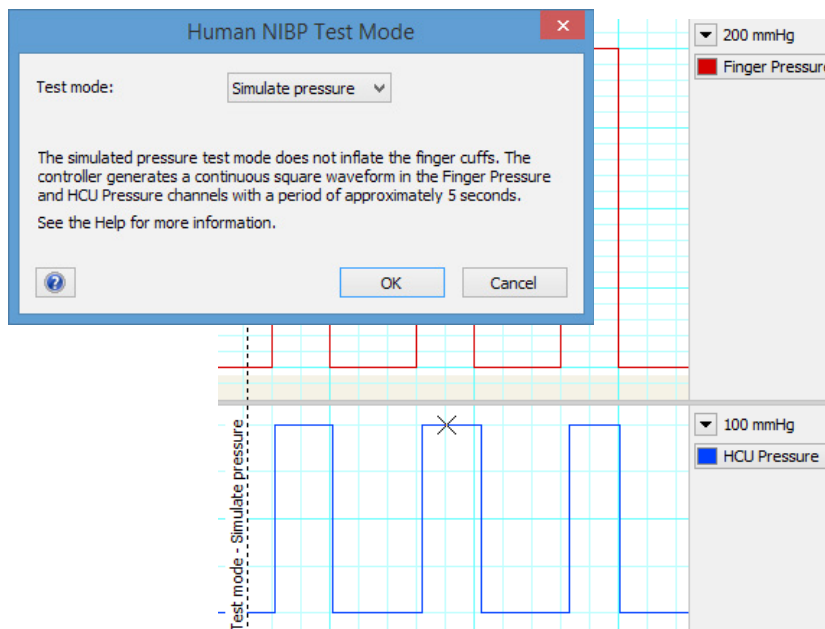

Using Test Mode

In Steady pressure and Square wave modes, the pressure waveforms generated by the Human NIBP Controller are applied at the C1 air hose outlet of the Wrist Unit.

- To initiate a recording in Test mode it is necessary to connect the finger cuff to C1 of the Wrist Unit by its cuff connector. However,

it is not necessary to attach the air hose connector of the finger cuff (see Figure 2–23). This allows one to perform a Pressure check by attaching a precision manometer to the C1 air hose outlet instead.

- In all Test modes the Warning dialog will appear the first time you click **Start**. This is a reminder not to apply air pressure to a finger cuff when it is not wrapped around a finger (or another solid object!) as this will damage the finger cuff. To start a recording, click **Sample**. This dialog will not reappear within the same LabChart session.
- In all Test modes it takes 15–30 seconds for the Human NIBP Controller to build up to the correct mode and pressure.
- The pressure signals generated by the Human NIBP Controller are also available at its analog outputs for the calibration of a chart recorder, or similar recording device.

Troubleshooting

Finger cuff application

As with many things, correct finger cuff application improves with practice, as do finger arterial pressure measurements. When initially learning how to use the Human NIBP Controller, you may find that finger arterial pressure readings are unusually high or low – this is most often due to incorrect positioning of the finger cuffs, which should be tightly wrapped, absolutely centered between the knuckles of the middle phalange, and also symmetrically placed (i.e., not rotated).

Checking measurement accuracy

Before or after a measurement, you may wish to measure your volunteer's brachial arterial pressure using auscultation or a similar, non-invasive procedure. This can be used to verify that the subject's finger arterial pressure corresponds with the subject's brachial arterial pressure. Note that these values can often differ by ± 10 mmHg for reasons discussed in the following chapter (see Measurement accuracy on page 55).

When you remove a finger cuff, after stopping a measurement, it is recommended to inspect the finger to see if you can find the place where the two components of the plethysmograph have pressed on the finger skin. Usually, some coloring of these pressure points can be seen immediately after removing the cuffs. Verify that the pressure points were correctly centered between the knuckles and symmetrically placed.

Checking measurement stability

If the Human NIBP Controller is returning error messages or failing to start a measurement, it is recommended to disconnect the finger cuff air hoses from the Wrist Unit, which removes any residual air pressure in the finger cuffs. You should then turn the Human NIBP Controller off and back on, reapply the finger cuff(s) and restart the LabChart software before attempting to resume a measurement.

Note: The Human NIBP Controller has a narrow temperature operating range (see Environmental Specifications on page 69) and should be placed apart from other equipment for optimal operation.

Subject Instructions

If blood pressure is measured on cold fingers, the measurement can be difficult or even impossible. Therefore, it is recommended to do measurements at room temperature, and to keep the hand warm during ambulatory measurements. Ask the subject to wear comfortable and sufficiently warm clothes. Make sure the subject is in an environment at room temperature at least 15 minutes before the start of a measurement, especially in winter time. It is important not only to keep the hand and fingers warm, but also the arm and neck.

Continuous blood pressure is often more variable than expected. If you are interested in a detailed blood pressure response ask the subject to refrain from speaking during the measurement and explain to the subject that movements of hand and fingers, laughing, coughing, and so on, may cause waveform artifacts in the finger blood pressure signal.

Height Correction

The height reference level should be selected carefully. If the subject is walking around or sitting it is best to place the reference part on the chest at the level of the right atrium in the mid-axillary line. In the recumbent position it is best to place the reference ending at mid chest level. If the experiment focuses on the dynamic response of the hemodynamic system after a change in posture it is usually best to keep both the transducer and the reference ending at the level of the right atrium to avoid a dynamic response of the height correction system.

As a general rule try to keep the cuffed fingers approximately at heart level, even with a connected Height Correction Unit.

HCU Unit cannot be zeroed

If LabChart is unable to start sampling and is returning error messages stating “HCU not zeroed” (or if “HCU not connected” appears in the comments log), this is due to a problem with the Human NIBP Controller. This problem is also evidenced by HCU Pressure channel showing 200 mmHg, even after repeatedly zeroing and unplugging and reconnecting the HCU unit.

Steps to carry out if you encounter this problem:

1. Try powering off and restarting the Human NIBP Controller. If this does not solve the problem, try following steps 2 and 3 below.
2. Ensure you hold the HCU transducer and the reference point at the same level before zeroing. If this does not work, carry out step 3.
3. First, close LabChart and turn off the Human NIBP Controller. Unscrew the two screws attaching the Wrist Unit to the Human NIBP Controller. Unplug the cable and then reattach it to the Human NIBP Controller. Don't disconnect the Air Connector. Then try step 1 again.

Figure 2-22
Human NIBP Controller
Front panel

Step 2

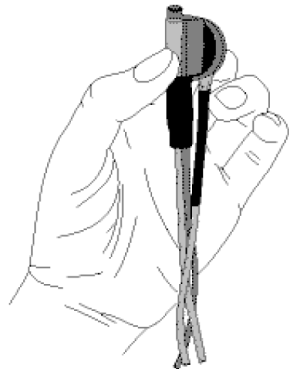

Step 3

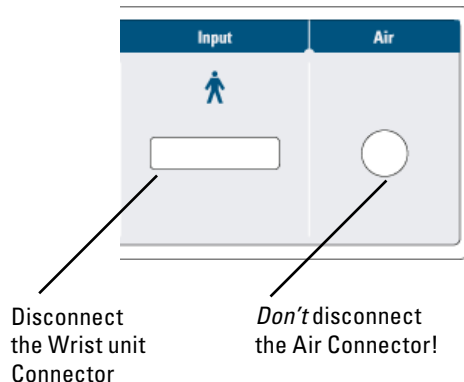

The procedure described in step 3 resets the Wrist Unit and has been used successfully to overcome certain hardware problems. Note, however, there is no need to remove the cover of the instrument, and doing so within the warranty period will void the warranty.

Connectivity issues

On the Human NIBP Controller, the USB and main board are powered separately. This means that disconnecting the mains power to the device does not disconnect the device from Windows. When troubleshooting connectivity issues, both the USB and power cable should be unplugged.

Pressure check

Pressure generated by the Human NIBP Controller should be checked at least once a year, or when there is any doubt about the validity of the finger cuff pressure readings.

To perform a pressure check:

1. Ensure the Wrist Unit is connected to the Human NIBP Controller as described in Connecting the Wrist Unit on page 17.
2. Connect a finger cuff to C1 of the Wrist Unit by its cuff connector but *do not attach* the air outlet connector.
3. Connect a calibrated precision manometer to air outlet C1 of the Wrist Unit (see Figure 2–23).
4. Launch LabChart and open the Human NIBP Settings dialog (**Setup > Human NIBP Settings...**).
5. Next, select **Test mode...** and choose the **Steady pressure** option, in which the generated pressure wave fluctuates around the baseline pressure by a fixed offset of ± 50 mmHg (see Figure 2–19 on page 34).
6. Click **Start** in LabChart, and then click **Sample** in the Warning dialog that appears. It will take around 20 seconds for the Human NIBP Controller to settle into the chosen **Steady pressure** level.
7. Click **Stop** to stop sampling and reopen the Human NIBP Test Mode dialog to select a different pressure level.
8. At each pressure level the precision manometer reading should be within 3 mmHg (1% full scale) of the selected pressure level.
9. If the indicated pressures are not within tolerance, contact your local ADInstruments representative to check the device.

Note: There is no need to open the instrument for inspection or maintenance, and doing so within the warranty period will void the warranty.

Figure 2–23
Human NIBP Controller
set up to perform a
pressure check

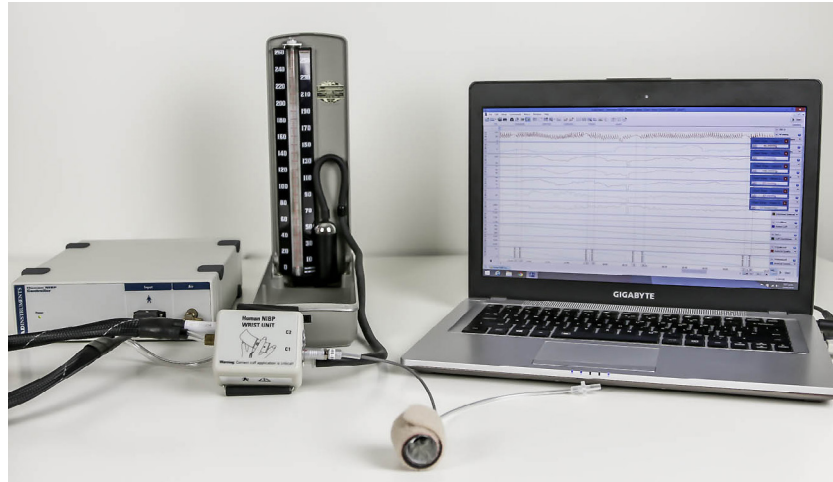



Technical Details

This Appendix describes some important technical aspects of the operation of the Human NIBP Controller. You do not need to know this material to use the Human NIBP Controller, but it is likely to be of interest to the technically-minded. In the Human NIBP software, the periodic interruption of a finger blood pressure measurement with constant cuff pressure levels to apply the PhysioCal algorithm is simply referred to as an Auto calibration or 'AutoCal'.

It should also be noted that the ADInstruments Human NIBP software is designed to support the connection of a single Human NIBP Controller unit at any one time. It does not support connection of two (or more) Human NIBP Controller devices.

This material is not intended in any way as a service guide. It should be noted that any modification or attempt to service your Human NIBP Controller voids your rights under the warranty.

How it Works

In a manner similar to Finapres®, Portapres® and the Finometer® systems (www.finapres.com), the Human NIBP Controller uses the volume-clamp method, originally described by the Czech physiologist Jan Peňáz [Peňáz 1969, Peňáz 1973], to measure blood pressure in the finger. In this method the diameter of an artery under a cuff wrapped around the finger is kept constant (clamped), in spite of the changes in arterial pressure during each heart beat.

Changes in arterial diameter, detected by means of an infrared photoplethysmograph built in the finger cuff, are opposed by a fast pressure servo controller that changes pressure in an inflatable air bladder, which is also mounted in the finger cuff. Based on the patented blood

Figure A-1
Wrist Unit, finger cuffs
and S.



Photoplethysmography

Photoplethysmography (PPG) is an optical measurement technique that is widely used to detect blood volume changes in vascular beds in a variety of tissues. A standard photoplethysmograph is a simple device consisting of a light source to illuminate the tissue, and a light detector to detect small changes in light intensity associated with variations blood volume. For the Human NIBP finger cuffs, the light source is a LED (Light Emitting Diode) emitting infrared light. The light detector is an infrared photodiode.

PPG is used in a variety of different, non-invasive clinical applications including: pulse oximetry, vascular diagnostics and blood pressure measurement. For most PPG applications, the light source utilizes visible red, near-infrared or infrared wavelengths. These wavelengths are optimal for interactions with biological tissues for the following reasons:

1. The optical properties of water: Water, the main constituent of tissues, absorbs light very strongly in ultraviolet and longer infrared wavelengths. Melanin strongly absorbs the shorter wavelengths of light. There is, however, an 'optical window' in water's absorption spectrum that permits visible red and shorter, infrared wavelengths to pass – this allows the measurement of changes in blood volume with perfusion at these wavelengths.
2. The isobestic point for hemoglobin: Oxyhemoglobin and deoxyhemoglobin differ significantly in their absorption spectra, except at their 'isobestic' wavelengths, at which the two species have the same molar absorptivity. In the near-infrared range close to 805 nm, PPG signals should be largely unaffected by changes in oxygen saturation [Gordy and Drabkin, 1957].

-
3. Depth of tissue penetration: At a given light intensity, different wavelengths vary in their depths of tissue penetration [Murray and Marjanovic, 1997].

Plethysmograph

The most commonly examined plethysmograph waveform is the peripheral pulse, which is synchronized with each heartbeat. The waveform component that varies with each pulse is often referred to as the 'AC' component, and this has a frequency of around 1 Hz, depending on heart rate. The AC component is superimposed on a much more slowly-changing component, often called the 'DC' component, which reflects the state of the tissues, average blood volume, vasomotor tone of arteries and arterioles, as well as sympathetic nervous system activity, thermoregulation and respiration. High and low pass digital filters can extract DC and AC components, if required, or LabChart's spectral analysis feature can be used to display the power of the frequencies present in a signal.

If the pressure in the finger cuff is kept constant the sudden rise in finger intra-arterial pressure during systole causes an increase in arterial diameter, which is detected as an *increase* in light absorption and thus as a *decrease* in the signal detected by the plethysmograph. With constant cuff pressure, during the diastolic phase of a beat as blood pressure declines gradually, blood is expelled from the artery and consequently the amount of light detected by the photodiode will increase again. Consequently the plethysmogram often resembles an inverted finger pulse waveform.

Figure A-2 shows an example signal coming from a finger infrared plethysmograph at five cuff pressure levels.

Figure A-2
Finger plethysmogram at five cuff pressure levels
(a.u. = arbitrary units).

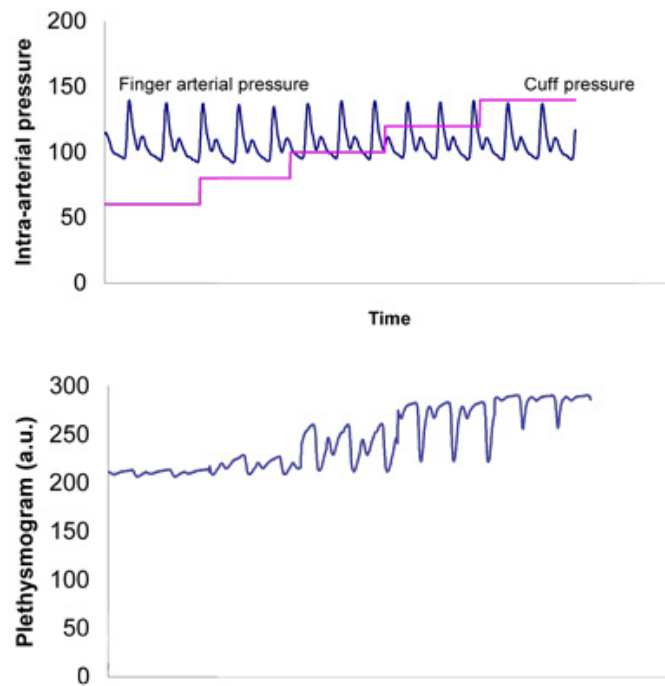

In Figure A-2 above the mean blood pressure was about 100 mmHg.

- When cuff pressure is below mean blood pressure, the arterial diameter is relatively large and therefore the plethysmographic signal is low. Since compliance is low in this state the amplitude of the pulsation is small and the plethysmogram only varies significantly during diastole.
- When cuff pressure is above mean blood pressure, the artery is collapsed during a substantial part of every heart beat. The plethysmographic signal is high (no absorption of light by arterial blood), and only varies significantly during systole.
- When the cuff pressure level equals the average intra-arterial pressure, the plethysmogram resembles an inverted pressure waveform. [Note: The end-diastolic period of the plethysmographic waveform is analyzed during an AutoCal.]
- When the top of the plethysmographic signal at end-diastole is too sharp, mean cuff pressure is below mean arterial pressure. When it is too flat, cuff pressure is too high. The shape of the plethysmogram of course also depends on the state of the artery, which depends on the smooth muscle tone (see also Figure A-3). [During an AutoCal the interpretation 'too sharp' or 'too flat' always has to be verified by analyzing the plethysmogram at one or more other pressure levels.]

The pressure-diameter relationship

The relationship between changes in arterial diameter and changes in intra-arterial pressure depends on the mechanical properties of the artery. When the artery is very compliant (low rigidity), diameter changes are relatively large, whereas diameter changes in stiff arteries are small. It is a well known fact that arterial compliance depends on the transmural pressure, i.e., the pressure difference between the pressure inside the artery and the pressure of the surrounding tissue [Langewouters 1984].

At high transmural pressures, when cuff pressure is low, the arterial diameter is relatively large. Therefore, the artery is distended and becomes stiff, causing small diameter changes. When transmural pressure is low, i.e., when cuff pressure is high with respect to mean blood pressure, the artery is almost collapsed, and diameter changes will be also small. At near zero transmural pressure, i.e., when the pressure inside the artery equals the pressure in the finger cuff, diameter changes are largest. This observation was first published by Marey in 1876 [Marey 1876]. Figure A-3 shows a stylized pressure-diameter (p-d) plot of a finger artery measured *in vitro*.

Near zero transmural pressure, the p-d curve is steepest. Therefore, for a given pressure change, the diameter change will be largest.

It is important to realize that at zero transmural pressure the artery is not collapsed. To fully collapse the finger artery requires a cuff pressure larger than the finger intra-arterial pressure. At zero transmural pressure the artery is said to be 'unloaded'.

Figure A-3
Stylized p-d diagrams of human fingers, Pt is the transmural pressure, d the diameter (a.u. = arbitrary units).

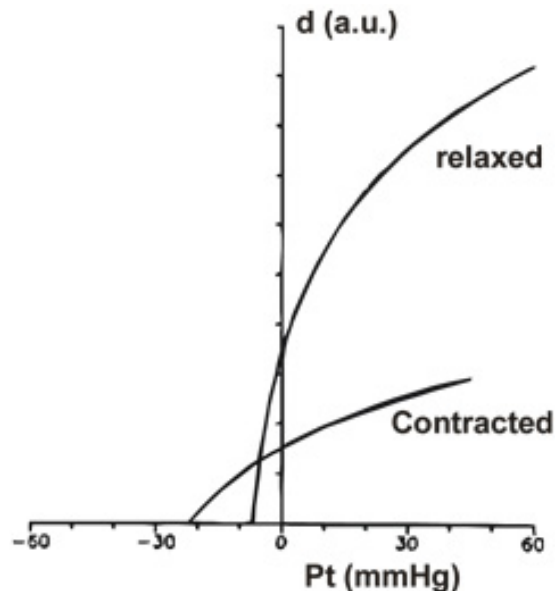

Volume-clamp method

When the volume clamp method of Peñáz is used, the finger cuff pressure is not constant but variable. The Human NIBP Controller, therefore, does not produce calibrated plethysmographs: the cuff pressure changes actually take away (most of) the plethysmogram. If during systole an increase is detected in arterial diameter, the finger cuff pressure is immediately increased by the servo-controller system to prevent the diameter change. Since the servo-controller system is designed to prevent any change in diameter, the artery is effectively clamped at a certain diameter, the 'set-point'. If this diameter corresponds with the unstressed or unloaded state of the finger artery, transmural pressure is zero all the time. Therefore, when the volume-clamp method is active at the proper unloaded diameter of the finger artery, finger cuff pressure equals intra-arterial pressure.

A servo-controller system usually defines a target value or setpoint and a measured value that is compared with this setpoint. In the servo-controller the setpoint is the signal of the plethysmogram (unloaded diameter of the artery) that has to be clamped. The measured value comes from the light detector. The amplified difference between setpoint and measured value, 'the error signal', is used to control a fast pneumatic proportional valve in the Wrist Unit. This proportional valve, modulates the air pressure generated by the air compressor, and thus causes changes in the finger cuff pressure.

The original block diagram of the method as developed by Peñáz is shown in Figure A-4. The arrows indicate a closed servo control loop. The signal V (PG) of the photoplethysmograph, consisting of a light source (L), and photocell (PC) built in a cuff (S) around the finger (F), is compared to a fixed setpoint value (C1). A difference between signal and setpoint, is amplified by DA, PID and PA, and drives the proportional valve (EPT). Cuff pressure is monitored by the manometer (M). If the switch SW is closed, the servo feedback loop is opened, and a steady cuff pressure (C2) can reach the finger.

Figure A-4
Block diagram of the
volume clamp method of
Peñáz.

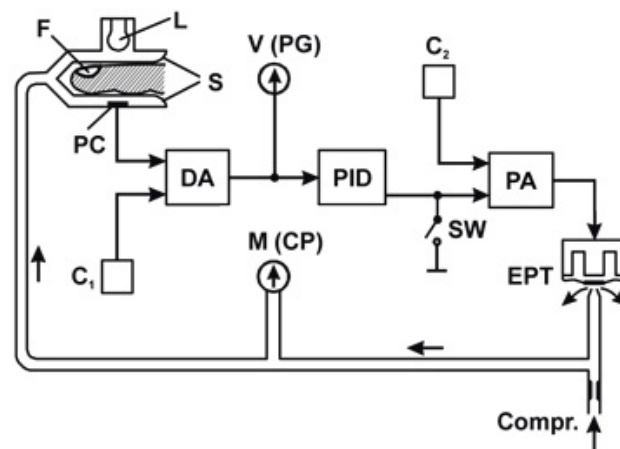

PhysioCal algorithm

The PhysioCal algorithm was developed by the Dutch physicist K.H. Wesseling and his colleagues at TNO-Biomedical Instrumentation, to enable the conversion of Peñáz's volume-clamp method into 'Finapres' (standing for FINGER Arterial Pressure) [Wesseling et al., 1995]. Their most important development was an automated servo setpoint adjuster, the PhysioCal procedure, which permitted the determination and periodic updating of the unloaded arterial diameter.

Unfortunately, defining the correct unloaded diameter of a finger artery is not straightforward. Changes in hematocrit, stress and smooth muscle tone of the arterial wall affect the unloaded diameter. Therefore, the unloaded diameter is usually not constant during a measurement and has to be verified at intervals. Periods of constant cuff pressure are used to adjust the correct unloaded diameter of the finger artery based on the signal from the plethysmograph in the finger cuff. A disadvantage of this method is that the measurement of blood pressure is temporarily interrupted during such a period. Therefore, the frequency and duration of the periods of interruption are kept to a minimum. In the Human NIBP software, the periodic interruption of a finger blood pressure measurement with constant cuff pressure levels to apply the PhysioCal algorithm is simply referred to as an Auto calibration or 'AutoCal'.

It is obvious from the previous sections that the unloaded diameter is close to the average diameter at a pressure level where the amplitude of the pulsations in the plethysmogram is largest. However, using only the amplitude of the plethysmogram is relatively inaccurate. The PhysioCal algorithm not only uses the amplitude, but also interprets the shape of the plethysmogram during periods of constant cuff pressure. By analyzing the plethysmogram at two or more pressure levels, it explores part of the pressure-diameter relation and is able to track changes to the unloaded diameter of a finger artery due to changes in smooth muscle tone.

The procedure at the start of a measurement is shown in Figure A-5. The cuff pressure is increased in standard increments to a maximum level until one heart beat is detected per level, and then decreased. The signal in the plethysmogram increases to a maximum and then decreases. The cuff pressure corresponding to the maximum signal in the plethysmogram, combined with criteria to exclude venous pulsations, produces a good indication that the finger artery is in an unloaded state. This cuff pressure is assumed to correspond to the mean arterial pressure. Once the unloaded state is established the PhysioCal procedure is carried out.

Figure A-5
 PhysioCal Start-up procedure and ongoing adjustments. The Plethysmogram trace (middle) shows more transmitted light plotted upwards. The Setpoint trace (bottom) corresponds to the total amount of light transmitted through the finger.

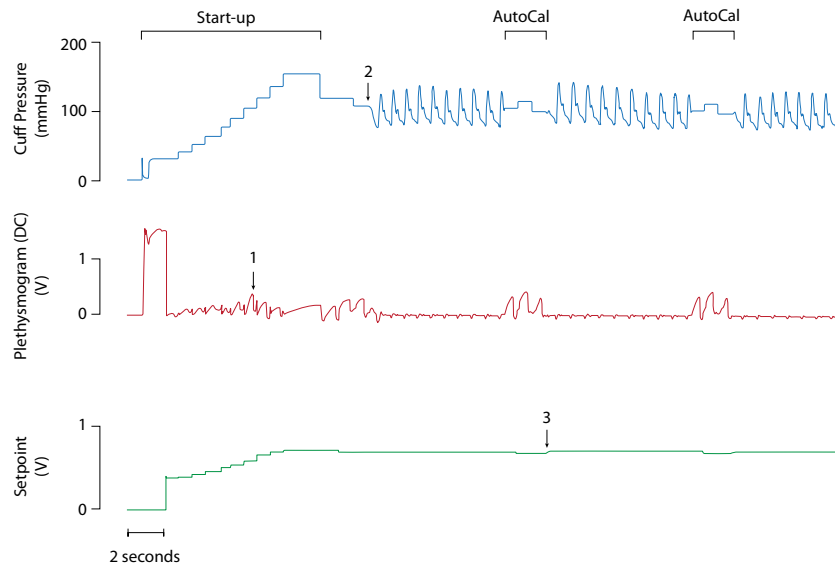

The steps below correspond to the numbers in Figure A-5 above.

1. As the cuff pressure is increased in the pressure staircase at start-up, the amplitudes of the plethysmogram signal and total transmitted light increase as blood is pushed out from beneath the cuff. At '1' the greatest plethysmogram signal is detected and the corresponding cuff pressure is 'set'.
2. At this cuff pressure, the shape of the plethysmogram waveform is analyzed and the servo setpoint is adjusted accordingly. The servo loop is then closed and finger arterial pressure measurements are taken.
3. Following 10 heart beats, the servo loop is reopened and a cuff pressure is applied that is halfway between diastolic and systolic pressures. Shapes of several plethysmogram waveforms are analyzed and the servo setpoint is adjusted to a slightly higher level. At '3' the servo loop is closed and there is a decrease in the amount of blood beneath the cuff leading to a small increase in the level of transmission.

Interruptions due to Auto calibration (or 'AutoCal') occur less and less frequently, until a 70 beat interval (roughly 1 minute) is established.

Example of a normal AutoCal

During a normal AutoCal the blood pressure measurement is interrupted immediately after the detection of the systolic phase of the heart beat. The first pressure level is located between diastolic and systolic finger arterial pressure. The shape and amplitude of the plethysmogram are analyzed and also compared with previous AutoCal periods. If the end-diastolic phase of the plethysmogram has the correct shape, an additional measurement of the plethysmogram is performed at different cuff pressure level to confirm that the determination of the unloaded volume is indeed optimal. The PhysioCal algorithm also checks that the unloaded diameter is not too close to the fully collapsed state of the finger artery.

Figure A-6
Normal AutoCals with
either two or three
pressure levels.

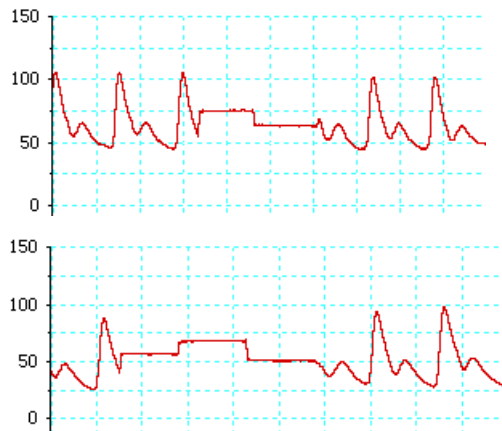

Normal AutoCals have either two or three pressure levels. However, if the correct unloaded diameter can not be confirmed during a normal AutoCal, additional pressure steps are added automatically (Figure A-7). This is usually observed immediately after starting a new measurement and when the smooth muscle tone is not stable. If these so-called multi-step AutoCals are frequently observed during a measurement, accuracy of the finger blood pressure may be reduced.

Figure A-7
Multi-step AutoCal

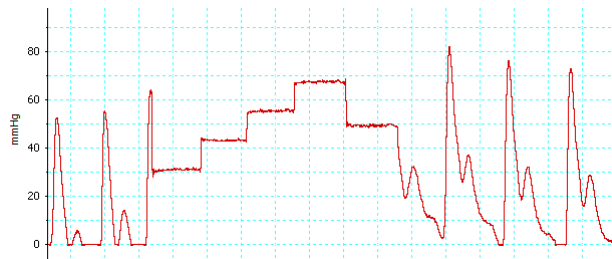

Special AutoCals with variable pressure levels

If, during a finger blood pressure measurement, the device is unable to recognize beats, the PhysioCal algorithm uses variable pressure levels instead of constant pressure levels during an AutoCal.

Figure A-8
Special AutoCal with variable pressure levels.

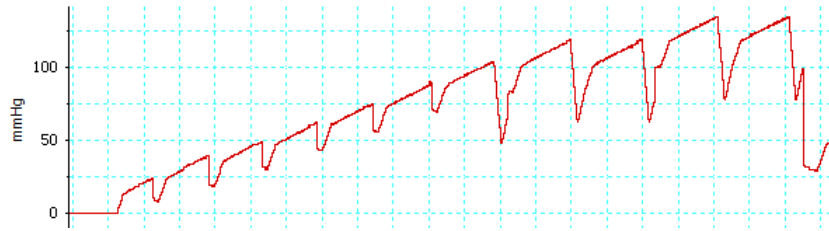

These 'special' AutoCals are performed after a period in which the software was unable to recognize heart beats, such as during movement artifacts or in situations where there is no finger arterial pressure change during a heart beat, as is the case during certain phases of open heart surgery. During a special AutoCal an inverted pressure waveform is superimposed on the constant levels. The resulting plethysmogram is used as if the finger arterial pressure was varying and not the cuff pressure.

Occurrence of oscillations

The Human NIBP Controller uses a servo system to make cuff pressure follow intra-arterial finger pressure. Servo-systems in general, and the rather complex one needed in Human NIBP Controller in particular, may show oscillations occasionally. Two types of oscillation can be distinguished, the low on/off or 'railing' type and the high frequency sinusoidal type. The presence of oscillations of either type is detected by the device and appropriate measures are taken when possible.

In the case of a railing-type oscillation, pressure may be switching from almost zero to almost full cuff pressure. If this occurs the servo setpoint and the loop gain are automatically reduced until railing stops. However, a correct measurement is no longer guaranteed until after the next AutoCal.

Figure A-9
Example of finger pressure changes during a 'railing'-type oscillation of the servo system.

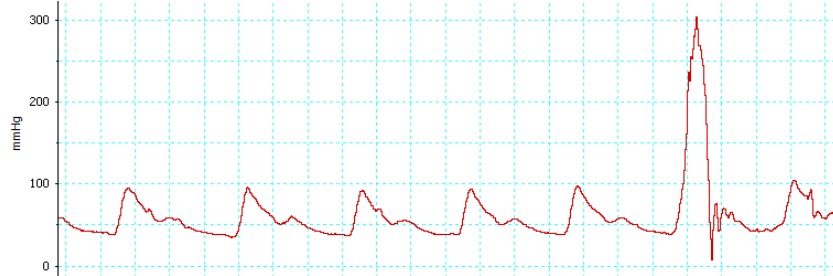

Railing, if it occurs more than just occasionally in a measurement, is almost always a sign of a cuff wrapped too loosely or a cuff too wide for the finger. Stop the measurement, rewrap the finger cuff, possibly on a different finger and then restart.

In the case of high frequency oscillations the servo system loop gain is automatically reduced until oscillations stop, and an extra servo controller filter may be switched in. An AutoCal is scheduled after two beats to confirm the setpoint and servo-system loop gain. After oscillations stop the loop gain is brought back up if necessary to guarantee sufficient gain for a proper waveform measurement. This 'gain-up' process may take several heart beats to complete.

The number of beats between AutoCals gets lower if, during an AutoCal, the Human NIBP Controller didn't get a good signal

The AutoCal frequency follows a fixed pattern unless there are problems getting a good signal. The standard number of beats between AutoCals generally follows the pattern 10, 10, 10, 20, 30, 40, 50, 60, 70 and then stays at 70 beats thereafter. Occasionally, if there is a temporary problem in the signal, the counter may go down by 2 or 3 beats during the interval before the next AutoCal. After an AutoCal countdown, the next AutoCal is performed and the result of this is used as adjustment for the following countdown.

Hence, if stability of the setpoint cannot be confirmed – for example, if there are movement artifacts or if the change in setpoint is considered too large – the frequency of AutoCal will increase automatically.

A note on blue fingertips

During a normal finger blood pressure measurement some coloring of the finger tip distal from the finger cuff is observed. The arteries below the finger cuff are unloaded, that is, the arterial walls are held at zero transmural pressure and they are therefore at their unstressed diameter (see also Figure A-4). Unstressed arteries still have about 60% of their original distended diameter or approximately 1/3 or 1/2 their original cross-sectional area and volume. The other blood vessels below the cuff are collapsed. Therefore, all the vessels behind the cuff, in the finger tip, are at instantaneous arterial pressure including the micro-circulation and the veins. Thus blood entering the finger tip during systole can only leave during diastole, when the pressure in the vessels of the finger tip is higher than the pressure more proximal from the cuff. This causes some congestion.

During a blood pressure measurement, the blood in the finger tip is less efficiently refreshed. The reduced washout of metabolites and increased de-

oxygenation of the venous blood causes blue finger tips. Note, however, that the PhysioCal algorithm always checks that the artery is sufficiently open during a measurement. Inflow and outflow from the venous compartments is facilitated by the enlarged capillary diameters at the arterial pressures their walls sustain. It is also facilitated by relaxed arterioles (including the arterio-venous anastomoses). Relaxed arteries are present in the absence of sympathetic nervous tone, vasopressors, or cold. Relaxed arterioles and a normal colored finger tip are seen frequently during normal sleep.

Gravenstein [1985] reported a substantial capillary oxygen pressure remaining in the finger tip distal of a finger cuff from 49 to 58 mmHg (compared to 80 mmHg normally) and pulse oximeter saturations of about 93%, albeit with much variability.

With all vessels in the distal finger tip at arterial pressure, one would expect an increasing diameter of that part of the finger, since at high capillary pressure increased leakage of liquid through capillary pores is expected to fill the interstitial space, however this has not been observed. A slight decrease of finger diameter under the cuff is usually observed after a prolonged period of blood pressure measurement. This decrease in finger diameter can be attributed to interstitial liquid being pressed out into the capillaries and the lymphatic system, to return to the veins.

Also, red blood cells trapped in the micro-circulation by the applied cuff pressure have been observed to wash out in a period of several minutes.

Although this evidence does not prove that damage to the finger monitored with Human NIBP Controller cannot occur, no problems have been apparent since the introduction of finger blood pressure measurement in the early 1980s.

In order to avoid long lasting congestion or discomfort, the Human NIBP Controller is equipped with a two-finger switching mode that can automatically switch between two fingers in alternation. This is recommended for recordings greater than 1 hour in duration.

Measurement accuracy

Human NIBP Controller enables the measurement of continuous arterial blood pressure in the finger. It is important to realize that the finger arterial blood pressure may differ from the blood pressure measured in the brachial artery or aorta. There may be differences in waveform and in absolute level. As a consequence, interpretation of finger blood pressure measurements with the Human NIBP Controller, in particular when the outcome of such measurements is used as an adjunct in a patient's diagnosis, should be performed with care.

Comparison with intra-arterial blood pressure

Since blood pressure readings depend on the site of measurement, a comparison of finger arterial blood pressure and intra-arterial pressure is also affected by the choice of intra-arterial pressure site. We will focus on the finger and brachial intra-arterial measurement sites.

Finger arterial pressure

Although it is not possible to measure intra-arterial pressure in a finger artery, there is evidence that Human NIBP Controller indeed measures finger arterial blood pressure.

In simultaneous recordings with two finger blood pressure monitoring devices it could be determined that the unloaded diameter determined using the PhysioCal algorithm was close to the theoretically required $1/4-1/2$ of the open diameter level [Wesseling 1995]. At this diameter the transmural pressure is close to zero, and therefore finger cuff pressure is equal to intra-arterial finger blood pressure.

A second basis for the assumption that Human NIBP Controller correctly measures finger arterial blood pressure is a phenomenon that usually can be observed in a pressure tracing at the start of a Human NIBP measurement.

During start-up a pressure staircase is performed to monitor finger plethysmographic values at different pressure levels. The pressure staircase is continued until the arterial diameter changes detected by the plethysmogram virtually disappear, provided cuff pressure is above 100 mmHg. Therefore, at the last pressure level in a pressure staircase, finger cuff pressure is just above systolic pressure. When the continuous finger blood pressure measurement is started immediately after the pressure staircase, and when blood pressure is sufficiently stable, the systolic pressure usually matches the cuff pressure during the last step in the pressure staircase.

Figure A-10
Relationship between
finger arterial systolic
pressure and start-up
staircase procedure.

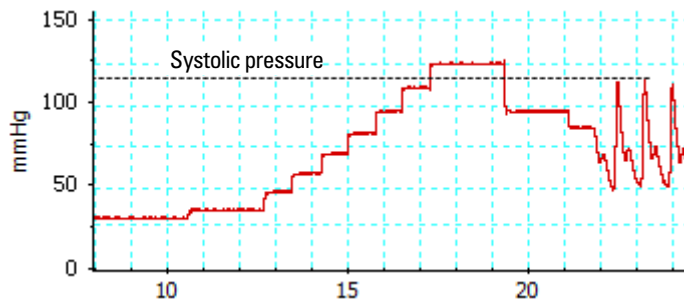

If, however, the arterial blood pressure is not stable, or in case of arrhythmias, movement artifacts, or contracted arteries, the Human NIBP Controller may need to explore the pressure-diameter relationship of the finger artery at higher pressure levels during the staircase procedure. Therefore, the similarity of the pressure during the last step of the staircase and the finger arterial systolic pressure, as shown in Figure A-10, is not always present.

Brachial arterial pressure

If simultaneous tracings of finger arterial pressure and brachial pressure are available, the pressure tracings usually look very similar, apart from a (small) level shift and sometimes some pulse amplification (see Figure A-11 and Figure A-12).

Pulse wave distortion

Pressure pulsations are progressively distorted on their way towards the periphery. The shape of the pressure wave is changed both by reflection and by a pressure gradient due to branching of the arterial tree. Peripheral reflection results in a frequency-dependent amplification of the pressure wave; this leads to increased systolic pressure in a heart rate-dependent manner [Bos 1995]. Hence, finger blood pressure waveforms are more undulatory than brachial arterial pressure waveforms because of reflections of the systolic pulse wave in the arterial system of the arm. However, when finger pressure is compared to the intra-radial pressure this distortion is less pronounced [Settels 1985].

The next two figures (Figure A-11 and Figure A-12) provide two examples of simultaneous recordings of brachial and non-invasive finger arterial pressure in an elderly woman and a young man. Note the small delay between the brachial pressure wave and the finger pressure wave is due to time needed for the pulse wave to travel along the arm artery.

Figure A-11
Finger and brachial artery pressure waveforms in a woman aged 73. [Data from a study in elderly healthy volunteers by Rongen et al., 1995.]

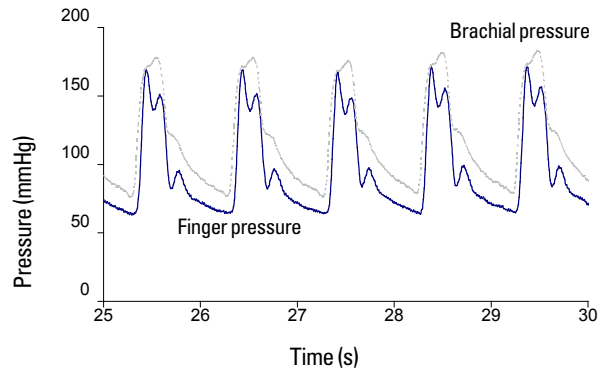
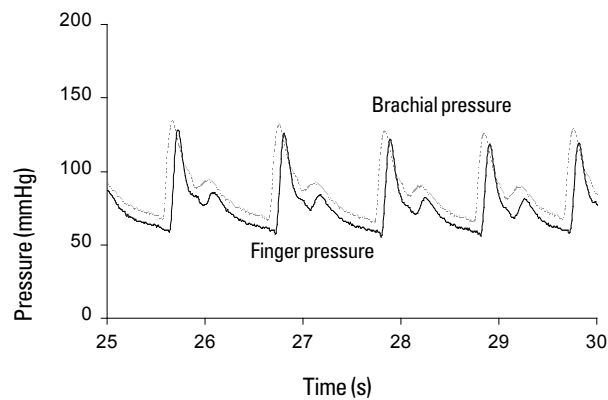

Figure A-12
Finger and brachial artery pressure waveforms in a man aged 27. [Data from study of Harms et al, 1999.]



Pressure gradient

Mean finger blood pressure is lower than mean intra-arterial brachial pressure due to a pressure gradient over the arm arteries caused by flow. This pressure decay was found to increase with age, whereas pulse wave amplification is highest in the young. Due to the combined effects of pulse wave amplification and pressure decay, systolic pressure is elevated in the young but equal to or even lower than brachial pressure in elderly subjects. The mean pressure gradient is clearly present in Figure A-11 and Figure A-12.

Bias and precision

In a group of 53 subjects, described in previous studies [Bos 1992, Idema 1987, Rongen 1995] the following data were obtained for brachial and finger pressure:

Table A-1: Pressures and pressure differences, (53 subjects, aged 22–83 years, all numbers in mmHg, mean±SD).

	Brachial	Finger	Finger-Brachial
Systolic	169 ± 33	163 ± 29	-5 ± 15
Diastolic	89 ± 17	81 ± 18	-9 ± 10
Mean	118 ± 22	104 ± 21	-13 ± 11

These numbers tend to vary somewhat per study, presumably because of age differences of the subjects in the studies. Thus, averaged over a study population, finger arterial mean pressure is about 10 mmHg lower than intra-arterial pressure in the brachial artery, but individual differences may be larger.

Although the Human NIBP Controller does not meet all requirements for non-invasive blood pressure monitoring (for example, according to the Association of Medical Instrumentation (AAMI)), the tracking accuracy of the Human NIBP Controller is considered sufficiently good to study blood pressure changes, for example, in the study of orthostatic hypotension or cardiovascular maneuvers such as Valsalva straining [Imholz 1998].

Clinical use

Due to the non-brachial pressure site, the Human NIBP Controller should not be used as a replacement for the upper arm cuff blood pressure measurement devices that are normally used in a clinical setting. However, the Human NIBP Controller is ideal for ambulatory long-term measurements, for example, in the study of the circadian 24-hour blood pressure profile and in conditions where fast hemodynamic changes are expected, such as during cardiovascular stress testing, orthostatic tolerance testing, and in many other physiological studies. See “Clinical Experience” on page 65 for a list of references.

In general, all these studies prefer a finger blood pressure measurement device over a more conventional blood pressure measurement device for one or more of the following reasons:

- Non invasive measurement.
- Continuous beat-to-beat blood pressure and heart rate data available.
- Possibility to perform a comprehensive hemodynamic analysis on the full pressure waveform using, for example, the Heart Rate Variability (HRV) module available with the LabChart Pro® software package (see www.adinstruments.com).
- Ambulatory measurements and high-fidelity data storage to a computer hard drive.

Waveform filtering and level correction methods

Two Finometer devices available from Finapres Medical Systems B.V. (FMS), the Finometer Model-1 (PRO) and Finometer Model-2 (MIDI), have additional features compared to the Human NIBP Controller:

- The reconstruction of continuous brachial artery blood pressure, based on non-invasive finger arterial pressure measurement, is implemented based on published pressure waveform reconstruction and calibration methods (see below). Finometer PRO has an additional upper arm cuff circuitry to perform a so-called Return-to-Flow (RTF) calibration of the brachial waveform by measuring the Systolic pressure in an individual subject. Thus, the Finometer PRO complies with the AAMI/SP-10 standard for blood pressure measurement devices. The Finometer MIDI does not have the RTF calibration circuitry. Still, the accuracy and precision of the Finometer MIDI are significantly improved as compared to the original Finapres devices.
- Cardiac output, based on the patented Modelflow method developed by FMS, and other hemodynamic data are available in real time on a built-in color display. Cardiac output, the amount of blood the heart pumps per minute, is the product of heart rate and stroke volume (the volume of blood pumped out of the left ventricle with each beat). For a description of the three-element model of arterial input impedance (Modelflow), which is used to compute the stroke volume of the heart from the arterial pressure wave, see Harms et al., 1999.

If desired, similar calculations can be performed in LabChart using LabChart's Channel calculations and Arithmetic functions. See the LabChart Help for further information. The LabChart Pro Cardiac Output module permits the user to calculate cardiac output from a recorded thermodilution curve, which is a well-established technique.

Reconstructing intra-arterial brachial pressure

The distortion of the pressure waveform along an artery can be investigated with special mathematical techniques such as Fourier spectra. These analyses showed that the distortion of finger arterial pressure is caused by a resonance, a tendency of the arm arterial system to oscillate, at about 8 Hz. The amplification of pulse pressure that is a consequence of this resonance is attributed to a gradual decrease in arterial diameter, to an increase arterial stiffness of the distal arterial tree and to wave reflections.

A method has been described to derive brachial pressure waveforms from finger arterial pressure by means of waveform filtering [Gizdulich 1996]. Additionally, a method was developed to correct for the pressure gradient using a regression equation. Both methods are addressed in the following sections.

Wave distortion correction

Figure A-13 shows the transfer function from brachial to finger pressure with a maximum at about 8 Hz. The transfer function was calculated by comparing simultaneous brachial and finger pressure waveforms in a group of patients [Gizdulich 1996]. The resonance peak at 8 Hz causes oscillatory distortions in the finger pressure waveform. Using Fourier techniques Gizdulich et al. succeeded in deriving a digital function that can be used to filter a finger pressure waveform back to a brachial pressure waveform.

Figure A-13
Transfer function from brachial artery to finger, with a maximum near 8 Hz. The second curve with an anti-resonant dip at 8 Hz is the waveform filter of Gizdulich et al. [Gizdulich 1996]

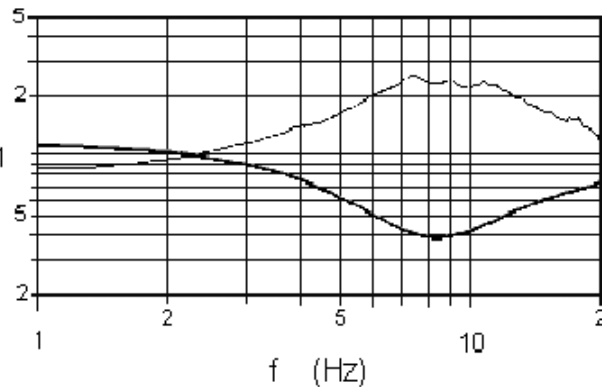

After this waveform filtering the mean pressure level is not yet equal to brachial mean blood pressure level. The correction method to get a mean pressure level that is, on average, correct, is described next.

Pressure gradient correction

Using the waveform distortion correction method described above, a pressure level correction was developed that makes use of a multiple regression model of the blood pressure differences between brachial artery and finger artery as dependent variable upon diastolic and pulse pressure after wave distortion correction [Gizdulich 1997]:

Combination of waveform filtering, level correction and RTF calibration

When both waveform filtering and level correction are applied the results shown in Table A-2 were found in a study in 37 subjects, aged 41–83 years, after a cardiac catheterization procedure. Finger arterial pressures were compared after application of waveform filtering and level correction (flcAP), and after an additional RTF calibration using a standard upper arm cuff (reBAP).

Reconstruction of brachial intra-arterial pressure from FinAP is implemented in the Finometer® model-1 (PRO). Together with an individual RTF calibration, this was found to reduce the pressure differences to within AAMI/SP10 requirements.

As an illustration of this, see published data from the study of Guelen et al., 2003 in Table A-2 below. Differences between the measured intra-brachial arterial pressure and the finger arterial pressure, uncorrected (FinAP) and corrected (reBAP) are shown.

Table A-2: Comparison with brachial artery pressure. Mean (accuracy) and standard deviation (SD) of the differences between the original finger arterial pressure (FinAP), the waveform-filtered and level-corrected pressure (ficAP), and the return-to-flow calibrated waveform-filtered and level-corrected pressure (reBAP), all compared to the measured intra-brachial pressure [Guelen et al., 2003].

	Systolic	(mmHg)	Diastolic	(mmHg)	Mean	(mmHg)
	Mean	SD	Mean	SD	Mean	SD
FinAP	-9.7*	13.0	-11.6*	8.0	-16.3*	7.9
ficAP	-1.1	10.7	- 0.2	6.8	- 1.5	6.6
reBAP	3.1*	7.6+	4.0*	5.6+	2.7*	4.7+

*P<0.05 using paired Student's t-test, +P<0.05 using F-test for variance ratios.

Finger arterial pressure methods

Bos WJW, van den Meiracker AH, Wesseling KH, Schalekamp MADH. Effect of regional and systemic changes in vasomotor tone on finger pressure amplification. *Hypertension* 1995; 26: 315-320.

Bos WJW, van Goudoever J, van Montfrans GA, van den Meiracker AH, Wesseling KH. Reconstruction of brachial artery pressure from noninvasive finger pressure measurements. *Circulation* 1996; 94: 1870-1875.

Castiglioni P, Parati G, Omboni S, Mancina G, Imholz BPM, Wesseling KH, Pedotti A, DiRienzo M. Broadband. Spectral analysis of 24-h continuous finger blood pressure: comparison with intra-arterial recordings. *Clin Science* 1999; 97: 129-139.

DeJong-de Vos van Steenwijk CCE, Wieling W, Johannes MD, Harms MP, Kuis W, Wesseling KH. Incidence and hemodynamic characteristics of near-fainting in healthy 6 to 16 year old subjects. *JACC* 1995; 25: 1615-1621.

Gordy E, Drabkin DL. Spectrophotometric studies. XVI. Determination of the oxygen saturation of blood by a simplified technique, applicable to standard equipment. *J Biol Chem.* 1957 Jul; 227(1): 285-299.

Gravenstein JS, Paulus DA, Feldman J, McLaughlin G. Tissue hypoxia distal to a Peñáz finger blood pressure cuff. *J Clin Monit* 1985; 1: 120-125.

Gizdulich P, Imholz BPM, van den Meiracker AH, Parati G, Wesseling KH. Finapres tracking of systolic pressure and baroreflex sensitivity improved by waveform filtering. *J Hypertens* 1996; 14: 243-250.

Gizdulich P, Prentza A, Wesseling KH. Models of brachial to finger pulse wave distortion and pressure decrement. *Cardiovasc Res* 1997; 33: 698-705.

Guelen I, Westerhof BE, van der Sar GL, van Montfrans GA, Kiemeneij F, Wesseling KH, Bos WJW. Finometer, finger pressure measurements with the

possibility to reconstruct brachial pressure. *Blood Pressure Monitoring* 2003; 8: 27-30.

Harms MPM, Wesseling KH, Pott F, Jenstrup M, van Goudoever J, Secher NH, Lieshout JJ. Continuous stroke volume monitoring by modelling flow from non-invasive measurement of arterial pressure in humans under orthostatic stress. *Clinical Science* 1999; 97: 291-301.

Imholz BPM, Wieling W, Langewouters GJ, van Montfrans GA. Continuous finger arterial pressure; utility in the cardiovascular laboratory. *Clin Auton Res* 1991; 1: 43-53.

Imholz BPM, Langewouters GJ, van Montfrans GA, Parati G, van Goudoever J, Wesseling KH, Wieling W, Mancia G. Feasibility of ambulatory, continuous 24-hour finger arterial pressure recording. *Hypertension* 1993; 21: 65-73.

Imholz BPM, Wieling W, van Montfrans GA, Wesseling KH. Fifteen years experience with finger arterial pressure monitoring: assessment of the technology. *Cardiovasc Res* 1998; 38: 605-616.

Jansen JRC, Schreuder JJ, Mulier JP, Smith NT, Settels JJ, Wesseling KH. A comparison of Modelflow cardiac output derived from the arterial pressure wave against thermodilution in cardiac surgery patients. *Br J Anaesth* 2001; 87: 212-222.

Langewouters GJ, Wesseling KH, Goedhard WJA. The static elastic properties of 45 human thoracic and 20 abdominal aortas in vivo and the parameters of a new model. *J Biomech* 1984; 17: 425-435.

Murray A, Marjanovic D. Optical assessment of recovery of tissue blood supply after removal of externally applied pressure. *Medical & Biological Engineering & Computing* 1997; 35(4): 425-427.

Peñáz J. Photoelectric measurement of blood pressure, volume and flow in the finger. *Digest 10th Int Conf Med Biol Engng, Dresden* 1973; p 104 (abstract).

Smith NT, Wesseling KH, de Wit B. Evaluation of two prototype devices producing noninvasive, pulsatile, calibrated blood pressure measurement from a finger. *J Clin Monit* 1985; 1: 17-29.

Wesseling KH, Jansen JRC, Settels JJ, Schreuder JJ. Computation of aortic flow from pressure in humans using a nonlinear, three-element model. *J Appl Physiol* 1993; 74: 2566-2573.

Wesseling KH, de Wit B, van der Hoeven GMA, van Goudoever J, Settels JJ. Physiocal, calibrating finger vascular physiology for Finapres. *Homeostasis* 1995; 36: 67-82.

Clinical Experience

Bardoczky GI, Levarlet M, Engelman E, d'Hollander A, Schmartz D. Continuous noninvasive blood pressure monitoring during thoracic surgery. *Journal of Cardiothoracic & Vascular Anesthesia* 1992; 6(1): 51-4.

Bos WJ, Imholz BP, van Goudoever J, Wesseling KH, van Montfrans GA. The reliability of noninvasive continuous finger blood pressure measurement in patients with both hypertension and vascular disease. *American Journal of Hypertension* 1992; 5(8): 529-535.

Bos WJ, van den Meiracker AH, Wesseling KH, Schalekamp MA. Effect of regional and systemic changes in vasomotor tone on finger pressure amplification. *Hypertension* 1995; 26(2): 315-320.

Blum V, Carriere EG, Kolsters W, Mosterd WL, Schiereck P, Wesseling KH. Aortic and peripheral blood pressure during isometric and dynamic exercise. *International Journal of Sports Medicine* 1997; 18(1): 30-34.

Castiglioni P, Parati G, Omboni S, Mancina G, Imholz BP, Wesseling KH, Di Rienzo M. Broad-band spectral analysis of 24 h continuous finger blood pressure: comparison with intra-arterial recordings. *Clinical Science* 1999; 97(2): 129-139.

Dorlas JC, Nijboer JA, Butijn WT, van der Hoeven GM, Settels JJ, Wesseling KH. Effects of peripheral vasoconstriction on the blood pressure in the finger, measured continuously by a new noninvasive method (the Finapres). *Anesthesiology* 1985; 62(3): 342-345.

Drouin E, Gournay V, Calamel J, Mouzard A, Roze JC. Feasibility of using finger arterial pressure in neonates. *Archives of Disease in Childhood Fetal & Neonatal Edition* 1997; 77(2): F139-140.

Epstein RH, Bartkowski RR, Huffnagle S. Continuous noninvasive finger blood pressure during controlled hypotension, A comparison with intraarterial pressure. *Anesthesiology* 1991; 75(5): 796-803.

Gravenstein JS, Paulus DA, Feldman J, McLaughlin G. Tissue hypoxia distal to a Peñáz finger blood pressure cuff. *Journal of Clinical Monitoring* 1985; 1: 120-125.

Hirschl MM, Binder M, Herkner H, Bur A, Brunner M, Seidler D, Stuhlinger HG, Laggner AN. Accuracy and reliability of noninvasive continuous finger blood pressure measurement in critically ill patients. *Critical Care Medicine*, 1996; 24(10): 1684-1689.

Idema RN, van den Meiracker AH, Imholz BP, Man in 't Veld AJ, Settels JJ, Ritsema van Eck HJ, Schalekamp MA. Comparison of Finapres non-invasive beat-to-beat finger blood pressure with intrabrachial artery pressure during

and after bicycle ergometry. *Journal of Hypertension – Supplement* 1989; 7(6): S58-599.

Imholz BP, van Montfrans GA, Settels JJ, van der Hoeven GM, Karemaker JM, Wieling W. Continuous non-invasive blood pressure monitoring: reliability of Finapres device during the Valsalva manoeuvre. *Cardiovascular Research* 1988; 22(6): 390-397.

Imholz BP, Wieling W, Langewouters GJ, van Montfrans GA. Continuous finger arterial pressure: utility in the cardiovascular laboratory. *Clinical Autonomic Research* 1991; 1(1): 43-53.

Imholz BP, Parati G, Mancia G, Wesseling KH. Effects of graded vasoconstriction upon the measurement of finger arterial pressure. *Journal of Hypertension* 1992; 10(9): 979-984.

Imholz BP. Automated blood pressure measurement during ergometric stress testing: possibilities of Finapres. *Zeitschrift für Kardiologie* 1996; 85 Suppl 3: 76-80.

Jagomagi K, Talts J, Raamat R, Lansimies E. Continuous noninvasive measurement of mean blood pressure in fingers by volume-clamp and differential oscillometric method. *Clinical Physiology* 1996; 16(5): 551-560.

Jellema WT, Imholz BP, van Goudoever J, Wesseling KH, van Lieshout JJ. Finger arterial versus intrabrachial pressure and continuous cardiac output during head-up tilt testing in healthy subjects. *Clinical Science* 1996; 91(2): 193-200.

de Jong-de Vos van Steenwijk CC, Wieling W, Harms MP, Wesseling KH. Variability of near-fainting responses in healthy 6-16-year-old subjects. *Clinical Science* 1997; 93(3): 205-211.

Lindqvist A. Beat-to-beat agreement of non-invasive finger artery and invasive radial artery blood pressure in hypertensive patients taking cardiovascular medication. *Clinical Physiology* 1995; 15(3): 219-229.

Marey EJ. *La méthode graphique dans les sciences expérimentales et principalement en physiologie et en médecine*. Masson 1878, Paris.

Nijboer JA, Dorlas JC, Lubbers J. The difference in blood pressure between upper arm and finger during physical exercise. *Clinical Physiology* 1988; 8(5): 501-510.

Omboni S, Smit AA, Wieling W. Twenty four hour continuous noninvasive finger blood pressure monitoring: a novel approach to the evaluation of treatment in patients with autonomic failure. *British Heart Journal* 1995; 73(3): 290-292.

Omboni S, Parati G, Castiglioni P, Di Rienzo M, Imholz BP, Langewouters GJ, Wesseling KH, Mancia G. Estimation of blood pressure variability from 24-hour ambulatory finger blood pressure. *Hypertension* 1998; 32(1): 52-58.

Parati G, Casadei R, Groppelli A, Di Rienzo M, Mancia G. Comparison of finger and intra-arterial blood pressure monitoring at rest and during laboratory testing. *Hypertension* 1989; 13(6 Pt 1): 647-655.

Penzel T, Mayer J, Peter JH, Podszus T, Voigt KH, von Wichert P. Continuous non-invasive blood pressure monitoring in patients with sleep disorders. *Physiological Research* 1992; 41(1): 11-17.

Peterson ME, Williams TR, Sutton R. A comparison of non-invasive continuous finger blood pressure measurement (Finapres) with intra-arterial pressure during prolonged head-up tilt. *European Heart Journal* 1995; 16(11): 1641-1654.

Porter KB, O'Brien WF, Kiefert V, Knuppel RA. Finapres: a noninvasive device to monitor blood pressure. *Obstetrics & Gynecology* 1991; 78(3 Pt 1): 430-433.

Rongen GA, Bos WJ, Lenders JW, van Montfrans GA, van Lier HJ, van Goudoever J, Wesseling KH, Thien T. Comparison of intrabrachial and finger blood pressure in healthy elderly volunteers. *American Journal of Hypertension* 1995; 8(3): 237-248.

Schmidt TF, Wittenhaus J, Steinmetz TF, Piccolo P, Lupsen H. Twenty-four-hour ambulatory noninvasive continuous finger blood pressure measurement with PORTAPRES: a new tool in cardiovascular research. *Journal of Cardiovascular Pharmacology* 1992; 19 Suppl 6: S117-145.

Tanaka H, Thulesius O, Yamaguchi H, Mino M. Circulatory responses in children with unexplained syncope evaluated by continuous noninvasive finger blood pressure monitoring. *Acta Paediatrica* 1994; 83(7): 754-761.

Tanaka H, Thulesius O, Yamaguchi H, Mino M, Konishi K. Continuous non-invasive finger blood pressure monitoring in children. *Acta Paediatrica* 1994; 83(6): 646-652.

Veerman DP, Imholz BP, Wieling W, Karemaker JM, van Montfrans GA. Effects of aging on blood pressure variability in resting conditions. *Hypertension* 1994; 24(1): 120-130.

Voogel AJ, Bos WJW, van Goudoever J, van Montfrans GA, Wesseling KH. Finger-to-brachial comparability of 'Modelflow' stroke volume improves after pulsewave reconstruction. *Clinical Physiology* 1997; 17: 327-337.

Voogel AJ, Stok WJ, Pretorius PJ, Van Montfrans GA, Langewouters GJ, Karemaker JM. Circadian blood pressure and systemic hemodynamics

during 42 days of 6 degrees head-down tilt. *Acta Physiologica Scandinavica* 1997; 161(1): 71-80.

Voogel AJ, van Montfrans GA. Reproducibility of twenty-four-hour finger arterial blood pressure, variability and systemic hemodynamics. *Journal of Hypertension* 1997; 15: 1761-1765.

Voogel AJ, van Steenwijk RP, Karemaker JM, van Montfrans GA. Effects of treatment of obstructive sleep apnea on circadian hemodynamics. *Journal of the Autonomic Nervous System* 1999; 77: 177-183.

Note : See the FMS website (www.finapres.com) for additional references.

C

Specifications

Physical Configuration

Wrist Unit

Material:	Aluminium with Velcro® fastening
Dimensions:	65 × 50 × 30 mm
Weight:	160 grams (Wrist Unit cable excluded); 580 grams (Wrist Unit cable included)

Human NIBP Controller

Dimensions (h × w × d):	58 × 191 × 249 mm (2.3" × 7.5" × 9.8")
Weight:	2600 grams
Power Requirements:	100 to 240 VAC, 47 to 65 Hz, 30W
Sample Rate:	200 Hz maximum

Environmental Specifications

Operating Temperature:	10–40 °C (50–104 °F)
Storage Temperature:	-20–70 °C (-4–158 °F)
Humidity:	5–90% humidity (non condensing)
Ambient pressure:	700 to 1100 hPa

The device may not meet its performance specifications if stored or used outside the ranges specified above.

Instrumental Information

Cuff pressure:	Max. 300 mmHg
Height sensing:	Range \pm 128 mmHg
Blood pressure accuracy:	1% of full scale (max. 3 mmHg) Zeroing automatic
Finger cuff pump system:	Pressure regulated at 380 mmHg; Max. pressure: 420 mmHg
Analog output connector:	BNC-type

Analog Output signals

Update frequency:	200 Hz
Time delay:	< 5 ms
Offset:	0
Scaling:	100 mmHg/V

Analog Output connection

Analog output range:	0 to 4.0 V
Resolution:	2.5 mV
Offset:	\pm 5 mV
Internal impedance:	< 1 Ω

Instrumental accuracy

Finger cuff pressure:	1% of full scale (max. 3 mmHg) Automatic zeroing, typically, 0.5 mmHg
Height correction:	2% of full scale (max. 3 mmHg) Manual zeroing
Heart rate:	(Rate (bpm) /60%), i.e., at 60 bpm, accuracy is \pm 1%
Interbeat interval:	5ms (peak, non-accumulating)

Electrical Specifications

Power requirements:	100 – 240 VAC, 50/60 Hz, 50 VA
Main unit fuse:	IEC 127, 0.8 A slow blow
Power cord:	IEC 320 to local mains plug
Protection against electric shock (EN 60601-1):	Type of protection: Class I equipment Degree of protection: type B, applied part
Power dissipation:	In Human NIBP Controller: < 50 W In Wrist Unit: 1 W In finger cuff: < 50 mW

The EMC conformity of the Human NIBP Controller includes the use of the following external cables, transducers and accessories:

Cable/accessory	Description
Power cord	Country specific type *
Wrist Unit cable assembly, including Height Correction Unit and finger cuff connected to the Wrist Unit	Standard length Wrist Unit cable assembly: 275 cm. Standard length HCU cable: 30 cm.
* See table below for country-specific power cord details.	

The non-observance may result in increased emissions or decreased immunity of the Human NIBP Controller.

The following power supply cords can be used for the countries specified in the table:

Component	Trademark	Type/ Model. No	Technical Data	Standard No.	Mark(s) & Certificates of conformity
Cord set (Europe)	Eulectic	Plug: 10-16 A, 250V	2 pole, class I	IEC60320	KEMA KEUR, VDE,
		Cord: H0VV-F	3 x 0.75 mm ²	HD21	KEMA KEUR,
		Appliance coupler: 10 A, 250 V	2 pole, class I		KEMA KEUR VDE

Cord set (Europe)	Several	Plug: 10-16 A, 250 V Cord: H0VV-F Appliance coupler: 10 A, 250 V	2 pole, class I 3 x 0.75 mm ² 2 pole, class I	IEC60320 HD21 IEC 60320	KEMA KEUR, VDE, HAR or KEMA KEUR, KEMA KEUR VDE
Cord set (UK)	Well Shin	Plug: 10 A, 250 V Cord: 3 x min 0.75 mm ² Appliance coupler: 10 A, 250 V	2 pole, class I 3 x AWG 18 H05VV-F	IEC60320 C13	ASTA
Cord set (USA, CAN)	Ta Hsing	Plug: NEMA 5-15 15 A, 125 Cord: SJTW, hospital grade Appliance coupler: C13: 10 A, 250 V	2 pole, class I 3 x 18 AWG 2 pole, Class I	UL 498 CSA 21 IEC	UL, CSA

Electromagnetic Compatibility

The Human NIBP Controller has been tested to comply with the requirements of EN60601-1-2 + A1: medical electrical equipment; EMC requirements and tests. The device also conforms to the following safety standards: CORR.2 (2007) and Canadian/US differences according to CAN/CSA-C22.2 No. 60601-1:08, and ANSI/AAMI ES60601-1:2005.

Emissions

- The Human NIBP Controller uses RF energy for its internal function only. RF emissions are very low and are not likely to cause any interference in nearby electronic equipment.
- The Human NIBP Controller is suitable for use in all establishments, including domestic establishments and those directly connected to the public low-voltage power supply network that supplies buildings used for domestic purposes.

- The Human NIBP Controller should not be used adjacent to or stacked with other equipment and that if adjacent or stacked use is necessary, the Human NIBP Controller should be observed to verify normal operation in the configuration in which it will be used.

The Human NIBP Controller is intended for use in the electromagnetic environment specified below. The customer or the user of the Human NIBP Controller should assure that it is used in such an environment.		
Emmissions test	Compliance	Electromagnetic environment – guidance
RF emissions CISPR 11	Group 1	The Human NIBP Controller uses RF energy only for its internal function. Therefore, its RF emissions are very low and are not likely to cause any interference in nearby electronic equipment.
RF emissions CISPR 11	Class A	The Human NIBP Controller is suitable for use in all establishments, including domestic establishments and those directly connected to the public low-voltage power supply network that supplies buildings used for domestic purposes.
Harmonic emissions IEC 61000-3-2	Class A	
Voltage fluctuations/ flicker emissions IEC 61000-3-3	Complies	

Immunity

- Mains power quality should be that of a typical commercial or hospital environment. If the user of the devices requires continued operation during power mains interruptions, it is recommended that the devices be powered from an uninterruptible power supply or a battery.
- Power frequency magnetic fields should be at levels characteristic of a typical location in a typical commercial or hospital environment.
- Floors should be wood, concrete or ceramic tile. If floors are covered with synthetic material, the relative humidity should be at least 30%.

Electromagnetic Immunity – Guidance and manufacturer’s declaration			
The Human NIBP Controller is intended for use in the electromagnetic environment specified below. The customer or the user of the Human NIBP Controller should assure that it is used in such an environment.			
Immunity Test	IEC 60601 test level	Compliance level	Electromagnetic environment – guidance
Electrostatic discharge(ESD) IEC 61000-4-2	±6 kV contact ±8 kV air	6 kV contact ±8 kV air	Floors should be wood, concrete or ceramic tile. If floors are covered with synthetic material, the relative humidity should be at least 30%
Electrical fast transient/burst IEC 61000-4-4	±2 kV for power supply lines ±1 kV for input/output lines	±2 kV for power supply lines ±1 kV for input/output lines	Mains power quality should be that of a typical commercial or hospital environment.
Surge IEC 61000-4-5	±1 kV differential mode ±2 kV common mode	±1 kV differential mode ±2 kV common mode	Mains power quality should be that of a typical commercial or hospital environment.
Voltage dips, short interruptions and voltage variations on power supply input lines IEC 61000-4-11	< 5% U_t (>95% dip in U_t for 0.5 cycle) 40% U_t (60% dip in U_t) for 5 cycles 70% U_t (30% dip in U_t for 25 cycles <5% U_t (>95% dip in U_t) for 5 sec	< 5% U_t (>95% dip in U_t for 0.5 cycle) 40% U_t (60% dip in U_t) for 5 cycles 70% U_t (30% dip in U_t for 25 cycles <5% U_t (>95% dip in U_t) for 5 sec	Mains power quality should be that of a typical commercial or hospital environment. If the user of the Human NIBP Controller requires continued operation during power mains interruptions, it is recommended that the Human NIBP Controller be powered from an uninterruptible power supply or a battery.
Note: U_t is the a.c. mains voltage prior to application of the test level.			
Power frequency (50/60 Hz) magnetic field	3 A/m	3 A/m	Power frequency magnetic fields should be at levels characteristic of a typical location in a typical commercial or hospital environment.

<p>Conducted RF IEC 61000-4-6</p> <p>Radiated RF IEC 61000-4-3</p>	<p>3 Vrms 150 kHz to 80 MHz</p> <p>3 V/m 80 MHz to 2.5 GHz</p>	<p>3 V</p> <p>3 V/m</p>	<p>Portable and mobile RF communications equipment should be used no closer to any part of the Human NIBP Controller, including cables, than the recommended separation distance calculated from the equation applicable to the frequency of the transmitter.</p> <p>Recommended separation distance: $d = 1.2\sqrt{P}$</p> <p>$d = 1.2\sqrt{P}$ (80 MHz to 800MHz)</p> <p>$d = 2.3\sqrt{P}$ (800 MHz to 2.5 GHz)</p> <p>where P is the maximum output power rating of the transmitter in watts (W) according to the transmitter manufacturer and d is the recommended separations distance in metres(m).</p> <p>Field strengths from fixed RF transmitters, as determined by an electromagnetic site survey, should be less than the compliance level in each frequency range.</p> <p>Interference may occur in the vicinity of equipment marked with the following symbol:</p>
<p>NOTE 1: At 80 MHz and 800 MHz, the higher frequency range applies. NOTE 2: These guidelines may not apply in all situation. Electromagnetic propagation is affected by absorption and reflection from structures, objects and people.</p>			
<p>^a Field strengths from fixed transmitters, such as base station for radio (cellular/cordless) telephones and land mobile radios, amateur radio, AM and FM radio broadcast and TV broadcast cannot be predicted theoretically with accuracy. To assess the electromagnetic environment due to fixed RF transmitters, an electromagnetic site survey should be considered. If the measured field strength in the location in which the Human NIBP Controller is used exceeds the applicable RF compliance level above. The Human NIBP Controller should be observed to verify normal operation. If abnormal performance is observed, additional measures may be necessary, such as reorienting or relocating the Human NIBP Controller.</p>			
<p>^{aa} Over the frequency range 150 kHz to 80 MHz, field strengths should be less than 3 V/m.</p>			

Separation Distances

- The devices are intended for use in an electromagnetic environment in which radiated RF disturbances are controlled.
- Portable and mobile RF communications equipment should be used no closer to any part of the devices, including cables, than the recommended separation distance in the table below.
- Field strengths from fixed RF transmitters, as determined by an electromagnetic site survey, should be less than the compliance level in each frequency range.

Recommended separation distances between portable and mobile RF communications and the Human NIBP Controller

The Human NIBP Controller is intended for use in an electromagnetic environment in which radiated RF disturbances are controlled. The customer or the user of the Human NIBP Controller can help prevent electromagnetic interference by maintaining a minimum distance between portable and mobile RF communications equipment (transmitters) and the Human NIBP Controller as recommended below, according to the maximum output power of the communications equipment.

Rated maximum output power of transmitter (W)	Separation distance according to frequency of transmitter (m)		
	150 kHz to 80 MHz	80 MHz to 800 MHz	800 MHz to 2.5 GHz
	$d = 1.17\sqrt{P}$	$d = 1.17\sqrt{P}$	$d = 2.33\sqrt{P}$
0.01 W	0.1 m	0.1 m	0.2 m
0.1 W	0.4 m	0.4 m	0.7 m
1 W	1.2 m	1.2 m	2.3 m
10 W	3.7 m	3.7 m	7.3 m
100 W	11.7 m	11.7 m	23.4 m

For transmitters rated at a maximum output power not listed above, the recommended separation distance d in metres (m) can be estimated using the equation applicable to the frequency of the transmitter, where P is the maximum output power rating of the transmitter in Watts (W) according to the transmitter manufacturer.

NOTE 1: At 80 MHz and 800 MHz, the separation distance for the higher frequency range applies

NOTE 2: These guidelines may not apply in all situations. Electromagnetic propagation is affected by absorption and reflection from structures, objects and people.

Finapres Medical Systems B.V. reserves the right to alter these specifications at any time.

Warranty

Product Purchase and License Agreement

This Agreement is between ADInstruments Pty Ltd [‘ADI’] and the purchaser [‘the Purchaser’] of any ADI product or solution — software, hardware or both — and covers all obligations and liabilities on the part of ADI, the Purchaser, and other users of the product. The Purchaser (or any user) accepts the terms of this Agreement by using the product or solution. Any changes to this Agreement must be recorded in writing and have ADI’s and the Purchaser’s consent.

Responsibilities

The Purchaser and any others using any ADI product or solution agree to use it in a sensible manner for purposes for which it is suited, and agree to take responsibility for their actions and the results of their actions. If problems arise with an ADI product, ADI will make all reasonable efforts to rectify them. This service may incur a charge, depending on the nature of the problems, and is subject to the other conditions in this Agreement. ADI does not separately warrant the performance of products, equipment or software manufactured by third parties which may be provided to Purchaser as part of an overall solution. However, as further noted below, ADI will pass through to Purchaser all applicable third party warranties to the extent it has the right to do so.

Statement of Intended Use

Products supplied by ADInstruments are intended for use in teaching and research applications and environments.

Products supplied by ADInstruments are NOT intended to be used as medical devices or in medical environments. That is, no product supplied by ADInstruments is intended to be used to diagnose, treat, or monitor a subject. Furthermore no prod-

uct is intended for the prevention, curing or alleviation of disease, injury or handicap.

Where a product meets IEC 60601-1 it is under the principle that:

1. it is a more rigorous standard than other standards that could be adopted;
2. it provides the most appropriate safety level for subjects and operators.

The choice to meet IEC 60601-1 is in no way to be interpreted to mean that a product:

1. is a medical device;
2. may be interpreted as a medical device;
3. is safe to be used as a medical device

ADI Product Hardware Warranty

ADI warrants that PowerLab Data Acquisition Units (PL prefix)¹ and Front-ends (FE prefix)² shall be free from defects in materials and workmanship for five (5) years from the date of purchase. Other PowerLab Data Acquisition Units³, Front-ends⁴ and Pods⁵ shall be free of defects in material and workmanship for three (3) years from their date of purchase. ADI also warrants that ADI Specialized Data Recorders⁶ and Instruments⁷ shall be free of defects in material and workmanship for one (1) year from their date of purchase. If there is such a defect, as Purchaser's sole remedy hereunder, ADI will repair or replace the equipment as appropriate, and the duration of the warranty shall be extended by the length of time needed for repair or replacement.

To obtain service under this warranty, the Purchaser must notify the nearest ADI office, or Authorized Representative, of the defect before the warranty expires. The ADI or Representative office will advise the Purchaser of the nearest service center address to which the Purchaser must ship the defective product at his or her own expense. The product should be packed safely, preferably in its original packaging. ADI will pay return shipping costs.

Hardware Warranty Limitations

This warranty applies only to the ADI hardware specified in this document and used under normal operating conditions and within specification. Consumables, electrodes and accessories are not covered by this warranty. Third party equipment may be covered by the third party manufacturer's warranty. To the extent that ADI has the right to pass through any third party manufacturer warranties to Purchaser it will do so to the extent it is able to do so. Copies of applicable third party manufacturer warranties, to the extent they exist, are available upon request. The warranty provided hereunder does not cover hardware modified in any way, subjected to unusual physical, electrical or environmental stress, used with incorrectly wired or substandard connectors or cables, or with the original identification marks altered.

Tampering with or breaking of the Warranty Seal will also void the warranty.

Product Types & Warranty Term

ADI manufactured products covered by a five (5) year warranty

¹ Data Acquisition Units: PowerLab 35 series with PL prefix

² Front-ends: ADI Front-end Signal Conditioners with FE prefix.

ADI manufactured products covered by three (3) year warranty

³ Data Acquisition Units: PowerLab 26 series with ML prefix

⁴ Front-ends: ADI Front-end Signal Conditioners with ML prefix.

⁵ Pods: The entire range of ADI Pod Signal Conditioners.

ADI manufactured products covered by one (1) year warranty

⁶ Specialized Data Recorders: Metabolic Systems (e.g., ML240 PowerLab/8M Metabolic System)

⁷ Instruments: Blood FlowMeter, Gas Analyzers, NIBP System (excluding transducers), STH Pump Controller.

Third Party Products (Including Transducers)

Products not manufactured by ADI are covered by the manufacturer's warranty.

Accessories and Consumables

Accessories and Consumables are not covered by any type of warranty.

General Limitations

ADI products are produced to high standards, and should perform as described in the supplied documentation. There is a limited hardware warranty, and technical support is provided for all ADI products. Nevertheless, since ADI products could be affected by external factors (for instance, the computer system on which they run and other hardware and/or software provided by third parties), absolute performance and reliability of products and the overall solution cannot be guaranteed. No warranty, either expressed or implied or statutory, other than that expressly contained in this Agreement, is made in respect to ADI products or software, third party products or software, the overall solution or otherwise. The Purchaser therefore assumes all risks as to the performance and reliability of the products, the software, the solution and the results gained using them. ADI neither assumes or authorizes any person to assume on its behalf any liability in connection with the sale, installation, service or use of its products. ADI shall not be held responsible for special, consequential or punitive damages of any kind arising out of sale, installation service or use of its products.

EXCEPT FOR THE EXPRESS WARRANTY SET FORTH HEREIN, THE SOLUTION AS WELL AS ALL EQUIPMENT AND SOFTWARE PROVIDED HEREUNDER ARE PROVIDED "AS IS" AND ADI MAKES NO WARRANTY

AS TO ITS USE OR PERFORMANCE. EXCEPT FOR ANY WARRANTY, CONDITION, REPRESENTATION OR TERM THE EXTENT TO WHICH CANNOT BE EXCLUDED OR LIMITED BY APPLICABLE LAW, ADI AND ITS SUPPLIERS MAKE NO WARRANTY, CONDITION, REPRESENTATION, OR TERM (EXPRESS OR IMPLIED, WHETHER BY STATUTE, COMMON LAW, CUSTOM, USAGE OR OTHERWISE) AS TO ANY MATTER INCLUDING, WITHOUT LIMITATION, NON INFRINGEMENT OF THIRD PARTY RIGHTS, MERCHANTABILITY, INTEGRATION, OR FITNESS FOR A PARTICULAR PURPOSE. YOU ASSUME RESPONSIBILITY FOR SELECTING THE SOLUTION TO ACHIEVE YOUR INTENDED RESULTS, AND FOR THE INSTALLATION OF, USE OF, AND RESULTS OBTAINED FROM THE EQUIPMENT AND SOFTWARE. WITHOUT LIMITING THE FOREGOING PROVISIONS, ADI MAKES NO WARRANTY THAT THE EQUIPMENT OR SOFTWARE WILL BE ERROR-FREE OR FREE FROM INTERRUPTIONS OR OTHER FAILURES OR THAT THE SOFTWARE OR EQUIPMENT WILL MEET YOUR REQUIREMENTS.

UNDER NO CIRCUMSTANCES AND UNDER NO LEGAL THEORY, WHETHER IN TORT, CONTRACT, OR OTHERWISE, SHALL ADI OR ITS SUPPLIERS BE LIABLE TO PURCHASER OR TO ANY OTHER PERSON FOR LOSS OF PROFITS, LOSS OF GOODWILL, OR ANY INDIRECT, SPECIAL, INCIDENTAL, OR CONSEQUENTIAL DAMAGES, OR DAMAGES FOR GROSS NEGLIGENCE OF ANY CHARACTER INCLUDING, WITHOUT LIMITATION, DAMAGES FOR LOSS OF GOODWILL, WORK STOPPAGE, COMPUTER FAILURE OR MALFUNCTION, OR FOR ANY OTHER DAMAGE OR LOSS. IN NO EVENT SHALL ADI OR ITS SUPPLIERS BE LIABLE FOR ANY DAMAGES IN EXCESS OF THE PRICE PAID FOR THE EQUIPMENT AND SOFTWARE, EVEN IF ADI, OR ITS AUTHORIZED PARTNERS OR SUPPLIERS HAVE BEEN ADVISED OF THE POSSIBILITY OF SUCH DAMAGES.

ADI is acting on behalf of its suppliers for the purpose of disclaiming, excluding and/or limiting obligations, warranties and liability as provided in this agreement, but in no other respects and for no other purpose. The foregoing provisions shall be enforceable to the maximum extent permitted by applicable law.

Controlling Law and Severability

This license shall be governed by the laws of the territory into which the software is sold, or if sold into the United States of America, by the laws of the State of California.

Technical Support

The Purchaser is entitled to free technical support for any ADI product for one year from its date of purchase. Our technical support staff can provide advice concerning installation and operation of ADI products. Services outside of this may incur a charge. Technical support staff will not provide experimental protocols or procedural

instructions for conducting experiments. However, information of this type may be provided in the supplied product documentation, or on ADI web sites.

Inquiries

For additional information or service inquiries please contact the nearest ADInstruments office or Authorized Distributor. For contact details see www.ADIstruments.com

C006E

Software License Agreement

By installing, copying or using Software (defined below), Licensee (defined below) agrees to the license terms set forth below. If Licensee does not agree to the terms of this Agreement, Licensee must uninstall the Software and return to ADInstruments any physical copies of the Software in Licensee's possession.

The "Effective Date" for this agreement shall be the date Licensee installs the Software.

1. Definitions

"ADInstruments" means ADInstruments Pty Ltd, 13/22 Lexington Drive, Bella Vista, Australia.

"Computer" means any multi-purpose computing device, including, without limitation, a desktop computer, a laptop computer, a network server, or a smartphone.

"Licensee" means the purchaser of a license or licenses to the Software, as designated in the invoice(s) pertaining to the Software license(s).

"Software" means:

- a. the ADInstruments products identified in this Agreement ("ADInstruments Products");
- b. documentation;
- c. any media, printed materials, documents, electronic files (including, without limitation, settings and example data files), illustrations, explanations, or other information that accompanies or is a component of the ADInstruments Products; and
- d. any modifications, upgrades, updates, and/or additions to Software (collectively, "Upgrades") that are not licensed under a separate agreement.

2. Additional License Terms Pertaining to LabChart Products

ADInstruments hereby grants Licensee a license to install and use any LabChart product(s) for which Licensee has purchased a license (including LabChart, LabChart Pro, LabChart Modules, LabChart Extensions, GLP Client, and Scope) on up to three (3) Computers for the purpose of data analysis. Of these three Computers, Licensee may use only one (1) for the purpose of data acquisition, which must be done using a device or devices authorized by ADInstruments ("Authorized Recording Device"), such as a PowerLab unit. Licensee may purchase licenses for additional software seats (i.e., installation on additional Computers) for analysis purposes only. Each additional licensed LabChart product may only be installed on one (1) Computer. Licensee may not make LabChart products available to any other person or organization without the express written consent of ADInstruments. Licensee

may make copies of LabChart products for backup purposes. Backup copies of any LabChart product are to be used only to replace the original copy in the event that it is destroyed or becomes defective.

3. Additional License Terms Pertaining to LabChart Online

Licensee agrees, on behalf of Licensee and Authorized Users, to abide by copyright laws governing materials that are accessed on or downloaded from LabChart Online.

Licensee agrees, on behalf of Licensee and Authorized Users, that LabChart Online will not be used for confidential file sharing or for backup data storage. ADInstruments will take no responsibility, nor will it provide compensation, for any issues associated with data uploaded to, or downloaded from, LabChart Online.

Licensee agrees that ADInstruments retains the right to

- i) create limits regarding LabChart Online usage, such as, without limitation, file size;
- ii) restrict, suspend, or terminate any or all LabChart Online services at any time, without notification.

It shall be the responsibility of Licensee and Authorized Users to maintain the accuracy, completeness, confidentiality and current status of account information at all times. LabChart Online may not be accessed using any third party licensee's login and password. Licensee bears sole responsibility for all activity on Licensee's account. It is the responsibility of Licensee to ensure that all content generated by Licensee or Authorized Users is lawful according to the Licensee's local laws and regulations, and is appropriate for the audience who will view it.

If Licensee becomes aware of any unauthorized account use or other security breach, Licensee shall promptly notify ADInstruments. For purposes of security, ADInstruments may require Licensee to modify certain account information. ADInstruments reserves the right to investigate suspected breaches of these terms by Licensee and Authorized Users accessing LabChart Online. Inappropriate use of LabChart Online shall be grounds for immediate termination of Licensee's LabChart license, or, alternatively, at ADInstruments' discretion, the modification or removal of all or part of content generated by Licensee or Authorized Users.

4. Additional License Terms Pertaining to LabChart Pro Student License

The LabChart Pro Student License allows the Licensee to install and use LabChart Pro software on a single computer for educational purposes only. The license will expire six months after the license code is entered. The LabChart Pro Student License may not allow all the functionality of LabChart Pro. ADInstruments

reserves the right to add or remove features in the LabChart Pro Student License at any time, without notification.

5. Additional License Terms Pertaining to GLP Server License

ADInstruments hereby grants Licensee a license to install and use GLP Server on a single Computer that functions as a server to GLP Clients. Licensee may make copies of GLP server for backup purposes. Backup copies of GLP Server are to be used only to replace the original copy in the event that it is destroyed or becomes defective.

6. Additional License Terms Pertaining to LabTutor Suite Server

ADInstruments hereby grants Licensee a license to install and use LabTutor Server on a single Computer that functions as a server and that is located at a fixed location (i.e., not a mobile computing device). Licensee may make copies of LabTutor Server for backup purposes. Backup copies of LabTutor Software Suite are to be used only to replace the original copy in the event that it is destroyed or becomes defective. The above-referenced LabTutor Server software may be accessed by one or more client Computers. ADInstruments hereby grants Licensee a license to install LabTutor client software on an unlimited number of Computers that function as clients of the server on which Licensee has installed LabTutor Server software. Licensee may permit students, researchers, tutors and other users designated by Licensee (collectively, “Authorized Users”) to use LabTutor client software for purposes of completing work (including, but not limited to, conducting experiments) assigned by Licensee.

7. Additional License Terms Pertaining to LabTutor Online

Licensee may permit Authorized Users to access an authorized LabTutor Online server, provided that the number of such Authorized Users must not exceed the number of LabTutor Online licenses that Licensee has purchased. Licensee and Authorized Users whom Licensee permits to use the LabTutor Online server shall have access to the LabTutor Online server for twelve (12) consecutive months from the date that Licensee completes the LabTutor Online activation process (“Initial Term”). However, each individual LabTutor Online license is only valid for a six (6) month period from date of activation. If the Online Server or LabTutor Online licenses are deactivated due to their expiry or other reasons, the Licensee is not entitled to any reimbursement or refund of any fees or unused access time.

Licensee may renew the LabTutor Online license(s) at any time before the expiration of the Initial Term for an additional term of twelve (12) months (“Renewal Term”). The LabTutor Online server will be deactivated if not renewed. Unused licenses will expire

if not activated within twelve (12) months. At any time before the expiration of the then-current Renewal Term, Licensee may renew for a subsequent Renewal Term.

Licensee agrees, on behalf of Licensee and Authorized Users, to abide by copyright laws governing materials that are accessed on or downloaded from LabTutor Online.

Licensee agrees that ADInstruments retains the right to create reasonable limits regarding LabTutor Online usage, such as, without limitation, file size.

It shall be the responsibility of Licensee and Authorized Users to maintain the accuracy, completeness, confidentiality and current status of account information at all times. LabTutor Online may not be accessed using any third party licensee's login and password. Licensee bears sole responsibility for all activity on Licensee's account. It is the responsibility of Licensee to ensure that all content generated by Licensee or Authorized Users is appropriate for use in education.

If Licensee becomes aware of any unauthorized account use or other security breach, Licensee shall promptly notify ADInstruments. For purposes of security, ADInstruments may require Licensee to modify certain account information. ADInstruments reserves the right to investigate suspected breaches of these terms by Licensee and Authorized Users accessing LabTutorOnline. Inappropriate use of LabTutor Online shall be grounds for immediate termination of Licensee's LabTutor Online license, or, alternatively, at ADInstruments' discretion, the modification or removal of all or part of content generated by Licensee or Authorized Users.

8. Additional License Terms Pertaining to LabAuthor

ADInstruments hereby grants Licensee a license to install LabAuthor Software on one or more Computers for the purpose of creating or editing content for use with the licensee's Authorized LabTutor server. Licensee may make copies of LabAuthor for backup purposes. Backup copies of the LabAuthor Software are to be used only to replace the original copy in the event that it is destroyed or becomes defective.

9. LabTutor Images and Videos

- a. License. With respect to the images and videos provided to Licensee within the LabTutor experiments, Image and Media sections of LabAuthor, and LabTutor Image Gallery on ADInstruments' website ("Images" and "Videos"), ADInstruments hereby grants Licensee a non-transferable, non-sublicenseable, license to reproduce and use the Images and Videos solely for the following purposes (the "Permitted Uses"):
 - i. To include the Images in printed or electronic instructional/educational materials, such as laboratory handbooks or instructions for laboratory experiments, that are directly related to Licensee's authorized use of LabTutor or LabChart software packages in education.

-
- ii. To include the Videos solely in LabTutor experiments that Licensee creates using the LabAuthor software package.
 - iii. Other uses for which ADInstruments has provided Licensee with its prior written consent.
- b. Restrictions. All Permitted Uses shall be for non-profit, non-commercial, educational purposes only. This license is limited to existing non-profit licensees of the LabTutor software using LabAuthor. Commercial use of the Images or Videos is expressly forbidden. Unauthorized copying of the Images or Videos is expressly forbidden. ADInstruments and its licensors retain all rights in, title to, and ownership of the Images and Videos. Licensee shall take all steps reasonably necessary to protect ADInstruments' and its licensors' ownership rights.
- c. Copyright Notices. Licensee may not represent or cause others to believe that the Images or Videos are Licensee's original works, or that ADInstruments endorses or is affiliated with any entity, product or service. Licensee expressly agrees to display ADInstruments' (and third parties', if any) copyright and proprietary notice(s) with all of the Images and Videos, or any portion(s) thereof, that Licensee uses (e.g., image © ADInstruments 2010).
- d. Patent, Copyright and Trade Secret Indemnity. Licensee agrees to indemnify and hold harmless ADInstruments and its licensors against all liability resulting from or related to any claim of patent or copyright infringement, misappropriation, or misuse of trade secrets or other proprietary rights based upon Licensee's use of the Images or Videos, or any portion thereof, that is not in accordance with the terms of this Agreement.
- e. Third Party Images. Third party images, including, without limitation, historical images used in LabTutor Experiments that are not in the public domain are third party intellectual property. Accordingly, Licensee must obtain licenses to use Images that are not in the public domain from their respective third party owner(s). ADINSTRUMENTS HEREBY DISCLAIMS ALL LIABILITY FOR USER'S INFRINGEMENT OR OTHER VIOLATION OF THIRD PARTY RIGHTS IN THIRD PARTY IMAGES.

10. No Reverse Compiling

Licensee may not reverse engineer, decompile or disassemble the Software.

11. Intellectual Property

Except as expressly permitted by this Agreement, Licensee may not copy the Software. Except as otherwise noted in this Agreement, All ADInstruments software, hardware and documentation is the intellectual property of ADInstruments and is protected by copyright and other applicable intellectual property laws. Except as expressly

permitted by this Agreement, Licensee may not alter the Software in any way or create derivative works based on it. ADInstruments' company name, logo and product names constitute registered and common law trademarks of ADInstruments, and ADInstruments retains the exclusive ownership of, and rights to, such marks. All rights not expressly granted are reserved.

12. No Assignment

Licensee may not assign or otherwise transfer any of Licensee's rights under this Agreement. The Software may not be rented, leased, sub-licensed or loaned to any third party.

13. Limited Warranty

ADInstruments warrants the media on which the licensed Software is supplied to be free from defects in materials and workmanship under normal use for ninety (90) days from the date that ADInstruments invoices Licensee for such Software license.

EXCEPT FOR THE LIMITED WARRANTY EXPRESSLY SET FORTH HERE, THE LICENSED SOFTWARE, DOCUMENTATION, AND SUPPORT SERVICES, IF ANY, ARE PROVIDED TO USER ON AN "AS IS" AND "WHERE IS" BASIS AND WITHOUT WARRANTY OF ANY TYPE. THIS MEANS THAT ADINSTRUMENTS SHALL HAVE NO RESPONSIBILITY OR LIABILITY FOR, WITHOUT LIMITATION, ACCURACY OF DATA OR OTHER INFORMATION, DELETION OF DATA OR OTHER INFORMATION (INCLUDING INFORMATION PROVIDED BY ADINSTRUMENTS), DATA STORAGE OR TRANSMISSION FAILURES, SECURITY, OR PRIVACY.

ADINSTRUMENTS HEREBY EXPRESSLY DISCLAIMS AND EXCLUDES ALL WARRANTIES AND CONDITIONS, WHETHER STATUTORY, EXPRESS, IMPLIED, OR OTHERWISE, WITH RESPECT TO THE LICENSED SOFTWARE AND SUPPORT SERVICES, IF ANY, INCLUDING, BUT NOT LIMITED TO, ANY IMPLIED WARRANTY OF MERCHANTABILITY, FITNESS FOR A PARTICULAR PURPOSE, AND NON-INFRINGEMENT OF THIRD PARTY RIGHTS.

14. Limited Liability

ADINSTRUMENTS' MAXIMUM LIABILITY FOR ANY REASON ARISING OUT OF LICENSEE'S USE OF THE SOFTWARE WILL NOT EXCEED THE LICENSE FEE THAT LICENSEE PAYS ADINSTRUMENTS FOR USE OF THE SOFTWARE AT ISSUE. THE FOREGOING LIMITATION OF LIABILITY APPLIES NO MATTER WHAT THE CLAIM IS CALLED, WHETHER BREACH OF CONTRACT, INDEMNITY, BREACH OF WARRANTY, TORT, OR ANY OTHER NAME. UNDER NO CIRCUMSTANCES WILL ADINSTRUMENTS BE LIABLE FOR ANY INCIDENTAL, CONSEQUENTIAL OR SPECIAL DAMAGES RESULTING FROM USE OF THE SOFTWARE.

15. Upgrades

ADInstruments may make Upgrades to the Software from time to time. The terms of this Agreement shall apply to Upgrades.

16. Controlling Law

This Agreement shall be governed, construed and enforced in accordance with the laws of the territory into which the software is sold, or, if sold into the United States of America, by the laws of the State of California, excluding its conflicts of laws principles. The Licensee and the Licensor agree that conflict provisions of the governing law and United Nations Convention on Contracts for the International Sale of Goods shall not apply.

17. Severability

The finding by any court of competent jurisdiction that any provision of this Agreement or part thereof is unenforceable shall not affect the enforceability of the remaining provisions of this Agreement.

18. Termination

This Agreement is effective until terminated. Licensee may terminate this Agreement at any time by (i) permanently destroying all copies of the Licensed Software and documentation in Licensee's possession; (ii) uninstalling all components of the Licensed Software from Licensee's Computer(s); and (iii) notifying ADInstruments in writing of Licensee's intention to terminate this Agreement. ADInstruments may terminate this Agreement if (i) Licensee breaches the terms of this Agreement. Upon termination, all licenses granted herein shall immediately terminate.

19. Agreement Changes

ADInstruments may, at its discretion, change, modify, add or remove portions of the terms and conditions constituting this Agreement. ADInstruments will post any such updated terms and conditions at <http://www.adinstruments.com/license> at least thirty (30) days before any changes become effective.

Licensee's continued use of the Software following the posting of updated terms and conditions shall constitute Licensee's acceptance of such updates.

20. Complete Agreement

This Agreement constitutes the entire agreement between the parties. Amendments and modifications to this Agreement will not be accepted unless in writing and signed by an authorized representative of ADInstruments.

C007F

Copyright © ADInstruments Pty Ltd, 2000 - 2014. All rights reserved. PowerLab, MacLab, LabChart, LabTutor and LabAuthor are registered trademarks of ADInstruments Pty Ltd. Chart and Scope (application programs), LabTutor Server and LabTutor Online are trademarks of ADInstruments Pty Ltd. The names of specific recording units, such as PowerLab 16/35, are trademarks of ADInstruments Pty Ltd. Windows 8, Windows 7, Windows Vista and .NET Framework are trademarks of Microsoft Corporation. Apple, the Apple logo, MacOS, and Macintosh are trademarks of Apple Computer Inc. registered in the U.S. and other countries. Acrobat and Adobe are registered trademarks of Adobe Systems Incorporated. Igor is a trademark of Wavemetrics Inc. MATLAB is a registered trademark of The MathWorks Inc. Grass is a trademark of Astro-Med Inc. All other trademarks are the property of their respective owners.

