TABLE OF CONTENTS

1. Introduction and safety	5
1.1 Introduction	5
1.2 Symbols on Automower® 305	6
1.3 Symbols in the Operator's Manual	7
1.4 Safety instructions	8
2. Presentation	10
2.1 What's what?	11
2.2 Function	12
2.3 Search method	14
3. Installation	15
3.1 Preparations	15
3.2 Installation of the charging station	16
3.3 Charging the battery	18
3.4 Installation of the boundary wire	19
3.5 Connecting the boundary wire	25
3.6 Installation of the guide wire	26
3.7 Checking the installation	29
3.8 Linking Automower® 305 to the charging station	29
4. Use	30
4.1 Charging a discharged battery	30
4.2 Using the timer	31
4.3 Starting	31
4.4 Stopping	31
4.5 Switching off	31
4.6 Adjusting the cutting height	32
5. Control panel	33
5.1 Operation selection	34
5.2 Multi-choice buttons	34
5.3 Numbers	35
5.4 Main switch	35
6. Menu functions	36
6.1 Main menu	36
6.2 Menu structure	37
6.3 Timer (1)	38
6.4 Installation (2)	38
6.5 Security (3)	41
6.6 Settings (4)	43
7. Garden example	44
8. Maintenance	47
8.1 Battery	47
8.2 Winter storage	48
8.3 Service	48
8.4 After winter storage	48
8.5 Cleaning	48
8.6 Transport and removal	49
8.7 In the case of thunderstorms	49
8.8 Replacing the blades	50
9. Trouble shooting	51
9.1 Messages	51
9.2 Symptom	53
10. Technical data	54
11. Environmental information	54
12. EU declaration of conformity	55

MEMO

Serial number:	_____
PIN code:	_____
Dealer:	_____
Dealer's telephone number:	_____

If the mower is unexpectedly stolen, it is important to notify your dealer of this. Provide the serial number of the mower so that it can be registered as stolen in the central systems at Husqvarna AB. It is an important step in theft protection procedure which reduces interest in the buying and selling of stolen mowers.

www.automower.se

1. Introduction and safety

1.1 Introduction

Congratulations on your choice of an exceptionally high quality product. To get the best results from your Husqvarna Automower® 305 requires knowledge of its function. This Operator's Manual contains important information about the mower, how it must be installed and how to use it.

Husqvarna AB has a policy of continuous product development and therefore reserves the right to modify the design and appearance and function of products without prior notice.

The following system is used in the Operator's Manual to make this easier:

- Text written in *italics* is a text that is shown on the mower's display or is a reference to another section of the Operator's Manual.
- Words written in **bold** are one of the buttons on the mower's keypad.
- Words written in *UPPERCASE* and *italics* refer to the position of the main switch and the different operating modes on the mower.

IMPORTANT INFORMATION

Read through the Operator's Manual carefully and understand the content before using your Automower® 305.



WARNING

Automower® 305 can be dangerous if incorrectly used.

1. INTRODUCTION AND SAFETY

1.2 Symbols on Automower® 305

These symbols can be found on the robotic lawn mower. Study them carefully.

- Read through the Operator's Manual carefully and understand the content before using your Automower® 305.
- The warnings and safety instructions in this Operator's Manual must be carefully followed if the mower is to be used safely and efficiently.
- Automower® 305 can only start when the main switch is moved to the 1 position and the correct PIN code has been entered. Inspection and/or maintenance must be carried out with the main switch set to 0.
- Keep your hands and feet away from the rotating blades. Never place your hands or feet close to or under the body when Automower® 305 is in operation.
- Do not ride on Automower® 305.
- This product conforms to the applicable EU Directives.
- This product must be left at an appropriate recycling station.

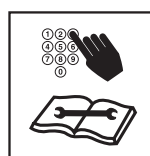

1. INTRODUCTION AND SAFETY

1.3 Symbols in the Operator's Manual

These symbols can be found in the Operator's Manual. Study them carefully.

- Turn the main switch to 0 before carrying out any inspections and/or maintenance.

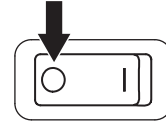

- Always wear protective gloves when working with the mower's underframe.



- Never use a high-pressure washer or even running water to clean Automower® 305.

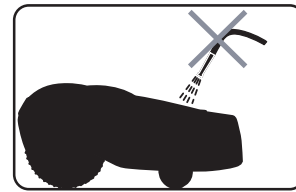

- A warning box indicates a risk of personal injury exist, especially when the stated instructions are not followed.



- An information box indicates a risk of material damage exist, especially when the stated instructions are not followed. The box is also used where there is a risk of user error.

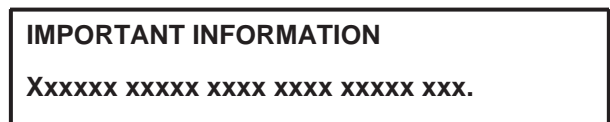

1. INTRODUCTION AND SAFETY

1.4 Safety instructions

Use

- Please read the Operator's Manual carefully and make sure you understand the instructions before using Automower® 305.
- It is not permitted to modify the original design of Automower® 305. All modifications are made at your own risk.
- Check that there are no stones, branches, tools, toys or other objects on the lawn that can damage the blades and cause the mower to stop.

Start Automower® 305 according to the instructions. When the main switch is in the 1 position make sure to keep your hands and feet away from the rotating blades. Never put your hands and feet under the mower.

- Never lift up Automower® 305 or carry it around when the main switch is in the 1 position.
- Do not let persons who do not know how Automower® 305 works and behaves use the mower.
- Never use Automower® 305 if persons, especially children, or pets, are in the immediate vicinity.
- Do not put anything on top of Automower® 305 or its charging station.
- Do not allow Automower® 305 to be used with a defective blade disc or body. Neither should it be used with defective blades, screws, nuts or cables.
- Do not use Automower® 305 if the main switch does not work.
- Always switch off Automower® 305 using the main switch when you do not intend to use the mower. Automower® 305 can only start when the main switch is set to 1 and the correct PIN code has been entered.
- Automower® 305 must never be used at the same time as a sprinkler. In this case use the timer function, see 6.3 *Timer (1)*, so the mower and sprinkler never run simultaneously.
- Husqvarna AB does not guarantee full compatibility between Automower® 305 and other types of wireless systems such as remote controls, radio transmitters, buried electric animal fencing or similar.
- If there is risk for thunder, the transformer should be disconnected from the power and the boundary wire from the charging station.

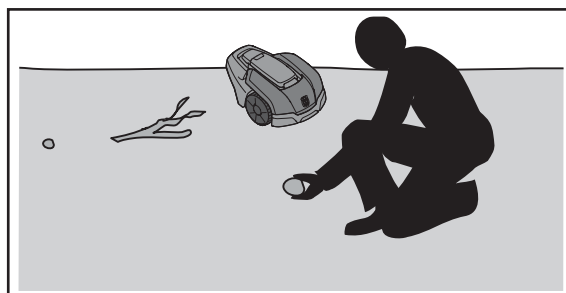

1. INTRODUCTION AND SAFETY

Transport

The original packaging should be used when transporting Automower® 305 over long distances.

To safely move from or within the working area:

1. Press the **STOP** button to stop the mower. If security is set to the medium or high level (see 6.5 *Security*), the PIN code has to be entered. The PIN code has four digits and is chosen when the mower is started for the first time, see 3.8 *Linking Automower® 305 to the charging station*.
2. Set the main switch to 0 if the mower must be carried.
3. Carry the mower by the handle at the rear under the mower. Carry the mower with the blade disc away from the body.

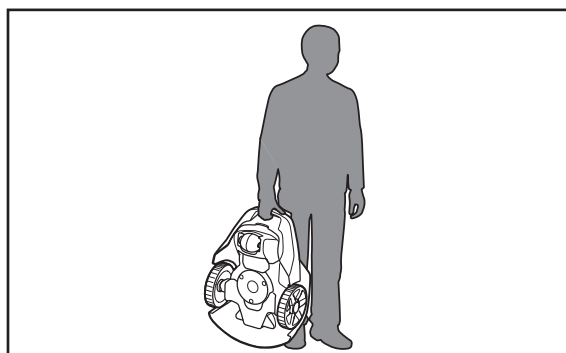
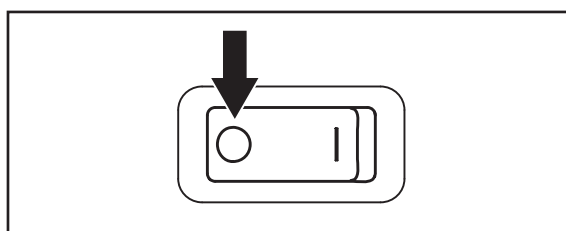
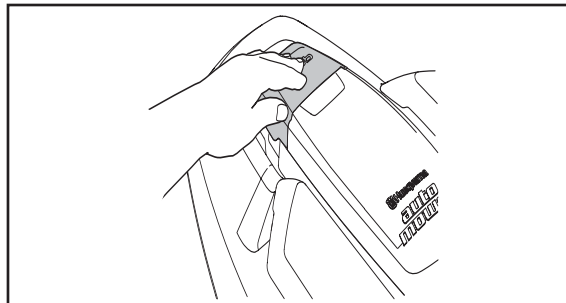

IMPORTANT INFORMATION

Do not lift the mower when it is parked in the charging station. This may damage the charging station and/or the mower.

Maintenance



WARNING

When the mower is turned upside down the main switch must always be set to the 0 position.

The main switch should be set to the 0 position during all work on the mower's underframe, such as cleaning or replacing the blades.

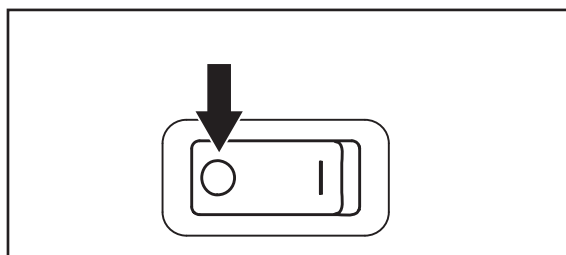

- Inspect Automower® 305 each week and replace any damaged or worn parts.

Check especially that the blades and blade disc are not damaged. Replace all blades and screws at the same time if necessary so that the rotating parts are balanced, see 8.8 *Replacing the blades*.

2. PRESENTATION

2. Presentation

This chapter contains information that is important to be aware of when planning the installation.

An installation of Husqvarna Automower® 305 includes four main components:

- Automower® 305, an robotic lawn mower that mows the lawn by moving in essentially an irregular pattern. The mower is powered by a maintenance-free battery.

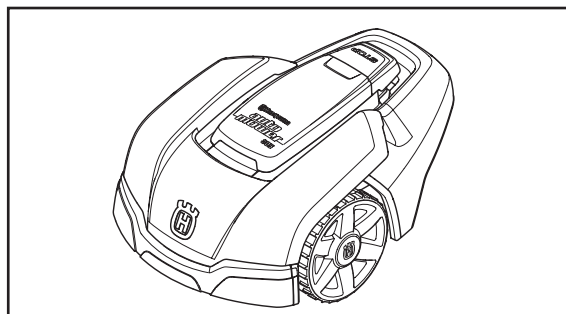

- Charging station, where your Automower® 305 returns when the charge level in the battery becomes too low.

The charging station has three functions:

- To send control signals along the boundary wire.
 - Sending control signals in the guide wire so that Automower® 305 can find the charging station.
 - To charge Automower® 305 battery.
- Transformer, which is connected between the charging station and a 230V wall socket. The transformer is connected to the wall socket and to the charging station using a 10 m long low voltage cable. The low voltage cable must not be shortened nor extended. A longer low voltage cable is available as option. Please contact your dealer for more information.

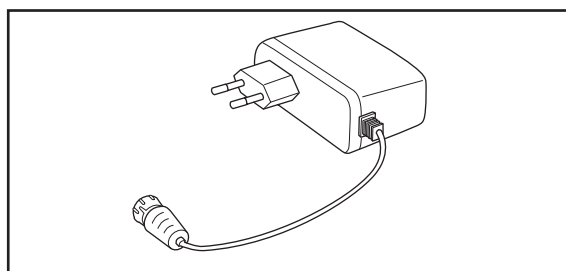
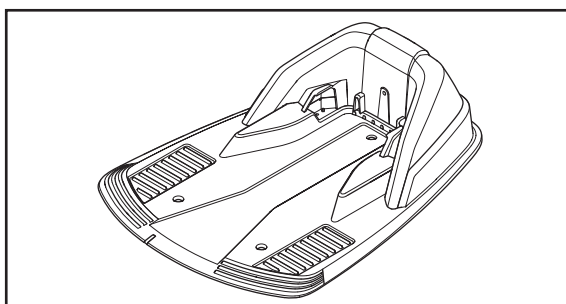

- Wire, laid in a loop around Automower® 305 working area. The boundary wire is laid around the edges of the lawn and around objects and plants that the mower must not run into. The wire is also used as the guide wire.

The wire supplied with the installation is 150 m long. If this is not sufficient more wire can be purchased, with a connector, and spliced onto the existing wire.

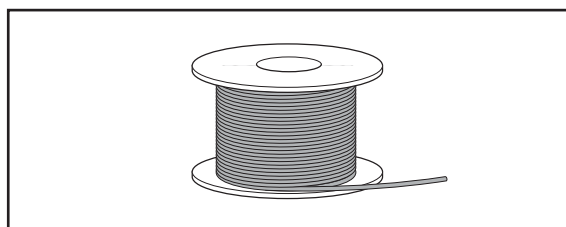

2. PRESENTATION

2.1 What's what?

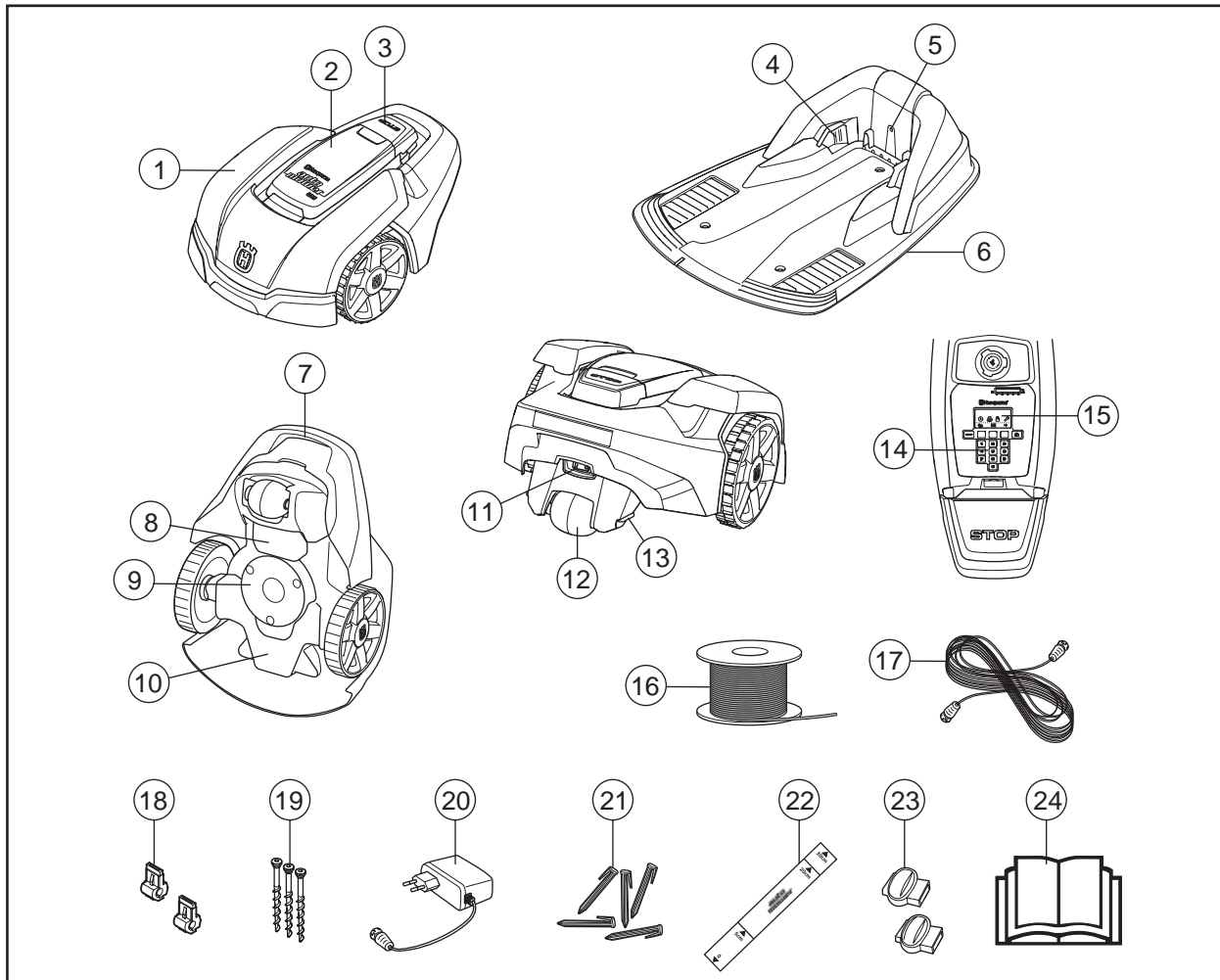

The numbers in the picture correspond to:

- | | |
|----------------------------------------------------------------------------------|-----------------------------------------------------------------------------------------------------------------------|
| 1. Body | 14. Keypad |
| 2. Cover to display, keypad and cutting height adjustment | 15. Display |
| 3. Stop button/Lock button for opening the cover | 16. Loop wire for boundary wire and guide wire |
| 4. Contact strip | 17. Low voltage cable |
| 5. LED for operation check of the charging station, boundary wire and guide wire | 18. Connector for the loop wire |
| 6. Charging station | 19. Nails for securing the charging station |
| 7. Handle | 20. Transformer |
| 8. Battery cover | 21. Staples |
| 9. Blade disc | 22. Measurement gauge for help when installing the boundary wire (the measurement gauge is broken loose from the box) |
| 10. Chassis box with electronics, battery and motors | 23. Coupler for the loop wire |
| 11. Main switch | 24. Operator's Manual |
| 12. Rear wheel | |
| 13. Charging strip | |

2. PRESENTATION

2.2 Function

Capacity

Automower® 305 is recommended for lawns up to 500 m² in size.

How big an area Automower® 305 can keep cut depends primarily on the condition of the blades and the type, growth and moisture of the grass. The shape of the garden is also significant. If the garden mainly consists of open lawns, Automower® 305 can mow more per hour than if the garden consists of several small lawns separated by trees, flower beds and passages.

How long Automower® 305 mows and recharges can vary depending on, among others, the ambient temperature. A fully charged Automower® 305 mows for 40 to 50 minutes, depending on the age of the battery and how thick the grass is. The mower then charges for 120 to 150 minutes depending on the age of the battery and the ambient temperature.

Mowing technique

The mowing system used by Automower® 305 is based on an effective and energy efficient principle. Unlike normal robotic lawn mowers, Automower® 305 cuts the grass instead of striking it off.

We recommend you allow Automower® 305 to mainly mow in dry weather to obtain the best possible result. Automower® 305 can even mow in the rain, however, wet grass easily collects on the mower and the risk of slipping on steep slopes is greater.

The blades must be in good condition to obtain the best mowing result. In order to keep the blades sharp for as long as possible it is important to keep the lawn free from branches, small stones and other objects.

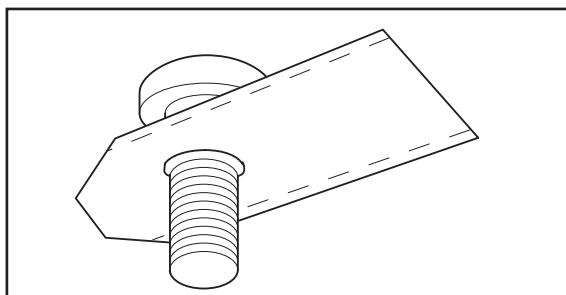

2. PRESENTATION

Working method

Automower® 305 automatically mows the lawn. It continuously combines mowing and charging.

The mower starts to search for the charging station when the battery charge becomes too low. Automower® 305 does not mow when it is searching for the charging station.

When Automower® 305 searches for the charging station, it first searches irregularly for the guide wire. Then it follows the guide wire to the charging station, turns around just in front of the station and backs into it.

When the battery is fully charged, the mower leaves the charging station and starts mowing in a randomly selected direction within the 90° to 270° exit sector.

In order to ensure an even cut, even in parts of the garden that are hard to reach, there are a number of manual settings for how the mower is to leave the charging station, see 6.4 *Installation (2)*.

When Automower® 305 body hits an obstacle, the mower reverses and selects a new direction.

Two sensors, one at the front and one at the back on Automower® 305, sense when the mower approaches the boundary wire. Automower® 305 overruns the wire by up to 28 centimetres before it turns.

The **STOP** button on the top of Automower® 305 is mainly used to stop the mower when it's running. When the **STOP** button is pressed a cover opens, behind which there is a control panel. The **STOP** button remains depressed until the cover is closed again. This acts as start inhibitor.

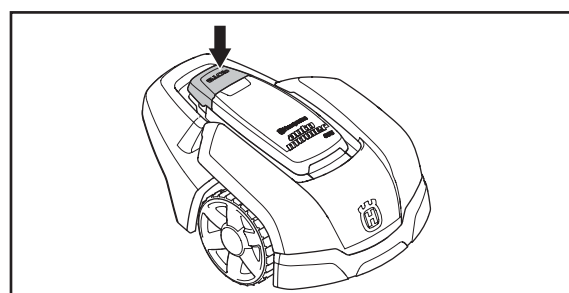
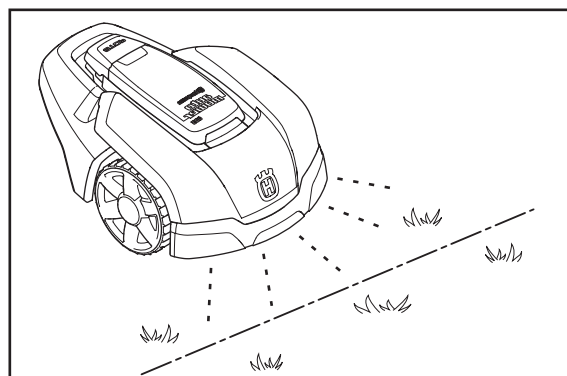
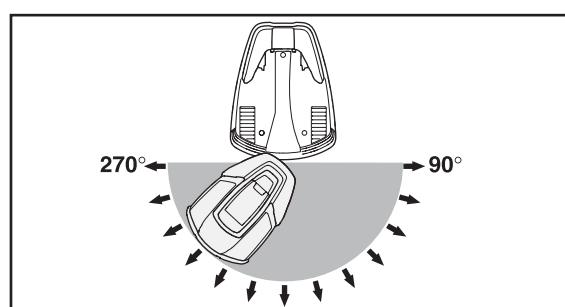
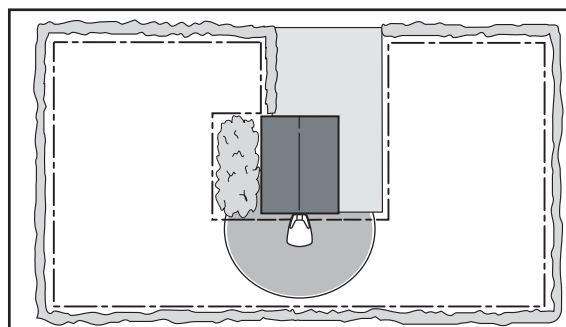

2. PRESENTATION

The control panel on the top of Automower® 305 is where you manage all the mower settings. Open the control panel cover by pressing down the **STOP** button.

When the main switch is set to position 1 for the first time, a start-up sequence begins which includes: language selection, time format, date format and the four-digit PIN code and setting the time and date, see *3.8 Linking Automower® 305 to the charging station*

After this, the selected PIN code must be entered every time the main switch is set to 1. See *6.5 Security* for more information on theft protection.

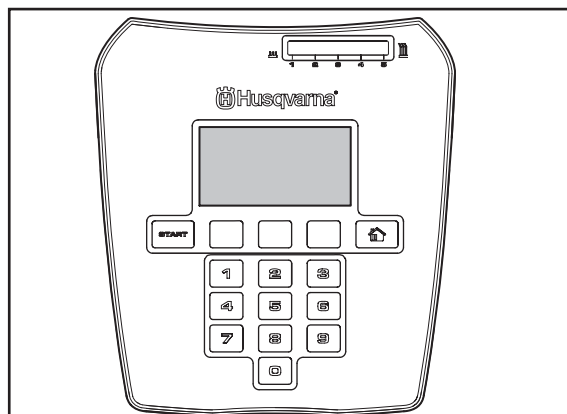

Movement pattern

The mower's movement pattern is irregular and is determined by Automower® 305 itself. A movement pattern is never repeated. This mowing system means the lawn is mown equally without any mowing lines.

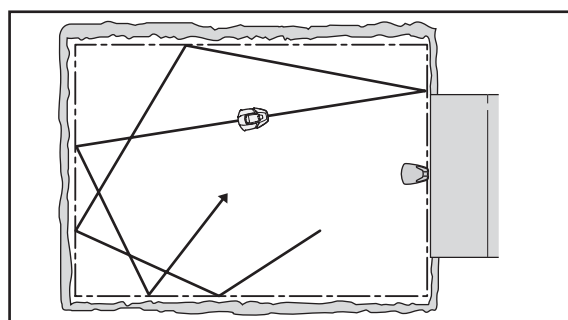

2.3 Search method

Automower® 305 runs irregularly until it reaches the guide wire. The mower then follows the guide wire in to the charging station.

The guide wire is a cable that is laid from the charging station towards, for instance, a remote part of the working area or through a narrow passage to be then connected with the boundary wire. For more information, see *3.6 Installation of the guide wire*

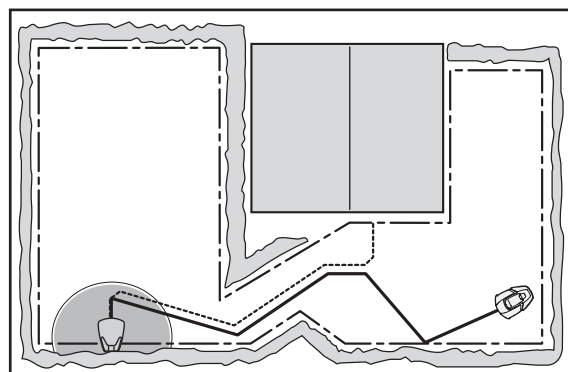

3. INSTALLATION

3. Installation

This chapter describes how you install the Husqvarna Automower® 305. Before starting the installation read the previous chapter 2. *Presentation*.

Read also through this entire chapter before beginning the installation. How the installation is made also affects how well Automower® 305 will work. It is therefore important to plan the installation carefully.

Planning is simplified if you make a sketch of the working area, including all obstacles. This makes it easier to see the ideal positions for the charging station, the boundary wire and the guide wire. Draw on the sketch where the boundary and guide wires should be routed.

Carry out the installation in the following steps:

- 3.1 Preparations.
- 3.2 Installation of the charging station.
- 3.3 Charging the battery.
- 3.4 Installation of the boundary wire.
- 3.5 Connecting the boundary wire.
- 3.6 Installation of the guide wire.
- 3.7 Checking the installation.
- 3.8 Linking Automower® 305 to the charging station.

The charging station and boundary and guide wires must be connected to be able to carry out a complete start-up of Automower® 305. If however the mower has to be started without the entire loop installation in place, a shorter temporary boundary wire and guide wire can be connected to the charging station.

3.1 Preparations

1. If the lawn in the proposed working area is taller than 10 cm, mow it using a normal robotic lawn mower. Then collect the clippings.
2. Read carefully through all the steps before the installation.
3. Check that all parts for the installation are included:

The numbers in brackets refer to the detail diagram 2.1 *What's what?*.

- Operator's Manual (24)
- Automower® 305
- Charging station (6)
- Loop wire for the boundary wire and guide wire (16)

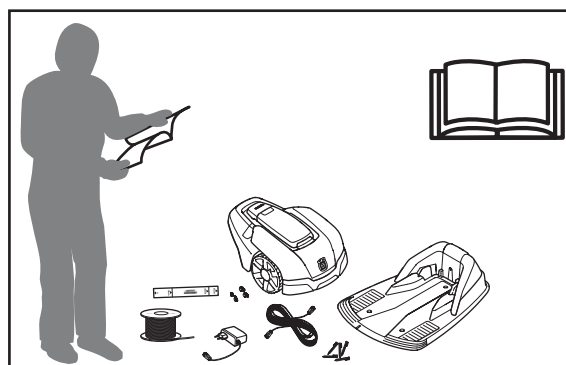

3. INSTALLATION

- Transformer (20)
- Low voltage cable (17)
- Staples (21)
- Connector for the loop wire (18)
- Screws for the charging station (19)
- Measurement gauge (22)
- Solderless coupler for the loop wire (23)

During installation you will also need: A hammer to knock the staples into the ground, combination pliers, and a straight spade if the boundary wire is to be buried.

3.2 Installation of the charging station

Ideal position of the charging station

For examples of where best to install the charging station, See 7. *Garden example*.

The charging station must be positioned with a great deal of free area in front of it (at least 3 metres). It should also be centrally placed in the working area so that Automower® 305 finds it easier to reach all areas in the working area.

It is a good idea to place the charging station in the shadow. The battery is spared if it is charged in the lowest possible ambient temperature.

Do not put the charging station in a corner or pocket in the working area. There must be a straight boundary wire, at least 2 metres long, to the right and left of the charging station.

The charging station must be positioned on relatively level ground. The front end of the charging station must be a maximum of 3 cm higher than the back end. The front end of the charging station must never be lower than the back end.

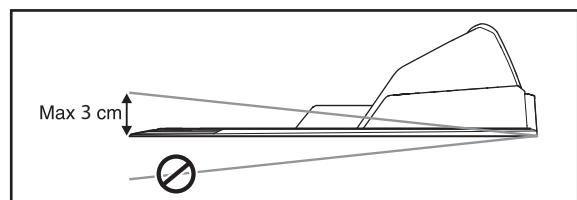
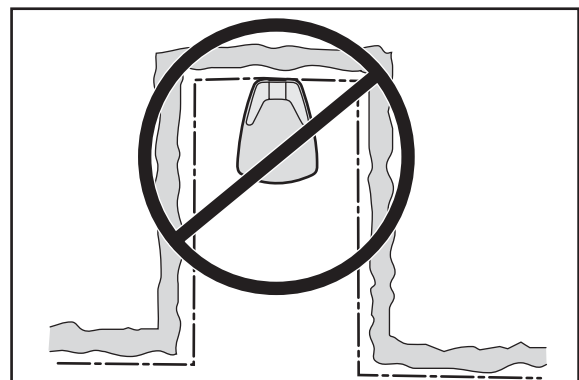
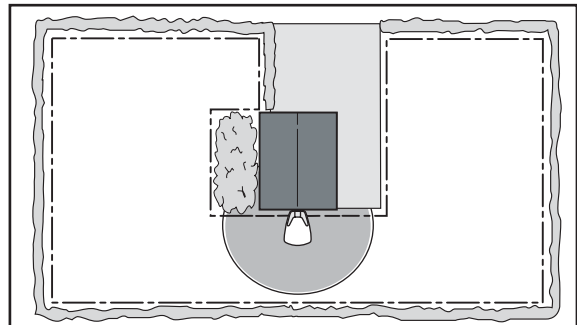

3. INSTALLATION

The charging station must not be positioned so that its plate bends.

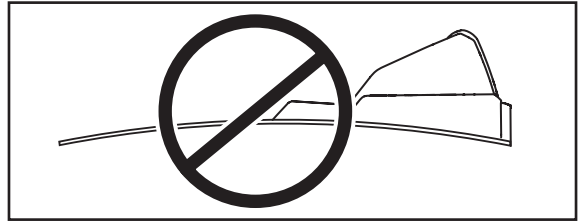

Consider the distance to a wall socket when selecting a location for the charging station. The charging station must be connected to a 230 V wall socket via the transformer. The low voltage cable for the transformer is 10 metres long but other lengths are available as option. Please contact your dealer for more information.

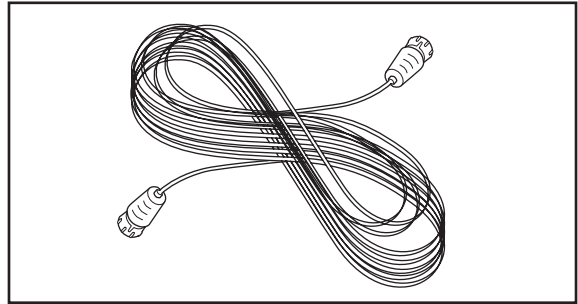

IMPORTANT INFORMATION

The low voltage cable must not be shortened nor extended.

Tip! It is possible to let the low voltage cable cross the working area. It must then be either stapled down or buried. In some cases there is a better positioning option for the charging station than close to a house

The transformer must be placed where it is well ventilated and is not exposed to direct sunlight. It is also beneficial if the transformer can be placed under a roof.

It is recommended to use an earth fault-breaker when connecting the transformer to the wall socket.

Avoid placing the charging station in a narrow passage (narrower than about 3 metres).

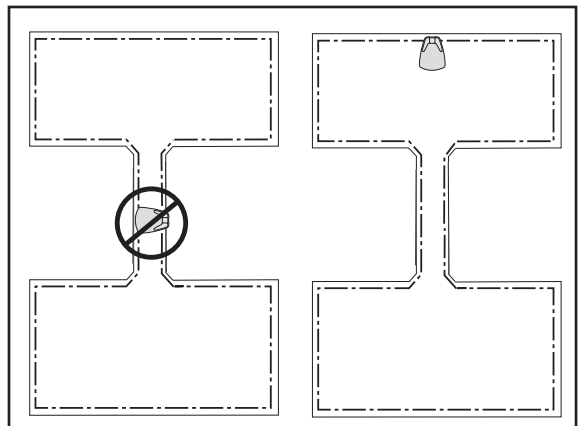

3. INSTALLATION

Installation and connecting the charging station

1. Position the charging station in a suitable spot.
2. Attach the charging station to the ground using the supplied screws.
3. Ensure the screws are secured all the way down in the countersink.

IMPORTANT INFORMATION

It is not permitted to make new holes in the plate. Only the existing holes may be used to secure the plate to the ground.

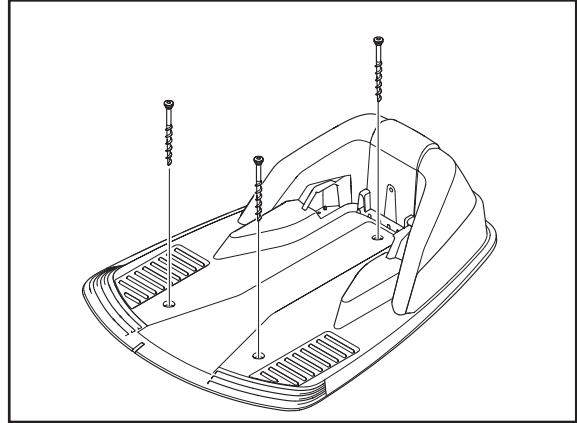

4. Connect the low voltage cable to the charging station.
5. Connect the transformer's power cord to a 230V wall socket. If the wall socket is outdoors, it is important that the transformer is protected from direct sunlight.

IMPORTANT INFORMATION

The transformer may not be exposed to direct sunlight.

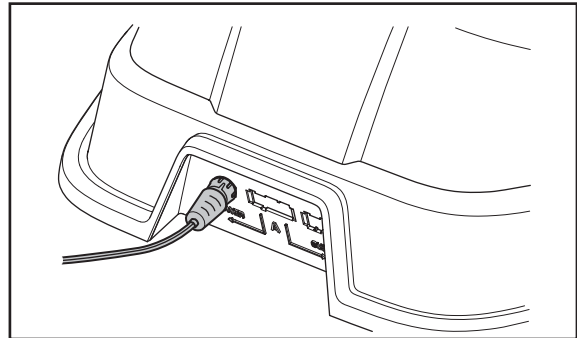

IMPORTANT INFORMATION

Do not tread or walk on the charging station plate.



3.3 Charging the battery

As soon as the charging station is connected, it is possible to charge the mower.

The mower can be charged as soon as the charging station is connected. Set the main switch to the 1 position.

Place Automower® 305 in the charging station to charge the battery while the boundary and guide wires are being laid.

If the battery is empty, it takes around 3 hours to fully charge it.

IMPORTANT INFORMATION

Automower® 305 cannot be used before the installation is complete.

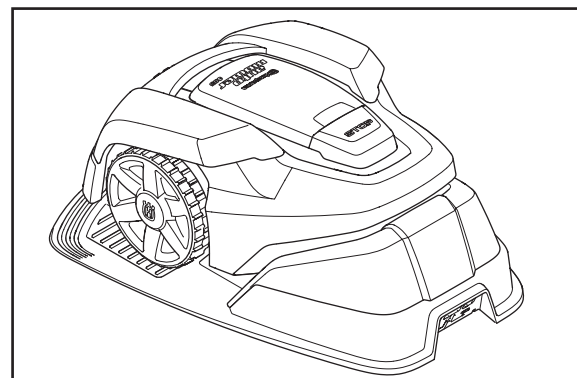

3. INSTALLATION

3.4 Installation of the boundary wire

The boundary wire can be installed in one of the following ways:

1. Securing the wire to the ground with staples.

It is preferable to staple down the boundary wire if you want to make adjustments to the boundary wire during the first few weeks of operation.

2. Bury the wire.

It is preferable to bury the boundary wire if you want to dethatch or aerate the lawn.

If necessary both methods can be combined so one part of the boundary wire is stapled down and the remainder is buried.

Best position for the boundary wire

The boundary wire should be laid so it:

- Forms a loop around the working area for Automower® 305. Only an original boundary wire must be used. This is tinned and has a high quality insulation to withstand the dampness in the ground.

Maintains a maximum distance of 15 metres from Automower® 305 in the entire working area.

Is a maximum of 250 metres long.

The boundary wire is laid at different distances from obstacles depending on what the working area borders. The picture below shows how the boundary wire should be routed around the working area and around obstacles.

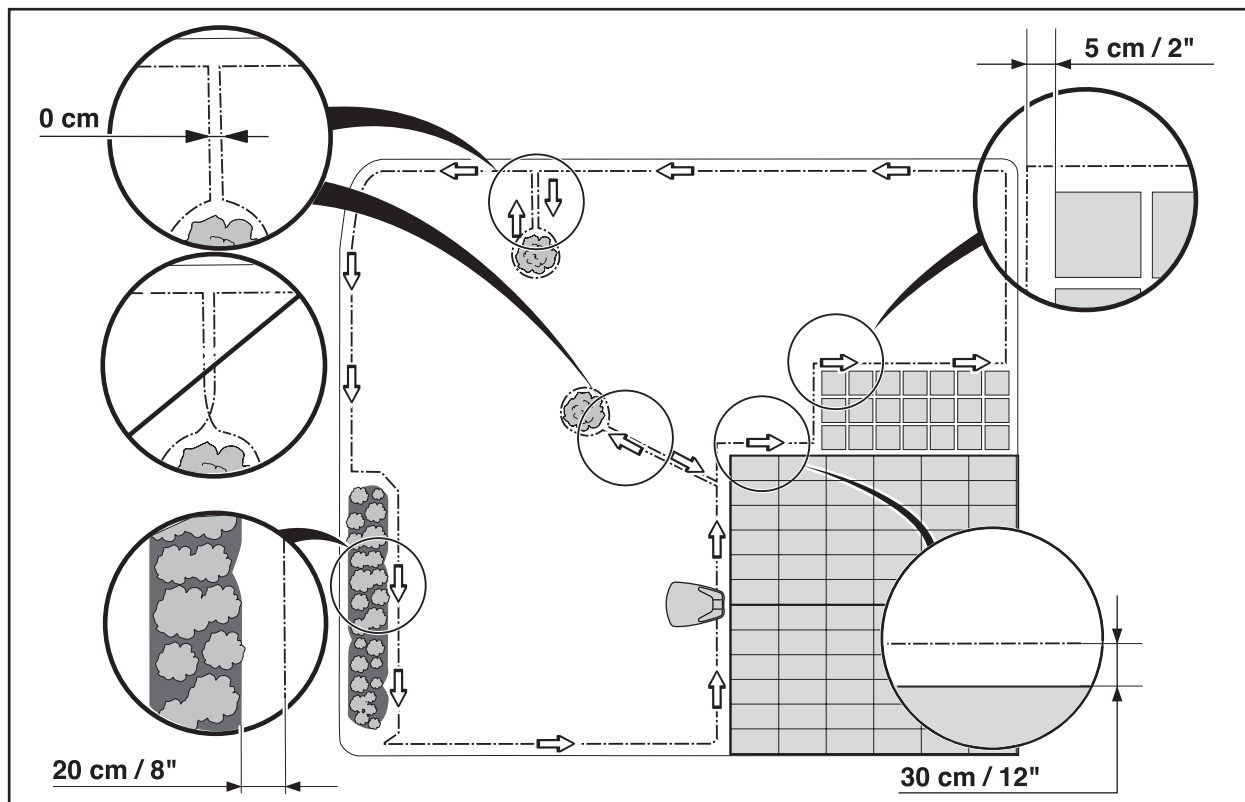

3. INSTALLATION

Boundaries for the working area

If a high obstacle, for example a wall or fence, borders the working area, the boundary wire should be laid 30 cm from the obstacle. This will prevent Automower® 305 from colliding with the obstacle and reduce body wear.

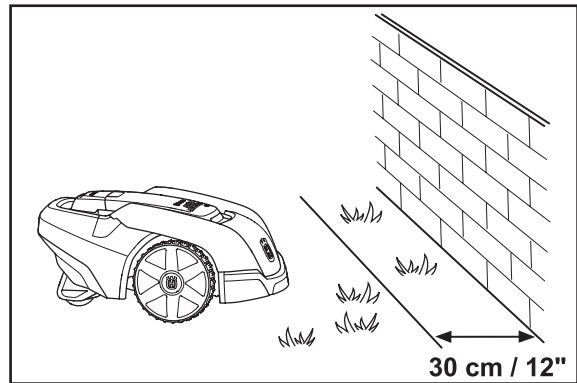

If the working area borders against a small ditch, for example, a flower bed or a small elevation, e.g. a low verge (3 - 5 cm), the boundary wire should be laid 20 cm inside the working area. This prevents the wheels from driving into the ditch or up onto the verge.

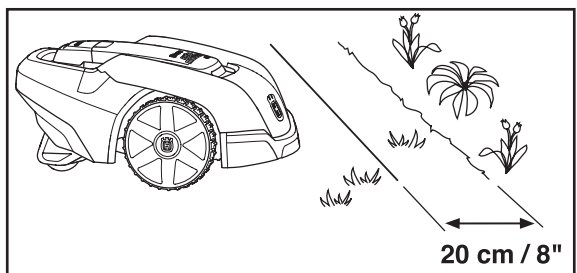

If the working area borders against a flat path or the like that lies level with the lawn, it is possible to allow Automower® 305 to run a little over the path. The boundary wire should then be laid 5 cm from the edge of the path.

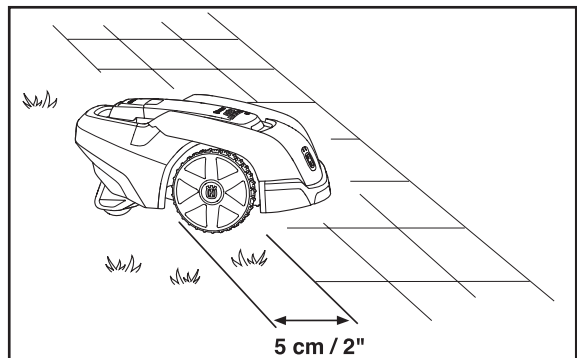

When the working area is divided by a flat slab path that is level with the lawn, it is possible to allow Automower® 305 to run over the path. It can be an advantage to lay the boundary wire under the slabs. The boundary wire can also be laid in the joint between the slabs.

Note! Automower® 305 must never run over a gravel path or similar material, which can damage the blades.

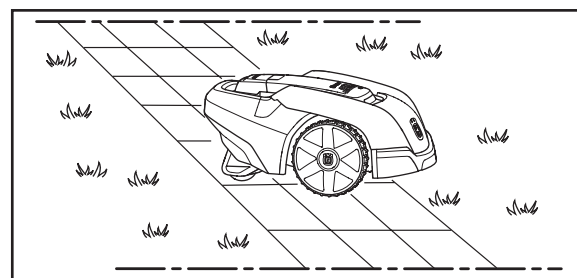

IMPORTANT INFORMATION

If the working area is adjacent to water bodies, slopes or precipices, the boundary wire should be supplemented with a fence or the like. The height must then be at least 15 cm. This will prevent Automower® 305 from ending up outside the working area under any circumstances.

3. INSTALLATION

Boundaries within the working area

Use the boundary wire to demarcate areas inside the working area by creating islands around obstacles that can not withstand a collision, for example, flower beds and fountains. Run the cable out to the area, route it around the area to be demarcated and then back along the same route. If staples are used, the wire should be laid under the same staple on the return route. When the boundary wire to and from the island are close together, the mower can drive over the wire.

Obstacles that can withstand a collision, for example, trees or bushes higher than 15 cm, do not need to be demarcated by the boundary wire. Automower® 305 will turn when it collides with this type of obstacle.

However, for the most gentle and silent operation, it is preferable to demarcate all fixed objects in and around the working area.

Obstacles that slope slightly, for example, stones or large trees with raised roots, should be demarcated or removed. Automower® 305 can otherwise slide up onto this kind of obstacle causing the blades to be damaged.

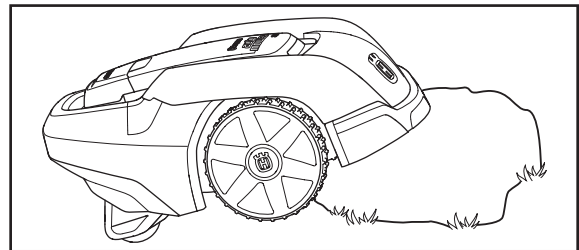
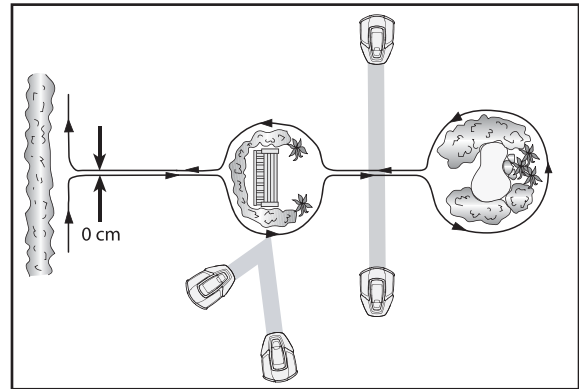

Secondary areas

It is recommended to create a secondary area when the working area is made up of two areas that are joined by a passage where the distance between the boundary wires is less than 60 cm. Run the boundary wire then around the secondary area so that it forms an island outside of the main area.

Automower® 305 must be moved manually between the main and secondary areas. Use the *MAN* operating mode when Automower® 305 shall mow a secondary area.

Instead of creating an island with the existing boundary wire, a secondary area generator can ideally be used. A secondary area generator can be purchased as an accessory. Contact your dealer for further information.

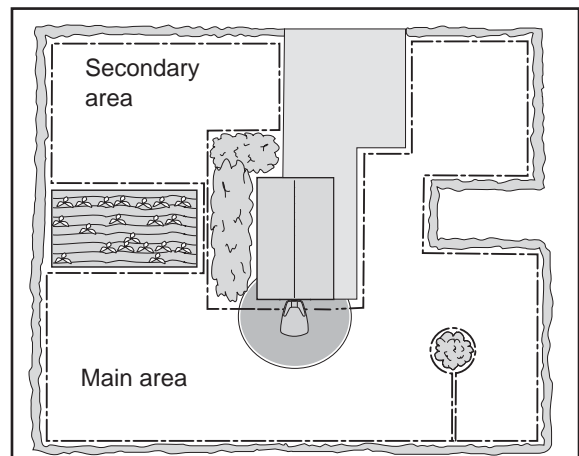

Passages when mowing

Long narrow passages and areas, narrower than 1.5 - 2 metres, should be avoided. When Automower® 305 mows there is a risk that it runs around in the passage or area for a too long. The lawn will then look flattened.

3. INSTALLATION

Slopes

The boundary wire can be laid across a slope that slants less than 10 %.

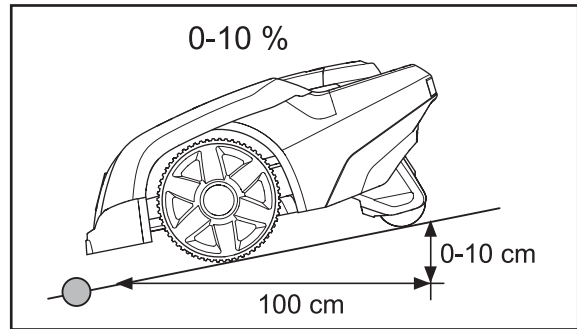

The boundary wire should not be laid across a slope that is steeper than 10 %. There is a risk of Automower® 305 finding it difficult to turn there. The mower will then stop and show the fault message *Outside working area*. The risk is at its greatest in damp weather conditions, as the wheels can slip on the wet grass.

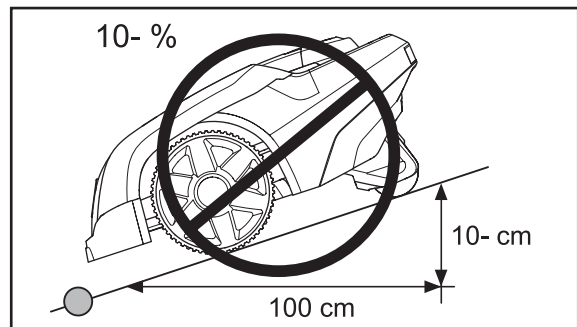

However, the boundary wire can be laid across a slope steeper than 10 % when there is an obstacle that Automower® 305 can be permitted to collide with, for example, a fence or a dense hedge.

Automower® 305 can mow areas inside the working area that slope up to 25 cm per distance metre (25 %). Areas that slope more must be demarcated by the boundary wire.

When any part of the working area's boundary slopes more than 10 cm per distance metre (10 %), the boundary wire must be routed about 20 cm in on flat ground before the slope starts.

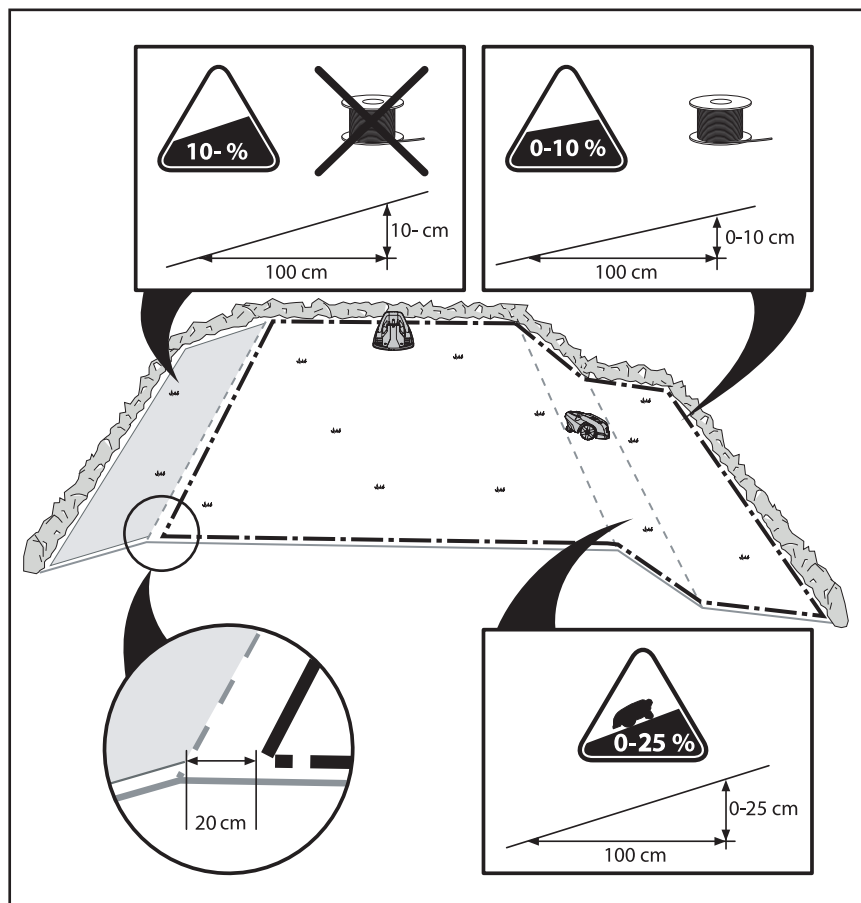

3. INSTALLATION

Laying out the boundary wire

Run the boundary wire around the working area, but wait before connecting the wire to the charging station.

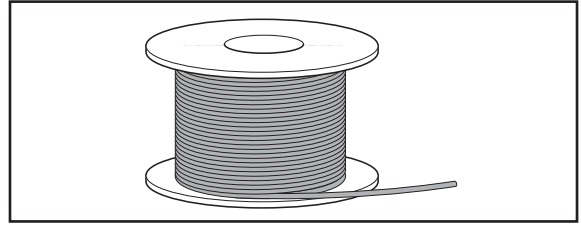

IMPORTANT INFORMATION

Extra wire must not be placed in coils outside the boundary wire. This can disrupt Automower® 305.

Tip! Use the supplied measurement gauge as a guide when you lay out the boundary wire. This helps you to easily set the correct distance between the boundary wire and the boundary/obstacle.

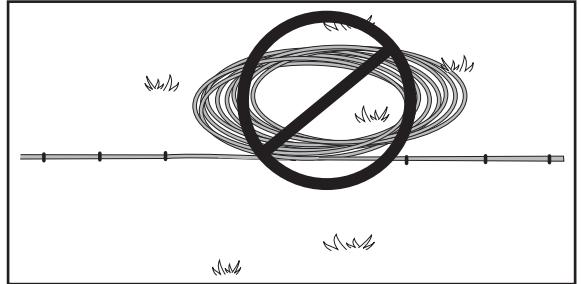

If you intend to staple down the boundary wire:

- Cut the grass very low with a standard robotic lawn mower or a trimmer where the wire is to be laid. It will then be easier to lay the wire close to the ground and the risk of the mower cutting the wire off is reduced.
- Make sure to lay the boundary wire tight to the ground and secure the staples close together with approximately 75 cm between each staple. The wire must generally lie close to the ground so, as not to be cut off before the grass roots have grown over it.
- Use a hammer to knock down the staples in the ground. Exercise care when knocking in the staples and make sure the wire is not under strain. Avoid forming the wire in sharp bends.

If the boundary wire is to be buried:

- Make sure to place the boundary wire at least 1 cm and a maximum of 20 cm into the ground.

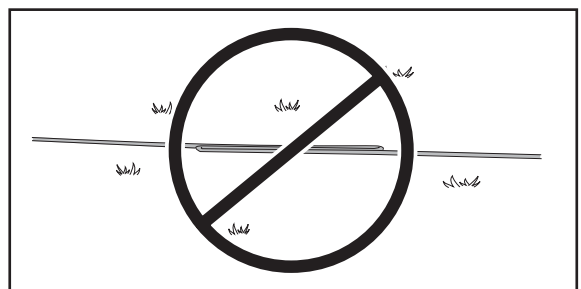

The boundary wire must not be crossed on the path to and from an island.

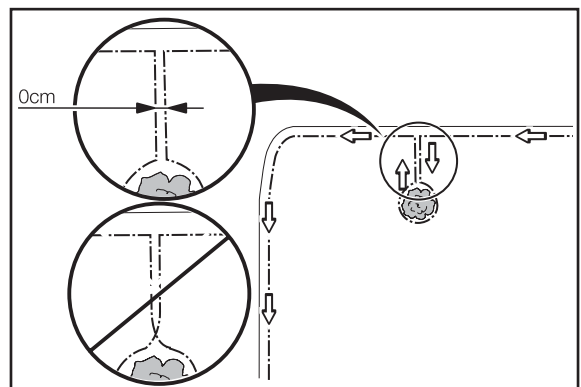

3. INSTALLATION

Laying the boundary wire in towards the charging station

The boundary wire must be laid completely outside the charging station (see figure below). If the boundary wire is laid in any other way, Automower® 305 may find it hard to enter the charging station.

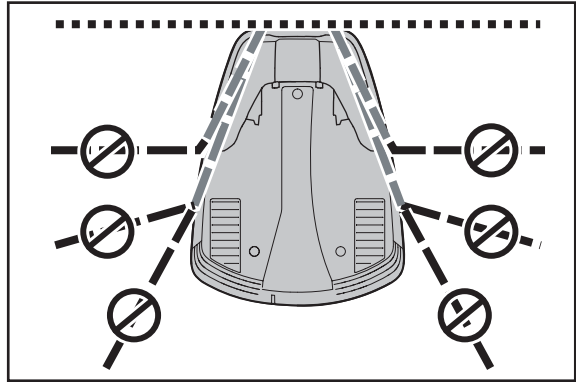

When connecting to the charging station, make sure that the boundary wire's right end is connected to the right hand pin and the left wire end to the left hand pin.

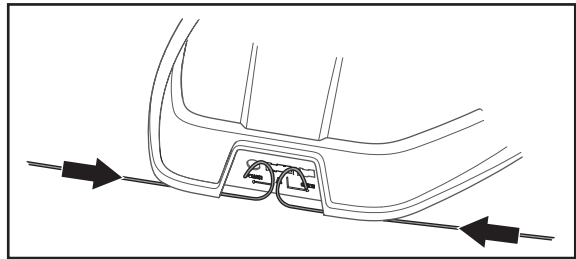

Joining the boundary wire

If the boundary wire is not long enough and needs to be spliced: Use original solderless coupler. It is waterproof and gives a reliable electrical connection.

To splice: Insert both cable ends in the coupler. Now press down the button on top of the connector fully. Use a pair of pliers or the like, as the button on the connector is difficult to press down by hand.

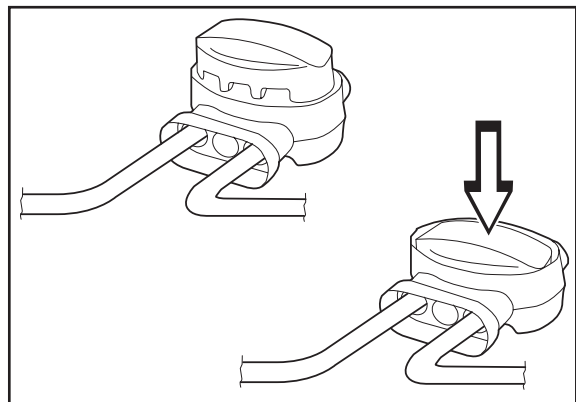

IMPORTANT INFORMATION

Twinned cables, or a screw terminal block that is insulated with insulation tape are not satisfactory splices. Soil moisture will cause the conductors to oxidise and after a while result in a broken circuit.

3. INSTALLATION

3.5 Connecting the boundary wire

Connect the boundary wire to the charging station:

IMPORTANT INFORMATION

The boundary wire must not be crossed when connecting to the charging station. Therefore the right hand wire end must be connected to the right hand connector on the charging station and vice versa.

1. Place the cable ends in the connector:
 - Open the connector.
 - Place the wire in the connector grip.
2. Press the connector together using a pair of pliers. Press until you hear a click.
3. Cut off any surplus boundary wire. Cut 1 - 2 cm above respective connectors.
4. Press the connector onto the contact pin, marked A, on the charging station.

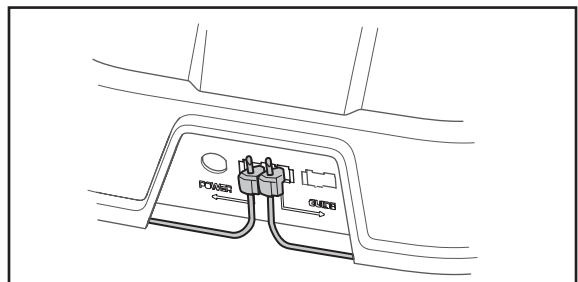
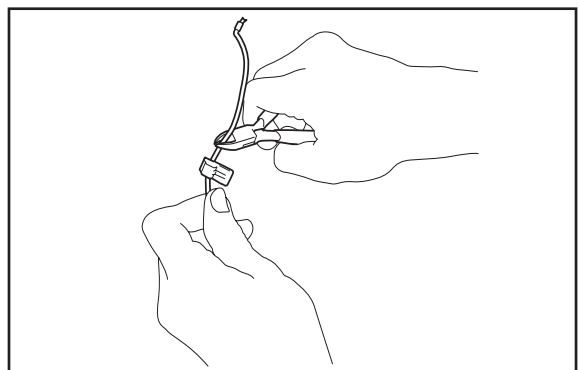
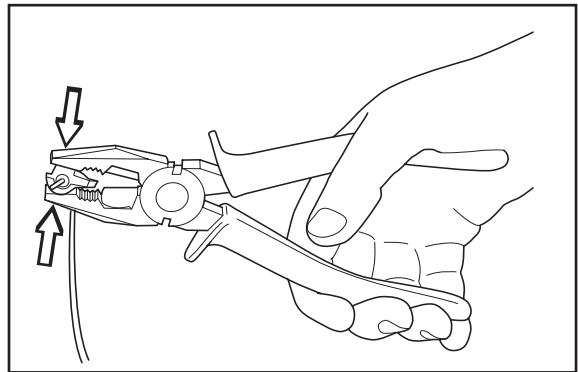
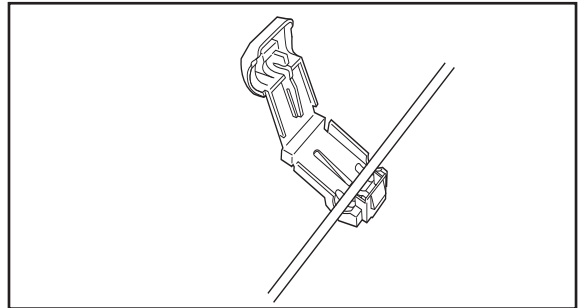

IMPORTANT INFORMATION

The right hand connector should be connected on the right hand contact pin on the charging station and vice versa.

3. INSTALLATION

3.6 Installation of the guide wire

The guide wire is a wire that is laid away from the charging station, for instance out towards a remote part of the working area or through a narrow passage and then connected with the boundary wire.

The same cable roll is used for both the boundary and guide wires.

The guide wire, as the boundary wire, can be stapled to or buried in the ground.

The guide wire is used by Automower® 305 to find its way back to the charging station but it also guides the mower to find its way from the charging station to remote areas of the working area. For more information about the *Remote start* function, see 6.4 *Installation (2)*

Placement and connection of the guide wire

1. Check that the charging station has the best placement.

The guide wire together with the part of the boundary wire that makes up the return to the charging station is known as the guide loop. The current in the guide loop always goes to the left in the connection between the guide wire and the boundary wire.

The adjoining picture shows what is considered a guide loop.

The picture is also a good example of an ideal position for the charging station to give the shortest possible guide loop.

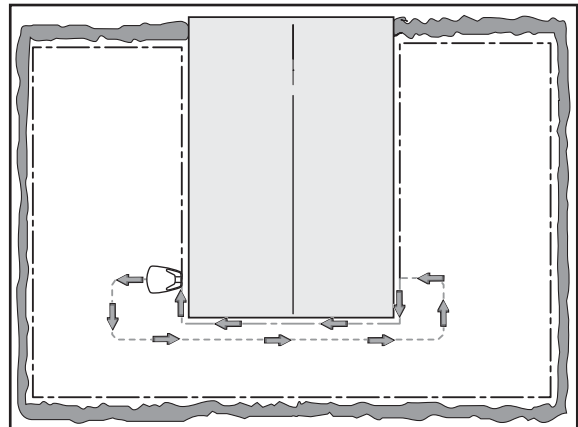

If the guide wire is longer than 250 metres, the mower may find it difficult to follow the wire. This varies depending on the design of the garden and installation.

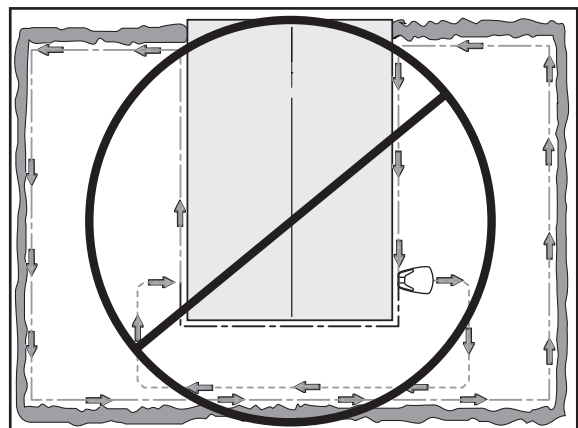

3. INSTALLATION

2. Draw the wire through the slot in the bottom of the charger plate.

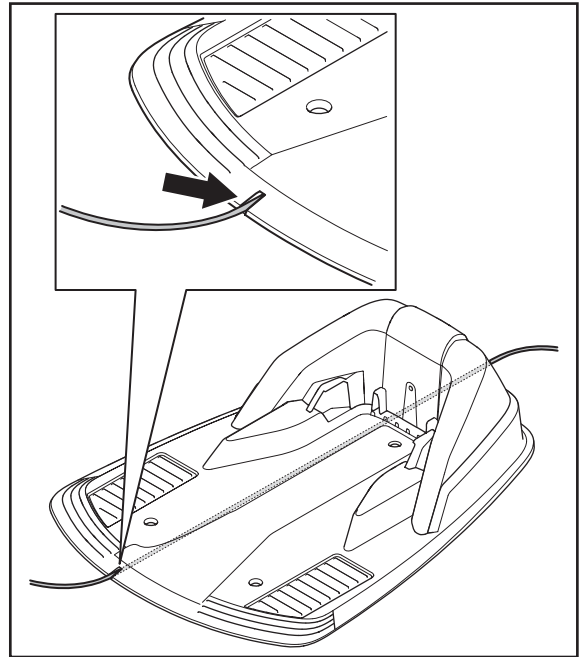

3. Fix a connector to the guide wire. Connect it to the contact pin on the charging station that is labelled "guide".

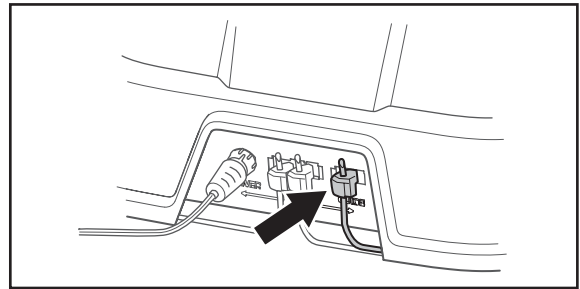

4. Route the guide wire at least 2 metres straight out from the front edge of the charging plate.

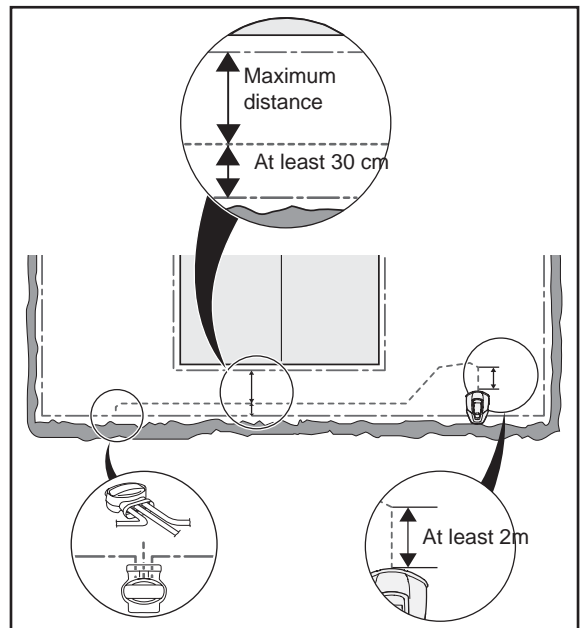

3. INSTALLATION

If the guide wire must be laid in a passage:

Automower® 305 follows the guide wire on the same side of the wire both to and from the charging station. This means that in towards the charging station the guide wire is on the right side of the mower and away from the charging station the guide wire is on the left side of the mower.

In the passage, the guide wire must be placed so that the mower has as much space to run as possible. The distance between the boundary wire and the guide wire must however be at least 30 cm (see the picture above).

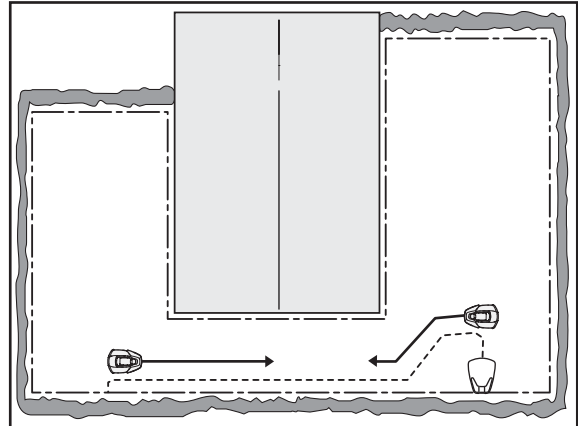

Avoid laying the wire at sharp angles. This can make it difficult for the mower to follow the guide wire.

5. Run the guide wire to the spot on the boundary wire where you want to make the connection.
6. Lift out the boundary wire. Cut off the boundary wire using a pair of wire cutters.

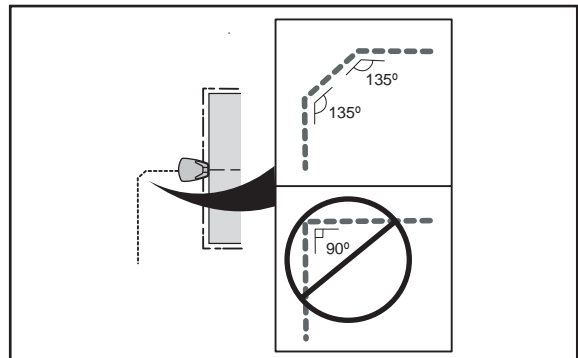

7. Connect the guide wire to the boundary wire with the help of a solderless coupler:

Insert the ends of the boundary wire in the right respective left-hand holes on the connector.

Insert the end of the guide wire in the centre hole.

Use pliers to completely compress the button on the connector.

8. Staple down/bury the connector in the lawn.

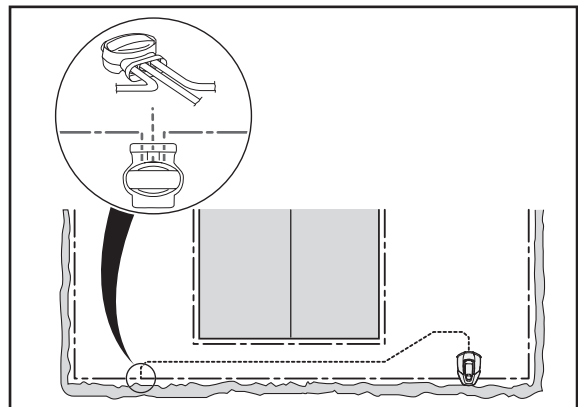

IMPORTANT INFORMATION

The function of the guide wire varies depending on how the working area appears. It is therefore recommended to test the installation with the help of the function *Test IN (2-3-1)*, see 6.4 *Installation (2)*.

IMPORTANT INFORMATION

The guide wire may not cross the boundary wire, for instance a boundary wire that is laid out to an island.

3. INSTALLATION

3.7 Checking the installation

Check the loop signal by inspecting the LED indicators on the charging station.

- Steady green light = good signals.
- Flashing blue light = interruption in the boundary wire, no signal.
- Flashing yellow light = interruption in the guide wire, no guide signal.
- Flashing red light = interruption in the charging station's antenna plate, no remote signal available. The fault should be rectified by an authorized dealer.
- Steady blue light = weak signal. This may depend on the boundary wire being over 250 m in length or that the wire is damaged. If the mower still works, this is not a problem.
- Steady red light = fault in a circuit board in the charging station. The fault should be rectified by an authorized dealer.

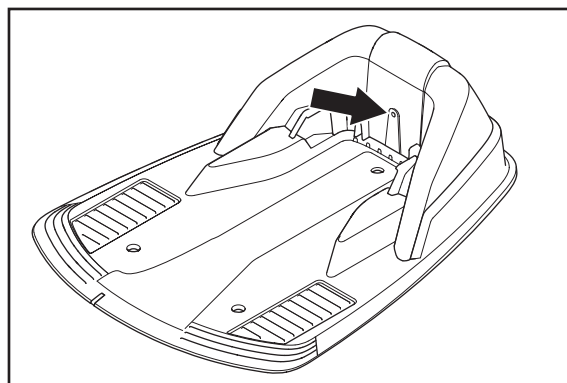

3.8 Linking Automower® 305 to the charging station

1. Set the main switch to the 1 position.
2. Place Automower® 305 in the charging station.
3. Open the control panel cover by pressing the **STOP** button.

A start-up sequence begins when Automower® 305 is started for the first time. The following is requested:

- Language
- Time format
- Correct time
- Date format
- Date
- Four-digit PIN code. All combinations except 0000 are permitted.

4. USE

4. Use

4.1 Charging a discharged battery

When Husqvarna Automower® 305 is new or has been stored for a long period the battery will not be charged and needs to be charged before starting. Charging takes 2 hours.

1. Set the main switch to the 1 position.
2. Place Automower® 305 in the charging station. Insert the mower as far as possible.

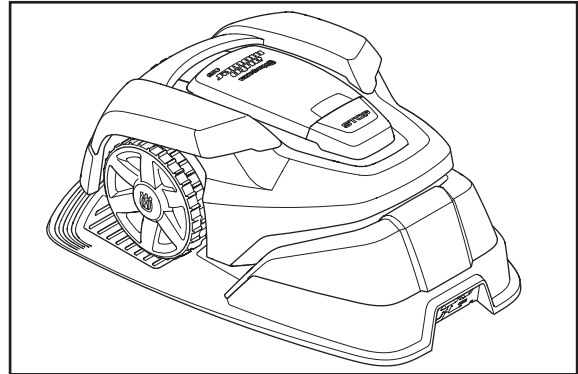

Good contact is made when both the charging strips on the mower touch the centre of the contact strips on the charging station.

3. Open the control panel cover. The display shows a message that charging is in progress.

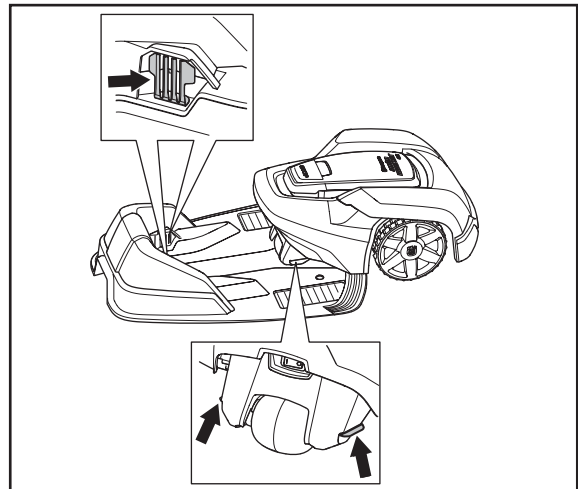

WARNING

Read the safety instructions before you start your Automower® 305.



WARNING

Keep your hands and feet away from the rotating blades.
Never put your hands or feet close to or under the body when the motor is running.



4. USE

4.2 Using the timer

The lawn should not be cut too often to obtain the best mowing result. Use the timer function (see 6.3 *Timer (1)*) to avoid a downtrodden lawn and to get the maximum life from your Automower® 305. When setting the timer, calculate that Automower® 305 mows around 20 m² per hour and day. For example; if the working area is 300 m², the mower must operate for 15 hours a day.

The quality of the grass improves if it is cut every other day instead of 12 hours every day. In addition, the grass benefits from resting completely during at least a three-day period once a month.

4.3 Starting

1. Set the main switch to the 1 position.
2. Press the **STOP** button to open the control panel cover.
3. Enter the PIN code.
The PIN code request can be disabled. For more information about theft protection, see 6.5 *Security (3)*.
4. Push the Start button.
5. Shut the cover within 10 seconds.
6. When the blade disc starts, 5 beeps are heard for 2 seconds.

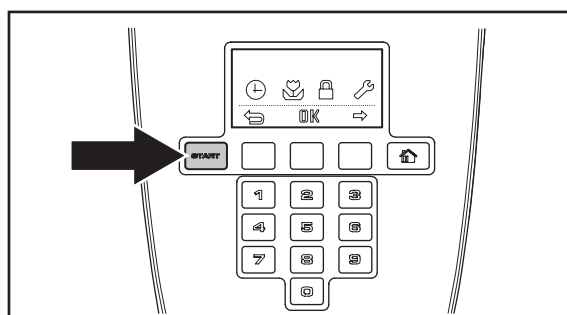

4.4 Stopping

1. Press the **STOP** button.
Automower® 305 stops, the blade motor stops and the control panel cover opens.

Restart

1. Push the Start button.
1. Shut the cover within 10 seconds. Automower® 305 starts automatically.

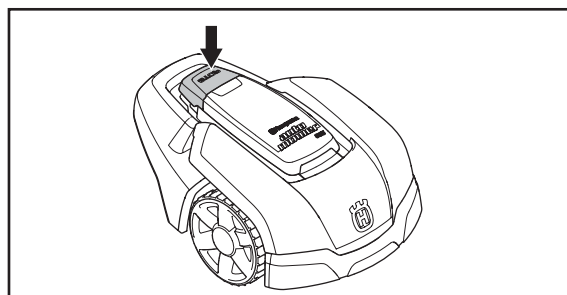

4.5 Switching off

1. Press the **STOP** button.
2. Set the main switch to the 0 position.

Always switch Automower® 305 off using the main switch if it requires maintenance or if the mower must be moved outside the working area.

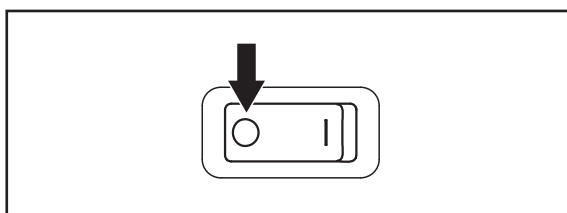

4. USE

4.6 Adjusting the cutting height

The cutting height can be varied from MIN (2 cm) to MAX (5 cm).

If the grass is long it is appropriate to let Automower® 305 start mowing at the MAX cutting height. Once the grass is shorter, you can gradually lower the cutting height.

To adjust the cutting height:

1. Press the STOP button to stop the mower and open the cover.
2. Turn the height adjustment knob to the required position. The selected position is indicated by the orange column that can be seen by the knob through the window.
 - Turn anti-clockwise to raise the cutting height.
 - Turn clockwise to lower the cutting height.

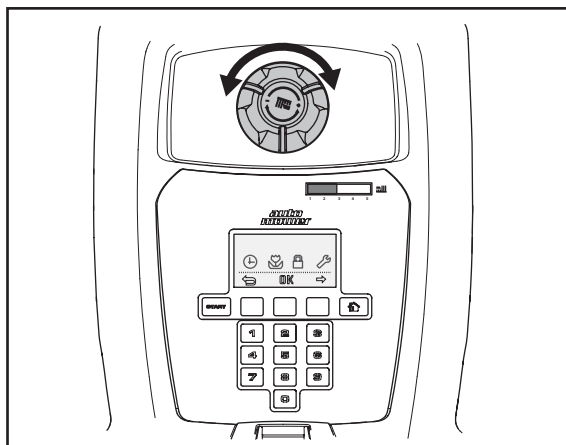

5. CONTROL PANEL

5. Control panel

All forms of commands and settings for Husqvarna Automower® 305 are made via the control panel. All functions are accessed via a number of menus.

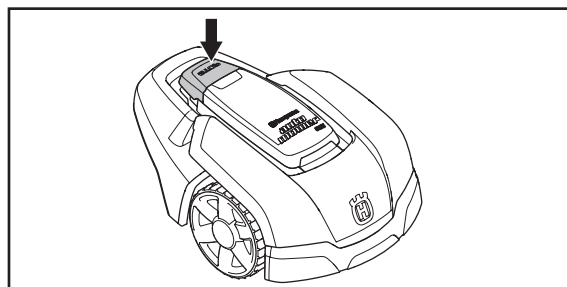

The control panel consists of a display and a keypad. All information is shown on the display and all input is done using the buttons.

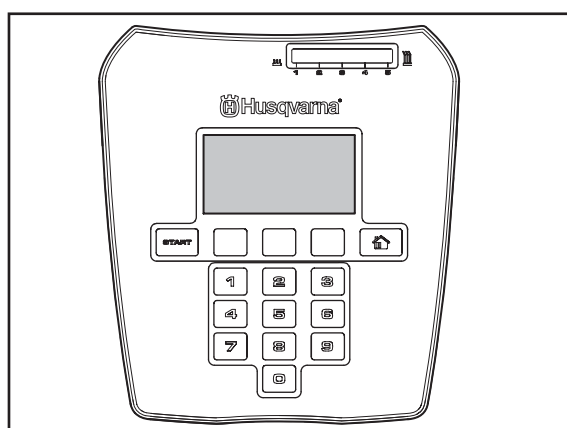

When the stop button has been pressed and the cover is opened, the operation window appears; clock, selected operating mode, number of mowing hours and battery status.

- The clock shows the current time.
- Date shows the current day.

The number of operating hours indicates the number of hours since the day of manufacture that Automower® 305 has been in operation. The time that Automower® 305 has spent mowing or looking for the charging station is counted as operating time.

- The texts *AUTO*, *MAN* or *HOME* show which mode of operation is selected.
- The battery status shows the remaining battery charge.
- The clock icon is shown when the timer is activated.
- The *MENU* text illustrates that the main menu can be reached by pressing the multi-choice button that is located under the text.

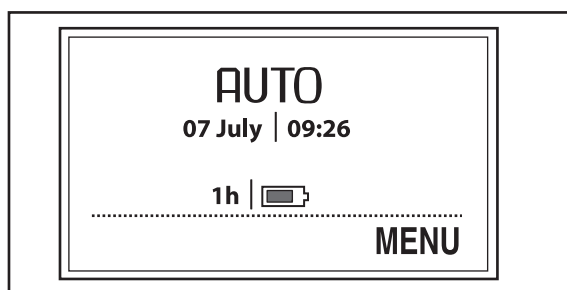

The keypad consists of four groups of buttons: operation selection button, multi-choice buttons, numbers and start button.

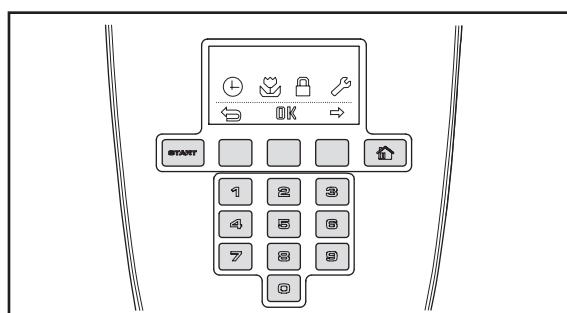

5. CONTROL PANEL

5.1 Operation selection

The operation selection button is symbolised by a house. When the button has been pressed, the selected operation mode is shown in the display. By consecutively pressing the button many times, one can choose between three different operation modes.

1. **Home:**
Sends the mower to the charging station. It remains here until another operation mode is selected. The text *Home* is shown in the operation window. When the battery is fully charged, the mower will remain parked in the charging station.
2. **Auto:**
The standard, automatic operation mode where Automower® 305 mows and charges automatically.
3. **MAN:**
If *MAN* is selected and the mower starts when it is out on the lawn, it will mow until the battery runs out. It will then stop and the '*Needs manual charging*' message will appear. The mower has to be carried back to the charging station and started manually after recharging. If *MAN* is selected and the mower starts when it is in the charging station, it will charge fully, run about 20 cm and then stop. Use the *MAN* mode when mowing secondary lawn areas, as Automower® 305 never searches for the charging station and mows until the battery runs out.

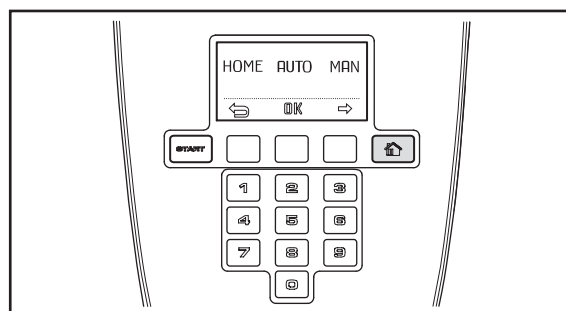

5.2 Multi-choice buttons

The three multi-choice buttons offer various functions, among others depending on where in the menu structure you are. The button function is shown at the very bottom of the display.

Example: If you are in the main menu, the left button can be used to go back, the middle button confirms any selections and the right button helps you to scroll the menu.

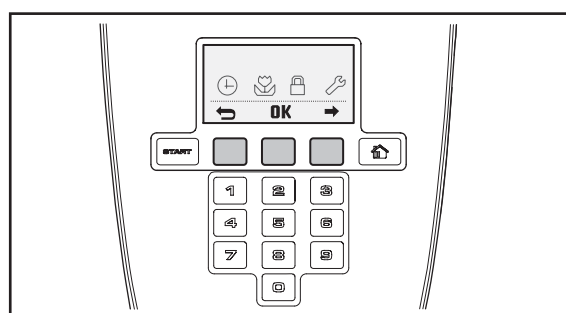

5. CONTROL PANEL

5.3 Numbers

The number keys are used for instance to enter the PIN code or time settings.

The number keys can also be used to enter a number series for shortcuts to the various menus. For more information on number series, see *6.1 Main menu*

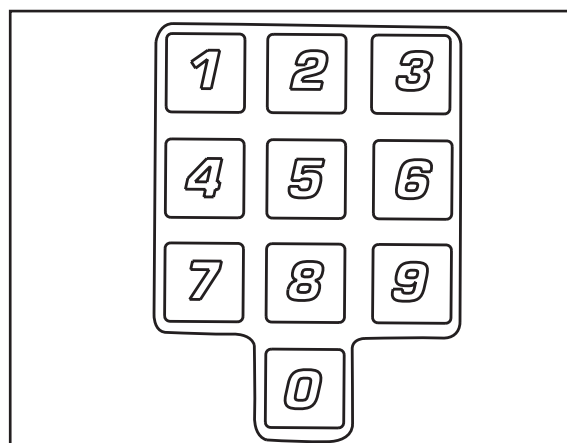

5.4 Main switch

Set the main switch in the *1* position to start Automower® 305.

Set the main switch in the *0* position when the mower is not in use or work is being carried out on the blade disc.

When the main switch is set in the *0* position the motors on the mower cannot start.

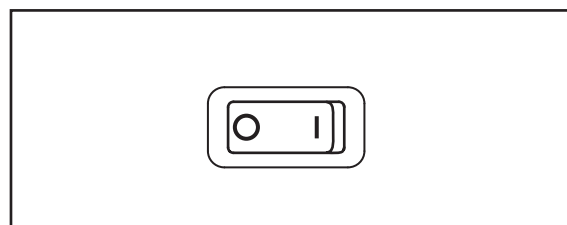

6. MENU FUNCTIONS

6. Menu functions

6.1 Main menu

The main menu consists of four options:

- *Timer (1)*
- *Installation (2)*
- *Security (3)*
- *Settings (4)*

There are a number of submenus under each option. You can access all the functions to set Automower® 305 settings via these.

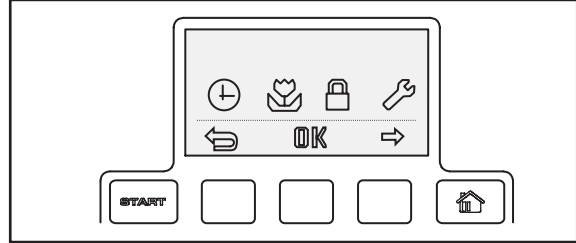

Browse between menus

Browse the main menu and submenus using the multi-choice buttons. Enter values and times using the number keys and confirm each selection with the multi-choice button marked OK. Press the multi-choice button with the **return arrow** to go up a step in the menu or keep the **Home** button pressed in for 2 seconds to go directly back to the main menu.

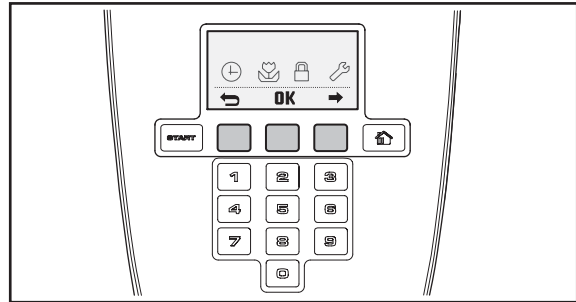

Number series

A number series can be used as a shortcut to a certain function.

The first number in the series refers to the selection in the main menu. The second number refers to the first sub-menu, etc.

For example: Press 2 1 in the main menu and the *Corridor width* submenu is shown.

The headings on the following pages include respective number series within brackets.

Submenus

Certain submenus contain options that are ticked off to the left. This means that these options are selected.

In some of the submenus there is information to the right of specific rows. This information indicates which selection has been made for the function.

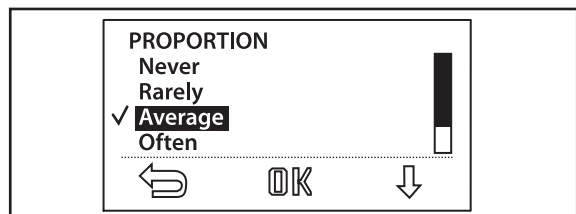

6. MENU FUNCTIONS

6.2 Menu structure

Automower® 305 Menu structure

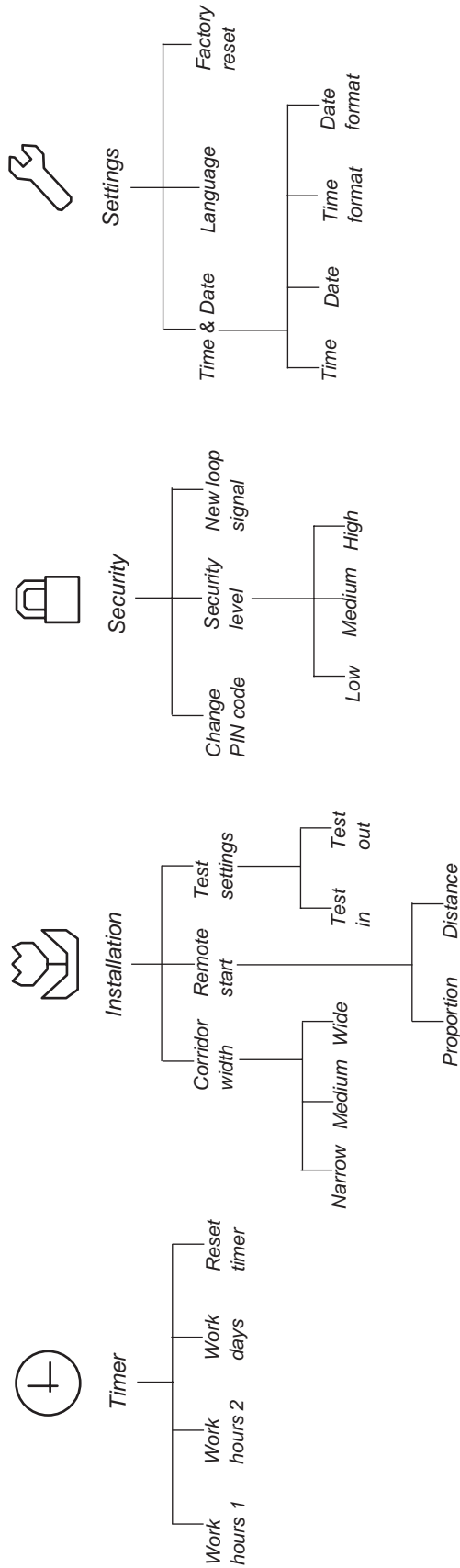

6. MENU FUNCTIONS

6.3 Timer (1)

The lawn should not be cut too often to obtain the best mowing result. Consequently, it is important to limit the operating time using the timer function if the working area is less than the mower's working capacity. When Automower® 305 is allowed to mow too much, the lawn may appear flattened. Besides, the mower is subjected to unnecessary wear.

The timer function is also an ideal means to control during which periods Automower® 305 should not mow, for example, when the children are playing in the garden.

When setting the timer, calculate that the Automower® 305 mows about 20 m² per hour and day.

- **Work hours 1 (2-1)**
to set start and stop times for operating period 1. Enter each required time in hours and minutes and press **OK** to confirm the entered time.
- **Work hours 2 (2-2)**
to set start and stop times for operating period 2. Enter each required time in hours and minutes and press **OK** to confirm the entered time.
Bypass timer (2-1)
- **Work days (2-3)**
to select the days the mower must work. Automower® 305 will work during the days that are ticked off.
- **Reset timer (2-4)**
to close all timers and reset values to the factory settings.

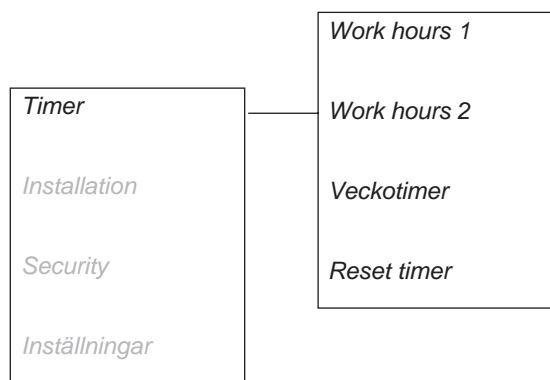

6.4 Installation (2)

The following operating settings are available via this selection in the main menu.

- **Corridor width (2-1)**
to select the distance from the guide wire the mower is allowed to travel when it follows this to and from the charging station.
- **Remote start (2-2)**
to control the mower so that it can easier reach remote parts of the garden.
- **Test settings (2-3)**
to check the above settings.

For examples of garden settings, see 7. *Garden example*

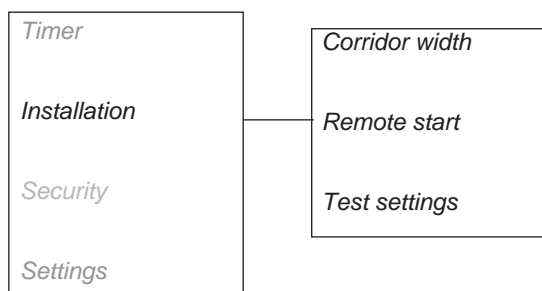

6. MENU FUNCTIONS

Corridor width (2-1)

The corridor width is a measure of how far from the guide wire the mower is allowed to travel when it follows this to and from the charging station. The area beside the wire which the mower then uses is called the Corridor.

Automower® 305 has a default setting for medium wide corridors. To further reduce the risk of tracks forming, it is recommended to select a wide corridor in working areas where it is possible to do so.

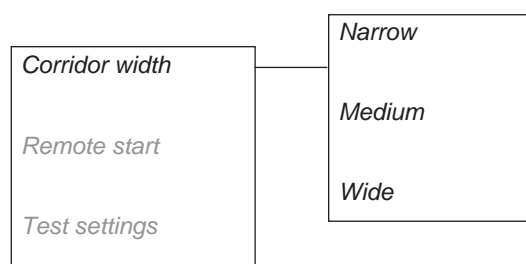

IMPORTANT INFORMATION

Always use as wide a corridor as possible. The Narrow setting must only be used when none of the other settings can be used in the working area in question.

Wide (2-1-1)

In a wide corridor, Automower® 305 mows at various distances to the guide wire.

A garden that is open and free of narrow passages should have a wide corridor to minimise the risk of tracks forming.

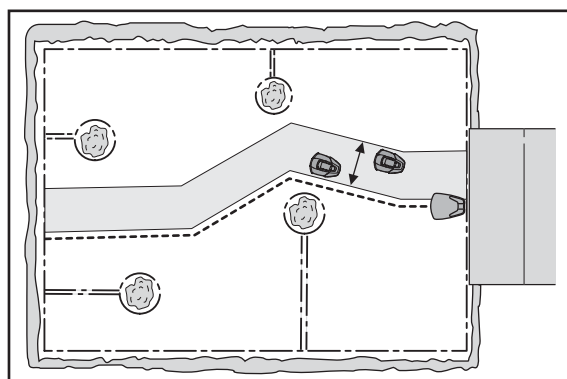

Medium (2-1-2)

In a medium wide corridor, Automower® 305 travels close to and far away from the guide wire, but not as far away from the guide wire as is the case when a wide corridor is selected.

The medium corridor setting should be selected for a garden with obstacles close to the guide wire and/or passages that do not allow for a wide corridor.

Narrow (2-1-3)

With a narrow corridor, Automower® 305 runs straight over the guide wire.

The Narrow corridor setting is not normally recommended, but in a garden with one or many narrow passages, a narrow corridor may be the only option. The Narrow corridor setting increases the risk for tracks forming along the guide wire.

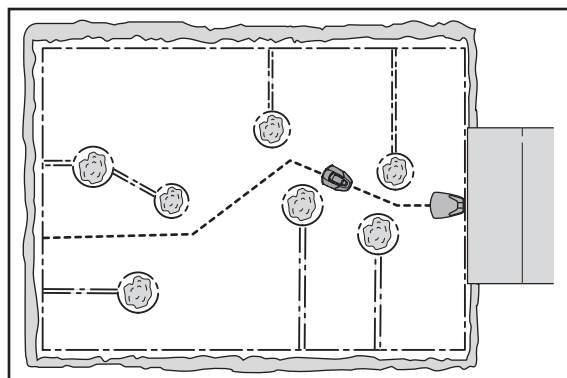

IMPORTANT INFORMATION

The distance the mower maintains from the guide wire varies depending on the layout of the working area. Use the *Test IN (2-3-1)* function to ensure that the wide corridor setting can be used in the garden in question.

6. MENU FUNCTIONS

Remote start (2-2)

The functions in this submenu are for situations where the mower has to be controlled to reach remote areas. This function is very useful in gardens where, for instance, the front and back are joined by a narrow passage where the charging station cannot be installed.

With this function activated, Automower® 305 will follow the guide wire from the charging station to the designated area. It begins to mow when it reaches this area.

- **Proportion (2-2-1)**
Enter how often of all the times Automower® 305 leaves the charging station that it has to follow the guide wire to travel to the remote area.

The following five options can be selected;

- Never (0 %)
- Rarely (approx. 20 %)
- Average (approx. 50 %)
- Often (approx. 80 %)
- Always (100 %)

At all other times, the mower leaves the charging station in the standard manner.

- **Distance (2-2-2)**
Enter the distance in metres from the charging station along the guide wire to the remote area where the mower begins mowing.
Tip! Use the *Test OUT* (2-3-2) function to determine how far it is to the remote area. The distance, stated in metres, will be shown in the mower display.

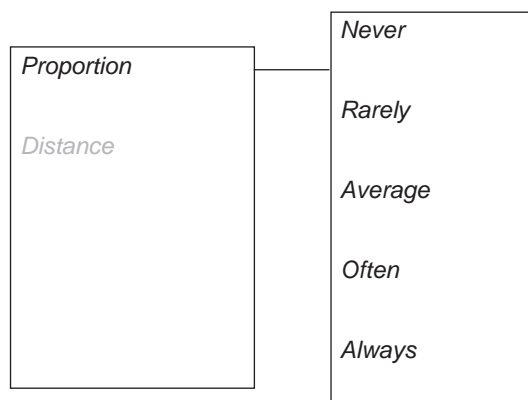

Test settings (2-3)

In the *Test settings* menu, it is possible to test settings for *Remote start (2-2)* and that the selected corridor width works for the garden in question.

Test IN (2-3-1)

The *Test IN (2-3-1)* function is used to test how Automower® 305 finds its way into the charging station.

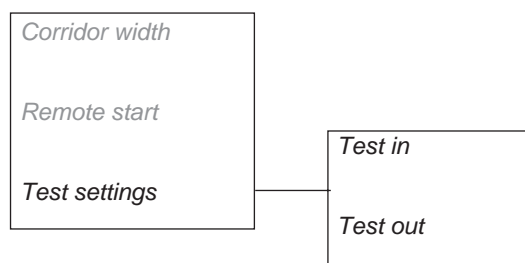

6. MENU FUNCTIONS

Selecting this function causes the mower to travel directly along the guide wire. If there is a passage that the mower cannot get through, the settings in *Corridor width (2-1)* ought to be changed from Wide to Medium. If required, the setting can also be changed to Narrow. The Narrow corridor width setting should only be used if none of the other settings work for this installation. When the *Test IN* function is activated, the mower travels the farthest distance from the wire allowed by the selected corridor width.

The figure here shows how Automower® 305 travels through a passage when *Corridor width* is set to Medium and not to Wide.

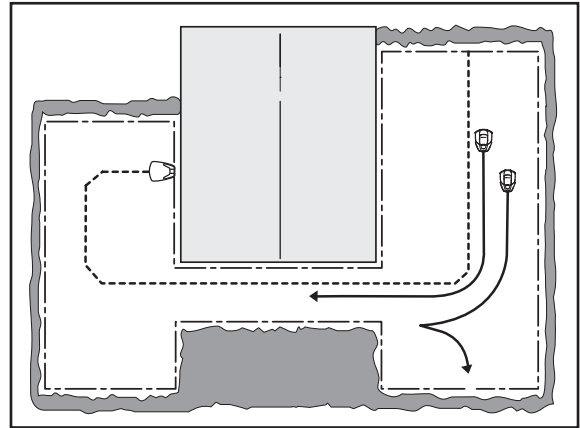

Test OUT (2-3-2)

The *Test OUT (2-3-2)* function is used to test exit settings and to calculate the distance from the charging station to a remote area.

To test the settings for *Remote start (2-2)*:

Park Automower® 305 in the charging station and select *Test OUT (2-3-2)*. The mower will then leave the charging station straight away along the guide wire and begin mowing after the designated distance.

To find out the distance from the charging station to a remote area:

State a distance that easily exceeds the true distance. The maximum distance that can be stated is 500 metres. Place Automower® 305 in the charging station and select *Test OUT (2-3-2)*. The mower will immediately leave the charging station. The distance will be shown on the display, stated in metres, as the mower runs. Stop the mower at the required position and note the distance. Enter the number of metres shown in Distance for the area in question.

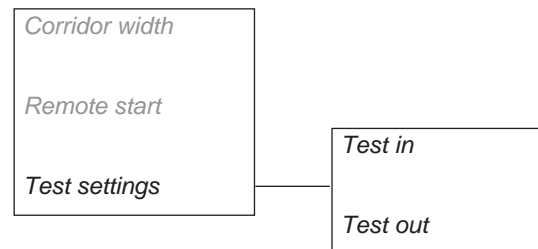

6.5 Security (3)

Through this selection, settings relating to security and the connection between the mower and the charging station can be made.

Change PIN code (3-1)

Enter the new PIN code and press **OK**. Enter the same code again and confirm by pressing **OK**. When the PIN code is changed, a message stating that the PIN code has been changed appears in the display momentarily.

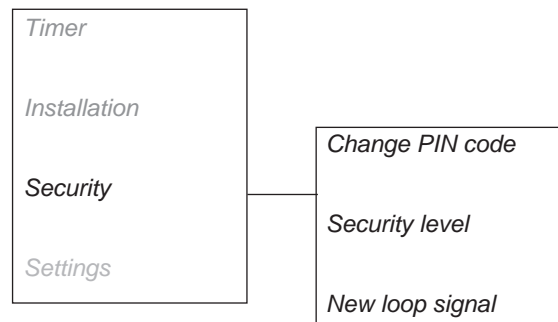

6. MENU FUNCTIONS

Security levels (3-2)

There are three security levels to choose from: low, medium and high. Low and medium security prohibits access to Automower® 305 if the PIN code is unknown. High security also includes a warning that sounds if the correct PIN code is not entered after a designated time period.

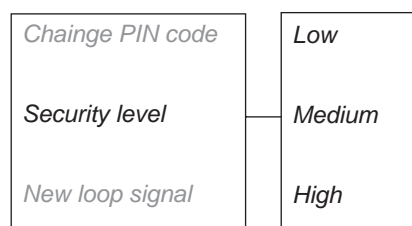

Function	Low	Medium	High
Time lock	X	X	X
PIN request		X	X
Alarm			X

IMPORTANT INFORMATION

We recommend using the High security level at all times.

- *Time lock*

This function entails that Automower® 305 cannot be started after 30 days without first entering the correct PIN code. When the 30 days has passed Automower® 305 will continue to mow as normal, but the *Enter PIN code* message appears when the cover is opened. Enter your code again and press **OK**.

- *PIN request*

This function means that Automower® 305 requests a PIN code when the main switch is set to 1 and when the STOP button has been pressed. The correct PIN code must be entered to use Automower® 305.

- *Alarm*

This function means that the PIN code must be entered within 10 seconds after the **STOP** button has been pressed or the mower has been lifted up for any reason. The alarm sounds if the correct PIN code has not been entered after three attempts. The alarm can be turned off at any time by entering the correct PIN code.

New loop signal (3-3)

The loop signal is randomly selected to create a unique link between the mower and the charging station. In rare cases, there may be a need to generate a new signal, for instance if two adjacent installations have a very similar signal.

- Park the mower in the charging station.
- Select *New loop signal* in the menu and press **OK**.

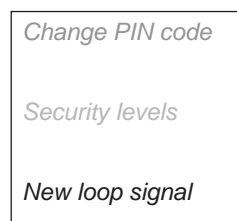

6. MENU FUNCTIONS

6.6 Settings (4)

The following operating settings are available via this selection in the main menu.

- *Time & Date (4-1)*
to set the current time and date, and the required time and date format.
- *Language (4-2)*
to select which language is to be used in the menus.
- *Factory reset (4-3)*
to reset the mower to the settings it had when it left the factory.

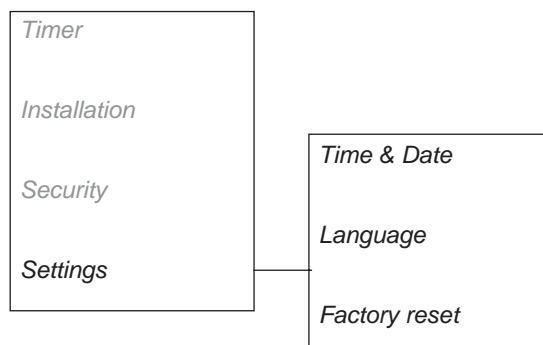

Time & Date (4-1)

- This function allows you to set current time and required time format in Automower® 305.
- *Time (4-2-1)*
Enter the correct time and press OK to exit.
- *Time format (4-2-2)*
Place the cursor at the required time format: 12h
24h Press OK to exit.
- *Date (4-3-1)*
Enter correct date and press OK to exit.
- *Date format (4-3-2)*
Place the cursor at the required date:
YYYY-MM-DD (year-month-day)
MM-DD-YYYY (month-day-year)
DD-MM-YYYY (day-month-year).
Press OK to exit.

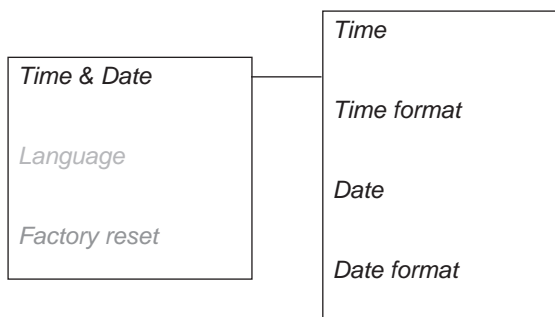

Language (4-2)

Set language with this function.

To select language: Place the cursor at Language and press **OK**. Place the cursor at the required language and press **OK**.

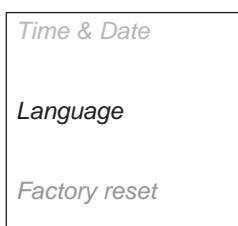

Factory reset (4-3)

This function allows you to reset Automower® 305 to the default settings it had when it left the factory.

Select Factory reset in the menu and press **OK**. Enter the correct PIN code and press **OK**.

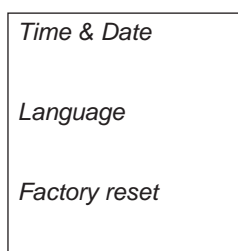

7. GARDEN EXAMPLE

7. Garden example

- Proposed installation and settings

The mower's behaviour is controlled to a certain extent by what settings are made. Adapting the mower's garden settings according to the shape of the garden makes it easier for Husqvarna Automower® 305 to frequently reach all parts of the garden and in doing so achieve a perfect mowing result.

Different gardens require different settings. The following pages outline a number of examples of gardens with installation and setting proposals.

For more detailed information about the various settings, see chapter 6. *Menu functions*.

IMPORTANT INFORMATION

The default setting for Automower® 305 has been chosen to work on as many different gardens as possible. The settings only need to be adjusted when special installation conditions exist, for example, narrow passages.

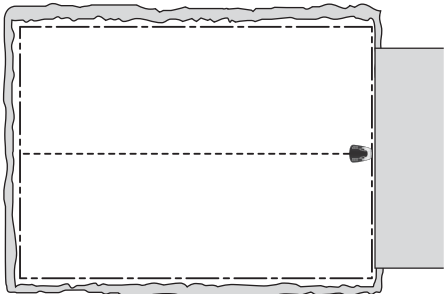
Proposals for installation and settings	
<p>Area: 150m². Open area.</p> <p><i>Timer:</i> Operating time of 8 hours per day.</p> <p><i>Corridor width:</i> Wide</p>	 <p>The diagram shows a rectangular garden area outlined with a dashed line. A horizontal dashed line runs across the middle of the garden, representing a wide corridor. On the right side of the garden, there is a grey rectangular shape representing a building or obstacle. A small black dot is located on the horizontal dashed line, near the right edge of the garden area.</p>

7. GARDEN EXAMPLE

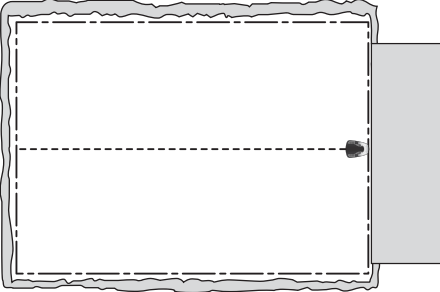
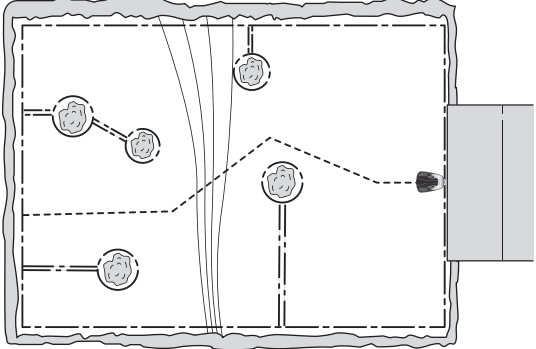
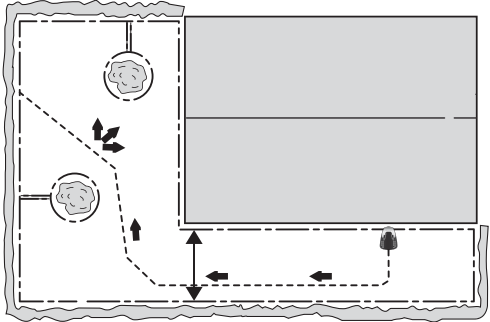
Proposals for installation and settings	
<p>Area: 500m². Open area.</p> <p><i>Timer:</i> Operating time of 24 hours per day. <i>Corridor width:</i> Wide.</p>	 <p>The diagram shows a rectangular garden layout. A dashed line indicates a wide corridor that runs horizontally across the middle of the garden. A charging station, represented by a small black circle, is located on the right side of the garden, connected to the corridor. A grey rectangular area on the right side of the garden represents a building or wall.</p>
<p>Area: 500m². A number of islands and a 25% slope along the boundary loop.</p> <p><i>Timer:</i> Operating time of 24 hours per day. <i>Corridor width:</i> Wide.</p>	 <p>The diagram shows a rectangular garden layout with several circular islands. A dashed line indicates a wide corridor that winds through the garden, connecting the islands. A charging station is located on the right side of the garden. A grey rectangular area on the right side of the garden represents a building or wall. A vertical line with a wavy pattern indicates a 25% slope along the boundary loop.</p>
<p>Area: 200m². L-shaped garden with charging station installed in the narrow area. Contains a couple of islands.</p> <p><i>Timer:</i> Operating time of 10 hours per day. <i>Corridor width:</i> Wide.</p>	 <p>The diagram shows an L-shaped garden layout. A dashed line indicates a wide corridor that follows the inner edge of the L-shape. A charging station is located in the narrow area of the L-shape. Two circular islands are located in the wider part of the L-shape. A grey rectangular area on the right side of the garden represents a building or wall. A dimension line indicates a width of 3 m/10ft for the narrow area.</p>

7. GARDEN EXAMPLE

Proposals for installation and settings

Area: 250m². U-shaped garden with the charging station placed on one of the large open areas. A guide wire should be laid in the passage.

Timer: Operating time of 12 hours per day.

Corridor width: Narrow.

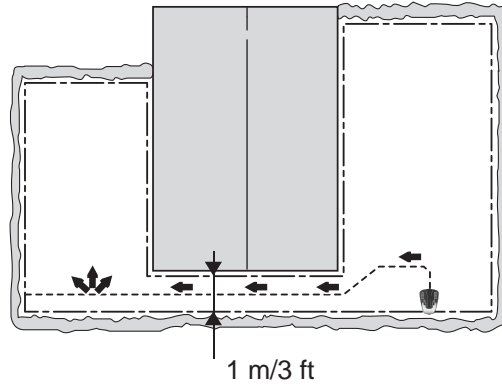

Area: 150m². There are several islands.

Timer: Operating time of 8 hours per day.

Corridor width: Medium.

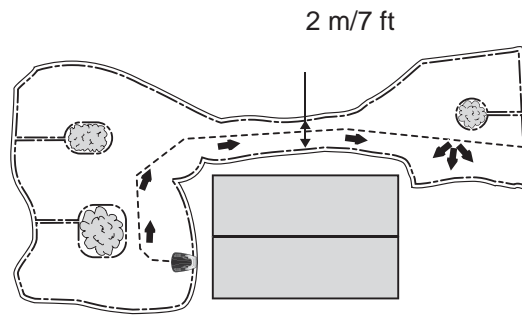

8. MAINTENANCE

8. Maintenance

Check and clean Husqvarna Automower® 305 regularly and replace worn parts if necessary to improve operating reliability and to ensure a longer service life. See *8.5 Cleaning* for more details on cleaning.

When Automower® 305 is first used, the blade disc and blades should be inspected once a week. If the amount of wear during this period has been low, the inspection interval can be increased.

It is important that the blade disc rotates easily. The edges of the blades should not be damaged. The product life of the blades varies immensely and depends for instance on:

- Operating time and size of the working area.
- Type of grass.
- Type of soil.
- The presence of objects such as cones, windfalls, toys, tools, stones, roots and the like.

The normal life is 2 to 4 months when used in areas more than 300 m² in size and longer for smaller areas. See *8.8 Replacing the blades* for how to replace the blades.

IMPORTANT INFORMATION

Working with dull blades gives a poorer mowing result. The edges of the grass are not cut clean and more energy is needed resulting in Automower® 305 not mowing such a large area.

8.1 Battery

The battery is maintenance-free, but has a limited life span of 2 - 4 years.

Battery life is dependent on the length of the season and how many hours per day Automower® 305 is used. A long season or many hours of use per day, means that the battery must be replaced more regularly.

IMPORTANT INFORMATION

Charge the battery fully at the end of the season before winter storage.

8. MAINTENANCE

8.2 Winter storage

Automower® 305

Automower® 305 must be cleaned carefully before putting it away for the winter, see 8.5 *Cleaning*.

Charge the battery fully before winter storage. Then set the main switch to 0.

Store the mower upright in a dry area free from frost, preferably in the mower's original packaging.

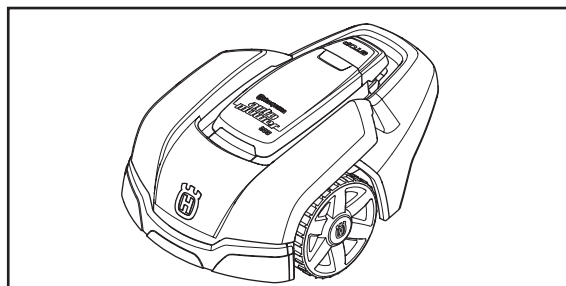

Charging station

Store the charging station and transformer indoors. The boundary wire can be left in the ground. The ends of the boundary wire should be protected from damp by putting them in a container with grease for instance.

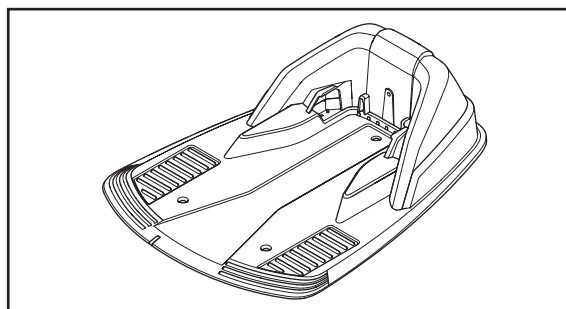

8.3 Service

Leave your Automower® 305 to a dealer for service prior to winter storage. This is essential in order to keep the mower in a good condition.

- Service usually includes the following:
- Thorough cleaning of the body, the chassis, the blade disc and all other moving parts.
- Testing of the mower's function and components.
- Checking and if required replacement of wear items such as blades and bearings.
- Testing of the mower's battery capacity as well as a recommendation of change if necessary.
- If necessary the dealer can also load Automower® 305 with new software, possibly including newly added features.

8.4 After winter storage

During a service the dealer can clean the mower thoroughly, test its function and components as well as replace wear parts if necessary. If the charging or contact strips appear to be burnt, clean them using fine grade emery cloth. Check that the mower's time and date are correct.

8.5 Cleaning

It is important to keep Automower® 305 clean. A mower with large amounts of grass stuck to it will not cope as well with slopes. It is recommended to clean using a brush and a spray with water.

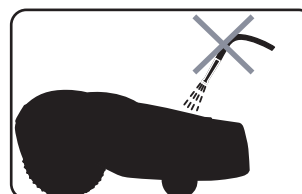

IMPORTANT INFORMATION

Never use a high-pressure washer or even running water to clean Automower® 305. Solvent must never be used when cleaning.

8. MAINTENANCE

Underframe and blade disc

1. Set the main switch to the 0 position.
2. Wear protective gloves.
3. Lift Automower® 305 onto its side.

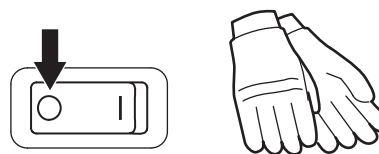

4. Clean the blade disc and underframe using, e.g. a dish-brush.

At the same time, check that the blade disc rotates freely in relation to the motor support, directly above. Check also that the skid plate rotates freely in relation to the blade disc.

If long blades of grass or other objects find their way in, these may impede the blade disc. Even a slight braking effect leads to a higher consumption of energy and longer mowing times, and at the worst will prevent the mower from being able to mow a large lawn. The blade disc must be removed to carry out a more thorough cleaning. If necessary, contact your dealer.

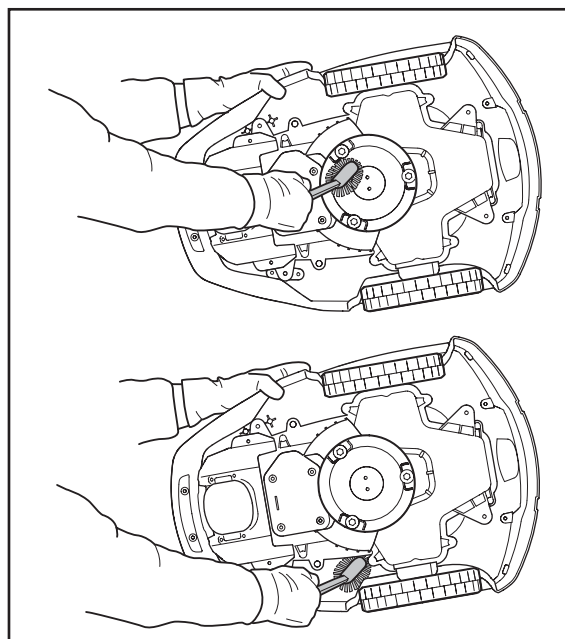

Chassis

Clean the underside of the chassis. Brush or wipe with a damp cloth.

Wheels

Clean around the front wheels and rear wheel as well as the rear wheel support unit.

Body

Use a damp, soft sponge or cloth to clean the body. If the body is very dirty it may be necessary to use a soap solution or washing-up liquid.

8.6 Transport and removal

Secure the machine during transport. It is important that Automower® 305 does not move when it is being transported, for instance, between lawns.

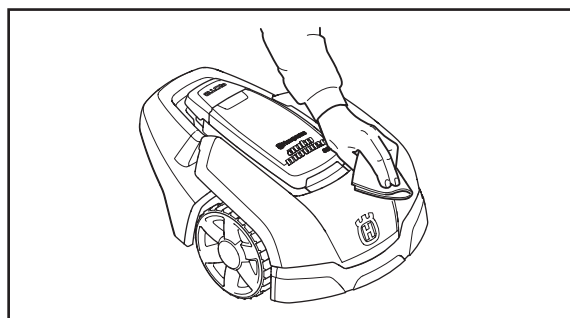

8.7 In the case of thunderstorms

To reduce the risk of damage to components in Automower® 305, we recommend that all connections to the charging station are disconnected (power supply, boundary wire and guide wire) if there is a risk of a thunderstorm.

8. MAINTENANCE

8.8 Replacing the blades



WARNING

Always use original blades and screws when replacing. Only replacing the blades and reusing the screw can result in the screw wearing during mowing and shearing off. The blades can then be thrown out and cause serious injury.

There are three blades on Automower® 305, which are screwed into the blade disc. All three blades and screws must be replaced at the same time to obtain a balanced mowing system.

There are several different types of mower blades to choose from as accessories, with different features. Use Husqvarna AB approved blades only. Please contact your dealer for more information.

To replace the blades:

1. Set the main switch to the 0 position.
2. Wear protective gloves.
3. Turn Automower® 305 upside down.
4. Remove the screw. Use a straight slot or cross-tip screwdriver.
5. Remove the blade and the screw.
6. Screw on the new blade and the new screw.

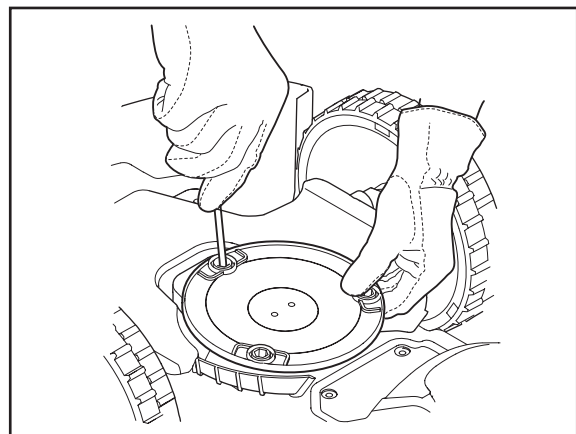
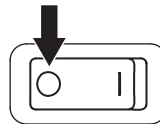

9. TROUBLE SHOOTING

9. Trouble shooting

9.1 Messages

Below we have listed a number of messages which may be shown in the display of the Husqvarna Automower® 305. If the same message appears often: contact your dealer.

Message	Cause	Action
<i>Left wheel motor blocked</i>	Grass or other object has wrapped around the drive wheel.	Check the drive wheel and remove the grass or other object.
<i>Right wheel motor blocked</i>	Grass or other object has wrapped around the drive wheel.	Check the drive wheel and remove the grass or other object.
<i>Blade disc blocked</i>	Grass or other object has wrapped around the blade disc.	Check the blade disc and remove the grass or other object.
	The blade disc lies in a pool of water.	Move the mower and if possible prevent the collection of water in the working area.
<i>No loop signal</i>	The transformer is not connected.	Check the wall socket connection and whether the miniature circuit-breaker has tripped. Check that the low voltage cable is connected to the charging station.
	Boundary wire broken.	Check the LED signals on the charging station, see Checking the installation. Repair the broken cable using an original waterproof coupler.
	The boundary wire is laid in the wrong direction around an island.	Check that the boundary wire has been laid according to the instructions in chapter 3 <i>Installation</i> .
	The connection between Automower® 305 and the charging station has been lost.	Park Automower® 305 in the charging station and generate a new loop signal via Security -> New loop signal (3-3).
	Disturbances from metal objects (fences, reinforcement steel) or buried cables close by.	Try moving the boundary wire.
<i>Trapped</i>	Automower® 305 has got caught in something.	Free Automower® 305 and rectify the reason for it getting trapped.
	Automower® 305 gets stuck behind a number of obstacles.	Check if there are any obstacles which make it hard for Automower® 305 to move on from this place.

9. TROUBLE SHOOTING

Message	Cause	Action
<i>Outside working area</i>	The boundary wire connections to the charging station are crossed.	Check that the boundary wire is connected correctly.
	The boundary wire is too close to the edge of the working area.	Check that the boundary wire has been laid according to the instructions in chapter 3 <i>Installation</i> .
	The working area slopes too much.	Check that the boundary wire has been laid according to the instructions in chapter 3 <i>Installation</i> .
	The boundary wire has been routed the wrong way around an island.	Check that the boundary wire has been laid according to the instructions in chapter 3 <i>Installation</i> .
	Disturbances from metal objects (fences, reinforcement steel) or buried cables close by.	Try moving the boundary wire.
	The mower finds it hard to distinguish the signal from an Automower® 305 installation close by.	Park A in the charging station and generate a new loop signal via <i>Security -> New loop signal (3-3)</i> .
<i>Low battery voltage</i>	Automower® 305 cannot find the charging station.	Alter the search settings according to the Corridor width (2 -1) function, see 6.4 <i>Installation (2)</i> . Change the position of the charging station and/or the guide wire.
	The battery is spent.	Expected life is 2 - 4 years. Contact your dealer to replace the battery.
<i>Wrong PIN code</i>	Wrong PIN code has been entered. Three attempts are permitted, the keypad is then blocked for five minutes.	Enter the correct PIN code.
<i>No drive</i>	Automower® 305 has got caught in something.	Free the mower and rectify the reason for the lack of drive. If it is due to wet grass, wait until the lawn has dried before using the mower.
<i>Charging station blocked</i>	The contact between the charging strips and contact strips may be poor and Automower® 305 has made a number of charging attempts.	Place Automower® 305 in the charging station and check that the charging strips and contact strips make good contact.
	An object is obstructing Automower® 305.	Remove the object.
<i>Stuck in charging station</i>	There is an object in the way of Automower® 305 preventing it from leaving the charging station.	Remove the object.
<i>Upside down</i>	Automower® 305 leans too much or has turned over.	Turn the mower the right way up.
<i>Needs manual charging</i>	Automower® 305 is set in <i>MAN</i> operating mode.	Park the mower in the charging station. This behaviour is normal; no action required.

9. TROUBLE SHOOTING

9.2 Symptom

If your Automower® 305 does not work as expected, follow the troubleshooting guide below. If you still cannot find the reason for the fault, contact your dealer.

Symptom	Cause	Action
Uneven mowing results	Automower® 305 works too few hours per day.	Increase the mowing time, see 6.3 <i>Timer (1)</i> .
	Working area too large.	Try limiting the working area or extending the working time, see 6.3 <i>Timer (1)</i> .
	Dull blades.	Replace all the blades and screws so that the rotating parts are balanced.
	Long grass in relation to the set cutting height.	Increase the cutting height and then successively lower.
	Accumulation of grass by the blade disc or around the motor shaft.	Check that the blade disc rotates freely and easily. If not, screw off the blade disc and remove grass and foreign objects. See 8.5 <i>Cleaning</i>
Automower® 305 runs at the wrong time	The clock on Automower® 305 needs to be set.	Set the clock, see 6.6 <i>Settings (4)</i> .
	The start and stop times for mowing are incorrect.	Reset the start time and stop time settings for mowing, see 6.3 <i>Timer (1)</i> .
Automower® 305 vibrates	Unbalanced blade disc or damaged blades.	Inspect the blades and screws and replace them if necessary.
Automower® 305 moves but the blade disc does not rotate	Automower® 305 is looking for the charging station.	No action. The blade disc does not rotate when the mower is searching for the charging station.
The mower mows for shorter periods than usual between charges	Grass or other foreign object blocks the blade disc.	Remove and clean the blade disc.
Both the mowing and charging times are shorter than usual	This behaviour is normal at low temperatures (gradual increase below 15 °C).	No action.
Automower® 305 starts mowing immediately outside the charging station instead of using <i>Remote start (2-2)</i>		Change corridor width.

10. TECHNICAL DATA

10. Technical data

Data	Automower® 305
Dimensions	
Length	55 cm
Width	39 cm
Height	25 cm
Weight	7 kg
Electrical system	
Battery	Specialised Lithium-Ion battery, 18 V/1.6 Ah
Transformer	230V / 24V
Mean energy consumption at maximum use	9 kWh/month with a working area of 500 m ²
Noise emissions	
Measured noise level	66 dB(A)
Guaranteed noise level	68 dB(A)
Mowing	
Mowing system	Three, pivoted cutting knife blades
Blade motor speed	3200 rpm
Power consumption during cutting	20 W +/- 20 %
Cutting height	2-5 cm
Cutting width	17 cm
Working capacity	500 m ² +/- 20%

Husqvarna AB does not guarantee full compatibility between the Automower® 305 and other types of wireless systems such as remote controls, radio transmitters, buried electric animal fencing or similar.

11. Environmental information

The symbol on Husqvarna Automower® 305 or its packaging indicates that this product may not be treated as household waste. It should instead be left at a suitable recycling centre to recycle its electronic components and batteries. Contact your dealer for a disassembly of the batteries.

By ensuring this product is disposed of correctly, you will help prevent potential negative consequences for the environment and human health, which could otherwise be caused by inappropriate waste handling of this product.

For more detailed information about recycling of this product, please contact your local council office, your household waste disposal service or the shop where you purchased the product.

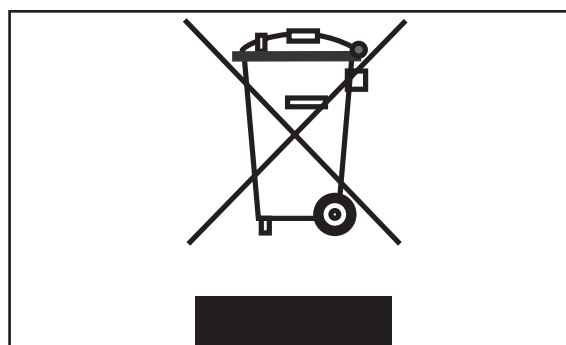

12. EU DECLARATION OF CONFORMITY

12. EU declaration of conformity

EU Declaration of Conformity (only applies to Europe)

Husqvarna AB, SE-561 82 Huskvarna, Sweden, hereby declares that robotic lawnmower **Husqvarna Automower® 305** from 2011's serial numbers and onwards (the year is clearly stated in plain text on the rating plate with subsequent serial number), complies with the requirements of the COUNCIL'S DIRECTIVE:

- Directive "relating to machinery" **2006/42/EC**.
- Directive "relating to electromagnetic compatibility" **2004/108/EC** and applicable supplements. The following standards have been applied:
 - **EN 61000-6-3** (emission)
 - **EN 61000-6-2** and **EN 61000-6-1** (immunity)

Huskvarna, October 1, 2010



Christer Gustavsson, Development Manager robotic lawnmowers
(Authorized representative for Husqvarna AB and responsible for technical documentation)

ORIGINAL INSTRUCTIONS

AUTOMOWER® is a trademark owned by Husqvarna AB. Copyright © 2011 HUSQVARNA. All rights reserved.