

Kustom[®]



OWNER'S MANUAL

BASS AMPLIFIER

P/N 006-0048-00

KUSTOM WARRANTY

All Kustom amplifiers, power units, mixers, and their associated components and parts, except as specified below, are guaranteed, by Kustom Electronics, Inc., to the original purchaser to be free of defects in material or workmanship for a period of five (5) years from the date of purchase.

— and —

All Kustom speaker cabinets and their associated components and parts, except as specified below, are guaranteed, by Kustom Electronics, Inc., to the original purchaser to be free of any defects in materials and workmanship for a period of one (1) year from the date of purchase.

— provided —

- (1) The original purchaser applies for a Kustom Warranty Card for the guaranteed product(s) within 10 days of the date of purchase; and,
- (2) Within the applicable period of this guarantee, the original purchaser delivers, at his own expense, the defective product(s) to an Authorized Kustom Dealer or Service Center for repair; or, where no such dealer or service center is nearby, obtains at his own expense from Kustom Electronics, Inc., an "Authorization Number" to return merchandise and ships, at his own expense, the defective product(s) to Kustom Electronics Customer Service, 909 W. Cherry, Chanute, Kansas 66720. The repaired product(s) will be returned freight prepaid.

Kustom Electronics, Inc., will, at its option, repair or replace the defective part(s) or product(s).

Excluded from coverage by this warranty are exterior surfaces and finishes, face panels, grill cloth, covers, knobs, handles, casters and appearance items.

Any modification of the Kustom-manufactured product(s) such as the installation of substitute parts, rewiring or other changes to the system without written authorization from Kustom Electronics, Inc., will automatically void this warranty.

Kustom Electronics, Inc., shall not be liable for any direct, special, incidental or consequential damages incurred by reason of a breach of the above provisions, except as expressly provided above.

The provisions of this warranty shall be covered by the local laws of the state where the original purchaser shall purchase products covered hereby, and shall be enforceable only to the extent, and in the manner, permitted under such laws.

EXCEPT AS HEREIN EXPRESSLY PROVIDED, KUSTOM ELECTRONICS, INC., MAKES NO WARRANTY, EXPRESSED OR IMPLIED, OF MERCHANTABILITY, FITNESS FOR A PARTICULAR PURPOSE, OR OTHERWISE.

Your new Kustom Amplification System has been designed with your needs in mind.

Through extensive research, Kustom amplifiers have been engineered and constructed with the finest material and components available.

A wide variety of highly technical requirements and specifications, which each piece of equipment must comply with, has been incorporated to give your Kustom amplifier maximum performance and dependability.

On the following pages are operating instructions and technical specifications to better help you create YOUR sound.

KUSTOM III BASS

CHANNEL NO. 1-BASS

CHANNEL NO. 2-NORMAL

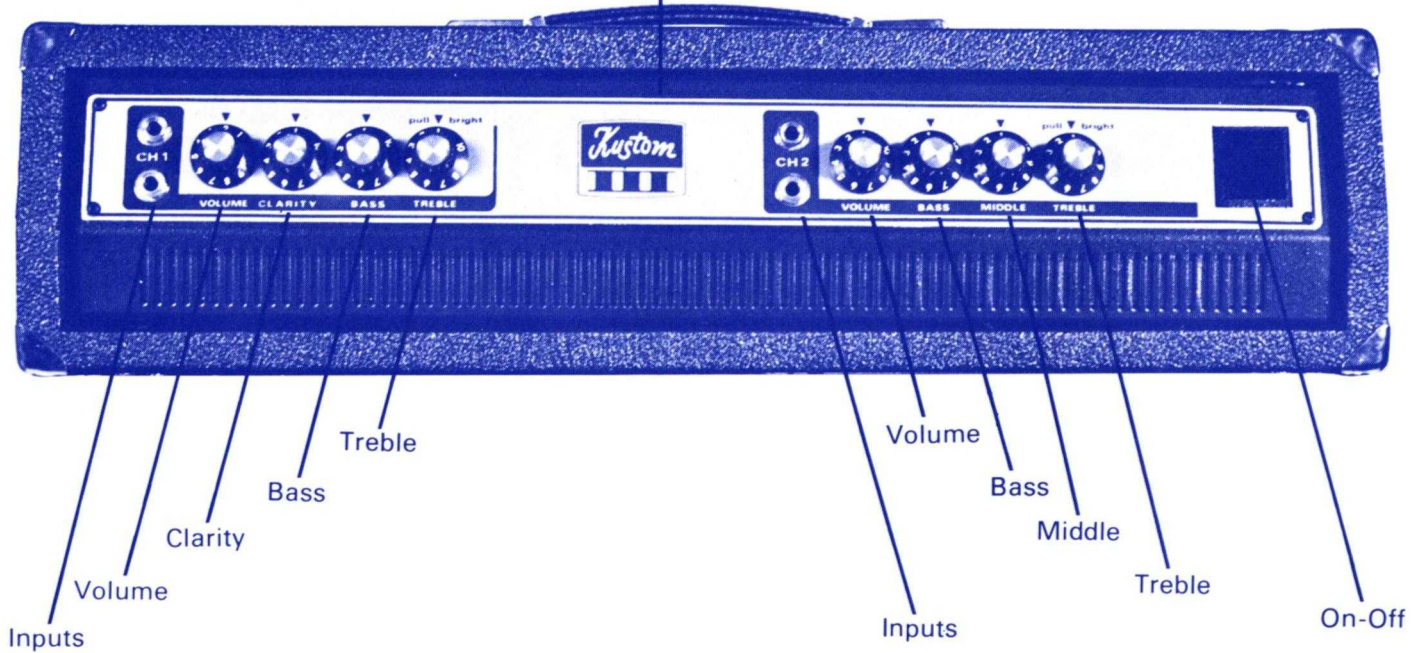

TONE CONTROL OPERATION

CHANNEL I – BASS

As a general rule, the amount of control (boost or cut), any one of the tone controls has will be greatly influenced by the type of bass guitar and pick-up combinations used. The electric bass guitar has a fundamental frequency range of from approximately 42Hz (open low E) to approximately 200Hz (12th fret of 4th string). The dominant harmonic overtones occur in the frequency range from about 160Hz to 700Hz. The relationship between the fundamental and these harmonics determine the tonal quality of the amplified sound. Tone controls allow the musician to control this relationship.

The tone controls can only control the frequencies within their operating range. As an example, if the musician is using an electric bass guitar with two pickups, and he is using the top pickup (the one closest to the fret board) and playing with his fingers, the treble control will exhibit very little control action. This is due to the fundamental frequencies being the predominant components. There are very few harmonic overtones generated when a bass is played in this manner, and therefore, there are very few harmonics within the control range of the treble control. On the other hand, if the musician is playing using the bottom pickup and using a pick, the treble control will exhibit a great deal of control action. This is due to a larger quantity of harmonic overtones in relation to the fundamental frequency.

The Bass control will always exhibit a noticeable degree of boost and cut with almost any type of playing style or pickup configuration. This is due to the simple fact that you cannot have harmonic overtones without a fundamental and the bass control action is centered in the fundamental frequency range.

The clarity control determines the level of the lowest fundamental frequencies produced by the electric bass guitar. The word clarity was chosen because more low fundamental frequencies present cause a deeper and sometimes muddy sound. By use of the clarity control the depth of sound can be adjusted for almost any type of music or playing environment. This control is especially useful in adjusting the amplified sound for different sizes and shapes of rooms or clubs.

CHANNEL II -- NORMAL

As previously stated, the amount of control (boost or cut), any one of the tone controls has is greatly influenced by the type of guitar, strings, playing style and pickup configuration. Channel II is designed to allow a bass guitarist a modified tone control action and also to allow for proper equalization when using a standard electric guitar. A brief explanation of this channel's action when using an electric guitar follows:

The electric guitar has a frequency range of from approximately 74Hz (open low E) to 1320Hz (12th fret high E). The dominant harmonic overtones occur in the frequency range from about 128Hz to 5280Hz.

The relationship between the fundamental and these harmonics determine the tonal quality of the amplified sound. The tone control circuitry provides the musician with the means to control the relationships between these frequencies.

The tone control circuits for the electric guitar are configured very much like those used on the older tube-type amplifier. This arrangement has the advantages of unique boost and cut points and the disadvantage that if all controls are adjusted to minimum, no output signal results.

The tone control circuits used for Channel II are of the boost and cut type and like those used in the bass channel, can only control the frequencies within their operating range. It will be noticed, however, that when using an electric guitar, control action will be more apparent under most operating conditions than for the electric bass. This is due to the ability of the guitar to play chords. The strumming of an electric guitar produces an extremely complex signal which in most instances has a fundamental and at least one harmonic overtone in one of the tone control operating ranges.

OPERATING CONTROLS

CHANNEL I -- BASS

- Volume** Adjusts the loudness of the amplifier. It should be noted that, depending on the instrument used, maximum amplifier output can be obtained at almost any control setting. The control numbers are provided for ease in readjusting the amplifier to a specific output.
- Clarity** Controls the level of very low bass frequencies. By adjustment of this control, the relationship of the fundamental frequencies to the higher harmonies may be controlled. This control is of the boost and cut type.
- Bass** Adjusts the level of the "low end" or bass frequencies in relation to the "high end" or treble frequencies. This control is of the boost and cut type to allow the musician maximum control over his sound.
- Treble** This control adjusts the level of the treble frequencies in relation to the bass frequencies. This control is also of the boost and cut type.
- Bright** Located on the treble control, the bright switch provides an additional degree of bite or boost to the treble frequencies.

CHANNEL II -- NORMAL

- Volume** Operates the same as Channel I volume control.
- Bass** The Channel II bass control operates the same as Channel I, except that the points at which boost and cut occur are modified to resemble those of older tube-type amplifiers.
- Middle** The Channel II middle control is of the boost and cut type which allows control over the frequencies located in the middle of the electric guitar range. The control action operates the same as the older tube-type amplifier.
- Treble** The Channel II treble control is of the boost and cut type. The action of this control also resembles that of a tube-type amplifier.
- Bright** Operates the same as Channel I Bright Control.

TECHNICAL SPECIFICATIONS

Preamplifier gain measured at 1.0KHz. Tone controls maximum.

Channel I 32 db
Channel II 39 db

Signal-to-noise ratio

Channel I Gain min. - 81 db
Gain max. - 58 db
Channel II Gain min. - 81 db
Gain max. - 50 db

Minimum input voltage required for rated output. Tone controls adjusted for flat response at 1.0KHz. Volume adjusted maximum.

Channel I 50mv RMS
Channel II 22mv RMS

Power output measured into a 3.0 ohm load at 1.0KHz. All tone controls maximum with bright switch in.

250 Watts peak (125 Watts RMS) @ .65% distortion.
260 Watts peak (130 Watts RMS) @ 1.0% distortion.
312 Watts peak (156 Watts RMS) @ 5.0% distortion.
336 Watts peak (168 Watts RMS) @ 10% distortion.

Frequency response measured with tone controls adjusted for flat response.	± 3.0 db	72Hz - 20KHz
Nominal input impedance	Channel I	50.0K ohms
	Channel II	220K ohms
Line output at rated power	0.700V RMS, $Z_L = 600$ ohms	
Absolute minimum speaker load impedance	6.0 ohms	
AC accessory receptacle maximum load	200 Watts	

TONE CONTROL RANGE

CHANNEL I

Clarity	± 8.0 db @ 50.0Hz
Bass	± 12.0 db @ 60.0Hz
Treble	± 15.0 db @ 6.0KHz

CHANNEL II

Bass	± 7.0 db @ 40.0Hz
Treble	± 9.0 db @ 15.0KHz
Middle	± 6.0 db @ 350.0Hz

SPEAKER WIRING DIAGRAM

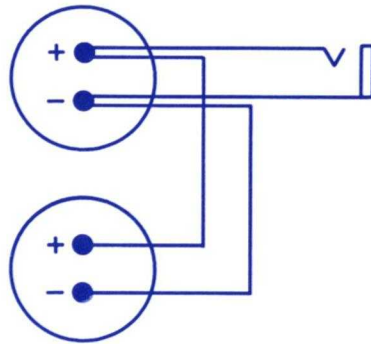



KUSTOM ELECTRONICS, INC.
1010 WEST CHESTNUT, CHANUTE, KANSAS 66720

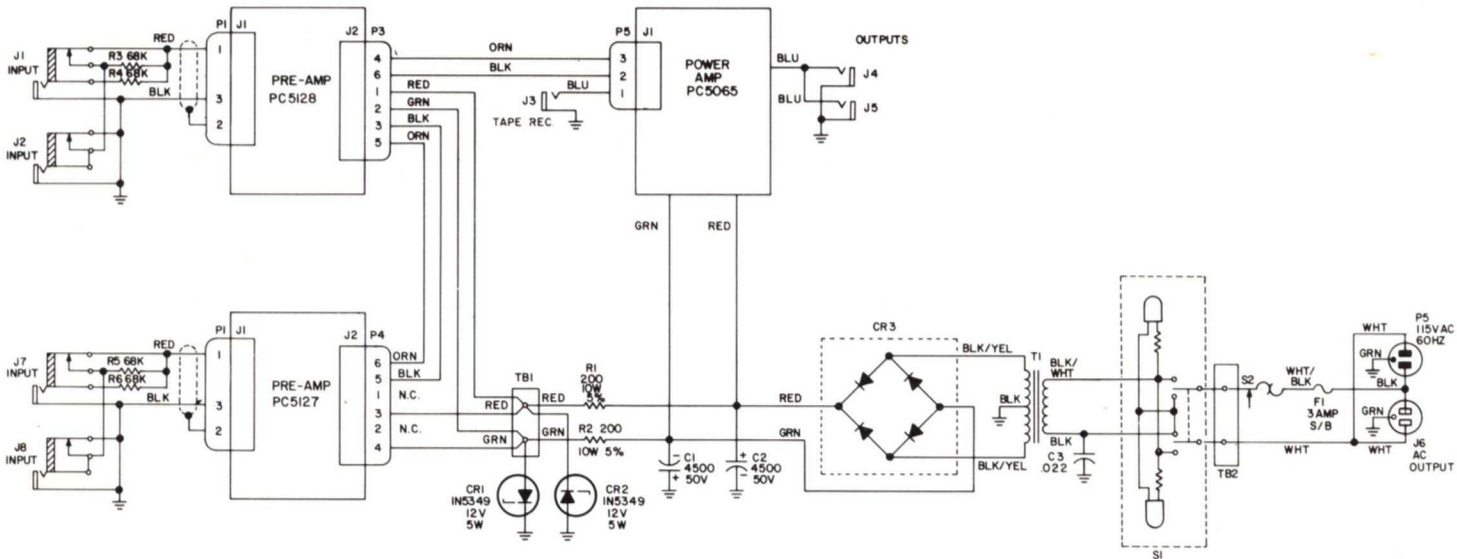

SYMBOL	KUSTOM PART NO.
J1, J2, J7, J8	030-1006-00
J3, J4, J5	030-1001-00
J6	030-2066-00
P1, P2, P5	030-2033-00
P3, P4	030-2033-01
P6	090-0149-00
CR1, CR2	007-5349-00
CR3	007-6018-00
T1	019-7017-00
S1	031-0059-00
F1	036-0000-05
S2	036-0001-00
TB1	090-0093-00
C1, C2	095-0044-01
C3	106-0000-02
R1, R2	136-0000-15
TB2	090-0072-00

HIGHEST REF NOS	REF NOS NOT USED
J8	
P6	
CR3	
T1	
F1	
S2	
TB2	
R6	
C3	

REV. 0		MOD. DATE		BY		DATE		SCALE		SHT. OF		ELECTRONICS, INC. CHANUTE, KANSAS 66720	
1	11/89	1/87	1/87	CMJ		DATE	4-73	TOLERANCES	NONE	MATERIAL	NONE	NAME	
2	1/85	1/85	1/85	CMJ		DATE	1/87	INTERCONNECT DIAGRAM		KUSTOM III BASS			
SCALE		NONE		PART NUMBER		002-0107-00							

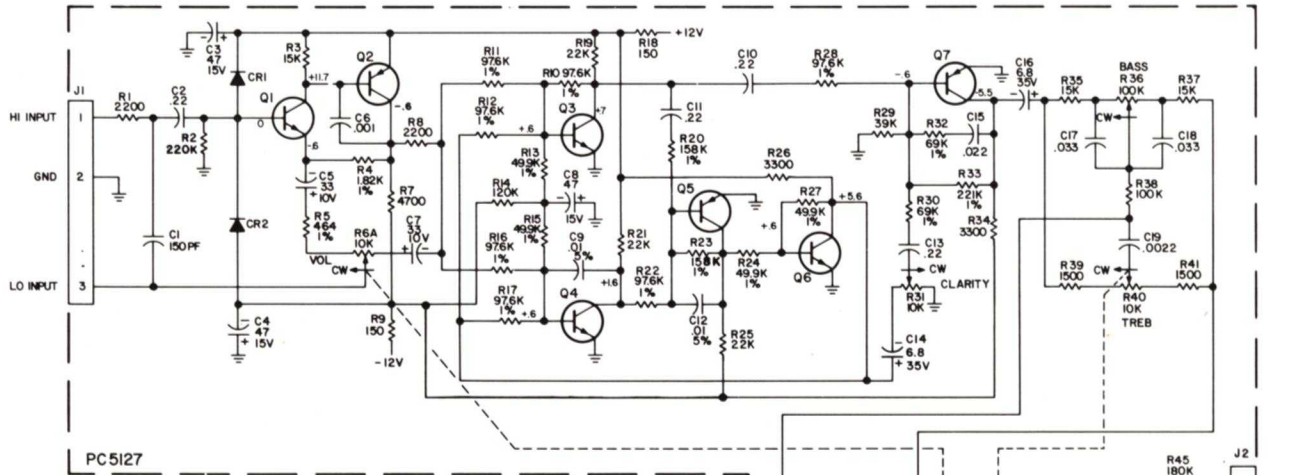

SYMBOL	KUSTOM PART NO	HIGHEST REF NOS	REF NOS NOT USED
Q1,Q3,Q4,Q6	007-0008-00	Q7	
Q2,Q5,Q7	007-0009-00	CR2	
CR1,CR2	007-6016-00	I'	
I1	007-7015-00	J2	
J1	030-2034-00	C29	
J2	030-2035-00	R47	
C3,C4,C8	096-1007-10		
C5,C7	096-1007-09		
C14,C16	096-1007-29		
R4	125-1821-01		
R5	125-4640-01		
R6	133-0053-00		
R10,R11,R12,R16 R17,R22,R28	125-9762-01		
R13,R15,R24,R27	125-4992-01		
R20,R23	125-1583-01		
R30,R32	125-6902-01		
R31	133-0022-00		
R33	125-2213-01		
R36	133-0021-00		
R40/SI	133-0036-00		

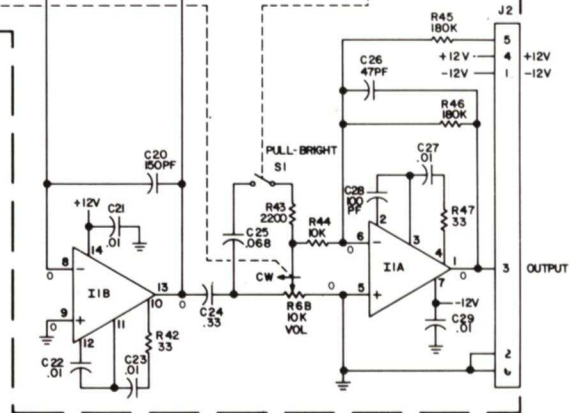

REV. NO.		DATE		TOLERANCES	MATERIAL
1	1/192	7-73		NONE	NONE
DRAWN		DATE		ELECTRONICS, INC.	
Harryman		4-73		CHANDLER, KANSAS 64780	
CHECKED		DATE		NAME	
[Signature]		7-73		SCHEMATIC DIAGRAM	
PART NO.		REV.		PRE-AMP PC 5127	
NONE		OF 1		PART NUMBER	
				002-5127-00	

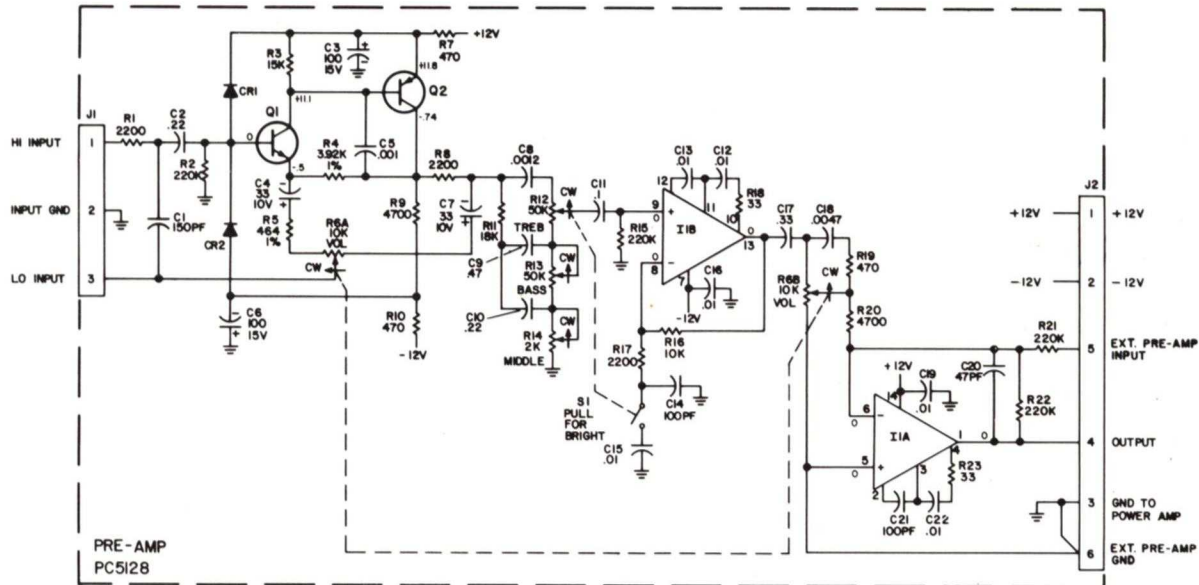

NOTES:

1. ALL RESISTORS ARE 1/2W, 10%, UNLESS NOTED.
2. ALL CAPACITOR VALUES ARE IN MICROFARADS, UNLESS NOTED.
3. VOLTAGE MEASUREMENTS ARE WITH POWER ON, NO SIGNAL, NO LOAD, AND MEASURED FROM COMMON GROUND.

HIGHEST REF NOS	REF NOS NOT USED	SYMBOL	KUSTOM PART NO.
C22		CR1, CR2	007-606-00
CR2		Q1	007-0008-00
I1		Q2	007-0009-00
J2		J1	030-2034-00
Q2		J2	030-2035-00
R23		R6	133-0053-00
		R12, R51	133-0035-00
		R13	133-0034-00
		R14	133-0033-00
		I1	007-7015-00

REV	DATE	BY	DESCRIPTION
1	4-2-73	W	SPRITS
2	4-2-73	W	REVISED
3	4-2-73	W	REVISED
4	4-2-73	W	REVISED
5	4-2-73	W	REVISED
6	4-2-73	W	REVISED
7	4-2-73	W	REVISED
8	4-2-73	W	REVISED
9	4-2-73	W	REVISED
10	4-2-73	W	REVISED
11	4-2-73	W	REVISED
12	4-2-73	W	REVISED
13	4-2-73	W	REVISED
14	4-2-73	W	REVISED
15	4-2-73	W	REVISED
16	4-2-73	W	REVISED
17	4-2-73	W	REVISED
18	4-2-73	W	REVISED
19	4-2-73	W	REVISED
20	4-2-73	W	REVISED
21	4-2-73	W	REVISED
22	4-2-73	W	REVISED
23	4-2-73	W	REVISED
24	4-2-73	W	REVISED
25	4-2-73	W	REVISED
26	4-2-73	W	REVISED
27	4-2-73	W	REVISED
28	4-2-73	W	REVISED
29	4-2-73	W	REVISED
30	4-2-73	W	REVISED
31	4-2-73	W	REVISED
32	4-2-73	W	REVISED
33	4-2-73	W	REVISED
34	4-2-73	W	REVISED
35	4-2-73	W	REVISED
36	4-2-73	W	REVISED
37	4-2-73	W	REVISED
38	4-2-73	W	REVISED
39	4-2-73	W	REVISED
40	4-2-73	W	REVISED
41	4-2-73	W	REVISED
42	4-2-73	W	REVISED
43	4-2-73	W	REVISED
44	4-2-73	W	REVISED
45	4-2-73	W	REVISED
46	4-2-73	W	REVISED
47	4-2-73	W	REVISED
48	4-2-73	W	REVISED
49	4-2-73	W	REVISED
50	4-2-73	W	REVISED
51	4-2-73	W	REVISED
52	4-2-73	W	REVISED
53	4-2-73	W	REVISED
54	4-2-73	W	REVISED
55	4-2-73	W	REVISED
56	4-2-73	W	REVISED
57	4-2-73	W	REVISED
58	4-2-73	W	REVISED
59	4-2-73	W	REVISED
60	4-2-73	W	REVISED
61	4-2-73	W	REVISED
62	4-2-73	W	REVISED
63	4-2-73	W	REVISED
64	4-2-73	W	REVISED
65	4-2-73	W	REVISED
66	4-2-73	W	REVISED
67	4-2-73	W	REVISED
68	4-2-73	W	REVISED
69	4-2-73	W	REVISED
70	4-2-73	W	REVISED
71	4-2-73	W	REVISED
72	4-2-73	W	REVISED
73	4-2-73	W	REVISED
74	4-2-73	W	REVISED
75	4-2-73	W	REVISED
76	4-2-73	W	REVISED
77	4-2-73	W	REVISED
78	4-2-73	W	REVISED
79	4-2-73	W	REVISED
80	4-2-73	W	REVISED
81	4-2-73	W	REVISED
82	4-2-73	W	REVISED
83	4-2-73	W	REVISED
84	4-2-73	W	REVISED
85	4-2-73	W	REVISED
86	4-2-73	W	REVISED
87	4-2-73	W	REVISED
88	4-2-73	W	REVISED
89	4-2-73	W	REVISED
90	4-2-73	W	REVISED
91	4-2-73	W	REVISED
92	4-2-73	W	REVISED
93	4-2-73	W	REVISED
94	4-2-73	W	REVISED
95	4-2-73	W	REVISED
96	4-2-73	W	REVISED
97	4-2-73	W	REVISED
98	4-2-73	W	REVISED
99	4-2-73	W	REVISED
100	4-2-73	W	REVISED

Kustom ELECTRONICS, INC.
CHAMUTI, KANSAS 64739

REV	DATE	BY	DESCRIPTION
1	4-2-73	W	SPRITS
2	4-2-73	W	REVISED
3	4-2-73	W	REVISED
4	4-2-73	W	REVISED
5	4-2-73	W	REVISED
6	4-2-73	W	REVISED
7	4-2-73	W	REVISED
8	4-2-73	W	REVISED
9	4-2-73	W	REVISED
10	4-2-73	W	REVISED
11	4-2-73	W	REVISED
12	4-2-73	W	REVISED
13	4-2-73	W	REVISED
14	4-2-73	W	REVISED
15	4-2-73	W	REVISED
16	4-2-73	W	REVISED
17	4-2-73	W	REVISED
18	4-2-73	W	REVISED
19	4-2-73	W	REVISED
20	4-2-73	W	REVISED
21	4-2-73	W	REVISED
22	4-2-73	W	REVISED
23	4-2-73	W	REVISED
24	4-2-73	W	REVISED
25	4-2-73	W	REVISED
26	4-2-73	W	REVISED
27	4-2-73	W	REVISED
28	4-2-73	W	REVISED
29	4-2-73	W	REVISED
30	4-2-73	W	REVISED
31	4-2-73	W	REVISED
32	4-2-73	W	REVISED
33	4-2-73	W	REVISED
34	4-2-73	W	REVISED
35	4-2-73	W	REVISED
36	4-2-73	W	REVISED
37	4-2-73	W	REVISED
38	4-2-73	W	REVISED
39	4-2-73	W	REVISED
40	4-2-73	W	REVISED
41	4-2-73	W	REVISED
42	4-2-73	W	REVISED
43	4-2-73	W	REVISED
44	4-2-73	W	REVISED
45	4-2-73	W	REVISED
46	4-2-73	W	REVISED
47	4-2-73	W	REVISED
48	4-2-73	W	REVISED
49	4-2-73	W	REVISED
50	4-2-73	W	REVISED
51	4-2-73	W	REVISED
52	4-2-73	W	REVISED
53	4-2-73	W	REVISED
54	4-2-73	W	REVISED
55	4-2-73	W	REVISED
56	4-2-73	W	REVISED
57	4-2-73	W	REVISED
58	4-2-73	W	REVISED
59	4-2-73	W	REVISED
60	4-2-73	W	REVISED
61	4-2-73	W	REVISED
62	4-2-73	W	REVISED
63	4-2-73	W	REVISED
64	4-2-73	W	REVISED
65	4-2-73	W	REVISED
66	4-2-73	W	REVISED
67	4-2-73	W	REVISED
68	4-2-73	W	REVISED
69	4-2-73	W	REVISED
70	4-2-73	W	REVISED
71	4-2-73	W	REVISED
72	4-2-73	W	REVISED
73	4-2-73	W	REVISED
74	4-2-73	W	REVISED
75	4-2-73	W	REVISED
76	4-2-73	W	REVISED
77	4-2-73	W	REVISED
78	4-2-73	W	REVISED
79	4-2-73	W	REVISED
80	4-2-73	W	REVISED
81	4-2-73	W	REVISED
82	4-2-73	W	REVISED
83	4-2-73	W	REVISED
84	4-2-73	W	REVISED
85	4-2-73	W	REVISED
86	4-2-73	W	REVISED
87	4-2-73	W	REVISED
88	4-2-73	W	REVISED
89	4-2-73	W	REVISED
90	4-2-73	W	REVISED
91	4-2-73	W	REVISED
92	4-2-73	W	REVISED
93	4-2-73	W	REVISED
94	4-2-73	W	REVISED
95	4-2-73	W	REVISED
96	4-2-73	W	REVISED
97	4-2-73	W	REVISED
98	4-2-73	W	REVISED
99	4-2-73	W	REVISED
100	4-2-73	W	REVISED

