



CONNECTUPS™ WEB/SNMP CARD

User's Guide
X and BD Models

www.powerware.com

Class B EMC Statements

FCC Part 15

NOTE This equipment has been tested and found to comply with the limits for a Class B digital device, pursuant to part 15 of the FCC Rules. These limits are designed to provide reasonable protection against harmful interference in a residential installation. This equipment generates, uses and can radiate radio frequency energy and, if not installed and used in accordance with the instructions, may cause harmful interference to radio communications. However, there is no guarantee that interference will not occur in a particular installation. If this equipment does cause harmful interference to radio or television reception, which can be determined by turning the equipment off and on, the user is encouraged to try to correct the interference by one or more of the following measures:

- Reorient or relocate the receiving antenna.
- Increase the separation between the equipment and the receiver.
- Connect the equipment into an outlet on a circuit different from that to which the receiver is connected.
- Consult the dealer or an experienced radio/TV technician for help.

ICES-003

This Class B Interference Causing Equipment meets all requirements of the Canadian Interference Causing Equipment Regulations ICES-003.

Cet appareil numérique de la classe B respecte toutes les exigences du Règlement sur le matériel brouilleur du Canada.

Powerware is a registered trademark and ConnectUPS, X-Slot, BestDock, and Status@Glance are trademarks of Powerware Corporation.

Microsoft and Windows are registered trademarks of Microsoft Corporation. Netscape is a trademark of Netscape Communications Corporation. HyperTerminal is a registered trademark of Hilgraeve. Novell, and NetWare are registered trademarks of Novell, Inc. UNIX is a registered trademark of The Open Group. Linux is a registered trademark of Linus Torvalds. OpenView is a trademark of Hewlett-Packard Company. IBM is a registered trademark of International Business Machines Corporation.

© Copyright 2002 Powerware Corporation, Raleigh, NC, USA. All rights reserved. No part of this document may be reproduced in any way without the express written approval of Powerware Corporation.

Requesting a Declaration of Conformity

Units that are labeled with a CE mark comply with the following harmonized standards and EU directives:

- Harmonized Standards: EN 50091-1-1 and EN 50091-2; IEC 950 Second Edition, Amendments A1, A2, A3, and A4
- EU Directives: 73/23/EEC, Council Directive on equipment designed for use within certain voltage limits
93/68/EEC, Amending Directive 73/23/EEC
89/336/EEC, Council Directive relating to electromagnetic compatibility
92/31/EEC, Amending Directive 89/336/EEC relating to EMC

The EC Declaration of Conformity is available upon request for products with a CE mark. For copies of the EC Declaration of Conformity, contact:

Powerware Corporation
Koskelontie 13
FIN-02920 Espoo
Finland
Phone: +358-9-452 661
Fax: +358-9-452 665 68



TABLE OF CONTENTS

1 Introduction	1
System Application	3
2 Installation	5
ConnectUPS Web/SNMP Card Front Panels	6
LED Description	7
Configuration	7
Configuring the Card Locally	7
Configuring the Card Remotely	8
3 Local Configuration	9
Before You Start	9
Connecting the Card	9
Configuring the Card	11
Set the IP Address, Gateway Address and MIB System Group	14
Set Web/SNMP Card Control Group	14
Set Write Access Managers	15
Set Trap Receivers	15
Set IP Addresses of Primary and Secondary Date Server	15
UPS Event Actions	15
Set UPS Information	16
Set Superuser Name and Password	16
Email Notification	16
Set Website Links	16
Back to Main Menu	16
4 Remote Configuration	17
Add a Routing Condition in the Computer	17
Running the Web Browser	18
Setup Network Configuration	19
5 UPS Power Management	21
UPS Management from a Web Browser	21
Viewing Status@aGlance	21
ConnectUPS MultiView Software	22

Becoming a Superuser	22
Turning the UPS On and Off	23
Forcing the UPS to Shut Down	23
Planning a Scheduled UPS Shutdown and Restart	24
Configuring E-mail Notification	25
Performing a Manual UPS Battery Test	27
Viewing the UPS History Logs	27
UPS Management from an SNMP NMS	27
Viewing UPS Monitoring Parameters	28
Forcing the UPS to Shut Down	28
Receiving Event Traps	28
Automatic Shutdown of UPS-Protected Computers	29
Appendix	31
DIP Switch Description	32
Jumper 1 (JP1) Settings	32
Upgrading the Card Firmware	33
Service and Support	34
Two-Year Limited Warranty (US and Canada Only)	35
International Limited Warranty	36



CHAPTER 1

INTRODUCTION

The ConnectUPS™ Web/SNMP Card is a network card for your uninterruptible power system (UPS) that provides both SNMP and HTTP compatibility. You can install the card in any Powerware® UPS that has an X-Slot™ or a BestDock™ slot.

The ConnectUPS Web/SNMP Card is available in two models: the ConnectUPS-X for X-Slot UPSs and the ConnectUPS-BD for UPSs with a BestDock slot. Both models can connect to a twisted-pair Ethernet (10/100BaseT) network using an RJ-45 connector.

The ConnectUPS-X has a built-in switching hub that allows three additional network devices to be connected to the network without the requirement of additional network drops.

With the ConnectUPS Web/SNMP Card, you can monitor the UPS several different ways:

- using a Web browser such as Microsoft® Internet Explorer or Netscape™ to monitor and manage the connected UPS.
- using your Internet-ready cell phone or PDA (personal digital assistant).
- SNMP-compatible network management software (user-supplied) monitors the UPS in a method similar to that of other network devices.

The card also supports remote monitoring and shutdown from UPS-protected computer systems. NetWatch client software for use with a ConnectUPS Web/SNMP Card is supplied on the Powerware Software Suite CD or on the Web at www.powerware.com. Client software is available for Microsoft Windows® 95/98/Me/NT/2000/XP, Novell® NetWare® and various versions of UNIX®, including Linux®. These programs communicate through TCP/IP with the ConnectUPS Web/SNMP Card and automatically shutdown the protected system during extended power outages.

In addition, the ConnectUPS Web/SNMP Card has the following features:

- Hot-swappable feature simplifies installation by allowing you to install the card safely without powering down the critical UPS load.
- Configuration from serial port, Telnet, or HTTP Web browser.
- Management from HTTP Web browser, Internet-ready cell phone or PDA, or SNMP management software.
- E-mail notification of changes in the UPS status through SMTP (simple mail transport protocol) via e-mail client software, a PCS (personal communication services) phone, or alphanumeric pager.
- Supports Powerware (XUPS.MIB) and RFC-1628 Standard UPS (STDUPS.V1.MIB) management information bases.
- Firmware upgradable from a Microsoft Windows utility via a network connection.
- Scheduling function to control UPS shutdowns and startups.
- History log files (data and events) for recording power problems.
- UPS status information available to registered NetWatch clients for automatic shutdown of Microsoft Windows 95/98/Me/NT/2000/XP, Novell NetWare, and UNIX (including Linux).
- With a special Status@aGlance™ page, a color-coded background on your Web browser provides quick visibility of the UPS status.
- Multiple ConnectUPS Web/SNMP Cards can be monitored simply using free ConnectUPS MultiView software.

System Application

The following diagram shows how the ConnectUPS Web/SNMP Card can be used in a network application.

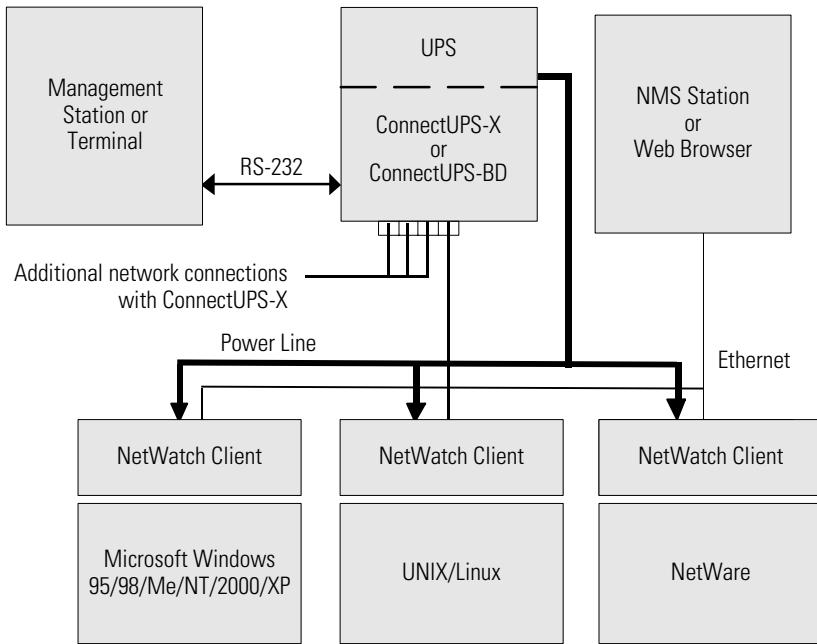

Figure 1. ConnectUPS Web/SNMP Card System Application Diagram



CHAPTER 2

INSTALLATION

With the hot-swappable feature, the ConnectUPS Web/SNMP Card can be installed easily without turning off the UPS or disconnecting the load.

To install the ConnectUPS Web/SNMP Card, perform the following steps:

1. Verify that both DIP switches on the card are set to the **0** (off) position.
2. Remove the X-Slot or BestDock cover on the UPS rear panel. Retain the screws.



NOTE If there is another card already installed with an attached communication cable, disconnect the cable and then remove the card.

3. To prevent electrostatic discharge (ESD), place one hand on a metal surface such as the UPS rear panel.

Slide the ConnectUPS Web/SNMP Card into the open slot and secure with the screws removed in Step 2.

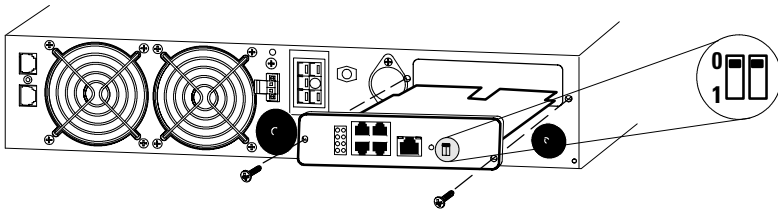

4. Connect an active 10/100BaseT cable to the Uplink Ethernet connector on the ConnectUPS-X or to the network connector on the ConnectUPS-BD.



NOTE Three additional 10/100 Mb Ethernet connectors are available on the ConnectUPS-X and are served by an internal switching hub. If you frequently move devices between these connectors or make configuration changes, it may be necessary to clear the cache by pressing the Reset button on the card front panel.

ConnectUPS Web/SNMP Card Front Panels

The card panel details are shown in Figure 2 and Figure 3.

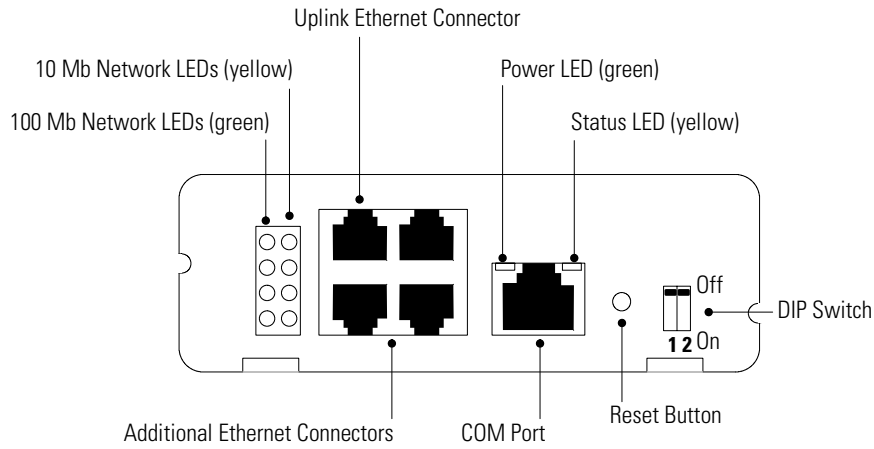

Figure 2. ConnectUPS-X Panel Details

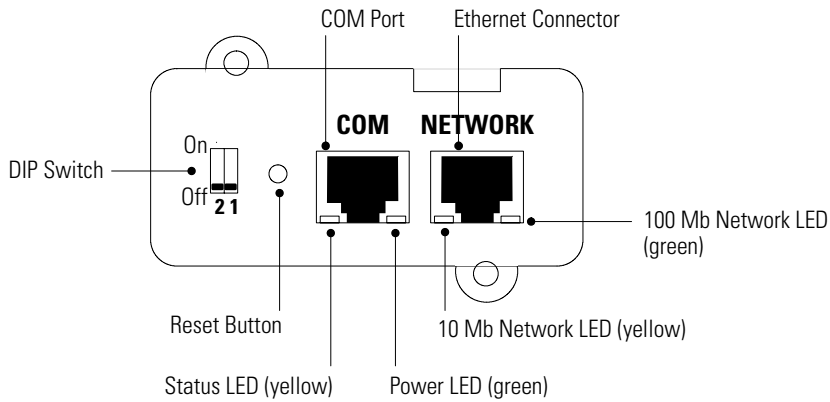

Figure 3. ConnectUPS-BD Panel Details

LED Description

The functions of the ConnectUPS Web/SNMP Card are indicated by the Status and either the 10 Mb or 100 Mb LEDs, as listed in Table 1.

Table 1. LED Definitions

Status LED	10 Mb or 100 Mb LED	Card Function Description
Flickering	On/Flickering	Normal operation with Ethernet traffic
On	On	ConnectUPS Web/SNMP Card error
Off	Off	UPS power low (no power to the ConnectUPS Web/SNMP Card)
Flashing	Flashing	No connection to UPS (alternate flashing as the ConnectUPS Web/SNMP Card restarts)

Configuration

You must configure the ConnectUPS Web/SNMP Card before you can use it. There are two ways to configure the card:

- locally through the serial communication port
- remotely using a Web browser or Telnet utility

Configuring the Card Locally

The card has a configuration program that you can access by using the supplied serial cable to connect the card to a terminal or a computer with a terminal emulation program.

If you choose to configure your card locally, see “Local Configuration” on page 9.

Configuring the Card Remotely

You can configure the card remotely through a network using a Web browser or Telnet utility.



NOTE Security-related parameters and some hardware parameters cannot be configured from a Web browser, but can be changed from the Telnet utility.

If you choose to configure your card remotely, see “Remote Configuration” on page 17.



CHAPTER 3

LOCAL CONFIGURATION

Use the following procedure to access the card's configuration program through a serial port.

Before You Start

To use the configuration program for the card, you need:

- The serial cable included with the card.
- A terminal with a serial communication port, or a computer with a terminal emulation program such as HyperTerminal®.

The serial line should be set to 9600 baud, No parity, 8 data bits, 1 stop bit, and no flow control.

Connecting the Card

To connect the card to the terminal or computer and start the configuration program:

1. Plug the serial cable into the COM port on the ConnectUPS Web/SNMP Card.
2. Plug the other end of the serial cable into the TTY port on the terminal or the COM port on your computer.

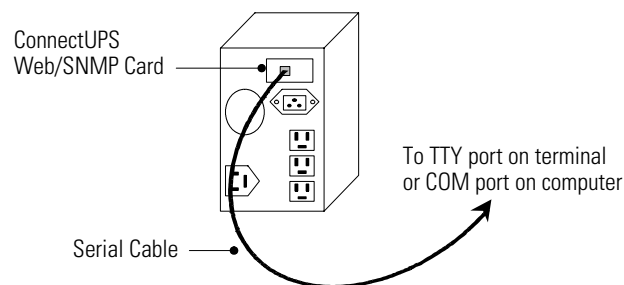

Figure 4. Cable Connection from Serial Port

3. Open your terminal emulation program such as HyperTerminal and select the appropriate serial connection (such as COM1).
The serial line should be set to 9600 baud, No parity, 8 data bits, 1 stop bit, and no flow control.
4. Verify that the UPS is turned on.
5. After a few seconds, press [Enter]. The Password screen appears (see Figure 5).
If the screen does not appear, press [Enter] again.
If you still do not see the Password screen, check the following conditions:
 - Verify the serial line is set to 9600 baud, No parity, 8 data bits, 1 stop bit, and no flow control.
 - If the serial line settings are correct, check the cabling to verify all connections are secure.
 - Verify that your terminal program is on the correct communication port for the serial connection.
 - Verify that the ConnectUPS Web/SNMP Card has power (one or more LEDs on the card should be illuminated). The UPS should be turned on.
6. Type your *password* (the default password is *admin*) and press [Enter]. The Main Menu screen appears.

```

=====
|           [ ConnectUPS Web/SNMP Card Configuration Utility ]
=====
Enter Password: *****
=====
|           [ ConnectUPS Web/SNMP Card Configuration Utility ]
=====
  1. Web/SNMP Card Settings
  2. Reset Configuration to default
  3. Restart Web/SNMP Card
  4. UPS Pass-Through
  0. Exit
Please Enter Your Choice =>_

```

Figure 5. ConnectUPS Web/SNMP Card Main Menu Screen

Configuring the Card

To configure the card:

1. Type **1** to enter the Web/SNMP Card Settings screen (see Figure 6).

```

=====
|           [ ConnectUPS Web/SNMP Card Configuration Utility ]
=====
  1. Web/SNMP Card Settings
  2. Reset Configuration to default
  3. Restart Web/SNMP Card
  4. UPS Pass-Through
  0. Exit

Please Enter Your Choice =>1

=====
|           [ ConnectUPS Web/SNMP Card Configuration Utility ]
=====
  1. Set the IP Address, Gateway Address and MIB System Group
  2. Set Web/SNMP Card Control Group
  3. Set Write Access Managers
  4. Set Trap Receivers
  5. Set IP Addresses of Primary and Secondary Date Server
  6. UPS Event Actions
  7. Set UPS Information
  8. Set Superuser Name and Password
  9. Email Notification
 10. Set Website Links
  0. Back to Main Menu

Please Enter Your Choice =>_

```

Figure 6. Web/SNMP Card Settings Screen

2. Type **1** to enter the Set the IP Address, Gateway Address and MIB System Group menu. Enter the appropriate settings for your network (see page 14).

3. Change any other options as needed for your particular configuration by typing the corresponding number shown in the menu (**2** through **10**). Each setting is described in the following sections.
4. Type **0** to return to the Main Menu.
5. Type **0** to exit the ConnectUPS Web/SNMP Card configuration. The ConnectUPS Web/SNMP Card automatically saves all settings after exiting the configuration function (see Figure 7).



NOTE The ConnectUPS Web/SNMP Card may take up to two minutes to establish communication with the UPS. Please wait before attempting communication with the card from a Web browser or network management system (NMS).

NOTE Telnet Operation – Once the card is reachable on the network, you can use a Telnet utility to adjust any of the configuration settings. The menus are identical to those seen during serial configuration and are password-protected for Superuser access only.

```
+=====
|           [ ConnectUPS Web/SNMP Card Configuration Utility ]
+=====

  1. Set the IP Address, Gateway Address and MIB System Group
  2. Set Web/SNMP Card Control Group
  3. Set Write Access Managers
  4. Set Trap Receivers
  5. Set IP Addresses of Primary and Secondary Date Server
  6. UPS Event Actions
  7. Set UPS information
  8. Set Superuser Name and Password
  9. Email Notification
 10. Set Website Links
    0. Back to Main Menu

Please Enter Your Choice =>0

+=====
|           [ ConnectUPS Web/SNMP Card Configuration Utility ]
+=====

  1. Web/SNMP Card Settings
  2. Reset Configuration to default
  3. Restart Web/SNMP Card
  4. UPS Pass-Through
  0. Exit

Please Enter Your Choice =>0
```

Figure 7. Exiting the Configuration Program

Set the IP Address, Gateway Address and MIB System Group

Use this function (option **1**) to set the IP address, the gateway address, or the management information base (MIB) parameters of the card, as listed in Table 2.

Table 2. Parameters with Examples

No.	Function	Description	Example
1	IP Address	IP address of the card	192.72.173.188
2	Gateway Address	Default IP address of the network gateway	192.72.173.254
3	Network Mask	Subnet mask setting	255.255.255.0
4	sysContact	System contact string of MIB (up to 127 characters)	Powerware
5	sysName	System name parameter for MIB (up to 127 characters)	ConnectUPS Web/SNMP Card
6	sysLocation	System location parameter for MIB (up to 127 characters)	TEST LAB

Set Web/SNMP Card Control Group

For those users who intend to use BOOTP/DHCP, Telnet, or secure HTTP in order to configure, control, update, or manage the card, certain control parameters must be enabled or disabled. Use this function to modify those parameters (option **2**).



NOTE To prevent unauthorized viewing of the Web pages presented by the ConnectUPS Web/SNMP Card, use this function to enable HTTP Security Control.

NOTE To obtain an IP address using BOOTP/DHCP (instead of serial configuration), set DIP Switch 2 on the front panel to the ON position (OFF is the default).

Set Write Access Managers

For those users who intend to use an SNMP-compatible NMS to manage the ConnectUPS Web/SNMP Card, the IP address of the management station must be added to the list on the ConnectUPS Web/SNMP Card in order to receive read (get) or write (set) access rights. Community strings may be different for read or write access. Use this function to add or delete the IP address of the management station (option **3**).

Set Trap Receivers

For those users who intend to use an SNMP-compatible NMS to manage the ConnectUPS Web/SNMP Card, the IP address of the machine intended to be the trap receiver must be added to the list on the ConnectUPS Web/SNMP Card. Use this function to add or delete the IP address of the trap receivers (option **4**). This information is accessible via the HTTP interface for easy modification after the card is on the network.

Set IP Addresses of Primary and Secondary Date Server

Use this function to set the IP addresses of the primary and secondary date servers (option **5**). This information is accessible via the HTTP interface for easy modification after the card is on the network.

Computer systems with the ConnectUPS Web/SNMP Card-compatible NetWatch client software are periodically monitored by the ConnectUPS Web/SNMP Card to maintain a consistent date and time with your network. The computers' IP address must be listed as the Primary or Secondary Date Server.

UPS Event Actions

Use this function to configure actions that the ConnectUPS Web/SNMP Card performs during AC Fail and Low Battery events (option **6**). This information is accessible via the HTTP interface for easy modification after the card is on the network.

Set UPS Information

Use this function to enter additional information about the UPS including date of installation and date of last battery replacement (option **7**). In addition, set timing values relating to the shutdown and restart of the UPS via this function. This information is accessible via the HTTP interface for easy modification after the card is on the network.

Set Superuser Name and Password

Use this function to set or change the user name and password of the administrator who will use a Web browser to configure the ConnectUPS Web/SNMP Card (option **8**).

Email Notification

Use this function to inform selected e-mail accounts of events and changes in the status as they occur in the UPS or to provide a daily status message at a predetermined time (option **9**). This information is accessible via the HTTP interface for easy modification after the card is on the network.

Set Website Links

Use this function to set links to different Web sites (option **10**). Links appear on the Web pages of the ConnectUPS Web/SNMP Card. This information is accessible via the HTTP interface for easy modification after the card is on the network.

Back to Main Menu

Type **0** to return to the Main Menu screen (see Figure 7 on page 13).



CHAPTER 4

REMOTE CONFIGURATION

Use the following procedure to access the card's configuration program through a Web browser.



NOTE Verify that an active 10/100BaseT cable is connected to the card's network connector (the Uplink Ethernet connector on the ConnectUPS-X).

Add a Routing Condition in the Computer

If the IP address of the computer is on the same network with the ConnectUPS Web/SNMP Card, you may just run the Web browser directly.

If the IP address of the computer is not on the same network with the ConnectUPS Web/SNMP Card (only required while configuring the card), you can use the Add Routing command.

1. Turn on the computer and set up the TCP/IP protocol if needed.
2. Enter the following command to add a routing condition:

Route add 192.168.7.18 192.72.173.20

where 192.168.7.18 is the default IP address of the card and 192.72.173.20 is an example IP address for the computer.



NOTE Refer to your operating system documentation for additional details on how to add a routing condition.

Running the Web Browser

Locate a computer (PC, host, or server) that has a Web browser (Internet Explorer or Netscape recommended) and is connected to a network.

1. Run the Web browser and connect to the ConnectUPS Web/SNMP Card IP address (the default is 192.168.7.18).
2. The home page of the ConnectUPS Web/SNMP Card appears (see Figure 8).

The screenshot shows the ConnectUPS Web/SNMP Card interface. At the top, there is a navigation bar with the following tabs: Identification, UPS Monitoring, UPS History, Configuration, Control, Registered Clients, and Help. The 'Identification' tab is currently selected. Below the navigation bar, the text 'UPS Identification:' is displayed. To the right of this text, a list of system parameters is shown in two columns:

UPS Model	Powerware 9170
VA Rating	3000 VA
UPS Type	Parallel Redundant On-Line UPS, Two Phase
UPS Serial Number	C651M30001010000
Identification Information	UPS Web Card
UPS Location	Software Lab #2
UPS Administrator	Gropisky, Sam
Date of Installation	01/01/2002
Battery Last Replaced Date	01/01/2002
ConnectUPS Web/SNMP Card Up-Time 0 days 0 hours 3 mins 39.02 secs.	

Below the list of parameters, there is a button labeled 'Become Superuser'. At the bottom left of the page, the 'Powerware' logo is visible.

Figure 8. ConnectUPS Web/SNMP Card Home Page

Setup Network Configuration

1. Select **Configuration** from the menu at the top of the home page, then **Web/SNMP Card Configuration** to set the ConnectUPS Web/SNMP Card parameters (see Figure 9).
2. Click **Become Superuser** and log in with the *Username* and *Password* (the default user name and password is *admin*).

ConnectUPS™ Web/SNMP Card

Identification	UPS Monitoring	UPS History	Configuration	Control	Registered Clients	Help
UPS Event Actions	UPS Shutdown and Restart Settings	UPS Shutdown Schedule	Web/SNMP Card Configuration	SNMP Trap Receivers	Email Notification	Date and Time Help

Web/SNMP Card Configuration:

Firmware Revision	ConnectUPS Web/SNMP Card V1.1
MAC Address	00-E0-D8-FF-85-C7
ConnectUPS Web/SNMP Card IP Address	10.222.51.185
Gateway Address	10.222.51.254
Subnet Mask	255.255.255.0
Primary Date Server	0.0.0.0
Secondary Date Server	0.0.0.0
Website Link 1 IP Address	www.powerware.com
Website Link 1 Screen Text	Powerware
Website Link 2 IP Address	
Website Link 2 Screen Text	
History Log Frequency (minutes)	1
BOOTP/DHCP Control	Disabled
Telnet Control	Enabled
TFTP Upgrade Control	Enabled
HTTP and Telnet Security Control	Disabled
Reset Configuration to Default	No
Restart ConnectUPS Web/SNMP Card	No

Figure 9. ConnectUPS Web/SNMP Card Configuration Page

3. Select and edit the **ConnectUPS Web/SNMP Card IP Address**.
4. Select and edit the **Gateway Address** for the network.
5. Select and edit the **Subnet Mask** of the network.
6. Select **Set Values** to save the new settings.



NOTE If you changed the IP address in Step 3, you must restart the browser using the new IP address (see page 18) to restore communication with the ConnectUPS Web/SNMP Card. Repeat Steps 1 and 2 to continue the configuration.

7. Select **Date and Time** from the menu at the top of the page.
8. Enter the appropriate date and time information in the specified format.
9. Select **Set Values** to save the date and time settings.

The ConnectUPS Web/SNMP Card is now configured for operation on your network. Refer to the remainder of this user's guide and the online help for detailed information about each menu selection.



CHAPTER 5

UPS POWER MANAGEMENT

You can manage the UPS from a Web browser or from an SNMP network management system.

UPS Management from a Web Browser

When using a Web browser to access the ConnectUPS Web/SNMP Card, the majority of UPS-related information is available by selecting any of the following menu options:

- Identification
- UPS Monitoring
- UPS History
- Configuration
- Control
- Registered Clients
- Help

Each menu and submenu selection has online help available.

Viewing Status@aGlance

Status@aGlance is a page that provides a simple, intuitive way to view UPS status information and is accessed through a link on the UPS Monitoring > UPS Status page. It changes the background color of the page to reflect the UPS status:

- green indicates normal UPS operation
- yellow indicates the UPS is responding to a problem (the UPS is on battery during a power outage; the UPS has one or more alarms present; or the UPS has been bypassed)
- red indicates a low battery condition and shutdown is imminent
- black indicates a loss of communication between the UPS and the ConnectUPS Web/SNMP Card

If you leave the browser pointed to this page, it automatically updates when new UPS information is available. To return to the UPS Status page, point and click the mouse pointer anywhere within the colored background area.

ConnectUPS MultiView Software

The Status@aGlance pages of several ConnectUPS Web/SNMP Cards may be monitored simultaneously by installing the ConnectUPS MultiView software on a PC with Microsoft Windows 95/98/Me/NT/2000/XP.

The software is included on the CD-ROM supplied with the ConnectUPS Web/SNMP Card or it can be downloaded from the ConnectUPS Web/SNMP Card Web page (the [Download ConnectUPS MultiView](#) link on the Identification page or on the UPS Monitoring page).

The ConnectUPS MultiView software works in tandem with Internet Explorer to discover and display multiple browser windows, each representing a different ConnectUPS Web/SNMP Card. You also have the flexibility to pick other Web pages as presented by the ConnectUPS Web/SNMP Card during configuration.

Becoming a Superuser

Several menus allow UPS and ConnectUPS Web/SNMP Card parameters to be modified by the user. However, many of these are password-protected for the Superuser. To become a Superuser, you must log in with a user name and provide a password. Both are configurable by serial or Telnet connection. The default user name and password is *admin*.



NOTE Once you have become a Superuser, it is important to completely exit the browser if you wish to set the security level back to the standard read-only level.

Turning the UPS On and Off

The ConnectUPS Web/SNMP Card supports the ability to remotely turn off the UPS and its supported load. It also supports the ability to reboot the UPS (cycling output power off and then back on), as well as the ability to schedule shutdowns and startups on a predetermined basis.

Selecting **Control** from the menu at the top of the home page provides a page that allows the Superuser to turn off the UPS. In addition, you may initiate a battery test and enable or disable any scheduled shutdowns or startups as specified in the UPS shutdown schedule table (accessed from the Configuration menu).



CAUTION

- Selecting **Turn UPS Off** turns off the output of the UPS. Any equipment powered by the UPS shuts down. Prepare the protected equipment for the shutdown.
- If you select **Turn UPS Off** with **Load Segment to Restart following the Return of AC Power** set to **NO**, you will have to manually restart the UPS after the shutdown occurs.

Forcing the UPS to Shut Down

1. Select **Configuration** from the menu at the top of the home page, then **UPS Event Actions**.
2. Log in as a Superuser.
3. Select **UPS Shutdown and Restart Settings**.
4. Verify **Load Segment to Turn Off following OS Shutdown** is set to **YES**.
5. Set the appropriate **Delay Before Segment Turns Off following the start of the Client's OS Shutdown** in seconds to ensure that any NetWatch clients and their respective operating systems have enough time to complete their shutdown. The default is 180 seconds, but you may wish to increase or decrease this value as appropriate for your system.

6. To turn off the UPS and have it stay off (requiring local interaction to turn it back on), change **Load Segment to Restart following the return of AC Line** to **NO**.
If you want to effectively reboot the UPS and the associated load, then set **Load Segment to Restart following the return of AC Line** to **YES** and set **Delay Before Segment Restart** to a valid delay value to allow the UPS to restart after the specified delay.
7. After choosing the desired values, select **Set Values** to update the card with the new information.
8. Select **Control** from the ConnectUPS Web/SNMP Card menu at the top of the home page and select **Load Segment "ALL"** or the appropriate load segment **"NUMBER(S)"**. Then select **Turn UPS Off**.
9. To initiate the shutdown sequence, select **Set Values** which instructs the ConnectUPS Web/SNMP Card to send the appropriate information to the UPS and any clients running the NetWatch client software.

Planning a Scheduled UPS Shutdown and Restart

You may use the ConnectUPS Web/SNMP Card to schedule the day of the week and time of a shutdown and a startup. The ability to schedule shutdowns and startups is UPS dependent (consult your UPS documentation for more information).

1. Select **Configuration** from the menu at the top of the home page, then **UPS Shutdown Schedule**.
2. Login as a Superuser.
3. You may configure up to seven event pairs. Enter the upcoming **Shutdown Day** and **Shutdown Time**, and if needed, the **Restart Day** and **Restart Time**. Times are in 24-hour format based on the date and time set within the ConnectUPS Web/SNMP Card.
4. Click **Set Values** to update the card.
5. Once the values are set, select **Control** from the menu at the top of the home page.

6. Then select **Enable UPS Shutdown Schedule**, followed by **Set Values** to start the process. Any shutdown/restart events repeat until you change the table or select **Disable UPS Shutdown Schedule**.



NOTE Before scheduling any shutdowns or startups, you must configure the date and time within the ConnectUPS Web/SNMP Card.

Configuring E-mail Notification

You may use the ConnectUPS Web/SNMP Card to inform selected e-mail accounts of events and changes in status as they occur in the UPS or to provide a daily status message at a predetermined time.

1. Select **Configuration** from the menu at the top of the home page, then **Email Notification**.
2. Become a Superuser and then enter the IP address or Hostname of an SMTP mail server that will be used to send the e-mail messages.
3. If you entered a host name for the **Mail Server**, you must enter the IP address of your network DNS Server in the **DNS Address** block.
4. To receive a daily status report, enter the time of day to send the e-mail (in 24-hour format).
5. Enter the **Mail Account**, **Description**, **Mail Type**, **Event Level**, and **Event Type** for each recipient. The Mail Account must be a valid e-mail address. Refer to the online help file for more details on each of these fields.
6. Select **Set Values** to save your changes.
7. Test your settings by pressing the **Send Test** button.

The ConnectUPS Web/SNMP Card uses the Identification Information field data and the card's IP address to create the sender's e-mail address (default example: UPS.Web.Card@192.168.7.18).

You can change the Identification Information field to a more recognizable sender user name by accessing the Identification

page with your browser. This is especially helpful if you have more than one ConnectUPS Web/SNMP Card and intend to receive e-mails at a central location.

If your SMTP server requires a qualified domain name instead of an IP address or requires a qualified user name in the sender's email address, additional configuration items are available with a serial or Telnet connection (see Chapter 3, "Local Configuration" on page 9). SMTP configuration options are available through **Email Notification** on the Web/SNMP Card Settings menu. Under most circumstances, changes are not required for these options.



NOTE To completely clear the contents of any configuration item, enter a tilda (~) and press the Enter key.

- **SMTP Port Number** – SMTP server access is typically gained via port 25. For installations where a different port number is used, configure the port number using this option.
- **Substitute Domain Name for Sender's Email Address** – The default domain name for the sender's e-mail address is the ConnectUPS Web/SNMP Card's IP address. You can enter a qualified domain name with this option.
- **Optional SMTP Username** – The ConnectUPS Web/SNMP Card's Identification Information field data is used as the user name for the SMTP server as well as in the sender's e-mail address. Use this option to configure a qualified user name.

Note that the text used in the Identification Information field remains unaffected; this text is also used to display additional information when browsing the card.

- **Optional SMTP Password** – Under certain circumstances, a password may be required to obtain access to a SMTP server. If your server requires a password, enter it here.

When changing any e-mail configuration items, it is strongly recommended to use the **Send Test** function to test your changes. Any e-mail errors are logged in the ConnectUPS Web/SNMP Card Event Log. Review the Event Log within a few minutes of testing the e-mail to see if any errors are logged.

Performing a Manual UPS Battery Test

You can use the ConnectUPS Web/SNMP Card to manually perform a UPS battery test. The ability to test the UPS is model dependent (consult your UPS documentation for more information).

1. To manually start a battery test on a specific UPS, select **Control** from the menu at the top of the home page.
2. Become a Superuser and then select **Initiate Battery Test**, followed by **Set Values** to start the process.

Viewing the UPS History Logs

Selecting **UPS History** from the menu at the top of the home page allows you to choose the current **UPS Data Log** and **UPS Event Log**. The data log provides numerical data logged once a minute from the UPS. The event log contains text messages regarding the status of the UPS and the ConnectUPS Web/SNMP Card. Past data and event logs are also accessible, as well as a data log applet that displays the data in a graphical format.

UPS Management from an SNMP NMS

To access the ConnectUPS Web/SNMP Card via SNMP, use the following steps:

1. Use these Community strings:
GET Community string: *public*
SET Community string: *private*

By default, the ConnectUPS Web/SNMP Card's Write Access Managers table is configured for read-only SNMP access to any NMS with a *public* community string. An NMS with a *private* community string has read/write SNMP access.



NOTE For security, it is recommended to change the Write Access Managers table using specific IP addresses and nonstandard community strings.

2. The *xups.mib* and *stdupsv1.mib* files (on the supplied CD-ROM) contain the MIB for the ConnectUPS Web/SNMP Card. Add these files to the MIB database of your SNMP management software (such as HP OpenView,[™] IBM[®] Director, and Sun NetManager).
3. Using the Facilities provided by the SNMP management software, you can access the individual MIB objects. Refer to the MIB files on the supplied CD-ROM for more information.

Viewing UPS Monitoring Parameters

The ConnectUPS Web/SNMP Card supports several MIB groups that separate specific UPS parameters into related areas. The groups used in the MIB for the card include:

- Ident
- Battery
- Input
- Output
- Config
- Control
- Test
- Alarms
- Bypass
- Traps

Forcing the UPS to Shut Down

The ConnectUPS Web/SNMP Card supports MIB groups containing objects that enable the user to shut down and restart the UPS.

Receiving Event Traps

The ConnectUPS Web/SNMP Card supports several event-related traps, that can be reported to the SNMP network management software. Refer to the MIB files found on the supplied CD-ROM for more information.

Automatic Shutdown of UPS-Protected Computers

NetWatch client software supports remote UPS monitoring and automatic shutdown of UPS-protected computer systems and is available on the supplied CD-ROM or from www.powerware.com.

Clients are available for the following operating systems:

- Microsoft Windows 95/98/Me/NT/2000/XP
- Novell NetWare
- UNIX (various versions, including Linux)

Each NetWatch client uses its IP address to register with a specified ConnectUPS Web/SNMP Card via the network. Once a client has registered, any change in UPS status is communicated to NetWatch. Depending on the operating system, NetWatch typically alerts the user(s) whenever the UPS begins supplying AC power from its batteries (for example, the AC line fails). Then, if AC line power does not return and the remaining battery time is low, NetWatch takes over and completes an operating system shutdown prior to the UPS running out of battery power.

Settings found in the UPS Event Actions and UPS Shutdown page and the Restart Settings page are related to the automatic shutdown of the UPS-protected computer system using NetWatch. By default, the ConnectUPS Web/SNMP Card initiates an automatic shutdown only during a low battery condition. The ConnectUPS Web/SNMP Card allows 180 seconds for the NetWatch-protected systems to complete their operating system shutdown before the UPS power is turned off. When the power returns, the UPS automatically restarts after a 30-second delay and supplies power to the load.



APPENDIX

The appendix contains the card specifications, DIP switch and jumper settings, upgrading the firmware, service and support, and the warranty.

Table 3. Technical Specifications

CPU	AC1101
Memory	1024k × 8 Static DRAM 1024k × 8 Flash ROM
LAN Controller	AC1102
Network Connection	10/100BaseT RJ-45 network connector (ConnectUPS-X provides 3 additional connectors for your devices)
UPS Protocol	Powerware UPS communication protocol
Network Protocol	HTTP over TCP/IP SNMP over UDP/IP SMTP, ARP, RARP, and TFTP BOOTP, DHCP
Supported MIB	Powerware (XUPS.MIB) RFC-1628 Standard UPS (STDUPSV1.MIB)
OS Supported for Shutdown	Microsoft Windows 95/98/Me/NT/2000/XP Novell NetWare Various UNIX versions, including Linux
Operating Temperature	0–40°C (32–104°F)
Operating Humidity	10–80%, noncondensing
Power Input	9 Vdc unregulated
Power Consumption (maximum)	3.5 watts
Size (L x W x H)	ConnectUPS-X: 12 cm x 11.4 cm x 39 cm (4.7" x 4.5" x 1.5") ConnectUPS-BD: 13.4 cm x 81 cm x 33 cm (5.3" x 3.2" x 1.3")
Weight	200 gm (7 oz)
EMC Statements (Class B)	FCC Part 15, ICES-003, CE

DIP Switch Description

DIP switch definitions for both types of the ConnectUPS Web/SNMP Cards are listed in Table 4.

Table 4. DIP Switch Modes

SW1	SW2	Description
Off	Off	Operational Mode (default)
Off	On	BOOTP/DHCP Enable Mode (overrides the serial/Telnet configuration)
On	Off	Reserved
On	On	Reserved

Jumper 1 (JP1) Settings

The JP1 jumper is found on both the ConnectUPS-X and ConnectUPS-BD. The JP1 pins are NOT jumpered by factory-default. Table 5 shows the jumper definitions.

Table 5. JP1 Definitions

Jumper Setting	Definition
1 and 2	Allows <i>admin</i> to be entered as the password when the programmed Superuser password has been forgotten
3 and 4	Disables all changes to the card's configuration

NOTE On the ConnectUPS-BD, jumper positions 5 and 6, 7 and 8 are undefined; DO NOT jumper these positions.

Upgrading the Card Firmware

During the upgrade process, the ConnectUPS Web/SNMP Card is inaccessible, but restarts automatically within a minute after completing the upgrade.

To upgrade the ConnectUPS-X or ConnectUPS-BD firmware, use the following steps:

1. Locate a networked PC with Microsoft Windows 95/98/Me/NT/2000/XP.
2. Copy the supplied Firmware Upgrade Utility (*upgrade100.exe*) program to the PC.
3. Run the Upgrade Utility from Microsoft Windows by selecting **Start, Run**, and then entering the path and filename *upgrade100.exe*.
4. Assuming that the network (TCP/IP) connection for the PC can reach the card needing the firmware upgrade, select **Discover** which instructs the utility to attempt to find all reachable 10/100 ConnectUPS Web/SNMP Cards on the network. Any cards that are found are displayed in the table.
Discover searches only the current subnet. To upgrade a card that is reachable, but not on the subnet, click the **Add** button and provide the requested information.
5. Activate the checkbox by the ConnectUPS Web/SNMP Card(s) to be upgraded (up to four cards at a time under most network conditions).

6. Highlight the ConnectUPS Web/SNMP Card IP address to select the individual card. Click **Modify** and enter the Superuser name and password. Repeat this step for each card that will be upgraded.
7. Select **Open** next to **Filename** and select the binary upgrade file that was previously downloaded or otherwise received and copied to the PC.

Select **Upgrade** to start the process. After the process starts, do not cancel or interrupt the upgrade process. Otherwise, the ConnectUPS Web/SNMP Card receives a corrupted image, preventing the card from operating correctly.
8. When the Upgrade Utility completes, exit the program by selecting **Quit** and then answering **Yes** to the confirmation.

Service and Support

If you have any questions or problems with the UPS, call your **Local Distributor** or the **Help Desk** at one of the following telephone numbers and ask for a UPS technical representative.

In the United States: **1-800-356-5737** or **1-608-565-2100**
Europe, Middle East, Africa: **+44-17 53 608 700**
Asia: **+852-2830-3030**
Australia: **+61-3-9706-5022**

Please have the following information ready when you call the Help Desk:

- Model number
- Serial number
- Version number (if available)
- Date of failure or problem
- Symptoms of failure or problem
- Customer return address and contact information

If repair is required, you will be given a Returned Material Authorization (RMA) Number. This number must appear on the outside of the package and on the Bill Of Lading (if applicable). Use the original packaging or request packaging from the Help Desk or distributor. Units damaged in shipment as a result of improper packaging are not covered under warranty. A replacement or repair unit will be shipped, freight prepaid for all warranted units.



NOTE For critical applications, immediate replacement may be available. Call the **Help Desk** for the dealer or distributor nearest you.

Two-Year Limited Warranty (US and Canada Only)

Powerware Corporation warrants the electronics of the ConnectUPS Web/SNMP Card to be free from defects in material and workmanship for a period of two years from Date of Purchase. If, in Powerware Corporation's opinion, the electronics fails to meet its published specifications due to a defect in material and workmanship covered by this warranty, Powerware Corporation will repair or replace the warranted Unit at no cost to the customer for parts and labor.

Equipment supplied by Powerware Corporation, but not manufactured by Powerware Corporation, is warranted solely by the manufacturer of such equipment. Powerware Corporation does not warrant equipment not manufactured by Powerware Corporation.

This warranty does not apply to any Unit that has been subject to neglect, accident, abuse, misuse, misapplication, incorrect connection or that has been subject to repair or alteration not authorized in writing by Powerware Corporation's personnel. THIS WARRANTY IS THE PURCHASER'S (USER'S) SOLE REMEDY AND IS EXPRESSLY IN LIEU OF ANY OTHER WARRANTY, AND THERE ARE NO OTHER EXPRESSED OR IMPLIED GUARANTEES OR WARRANTIES (INCLUDING ANY IMPLIED WARRANTY OF MERCHANTABILITY OR FITNESS FOR PURPOSE). In no case will Powerware Corporation's liability under this contract exceed the value of the Unit furnished.

In no event shall Powerware Corporation be liable for any indirect, incidental, special or consequential damages. Powerware Corporation shall not be responsible for failure to provide service or parts due to causes beyond Powerware Corporation's reasonable control. THIS LIMITED WARRANTY IS VOID UNLESS USER RETURNS TO POWERWARE CORPORATION THE INCLUDED WARRANTY REGISTRATION CARD WITHIN THIRTY (30) DAYS OF DELIVERY.

Any advice furnished the Purchaser (User) before or after delivery in regard to use or application of Powerware Corporation equipment is furnished without charges and on the basis that it represents Powerware Corporation's best judgement under the circumstances. The use of any such advice by the Purchaser (User) is solely and entirely at his or her own risk.

This limited warranty applies only to equipment installed in the fifty United States of America and Canada. In other countries, consult your local distributor.

Extended Service Coverage

A full complement of warranty extensions and enhancements are available from Powerware Corporation for your UPS. Information pertaining to these services should be available in the shipping container along with this manual. If not, or if you would like more information, call the Powerware Corporation **Help Desk** and ask about warranty services.

International Limited Warranty

Powerware Corporation warrants the electronics modules manufactured by Powerware Corporation ("Unit") and batteries originally packaged in the Unit or in battery packs manufactured by Powerware Corporation against defect in material or workmanship until the earlier of: (1) 18 months from date of shipment or (2) 12 months from date of initial start-up is performed by Powerware Corporation field personnel or field personnel authorized by Powerware Corporation to carry out such service efforts on its behalf and provided that, startup occurs no later than 6 months after shipment. If the unit does not function in accordance with its published specification, the user should give Powerware Corporation prompt notice thereof and if requested by Powerware Corporation, the user shall return the warranted Unit or parts thereof to the plant or service station designated by Powerware Corporation for inspection by Powerware Corporation. Any Unit which may require repair and/or replacement of parts as the result of defects in workmanship or material within the stated warranty period, will be replaced or repaired at Powerware Corporation's option without charge for replacement parts. The cost of shipment, duties or all other expenses associated with shipment of repaired or replaced items is for the account of the user.

Powerware Corporation will not be responsible or liable for work done or expense incurred in connection with repair or replacement except as expressly authorized by Powerware Corporation, Raleigh, NC, USA in writing. If a service engineer is required, labor, at current published rates, and all travel and living expenses are for the account of the user.

Powerware Corporation does not warrant equipment not manufactured by Powerware Corporation including any battery not originally packaged with the Unit or in battery packs manufactured by Powerware Corporation. The manufacturer of all such equipment shall solely warrant that equipment and Powerware Corporation shall have no responsibility or liability thereof.

IT IS AGREED THAT Powerware Corporation, ITS PARENT COMPANY, OR ANY OF THEIR AFFILIATES, SHALL HAVE NO LIABILITY FOR INDIRECT, INCIDENTAL, SPECIAL, OR CONSEQUENTIAL DAMAGES, AND THAT THERE IS NO WARRANTY, EITHER EXPRESSED OR IMPLIED BY LAW OR THE PARTIES HERETO, OTHER THAN THOSE EXPRESSLY SET FORTH HEREIN. THIS WARRANTY DOES NOT COVER DAMAGE TO THE UNIT CAUSED BY MISUSE, ABUSE, NEGLIGENCE, UNAUTHORIZED MODIFICATIONS, IMPROPER MAINTENANCE, ACCIDENTS OR OTHER ABNORMAL CONDITIONS.

Force Majeure

Powerware Corporation shall not be liable for any delays or defaults hereunder by reason of fire, floods, acts of God, labor troubles, accidents to machinery, delays of carriers or suppliers, inability of suppliers to supply, the impositions of priorities, restrictions or other acts of government, or other causes beyond its reasonable control.

This Warranty shall be governed by the laws of the State of North Carolina, USA in all respects.