



Timetable Planning Rules

London North Eastern

2019 TIMETABLE

Version 2.0

Issued by David Walgate
Timetable Production Manager
The Quadrant MK
Elder Gate
Milton Keynes

Tel: 07825 376830
Final Revised Rules for Principal Change Timetable 2019
2nd February 2018



Timetable Planning Rules

London North Eastern

2019 TIMETABLE

Version 2.0

Issued by David Walgate
Timetable Production Manager
The Quadrant MK
Elder Gate
Milton Keynes

Tel: 07825 376830
Final Revised Rules for Principal Change Timetable 2019
2nd February 2018

Contents

Section	Page no.	Section	Page no.
1 Introduction and General Notes.....	3	5.1 Sectional Running Times	74
1.1 Index of Routes.....	4	5.1.1 Source of Current SRTs.....	74
1.2 Sectional Appendices and Rule Book.....	7	5.1.2 Method of Calculation	74
1.2.1 Sectional Appendix	7	5.1.3 New and Revised Sectional Running Times.....	75
1.2.2 Rule Book.....	7	5.1.4 Timing of Trains Consisting of Passenger Vehicles on Goods Lines	75
1.3 Definitions.....	9	5.2 Headways	75
1.3.1 Train Classification.....	9	5.2.1 Headway Values	75
1.3.2 Days of Operation	9	5.2.2 General Capacity Constraints	101
1.3.3 Traction and Rolling Stock.....	11	5.3 Junction Margins and Station Planning Rules.....	102
1.3.4 Line Codes.....	11	5.4 Platform Lengths	255
1.3.5 Activity and Other Codes.....	12	5.4.1 Loop Lengths	272
2 Route Description	14	5.5 Timing Allowances.....	273
2.1 Planning Geography.....	14	5.5.1 SX Daytime (See routes for applicable times).....	273
2.2 Route Opening Hours.....	61	5.5.2 SX Nighttime (See routes for applicable times).....	289
3 Electrification.....	72	5.5.3 SO Daytime (See routes for applicable times).....	291
3.1 Electrification Limits.....	72	5.5.4 SO Nighttime (See routes for applicable times).....	291
3.2 Electrification Supply Restrictions.....	72	5.5.5 SUNDAY Daytime (See routes for applicable times)	293
4 Rolling Stock Restrictions	73	5.5.6 Sunday Night time (See routes for applicable times)	301
4.1 Locomotive Route Availability	73	6 Timetabling Considerations	304
4.2 Passenger Stock Restrictions	73	6.1 Advertised and Working Times.....	304
4.3 Freight Wagon Restrictions.....	73	6.2 Timing of Light Locomotives.....	304
4.4 Freight Train Load Limits	73	7 Appendix A Timing Point Diagrams.....	305
4.5 Freight Train Length Limits.....	73		
5 Running Times, Margins and Allowances.....	74		

1 Introduction and General Notes

Network Rail provide the Timetable Planning Rules document to Train Operators and other interested parties to set out the rules which are applicable to Access Requests for scheduling of train paths on the Network Rail network. Separate sections of Timetable Planning Rules are prepared for each Route with a National Timetable Planning Rules document setting out procedures to be followed and other nationally applicable rules.

Network Rail will determine the contents of Timetable Planning Rules through consultation with Train Operators with the primary aim of achieving the optimal balance between access to the network for train operations and performance robustness of the resulting train plan. This consultation is in line with the Network Code Part D, and Train Operators have a right of appeal to Timetabling Sub-Committee against the contents of the Final Timetable Planning Rules.

Final Timetable Planning Rules are issued with timetable Access Request Information before the commencement of the development period for the Principal Change timetable to which the Rules apply and cover a 12-month period. Revised Timetable Planning Rules are issued with timetable Access Request Information before the commencement of the Subsidiary Change timetable development period and show changes applicable to the Subsidiary Change timetable period which have been agreed since the issue of the annual Timetable Planning Rules.

Timetable Planning Rules may be changed only through this twice-yearly process or by the change procedure described in the National Timetable Planning Rules.

Train Operators' Access Requests for train paths must be compliant with Timetable Planning Rules. If a Train Operator wishes to submit an Access Request for a train path which is not compliant with Timetable Planning Rules it should consult the Network Rail Capacity Planning team to establish whether an amendment to Timetable Planning Rules is likely to be agreed and, if appropriate, submit an amendment proposal which will be considered by Network Rail in accordance with the Change Procedure set out in the National Timetable Planning Rules. The Timetable Planning Rules amendment proposal should be submitted to Network Rail as early as possible and certainly no later than the time of submission of the Access Request. If the proposed change is likely to involve the calculation of new sectional running times or a physical investigation then the Train Operator should liaise with the Network Rail Capacity Planning team to establish a realistic timescale for evaluation of the proposed change before submission of the Access Request.

1.1 Index of Routes

Information arranged on a line of route basis in this document is presented in the following order:

LN101	London King's Cross to Shaftholme Jn
LN105	Moorgate to Finsbury Park Jn
LN110	Canonbury West Jn to Finsbury Park Jn
LN115	Copenhagen Jn to Camden Road Central Jn
LN120	Wood Green North Junction to Langley Jn (via Hertford)
LN125	Hitchin Cambridge Jn to Royston (inclusive)
LN126	Hitchin North Junction to Hitchin East Junction
LN135	King's Dyke to Crescent Junction
LN147	Helpston Junction to Uffington
LN150	Flyover East Jn to Decoy North Jn
LN155	Flyover East Jn to Loversall Jn (Up Loversall Curve)
LN160	Loversall Carr Jn to Flyover West Jn
LN165	Harringay Park Jn to Harringay Jn
LN170	Werrington Jn to Flyover East Jn (via Lincoln)
LN175	Sleaford South Jn to Sleaford East Jn
LN180	Sleaford West Jn to Sleaford North Jn
LN185	Allington West Jn to Skegness
LN190	Allington East Jn to Allington North Jn (Allington Chord)
LN195	Grantham Nottingham Branch Jn to Allington West Jn(inclusive)
LN200	Wrawby Jn to Pelham Street Jn
LN206	Newark Flat Crossing (inclusive) to West Holmes Jn
LN210	Newark Crossing Curve line
LN215	Boultham Jn to Pyewipe Jn
LN220	Bessacarr Jn to Black Carr Jn
LN235	Rossington Colliery Branch
LN600	Shaftholme Jn to Reston GSP
LN618	Holgate Jn to Skelton Jn
LN620	King Edward Bridge East Jn to King Edward Bridge North Jn
LN622	Forth branch
LN624	Northallerton Castle Hills Jn to Castle Hills West GF
LN626	Northallerton High Jn to Northallerton East Jn
LN627	Longlands Jn to Newcastle East Jn via the Coast
LN628	South Hylton to Sunderland South Jn
LN629	Pelaw Metro Jn to Pelaw South Jn
LN630	Pelaw North Jn to Pelaw Metro Jn
LN631	Darlington South Jn to Eaglescliffe South Jn
LN632	Stockton Cut Jn to Saltburn
LN634	Guisborough Jn to Whitby
LN636	Beam Mill Jn to Slag Road (Lackenby)
LN638	Grangetown Shell Jn to Cleveland Freightliner Terminal (Wilton)
LN640	ICI Wilton Coal Terminal
LN642	Saltburn West Jn to Boulby Potash Mine
LN644	Hartburn Jn to Bowesfield Jn
LN646	Norton-on-Tees South to Ferryhill South Jn
LN648	Norton-on-Tees West to Norton-on-Tees East
LN652	Billingham Jn to Seal Sands Storage
LN656	Seaton-on-Tees Branch
LN662	Ryhope Grange Jn to Hendon (Sunderland Docks)
LN664	Boldon East Jn to Boldon North Jn
LN666	Boldon West Jn to Tyne Dock

LN670	Jarrow Branch
LN674	High Level Bridge Jn to Greensfield Jn
LN676	Park Lane Jn to King Edward Bridge South Jn
LN678	Darlington North Jn to Eastgate
LN682	King Edward Bridge South Jn to Petteril Bridge Jn
LN684	Low Fell Jn to Norwood Jn
LN694	Benton North Jn to Morpeth North Jn via Bedlington
LN696	Hepscott Jn to Morpeth Jn
LN698	Butterwell South Branch
LN700	Butterwell North Branch
LN702	Bedlington North Jn to Lynemouth Alcan
LN706	West Sleekburn Jn to North Blyth
LN708	Winning Jn to Marchey's House Jn
LN724	Holgate Jn to Skelton Jn
LN736	Cleethorpes to Nunnery Main Line Jn via Retford
LN738	Great Coates No.1 to Union Dock
LN740	Grimsby Marsh West Jn to Humber Road Jn
LN741	Habrough Jn to Ulceby South Jn
LN742	Killingholme to Brocklesby Jn
LN744	Ulceby North Jn to Barton on Humber
LN746	Cottam Power Station to Clarborough Jn
LN748	Retford Western Jn to Thrumpton West Jn
LN750	Woodburn Jn to Deepcar
LN752	Wrawby Jn to Marshgate Jn
LN754	Scunthorpe Foreign Ore Branch
LN756	Scunthorpe Trent Jn to Roxby
LN758	Brancliffe East Jn to Kirk Sandall Jn
LN762	St Catherine's Jn to Decoy South Jn
LN764	St Catherine's Jn to Potteric Carr Jn (Low Ellers Curve)
LN766	Bentley Jn to Hexthorpe Jn (Doncaster Avoiding Line)
LN768	Mansfield Woodhouse to Shireoaks East Jn
LN772	Warsop Jn to Shirebrook Jn
LN774	Barrow Hill North Jn to Oxcroft Disposal Point
LN776	Hall Lane Jn to Foxlow Jn
LN778	Seymour Jn to Bolsover
LN782	Woodend Jn to Shireoaks West Jn
LN784	High Marnham to Shirebrook East Jn
LN786	Bevercotes Colliery Branch
LN788	Thoresby Colliery Branch
LN790	Rufford No.1 Coal Stacking Site to Clipstone East Jn
LN800	Clipstone South Jn to Clipstone West Jn
LN802	Welbeck Colliery Branch
LN804	Tapton Jn to Gascoigne Wood Jn via Sheffield
LN806	Tapton Jn to Masborough Jn via 'Old Road'
LN807	Dore South Jn to Dore West Jn
LN808	Dore Station Jn to Totley Tunnel East
LN809	Shepcote Lane West Jn to Tinsley Yard East End
LN810	Shepcote Lane West Jn to Tinsley South Jn
LN812	Shepcote Lane East Jn to Broughton Lane Jn
LN814	Tinsley North Junction to Sheffield Tram W210
LN815	Parkgate Junction to Sheffield Tram Parkgate
LN816	Beighton Jn to Woodhouse Jn
LN818	Holmes Jn to Rotherham Central Jn (Holmes Curve)
LN824	Moorthorpe Jn to South Kirkby Jn

LN826	Doncaster South Yorkshire Jn to Swinton
LN828	Mexborough Jn to Aldwarke Jn via Kilnhurst
LN830	Aldwarke Jn to Woodburn Jn
LN832	Doncaster Bridge Jn to St. James Jn
LN836	Doncaster Marshgate Jn to Neville Hill East Jn
LN838	Leeds Armley Jn to York Skelton Jn via Harrogate
LN840	Engine Shed Jn to Whitehall East Jn
LN842	Thorpe Marsh Jn to Adwick Jn
LN844	Applehurst Jn to Joan Croft Jn (Applehurst Loop)
LN846	Carcroft Jn to Skellow Jn
LN848	Hare Park Jn to Crofton West Jn
LN850	Wakefield Westgate South Jn to Wakefield Kirkgate West Jn
LN852	Holbeck Jn to Bradford Interchange
LN854	Hall Royd Jn to Colton Jn
LN858	Milner Royd Jn to Bradford Mill Lane Jn
LN859	Greetland Jn to Dryclough Jn
LN860	Diggle Jn to Copley Hill East Jn
LN861	Bradley Jn to Bradley Wood Jn
LN862	Barnsley Station Jn to Huddersfield
LN864	Dewsbury Railway Street Branch
LN868	Wincobank Jn to Horbury Jn via Barnsley
LN870	Turner's Lane Jn to Calder Bridge Jn
LN872	Altofts Jn to Leeds West Jn
LN874	Methley Jn to Whitwood Jn
LN875	Castleford West Jn to Pontefract West Jn
LN878	Sherburn Jn to Gascoigne Wood
LN880	York to Scarborough
LN882	Wakefield Kirkgate West Jn to Goole Potter's Grange Jn
LN884	Oakenshaw South Jn to Oakenshaw Jn
LN886	Monk Bretton Loop to Crofton East Jn
LN888	Hatfield and Stainforth (Stainforth Jn) to Ferrybridge North Jn
LN889	Shaftholme Jn to Haywood Jn
LN892	Pontefract East Jn to Ferrybridge South Jn
LN894	Knottingley South Jn to Knottingley East Jn
LN896	Drax Power Station Branch
LN898	Neville Hill East Jn to Hull
LN900	Neville Hill West Jn to Hunslet East
LN902	Micklefield Jn to Church Fenton North Jn
LN904	Hambleton South Jn to Hambleton West Jn
LN906	Hambleton East Jn to Hambleton North Jn
LN908	Selby West Jn to Selby Canal Jn
LN910	Temple Hirst Jn to Selby South Jn
LN912	Thorne Jn to Gilberdyke Jn
LN914	Hull to Seamer West Jn
LN916	Hessle Road Jn to Saltend
LN918	Springbank North Jn to Walton Street Jn
LN920	Anlaby Road Jn to West Parade North Jn
LN922	Whitehall West Jn to Hellifield South Jn
LN924	Apperley Jn to Ilkley
LN926	Dockfield Jn to Esholt Jn
LN928	ShIPLEY East Jn to Bradford Forster Square
LN930	Skipton Middle Jn to Rylstone
LN932	ShIPLEY South Jn to ShIPLEY West Jn

1.2 Sectional Appendices and Rule Book

1.2.1 Sectional Appendix

The Sectional Appendix to the Working Timetable and Books of Rules and Regulations shall be used.

The Sectional Appendix is the sole source of information regarding the following:

Electrification limits refer to relevant Table 'A'

Permissive Working refer to relevant Table 'A', then see below.

Route Clearance refer to 'tab' associated with relevant Table 'A'

To identify the type of Permissive Working that applies at a given location refer to the appropriate Sectional Appendix Table A for that location. If there is authority for Permissive Working, this will appear in the Signalling and Remarks. There are different authorities that depend upon the signalling and layout of the location. The following list identifies the types of Permissive Working that will appear in the Sectional Appendix.

Type	Description
PP	Permissive Working – full use for class 1, 2, 3 ECS, 5, 9 and 0 trains
PP – A	Permissive Working – Attaching and Detaching use only for class 1, 2, 3 ECS, 5, 9 and 0 trains
PP – C	Permissive Working – Contingency use only for class 1, 2, 3 ECS, 5, 9 and 0 trains
PP – S	Permissive Working – Platform Sharing use only for class 1, 2, 3 ECS, 5, 9 and 0 trains
PF	Permissive Working for class 3 to 8 and 0 trains

Source: Sectional Appendix – General Instructions – National – Explanation of Table A terms and symbols

1.2.2 Rule Book

The following Modules of the Rule Book GE/RT8000 affects all sections unless specified. The sections listed affect railway operations and train movements. The listed section does not apply to Train Planning directly, but its application will affect how trains operate, and it is for that reason the item appears here.

RULE BOOK MODULE	SECTION	NOTES
G1 General safety responsibilities and personal track safety for non-track workers	5.5 Using the phonetic alphabet;	Operational principles
OTM Working of on-track machines (OTM)	2.2 Before starting a journey	TTPR Section 4.6
	5.6 Carrying out a running brake test	TTPR Section 5.1.2
P1 Single line working	6.5 Warning anyone working on or near the line used for single line working	When planning Single Line Working
	9.3 Right-direction movements	
	9.4 Wrong-direction movements	
S1 Signals and indicators controlling train movements		Operational principles
S2 Observing and obeying fixed signals	3.1 Passenger train at a position-light, shunt-ahead or shunting signal	Operational principles
SP Speeds	2.4 Differential permissible speed indicators	TTPR Section 5.1.2
	2.5 Permissible speed indicators with letters	TTPR Section 5.1.2
	2.6 Enhanced permissible	TTPR Section 5.1.2

RULE BOOK MODULE	SECTION	NOTES
	speed (EPS) indicators	
T11 Movement of engineering trains and on-track plant under T3 arrangements	3 Movements entering the possession	When planning trains entering possessions
	7 Instructing the driver or machine controller	When planning trains entering possessions
TW1 Preparation and movement of trains General	7.1 Authority and arrangements for movements (Hauling dead traction units)	Operational principles
TW2 Preparation and movement of multiple-unit passenger trains	6.5 Carrying out a running brake test	TTPR Section 5.1.2
TW3 Preparation and movement of locomotive hauled trains (including HSTs, push-pull, postal, parcels)	2.1 Locomotives running light or hauling trains (Maximum speed of);	TTPR Section 5.1.2
	2.2 Maximum permitted speed of locomotive-hauled trains	TTPR Section 5.1.2
	2.3 Electric-traction speed restrictions	TTPR Section 5.1.2
	3.16 Carrying out a running brake test	TTPR Section 5.1.2
	Section 14.1 Working trains with locomotives at both ends, when this type of working is permitted	Operational principles
Rule Book Handbook 5 Handsignalling Duties	Section 5.2 Entrance signal	When planning Temporary Block Working (TBW)
	5.3 Exit signal	When planning Temporary Block Working (TBW)
	5.4 Where TBW is divided into two sections	When planning Temporary Block Working (TBW)

1.3 Definitions

The list below is not an exhaustive one but is intended to give readers an understanding of some of the terminology as used for the purposes of this document.

If any term in Timetable Planning Rules is unclear please contact the compiler on the telephone number shown on the cover.

1.3.1 Train Classification

Classification	Description
1	Express passenger train; or Nominated postal or parcels train; or Breakdown or overhead line equipment train going to clear the line or returning from there (1Z99); or Traction unit going to assist a failed train (1Z99) Snow plough going to clear the line (1Z99)
2	Ordinary passenger train; or Breakdown or overhead line equipment train not going to clear the line (2Z99) Officers' special train (2Z01)
3	Freight train which can run at more than 75 mph; or A parcels train; or Empty coaching stock train if specially authorised
4	Freight train which can run up to 75 mph
5	Empty coaching stock train
6	Freight train which can run up to 60 mph
7	Freight train which can run up to 45 mph
8	Freight train which can run at, or is timed to run at, 35 mph or less
9	Thameslink services including to / from King's Cross
0	Light locomotive or locomotives

Source: The Rule Book GE/RT8000/TW1 Preparation and Movement of Trains General Section 2 Classification and speed of trains

Thameslink Services (Applicable from May 2018 Timetable)	
TID	Class 9 services (WTT)
9Jxx	Peterborough and Horsham via London Bridge and Redhill
9Sxx	Cambridge and Brighton via London Bridge and Quarry Lines
9Uxx	Cambridge and Maidstone East / Ashford via London Bridge and Swanley
9Yxx	Welwyn Garden City / Blackfriars and Sevenoaks via Catford and Swanley

1.3.2 Days of Operation

The following abbreviations are used to identify the day or days that a train operates.

Abbreviation	Description
M	Monday
T	Tuesday
W	Wednesday
Th	Thursday
F	Friday
S	Saturday
Su	Sunday
EWD	Every Week Day (Monday to Saturday)
Daily	Every day, systems will not accept this; there must be a separate entry for Sundays (Note – need to include reference to new ITPS processes).
Suffixes	
O	Adding this indicates that the train will run only on that day or those days shown
X	Adding this indicates that the train will not run on that day or those days shown
General	
BHX	Denotes that this train does not run on a bank holiday

1.3.3 Traction and Rolling Stock

Abbreviation	Description
15X	DMU classes 150/153/155/156/158/159
17X	DMU classes 170 and 175
22X	DMU classes 220/221/222
DMU	Any diesel multiple unit (excluding classes 180/220/221/222)
EMU	Any electric multiple unit
ECS	Empty Coaching Stock includes empty diesel and electric multiple units.
HST	Trains consisting of two Class 43 locomotives and Mk 3 passenger vehicles
LH	A passenger or parcels train hauled or propelled by one or more locomotives
LHCV	Locomotive hauled coaching vehicles
Power	Passenger stock equipped with power operated external doors

1.3.4 Line Codes

Abbreviation	Description
AD	Arrival/Departure Line
AL	Avoiding Line
BS	Leeds Line B
CHC	Copley Hill Chord
CL	Carriage Line
DBH	Down Barrow Hill
DBP	Down Back Platform at Welwyn Garden City
DCF	Down Cambridge Flyover
DF or DFL	Down Fast Line
DG	Two way Goods No.2
DGL	Down Goods Line
DH	Down Harrogate
DHL	Down Hendon Line
DL	Down Line
DM see below	Down Midland – Engine Sheet Jn or Leeds West Junction LN872
DM or DML	Down Main Line
DN	Leeds Line D – Non preferred route for ARS
DPV	Down Passenger Loop
DS or DSL	Down Slow Line
DSG	Down Scunthorpe Goods
DUG	Down and Up Goods
EL	Erewash Line
ESL	East Slow Line
FL	Fast Line – can be numbered eg FL1
GL	Goods Line
GSL	Goods and Slow Line
HS	Holding Siding
LSL	Leeds Line
ML	Main Line
NDS	Up Slow Line from Newcastle Platform 7 to Newcastle South Jn., then Down Slow Line to King Edward Bridge North Jn
NLI	North London Incline
NM	Up Slow Line from Newcastle Platform 7 to Newcastle South Jn., then Up Fast Line to King Edward Bridge North Jn
NNL	Normanton Line
NS	Up Slow Line from Newcastle Platform 7 to King Edward Bridge North Jn
PL	Platform Line
RCL	Reception Line
RRL	Reversing Line

Abbreviation	Description
SL	Slow Line – can be numbered eg SL1
SGL	Slow and Goods Line
TL	Through Line
UBH	Up Barrow Hill
UDB	Up and Down Blackwell
UDS	Up and Down Slow Line
UF or UFL	Up Fast Line
UGL	Up Goods Loop
UH	Up Harrogate
UHL	Up Hendon Line
UL	Up Line
UM see below	Up Midland – Leeds West Jn
UM or UML	Up Main Line
UPV	Up Passenger Loop or Up Broadholme Loop
US see below	Up Shipley/Up Sidings
US or USL	Up Slow Line
UWF	Up Welwyn Flyover
WS or WSL	Up West/West Slow Line
2WG	Two way Goods
WY	Peterborough West Yard

1.3.5 Activity and Other Codes

Abbreviation	Description
*	Suppression of traffic stop indicator
-D	Train stops to detach vehicles
-T	Train stops to attach and detach vehicles
-U	Train stops to attach vehicles
A	Train stops or shunts for other trains ahead or to pass only. Shows as an * in WTT
AE	Trains stops to attach/detach assisting locomotive.
BL	Train stops to attach or detach a banking locomotive
C	Train stops to change train crew
D	Train only stops to set down passengers. Shows as an s in NRT
E	Train stops for examination
G	NRT data to add
H	Notional Activity to prevent WTT column merge
HH	As H, were there is a third column involved
K	Passenger count point
KC	Ticket collection and examination point
KE	Ticket examination point
KF	Ticket examination point – 1 st Class only
KS	Selective ticket examination point
L	Train stops to change locomotives
N	Stop not advertised to the public
OP	Train stops for other operating reasons
OR	Train locomotive on rear of train
PR	Train propelling between points shown
R	Train stops when required. Shows as an x in NRT
RETB	Radio Electronic Token Block
RM	Trains stops for a reversing movement or driver to change ends
RR	Train stops to allow the locomotive to run-round its train
S	Trains for railway personnel only
T	Trains stops to pick up or set down passengers
TB	Train begins (Origin)
TF	Train finishes (Destination)

Abbreviation	Description
TS	Detail consist for TOPS Direct requested by Freight Operator
TW	Train stops to pick up or set down a staff, tablet or token on Single Lines. See Section 5.2
U	Train only stops to pick up passengers. Shows as a u in NRT
W	Train stops for watering of coaches
X	Train passes another train at crossing point on single line. See Section 5.2
x	Suppress running line information
	Force running line indication
	Force path and line indications
	Force path indication
#	Force stop with TW

Activity Codes – Notes

1. Any passenger train that stops at a location automatically generates a T Activity unless it is suppressed.
2. If an Activity is required that removes the 'passenger stop' Activity (T, D, U and R) from ITPS then the 'passenger stop' Activity must always appear in the first Activity field (e.g. T –D would be correct, –D T would not). This is because the National Rail Timetable (NRT) extract program only considers the first Activity field. If it does not find a 'passenger stop' Activity in the first field the time will not be extracted to appear in the NRT.
3. Up to 6 Activities may be shown for each event.
4. No two Activities may be duplicated at the same event.
5. At any one event, the following groups are mutually exclusive:
 - a) D, U, T, N, S, TW, OP.
 - b) –D, –U, –T.
 - c) TB, TF.
 - d) KC, KE.
6. N, R, G, D and U are only valid with Train Categories XC, XD, XI, XX, XZ, OO, OW, OL, BS, BR and blank (i.e. 'advertised' services).
7. K, KC, KE, KF, KS are only valid with Train Categories starting X or O.
8. If TF is present then none of K, KC, KE, KF, KS can be present.
9. Activity T indicates that a train stops to pick up and set down. This normally refers to passengers. Activity –T indicates that the train stops to attach and detach vehicles. At any location where a 'stop' time is shown, TPS or a similar system will assume a default Activity is required unless otherwise specified. These default Activities are as follows: T for trains with a Train Category starting in X or O, OP for trains with a Train Category starting in Z or E, and –T for all other trains (but see below). The default Activity will be generated when the upload file is created.
10. If Activities U, D, N, R, OP, S, TW, –U or –D are specified then this overrides the defaults and only the specified Activities will be included in the upload file (it is not necessary to use the * suppression code if these codes are present).
11. If a traffic Activity is NOT required at a 'stop' location with Activities other than U, D, N, R, OP, S, TW, –U or –D (e.g. at 'C' or 'L' stops) then the * must be input to the TPS or similar system train specification at that location to suppress –T or T. If the * is not added to indicate a non-traffic stop then T, –T or OP will be added to the upload file
12. If an Activity –T (only) is required on a train with a Category starting in X or O it is necessary to add a * to the schedule (to suppress 'T') and positively show –T in the Activity column.

2 Route Description

2.1 Planning Geography

Network Rail maintains the planning geography and issues it to Train Operators using the Bplan system. Bplan data is to be regarded as the master geography and it is the responsibility of Train Operators and nominated Network Rail users to ensure that data in their train planning systems reflects the master geography.

It is essential that all locations, times and full details such as platforms, running lines, activities, etc. comply fully with all of the following rules. Any Network Links used for buses only are to have running line defined as BUS. All data used by a specifier must be that supplied by Network Rail: use of estimated times added or amended locally will cause the trains concerned to fail validation.

In order to avoid the creation of unnecessary journey legs and associated point-to-point timings, all passing times must conform to these rules.

Locations in bold type are mandatory timing points.

Locations in normal type are non-mandatory timing points.

Locations in italic type are not timing points but are shown for reference purposes.

Line references shown in brackets e.g. (LN656) are only for reference purposes.

In the tables below, the following codes apply:

- F Only freight trains are timed here
- P Only passenger trains are timed here
- S Only stopping trains are timed here
- X Only trains crossing from one running line to another are timed here

LN101 LONDON KING'S CROSS TO SHAFTHOLME JUNCTION				
TIMING POINT	DOWN	UP	CODE	NOTES
King's Cross	A B C D			Platform detail must be shown A = No. 2 Fast (2F) B = No. 1 Fast (1F) C = No. 2 Slow (2S) D = No. 1 Slow (1S)
Belle Isle	SL FL	A B C D DCT UCT		A = No. 2 Fast (2F) B = No. 1 Fast (1F) C = No. 2 Slow (2S) D = No. 1 Slow (1S) <i>To/from St Pancras Low Level – Please refer to East Midlands train Planning rules LN3214</i>
Copenhagen Junction	SL	NLI	X	
Holloway South Junction	FL SL GL	FL SL		Applicable from May 2018 Timetable For Thameslink services only
Finsbury Park	FL SL SL2	FL SL SL2		Platform detail must be shown <i>To/from Drayton Park – LN105</i> <i>To/from Highbury Vale Jn – LN110</i>
<i>Harringay Junction</i>				<i>To/from Harringay Park Jn – EA1370</i>
Harringay Up Rev Sdgs	–		S	
Harringay Signal K85		SL2	S	
Harringay	SL	SL SL2	S	
Harringay Signal K422		SL2	S	

LN101 LONDON KING'S CROSS TO SHAFTHOLME JUNCTION				
TIMING POINT	DOWN	UP	CODE	NOTES
Ferme Park Rec	CL SL2	SL2	S	
Hornsey Dn RS	–	–	S	
Hornsey Signal K440	SL2			
Hornsey EMUD	SL2	SL SL2	S	
Hornsey	SL SL2	SL SL2	S	
Hornsey Signal K453	SL2		S	
Hornsey Signal K451	CL		S	
Alexandra Palace	FL SL	FL SL SL2 CL		Platform details must be shown for stopping trains and non-stop via platforms
<i>Wood Green North Jn</i>				<i>To/from Hertford North – LN120</i>
Bounds Green TRSMD		–	S	
New Southgate	FL SL	FL SL	SX	
Oakleigh Park	FL SL	FL SL	S	
New Barnet	FL SL	FL SL	SX	
Hadley Wood	FL SL	FL SL	S	
Potters Bar	FL SL	FL SL		Platform detail must be shown
Brookmans Park	FL SL	FL SL	S	
Welham Green	SL	SL	S	
Marshmoor		FL	X	
Hatfield	FL SL	SL FL	SX	Trains routed UWF from Welwyn Garden City via Flyover are to be timed at Hatfield
Welwyn GC Rev Sdgs	–		S	
Welwyn Garden City	FL SL	FL SL UWF		Platform details must be shown for stopping trains and non-stop via platforms
Welwyn FD	FL SL	SL	S	
Welwyn Garden City Carriage Sdgs		–	S	
Digswell Junction	FL	SL	X	
Welwyn North	FL	FL	S	
Woolmer Green Junction	FL SL	FL		
Knebworth	FL SL	FL SL	S	
Langley Junction	SL	–	X	<i>To/from Hertford North – LN120</i>
Langley Redlands		–	S	
Stevenage	FL SL	FL SL DSL		Platform detail must be shown
Stevenage Signal K214		FL SL	S	Only used for ECS reversal
Hitchin	FL SL DCF	FL SL		Platform details must be shown for stopping trains and non-stop via platforms Trains to Line "DCF" not via Platform 2 to be shown as Platform "DFL"
<i>Cambridge Junction</i>				<i>To/from Royston – LN125</i>
Hitchin Dn Yd	SL		S	
Hitchin Signal K232		SL –	S	Reversing point on Down Slow
Hitchin Up Yd	–	SL –	S	
<i>Hitchin North Junction</i>				<i>To Hitchin East Junction – LN126</i>
Cadwell		FL	X	Trains crossing to Fast Line
Arlesey	SL	SL	S	
Biggleswade Signal K235	FL SL		S	Reversing point on Up Slow
Biggleswade Plasmor		–	S	
Biggleswade	FL SL	FL SL		Platform details must be shown
Sandy	FL SL	FL SL		Platform details must be shown for stopping

LN101 LONDON KING'S CROSS TO SHAFTHOLME JUNCTION				
TIMING POINT	DOWN	UP	CODE	NOTES
				trains and non-stop via platforms
St Neots	FL SL	FL SL	SX	Platform detail must be shown for trains calling at St Neots DSL to UFL and DFL to USL or UFL moves not permitted at St Neots
Huntingdon Signal P33	–		S	Reversing point on Up Slow
Huntingdon	FL SL	FL SL		Platform details must be shown for stopping trains and non-stop via platforms
Huntingdon Signal P40		FL SL	S	
Conington Loop	–	FL		
Conington South Jn	SL	FL SL		Mandatory timing point in the Up direction
Holme Junction	FL			Mandatory timing point in the Down direction
Fletton Junction	SL	FL	X	
Peterborough Nene CHS	–		S	
<i>Crescent Junction</i>				<i>To/from Peterborough East Jn – LN135</i>
Peterborough	FL SL USL -	FL SL GL DSL -		Platform detail must be shown
Spital Junction South (P458/P79)	SDA SUD SHL –	–	X	Line code SDA/SUD/SHL to Eastfield Jn Blank “ – ” line code to Spital Sidings
Peterborough LIP	SHL	–	S	
Signal P78		–	S	Reversing point on Down Fast
Signal P76		–	S	Reversing point on Down Slow
Peterborough Spital Sidings	–	–	S	Thameslink Stabling Sidings
Peterborough Westwood Sdgs	–	–	S	
Peterborough Eastfield Junction	GL	SDA SUD SHL	X	All trains not on Fast, Slow or Stamford lines to be timed here
Signal E44		–	S	Reversing movement
Peterborough West Yard	–	–	S	
Peterborough Maint. Shed		–	S	
Peterborough Washer Road	–	–	S	
Peterborough Virtual Quarry	–	–	S	
New England North Signal P479	GL		S	
New England North Jn	FL SL	FL SL GL	X	
Werrington Junction	–	SL	X	<i>To/from Spalding – LN170</i>
Tallington Junction	FL SL	FL SL		
Tallington Redland Aggs		–	S	
Stoke Junction	–	FL SL		
Highdyke Jn		–	X	
D1283 G.P.S.	–		S	<i>Upside to Downside shunt moves</i>
Grantham	–	– SL		Platform detail must be shown
Nottingham Branch Jn	–	–		Trains on up/down slow line <i>To/from Allington West Jn – LN195</i>
Claypole Loops	–	–		

Newark North Gate	–	–		Platform detail must be shown
Signal D83	–	–	S	
<i>Newark Crossing South Jn</i>				<i>To/from Newark Crossing East Jn – LN210</i>
Newark Flat Crossing	–	–		
Carlton Loops	–	–	S	<i>For train planning purposes, this location is known as Carlton On Trent Loop</i>
D1341 G.P.S.	–		S	P1 to P2 shunt/access to Worksop line
Retford	– SL	–		Platform detail must be shown for stopping trains and non-stopping via platform lines
<i>Retford Western Jn</i>				<i>To/from Thrumpton West Jn – LN748</i>
Retford Signal D156		–	S	
Babworth Loop	–		S	Bi-directional loop, down slow after Retford
Ranskill Loops	–	–	S	
Loversall Carr Jn	WSL –	–		<i>To/From Flyover West Jn – LN160</i>
<i>Loversall Jn</i>				<i>From Flyover East Jn – LN155</i>
Black Carr Jn	ESL	ESL –		Mandatory East Slow Lines <i>To/from Bessacarr Jn – LN220</i>
Potteric Carr Jn	– ESL	ESL –		Mandatory East Slow Lines <i>To/from Low Ellers Curve Jn – LN764</i>
Doncaster Railport		–	S	
Doncaster Up Decoy	ESL	–	S	
Doncaster Sig D254		ESL	S	Crew relief point on Up East Slow
Decoy North Junction	DFL DS1 DS2 DR –		X	<i>To/from Decoy South Jn – LN150</i>
Doncaster Signal D249	–		S	
Doncaster Belmont Down Yard	–	–	S	
Bridge Junction	–	–		<i>To/from St James Jn – LN832</i> Mandatory West Slow Lines
<i>South Yorkshire Junction</i>				<i>To/from Hexthorpe Jn – LN826</i>
Doncaster	–	– FL ESL WSL		Platform detail must be shown
Doncaster West Yard	–	–	S	
Marshgate Junction	–	–	S	<i>To/from Leeds – LN836</i> <i>To/from Hull/Cleethorpes – LN752</i>
Arksey Loop	–		S	
Shaftholme Junction	–	–		<i>To/from Temple Hirst Jn LN600</i> <i>To/from Knottingley – LN889</i>

LN105 MOORGATE TO FINSBURY PARK JUNCTION

TIMING POINT	DOWN	UP	CODE	NOTES
Moorgate	–			Platform details must be shown
Old Street	–	–	S	
Essex Road	–	–	S	
Highbury and Islington	–	–	S	Platform details must be shown
Drayton Park	–	–		
Finsbury Park	FL SL SL2			<i>To/from Alexandra Palace – LN101</i>

LN110 CANONBURY WEST JUNCTION TO FINSBURY PARK JUNCTION				
TIMING POINT	DOWN	UP	CODE	NOTES
Canonbury West Jn	–	–		<i>To/from North London Line – EA1320</i>
Highbury Vale Jn	–	–		
Finsbury Park	SL SL2	–		<i>To/from Alexandra Palace – LN101</i>

LN115 COPENHAGEN JUNCTION TO CAMDEN ROAD CENTRAL JUNCTION				
TIMING POINT	DOWN	UP	CODE	NOTES
Copenhagen Junction	–	SL	X	<i>To/From Alexandra Palace – LN101</i>
York Way North Junction	–	–		<i>To/from Silo Curve Jn – SO410A</i>
Camden Road Incline Junction				<i>To/from Cedar Jn – SO420</i>
Camden Road Central Junction	–	–	X	<i>To/from North London Line – EA1320</i>

LN120 WOOD GREEN NORTH JUNCTION TO LANGLEY JUNCTION (VIA HERTFORD)				
TIMING POINT	DOWN	UP	CODE	NOTES
<i>Wood Green North Junction</i>				<i>To/from King's Cross – LN101</i>
Bounds Green T&RSMD		–	S	
Bowes Park	–	–	S	
Bowes Park RRL		–	S	
Palmers Green	–	–	S	
Winchmore Hill	–	–	S	
Grange Park	–	–	S	
Enfield Chase	–	–	S	
Gordon Hill	–	–		Platform details must be shown
Crews Hill	–	–	S	
Cuffley	–	–	S	
Bayford	–	–	S	
Hertford North CHS	–	–	S	
Hertford North DCS	–	–	S	
Hertford North	–	–		Platform details must be shown
Molewood Junction	–	–	X	
Watton at Stone	–	–	S	
Bragbury Junction	–	–	X	
Langley South Junction	–	–	X	
Langley Junction	SL	DL		<i>To/from Stevenage – LN101</i>

LN125 HITCHIN CAMBRIDGE JUNCTION TO ROYSTON (INCLUSIVE)				
TIMING POINT	DOWN	UP	CODE	NOTES
Hitchin	DCF	–		<i>To/from Stevenage – LN101</i>
Hitchin Up Yard	–	–	S	
Hitchin Signal K228		–	S	Reversing point on Up Slow
<i>Hitchin East Junction</i>				<i>From Hitchin – LN126</i>
Letchworth Garden City	–	–		
Letchworth CSD	–	–	S	Trains into Letchworth CSD to/from the station must run via Letchworth A/D Line and reverse at Letchworth CS Reception

LN125 HITCHIN CAMBRIDGE JUNCTION TO ROYSTON (INCLUSIVE)				
TIMING POINT	DOWN	UP	CODE	NOTES
Letchworth A/D Line	–	–	S	
Letchworth CS Reception	–	–	S X	
Baldock	–	–	S	
Ashwell and Morden	–	–	S	
Royston	–	–		Platform details must be shown <i>To/from Shepreth Branch Jn – EA1230</i>

LN126 HITCHIN NORTH JUNCTION TO HITCHIN EAST JUNCTION				
TIMING POINT	DOWN	UP	CODE	NOTES
<i>Hitchin North Junction</i>				<i>To/from King's Cross LN101</i>
<i>Hitchin East Junction</i>				<i>To Cambridge LN125</i>

LN135 KING'S DYKE TO CRESCENT JUNCTION				
TIMING POINT	DOWN	UP	CODE	NOTES
<i>King's Dyke</i>				<i>To/from Whittlesea – EA1560</i>
Peterborough East Junction	– GL	–		
<i>Crescent Jn</i>				<i>To/from Peterborough – LN101</i>

LN147 HELPSTON JUNCTION TO UFFINGTON				
TIMING POINT	DOWN	UP	CODE	NOTES
Helpston Junction				To/from Peterborough LN101
Uffington				To/from LN3615

LN150 FLYOVER EAST JUNCTION TO DECOY NORTH JUNCTION				
TIMING POINT	DOWN	UP	CODE	NOTES
<i>Flyover East Junction</i>				<i>To/from Gainsborough Trent Jn – LN170 To Loversall Jn – LN155. Only accessible in the Up direction from the Down Lincoln</i>
<i>Flyover West Junction</i>				<i>To/from Loversall Carr Jn – LN160</i>
Decoy South Junction	–	– DLF		<i>To/from St Catherine's Jn – LN762</i>
Doncaster Down Decoy	–	–	S	
Doncaster RMT	–	–	S	
Decoy North Junction	DFL DS1 DS2 DR –	–		Mandatory West Slow lines.

LN155 FLYOVER EAST JUNCTION TO LOVERSALL JUNCTION (UP LOVERSALL CURVE)

TIMING POINT	DOWN	UP	CODE	NOTES
<i>Flyover East Junction</i>				<i>From Flyover West Jn – LN150. Line is Up direction only</i>
<i>Loversall Junction</i>				<i>To Loversall Carr Jn – LN101</i>

LN160 LOVERSALL CARR JUNCTION TO FLYOVER WEST JUNCTION

TIMING POINT	DOWN	UP	CODE	NOTES
Loversall Carr Junction	–			<i>From Retford – LN101</i>
Rossington Colliery Junction	–	–	X	<i>To/from Rossington Colliery – LN235</i>
<i>Flyover West Junction</i>				<i>To/from Decoy North Jn – LN150</i>

LN165 HARRINGAY PARK JUNCTION TO HARRINGAY JUNCTION

TIMING POINT	DOWN	UP	CODE	NOTES
Harringay Park Junction	–	–		<i>To/from Upper Holloway – EA1370</i>
<i>Harringay Junction</i>				<i>To Hornsey – LN101</i>

LN170 WERRINGTON JUNCTION TO FLYOVER EAST JUNCTION (VIA LINCOLN)

TIMING POINT	DOWN	UP	CODE	NOTES
Werrington Junction	–	SL		<i>To/from Peterborough – LN101</i>
Spalding	–	–		
Quadrant Signal WS7071		–		
Quadrant Signal WS7070	–			
Sleaford South Junction	DA	–		<i>To/from Sleaford East Jn – LN175</i>
Sleaford North Junction	–	UA		<i>To/from Sleaford West Jn – LN180</i>
Ruskington	–	–	S	
Metheringham	–	–		
Pelham Street Junction	–	–		<i>To/from Langworth S.B. – LN200</i>
Lincoln Central	–	–		Platform details must be shown
East Holmes Jn	SL FL	–	X	
West Holmes Junction	–	SL FL		<i>To/from Boultham Jn – LN206</i>
Pyewipe Junction	–	–	X F	<i>To/from Boultham Junction – LN215</i>
Saxilby	–	–		
Gainsborough Lea Road	–	–		
Gainsborough Trent Junction	–	–		<i>To/from Gainsborough Central – LN736</i> <i>To/from Clarborough Jn – LN736</i>
Beckingham Loops	–	–	S	
Bessacarr Junction	–	–		<i>To/from Black Carr Jn – LN150</i>
<i>Flyover East Junction</i>				<i>To/from Decoy South Jn – LN150</i>

LN175 SLEAFORD SOUTH JUNCTION TO SLEAFORD EAST JUNCTION				
TIMING POINT	DOWN	UP	CODE	NOTES
Sleaford South Jn	-	-		<i>To/From Spalding – LN170</i>
<i>Sleaford East Jn</i>				<i>To/from Sleaford – LN185</i>

LN180 SLEAFORD WEST JUNCTION TO SLEAFORD NORTH JUNCTION				
TIMING POINT	DOWN	UP	CODE	NOTES
<i>Sleaford West Jn</i>				<i>To/from Sleaford Station – LN185</i>
Sleaford North Jn	-	-		<i>To/from Metheringham – LN170</i>

LN185 ALLINGTON WEST JUNCTION TO SKEGNESS				
TIMING POINT	DOWN	UP	CODE	NOTES
Allington West Jn	-	-		<i>To/from Bottesford West Jn – LN3625. Refer to East Midlands Timetable Planning Rules</i>
Allington North Jn	-	-	X	<i>To/from Allington East Jn – LN190</i>
Ancaster	-	-	S	
Rauceby	-	-		
<i>Sleaford West Junction</i>				<i>To/from Sleaford North Jn – LN180</i>
Sleaford	-	-		Platform detail must be shown <i>To/from Sleaford North Jn – LN180</i>
<i>Sleaford East Junction</i>				<i>To/from Sleaford South Jn – LN175</i>
Heckington	-	-		
Swineshead	-	-	S	
Hubberts Bridge	-	-		
<i>Sleaford Jn</i>				
Boston Docks	-	-	S	
Boston	-	-		
<i>Grand Sluice Jn</i>				
Sibsey SB	-	-		
Bellwater Junction SB	-	-		
Thorpe Culvert	-	-	S	
Wainfleet	-	-		
Havenhouse	-	-	S	
Skegness		-		Platform detail must be shown

LN190 ALLINGTON EAST JUNCTION TO ALLINGTON NORTH JUNCTION (ALLINGTON CHORD)				
TIMING POINT	DOWN	UP	CODE	NOTES
Allington East Junction	-	-	X	<i>To/from Grantham Nottingham Branch Jn – LN195</i>
Allington North Junction	-	-	X	<i>To/from Rauceby – LN185</i>

LN195 GRANTHAM NOTTINGHAM BRANCH JUNCTION TO ALLINGTON WEST JN (INCLUSIVE)

TIMING POINT	DOWN	UP	CODE	NOTES
Grantham Nottingham Branch Jn	–	–		To/from Grantham – LN101
Allington East Jn	–	–	X	To/from Allington North Jn – LN190
Allington West Junction	–	–		To/from Rauceby – LN185 To/from Bottesford West Jn – LN3635. Refer to East Midlands Timetable Planning Rules

LN200 WRABBY JUNCTION TO PELHAM STREET JUNCTION

TIMING POINT	DOWN	UP	CODE	NOTES
Wrawby Junction	–	–		To/from Barnetby LN736
Holton-le-Moor	–	–		
Market Rasen	–	–	S	
Wickenby SB	–	–		
Langworth SB	–	–		
Welton BP	–	–	S	Petroleum sidings
Pelham Street Junction	–	–		To/from Lincoln Central LN170

LN206 NEWARK FLAT CROSSING (INCLUSIVE) TO WEST HOLMES JUNCTION

TIMING POINT	DOWN	UP	CODE	NOTES
Newark Flat Crossing	–	–		To/from Newark Castle – LN3625. Refer to East Midlands Timetable Planning Rules
Newark Crossing East Junction	–	–		To/from Newark North Gate – LN210
Collingham	–	–	S	
Swinderby	–	–	S	
Hykeham	–	–	S	
Boultham Junction	–	–		To/from Pyewipe Jn – LN215
West Holmes Jn	–	–		To/from Lincoln – LN170

LN210 NEWARK CROSSING CURVE LINE

TIMING POINT	DOWN	UP	CODE	NOTES
<i>Newark Crossing South Jn</i>				To/from Newark North Gate – LN101
Newark Crossing East Jn				To/from Boultham – LN206
Newark Crossing East Jn				

LN215 BOULTHAM JUNCTION TO PYEWIPE JUNCTION

TIMING POINT	DOWN	UP	CODE	NOTES
Boultham Jn	–	–		To/from Newark Crossing East Junction – LN206
Pyewipe Jn	–	–	X	To/from Saxilby – LN170

LN220 BESSACARR JUNCTION TO BLACK CARR JUNCTION				
TIMING POINT	DOWN	UP	CODE	NOTES
Bessacarr Jn	–	–		<i>To/from Gainsborough Trent Jn – LN170</i>
Black Carr Jn	ESL	–		<i>To/from Doncaster – LN101</i>

LN235 ROSSINGTON COLLIERY BRANCH				
TIMING POINT	DOWN	UP	CODE	NOTES
Rossington Colliery	–	–		
Rossington Colliery Jn	–	–	X	<i>To/from Flyover West Jn – LN160</i>

LN600 SHAFTHOLME JUNCTION TO RESTON GSP				
TIMING POINT	DOWN	UP	CODE	NOTES
Shaftholme Junction	–	–		<i>To/from Haywood Jn– LN889 To/from Doncaster – LN101</i>
Joan Croft Junction	–	–	X	<i>To/from Applehurst Jn – LN844</i>
Doncaster Signal D866		–	S	<i>For trains that reverse to propel into Heck Plasmor PS</i>
Heck Plasmor PS		–	S	
Temple Hirst Junction	–	–		<i>To/from Selby – LN910</i>
Hambleton South Junction	–	–	X	<i>To/from Hambleton West Junction – LN904</i>
Hambleton North Junction	–	–		<i>To/from Hambleton East Junction – LN906</i>
Colton Junction	– LSL NNL	– LSL NNL		Trains To/from Hambleton Junction to be – (blank line) unless crossing. Trains from Church Fenton be LSL or NNL <i>To/from Church Fenton – LN854</i>
Colton North Junction	LSL	NNL	X	
York Holgate Sidings <i>Holgate Junction</i>	–	LSL	S	<i>To/from Skelton Jn via Slow lines – LN618</i>
York	– AL	LSL NNL		Platform detail must be shown
York NRM	–		S	
York LIP	–	–	S	
York TPE	–		S	
Skelton Junction	FL SL	– DL SL		DL only to be used in Up direction for trains from Poppleton or Slow lines <i>To/from Poppleton – LN838 To/from Holgate Jn via Slow Lines – LN618</i>
Skelton Bridge Junction	FL SL	FL SL	X	
Tollerton	FL SL	FL SL		
Thirsk	FL SL	FL SL		
Longlands Junction	–	SL	X	<i>To/from Boroughbridge Road LC – LN627</i>
Northallerton	–	– SL		
<i>Northallerton High Junction</i>				<i>To/from Northallerton East Jn – LN626</i>
Northallerton Reversing Line		–	S	<i>To/from Castle Hills – LN624</i>
Darlington Dn Pass Loop	–		S	
<i>Darlington South Junction</i>				<i>To/from Eaglescliffe – LN631</i>
Darlington	–	–		Platform or Loop detail must be shown
Darlington Up Sidings	–	–	S	
<i>Darlington North Junction</i>				<i>To/from Heighington – LN678</i>

LN600 SHAFTHOLME JUNCTION TO RESTON GSP				
TIMING POINT	DOWN	UP	CODE	NOTES
Ferryhill South Junction	– SL	–		<i>To/from Norton West Junction – LN646</i>
Ferryhill Old Yard T.C.	–	–	S	
Ferryhill Up Goods Loop	–	–	S	
Thrislington	–	–	S	
<i>Kelloe Access Line Junction</i>				
Tursdale Junction	–	– SL		
Durham	–	–		
Durham Sig T358		–	S	
Durham Sig T357	–	–	S	
Chester-le-Street	–	–	S	
Birtley Junction	– SL	–		
Tyne Yard Sig T176		–	S	
Tyne S.S.	–	–	S	
Tyne Yard Sig T193	–	–	S	
Low Fell Junction	–	– SL	X	<i>To/from Norwood Jn – LN684</i>
King Edward Bridge South Junction	– FL SL UML	–		<i>To/from Norwood Jn – LN682</i> <i>To/from King Edward Bridge East Jn – LN676</i>
King Edward Bridge North Junction		– SL		Slow line only <i>To/from King Edward Bridge East Jn – LN620</i>
<i>Newcastle West Junction</i>				<i>To/from Forth Banks – LN622</i>
Newcastle	– DML SL UML	– SL DSL ML DML		Platform detail must be shown Standard line designations These line designations only to be used when departing from Platform 7 via Platform 8
<i>Newcastle East Junction</i>				<i>To/From High Level Bridge Junction – LN627</i>
Manors	– ML	– SL	S	
Heaton South Junction	– GL	– DML SL UML		
Heaton TRSMD		–	S	
Heaton North Junction	–	– GL	X	
Benton North Junction	–	–	X	<i>To/from Newsham L.C. – LN694</i>
Cramlington	–	–	S	
Morpeth	– GL	–		<i>To/from Hepscoth Jn – LN696</i>
Morpeth Loop				
Morpeth North Junction	–	–	X	<i>To/from Hepscoth Jn – LN694</i>
Pegswood	–	–	S	
Butterwell Junction	–	–	X	<i>To/from Butterwell – LN700</i>
Widdrington	–	–	S	
Chevington Loops	–	–	S	
Acklington	–	–	S	
Wooden Gate Junction	–	–	S	
Alnmouth for Alnwick	–	–		
Chathill	–	–	S	
Belford	–	–		
Crag Mill Loops	–	–	S	
Tweedmouth FD	–	–	S	
Berwick upon Tweed	–	–		Platform detail must be shown
Berwick Goods Loops	–	–	S	

LN600 SHAFTHOLME JUNCTION TO RESTON GSP				
TIMING POINT	DOWN	UP	CODE	NOTES
Signal EG403	–			<i>Down trains To Reston – SC147</i>
Signal EG402		–		<i>Up trains From Reston – SC147</i>
<i>Reston GSP</i>				

LN618 HOLGATE JUNCTION TO SKELTON JUNCTION				
TIMING POINT	DOWN	UP	CODE	NOTES
<i>Holgate Junction</i>				<i>To/from Colton North Jn – LN600</i>
York Yard South Junction	–	LSL –		Trains to Holgate Sidings/Loop to be – (blank line). Trains to Colton Junction/ Colton North Junction must be LSL.
York Yard South	–	–	S	
York GR Shed	–	–	S	
York NRM Annexe (Warehouse Yard)	–	–	S	
York Engineers' Yard	–	–	S	
York Yard North	–	–	S	
Skelton Junction	FL SL	SL		<i>To/from Skelton Bridge Jn – LN600</i> <i>To/from Poppleton – LN838</i>

LN620 KING EDWARD BRIDGE EAST JUNCTION TO KING EDWARD BRIDGE NORTH JUNCTION				
TIMING POINT	DOWN	UP	CODE	NOTES
King Edward Bridge East Junction	–	–		<i>To/from Greensfield Jn – LN676</i>
King Edward Bridge North Junction	USL	–		<i>To/from Newcastle – LN600</i>

LN622 FORTH BRANCH				
TIMING POINT	DOWN	UP	CODE	NOTES
<i>Newcastle West Junction</i>				<i>To/from Newcastle – LN600</i>
Forth Banks		–		

LN624 NORTHALLERTON CASTLE HILLS JUNCTION TO CASTLE HILLS WEST GF				
TIMING POINT	DOWN	UP	CODE	NOTES
<i>Castle Hills Junction</i>				<i>To/from Northallerton – LN600</i>
Castle Hills Loop	–	–	S	
<i>Castle Hills West GF</i>				<i>To/from Wensleydale Railway</i>

LN626 NORTHALLERTON HIGH JUNCTION TO NORTHALLERTON EAST JUNCTION

TIMING POINT	DOWN	UP	CODE	NOTES
<i>Northallerton High Junction</i>				<i>To/from Thirsk – LN600</i>
Northallerton Signal Y478		–	S	
Northallerton East Jn	–	–		<i>To/from Yarm/Eaglescliffe LN627</i>

LN627 LONGLANDS JUNCTION TO NEWCASTLE EAST JUNCTION VIA THE COAST

TIMING POINT	DOWN	UP	CODE	NOTES
Longlands Junction	–	– SL		<i>To/from Thirsk – LN600</i>
Boroughbridge Road LC	–	–		
Northallerton East Jn.	–	–		<i>To/from Northallerton High Jn – LN626</i>
Yarm	–	–	S	
Eaglescliffe	–	–		<i>To/from Dinsdale – LN631</i>
Stockton Cut Junction	–	–		<i>To/from Bowesfield Jn – LN632</i>
Hartburn Junction	–	–		<i>To/from Bowesfield Jn – LN644</i>
Stockton Sig B907	–		S	Reversing point on Up line
Stockton TJ Thompson	–	–	S	
Stockton	–	–	P	
Norton South Junction	–	–		<i>To/from Norton West Jn – LN646</i>
Norton East Junction	–	–	X	<i>To/from Norton West Jn – LN648</i>
Billingham Junction	–	–		<i>To/from Belasis Lane – LN652</i>
Billingham	–	–	S	
Greatham SB	–	–		
Hartlepool South Works		–	S	
Seaton Snook Junction	–	–	X	<i>To/from Seaton on Tees Branch – LN656</i>
Seaton Carew	–	–	S	
Cliffe House DGL	–		S	UGL Out of use
Hartlepool	–	–		Platform detail must be shown
Horden Sig 7137	–			
Horden Sig 7150		–		
Hartlepool Docks		–	S	
Seaham Harbour	–		S	
Seaham	–	–		
Ryhope Grange Sidings	–		S	
Ryhope Grange Junction	–	–		<i>To/from Hendon – LN662</i>
Siding 1		–	S	

LN627 LONGLANDS JUNCTION TO NEWCASTLE EAST JUNCTION VIA THE COAST				
TIMING POINT	DOWN	UP	CODE	NOTES
<i>Sunderland South Junction</i>				<i>To/from South Hylton – LN628</i>
Sunderland	–	– DSH		Platform detail must be shown DSH for trains terminating at Park Lane
St Peter's	–	–	S	
Stadium of Light	–	–	S	
Seaburn	–	–	S	
East Boldon	–	–	S	
East Boldon Up Loop		–	S	
Boldon East Junction	–	–	X	<i>To/from Boldon North Jn – LN666</i>
Brockley Whins	–	–	P	
Boldon West Junction	–	–	F	<i>To/from Boldon North Jn – LN666</i>
Fellgate	–	–	S	
Pelaw Metro Jn	–	–	X	<i>Tyne & Wear Metro Trains only To/from Pelaw South Junction – LN629 To/from Pelaw North Junction – LN630</i>
Pelaw Junction	–	–		<i>To/from Jarrow – LN670 To/from Wardley – LN672</i>
Pelaw Goods Loop	–	–	S	
Heworth	–	–	S	
Tyneside CFD	–	–	S	Presently out of use
Park Lane Jn	–	–		<i>To/from Greensfield Jn – LN676</i>
High Level Bridge Junction	–	–		<i>To/from Greensfield Junction – LN674</i>
High Level Bridge Central Jn	–	–		
<i>Newcastle East Junction</i>				<i>To/from Newcastle – LN600</i>

LN628 SOUTH HYLTON TO SUNDERLAND SOUTH JUNCTION				
TIMING POINT	DOWN	UP	CODE	NOTES
South Hylton	–			
Pallion	–	–	S	
Millfield	–	–	S	
University (Sunderland)	–	–	S	
Sunderland Park Lane	–	–	S	
Siding 2	–		S	For train planning purposes, this location is known as Sunderland Burdon Dock Sdg
<i>Sunderland South Junction</i>				<i>To/from Sunderland – LN627</i>

LN629 PELAW METRO JUNCTION TO PELAW SOUTH JUNCTION				
TIMING POINT	DOWN	UP	CODE	NOTES
Pelaw Metro Junction	–		X	Down direction only <i>From Sunderland – LN627</i>
<i>Pelaw South Junction</i>				<i>To Tyne & Wear Metro</i>

LN630 PELAW NORTH JUNCTION TO PELAW METRO JUNCTION				
TIMING POINT	DOWN	UP	CODE	NOTES
<i>Pelaw North Junction</i>				<i>From Tyne & Wear Metro</i>
Pelaw Metro Junction		–	X	Up direction only <i>To Sunderland – LN627</i>

LN631 DARLINGTON SOUTH JUNCTION TO EAGLESCLIFFE SOUTH JUNCTION				
TIMING POINT	DOWN	UP	CODE	NOTES
<i>Darlington South Jn</i>				<i>To/from Darlington – LN600</i>
Dinsdale	–	–		
Tees-side Airport	–	–	S	
Allens West	–	–	S	
<i>Eaglescliffe South Junction</i>				<i>To/from Northallerton or Boroughbridge L.C. – LN627</i>

LN632 STOCKTON CUT JUNCTION TO SALTBURN				
TIMING POINT	DOWN	UP	CODE	NOTES
Stockton Cut Junction	–	–		<i>To/from Eaglescliffe – LN627</i>
Bowesfield Junction	–	–		<i>To/from Hartburn Jn – LN644</i>
Thornaby East Junction	– ML GL	–	F	
Thornaby	–	–	P	
Thornaby No.1		–	S	
Tees NY	–	–	S	
Newport East Jn	ML GL	– FL GL1 GL2	F	
Middlesbrough Goods Yard		–	S	
Middlesbrough Dawson's	–	–	S	
Middlesbrough West Dock	–		S	
Middlesbrough	– ML GL	– ML GL		Platform detail must be shown
Middlesbrough Carriage Sdgs		–	S	
Guisborough Junction	–	–	P	<i>To/from Nunthorpe – LN634</i>
Whitehouse Jn	–	– ML GL	F	
South Bank Jn	ML GL	–	F	
South Bank	–	–	S	
Beam Mill Junction	GL	GL	F	<i>To/from Lackenby – LN636</i>
Grangetown (Cleveland)	ML GL	ML GL	F	
Tees Dock		–	S	
Grangetown Junction	– ML	GL	X	
Shell Junction	–	ML GL	X	<i>To/from Wilton – LN638</i>
Redcar Ore Terminal Junction	–	–	X	
Redcar Bulk Terminal	–	–	S	
Redcar Mineral Terminal	–	–	S	
British Steel Redcar	–	–	S	
Redcar Central	–	–		
Redcar East	–	–	S	
Longbeck	–	–	S	
Marske	–	–	S	
Saltburn West Junction	–	–		<i>To/from Boulby – LN642</i>
Saltburn		–		Platform detail must be shown

LN634 GUISBOROUGH JUNCTION TO WHITBY				
TIMING POINT	DOWN	UP	CODE	NOTES
Guisborough Junction	–	–		<i>To/from Middlesbrough – LN632</i>
James Cook	–	–	S	
Marton	–	–	S	
Gypsy Lane	–	–	S	
Nunthorpe	–	–		Platform detail must be shown
Nunthorpe Signal N1	–	–	S	
Great Ayton	–	–	S	
Battersby	–	–		Train reverses – See Section 5.3
Kildale	–	–	S	
Commondale	–	–	S	
Castleton Moor	–	–	S	
Danby	–	–	S	
Lealholm	–	–	S	
Glaisdale	–	–		
Egton	–	–	S	
Grosmont	–	–	S	<i>To/from North Yorkshire Moors Railway</i>
Sleights	–	–	S	
Ruswarp	–	–	S	
Whitby		–		Platform detail must be shown

LN636 BEAM MILL JUNCTION TO SLAG ROAD (LACKENBY)				
TIMING POINT	DOWN	UP	CODE	NOTES
Beam Mill Junction	–	GL	F	<i>To/from Middlesbrough – LN632</i>
Slag Road LC	–	–		NR boundary <i>To/from Lackenby BSC</i>

LN638 GRANGETOWN SHELL JUNCTION TO CLEVELAND FREIGHTLINER TERMINAL (WILTON)				
TIMING POINT	DOWN	UP	CODE	NOTES
Shell Junction	–	ML GL	X	<i>To/from Grangetown – LN632</i>
<i>ICI Wilton Junction</i>				<i>To/from ICI Wilton Coal Terminal – LN640</i>
Wilton EFW Terminal	–	–	S	
Wilton FLT		–		

LN640 ICI WILTON COAL TERMINAL				
TIMING POINT	DOWN	UP	CODE	NOTES
<i>ICI Wilton Junction</i>				<i>To/from Shell Jn – LN638</i>
Wilton Coal Terminal		–		

LN642 SALT BURN WEST JUNCTION TO BOULBY POTASH MINE				
TIMING POINT	DOWN	UP	CODE	NOTES
Salburn West Junction	–	–		<i>To/from Redcar Central – LN632</i>
Crag Hall Signal Box	–	–		<i>Token Exchange Point</i>
Skinningrove BSC	–	–	S	
Boulby Potash Reception	–	–	S	
Boulby Mine Carlin How	–	–	S	

LN644 HARTBURN JUNCTION TO BOWESFIELD JUNCTION				
TIMING POINT	DOWN	UP	CODE	NOTES
Hartburn Junction	–	–		<i>To/from Stockton – LN627</i>
Bowesfield Junction	–	–		<i>To/from Thornaby – LN632</i>

LN646 NORTON-ON-TEES SOUTH TO FERRYHILL SOUTH JUNCTION				
TIMING POINT	DOWN	UP	CODE	NOTES
Norton South Jn	–	–		<i>To/from Stockton – LN627</i>
Norton West Jn	–	–		<i>To/from Norton East Jn – LN648</i>
Ferryhill South Jn	– SL	–		<i>To/from Darlington – LN600</i>

LN648 NORTON-ON-TEES WEST TO NORTON-ON-TEES EAST				
TIMING POINT	DOWN	UP	CODE	NOTES
Norton West Jn	–	–		<i>To/from Ferryhill South Jn – LN646</i>
Norton East Jn	–	–	X	<i>To/from Billingham – LN627</i>

LN652 BILLINGHAM JUNCTION TO SEAL SANDS STORAGE				
TIMING POINT	DOWN	UP	CODE	NOTES
Billingham Jn	–	–		<i>To/from Norton Jns – LN627</i>
Belasis Lane SB	–	–		<i>Trains to/from Phillips Loop direction Must stop for token exchange See 5.3</i>
Haverton Hill East Grid		–	S	
Port Clarence Sidings: Bells Bank		–	S	
Port Clarence Sidings: Petroplus			S	
Phillips Loop	–	–		<i>Must stop for ground frame operation see 5.3</i>
Port Clarence Refinery			S	
Port Clarence Phillip's		–	S	
North Tees Level Crossing				<i>Present end of route</i>
Seal Sands Branch Jn	–	–		Permanently Out of Use
Seal Sands Storage		–		Permanently Out of Use

LN656 SEATON-ON-TEES BRANCH				
TIMING POINT	DOWN	UP	CODE	NOTES
Seaton Snook Jn	–	–	X	<i>To/from Seaton Carew – LN627</i>
Hartlepool Power Station		–		

LN662 RYHOPE GRANGE JUNCTION TO HENDON (SUNDERLAND DOCKS)				
TIMING POINT	DOWN	UP	CODE	NOTES
Ryhope Grange Jn	–	–		<i>To/from Seaham – LN627</i>
Hendon	–	–		
Sunderland South Dock		–		

LN664 BOLDON EAST JUNCTION TO BOLDON NORTH JUNCTION				
TIMING POINT	DOWN	UP	CODE	NOTES
Boldon East Jn	–	–	X	<i>To/from Sunderland – LN627</i>
Boldon North Jn	–	–		<i>To/from Green Lane – LN666</i>

LN666 BOLDON WEST JUNCTION TO TYNE DOCK				
TIMING POINT	DOWN	UP	CODE	NOTES
Boldon West Junction	–	–		<i>To/from Pelaw – LN627</i>
Boldon North Junction	–	–		<i>To/from Boldon East Jn LN664</i>
Green Lane Junction	–	–		<i>Green Lane Junction and Tyne Dock are within Port of Tyne Authority land and are not Network Rail infrastructure.</i>
<i>Tyne Dock</i>				

LN670 JARROW BRANCH				
TIMING POINT	DOWN	UP	CODE	NOTES
Pelaw Jn	–	–		<i>To/from Park Lane Jn – LN627</i>
Jarrow Shell Depot		–	S	

LN674 HIGH LEVEL BRIDGE JUNCTION TO GREENSFIELD JUNCTION				
TIMING POINT	DOWN	UP	CODE	NOTES
High Level Bridge Jn	–	–		<i>To/from Newcastle East Jn – LN627</i>
Greensfield Jn	–	–		<i>To/from King Edward Bridge East Jn – LN676</i>

LN676 PARK LANE JUNCTION TO KING EDWARD BRIDGE SOUTH JUNCTION				
TIMING POINT	DOWN	UP	CODE	NOTES
Park Lane Junction	– UML	–		<i>To/from Pelaw Jn – LN627</i>
Greensfield Jn NB All trains to be timed here including those on the Gateshead line	–	–		<i>To/from High Level Bridge Jn – Access to/from the Down Greensfield West Up only – LN674</i>
King Edward Bridge East Junction	–	– DML		<i>To/from King Edward Bridge North Jn – LN620</i>
King Edward Bridge South Jn	–	–		<i>To/from Birtley Jn – LN600 To/from Norwood Jn – LN682</i>
Note Trains in Up Direction is towards Park Lane Junction and the Down Direction is towards King Edward Bridge Junction				

LN678 DARLINGTON NORTH JUNCTION TO EASTGATE				
TIMING POINT	DOWN	UP	CODE	NOTES
<i>Darlington North Junction</i>				<i>To/from Darlington – LN600</i>
North Road	–	–		
Merchant Park	–	–	S	
Heighington	–	–		
Newton Aycliffe	–	–		
Shildon	–	–		
Bishop Auckland				Platform detail must be shown

LN678 DARLINGTON NORTH JUNCTION TO EASTGATE				
TIMING POINT	DOWN	UP	CODE	NOTES
Bishop Auckland West				<i>Bishop Auckland Jn (Exclusive) to Eastgate is controlled by the Weardale Railway who should be contacted for permission to access the line.</i>
Wolsingham Coal Handling Plant				
Eastgate		–		

LN682 KING EDWARD BRIDGE SOUTH JUNCTION TO PETTERIL BRIDGE JUNCTION				
TIMING POINT	DOWN	UP	CODE	NOTES
King Edward Bridge South Junction	–	–		<i>To/from Newcastle – LN600 To/from Greensfield Junction – LN676</i>
Norwood Junction	–	–		<i>To/from Low Fell Junction – LN684</i>
Dunston	–	–	S	
Metrocentre	–	–		
Swalwell Junction	–	–	S	Trains reversing only
Blaydon	–	–		
Wylam	–	–		
Prudhoe	–	–		
Stocksfield	–	–	S	
Riding Mill	–	–	S	
Corbridge	–	–	S	
Hexham	–	–		Platform detail must be shown
Haydon Bridge	–	–		
Bardon Mill	–	–	S	
Haltwhistle	–	–		
Low Row S.B.	–	–		
Brampton (Cumbria)	–	–	S	
Brampton Fell S.B.	–	–		
Corby Gates S.B.	–	–		
Wetheral	–	–	S	
Petteril Bridge Junction	–	–		<i>To/from London Road Jn – NW9901</i>

LN684 LOW FELL JUNCTION TO NORWOOD JUNCTION				
TIMING POINT	DOWN	UP	CODE	NOTES
Low Fell Junction	–	– SL	X	<i>To/from Birtley Junction – LN600</i>
Low Fell Royal Mail Terminal	–	–	S	
Norwood Junction	–	–		<i>To/from Metrocentre – LN682</i>

LN694 BENTON NORTH JUNCTION TO MORPETH NORTH JUNCTION VIA BEDLINGTON

TIMING POINT	DOWN	UP	CODE	NOTES
Benton North Junction	–	–	X	To/from Heaton South Jn – LN600
Newsham L.C. Bedlington Furnaceway Sdgs	–	–		
Bedlington North LC	–	–		To/from West Sleekburn Jn – LN702
Hepscott Junction				
Morpeth North Junction	–	–	X	To/from Alnmouth for Alnwick – LN600

LN696 HEPSCOTT JUNCTION TO MORPETH JUNCTION

TIMING POINT	DOWN	UP	CODE	NOTES
Hepscott Junction	–	–		To/from Bedlington North LC – LN694
Morpeth Junction	–	–		To/from Morpeth – LN600

LN698 BUTTERWELL SOUTH BRANCH

TIMING POINT	DOWN	UP	CODE	NOTES
<i>This part of the opencast site is now disconnected and not available for use</i>				

LN700 BUTTERWELL NORTH BRANCH

TIMING POINT	DOWN	UP	CODE	NOTES
Butterwell Junction	–	–	X	To/from Morpeth – LN600
Butterwell Opencast			S	
Potland Burn			S	

LN702 BEDLINGTON NORTH TO LYNEMOUTH ALCAN

TIMING POINT	DOWN	UP	CODE	NOTES
Bedlington North LC	–	–		To/from Benton North Jn – LN694
West Sleekburn Junction	–	–		To/from Winning – LN706
Marchey's House Junction	–	–		To/from Winning – LN708
Ashington Junction	–	–		
Lynemouth Alcan		–	S	
Lynemouth Power Station		–	S	

LN706 WEST SLEEKBURN JUNCTION TO NORTH BLYTH

TIMING POINT	DOWN	UP	CODE	NOTES
West Sleekburn Junction	–	–		To/from Bedlington North – LN702
Winning Junction	–	–		To/from Marchey's House – LN708
Freeman's LC	–	–		
Battleship Wharf		–	S	
North Blyth		–		

LN708 WINNING JUNCTION TO MARCHEY'S HOUSE JUNCTION

TIMING POINT	DOWN	UP	CODE	NOTES
Winning Junction	–	–		<i>To/from North Blyth – LN706</i>
Marchey's House Junction	–	–		<i>To/from Ashington – LN702</i>

LN724 HOLGATE JUNCTION TO SKELTON JUNCTION

TIMING POINT	DOWN	UP	CODE	NOTES
Refer to LN618				

LN736 CLEETHORPES TO NUNNERY MAIN LINE JUNCTION

TIMING POINT	DOWN	UP	CODE	NOTES
Cleethorpes		–		Platform detail must be shown
New Clee	–	–	S	
Grimsby Docks	–	–	S	
Pasture Street Signal 1000		–	S	<i>Located Cleethorpes end of Down/Up Passenger Loop</i>
Pasture Street Signal 981	–		S	<i>Located on Down/Up Main approaching Grimsby Town</i>
Grimsby Town	–	–		Platform detail must be shown
Grimsby Marsh Junction	–	–	X	<i>To/from Great Coates No.1 S.B. – LN740</i>
Great Coates	–	–	S	
Healing	–	–	S	
Stallingborough	–	–		
Habrough	–	–		
<i>Habrough Junction</i>				<i>To/from Ulceby – LN741</i>
Brocklesby Junction	ML GL	–		<i>To/from Ulceby – LN742</i>
Barnetby	FL DGL SL	–		Platform detail must be shown
Wrawby Junction	–	FL SL DGL		<i>To/from Scunthorpe – LN752 To/from Holton-le-Moor – LN200</i>
Brigg	–	–		
Kirton Lime Sidings	–	–		
Kirton Lindsey	–	–		
Northorpe SB	–	–		
Gainsborough Central	–	–		
Gainsborough Trent Jns	–	–		<i>To/from Bessacarr Jn – LN170 To/from Gainsborough Lea Road LN170</i>
West Burton Power Station	–	–	S	
Clarborough Junction	–	–		<i>To/from Cottam Power Station – LN746</i>
Gringley Road Loop		–	S	
Retford Low Level	–	–		Platform detail must be shown
Thrumpton West Junction	–	–		<i>To/from Retford High Level – LN748</i>
Manton Wood Siding	–		S	
Worksop	–	–		Platform detail must be shown
Worksop SS	–	–	S	
Shireoaks East Junction	–	–		<i>To/from Woodend Jn – LN768</i>
Shireoaks West Junction	–	–	X	<i>To/from Woodend Jn – LN782</i>

LN736 CLEETHORPES TO NUNNERY MAIN LINE JUNCTION				
TIMING POINT	DOWN	UP	CODE	NOTES
Shireoaks	–	–		
Brancliffe East Junction	–	–		<i>To/from Dinnington Jn – LN758</i>
Kiveton Park	–	–		
Kiveton Bridge	–	–	S	
Woodhouse Junction	–	–		<i>To/from Beighton Junction – LN816</i>
Woodhouse Sidings	–	–	S	
Woodhouse	–	–	S	
Darnall	–	–	S	
Woodburn Junction	–	–		<i>To/from Broughton Lane Jn – LN830</i>
Nunnery Main Line Junction	–	–		<i>To/from Sheffield – LN804</i>

LN738 GREAT COATES NO.1 TO UNION DOCK				
TIMING POINT	DOWN	UP	CODE	NOTES
Great Coates No.1 SB	–	–		<i>To/from Grimsby Marsh Jn – LN740</i>
Grimsby Union Dock		–		

LN740 MARSH WEST JUNCTION TO HUMBER ROAD JUNCTION				
TIMING POINT	DOWN	UP	CODE	NOTES
Grimsby Marsh Junction	–	–	X	<i>To/from Habrough – LN736</i>
Grimsby West Marsh TC	–		S	
Great Coates No.1 SB	–	–		<i>To/from Grimsby Union Dock – LN738</i>
Pyewipe Road SB		–		<i>To/from Yards</i>
Immingham Texaco	–		S	
Immingham East Jn.	–	–		<i>To/from Yards</i>
Immingham TMD	–	–	S	
Immingham SS	–	–	S	
Immingham Reception	–	–	S	
Immingham A2 Siding	–		S	
Immingham B4 Siding	–		S	
Immingham Hargreaves	–		S	
Humber Road Junction	–	–		<i>To/from Ulceby – LN742</i>

LN741 HABROUGH JUNCTION TO ULCEBY SOUTH JUNCTION				
TIMING POINT	DOWN	UP	CODE	NOTES
<i>Habrough Junction</i>				<i>To/from Habrough – LN736</i>
<i>Ulceby South Junction</i>				<i>To/from Ulceby – LN742</i>

LN742 KILLINGHOLME TO BROCKLESBY JUNCTION				
TIMING POINT	DOWN	UP	CODE	NOTES
Killingholme	–			
Immingham Headshunt RR	–		S	
Immingham Signal 253	–		S	<i>Trains on Down Killingholme only</i>
Immingham HIT	–		S	

LN742 KILLINGHOLME TO BROCKLESBY JUNCTION				
TIMING POINT	DOWN	UP	CODE	NOTES
Immingham Bulk Terminal	–		S	
Immingham Ore Terminal	–		S	
Immingham West Junction	–	–		
Immingham Storage West	–		S	
Immingham Dock CT	–		S	
Immingham Mineral Quay	–		S	
Immingham Pad 1	–		S	
Humber Road Junction	–	–		<i>To/from Immingham East Jn – LN740</i>
Lindsey Oil Refinery	–	–	S	
Humber Oil Refinery	–	–	S	
<i>Ulceby North Junction</i>				<i>To/from Barton-on-Humber – LN744</i>
Ulceby	–	–		
<i>Ulceby South Junction</i>				<i>To/from Habrough Jn – LN741</i>
Brocklesby Junction	ML GL	–		<i>To/from Barnetby – LN736</i>

LN744 ULCEBY NORTH JUNCTION TO BARTON ON HUMBER				
TIMING POINT	DOWN	UP	CODE	NOTES
<i>Ulceby North Junction</i>				<i>To/from Ulceby – LN742</i>
Thornton Abbey	–	–	S	<i>All trains in the down direction must come to a stand to wait for the Drivers White Lights for Barton Road Level Crossing</i>
Goxhill	–	–	S	
Oxmarsh	–	–	S	<i># Stop required for Token Working</i>
New Holland	–	–	S	
Barrow Haven	–	–	S	
Barton on Humber	–	–		

LN746 COTTAM POWER STATION TO CLARBOROUGH JUNCTION				
TIMING POINT	DOWN	UP	CODE	NOTES
Cottam Power Station	–			
Clarbrough Junction	–	–		<i>To/from Retford – LN736</i>

LN748 RETFORD WESTERN JUNCTION TO THRUMPTON WEST JUNCTION				
TIMING POINT	DOWN	UP	CODE	NOTES
<i>Retford Western Junction</i>	–			<i>To/from Retford (High Level) – LN101</i>
Thrumpton West Junction	–	–		<i>To/from Worksop – LN736</i>

LN750 WOODBURN JUNCTION TO DEEPCAR				
TIMING POINT	DOWN	UP	CODE	NOTES
Woodburn Junction	–	–		To/from Woodhouse – LN736 To/from Broughton Lane Jn – LN830
Deepcar				NR boundary
Stocksbridge Works		–		

LN752 WRAWBY JUNCTION TO MARSHGATE JUNCTION				
TIMING POINT	DOWN	UP	CODE	NOTES
Wrawby Junction	–	FL SL DGL		To/from Brocklesby – LN736
Foreign Ore Branch Junction	–	–	X	To/from Santon F.O.T. –LN754
North Lincoln Junction	DSG	–	X	
Scunthorpe Corus CHP	–		S	
Scunthorpe Anchor Exchange	–		S	
Scunthorpe Container Terminal	–		S	
Scunthorpe Entrance 'C'	–		S	
Scunthorpe Trent TC	– DSG		S	
Scunthorpe Trent Junction	–	–	X	To/from Roxby – LN756
Scunthorpe FD	–	–	S	
Frodingham Jn	–	– ML USG	X	
Scunthorpe	–	–		Platform detail must be shown
Scunthorpe West Jn				
Gunhouse Loop		–	S	
Althorpe	–	–	S	
Crowle	–	–		
Thorne South	–	–	S	
Thorne Junction	– SL	–		To/from Goole – LN912
Hatfield Colliery	– USL	–	SF	
Hatfield & Stainforth	– SL	– SL		To/from Applehurst Jn –LN842
Kirk Sandall	–	–	S	
Kirk Sandall Junction	–	– SL	XF	To/from Low Ellers Curve Jn – LN758
Bentley Junction	– AL	–		To/from Hexthorpe Jn – LN826
Marshgate Junction				To/from Doncaster – LN101

LN754 SCUNTHORPE FOREIGN ORE BRANCH				
TIMING POINT	DOWN	UP	CODE	NOTES
Foreign Ore Branch Junction	–	–		To/from Appleby – LN752
Santon Foreign Ore Terminal		–		

LN756 SCUNTHORPE TRENT JUNCTION TO ROXBY				
TIMING POINT	DOWN	UP	CODE	NOTES
Scunthorpe Trent Junction	–	–	X	To/from North Lincoln Jn – LN752
Normanby Park GF	–	–	S	
Dragonby Sidings	–	–	S	
Flixborough Wharf	–	–	S	
Roxby Gullet	–	–		

LN758 BRANCLIFFE EAST JUNCTION TO KIRK SANDALL JUNCTION				
TIMING POINT	DOWN	UP	CODE	NOTES
Brancliffe East Junction	–	–		To/from Shireoaks – LN736
WP605 Signal	–			
WP606 Signal		–		
Dinnington Junction	–	–		
Maltby RJB Mining			S	
Maltby Colliery SB	–	–		
Firbeck Junction	–	–		
St Catherines Junction	–	–		To/from Decoy South Junction – LN762
Low Ellers Curve Junction	–	–		To/from Potteric Carr Junction – LN764
Kirk Sandall Junction	– SL	–		To/from Hatfield and Stainforth – LN752

LN762 ST CATHERINE'S JUNCTION TO DECOY SOUTH JUNCTION				
TIMING POINT	DOWN	UP	CODE	NOTES
St Catherine's Junction	–	–		To/from Brancliffe East Jn – LN758
Decoy South Junction	–	–		To/from Decoy North Jn – LN150

LN764 ST CATHERINE'S JUNCTION TO POTTERIC CARR JUNCTION (LOW ELLERS CURVE)				
TIMING POINT	DOWN	UP	CODE	NOTES
St Catherine's Junction	–	–		To/from Brancliffe East Jn – LN758
Low Ellers Curve Junction	–	–		
Potteric Carr Junction	–	–		To/from Doncaster Up Decoy – LN101

LN766 BENTLEY JUNCTION TO HEXTHORPE JUNCTION (DONCASTER AVOIDING LINE)				
TIMING POINT	DOWN	UP	CODE	NOTES
Bentley Junction	AL	–		To/from Hatfield & Stainforth – LN752
Hexthorpe Junction	–	AL		To/from Conisbrough – LN826

LN768 MANSFIELD WOODHOUSE TO SHIREOAKS EAST JUNCTION				
TIMING POINT	DOWN	UP	CODE	NOTES
Mansfield Woodhouse	–	–		<i>To/from Kirkby Lane End Jn – LN3273</i>
Shirebrook	–	–	S	
Shirebrook Jn	–	–	F	<i>To/from Warsop Jn – LN722</i>
Shirebrook East Junction				<i>To/from Warsop Jn – LN784</i>
Langwith Whaley Thorns	–	–	S	
Creswell	–	–	S	
Elmton & Cresswell Jn	–	–	F	
Whitwell Derby SB	–	–	F	
Whitwell	–	–	S	
Woodend Junction	–	–		<i>To/from Shireoaks West Jn – LN736</i>
Shireoaks East Junction	–	–		<i>To/from Worksop – LN736</i>

LN772 WARSOP JUNCTION TO SHIREBROOK JUNCTION				
TIMING POINT	DOWN	UP	CODE	NOTES
Warsop Junction	–	–		<i>To/from Welbeck Colliery Jn – LN784</i>
Shirebrook Junction	–	–	X	<i>To/from Mansfield – LN768</i>

LN774 BARROW NORTH HILL JUNCTION TO OXCROFT DISPOSAL POINT				
TIMING POINT	DOWN	UP	CODE	NOTES
Barrow Hill North Jn	–	–		<i>To/from Tipton Jn – LN768</i>
Hall Lane Junction	–	–		
Seymour Junction	–	–		
Oxcroft Junction	–	–		
Oxcroft RJB Mining		–	S	

LN776 HALL LANE JUNCTION TO FOXLOW JUNCTION				
TIMING POINT	DOWN	UP	CODE	NOTES
Hall Lane Junction	–	–		<i>To/from Seymour Jn – LN774</i>
Foxlow Junction	–	–	X	<i>To/from Beighton Jn – LN806</i>

LN778 SEYMOUR JUNCTION TO BOLSOVER				
TIMING POINT	DOWN	UP	CODE	NOTES
Seymour Junction	–	–		<i>To/from Hall Lane Jn – LN774</i>
Bolsover Coalite		–	S	

LN782 WOODEND JUNCTION TO SHIREOAKS WEST JUNCTION				
TIMING POINT	DOWN	UP	CODE	NOTES
Woodend Junction	–	–		<i>To/from Whitwell – LN757</i>
Shireoaks West Junction	–	–	X	<i>To/from Shireoaks – LN736</i>

LN784 HIGH MARNHAM TO SHIREBROOK EAST JUNCTIONS

TIMING POINT	DOWN	UP	CODE	NOTES
High Marnham	–	–		
Boughton Junction	–	–	X	To/from Bevercotes – LN786
Thoresby Colliery Junction	–	–		To/from Thoresby Colliery – LN788
Clipstone East Junction	–	–		To/from Clipstone South Jn – LN790
Clipstone West Junction	–	–		To/from Clipstone South Jn – LN800
Welbeck Colliery Junction	–	–		To/from Welbeck Colliery – LN802
Warsop Junction	–	–		To/from Shirebrook Jn – LN772
Shirebrook East Junction	–	–		To/from Woodend Jn – LN768

LN786 BEVERCOTES COLLIERY BRANCH

TIMING POINT	DOWN	UP	CODE	NOTES
Boughton Junction	–	–		To/from High Marnham – LN784
Bevercotes Colliery		–	S	

LN788 THORESBY COLLIERY BRANCH

TIMING POINT	DOWN	UP	CODE	NOTES
Thoresby Colliery Junction	–	–		To/from High Marnham – LN784
Thoresby Colliery		–	S	

LN790 RUFFORD NO.1 COAL STACKING SITE TO CLIPSTONE EAST JUNCTION

TIMING POINT	DOWN	UP	CODE	NOTES
Clipstone South Junction	–	–		Line OOU beyond 10m68ch
Clipstone East Junction	–	–		To/from High Marnham – LN784

LN800 CLIPSTONE SOUTH JUNCTION TO CLIPSTONE WEST JUNCTION

TIMING POINT	DOWN	UP	CODE	NOTES
Clipstone South Junction	–	–		To/from Clipstone Colliery Jn – LN790
Clipstone West Junction	–	–		To/from Warsop Jn – LN784

LN802 WELBECK COLLIERY BRANCH

TIMING POINT	DOWN	UP	CODE	NOTES
Welbeck Colliery Junction	–	–		To/from High Marnham – LN784
Welbeck Colliery Run Round	–	–		
Welbeck Colliery		–	S	

LN804 TAPTON JUNCTION TO GASCOIGNE WOOD JUNCTION VIA SHEFFIELD

TIMING POINT	DOWN	UP	CODE	NOTES
Tapton Junction	–	ML UBH DBH		To/from Chesterfield – LN3201 To/from Barrow Hill North Jn – LN806
Dronfield	–	–	S	
Dore South Jn	–	–	X	To/from Dore West Jn – LN807
Dore Station Junction	–	–		To/from Dore West Junction – LN808
Heeley Up Loop		–	S	
Sheffield Signal S77	DPL		X	
Sheffield Signal S81	–		S	
Sheffield HS	–		S	
Sheffield	–			Platform detail must be shown
Nunnery Main Line Junction	–	–		To/from Woodburn Jn – LN736
Mill Race Junction	–	–	X	
Attercliffe Sidings	–	–	S	
Brightside Up & Down East Slow	–	–	S	
Brightside Jn	– SL	– GL	X	
Wincobank Jn	–	SL		To / From Ecclesfield West SB LN868
Meadowhall Interchange	–	–	S	
Holmes Junction	– DGL	–		To/from Rotherham Central – LN818
Masborough Junction	–	–	XF	To/from Beighton Jn – LN806
Aldwarke Junction	–	–		To/from Rotherham Central – LN830 To/from Thrybergh Junction – LN828
Swinton	–	–		To/from Mexborough – LN826
Bolton upon Dearne	–	–	S	
Goldthorpe	–	–	S	
Thurnscoe	–	–	S	
Moorthorpe Goods Loop	–	–	S	
Moorthorpe	–	–		To/from South Kirkby Jn – LN824
Moorthorpe Signal L6586		-	S	
Pontefract Baghill	–	–	S	
Ferrybridge North Junction	–	–		To/from Knottingley – LN892
Ferrybridge PowerGen		–	S	
Ferrybridge HS		–	S	
Ferrybridge NP Depot		–	S	
Milford Jn	–	–		To/from Castleford – LN854 To/from Church Fenton – LN854
Milford West Sdgs	–	–	S	
Gascoigne Wood Junction	–	–		To/from Hambleton West Jn – LN898

LN806 TAPTON JUNCTION TO MASBOROUGH JUNCTION VIA 'OLD ROAD'

TIMING POINT	DOWN	UP	CODE	NOTES
Tapton Junction	–	–		To/from Chesterfield – LN3201
Barrow Hill South Junction	– GL	–	X	
Barrow Hill SS	–	–	S	
Barrow Hill North Junction	–	–		To/from Hall Lane Jn – LN774
Foxlow Junction	–	–	X	To/from Hall Lane Jn – LN776
Westthorpe Run Round	–		S	

LN806 TAPTON JUNCTION TO MASBOROUGH JUNCTION VIA 'OLD ROAD'				
TIMING POINT	DOWN	UP	CODE	NOTES
Beighton Junction	–	–		<i>To/from Woodhouse Junction – LN816</i>
Treeton Junction	–	–	F	
Up Canklow Goods Loop	–	–	S	
Masborough SS South Junction	–	–	X S	
Masborough FD			S	
Masborough Junction	–	–	X F	<i>To/from Aldwarke Jn – LN804</i>

LN807 DORE SOUTH JUNCTION TO DORE WEST JUNCTION				
TIMING POINT	DOWN	UP	CODE	NOTES
Dore South Junction	–	–	X	<i>To/from Dronfield – LN804</i>
Dore West Junction	–	–		<i>To/from Topley Tunnel East Jn – LN808</i>

LN808 DORE STATION JUNCTION TO TOTLEY TUNNEL EAST				
TIMING POINT	DOWN	UP	CODE	NOTES
Dore Station Jn	–	–		<i>To/from Sheffield – LN804</i>
Dore & Topley	–	–	S	
Dore West Jn	–	–		<i>To/from Dore South Jn – LN807</i>
Topley Tunnel East	–	–		<i>To/from Grindleford – NW9001</i>

LN809 SHEPCOTE LANE WEST JUNCTION TO TINSLEY YARD EAST END				
TIMING POINT	DOWN	UP	CODE	NOTES
<i>Shepcote Lane West Junction</i>				<i>To/from Tinsley South Jn – LN810</i>
Shepcote Lane East Junction	–	–		For train planning purposes, this location is known as Shepcote Lane Jn. <i>To/from Broughton Lane Jn – LN812</i>
Tinsley Yard		–		

LN810 SHEPCOTE LANE WEST JUNCTION TO TINSLEY SOUTH JUNCTION				
TIMING POINT	DOWN	UP	CODE	NOTES
<i>Shepcote Lane West Junction</i>				<i>To/from Shepcote Lane East Jn – LN809</i>
Tinsley South Junction	–	–		<i>To/from Tinsley East Jn – LN830</i>

LN812 SHEPCOTE LANE EAST JUNCTION TO BROUGHTON LANE JUNCTION				
TIMING POINT	DOWN	UP	CODE	NOTES
Shepcote Lane East Junction	–	–		<i>To/from Tinsley Yard – LN809</i>
Broughton Lane Junction	–	–		<i>To/From Woodburn Junction- LN830</i>

LN814 TINSLEY NORTH JUNCTION TO SHEFFIELD TRAM TRANSFER LINE				
TIMING POINT	DOWN	UP	CODE	NOTES
Tinsley North Junction	–	–		<i>Tram Only To/from LN830</i>
<i>Sheffield Tram W210</i>	–	–		

LN815 PARKGATE JUNCTION TO SHEFFIELD TRAM PARKGATE TRANSFER LINE				
TIMING POINT	DOWN	UP	CODE	NOTES
Parkgate Junction	–	–		<i>Tram Only To/from LN830</i>
Sheffield Tram Parkgate	–	–		

LN816 BEIGHTON JUNCTION TO WOODHOUSE JUNCTION				
TIMING POINT	DOWN	UP	CODE	NOTES
Beighton Junction	–	–		<i>To/from Barrow Hill North Jn – LN806</i>
<i>Beighton Station Junction Signal Box</i>				
Woodhouse Junction	–	–		<i>To/from Woodburn Jn – LN736</i>

LN818 HOLMES JUNCTION TO ROTHERHAM CENTRAL JUNCTION (HOLMES CURVE)				
TIMING POINT	DOWN	UP	CODE	NOTES
Holmes Junction	–	–		<i>To/from Meadowhall – LN804</i>
<i>Rotherham Booth's</i>			S	
<i>Rotherham Central Junction</i>	–	–		<i>To/from Aldwarke Jn – LN830</i>

LN824 MOORTHORPE JUNCTION TO SOUTH KIRKBY JUNCTION				
TIMING POINT	DOWN	UP	CODE	NOTES
Moorthorpe	–	–		<i>To/from Swinton – LN804</i>
South Kirkby Junction	–	–		<i>To/from Hare Park Jn – LN836</i>

LN826 DONCASTER SOUTH YORKSHIRE JUNCTION TO SWINTON				
TIMING POINT	DOWN	UP	CODE	NOTES
<i>South Yorkshire Junction</i>				<i>To/from Doncaster – LN101</i>
<i>St James' Junction</i>	GL	GL	X	<i>To/from Bridge Jn – LN832</i>
<i>Hexthorpe Sdgs</i>	GL	GL	S	
Hexthorpe Junction	–	– GL AL		<i>To/from Bentley Jn – LN766</i>
<i>Cadeby Up Goods Loop</i>		–	S	
<i>Conisbrough</i>	–	–	S	
Mexborough	–	–		<i>To/from Thrybergh Jn – LN828</i>
Swinton	–	–		<i>To/from Aldwarke Jn – LN804</i>

LN828 MEXBOROUGH JUNCTION TO ALDWARKE JUNCTION VIA KILNHURST

TIMING POINT	DOWN	UP	CODE	NOTES
<i>Mexborough Junction</i>	–	–		<i>To/from Hexthorpe Junction – LN826</i>
Kilnhurst Up Goods Loop		–	S	
Thrybergh Junction	–	–		
Aldwarke Junction	–	–		<i>To/from Holmes Jn – LN804</i> <i>To/from Rotherham Central – LN830</i>

LN830 ALDWARKE JUNCTION TO WOODBURN JUNCTION

TIMING POINT	DOWN	UP	CODE	NOTES
Aldwarke Junction	–	–		<i>To/from Swinton – LN804</i> <i>To/from Thrybergh Jn – LN828</i>
Aldwarke New Site	–		S	
Aldwarke Jn Sig S738		–	S	Reversing point on Up Tinsley Line
Aldwarke Jn Sig S1092		–	S	Reversing point on Down Tinsley Line
Parkgate Junction	–	–	X	To/from Sheffield Tram Parkgate, Tram only – LN815
Rotherham Central	–	–		<i>To/from Holmes Jn – LN818</i>
Tinsley East Junction	–	–		
Tinsley North Junction	–	–	X	To/from Sheffield Tram W210, Tram only – LN814
Tinsley South Junction	–	–		<i>To/from Shepcote Lane West Jn – LN810</i>
Broughton Lane Junction	–	–		<i>To/from Shepcote Lane East Jn – LN812</i>
Woodburn Junction	–	–		<i>To/from Nunnery Main Line Jn – LN736</i>

LN832 DONCASTER BRIDGE JUNCTION TO ST. JAMES JUNCTION

TIMING POINT	DOWN	UP	CODE	NOTES
Bridge Junction	GL–	– WSL		<i>To/from Decoy North Jn – LN101</i>
St. James Junction	GL	GL		<i>To/from Nunnery Main Line Jn – LN736</i>

LN836 DONCASTER MARSHGATE JUNCTION TO NEVILLE HILL EAST JUNCTION

TIMING POINT	DOWN	UP	CODE	NOTES
Doncaster Marshgate Junction	–	–	S	To/from Doncaster – LN101
Bentley	–	–	S	
Adwick	–	–		
Carcroft Junction	–	–	X	To/from Skellow Junction – LN846
Adwick Junction	–	–		To/from Skellow Junction – LN842
South Elmsall	–	–	S	
South Kirkby Junction	–	–		To/from To/from Moorthorpe – LN824
Hemsworth Loops	–	–	S	
Fitzwilliam	–	–	S	
Wintersett	–	–	S	Out of Use STNC/G1/2017/LNE/001
Hare Park Junction	–	–		To/from Crofton West Jn – LN848
Sandall and Agbrigg	–	–	S	
Wakefield Westgate South Junction				To/from Wakefield Kirkgate – LN850
Wakefield Westgate	–	–		Platform detail must be shown
Prison Sidings		–	S	
Wrenthorpe Sidings		–	S	
Outwood	–	–	S	
Copley Hill West Jn	CHC	–	X	Only when crossing to/from E or F lines or UWC/DWC. Next/previous timing point Whitehall Junction
Holbeck Junction	–	–		To/from Mill Lane Jn – LN852
Whitehall Jn	C E UWC	–		Not a timing point on A or B lines. To/from Engine Shed Jn – LN840 To/from Armley Jn – LN922
Leeds West Junction	A B C E F BS CS ES CN CNS EN	DH D E F UM		The line codes shown between Leeds West Jn and Leeds in both directions are the lines the train is on at Leeds West Jn. The line codes shown between Leeds West Jn and Whitehall Jn are the lines the trains are on at the east side of Whitehall Jn. Line codes other than those shown are available for ARS/SSI alternative routes but should not be used for normal timetabling purposes. Further details are available from the Operational Planning Project Manager, Network Rail. F Line to be used in Down direction for Platform 16/17 only. Line codes ending in 'S' are for trains to Platforms 11 and 12 east end only via Platforms 11 and 12 West. Line codes ending in 'N' are ARS "Non-Favourite" routes. To/from Engine Shed Jn – LN872
Leeds	–	B D E F BS DS DN DNS EN FS		Platform detail must be shown. Line codes ending in 'S' are for trains from Platforms 11 and 12 east end only via Platforms 11 and 12 West. Line codes ending in 'N' are ARS "Non-Favourite" routes.
Marsh Lane Junction	– GL	–	X	

LN836 DONCASTER MARSHGATE JUNCTION TO NEVILLE HILL EAST JUNCTION

TIMING POINT	DOWN	UP	CODE	NOTES
Marsh Lane Tilcon	–		S	
Neville Hill West Jn	–	– FL GL		Trains in up direction from Neville Hill T&RSMD must be shown FL or GL <i>To/from Hunslet East - LN900</i>
Neville Hill T&RSMD	–	–	S	
Neville Hill Up Sidings	–	GL	S	
Neville Hill East Junction	–	GL –	X	<i>To/from Cross Gates – LN898</i>

LN838 LEEDS ARMLEY JUNCTION TO YORK SKELTON JUNCTION VIA HARROGATE

TIMING POINT	DOWN	UP	CODE	NOTES
Armley Jn	–	UH		<i>To/from Whitehall Jn – LN922</i>
Burley Park	–	–	S	
Headingley	–	–	S	
Horsforth	–	–		
Weeton	–	–	S	
Rigton LC	–	–		
Pannal	–	–	S	
Hornbeam Park	–	–	S	
Harrogate	–	–		Platform detail must be shown
Starbeck	–	–		
Knaresborough	–	–		Platform detail must be shown <i>Token Exchange Point</i>
Cattal	–	–		<i>Token Exchange Point</i>
Hammerton	–	–		<i>Token Exchange Point</i>
Poppleton	–	–		<i>Token Exchange Point</i>
Skelton Jn	– DL	–		<i>To/from York – LN600</i> <i>To/from York Yard – LN618</i>

LN840 ENGINE SHED JUNCTION TO WHITEHALL EAST JUNCTION

TIMING POINT	DOWN	UP	CODE	NOTES
Engine Shed Junction	DWC UWC	–		<i>To/from Stourton Jn – LN872</i>
<i>Whitehall East Junction</i>				<i>To/from Copley Hill East Junction – LN836</i> <i>To/from Holbeck Junction or Armley Junction – LN836</i>

LN842 THORPE MARSH JUNCTION TO ADWICK JUNCTION

TIMING POINT	DOWN	UP	CODE	NOTES
Thorpe Marsh Junction	–	–		<i>To/from Hatfield & Stainforth – LN888</i>
Applehurst Junction	–	–		<i>To/from Joan Croft Jn – LN844</i>
Skellow Junction	–	–		<i>To/from Carcroft Jn – LN846</i>
Adwick Junction	–	–		<i>To/from South Kirkby Jn – LN836</i>

LN844 APPLEHURST JUNCTION TO JOAN CROFT JUNCTION (APPLEHURST LOOP)

TIMING POINT	DOWN	UP	CODE	NOTES
Applehurst Jn	–	–		<i>To/from Hatfield & Stainforth – LN842</i>
Joan Croft Jn	–	–	X	<i>To/from Temple Hirst Jn – LN600</i>

LN846 CARCROFT JUNCTION TO SKELLOW JUNCTION

TIMING POINT	DOWN	UP	CODE	NOTES
Carcroft Jn	–	–	X	<i>To/from Adwick – LN836</i>
Skellow Jn	–	–		<i>To/from Applehurst Jn – LN842</i>

LN848 HARE PARK JUNCTION TO CROFTON WEST JUNCTION

TIMING POINT	DOWN	UP	CODE	NOTES
Hare Park Junction	–	–		<i>To/from South Kirby Junction – LN836</i>
Crofton West Junction	–	–		<i>To/from Turners Lane Jn – LN822</i>

LN850 WAKEFIELD WESTGATE SOUTH JUNCTION TO WAKEFIELD KIRKGATE WEST JUNCTION

TIMING POINT	DOWN	UP	CODE	NOTES
<i>Wakefield Westgate South Junction</i>				<i>To/from Wakefield Westgate – LN836</i>
<i>Wakefield Kirkgate West Junction</i>				<i>To/from Wakefield Kirkgate – LN854</i>

LN852 HOLBECK JUNCTION TO BRADFORD INTERCHANGE

TIMING POINT	DOWN	UP	CODE	NOTES
Holbeck Junction	—	–		<i>To/from Whitehall Jn – LN836</i>
Bramley	–	–	S	
New Pudsey	–	–	S	
Laisterdyke	–	–	S	
Laisterdyke Sig M1558		–	S	Reversal point on Down line
Hammerton Street Loop	–	–	S	
Mill Lane Junction	–	–		<i>To/from Halifax – LN858</i>
Bradford Interchange	–	–		Platform detail must be shown

LN854 HALL ROYD JUNCTION TO COLTON JUNCTION

TIMING POINT	DOWN	UP	CODE	NOTES
Hall Royd Junction	–	–		<i>To/from Littleborough – NW7001</i> <i>To/from Copy Pit – NW7009</i>
Hebden Bridge	–	–		
Mytholmroyd	–	–	S	
Signal HB7	–			Down trains only
Signal MR8		–		Up trains only
Sowerby Bridge	–	–	S	

LN854 HALL ROYD JUNCTION TO COLTON JUNCTION				
TIMING POINT	DOWN	UP	CODE	NOTES
Milner Royd Junction	–	–		<i>To/from Dryclough Jn – LN858</i>
Greetland Junction	–	–		<i>To/from Dryclough Jn – LN859</i>
Brighouse	–	–	S	
Bradley Wood Junction	–	–		<i>To/from Bradley Jn – LN861</i>
Heaton Lodge Junction		–		Up trains only <i>To Huddersfield – LN860</i>
Heaton Lodge East Junction	–			Down Trains only <i>From Huddersfield – LN860</i>
Mirfield	–	FL SL	S	
Mirfield East Junction	–	FL SL		
Thornhill LNW Junction	–	–		Trains from Dewsbury and trains towards Healey Mills only
Dewsbury East Junction	–	–	X	<i>To/from Dewsbury Railway Street – LN864</i>
Healey Mills Yard	–	–	S	
Healey Mills B Junction		–	S	
Horbury Up Goods Loop		–	S	
Horbury Junction	FL SL	–		<i>To/from Barnsley – LN868</i>
<i>Wakefield Kirkgate West Junction</i>				<i>To/from Wakefield Westgate South Jn – LN850</i>
Wakefield Kirkgate	– GL	FL SL		Platform details must be shown. <i>To/from Calder Bridge Jn – LN882</i>
Turner's Lane Junction	–	– GL	X	<i>To/from Calder Bridge Jn – LN870</i>
Normanton	–	–	S	
Altofts Junction	–	–		<i>To/from Methley Jn – LN872</i>
Whitwood Junction	–	–	X	<i>To/from Methley Jn – LN874</i>
<i>Castleford West Junction</i>				<i>To/from Pontefract Monkhill – LN875</i>
Castleford	–	–		
Milford Junction	–	–		<i>To/from Ferrybridge North Jn/Gascoigne Wood Jn – LN804</i>
Milford Loops	–	–	S	
Sherburn Junction	–	–	X	<i>To/from Gascoigne Wood – LN878</i>
Sherburn-in-Elmet	–	–	S	
Church Fenton	NNL LSL	–		Platform details must be shown
<i>Church Fenton North Junction</i>				<i>To/from Micklefield – LN902</i>
Ulleskelf	NNL LSL	NNL LSL	S	
Colton South Junction	LSL	NNL	X	
Colton Junction	NNL LSL	NNL LSL		<i>To/from Hambleton North Jn/York – LN600</i>

LN858 MILNER ROYD JUNCTION TO BRADFORD MILL LANE JUNCTION				
TIMING POINT	DOWN	UP	CODE	NOTES
Milner Royd Junction	–	–		<i>To/from Sowerby Bridge – LN854</i>
Dryclough Junction	–	–		<i>To/from Greetland Jn – LN859</i>
Halifax Reversing Sdg	–	–	S	
Halifax	–	–		
Low Moor	–	–	S	
Mill Lane Junction	–	–		<i>To/from Bradford Interchange – LN852</i>

LN859 GREETLAND JUNCTION TO DRYCLOUGH JUNCTION				
TIMING POINT	DOWN	UP	CODE	NOTES
Greetland Jn	–	–		To/from Brighouse – LN854
Dryclough Junction	–	–		To/from Halifax – LN858

LN860 DIGGLE JN TO COPLEY HILL EAST JN				
TIMING POINT	DOWN	UP	CODE	NOTES
Diggle Junction	–	–		To/from Greenfield – NW7021
Marsden	–	–		Platform detail must be shown
Slaithwaite	–	–	S	
Huddersfield	–	–		Platform detail must be shown
Deighton	–	–	S	
Bradley Junction	–	–		To/from Bradley Wood Jn – LN861
Heaton Lodge Junction		–		Up trains only To Bradley Wood Junction – LN854
Heaton Lodge East Junction	–			Down trains only From Bradley Wood Junction – LN854
Mirfield	–	FL SL	S	
Mirfield East Junction	–	FL SL		From Horbury Junction – LN854
Thornhill LNW Junction		–		Trains from Dewsbury and trains towards Healey Mills only To Horbury Junction – LN854
Ravensthorpe	–	–	S	
Dewsbury	–	–		Line/Platform detail must be shown
Batley	–	–	S	
Morley	–	–		
Cottingley	–	–	S	
Copley Hill East Jn	–			To/from Whitehall Road Jn – LN836

LN861 BRADLEY JUNCTION TO BRADLEY WOOD JUNCTION				
TIMING POINT	DOWN	UP	CODE	NOTES
Bradley Junction	–	–	X	To/from Huddersfield – LN860
Bradley Wood Junction	–	–		To/from Brighouse – LN854

LN862 BARNSELY STATION JUNCTION TO HUDDERSFIELD				
TIMING POINT	DOWN	UP	CODE	NOTES
<i>Barnsley Station Junction</i>				<i>To/from Barnsley – LN868</i>
Dodworth	–	–	S	
Silkstone Common	–	–	S	
Penistone	–	–		
Denby Dale	–	–	S	
Clayton West Junction	–	–		
Shepley	–	–	S	
Stocksmoor	–	–		
Brockholes	–	–	S	
Berry Brow	–	–	S	
Lockwood	–	–	S	
Springwood Junction	–	–	X	Only trains not terminating in Platform 2
Huddersfield	–	–		Platform detail must be shown <i>To/from Heaton Lodge East Jn – LN860</i>

LN864 DEWSBURY RAILWAY STREET BRANCH				
TIMING POINT	DOWN	UP	CODE	NOTES
Dewsbury Railway Street	–			
Dewsbury East Junction	–	–	X	<i>To/from Horbury Jn – LN854</i>

LN868 WINCOBANK JUNCTION TO HORBURY JUNCTION VIA BARNSELY				
TIMING POINT	DOWN	UP	CODE	NOTES
Wincobank Junction	–	–		<i>To/from Nunnery Mainline Jn – LN804</i>
Meadowhall	–	– SL	S	Platform detail must be shown
Ecclesfield West SB	–	–		
Chapelton	–	–	S	
Elsecar	–	–	S	
Wombwell	–	–	S	
Barnsley	–	–		Platform detail must be shown
<i>Barnsley Station Junction</i>				<i>To/from Penistone – LN862</i>
Darton	–	–	S	
Woolley Coal Sdg SB	–	–		
Horbury Junction	FL SL	–		<i>To/from Wakefield Kirkgate – LN854</i>

LN870 TURNER'S LANE JUNCTION TO CALDER BRIDGE JUNCTION				
TIMING POINT	DOWN	UP	CODE	NOTES
Turner's Lane Junction	–	–	X	<i>To/from Altofts Jn – LN854</i>
Calder Bridge Junction	–	–		<i>To/from Crofton West Jn – LN882</i>

LN872 ALTOFTS JUNCTION TO LEEDS WEST JUNCTION				
TIMING POINT	DOWN	UP	CODE	NOTES
Altofts Junction	–	–		<i>To/from Wakefield Kirkgate – LN854</i>
Wakefield Europort		–	S	

LN872 ALTOFTS JUNCTION TO LEEDS WEST JUNCTION				
TIMING POINT	DOWN	UP	CODE	NOTES
Methley Junction	–	–		<i>To/from Whitwood Jn – LN874</i>
Woodlesford	–	–	S	
Stourton Junction	– AD	–		
Leeds Signal L928		AD	S	Crew change location
Leeds Signal L929	AD	–	S	Crew change location
Leeds Freightliner Terminal	–	–	S	
Hunslet South Junction		–	S	
Leeds Balm Road		–	S	
Leeds Stourton RMC		–	S	
Hunslet SS	–		S	
Hunslet Station Junction	–	– AD	X	
Holbeck Depot		–	S	
Engine Shed Junction	DM DWC UWC	–		<i>To/from Whitehall Jn – LN840</i>
Leeds West Junction	E	UM DM		<i>To/from Leeds – LN836</i>

LN874 METHLEY JUNCTION TO WHITWOOD JUNCTION				
TIMING POINT	DOWN	UP	CODE	NOTES
Methley Junction	–	–		<i>To/from Woodlesford – LN872</i>
Whitwood Junction	–	–	X	<i>To/from Castleford – LN854</i>

LN875 CASTLEFORD WEST JUNCTION TO PONTEFRACT WEST JUNCTION				
TIMING POINT	DOWN	UP	CODE	NOTES
<i>Castleford West Junction</i>				<i>To/from Castleford – LN854</i>
Glasshoughton	–	–	S	
<i>Pontefract West Junction</i>				<i>To/from Pontefract Monkhill – LN882</i>

LN878 SHERBURN JUNCTION TO GASCOIGNE WOOD				
TIMING POINT	DOWN	UP	CODE	NOTES
Sherburn Junction	–	–	X	<i>To/from Church Fenton – LN854</i>
Gascoigne Wood Junction	–	–		<i>To/from Hambleton West Jn – LN898</i>

LN880 YORK TO SCARBOROUGH				
TIMING POINT	DOWN	UP	CODE	NOTES
York	–	– NNL LSL		Platform detail must be shown <i>To/from Colton Jn – LN600</i>
Scarborough Bridge Junction	–	–		
Bootham	–		S	Steam locomotive watering point in down direction
Strensall	–	–		
Barton Hill	–			
Kirkham Abbey	–	–		
Malton	–	–		
Weaverthorpe	–	–		
<i>Seamer West Junction</i>				<i>To/from Filey – LN914</i>
Seamer	–	–		
Scarborough		–		Platform detail must be shown

LN882 WAKEFIELD KIRKGATE WEST JUNCTION TO GOOLE POTTER'S GRANGE JUNCTION				
TIMING POINT	DOWN	UP	CODE	NOTES
<i>Wakefield Kirkgate West Junction</i>				
Wakefield Kirkgate	–	–		Platform detail must be shown <i>To/from Horbury Jn – LN854</i> <i>To/from Wakefield Westgate – LN850</i>
Wakefield Withams Cobra	–	–	S	
Calder Bridge Junction	–	–		<i>To/from Turners Lane Jn – LN870</i>
Oakenshaw Up Goods Loop			S	
Oakenshaw Junction	–	–	X	<i>To/from Oakenshaw South Jn – LN884</i>
Crofton West Junction	–	–		<i>To/from Hare Park Jn – LN848</i>
Crofton East Junction	–	–		<i>To/from Oakenshaw South Jn – LN886</i>
Crofton Depot	–		S	
Crofton East Spur	–	–	S	
Streethouse	–	–	S	
Featherstone	–	–	S	
Pontefract Tanshelf	–	–	S	
<i>Pontefract West Junction</i>				<i>To/from Castleford – LN875</i>
Pontefract Monkhill	–	–		Platform detail must be shown
Pontefract East Jn	–	–	X	<i>To/from Ferrybridge South Jn – LN892</i>
Knottingley West Junction	–	–		<i>To/from Ferrybridge North Jn – LN888</i> <i>To/from Knottingley South Jn – LN888</i>
Knottingley	–	–	P	
Knottingley WRD	UGL		S	
Knottingley TMD	–		S	
Knottingley Signal FE6418		–	S	Crew change location
Knottingley Up Goods Loop		UGL	S	Crew change location
Knottingley East Junction	–	– UGL		
England Lane LC		–	S	
Sudforth Lane SB	–	–		
Kellingley Colliery	–		S	
Sudforth Lane Down Sidings	–	–	S	
Sudforth Lane Up RS		–	S	

LN882 WAKEFIELD KIRKGATE WEST JUNCTION TO GOOLE POTTER'S GRANGE JUNCTION

TIMING POINT	DOWN	UP	CODE	NOTES
Whitley Bridge	–	–		
Whitley Bridge Jn.	–	–	X	
Eggborough Power Station		–	S	
Hensall	–	–		
Drax Branch Junction	–	–		<i>To/from Drax Power Station – LN896</i>
Snaith	–	–		
Rawcliffe	–	–		
Potters Grange Junction	–	–	X	<i>To/from Thorne Junction – LN912</i>

LN884 OAKENSHAW SOUTH JUNCTION TO OAKENSHAW JUNCTION

TIMING POINT	DOWN	UP	CODE	NOTES
Oakenshaw South Jn	–	–		<i>To/from Monk Bretton – LN886</i>
Oakenshaw Jn	–	–	X	<i>To/from Calder Bridge Jn – LN882</i>

LN886 MONK BRETTON LOOP TO CROFTON EAST JUNCTION

TIMING POINT	DOWN	UP	CODE	NOTES
Monk Bretton	–	–		
Royston Junction	–	–		
Oakenshaw South Jn	–	–		<i>To/from Oakenshaw Jn – LN884</i>
Crofton East Jn	–	–		<i>To/from Pontefract – LN882</i>

LN888 HATFIELD AND STAINFORTH (STAINFORTH JUNCTION) TO FERRYBRIDGE NORTH JUNCTION

TIMING POINT	DOWN	UP	CODE	NOTES
Hatfield & Stainforth	–	SL		To/from Thorne Jn – LN752
Thorpe Marsh Junction	–	–		To/from Applehurst Jn – LN842
Haywood Junction	–	–		To/from Shaftholme Junction – LN889
Knottingley South Jn	–	–		To/from Knottingley East Jn (England Lane) – LN894
Knottingley West Junction	–	–		To/from Pontefract Monkhill – LN882
Ferrybridge North Junction	–	–		To/from Milford Junction – LN804

LN889 SHAFTHOLME JUNCTION TO HAYWOOD JUNCTION

TIMING POINT	DOWN	UP	CODE	NOTES
Shaftholme Jn	–	–		To/from Doncaster – LN101
Haywood Junction	–	–		To/from Ferrybridge North Junction – LN888

LN892 PONTEFRACT EAST JUNCTION TO FERRYBRIDGE SOUTH JUNCTION

TIMING POINT	DOWN	UP	CODE	NOTES
Pontefract East Junction	–	–	X	To/from Pontefract Monkhill – LN882
Ferrybridge South Junction				To/from Milford Jn – LN804

LN894 KNOTTINGLEY SOUTH JUNCTION TO KNOTTINGLEY EAST JUNCTION

TIMING POINT	DOWN	UP	CODE	NOTES
Knottingley South Junction	–	–		To/from Shaftholme Jn – LN888
Knottingley East Junction	–	–	FSX	To/from Sudforth Lane – LN882

LN896 DRAX POWER STATION BRANCH

TIMING POINT	DOWN	UP	CODE	NOTES
Drax Branch Jn	–	–	FX	To/from Sudforth Lane – LN882
Drax Power Station Signal D17	–			
Drax Power Station	–	–		

LN898 NEVILLE HILL EAST JUNCTION TO HULL

TIMING POINT	DOWN	UP	CODE	NOTES
Neville Hill East Junction	–	GL –	X	To/from Leeds – LN836
Cross Gates	–	–		
Garforth	–	–	S	
East Garforth	–	–	S	
Micklefield	–	–		
Micklefield Junction				To/from Church Fenton – LN902

LN898 NEVILLE HILL EAST JUNCTION TO HULL				
TIMING POINT	DOWN	UP	CODE	NOTES
South Milford	–	–	S	
Gascoigne Wood Junction	–	–		To/from Sherburn Jn – LN878 To/from Milford Jn – LN804
Gascoigne Wood Down Loop	–	–	S	
Gascoigne Wood Down Sidings	–	–	S	
Gascoigne Wood Up Sidings	–	–	S	
Hambleton West Junction	–	–		To/from Hambleton South Jn – LN904
Hambleton East Junction	–	–		To/from Hambleton North Jn – LN906
Selby West Junction	– UL	–	X	To Selby Platform 3 To/from Selby Canal Jn – LN908
Selby South Junction				To/from Selby Canal Jn – LN910
Selby	–	–		Platform detail must be shown
Barlby Loop	–	–	S	
Selby Potter Group		–	S	
Wressle	–	–	S	
Howden	–	–	S	
Eastrington	–	–	S	
Gilberdyke	–	–		To/from Goole – LN912
Broomfleet	–	–	S	
Crabley Creek Signal Box				Signal Box for AB Section
Brough	–	–		
Brough East Signal Box				Signal Box for AB Section
Melton Lane Signal Box				Signal Box for AB Section
Ferriby	–	– SL	S	Slow Line between Ferriby and Welton Lane LC
Hessle	–	–	S	
Hull Yard	–		S	
Hessle East Junction	–	–	X F	
Dairycoats (Tilcon)	–	–	S	
Hessle Road Junction	–	–		To/from Hull Saltend – LN916
Anlaby Road Junction	–	–	X F	To/from West Parade North Jn – LN920
Botanic Gardens TMD	–	–	S	
West Parade Junction				To/from West Parade North Jn – LN914
Hull		–		Platform detail must be shown

LN900 NEVILLE HILL WEST JUNCTION TO HUNSLET EAST				
TIMING POINT	DOWN	UP	CODE	NOTES
Neville Hill West Jn	–	– FL GL		To/from Neville Hill – LN836
Hunslet East		–		

LN902 MICKLEFIELD JUNCTION TO CHURCH FENTON NORTH JUNCTION				
TIMING POINT	DOWN	UP	CODE	NOTES
Micklefield Junction				To/from Leeds – LN898
Church Fenton	NNL LSL	–		Platform detail must be shown
Church Fenton North Junction				To/from York – LN854

LN904 HAMBLETON SOUTH JUNCTION TO HAMBLETON WEST JUNCTION				
TIMING POINT	DOWN	UP	CODE	NOTES
Hambleton South Jn	–	–	X	<i>To/from Shaftholme Jn – LN600</i>
Hambleton West Jn	–	–		<i>To/from Neville Hill East Jn – LN898</i>

LN906 HAMBLETON EAST JUNCTION TO HAMBLETON NORTH JUNCTION				
TIMING POINT	DOWN	UP	CODE	NOTES
Hambleton East Jn	–	–		<i>To/from Selby – LN898</i>
Hambleton North Jn	–	–		<i>To/from York – LN600</i>

LN908 SELBY WEST JUNCTION TO SELBY CANAL JUNCTION				
TIMING POINT	DOWN	UP	CODE	NOTES
Selby West Junction	–	–	X	<i>To/from Hambleton East – LN898</i>
Selby Canal Junction	–	–	XF	<i>To/from Temple Hirst Jn – LN910</i>

LN910 TEMPLE HIRST JUNCTION TO SELBY SOUTH JUNCTION				
TIMING POINT	DOWN	UP	CODE	NOTES
Temple Hirst Junction	–	–		<i>To/from Shaftholme Jn – LN600</i>
Selby Canal Junction	–	–	XF	<i>To/from Temple Hirst Jn – LN910</i>
<i>Selby South Junction</i>				<i>To/from Selby – LN898</i>

LN912 THORNE JUNCTION TO GILBERDYKE JUNCTION				
TIMING POINT	DOWN	UP	CODE	NOTES
Thorne Junction	–	– SL		<i>To/from Hatfield & Stainforth – LN752</i>
Thorne North	–	–	S	
Goole Glassworks	–	–	S	
Potters Grange Junction	–	–	X	<i>To/from Rawcliffe – LN882</i>
Goole Docks	–	–	S	
Goole Up & Down Goods Loop	–	–	S	
Goole	–	–		Platform detail must be shown
Saltmarshe	–	–	S	
<i>Gilberdyke Junction</i>	–	–		<i>To/from Brough – LN898</i>

LN914 HULL TO SEAMER WEST JUNCTION				
TIMING POINT	DOWN	UP	CODE	NOTES
Hull	–			Platform detail must be shown
<i>West Parade Junction</i>				<i>To/from Anlaby Road Jn – LN898</i>
West Parade North Junction	–	–	X	<i>To/from Anlaby Road Jn – LN920</i>
Walton St. Junction	–	–	X	<i>To/from Springbank North Jn – LN918</i>
Cottingham	–	–	S	
Beverley	–	–		
Arram	–	–	S	
Hutton Cranswick	–	–	S	
Driffield	–	–		
Nafferton	–	–	S	
Bridlington	–	–		Platform detail must be shown
Bempton	–	–	S	
Hunmanby	–	–		
Filey	–	–		
<i>Seamer West Junction</i>				<i>To/from Scarborough – LN880</i>

LN916 HESSLE ROAD JUNCTION TO SALTEND				
TIMING POINT	DOWN	UP	CODE	NOTES
Hessle Road Junction		–		<i>To/from Brough – LN898</i>
Springbank South Junction	–	–		
Springbank North Junction	–	–		<i>To/from Walton St. Jn – LN918</i>
Bridges Junction	–	–		
Hull Dock Security Gates	–	–		
Hedon Road Sdgs	–	–		
Hull Coal Terminal	–	–		
Hull Saltend BP		–		

LN918 SPRINGBANK NORTH JUNCTION TO WALTON STREET JUNCTION				
TIMING POINT	DOWN	UP	CODE	NOTES
Springbank North Jn	–	–		<i>To/from Hessle Road Jn – LN916</i>
Walton Street Jn	–	–	X	<i>To/from Hull – LN914</i>

LN920 ANLABY ROAD JUNCTION TO WEST PARADE NORTH JUNCTION				
TIMING POINT	DOWN	UP	CODE	NOTES
Anlaby Road Jn	–	–	X	<i>To/from Hessle Road Jn – LN898</i>
West Parade North Jn	–	–	X	<i>To/from Beverley – LN914</i>

LN922 WHITEHALL WEST JUNCTION TO HELLIFIELD SOUTH JUNCTION				
TIMING POINT	DOWN	UP	CODE	NOTES
Whitehall Junction	DS US	C D UWC DWC		Not a timing point on A or B/Down or Up Shipley Main lines <i>To/from Leeds – LN836</i>
Armley Junction	–	US UH DS DH		
Kirkstall Down Loop	–	–	S	
Kirkstall Up Loop	–	–	S	
Kirkstall Forge	–	–	S	
Apperley Junction	–	–		<i>To/from Ilkley – LN924</i>
Apperley Bridge	–	–	S	
Dockfield Junction	–	–		<i>To/from Baildon – LN926</i>
<i>Shipley East Jn</i>				<i>To/from Bradford Forster Square – LN928</i>
Shipley	–	–		Platform detail must be shown
<i>Shipley West Jn</i>				<i>To/from Shipley South Jn – LN932</i>
Saltaire	–	–	S	
Bingley	–	–	S	
Crossflatts	–	–	S	
Keighley	–	–		Platform detail must be shown
Keighley Station Jn	–	–	S	<i>To/from Keighley & Worth Valley Railway</i>
Steeton and Silsden	–	–	S	
Cononley	–	–	S	
Skipton Sig. L4031	–			Regulation/reversal point on Down Shipley Main
Skipton Sig. L4549	–			Reversal point on Up Shipley Main
Skipton Down Stabling Siding	–		S	
Skipton	–	–		Platform detail must be shown
<i>Skipton Middle Jn</i>				<i>To/from Rylstone – LN930</i>
Broughton Road CS	–	–	S	
Down Shipley Slow	–	–	S	
Skipton Signal L4046	–	–	S	Regulation point on Up Shipley Main
Gargrave	–	–	S	
<i>Hellifield South Junction</i>	–	–		<i>To/from Settle Jn – NW9901</i>

LN924 APPERLEY JUNCTION TO ILKLEY				
TIMING POINT	DOWN	UP	CODE	NOTES
Apperley Junction	–	–		<i>To/from Leeds – LN922</i>
<i>Esholt Junction</i>				<i>To/from Dockfield Junction – LN926</i>
Guisley	–	–		
Menston	–	–	S	
Burley in Wharfedale	–	–		
Ben Rhydding	–	–	S	
Ilkley	–	–		Platform detail must be shown

LN926 DOCKFIELD JUNCTION TO ESHOLT JUNCTION				
TIMING POINT	DOWN	UP	CODE	NOTES
Dockfield Junction	–	–		<i>To/from Shipley – LN922</i>
Baildon	–	–	S	
<i>Esholt Junction</i>	–	–		<i>To/from Ilkley – LN924</i>

LN928 SHIPLEY EAST JUNCTION TO BRADFORD FORSTER SQUARE				
TIMING POINT	DOWN	UP	CODE	NOTES
<i>Shipley East Junction</i>				<i>To/from Leeds – LN922</i>
Shipley	–	–		Platform detail must be shown
<i>Shipley South Junction</i>				<i>To/from Shipley West Jn – LN932</i>
Shipley Crossley Evans		–	S	
Frizinghall	–	–	S	
Bradford Forster Square		–		Platform detail must be shown

LN930 SKIPTON MIDDLE JUNCTION TO RYLSTONE				
TIMING POINT	DOWN	UP	CODE	NOTES
<i>Skipton Middle Junction</i>				<i>To/from Skipton – LN922</i>
Rylstone		–		

LN932 SHIPLEY SOUTH JUNCTION TO SHIPLEY WEST JUNCTION				
TIMING POINT	DOWN	UP	CODE	NOTES
<i>Shipley South Junction</i>				<i>To/from Bradford Forster Square – LN928</i>
Shipley	–	–		Platform detail must be shown
<i>Shipley West Junction</i>				<i>To/from Skipton – LN922</i>

2.2 Route Opening Hours

Subject to constraints imposed by Rules of the Route, all routes are open continuously, except as shown below. The hours shown reflect the contractual opening hours. The actual opening hours may vary from those shown. If there is doubt about a signalbox's opening hours check with the appropriate Network Rail Operations Manager.

When the routes shown are required for services diverted under the Rules of the Route, opening hours will be increased as necessary on a temporary basis.

Signal boxes equipped to be switched-out during a route's opening hours are shown within the routes concerned.

PLT denotes passage of last train.

LN170 WERRINGTON JUNCTION TO FLYOVER EAST JUNCTION (VIA LINCOLN)			
ROUTE SECTION	SX	SO	SUN
Werrington Junction to Gainsborough Trent West Junction (Inclusive)	Continuous	Continuous	Continuous
Gainsborough Trent West Junction (Exclusive) to Bessacarr Junction	From 0930 Mon	Until 2130	Closed

LN185 ALLINGTON WEST JUNCTION TO SKEGNESS			
ROUTE SECTION	SX	SO	SUN
Allington West Jn to Boston	0610 – 2310	0610 – 2310	0835 – 2135
Boston to Skegness	0620 – 2156	0620 – 2156	0925 – 2125

LN190 ALLINGTON EAST JUNCTION TO ALLINGTON NORTH JUNCTION (ALLINGTON CHORD)			
ROUTE SECTION	SX	SO	SUN
Allington East Junction to Allington North Junction	0515 – 2309	0515 – 2309	0905 – 2320

LN195 GRANTHAM NOTTINGHAM BRANCH JUNCTION TO ALLINGTON WEST JN (INCLUSIVE)			
ROUTE SECTION	SX	SO	SUN
Grantham Nottingham Jn to Allington West Junction	0515 – 2305	0515 – 2305	0905 – 2320

LN200 WRABBY JUNCTION TO PELHAM STREET JUNCTION

ROUTE SECTION	SX	SO	SUN
Wrawby Junction to Pelham Street Junction	Continuous	Until 2320	From 1045

LN206 NEWARK FLAT CROSSING (INCLUSIVE) TO WEST HOLMES JUNCTION

ROUTE SECTION	SX	SO	SUN
Newark Castle to Swinderby	Continuous	Until 2300	From 1525
Swinderby to West Holmes/Pyewipe Jn.	Continuous	Until 2320	From 1045

LN626 NORTHALLERTON HIGH JUNCTION TO NORTHALLERTON EAST JUNCTION

ROUTE SECTION	SX	SO	SUN
Northallerton High Jn to Northallerton East Jn.	Continuous	0000 – 2359	0830 – 2400

LN627 LONGLANDS JUNCTION TO NEWCASTLE EAST JUNCTION VIA THE COAST

ROUTE SECTION	SX	SO	SUN
Longlands Jn to Stockton Cut	Continuous	Continuous	Continuous
Stockton Cut to Billingham	Continuous	0000 – 2359	08:01 – 2400
Billingham Junction to Belasis Lane	Continuous	0000 – 20:00	22:00 – 23:59
Greatham to Sunderland (excl)	Continuous	0000 – 0056*	0800 – 2400
Sunderland (excl) to South Hylton	Continuous	Continuous	Continuous
Sunderland to High Level Bridge Junction	Continuous	Continuous	Continuous

*Extended opening hours listed below are agreed for the purpose of operating specific Arriva Rail North services. These are subject to Network Rail receiving funding on an ongoing basis as agreed between Arriva Rail North and Network Rail.

Greatham to Sunderland (excl) closes at 0056 vice 2350 SO

LN631 DARLINGTON SOUTH JUNCTION TO EAGLESCLIFFE SOUTH JUNCTION

ROUTE SECTION	SX	SO	SUN
Darlington South to Allens West	0510* – 0030*	0515 – 0030*	0712* – 2356*
Low Gates to Eaglescliffe	Continuous	0000 – 2359	0830 – 2400

*Extended opening hours listed below are agreed for the purpose of operating specific Arriva Rail North services. These are subject to Network Rail receiving funding on an ongoing basis as agreed between Arriva Rail North and Network Rail.

Darlington South to Allens West opens at 0510 vice 0515 and closes at 0030 vice 2345 SX

Darlington South to Allens West closes at 0030 vice 2345 SO

LN631 DARLINGTON SOUTH JUNCTION TO EAGLESCLIFFE SOUTH JUNCTION

ROUTE SECTION	SX	SO	SUN
<i>Darlington South to Allens West opens at 0712 vice 0730 and closes at 2356 vice 2345 SUN</i>			

LN632 STOCKTON CUT JUNCTION TO SALTBURN

ROUTE SECTION	SX	SO	SUN
Newport East to Saltburn	Continuous	0000 – 2359	0830 – 2400 Middlesbrough open from 0730

LN634 GUISBOROUGH JUNCTION TO WHITBY

ROUTE SECTION	SX	SO	SUN
Guisborough Junction to Whitby Shunts at signal M695 controlled by Middlesbrough Signal Box. Check EAS and Compendium of Signal Box Opening Times	0636 –2130*	0636 –2130*	0800 – 2000 (All Year Round)*

*Extended opening hours listed below are agreed for the purpose of operating specific Arriva Rail North services. These are subject to Network Rail receiving funding on an ongoing basis as agreed between Arriva Rail North and Network Rail.

Guisborough Junction to Whitby closes 2130 vice 2124 SX
Guisborough Junction to Whitby closes 2130 vice 2124 SO
Guisborough Junction to Whitby opens All Year Round vice Summer Months Only

LN642 SALTBURN WEST JUNCTION TO BOULBY POTASH MINE

ROUTE SECTION	SX	SO	SUN
Saltburn West Jn. To Boulby	Continuous	0000 – 2359	0830 – 2359

LN646 NORTON-ON-TEES SOUTH TO FERRYHILL SOUTH JUNCTION

ROUTE SECTION	SX	SO	SUN
Norton South to Ferryhill	Continuous	0000 – 1401	Closed
Norton East Junction to Norton West Junction	As required	As required	Closed

LN664 BOLDON EAST JUNCTION TO BOLDON NORTH JUNCTION

ROUTE SECTION	SX	SO	SUN
Boldon East Jn to Boldon North Jn	Continuous	0000 – 2300	0800 – 2400

LN666 BOLDON WEST JUNCTION TO TYNE DOCK			
ROUTE SECTION	SX	SO	SUN
Boldon West to Green Lane Junction	Continuous	0000 – 2300	0800 – 2400
Green Lane Junction to Tyne Biomass/Coal Loading Sidings	Not NR Infrastructure	Not NR Infrastructure	Not NR Infrastructure

LN678 DARLINGTON NORTH JUNCTION TO EASTGATE			
ROUTE SECTION	SX	SO	SUN
Darlington North Junction to Bishop Auckland and Eastgate	0645–2230	0645–2230	07:30-20:00

LN682 KING EDWARD BRIDGE SOUTH JUNCTION TO PETTERIL BRIDGE JUNCTION			
ROUTE SECTION	SX	SO	SUN
Blaydon to Petteril Bridge	Open continuously from 0540 (Mon)	0001 – 2350*	0840 – 2200

**Extended opening hours listed below are agreed for the purpose of operating specific Arriva Rail North services. These are subject to Network Rail receiving funding on an ongoing basis as agreed between Arriva Rail North and Network Rail.*

Blaydon to Petteril Bridge closes 2350 vice 2340 SO

LN694 BENTON NORTH JUNCTION TO MORPETH NORTH JUNCTION VIA BEDLINGTON			
ROUTE SECTION	SX	SO	SUN
Benton Junction to Morpeth (via Bedlington)	0530 - 2200*	0530 - 2200*	Closed
Bedlington to Blyth	0530 - 2200*	0530 - 2200*	Closed
Marcheys House to Lynemouth	0530 - 2200*	0530 - 2200*	Closed

**Extended opening hours listed below are agreed for the purpose of operating specific GB Railfreight Ltd services. These are subject to Network Rail receiving funding on an ongoing basis as agreed between GB Railfreight Ltd and Network Rail.*

Benton Junction to Morpeth (via Bedlington) Closes at 22:00 vice 21:00 SX
 Bedlington to Blyth Closes at 22:00 vice 21:00 SX
 Marcheys House to Lynemouth Closes at 22:00 vice 21:00 SX
 Benton Junction to Morpeth (via Bedlington) Opens at 05:30 vice 09:00 AND Closes at 22:00 vice 15:30 SO
 Bedlington to Blyth Opens at 05:30 vice 09:00 AND Closes at 22:00 vice 15:30 SO
 Marcheys House to Lynemouth Opens at 05:30 vice 09:00 AND Closes at 22:00 vice 15:30 SO

LN736 CLEETHORPES TO NUNNERY MAIN LINE JUNCTION VIA RETFORD			
ROUTE SECTION	SX	SO	SUN
Habrough to Grimsby (excl)	0450 – 0002	0450 – 0002	0930 – 0045
Wrawby Junction (excl) to Gainsborough Central	1400 – 2359 (Mon – Fri) 0000 – 0600 (Tue – Fri)	00.00 – 2100	Closed
Gainsborough Trent Junction	0540 – 2359	0000 – 2152	09:25* - 23:15*
West Burton to Shireoaks (incl)	Continuous	Continuous	Continuous
Shireoaks (excl) to Woodburn Junction (excl)	Continuous	0500 – 2359	08:30* – 23:50*
Woodburn Junction to Nunnery ML Junction	Continuous	0000 – 2400	08:30* – 24:00

*Extended opening hours listed below are agreed for the purpose of operating specific Arriva Rail North services. These are subject to Network Rail receiving funding on an ongoing basis as agreed between Arriva Rail North and Network Rail.

Gainsborough Trent Junction opens at 09:25 vice 13:40 on Sundays.
Shireoaks to Woodburn Junction and Woodburn Junction to Nunnery Main Line opens at 08:30 vice 13:50 on Sundays.
Gainsborough Trent Junction closes at 23:15 vice 23:00 on Sundays.
Shireoaks to Woodburn Junction closes at 23:50 vice 23:00 Sundays.

LN740 GRIMSBY MARSH WEST JUNCTION TO HUMBER ROAD JUNCTION			
ROUTE SECTION	SX	SO	SUN
Immingham/Grimsby Light Railway	Open as Required		

LN742 KILLINGHOLME TO BROCKLESBY JUNCTION			
ROUTE SECTION	SX	SO	SUN
Humber Road Junction to Immingham West	Continuous	0000 – 2400	0801 – 2400

LN744 ULCEBY NORTH JUNCTION TO BARTON ON HUMBER			
ROUTE SECTION	SX	SO	SUN
Ulceby to Barton on Humber	0620 – 2232	0620 – 2232	1000 – 1940

LN758 BRANCLIFFE EAST JUNCTION TO KIRK SANDALL JUNCTION			
ROUTE SECTION	SX	SO	SUN
Brancliffe East Junction to St Catherine's Junction	Continuous	0000 – 1530	1400 – 2400

LN768 MANSFIELD WOODHOUSE TO SHIREOAKS EAST JUNCTION			
ROUTE SECTION	SX	SO	SUN
Mansfield Woodhouse to Shireoaks Junctions	Continuous	0000 – 2300	1400 – 2400

LN774 BARROW HILL NORTH JUNCTION TO OXCROFT DISPOSAL POINT			
ROUTE SECTION	SX	SO	SUN
Barrow Hill to Oxcroft/Bolsover	0530 – 2209	0530 – 1445	1500 – 2100

LN784 HIGH MARNHAM TO SHIREBROOK EAST JUNCTION			
ROUTE SECTION	SX	SO	SUN
High Marnham and Branches to Shirebrook Junctions	Continuous	0000 – 2200	1500 – 2400

LN804 TAPTON JUNCTION TO GASCOIGNE WOOD JUNCTION VIA SHEFFIELD			
ROUTE SECTION	SX	SO	SUN
Swinton Junction to South Kirkby	Continuous	0000 – 2400	0845* – 2400
Moorthorpe (excl) to Gascoigne Wood	Continuous	0000 – 2300	0750 – 2400

*Extended opening hours listed below are agreed for the purpose of operating specific Arriva Rail North services. These are subject to Network Rail receiving funding on an ongoing basis as agreed between Arriva Rail North and Network Rail.

Swinton Junction to South Kirkby opens at 0845 vice 0900 SUN

LN809 SHEPCOTE LANE WEST JUNCTION TO TINSLEY YARD EAST END			
ROUTE SECTION	SX	SO	SUN
Tinsley South Junction to Tinsley Yard	Continuous	0000 – 2359	1350 – 2400

LN816 BEIGHTON JUNCTION TO WOODHOUSE JUNCTION			
ROUTE SECTION	SX	SO	SUN
Beighton Junction (excl) to Woodhouse Junction (excl)	Continuous	0001 – 0015*	1330 – 2359

*Extended opening hours listed below are agreed for the purpose of operating specific Arriva Rail North services. These are subject to Network Rail receiving funding on an ongoing basis as agreed between Arriva Rail North and Network Rail.

Beighton Junction (excl) to Woodhouse Junction (excl) closes at 0015 vice 2200 SO

LN830 ALDWARKE JUNCTION TO WOODBURN JUNCTION

ROUTE SECTION	SX	SO	SUN
Rotherham Central (excl) to Woodburn Junction	Continuous	0000 – 2359	0830 – 2400

*Extended opening hours listed below are agreed for the purpose of operating specific Supertram services. These are subject to Network Rail receiving funding on an ongoing basis as agreed between Stagecoach Supertram and Network Rail.

Rotherham Central(excl) to Woodburn Junction Opening hours opens 0830 Sunday vice 1350 Sunday

LN838 LEEDS ARMLEY JUNCTION TO YORK SKELTON JUNCTION VIA HARROGATE

ROUTE SECTION	SX	SO	SUN
Armley Junction to Harrogate	0540 –0020* 0540 –0020*	0540 –0020* 0540 –0020*	0905* – 0015 0905* – 2355
Harrogate (excl) to Skelton Junction	0650 –2248* 0635 –2318*	0650 –2248* 0635 –2318*	1140 –2155* 1115 –2225*

*Extended opening hours listed below are agreed for the purpose of operating specific Arriva Rail North services. These are subject to Network Rail receiving funding on an ongoing basis as agreed between Arriva Rail North and Network Rail.

Armley Junction to Harrogate closes 0020 vice 0010 SX (Applies in both directions)
 Armley Junction to Harrogate closes 0020 vice 0010 SO (Applies in both directions)
 Armley Junction to Harrogate opens 0905 vice 0930 SUN (Applies in both directions)
 Harrogate (excl) to Skelton Junction closes 2248 vice 2226 SX (Applies in Up Direction only)
 Harrogate (excl) to Skelton Junction closes 2318 vice 2235 SX (Applies in Down Direction Only)
 Harrogate (excl) to Skelton Junction closes 2248 vice 2226 SO (Applies in Up Direction only)
 Harrogate (excl) to Skelton Junction closes 2318 vice 2235 SO (Applies in Down Direction Only)
 Harrogate (excl) to Skelton Junction closes 2155 vice 2150 SUN (Applies in Up Direction only)
 Harrogate (excl) to Skelton Junction closes 2225 vice 2210 SUN (Applies in Down Direction Only)

LN852 HOLBECK JUNCTION TO BRADFORD INTERCHANGE

ROUTE SECTION	SX	SO	SUN
Holbeck Junction (Exc) to Bradford Interchange	0500 – 0040	0520 – 0100	0740 –0020*

*Extended opening hours listed below are agreed for the purpose of operating specific Arriva Rail North services. These are subject to Network Rail receiving funding on an ongoing basis as agreed between Arriva Rail North and Network Rail.

Holbeck Junction (Excl) to Bradford Interchange closes 0020 vice 0015 SUN

LN854 HALL ROYD JUNCTION TO COLTON JUNCTION			
ROUTE SECTION	SX	SO	SUN
Hebden Bridge to Milner Royd Junction	Continuous	0000 – 0050 Sun*	0820 – 2359
Milner Royd Junction to Heaton Lodge Junction	Continuous	Continuous	0840 – 2359
Healey Mills to Horbury Junction	Continuous	0001 – 2359	0845 – 2359
Horbury Junction to Castleford	Continuous	0000 – 2400	0835* – 2400
Castleford to Milford Junction	Continuous	0000 – 2300 0000 – 2400	0800 – 2400 0840 – 2400
Milford Junction to Church Fenton (excl)	Continuous	0000 – 2300	0750 – 2400

*Extended opening hours listed below are agreed for the purpose of operating specific Arriva Rail North services. These are subject to Network Rail receiving funding on an ongoing basis as agreed between Arriva Rail North and Network Rail.

Hebden Bridge to Milner Royd Junction Opens 0000 and closes 0050 Sun vice Continuous SO
Horbury Junction to Castleford Opens 0835 vice 0845 Sun

LN858 MILNER ROYD JUNCTION TO BRADFORD MILL LANE JUNCTION			
ROUTE SECTION	SX	SO	SUN
Dryclough Junction to Greetland Junction	0520 – 0035	0535 – 2355	0845 – 2315
Milner Royd Junction to Mill Lane Junction	0530 – 0035 0500 – 0040	0555 – 0035 0520 – 0100	0810 – 0015 0740 – 0015

*Extended opening hours listed below are agreed for the purpose of operating specific Arriva Rail North services. These are subject to Network Rail receiving funding on an ongoing basis as agreed between Arriva Rail North and Network Rail.

Milner Royd Junction to Mill Lane Junction closes 0035 vice 0010 SX (Applies in the Down direction only)
Milner Royd Junction to Mill Lane Junction closes 0035 vice 0025 SO (Applies in the Down direction only)

LN862 BARNSELY STATION JUNCTION TO HUDDERSFIELD			
ROUTE SECTION	SX	SO	SUN
Barnsley Station Junction to Huddersfield	0600 – 2359 0555 – 2355	0600 – 2359 0555 – 2355	0905* – 2055* 0905* – 2055*

*Extended opening hours listed below are agreed for the purpose of operating specific Arriva Rail North services. These are subject to Network Rail receiving funding on an ongoing basis as agreed between Arriva Rail North and Network Rail.

Barnsley Station Junction to Huddersfield opens 0905 vice 0945 and closes 2055 vice 2015 SUN (Applies in the Down Direction only)
Barnsley Station Junction to Huddersfield opens 0905 vice 0910 and closes 2055 vice 2034 SUN (Applies in the Up Direction only)

LN868 WINCOBANK JUNCTION TO HORBURY JUNCTION VIA BARNSELY

ROUTE SECTION	SX	SO	SUN
Wincobank Junction (excl) to Barnsley	0445 –0012* FSX 0445 –0012* FO	0445 – 2350	0825 – 2330
Barnsley Station Junction to Horbury Junction	0600 –2359	0600 – 2359	0855* – 2325

*Extended opening hours listed below are agreed for the purpose of operating specific Arriva Rail North services. These are subject to Network Rail receiving funding on an ongoing basis as agreed between Arriva Rail North and Network Rail.

Wincobank Junction (Excl) to Barnsley closes 0012 vice 0005 FSX
Wincobank Junction (Excl) to Barnsley closes 0012 vice 2350 FO
Barnsley Station Junction to Horbury Junction opens 0855 vice 0915 SUN

LN872 ALTOFTS JUNCTION TO LEEDS WEST JUNCTION

ROUTE SECTION	SX	SO	SUN
Altofts Junction – Leeds (excl)	Continuous	0000 – 2400	0820* – 2400

*Extended opening hours listed below are agreed for the purpose of operating specific Arriva Rail North services. These are subject to Network Rail receiving funding on an ongoing basis as agreed between Arriva Rail North and Network Rail.

Altofts Junction to Leeds (Excl) opens 0820 vice 0830 SUN

LN875 CASTLEFORD WEST JUNCTION TO PONTEFRACT WEST JUNCTION

ROUTE SECTION	SX	SO	SUN
Castleford (excl) to Pontefract Monkhill (excl)	Continuous	0000 – 2400	0900* – 2400

*Extended opening hours listed below are agreed for the purpose of operating specific Arriva Rail North services. These are subject to Network Rail receiving funding on an ongoing basis as agreed between Arriva Rail North and Network Rail.

Castleford (Excl) to Pontefract Monkhill (Excl) opens 0900 vice 0940 SUN

LN880 YORK TO SCARBOROUGH

ROUTE SECTION	SX	SO	SUN
York to Scarborough	0600 –2335*	0600 –2335*	0845 –2335*

* Extended opening hours listed below are agreed for the purpose of operating specific TransPennine Express services. These are subject to Network Rail receiving funding on an ongoing basis as agreed between TransPennine Express and Network Rail.

York to Scarborough Opens at 0600 SX and SO and closes 2335 SX, SO and SU vice 2330 SX, SO and SU

LN882 WAKEFIELD KIRKGATE WEST JUNCTION TO GOOLE POTTER'S GRANGE JUNCTION

ROUTE SECTION	SX	SO	SUN
Wakefield Kirkgate to Pontefract East Junction (excl)	Continuous	0000 –0005*	0845 – 2400
Pontefract East Junction (incl) to Drax Branch Junction (incl)	Continuous	Continous	Continuous
Drax Branch Junction (incl) to Drax Power Station	Continuous	Continous	Continuous
Drax Branch Junction (excl) to Goole Potter's Grange Junction	Continuous	0000 – 2400	0845 – 2400

*Extended opening hours listed below are agreed for the purpose of operating specific Arriva Rail North services. These are subject to Network Rail receiving funding on an ongoing basis as agreed between Arriva Rail North and Network Rail.

Wakefield Kirkgate to Pontefract East Junction (Excl) closes 0005 vice 2400 SO

LN886 MONK BRETTON LOOP TO CROFTON EAST JUNCTION

ROUTE SECTION	SX	SO	SUN
Monk Bretton to Crofton East Jn	Continuous	0000 – 2400	0845 – 2400

LN898 NEVILLE HILL EAST JUNCTION TO HULL

ROUTE SECTION	SX	SO	SUN
Micklefield/Milford/Sherburn in Elmet to Hambleton East	Continuous	0000 –2320	0735** – 2400
Hambleton East to Gilberdyke (excl)	0525**– 2325**	0525** –2325**	0745** –2335**
Gilberdyke to Hull (excl)	0510 –2400**	0510– 0014	0835 – 2359
Selby to Temple Hirst	0550 – 2234	0602 – 2245	0900 – 2250*

* Signal Box opening hours are 1030 to 2215 (SUN) Any trains planned outside these hours require special arrangements to be made with the L.O.M.

**Extended opening hours listed below are agreed for the purpose of operating specific Arriva Rail North and TransPennine Express services. These are subject to Network Rail receiving funding on an ongoing basis, between TransPennine Express, Arriva Rail North and Network Rail.

Micklefield/Milford/Sherburn in Elmet to Hambleton East opens 0735 vice 0800 SUN and Closes 2320 SO vice 2300 SO

Hambleton East to Gilberdyke (Excl) opens 0525 vice 0552 and closes 2325 vice 2238 SX

Hambleton East to Gilberdyke (Excl) opens 0525 vice 0602 and closes 2325 vice 2245 SO

Hambleton East to Gilberdyke (Excl) opens 0745 vice 0850 and closes 2335 vice 2300 SUN

Gilberdyke to Hull (Excl) closes 2400 vice 2352 SX

LN912 THORNE JUNCTION TO GILBERDYKE JUNCTION

ROUTE SECTION	SX	SO	SUN
Thorne Junction to Gilberdyke	0522 –2335*	0522 –2335*	0835*– 0005*

*Extended opening hours listed below are agreed for the purpose of operating specific Arriva Rail North services. These are subject to Network Rail receiving funding on an ongoing basis as agreed between Arriva Rail North and Network Rail.

Thorne Junction to Gilberdyke closes 2335 vice 2310 SX
Thorne Junction to Gilberdyke closes 2335 vice 2310 SO
Thorne Junction to Gilberdyke opens 0835 vice 0845 and closes 0005 vice 2340 SUN

LN914 HULL TO SEAMER WEST JUNCTION

ROUTE SECTION	SX	SO	SUN
Hull to Bridlington	0540*– 2400*	0545 –2400*	0835* –2400*
Bridlington (excl) to Seamer	0615* –2148*	0630 –2148*	0920*– 2205*

*Extended opening hours listed below are agreed for the purpose of operating specific Arriva Rail North services. These are subject to Network Rail receiving funding on an ongoing basis as agreed between Arriva Rail North and Network Rail.

Hull to Bridlington opens 0540 vice 0545 and closes 2400 vice 2345 SX
Hull to Bridlington closes 2400 vice 2345 SO
Hull to Bridlington opens 0835 vice 0900 and closes 2400 vice 2100 SUN
Bridlington (Excl) to Seamer opens 0615 vice 0625 and closes 2148 vice 2118 SX
Bridlington (Excl) to Seamer closes 2148 vice 2118 SO
Bridlington (Excl) to Seamer opens 0920 vice 0950 and closes 2205 vice 1950 SUN

3 Electrification

3.1 Electrification Limits

Limits of the 25 kV AC and 750V DC electrification systems are contained in Table A of the Sectional Appendix to the Working Timetables, issued by, Network Rail. Refer to Table A for the given location to identify the type of electrification that applies.

3.2 Electrification Supply Restrictions

Under normal conditions, the electrification power supplies will not place any restrictions on the use of approved electric traction. However, the Route Clearance sections of the Sectional Appendix to the Working Timetables, issued by, Network Rail do tabulate restrictions on the movement of electric trains. Refer to Table A and select Route Clearance.

Under maintenance conditions, certain sections of the electrified network may be blocked to electric traction. These restrictions are contained within the Network Rail Rules of the Route for the appropriate year. Additional restrictions may also arise in connection with engineering possessions requested through the Rules of the Route amendment procedure.

4 Rolling Stock Restrictions

4.1 Locomotive Route Availability

See the applicable Route Clearance table for the given location in Sectional Appendix to the Working Timetables, issued by Network Rail. Refer to Table A, and select Route Clearance.

4.2 Passenger Stock Restrictions

See the applicable Route Clearance table for the given location in Sectional Appendix to the Working Timetables, issued by Network Rail. Refer to Table A, and select Route Clearance.

4.3 Freight Wagon Restrictions

See the applicable Route Clearance table for the given location in Sectional Appendix to the Working Timetables, issued by Network Rail. The Route Availability for a given location is in the 'Signalling and Remarks' column of Table A. Route Clearance Table D5 Route clearance of freight vehicles gives further guidance on freight wagon restrictions.

Trains conveying vehicles that have a heavy axle weight or other exceptional characteristics, or vehicles conveying containers or swap bodies require an RT3973 form.

Note: The Rule Book GERT8000 Section TW4 defines a container as an intermodal transport unit constructed to a standard (usually specified by the ISO) suitable for conveyance by road, rail or sea.

Note: The Sectional Appendix does not cover the CTRL HS1. The CTRL has its own Working Manual.

4.4 Freight Train Load Limits

Trailing load limits for all traction types are contained in the Freight Loads Book published by Network Rail.

Note: It is important to understand the weight limitations that apply to trains especially over sections of heavily graded routes. Coupling strength information is also contained in the Freight Loads Book. Coupling strength is important in determining the trailing loads that trains can convey.

4.5 Freight Train Length Limits

Refer to the Freight Train Loads Book published by Network Rail for the length limits of freight trains.

Note: The Sectional Appendix quotes loop lengths in metres and feet. All lengths are exclusive of an allowance of one locomotive.

4.6 Engineers' Trains Restrictions

Some On Track Machines (OTMs) do not reliably activate track circuits. These OTMs must use one of the following special reporting numbers 6Z09, 7Z09 or 8Z09*. Because these OTMs do not reliably activate track circuits it is not possible to apply the headways and junction margins as outlined in Timetable Planning Rules consistently and it is therefore not possible for Operational Planning to provide timings for these movements.

* Source GE/RT 8000-OTM

5 Running Times, Margins and Allowances

Except where otherwise stated, the information in this section of the Timetable Planning Rules reflects the general rules used in developing the 1994/5 timetable (Several exceptions to the general rules were agreed for 1994/5 and exceptions may continue to be possible with the specific agreement of Network Rail in every case.)

5.1 Sectional Running Times

The definition for Sectional Running Times (SRTs) is listed in Section 6.4 of the National TPRs.

5.1.1 Source of Current SRTs

The definitive catalogue of SRTs is Bplan.

5.1.2 Method of Calculation

SRTs are revised by Train Operators and Network Rail as part of the Revision of Timetable Planning Rules process outlined in Network Code Part D 2.2. Normally they will not change from one timetable to the next. Network Rail will, however, re-calculate SRTs for particular train/route combinations in the following circumstances:

- i) Where a Train Operator anticipates using a train/route combination for which no suitable SRTs exist;
- ii) Where Network Rail anticipates a change to route data, e.g. line speed changes;
- iii) Where there is evidence that the SRTs in current use do not adequately represent real train performance;
- iv) Where it is cost-effective to re-calculate all SRTs on a route at the same time as a re-calculation for a particular train type.

Network Rail will reflect the methodology and assumptions described in Section 6 of the National TPRs when calculating TPR proposals, unless and to the extent documented otherwise in respect of any given proposal. Timetable participants are encouraged to submit change proposals for review and consultation in line with the national methodology, or in line with such alternative methodology and assumptions as favoured by the proposer. NR will not seek to reject any proposal on the exclusive basis of the methodology employed, provided that the methodology and assumptions are clearly stated and demonstrably adhered to in respect of the proposal received.

SRT change proposals may be calculated in a number of ways including, but not limited to:

- a) Through actual timing of trains
- b) Use of On Train Monitoring Recorder (OTMR) systems
- c) Use of computer system actual values
- d) Use of computer simulation tools
- e) By any other agreed methodology

It is permissible to include percentage uplift in SRTs instead of applying engineering recovery allowances to be agreed by all affected parties.

In the event that the application of different methodologies produces conflicting proposals, a joint observation exercise should be undertaken to ascertain what happens in reality.

5.1.3 New and Revised Sectional Running Times

New and revised SRTs revised by Train Operators and Network Rail on an individual basis. These should be supplied by applying the methodology described in Section 6 of the National TPRs unless another methodology is deemed appropriate, provided that the methodology and assumptions are clearly stated and demonstrably adhered to in respect of the proposal received.

5.1.4 Timing of Trains Consisting of Passenger Vehicles on Goods Lines

The sectional running timings quoted for trains consisting of passenger vehicles on Goods Lines reflect the speeds shown in the relevant Table 'A' of the appropriate Sectional Appendix. They do not constitute an authority to time trains conveying passengers on a Goods Lines. Nor do they reflect the permitted speeds at which a train conveying passengers can proceed. Network Rail will offer the sectional running times for trains conveying passengers on a Goods Line on a train-by-train basis. For those times, please apply to the Capacity Planning Department. Operations Publications publish the authority to allow the planned operation of trains conveying passengers on Goods Lines. Before Operations Publications can grant authority, they require confirmation that the track is fit for purpose and that there is a safe method of operation. Therefore, the Capacity Planning Department must apply to the relevant Track Engineer and Operations Manager for confirmation of these requirements in writing. The Capacity Planning Department must pass these responses to Operations Publications. The Capacity Planning Department is responsible for advising Operations Publications of the requirement to operate a passenger train on a Goods Line at least 8 weeks before the day of operation.

5.2 Headways

The definition for Headways is listed in Section 6.5 of the National TPRs.

5.2.1 Headway Values

All times are in minutes. All routes are shown.

Where track circuit block (TCB) signalling applies, the standard headways for each route are shown, together with any exceptions.

AB indicates locations where absolute block signalling applies: here the headway is to be calculated from the transit time of the first of each pair of trains running between the consecutive block posts being considered. To this transit time shall be added 2 minutes to allow for the signaller's actions. Exceptions are shown as AB and appear together with the actual headway value to be used, which includes the allowance for signallers' actions. Where there is an intermediate block signal, the absolute block section concerned shall be between this signal and the next block post in advance.

Single lines and other forms of signalling are shown, together with any values applicable, where they occur.

"OTNS" or "OT" indicates One Train Working with No Train Staff; "OTS" or "OT(S)" indicates One train Working with Train Staff. "NST" indicates No Signaller token. In these cases only one train is allowed in the section at one time; a second train cannot be allowed to enter the section until the first train has left the section.

"ETB" indicates Electric Token Block and "TB" indicates Tokenless Block for single lines.

"RB" indicates Radio Signalling where "long section tokens" can be issued between certain block posts during times of low traffic volume.

Where headways are shown as being “following a non stop” or “following a stopping” these descriptions refer to the service that the path is following. **The headway value does not refer to running lines.** The “following a stopping” headway should be applied to a service following a preceding service which stops at either a station or any other location for operational reasons. The “following a non-stopping” headway should be applied to a service following a preceding service which does not stop at that location. Immediately the preceding service stops at any location for any reason, the headway should be amended to the “following stopping” value. If in doubt, apply the use of the “following non-stop” headway.

Light engine movements to be treated as passenger trains when applying margins/allowances where there is a passenger/freight differential.

LN101 LONDON KING’S CROSS TO SHAFTHOLME JUNCTION			
TIMING POINT	DOWN	UP	NOTES
Standard Headway	4	4	
Exceptions:			
King’s Cross to Hitchin-Alexandra Palace	3	3	
Alexandra Palace to Woolmer Green Junction	3	3* - Fast 3- Slow	*May be reduced to 2½ where a stopping service at Knebworth has crossed to FL behind a non-stop express service timed at 100mph or above
Woolmer Green Junction to Hitchin	3	3	
Hitchin to Peterborough	3 – Fast 4 – Slow	3 – Fast 4 – Slow	
Helpston to Stoke Junction	4 – Fast 5 – Slow	4 – Fast 5 – Slow	

LN105 MOORGATE TO FINSBURY PARK JUNCTION			
TIMING POINT	DOWN	UP	NOTES
Standard Headway	4	4	

LN120 WOOD GREEN NORTH JUNCTION TO LANGLEY JUNCTION (VIA HERTFORD)			
TIMING POINT	DOWN	UP	NOTES
Alexandra Palace to Gordon Hill	3	3	
Gordon Hill to Hertford	5	5	
Hertford to Langley	3½	3½	Following a train not stopping at Watton – At – Stone
Hertford to Langley	5	5	Following a train stopping at Watton – At –Stone

LN125 HITCHIN CAMBRIDGE JUNCTION TO ROYSTON (INCLUSIVE)

TIMING POINT	DOWN	UP	NOTES
Standard Headway	4	4	

LN170 WERRINGTON JUNCTION TO FLYOVER EAST JUNCTION (VIA LINCOLN)

TIMING POINT	DOWN	UP	NOTES
Werrington Jn to Spalding	5	6	
Spalding to Quadring	4	4	
Quadring to Sleaford Sth Jn	9	7 ½	
Sleaford Sth Jn to Sleaford North Jn	3	3	
Sleaford North Jn to Metheringham	6	5	
Metheringham to Pelham Street Junction	6	7	
Pelham Street Jn to Pyewipe Jn	3	3	
Pyewipe Jn to Saxilby	5 ½	5 ½	
Saxilby to Gainsborough Lea Road	6 ½	6 ½	
Gainsborough Lea Road to Flyover East Junction	4	4 *	* Absolute block for Beckingham to Gainsborough Trent Junction

LN185 ALLINGTON WEST JUNCTION TO SKEGNESS

TIMING POINT	DOWN	UP	NOTES
Allington West Junction to Ancaster	AB	AB	
Ancaster to Rauceby	AB	AB	
Rauceby to Sleaford	AB	AB	
Sleaford to Heckington	Single line		TB planned as AB
Heckington to Hubberts Bridge	AB	AB	
Hubberts Bridge to Sibsey	Single line		TB planned as AB
Sibsey to Bellwater Junction Signal Box	AB	AB	
Bellwater Junction Signal Box to Thorpe Culvert	AB	AB	
Thorpe Culvert to Wainfleet	AB	AB	
Wainfleet to Skegness	AB	AB	

LN190 ALLINGTON EAST JUNCTION TO ALLINGTON NORTH JUNCTION (ALLINGTON CHORD)

TIMING POINT	DOWN	UP	NOTES
Allington East Junction to Allington North Junction	AB	AB	

LN195 GRANTHAM NOTTINGHAM BRANCH JUNCTION TO ALLINGTON WEST JN (INCLUSIVE)

TIMING POINT	DOWN	UP	NOTES
Nottingham Branch Junction to Allington West Junction	AB	AB	

LN200 WRABBY JUNCTION TO PELHAM STREET JUNCTION

TIMING POINT	DOWN	UP	NOTES
Wrawby Junction to Holton le Moor	AB	AB	
Holton le Moor to Wickenby SB	AB	AB	
Wickenby SB to Langworth SB	AB	AB	
Langworth SB to Pelham Street Junction	AB	AB	

LN206 NEWARK FLAT CROSSING (INCLUSIVE) TO WEST HOLMES JUNCTION

TIMING POINT	DOWN	UP	NOTES
Standard Headway	6 Pass.	6 Pass.	<u>Down</u> 6 Freight following Pass. 8 when Freight following Freight <u>Up</u> 6 Freight following Pass. 8 when Freight following Freight
Exceptions:			
Approaching West Holmes Jn	5 if following a train stopping at Hykeham		
Approaching Newark Flat Crossing East Jn		5 if following a train stopping at Collingham	

LN600 SHAFTHOLME JUNCTION TO RESTON GSP			
TIMING POINT	DOWN	UP	NOTES
Standard Headway	4	4	
Exceptions:			
York to Colton Junction	4	4	<p><u>Down</u> A stopping service can follow 3 minutes behind non-stop on Down Leeds line, and can arrive York 3 minutes behind stopping service</p> <p><u>Up</u> A stopping service can follow 3 minutes behind non-stop from York on the Up Leeds line.</p>
York to Skelton Junction	3	3	
Skelton Junction to Northallerton	4 – Fast 5 – Slow	4 – Fast 5 – Slow	
King Edward Bridge South Junction to Heaton South Junction	3	3	
Benton North Junction Signal EG402/403	5*	5*	* May be 4 if Class 1 service is following Class 1 service. Also, trains can be 4 minutes apart passing Heaton South in either direction.

LN620 KING EDWARD BRIDGE EAST JUNCTION TO KING EDWARD BRIDGE NORTH JUNCTION			
TIMING POINT	DOWN	UP	NOTES
Standard Headway	TCB*	TCB*	*Plan as AB

LN626 NORTHALLERTON HIGH JUNCTION TO NORTHALLERTON EAST JUNCTION			
TIMING POINT	DOWN	UP	NOTES
Standard Headway	TCB*	TCB*	*Plan as AB

LN627 LONGLANDS JUNCTION TO NEWCASTLE EAST JUNCTION VIA THE COAST
Down Direction

HEADWAY AT	FOLLOW PASSENGER	FOLLOW TWM	FOLLOW FREIGHT	NOTES
Longlands Junction	n/a	n/a	3½	
Boroughbridge Road LC	n/a	n/a	3½	
Northallerton East Jn	4½	n/a	5½	
Yarm	5*	n/a	3½	*If 1 st train stopping Yarm; 3 if not
Eaglescliffe	4	n/a	4	
Stockton Cut Jn	4	n/a	4	
Hartburn Jn	4	n/a	4	
Norton South Jn	4	n/a	5	
Billingham Jn	AB	n/a	AB	
Greatham SB	5*	n/a	4	*If 1 st train stopping; 4 if not
Hartlepool	TCB treat as AB*	n/a	TCB treat as AB	*A train stopping Hartlepool can depart 4" after preceeding train but {2} required before Horden
Horden Sig 7137	TCB treat as AB*	n/a	TCB treat as AB	*Second train pass Horden 1" after passenger arrive/pass Seaham; 2" after freight from south pass Seaham. A freight from Seaham Harbour does not affect headway from Horden
Seaham	5	n/a	5	
Ryhope Grange Jn	5	n/a	5	
Sunderland	3	4	4	If 2 nd train freight, see margins
Boldon West/Brockley W	2½	3	3½	
Pelaw Metro Junction	n/a	3	n/a	
Pelaw Junction	5*	n/a	3	*If 1 st train stopping Heworth; 2 if not
Park Lane J (to Newcastle)	3	n/a	n/a	
High Level Bridge Jn	3	n/a	n/a	

LN627 LONGLANDS JUNCTION TO NEWCASTLE EAST JUNCTION VIA THE COAST
Up Direction

HEADWAY AT	FOLLOW PASSENGER	FOLLOW TWM	FOLLOW FREIGHT	NOTES
High Level Bridge Jn	2½	n/a	n/a	
Park Lane Junction	2½	n/a	5	
Pelaw Junction	2½	See margins	4½	
Pelaw Metro Junction	n/a	2½	n/a	
Boldon West/Brockley W	2½	2½	5½*	*High figure due to signaling restriction; see Margins
Sunderland	5	n/a	5	
Ryhope Grange Jn	5	n/a	5	
Seaham	TCB treat as AB*	n/a	TCB treat as AB*	*In Up Direction, 2 nd train can pass/depart Seaham 1" (passenger) 2" (freight going to Hartlepool) after 1 st train pass Horden. freight trains to Seaham Harbour can pass Seaham 5" after preceding train
Horden Sig 7148	6	n/a	7	
Hartlepool	5*	n/a	4	*If 1 st train stopping; 4 if not
Greatham SB	AB	n/a	AB	
Billingham Jn	4	n/a	6	
Norton South Jn	4	n/a	4	
Hartburn Jn	4	n/a	4	
Stockton Cut Jn	4	n/a	4	
Eaglescliffe	5½*	n/a	4	*If 1 st train stopping Yarm; 3½ if not
Yarm	5*	n/a	4½	*If 1 st train stopping Yarm; 4 if not
Northallerton East Jn	n/a	n/a	3½	
Boroughbridge Road LC	n/a	n/a	3½	

LN628 SOUTH HYLTON TO SUNDERLAND SOUTH JUNCTION			
TIMING POINT	DOWN	UP	NOTES
South Hylton to Sunderland	4	4	

LN631 DARLINGTON SOUTH JUNCTION TO EAGLESCLIFFE SOUTH JUNCTION			
TIMING POINT	DOWN	UP	NOTES
Standard Headway	5	5	

LN632 STOCKTON CUT JUNCTION TO SALTBURN			
TIMING POINT	DOWN	UP	NOTES
Standard Headway	4	4	
Exceptions:			
Middlesbrough to Redcar Central	5	5	
Redcar Central to Saltburn West Junction	8	8	
Saltburn West Junction to Saltburn	Single line		TCB

LN634 GUISBOROUGH JUNCTION TO WHITBY			
TIMING POINT	DOWN	UP	NOTES
Guisborough Jn to Nunthorpe	Single Line		TCB but treat as AB. See Restrictions at Nunthorpe
Nunthorpe to Battersby	Single Line		NSTR but treat as AB*
Battersby to Glaisdale	Single Line		NSTR but treat as AB*
Glaisdale to Whitby	Single Line		NSTR but treat as AB*. See Restrictions at Glaisdale and Whitby
Passing points:			
Nunthorpe			
Battersby			
Glaisdale			
*AB for Nunthorpe-Battersby-Glaisdale-Whitby must be 5 minutes arrive/depart. This is due to first driver at location 'x' having to walk to token box, unlock, and relinquish token; then driver at location 'y' having to phone signaller for permission to obtain token, lock token box, return to train, then conductor close doors, before train can depart			

LN642 SALTBURN WEST JUNCTION TO BOULBY POTASH MINE			
TIMING POINT	DOWN	UP	NOTES
Saltburn West Junction to Crag Hall	Single Line		TB
Crag Hall to Boulby	Single Line		NST

LN644 HARTBURN JUNCTION TO BOWESFIELD JUNCTION

TIMING POINT	DOWN	UP	NOTES
Bowesfield Junction to Hartburn Junction	TCB*	TCB*	* planned as AB

LN646 NORTON-ON-TEES SOUTH TO FERRYHILL SOUTH JUNCTION

TIMING POINT	DOWN	UP	NOTES
Norton-on-Tees South Jn to Norton-on-Tees West Jn	AB	AB	
Norton-on-Tees West Jn to Ferryhill South Jn	AB	AB	

LN652 BILLINGHAM JUNCTION TO SEAL SANDS STORAGE

TIMING POINT	DOWN	UP	NOTES
Billingham Jn. To Belasis Lane	AB	AB	
Belasis Lane to Port Clarence/Seal Sands	Single Line		NTS/OTS Working

LN664 BOLDON EAST JUNCTION TO BOLDON NORTH JUNCTION

TIMING POINT	DOWN	UP	NOTES
Boldon East Junction to Boldon North Junction	Single line		TCB

LN666 BOLDON WEST JUNCTION TO TYNE DOCK

TIMING POINT	DOWN	UP	NOTES
Boldon West Junction to Boldon North Junction	Single line		TCB
Boldon North to Green Lane Junction			Only one train in either direction between these locations
Green Lane Junction to Tyne Dock	Single line		Information only controlled by Port of Tyne

LN674 HIGH LEVEL BRIDGE JUNCTION GREENSFIELD JUNCTION

TIMING POINT	DOWN	UP	NOTES
Standard Headway	TCB*	TCB*	*Plan as AB

LN676 PARK LANE JUNCTION TO KING EDWARD BRIDGE SOUTH JUNCTION			
TIMING POINT	DOWN	UP	NOTES
Park Lane Junction to Greensfield Junction	TCB*	TCB*	*Plan as AB
Greensfield Junction to King Edward Bridge East Junction	TCB*	TCB*	*Plan as AB
King Edward Bridge East Junction to King Edward Bridge South Junction	TCB*	TCB*	*Plan as AB

LN678 DARLINGTON NORTH JUNCTION TO EASTGATE			
TIMING POINT	DOWN	UP	NOTES
Darlington to Heighington	Single line		TCB planned as AB
Heighington to Shildon	AB	AB	
Shildon to Bishop Auckland	Single line		TCB planned as AB. Bishop Auckland Jn (exculsive) to Eastgate controlled by the Weardale Railway who should be contacted for permission to access the line.

LN682 KING EDWARD BRIDGE SOUTH JUNCTION TO PETERIL BRIDGE JUNCTION			
TIMING POINT	DOWN	UP	NOTES
King Edward Bridge South Junction to Blaydon	4 following non-stop, 5 ½ following stopping	4 following non-stop, 5 ½ following stopping	
Blaydon to Wylam	AB	AB	
Wylam to Prudhoe	AB	AB	
Prudhoe to Hexham	7 following non-stop 10 following stopping	7 following non-stop 9½ following stopping	
Hexham to Haydon Bridge	AB	AB	
Haydon Bridge to Haltwhistle	AB	AB	
Haltwhistle to Low Row	AB	AB	
Low Row to Brampton Fell	AB	AB	
Brampton Fell to Corby Gates	AB	AB	
Corby Gates to Petheril Bridge Junction	4	AB	

LN684 LOW FELL JUNCTION TO NORWOOD JUNCTION

TIMING POINT	DOWN	UP	NOTES
Low Fell Junction to Norwood Junction	Single line		TCB

LN694 BENTON NORTH JUNCTION TO MORPETH NORTH JUNCTION VIA BEDLINGTON

TIMING POINT	DOWN	UP	NOTES
Morpeth to Bedlington North Junction	Single line		TCB planned as AB
Bedlington North Junction to Newsham	AB	AB	
Newsham to Benton North Junction	Single line		TCB planned as AB

LN696 HEPSCOTT JUNCTION TO MORPETH JUNCTION

TIMING POINT	DOWN	UP	NOTES
Hepscott Junction to Morpeth Junction	4	4	

LN700 BUTTERWELL NORTH BRANCH

TIMING POINT	DOWN	UP	NOTES
Butterwell Junction to Butterwell	Single Line		TCB planned as AB

LN702 BEDLINGTON NORTH TO LYNEMOUTH ALCAN

TIMING POINT	DOWN	UP	NOTES
Bedlington North to West Sleekburn Junction	AB	AB	
West Sleekburn Junction to Marchey's House Junction	AB	AB	
Marchey's House Junction to Ashington Junction	AB	AB	
Ashington Junction to Lynemouth Alcan/Power Station	AB	AB	

LN706 WEST SLEEBURN JUNCTION TO NORTH BLYTH

TIMING POINT	DOWN	UP	NOTES
West Sleekburn Junction to Winning Junction	AB	AB	
Winning Junction to Freeman's LC	AB	AB	
Freeman's LC to North Blyth	Single Line		See Section 5.3 for Method of Working

LN708 WINNING JUNCTION TO MARCHEY'S HOUSE JUNCTION			
TIMING POINT	DOWN	UP	NOTES
Winning Junction to Marchey's House Junction	AB	AB	

LN736 CLEETHORPES TO NUNNERY MAIN LINE JUNCTION VIA RETFORD			
TIMING POINT	DOWN	UP	NOTES
Cleethorpes to Brocklesby	<u>Down</u> 4 All stations can depart 3 minutes behind non-stop. <u>Up</u> 4 Non-stop can arrive 3 minutes behind all stations		
Brocklesby to Barnetby	5 DM 8 DG	4 5 Following Freight over 800 tonnes	
Barnetby to Wrawby Junction	4 Following Passenger 5 Following Freight	4 5 Following Freight over 800 tonnes	
Wrawby Junction to Brigg	6*	6*	* Single line TCB
Brigg to Kirton Lime Sidings	AB	AB	
Kirton Lime Sidings to Gainsborough Central	9**	8**	** Single line TCB Passing loop at Northorpe
Gainsborough Trent Junction to Retford	5	5	
Retford to Worksop	6	5	
Worksop to Brancliffe East Junction	4	4	
Brancliffe East Junction to Kiveton Park	TCB	TCB	To be planned as AB
Kiveton Park to Woodhouse Junction	AB	AB	
Woodhouse Junction to Woodburn Junction	AB	AB	
Woodburn Junction to Nunnery Main Line	4	4	

LN740 GRIMSBY MARSH WEST JUNCTION TO HUMBER ROAD JUNCTION			
TIMING POINT	DOWN	UP	NOTES
Marsh West Junction to Great Coates No. 1	AB	AB	
Great Coates No. 1 to Pyewipe Road SB	Single line		AB
Pyewipe Road SB to Immingham East Junction	One train in section		ETB
Immingham East Jn to Humber Road Jn	TCB	TCB	Planned as AB

LN741 HABROUGH JUNCTION TO ULCEBY SOUTH JUNCTION			
TIMING POINT	DOWN	UP	NOTES
Habrough Junction to Ulceby	4	4	

LN742 KILLINGHOLME TO BROCKLESBY JUNCTION			
TIMING POINT	DOWN	UP	NOTES
Killingholme to IW253 signal	Single line		OT(S)
Immingham West Jn to Ulceby	6	6	

LN744 ULCEBY NORTH JUNCTION TO BARTON ON HUMBER			
TIMING POINT	DOWN	UP	NOTES
Ulceby to Goxhill	AB	AB	
Goxhill to Oxmarsh Crossing	AB	AB	
Oxmarsh Crossing to Barton on Humber	Single line		OTS

LN750 WOODBURN JUNCTION TO DEEPCAR			
TIMING POINT	DOWN	UP	NOTES
Restriction:			
<ul style="list-style-type: none"> Tokenless One Train Working on Stocksbridge Line 			

LN752 WRABBY JUNCTION TO MARSHGATE JUNCTION			
TIMING POINT	DOWN	UP	NOTES
Standard Headway	4	4	
Exceptions:			
Wrawby Junction to Foreign Ore Branch Junction	4 Following Passenger 5 Following Freight	4 5 Following Freight over 800 tonnes	
Kirk Sandall Junction to Doncaster	4 3 Stopping Pass'r or Freight following non-stop	4	

LN756 SCUNTHORPE TRENT JUNCTION TO ROXBY			
TIMING POINT	DOWN	UP	NOTES
Standard Headway	Single Line		Staff Working

LN758 BRANCLIFFE EAST JUNCTION TO KIRK SANDALL JUNCTION			
TIMING POINT	DOWN	UP	NOTES
Branscliffe East Junction to WP605 Signal	AB		
WP605 Signal to Dinnington Junction	AB		
Branscliffe East Junction to WP606 Signal		AB	
WP606 Signal to Dinnington Junction		AB	
Dinnington Junction to Maltby Colliery SB	Single Line		TB planned as AB
Maltby Colliery SB to Firbeck Junction	Single Line		TB planned as AB
Firbeck Junction to St Catherines Junction	Single Line		TCB planned as AB
St Catherines Junction to Kirk Sandall Junction	Single Line		TCB

LN766 BENTLEY JUNCTION TO HEXTHORPE JUNCTION (DONCASTER AVOIDING LINE)			
TIMING POINT	DOWN	UP	NOTES
Standard Headway	5	5	

LN768 MANSFIELD WOODHOUSE TO SHIREOAKS EAST JUNCTION			
TIMING POINT	DOWN	UP	NOTES
Mansfield Woodhouse to Shirebrook Jn	AB	AB	
Shirebrook Jn to Shireoaks East Jn	AB	AB	Elmton & Creswell Signal Box is in situ but switched out. If required for timeble purposes Elmton & Creswell Signal Box can be opened outside normal opening box times.

LN774 BARROW HILL NORTH JUNCTION TO OXCROFT DISPOSAL POINT			
TIMING POINT	DOWN	UP	NOTES
Standard Headway	Single line		OTS

LN784 HIGH MARNHAM TO SHIREBROOK EAST JUNCTION			
TIMING POINT	DOWN	UP	NOTES
Standard Headway	AB	AB	
Exceptions:			
High Marnham to Boughton Junction	Single line		OTS

LN786 BEVERCOTES COLLIERY BRANCH			
TIMING POINT	DOWN	UP	NOTES
Bevercotes Colliery to Boughton Junction	Single line		Out of use

LN804 TAPTON JUNCTION TO GASCOIGNE WOOD JUNCTION VIA SHEFFIELD			
TIMING POINT	DOWN	UP	NOTES
Tapton Junction to Dore Station Junction	4	4	
Dore Station Junction to Sheffield	4	4	<u>Down</u> Trains stopping at Dore or signal stop at Dore may be 3 minutes behind at Dore Station Jn <u>Up</u> Trains may depart 3 minutes apart from Sheffield but must be 4 minutes behind at Dore Station Jn
Sheffield to Nunnery Main Line Junction	3	3	<u>Down</u> 2½ when preceding/following train to Woodburn Junction <u>Up</u> 2½ when preceding/following train from Woodburn Junction
Nunnery Main Line Junction to Wincobank Junction	3	3	
Wincobank Junction to Holmes Junction	3	3	<u>Up</u> 2½ from Rotherham Central when following non-stop
Holmes Junction to Swinton	3	3	
Swinton to Ferrybridge North Junction	4	4	
Ferrybridge North Junction to Milford Junction	4 Passenger 6 Freight	4 Passenger 6 Freight	
Milford Junction to Church Fenton	4	5	

LN806 TAPTON JUNCTION TO MASBOROUGH JUNCTION VIA 'OLD ROAD'			
TIMING POINT	DOWN	UP	NOTES
Standard Headway	4	4	

LN807 DORE SOUTH JUNCTION TO DORE WEST JUNCTION			
TIMING POINT	DOWN	UP	NOTES
Standard Headway	Single line		TCB

LN808 DORE STATION JUNCTION TO TOTLEY TUNNEL EAST			
TIMING POINT	DOWN	UP	NOTES
Dore Station Jn to Dore West Jn	Single line		TCB
Dore West Jn to Totley Tunnel East	4	4	

LN809 SHEPCOTE LANE WEST JUNCTION TO TINSLEY YARD EAST END			
TIMING POINT	DOWN	UP	NOTES
Standard Headway	Single line		TCB

LN814 TINSLEY NORTH JUNCTION TO SHEFFIELD TRAM TRANSFER LINE			
TIMING POINT	DOWN	UP	NOTES
Standard Headway	Single line		TCB

LN815 PARKGATE JUNCTION TO SHEFFIELD TRAM PARKGATE TRANSFER			
TIMING POINT	DOWN	UP	NOTES
Standard Headway	Single line		TCB

LN816 BEIGHTON JUNCTION TO WOODHOUSE JUNCTION			
TIMING POINT	DOWN	UP	NOTES
Standard Headway	4	4	

LN818 HOLMES JUNCTION TO ROTHERHAM CENTRAL			
TIMING POINT	DOWN	UP	NOTES
Standard Headway	Single line		TCB

LN826 DONCASTER SOUTH YORKSHIRE JUNCTION TO SWINTON			
TIMING POINT	DOWN	UP	NOTES
Standard Headway	4	4	
Exceptions:			
Doncaster to Hexthorpe Jn	4	4	<u>Down</u> 3 stopping Passenger or Freight following non-stop from Doncaster <u>Up</u> 3 non-stop can arrive behind stopping Passenger at Doncaster

LN828 MEXBOROUGH JUNCTION TO ALDWARKE JUNCTION VIA KILNHURST			
TIMING POINT	DOWN	UP	NOTES
Standard Headway	Single line		TCB

LN830 ALDWARKE JUNCTION TO WOODBURN JUNCTION			
TIMING POINT	DOWN	UP	NOTES
Standard Headway	4	4	
Exceptions:			
Tinsley East Junction to Woodburn Junction	Single	Line	TCB to be planned as AB

LN836 DONCASTER MARSHGATE JUNCTION TO NEVILLE HILL EAST JUNCTION			
TIMING POINT	DOWN	UP	NOTES
Standard Headway	4	4	
Exceptions:			
South Kirkby Junction to Hare Park Junction	4	4	<u>Down</u> 3 from Branch following train from Doncaster at South Kirkby Jn. 2 if from a stand
Wakefield Westgate to Holbeck Junction	4	4	<u>Down</u> 3½ on approach to Holbeck Jn if 1 st train has an excess of pathing, engineering or performance allowances. <u>Up</u> 3½ Loco hauled or stopping DMU following electric service
Armley Junction to Leeds	2½	2½	A and B Lines Only
Armley Junction to Whitehall Jn	3	3	C and D Lines Only
Holbeck Junction to Leeds	3	3	
Leeds West Junction to Leeds	2	2	E and F Lines Only
Leeds to Neville Hill East Junction	4	4	<u>Down</u> A stopping service can follow 3 minutes behind non-stop from Leeds. <u>Up</u> A non-stop can arrive Leeds 3 minutes behind stopping service

LN838 LEEDS ARMLEY JUNCTION TO YORK SKELTON JUNCTION VIA HARROGATE			
TIMING POINT	DOWN	UP	NOTES
Standard Headway	AB	AB	
Exceptions:			
Poppleton to Hammerton	Single line		ET
Cattal to Knaresborough	Single line		ET
Harrogate to Horsforth	6½* 8*	6½* 8*	Following Non-Stop service Following Stopping service *Please refer to Harrogate station under junction margins for exceptions to the headways listed
Horsforth to Armley Junction	5	4½	
Armley Junction to Leeds	2½	2½	A and B Lines Only. See also LN836 for other headways west of Leeds.

LN842 THORPE MARSH JUNCTION TO ADWICK JUNCTION

TIMING POINT	DOWN	UP	NOTES
Standard Headway	4	4	

LN848 HARE PARK JUNCTION TO CROFTON WEST JUNCTION

TIMING POINT	DOWN	UP	NOTES
Standard Headway	4	4	

LN850 WAKEFIELD WESTGATE SOUTH JUNCTION TO WAKEFIELD KIRKGATE WEST JUNCTION

TIMING POINT	DOWN	UP	NOTES
Standard Headway	Single line		TCB

LN852 HOLBECK JUNCTION TO BRADFORD INTERCHANGE

TIMING POINT	DOWN	UP	NOTES
Standard Headway	5	5	

Exceptions:

Mill Lane Junction to Bradford Interchange	3½ – train from Halifax followed by train from Leeds 2½ – train from Leeds followed by train from Halifax	2 – trains diverging at Mill Lane Junction	
--	--	--	--

LN854 HALL ROYD JUNCTION TO COLTON JUNCTION			
TIMING POINT	DOWN	UP	NOTES
Standard Headway	5	5	
Hall Royd Jn. To Hebden Bridge	4	4	
Hebden Bridge to IBS signals HB7/MR8	AB	AB	
IBS signals HB7/MR8 to Milner Royd Junction	AB	AB	
Greetland Junction to Bradley Wood Junction	4½	4½	
Heaton Lodge/Heaton Lodge East Junction to Thornhill LNW/Mirfield East Junctions to Dewsbury	2½*	2½*	<i>Section also appears in LN860</i> *Down. 3 following freight going towards Healey Mills *Up. 4 on US
Thornhill LNW Junction to Horbury Junction	5	6	
Horbury Junction to Wakefield Kirkgate	5	6	
Wakefield Kirkgate to Whitwood Junction	4	5*	*A train may pass Altofts Junction 2 minutes before a service passes Turners Lane Junction towards Calder Bridge Junction
Whitwood Junction to Castleford	3 Pass 4 Freight	3 Pass 4 Freight	
Castleford to Milford Junction	6 Pass 10 Freight	6 Pass 10 Freight	Maximum of 2 trains between Castleford and Milford Junction at the same time.
Church Fenton North Junction to Colton Junction	4	4	

LN858 MILNER ROYD JUNCTION TO MILL LANE JUNCTION			
TIMING POINT	DOWN	UP	NOTES
Milner Royd Junction to Halifax	5	5½	
Halifax to Mill Lane Junction	6 \$ following non stop 7½ \$ # following stopping	6 Following non stop 7½ Following Stopping	\$ Trains can be 5 minutes apart at Mill Lane Junction # Headway following a stopping train can be reduced to 6 minutes provided that at least 1½ minutes pathing time is added before Mill Lane Junction

LN860 DIGGLE JUNCTION TO COPLEY HILL EAST JUNCTION : Down Direction

HEADWAY AT	FOLLOWING NON-STOP	FOLLOWING STOPPER	NOTES
Diggle Junction	See notes	See notes	This section is TCB. It is operated as one section Marsden to Diggle Junction as though it were AB
Marsden	4	4	
Huddersfield (arriving)	4*	4*	*3½ if arriving at different platforms
Huddersfield (depart)	4*	4	*2½ if calling at Deighton and/or diverging at Bradley Junction, following non-stop; 3½ consecutive fasts Huddersfield if coming from different platforms
Bradley Junction	2½	4	
Heaton Lodge East Jn	2½*	3	*3 following freight going towards Healey Mills
Mirfield East Junction	2½	3	
Dewsbury	3	3½	
Morley	4	4	
Trains maybe timed 3 minutes apart at Whitehall Junction			

LN860 COPLEY HILL EAST JUNCTION TO DIGGLE JUNCTION : Up Direction

HEADWAY AT	FOLLOWING NON-STOP	FOLLOWING STOPPER	NOTES
Whitehall Junction	3	4	
Morley	4½	5½*	*5 if class 185 stopping at Morley
Dewsbury	2½	2½	
Thornhill LNW Junction	2½	2½	
Mirfield East J (FL)	2½	4	
Mirfield East J (SL)	4	4	
Heaton Lodge Junction	2½	3	
Bradley Junction	2½	3	
Huddersfield (arriving)	2½	2½	
Huddersfield (depart)	4	4	
Marsden (arriving)	-	4½	
Marsden (departing)	See notes	See notes	This section is TCB. It is operated as one section Diggle Junction to Marsden as though it were AB (Second train can depart Marsden 1 after first train has passed Diggle)

LN862 BARNSELY STATION JUNCTION TO HUDDERSFIELD

TIMING POINT	DOWN	UP	NOTES
Standard Headway	Single line		TCB
Exceptions:			
Clayton West Junction to Stocksmoor	AB	AB	

LN868 WINCOBANK JUNCTION TO HORBURY JUNCTION VIA BARNSELY

TIMING POINT	DOWN	UP	NOTES
Wincobank Junction to Ecclesfield West	5	5	
Ecclesfield West to Barnsley	8	8	
Barnsley to Horbury Junction	8	8	

LN872 ALTOFTS JUNCTION TO LEEDS WEST JUNCTION

TIMING POINT	DOWN	UP	NOTES
Standard Headway	4	4	

LN874 METHLEY JUNCTION TO WHITWOOD JUNCTION

TIMING POINT	DOWN	UP	NOTES
Standard Headway	3	3	

LN875 CASTLEFORD WEST JUNCTION TO PONTEFRACT WEST JUNCTION

TIMING POINT	DOWN	UP	NOTES
Standard Headway	5 Pass 6 Freight	5 Pass 6 Freight	

LN880 YORK TO SCARBOROUGH

TIMING POINT	DOWN	UP	NOTES
York to Strensall	6	6	
Strensall to Barton Hill	AB	AB	
Barton Hill to Kirkham Abbey	AB	AB	
Kirkham Abbey to Malton	AB	AB	
Malton to Weaverthorpe	AB	AB	
Weaverthorpe to Seamer	AB	AB	
Seamer to Scarborough	3½	3½	

LN882 WAKEFIELD KIRKGATE WEST JUNCTION TO GOOLE POTTER'S GRANGE JUNCTION

TIMING POINT	DOWN	UP	NOTES
Standard Headway	4	4	
Exceptions:			
Wakefield Kirkgate to Oakenshaw Junction	3	3	
Pontefract East Goods Junction to Knottingley West Junction	3	3	
Knottingley East Junction to Drax Branch Junction	5 Pass 6 Freight	5 Pass 6 Freight	
Drax Branch Junction to Goole	Single line		TCB planned as AB

LN886 MONK BRETTON LOOP TO CROFTON EAST JUNCTION			
TIMING POINT	DOWN	UP	NOTES
Standard Headway	Single Line		OTNS. Monk Bretton loop can only be used for a locomotive run round.

LN888 HATFIELD AND STAINFORTH (STAINFORTH JUNCTION) TO FERRYBRIDGE NORTH JUNCTION			
TIMING POINT	DOWN	UP	NOTES
Standard Headway	4	4	
Exceptions:			
Haywood Junction to Knottingley South Junction	4 Pass 6 Freight	4 Pass 6 Freight	

LN889 SHAFTHOLME JUNCTION TO HAYWOOD JUNCTION			
TIMING POINT	DOWN	UP	NOTES
Standard Headway	4	4	

LN896 DRAX POWER STATION BRANCH			
TIMING POINT	DOWN	UP	NOTES
Drax Branch Junction to Drax PS	6	6	

LN898 NEVILLE HILL EAST JUNCTION TO HULL			
TIMING POINT	DOWN	UP	NOTES
Standard Headway	4	4	
Exceptions:			
Selby West to Selby	3	4	
Selby to Gilberdyke	6 following non-stop. 8 following stopping train or Freight	4 following non-stop 6 following stopping train or Freight	
Gilberdyke to Broomfleet	AB	AB	
Broomfleet to Crabley Creek SB	AB	AB	
Crabley Creek SB to Brough East SB	AB	AB	
Brough East SB to Melton Lane	AB	AB	
Melton Lane to Hull	5 non-stop 3 stopping train arriving in front of non-stop	4 non-stop 3 stopping train following non-stop	

LN902 MICKLEFIELD JUNCTION TO CHURCH FENTON NORTH JUNCTION			
TIMING POINT	DOWN	UP	NOTES
Standard Headway	4	4	

LN910 TEMPLE HIRST JUNCTION TO SELBY SOUTH JUNCTION			
TIMING POINT	DOWN	UP	NOTES
Standard Headway	4	4	

LN912 THORNE JUNCTION TO GILBERDYKE JUNCTION			
TIMING POINT	DOWN	UP	NOTES
Standard Headway	4	4	
Exceptions:			
Saltmarshe to Gilberdyke	AB	AB	

LN914 HULL TO SEAMER WEST JUNCTION			
TIMING POINT	DOWN	UP	NOTES
Hull to Beverley	6	6	
Beverley to Driffield	AB	AB	
Driffield to Bridlington	AB	AB	
Bridlington to Hunmanby	Single line		TCB
Filey to Seamer	Single line		TCB

LN916 HESSLE ROAD JUNCTION TO SALTEND			
TIMING POINT	DOWN	UP	NOTES
Standard Headway Springbank South Jn to Dock Security Gates	Single line		TCB Section Split at Bridges Junction
Passing point			
Hessle Road Junction to Springbank South Junction			

LN922 WHITEHALL WEST JUNCTION TO HELLIFIELD SOUTH JUNCTION			
TIMING POINT	DOWN	UP	NOTES
Whitehall West Junction to Shipley	4	4	
Shipley to Keighley	4 (6 at Shipley following train stopping at Saltaire)	4 (6 at Keighley following train stopping at Crossflats)	
Keighley to Skipton	5	5 (6 at Skipton following train stopping at Connonley)	
Skipton to Gargrave	8½ following non-stop 10 following stopping	8½ following non-stop 10 following stopping	
Gargrave to Hellifield	AB	AB	

LN924 APPERLEY JUNCTION TO ILKLEY			
TIMING POINT	DOWN	UP	NOTES
Apperley Junction to Springs Junction	Single line		TCB
Esholt Junction to Guiseley	TCB	TCB	Planned as AB – SRT +1 minute
Guiseley to Burley-In-Wharfedale	TCB	TCB	Planned as AB – SRT +1 minute
Burley-In-Wharfedale to Ilkley	TCB		Planned as AB – SRT +1 minute
Ilkley to Ben Rhydding		TCB	Planned as AB – SRT +1 minute
Ben Rhydding to Burley-In-Wharfedale		TCB	Planned as AB – SRT +1 minute

LN926 DOCKFIELD JUNCTION TO ESHOLT JUNCTION			
TIMING POINT	DOWN	UP	NOTES
Standard Headway	Single line		TCB

LN928 SHIPLEY EAST JUNCTION TO BRADFORD FORSTER SQUARE			
TIMING POINT	DOWN	UP	NOTES
Standard Headway	4	4	

LN930 SKIPTON MIDDLE JUNCTION TO RYLSTONE			
TIMING POINT	DOWN	UP	NOTES
Skipton to Rylstone	Single line		OTNS

LN3214 BELLE ISLE TO CANAL TUNNEL JUNCTION			
TIMING POINT	DOWN	UP	NOTES
For Route LN3214 Please See East Midlands Timetable Planning Rules			

5.2.2 General Capacity Constraints

Where single line working is to operate or trains are to be routed to run on a line other than that normally planned for them, constraints on capacity will apply – see Rules of the Route.

The following special capacity and timing restrictions apply in addition to the constraints stated elsewhere in this document:

None

5.3 Junction Margins and Station Planning Rules

The definition for Junction Margins and Station Planning Rules is listed in Section 6.6 - 6.10 of the National TPRs.

All times shown are in minutes. Where adjustments to sectional running times are shown, the value must be added to the normal SRTs shown in B Plan. Negative adjustments are specially identified.

Minimum station allowances are the minimum practical for the particular type of stock. These are shown with exceptions being listed by line of route where applicable.

Light engine movements to be treated as passenger trains when applying margins/allowances where there is a passenger/freight differential.

STANDARD VALUES – MINIMUM	
Attachment of Locomotives/Units	
22x	7
DMU	6
EMU (gangwayed)	4
EMU (Non gangwayed)	3
EMU (Northern Trains)	7
Locomotive	15
Govia Thameslink Railway class 313/365/387 units	6
Connectional Allowance	
	5 minutes
Detachment of Locomotives/Units:	
22X	7
DMU	5
EMU (gangwayed)	3
EMU (non gangwayed)	2
EMU (Northern Trains)	7
Locomotive	10% % 12 if locomotive attached at other end of train
Govia Thameslink Railway class 313/365/387 units	5

Dwell Time	
DMU (E)	1
DMU (Other)	45 seconds. To be shown as alternating 1 and ½ minute stops
DMU reversing on through services	3* * 4 East Midlands Trains services
EMU	½
HST/LH/22X/180	1½
Tyne & Wear Metro cars	24 seconds. To be shown as ½ stop and SRT shortened by 6 seconds
Locomotive Change	
At same end	16
Locomotive Run–Round	
Passenger	16
Freight	20
Platform End Conflicts	
1 st train arrive to 2 nd train depart	1
Platform Re–occupation	
Following EMU/DMU in same direction	3
following EMU/DMU in opposite direction	5
Following LH/HST in same direction	4
Following LH/HST in opposite direction	6
Reversal	
No change in composition	8
HST 2+7 or 2+8 includes Serco New Measurement Train	7
HST 2+7 or 2+8 Re–manned	5
Turnround	
DMU*	4
* Where turnround times are specified at locations for trains from specific origins, request should be made to the Operational Planning Project Manager LNE, Network Rail for times from other locations as a longer turnround may apply.	
HST/LH	35
Terminating CrossCountry trains prior to ECS move to Depot – Safety Check Unit (SCU):–	
1 x 22X	8 SCU and depart in same direction as arrival
1 x 22X	10 SCU and depart in reverse direction to arrival
2 x 22X	15 SCU and depart in same direction as arrival
2 x 22X	20 SCU and depart in reverse direction to arrival
Minimum Platform standing allowance before passenger train departure of 22x after arriving ECS form depot(train preparation reasons)	
1 x 22x	15
2 x 22x	20
By exception, values may be reduced after discussion and agreement with CrossCountry	
3 car class 313	5
6 car class 313	6

4 car class 365	5
8 car class 365	6
12 car class 365	7
4 car class 387	8
8 car class 387	9
12 car class 387	10
8 car class 700	8
12 car class 700	10
6 car class 717	6

**THE FOLLOWING PAGES SHOW-THE EXCEPTIONS TO THESE STANDARD VALUES
EXCEPTIONS TO THE STANDARD VALUES:**

LN101 LONDON KING'S CROSS TO SHAFTHOLME JUNCTION		
London King's Cross		
Connectional Allowance	15	
Junction Margins and Platform re- occupation – Crossing via Throat		
Depart/Arrive Platforms 1 – 8	5	
Depart/Arrive Platforms 9 – 11	4	
Arrive/Depart	2*	
	* May be reduced to 1 if both trains are EMUs	
Minimum Turnround		
	All Times	
Suburban EMU	7*	* 8 minutes if from north of Cambridge
From Yorkshire and stations south there of (VTEC)	30	
From Newcastle	35	
From Scotland	40	
From Hull (Hull Trains)	30 20 for arrivals during the following hours: Monday to Friday 0700 – 1000hrs and 1600 – 1900hrs Saturday All day Sunday 1700 – 2100hrs	
From Sunderland (Grand Central)	35 20 for arrivals originating from York during contingency timetable 20 for weekend trains subject to engineering diversions	
Station Working		
Platform 1. Trains starting from Platform 1 using signal K287 must depart via FL2 to Belle Isle and then FL to Holloway. Trains required to depart via FL1 must start behind K285 signal.		
Station Watering Points	Platforms 0 – 11	

Belle Isle Junction		
Note : It is not permissible for up trains to have any pathing,engineering or performance allowances between Belle Isle Junctions and King's Cross as there are no signals in this section.		
Junction Margins		
All crossing margins	3 minutes	

Copenhagen Junction

Note: Trains in the Down direction on the North London Incline (NLI) should not normally be shown to stop at Copenhagen Junction. Down trains required to stop on the NLI to wait a path over Copenhagen Jn should be timed to stop at York Way North Jn unless they exceed 630 metres in length. Only trains in excess of 630 metres in length should be timed to stop at Copenhagen Jn. In those circumstances due to signalling constraints the following applies: A Down train on the NLI planned to stop at Copenhagen Jn must arrive a minimum of 5 minutes before the passage of any train on the Down Slow

Junction Margins

First Movement	Second Movement	Margin
Train from NLI to Down Slow Line	Train from Up Slow Line to North London Incline	5
Train from Up Slow Line to North London Incline	Train passing on Down Slow	4½
Train passing on Down Slow	Train from Up Slow Line to North London Incline	4

Holloway South Junction

Adjustment to sectional running times

Movement Down	Reason	Value
Belle Isle to Holloway South Jn	DF or DS to DG pass to pass, approach control and differential junction speed	½

Movement Up	Reason	Value
Holloway South Jn to Belle Isle	US2 to UF or US pass to pass	½

Junction Margins

First Movement	Second Movement	Margin
Up train passes Belle Isle	Pass from SL2	1½
Up trains cross to/from SL	Next train passes Finsbury Park	2 [^]
Down train cross to SL/FL	Next train passes Belle Isle	1½
Down train cross to GL	Next train passes Belle Isle	2
Down FL train pass Finsbury Park	Cross from DSL to DFL	1½*

[^] - May be 1½ if 2nd train is also crossing to/from SL

* - May be 1 if 2nd train is calling at Finsbury Park

Finsbury Park

Dwell Time

Class 313, 365 and 387	1
Class 700 and 717	1½ May be reduced to one minute by TOC agreement

Junction Margins

First Movement	Second Movement	Margin
Depart Platform 7 to DSL	Depart platform 8 to DSL	2
Arrive USL from UFL	Pass UFL	2½
Depart Platform 4 to DFL	Arrive Platform 4 from UFL	4
Pass DFL	Depart DSL to DFL	1½ [^]
Pass DFL	Pass DSL to DFL	2 ^{\$}

Finsbury Park		
*		
\$ May be 1½ if second train has 1 minute or more pathing time approaching Finsbury Park		
^ Headway passing Alexandra Palace may be reduced to 2½ minutes.		
Platform Re-occupation		
In same direction	2½	
Adjustments to Sectional Running Times		
Movement Up	Reason	Value
Alexandra Palace to Finsbury Park	UF to US (all movements) Approach Control and Differential Junction Speed	1 EMU 1½ HST/LH/ 180/225
Movement Down	Reason	Value
Finsbury Park to Alexandra Palace	DS to DF (all movements) Differential Junction Speed	½

Harringay		
Junction Margins		
First Movement	Second Movement	Margin
Depart US2 (K85) to Hornsey EMUD	Arrive/Pass Finsbury Park	5

Alexandra Palace		
Adjustments to Sectional Running Times		
Movement Down	Reason	Value
Finsbury Park to Alexandra Palace	DF to Down Hertford and also DF to DS pass to pass; approach control and differential junction speed	1 EMU 1½ HST/LH/ 180/225/*
	DF to Down Hertford and also DF to DS start to pass	1
	DS to Down Hertford also DS to DF pass to pass	½
Alexandra Palace to Potters Bar	DF to DS pass to pass	1
	DS to DF pass to pass	1 180/EMU 1½ HST/LH/ 225
Movement Up	Reason	Value
Potters Bar to Alexandra Palace	US to UF pass to pass; approach control and differential junction speed	1 Except HST/225 1½ HST/225
	US1 to US2 pass to pass; approach control and differential junction speed	½ EMU
Alexandra Palace to Finsbury Park	Up Hertford to UF pass to pass; differential junction speed	1 180/EMU 1½ HST/LH/ 225
	Up Hertford to US pass to pass; differential junction speed	½ 180 1 HST/LH/ 225

Alexandra Palace		
	US1 to UF pass to pass; differential junction speed	1 180/EMU 1½ HST/LH
	US2 to US pass to pass; differential junction speed	½ EMU
	For services departing from Bounds Green Depot to US2 Start to pass; for acceleration purposes	1½ HST/LH
Junction Margins		
First Movement	Second Movement	Margin
Pass DFL	Depart DSL to DFL	1½
Pass DFL	Pass DSL to DFL	2*
Arrive/pass DSL from DFL	Pass DFL	3
Pass UFL	Pass USL to UFL	2*
Pass UFL	Depart USL to UFL	1½
Pass USL	Depart USL2 to USL	1½
Pass USL	Pass USL2 to USL	2*
Depart USL not calling at Hornsey	Depart USL2 to USL calling at Hornsey	2
Pass USL2	Pass USL to USL2	2*
* May be reduced to 1½ if second train has 1 minute or more pathing time approaching Alexandra Palace		
Dwell Time		
1 Up peak Trains arriving King's Cross/Moorgate /St Pancras International 0700 – 0959 SX 1 Down peak Trains departing King's Cross/Moorgate/ St Pancras International 1600 – 1859 SX		
Platform Re-occupation		
In same direction	2½	

New Southgate		
Junction Margins		
First Movement	Second Movement	Margin
Cross UFL to USL	Up fast passes Potters Bar	Same time

New Barnet		
Junction Margins		
First Movement	Second Movement	Margin
Down train to cross to SL	Next fast train passes Alexandra Palace	½
Up train cross to SL	Next train passes Potters Bar	1
Fast passes Alexandra Palace	Depart USL to UFL	1 before
Fast passes Alexandra Palace	Pass USL to UFL	Same time
Fast passes Potters Bar	Depart/pass DSL to DFL	Same time
Dwell Time		
1 Up peak Trains arriving King's Cross/Moorgate / St Pancras International 0700 – 0959 SX		

New Barnet
1 Down-peak Trains departing King's Cross/Moorgate / St Pancras International 1600 – 1859 0700 0959-SX

Potters Bar		
Adjustment to sectional running times		
Movement Down	Reason	Value
Alexandra Palace to Potters Bar	DF to DS pass to pass and pass to stop; approach control and differential junction speed	½
	DS to DF pass to pass and pass to stop; approach control and differential junction speed	½ EMU 1HST/LH/ 180 /225
Potters Bar to Welwyn Garden City	DF to DS pass to pass and pass to stop	1
	DS to DF pass to pass	1 EMU/180 1½ HST/LH/ 225
Movement Up	Reason	Value
Welwyn Garden City to Potters Bar	UF to US pass to pass; approach control and differential junction speed	1
	US to UF pass to pass; approach control and differential junction speed	1
Potters Bar to Alexandra Palace	UF to US pass to pass	1
	US to UF pass to pass	½ EMU/180 1 HST/LH/ 225
Junction Margins		
First Movement	Second Movement	Margin
Down train to cross to SL	Before next fast train passes Down Fast	2½
Up train cross UFL to USL	Before next fast train passes	3½
Pass UFL	Depart USL to UFL	1½
Pass UFL	Pass USL to UFL	2½
Pass DFL	Depart DSL to DFL	1½
Pass DFL	Pass DSL to DFL	2

Marshmoor Crossover		
Junction Margins		
First Movement	Second Movement	Margin
Up train arrive Welham Green	Pass USL to UFL	3
Up Fast Potters Bar	Pass USL to UFL	Same time

Hatfield		
Junction Margins		
First Movement	Second Movement	Margin
Cross to USL at Hatfield North	Before next train passes Welwyn Garden City	1½
Down fast pass Welwyn G.C.	Pass DSL to DFL	1

Welwyn Garden City		
Adjustment to sectional running times		
Movement Down	Reason	Value
Potters Bar to Welwyn Garden City	DF to DS pass to pass; approach control and differential junction speed	1
	DS to DF pass to pass; approach control and differential junction speed	1
Potters Bar or Hatfield to Welwyn Garden City	DS to DF pass to pass	1 180/EMU 2 HST/LH/ 225
Movement Up		
Woolmer Green to Welwyn Garden City	UF to US pass to pass; approach control and differential junction speed	1
	US to UF pass to pass	1 EMU/180 2 HST/LH/ 225
Connectional Allowance	4	
Dwell Time		
Class 313, 365 and 387	1	
Class 700 and 717	1½	
Junction Margins		
First Movement	Second Movement	Margin
Cross to DSL	Pass DFL	3
Pass DFL	Depart DSL to DFL	2
Pass UFL	Depart USL to UFL	2
Cross to USL	Pass UFL	3
Depart Yard	Pass Up/Down	5
Pass Up/Down	Depart Yard	2
GTR class 387, 700 and 717 trains to Welwyn Garden City CS require a 4 minute operational stop in the platforms to clear the train of passengers and lock the doors		
GTR Class 313 and 365 trains to Welwyn Garden City CS require a 5 minute operational stop in the platforms to close windows, clear the train of passengers and lock the doors		
This is to permit station staff to ensure windows are closed prior to the train passing through the carriage washer		
Turnrounds	All shunt movements to be timed	
Platform Re-occupation		
In either direction	3	

Digswell		
Junction Margins		
First Movement	Second Movement	Margin
Up train to cross to SL	Up fast passes Welwyn Garden City	3½
Down Fast train passes Welwyn Garden City	Pass DSL to DFL	2½*
Down Fast train passes Welwyn Garden City	Depart from USL	2
* May be reduced to 1½ mins for trains with pathing allowance after Welwyn Garden City and calling at Welwyn North		

Welwyn North
Station Working
For trains booked to call at Welwyn North a public/working differential (up to a maximum value of 3 minutes) equal to any pathing time approaching Digswell (down) and Woolmer Green (up) is to be applied

Woolmer Green		
Adjustments to Sectional Running Times		
Movement Down	Reason	Value
Approaching Woolmer Green Jn	DF – DS when DF from Welwyn GC; differential junction speed	½ HST/180/225
Movement Up	Reason	Value
After Woolmer Green Jn	US – UF when UF to Welwyn GC; differential junction speed	½ HST/180/225
Junction Margins		
First Movement	Second Movement	Margin
Down train to cross to SL	Next train pass	3
Pass UFL	Pass from USL	2

Stevenage		
Adjustments to Sectional Running Times		
Movement Down	Reason	Value
Stevenage to Hitchin	DF to DS pass to pass; junction differential	½ 180 /EMU 1 HST/LH/ 225
	DS to DF pass to pass (use for Hertford diversions)	1 180/EMU 1½ HST/LH/ 225
	US or UF to DF (for originating trains at during engineering works); differential junction speed	½
Woolmer Green to Stevenage	DF to DS pass to pass; approach control and differential junction speed	1
	DF to DS pass to stop; approach control and differential junction speed	½
	DS to DF pass to pass; approach control and differential junction speed	½ 180 /EMU 1 HST/LH/ 225
Movement Up	Reason	Value
Hitchin to Stevenage	UF to US pass to pass (use for Hertford diversions); approach control and differential junction speed	1 EMU 1½ HST/LH 180/225
	UF to US pass to stop (use for Hertford diversions); approach control and differential junction speed	½ HST/LH/ 180
	US to UF pass to pass; approach control and differential junction speed	1
Stevenage to Woolmer Green	UF to US pass to pass	1
	US to UF pass to pass	1 180/EMU 1½ HST/LH/

Stevenage		
		225
Connectional Allowance	4	
Dwell Time		
Class 313, 365 and 387	1	
LH/HST/222	1½	
Class 700 and 717	1½ May be reduced to 1 minute by TOC agreement	
Junction Margins		
First Movement	Second Movement	Margin
Cross to DSL	Pass DFL	3
Cross to USL	Pass UFL	3
Pass DFL	Depart DSL to DFL	2
Pass DFL	Pass DSL to DFL	2½*
Pass UFL	Depart USL to UFL	2
Pass UFL	Pass USL to UFL	2½*
Depart USL to UFL	Arrive/Pass UFL	3
Depart DSL in Up direction	Arrive DSL	6
Depart DSL in Up direction	Arrive DSL from DML	4
* May be reduced to 2 minutes if second train has 1 or more minutes pathing time approaching Stevenage		
Platform Re-occupation		
In same direction	3	
Station Working		
Up trains must be routed SL from Hitchin if UFL platform at Stevenage is occupied by an originating down passenger service.		
Turnround	Suburban EMU services turning round in platform 4 : 8 maximum SX, 10 maximum SO	

Hitchin		
Adjustments to Sectional Running Times		
Movement Down	Reason	Value
Stevenage to Hitchin	DF to Cambridge (via DCF) pass to pass; approach control and differential (EMU differential included in the SRT)	1 HST/LH/ /225 Also see 5.1
	DF to Cambridge (via flat junction) pass to pass; approach control and differential	½ EMU 1 HST/LH/225
	DF to DS pass to pass crossing at Hitchin South Jcn; junction differential	½
	DS to DF or Cambridge (via flat junction) pass to pass; approach control and differential	½ /EMU 1 HST/LH/ 225
	DS to DF pass to pass	1 222/EMU 1½ HST/LH/ 225

Hitchin		
Movement Up	Reason	Value
Sandy to Hitchin	UF to US pass to pass; approach control and differential	1½ EMU 2 HST/LH/ 180/225
	US to UF pass to pass; approach control	1
Hitchin to Stevenage	UF to US pass to pass	½
	Up Cambridge to Up Fast pass to pass; differential	1 EMU 2 HST/LH/ 180 /225
	US to UF pass to pass crossing at Hitchin South Jn ; differential	1 HST/LH 180/225/365
Connectional Allowance 4		
Dwell Time		
EMU	1 * May be reduced to ½ minute by agreement with Train Operator	
Junction Margins		
First Movement	Second Movement	Margin
Arrive USL from UFL	Pass Up Main	4
Pass UFL	Pass from USL to UFL	2
Down train to depart towards Royston	Before next fast Up or Down passes	3½
Depart to Royston	Arrive from Peterborough	3½
Down or Up fast passes	Depart to Royston	1*
Arrive DSL from DFL	Pass DFL	2½
Pass Up Fast/Up Slow	Pass to Royston	3
Pass to Royston	Pass Up Main	3
Pass to Royston via Flyover	Down Pass at Hitchin	3
Pass to Royston via Flyover	Depart to Sandy	3
* 1½ minutes when train on Down Slow arrives exactly same time as train passes Down Fast		
Platform Re-occupation		
In same direction	3	
Simultaneous moves not permitted		
A train may not arrive at the Down Slow platform 2 while a train is signalled from K699 signal on the Down Fast to the Down Slow(via 2271 crossover unless both trains have {1} on approach to Hitchin as they will both be approach controlled at Hitchin South Jn. Otherwise a margin of 2 minutes is required.		
A train may not cross from K699 signal on the Down Fast to the Down Slow (via 2271 crossover) while a train is arriving at platform 2 unless both trains have {1} on approach to Hitchin, as both trains will be approach-controlled at Hitchin South Jn. Otherwise a margin of 2 minutes is required		

Cadwell		
Adjustments to Sectional Running Times		
Movement Down	Reason	Value
Up Fast passes Hitchin	Cross USL to UFL	1

Arlesey		
Dwell Time		
	1 Down peak Trains departing King's Cross/Moorgate / St Pancras International 1600 – 1859 SX	

Biggleswade		
Junction Margins		
First Movement	Second Movement	Margin
Down train cross to DFL to DSL	Next Down fast train pass on DFL	2
Depart/Pass UFL to USL	Next Up fast train pass on UFL	2½
Arrive DS from US	Depart US or UF to Hitchin	Same time
Arrive DS from US	Pass on US	1½
Arrive DS from US	Pass on UF	1½
Arrive DS from US	Pass on DF	2
Arrive DS from US	Down arrive platform 3	3½
Arrive Plasmor	Pass on DS	2½
Arrive Plasmor	Down arrive Biggleswade	2½
Pass UF	Depart DS to Up	2
Pass UF	Depart K235 to DS	2
Depart platform 2 to UF	Depart DS to Up	2
Depart platform 2 to UF	Depart K235 to DS	2
Pass DF	Depart DS to Up	1
Pass DF	Depart K235 to DS	1
Pass DS	Depart Plasmor	2
Pass DS	Depart K235 to DS	2
Down depart on DS.	Depart Plasmor	2½
Down depart on DS	Depart K235 to DS	2½
US pass	Depart DS to US	2
US depart	Depart DS to US	2½
Depart DS to Up	Pass DS	4
Depart DS to Up	Arrive DS	4½
Depart DS to Up	Pass DF	4
Depart DS to US	Pass UF	4
Adjustments to Sectional Running Times		
Movement Down	Reason	Value
Hitchin to Biggleswade. To be applied approaching Biggleswade	DF to DS ; approach control	1 for non stopping; ½ stopping at Biggleswade
Biggleswade to Sandy. To be applied after Biggleswade	DF to DS; acceleration from slow speed pointwork	½ for non stopping trains only
Movement Up	Reason	Value
Sandy to Biggleswade. To be applied approaching Biggleswade	UF to US; approach control	½
Biggleswade to Hitchin. To be applied after Biggleswade	UF to US; acceleration from slow speed pointwork	1 for non stopping trains only

METHOD OF WORKING TO/FROM PLASMOR SIDINGS

Method of Working from South, to Plasmor Sidings:

- Hitchin xx/xx
- Biggleswade [platform 4] arr xxRM00
- Biggleswade [platform 4] dep xxRM03
- Biggleswade Plasmor xxPR06½

Method of Working from North, to Plasmor Sidings:

- Sandy xx/xx
- Biggleswade [platform 1 or 2] xx/00
- Biggleswade Signal K235 arrive xxRM02
- Biggleswade Signal K235 depart xxRM04
- Biggleswade [platform 4] arrive xxPRRM07
- Biggleswade [platform 4] depart xxRM09
- Biggleswade Plasmor arrive xx:12½

Method of Working from Plasmor Sidings to South:

- Biggleswade Plasmor depart xxPR00
- Biggleswade [platform 4] arrive xxPRRM02
- Biggleswade [platform 4] depart xxRM04
- Hitchin xx/xx

Method of Working from Plasmor Sidings to North:

- Biggleswade Plasmor depart xx:00
- Biggleswade [platform 4] arrive xxOP02 (OP stop to allow GF operator to join train)
- Biggleswade [platform 4] depart xxOP07
- Sandy xx/xx

Notes:

- Run Rounds, if required, use the DSL. Planners must satisfy themselves that a 'window' of at least 10 minutes exists between other traffic to allow this to take place
- Siding Lengths:
- No. 1 Siding (adjacent to Down Slow): Complete siding 821yards/117slu; south, clear of 'A' ground frame 476yards/67slu; north, clear of 'B' ground frame and all points 85yards/12slu; between 'A' ground frame and 'B' ground frame 276yards/39slu
- No. 2 Siding (adjacent to no. 1 siding at south end) – 205yds/29slu [presently out of use]
- No. 3 Siding (adjacent to no. 1 siding at north end) – 213yards/39 slu
- No. 4 Siding (adjacent to no. 3 siding) – 213yards/39 slu
- No. 5 Siding (adjacent to no. 4 siding) – room for locomotive only

Sandy		
Adjustments to Sectional Running Times		
Movement Down	Reason	Value
Hitchin to Sandy	DF to DS pass to pass; approach control	1 EMU 2 HST/LH/ 180/225
	DS to DF pass to pass; differential	1
Sandy to Huntingdon	DF to DS pass to pass; approach control	1
	DS to DF pass to pass; differential	1 180/EMU 2 HST/LH/ 225
Movement Up	Reason	Value
Huntingdon to Sandy	UF to US pass to pass; approach control and differential	1 EMU 2 HST/LH/ 180/225
	US to UF pass to pass; differential	1
Sandy to Hitchin	UF to US pass to pass; approach control	1
	US to UF pass to pass; differential	1 180/EMU 2 HST/LH/ 225
Junction Margins		
First Movement	Second Movement	Margin
Down train pass FL to SL	Next DF train passes	3
Up train crosses FL to SL	Next UF train passes	3
Pass Up Fast	Depart USL cross UFL	2
Pass Down Fast	Depart DSL cross DFL	2

St Neots		
Dwell Time		
All trains	1	
Adjustments to Sectional Running Times		
Movement Down	Reason	Value
Sandy to St.Neots	DF to DS ; approach control	1 EMU
Junction Margins		
First Movement	Second Movement	Margin
Down train to clear to SL	Before next non-stop train passes Sandy	Pass Sandy ½ before 1 st train has cleared to SL at St Neots
Pass Up fast	Depart USL to UFL	1½ before fast passes Sandy

Huntingdon		
Adjustments to Sectional Running Times		
Movement Down	Reason	Value
Sandy to Huntingdon	DF to DS pass to pass ; approach control	1 EMU 2 HST/LH/ 180/225
	DS to DF pass to pass ; differential	1
Huntingdon to Holme	DF to DS pass to pass ; approach control	½ EMU 1 HST/LH/180/ 225
Movement Up	Reason	Value
Conington South Jn to Huntingdon	UF to US pass to pass ; approach control	½ EMU/Freight 1½ HST/LH/ 180/225
Dwell Time		
EMU: 1		
Junction Margins		
First Movement	Second Movement	Margin
Up train to arrive	Before next non stop train passes	3
Down train to clear to SL	Before next non stop train passes	3
Pass Down Fast	Depart DSL to DFL	1½
Empty EMU to arrive Up platform from DFL	Before next non stop train passes	3½
Depart Up Bay	Arrive Up Slow Platform	3
Arrive Up Bay from P33 signal	Arrive Up Slow Platform	3½
Platform Reoccupation	3 minutes	

Conington Loop		
Junction Margins		
First Movement	Second Movement	Margin
Pass Up Main	Depart Loop	3 after fast passes Conington South Jn

Conington South Junction		
Minimum Turnaround		
4 cars	5	
8 cars	6	
12 cars	7	
Junction Margins		
First Movement	Second Movement	Margin
Up train cross to SL	Before next Up fast train passes	4
Cross Down to Up	Before Down fast passes Holme	5
Cross Down to Up	After Down fast passes Holme	1
Cross Down to Up	After Up train passes	2

Holme Junction		
Adjustments to Sectional Running Times		
Movement Down	Reason	Value
After Holme Jn	DS – DF when DF to Peterborough; differential junction speed	1 HST/180/ 225
Junction Margins		
First Movement	Second Movement	Margin
Pass DFL	Pass from DSL	2½
Pass DFL	Depart from DSL	2

Fletton Junction		
Junction Margins		
First Movement	Second Movement	Margin
Down train to clear to SL	Before next non stop passes Holme	Same time
Pass Up Main	Pass/depart USL	3 after non- stop passes Peterborough
Pass Up Main	Pass/depart USL	4 after stopping train departs Peterborough

Peterborough		
Adjustments to Sectional Running Times		
Movement Down	Reason	Value
After Peterborough for departures from Platforms 2, 4 and 5 via USL towards Werrington Jn	Via slow speed connections	½ All
Connectional Allowance	8	
Dwell Time		
DMU/EMU	2	
LH/HST	2	
170	1½	
Junction Margins		
Conflicting moves 3 minutes unless listed below In the following tables, 'A' denotes a parallel move to Peterborough East, then normal headway. 'P' denotes a parallel move.		

Platforms 1, 2 and 3														
2 nd move → 1 st move ↓	Dep PI 1 to UF	Dep PI 1 to US	Dep PI 2 to UF	Dep PI 3 to UF	Pass PI 3 to UF	Dep PI 1 to DF	Dep PI 2 to DF	Arr PI 1 from DF	Arr PI 2 from DF	Arr PI 1 from UF	Arr PI 2 from UF	Arr PI 3 from UF	Arr PI 1 from US/WY	Arr PI 2 from US/WY
Depart PI 1 to UF	–	3	3	3	5	–	–	5	5	4	4	4	4	4
Depart PI 1 to US	3	–	P	P	P	–	–	5	P	–	–	P	4	–
Depart PI 2 to UF	3	P	–	3	5	–	–	5	5	P	4	4	P	4
Depart PI 3 to UF	3	P	3	–	–	–	–	5	5	P	P	4	P	P
Pass PI3 to UF	2	P	2	–	–	2	2	3	3	4	4	4	P	5
Depart PI 1 to DF	P	P	P	P	5	–	4	4	4	5	5	5	5	5
Depart PI 2 to DF	P	P	–	P	5	4	–	P	4	5	5	5	P	5
Arrive PI 1 from DF	–	–	2	2	4	–	P	–	3	4	P	4	–	4
Arrive PI 2 from DF	2	P	–	2	4	2	–	3	–	P	5	4	P	5
Arrive PI 1 from UF	–	–	P	P	4	–	2	3	P	–	4	4	–	3
Arrive PI 2 from UF	2	P	–	2	4	2	–	3	4	4	–	4	P	4
Arrive PI 3 from UF	2	P	2	–	–	1	1	3	3	4	4	–	P	3
Arrive PI 1 from US/WY	1	1	P	P	P	–	P	4	P	4	P	P	–	–
Arrive PI 2 from US/WY	2	P	–	P	4	2	–	3	4	4	4	4	3	–

Platforms 4 and 5		
First Movement	Second Movement	Margin
Time between trains in the same direction in the same platform		4
Time between trains in the opposite direction in the same platform		5
Calling on restrictive aspect 3 mins between movements in same direction	Plus 1 running time for arrival	
Arrive Platform 4 from north	Arrive Platform 5 from south/Nene	3
Arrive Platform 5 from south/Nene	Arrive Platform 4 from north	3
Arrive 2-Way Goods lines from north	Arrive Platform 5 from south	3
Depart 2-Way Goods lines to north	Arrive Platform 5 from south	4
Arrive Platform 5 from south	Depart 2-Way Goods lines to north	Parallel
Arrive Platform 5 from south	Arrive/pass on the 2-Way Goods from the north	Parallel
Arrive Platform 4 from south	Depart 2-Way Goods to north/Down Main/West Yard	Parallel

Platforms 4 and 5 north end movements									
2 nd move → 1 st move ↓	Dep PI 4 to DSL	Dep PI 4 to DM/W Yd	Dep PI 5 to DSL	Dep PI 5 to DM/W Yd	Arr PI 4 from Up Stamford	Arr PI 5 from Up Stamford	Arr PI 4 from UM/US	Arr PI 5 from UM/US	Pass Down Main
Dep PI 4 to D Stamford	–	3	3	3	5	5	5	5	P
Dep PI 4 to DM/W Yd	3	–	P	3	5	P	6	6	7
Dep PI 5 to DS	3	P	–	3	P	5	P	5	P
Dep PI 5 to DM/W Yd	3	3	3	–	5	5	5	5	6
Arrive PI 4 from Up Stamford	–	–	P	1	–	4	4	4	P
Arrive PI 5 from Up Stamford	1	P	–	–	4	–	P	4	P
Arrive PI 4 from UM/USL	–	–	P	1	4	P	–	4	5
Arrive PI 5 from UM/USL	1	1	–	–	4	4	4	–	5
Pass Down Main	P	2	P	2	P	P	5	5	–
Arrive PI 2/3 from UM/US	P	P	P	P	P	P	3	3	P

Platform 4 and 5 south end movements											
2 nd move → 1 st move ↓	Dep PI 4 to Nene	Dep PI 5 to Nene	Dep PI 4 to March	Dep PI 5 to March	Dep PI 5 via 2 way	Arr PI 4 from DM/DS	Arr PI 5 from DM/DS	Arr PI 4 from Nene	Arr PI 5 from Nene	Arr PI 4 from March	Arr PI 5 from March
Dep PI 4 to Nene Sdgs	–	4	3	3	P	4	4	7	7	4	P
Dep PI 5 to Nene Sdgs	4	–	3	3	3	4	5	7	7	4	4
Dep PI 4 to March	3	3	–	3	A	4	4	3	3	4	P
Dep PI 5 to March	3	3	3	–	–	4	4	3	3	4	4
Dep PI 5 via 2 way	P	3	A	–	–	P	4	P	3	7	7
Arr PI 4 from DM/DS	–	1	–	1	P	–	4	3	3	3	P
Arr PI 5 from DM/DS	1	–	1	–	–	4	–	3	3	4	4
Arr PI 4 from Nene	–	1	–	1	P	4	4	–	4	4	P
Arr PI 5 from Nene	1	–	1	–	–	4	4	4	–	4	4
Arr PI 4 from March	–	1	–	1	1	4	4	4	3	–	4
Arr PI 5 from March	P	–	P	–	–	P	4	P	3	4	–

Peterborough continued		
Junction Margins		
North End Movements		
First Movement	Second Movement	Margin
Dep Pt 5 to Down Fast	Pass Plat 6 to Down Stamford /Up Slow	3½
Pass Pt 5 from Up Slow	Arrive Plat 1 from Up Slow	4
Pass Pt 5 from Up Slow	Pass Plat 3 from Up Fast	3
Pass Pt 5 from Up Slow	Arrive Plat 6 from Up Stamford	3½
Dep Pt 6 to Down Fast	Dep Platform 5 to Down Stamford/ Down Fast /Up Slow/	3
Dep Pt 6 to Down Fast	Arrive Platform 5 from Up Slow	4
Dep Pt 6 to Up Slow	Pass Platform 3 from Up Fast	3½
Dep Pt 6 to Up Slow	Pass Down Fast	4
Arrive Platform 5 from Down Fast/Down Slow	Arrive Platform 6 from Up Slow/Up Fast/Up Stamford	4
Arrive Platform 6 from Up Slow/Up Fast/Up Stamford	Arrive Platform 5 from Down Fast/Down Slow	4
Arrive Pt 6 from Up Slow	Arrive Platform 1/2 from Up Fast	3
Arrive Pt 6 from Up Slow	Arrive Platform 3 from Up Fast	3
Arrive Pt 6 from Up Slow	Pass Down Fast	2
Pass Pt 6 from Up Slow	Pass Platform 3 from Up Fast	3
Pass Pt 6 from Up Slow	Arrive Platform 4 from Up Fast/Stamford	3½
Train Watering Points		
	Platforms 1, 3 and Nene Sidings	
Turnround		
To/from Spalding	5	
To/from Lincoln	7	
To/from Doncaster, or North or West of Lincoln	10	
To/from East Anglia	10	
Suburban EMU services	Suburban EMU turnaround to be 6 minutes absolute minimum all day.	

New England North Junction		
Junction Margins		
First Movement	Second Movement	Margin
Down Freight to clear to Down Stamford line	Before Down train passes Peterborough (DFL)	3
Down Freight to clear to Down Stamford line	Before Up train passes Tallington (UFL)	2
Down Freight to clear to Down Stamford line	Before Up train passes Werrington Junction (USL)	2
Down Freight to clear to Down Stamford line	Before Up train passes Helpston (from Stamford)	1
Up Freight (from Ketton) to clear to Peterborough Yard – A/D lines	Before Down train passes Peterborough	3
Up Freight (from Ketton) to clear to Peterborough Yard – A/D lines	Before Up train passes Tallington	2

Werrington Junction		
Junction Margins		
First Movement	Second Movement	Margin
Pass to Sleaford	Up train passes Tallington	1½
Up train passes Tallington	Pass to Sleaford	6
Pass to Sleaford	Down train passes Peterborough	3
Pass to Sleaford	Down train departs Peterborough	1

Helpston Junction		
Junction Margins		
First Movement	Second Movement	Margin
Pass Down Slow to Tallington	Pass from Stamford	4
Pass from Stamford	Pass Down Slow to Tallington Junction	3

Tallington Junction		
Junction Margins		
First Movement	Second Movement	Margin
Train clear to SL	Next train pass Up/Down Main	4
Pass Up or Down Main	Pass from SL	3
Adjustments to Sectional Running Times		
Movement Down	Reason	Value
Approaching Tallington	DF-DS approach control and differential junction speed	2 HST/180/ 225
Movement Up	Reason	Value
Approaching Tallington	UF – US; approach control and differential junction speed	2 HST/180/ 225
After Tallington	US – UF; approach control and differential junction speed	2 HST/180/ 225

Stoke Junction		
Adjustments to Sectional Running Times		
Movement Down	Reason	Value
After Stoke Jn	DS – DF; differential junction speed	1 HST/180/ 225
Movement Up	Reason	Value
Approaching Stoke Jn * When UF from Grantham	UF – US*; approach control and differential junction speed	1 HST/180/ 225
Junction Margins		
First Movement	Second Movement	Margin
Pass DFL	Depart DSL	1½ ^{\$}
Pass DFL	Pass DSL to DFL	3

Stoke Junction		
Cross to Up Slow before next Up train passes		4
\$ maximum of (2) approaching Stoke on DSL permitted for trains following Down Fast. Otherwise * stop at Stoke Junction to be shown.		

Highdyke Junction		
Junction Margins		
First Movement	Second Movement	Margin
Up train passes Stoke Junction	Depart from Up Slow	½

Grantham		
Adjustments to Sectional Running Times (to be shown after this location)		
Movement	Reason	Value
Down Fast to P4/Up & Down Slow	Approach control and differential junction speed at Grantham South Jn	1½ HST/ 180/225
Stoke Jn to Nottingham Branch Jn to Allington triangle; pass to pass	Approach control and differential junction speed at Grantham South Jn	2 Freight
Up Fast only to Up Slow (to Highdyke Jn)	Approach control and differential junction speed	2 Freight
P4/Up & Down Slow to Up Fast	Differential junction speed at Grantham South Jn	2 HST/180/ 225
Allington triangle to Nottingham Branch Jn to Stoke Jn; pass to pass	Differential junction speed at Grantham South Jn	2 Freight
Connectional Allowance	7	
Dwell Time		
365	1	
DMU	2*. * 4 for reversing trains	
LH/HST	1½	
180	1½	
Minimum Turnround	7 – DMU/EMU	
Junction Margins		
In the following tables, 'P' denotes a parallel move.		
Time in-between trains in the same direction in the same platform – 4 mins		
First Movement	Second Movement	Margin
Arrive Platform 4 from Stoke	Depart Platform 3 to Nottingham Branch Junction	2
Arrive Platform 4 from Stoke	Arrive Platform 3 from Nottingham Branch Junction	4
Arrive Platform 3 from Nottingham Branch Junction	Arrive Platform 4 from Stoke	4
North End movements		

Grantham								
2 nd move → 1 st move ↓	Arr PI ¾ * from Claypole	Arr PI ¾ * from Nottm	Dep PI ¾ * to Claypole	Dep PI ¾ * to Nottm	Pass Down Main	Dep Down Main	Pass Up Main	Arr Up Main
Arr PI ¾ * from Claypole	–	4	2	2	3	1	3	4
Arr PI ¾ * from Nottm	4	–	2	2	P	P	P	P
Dep PI ¾ * to Claypole	8	7	–	4	7	6	P	P
Dep PI ¾ * to Nottm	7	7	4	–	P	P	P	P
Pass Down Main	6	P	2	P	–	–	P	P
Dep Down Main	7	P	3	P	–	–	P	P
Pass Up Main	7	P	P	P	P	P	–	–
Arr Up Main	6	P	P	P	P	P	–	–
* Platform ¾ margins also apply to movements to/from GL								
South End movements								
First Movement			Second Movement			Margin		
Up Train from Up/Down Slow depart Grantham			Down train passes/arrives Grantham			5		
Down train passes/arrives Grantham			Up Train from Up/Down Slow depart Grantham			2		
Up train passes			Up Train from Up/Down Slow depart Grantham			2		
Up train departs			Up Train from Up/Down Slow depart Grantham			3		

Claypole Loop
Restrictions
In Down directions, train in excess of 350 yards (50 SLU) in length are only permitted to stand for a maximum of 15 minutes

Newark North Gate		
Advertised Differential	Trains to Nottingham should be advertised to depart 2 minutes earlier	
Adjustments to Sectional Running Times		
Movement (to be shown after Newark)	Reason	Value
UDPL/P3 to Down Main when Down Main to Retford	Junction differential when joining the Main line	½ HST/180/225
Newark Crossing East Jn via P3/UDG to the Up Main; pass to pass	Junction differential when joining the Main line	2 Freight
Movement (to be shown approaching Newark)	Reason	Value
Up Main to P3/UDPL	Approach control and differential junction speed	½ HST/180/225
Down Main to Newark Crossing East Jn via P3/UDG; pass to pass	Approach control and differential junction speed	2 Freight
Connectional Allowance	7	
Dwell Time		

Newark North Gate		
DMU/EMU	1½*. * 4 for reversing trains	
LH/HST	1½	
Junction Margins		
First Movement	Second Movement	Margin
Up train pass	Down train arrives in Platform 3/GL	4
Up train depart Platform 3/GL	Down train arrives in Platform 3/GL	4½
Down train arrives in Platform 3/GL	Up train arrive	4
Down train arrives in Platform 3/GL	Up train depart	1
Down train arrives into loop	Down train passes Newark NG	5
Down train arrives into loop	Up train passes Newark NG	4
Down train passes Newark NG	Down train depart loop	1
Up Train arrive loop	Up train pass Newark NG	5
Up Train depart Newark NG	Up train depart loop	2½
Minimum Turnround		
	7 – DMU/EMU 20 – VTEC	
Platform Re-occupation		
In same direction	4	

Newark Flat Crossing						
Adjustment to Sectional Running Time (to be shown after this location)						
Movement Down		Reason			Value	
Newark Northgate to Retford start to pass		Not at linespeed by Newark Flat Crossing			1 Class 91/180 1½ HST	
Newark Northgate to Retford start to stop		Not at linespeed by Newark Flat Crossing			1 HST/180 1½ Class 91	
Junction Margins						
2 nd move → 1 st move ↓	Down ECML passing Newark Flat Crossing	Down ECML calling Newark NG passing Flat Crossing	Up ECML passing Newark Flat Crossing	Up ECML calling Newark NG passing Flat Crossing	Nottm – Lincoln pass	Lincoln – Nottm pass
Down ECML passing Newark Flat Crossing	–	–	–	–	2½	2
Down ECML calling Newark NG passing Flat Crossing	–	–	–	–	3	2½
Up ECML passing Newark Flat Crossing	–	–	–	–	3½	3
Up ECML calling Newark NG passing Flat Crossing	–	–	–	–	3	2½
Nottingham– Lincoln pass	4½	3½	4½	5	–	–
Lincoln– Nottingham pass	4½	4	4½	5	–	–

Carlton Loops		
Junction Margins		
First Movement	Second Movement	Margin
Down train arrive	Next Down pass Newark North Gate	1 before first train arrives Loop
Down train arrive	Next Down depart Newark North Gate	2½-before first train arrives Loop
Down train passes Newark North Gate	Depart Loop	5
Down train departs Newark North Gate	Depart Loop	7
Up train arrive	Next Up pass Retford	4½ before first train arrives Loop
Up train arrive	Next Up depart Retford	7 before first train arrives Loop
Up train passes Retford	Depart Loop	8½
Up train departs Retford	Depart Loop	11½

Retford High Level		
Adjustment to Sectional Running Time		
Movement	Reason	Value
Newark Flat Crossing/Carlton Loop to Retford to Thrumpton West Jn (not stopping at Retford)	Not at linespeed passing Retford	2 Approach Retford
Thrumpton West Jn to Retford to Newark Flat Crossing/Carlton Loop (not stopping at Retford)	Not at linespeed passing Retford	2 After Retford
Down freight trains to Babworth loop	Slow Speed Crossover	2 Approach Retford
Connectional Allowance	10	
Dwell Time		
HST/LH	1½	
Junction Margins		
First Movement	Second Movement	Margin
Arrive from Worksop and shunt to single line	Down train arrives	8
Arrive from Worksop and shunt to siding	Down train arrives	10
Depart to Worksop	Next train arrives from Worksop	7
Depart to Worksop	Down train arrives	5
Pass Up or Down	Depart Up or Down platform	2
Minimum Turnround	10 – DMU/EMU. ECS moves to Single Line, Down Slow or Siding may require extended turnrounds	

Babworth Loop		
Junction Margins		

Babworth Loop		
First Movement	Second Movement	Margin
Pass Down Main at Retford	Depart Down Loop	2

Ranskill Loop		
Junction Margins		
First Movement	Second Movement	Margin
Arrive Loop	Down train passes Retford	2
Arrive Loop	Down train departs Retford	1
Down train passes Retford	Depart Loop	5
Down train departs Retford	Depart Loop	7
Arrive Loop	Up train passes Loversall Carr	Same time
Up train passes Retford	Depart Loop	1
Up train arrives Retford	Depart Loop	2

Loversall Carr Junction		
Adjustments to Sectional Running Times		
Movements Down	Reason	Value
All Passenger trains to West Slow Line approaching Loversall Carr	Differential Speed	1
Movements Up	Reason	Value
All Passenger trains from Up East Slow Line approaching Retford	Acceleration	1
Junction Margins		
First Movement	Second Movement	Margin
Cross to Down SL	Next train passes	4½
Depart US to UF	After train passes	2
Pass US to UF	After train passes	3

Black Carr Junction		
Junction Margins		
First Movement	Second Movement	Margin
Pass to Loversall Carr Junction	Pass from Bessacarr Junction	3½

Decoy North Junction		
Junction Margins		
First Movement	Second Movement	Margin
Cross to WSL	Next train passes Loversall Carr	3
Down pass/arrive Doncaster	Pass DSL to FL	Same time

Doncaster		
Adjustments to Sectional Running Times		

Doncaster		
Movement Down	Reason	Value
Trains arriving Platform 5	TPWS	½
Movements Up		
Trains stopping or passing Doncaster if diverging from Up Fast Up to up East Slow. Up fast to Thorne Slow into platform 1 or Up Fast to Down side, approaching Doncaster.	Approach control	1 Passenger 2 Freight
Trains from Up Leeds line if diverging to Down Side. Approaching Doncaster	Approach control	1 (Except DMU/EMUs)
Trains from Up Leeds line if diverging to Up East Slow line. Approaching Doncaster	Approach control	2
Trains arriving Platforms 6 and 7	TPWS	½
Connectional Allowance		
	7	
Dwell Time		
DMU	2	
HST/LH	2	
XC 22x	2 (Can be 1½ if no transfer of catering trolleys)	
TPE	2	
Junction Margins		
South End Movements		
First Movement	Second Movement	Margin
Depart Platform 1 to South	Arrive from Carrage Sidings to depart 1 to North	
Arrive Platform 3B from Down	Pass Up/Down Main	3½
Depart Plat 3B to Sheffield/WSL	Pass Up/Down Main	4
Depart Plat 3B to Sheffield/WSL	Arrive from Down Main/Slow	5
Depart Plats 3B/4/5/8 to Sheffield	Arrive Platforms 3B/4/5 from Sheffield	6
Arrive Plats 3B/4/5 from Sheffield	Depart Platforms 3B/4/5/8 to Sheffield	2
Arrive Platform 8 from Sheffield	Depart Platforms 3B/4/5 to Sheffield	Parallel
Pass Up/Down Main	Depart Platform 3B to Sheffield	1
Pass Up/Down Main	Arrive Platform 3B from Sheffield/WSL	3½
Arrive Platform 4/5 from Sheffield	Arrive Platform 8 from Down Main/Slow	4
Arrive Plat 4/8 from Down Main/Slow	Arrive Platform 3 from Sheffield	3
Depart Platform 4/5 to Sheffield	Arrive Platforms 4, 5, 8 from Down M/S	4
Arrive Plat 3B from Sheffield	Arrive Platforms 4, 5, 8 from Down M/S	3½
Arrive Plats 4, 5, 8 from Sheffield/SL	Depart Goods Lines	2
Arrive Platform 2	Depart Platform 1	1
Arrive Platform 2	Pass Platform 1	4
Arrive Platform 2	Depart Platform 3 to ESL	1
Arrive Platform 2	Pass Platform 3	4
Arrive Platform 2 via ESL 2401pts	Depart Platform 3 to UF	Parallel
Depart Platform 1 to UF	Depart Platform 2 to ESL	2½
Depart Platform 2 to ESL	Depart Platform 1 to UF	2
North End Movements		
First Movement	Second Movement	Margin
Depart Plat 0 to Up Thorne	Arrive Plat 0 from Down Thorne	4
Depart Plat 0 to Up Thorne	Arrive Plat 1 from York (via Thorne Slow)	4½
Arrive Plat 1 from York (via Thorne Slow)	Arrive Plat 0 from Down Thorne	2½

Doncaster		
Arrive Plat 0 from Down Thorne	Arrive Plat 1 from York (via Thorne Slow)	3
Dept Plat 0 to Up Thorne	Arrive Plat 3 from York	4 (parallel unless arrival is via Up ESL)
Dept Plat 0 to Up Thorne	Arrive Plat 1 from Down Thorne	4
Arrive Platforms 1/3 from Leeds	Depart to York/Thorne	1
Pass Down Main (to York)	Pass Up Main (from Leeds)	3½
Pass Down Main (to York)	Arrive Plat 1/3 (from Leeds)	4
Depart Down Main (to York)	Pass Up Main (from Leeds)	4
Depart Down Main (to York)	Arrive Plat 1/3 (from Leeds)	5
Depart Plat 4 to Leeds/York	Depart Plat 8 to Thorne	2
Pass Up Main (from York)	Arrive Up Main (from Leeds)	4
Pass Plat 1/3 from East Slow	Arrive Plat 1/3 from York/Leeds	5
Depart Plat 8 to Thorne	Depart Plat 4 to Leeds or York	2
Depart Plats 4, 6, 7, 8 to Thorne	Arrive from Leeds or York	4½
Depart Plats 4, 6, 7, 8 to Thorne	Pass from Leeds or York	4
Depart Goods Lines to Thorne	Depart Plat 4 to Leeds or York	4
Arrive/Depart Plats 4, 6, 7, 8 from Thorne	Pass Up Main/Down Main	4
Arrive Plats 4, 6, 7, 8 from Thorne	Arrive Plats 1/3	3½
Arrive Plat 1 from Leeds/York	Arrive Plat 3B from Thorne	2
Arrive Plat 1/3 from Leeds/York	Arrive Plats 4, 6, 7, 8 from Thorne	4
Arrive Plat 3B from South	Arrive Plat 1 from Leeds	6*
Arrive Plat 1 from Leeds/York	Arrive Plat 3B from South	4*
Pass Up Main/Down Main	Arrive Plats 4, 6, 7, 8 from Thorne/York	4
Pass Up Main/Down Main	Depart to Thorne from Down Side	1
Arrive Plat 1 from Leeds	Arrive Plat 3 from York	4
Depart Plats 4, 6, 7, 8 to York	Pass Down Main (to Leeds)	4½
Depart Plat 3B to Leeds/York	Arrive Plat 3B from Leeds/York	5
Depart Plats 4, 6, 7, 8 to North	Arrive Plats 4, 6, 7, 8 from North	5 when conflicting
Depart Plats 1/3 to Thorne	Arrive Plats 1/3 from Thorne	3
Arrive Plats 6, 7 from North	Follow to same platforms	3
Arrive Plats 4, 8 from North	Follow to same platforms	3½
Arrive Plats 4, 6, 7, 8 from North	Dep Goods Lines	2
* refers to Overlap Restrictions		
Minimum Turnround	7 – Leeds EMU services, but not 2 consecutive	
	10 – DMU/EMU from Leeds, Sheffield, Humberside area, Lincolnshire and Peterborough. Any reduction must be specially agreed	
Operating Restrictions –		
Doncaster Station. Trains from the Sheffield direction arriving into Platform 3B will hold the overlap so trains cannot arrive into Platform 1 from the Up Main line/Leeds Line. Trains from the Shaftholme Junction direction can access Platform 1 simultaneously by using the Down Thorne Slow line which will add an extra 1 minute running time. This should be shown in the timetable as Adjustment allowance.		
Doncaster West Yard. Electrically hauled trains shunting to or from Doncaster West Yard must be routed to stand behind Signal D1488 or on to the Thorne Lines due to the presence of an OHL Neutral Section		
Platform Re-occupation		
In same direction	4 (3 DMU)	
In opposite direction	5 (4 DMU)	
Train Watering Points	Platforms 2, 5, 6, 7, Middle Road	

Arksey Loop		
Junction Margins		
First Movement	Second Movement	Margin
Arrive in Loop	Before Down train passes Doncaster	3
Arrive in Loop	Before Down train departs Doncaster	1
Down Main pass Shaftholme Junction	Depart Down Loop	Same time

LN105 MOORGATE TO FINSBURY PARK JUNCTION		
Moorgate		
Junction Margins and Platform Re-occupations – Crossing via Throat		
First Movement	Second Movement	Margin
Arrive Platform 9	Depart Platform 10	1
Depart Platform 9	Arrive Platform 9	2½
Depart Platform 9	Arrive Platform 10	Parallel
Arrive Platform 10	Depart Platform 9	Parallel
Depart Platform 10	Arrive Platform 9	2½
Depart Platform 10	Arrive Platform 10	2½
Station Working		
ARS will automatically route trains into platform 9 if it is not occupied		

Highbury & Islington	
Dwell Time	
EMU	1

LN110 CANONBURY WEST JUNCTION TO FINSBURY PARK JUNCTION		
Highbury Vale Junction		
Junction Margins		
First Movement	Second Movement	Margin
Train from Canonbury West Junction	Train to Canonbury West Junction	2½

LN115 COPENHAGEN JUNCTION TO CAMDEN ROAD CENTRAL JUNCTION		
York Way North Junction		
Junction Margins		
Movement		Margin
Fouling Move		2½
Where trains are required to stand at Copenhagen Junction and are likely to be in excess of 620 metres in length then these should be held at York Way North Junction		

Camden Road Central Junction		
Junction Margins		
		Margin
Up Trains towards Camden Road on the North London Line	Down Train towards Copenhagen Junction on the North London Incline Line	3
Down Train travelling towards Copenhagen Junction on the North London Incline Line	Up Train travelling towards Camden Road on the North London Line	3

LN120 WOOD GREEN NORTH JUNCTION TO LANGLEY JUNCTION (VIA HERTFORD)		
Bowes Park		
Junction Margins		
First Movement	Second Movement	Margin
Arrive Reversing Siding	Next train depart/pass Alexandra Palace	1
Arrive/pass Alexandra Palace	Depart Reversing Siding	Same time
Depart Reversing Siding	Fast passes Gordon Hill	Same time
Depart Reversing Siding	All stations departs Winchmore Hill	Same time
Depart Reversing Siding	Semi Fast departs Winchmore Hill	1

Palmers Green	
Dwell Time	
	1 Up peak Trains arriving King's Cross/Moorgate 0700 – 0959 SX
	1 Down peak Trains departing King's Cross/Moorgate 1600 – 1859 SX

Winchmore Hill	
Dwell Time	
	1 Up peak Trains arriving King's Cross/Moorgate 0700 – 0959 SX
	1 Down peak Trains departing King's Cross/Moorgate 1600 – 1859 SX

Enfield Chase	
Dwell Time	
	1 Up peak Trains arriving King's Cross/Moorgate 0700 – 0959 SX
	1 Down peak Trains departing King's Cross/Moorgate 1600 – 1859 SX Trains terminating at Gordon Hill may have a ½ minute dwell time by agreement with the Train Operator if deemed appropriate

Gordon Hill		
Junction Margins		
First Movement	Second Movement	Margin
Arrive Up Bay	Arrive /Pass Up Platform	3
Arrive Up Bay	Depart Up Platform	1
Arrive Up Main	Depart Up Bay	1
Depart Up Bay	Arrive/Pass Up Platforms	3
Depart / Pass Up Main	Arrive Up Bay	3
Pass Up Main	Depart Up Bay	2
Adjustments to Sectional Running Times		
Movement Down	Reason	Value
Trains arriving Up Bay	Approach Control	½
Dwell Time		
	1 Up peak Trains arriving King's Cross/Moorgate 0700 – 0959 SX	
	1 Down peak Trains departing King's Cross/Moorgate 1600 – 1859 SX	

Hertford North		
Dwell Time		
EMU	1 Up peak Trains arriving King's Cross/Moorgate 0700 – 0959 SX	
	1 Down peak Trains departing King's Cross/Moorgate 1600 – 1859 SX	
Adjustments to Sectional Running Times		
Movement Down	Reason	Value
Trains Arriving Down Bay	Approach Control	½
Junction Margins		
First Movement	Second Movement	Margin
Pass Platform 1	Depart Platform 3	3
Depart / Pass Platform 1	Arrive Platform 1 from Down Hertford	4
Arrive Platform 3	Arrive/Pass Platform 2 from Down Hertford Northbound	4
Arrive Platform 3	Depart Platform 2 to Up Hertford	1
Arrive Platform 2	Depart Platform 3	1
Depart Platform 2 to Up Hertford Southbound	Arrive Platform 3	4
Depart Platform 3	Arrive / Pass Platform 2 from Down Hertford Northbound	3½
Depart Platform 3	Arrive Platform 1 from the South	4
Depart to Up Hertford not calling Bayford	Depart to Up Hertford calling Bayford	4
Depart to Up Hertford Southbound	Depart to Up Carriage Sidings	3
Arrive platform 1 from Down Hertford	Depart platform 2 to Up Hertford Southbound	1
Arrive platform 1 from Down Hertford	Depart platform 3 to Up Hertford	1
Depart platform 2 to Up Hertford Southbound	Pass / arrive platform 2 from Down Hertford Northbound	3
Depart platform 2 to Up Hertford Southbound	Arrive platform 1 from Down Hertford	4
Hertford North Up Sidings Capability No 1 Sidings 12 Cars but not currently in use due to lack of suitable lighting and walkways No 2 Sidings 6 Cars No 3 Sidings 6 Cars No 4 Sidings 3 Cars		

Molewood Junction		
First Movement	Second Movement	Margin
Up Train Pass	Passenger Train Pass	3
Up Train Pass	Freight Train Pass	3½

Bragbury Junction		
First Movement	Second Movement	Margin
Down Train Pass	Up Passenger Train Pass	2½
Down Train Pass	Up Freight Train Pass	3

Langley South Junction		
Junction Margins		
First Movement	Second Movement	Margin
Pass Down to Up	Down train departs Watton	Same time
Pass Down to Up	Before next fast train from Branch passes Langley Junction	5

LN125 HITCHIN CAMBRIDGE JUNCTION TO ROYSTON (INCLUSIVE)		
Letchworth Garden City		
Dwell Time		
EMU	1	
Station Working		
Down terminating trains require a minimum dwell of 2 minutes before departing ECS		
Junction Margins		
First Movement	Second Movement	Margin
Arrive/pass from A/D line	Arrive Down platform	3½
Depart/pass from C S reception	Arrive/pass to C S reception from Up direction	3
Pass/Depart Up Platform	Arrive from A/D line	3
Platform Re-occupation		
Platform Re-occupation in the same direction 3 minutes		
Turnrounds		
	All shunt movements to be timed	

Letchworth Garden City EMU Sidings	
Operating Stop / Operating Restrictions	<p>All services travelling from Letchworth A/D line to Letchworth CS Reception must be shown to have a 'dot stop' at Letchworth A/D line.</p> <p>All services travelling to/from Letchworth A/D line or Letchworth CS Reception towards or from Baldock direction must be shown to have a 'dot stop' at Letchworth CS Reception.</p> <p>All movements between Stop Board 4 and Letchworth Reception CS/Letchworth CSD and also Stop Board 5 and Letchworth A/D line/Letchworth CSD are controlled by the shunter and in most cases only one movement at any one time is permitted.</p> <p>Trains can be held at Stop Board 5 awaiting authority from the shunter to</p>

Letchworth Garden City EMU Sidings

	<p>proceed towards Letchworth CS Reception; however trains cannot be signaled from K954 signal (from Royston) to Stop Board 4 until the previous movement within the yard has arrived at Letchworth CSD or Letchworth A/D line.</p> <p>Trains of more than 8 cars should not be planned to stable in Letchworth CSD without prior agreement as trains longer than this will block the walkways.</p>
--	---

Junction Margins

First Movement	Second Movement	Margin
Pass/Depart Letchworth Garden City towards Royston	Depart Letchworth CS Reception towards Royston	3
Pass/Depart Letchworth Garden City towards Royston	Arrive Letchworth CS Reception	3
Arrive Letchworth CS Reception from Royston	Arrive/Pass Letchworth Garden City from Royston	5
Arrive Letchworth CS Reception from Royston	Depart Letchworth Garden City towards Royston	1
Arrive Letchworth CS Reception from Royston	Pass Letchworth Garden City towards Royston	3
Depart Letchworth CSD towards Royston	Depart Letchworth CSD towards Royston or Letchworth A/D line	10
Depart Letchworth CSD towards A/D line	Depart Letchworth CSD towards Royston or Letchworth A/D line	23 (if first train formed of up to 6 cars) 24 (if first train formed of 8 cars)
Arrive Letchworth CSD from Royston	Arrive Letchworth CSD from Royston	10
Arrive Letchworth CSD from Letchworth A/D	Depart Letchworth A/D towards Letchworth CS Reception	Same Time
Arrive Letchworth CSD from Letchworth A/D	Arrive at Letchworth CS Reception from Royston	6

Baldock

Dwell Time

EMU	1 Up peak trains arriving St Pancras Low Level / King's Cross / Moorgate between 0700 –0959 SX which run non-stop between Hitchin or Stevenage and Finsbury Park
------------	--

Junction Margins

First Movement	Second Movement	Margin
Depart Up platform	Arrive up platform from Down	3½
Up fast pass Letchworth	Arrive up platform from Down	½
Up fast arrive Letchworth	Arrive up platform from Down	same time

Royston		
Dwell Time		
EMU	1	
Junction Margins		
First Movement	Second Movement	Margin
All crossing margins at south end		3½
All crossing margins at north end		4
Arrive Platform 2 from Cambridge	Depart Platform 1 to Cambridge	1
Arrive Platform 1 from Letchworth Garden City	Depart Platform 2 to Letchworth Garden City	1
Pass/Depart Up not calling at Ashwell	Depart Up calling at Ashwell	3
Platform Re-occupation in the same direction 3 minutes		
Adjustments to Sectional Running Times		
Movement Up	Reason	Value
Shepreth Branch Junction to Royston	Arrive from Up Cambridge into platform 2 or attaching to unit already in platform 1; approach control	½
Movement Down	Reason	Value
Royston to Shepreth Branch Junction	Platform 1 to Down Cambridge; differential junction speed	½
Minimum Turnround	6 minutes for Suburban EMU services	

LN150 FLYOVER EAST JUNCTION TO DECOY NORTH JUNCTION		
Decoy South Junction		
Junction Margins		
First Movement	Second Movement	Margin
Pass from St Catherines Junction	Re-occupy single line	3

Bridge Junction		
Junction Margins		
First Movement	Second Movement	Margin
Train to Hexthorpe Junction	Train to Belmont Yard	3
Train to Belmont Yard	Train to Doncaster from WSL	3½

LN170 WERRINGTON JUNCTION TO FLYOVER EAST JUNCTION (VIA LINCOLN)		
Spalding		
Dwell Time		
EMU-DMU	1	
Minimum Turnround		
4 trains from Peterborough		
Junction Margins		
First Movement	Second Movement	Margin
Up Train Pass/Depart Platform 1	Down Train terminates Platform 1	3

Sleaford South Junction		
Junction Margins		
First Movement	Second Movement	Margin
Up train passes from Sleaford	Down fast pass	2 ½
Down fast pass	Up train passes from Sleaford	2
Up train passes from Sleaford	Down train passes to Sleaford	2 ½

Sleaford North Junction		
Junction Margins		
First Movement	Second Movement	Margin
Up train passes to Sleaford	Down fast pass	2
Down fast pass	Up train passes to Sleaford	3
Down train passes from Sleaford	Up train passes to Sleaford	3

Pelham Street Junction		
Junction Margins		
First Movement	Second Movement	Margin
Pass from Market Rasen	Pass to Sleaford	3
Pass to Sleaford	Pass from Market Rasen	4

Lincoln		
Attachment of Locomotives/Units		
Attach DMU	3	
Dwell Time		
All	2	
Junction Margins		
First Movement	Second Movement	Margin
Terminating train arrive from North or East arrive	Terminating train from North or East arrive	7
Arrive from Market Rasen	Arrive from Metheringham	5
Minimum Turnround	12 trains from Sheffield, Nottingham, Cleethorpes or Peterborough	
	15 trains from beyond Sheffield, Nottingham or Peterborough	
Where minimum turnrounds have been increased and shorter turnrounds already apply for some trains in the 2000 timetable, existing values may continue to be used for a similar number of trains, provided they are not further reduced. In the event that the service is amended by changes to the overall pattern, the new values will apply.		

West Holmes Junction		
Junction Margins		
First Movement	Second Movement	Margin
Pass to Gainsborough	Pass from Newark	3½
Pass from Newark	Pass to Gainsborough	3

Pyewipe Junction		
Junction Margins		
First Movement	Second Movement	Margin
Pass West Holmes Junction to Gainsborough	Pass to Boultham Junction	5
Pass to Boultham Junction	Pass West Holmes Junction to Gainsborough	3
Pass from Boultham Junction	Pass to Boultham Junction	4

Gainsborough Lea Road	
Dwell Time	
All	1

Bessacarr Junction		
Adjustment to sectional running time		
Movement Down	Reason	Value
Approaching Bessacarr Junction – for trains to Black Carr Junction or Up Lincoln Flyover	Approach Control	1½ Freight ½ Passenger
Junction Margins		
First Movement	Second Movement	Margin
All conflicting moves		3

LN185 ALLINGTON WEST JUNCTION TO SKEGNESS		
Allington West Junction		
Junction Margins		
First Movement	Second Movement	Margin
Pass from Nottingham towards Grantham	Pass from Sleaford	4
Pass from Sleaford	Pass to Grantham	4

Allington North Junction		
Junction Margins		
First Movement	Second Movement	Margin
Pass from Sleaford towards Allington West Junction	Pass from Allington East towards Sleaford	3½
Pass from Allington East towards Sleaford	Pass from Sleaford towards Allington West Junction	2½

Sleaford		
Dwell Time		
All		1
Junction Margins		
First Movement	Second Movement	Margin
Down train from Lincoln or Grantham arrive Platform 1	Up train from Spalding or Skegness arrive Platform 2	3
Up train from Spalding or Skegness arrive Platform 2	Down train from Lincoln or Grantham arrive Platform 1	2
Down train from Lincoln or Grantham arrive Platform 3	Up train from Spalding or Skegness arrive Platform 2	4
Up train from Spalding or Skegness arrive Platform 2	Down train from Lincoln or Grantham arrive Platform 3	4
Up train departs to Lincoln from Platform 3	Down train from Grantham arrive	6
Down train from Lincoln or Grantham arrive	Up train departs to Lincoln from Platform 3	1
Up train departs to Lincoln or Grantham from Platform 3	Up train from Spalding or Skegness arrive	4
Train arrives from Grantham	Train from Lincoln pass Sleaford N Junction	2
Train from Lincoln arrives Platform 3	Train from Grantham arrive	6
Arrive from Spalding or Skegness	Depart to Spalding or Skegness	1
Arrive from Lincoln	Depart to Lincoln	2
Depart to Spalding	Arrive from Skegness	6
Depart to Skegness	Arrive from Spalding	7
Minimum Turnround		
	5 trains from Peterborough, Lincoln or Grantham	
	10 trains from beyond Peterborough, Lincoln or Grantham	

Heckington		
Adjustment to sectional running time		
Movement Down	Reason	Value
Departing Heckington	Only applies to trains consisting of 5 or more vehicles. HN13 signal which protects Great Hale Drove LC on the Down line, will not clear until the train clears the track circuit in rear.	3
Junction Margins		
First Movement	Second Movement	Margin
Train from Sleaford	Train to Sleaford	3
Restriction. No acceptance into Up platform until 2 minutes after train has arrived off the Single Line from Sleaford.		

Hubberts Bridge		
Junction Margins		
First Movement	Second Movement	Margin
Train from Boston	Train to Boston	3
Restriction. No acceptance into Down platform until 2 minutes after train has arrived off Single Line from Boston		

Boston		
Adjustments to Sectional Running Times		
Movement Down	Reason	Value
Trains bound for Boston Docks. Approaching Boston Station	To cover the time required for: a) the train to stop adjacent Sleaford Siding G.F. and collect a radio from the shunter; b) the train to draw forward towards Boston station	3
Dwell Time		
All		1
Junction Margins		
First Movement	Second Movement	Margin
Arrive from Hubberts Bridge	Depart to Hubberts Bridge	Same time
Arrive from Skegness	Depart to Skegness	2
Minimum Turnround		
		8

Sibsey		
Junction Margins		
First Movement	Second Movement	Margin
Train from Boston	Train to Boston	3

Skegness		
Minimum Turnround		
	7 trains from Nottingham	
	15 trains from beyond Nottingham	
Where minimum turnrounds have been increased and shorter turnrounds already apply for some trains in the 2000 timetable, existing values may continue to be used for a similar number of trains, provided they are not further reduced. In the event that the service is amended by changes to the overall pattern, the new values will apply		
Platforming	Due to the lack of platform lighting, only Platforms 3 and 4 should be used during the hours of darkness.	

LN190 ALLINGTON EAST JUNCTION TO ALLINGTON NORTH JUNCTION (ALLINGTON CHORD)		
Allington East Junction		
Junction Margins		
First Movement	Second Movement	Margin
Pass from Nottingham towards Grantham	Pass towards Allington North	3
Pass towards Allington North	Pass from Nottingham towards Grantham	2½

Allington North Junction		
Junction Margins		
First Movement	Second Movement	Margin
Pass from Sleaford towards Allington West Junction	Pass from Allington East towards Sleaford	3½
Pass from Allington East towards Sleaford	Pass from Sleaford towards Allington West Junction	2½

LN206 NEWARK FLAT CROSSING (INCLUSIVE) TO WEST HOLMES JUNCTION		
Newark Flat Crossing		
Junction Margins		
First Movement	Second Movement	Margin
Lincoln – Nottingham pass	Down train pass ECML	4½
Lincoln – Nottingham pass	Down train calling Newark North Gate pass ECML	4
Down train pass Newark Flat Crossing	Lincoln – Nottingham pass	2
Down train stopping Newark North Gate	Lincoln – Nottingham pass	2½
Lincoln – Nottingham pass	Up train pass ECML	4½
Lincoln – Nottingham pass	Up train calling Newark North Gate pass ECML	5
Up train pass ECML	Lincoln – Nottingham pass	3
Up train stopping Newark North Gate pass ECML	Lincoln – Nottingham pass	2½
Nottingham – Lincoln pass	Down train pass ECML	4½
Nottingham – Lincoln pass	Down train stopping Newark Nth Gate pass ECML	3½
Down train pass ECML	Nottingham – Lincoln pass	2½
Down train stopping Newark Nth Gate pass ECML	Nottingham – Lincoln pass	3
Nottingham – Lincoln pass	Up train pass ECML	4½
Nottingham – Lincoln pass	Up train stopping Newark North Gate pass ECML	5
Up train pass ECML	Nottingham – Lincoln pass	3½
Up train stopping Newark North Gate pass ECML	Nottingham – Lincoln pass	3

Newark Flat Crossing East Junction		
Adjustments to Sectional Running Times		
Movement Down	Reason	Value
Approaching Newark Flat Crossing East Junction – for trains to Newark North Gate	Slow speed junction	½ Class 15X only

Newark Flat Crossing East Junction		
Movement Up	Reason	Value
After Newark Flat Crossing East Junction– for trains from Newark North Gate	Slow speed junction	½ Class 15X only
Junction Margins		
First Movement	Second Movement	Margin
Pass from Nottingham	Arrive from Newark North Gate	4
Arrive/pass from Newark North Gate	Pass to Nottingham or Newark North Gate	4
Pass to Nottingham	Arrive from Newark North Gate	4
Pass to Nottingham	Depart to Newark North Gate	3
Depart to Newark North Gate	Pass to Nottingham	5
Depart to Newark North Gate	Pass from Nottingham	5
Depart to Nottingham (after reversal)	Pass/arrive from Nottingham	5
Minimum Reversal		
	3½	

Boultham Junction		
Junction Margins		
First Movement	Second Movement	Margin
Pass to Lincoln	Pass from Pyewipe Junction	3
Pass from Pyewipe Junction	Pass to Lincoln	4
Pass from Pyewipe Junction	Pass to Pyewipe Junction	4

LN220 BESSACARR JUNCTION TO BLACK CARR JUNCTION		
Bessacarr Junction		
Refer to LN170		

LN600 SHAFTHOLME JUNCTION TO RESTON GSP		
Shaftholme Junction		
Adjustments to Sectional Running Times		
Movement Up		
Pass from Knottingley. Approaching Doncaster	Differential junction speed	1 Freight 1½ Passenger
Movement Down		
Pass from Doncaster Platform 8	Slow Access to Down Main Line	1 Cross Country 22X
Junction Margins		
First Movement	Second Movement	Margin
Up train from Branch	Pass Down Main	5
Down train pass to Branch	Before next fast train	4
Up train from Branch	Down train to Branch	5
Down train pass to Temple Hirst	Up train pass from Branch	4
Down train pass to Temple Hirst	Up train start from Branch	1
Up train pass from Temple Hirst	Up train pass from Branch	4
Up train pass from Temple Hirst	Up train start from Branch	2

Joan Croft Junction		
Junction Margins		
First Movement	Second Movement	Margin
Down train from Branch	Up train passes Shaftholme Junction	5
Up train passes Shaftholme Junction	Down train from Branch	2
Down train passes Shaftholme Junction	Down train from Branch	3
Up train pass to Branch	Up train passes Temple Hirst Junction	Same time

Temple Hirst Junction		
Adjustments to Sectional Running Times		
Movement Up	Reason	Value
Pass from Selby. Approaching Shaftholme Junction	Differential junction speed	1 HST/170/180
Pass from Hambleton South Junction Approaching Shaftholme Junction	Differential Junction Speed	-½ 180/222
Junction Margins		
First Movement	Second Movement	Margin
Down Passenger pass to Branch	Before next Up/Down train	4
Down Freight pass to Branch	Before next Up/Down train	5
Pass Up Main	Pass to Branch	4
Down Passenger to Branch	Up Passenger/Freight from Branch	5
Down Freight to Branch	Up Passenger/Freight from Branch	6
Up Passenger from Branch	Down Passenger/Freight to Branch	5
Up Freight from Branch	Down Passenger/Freight to Branch	6

Hambleton South Junction		
Adjustments to Sectional Running Times		
Movement Down	Reason	Value
Pass to Hambleton West, if stopping at Hambleton West.	Approach control	1
Junction Margins		
First Movement	Second Movement	Margin
Down ML train pass Hambleton North Junction	Pass Hambleton South Junction from Hambleton West Junction	4*
Pass Hambleton South Junction to Hambleton West Junction	Down ML pass Hambleton North Junction	4
Pass Hambleton South Junction from Hambleton West Junction	Down ML train pass Hambleton North Junction	4
Up ML train passes Hambleton North Junction	Pass Hambleton South Junction from Hambleton West Junction	5 ^{\$}
* 1 minute if second train stopped at Hambleton South Junction		
\$ 2 if second train stopped at Hambleton South Junction		

Hambleton North Junction		
Junction Margins		
First Movement	Second Movement	Margin
Pass from Branch	Pass Up Main	4
Pass Up Main	Pass from Branch	3
Pass Up Main	Depart from Branch	1
Pass Down Main	Depart from Branch	2
Pass Down Main	Pass from Branch	3

Colton Junction		
Junction Margins		
First Movement	Second Movement	Margin
Pass NNL to Church Fenton	Pass from Hambleton	4
Pass from Hambleton	Pass NNL to Church Fenton	4

Colton North Junction		
Junction Margins		
First Movement	Second Movement	Margin
Up LSL pass Colton Junction	Down crossing movement pass Colton Junction	3
Down crossing movement pass Colton Junction	Up LSL pass Colton Junction	5
Up crossing movement pass Colton Junction	Down ML/NNL pass Colton Junction	3
Down ML/NNL pass Colton Junction	Up crossing movement pass Colton Junction	5

Holgate Sidings		
Junction Margins		
First Movement	Second Movement	Margin
Depart Holgate Sidings to Colton Junction	Arrive/pass York/York Yard South LSL	6
Arrive/pass York/York Yard South LSL	Depart Holgate Sidings to Colton Junction	1
Arrive Holgate Sidings from York/York Yard South	Arrive/pass York/York Yard South LSL	5
Arrive/Pass York/York Yard South	Arrive Holgate Sidings from York/York Yard South	3

Holgate Junction		
Junction Margins		
First Movement	Second Movement	Margin
Down pass/arrive York Yard South Junction	Arrive York from Leeds lines	4
Arrive York from Leeds lines	Up pass York Yard South Junction	3
Arrive York from Leeds lines	Up depart York Yard South Junction	Same time
Depart York on Leeds lines	Depart/pass York Yard South Junction	4
Up depart/pass York Yard South Junction	Arrive York from Leeds lines	5

York				
Adjustments to Sectional Running Times				
Movement	Reason			Value
Bay Platforms	TPWS			½
Approaching Platforms 11x from the south	Approach control			1
Up trains departing platform 4 (to be input at next timing point)	Additional distance through York station			½
Connectional Allowance				
	8			
Dwell Time				
DMU	3			
HST/LH	3			
XC Services (HST & 22x)	2			
TPE	2			
Grand Central	2			
Minimum Turnround				
	HST EWD	LH EWD	HST Sun	LH Sun
To/from London King's Cross	25	25	25	25
XC	20 (10 by exception and in agreement with Network Rail)			
TPE	8			
DMU/EMU	10 from Leeds, Sheffield, Newcastle, Middlesbrough, Scarborough, Hull, Harrogate and Manchester Victoria			
	15 from Blackpool which may be reduced to a minimum of 10 minutes by the number of minutes additional station dwell at Leeds of the incoming service			
Junction Margins outside 'Leaf Fall Period'				
First Movement	Second Movement			Margin
Trains following same direction				3
Arrive	Depart conflicting move			1
Between first departing and second arriving	South end and Scarborough line (or as below)			5
Between first departing and second arriving	North end			4
Junction Margins during 'Leaf Fall Period'				
First Movement	Second Movement			Margin
Arrive from Scarborough	Depart to Scarborough			1
Depart to Scarborough	Arrive from Scarborough			8
Note: Trains from Scarborough are not permitted to pass S4 signal at Haxby Road until the Down train has cleared the Single Line. No trains are to be planned into Platform 5 during this period.				
Junction Margins – Alternative Rules				
ARS coding now means the following alternative rules can apply for platform 11. By using the suffix 'x' to the platform number, ARS will always use the short overlap for that train, this results in the train being cautioned upon approach to York.				
First Movement	Second Movement			Margin
Arrive Platform 11x from Down Leeds	Arrive Platform 10 from Down Main			No conflict
Arrive Platform 11x from South	Arrive/Depart platform 10 from the North			No conflict
Platform 11x is not available from the North or from the down Main due to there being no short overlap.				
Overlap restrictions				
The following moves have an extended overlap which clears approximately ½ minute after arriving. The overlap must be clear for a minimum of 3 mins before the train arrives and 3 minutes after arrival must elapse before it is reoccupied by an arriving train, 1 minute for a departing train.				

York	
Movement	Conflict
Arrive/Depart Platform 2 from East	Arrive Platform 4 from South
Arrive Platform 3 from North/East	Arrive/depart Platform 1
Arrive Platform 3 from North/South	Arrive Platform 4 from East
Arrive Platform 4 from East	Arrive Platform 3 from North/South
Arrive Platform 10 from North	Arrive Platform 11 from Down Main
Arrive Platform 10 from North	Depart Platform 11 to the South*
Arrive Platform 11 from South	Arrive or Depart platform 10 to/from North
Arrive Platform 5 from South	Arrive/depart Platform 4 to/from East and Platform 8 to/from North when the routes are set at the same time
Arrive Platform 5 from South	Arrive Platform 3 from North and depart Platform 8 to North at the same time
*It is possible to depart Platform 11 to Holgate Sidings (only) the same time as an arrival from the north in Platform 10.	
The parallel move of arriving Platform 5/8 from the North at the same time as departing Platform 9/10/11/to North can be timetabled using the line code AL on the departing services.	
Platform Re-occupation	
In same direction	4
In opposite directions	5
Preferred Platform Usage	
To protect performance VTEC trains should where possible use the following platforms:	
VTEC xx:01-xx:03 York – King’s Cross services	Use platform 6
Southbound xx:53-xx:55 arrivals connecting into them	to use platform 5
Train Watering Points	Restricted use in Platforms 1, 2 and siding. Platforms 9 and 10

Skelton Junction		
Junction Margins		
First Movement	Second Movement	Margin
Pass towards Harrogate/Down Slow	Pass Down Fast/Slow	3
Pass to Harrogate	Pass from Harrogate	4
Pass from Harrogate	Pass to Harrogate	3½
Pass from Harrogate	Pass Down Fast/Slow	3½
Pass Down Fast/Slow	Pass from Harrogate	3
Pass Up Slow	Pass from Harrogate	3
Pass Up Fast	Pass from Harrogate	2½
Pass to/from Harrogate	Next move through SL junction	3

Skelton Bridge Junction		
Junction Margins		
First Movement	Second Movement	Margin
Down Passenger pass to Down Slow	Down train departs York	Same time
Down Freight pass to Down Slow	Down train departs York	1
Up Freight pass to Up Slow	Up train passes Tollerton on Up Fast	Same time
Up Fast Line train passes Skelton Junction	Up Freight pass to Up Slow	1
Up Freight pass to Up Slow	Down train departs York	1
Pass Down Fast (Skelton Junction)	Cross to Up Slow	4

Tollerton		
Adjustments to Sectional Running Times		
Movement Down	Reason	Value
Crossing from DF to DS. Approaching Tollerton	Differential junction speed	½
Crossing from DS to DF Approaching Tollerton \$ Approaching Thirsk	Differential junction speed	1* 2\$
Movement Up		
Crossing from UF to US Approaching Tollerton \$	Differential junction speed	1 ½\$
Crossing from US to UF Approaching Skelton	Differential junction speed	½
Junction Margins		
First Movement	Second Movement	Margin
Pass Up Fast	Cross Up Slow to Up Fast	3½
Cross Up Fast to Up Slow	Pass Up Fast	4
Down train pass to Down Slow	Next train passes	4
Pass Down Fast	Cross Down Slow to Down Fast	2½

Thirsk		
Adjustments to Sectional Running Times		
Movement Down	Reason	Value
Crossing from Down Slow to Down Fast * Approaching Thirsk ** Approaching Northallerton	Approach Control Acceleration	1* 1**
Movements Up	Reason	Value
Crossing from Up Slow to Up Fast Approaching Tollerton	Acceleration	1
Dwell Time		
DMU/EMU	1	
Junction Margins		

Thirsk		
First Movement	Second Movement	Margin
Down train clear to Down Slow	Next train passes	4
Pass Up Fast	Depart Up Slow to Up Fast	1½
Pass Up Fast	Pass Up Slow to Up Fast	3
Pass Down Fast	Depart Down Slow to Down Fast	2

Longlands Junction		
Junction Margins		
First Movement	Second Movement	Margin
Pass Down Main (Northallerton)	Pass from Down Slow	2
Pass Down Main (Northallerton)	Depart from Down Slow	1

Northallerton		
Dwell Time		
DMU	1	
HST/LH	1½*. * 3 when station is unstaffed	
Junction Margins		
First Movement	Second Movement	Margin
Depart to Eaglescliffe	Pass Down Main	4½
Depart to Eaglescliffe	Pass Up Main	4½
Depart to Eaglescliffe	Arrive Up Main	4
Arrive/pass Up Main	Depart to Eaglescliffe	1
Arrive/pass Up Main	Pass to Eaglescliffe	3
Pass Up Main	Pass/arrive from Eaglescliffe	3
Depart Up Main	Arrive from Eaglescliffe	4*
Passenger Pass Up Main to SL	Pass Up Main	4
Passenger Depart Up Main to SL	Pass Up Main	4½
Freight Pass Up Main to SL	Pass Up Main	5
Depart Down Platform to Up	Pass Down Main	5½
Depart Down Platform to USL	Pass Up Main	4½

* 3 if train from Eaglescliffe has pathing allowance

Darlington		
Adjustments to Sectional Running Times		
Movement Down	Reason	Value
Train to Platform 4B via Bypass Line	Slower approach speed	2
Trains from Down Main to Platform 1 – 3	Approach control	1
Trains from Up Saltburn terminating in Platforms 2 & 3	TPWS	½
Non-stop trains from Eaglescliffe to the Down Main. After Darlington	Acceleration	2
Movements Up	Reason	Value

Darlington	
Train to Platform 4B	Approach control 1

Dwell Time	
185	1½
22x	1½
XC Services (HST & 22x)	1½
DMU/EMU	2
LH/HST	2

Junction Margins

South end movements

2 nd move → 1 st move ↓	Dep to York	Pass to York	Arr from E'cliffe	Pass from York	Dep to E'cliffe	Arr Plat 4A from E'cliffe	Arr Plat 4 from York via Bypass	Arr Plat 1 – 3 from York	Arr Plat 1 from N'castle
Arr/pass from E'cliffe	1	4		4	1			4*	P
Pass to York			4		2	4			
Dep to York			5*	5	3	5*		5*	
Dep to E'cliffe	3	5	5*	5		5*		5*	
Pass from York	1		4*		1	4*			4 ½
Arr Plat 4 from York						4*			
Arr Plat 4A from Ecliffe							4		P

North End movements

2 nd move → 1 st move ↓	Pass from York	Arrive Plat 4 from York	Depart to Newcastle	Depart to Bishop Auckland	Pass to York	Arrive Plat 1 from Newcastle	Arrive Plat 4 from Newcastle	Arrive from Bishop Auckland
Pass from York			3			4 ½	4	
Dep to Newcastle				3			5*	4*
Arr Plat 1 from Newcastle	5				4			
Arr Plat 1 from Bishop Auckland			1	1		4		

Arr Plat 4A from Bishop Auckland		4 – via bypass		1			4	
Dep Plat 1 for-Bishop Auck			3 (Plat 4)			5	5*	
*These margins can be reduced by 1 if the second train has at least 1 minute pathing allowance approaching Darlington								
First Movement			Second Movement			Margin		
Arrive Up Loop			Pass Up Main			6		
Pass Up Main			Depart Up Loop			2		
Depart to Eaglescliffe			Depart Up Loop			3		
Depart to York			Depart Up Loop			3		
Minimum Turnaround								
DMU				5 for trains from Bishop Auckland and Saltburn. There must not be two consecutive 5 minute turnarounds, and the total of any two consecutive turnarounds must equal 15 minutes. These values may be reduced if sufficient pathing time is included in the schedule approaching Darlington.				
				10 trains from York				
				15 trains from Leeds or beyond				
HST				25 trains to/from Bristol/Reading and north thereof				
				35 trains to/from south of Bristol, and South Wales and beyond Reading				
LH				35 trains to/from Bristol/Reading and north thereof				
				45 trains to/from south of Bristol, and South Wales and beyond Reading				
Train Watering Points				Platforms 2 and 3				

Ferryhill South Junction

Adjustments to Sectional Running Times

Movement Down	Reason	Value
Train to Slow Line	Approach control	1 Freight 1½ DMU

Movements Up	Reason	Value
Train from Slow Line	Acceleration	1½ DMU 2 Freight

Junction Margins

First Movement	Second Movement	Margin
Down Passenger pass to SL	Next Down/Up train passes	4
Down Freight pass to SL	Next Down/Up train passes	5
Pass Up Main	Depart US or UGL to UM	2

Ferryhill South Junction		
Operating/Planning Restriction		
<ul style="list-style-type: none"> All trains booked to stand on the Up Slow Line for over 10 minutes that are less than 69 SLUs/1449 ft/441 metres, must be shown to stand in the Up Goods Loop (Line Code GL). The length of Ferryhill South Up Goods Loop is 70 SLUs/1470 ft/448 metres. Any trains standing for less than 10 minutes or that are longer than the Up Goods Loop; need to stand on the Up Slow Line (Line Code SL). 		

Tursdale Junction		
Adjustments to Sectional Running Times		
Movement Down	Reason	Value
Train from Slow Line	Acceleration	1½ DMU 2 Freight
Movements Up	Reason	Value
Train to Slow Line	Approach control	1
Junction Margins		
First Movement	Second Movement	Margin
Up Passenger passes on FL	Down Freight passes from SL	4
Up Passenger passes on FL	Down Freight departs from SL	2
Up Passenger pass to SL	Before next train passes	4
Up Freight pass to SL	Before next train passes	5
Pass to/from SL	Next train to/from SL	4
Down Freight pass/depart from SL	Up Passenger passes	3 ½
Down Passenger passes	Down Freight depart from SL	3 ½

Durham		
Adjustment to Sectional Running Times		
Movement Up	Reason	Value
Terminating train in Down platform	Approach control	½
Dwell Time		
DMU/EMU	1	
LH/HST/22x	1½	
Junction Margins		
First Movement	Second Movement	Margin
Down Passenger clear to platform/SL	Next train passes	4
Down Freight clear to platform/SL	Next train passes	5
Up train terminating shunt, arrive to DF	Next Up service pass	8
Up train arriving on Down side	Next Down/Up pass	4
Minimum Turnround		
DMU	5 trains from Newcastle area. 10 minutes must be allowed if the service is to be replatformed.	

Durham Up Loop		
Junction Margins		
First Movement	Second Movement	Margin
Up Passenger arrive inside	Next up train passes Durham	4
Up Freight arrive inside	Next up train passes Durham	5
Pass Durham on Up Main	Depart Loop	2
Depart Durham on Up Main	Depart Loop	3

Durham Down Loop		
Junction Margins		
First Movement	Second Movement	Margin
Arrive Down Loop	Next train arrives Durham	4
Pass Durham	Depart Down Loop	3
Depart Durham	Depart Down Loop	4

Chester-le-Street		
Dwell Time		
DMU(A/S)	1/2	
DMU(E)/185	1	

Birtley Junction		
Junction Margins		
First Movement	Second Movement	Margin
Down Passenger pass to SL/GL	Next Down pass	4
Down Freight pass to SL/GL	Next Down pass	5
Up Passenger from SL/GL	Next Down pass	4
Down Fast pass	Up Passenger from SL/GL	3
Up Fast pass	Up Passenger pass from SL/GL	2
Up Freight from SL/GL	Next Down pass	5
Down Fast pass	Up Freight from SL/GL	3
Up Fast pass	Up Freight from SL/GL	2
Up train from SL/GL	Down train to SL/GL	6
Down Freight to GL	Up Passenger/Freight pass from SL	6
Down Passenger/Freight to SL	Up Freight from GL	4

Low Fell Junction/RMT		
Junction Margins		
First movement	Second Movement	Margin
Up Passenger pass to SL/GL	Next Up Pass King Edward Bridge	2
Up Freight pass to SL/GL	Next Up Pass King Edward Bridge	4
Up Passenger pass to SL/GL	Next Down pass Birtley Junction	3
Up Freight pass to SL/GL	Next Down pass Birtley Junction	4

Low Fell Junction/RMT		
After Down ML passes Kingf Edward Bridge	Down Passenger from SL/GL	1
After Down ML passes Kingf Edward Bridge	Down Freight from SL/GL	2
Pass SL/GL to King Edward Bridge/Norwood Junction	Pass from King Edward Bridge / Norwood	5
Arrive Low Fell RMT from Low Fell Junction/Norwood Junction	Pass Low Fell Junction to Low Fell RMT	6
Arrive Low Fell RMT from Low Fell Junction/Norwood Junction	Pass Low Fell Junction to Norwood Junction	2
Arrive/pass from Low Fell RMT	Depart / pass to Low Fell RMT	4

King Edward Bridge South Junction		
Adjustments to Sectional Running Times		
Movement Down	Reason	Value
Trains towards Greensfield Jn	Differential junction speed	½ Passenger
Movements Up	Reason	Value
Trains from Greensfield Junction	Differential Speed Junction	½ Passenger
Junction Margins		
First Movement	Second Movement	Margin
Down pass to SL or Gateshead line	Up train pass	3
Down or Up pass	Down pass to SL or Gateshead Line	3
Pass from King Edward Bridge East/North Junction	Pass to King Edward Bridge East/North Junction	3
Pass Up Main	Pass from Norwood Junction (wrong direction)	3

King Edward Bridge North Junction		
Junction Margins		
First Movement	Second Movement	Margin
Pass from King Edward Bridge South Junction	Pass to King Edward Bridge South Junction	3

Newcastle		
Adjustments to Sectional Running Times		
Movement Down	Reason	Value
Train departing from Platforms 5,6,7 and 8 to Morpeth, timed FL. Approaching Heaton South Jn.	Differential junction speed at Argyle Street Junction	½
Trains arriving Platforms 9, 10, 11 and 12	TPWS	1
Movements Up	Reason	Value

Newcastle		
Trains arriving Platforms 5,6,7 and 8 from Morpeth timed FL. Approaching Newcastle.	Differential junction speed at Argyle Street Junction	½
Trains arriving Platform 1	TPWS	½
Connectional Allowance		
	8	
Conflicting Moves		
Movement		Margin
Between trains in the same direction Platforms 2 – 4.		4
Between arrivals from opposite directions		4
First Movement	Second Movement	Margin
Arrive lat 2 from South	Arrive Platform 1	4
Depart Plat 3 to South	Arrive Platform 4 from North	4
West End movements		
Movement		Margin
Between first arriving-and second departing		1
Between two consecutive arrivals		3
Between first departing and second arriving (LH/HST)		5
Between first departing and second arriving (DMU)		4
Between two consecutive departures		3
First Movement	Second Movement	Margin
Depart Platform 2/3 to West	Arrive Platform 2/3 from Forth Banks	4
Arrive Platform 8 from West	Arrive Platform 7 from East	3
Arrive Platform 8 from West	Depart Platform 7 to Up Slow Line	1
Arrive Platform 7 from West	Arrive Platform 8 from West	3
Depart Platform 7 to West via	Depart Platform 8 to East	2
Depart Platform 7 to Up Slow Line	Arrive Platform 8 from West	3
Depart Platform 3/4 to West	Arrive opposite Platform from East	3
Arrive Platform 3/4 from East	Depart opposite Platform to West	3
Arrive Platform 3 from down main	Arrive Platform 4 from up main	1
Arrive Platform 4 from up main	Arrive Platform 3 from down main	1
East End movements		
Movement		Margin
Between first arriving and second departing		1
Between two consecutive arrivals		3
Between two consecutive departures		3
First Movement	Second Movement	Margin
Depart to North / High Level Bridge	Arrive from North	4
Depart to North / High Level Bridge	Arrive from High Level Bridge (first via Level Bridge Central) Junction	5
Depart to North / High Level Bridge	Arrive from High Level Bridge (first via Newcastle East Junction)	4
Depart Platform 3 / 4 to North via UFL	Arrive from UF	6
Depart Platform 2 to North	Depart Platform 1 to High Level Bridge	2
Arrive /depart Platform 1	Arrive Platform 2 from South	3
Depart Platforms 5,6,7 and 8 to DFL	Arrive from North on Up Fast Line	6
Arrive from North on Up Fast Line	Depart Platform. 5,6,7 and 8 to Down Fast Line	1 min before first train arrives
Dwell Time		
DMU	2	
HST/LH	3	

Newcastle	
XC Services (22x&HST)	2
Maximum Turnround	60 minutes in through platforms
Minimum Turnround	
VTEC	35
TPE	10
XC	20 (10 by exception and in agreement with Network Rail)
DMU/EMU	5 To/from Sunderland or Metro Centre
	7 [#] To/from Hexham, Morpeth or Seaham
	10 To/from Carlisle, Hartlepool, Middlesbrough or Darlington
	20 To/from York and beyond, and north of Carlisle
# May be reduced to 5 minutes if the train has two or more minutes pathing time approaching Newcastle	
Operating Restrictions	
Class 22X trains using Platforms 5/6 must be planned to use the furthest platform dependant on the direction of arrival (i.e Platform 5 ex KEB direction and Platform 6 ex HLB/Scotland direction). No other units to be planned to use Platform 5/6 whilst a Class 22X train is occupying either platform due to overlap and signal sighting issues.	
Class 22x trains should not be planned to use Platforms 7 and 8	
Trains conveying containers should only be planned to run SL or Platform 7 or Platform 2 (in this preference) due to RT3973 restrictions through the station.	
Train Watering Points	Platforms 2, 3; restrictive use of Platforms 4, 5 and 6; Newcastle Forth Siding; Heaton Depot

Heaton South Junction		
Adjustments to Sectional Running Times		
Movement Down	Reason	Value
Trains from Slow Line	Differential junction speed	½ MU 1 Freight
Movements Up	Reason	Value
Trains to Slow	Differential junction speed	½ DMU
Junction Margins		
First Movement	Second Movement	Margin
All crossing margins		4

Benton North Junction		
Junction Margins		
First Movement	Second Movement	Margin
Pass to Branch	Up train pass Heaton South Junction	6
Up train pass Heaton South Junction	Pass to Branch	2
Off Branch	Re-occupy Branch	4
Arrive Loop from either direction		Same time
Up train depart Loop	Up train arrive Loop from Newsham	6

Morpeth		
Dwell Time		
DMU	1	
HST/LH	1½*. * To be increased to 3 when the station is unstaffed	
XC Services (HST & 22x)	1½	
Adjustments to Sectional Running Times		
Movement Down	Reason	Value
Junction Margins		
First Movement	Second Movement	Margin
Passenger arrive Down Loop (Morpeth North Jn)	Pass Morpeth Down Main	1½
LH Freight arrive Down Loop (Morpeth North Jn)	Pass Morpeth Down Main	3½
Down terminating train to Branch	Down/Up non-stop pass	5
Down Freight pass to Branch	Down/Up non-stop pass	6
Up Passenger pass Morpeth	Arrive from reversing siding	3
Up Passenger arrive Up Loop	Up non-stop pass	6
Up Freight arrive Up Loop	Up non-stop pass	7
Pass from Branch	Pass to Branch	4
Minimum Turnround	10 Shunt via sidings	

Morpeth North Junction		
Junction Margins		
First Movement	Second Movement	Margin
Depart pass from Branch	Up pass Morpeth	6
Pass to Branch	Up pass Morpeth	7
Pass from Branch	Up pass Morpeth	4
Down Passenger pass Morpeth	Depart Down Loop	2
Up train pass Morpeth	Depart from Branch	1
Down Passenger pass Morpeth	Depart from Branch	2

Pegswood		
Dwell Time		
DMU	½	

Butterwell Junction		
Junction Margins		
First Movement	Second Movement	Margin
Up Passenger train passes Alnmouth	Pass to branch (before Up train)	5
Up Freight train passes Alnmouth	Pass to Branch (before Up train)	9
Up train passes/arrives Morpeth/Morpeth UPL (or Morpeth North if going to Blyth & Tyne)	Depart/Pass Down Main to Branch	Same time

Widdrington	
Dwell Time	
DMU	½

Chevington Loops		
Junction Margins		
First Movement	Second Movement	Margin
Down passenger arrive	Non-stop pass Morpeth	4 mins after
Down freight arrive	Non-stop passes Morpeth	2 mins after before
Down passenger pass Morpeth	Down depart Loop	8
Up passenger arrive	Non stop pass Alnmouth	Same time
Up freight arrive	Non stop pass Alnmouth	1

Acklington	
Dwell Time	
DMU	½

Wooden Gates		
Junction Margins		
First Movement	Second Movement	Margin
Down Passenger arrive	Non stop passes Alnmouth	6
Down Freight arrive	Non stop passes Alnmouth	7
Down Passenger arrive	Down Passenger arrive Alnmouth	4
Down Freight arrive	Down Passenger arrive Alnmouth	5
Down Passenger pass Alnmouth	Down depart Loop	1

Alnmouth for Alwick (inc Wooden Gates loops)		
Dwell Time		
DMU	1	
HST/LH	1½*. * To be increased to 3 when the station is unstaffed	
XC Services (HST & 22x)	1½	
Junction Margins		
First Movement	Second Movement	Margin
Up Passenger clear inside	Non stop pass	5
Up Freight clear inside	Non stop pass	6

Chathill	
Dwell Time	
DMU	½

Belford (inc Crag Mill Loops)		
Junction Margins		
First Movement	Second Movement	Margin
Down Passenger clear inside	Down non stop pass	5
Down Freight clear inside	Non stop pass	6

Crag Mill Loops		
Junction Margins		
First Movement	Second Movement	Margin
Up Passenger clear inside	Non stop passes Belford	5
Up Freight clear inside	Non stop spasses Belford	6
Down Passenger pass Belford	Freight depart Down Loop	2
Up Passenger pass Belford	Freight depart Up Loop	1

Tweedmouth		
Junction Margins		
First Movement	Second Movement	Margin
Up Freight clear inside	Non stop passes Berwick from Scotland	6

Berwick		
Dwell Time		
HST/LH	1½	
Junction Margins		
First Movement	Second Movement	Margin
Down Freight clear inside	Non stop pass	6
Up Freight clear inside	Non stop pass	6
Depart Up Main	Pass Up Main	6

LN626 NORTHALLERTON HIGH JUNCTION TO NORTHALLERTON EAST JUNCTION		
Notes:		
<ul style="list-style-type: none"> No pathing to be inserted between Northallerton East Junction and Northallerton station in either direction; if necessary an 'A' stop must be inserted at signal Y478 in Up direction or Northallerton East Junction in Down direction An up train standing at signal Y478 must not exceed 380m A down train standing at Northallerton East Junction must not exceed 210m 		

LN627 LONGLANDS JUNCTION TO NEWCASTLE EAST JUNCTION VIA THE COAST

Northallerton East Junction

Adjustment to sectional running times

Movement Up	Reason	Value
Trains booked to stop at Y478. To be applied approaching Northallerton East Junction	Slow approach	½ passenger and light engines only

Movement Down	Reason	Value
Trains from Northallerton station. To be applied after Northallerton East Junction	Accelaration	½ (except as shown below)

Junction Margins

First Movement	Second Movement	Margin
Pass to Boroughbridge Road LC occupy tc DCT to clear tc DCT	Depart Northallerton Down Loop to Eaglescliffe	1½
Pass to Boroughbridge Road LC occupy tc DCT to clear tc DCT	Pass from Northallerton Down Loop Sight Y467 (approach control) to occupy tc DDT	3½
Passenger pass from Northallerton Occupy tc DDT/clear tc DCT	Depart to Boroughbridge Road LC	1½
Passenger pass from Northallerton Occupy tc DDT/clear tc DCT	Pass to Boroughbridge Road LC	3
Freight pass from Northallerton Occupy tc DDT/clear tc DCT	Depart to Boroughbridge Road LC	2
Freight pass from Northallerton Occupy tc DDT/clear tc DCT	Pass to Boroughbridge Road LC	3½

Adjustment to Sectional Running Times for heavier freight traffic:

TR100 timing loads = {1}
 TR115 and above timing loads = {1½}
 Class 60 timing loads 1400-1600t = {1}
 Class 60 timing loads 1800t and above = {1½}
 Class 66 timing loads 2000-2400t = {1}
 Class 66 2600t and above = {1½}

Yarm

Adjustment to sectional running times

Movement Both Directions	Reason	Value
RT3973 HAW: Schedule 2 and/or 3 vehicles; apply between Yarm and Eaglescliffe and Vice Versa	20mph restriction over Yarm Viaduct	2

Eaglescliffe

Eaglescliffe		
Adjustment to Sectional Running Times		
Movement Down	Reason	Value
Non-stop trains from Darlington * After Eaglescliffe	Differential junction speed	1 Passenger 2 Freight*
Movement Up	Reason	Value
Non-stop trains towards Darlington ** Approaching Eaglescliffe	Approach control	1 Passenger 2 Freight**
Junction Margins		
First Movement	Second Movement	Margin
Pass/arrive from Northallerton	Depart to Darlington	1
Pass/arrive from Northallerton	Pass to Darlington	3
Pass/depart to Darlington	Pass/arrive from Northallerton	4

Stockton Cut Junction
Refer to LN632

Hartburn Junction		
Junction Margins		
First Movement	Second Movement	Margin
Pass from Bowesfield Junction	Pass to Stockton Cut Junction	3
Pass to Stockton Cut Junction	Pass from Bowesfield Junction	3

Stockton		
Junction Margins		
First Movement	Second Movement	Margin
Depart Down platform to south	Arrive Down platform from south	4
Minimum Turnround	5 Trains from Newcastle, Sunderland, Middlesbrough, Saltburn or Darlington	

Norton Junctions		
Junction Margins		
First Movement	Second Movement	Margin
All conflicting moves		4

Billingham/Billingham Junction		
Junction Margins		

Billingham/Billingham Junction		
First Movement	Second Movement	Margin
Pass to Branch	Depart Billingham	3
Pass to Branch	Pass Billingham	4
Pass/depart Billingham	Pass to Branch	4

Greatham		
Adjustment to Sectional Running Times : Up Direction		
Coming from various Works sites on Down Side	Acceleration from Slow Speed crossover	1
Junction Margins		
First Movement	Second Movement	Margin
Down depart to Works sites on Down Side	Pass Billingham Junction	4
Down pass to Hartlepool	Depart Works site on Down Side	Same time
Down pass from Hartlepool	Depart Works site on Down Side	Same time
Pass from Works sites on Down Side	Down pass to Hartlepool	4½
Pass from Works sites on Down Side	Down arrive, going to Works sites on Down Side	5½
Restrictions:		
<ul style="list-style-type: none"> Trains leaving Down line, going to various Works sites on Down side, require a 30 second 'OP' stop at Greatham 		

Seaton Snook Junction /Seaton Carew		
Junction Margins		
First Movement	Second Movement	Margin
Up depart to branch from Up main	Up arrive Seaton Carew	4½
Up depart to branch from Down main	Up depart Seaton Carew	2
Up depart to branch from Up or Down Main	Up pass Greatham (not stopping Seaton Carew)	6
Up depart to branch from Down main	Down pass Greatham	2
Up pass Greatham	Up depart to branch from Down main	½
Pass from branch	Up arrive Seaton Carew	4½
Pass from branch	Up pass Greatham (not stopping Seaton Carew)	6
Down Depart Seaton Carew to Hartlepool	Up depart DGL	2½
Down pass Greatham to Hartlepool (not stopping Seaton Carew)	Up depart DGL	4
Down Depart Seaton Carew to Hartlepool	Down depart DGL	3½
Down pass Greatham to Hartlepool (not stopping Seaton Carew)	Down depart DGL	5
Restrictions:		
<ul style="list-style-type: none"> Trains going to Seaton on Tees branch require a 1 minute OP Stop at junction Only one train at a time allowed on Seaton on Tees branch 		

Hartlepool		
Dwell Time		
All Southbound	1	
All Northbound	1½	

Hartlepool		
Junction Margins		
First Movement	Second Movement	Margin
Depart/pass to Newcastle	Arrive platform from Newcastle	4
MU Depart platform to Stockton	Arrive/pass from Stockton	5½
HST/LH Depart platform to Stockton	Arrive/pass from Stockton	6
Pass To/from Hartlepool Docks	Arrive/pass from Newcastle	7
Pass Up on Up Line	Depart to Hartlepool Docks	1
Pass Up on Up Line	Pass to Hartlepool Docks	2
Minimum Turnround		
	5 Trains from Newcastle or Sunderland 10 All other trains	
Restrictions:		
<ul style="list-style-type: none"> Hartlepool Docks: only one train at a time on branch (presently out of use) Services terminating in the through platform should not be planned to shunt to another location 		

Seaham		
Junction Margins		
First Movement	Second Movement	Margin
Depart/pass to Hartlepool	Depart Seaham Harbour	2½
Pass from Seaham Harbour	Up Depart Seaham	1½
Pass from Seaham Harbour	Up Pass to Hartlepool	2
Depart to Seaham Harbour	Up arrive/Up pass to Hartlepool	6½
Minimum Turnround		
	10 via Dawdon	
Restrictions:		
<ul style="list-style-type: none"> Up goods trains going to Seaham Harbour require a 30 second 'OP' stop at Seaham station Seaham Harbour: only one train at a time on branch		

Ryhope Grange		
Adjustments to Sectional Running Times		
Movement Down	Reason	Value
Going from Ryhope Grange Sidings	Acceleration from slow speed	1
Movement Up		
Going to Ryhope Grange Sidings	Approach Control	1
Junction Margins		
First Movement	Second Movement	Margin
Depart to Hendon Branch	Pass Up	3½
Pass to Ryhope Grange Sidings	Pass Down	4½
Restrictions		
<ul style="list-style-type: none"> Hendon Branch, one train Token Working. A 'TW' stop is required for all traffic to/from the Branch (Note: line currently Out Of Use) If a train is being propelled out of Ryhope Grange Sidings, no Up trains can pass. Margin of 1" before movement commences is acceptable; otherwise a train from Sunderland must follow train towards Seaham (Note: Sidings currently Out of Use) 		

Sunderland		
Dwell Time		
Multiple Unit	1	
Up class 5, departing class 1 in same direction	4	
Down class 1, departing class 5 in same direction	4	
Metro Services	½	
Junction Margins		
First Movement	Second Movement	Margin
Depart to South Hylton/Sidings	Down Heavy Rail Passenger Arrive ex Hartlepool	4
Depart to South Hylton/Sidings	Down Freight pass	4
Depart to South Hylton	Depart Sidings	2
Down Arrive from Hartlepool (except trains longer than 178m, see restrictions below)	Depart to South Hylton/Sidings	1 #
Down Depart from platforms 3 or 4	Up Arrive into platforms 3 or 4	3½
Up Metro arrive (platform 2)	Up Heavy Rail (Under 70metres) arrive platform 1	2½
Metro depart to South Hylton/Sidings	Up passenger pass	2
Metro depart to South Hylton/Sidings	Up freight pass	5
Down Heavy Rail (under 69 metres) arrive platform 4	Metro depart from Park Lane	1
Down Heavy Rail (over 69 metres) depart from platform 4 clear tc	Metro depart from Park Lane	2
Down Heavy Rail (under 69metres) depart from platform 4	Down Metro depart to Pelaw from platform 3	2
Up freight pass	Up Metro Arrive	3½
Down depart	Down freight Pass	4
#May be reduced to ½ if Down train is MU under 69 metres or Light Loco		
Minimum Turnround	5 Same platform (8 minutes for trains from York or south thereof, arriving and returning as class 1; trains 178m or longer cannot reverse in station to/from south)	
All shunts to be timed for ARS purposes	8 Via sidings	
<ul style="list-style-type: none"> A train longer than 195m which has terminated from the Boldon direction or 178m from the Ryhope direction, running into platforms 3/4 will follow the route to and from South Hylton. This train must depart towards Boldon at least 1½ minutes before the next Metro departs towards South Hylton A train longer than 195m cannot depart southbound from platforms 3/4, except by prior agreement between the Train operator and the Local Operations Manager, as train rear of the train will 'lock' the crossovers at the north end of the station, preventing moves to/from other platforms A train longer than 195m can only arrive into platforms 1/2 from Ryhope Grange by prior agreement between the Train operator and the Local Operations Manager as the rear of the train will 'lock' the crossovers at the south end of the station, preventing moves to/from other platforms Metro trains can only use No. 2 Siding; the other siding IS NOT electrified 		

East Boldon Up Loop		
Junction Margins		
First Movement	Second Movement	Margin
Arrive	Up Metro depart/up passenger pass Brockley Whins/Up freight from Pelaw pass Boldon West Junction	½
Arrive	Up freight from Tyne pass Boldon East Junction	Same time*
Up Metro depart East Boldon	Depart	2½
Up passenger pass Brockley Whins (not stopping Boldon or Seaburn)	Depart	4
Up freight from Pelaw pass Boldon West Junction/from Tyne pass Boldon East Junction going to Sunderland	Depart	10
Depart	Reoccupy Loop	5½
Note: *No Allowances to be applied between Boldon North Junction and Boldon East Junction		

Boldon East Junction		
Junction Margins		
First Movement	Second Movement	Margin
Pass/depart to Boldon North	Up Metro depart Brockley Whins	2½
Pass/depart to Boldon North	Up passenger/light loco pass Brockley Whins	3½
Pass/depart to Boldon North	Up freight pass Boldon West Junction to Sunderland	3½
Pass/depart to Boldon North	Down Metro arrive Brockley Whins	4
Pass/depart to Boldon North	Down passenger pass Brockley Whins	3½
Pass/depart to Boldon North	Down freight from Sunderland pass Boldon West Junction	6
Up Metro depart Brockley Whins	Pass to Boldon North	2½
Up passenger/light loco pass Brockley Whins	Pass to Boldon North	2
Up freight pass Boldon West Junction to Sunderland	Pass to Boldon North	3½
Up Metro depart Brockley Whins	Depart to Boldon North	2
Up passenger/light loco pass Brockley Whins	Depart to Boldon North	1½
Up freight pass Boldon West Junction to Sunderland	Depart to Boldon North	3
Freight from Tyne passes Boldon West towards Pelaw (see Restrictions)	Pass to Boldon North	3
Freight from Tyne passes Boldon West towards Pelaw (see Restrictions)	Depart to Boldon North	2½
Up freight pass from Tyne Dock	Up Metro arrive Brockley Whins (see Restrictions)	6
Up freight pass from Tyne Dock	Up passenger pass Brockley Whins (see Restrictions)	5½
Up freight pass from Tyne Dock	Up freight pass Boldon West going to Sunderland (see Restrictions)	6
Pass from Boldon North	Pass to Boldon North	3
Pass from Boldon North	Depart to Boldon North	2
Up Metro depart Brockley Whins	Depart/pass Boldon North towards Boldon East	3
Up passenger/light loco pass Brockley Whins	Depart/pass Boldon North towards Boldon East	2
Up freight pass Boldon West Junction to Sunderland	Depart/pass Boldon North towards Boldon East	4½

Boldon East Junction

Restrictions:

- Once a train has departed/passed Boldon North Junction, irrespective of route (i.e. via Boldon East or via Boldon West), NO OTHER TRAIN can leave the Sunderland lines towards Boldon North Junction from any direction, until first train is clear onto Sunderland lines – see margins above
- Trains cannot stand on Boldon East Curve; there is no signaling on the Curve to allow this. No allowances to be applied between Boldon East and Boldon North Junctions in either direction
- A freight train from Tyne Dock or Pelaw must clear overlap of signal T6252 before a following train can pass signal T6266 – reflected in margins above

Boldon West Junction/Brockley Whins

Adjustments to Sectional Running Times

Movement Down	Reason	Value
Trains from Tyne Dock Branch Approaching Pelaw Junction	Acceleration	1

Movement Up	Reason	Value
Up trains going to Boldon North	Approach Control	½*

*To be increased to 1 minute if a train has emerged from branch in previous 6 minutes, due to overlap issues

Junction Margins

First Movement	Second Movement	Margin
Down passenger/light loco pass from Sunderland	Depart/pass Boldon North towards Pelaw	1½
Down freight pass from Sunderland	Depart/pass Boldon North towards Pelaw	3
Down Metro depart Fellgate	Depart/pass Boldon North towards Pelaw	1
Up passenger/light loco pass Brockley Whins	Depart/pass Boldon North towards Pelaw	1
Up Metro arrive Brockley Whins	Depart/pass Boldon North towards Pelaw	1
Up freight pass towards Sunderland	Depart/pass Boldon North towards Pelaw	2
Up freight pass towards Tyne Dock	Up freight pass towards Sunderland	4
Up freight pass towards Tyne Dock	Up passenger pass	3
Up freight pass towards Tyne Dock	Up Metro depart Fellgate	1½
Pass from Boldon North	Up Metro depart Fellgate	2
Pass from Boldon North	Up passenger/light loco pass Brockley Whins	4
Pass from Boldon North	Up freight pass Boldon West to Sunderland	4½
Pass from Boldon North	Up freight pass Boldon West to Boldon North	3
Pass Boldon North towards Sunderland (see Restrictions)	Pass Boldon West to Boldon North	3½
Depart Boldon North towards Sunderland (see Restrictions)	Pass Boldon West to Boldon North	5½

Restrictions:

- Once a train has departed/passed Boldon North Junction, irrespective of route (i.e. via Boldon East or via Boldon West), NO OTHER TRAIN can leave the Sunderland lines towards Boldon North Junction from any direction, until first train is clear onto Sunderland lines – see margins above
- Trains cannot stand on Boldon West Curve; there is no signaling on the Curve to allow this. No allowances to be applied between Boldon West and Boldon North Junctions in either direction

Pelaw Metro Junction
Junction Margins – See Pelaw Junction

Pelaw Junction (including Pelaw Metro Junction)		
Adjustments to Sectional Running Times		
Movement Down	Reason	Value
Trains into Pelaw Goods Loops Approaching Pelaw Jn	Approach Control	½
Movement Up	Reason	Value
Trains from Pelaw Goods Loops After Pelaw Junction	Acceleration from rest	2 (1 MU)
Trains going to Jarrow or Wardley. Approaching Pelaw Junction	Slowing for junction	½
Junction Margins		
First Movement	Second Movement	Margin
Pass Pelaw Junction to Wardley	Pass Passenger/light engine pass Pelaw Junction from Sunderland to Heworth	3
Pass Pelaw Junction to Wardley	Freight pass Pelaw Junction from Sunderland to Heworth	3½
Pass Pelaw Junction to Wardley	Pass Pelaw Junction to Up or Down Goods Loop	2½
Depart Pelaw Junction (on Up Main) to Wardley	Passenger/light engine pass Pelaw Junction from Sunderland to Heworth	4
Depart Pelaw Junction (on Up Main) to Wardley	Freight pass Pelaw Junction from Sunderland to Heworth	5
Depart Pelaw Junction (on Up Main) to Wardley	Pass Pelaw Junction to Up or Down Goods Loop	3½
Freight pass from Jarrow	Up depart Heworth	2½
Light Engine pass Pelaw Junction from Jarrow	Up depart Heworth	1½
Freight pass Pelaw Junction from Jarrow	Pass Pelaw Junction to Boldon (not stopping Heworth)	3
Light Engine pass Pelaw Junction from Jarrow	Pass Pelaw Junction to Boldon (not stopping Heworth)	2
Freight pass Pelaw Junction from Jarrow	Pass Pelaw Junction to Jarrow/Wardley	2
Light Engine pass Pelaw Junction from Jarrow	Pass Pelaw Junction to Jarrow/Wardley	1
Freight pass Pelaw Junction from Jarrow	Depart Loop to Jarrow/Wardley/Boldon	2½
Light Engine pass Pelaw Junction from Jarrow	Depart Loop to Jarrow/Wardley/Boldon	1½
Pass Passenger/light engine pass Pelaw Junction to Sunderland	Up Metro Pass Pelaw Metro Jn to Sunderland	2½
Up Freight pass Pelaw Junction to Sunderland	Up Metro pass Pelaw Metro Jn to Sunderland	4
Down Metro Pass Pelaw Metro Jn from Sunderland	Down passenger/light engine Pass Pelaw Junction from Sunderland	3
Down Metro pass Pelaw Metro Jn from Sunderland	Down freight pass Pelaw Junction from Sunderland	3½
Up Metro Pass Metro Jn to Sunderland	Up Passenger/light engine pass Pelaw Junction to Sunderland	2½
Up Metro Pass Metro Jn to Sunderland	Up Freight pass Pelaw Junction to Sunderland	2
Down Pass Pelaw Junction from Sunderland	Down Metro Pass Pelaw Metro Jn from Sunderland	2
Down depart Heworth	Down pass Pelaw Junction from Jarrow or Wardley	3
Down depart Heworth	Down depart loop	2½

Pelaw Junction (including Pelaw Metro Junction)		
Passenger/light engine Down pass Pelaw Junction to Heworth (not stopping)	Down depart loop/pass Pelaw Junction from Jarrow or Wardley	3½
Up arrive loop	Up freight pass Pelaw Junction	3½
Up arrive loop	Up passenger pass Pelaw Junction (not stopping Heworth)	2
Pass Pelaw Junction to Jarrow/Wardley	Up depart loop to Boldon	2
Passenger/light engine pass Pelaw Junction to Boldon	Up depart loop to Boldon	2
Freight pass Pelaw Junction to Boldon	Up depart loop to Boldon	3½
Down train arrive Up Goods Loop	Up pass towards Boldon (not stopping Heworth)	2
Down train arrive Up Goods Loop	Up pass towards Jarrow/Wardley	1
Down train arrive Up Goods Loop	Up depart Heworth	½
Down pass	Up train depart Down Goods Loop	1½
Up train depart Down Goods Loop	Down passenger/light engine pass	3
Up train depart Down Goods Loop	Down freight pass	3½
Up train depart Down Goods Loop	Pass from Jarrow/Wardley	2½
Up train depart Down Goods Loop	Down train arrive either loop	3½
Restrictions:		
<ul style="list-style-type: none"> Jarrow branch – only one train can be planned between Jarrow and Pelaw Junction at any one time Class 5 reversals in Goods Loop – the loop used must be specified and timed accordingly 		

Heworth	
Dwell Time	
All	1 Up ½ Down

Park Lane Junction		
Junction Margins		
First Movement	Second Movement	Margin
Pass from Greensfield Junction/King Edward Bridge East Junction	Pass to High Level Bridge Junction	3
Depart from Greensfield Junction/King Edward Bridge East Junction	Pass to High Level Bridge Junction	4½
Pass from Greensfield Junction/King Edward Bridge East Junction	Pass to Greensfield Junction/King Edward Bridge East Junction	2½
Depart from Greensfield Junction/King Edward Bridge East Junction	Pass to Greensfield Junction/King Edward Bridge East Junction	4
Pass to Greensfield Junction/King Edward Bridge East Junction	Pass from Greensfield Junction/King Edward Bridge East Junction	5
Pass to Greensfield Junction/King Edward Bridge East Junction	Depart from Greensfield East or Gateshead line towards Pelaw	2½
Pass to Greensfield Junction/King Edward Bridge East Junction	Pass to High Level Bridge Junction	3½
Pass to High Level Bridge Junction	Pass from Greensfield Junction/King Edward Bridge East Junction	4
Pass to High Level Bridge Junction	Depart from Greensfield Junction/King Edward Bridge East Junction	1½
Pass from High Level Bridge Junction	Depart from Greensfield Junction/King Edward Bridge East Junction	2½

Park Lane Junction

Restrictions:

- No allowances or pathing time to be applied between Greensfield Junction and Park Lane Junction; an 'A' stop must be applied at Park Lane Junction
- Maximum length of train which can stand at Park Lane Junction (on Greensfield East Line) is 630m

High Level Bridge Junction

Junction Margins

First Movement	Second Movement	Margin
Pass to Greensfield Junction	Pass from Park Lane Junction	2½
Up pass from Down Sunderland (crossing over High Level Bridge Central Junction to Up Sunderland)	Pass from Park Lane Junction going to Newcastle on Down Sunderland	2
Up pass from Down Sunderland (crossing over High Level Bridge Central Junction to Up Sunderland)	Pass from Greensfield Junction	2
Pass from Park Lane Junction	Pass to Greensfield Junction	2½

Restriction

- Freights RA6 and above must not be planned to cross the High Level Bridge. Also no freight service RA6 and above can be planned to use the curve between Greensfield Junction and High Level Bridge Junction. The above restriction also applies to all movements involving class 67 locomotives
- No allowances or pathing time to be applied between Greensfield Junction and High Level Bridge Junction; an 'A' stop must be applied at High Level Bridge Junction
- Maximum length of train which can stand at High Level Bridge Junction (on West Curve) is 190m

LN628 SOUTH HYLTON TO SUNDERLAND SOUTH JUNCTION

South Hylton

Platform Re-occupation	3
Minimum Turnround	4

Park Lane

Junction Margins

First Movement	Second Movement	Margin
Arrive from Sunderland	Depart, going to platform 1 or 2 at Sunderland	½

LN631 DARLINGTON SOUTH JUNCTION– EAGLESCLIFFE SOUTH JUNCTION

Eaglescliffe

Refer to LN627

LN632 STOCKTON CUT JUNCTION TO SALTBURN

Stockton Cut Junction

Junction Margins

First Movement	Second Movement	Margin
Pass from Hartburn Junction	Pass to Bowesfield Junction	3
Pass to Bowesfield Junction Junction	Pass from Hartburn Junction	4

Bowesfield Junction

Junction Margins

First Movement	Second Movement	Margin
Pass to Hartburn Junction	Pass from Stockton Cut Junction	4
Pass from Stockton Cut Junction	Pass to Hartburn Junction	2½

Thornaby

Junction Margins

First Movement	Second Movement	Margin
Pass/arrive from Bowesfield Junction	Pass from GL	4
Pass from GL	Pass/arrive from Bowesfield Junction	4
Pass from GL	Pass to GL	5

Newport East Junction

Junction Margins

First Movement	Second Movement	Margin
Cross ML to GL (either direction)	Pass/depart Thornaby	Same time
Arrive Middlesbrough	Cross GL to ML (either direction)	Same time

Middlesbrough

Connectional Allowance	5
-------------------------------	---

Dwell Time

All	1
-----	---

Junction Margins

Middlesbrough		
First Movement	Second Movement	Margin
Arrive Down platform	Arrive Down platform from opposite direction	3
Depart Down platform to west	Arrive Down platform from west	4½
Depart Down platform to west	Arrive Up platform	3 [#]
Arrive Up platform	Depart Down platform to west	3 [#]
Arrive Up platform	Shunt Down platform to West Dock	1
Terminate Down platform	Arrive second train	7*
# Can be simultaneous if Arrival into Up platform is given 1 adjustment between Guisborough Junction and Middlesbrough		
* May be reduced by 1 minute if ECS of first train is via Guisborough Junction.		
Minimum Turnround		
	5 Trains from Saltburn, Whitby, or Bishop Auckland There must not be two consecutive 5 minute turnrounds, and the total of any two consecutive turnrounds must equal 15 minutes. These values may be reduced if sufficient pathing time is included in the schedule approaching Middlesbrough	
	7½ ^{\$} Trains from Newcastle & Metro Centre	
	10 ^{\$} Trains from and Hexham	
	15 Trains from Carlisle ^{\$}	
TPE	10 (same platform) 12 (shunt)	
\$ These times may be reduced by the amount of pathing time south of Sunderland or additional dwell time at Sunderland or Hartlepool to a minimum of 5 mins		
Restrictions		
185 shunts to West Dock limited to 1x3 car set and only one to do this at a time.		
Train Watering Points		
	Station and down sidings	

Guisborough Junction		
Junction Margins		
First Movement	Second Movement	Margin
Pass to Whitby	Pass from Redcar	3
Pass from Redcar	Pass to Whitby	2

Whitehouse Junction		
Junction Margins		
First Movement	Second Movement	Margin
Cross ML to GL	Depart Middlesbrough	2 before
Cross GL to ML	Cross ML to GL	4

South Bank Junction		
Junction Margins		
First Movement	Second Movement	Margin
Cross ML to GL	Depart Middlesbrough	Same time
Cross to/from GL	Cross to/from GL	4
Down Passenger pass Guisborough Junction	Up Freight crosses Up Goods to Up Main	6

South Bank Junction		
Restrictions		
All freights that require to run-round at South Bank should be shown to do so at South Bank station (due to TRUST reporting). When the run-round is taking place no other train should be timed on the Goods Lines between South Bank Junction and Grangetown Junction.		

Grangetown Junction		
Junction Margins		
First Movement	Second Movement	Margin
Cross to ML	Cross to GL	4
Cross ML to GL	Pass Guisborough Junction	Same time
Down Passenger service passes Guisborough Junction or departs South Bank	Up Freight routed ML to GL passes Redcar Central	Same time
Restrictions		
When a run-round is taking place at Grangetown no other train should be timed on the Goods Lines between South Bank Junction and Grangetown Junction.		

Redcar Central		
Dwell Time		
All	1	
Junction Margins		
First Movement	Second Movement	Margin
Depart Down platform to the West	Arrive Down platform from the West	5
Minimum Turnround	5 There must not be two consecutive 5 minute turnrounds, and the total of any two consecutive turnrounds must equal 15 minutes. These values may be reduced if sufficient pathing time is included in the schedule approaching Redcar	
Restrictions		
Trains to Crag Hall cannot pass or depart until the previous train has arrived at Crag Hall, or the train from Crag Hall has passed Saltburn West Junction		

Saltburn West Junction		
Junction Margins		
First Movement	Second Movement	Margin
Pass from Saltburn	Pass to Saltburn/Boulby	3
Pass to Boulby	Pass from Saltburn	4

Saltburn		
Minimum Turnround	5 There must not be two consecutive 5 minute turnrounds, and the total of any two consecutive turnrounds must equal 15 minutes. These values may be reduced if sufficient pathing time is included in the schedule approaching Saltburn	

LN634 GUISBOROUGH JUNCTION TO WHITBY

The route between Nunthorpe and Whitby is under the control of a single signaller at Nunthorpe signalbox. Therefore token exchanges between Nunthorpe and Whitby cannot happen simultaneously, irrespective of actual locations; arrivals therefore, at any location, must be a minimum of 1 minute apart

Guisborough Junction

Refer to LN632

James Cook

Dwell Time

All	½
-----	---

Marton

Dwell Time

All	½
-----	---

Gypsy Lane

Dwell Time

All	½. Compulsory stop on Down only
-----	---------------------------------

Nunthorpe

Crossing Margin

Down train must arrive 3 minutes before Up service. An Up train cannot arrive in platform when a Down train has been accepted from Middlesbrough

Dwell Time

All	½
-----	---

First Movement

Arrive from Middlesbrough

Second Movement

Depart to Middlesbrough

Margin

1

Arrive from Battersby

Depart to Battersby

1

Minimum Turnround

5 in same platform
3 at signal N1

Restrictions:

A down train cannot pass Guisborough Junction whilst a train is on line to Nunthorpe, or occupying platform 2 at Nunthorpe; if a down train needs to come onto the line in these circumstances, then the first train must shunt to Platform 1, via signal N1. These shunt moves must be fully timed BUT cannot occur if a train is on line between Nunthorpe and Battersby in either direction

Great Ayton	
Dwell Time	
All	½.

Battersby		
Adjustments to Sectional Running Times		
Arriving when earlier train already in the platform	Calling on signal	½
Crossing/Reversing Margin		
	First arriving train departs second	13½
Example:		
1 st Train arrive	arr. Xx.00	
2 nd Train arrive	arr. Xx.05	
2 nd Train depart	dep. Xx.08½	
1 st Train depart	dep. Xx.13½	
Dwell Time		
All	3½ (minimum required for train reversing and not crossing another service)	
Restrictions:		
<ul style="list-style-type: none"> Trains arriving from either direction can only be planned into the platform and NOT directly into the Run Round loop Due to the operation of two Ground Frames, any run round must be allowed a minimum of 30 minutes. When the locomotive is moving from the run round loop onto the east end of the train, the driver must be in possession of the token for either the Glaisdale or Nunthorpe section; planners must satisfy themselves that there are no trains moving in either direction on the relevant section 		
Notes:		
<ul style="list-style-type: none"> Trains crossing at Battersby occupy the same section of track and platform and must have 5 minutes between consecutive arrivals and departures due to TPWS requirements Trains passing do so by utilizing the permissive working on the platform line. Planners must satisfy themselves of the lengths of both trains, and that they both can be accommodated according to the platform length AND the distances quoted below Platform and runround loop, stop board to stop board = 175m Buffer stops to east end stop board = 325m 		

Kildale	
Dwell Time	
All	½.

Comondale	
Dwell Time	
All	½

Castleton Moor	
Dwell Time	
All	½

Danby	
Dwell Time	
All	½* * 1 for 07XX Middlesbrough to Whitby/16XX Whitby to Middlesbrough

Glaisdale	
Dwell Time	
All	3 when trains do not cross
	5 when train cross
<p>Note: Arrive/depart margin depends on sequence on which each driver relinquishes token, as follows:</p> <ul style="list-style-type: none"> • Xx:00. 1st train arrive, relinquishes token • Xx:01: 2nd train arrive, relinquishes token; collects token • Xx:05: 1st train collects token and departs • Xx:06: 2nd train departs <p>Although trains can arrive simultaneously, a minimum of 1 minute difference must be shown as signaller cannot communicate with two or more drivers at once</p>	

Egton	
Dwell Time	
All	½* * 1 for 07XX Middlesbrough to Whitby/16XX Whitby to Middlesbrough

Grosmont		
Dwell Time		
All	1	
Junction Margins		
First Movement	Second Movement	Margin
Arrives Glaisdale from Grosmont direction.	NYMR train departs Grosmont towards Whitby	5
NYMR train arrives Grosmont from Whitby	Depart Glaisdale towards Grosmont direction.	5
NYMR train arrives Grosmont from Whitby	NYMR train departs Grosmont towards Whitby	6
<p>Note: Trains going to/from NYMR must stop to main line to operate Ground Frame. However, this activity is allowed for in Sectional Running Times</p>		

Sleights	
Dwell Time	
All	1 Compulsory stop on Down (Eastbound) only ½ (westbound, when stopping, not compulsory stop)

Ruswarp	
Dwell Time	
All	½*. Compulsory stop Up (Westbound) only * 1 for 07XX Middlesbrough to Whitby/16XX Whitby to Middlesbrough

Whitby		
Minimum Turnround		
	8 MU 20 LH 15 NYMR LH	
Junction Margins		
First Movement	Second Movement	Margin
Up NYMR train arrives Grosmont	Up train depart Whitby, going to Glaisdale	5
Down arrive Whitby	Up depart Whitby	10
Notes:		
<ul style="list-style-type: none"> Whitby platform 2, buffer stops to ground frame = 243m Bog Hall Sidings: Trap points to buffer stop = 335m; run round loop 170m (fouling foot crossing) or 158m (not fouling foot crossing) Trains in platform 2 can run round without impacting on traffic to/from platform 1. Due to operation of ground frame, 20 minutes must be allowed. 		

LN652 BILLINGHAM JUNCTION TO SEAL SANDS STORAGE	
Belasis Lane	
Operating Stop	2 All trains running to/from Port Clarence for purpose of token exchange.

Phillips Loops	
Operating Stop	6 Light Engine in either direction: opening/closing of gates, operation of GF 15 Outbound freight trains: opening/closing of gates, operation of GF 60 Inbound freight trains: shunting of train [GBRf only]

LN666 BOLDON WEST JUNCTION TO TYNE DOCK		
Boldon North Junction		
Junction Margins		
First Movement	Second Movement	Margin
Pass from Boldon East Junction or Boldon West Junction	Depart to Boldon East Junction or Boldon West Junction	3
Pass from Boldon East Junction or Boldon West Junction	Pass to Boldon East Junction or Boldon West Junction	4
Restrictions:		
Once a train has departed/passed Boldon North Junction, irrespective of route (ie via Boldon East or via Boldon West), NO OTHER TRAIN can leave the Sunderland lines towards Boldon North Junction from any direction, until first train is clear onto Sunderland lines. For margins, see Boldon East Junction and Boldon West Junction on LN627. Trains cannot stand on Boldon East Curve or Boldon West Curve. No pathing time or other allowances to be applied between any of these locations		

Green Lane Junction (PTA Boundary)

Note: this location is outwith NR infrastructure. Information included for guidance only

Junction Margins

First Movement	Second Movement	Margin
Pass to Boldon North Junction	Depart towards Tyne Dock	3
Arrive Tyne Dock	Pass Green Lane towards Tyne Dock	3

Notes:

All arriving trains MUST STOP at Stop Board P2 in order to obtain permission from Tyne Dock personnel, to proceed. To be shown as a 2 minute OP stop

Tyne Dock		
Note: this location is outwith NR infrastructure. Information included for guidance only		
Junction Margins		
First Movement	Second Movement	Margin
Pass Green Lane Junction	Depart Tyne Dock	3
Arrive any Tyne Dock Location	Depart any Tyne Dock Location	5
Notes:		
<ul style="list-style-type: none"> • Departures from Tyne Dock should ideally be no closer than 15 minutes apart 		

LN676 PARK LANE JUNCTION TO KING EDWARD BRIDGE SOUTH JUNCTION		
Greensfield Junction		
Junction Margins		
First Movement	Second Movement	Margin
Pass to High Level Bridge Junction	Pass from Park Lane on Greensfield East Line	4
Pass to High Level Bridge Junction	Depart from Greensfield East Line	1½
Pass to Park Lane on Greensfield East Line	Pass from High Level Bridge	3
Pass to Park Lane on Greensfield East Line	Depart from West Curve	2
Restrictions:		
<ul style="list-style-type: none"> • Freights RA6 and above must not be planned to use the curve between Greensfield Junction and High Level Bridge Junction. The above restriction also applies to all movements involving class 67 locomotives • No allowances or pathing time to be applied between High Level Bridge Junction or Park Lane Junction and Greenfields Junction; an 'A' stop must be applied at Greensfield Junction • Maximum length of train which can stand at Greensfield Junction on West Curve is 150m Maximum length of train which can stand at Greensfield Junction on Greensfield East Line is 630m 		

King Edward Bridge East Junction		
Junction Margins		
First Movement	Second Movement	Margin
Pass from KEB South/North	Pass to KEB South or KEB North	2½
Pass from KEB South/North	Depart to KEB South or KEB North	2
Pass to KEB North	Pass from KEB South, coming from Up Carlisle	5*
Pass to KEB North	Pass from KEB South, coming from Down ECML	3½
Pass to KEB North	Depart from Gateshead Chord to Greensfield/Park Lane	2
Pass to KEB South	Pass from KEB North	2½
Pass to KEB South	Depart from South East Curve to Greensfield/Park Lane	2
Arrive from Park Lane Junction/Greensfield Junction #	Pass from KEB South, coming from Up Carlisle	6+
Arrive from Park Lane Junction/Greensfield Junction #	Pass from KEB South, coming from Down ECML	4½
Arrive from Park Lane Junction/Greensfield Junction #	Pass from KEB North	3½
Arrive from Park Lane Junction/Greensfield Junction #	Depart from Gateshead Curve or South East Curve, towards Greensfield Junction	3
*Can be reduced to 3½ minutes provided at least {1} applied between Norwood Junction and King Edward Bridge South Junction		

King Edward Bridge East Junction

+ Can be reduced to 4 minutes provided at least {1} applied between Norwood Junction and King Edward Bridge South Junction

In order to avoid coming to a stand at King Edward Bridge East Junction, (pathing time) can be added between Park Lane Junction and Greensfield Junction (or an 'A' stop added at Greensfield Junction), provided the train length does not exceed 630m

Restrictions:

- Maximum length of train which can stand at King Edward Bridge East Junction on South East Curve is 95m
- Maximum length of train which can stand at King Edward Bridge North Junction on South East Curve is 135m
- Maximum length of train which can stand at King Edward Bridge East Junction on Gateshead Curve is 190m
- Maximum length of train which can stand at King Edward Bridge South Junction on Gateshead Curve is 195m
- Maximum length of train which can stand at Greensfield Junction on Greensfield West line is 200m (if coming from High Level Bridge Junction) or 225m (if coming from Park Lane Junction)
- A down train from Park Lane Junction/Greensfield Junction, coming to a stand at King Edward Bridge East Junction, 'claims' the overlap across the junction. Margins above reflect the resultant timeout
No allowances to be applied between King Edward Bridge South Junction and King Edward Bridge East Junction, or between King Edward Bridge North Junction and King Edward Bridge East Junction in either direction; an 'A' stop should be inserted when required

LN678 DARLINGTON NORTH JUNCTION TO EASTGATE

Heighington

Junction Margins

First Movement	Second Movement	Margin
Arrive from Darlington	Depart to Darlington	2

Shildon

Junction Margins

First Movement	Second Movement	Margin
Arrive from Bishop Auckland	Arrive from Darlington	3

Bishop Auckland/Bishop Auckland West

Minimum Turnround	5. DMU. There must not be two consecutive 5 minute turnrounds, and the total of any two consecutive turnrounds must equal 15 minutes. These values may be reduced if sufficient pathing time is included in the schedule approaching Bishop Auckland or Darlington
-------------------	--

LN682 KING EDWARD BRIDGE SOUTH JUNCTION TO PETERIL BRIDGE JUNCTION

King Edward Bridge South Junction

Refer LN600

Norwood Junction		
Junction Margins		
First Movement	Second Movement	Margin
Pass from Newcastle	Pass to Tyne Yard	3
Pass to Tyne Yard	Depart/Pass from Newcastle	3
Pass from Tyne Yard	Pass to Tyne Yard	4

Swalwell Junction		
Junction Margins		
First Movement	Second Movement	Margin
Depart to Up (after reversal)	Pass Metrocentre on Down	3
Depart to Up (after reversal)	Depart Metrocentre on Down	1½
Pass/arrive Metrocentre on Up	Depart from Down (after reversal)	1

Hexham		
Dwell Time		
DMU	1	
Adjustments to Sectional Running Times		
Movement Up	Reason	Value
Depart to Newcastle from Down platform	Differential junction speed	½
Junction Margins		
First Movement	Second Movement	Margin
Up Depart to Up Main (including signal H55) from Down platform	Down Arrive	4½
Depart to Middle Road from platform	Down Arrive	4
Up Depart to Up Main (including signal H55) from Down platform	Down pass	4
Depart to Middle Road from platform	Down pass	3
Down Pass / Depart	Depart Middle Road to Platform	2½
Up pass / depart Up platform	Shunt from Down platform to H55 on Up main	3
Minimum Turnround	5 Same platform arriving and departing in passenger service 3 Down arrive, depart as class 5 3 Class 5 at signal H55 3 Down empty arrive Up platform, depart in passenger service	
Shunts	Shunts at Hexham to be timed.	

Haltwhistle
Restrictions:
<ul style="list-style-type: none"> A train using the crossover west of Haltwhistle will prevent a Down train arriving or standing in the Down platform due to signalling overlap
Note:
<ul style="list-style-type: none"> Signalling in the Up direction will allow a train to proceed past Haltwhistle to signal HW102, whilst waiting for a previous train to clear the section. A further train can pass Low Row 2 minutes after the train passes Haltwhistle

LN694 BENTON NORTH JUNCTION TO MORPETH NORTH JUNCTION VIA BEDLINGTON

Newsham

Junction Margins		
First Movement	Second Movement	Margin
Pass/arrive from Benton	Depart to Benton	2
Pass to Benton	Depart to Bedlington	Same time*
Arrive from Bedlington	Depart to Bedlington	Same time*
Arrive from Bedlington	Arrive from Benton	4
Depart to Bedlington	Pass/arrive from Benton	6

Bedlington North

Adjustments to Sectional Running Times		
Movement Down	Reason	Value
Up train entering Furnaceway Sidings After Bedlington North	Approach control	2
Movement Up	Reason	Value
Up train from West Sleekburn Junction	Differential junction speed	½

Junction Margins		
First Movement	Second Movement	Margin
Pass to West Sleekburn	Pass from Morpeth	4
Pass from Morpeth	Pass to Morpeth	4
Pass from Morpeth	Pass to West Sleekburn	4
Pass/arrive from Newsham	Pass/depart from West Sleekburn	Same time*
Arrive from Newsham	Pass/depart from Hepscoth	Same time*
* The section from Bedlington South to Newsham is to be treated as a single line pending viaduct strengthening.		

Hepscoth Junction

Junction Margins		
First Movement	Second Movement	Margin
Pass to Morpeth	Pass from Morpeth North Junc	4
Pass to Morpeth	Depart Up Loop	2
Pass to Morpeth North	Pass from Morpeth	4
Arrive Up Loop	Arrive Down Loop	3
Arrive up Loop	Depart Down Loop	1

LN702 BEDLINGTON NORTH TO LYNEMOUTH ALCAN

West Sleekburn Junction

Adjustments to Sectional Running Times

Movement Down	Reason	Value
Down train towards Winning Approaching West Sleekburn	Slow speed junction	1

Junction Margins

First Movement	Second Movement	Margin
Pass to Winning Junction	Pass from Marchey's House	4
Pass from Marchey's House	Pass to Winning Junction	4

Marchey's House

Junction Margins

First Movement	Second Movement	Margin
Pass to West Sleekburn Junction	Pass from Winning Junction	4
Pass to Winning Junction	Pass to West Sleekburn Junction	4
Pass to Winning Junction	Pass from Winning Junction	4
Pass from Ashington	Pass to West Sleekburn Junction	5
Pass from Ashington	Depart to Ashington	2

LN706 WEST SLEEBURN JUNCTION TO NORTH BLYTH

Winning

Junction Margins

First Movement	Second Movement	Margin
Pass to Marchey's House	Pass from West Sleekburn	6
Pass from West Sleekburn	Pass to Marchey's House	4

Freemans

Junction Margins

First Movement	Second Movement	Margin
Pass to Winning	Arrive from Winning (for token exchange)	5½*
Arrive Battleship Wharf	Depart/pass to North Blyth	25
Arrive Blyth Alcan	Depart/pass to North Blyth	35
Pass from North Blyth	Depart Battleship Wharf or Alcan	15

*May be reduced to 4 if {1} inserted approaching Freemans

Operating Restrictions

- Trains going to North Blyth must have a 30s TW stop; trains coming from North Blyth do not stop, but are subject to a 10mph speed restriction
- Trains between Freemans and North Blyth must be in possession of the key token. When two consecutive same direction moves are planned, the margins above allow the transfer of the said token by road

LN736 CLEETHORPES TO NUNNERY MAIN LINE JUNCTION VIA RETFORD

General note

A light engine must run between Wrawby Junction and Gainsborough Trent Junction, and Gainsborough Trent Junction and Wrawby Junction via Brigg for signalling integrity purposes before a passenger train runs, when no trains have passed over this route for six days or more.

Cleethorpes

Junction Margins

First Movement	Second Movement	Margin
Arrive from Grimsby	Depart to Grimsby	1

Minimum Turnround

8 Barton services
10 Lincoln services
15 Doncaster/Newark and beyond

Train Watering Points

Available at the station

New Clee

Dwell Time

Request stop only	No dwell allowance
-------------------	--------------------

Grimsby Docks

Dwell Time

Cleethorpes – Barton on Humber services	½
---	---

Grimsby Docks Loop

Junction Margins

First Movement	Second Movement	Margin
Arrive Grimsby Town from Cleethorpes	Depart Loop for Cleethorpes	Same Time
Arrive Loop from Grimsby Town	Depart Cleethorpes (non stop)	3 before Up train arrives in Loop
Arrive Loop from Grimsby Town	Depart Cleethorpes (stopping)	Depart Grimsby Docks 3 after Up train arrives in Loop

Grimsby Town		
Dwell Time		
Barton services	1	
All other services	1½	
Junction Margins		
First Movement	Second Movement	Margin
Arrive in Bay	Arrive from Cleethorpes	3
Arrive from Cleethorpes	Arrive in Bay	3
Arrive in Bay	Depart to Habrough	1
Arrive from Cleethorpes	Depart to Cleethorpes	1
Minimum Turnround		
	8 Barton services	
	10 Lincoln services	
	15 Doncaster/Newark and beyond	

Marsh Junction		
Junction Margins		
First Movement	Second Movement	Margin
Pass to Grimsby	Pass from Branch	3
Pass from Branch	Pass to Grimsby (non stop)	5
Pass from Branch	Pass to Grimsby (stopping Great Coates)	3

Great Coates		
Dwell Time		
Cleethorpes – Barton on Humber services	½	

Healing		
Dwell Time		
Cleethorpes – Barton on Humber services	½	

Stallingborough		
Dwell Time		
Cleethorpes – Barton on Humber services	½	

Habrough		
Junction Margins		
First Movement	Second Movement	Margin
Arrive from Ulceby	Depart to Ulceby	At same time

Habrough		
Arrive/pass from Brocklesby	Depart to Ulceby	At same time
Depart to Ulceby	Arrive/pass from Brocklesby	4

Brocklesby		
Junction Margins		
First Movement	Second Movement	Margin
Pass to Cleethorpes	Pass to Doncaster/Retford	Pass Ulceby 1 after train to Cleethorpes passes Brocklesby
Pass from Ulceby	Pass to Cleethorpes	4
Pass from Ulceby to DGL	Pass from Cleethorpes	4

Wrawby Junction		
Adjustments to Sectional Running Times		
Movement Up	Reason	Value
Train to Up Slow Line from Scunthorpe/Brigg/ Lincoln. Approaching Wrawby Jn.	Approach Control	2
Junction Margins		
First Movement	Second Movement	Margin
Pass from Newark/Retford	Pass to Doncaster/Retford	3
Pass to Doncaster/Retford	Pass from Newark/Retford	4

Brigg		
Junction Margins		
First Movement	Second Movement	Margin
Arrive from Wrawby	Depart to Wrawby	1

Kirton Lime Sidings		
Junction Margins		
First Movement	Second Movement	Margin
Pass from Northorpe	Pass to Northorpe	3

Northorpe SB		
Junction Margins		
First Movement	Second Movement	Margin
Arrive Loop from either direction	Pass ML	6*

* May be reduced to 4 minutes if second train has 2 minutes pathing approaching Northorpe SB

Gainsborough Central		
Junction Margins		
First Movement	Second Movement	Margin
Arrive from Single line	Depart to Single line	Same time

Gainsborough Trent Junctions								
Junction Margins								
1 st move →	Retford to Wrawby Jn	Retford to Lincoln	Don to Wrawby Jn	Don to Lincoln	Lincoln to Don	Lincoln to Retford	Wrawby Jn to Don	Wrawby Jn to Retford
2 nd move ↓								
Retford to Wrawby Jn	–	5	4	3	3	No conflict	3	No conflict
Retford to Lincoln	5	–	4	–	3	No conflict	4	4
Don to Wrawby Jn	4	4	–	5	No conflict	No conflict	No conflict	No conflict
Don to Lincoln	3	–	5	–	No conflict	No conflict	3	3
Lincoln to Doncaster	3	3	No conflict	No conflict	–	–	5	4
Lincoln to Retford	No conflict	No conflict	No conflict	No conflict	–	–	3	5
Wrawby Jn to Don	3	4	No conflict	4	5	4	–	4
Wrawby Jn to Retford	No conflict	4	No conflict	4	4	5	4	–

West Burton East Junction		
Junction Margins		
First Movement	Second Movement	Margin
Pass from West Burton PS	Pass to Clarborough Junction	4
Pass to Clarborough Junction	Depart Pass from West Burton PS	3

West Burton West Junction		
Junction Margins		
First Movement	Second Movement	Margin
Pass to West Burton PS	Pass from Junction	4
Pass from Trent Junction	Pass to West Burton PS	3

Clarborough Junction		
Junction Margins		
First Movement	Second Movement	Margin
Pass to Cottam PS	Pass from West Burton SB	4
Pass from West Burton SB	Pass to Cottam PS	3

Retford Low Level		
Dwell Time		
All	1	
Junction Margins		
First Movement	Second Movement	Margin
Arrive siding	Pass Thrumpton West to Worksop	Same time
Pass Thrumpton West to Worksop	Arrive siding	8
Minimum turnaround	10 Only from Worksop direction via UGL from Low Level Up Platform to Low Level Down Platform. Not permitted from Gainsborough direction.	

Manton Wood		
Junction Margins		
First Movement	Second Movement	Margin
Arrive reception from Worksop	Pass to Worksop	4
Pass Down Main	Arrive Up reception	3

Worksop		
Adjustments to Sectional Running Times		
Movement Down	Reason	Value
Departing Down platform to Mansfield. Approaching Shireoaks East Jn.	Differential junction speed	½
Departing Up platform to Mansfield. Approaching Shireoaks East Jn.	Differential junction speed	1
Departing Up platform to Sheffield. Approaching Shireoaks East Jn.	Differential junction speed	½
Departing from Worksop Up Reception	Acceleration	3
Pass from Retford to Down Reception Line 1	Approach Control, approaching Worksop	2
Pass from Retford to Down Reception Line 2	Approach Control and need for driver to obtain permission from signaller to pass stop board. Approaching Worksop	4 (can be reduced to 2 if train less than 21 HTAs)
Movement Up	Reason	Value
Terminating services with extended dwell, (greater than 1½ minutes)	Approach Control	1
Dwell Time		
All	1	
Junction Margins		
First Movement	Second Movement	Margin
Depart Up platform to Shireoaks East Junction	Arrive Up platform form West	4
*May be reduced by 1" if {1} applied approaching Worksop		

Worksop	
Minimum Turnround	6 Same platform for trains from Nottingham or Sheffield
	10 Replatform for trains from Nottingham or Sheffield. If replatforming is required, ECS can only be shunted from Worksop Up platform to Worksop Down platform at Worksop East crossover for trains from Sheffield or Nottingham. For trains from the Gainsborough direction, the ECS can only be shunted from Worksop Down platform to Worksop Up platform via Worksop West crossover.

Shireoaks East Junction		
Adjustments to Sectional Running Times		
Movement Down	Reason	Value
Train from Worksop Yard after Shireoaks East Junction	Differential junction speed	1
Trains not stopping at Worksop going towards Woodend Junction Approaching Shireoaks East Jn	Differential junction speed and approach control	1
Passenger/Light Engines from a stop at Worksop, going towards Woodend Junction. Approaching Shireoaks East Junction	Differential junction speed and approach control	½
Movement Up	Reason	Value
Train from Mansfield to Worksop Approaching Worksop	Differential junction speed	½ (1 for above 1400t/TR85)
Train to Worksop Yard Approaching Shireoaks East Jn	Differential junction speed	1
Junction Margins		
First Movement	Second Movement	Margin
Pass from Woodend Junction	Pass to Shireoaks station	3
Pass to Shireoaks station	Pass from Woodend Junction	3
Restriction:		
<ul style="list-style-type: none"> No allowances to be applied between Shireoaks East Junction and either Yard and/or Reception lines in either direction Up Reception Lines 1 and 2 can accommodate loco + 26 HTA wagons Worksop Yard manager can be contacted on 01302-575203 		

Shireoaks Station (West Junction)		
Junction Margins: Times based on Shireoaks station		
First Movement	Second Movement	Margin
Pass to Woodend Junction	Arrive/pass from Shireoaks East Junction	5
Pass from Shireoaks East Junction	Pass to Woodend Junction	3
Depart Shireoaks station to Sheffield	Pass to Woodend Junction	3
Pass from Woodend Junction	Pass to Woodend Junction	4

Brancliffe East Junction		
Adjustments to Sectional Running Times		
Movement Down	Reason	Value
Train to Maltby Between Shireoaks & Brancliffe East Jn.	Approach Control	1
Movement Up	Reason	Value
Train from Maltby Between Brancliffe East Jn. & Shireoaks	Differential junction speed	1
Junction Margins		
First Movement	Second Movement	Margin
Pass to Dinnington	Pass Kiveton Park (not stopping)	2
Pass to Dinnington	Up depart Kiverton Park	3*
Pass from Kiveton Park	Pass to Dinnington	3
Pass from Kiveton Park	Depart to Dinnington	2
*May be reduced to 2 minutes if (1) applied after Kiverton Park due to having cautionary aspect		
Restrictions:		
<ul style="list-style-type: none"> A train from Woodend, going to South Yorkshire Joint, or vice versa, must be allowed a minimum total of 3½ minutes, SRT and { }, between Shireoaks Station and Brancliffe East Junction, and vice versa, due to combination of line speeds and Approach Control signalling An up train from Kiveton Park must pass Brancliffe Junction at least 1 minute before a following train can arrive or pass Kiveton Park. 		

Woodhouse Junction		
Junction Margins		
First Movement	Second Movement	Margin
Pass to Beighton Junction from Woodburn	Pass from Kiveton Park	4
Pass to Beighton Junction from Woodburn	Depart Sidings to Kiveton Park (see also Restrictions) Clear 10s(MU) 1m(LH) reset 30s move 30s	1½ after MU 2½ after LH
Pass from Kiveton Park	Pass to Beighton Junction	4
Arrive Sidings	Depart Sidings	2

Woodburn Junction		
Junction Margins		
First Movement	Second Movement	Margin
Pass from Tinsley East Junction	Pass to Tinsley East Junction	4
Pass from Tinsley East Junction	Pass to Woodhouse Junction	4
Pass to Woodhouse Junction	Pass from Tinsley East Junction	3
Pass to Deepcar	Pass from Tinsley East Jn / Nunnery ML Jn	4
Pass from Woodhouse Jn/Tinsley East Jn	Pass to Deepcar	3
*+1 if second train LH		
Restriction:		
<ul style="list-style-type: none"> Tokenless One Train Working on Stocksbridge Line EMT class 5s turn back on up Worksop, east of Woodburn Junction 		

LN740 GRIMSBY MARSH WEST JUNCTION TO HUMBER ROAD JUNCTION	
Great Coates No1 Signal Box	
Operating Stop	All trains to/from Grimsby Union Dock Branch must have a 2 minute 'OP' stop to collect /return the staff used for OT(S) working

Pyewipe Road Signal Box	
Operating Stop	All trains to/from Immingam East Junction must have a 2 minute 'OP' stop for token exchange purposes

Humber Road Junction			
Adjustment to Sectional Running times			
Movement Up	Reason	Value	
Up services to the N.C.B Coal Terminal or Reception Sidings (including RR1,RR7 and ESL)	Approach Control	1	

The junction margins for Humber Road Jn are to be replaced with those detailed in the following matrix:

Table 1: Junction Margin Matrix for IMNGHRJ Humber Road Junction (NB: *the matrix continues on the next page*)

There is one train working at the NCB 1, RR1, and RR7 coal loading points

At Reception Sidings, roads 3, 4 and 5 are available for trains arriving at the yard itself. RR1 consists of Roads 1 and 2, and RR7 consists of Roads 6 and 7

ESL is a bi-directionally worked siding line with stop boards. Trains can exit into Immingham Sorting Sidings at the eastern end of ESL

Humber Road Junction							196 Routes Detailed in the Matrix								
2nd Move →	Pass Up Main to Up Killingholme	Pass Up Main to NCB Arrivals	Pass UM to Reception Sidings (via Arrival/Dep. Line)	Pass UM to Reception Road 7 (via Arrival/Dep. Line)	Pass UM to Reception Road 1 (via Arrival/Dep. Line)	Pass UM to ESL	Pass UM to Up Grimsby	Pass DM from Down Killingholme	Pass DM from NCB	Pass DM from Reception Sidings (via Arrival/Dep. Line)	Pass DM from Reception Road 7 (via Arrival/Dep. Line)	Pass DM from Reception Road 1 (via Arrival/Dep. Line)	Pass DM from ESL	Pass DM from Down Grimsby	
1st Move ↓															
Pass UM to Up Killingholme	H	H	H	H	H	H	H	P	P	P	P	P	P	P	
Pass UM to NCB Arrivals	7½*	n/a	H	H	H	H	7½*	7½	n/a	P	P	P	P	P	
Pass UM to Reception Sidings (via Arrival/Dep. Line)	8*	H	10½*	10½*	10½*	10½*	12½*	8	10½	21†	25½†	25½†	20†	11½	
Pass UM to Reception Road 7 (via Arrival/Dep. Line)	8*	H	10½*	n/a	10½*	10½*	12½*	8	10½	21†	n/a	25½†	20†	11½	
Pass UM to Reception Road 1 (via Arrival/Dep. Line)	8*	H	10½*	10½*	n/a	10½*	12½*	8	10½	21†	25½†	n/a	20†	11½	
Pass UM to ESL	8*	H	9½*	9½*	9½*	9½*	11½*	8	10½	16½†	21†	21†	n/a	10½	
Pass UM to Up Grimsby	H	H	H	H	H	H	H	5	7½	5	9½	9½	5	4	

Pass DM from Down Killingholme	P	3	3	3	3	3	5	H	10*	H	H	H	H	H
Pass DM from NCB	P	3	3	3	3	3	5	H	n/a	H	H	H	H	H
Pass DM from Reception Sidings (via Arrival/Dep. Line)	P	P	3	3	3	3	5	H	10*	H	H	H	H	H
Pass DM from Reception Road 7 (via Arrival/Dep. Line)	P	P	3	3	3	3	5	H	10*	H	n/a	H	H	H
Pass DM from Reception Road 1 (via Arrival/Dep. Line)	P	P	3	3	3	3	5	H	10*	H	H	n/a	H	H
Pass DM from ESL	P	P	3	3	3	3	5	H	10*	H	H	H	H	H
Pass DM from Down Grimsby	P	P	3	3	3	3	5	H	10*	H	H	H	H	H
	Pass Up Main to Up Killingholme	Pass Up Main to NCB Arrivals	Pass UM to Reception Sidings (via Arrival/Dep. Line)	Pass UM to Reception Road 7 (via Arrival/Dep. Line)	Pass UM to Reception Road 1 (via Arrival/Dep. Line)	Pass UM to ESL	Pass UM to Up Grimsby	Pass DM from Down Killingholme	Pass DM from NCB	Pass DM from Reception Sidings (via Arrival/Dep. Line)	Pass DM from Reception Road 7 (via Arrival/Dep. Line)	Pass DM from Reception Road 1 (via Arrival/Dep. Line)	Pass DM from ESL	Pass DM from Down Grimsby
<p>P = Parallel move; H = a following move on headway (6 minutes for LN740/742); —* = a following move in the same direction with differential value detailed; n/a = Move not applicable, one train working in terminal. † = the conflict occurs within Reception Sidings yard. The stated margin describes the pass time at Humber Road Jn for a 2nd move departure from the yard immediately following a 1st move arrival.</p>														

Immingham West Junction								196 Routes Detailed in the Matrix						
2nd Move →	Pass on Up K'holme to IBT Ore Line	Pass on Up K'holme to IBT Coal Pad 1	Pass on Up K'holme to IBT Coal Pad 2	Pass on Up K'holme to HIT No. 1 or No.2 Arrival/Departure	Pass on Up K'holme to Western Jetty Arrival Line (for Simon Storage West) †	Pass on Up K'holme to Henders on Quay	Pass on Up K'holme to Mineral Quay	Pass on DN K'holme from Mineral Quay	Pass on DN K'holme from Henders on Quay	Pass on DN K'holme from Western Jetty Departure Line (from Simon Storage West)	Pass on DN K'holme from HIT No.1 or No.2 Arrival/Departure Line	Pass on DN K'holme from IBT Coal Pad 2	Pass on DN K'holme from IBT Coal Pad 1	Pass on DN K'holme from IBT Ore Line
1st Move ↓														
Pass on Up K'holme to IBT Ore Line	n/a	H	H	H	H	H	H	P	P	P	P	9	9	n/a
Pass on Up K'holme to IBT Coal Pad 1	H	n/a	H	H	H	H	H	P	P	P	P	9	n/a	9
Pass on Up K'holme to IBT Coal Pad 2	H	H	n/a	H	H	H	H	P	P	P	P	n/a	9	9
Pass on Up K'holme to HIT No. 1 or No.2 Arrival/Departure	6½*	6½*	6½*	n/a	H	H	H	8	8	8	7	9	9	9
Pass on Up K'holme to Western Jetty Arrival Line (for Simon Storage West) †	6½*	6½*	6½*	H	n/a	H	H	8	10½	n/a	7	9	9	9
Pass on Up K'holme to Henderson Quay	6½*	6½*	6½*	H	H	n/a	H	8	n/a	12½	7	9	9	9
Pass on Up K'holme to Mineral Quay	6½*	6½*	6½*	H	H	H	9½*	14½	8	8	7	9	9	9

Pass on DN K'holme from Mineral Quay	P	P	P	3	3	3	3	8½*	6½*	6½*	H	H	H	H
Pass on DN K'holme from Henderson Quay	P	P	P	3	3	3	3	6½*	n/a	9½*	H	H	H	H
Pass on DN K'holme from Western Jetty Dep. Line (from Simon Storage West)	P	P	P	3	3	3	3	6½*	9½*	n/a	H	H	H	H
Pass on DN K'holme from HIT No.1 or No.2 Arrival/Departure	P	P	P	3	3	3	3	6½*	6½*	6½*	n/a	H	H	H
Pass on DN K'holme from IBT Coal Pad 2	2½	2½	2½	2½	2½	2½	2½	H	H	H	H	n/a	H	H
Pass on DN K'holme from IBT Coal Pad 1	2½	2½	2½	2½	2½	2½	2½	H	H	H	H	H	n/a	H
Pass on DN K'holme from IBT Ore Line	2½	2½	2½	2½	2½	2½	2½	H	H	H	H	H	H	n/a
	Pass on Up K'holme to IBT Ore Line	Pass on Up K'holme to IBT Coal Pad 1	Pass on Up K'holme to IBT Coal Pad 2	Pass on Up K'holme to HIT No. 1 or No.2 Arrival/Departure	Pass on Up K'holme to Western Jetty Arrival Line (for Simon Storage West) †	Pass on Up K'holme to Henderson Quay	Pass on Up K'holme to Mineral Quay	Pass on DN K'holme from Mineral Quay	Pass on DN K'holme from Henderson Quay	Pass on DN K'holme from Western Jetty Departure Line (from Simon Storage West)	Pass on DN K'holme from HIT No.1 or No.2 Arrival/Departure Line	Pass on DN K'holme from IBT Coal Pad 2	Pass on DN K'holme from IBT Coal Pad 1	Pass on DN K'holme from IBT Ore Line
P = Parallel move; H = a following move on headway (6 minutes for LN740/742); —* = a following move in the same direction with differential value detailed; n/a = Move not applicable, one train working in terminal; †= With the exception of LD moves, all trains destined for Simon Storage West are required to perform a run round on the Western Jetty Arrivals line and propel into the terminal. This requires the use of the Down Killingholme Line.														

LN742 KILLINGHOLME TO BROCKLESBY JUNCTION		
Immingham West Junction (junction margins are detailed above in the matrix)		
Adjustment to Sectional Running times		
Movement Up	Reason	Value
Up services to the H.I.T. Arrival/Departure Line No.1 or No.2, Western Jetty Arrival Line, Henderson Quay or Mineral Quay	Approach Control	½
Up services to the I.B.T. Ore Terminal, Coal Pad 1 or Coal Pad 2	Approach Control	1

Ulceby		
Dwell Time		
All		½
Junction Margins		
First Movement	Second Movement	Margin
Depart to Barton	Arrive from Barton	4
Depart to Barton	Pass from Immingham or Brocklesby	4
Pass from Immingham	Arrive from Habrough/Barton	4
Pass from Brocklesby	Depart to Barton	3
Pass from Brocklesby	Arrive from Barton	4

LN744 ULCEBY NORTH JUNCTION TO BARTON ON HUMBER		
Thornton Abbey		
Dwell Time		
All		½
All trains in the down direction must come to a stand to wait for the Drivers White Lights for Barton Road Level Crossing		

Goxhill		
Dwell Time		
All		½

New Holland		
Dwell Time		
All		½

Barrow Haven		
Dwell Time		
All		½

Barton on Humber	
Minimum Turnround	5

LN752 WRABY JUNCTION TO MARSHGATE JUNCTION	
Wrawby Junction	
Refer to LN736	

Foreign Ore Branch Junction		
Junction Margins		
First Movement	Second Movement	Margin
Pass from Branch	Down train pass Appleby	2
Down train pass Appleby	Pass from Branch	6
Pass from Branch	Re-occupy Branch	5

North Lincoln Junction		
Junction Margins		
First Movement	Second Movement	Margin
Pass from GL	Pass/arr Scunthorpe from Wrawby Junction	6
Pass/arr Scunthorpe from Wrawby Junction	Pass from GL	Same time

Trent Junction		
Junction Margins		
First Movement	Second Movement	Margin
Pass to Up side	Before Up passenger departs Scunthorpe	2
Pass to Up side	Before Up passes Scunthorpe	3
Pass from Down side	Before down pass/arr Scunthorpe	5
Pass from Trent FD	Pass to Trent FD	5

Scunthorpe		
Dwell Time		
All	1	
Junction Margins		
First Movement	Second Movement	Margin
Depart Platform 1 to Doncaster	Arr/pass Platform 1 from Doncaster	4
Pass to E line	Depart from Scunthorpe	3
Depart from Scunthorpe	Pass to E line	4
Train departing from or passing through Up or Down platforms	Departure to Doncaster from Plat. 2 (Down) of train from the East end (Up) bay (incls. Shunt moves)	7
Minimum Turnround	5 (10 if replatformed) from Doncaster or Cleethorpes. 10 from beyond Doncaster	
If the turnround is substantially more than 10 minutes, then the train must be replatformed to the East End Bay		

Gunhouse Loop		
Junction Margins		
First Movement	Second Movement	Margin
Arrive Loop	Stopping depart Althorpe	4
Arrive Loop	Non-stop arrives Scunthorpe	8
Stopping service depart Althorpe	Depart Loop	3
Depart Loop	Non-stop arrives Scunthorpe	Same time

Thorne Junction		
Adjustments to Sectional Running Times		
Movement Up	Reason	Value
Train from Up Slow Line. Approaching Crowle	Differential Junction Speed	1
Junction Margins		
First Movement	Second Movement	Margin
Pass to Hull	Pass from Hull	4
Pass from Hull	Pass to Hull/Cleethorpes	4*
Pass to Cleethorpes	Pass from Hull	3
Pass from Cleethorpes	Pass from Hull if calling at Hatfield and Stainforth	3
* May be reduced to 3 if the service calls at Hatfield and Stainforth		

Hatfield Colliery		
Operating Restriction		
Only one train can be accommodated in the colliery at once. Trains can depart the colliery in the Down direction on the Up Slow Line or the Down Fast Line		
Junction Margins		
First Movement	Second Movement	Margin
Depart Colliery	Pass Hatfield & Stainforth on Up Fast/Up Slow	8
Depart Colliery	Arrive Colliery	20

Hatfield and Stainforth		
Adjustments to Sectional Running Times		
Movement Up	Reason	Value
Trains from Applehurst Jn. to Up Slow Line Approaching Thorne Jn	Acceleration	1
Trains from Applehurst Jn. to Up Fast Line Approaching Thorne Jn.	Acceleration	2
Junction Margins		
First Movement	Second Movement	Margin
Pass to Branch	Pass/Arrive from Doncaster	4
Pass/Arrive from Doncaster	Pass to Branch	2½
Pass to Branch	Arrive from Thorne	3

Kirk Sandall Junction		
Junction Margins		
First Movement	Second Movement	Margin
Pass from Branch to SL	Pass from Doncaster ML	*
Pass from Branch	Pass to Doncaster	4
Pass to Doncaster	Pass from Branch	3
Pass from Branch	Pass to Branch	4

* Same time as train passes/departs Doncaster or 1 before a freight train passes Bentley Junction

LN756 SCUNTHORPE TRENT JUNCTION TO ROXBY		
Scunthorpe Roxby Gullet/Dragonby Sidings		
Operating Restriction		
<p>Trains running to/from Roxby Gullet/Dragonby Sidings require to be in possession of a Train Staff issued by North Lincoln Junction. A second train cannot proceed along the branch to Roxby Gullet/Dragonby Sidings until the first train has completed its journey on the branch and the Train Staff is surrendered by the driver and returned to North Lincoln Junction, to be re-issued to the second train. A minimum of 30 minutes for Dragonby services and a minimum of 45 minutes for Roxby Gullet services should be allowed for this to take place before the second train can proceed on the branch.</p> <p>This also applies to trains returning from Roxby Gullet/Dragonby Sidings to North Lincoln Junction.</p>		

LN758 BRANCLIFFE EAST JUNCTION TO KIRK SANDALL JUNCTION		
Dinnington Junction		
Junction Margins		
First Movement	Second Movement	Margin
Pass from Single line	Pass to Single line	6*
Pass from Single line	Depart to Single line	2

* May be reduced to 4 minutes if train has at least an additional 2 minutes in the schedule.

Restrictions		
<p>When services are held at Dinnington Junction, WP607 waiting acceptance onto Single Line towards Maltby services in rear can not pass Brancliffe East Junction towards Maltby if the first train exceeds 420m.</p>		

Maltby Loop		
Junction Margins		
First Movement	Second Movement	Margin
Arrive Loop from either direction	Arrive/Pass from other direction	3
Arrive from Dinnington	Depart to Dinnington	4
Pass from Dinnington	Depart to Dinnington	3
Pass/Arrive from St Catherines Junction	Depart to St Catherines Junction	2

Restrictions		
<p>Physical Loop Lengths: Up Single Line Down (DUSY) - M34 to M35 – 355m Passing Loop/Run Round (DUPL)– M29 to M8 - 418m, M29 to M7 – 524m Services held on Passing Loop/Run Round exceeding 418 metres beyond M8 locks out Arrivals and Departures Line in the Dinnington direction. Arrival/Departures (DUAD) – M25 to M9- 415m Specific lines (DUSY, DUPL and DUAD) to be allocated to match required train lengths as above.</p>		

St Catherines Junction Loop		
Junction Margins		
First Movement	Second Movement	Margin
Arrive/Pass from Maltby	Depart to Maltby	2
All other conflicts		3
Restrictions		
Physical Loop Lengths:		
Up/Down St Catherines Curve - D 220 to D227 – 499m		
Up/Down South Yorkshire – D218 to D225 – 499m		

LN768 MANSFIELD WOODHOUSE TO SHIREOAKS EAST JUNCTION		
Shirebrook		
Junction Margins		
First Movement	Second Movement	Margin
Pass-from Shirebrook East Junction	Pass to Clipstone Junctions	2
Pass to Clipstone Junctions	Pass from Shirebrook East Junction going to Shirebrook	4

Shirebrook East Junction		
Junction Margins		
First Movement	Second Movement	Margin
Pass to Shirebrook Junction	Pass from Clipstone Junctions	4
Pass from Clipstone Junctions	Pass to Shirebrook Junction	4
Pass to / from Clipstone Junctions	Pass from Clipstone Junctions	4
All conflicting moves		4

Langwith Whaley-Thorns	
Dwell Time	
All	1 08.00 – 18.00 EWD

Creswell	
Dwell Time	
All	1 08.00 – 18.00 EWD

Whitwell	
Dwell Time	
All	1 08.00 – 18.00 EWD

Woodend Junction		
Junction Margins		
First Movement	Second Movement	Margin
Pass from Shirebrook	Pass Shireoaks West Jn to Woodend	7
Pass from Shireoaks West Jn	Pass from Shirebrook	8

LN774 BARROW HILL NORTH JUNCTION TO OXCROFT DISPOSAL POINT		
Hall Lane Junction		
Junction Margins		
First Movement	Second Movement	Margin
Pass to Foxlow Junction	Pass from Barrow Hill North Junction	4
Pass from Barrow Hill North Junction	Pass to Foxlow Junction	4
All margins to/from single lines		4
All conflicting moves		4

Seymour Junction		
Junction Margins		
First Movement	Second Movement	Margin
All conflicting moves		4

LN784 HIGH MARNHAM TO SHIREBROOK EAST JUNCTION		
Boughton Junction		
Junction Margins		
First Movement	Second Movement	Margin
Pass from Single line	Re-occupy Single line	4

Thoresby Colliery Junction		
Junction Margins		
First Movement	Second Movement	Margin
Pass to Ollerton	Depart from Run round sidings	2
Depart Run round sidings towards Clipstone	Pass from Ollerton/arrive Run round	6

Clipstone East Junction		
Junction Margins		
First Movement	Second Movement	Margin
Pass to Clipstone West Junction	Pass from Clipstone South Junction	4
Pass from Clipstone South Junction	Pass to Clipstone West Junction	4

Rufford Junction/Clipstone Colliery Junction		
Junction Margins		
First Movement	Second Movement	Margin
All margins to/from single lines		4

Clipstone West Junction		
Junction Margins		
First Movement	Second Movement	Margin
Pass to Clipstone South Junction	Pass from Clipstone East Junction	5
Pass from Clipstone East Junction	Pass to Clipstone South Junction	3

Warsop Junction		
Junction Margins		
First Movement	Second Movement	Margin
Pass to Shirebrook East Junction	Pass from Shirebrook Junction	4
Pass from Shirebrook Junction	Pass to Shirebrook East Junction	4

LN804 TAPTON JUNCTION GASCOIGNE WOOD JUNCTION VIA SHEFFIELD		
Dronfield		
Dwell Time		
DMU	½	
22X	1½	

Dore South Junction		
Junction Margins		
First Movement	Second Movement	Margin
Pass Dore Station Junction towards Chesterfield, not stopping Dronfield	Pass from Dore West Junction	3
Up depart Dronfield	Pass from Dore West Junction	Same Time
Pass Dore Station Junction to Sheffield, from Chesterfield	Pass from Dore West Junction	1
Pass to/from Dore West Junction	Pass Dore Station Junction to Sheffield, from Chesterfield	5
Pass from Dore West Junction	Pass to Dore West Junction (not stopping Dronfield)	4

Operating/Planning Restriction
<ul style="list-style-type: none"> Owing to restrictive overlaps at signal S48 trains must not be booked to stand at this signal to await the passage of Down trains, as this will prevent movements on the Down Main from Dronfield towards Dore Station Junction. Long trains of more than 325m will also be foul Down Manchester line at Dore West Junction. Owing to restrictive overlaps at signal S53 trains booked to stand at this signal will prevent movements on the Down Manchester from Dore Station Junction towards Totley Tunnel East until the timeout has elapsed. Long trains of more than 325m will also be foul of Down Main at Dore South Junction. Allowances not to exceed 1 minute between Dore South Junction and Dore West Junction in either direction.

Dore Station Junction		
Adjustments to Sectional Running Times		
Westbound Movement	Reason	Value
Train going from Sheffield/Heeley Loop, towards Totley; approaching Dore Station Junction	Reduced junction speed	½ Passenger or Light Engine
Junction Margins		
First Movement	Second Movement	Margin
Passenger or Light Engine pass to Dore West Junction	Pass from Chesterfield	3
Freight pass to Dore West Junction	Pass from Chesterfield	4
Pass from Chesterfield/Dore West Junction	Pass to Dore West Junction from Sheffield	3
Down services pass signal S77, routed DPL to Sheffield station	Down train pass Dore Station Junction towards Sheffield	1
Restriction		
<ul style="list-style-type: none"> For trains stopping at Dore & Totley Station, no allowances to be applied in either direction between the station and Dore Station Junction 		

Heeley Up Passenger Loop		
Junction Margins		
First Movement	Second Movement	Margin
Arrive in Loop	Depart/pass Sheffield	1
Pass Dore Station Junction	Depart Loop	1

Sheffield			
Adjustments to Sectional Running Times			
Movement Up	Reason	Value	
Trains departing from Platforms 1 – 5 Approaching Dore Station Junction	Differential linespeed	½	
Connectional Allowance		7	
Dwell Time			
XC (22x & HST)	2		
TPE	2		
All other services	3 Through 1, 2, 5, 6 and 8		
Minimum Turnround			
To/from London St Pancras	HST 20 ^{\$}	LH	DMU 20
Fuel		60	60
Lincoln, Wakefield, Huddersfield			7*
To/from Hope Valley			10
From beyond Manchester,			15

Sheffield			
Doncaster, Adwick, Huddersfield or Leeds			
East Midlands Trains reversals	7		4
Other not specified above			10*
XC	20 (10 by exception and in agreement with Network Rail)		
* Reductions to be requested through the Operational Planning Project Manager LNE, Network Rail			
\$ Must not be 2 consecutive 20 min turnrounds St Pancras/Sheffield			
Where minimum turnrounds have been increased and shorter turnrounds already apply for some trains in the 2000 timetable, existing values may continue to be used for a similar number of trains. In the event that the service is amended by changes to the overall pattern, the new values will apply.			
Overlap restrictions			
A minimum of 3 minutes should be allowed between the following movements			
Movement		Conflict	
Arrive Platform 1a from South		Arrive Platform 1b from North (and vice versa)	
Arrive Platform 2 from South		Depart Down Station Siding (and vice versa)	
Arrive Platform 2 from North		Arrive Down Station Siding/Platform 1 from South (and vice versa)	
Arrive Platform 6 from North		Arrive/depart Platform 7 (and vice versa)	
Arrive Platform 8 from North		Arrive/depart Platform 7 (and vice versa)	
Junction Margins			
First Movement		Second Movement	Margin
Platform End Conflicts			
First Movement		Second Movement	Margin
Train Arrive		Conflicting movement depart	1
Depart Platform 1 or 1A to the North		Arrive Platform 1A from the South	3 (no restriction if departure is from 1B)
Depart Platform 1 to the North		Arrive platform 1 or 1B from the South	3 2 if departure is from 1B
Depart 1A to the South		Arrive platform 1 from the North	3 (no restriction if departure is from 1B)
Depart 1 to the South		Arrive platform 1 from the North	3 2 if departure is from 1B
Depart Platform 1, 2, 3, 4 or 5 to the North		Arrive Platform 1 or 2 from the North	4
Depart Platform 2 or 5 to the North		Arrive same Platform from the South	4
Depart Platform 3, 4, or 5 to the North		Arrive Platform 3, 4, or 5 from the North	3*
Arrive Platform 1 from the South		Arrive Platform 2 from the North	4
Arrive Platform 2 from the North		Arrive Platform 1 from the South	4
Arrive Platform 2 from the North		Depart Platform 1 to the South	2
Arrive Platform 6 or 8 from the North		Depart Platform 7 to the South	1
Arrive Platform 6 or 8 from the North		Arrive Platform 7 from the South	3
Arrive Platform 7 from the South		Arrive Platform 6 or 8 from the North	3
Arrive Platform 8 from the South		Arrive Platform 6 from the North	4
Depart Platform 1 or 2 to the South		Arrive Platform 1, 2, 2c or 5 from the South	4½
Depart to the South		Arrive Platform 7 or 8 from the South	5
Depart Platforms 2, 5, 6 or 8 to the South		Arrive same Platform from the North	4
Depart Platform 2c or 5 to the South		Arrive Platform 2c or 5 from the South	4½
Depart Platform 7 to the South		Arrive Platform 6 from the North	3

Sheffield		
* 4 via 'A' line when confliction occurs		
Restrictions		
<ul style="list-style-type: none"> North end Bay Platform couplings are preferred to take place in Platform 3 Passenger services cannot arrive on Platform 6 from the South Passenger services cannot depart Platforms 6 or 8 to the North Trains following into the same platform – not called on – 4 from South, 3 from North ECS-services arriving into Platform 6 to be routed via DPL from SHEF77 Services arriving into Platform 7 and 8 to be routed via DPL from SHEF77 		

Nunnery Main Line Junction		
Junction Margins		
First Movement	Second Movement	Margin
Pass UM	Pass to Woodburn Junction	2½
Pass to Woodburn Junction	Pass UM	3

Mill Race Junction		
Junction Margins		
First Movement	Second Movement	Margin
Pass UML to Sheffield	Pass to GL	Same time as Up service passes Nunnery ML Junction
Pass to GL	Pass UML	3 before Up service passes Wincobank Jn/Brightside Junction 4

Brightside Junction		
Junction Margins		
First Movement	Second Movement	Margin
Pass Down ML	Pass from Slow	1 after Down service passes Wincobank Junction
Pass from Slow	Pass Down ML	1½ before Down service passes Nunnery ML Junction
Pass UML	Pass from Slow	½ before Up ML service passes Nunnery ML Jn
Pass from Up/Dn Goods	Pass on Up Main (non-stop)	3½ before Up

Brightside Junction		
		non-stop passes Wincobank Jn.
Pass from Up/Dn Goods	Pass on Up Main (stopping at Meadowhall)	2½ before Up stopping train passes Wincobank Jn.
Pass on Up Main	Pass from Up/Dn Goods	2½ after Up train passes Wincobank Jn.

Wincobank Junction		
Adjustments to Sectional Running Times		
Movement Down	Reason	Value
Non-stop trains to Barnsley	Approach control	1
Junction Margins		
First Movement	Second Movement	Margin
Pass Down Main	Pass from Barnsley	3 non-stop
Pass from Barnsley	Pass Down Main	3

Meadowhall		
Adjustments to Sectional Running Times		
Movement Down	Reason	Value
Trains via Masborough Junction stopping at Meadowhall. Approaching Holmes Junction	Differential junction speed	-½ DMU
Dwell Time		
All	1	
Minimum Turnround		
	5. 4 only from Barnsley	
Junction Margins		
First Movement	Second Movement	Margin
Depart Platforms 1 – 4	Arrive same platform from same direction	3
Depart Platform 4 to Barnsley	Arrive Platform 4 from Barnsley	4
Depart Platform 4 to SL	Arrive Platform 4 from Sheffield	3
Down pass/Arrive Platform 2 from Sheffield	Depart Platform 3 from Barnsley	1

Holmes Junction		
Adjustments to Sectional Running Times		
Movement Up	Reason	Value
Trains via Masborough Junction stopping at Meadowhall. Approaching Meadowhall	Faster approach speed	-½ DMU
Junction Margins		
First Movement	Second Movement	Margin

Holmes Junction		
Pass from Aldwarke Junction	Pass to Rotherham Central	2½
Pass to Rotherham Central	Pass from Aldwarke Junction	3½*
Pass from Rotherham Central	Pass to Rotherham Central	3
Pass to Rotherham Central	Pass Down ML	3½
Pass UML	Pass from Rotherham Central	2½
*May be reduced by ½ minute if second train has at least 1 minute pathing allowance between Aldwarke Junction and Holmes Junction.		

Masborough Junction		
Junction Margins		
First Movement	Second Movement	Margin
Pass from Treeton Junction	Pass to Treeton Junction	4
Pass to Treeton Junction	Pass from Treeton Junction	5
Pass to Holmes Junction	Pass from Treeton Junction	2 after Up service passes Holmes Jn
Pass from Treeton Junction	Pass to Holmes Junction	1 ½ before Up service passes Aldwarke Jn

Aldwarke Junction			
Adjustments to Sectional Running Times			
Movement Down	Reason		Value
Trains from Masborough Junction. Approaching Swinton	Differential junction speed		-1½ 142/150
Trains from Rotherham Central Approaching Swinton	Differential junction speed		1 185/22X 1½ 158
Trains to the Roundwood Chord Approaching Aldwarke Junction	Approach control		1½
Movement Up	Reason		Value
Trains from Roundwood Chord to Masborough Jn Approaching Holmes Junction	Acceleration		1
Junction Margins			
2nd Move →	Pass from Rotherham Central	Pass UML from Swinton	Pass to Thrybergh Junction
1st Move ↓			

Aldwarke Junction			
Pass UML from Swinton	2½		3
Pass from Rotherham Central	No conflict	4	3
Pass to Thrybergh Jn	3	4	
Pass DML from Masborough Jn	2½	No conflict	
Pass from Thrybergh Jn	4	4*	4
*Different routes Trains from Rotherham Central to Roundwood Chord can run via UML and not conflict with train on DML			

Swinton Junction					
Adjustments to Sectional Running Times					
Movement Down		Reason			Value
Trains to Doncaster direction Approaching Swinton Junction		Differential junction speed			1 Freight ½ Cross Country 22X
Movement Up		Reason			Value
Trains from Doncaster direction, Approaching Aldwarke Junction		Acceleration			½ LH/HST/ 22X
Junction Margins					
2 nd move →	Pass from Moorthorpe	Arrive from Moorthorpe	Pass to Doncaster	Depart to Doncaster	Depart to Sheffield from other route
1 st move ↓					
Pass to Doncaster	4	4½	No conflict	No conflict	
Depart to Doncaster	5	5	No conflict	No conflict	
Pass from Moorthorpe	No conflict	No conflict	4	1	2
Arrive from Moorthorpe	No conflict	No conflict	4	1	Simultaneous
Pass from Doncaster	3	Simultaneous	No conflict	No conflict	2

Moorthorpe		
Junction Margins		
First Movement	Second Movement	Margin
Arrive/pass from South Kirkby Junction	Pass to Pontefract Baghill	4
Arrive/pass from South Kirkby Junction	Depart to Pontefract Baghill	1
Depart/pass to Pontefract Baghill	Arrive / Pass from South Kirkby Junction	4
Arrive Down Loop	Arrive/pass Moorthorpe station	5
Arrive Up Loop	Arrive/pass Moorthorpe station	5
Minimum Turnround 5 Arrive loaded from Sheffield before departing ECS to Sheffield		
Restriction. Trains with more than three minutes pathing time between Ferrybridge Junction/Pontefract Baghill and Moorthorpe should instead be timed to have an 'A' stop at Moorthorpe signal L6586. No allowances to be applied between Moorthorpe signal L6586 and Moorthorpe Station/Moorthorpe Goods Loop		

Ferrybridge North Junction		
Junction Margins		
First Movement	Second Movement	Margin
All conflicting moves		4

Milford Junction			
Adjustments to Sectional Running Times			
Movement Down	Reason	Value	
Train Ferrybridge to Church Fenton Approaching Milford Junction	Approach control	1	
Train from Castleford to Gascoigne Wood Approaching Milford Junction	Approach control	2	
Movement Up	Reason	Value	
Trains from Church Fenton to Ferrybridge Approaching Milford Junction	Approach control	1	
Trains from Gascoigne Wood to Castleford Approaching Castleford	Acceleration	1 Passenger 2 Freight	
Trains from Milford West Sdgs or to Castleford/Ferrybridge North Junction After Milford Junction	Acceleration	3 Freight	
Junction Margins			
First Movement	Second Movement	Margin	
All conflicting moves		4	
Planning Restriction			
Any propelling movement into Milford West Sidings must stop to pick up a radio requiring 2 minute OP stop, prior to propelling at Milford Junction.			
Service from Hambleton West		Service from Church Fenton	
Gascoigne Wood Junction arr	xxOP00	Milford Loop arr	xxOP00
Gascoigne Wood Junction dep	xxOP02	Milford Loop dep	xxOP02
Milford Junction arr	xxPRRM08	Milford Junction arr	xxPRRM06
Milford Junction dep	xxPRRM10	Milford Junction dep	xxPRRM08
Milford West Siding arr	xxPR17	Milford West Siding arr	xxPR15

LN806 TAPTON JUNCTION TO MASBOROUGH JUNCTION VIA 'OLD ROAD'		
Barrow Hill South Junction		
Junction Margins		
First Movement	Second Movement	Margin
Pass to Branch	Pass from Beighton Junction	4
Pass from Beighton Junction	Pass to Branch	3

Barrow Hill North Junction		
Junction Margins		
First Movement	Second Movement	Margin
Pass from sidings	Pass from Beighton Junction	4
Pass from Beighton Junction to Chesterfield	Pass from sidings	3

Foxlow Junction		
Junction Margins		
First Movement	Second Movement	Margin
Pass from Branch	Pass to Chesterfield	4
Pass to Chesterfield	Pass from Branch	3

Beighton Junction		
Adjustments to Sectional Running Times		
Movement Down	Reason	Value
Pass from Down Barrow Hill Line to Woodhouse Junction Approaching Beighton Junction	Approach Control	½ Passenger 1 Freight
Movement Up	Reason	Value
Pass from Woodhouse Junction to Up Barrow Hill Line. Approaching Barrow Hill	Acceleration	½ Passenger 1 Freight
Junction Margins		
First Movement	Second Movement	Margin
Pass from Woodhouse Junction	Pass to Treeton Junction	4
Pass to Treeton Junction	Pass from Woodhouse Junction	4

Masborough Sorting Sidings South Junction/Canklow Loop		
Adjustments to Sectional Running Times		
Movement Up	Reason	Value
Train to Canklow Loop or stopping on Up line, before propelling to Freight Depot	Stop at Signal S406 to collect radio then draw slowly forward	3
Junction Margins		
First Movement	Second Movement	Margin
Down pass Treeton Junction heading towards Masborough Junction	Depart FD	4
Down pass Treeton Junction heading towards Masborough Junction	Depart Canklow Loop towards FD	4
Down pass/Arrive Masborough Junction	Depart Canlow Loop towards Masborough Junction	Same time
Up pass Masborough Junction towards Treeton	Depart FD to Treeton	4½
Up pass Masborough Junction towards Treeton	Depart Canklow Loop towards FD or Masborough Junction	4
Depart FD	Depart to FD	5½

Masborough Sorting Sidings South Junction/Canklow Loop		
Depart FD	Pass to FD from Treeton	6½
Depart FD	Down pass Treeton Junction towards Masborough Junction	4
Depart Up Side to FD	Down pass Treeton Junction towards Masborough Junction	3
Depart Up Side to FD or Masborough Junction	Up pass Masborough Junction towards Treeton	4½
Arrive Canklow Loop	Up pass Masborough Junction towards Treeton	1
Arrive Canklow Loop	Depart FD to Treeton	1
Up pass Masborough Junction towards Treeton Junction	Depart FD to Up Side	4½
Up pass Treeton Junction	Up depart Canklow Loop	1

LN808 DORE STATION JUNCTION TO TOTLEY TUNNEL EAST	
Dore & Totley	
Dwell Time	
Class 1	1
Class 2	½

Dore West Junction		
Adjustments to Sectional Running Times		
Movement Down	Reason	Value
Westbound train, having stopped at Dore & Totley station Approaching Totley Tunnel East	Acceleration	½
Westbound train from Dore South Junction Approaching Totley Tunnel East	Acceleration	1½ Passenger or Light Engine ½ Freight
Movement Up	Reason	Value
Trains towards Dore South Junction Approaching Dore West Jn	Approach control	1½ Passenger or Light Engine 2 Freight
Junction Margins		
First Movement	Second Movement	Margin

Dore West Junction		
Pass from Sheffield	Pass to Sheffield or Chesterfield	3
Pass from Sheffield	Depart to Sheffield or Chesterfield	1½
Pass from Chesterfield	Pass or depart to Chesterfield	2½
Pass to Chesterfield	Passenger not calling at Dore or Light Engine pass from Sheffield	4½*
Pass to Chesterfield	Pass from Sheffield having called at Dore	7+
Pass to Chesterfield	Freight pass from Sheffield	6½**
Depart to Chesterfield	Passenger not calling at Dore or Light Engine pass from Sheffield	6***
Depart to Chesterfield	Pass from Sheffield having called at Dore	8½+++
Depart to Chesterfield	Freight pass from Sheffield	8****
Arrive Dore West Junction from Chesterfield	Passenger not calling at Dore or Light Engine pass from Sheffield	5*
Arrive Dore West Junction from Chesterfield	Pass from Sheffield having called at Dore	7½++
Arrive Dore West Junction from Chesterfield	Freight pass from Sheffield	7**
Note: Values for trains having called at Dore include minimum dwell as specified above		
*Margin can be reduced to 3 minutes if an additional {1} is added approaching Dore Station Junction and {½} approaching Dore West Junction		
** Margin can be reduced to 4 minutes if an additional {1} is added approaching Dore Station Junction and {½} approaching Dore West Junction		
*** Margin can be reduced to 5 minutes if an additional {1} is added approaching Dore Station Junction and {½} approaching Dore West Junction		
**** Margin can be reduced to 6 minutes if an additional {1} is added approaching Dore Station Junction and {½} approaching Dore West Junction		
+ Margin can be reduced to 3½ minutes if an additional {1} is added approaching Dore Station Junction		
++ Margin can be reduced to 4½ minutes if an additional {1} is added approaching Dore Station Junction		
+++ Margin can be reduced to 5½ minutes if an additional {1} is added approaching Dore Station Junction		
Operating/Planning Restriction		
<ul style="list-style-type: none"> Owing to restrictive overlaps at signal S48 trains must not be booked to stand at this signal to await the passage of Down trains, as this will prevent movements on the Down Main from Dronfield towards Dore Station Junction. Long trains of more than 325m will also be foul Down Manchester line at Dore West Junction Owing to restrictive overlaps at signal S53 trains booked to stand at this signal will prevent movements on the Down Manchester from Dore Station Junction towards Topley Tunnel East until the timeout has elapsed. Long trains of more than 325m will also be foul of Down Main at Dore South Junction. Allowances not to exceed 1 minute between Dore South Junction and Dore West Junction in either direction. 		

LN826 DONCASTER SOUTH YORKSHIRE JUNCTION TO SWINTON		
St James Junction		
Junction Margins		
First Movement	Second Movement	Margin
Pass to Hexthorpe Junction	Pass to Bridge Junction	5½

Hexthorpe Junction		
Junction Margins		
First Movement	Second Movement	Margin

Hexthorpe Junction		
Pass to Sheffield	Pass to GL	3
Pass to GL	Pass from Doncaster	4
Pass to Doncaster	Pass from Avoiding Line	3
Pass from Avoiding Line	Pass to Doncaster	4

Mexborough		
Adjustments to Sectional Running Times		
Movement Down	Reason	Value
Trains approaching Mexborough towards Thrybergh Jn	Differential junction speed	½ Class 1 & 5
Movement Up	Reason	Value
Trains approaching Hexthorpe Jn from Thrybergh	Acceleration	½ Class 1 & 5
Junction Margins		
First Movement	Second Movement	Margin
Pass to Swinton	Pass from Thrybergh Junction	4
Pass from Thrybergh Junction	Pass to Swinton	4
Pass from Thrybergh Junction	Pass to Thrybergh Junction	4
Pass to Thrybergh Junction	Pass from Thrybergh Junction	5

LN828 MEXBOROUGH JUNCTION TO ALDWARKE JUNCTION VIA KILNHURST		
Thrybergh Junction		
Junction Margins		
First Movement	Second Movement	Margin
Train from Single Line	Train to Single Line	4

LN830 ALDWARKE JUNCTION TO WOODBURN JUNCTION		
Aldwarke UES		
Junction Margins		
First Movement	Second Movement	Margin
Train arrives Aldwarke UES from north	Pass Aldwarke Junction	3
Train arrives Aldwarke UES from south	Pass Aldwarke Junction	4

Parkgate Junction		
Minimum Turnround		
Supertram 3*		
*Reductions to be agreed between the TOC & Operational Planning Project Manager LNE, Network Rail		

Rotherham Central		
Dwell Time		
Supertram	½	
All	1	
Junction Margins		
First Movement	Second Movement	Margin
Arrive from Holmes Junction	Depart to Holmes Junction	1½
Arrive/pass from Woodburn Junction	Depart to Holmes Junction	1
Pass/depart to Holmes Junction	Arrive/pass from Woodburn Junction	4
Supertram Arrive from Parkgate	Supertram depart to Parkgate	1
Operating Restriction Only 1 Supertram between Rotherham Central and Parkgate in either direction at any one time. This is due to the power being drawn from the overhead lines.		

Tinsley East Junction		
Junction Margins		
First Movement	Second Movement	Margin
Pass from Woodburn Junction	Pass to Woodburn Junction/Supertram	4
Down Pass Tinsley East Junction	Pass from Supertram	2½

Tinsley North Junction		
Junction Margins		
First Movement	Second Movement	Margin
Pass to Supertram	Up Pass Tinsley South Junction	3
Down Pass Tinsley East Junction	Pass from Supertram	2½

Parkgate Junction		
Junction Margins		
First Movement	Second Movement	Margin
Up Pass/Dept Rotherham Central	Tram Depart Parkgate	3
Tram Depart Parkgate	Up Depart Rotherham Central	1½
Tram Depart Parkgate	Up Pass Rotherham Central	2

Tinsley South Junction		
OPERATING RESTRICTION		
All trains towards Shepcote Lane Junction must be planned with an "OP" stop of 2 minutes for driver instructions.		

Broughton Lane Junction		
Junction Margins		
First Movement	Second Movement	Margin
Pass to Tinsley Yard	Pass from Tinsley South Junction	4
Pass to Tinsley South Junction	Pass from Tinsley Yard	3
OPERATING RESTRICTION		
All trains towards Shepcote Lane Junction must be planned with an "OP" stop of 2 minutes for driver instructions.		

LN832 DONCASTER BRIDGE JUNCTION TO ST. JAMES JUNCTION
Bridge Junction
Refer to LN150

LN836 DONCASTER MARSHGATE JUNCTION TO NEVILLE HILL EAST JUNCTION
Adwick
Restriction
A terminating train running ECS towards Skellow Junction can only arrive when route is set towards Skellow Junction at Carcroft Junction

Carcroft Junction		
Junction Margins		
First Movement	Second Movement	Margin
Pass to Branch	Pass Up Main line	1 before Up non-stop passes South Kirkby Jn Same time as Up stopping service departs South Elmsall
Pass Up Main	Arrive Adwick from Doncaster, if terminating and shunting via Carcroft Junction	2½ after non-stop passes Adwick 1 after up stopping train departs Adwick
Pass to Branch	Pass Down Main	Same time as Class 1 stopping service depart Doncaster 1 minute before Class 1 non-stop departs Doncaster
Pass Up Main	Arrive Adwick from Branch	2½ after non-stop passes Adwick
Pass to Branch	Pass from Branch (and vice versa)	4 (Single Lead)

Adwick Junction		
Junction Margins		
First Movement	Second Movement	Margin
Pass Up Main	Pass from Branch	3
Pass from Branch	Pass Up Main	4
Pass to/from Branch	Pass to/from Branch (single lead)	4

South Kirkby Junction		
Adjustments to Sectional Running Times		
Movement Down	Reason	Value
Trains from Moorthorpe Approaching Hare Park	Acceleration	1 except 22X and Freight Classes 6/7/8
Trains from Moorthorpe that are passing South Kirkby and stopping at Fitzwilliam	Differential Junction Speed	½
Trains from Doncaster	Differential junction speed	-½ 224X
Movement Up	Reason	Value
Trains to Moorthorpe	Approach-release Differential junction speed	½ HST
Trains to Doncaster	Differential junction speed	-1 22X
Junction Margins		
First Movement	Second Movement	Margin
Pass Down Main	Pass to Branch	3
Pass to Branch	Pass Down Main	4 Passenger 5 Freight

Hemsworth Loop		
Junction Margins		
First Movement	Second Movement	Margin
Arrive in Down Loop	Pass Down Main	Arrive 1 before Down Passngr passes South Kirkby Jn (frm Moorthorpe). Arrive 2 before Down Passngr passes South Kirkby Jn (frm Doncaster).
Pass Down Main	Depart Down Loop	Depart 1 before Down non-stop Passngr train passes Hare Park Junction. Depart 1 after Down stopping Passenger departs Fitzwilliam.

Hemsworth Loop		
Arrive in Up Loop	Pass Up Main	Arrive Up Loop 1½ before Up Passngr passes Hare Park Jn. Arrive Up Loop 3 before Up stopping Passngr departs Fitzwilliam.
Pass Up Main	Depart Up Loop	Depart same time as Up Passngr passes South Kirkby Jn

Hare Park Junction		
Adjustments to Sectional Running Times		
Movement Down	Reason	Value
Trains to Crofton West Junction – Approaching Hare Park	Approach Control	1
Movement Up	Reason	Value
Passenger trains from Crofton West Junction Approaching South Kirkby	Acceleration Hare Park – South Kirkby	1
Junction Margins		
First Movement	Second Movement	Margin
Pass Up Main	Pass to Branch	3
Pass to Branch	Pass Up Main	4
Pass Up Main	Pass from Branch	3

Wakefield Westgate		
Connectional Allowance	7	
Dwell Time		
EMU/DMU	1	
LH/HST	1½	
Junction Margins		
First Movement	Second Movement	Margin

Wakefield Westgate		
Depart Down Main	Arrive Down Main	3
Pass Down Main	Arrive Down from Wakefield Kirkgate	2½
Depart Up to Wrenthorpe Sidings	Arrive Up Main	5
Depart Up to Wrenthorpe Sidings	Depart Down Main	3
Depart Down Main to Wakefield Kirkgate	Arrive Down Main	4½
Depart Up Main	Arrive Up Main	3½*
Depart Down platform in Up direction	Arrive Up Main	Simultaneous
Depart Down platform in Up direction to Wakefield Kirkgate	Depart Up	3
Depart/pass Up Main	Arrive Up or Down from Wakefield Kirkgate	4½
Depart Up Main	Arrive from Wrenthorpe Sidings	3
Arrive Down Main from Wakefield Kirkgate	Arrive Up Main	Simultaneous
Arrive Down from Wakefield Kirkgate	Depart Up Main	2
Depart / pass Down Main	Depart Wrenthorpe to Up or Down	3
* May be reduced by 1 minute if second train has at least 1 minute pathing allowance approaching Wakefield Westgate, however this should not be used for consecutive trains		
Minimum Turnround		
Arrive ECS from sidings, depart loaded	1	
Arrive loaded, depart ECS	1½	
Arrive ECS not from sidings, depart loaded	2	
No shunting from Knottingley or Leeds	5	
No shunting from Manchester	10	

Copley Hill West Junction		
Junction Margins		
First Movement	Second Movement	Margin
Pass to Copley Hill East	Pass Holbeck Junction to Wakefield	3
Pass Holbeck Junction to Wakefield	Pass to Copley Hill East	4*
Pass from Copley Hill East	Pass to Copley Hill East	4*
* May be reduced by one minute if the second train has at least 1 minute pathing time approaching Copley Hill		

Holbeck Junction		
Junction Margins		
First Movement	Second Movement	Margin
Pass from Wakefield	Pass to Bradford	2½
Pass to Bradford	Pass from Wakefield	3

Whitehall Junction		
Junction Margins		
First Movement	Second Movement	Margin

Whitehall Junction		
Pass To/from Leeds	Freight depart ex Engine Shed or Armley Jn	1
Pass To/from Leeds	Freight pass ex Engine Shed or Armley Jn	4
Freight pass ex Armley Jn or Engine Shed	Pass To/from Leeds	3*
Freight depart ex Armley Jn or Engine Shed	Pass To/from Leeds	4*
Pass to Copley Hill Chord	Pass from Morley	4½ [#]
Pass from Copley Hill Chord	Pass to Copley Hill Chord	3
Pass from Morley	Pass to Copley Hill Chord	3
* May be reduced by 1 minute for Light Diesel locomotives		
# May be reduced by one minute if the second train has at least 1 minute pathing time approaching Whitehall Jn		

Leeds West Junction (Crossing moves from Methley Junction)		
Junction Margins		
First Movement	Second Movement	Margin
Pass from Leeds	Pass to Leeds	3½*
Pass to Leeds	Pass from Leeds	2
* May be reduced by one minute if the second train has at least 1 minute pathing time approaching Leeds West Jn		

Leeds				
Connectional Allowance	10			
Dwell Time				
TPE,XC Peak	3 (07:30 to 09:30, 16:00 to 18:00)			
TPE,XC Off Peak	2			
All other Passenger	3			
Freight	3 Driver's TRTS activity			
Minimum Turnround				
	HST EWD	LH EWD	HST Sun	LH Sun
To/from London King's Cross	25	25	25	25
To/from London St Pancras	20		20	
EMU from Bradford FS/Skipton/Ilkley	5 But not two consecutive. The total of two consecutive turnrounds must not be less than 15 minutes.			
Short distance DMU	7*(except by special arrangement) * Between 1600 and 1900 EWD, trains to/from Sheffiled via Barnsley may turn round in 5 minutes, where the incoming service has a total of 5 minutes performance and pathing allowance approaching Engine Shed Junction/Leeds West Junction.			
EMU from Doncaster	10 Can reduce to 7 but not two consecutive			
Long distance DMU	15			
XC	20 (10 by exception and in agreement with Network Rail)			
TPE	8 (5 for trains starting from York)			
Platform End Conflicts				
First Movement	Second Movement			Margin
Arrive	Depart			1
Depart	Arrive			4½*
Arrive/Depart 10AB from West	Arrive 11/11AB from East			4*
Arrive 11/11AB from East	Arrive/Depart 10AB from West			4*
Through Line Margins				3½
Arrive in through platform from opposite ends				4
Following into through/bay platform after first arrival				4*
* May be reduced by one minute for trains that have at least 1 minute pathing time between Whitehall and Leeds				

Leeds	
West Junctions or Neville Hill West Junction and Leeds	
Platform Preferred Usage	
Trains should where possible use the following platforms	
VTEC turnrounds (91/HST)	Platform 6
CrossCountry Trains Eastbound	Platform 9 or 11
CrossCountry Trains Westbound	Platform 11 or 12
Through T.P.E. Eastbound	Platform 15
Through T.P.E. Westbound	Platform 16
Leeds NW/Harrogate lines	Platforms 1 – 5
Calderdale/Doncaster lines turnrounds	Platforms 10/11A/12A
Huddersfield/Normanton lines turnrounds	Platforms 12A/13/17
Platform Re-occupation	3 (same direction)
Platforming Restriction	
Trains from the West via the Through Road, planned to stop in Platform 12CD must not exceed 2x3 car class 185s.	
Restriction	
Under normal circumstances Freight trains must not be timetabled Eastbound through Platforms 15 and 16	
VTEC services not to be planned in Platforms 15 and 16 as services exceed platform length	
Train Watering Points	Leeds Station Platforms 1, 2, 3, 5, 6, 8, 11, 13 and 14

Marsh Lane Junction		
Junction Margins		
First Movement	Second Movement	Margin
Cross to DGL	Depart Leeds	½
Arrive Leeds	Cross to/from UGL	Same time

Neville Hill West Junction		
Junction Margins		
First Movement	Second Movement	Margin
Pass from Neville Hill Depot	Pass from Leeds (ML)	4
Pass to Up Sidings from Down	Pass from Cross Gates	4
Pass to Up Sidings from Down	Pass from Leeds (ML)	4
Pass from Branch to Down	Pass from Cross Gates	4
Pass from Leeds (ML)	Pass from Depot to UFL	3
Pass from Neville Hill Depot	Pass from Cross Gates	4
Pass from Cross Gates	Pass from Neville Hill Depot to UGL	3

LN838 LEEDS ARMLEY JUNCTION TO YORK SKELTON JUNCTION VIA HARROGATE		
Armley Junction		
Refer to LN922		
Horsforth		
Adjustments to Sectional Running Times		
Movement Up	Reason	Value
Train from Turnback Siding, not stopping Horsforth station, to be applied after Horsforth station	Acceleration from 15mph pointwork	½
Junction Margins		
First Movement	Second Movement	Margin
Train terminates in Turnback Siding	Next Down train arrive	4
Train terminates in Turnback Siding	Down pass station	3½
Arrive/pass Up platform from Turnback Siding	Down arrive station	4
Arrive/pass Up platform from Turnback Siding	Down pass station	3½
Down depart to Harrogate	Depart Turnback Siding	2
Down pass to Harrogate	Depart Turnback Siding	1½
Dwell Time		
HST 3		
MU 1		
Minimum Turnround in turnback siding	Terminates from Leeds – Depart to Leeds 3	
Restriction:		
<ul style="list-style-type: none"> All moves to/from Turnback Siding to be fully timed Standage on Turnback Siding is 112m maximum Trains going to Turnback Siding require a minimum 30s OP stop in station, access to Siding from Position Light Signal Down train cannot arrive station whilst train is signalled from Turnback Siding or vice versa, due to signal overlap Trains can reverse on Down Main adjacent to Turnback Siding 		

Harrogate		
Dwell Time		
All	2	
Adjustments to SRT : from Starbeck		
<ul style="list-style-type: none"> When arriving platform 3 from Starbeck and a train is ready to depart from platform 1 to Horsforth, to enable signaller to be satisfied that train from Starbeck has come to a stand, an extra {1} shall be added approaching Harrogate When arriving platforms 1 or 2 or Through Siding from Starbeck, an extra {1} is required due to slower approach 		
Junction Margins		
First Movement	Second Movement	Margin

Harrogate		
Depart Platform 1 to Leeds	Arrive from Leeds, having stopped Hornbeam Park	5½**
Depart Platform 1 to Leeds	Arrive from Leeds, not stopping Hornbeam Park	5**
Depart Platform 1 to Leeds	Arrive Platform 1 from York	3
Depart to Starbeck	Arrive from Horsforth, having stopped Hornbeam Park	8*
Depart to Starbeck	Arrive from Leeds, not stopping Hornbeam Park	7½*
Depart to Horsforth, calling at Hornbeam Park	Arrive from Starbeck	8½**
Depart to Horsforth, not calling Hornbeam Park	Arrive from Starbeck	7½**
*Can be reduced to 3½ if {1} added approaching Harrogate		
**Can be reduced to 4 if {1} added approaching Harrogate		
Minimum Turnround		
Same platform	10 HST 8 MU	
Replatform	15	
Notes		
<ul style="list-style-type: none"> Up direction platform 3 reoccupation is 3" for units which have shunted from other platform or Through Line. Train shunting reverse on Starbeck direction line. Although shunt moves within station limits are not timed, planners must satisfy themselves that such moves are robustly achievable HST uses platform 1. When in platform other trains cannot arrive/depart platform 2 or Through Line 		

Starbeck
Restriction Trains crossing at Starbeck must do so within 1 minute of each other except on isolated occasions to avoid excessive level crossing closure.

Knaresborough		
Junction Margins		
First Movement	Second Movement	Margin
Arrive from Cattal	Depart to Cattal	4
Arrive from Starbeck ECS (to shunt)	Following depart Starbeck	5½
Depart to Cattal	Following depart Starbeck	2
Depart Up platform to Starbeck	Arrive from Cattal	4
Arrive from Cattal	Depart Up platform to Starbeck	1½
Minimum Turnround		
Arrive loaded from Starbeck, depart ECS	5	
Arrive ECS from Starbeck, depart loaded	9	
Arrive loaded from Starbeck or Cattal, depart loaded	10	
Restrictions.		
<ul style="list-style-type: none"> All trains require a 30 second TW stop for Token Exchange Purposes to/from Cattal An up train cannot pass/depart Starbeck whilst preceding train is in up platform at Knaresborough, whether continuing towards Cattal or shunting between platforms. Reflected in margins above. When shunting between platforms, trains normally use crossover on viaduct. 		

Knareborough

- Departure from Up platform towards Starbeck should not be planned for passenger traffic

Cattal

Junction Margins (inclusive of allowance for token exchange, which is included in station duties)

First Movement	Second Movement	Margin
Arrive from Knareborough	Depart to Knareborough (if already in platform)	3
Arrive from Hammerton	Arrive from Knareborough	1½
Arrive from Knareborough	Arrive from Hammerton	3*

Restriction. All trains require a 30 second TW stop for Token Exchange Purposes

*Can be reduced to 2, if {1} added approaching Cattal

Hammerton

Junction Margins (inclusive of allowance for token exchange, which is included in station duties)

First Movement	Second Movement	Margin
Arrive from Poppleton	Depart to Poppleton (if already in platform)	3
Arrive from Cattal	Arrive from Poppleton	3
Arrive from Poppleton	Arrive from Cattal	3

Restrictions

- All trains require a 30 second TW stop for Token Exchange Purposes
- Trains cannot arrive simultaneously, due to a safety restriction regarding the use of the crossing

Poppleton

Junction Margins (inclusive of allowance for token exchange, which is included in station duties)

First Movement	Second Movement	Margin
Arrive from Hammerton	Arrive from York	2
Arrive from Hammerton	Depart to Hammerton	3
Arrive from York	Arrive from Hammerton	2

Restriction. All trains require a 30 second TW stop for Token Exchange Purposes

LN842 THORPE MARSH JUNCTION TO ADWICK JUNCTION

Applehurst Junction

Junction Margins

First Movement	Second Movement	Margin
Pass to Joan Croft Junction	Pass from Skellow Junction	4
Pass from Skellow Junction	Pass to Joan Croft Junction	3

Skellow Junction

Junction Margins

First Movement	Second Movement	Margin
Pass to Adwick Junction	Pass from Carcroft Junction	4
Pass from Carcroft Junction	Pass to Adwick Junction	4

LN852 HOLBECK JUNCTION TO BRADFORD INTERCHANGE		
Bradford Interchange		
Dwell Time		
All		3
Junction Margins		
First Movement	Second Movement	Margin
First train departs to Halifax or Leeds	Second train arrives from Halifax, if conflicting	5
First train departs to Halifax or Leeds	Second train arrives from Leeds	6*
* if incoming train has pathing time approaching Bradford the margin could be reduced to 5 mins		
Minimum Turnround		
From Leeds, Huddersfield or Hebden Bridge		5
From other locations		10
From London		30
Restriction		
<ul style="list-style-type: none"> Trains may only be planned to arrive into an occupied platform when that train is booked to be attached to a train already in the platform. 		

LN854 HALL ROYD JUNCTION TO COLTON JUNCTION		
Hebden Bridge		
Platform Re-occupation		
First Movement	Second Movement	Margin
Dep Platform 1 to Leeds	Arr Platform 1 ex Leeds	3½
Minimum Turnround		
From Leeds utilising same platform		6
From Leeds and replatformed		10

Milner Royd Junction		
Junction Margins		
First Movement	Second Movement	Margin
Pass to Hebden Bridge from Halifax	Pass towards Greetland	2
Pass towards Greetland	Pass from Halifax	3½
Arrive from Elland '* stop' (no pathing allowed between Elland and Milner Royd)	Pass from Halifax	3
Pass from Halifax	Pass from Elland	5
Pass to Halifax	Pass to Elland	7
Pass from Halifax	Depart from Elland direction	4

Greetland Junction		
Adjustments to Sectional Running Times		
Movement Eastbound	Reason	Value
Pass from Dryclough	Acceleration from 20 mph	½. To be applied after Greetland Junction
Movement Westbound	Reason	Value
Pass to Dryclough Junction	Approach Control	½. To be applied approaching Greetland Junction
Junction Margins		
First Movement	Second Movement	Margin
Pass to Dryclough Junction	Pass from Milner Royd Junction	3
Pass to Dryclough Junction	Depart to Bradley Wood	1
Pass from Milner Royd Junction	Pass to Dryclough Junction	2½
Pass from Milner Royd Junction	Depart to Dryclough Junction	1
Pass from Milner Royd Junction	Pass from Dryclough Junction	3½

Note:

- Trains from Huddersfield, going to Halifax, must include all allowances for acceleration and Approach Control, as shown under Bradley Wood and Greetland Junctions

Bradley Wood Junction		
Adjustments to Sectional Running Times		
Movement Westbound	Reason	Value
Trains from Bradley Jn	Acceleration from 20mph turnout	½ To be applied after Bradley Wood Junction
Movement Eastbound	Reason	Value
Trains going to Bradley Junction	Approach Control	½. To be applied approaching Bradley Wood Junction
Junction Margins		
First Movement	Second Movement	Margin
Pass to Bradley Junction	Up Freight pass from Heaton Lodge Junction	4
Pass to Bradley Junction	Up Passenger/Light Engine pass from Heaton Lodge Junction	3½
Pass to Bradley Junction	Depart Up L&Y towards Brighouse	2
Pass from Bradley Junction/Heaton Lodge Junction	Pass to Bradley Junction	2

Heaton Lodge Junction (for Up Trains only) NB Copy at LN860		
Junction Margins		
First Movement	Second Movement	Margin
Pass Up Fast	Depart Up Slow, towards same route	2

Heaton Lodge Junction (for Up Trains only) NB Copy at LN860		
Pass Up Fast	Depart Up Slow, towards different route	1½
Pass Up Fast or Up Slow	Pass from Up Fast or Up Slow towards either route	2½
Passenger/Light Engine depart Up Slow	Pass Up Fast going to either route	3½
Freight depart Up Slow	Pass Up Fast going to either route	4
Note:		
<ul style="list-style-type: none"> Normally trains from Dewsbury on Up Slow Line timed to be passed by a train on the Up Main, should be timed to stop at Heaton Lodge Jn 		

Mirfield East Junction NB Copy at LN860		
Adjustments to Sectional Running Times		
Movement Up	Reason	Value
Trains crossing to USL, having called at Ravensthorpe; to be applied approaching Mirfield East Junction	Slower speed from rest	½
Junction Margins		
First Movement	Second Movement	Margin
Up pass to up Fast or Up Slow	Pass to Down L & Y (not stopping Mirfield)	2
Up pass to Up Fast or Up Slow	Down depart Mirfield, going towards Horbury	½

Thornhill LNW Junction NB Copy at LN860		
Junction Margins		
First Movement	Second Movement	Margin
Pass towards Healey Mills	Pass from Dewsbury, not stopping Ravensthorpe	2*
Pass towards Healey Mills	Up arrive Ravensthorpe	3
*2½ if First Movement is a freight train		
Restriction		
Up trains from Dewsbury cannot be accepted into Ravensthorpe station when a train has already been routed towards Healey Mills, due to the overlap extending across Thornhill LNW Junction		

Dewsbury East Junction		
Junction Margins		
First Movement	Second Movement	Margin
Arrive Dewsbury Blue Circle*	Pass Thornhill LNW Junction towards Healey Mills	1
Arrive Dewsbury Blue Circle*	Pass Mirfield East Junction from Healey Mills	5½
Pass Thornhill LNW Junction towards Healey Mills	Pass towards Dewsbury Blue Circle	5½
Pass Thornhill LNW Junction towards Healey Mills	Depart towards Dewsbury Blue Circle	4
*Includes arriving at signal HM66 for light engine run round moves from Healey Mills		

Horbury Junction		
Adjustments to Sectional Running Times		
Movement Down	Reason	Value
Trains from Barnsley after Horbury Junction	Differential junction speed	1
Movement Up	Reason	Value
Trains to Barnsley Approaching Horbury Junction	Differential junction speed	½
Junction Margins		
First Movement	Second Movement	Margin
Pass to Healey Mills	Pass from Branch	3
Pass from Branch	Pass to Healey Mills	4 (UF) 3 (US)

Wakefield Kirkgate		
Adjustments to Sectional Running Times		
Movement Down	Reason	Value
Pass from Horbury Jn. To Calder Bridge Jn.	Differential junction speed.	1
Connectional Allowance	4	
Dwell Time		
All	1	
Minimum turnaround	5 Platform 3 only for services from Knottingley	
Minimum Turnround	10	
Junction Margins (when conflicting)		
First Movement	Second Movement	Margin
Arrive from Wakefield Westgate/Horbury Jn	Depart to Wakefield Westgate/Horbury Jn	1
Depart to Wakefield Westgate	Arrive pass from Horbury Junction	4
Depart Platform 3 to Wakefield Westgate	Depart Platform 1 to Horbury Junction	3
Depart to Horbury Junction	Arrive from Wakefield Westgate	3
Depart to Horbury Junction	Arrive from Pontefract	3
Depart to Horbury Junction	Arrive pass from Horbury Junction	4
Depart to Normanton	Arrive same platform from west	3
Depart to Calder Bridge	Arrive from Calder Bridge	4
Arrive-Platform 3 from Wakefield Westgate	Arrive Platform 2 from Normanton	3**
Arrive Platform 3 from Pontefract	Arrive Platform 2 from Normanton	3**
Arrive Platform 2 from Normanton	Arrive or Pass Platform	3
** Can be simultaneous if Arrival into Platform 2 from Normanton is given an additional 2 adjustment allowance		
Notes:		
<ul style="list-style-type: none"> Standage at Wakefield Westgate: Up/Down Through Line 705 feet/33slu; Up Goole (either direction) 637 feet/30slu 		

Turners Lane Junction		
Junction Margins		
First Movement	Second Movement	Margin
Pass to Wakefield Kirkgate	Pass from Calder Bridge,	3
Pass from Calder Bridge	Pass to Wakefield Kirkgate	3

Altofts Junction		
Adjustments to Sectional Running Times		
Movement Down	Reason	Value
Trains from Calder Bridge going to Europort, approaching Altofts Junction	Approach Control	3
Trains from Wakefield Kirkgate going to Europort, approaching Altofts Junction	Approach Control	2
Movement Up	Reason	Value
Trains coming from Europort, after Altofts Junction	Acceleration from rest	1
Junction Margins		
First Movement	Second Movement	Margin
Pass to Whitwood Junction	Pass from Methley Junction	3
Pass to Whitwood Junction	Depart from Europort	1½
Passenger pass from Methley Junction	Pass to Whitwood Junction (not stopping Normanton)	3
Freight pass from Methley Jn -Junction	Pass to Whitwood Junction (not stopping at Normanton)	3½
Passenger pass from Methley Junction	Pass to Whitwood Junction (Stopping at Normanton)	2
Freight pass from Methley Jn -Junction	Pass to Whitwood Junction (Stopping at Normanton)	2½
Passenger pass from Methley Junction/Whitwood Junction	Pass to Europort	2
Freight pass from Methley Junction/Whitwood Junction	Pass to Europort	2½
Pass from Europort	Pass to Whitwood Junction (not stopping Normanton)	4
Pass from Europort	Pass to Whitwood Junction (Stopping at Normanton)	3½
Pass to Europort	Pass from Methley Junction	6½
Pass to Europort	Pass from Whitwood Junction	5½
Pass to Europort	Pass to Whitwood Junction (not stopping Normanton)	6½
Pass to Europort	Pass to Whitwood Junction (Stopping at Normanton)	5½
Pass to Europort	Pass to Methley Junction (not stopping Normanton)	4
Pass to Europort	Pass to Methley Junction (Stopping at Normanton)	4
Restriction: Trains going to Europort block all lines when going into terminal, until train is completely 'inside' terminal (except for trains going towards Methley Junction). This is reflected in margins, above		
Note: Wakefield Europort has restricted capacity. If more than one train present, confirmation the further train(s) can be accommodated should be obtained from the operator		

Whitwood Junction		
Junction Margins		
First Movement	Second Movement	Margin
Pass from Altofts Junction	Pass to Methley Junction	2½
Pass to Methley Junction	Pass from Altofts Junction	3

Castleford		
Dwell Time		
	3 (reverse in Down platform)	
Junction Margins		
First Movement	Second Movement	Margin
Depart Down platform to Whitwood Junction	Arrive Down platform from Pontefract Monkhill	3
Depart Down platform to Pontefract Monkhill	Arrive from Whitwood Junction	2½
Pass Up Main	Arrive from Pontefract Monkhill	3
Depart Down platform to Pontefract Monkhill	Pass Up Main,	4
Arrive Down platform from Pontefract Monkhill	Pass Up Main	4
Minimum Turnround	6 from Leeds	

Milford Junction
Please Refer to 804

Sherburn Junction		
Adjustments to Sectional Running Times		
Movement Down	Reason	Value
Movement Up	Reason	Value
Non stop crossing from LSL at Church Fenton	Acceleration	1
Stopping train from LSL at Church Fenton After Church Fenton	Acceleration	½
Junction Margins		
First Movement	Second Movement	Margin
Pass to Milford Junction	Pass from Gascoigne Wood	Same time as southbound service passes Milford Junction
Pass from Gascoigne Wood	Pass to Milford Junction,	Same time as southbound service passes Church Fenton or 1 minute behind southbound service departing Sherburn in Elmet

Church Fenton
Adjustments to Sectional Running Times

Church Fenton		
Movement Down	Reason	Value
Train crossing to LSL at Church Fenton Approaching Church Fenton	Approach control	1
Non-stop train from Sherburn crossing to LSL Approaching Colton Junction	Acceleration	2
Movement Up	Reason	Value
Non stop train from LSL crossing to NNL Approaching Church Fenton	Approach control	2
Junction Margins		
First Movement	Second Movement	Margin
Pass from York	Depart to Leeds	2.5
Pass to York (Normanton lines)	Depart to Milford (Platform 3)	1
Pass to York (Normanton lines)	Pass to Milford (Platform 3)	3½
Pass/depart Platform 3 to Milford	Pass/arrive from Milford	4*
Arrive from York	Pass from York	3
Pass/arrive from York	Depart to York (crossing NNL)	1
Depart to York (crossing NNL)	Pass from York	3½
Depart to York (crossing NNL)	Arrive from York	5
Pass/depart to York (Platform 3)	Pass from York	5
Pass/depart to York (Platform 3)	Arrive from York	4
Pass from York (LSL or NNL)	Arrive Platform 3 via different line from NNL	3 \$
Pass from York (LSL)	Pass to York (crossing from DL to NNL)	4
* May be reduced by ½ if stopping at Sherburn		
\$ May be reduced to 2 if second train has a minimum of 2 minutes pathing time on approach.		

Colton South Junction		
Junction Margins		
First Movement	Second Movement	Margin
Up LSL pass Colton Junction	Down Crossing movement from NNL pass Colton Junction	6
Up LSL pass Colton Junction	Down Crossing movement depart from NNL signals at Colton South Junction	2
Down Crossing movement pass Colton Junction	Up LSL pass Colton Junction	3
Up Crossing movement pass Colton Junction	Down NNL pass Colton Junction	6
Down NNL pass Colton Junction	Up Crossing movement pass Colton Junction	3

LN858 MILNER ROYD JUNCTION TO MILL LANE JUNCTION		
Dryclough Junction		
Junction Margins		
First Movement	Second Movement	Margin
Pass from Greetland Jn	Depart from Halifax (to Milner Royd Jn)	1
Depart from Halifax (to Milner Royd Junction)	Pass from Greetland Jn	4½*
* May be reduced to 3½ minutes if train from Greetland has pathing time approaching Dryclough Junction		

Halifax		
Dwell Time		
All		1
Junction Margins		
All conflicting moves at south end		5*
* May be reduced to 4 minutes if second train has pathing time approaching Halifax		
Minimum Turnround		
From Leeds using same platform		5
From Leeds and replatformed		10
Restriction		
Trains from Bradford turning round in platform must depart 7 minutes before next train arrives		

Low Moor		
Dwell Time		
158/180		1
All other unit types		½

LN860 DIGGLE JUNCTION TO COPLEY HILL EAST JUNCTION		
Marsden		
Adjustments to Sectional Running Times		
Movement Down	Reason	Value
Departing up platform or UPL towards Huddersfield	Acceleration from 15mph pointwork	1
Movement Up	Reason	Value
Train Arriving Platform 3	Approach Control	1
Train departing Platform 3	Acceleration from 15mph pointwork	1*
*½ for Northern Services departing Platform 3 * 1 minute for TPE		
Junction Margins		
First Movement	Second Movement	Margin
Depart Marsden UP Loop or Up Main (in down direction)	Marsden pass in Up Direction	4½
Depart Up Loop or Up Main (in Down Direction)	Arrive Platform 2 or UPL (not stopping Slaithwaite)	5½
Depart Up Loop or Up Main (in Down Direction)	Up arrive Slaithwaite (see Restriction)	2
Pass/arrive Up	Depart Up Loop or Platform 2 (in Down Direction)	1
Pass Diggle Junction	Depart Up Loop	1
Restriction: Whilst a train is Departing Up Loop or Up Main in the Down Direction, an Up stopping train cannot arrive at Slaithwaite; reflected in margins above		
Minimum Turnround		
		5 from Huddersfield or Leeds

Huddersfield		
Adjustments to Sectional Running Times		
Movement Up	Reason	Value
Arriving trains Platforms 5	Approach control	1
Arriving trains Platform 6	Approach control	½
Arriving trains Platform 4 if already occupied	Approach control	½
Dwell Time 1		
Junction Margins (NB includes moves impacted by restrictive overlaps)		
First Movement	Second Movement	Margin
Up arrive Platform 1	Arrive Platform 4 from Penistone	3½
Up depart Platform 1	Up arrive Platform 1	2½
Depart Platform 1 towards Marsden	Arrive Platform 4 from Penistone	4
Depart Platform 1 towards Marsden	Depart Platform 4 towards Penistone	2½
Depart Platform 1 towards Penistone	Depart Platform 4 towards Marsden	2½
Arrive Platform 2	Depart Platform 1 or 4 towards Penistone	Simultaneous
Up arrive Platform 4	Down arrive Platform 4	1½
Up arrive Platform 4	Depart Platform 5 or 6	1
Down arrive Platform 4	Up arrive Platform 4	2
Down arrive Platform 4 from Penistone	Up arrive Platform 1	4+
Down arrive Platform 4 from Penistone	Up depart Platform 1	1
Down arrive Platform 4 from Penistone	Depart Platform 2	Simultaneous
Down arrive Platform 4	Arrive Platform 5 or 6	2½
Down arrive Platform 4	Down depart Platform 4, 5 or 6	1
Up depart Platform 4	Up arrive Platform 1	2½
Depart Platform 4 towards Marsden	Depart Platform 1 towards Penistone	2½
Depart Platform 4 towards Penistone	Depart Platform 1 towards Marsden	2½
Up depart Platform 4	Up arrive Platform 4	2½
Up depart Platform 4	Down arrive Platform 4 from Marsden	4+
Depart Platform 4 towards Marsden	Arrive Platform 4 from Penistone	4
Down depart Platform 4	Up arrive Platform 4	3½+
Down depart Platform 4	Down arrive Platform 4	4+
Down depart Platforms 4	Up arrive Platforms 5 or 6	3
Arrive Platforms 5/6	Down arrive Platform 4	4*
Arrive Platforms 5/6	Down depart Platform 4, 5 or 6	1
Depart Platforms 5/6	Up arrive Platforms 4	3½+
Depart platforms 5/6	Down arrive Platform 4	4½*
Depart Platforms 5/6	Arrive Platforms 5/6	3
Arrive Sidings (Downside)	Down depart Platform 4/5/6	1
Arrive Sidings (Downside)	Down depart Platform 8	1½
Arrive Sidings (Downside)	Down pass	3½
Shunt Move depart HU1412 signal towards Platform 4 5 or 6	Down pass Platform 8	3
Minimum Turnround		
From Leeds, Sheffield or Manchester	5	
From other locations beyond Leeds, Sheffield or Manchester	10 (can be reduced to 5 minutes if an <i>additional</i> five minutes dwell is included at Leeds, Sheffield or Manchester)	
To or from London	10	
* Can be reduced to 3 minutes if {½} added approaching Huddersfield for Approach Control +Can be reduced to 3 minutes if {1} added approaching Huddersfield for Approach Control		

Huddersfield	
Train Watering Points	Platform 4 emergency use only
Platform Restrictions	
Platform 5: Only 2 car class 14x or 150 can be signalled into no. 5 from signal HU770 (UML). 2 car trains longer than class 14x or 150 can only be shunted in from HU771412 sub-signal.	
Platform 6: This platform is not permissive from Up line (signal HU770) but is permissive from HU1412 sub-signal on Down Line. Class 153 units are not able to attach to any other unit in platform 6	
<u>Note</u> All Shunt moves to be fully timed.	

Bradley Junction		
Adjustments to Sectional Running Times		
Movement Up	Reason	Value
Pass from Bradley Wood Junction (not stopping at Deighton)	Acceleration from 15mph	2. To be applied after Bradley Junction
Pass from Bradley Wood Junction (stopping at Deighton)	Acceleration from 15mph	½. To be applied after Bradley Junction
Movement Down	Reason	Value
Pass to Bradley Wood Junction (not stopping at Deighton)	Approach Control	1½. To be applied Approaching Bradley junction
Pass to Bradley Wood Junction (stopping at Deighton)	Approach Control	1. To be applied Approaching Bradley junction
Junction Margins		
First Movement	Second Movement	Margin
Up pass from Heaton Lodge	Pass from Branch	2½
Up pass from Heaton Lodge	Depart from Branch	2
Pass from Branch	Down pass to Heaton Lodge East Junction (not stopping Deighton)	2½
Pass from Branch	Down pass to Heaton Lodge East Junction (with stop at Deighton)	3 plus Deighton dwell
Depart from Branch	Down pass to Heaton Lodge East Junction (not stopping Deighton)	3½
Depart from Branch	Down pass to Heaton Lodge East Junction (with stop at Deighton)	4 plus Deighton dwell
Down pass to Heaton Lodge East Junction	Depart from Branch	1
Down pass to Heaton Lodge East Junction	Pass from Branch	2½
Pass from Branch	Pass to Branch	2
Depart from Branch	Pass to Branch	2½
Pass to Bradley Wood Junction	Pass to Heaton Lodge East Junction	2½

Bradley Junction

Restriction:

- No pathing time to be inserted between Deighton station and Bradley Junction in either direction
- If an Up train is standing in Deighton station, a second Up train CANNOT pass Bradley Junction

Heaton Lodge Junction (for Up Trains only) NB Copy at LN854

Junction Margins

First Movement	Second Movement	Margin
Pass Up Fast	Depart Up Slow, towards same route	2
Pass Up Fast	Dep Up Slow towards different route	1½
Pass Up Fast or Up Slow	Pass from Up Fast or Up Slow towards either route	2½
Passenger/Light Engine depart Up Slow	Pass Up Fast going to either route	3½
Freight depart Up Slow	Pass Up Fast going to either route	4

Normally trains from Dewsbury on Up Slow Line timed to be passed by a train on the Up Main, should be timed to stop at Heaton Lodge Jn

Mirfield East Junction NB Copy at LN854

Adjustments to Sectional Running Times

Movement Up	Reason	Value
Trains crossing to USL, having called at Ravensthorpe; to be applied approaching Mirfield East Junction	Slower speed from rest	½

Junction Margins

First Movement	Second Movement	Margin
Up pass to up Fast or Up Slow	Pass to Down L & Y (not stopping Mirfield)	2
Up pass to Up Fast or Up Slow	Down depart Mirfield, going towards Horbury	½

Thornhill LNW Junction NB Copy at LN854

Junction Margins

First Movement	Second Movement	Margin
Pass towards Healey Mills	Pass from Dewsbury not stopping Ravensthorpe	2*
Pass towards Healey Mills	Up arrive Ravensthorpe	3

*2½ if First Movement is a freight train

Restriction

Up trains from Dewsbury cannot be accepted into Ravensthorpe station when a train has already been routed towards Healey Mills, due to the overlap extending across Thornhill LNW Junction

Dewsbury		
Dwell Time		
All		1
Junction Margins		
First Movement	Second Movement	Margin
Arrive Down platform	Pass Down Main	3
Pass Down Main	Depart Down Platform (stopping service)	1½

LN862 BARNSELY STATION JUNCTION TO HUDDERSFIELD		
Penistone		
Adjustment to Sectional Running Times		
Movement Up	Reason	Value
Arrive/pass when passing down teain arriving less than 3" before	Overlap extends over points : approach control	2
Dwell Time		
All		1
Junction Margins		
First Movement	Second Movement	Margin
Arrive / pass from Barnsley	Depart to Barnsley	1
Arrive / pass from Clayton West Junction	Depart single line to Clayton West Junction	1
Arrive from Clayton West Junction	Arrive / pass from Barnsley	3
Arrive from Barnsley	Arrive / pass from Clayton West Junction	3
Minimum Turnround		
	10 from Sheffield or Huddersfield	
Notes :		
Reversing trains : trains from south reverse in platform: from north mujst shunt via south end points		

Clayton West Junction		
Junction Margins		
First Movement	Second Movement	Margin
Pass from Penistone	Pass to Penistone	3

Stocksmoor		
Junction Margins		
First Movement	Second Movement	Margin
Arrive/pass from Huddersfield	Depart to Huddersfield	1
Arrive/pass from Huddersfield	Pass to Huddersfield	2

LN868 WINCOBANK JUNCTION TO HORBURY JUNCTION VIA BARNSELEY		
Meadowhall		
Adjustments to Sectional Running Times		
Movement Up	Reason	Value
Trains from Barnsley to Platform 4	Approach Control	1
Dwell Time		
All	1	
Junction Margins		
First Movement	Second Movement	Margin
Depart Platform 4 to Barnsley	Arrive Platform 4 from Barnsley	4
Depart Platform 4 to Sheffield via SL	Arrive Platform 4 from Sheffield via DF	3
Minimum Turnround		
	5 Platform 4 only from Barnsley or Sheffield	

Barnsley		
Dwell Time		
All	1	
Adjustment to Sectional Running Times		
Movement Up	Reason	Value
Up Train arriving down platform	Approach control	1
Up train from Penistone, not stopping	Acceleration	½
Movement Down	Reason	Value
Down train to Penistone, not stopping	Approach control	2
Junction Margins		
First Movement	Second Movement	Margin
Arrive/pass from Penistone	Depart to Penistone	Same time
Arrive/pass from Penistone	Pass to Penistone	1
Arrive/pass from Penistone	Pass to Wakefield	3½
Depart/pass to Wakefield	Arrive/pass from Penistone	4
Arrive/pass from Penistone	Depart to Wakefield	1
Depart to Sheffield from Down platform	Arrive/pass Down platform from Sheffield	4½
Depart/pass Down platform to Penistone/Wakefield	Arrive Down platform from Penistone/Wakefield	4
Platform reoccupation, down		3½
Platform reoccupation, up		4
Minimum Turnround		
From Sheffield, Huddersfield or Leeds	7	
From Sheffield, Huddersfield or Leeds including shunt	12	
From other locations excluding London St Pancras beyond Sheffield, Huddersfield or Leeds including shunt if required	15	

Barnsley	
From London St Pancras including shunt if required	20
Note: Two trains following each other in Down direction towards Horbury. Second train can depart/pass Barnsley at same time first train passes Wooley Coal Sdg signalbox. When Woolley Coal siding is switched out, second train can depart/pass Barnsley at same time first train passes Horbury Junction. In either case, the train must have {1} after Barnsley to allow for departing under a Y signal	

Horbury Junction	
Refer to 854	

LN872 ALTOFTS JUNCTION TO LEEDS WEST JUNCTION

Methley Junction		
Adjustments to Sectional Running Times		
Movement Down Northbound	Reason	Value
Trains from Castleford (not stopping at Woodlesford) Approaching Stourton Junction	Acceleration	1
Movement Up	Reason	Value
Trains to Castleford (not stopping at Woodlesford) Approaching Methley Junction	Differential junction speed	1
Junction Margins		
First Movement	Second Movement	Margin
Pass from Whitwood Junction	Pass to Altofts – stopping Passenger and Freight	3
Pass from Whitwood Junction	Pass to Altofts – non stop Passenger	4½
Passenger from Altofts Jn. and(not calling at Woodlesford) pass	Passenger from Whitwood Jn. and stopping at Woodlesford depart	2½
Pass to Altofts	Pass from Whitwood Junction	3

Stourton Junction		
Adjustments to Sectional Running Times		
Movement Down	Reason	Value
Trains from Methley Junction to FLT or A/D Line. Approaching Stourton Junction	Braking to lower speed lines	1
Movement Up	Reason	Value
Trains from FLT or A/D Line Approaching Methley Junction	Acceleration	2
Junction Margins		
First Movement	Second Movement	Margin
Pass from FLT or A/D Line	Pass Down Midland	4
Pass Down Midland	Pass from FLT or A/D Line	3
Pass from FLT or A/D Line	Pass to FLT or A/D Line	4
Up Passenger Pass from Engine Shed Jn.	Freight from Stourton RMC/Balm Rd. passes Hunslet South Jn.	4
Up Freight. Pass from Engine Shed Jn.	Freight from Stourton RMC/Balm Rd. passes	5

Stourton Junction		
	Hunslet South Jn.	

Hunslet Station Junction		
Junction Margins		
First Movement	Second Movement	Margin
Down train pass Stourton Junction	Pass to FLT or A/D Line	5
Pass to FLT or A/D Line from Up main	Down train pass Stourton Junction	3½

Engine Shed Junction		
Junction Margins		
First Movement	Second Movement	Margin
Pass from Whitehall Junction	Pass to Leeds	5
Pass to Leeds	Pass from Whitehall Junction	3
Pass from Whitehall Junction	Pass to Whitehall Junction	5
Pass to Leeds	Depart L4491 signal to Holbeck	1
Pass to Methley	Arrive L4491 signal from Leeds/Whitehall Road	3
Pass from Methley	Depart Holbeck depot	1
Pass from Whitehall Road	Depart Holbeck depot	4
Arrive Holbeck Depot	Pass to Leeds/Whitehall Road.	4

LN880 YORK TO SCARBOROUGH		
York		
Refer to LN600		

Scarborough Bridge Junction		
Refer to LN600 under York		

Malton		
Dwell Time		
All	1	
Junction Margins		
First Movement	Second Movement	Margin
Up depart platform	Down arrive	3½
Up depart platform	Down pass	2½
Down depart	Up arrive platform	4*
Down pass	Up arrive platform	4*
*Can be reduced by one minute if {1} added approaching Malton		
Note: A train may stand on the Up Main, level with the station platform. Maximum length 276 yards		

Seamer		
Adjustments to Sectional Running Times		
Movement Up	Reason	Value
Non-stopping trains towards Filey; approaching Seamer	Approach Control	½
Dwell Time		
All	1*	
* ½ for classes 14x, 150		
Junction Margins		
First Movement	Second Movement	Margin
Depart to York	Arrive/pass from Filey	5
Pass to York	Arrive from Filey	4
Arrive/pass from Filey	Depart to York	1
Arrive/pass from Filey	Pass to York	1½
Arrive from Filey	Depart to Filey	Same time*
*For single line occupancy at Seamer South Jn		

Scarborough		
Adjustments to Sectional Running Times		
Movement Down	Reason	Value
Train entering occupied platform	Calling on signal	1
Junction Margins (when conflicting)		
First Movement	Second Movement	Margin
Arrive from Seamer	Depart to Seamer	1
Depart to Seamer	Arrive From Seamer	5*
Depart platform 1 to Seamer	Depart Excursion Sidings	2½
*Can be reduced by one minute if {1} added approaching Scarborough		
Minimum Reversal		
	5 DMU	
Minimum Turnround		
TPE	10	
From Hull or York	10	
From Leeds	15	
From points beyond Hull or Leeds	20**	
** This may be reduced to a minimum of 10 minutes by the number of minutes of additional station dwell at Hull, Bridlington, or York, of the incoming service		
Train Watering Points		
	Scarborough station. Both the platform line on which the train is standing and the adjacent platform line from which the watering will take place must be blocked whilst the operation takes place	
Restriction: Platform 5 is barred to classes 153 156 185 150 155		
Excursion Sidings. Trains arrive into platform 1, then propel into the Excursion Sidings, then run round, propelling back into platform 1 before departure. The Excursion Sidings can accommodate a second train but this can only take place after the first train has completed a run round; therefore can only leave platform 1, 30 minutes after the first. The second train can only commence a run round after the first train has returned to platform 1; planners must satisfy themselves there is adequate time between the first train arriving platform 1, and the second train moving to that platform. All such moves to be fully timed		

LN882 WAKEFIELD KIRKGATE WEST JUNCTION TO GOOLE POTTER'S GRANGE JUNCTION

Wakefield Kirkgate

Refer to LN854

Calder Bridge Junction

Junction Margins

First Movement	Second Movement	Margin
Pass to Turners Lane Junction	Pass from Wakefield Kirkgate, going to Calder Bridge Junction	2½
Pass from Wakefield Kirkgate	Pass to Turners Lane Junction from Oakenshaw Junction	2
Arrive Up Goods Loop	Pass Up Main	4

Oakenshaw Junction

Junction Margins

First Movement	Second Movement	Margin
Pass to Crofton West Junction	Pass to Oakenshaw South Junction	3
Pass to Oakenshaw South Junction	Pass to Oakenshaw South Junction	4

Crofton West Junction

Adjustments to Sectional Running Times

Movement Down	Reason	Value
Trains to Hare Park approaching Crofton West Junction	Approach Control	1

Junction Margins

First Movement	Second Movement	Margin
Pass to Hare Park Junction	Pass from Crofton East Junction	4
Pass from Crofton East Junction	Pass to Hare Park Junction	3

Crofton East Junction

Junction Margins

First Movement	Second Movement	Margin
Pass to Oakenshaw South Junction	Pass from Crofton West Junction	3
Pass from Crofton West Junction	Pass to Oakenshaw South Junction	3

Pontefract Monkhill		
Junction Margins		
First Movement	Second Movement	Margin
Depart to Castleford	Arrive from Crofton East Junction	4½
Arrive from Crofton East Junction	Depart to Castleford	4
Passenger depart to Glasshoughton	EDU shunt arrive from Pontefract East Jn. (Monkhill Goods Branch Single Line)	3
Minimum Turnround	11 minutes for trains from Wakefield, via Pontefract East Junction	

Pontefract East Junction		
Junction Margins		
First Movement	Second Movement	Margin
Pass from Ferrybridge	Pass to Knottingley West Junction	4
Pass to Knottingley West Junction	Pass from Ferry bridge	3

Knottingley West Junction								
Adjustments to Sectional Running Times								
Movement Up	Reason							Value
Trains from Pontefract to Knottingley C & W (Knottingley Depot) Approaching Knottingley West Junction	Approach control							1
Junction Margins								
2 nd move → 1 st move ↓	From Shaft-holme to Crofton	From Shaft-holme to Ferry-bridge	From Goole to Crofton	From Goole to Ferry-bridge	From Ferry-bridge to Goole	From Ferry-bridge to Shaft-holme	From Crofton to Goole	From Crofton to Shaft-holme
From Shaftholme to Crofton	–	4	4	4	No conflict	No conflict	No conflict	No conflict
From Shaft-holme to Ferrybridge	4	–	4	4	No conflict	No conflict	4	4
From Goole to Crofton	4	4	–	4	No conflict	4	No conflict	4
From Goole to Ferrybridge	4	4	4	–	No conflict	4	4	4
From Ferry-bridge to Goole	No conflict	No conflict	No conflict	No conflict	–	4	4	3
From Ferrybridge to Shaftholme	No conflict	No conflict	3	3	4	–	3	3
From Crofton to Goole	No conflict	3	No conflict	3	4	3	–	4
From Crofton to	No conflict	3	3	3	3	4	4	–

Knottingley West Junction							
Shaftholme							
Operating Restriction							
<ul style="list-style-type: none"> Knottingley West Junction must be clear before train is allowed to depart Ferrybridge Signal 6624 for environmental reasons. This does not apply to those trains worked by Class 59, 60 or 66 locomotives 							

Knottingley	
Minimum Turnround	5 minutes for trains from Leeds or Wakefield. When required ECS can run via England Lane and UGL

Knottingley East Junction (England Lane)		
Adjustments to Sectional Running Times		
Movement Down	Reason	Value
Freight trains from Knottingley TMD or Knottingley South Junction. After Knottingley East Jn	Differential junction speed	3
Junction Margins		
First Movement	Second Movement	Margin
Pass from Shaftholme	Pass to Crofton	5
Pass to Crofton	Pass from Shaftholme Junction	3
Pass from Knottingley South Junction	Pass to Knottingley South Junction	5

Sudforth Lane S.B.		
Adjustments to Sectional Running Times		
Movement Down	Reason	Value
Trains from Sudforth Lane Sidings towards Whitley Bridge. Approaching Whitley Bridge	Acceleration	2
Movement Up	Reason	Value
Trains from Sudforth Lane Sidings towards Knottingley East Jn. After Sudforth Lane SB	Differential junction speed	2

Whitley Bridge Junction		
Junction Margins		
First Movement	Second Movement	Margin
Pass from Eggborough PS	Pass Down Goole	4
Pass Down Goole	Pass from Eggborough PS	4

Drax Branch Junction		
Junction Margins		
First Movement	Second Movement	Margin

Drax Branch Junction		
Pass from Drax PS	Pass Down Goole	4
Pass Down Goole	Pass from Drax PS	4

Snaith
Operating Instruction All Up trains to stop for level crossing purposes

Rawcliffe
Operating Instruction All Down trains to stop for level crossing purposes

LN886 MONK BRETTON LOOP TO CROFTON EAST JUNCTION
Monk Bretton Loop
Restriction: One train working exists between Oakenshaw South Junction and Monk Bretton. Monk Bretton loop is only used for locomotive run round

LN888 HATFIELD AND STAINFORTH (STAINFORTH JUNCTION) TO FERRYBRIDGE NORTH JUNCTION		
Nottinghamly South Junction		
Adjustments to Sectional Running Times		
Movement Down	Reason	Value
Trains towards Nottinghamly East Junction Approaching Nottinghamly Sth Jn.	Approach control	2
Freight trains towards Nottinghamly West Junction. Approaching Nottinghamly Sth Jn.	Approach control	2
Movement Up	Reason	Value
Trains from Nottinghamly East Junction After Nottinghamly Sth Jn	Acceleration	1
Freight trains from Nottinghamly West Junction After Nottinghamly Sth Jn.	Acceleration	2
Junction Margins		
First Movement	Second Movement	Margin
Pass from Nottinghamly East Junction	Pass to Nottinghamly East Junction	3
Pass from Nottinghamly West Junction	Pass to Nottinghamly East Junction	3
Pass to Nottinghamly East Junction	Pass from Nottinghamly West Junction	4

Thorpe Marsh Junction		
Junction Margins		
First Movement	Second Movement	Margin
Pass to Haywood Junction	Pass from Applehurst Junction	3
Pass from Applehurst Junction	Pass to Haywood Junction	3

Haywood Junction		
Junction Margins		
First Movement	Second Movement	Margin
Pass from Thorpe Marsh Junction	Pass to Shaftholme Junction	3
Pass to Shaftholme Junction	Pass from Thorpe Marsh Junction	3

LN898 NEVILLE HILL EAST JUNCTION TO HULL	
Cross Gates	
Dwell Time	
DMU	1 minute for trains arriving in Leeds 0730 – 0900 and departing Leeds 1600 – 1800 SX

Garforth	
Dwell Time	
DMU	1 minute for trains arriving in Leeds 0730 – 0900 and departing Leeds 1600 – 1800 SX

East Garforth	
Dwell Time	
DMU	1 minute for trains arriving in Leeds 0730 – 0900 and departing Leeds 1600 – 1800 SX

Micklefield		
Junction Margins		
First Movement	Second Movement	Margin
Pass from York	Arrive from Selby	3
Pass from York	Freight pass from Selby	4½
Arrive/pass from York	Trains arriving from Leeds, going forward towards Hull	4½*
Pass from York	Pass to Hull	4
Arrive from York	Pass to Hull	4½
Pass to Hull	Arrive from York	3
Pass to Hull	Pass from York	3
Depart to Hull	Pass from York	3½
Pass from Hull	Arrive from York	3
Depart to Hull/York	Following train pass to other direction	3

* If a train is arriving/passing from York, a train travelling towards Selby cannot be accepted into Micklefield station as the junction signal is to the west of the station.

Restrictions Trains of classes 4, 6, 7 and 8 which are over 2000 tonnes in weight must be given a clear run from Hambleton to Micklefield. No pathing time is to be planned.

Gascoigne Wood		
Adjustments to Sectional Running Times		
Movement Down	Reason	Value
Passenger trains from Sherburn/Milford Junction. Approaching Hambleton West Jn	Differential junction speed	½
Freight trains from Micklefield. Approaching Hambleton West Jn	Differential junction speed	-2
Movement Up	Reason	Value
Passenger trains to Sherburn/Milford Junction Approaching Gascoigne Wood Jn	Approach control	1
Freight trains to Micklefield Approaching Gascoigne Wood Jn	Differential junction speed	-1
Junction Margins		
First Movement	Second Movement	Margin
Pass from Micklefield	Pass to/from Sherburn Junction	3½
Pass to/from Micklefield	Pass from Milford Junction	5
Pass from Micklefield	Depart from Milford Junction	2½
Pass to Micklefield	Depart from Milford Junction	2
Pass from Sherburn Junction	Pass to Sherburn Junction	3½
Pass to Sherburn Junction	Pass from Micklefield	3
Pass to Sherburn Junction	Pass from Milford Junction/West Yard	5
Pass to Sherburn Junction	Pass from Sherburn Junction	4½*
Freight depart/pass from Milford Junction	Pass to Micklefield	3½
Freight depart/pass from Milford Junction	Freight pass to Milford Junction	3
Freight pass to Milford Junction	Freight pass from Milford Junction	6
* 4 if non-stop at Sherburn		

Hambleton West Junction		
Junction Margins		
First Movement	Second Movement	Margin
Pass to Hambleton South Junction	Pass from Selby	3½
Pass from Selby	Pass to Hambleton South Junction	2½

Hambleton East Junction		
Adjustments to Sectional Running Times		
Movement Down	Reason	Value
Trains from Hambleton North Junction Approaching Selby	Differential junction speed	½
Movement Up	Reason	Value
Trains to Hambleton North Junction Approaching Hambleton East Junction	Approach control	½

Selby		
Dwell Time		
All		1
HST		2
Junction Margins		
First Movement	Second Movement	Margin
Depart to Leeds	Arrive Platform 3 from Leeds via Up main	7
Depart to Leeds or Doncaster from Platform 1	Arrive Platform 1 from Leeds or Doncaster	4½
Depart to Leeds or Doncaster from Platforms 1/2/3	Arrive Platform 2 from Hull	3
Depart to Doncaster from Platform 2	Arrive Platform 3 from Leeds	6
Depart to Doncaster from Platform 2	Depart Platform 3 to Leeds	2
Arrive from Leeds (Platform 3)	Arrive from Hull (Platform 2)	3
Arrive from Doncaster (Platform 1)	Arrive from Leeds (Platform 3)	3½
Freight crosses at Selby West Junction to Temple Hirst Junction	Depart Selby to Leeds	1
Note: Trains conveying passengers are not permitted to arrive in Platform 2 from Leeds.		
Minimum Turnround		
From Doncaster or York		5*
From Leeds		7*
From beyond Doncaster, Leeds or York		10*
* An additional 10 minutes is required if the train needs to be replatformed		

Howden		
Dwell Time		
First Hull Trains Class 180		1

Gilberdyke		
Adjustment to Sectional Running Times		
Movement Up	Reason	Value
Services approaching Gilberdyke non stop to Goole	Differential junction speed	½
Junction Margins		
First Movement	Second Movement	Margin
Pass to Selby	Pass/arrive from Goole	4
Depart to Selby	Pass/arrive from Goole	4½
Pass/arrive from Goole	Pass to Selby	4
Pass/arrive from Goole	Depart to Selby	1

Brough		
Dwell Time		
All		1
HST		2

Hessle East Junction		
Junction Margins		
First Movement	Second Movement	Margin
Pass from Yards	Before stopping service departs Hessle	1
Pass from Yards	After fast service departs Brough	3
Pass from Yards	After fast service passes Brough	2
Depart Hessle	Pass from Yards	5
Pass Brough	Pass from Yards	8
Depart Brough	Pass from Yards	10

Hessle Road Junction		
Junction Margins		
First Movement	Second Movement	Margin
Depart/pass from Branch	Pass to Hull	4
Pass to Hull	Depart/pass from Branch	3
Pass to/from Branch	Next train to/from Branch	4

Anlaby Road Junction		
Junction Margins		
First Movement	Second Movement	Margin
Pass from Branch	Before Down service arrives Hull	5
Arrive Hull	Pass from Branch	1

Hull		
Dwell Time		
All	3 plus any differential allowance for arriving train	
Fuelling allowances		
The following allowances must be made when fuelling is required (only one trip at any one time)		
HST	40	
2 cars	10	
3 cars	15	
4 cars	20	
6 cars	30	
8 cars	40	
Junction Margins		
First Movement	Second Movement	Margin
Arrive Platforms 4 to 7 from Selby or Bridlington	Depart Platform 2 or 3 to Selby	Same time
Arrive Platforms 2 or 3 from Selby or Bridlington	Depart Platforms 4 to 7 to Selby or Bridlington	1
Arrive from Selby	Arrive from Bridlington and vice versa	3
Depart Platform 2 or 3 to Selby	Depart Platforms 4 to 7 to Selby or Bridlington	Same time
Depart Platforms 4 to 7 to Selby	Depart Platform 2 or 3 to Bridlington	3
Depart to Selby	Arrive from Selby or Bridlington	4
Depart to Bridlington	Arrive from Bridlington	5
Depart to Bridlington	Arrive from Selby	4

Hull	
ECS from Botanic Gardens must arrive 5 minutes in front of or behind where conflicts occur	
Minimum Turnround	
From Beverley	7
From Bridlington/Doncaster/ Leeds/ Scarborough and York	10
From beyond Doncaster/Leeds/ York	20
TPE	8
Train Watering Points	
	Available at the station

LN902 MICKLEFIELD JUNCTION TO CHURCH FENTON NORTH JUNCTION	
Church Fenton	
Refer to LN854	

LN912 THORNE JUNCTION TO GILBERDYKE JUNCTION		
Goole		
Adjustments to Sectional Running Times		
Movement Up	Reason	Value
Services approaching Goole with an extended dwell (greater than 2 minutes)	Approach Control	1½
Up freight arriving into Goole Loop Approaching Goole	Approach Control	2
Services approaching Goole non stop from Brough	Acceleration	½
Dwell Time		
All		1
Junction Margins		
First Movement	Second Movement	Margin
Arrive from Doncaster	Depart to Knottingley	Same time
Depart to Knottingley	Arrive from Doncaster	5
Terminate from Doncaster or Knottingley	Arrive from Doncaster or Knottingley	8
Arrive in East End siding	Arrive from Hull	5
Down Freight pass/arr	Up train pass/dep	Same time
Down Passenger pass/arr	Up Freight depart/pass	Same time
Up Freight pass/dep	Down Freight pass/arr	8
Up Passenger dep/pass	Down Freight pass/arr	7
Minimum Turnround		
	10 trains from Doncaster, Hull Leeds and Sheffield. Must be replatformed	
Restrictions		
Freight trains must not be timed to pass each other over Goole Swing Bridge. The following two margins should therefore apply		
Up Freight passes Goole same time as Down freight passes Goole		
Down Freight passes Goole 10 minutes before Up Freight passes Goole		

LN914 HULL TO SEAMER WEST JUNCTION

Hull

Refer to LN898

Cottingham

Dwell Time

All	1 Trains arriving Hull 0730 – 0900 weekdays, or departing Hull 1600 – 1800 weekdays
-----	---

Beverley

Dwell Time

All	1
-----	---

Junction Margins

First Movement	Second Movement	Margin
Depart Down platform to Hull	Arrive Down platform from Hull	4

Minimum Turnround

From Hull Same platform	5
From Hull replatform, also From Doncaster, Leeds or York	10
From beyond Doncaster, Leeds or York.	20*

* May be reduced to a minimum of 10 minutes if the incoming/outgoing services have additional station dwell at Hull

Driffield

Dwell Time

All	1
-----	---

Bridlington

Adjustments to Sectional Running Times

Movement Up	Reason	Value
Trains from Hunmanby arriving at Bridlington whilst another train is in the Bridlington to Driffield section.	Approach release BN108 signal	1

Dwell Time

All	1
-----	---

Junction Margins

First Movement	Second Movement	Margin
Arrive from Hunmanby	Depart to Hunmanby.	1
Depart to Driffield	Arrive Bay platforms from Driffield	4
Arrive bay platform from Driffield	Arrive from Hunmanby	4
Arrive from Hunmanby	Arrive Bay Platform from Driffield	3½

Bridlington	
Minimum Turnround	
From Hull	6 (not shunting between platforms) 12 (shunting between platforms)
From Doncaster, or York	10 12 (shunting between platforms)
From Scarborough	12
From beyond Doncaster, or York.	20*
* May be reduced to a minimum of 10 minutes if the incoming/outgoing services have additional station dwell at Hull	
Restriction: A train terminating in platform 6 cannot arrive simultaneously with a train arriving from Hunmanby. Reflected in Margins above	
Note: Platforms 7 and 8, and Carriage Sidings are out of use. If reinstated, all Rules at this location will require revision	

Hunmanby		
Junction Margins		
First Movement	Second Movement	Margin
Arrive/pass from Bridlington	Depart to Bridlington	1

Restriction:
Up train on Up line – Additional requirements associated with train lengths.
If it is necessary for a train with a length of more than 450 yards (420 metres) to pass over the crossing in the Up direction on the Up Bridlington line, the crossing must be under local control and the attendant advised in sufficient time before the train approaches the crossing
Reason for Restriction:-
Signal SR124 at the west end of Hunmanby Station is designed not to clear to a proceed aspect until a train has come to a stand at it. The design of the crossing means there is a possibility that the barriers will raise and the lights extinguish before a train with a length of more than 450 yards (420 metres) has passed clear of the crossing. Therefore, when such trains are planned to run over this route, arrangements must be made in advance for the crossing to be placed under local control

Filey		
Dwell Time		
All	1	
Junction Margins		
First Movement	Second Movement	Margin
Arrive/pass from Scarborough	Depart to Scarborough	1
Arrive/pass from Scarborough	Pass to Scarborough	1½
Minimum Turnround		
From Scarborough	5	
Arrive loaded from other locations, return ECS or arrive ECS, return loaded	8	
From other locations, arrive and depart in service	10	

LN916 HESSLE ROAD JUNCTION TO SALTEND

Springbank South Junction

Junction Margins

First Movement	Second Movement	Margin
Pass from Single Line	Re-occupy Single Line	3

Hull Dock Security Gates

Operating Stop | 4 All trains to stop for handover of 2 way radio.

Bridges Junction

Junction Margins

First Movement	Second Movement	Margin
Pass to Hull Docks	Pass from Hull Docks	5
Pass to Hull Docks	Start from Hull Docks	3

LN922 WHITEHALL WEST JUNCTION TO HELLIFIELD SOUTH JUNCTION

Armley Junction

Junction Margins

First Movement	Second Movement	Margin
Pass Up Shipley (Passenger)	Cross from Down Harrogate to Shipley	3
Pass Up Shipley (Freight)	Cross from Down Harrogate to Shipley	4
Cross from Down Harrogate to Shipley	Pass Up Shipley	3
Cross from Down Harrogate to Shipley	Freight depart Down Shipley	2
Pass to Harrogate	Cross from Up Shipley to Up Harrogate	3
Cross from Up Shipley Slow to Up Harrogate	Pass to Harrogate	2½

Kirkstall Loop

Junction Margins

First Movement	Second Movement	Margin
Arrive Down Loop	Pass Armley Junction in Down direction	1
Pass Apperley Junction in Down direction	Depart Down Loop	Same time
Arrive Up Loop	Pass Apperley Junction in Up direction	Same time
Pass Armley Junction in Up direction	Depart Up Loop	Same time

Apperley Junction

Adjustments to Sectional Running Times

Movement Up	Reason	Value
Trains from Ilkley to Leeds Approaching Armley Junction	Acceleration	½

Junction Margins

Apperley Junction		
First Movement	Second Movement	Margin
Pass Up Main	Pass to Branch	3
Pass to Branch	Pass Up Main	3
Pass from Branch	Pass to Branch	3

Dockfield Junction		
Junction Margins		
First Movement	Second Movement	Margin
Pass from Ilkley	Pass to Ilkley/Leeds	3
Pass to Shipley Platform 2	Pass from Shipley Platform 3	3
Pass to Leeds	Pass from Ilkley	2½
Pass from Shipley Platform 3	Pass to Shipley Platform 2	3
Pass from Shipley Platform 1	Pass from Shipley Platform 3 (one train to Leeds, one to Ilkley)	2½
Pass from Shipley Platform 3	Pass from Shipley Platform 1 (one train to Leeds, one to Ilkley)	2½

Note: When a loco hauled or HST service approaches Platform 3 from Bradford it has to pass the Starting signal to platform the train, thus the route has to be cleared across Shipley East and Dockfield Junction. Therefore 4 minutes must be allowed after any other movement across Shipley East/Dockfield Jn

Shipley		
Adjustments to Sectional Running Times		
Movement Up F.Sq/Down Shipley	Reason	Value
Trains from Bradford to Skipton Approaching Shipley	Approach control	½
Trains from Bradford to Skipton Approaching Saltaire	Acceleration from low speed	½
Movement Up Shipley/Dn F.Sq.	Reason	Value
Trains from Skipton to Bradford Approaching Shipley	Approach control	½
Trains from Skipton to Bradford Approaching Frizinghall	Acceleration from low speed	1
Dwell Time		
DMU/EMU	1	
LH/HST	1½	
Junction Margins		
First Movement	Second Movement	Margin
Arrive Platform 3 from Bradford	Depart Platform 5 to Bradford	1
Depart Platform 3 or 5 to Bradford	Arrive Platform 3 or 5 from Bradford	4
Arrive Platform 3 or 4 from Dockfield Jn.	Depart Platform 5 to Bradford	3
Depart Platform 5 to Bradford	Arrive Platform 3 or 4 from Dockfield Jn	4
Arrive Platform 5 from Keighley	Depart Platform 2 to Keighley	1
Depart Platform 2 or 5 to Keighley	Arrive Platform 5 from Keighley	4½

Please note that a train formed of MKIV and HST stock cannot be planned into Platform 3W for use of the short overlap. This is because the train cannot be fully platformed in Platform 3 unless it can draw past Signal 3966. Such a train must not be allowed into the platform until the route is set from Signal 3966 to Signal 3934. VTEC HST and MKIV trains to/from Bradford which stop at Shipley must use Platform 3

ShIPLEY		
Overlap Restrictions		
Movement	Conflict	Margin
Arrive Platform 5 from Skipton	Arrive Platform 3 from Bradford (and vice versa)	3*
Arrive Platform 5 from Bradford	Arrive Platform 2 from Leeds (and vice versa)	3*
Arrive Platform 3 from Bradford	Arrive Platform 2 from Leeds (and vice versa)	3*
*These moves can be made simultaneous by using the short overlap, planned using platforms 2W, 3W and 5W, and with appropriate adjustment as above.		

SaltAire	
Dwell Time	
	1 Only trains arriving at Leeds or Bradford FS between 0730 and 0900 EWD, or departing Leeds or Bradford FS between 1600 and 1800 EWD

Bingley	
Dwell Time	
DMU	1 Only trains arriving at Leeds or Bradford FS between 0730 and 0900 EWD, or departing Leeds or Bradford FS between 1600 and 1800 EWD
EMU	1

Crossflatts	
	1 Only trains arriving at Leeds or Bradford FS between 0730 and 0900 EWD, or departing Leeds or Bradford FS between 1600 and 1800 EWD

Keighley		
Dwell Time		
DMU/EMU	1	
LH/HST	1½	
Junction Margins		
First Movement	Second Movement	Margin
Train terminate Keighley	Following train arrive Keighley	7
Minimum Turnround		
	10 including shunt	

Steeton and Silsden	
Dwell Time	
	1 Only trains arriving at Leeds or Bradford FS between 0730 and 0900 EWD, or departing Leeds or Bradford FS between 1600 and 1800 EWD

Skipton		
Adjustments to Sectional Running Times		
Movement Down	Reason	Value
Passenger trains arriving in Platform 1 or 4	Approach control	½
Down Passenger trains routed via/depart Platform 4	Differential junction speed	1
Down Freight trains routed via Platform 4	Differential junction speed	2
Up trains routed via Platform 3	Approach control	2
Dwell Time		
All	2	
Junction Margins		
First Movement	Second Movement	Margin
Depart to Leeds	Arrive from Leeds	4
Arrive from Leeds	Depart to Leeds	1
Depart to sidings	Arrive from North	5
Arrive from sidings	Depart to sidings	2
Arrive from North	Depart to sidings	1
Arrive Platform 1	Arrive Platform 2 from North	3
Arrive Platform 2 from North	Arrive Platform 1	3
Arrive Platform 2X from South	Arrive Platform 3 from North	5
Depart Platforms 1/3/4 to the South	Arrive Platform 2 from North	3
Re-occupy platforms in either direction		4
Minimum Turnround		
DMU/EMU	5 There must not be 2 consecutive 5 minute turnrounds, and the total of any two consecutive must be at least 15 minutes.	
Other Restriction		
Up Freight trains requiring to be held for pathing purposes to stand at Signal L4046. This branch line to Rylstone line operates as One Train Working With No Train Staff. Therefore only one train is allowed on this branch line at any one time. A second train is not allowed to enter the branch line/depart Skipton Down Through Siding until the first train has returned to Skipton, or its loco if it has left wagons at Rylstone and has returned to Skipton. Only one train can perform a run round movement at Skipton at a time.		
Train Watering Points		
	Available at the station	

Gargrave		
Dwell Time		
All	½	

LN924 APPERLEY JUNCTION TO ILKLEY		
Guiselley/Esholt Junctions		
Junction Margins		
First Movement	Second Movement	Margin
Arrive Guiselley from Leeds	Depart to Leeds	Same time
Arrive Guiselley from Bradford	Depart to Bradford	1

LN924 APPERLEY JUNCTION TO ILKLEY		
Guiseley/Esholt Junctions		
Arrive Guiseley from Leeds	Depart to Bradford	1
Depart Guiseley to Bradford	Arrive from Leeds	5

Guiseley	
Dwell Time	
All	1

Burley-in-Wharfedale	
Dwell Time	
All	1

Ilkley		
Adjustments to Sectional Running Times		
Movement Down	Reason	Value
Trains arriving in Platform 2	Approach control	½
Trains arriving into an occupied platform	Approach control	½
Junction Margins		
First Movement	Second Movement	Margin
Arrive Platform 2	Depart Platform 1	1
Depart Platform 1	Arrive Platform 2	5
Depart Platform 1	Arrive Platform 1	4
Depart Platform 2	Arrive Platform 2	5
Minimum Turnround	5 There must not be 2 consecutive 5 minute turnrounds, and the total of any two consecutive must be at least 15 minutes.	
Operating Note: The last arriving train of the night should be planned to run in and be berthed on top of the penultimate arrival in Platform 1 for cleaning and maintenance purposes.		

LN928 SHIPLEY EAST JUNCTION TO BRADFORD FORSTER SQUARE		
Bradford Forster Square		
Minimum Turnround	5 There must not be 2 consecutive 5 minute turnrounds, and the total of any two consecutive must be at least 15 minutes.	
Platform End Conflicts		
First Movement	Second Movement	Margin
Arrive Platform 2 or 3	Depart Platform 1, 2 or 3	1
Depart Platform 2 or 3	Arrive Platform 2 or 3	3
Depart Platform 1	Arrive Platform 1, 2 or 3	5
Train Watering Points	Available at the station	

LN930 SKIPTON MIDDLE JUNCTION TO RYLSTONE
--

RYLSTONE

Operating Note:

This Line operates as One Train Working With No Train Staff. Therefore only one train is allowed on this branch line at any one time. A second train is not allowed to enter the branch line/depart Skipton Down Through Siding until the first train has returned to Skipton, or its loco if it has left wagons at Rylstone and has returned to Skipton. Only one train can perform a run round movement at Skipton at a time.

5.4 Platform Lengths

The table below shows the maximum length of train that may use each of the platforms at the following passenger stations. All lengths are in metres. The quoted lengths are the usable lengths from ramp to ramp unless specified. The measurements take no account of the need for signal sighting. Trains longer than the quoted lengths will only be accepted subject to the authority of the Route Director.

STATION	PLATFORM	USABLE LENGTH	NOTES
Acklington	Down	114	
Acklington	Up	114	
Adwick	Down	104	
Adwick	Up	104	
Alexandra Palace	Down Hertford	169	
Alexandra Palace	Down Slow	170	
Alexandra Palace	Up Fast	167	
Alexandra Palace	Up Slow	169	
Allens West	Down	122	
Allens West	Up	97	
Alnmouth for Alnwick	Down	233	
Alnmouth for Alnwick	Up	233	
Althorpe	Down	102	
Althorpe	Up	102	
Ancaster	Down	87	
Ancaster	Up	88	
Apperley Bridge	Down	100	
Apperley Bridge	Up	100	
Arlesey	Down	245	
Arlesey	Up	245	
Arram	Down	79	
Arram	Up	81	
Ashwell and Morden	Down	168	
Ashwell and Morden	Up	167	
Baildon	Single	102	
Baldock	Down	168	
Baldock	Up	168	
Bardon Mill	Down	88	
Bardon Mill	Up	91	
Barnetby	Down Fast	116.5	
Barnetby	Down Slow	103.5	
Barnetby	Up Fast	103.5	
Barnetby	Up Slow	116.5	
Barnsley	Down	163	
Barnsley	Up	102	
Barrow Haven	Up	61.5	
Barrow Haven	Down	46	
Barton on Humber	Single	55	
Batley	Down	119	
Batley	Up	126	
Battersby	Single	155	
Bayford	Down	123	
Bayford	Up	122	

STATION	PLATFORM	USABLE LENGTH	NOTES
Bempton	Single – Down	117	
Bempton	Single – Up	93	
Ben Rhydding	Down	99	
Ben Rhydding	Up	99	
Bentley (S Yorkshire)	Down	104	
Bentley (S Yorkshire)	Up	104	
Berry Brow	Single	51	
Berwick upon Tweed	Down	233	
Berwick upon Tweed	Up	234	
Beverley	Down	104	
Beverley	Up	104	
Biggleswade	Down Fast	247	
Biggleswade	Down Slow	247	
Biggleswade	Up Fast	246	
Biggleswade	Up Slow	246	
Billingham	Down	146	
Billingham	Up	146	
Bingley	Down	111	
Bingley	Up	111	
Bishop Auckland	Single	80	
Blaydon	Down	97	
Blaydon	Up	97	
Bolton upon Dearne	Down	96	
Bolton upon Dearne	Up	96	
Boston	Down	173	
Boston	Up	174	
Bottesford	Down	139	
Bottesford	Up	121	
Bowes Park	Down	138	
Bowes Park	Up	138	
Bradford Forster Square	1	273	
Bradford Forster Square	2	266	
Bradford Forster Square	3	101	
Bradford Interchange	1	209	
Bradford Interchange	2	203	
Bradford Interchange	3	119	
Bradford Interchange	4	103	
Bramley	Down	102	
Bramley	Up	102	
Brampton (Cumbria)	Down	106	
Brampton (Cumbria)	Up	107	
Bridlington	4	168	
Bridlington	5	168	
Bridlington	6	138	
Bridlington	7	214	Out of use to passenger trains
Brigg	Down	140	
Brigg	Up	154	
Brighouse	Down	97	
Brighouse	Up	97	
British Steel Redcar	Down	60	
British Steel Redcar	Up	60	
Brockholes	Single	49	
Brockley Whins	Down	65	

STATION	PLATFORM	USABLE LENGTH	NOTES
Brockley Whins	Up	65	
Brookmans Park	Down Fast	123	
Brookmans Park	Down Slow	123	
Brookmans Park	Up Fast	123	
Brookmans Park	Up Slow	123	
Broomfleet	Down	95	
Broomfleet	Up	95	
Brough	Down	184	
Brough	Up	184	
Burley in Wharfedale	Down	98	
Burley in Wharfedale	Up	98	
Burley Park	Down	97	
Burley Park	Up	97	
Castleford	Down	90	
Castleford	Up	97	
Castleton Moor	Single	77	
Cattal	Down	86	
Cattal	Up	86	
Chapelton	Down	85	
Chapelton	Up	85	
Chathill	Down	83	
Chathill	Up	164	
Chester le Street	Down	104	
Chester le Street	Up	104	
Chesterfield	1	212	
Chesterfield	2	204	
Chesterfield	3	240	
Church Fenton	1	101	
Church Fenton	2	132	
Church Fenton	3	132	Down direction
Church Fenton	3	121	Up direction
Church Fenton	4	119	
Cleethorpes	1	202	DMU restricted to 170
Cleethorpes	2	205	DMU restricted to 174
Cleethorpes	3	205	DMU restricted to 174
Cleethorpes	4	203	
Collingham	Down	54	
Collingham	Up	52	
Commondale	Single	51	
Conisbrough	Down	117	
Conisbrough	Up	97	
Cononley	Down	116	
Cononley	Up	95	
Corbridge	Down	97	
Corbridge	Up	100	
Cottingham	Down	108	
Cottingham	Up	108	
Cottingley	Down	85	
Cottingley	Up	85	
Cramlington	Down	101	
Cramlington	Up	101	
Creswell	Down	79	
Creswell	Up	79	

STATION	PLATFORM	USABLE LENGTH	NOTES
Crews Hill	Down	126	
Crews Hill	Up	126	
Cross Gates	1	151	
Cross Gates	2	148	
Crossflatts	Down	102	
Crossflatts	Up	102	
Crowle	Down	90	
Crowle	Up	89	
Cuffley	Down	126	
Cuffley	Up	126	
Danby	Single	90	
Darlington	1	354	Up direction
Darlington	1	347	Down direction to T887 signal
Darlington	2	181	
Darlington	3	200	
Darlington	4	458	Both directions
Darlington	4	238	Up direction to T888 signal
Darlington	4a	134	Down direction to T895 signal
Darlington	4b	251	Down direction clear of 1080B points
Darnall	Down	108	
Darnall	Up	108	
Darton	Down	104	
Darton	Up	104	
Deighton	Down	74	
Deighton	Up	74	
Denby Dale	Single	59	
Dewsbury	Down	150	
Dewsbury	Up	166	
Dinsdale	Down	97	
Dinsdale	Up	97	
Dodworth	Single	95	
Doncaster	0	96	
Doncaster	1	327	Down direction
Doncaster	1	234	Down direction to D1481 Signal
Doncaster	1	318	Up direction to D278 Signal
Doncaster	2	105	
Doncaster	3a	246	Up direction from D292 to D282 Signal
Doncaster	3b	165	
Doncaster	4	299	Down Direction
Doncaster	4	257	Up Direction
Doncaster	5	57	
Doncaster	6	109	
Doncaster	7	105	
Doncaster	8	325	Down Direction
Doncaster	8	285	Up Direction
Dore & Totley	Single	100	
Drayton Park	Down	124	
Drayton Park	Up	124	
Driffield	Down	124	
Driffield	Up	103	
Dronfield	Down	111	
Dronfield	Up	111	
Dunston	Down	85	

STATION	PLATFORM	USABLE LENGTH	NOTES
Dunston	Up	85	
Durham	Down	295	
Durham	Up	264	Network Change NC/G1/2017/LNE/021
Eaglescliffe	Down	208	
Eaglescliffe	Up	190	
East Boldon	Down	65	
East Boldon	Up	65	
East Garforth	Down	102	
East Garforth	Up	102	
Eastrington	Down	90	
Eastrington	Up	90	
Egton	Single	80	
Elsecar	Down	130	
Elsecar	Up	99	
Enfield Chase	Down	126	
Enfield Chase	Up	125	
Essex Road	Down	128	
Essex Road	Up	128	
Featherstone	Down	72	
Featherstone	Up	72	
Fellgate	Down	65	
Fellgate	Up	65	
Ferriby	Down	110	
Ferriby	Up	170	
Filey	Down	119	
Filey	Up	112	
Finsbury Park	1	245	
Finsbury Park	2	245	
Finsbury Park	3	257	To sighting point of K384 signal. Full length 263m
Finsbury Park	4	249	
Finsbury Park	5	246.5	
Finsbury Park	6	178	
Finsbury Park	7	239.5	
Finsbury Park	8	168	
Fitzwilliam	Down	93	
Fitzwilliam	Up	93	
Frizinghall	Down	98	
Frizinghall	Up	98	
Gainsborough Central	Down	138	
Gainsborough Central	Up	138	
Gainsborough Lea Road	Down	145	
Gainsborough Lea Road	Up	144	
Garforth	1	151	
Garforth	2	149	
Gargrave	Down	92.3	
Gargrave	Up	88.8	
Gilberdyke	Down	110	
Gilberdyke	Up	110	
Glaisdale	Down	92	
Glaisdale	Up	86	
Glasshoughton	Down	99	
Glasshoughton	Up	99	

STATION	PLATFORM	USABLE LENGTH	NOTES
Goldthorpe	Down	92	
Goldthorpe	Up	92	
Goole	Down	115	
Goole	Up	104	
Gordon Hill	Bay	122	
Gordon Hill	Down	122	
Gordon Hill	Up	122	
Goxhill	Down	83	
Goxhill	Up	83	
Grange Park	Down	129	
Grange Park	Up	129	
Grantham	1	290	
Grantham	2	289	
Grantham	3	64	Platform 4 side. Additional 31m on Platform 2 side
Grantham	4	249	
Great Ayton	Single	84	
Great Coates	Down	55	
Great Coates	Up	80	
Grimsby Docks	Single	97	
Grimsby Town	1	135	
Grimsby Town	2	137	Down direction
Grimsby Town	2	136	Up direction
Grimsby Town	3	138	
Grosmont	Single	83	
Guiseley	Down	119	
Guiseley	Up	109	
Gypsy Lane	Single	98	81m only in Down direction
Habrough	Down	110	
Habrough	Up	115	
Hadley Wood	Down Fast	126	
Hadley Wood	Down Slow	186	
Hadley Wood	Up Fast	126	
Hadley Wood	Up Slow	186	
Halifax	Down	187	
Halifax	Up	186	
Haltwhistle	Down	97	
Haltwhistle	Up	97	
Hammerton	Down	89	
Hammerton	Up	86	
Harringay	Down	125	
Harringay	Up	126	
Harrogate	1	221	Trains from Leeds, departing in York direction
Harrogate	1	191	To H26 signal. Trains from Leeds or York, departing in Leeds direction
Harrogate	3	243	
Hartlepool	1	136	Down direction
Hartlepool	1	125	Up direction
Hartlepool	2	76	
Hatfield	Down Fast	170	
Hatfield	Down Slow	170	
Hatfield	Up Slow	170	
Hatfield and Stainforth	Down	111	

STATION	PLATFORM	USABLE LENGTH	NOTES
Hatfield and Stainforth	Up	107	
Havenhouse	Down	48	
Havenhouse	Up	34	
Haydon Bridge	Down	108	
Haydon Bridge	Up	110	
Headingley	Down	97	
Headingley	Up	97	
Healing	Down	56	
Healing	Up	56	
Hebden Bridge	Down	110	
Hebden Bridge	Up	109	
Heckington	Down	96	
Heckington	Up	108	
Heighington	Down	103	
Heighington	Up	90	
Hensall	Down	50	
Hensall	Up	50	
Hertford North	1	154	
Hertford North	2	153	
Hertford North	3	145	
Hessle	Down	105	
Hessle	Up	105	
Heworth	Down	120	
Heworth	Up	120	
Hexham	Down	102	
Hexham	Up	102	
Highbury and Islington (Northern City Line)	Down	126	
Highbury and Islington (Northern City Line)	Up	128	
Hitchin	Down	249	
Hitchin	Up	247	
Honley	Single	51	
Hornbeam Park	Down	87	
Hornbeam Park	Up	86	
Hornsey	Down	124	
Hornsey	Up	126	
Horsforth	Down	110	
Horsforth	Up	115	
Howden	Down	123	
Howden	Up	120	
Hubberts Bridge	Down	78	
Hubberts Bridge	Up	39	
Huddersfield	1	180	
Huddersfield	2	52	
Huddersfield	4	213	Down direction
Huddersfield	4	172	Up direction to HU764 signal
Huddersfield	5	39	
Huddersfield	6	73	
Huddersfield	8	147	
Hull	2	180	
Hull	3	175	
Hull	4	175	

STATION	PLATFORM	USABLE LENGTH	NOTES
Hull	5	234	
Hull	6	231	
Hull	7	229	
Hunmanby	Down	92	
Hunmanby	Up	92	
Huntingdon	1	166	
Huntingdon	2	295	
Huntingdon	3	247	
Hutton Cranswick	Down	83	
Hutton Cranswick	Up	60	
Hykeham	Down	78	
Hykeham	Up	80	
Ilkley	1	199	
Ilkley	2	199	
James Cook	Single	102	
Keighley	Down	225	
Keighley	Up	201	
Kildale	Single	38	
Kirk Sandall	Down	104	
Kirk Sandall	Up	104	
Kirkstall Forge	Down	100	
Kirkstall Forge	Up	100	
Kirton Lindsey	Single	129	
Kiveton Bridge	Down	75	
Kiveton Bridge	Up	75	
Kiveton Park	Down	75	
Kiveton Park	Up	74	
Knaresborough	Down	82	
Knaresborough	Up	83	
Knebworth	Down Fast	169	
Knebworth	Down Slow	169	
Knebworth	Up Fast	169	
Knebworth	Up Slow	169	
Knottingley	Down	93	
Knottingley	Up	66	
Langwith Whaley Thorns	Down	79	
Langwith Whaley Thorns	Up	79	
Lealholm	Single	100	
Leeds	1	301	
Leeds	2	236	
Leeds	3	133	
Leeds	4	152	
Leeds	5	201	
Leeds	6	279	
Leeds	7	99	
Leeds	8	337	
Leeds	8ab	161	
Leeds	8cd	156	
Leeds	9	270	
Leeds	9b	101	
Leeds	9cd	149	
Leeds	10	99	
Leeds	11	368	

STATION	PLATFORM	USABLE LENGTH	NOTES
Leeds	11ab	142	
Leeds	11cd	150	
Leeds	12	309	
Leeds	12ab	86	
Leeds	12cd Westbound	144	
Leeds	12cd Eastbound	123	
Leeds	13	105	
Leeds	14	77	
Leeds	15	216	
Leeds	15a	99	
Leeds	15b	99	
Leeds	16	225	
Leeds	16a	103	
Leeds	16b	102	
Leeds	17	105	
Letchworth	Down	184	
Letchworth	Up	184	
Lincoln	1	92	
Lincoln	2	54	
Lincoln	3	144	
Lincoln	4	144	
Lincoln	5	165	
Lockwood	Single	56	
London King's Cross	0	305	Buffer Stop to top of ramp
London King's Cross	1	295	Buffer Stop to K285 signal
London King's Cross	1	298	Buffer Stop to top of ramp
London King's Cross	1	360	Buffer Stop to K287 signal
London King's Cross	2	294	Buffer Stop to top of ramp
London King's Cross	2	294	Buffer Stop to K283 signal
London King's Cross	3	294	Buffer Stop to top of ramp
London King's Cross	3	294	Buffer Stop to K281 signal
London King's Cross	4	292	Buffer Stop to top of ramp
London King's Cross	4	300	Buffer Stop to K279 signal
London King's Cross	5	278	Buffer Stop to top of ramp
London King's Cross	5	285	Buffer Stop to K277 signal
London King's Cross	6	287	Buffer Stop to top of ramp
London King's Cross	6	312	Buffer Stop to K275 signal
London King's Cross	7	287	Buffer Stop to top of ramp
London King's Cross	7	298	Buffer Stop to K273 signal
London King's Cross	8	279	Buffer Stop to K271 signal
London King's Cross	8	279	Buffer Stop to top of ramp
London King's Cross	9	170	Buffer Stop to K269 signal
London King's Cross	9	167	Buffer Stop to top of ramp
London King's Cross	10	174	Buffer Stop to K267 signal
London King's Cross	10	170	Buffer Stop to top of ramp
London King's Cross	11	174	Buffer Stop to K265 signal
London King's Cross	11	170	Buffer Stop to top of ramp
Longbeck	Down	84	
Longbeck	Up	83	
Low Moor	1	96	
Low Moor	2	96	

STATION	PLATFORM	USABLE LENGTH	NOTES
Malton		150	
Manors	Down	84	
Manors	Up	82	
Market Rasen	Down	71	
Market Rasen	Up	74	
Marsden	Down	75	
Marsden	Up	95	
Marsden	Up Passenger Loop	50	
Marske	Down	137	
Marske	Up	134	
Marton	Single	81	
Meadowhall	1	105	
Meadowhall	2	105	
Meadowhall	3	105	
Meadowhall	4	105	
Menston	Down	98	
Menston	Up	98	
Metheringham	Down	57	
Metheringham	Up	57	
MetroCentre	Down	100	
MetroCentre	Up	100	
Mexborough	Down	112	
Mexborough	Up	112	
Micklefield	Down	89	
Micklefield	Up	90	
Middlesbrough	Down	205	
Middlesbrough	Up	201	
Millfield	Down	65	
Millfield	Up	65	
Mirfield	Down Fast	77	
Mirfield	Up Fast	84	
Mirfield	Up Slow	102	
Moorthorpe	Down	110	
Moorthorpe	Up	120	
Morley	Down	103	
Morley	Up	102	
Morpeth	Down	232	
Morpeth	Up	234	
Mytholmroyd	Down	102	
Mytholmroyd	Up	102	
Nafferton	Down	80	
Nafferton	Up	58	
New Barnet	Down Fast	177	
New Barnet	Down Slow	160	
New Barnet	Up Fast	165	
New Barnet	Up Slow	165	
New Clee	Single	144	
New Holland	Single	43	
New Pudsey	Down	122	
New Pudsey	Up	122	
New Southgate	Down Fast	172	
New Southgate	Down Slow	172	

STATION	PLATFORM	USABLE LENGTH	NOTES
New Southgate	Up Fast	172	
New Southgate	Up Slow	172	
Newark Castle	Down	97	
Newark Castle	Down	97	
Newark Castle	Up	66	
Newark Castle	Up	66	
Newark North Gate	Down	255	
Newark North Gate	Passenger Loop	302	Down direction
Newark North Gate	Passenger Loop	238	Up direction
Newark North Gate	Up	255	
Newcastle	1	161	
Newcastle	10	114	
Newcastle	11	106	
Newcastle	12	108	
Newcastle	2	362	
Newcastle	3	304	
Newcastle	4	268	
Newcastle	5	68	
Newcastle	6	97	Platforms 5 and 6 can be combined with a total length of 217m
Newcastle	7	115	
Newcastle	8	41	Platforms 7 and 8 combined with a total length of 209m in Down direction, and 212m in Up direction
Newcastle	9	112	
Newton Aycliffe	Down	59	
Newton Aycliffe	Up	59	
Normanton	Down	77	
Normanton	Up	61	
North Road	Single	60	
Northallerton	Down	261	Network Change NCG12017LNE026
Northallerton	Up	270	
Nunthorpe	Down	86	
Nunthorpe	Up	84	
Oakleigh Park	Down Fast	173	
Oakleigh Park	Down Slow	173	
Oakleigh Park	Up Fast	174	
Oakleigh Park	Up Slow	174	
Old Street	Down	128	
Old Street	Up	128	
Outwood	Down	93	
Outwood	Up	93	
Pallion	Down	65	
Pallion	Up	65	
Palmers Green	Down	127	
Palmers Green	Up	137	
Pannal	Down	91	
Pannal	Up	91	
Park Lane	Down	65	
Park Lane	Up	65	
Pegswood	Down	89	

STATION	PLATFORM	USABLE LENGTH	NOTES
Pegswood	Up	89	
Penistone	Down	102	
Penistone	Up	121	
Peterborough	1	326	No longer a bay platform
Peterborough	2	319	
Peterborough	3	265	
Peterborough	4	265	
Peterborough	5	265	
Peterborough	6	188	
Peterborough	7	188	
Pontefract Baghill	Down	127	
Pontefract Baghill	Up	102	
Pontefract Monkhill	Down	66	
Pontefract Monkhill	Up	76	
Pontefract Tanshelf	Down	72	
Pontefract Tanshelf	Up	72	
Poppleton	Down	84	
Poppleton	Up	84	
Potters Bar	Down Fast	166	
Potters Bar	Down Slow	166	
Potters Bar	Up Fast	164	
Potters Bar	Up Slow	164	
Prudhoe	Down	87	
Prudhoe	Up	95	
Rauceby	Down	91	
Rauceby	Up	91	
Ravensthorpe	Down	85	
Ravensthorpe	Up	85	
Rawcliffe	Single	46	Includes 8m of substandard width
Redcar Central	Down	102	
Redcar Central	Up	128	
Redcar East	Down	84	
Redcar East	Up	83	
Retford	1	255	
Retford	2	253	
Retford	3	135	Low Level Platforms
Retford	4	135	Low Level Platforms
Riding Mill	Down	88	
Riding Mill	Up	100	
Rotherham Central	Down	112	
Rotherham Central	Up	108	
Royston	Down	169	
Royston	Up	236	
Ruskington	Down	57	
Ruskington	Up	57	
Ruswarp	Single	101	Down direction
Ruswarp	Single	80	Up direction
Saltaire	Down	102	
Saltaire	Up	102	
Saltburn	1	156	
Saltburn	2	157	
Saltmarshe	Down	71	
Saltmarshe	Up	71	

STATION	PLATFORM	USABLE LENGTH	NOTES
Sandal and Agbrigg	Down	93	
Sandal and Agbrigg	Up	93	
Sandy	Down Slow	246	
Sandy	Up Slow	246	
Saxilby	Down	107	
Saxilby	Up	97	
Scarborough	1	277	
Scarborough	2	183	
Scarborough	3	163	
Scarborough	4	129	
Scarborough	5	122	
Scunthorpe	Down	143	
Scunthorpe	Up	138	
Seaburn	Down	65	
Seaburn	Up	65	
Seaham	Down	115	
Seaham	Up	115	
Seamer	Down	120	
Seamer	Up	125	
Seaton Carew	Down	125	
Seaton Carew	Up	125	
Selby	Bay Platform	120	
Selby	Down	200	
Selby	Up	257	
Sheffield	1	330	
Sheffield	1a	68	Down direction to S112 signal
Sheffield	1a	68	Up direction to S101 signal
Sheffield	1b	146	Down direction clear of 4060B points
Sheffield	1b	143	Up direction to S116 signal
Sheffield	TL	293	Between S102 and S123, between S102 and S113 64m
Sheffield	DSS	293	
Sheffield	2	345	Down direction to S127 signal
Sheffield	2	329	Up direction to S104 signal
Sheffield	2c	58	54m on east side
Sheffield	3	145	
Sheffield	4	112	
Sheffield	5	326	Down direction
Sheffield	5	237	Up direction to S106 signal
Sheffield	USS1	247	
Sheffield	USS2	247	
Sheffield	6	351	
Sheffield	7	107	135m on east side
Sheffield	8	368	To S139 signal in down direction
Sheffield	8	378	Up direction
Shepley	Down	58	
Shepley	Up	49	
Sherburn in Elmet	Down	77	
Sherburn in Elmet	Up	83	
Shildon	Down	81	
Shildon	Up	105	
Shipley	1	102	
Shipley	2	106	Down direction

STATION	PLATFORM	USABLE LENGTH	NOTES
Shipley	2	115	Up Direction
Shipley	3	240	Down direction
Shipley	3	215	Up Direction
Shipley	4	98	
Shipley	5	98	
Shirebrook	Down	79	
Shirebrook	Up	79	
Shireoaks	Down	97	
Shireoaks	Up	97	
Silkstone Common	Single	102	
Skegness	2	201	
Skegness	3	201	
Skegness	4	245	
Skegness	5	245	
Skegness	6	242	
Skegness	7	242	
Skipton	1	99	
Skipton	2	200	Up direction
Skipton	2	197	Down direction
Skipton	3	183	Down direction
Skipton	3	155	Up direction
Skipton	4	182	Down direction
Skipton	4	154	Up direction
Slaithwaite	Down	60	
Slaithwaite	Up	60	
Sleaford	1	224	
Sleaford	2	186	
Sleaford	3	186	
Sleights	Single	74	
Snaith	Single	42	
South Bank	Down	75	
South Bank	Up	74	
South Elmsall	Down	91	
South Elmsall	Up	91	
South Hylton		130	
South Milford	Down	68	
South Milford	Up	91	
Sowerby Bridge	Down	97	
Sowerby Bridge	Up	102	
Spalding	Down	145	
Spalding	Up	183	
St Neots	Down Fast	249	
St Neots	Down Slow	249	
St Neots	Up Fast	249	
St Neots	Up Slow	249	
St Peters	Down	65	
St Peters	Up	65	
Stadium of Light	Down	65	
Stadium of Light	Up	65	
Stallingborough	Down	85	
Stallingborough	Up	86	
Starbeck	Down	139	
Starbeck	Up	139	

STATION	PLATFORM	USABLE LENGTH	NOTES
Steeton and Silsden	Down	102	
Steeton and Silsden	Up	102	
Stevenage	Down Fast	247	
Stevenage	Down Slow	247	
Stevenage	Up Fast	247	
Stevenage	Up Slow	247	
Stocksfield	Down	109	
Stocksfield	Up	119	
Stocksmoor	Down	66	
Stocksmoor	Up	66	
Stockton	Down	104	
Stockton	Up	104	
Streethouse	Down	72	
Streethouse	Up	72	
Sunderland	1	72	Up direction
Sunderland	1	77	Down direction
Sunderland	2	61	Up direction
Sunderland	2	84	Down direction. Platforms 1 and 2 can be combined with a total length of 179 metres in the Up direction and 206 metres in the Down direction.
Sunderland	3	60	Down and Up directions
Sunderland	4	72	Down direction
Sunderland	4	80	Up direction. Platforms 3 and 4 can be combined with a total length of 174 metres in the Down direction and 177 metres in the Up direction.
Swinderby	Down	75	
Swinderby	Up	60	
Swineshead	Down	94	
Swineshead	Up	89	
Swinton (S Yorkshire)	1	92	
Swinton (S Yorkshire)	2	92	
Swinton (S Yorkshire)	3	92	
Teesside Airport	Down	76	
Teesside Airport	Up	76	
Thirsk	Down	135	
Thirsk	Up	148	
Thornaby	Down	143	
Thornaby	Up	146	
Thorne North	Down	89	
Thorne North	Up	90	
Thorne South	Down	90	
Thorne South	Up	90	
Thornton Abbey	Down	55	
Thornton Abbey	Up	55	
Thorpe Culvert	Down	61	
Thorpe Culvert	Up	62	
Thurnscoe	Down	92	
Thurnscoe	Up	92	
Ulceby	Single	44	
Ulleskelf	Down	106	
Ulleskelf	Up	106	

STATION	PLATFORM	USABLE LENGTH	NOTES
University	Down	65	
University	Up	65	
Wadsley Bridge	Single	111	Out of use
Wainfleet	Down	96	
Wainfleet	Up	96	
Wakefield Kirkgate	1	92	
Wakefield Kirkgate	2	120	
Wakefield Kirkgate	3	103	
Wakefield Westgate	Down	255	
Wakefield Westgate	Up	255	
Watton at Stone	Down	126	
Watton at Stone	Up	126	
Weeton	Down	88	
Weeton	Up	86	
Welham Green	Down	129	
Welham Green	Up	129	
Welwyn Garden City	Down Back	185	
Welwyn Garden City	Down Slow	185	
Welwyn Garden City	Up Back	185	
Welwyn Garden City	Up Slow	185	
Welwyn North	Down	170	
Welwyn North	Up	170	
Wetheral	Down	80	
Wetheral	Up	74	
Whitby	1	177	
Whitby	2	173	
Whitley Bridge	Down	65	
Whitley Bridge	Up	59	
Whitwell	Down	79	
Whitwell	Up	79	
Widdrington	Down	90	
Widdrington	Up	90	
Winchmore Hill	Down	136	
Winchmore Hill	Up	135	
Wombwell	Down	134	
Wombwell	Up	99	
Woodhouse	Down	84	
Woodhouse	Up	84	
Woodlesford	Down	100	
Woodlesford	Up	71	
Worksop	Down	121	
Worksop	Up	113	
Wressle	Down	95	
Wressle	Up	79	
Wylam	Down	92	
Wylam	Up	107	
Yarm	Down	78	
Yarm	Up	78	
York	1	184	
York	10	315	Down direction
York	10	266	Up direction
York	11	329	Down direction
York	11	329	Up direction

STATION	PLATFORM	USABLE LENGTH	NOTES
York	2	169	
York	3	242	Down direction
York	3	272	Up direction
York	4	157	
York	5	391	Down direction
York	5	410	Up direction
York	6	264	
York	7	249	
York	8	138	
York	9	318	Down direction
York	9	375	Up direction

5.4.1 Loop Lengths

The table below shows the maximum length of train that may use each of the loops at the following stations. Loop and Refuge Siding Standage, given in metres / feet or yards / SLU's (1 SLU = 21 feet) (these lengths do NOT take into account defensive driving policy / stand-back from signals). For a loop that is signalled in one direction only, the length quoted will be from the signal at the exit back to the block joint at the entrance to the loop, over which the entire train must have passed before the points forming the connection are free to be put back into their alternative position. For a bi-directionally signalled loop, the length quoted will be the distance from the signal at one exit to the signal at the other exit from the loop. Check Sectional Appendix for locations where standage is not quoted. Access Requests for trains longer than the quoted lengths will only be accepted subject to the authority of the Route Director. See also Section 4.5.

LN101 LONDON KING'S CROSS TO SHAFTHOLME JUNCTION			
LOCATION	DIRECTION	USABLE LENGTH SLU/METRES	NOTES
Claypole	Up	92/588	
Claypole	Down	113 / 723	In Down directions, train in excess of 350 yards (50 SLU) in length are only permitted to stand for a maximum of 15 minutes
Newark Northgate	Up/Down	76/486	Bi-directional
Carlton	Up	118 / 755	
Carlton	Down	118 / 755	
Retford	Up	118 / 755	Up Platform Loop
Ranskill	Up	118 / 755	
Ranskill	Down	118 / 755	
Doncaster G1	G1	65/416	
Doncaster G2	G2	67/435	
Doncaster Down Leeds Goods	Down	52/332	

LN125 HITCHIN CAMBRIDGE JUNCTION TO ROYSTON (INCLUSIVE)			
LOCATION	DIRECTION	USABLE LENGTH SLU/METRES	NOTES
Royston	Down	28 / 181	

LN600 SHAFTHOLME JUNCTION TO RESTON GSP			
LOCATION	DIRECTION	USABLE LENGTH SLU/METRES	NOTES
Darlington UGL	Up	89 / 569	
Darlington DPL	Down	105/672	
Ferryhill UGL	Up	70 / 448	
Durham UPL	Up	88 / 563	
Durham Down Slow	Down	80 / 512	
Low Fell, Down/Up Goods	Down/Up	35 / 224	
Heaton DGL South	Down	117 / 748	
Heaton DGL South + North	Down	383 / 1307	
Heaton UGL	Up	107 / 684	

LN600 SHAFTHOLME JUNCTION TO RESTON GSP			
LOCATION	DIRECTION	USABLE LENGTH SLU/METRES	NOTES
Morpeth UPL	Up	67 / 428	
Chevington DPL	Down	131 / 838	
Chevington UPL	Up	135 / 864	
Wooden Gate DPL	Down	76 / 486	
Wooden Gate DRS	Down	61 / 390	
Wooden Gate UPL	Up	137 / 876	
Crag Mill DPL	Down	160 / 1024	
Crag Mill UPL	Up	170 / 1088	
Tweedmouth No. 1 Reception	Up	60/384	
Berwick-upon-Tweed DGL	Down	119 / 761	
Berwick-upon-Tweed UGL	Up	60 / 384	

5.5 Timing Allowances

All allowances shown are in minutes.

LH/HST/22x	Refers to non-freight locomotive hauled trains and all trains capable of running over 100 mph. Performance allowance does not apply to empty coaching stock moves and freight services
MU/LL	Refers to all forms of multiple unit, whether diesel or electric as well as to light locomotives, not capable of running at over 100 mph. Performance allowance does not apply to light locomotives
CI 4	Refers to locomotive hauled Class 4 freight trains
CI 6	Refers to locomotive hauled Class 6 freight trains

All allowances are indicative for the Final Principal Rules and are subject to change.

SX Daytime allowances apply at all times except where specified differently in Sections 5.5.2, 5.5.3, 5.5.4, 5.5.5 and 5.5.6

E refers to engineering allowance
P refers to performance allowances

5.5.1 SX Daytime (See routes for applicable times)

On Monday different allowances apply on some routes until the end of the 'Sunday' allowances at the times specified in the tables below. Please refer to Section 5.5.4 for the 'Sunday' allowances section to identify the routes to which those allowances apply.

LN101 LONDON KING'S CROSS TO SHAFTHOLME JUNCTION					
TIMING SECTION	TYPE	LH	MU	Freight	REMARKS

LN101 LONDON KING'S CROSS TO SHAFTHOLME JUNCTION					
TIMING SECTION	TYPE	LH	MU	Freight	REMARKS
Down					
Approach Welwyn Garden City	E		1		Applied for trains terminating at Welwyn Garden City Only
Approach Stevenage	P	1	1		
	E				
Approach Holme Jn	E	1	1	1	
Approach Newark Northgate	E	1	1	1	
Approach Loversall Carr Jn	E	1	1	1	
Up					
Approach Doncaster	E	1*	1*	1	*Not required for services that are routed towards Sheffield
Approach Newark F.C.	E	1	1	1	
After Tallington	E	1	1	1	
Approach Welwyn Garden City	P	1	1		
	E			1	
Approach Belle Isle	E	1	1	1	Services routed towards the North London Lines (LN115) are to receive this allowance approaching Copenhagen Jn

LN105 MOORGATE TO FINSBURY PARK JUNCTION					
Timing Section	Type	LH HST EPU CI 4 22X	MU LL	CI 6	Remarks
Up – Weekdays					
Approach Moorgate	E		1		

LN110 CANONBURY WEST JUNCTION TO FINSBURY PARK JUNCTION					
TIMING SECTION	TYPE	LH	MU	Freight	REMARKS
Up					
Approach Highbury Vale Jn	E	1	1	1	

LN120 WOOD GREEN NORTH JUNCTION TO LANGLEY JUNCTION (VIA HERTFORD)					
TIMING SECTION	TYPE	LH	MU	Freight	REMARKS
Down					
Approach Langley Junction	P	1	1*		* Services which Terminate between Alexandra Palace and Stevenage are to receive [1] approaching their terminating location
	E			1	
Up					
Approach Alexandra Palace	P	1	1*		*Allowance of MU only applies to trains originating from North of Stevenage(balances <1> approaching Welwyn Garden City on LN101
	E			1	

LN125 HITCHIN CAMBRIDGE JUNCTION TO ROYSTON (INCLUSIVE)					
TIMING SECTION	TYPE	LH	MU	Freight	REMARKS
Down					
Approach Letchworth/Baldock/Royston	E	1	1	1	Terminating Trains Only

LN170 WERRINGTON JUNCTION TO FLYOVER EAST JUNCTION (VIA LINCOLN)					
Timing Section	Type	LH HST EPU CI 4 22X	MU LL	CI 6	Remarks
Down – Weekdays					
Approach Spalding	E	1	1	1	Terminating trains only
Approach Sleaford	E	2	2	2	
Approach Lincoln	E	1	1	1	
Approach Gainsborough Trent Jn	E	1	1	1	Trains to Doncaster only
Approach Bessacarr Junction	P		2		
	E	2		2	
Up – Weekdays					
Approach Lincoln	E	1	1	1	
	P		2		Trains from Sheffield route direction
Approach Sleaford	E	1	1	1	
Approach Werrington Junction from Sleaford (through trains)	E	2	2	2	
Approach Werrington Junction from Spalding (trains starting from Spalding)	E	1	1	1	

LN185 ALLINGTON WEST JUNCTION TO SKEGNESS					
Timing Section	Type	LH HST EPU CI 4 22X	MU LL	CI 6	Remarks
Down – Weekdays					
Approach Skegness	E	2	2	2	

LN195 GRANTHAM NOTTINGHAM BRANCH JUNCTION TO ALLINGTON WEST JN (INCLUSIVE)					
Timing Section	Type	LH HST EPU CI 4 22X	MU LL	CI 6	Remarks
Down – Weekdays					
Approach Allington West Junction	E	2	2	2	

LN200 WRAWBY JUNCTION TO PELHAM STREET JUNCTION					
Timing Section	Type	LH HST EPU CI 4 22X	MU LL	CI 6	Remarks
Down – Weekdays					
Approach Lincoln	E	2	2	2	

LN206 NEWARK FLAT CROSSING (INCLUSIVE) TO WEST HOLMES JUNCTION					
Timing Section	Type	LH HST EPU CI 4 22X	MU LL	CI 6	Remarks
Down – Weekdays					
Approach Pywipe Junction/Lincoln	E	1	1	1	
Up – Weekdays					
Approach Newark Castle/Newark Flat Crossing East Junction	E	1	1	1	

LN600 SHAFTHOLME JUNCTION TO RESTON GSP					
TIMING SECTION	TYPE	LH	MU	Freight	REMARKS
Down					
Approach Colton Jn	E	1	1	1	
Approach Darlington/Darlington DGL	P	1	1		
	E			1	
Approach Birtley Jn	E	1	1	1	
Approach Berwick	E	1	1	1	Services which Terminate between Newcastle and Berwick are to receive this allowance approaching their terminating location
Up					
Approach Heaton South Jn	E	1	1	1	Services which have originated on Blyth & Tyne routes (LN694/LN702/LN704) do not require this allowance
Approaching Darlington	P	1	1		
	E			1	
Approaching Skelton Jn	E	1	1	1	Services on the SL are to receive this allowance approaching Skelton Bridge Jn

LN626 NORTHALLERTON HIGH JUNCTION TO NORTHALLERTON EAST JUNCTION					
Timing Section	Type	LH HST EPU CI 4 22X	MU LL	CI 6	Remarks
Up					
Approach Northallerton	E	1	1	2	Moved from LN627, no change

LN627 LONGLANDS JUNCTION TO NEWCASTLE EAST JUNCTION VIA THE COAST

TIMING SECTION	TYPE	LH	MU	Freight	REMARKS
Down					
Approach Eaglescliffe	E	1	1	1	For clarity, services from the Darlington direction (LN631) do not require this allowance
Approach Hartlepool	E	1	1		Terminating services only
Approach Sunderland	E	1	1	1	For clarity, services from the South Hylton direction (LN628) do not require this allowance
Approach Pelaw Metro Jn	E		1		Tyne & Wear Metro only
Approach Park Lane Jn	P	1	1		
	E	1	1	2	
Up					
Approach Sunderland	E	1	1*	1	All Northern and TWM terminating services only
Approach Longlands Junction	E	1	1	1	

LN628 SOUTH HYLTON TO SUNDERLAND SOUTH JUNCTION

Timing Section	Type	LH HST EPU CI 4 22X	MU LL	CI 6	Remarks
Up – Weekdays					
Approach South Hylton	E		1		

LN631 DARLINGTON SOUTH JUNCTION TO EAGLESCLIFFE SOUTH JUNCTION

TIMING SECTION	TYPE	LH	MU	Freight	REMARKS
Up					
Approach Darlington	E	1	1	1	

LN632 STOCKTON CUT JUNCTION TO SALTBURN					
Timing Section	Type	LH	MU	Freight	Remarks
Down					
Approach Middlesbrough	E	1	1	1	
Approach Saltburn	E	1	1	1	
Up					
Approach Guisborough Jn	E	1	1	1	

LN634 GUISBOROUGH JUNCTION TO WHITBY					
Timing Section	Type	LH	MU	Freight	Remarks
Down					
Approach Nunthorpe	E	1	1	1	
Approach Whitby	E	1	1	1	
Up					
Approach Guisborough Jn	P	2	2		
	E			2	

LN646 NORTON-ON-TEES SOUTH TO FERRYHILL SOUTH JUNCTION					
Timing Section	Type	LH HST EPU CI 4 22X	MU LL	CI 6	Remarks
Down – Weekdays					
Approach Ferryhill South Junction	E	2	2	2	

LN678 DARLINGTON NORTH JUNCTION TO EASTGATE					
Timing Section	Type	LH HST	MU	CI 6	Remarks
Up – Weekdays					
Approaching Bishop Auckland	P	1	1		
	E	1	1	1	
Approaching Darlington	P	1	1		
	E	1	1	1	

LN682 KING EDWARD BRIDGE SOUTH JUNCTION TO PETTERIL BRIDGE JUNCTION					
Timing Section	Type	LH HST EPU CI 4 22X	MU LL	CI 6	Remarks
Down – Weekdays					

LN682 KING EDWARD BRIDGE SOUTH JUNCTION TO PETTERIL BRIDGE JUNCTION					
Timing Section	Type	LH HST EPU CI 4 22X	MU LL	CI 6	Remarks
Approach Hexham	E		2		Terminating trains only
Approach Petteril Bridge Junction	E	2	2	2	
Up – Weekdays					
Approach Norwood Jn	E	2	2	2	Not for trains starting at Metro Centre

LN694 BENTON NORTH JUNCTION TO MORPETH NORTH JUNCTION VIA BEDLINGTON					
Timing Section	Type	LH HST EPU CI 4 22X	MU LL	CI 6	Remarks
Approach Bedlington	E	2	2	2	From Morpeth direction

LN736 CLEETHORPES TO NUNNERY MAIN LINE JUNCTION VIA RETFORD					
Timing Section	Type	LH HST EPU CI 4 22X	MU LL	CI 6	Remarks
Down – Weekdays					
Approach Retford	E	2	2	2	
Approach Worksop	P		1		
Approach Nunnery Main Line Junction	E	1	1	1	
	P		1½		
Up – Weekdays					
Approach Worksop	E	2	2	2	Terminating trains only
	P		½		Terminating trains only
Approach Retford	E	2	2	2	Terminating trains only
	P		2		Terminating trains only
Approach Clarborough Junction	E	2	2	2	
Approach Marsh Junction/Grimsby Town	E	2	3*	2	* 1 minute from Barton on Humber, 2 minutes from Lincoln
	P		2		Terminating Grimsby Town only
Approach Cleethorpes	P		4*		2 minutes may be shown as advertised differential * For arrivals into Cleethorpes for services from Barton-on-Humber, the value of 1 minute performance should be presentable as either <1> before or as public timetable differential in Cleethorpes arrival.

LN742 KILLINGHOLME JUNCTION TO BROCKLESBY JUNCTION

Timing Section	Type	LH HST EPU CI 4 22X	MU LL	CI 6	Remarks
Down – Weekdays					
Approach Ulceby	E	1		1	
Up – Weekdays					
Approach Humber Rd Junction	E	2		2	

LN752 WRABY JUNCTION TO MARSHGATE JUNCTION

Timing Section	Type	LH HST EPU CI 4 22X	MU LL	CI 6	Remarks
Down – Weekdays					
Approach Scunthorpe	E	1*	1	2	*2 for Class 4
Approach Crowle	E	1*		1	* Class 4 only
Approach Hatfield	E	2*		2	* Class 4 only
Approach Doncaster	E	2	2	2	
	P	3	2*		*1 minute for trains starting at Goole or Scunthorpe
Up – Weekdays					
Approach Scunthorpe	P		1		Terminate only
	E	3*	1 [#]	3	* Class 4 only. # Terminate Only
Approach Wrawby	E	2*		2	* Class 4 only

LN766 BENTLEY JUNCTION TO HEXTHORPE JUNCTION (DONCASTER AVOIDING LINE)

Timing Section	Type	LH HST EPU CI 4 22X	MU LL	CI 6	Remarks
Down – Weekdays					
Approach Hexthorpe Junction	E	1	1	1	
Up – Weekdays					
Approach Bentley Junction	E	1	1	1	

LN804 TAPTON JUNCTION TO GASCOIGNE WOOD JUNCTION VIA SHEFFIELD					
Timing Section	Type	LH HST EPU CI 4 22X	MU LL	CI 6	Remarks
Down – Weekdays					
Approach Dore Station Junction	E	1	1	1	
Approach Milford Junction	E	3	3	2	
Up – Weekdays					
Approach Pontefract Baghill/ Ferrybridge North Junction	E	2	3	2	
Approach Moorthorpe/Moorthorpe Signal L6586	E	3	3	3	
Approach Nunnery Main Line Junction	E	1	1	1	Nil for East Midlands services.
	P	1	1		

LN806 TAPTON JUNCTION TO MASBOROUGH JUNCTION VIA 'OLD ROAD'					
Timing Section	Type	LH HST EPU CI 4 22X	MU LL	CI 6	Remarks
Down – Weekdays					
Approach Masborough Junction	E	2*	2*	2*	*Can be applied approaching Masborough Sorting Sidings South Junction
Up – Weekdays					
Approach Beighton Junction	E	2	2	2	

LN826 DONCASTER SOUTH YORKSHIRE JUNCTION TO SWINTON					
Timing Section	Type	LH HST EPU CI 4 22X	MU LL	CI 6	Remarks
Up – Weekdays					
Approach Doncaster	E	1	1	1	Nil for East Midlands services.
	P	1*	1*		

LN830 ALDWARKE JUNCTION TO WOODBURN JUNCTION					
Timing Section	Type	LH HST EPU CI 4 22X	MU LL	CI 6	Remarks
Up – Weekdays					
Approach Rotherham Central	E	1½	1½*	2	*Nil for Supertram

LN836 DONCASTER MARSHGATE JUNCTION TO NEVILLE HILL EAST JUNCTION					
Timing Section	Type	LH	MU	Freight	Remarks
Down					
Approach Adwick	E		1		Terminating trains only
Approach Holbeck Junction/ Copley Hill West Junction	E	1	1	1	
	P	1*	1*		*Does not apply to Virgin Trains East Coast Services
Up					
Approach Neville Hill West Jn	P	1	1		
	E			1	
Approach Doncaster	E	1	1	1	

LN838 LEEDS ARMLEY JUNCTION TO YORK SKELTON JUNCTION VIA HARROGATE					
Timing Section	Type	LH HST EPU CI 4 22X	MU LL	CI 6	Remarks
Down (Leeds to Harrogate) – Weekdays					
Approach Harrogate	E	2	2		Terminating trains only
	P		1		Terminating trains only
Up (Harrogate to Leeds) – Weekdays					
Approach Armley Junction	E	2	2		
	P		2		
Up (Harrogate to York) – Weekdays					
Approach Knaresborough	E		2		Terminating trains only
	P		1		Terminating trains only
Approach York	P		2		Can be located approaching Skelton Junc to aid planning
	E		2		Can be located approaching Skelton Junc to aid planning

LN842 THORPE MARSH JUNCTION TO ADWICK JUNCTION					
Timing Section	Type	LH HST EPU CI 4 22X	MU LL	CI 6	Remarks
Down – Weekdays					
Approach Applehurst Junction	E	3	3	3	

LN852 HOLBECK JUNCTION TO BRADFORD INTERCHANGE

Timing Section	Type	LH HST EPU CI 4 22X	MU LL	CI 6	Remarks
Up – Weekdays					
Approach Holbeck Junction	P		2		1 minute for trains from Halifax, Hebden Bridge or Huddersfield.

LN854 HALL ROYD JUNCTION TO COLTON JUNCTION

Timing Section	Type	LH	MU	Freight	Remarks
Down – Weekdays					
Approach Bradley Wood Junction	E		1		Trains to Huddersfield only
Approach Healey Mills/Horbury Junction	E	2	1	2*	*1 minute for Class 0 services
Approach Horbury Junction	P		1		Trains from Huddersfield terminating at Wakefield.
Approach Castleford	E			1	From Normanton direction only.
Approach Miford	E	2	2	2	
Approach Colton Junction	P	1	1		
Up – Weekdays					
Approach Brighouse	E		1		Terminating trains only
Approach Castleford	E	1	1	1	

LN858 MILNER ROYD JUNCTION TO BRADFORD MILL LANE JUNCTION

Timing Section	Type	LH HST EPU CI 4 22X	MU LL	CI 6	Remarks
Down – Weekdays					
West of Halifax	E		1*		* Not trains starting from Hebden Bridge or Huddersfield
Approach Mill Lane Junction	E	2	1		
Up – Weekdays					
Approach Halifax	P		1		Terminating trains and trains to Huddersfield only

LN860 DIGGLE JUNCTION TO COPLEY HILL EAST JUNCTION

Timing Section	Type	LH HST EPU CI 4 22X	MU LL	CI 6	Remarks
Down – Weekdays					
Approach Huddersfield	E		1		Terminating trains only
	P		1*		Terminating trains only <i>*Does not apply to TPE services</i>
Approach Whitehall Junction	E	2	2*	2	* 1 stopping all stations
	P		1*		* Applies to stopping services services only.
Up – Weekdays					
Approach Heaton Lodge Junction	E		1		Stopping services from Leeds and Wakefield
	P		1		Stopping services from Leeds and Wakefield

LN862 BARNSELY STATION JUNCTION TO HUDDERSFIELD

Timing Section	Type	LH HST EPU CI 4 22X	MU LL	CI 6	Remarks
Down – Weekdays					
Approach Penistone	P		1		
Approach Huddersfield	E	1	1		
	P		½		
Up – Weekdays					
Approach Barnsley	E	1	1		
	P		1		

LN868 WINCOBANK JUNCTION TO HORBURY JUNCTION VIA BARNSELY

Timing Section	Type	LH HST EPU CI 4 22X	MU LL	CI 6	Remarks
Down – Weekdays					
Approach Barnsley	E	1		1	
Up – Weekdays					
Approach Barnsley	P		1		Trains starting from Leeds only
Approach Wincobank Junction	E	1		1	

LN872 ALTOFTS JUNCTION TO LEEDS WEST JUNCTION

Timing Section	Type	LH HST EPU CI 4 22X	MU LL	CI 6	Remarks
Down – Weekdays					
Approach Engine Shed Junction	E	2	2*	2	Approaching Stourton for trains that terminate or call * 1 minute for trains from Knottingley direction
	P		2		

LN880 YORK TO SCARBOROUGH

Timing Section	Type	LH HST EPU CI 4 22X	MU LL	CI 6	Remarks
Down – Weekdays					
Approach Malton	E	1	1	1	
Approach Scarborough	P	3	1		
Up – Weekdays					
Approach Malton	P		1		
Approach York	P	2			
	E	1	1	1	

LN882 WAKEFIELD KIRKGATE WEST JUNCTION TO GOOLE POTTER'S GRANGE JUNCTION

Timing Section	Type	LH HST EPU CI 4 22X	MU LL	CI 6	Remarks
Down – Weekdays					
Approach Pontefract	E		1*		* Trains terminating from Wakefield direction
	P		1*		
Approach Knottingley	E	1	1	1	
	P		1		
Approach Goole	P		2		
Up – Weekdays					
Approach Knottingley	P		1		
Approach Wakefield Kirkgate	E		1		
	P		1		

LN898 NEVILLE HILL EAST JUNCTION TO HULL					
Timing Section	Type	LH	MU	Freight	Remarks
Down					
Approach Selby	P	1	1		Terminating Services Only
	E	1	1	1	
Approach Gilberdyke	P	1*	1*		*TPE and Northern Services Only
Approach Hessle Road Jn	E	1	1	1	
Up					
Approach Selby	E	1	1	1	
Approach Gascoigne Wood Jn	E	1	1	1	

LN910 TEMPLE HIRST JUNCTION TO SELBY SOUTH JUNCTION					
Timing Section	Type	LH	MU	Freight	Remarks
Down					
Approach Selby	E	1	1	1	

LN912 THORNE JUNCTION TO GILBERDYKE JUNCTION					
Timing Section	Type	LH HST EPU CI 4 22X	MU LL	CI 6	Remarks
Down – Weekdays					
Approaching Gilberdyke	P	1	1		
Approach Goole	P		1		Terminating trains only

LN914 HULL TO SEAMER WEST JUNCTION					
Timing Section	Type	LH HST EPU CI 4 22X	MU LL	CI 6	Remarks
Down – Weekdays					
Approach Bridlington	E	2	2		Terminating trains only
	P		1		
Approach Seamer	E	2	2*		* Not trains starting Filey and continuing to York or beyond
Up – Weekdays					
Approach Bridlington	P		1		
Approach Hull	E	2	2*		* 1 minute starting Beverley
	P		1		

LN922 WHITEHALL WEST JUNCTION TO HELLIFIELD SOUTH JUNCTION					
Timing Section	Type	LH HST EPU CI 4 22X	MU LL	CI 6	Remarks
Down – Weekdays					
Approach Skipton	E	2	1*	2	* 2 minutes for DMU
	P		1		Terminating trains only
Up – Weekdays					
Approach Skipton	E	2	2	2	
	P		1		
Approach Armley Junction	E	2	1*	2	* 2 minutes for DMU
	P		1*		* 2 minutes for trains from north of Skipton

LN924 APPERLEY JUNCTION TO ILKLEY					
Timing Section	Type	LH HST EPU CI 4 22X	MU LL	CI 6	Remarks
Down – Weekdays					
Approach Ilkley	E		1		
	P		1		

LN928 SHIPLEY EAST JUNCTION TO BRADFORD FORSTER					
Timing Section	Type	LH HST EPU CI 4 22X	MU LL	CI 6	Remarks
Down – Weekdays					
Approach Bradford Forster Square	E	2	1*	2	* 2 minutes for DMU
	P		1		

LN3214 BELLE ISLE TO CANAL TUNNEL JUNCTION					
Timing Section	Type	LH	MU	Freight	Remarks
Approaching St Pancras Low Level	P		4		All Up Thameslink Trains
Approaching Belle Isle	P		4		All Down Thameslink Trains
For Route LN3214 Please See East Midlands Timetable Planning Rules					

5.5.2 SX Night time (See routes for applicable times)

SX daytime allowances apply to those routes excluded from this section

LN101 LONDON KING'S CROSS TO SHAFTHOLME JUNCTION					
Timing Section	Type	LH HST EPU CI 4 22X	MU LL	CI 6, 7 & 8	Remarks
Additional Engineering Allowance					
Down and Up – Monday night/Tuesday morning to Fridaynight/Saturday morning					
King's Cross – Hitchin Cambridge Jn	E	3	3	3	00:01 TWThF – 05:45 TWThF All trains to be timed over the Slow lines with [3] approaching Holloway in the Up and Hitchin in the Down.
Hitchin Cambridge Jn to Peterborough	E	10*	10*	10*	23:00 MTWTh – 06:00 TWThF All trains over the Fast to be timed with [10] approaching Hitchin Cambridge Jn in the Up and Fletton Jn in the Down * SL Trains timed over the Slows to be timed with [3] approaching Cambridge Jn in the Up and Fletton Jn in the Down.
Peterborough – Stoke	E	2	2	2	2300 - 0530 MX Down. All trains to be timed Slow line 2300 - 0530 MX Up. All trains to be timed Slow line
Stoke - Grantham	E	20	20	20	0105 MX – 0520 MX. All trains to be timed Slow line (B)
Grantham - Newark	E	20	20	20	0115 MX – 0530 MX. All trains to be timed Slow line (B)
Newark - Loversall Carr Junction	E	20	20	20	0130 MX – 0530 MX. All trains to be timed Slow line (B)
Loversall Carr Junction – Doncaster	E	5*	5*	5*	2250 SX – 0530MX
(A) Only one allowance per train between King's Cross and Hitchin					
(B) Only one allowance per train between Stoke Jn – Loversall Carr Jn. To commence on the Down after the passage of 1D36 King's Cross – Leeds and finish before the passage of 1A01 Leeds – King's Cross. No other train should be timed to pass these services within SLW times.					
* 3 mins trains timed SL/GL					

LN600 SHAFTHOLME JUNCTION TO RESTON GSP					
Timing Section	Type	LH HST EPU CI 4 22X	MU LL	CI 6, 7 & 8	Remarks
Additional Engineering Allowance					
Down and Up – Monday night/Tuesday morning to Friday night/Saturday morning					
Doncaster – Colton Junction					NIL
Colton Junction – York	E	3	3	3	2235 SX – 0550 MX. To be coordinated with Church Fenton – Colton Jn. Only one allowance Church Fenton – York.
York – Skelton Junction	E	3	3	3	0030 MX – 0545 MX
Longlands Junction – Darlington South Junction	E	15	15	15	2300 SX – 0530 MX (B)
	E	2			Diverted Sleeper Services Only
Darlington South Junction – Tursdale Junction	E	15	15	15	2300 SX – 0530 MX (B)
	E	2			Diverted Sleeper Services Only
Tursdale Junction – Durham	E	15	15	15	2300 SX – 0530 MX (B)
	E	2			Diverted Sleeper Services Only
Durham – King Edward Bridge	E	15	15	15	2310 SX – 0520 MX (B)
	E	2			Diverted Sleeper Services Only
King Edward Bridge – Newcastle Newcastle – Heaton South Junction	E	2	2	2	2240 SX – 2335 SX (D) All FL trains to be timed over same line 2335 SX – 0525 MX (D) All trains to be timed over one line
	E	2	2	2	2330 SX – 0500 MX (D) All trains to be timed over one line
Heaton South Jn – Alnmouth	E	10	10	25	2305 SX – 0600 MX (C)
Alnmouth – Berwick	E	10	10	25	2305 SX – 0600 MX (C)
Berwick – Signals EG 402/3	E	10	10	25	2305 SX – 0600 MX (C)
A – Only one allowance per train between Stoke Junction and Loversall Carr Junction, to finish before the passage of 1A01 0505 Leeds – King's Cross. No other train should be timed to pass these services within SLW times					
B – Maximum 17 minutes allowance per train between Longlands Jn. and King Edward Bridge					
C – Refer to ECML Route Strategy in Rules of the Route. Only one allowance per train between Heaton South Junction and Monktonhall Jn. This allowance to be utilised in conjunction with Scotland allowances EG402/3 to Monktonhall Jn to allow for all combinations of possessions.					
D – only one allowance per train King Edward Bridge to Heaton South Jn					

LN784 HIGH MARNHAM TO SHIREBROOK EAST JUNCTION

Timing Section	Type	LH HST EPU CI 4 22X	MU LL	CI 6, 7 & 8	Remarks
Additional Engineering Allowance Down and Up – Weekdays					
Boughton Junction – Shirebrook Junctions	E	2	2	2	2200 SX – 0600 MX. Single Line Working. All trains to be timed over same line.

LN854 HALL ROYD JUNCTION TO COLTON JUNCTION

Down and Up – Monday night/Tuesday morning to Friday night/Saturday morning					
Timing Section	Type	LH HST EPU CI 4 22X	MU LL	CI 6, 7 & 8	Remarks
Church Fenton – Colton Junction	E	3	3	3	2300 SX – 0600 MX. To be coordinated with Colton Jn – York. Only one allowance between Church Fenton and York
Horbury Junction – Wakefield Kirkgate	E	3	3	3	2200 SX – 0600 MX

5.5.3 SO Daytime (See routes for applicable times)

The values shown in SX Daytime apply to SO Daytime

5.5.4 SO Nighttime (See routes for applicable times)

SX daytime allowances apply to those routes excluded from this section

LN101 LONDON KING'S CROSS TO SHAFTHOLME JUNCTION					
Timing Section	Type	LH HST EPU CI 4 22X	MU LL	CI 6, 7 & 8	Remarks
Additional Engineering Allowance Down and Up – Saturday night/Sunday morning					
London King's Cross to Hitchin Cambridge Jn	E	3	3	3	23:50 SO – 07:50 Sun All trains to be timed over the Slow Lines with an additional [3] approaching Holloway in the Up and Hitchin in the Down
Hitchin Cambridge Jn to Peterborough	E	10*	10*	10*	23:50 SO – 07:50 Sun All trains over the Fast to be timed with an additional [10] approaching Hitchin Cambridge Jn in the Up and Fletton Jn in the Down. * 3 Trains timed SL All trains over the Slows to be timed with an additional [3] approaching Hitchin Cambridge Jn in the Up and Fletton Jn in the Down.

LN600 SHAFTHOLME JUNCTION TO RESTON GSP					
Timing Section	Type	LH HST EPU CI 4 22X	MU LL	CI 6, 7 & 8	Remarks
Additional Engineering Allowance Down and Up – Saturday night/Sunday morning					
Colton Junction – York	E	3	3	3	2300 Sat – 0800 Sun. To be coordinated with Church Fenton – Colton Jn. Only one allowance Church Fenton – York
Newcastle – Heaton South Junction	E	2	2	2	2145 Sat – 1000 Sun All trains to be timed over the same line

LN854 HALL ROYD JUNCTION TO COLTON JUNCTION					
Timing Section	Type	LH HST EPU CI 4 22X	MU LL	CI 6, 7 & 8	Remarks
Additional Engineering Allowance Down and Up Saturday night/Sunday morning					
Church Fenton – Colton Jn	E	3	3	3	2330 Sat – 0830 Sun. To be coordinated with Colton Jn – York. One allowance only between Church Fenton and York.

5.5.5 SUNDAY Daytime (See routes for applicable times)

SX daytime allowances apply to those routes excluded from this section

LN105 MOORGATE TO FINSBURY PARK JUNCTION					
Timing Section	Type	LH HST EPU CI 4 22X	MU LL	CI 6	Remarks
Up – Sundays					
Approach Moorgate	E		1		

LN170 WERRINGTON JUNCTION TO FLYOVER EAST JUNCTION (VIA LINCOLN)					
Timing Section	Type	LH HST EPU CI 4 22X	MU LL	CI 6	Remarks
Down – Sundays					
Approach Spalding	E	1	1	1	Terminating trains only
Approach Sleaford	E	2	2	2	
Approach Lincoln	E	1	1	1	
Approach Gainsborough Trent Junction	E	1	1	1	Trains to Doncaster only
Approach Bessacarr Junction	P		2		
Up – Sundays					
Approach Lincoln	E	1	1	1	
	P		2		Trains from Sheffield direction only
Approach Sleaford	E	1	1	1	
Approach Werrington Junction from Sleaford (through trains)	E	2	2	2	
Approach Werrington Junction from Spalding (trains starting from Spalding)	E	1	1	1	

LN185 ALLINGTON WEST JUNCTION TO SKEGNESS					
Timing Section	Type	LH HST EPU CI 4 22X	MU LL	CI 6	Remarks
Down – Sundays					
Approach Skegness	E	2	2	2	

LN195 GRANTHAM NOTTINGHAM BRANCH JUNCTION TO ALLINGTON WEST JN (INCLUSIVE)					
Timing Section	Type	LH HST EPU CI 4 22X	MU LL	CI 6	Remarks
Down – Sundays					
Approach Allington West Junction	E	2	2	2	

LN200 WRAWBY JUNCTION TO PELHAM STREET JUNCTION					
Timing Section	Type	LH HST EPU CI 4 22X	MU LL	CI 6	Remarks
Down – Sundays					
Approach Lincoln	E	2	2	2	

LN206 NEWARK FLAT CROSSING (INCLUSIVE) TO WEST HOLMES JUNCTION					
Timing Section	Type	LH HST EPU CI 4 22X	MU LL	CI 6	Remarks
Down – Sundays					
Approach Pyewipe Junction/Lincoln	E	1	1	1	
	P		1		
Up – Sundays					
Approach Newark Castle/Newark Flat Crossing East Junction	E	1	1	1	
	P		1		

LN627 LONGLANDS JUNCTION TO NEWCASTLE EAST JUNCTION VIA THE COAST					
Timing Section	Type	LH HST EPU CI 4 22X	MU LL	CI 6	Remarks
Up – Sunday					
Approach Sunderland	E		1		All Northern and TWM terminating services only

LN628 SOUTH HYLTON TO SUNDERLAND SOUTH JUNCTION					
Timing Section	Type	LH HST EPU CI 4 22X	MU LL	CI 6	Remarks
Up – Sunday					
Approach South Hylton	E		1		

LN646 NORTON-ON-TEES SOUTH TO FERRYHILL SOUTH JUNCTION					
Timing Section	Type	LH HST EPU CI 4 22X	MU LL	CI 6	Remarks
Down – Sundays					
Approach Ferryhill South Junction	E	2	2	2	

LN736 CLEETHORPES TO NUNNERY MAIN LINE JUNCTION VIA RETFORD					
Timing Section	Type	LH HST EPU CI 4 22X	MU LL	CI 6	Remarks
Down – Sundays					
Approach Retford	E	2	2	2	
Approach Worksop	P		1		
Approach Nunnery Main Line Junction	E	1	1	1	
	P		1½		
Up – Sundays					
Approach Worksop	E	2	2	2	Terminating trains only
	P		½		Terminating trains only
Approach Retford	E	2	2	2	Terminating trains only
	P		2		Terminating trains only
Approach Clarborough Junction	E	2	2	2	
Approach Marsh Jn/Grimsby Town	E	2	3*	2	*1 minute for trains from Barton on Humber, 2 from Lincoln
	P		2		Nil for trains from Barton on Humber
Approach Cleethorpes	P		2*		*For arrivals into Cleethorpes for services from Barton-on-Humber, the value of 1 minute performance should be presentable as either <1> before or as public timetable differential in Cleethorpes arrival.

LN752 WRABBY JUNCTION TO MARSHGATE JUNCTION

Timing Section	Type	LH HST EPU CI 4 22X	MU LL	CI 6	Remarks
Down – Sundays					
Approach Scunthorpe	E	1*	1	2	* 2 minutes for Class 4
Approach Crowle	E	1*		1	* Class 4 only
Approach Hatfield	E	2*		2	* Class 4 only
Approach Doncaster	E	2	2	2	
	P	3	2*		*1 minute for trains starting at Goole or Scunthorpe
Up – Sundays					
Approach Scunthorpe	P		1		Terminating trains only
	E	3*	1#	3	* Class 4 only # Terminate only
Approach Wrawby Junction	E	2*		2	* Class 4 only

LN758 BRANCLIFFE EAST JUNCTION TO KIRK SANDALL JUNCTION

Timing Section	Type	LH HST EPU CI 4 22X	MU LL	CI 6	Remarks
Down – Sundays					
Approach St. Catherine's Jn	E	15	15	15	Applies only to the first train on the route.
Up – Sundays					
Approach Brancliffe Jn	E	15	15	15	Applies only to the first train on the route.

LN766 BENTLEY JUNCTION TO HEXTHORPE JUNCTION (DONCASTER AVOIDING LINE)

Timing Section	Type	LH HST EPU CI 4 22X	MU LL	CI 6	Remarks
Down – Sundays					
Approach Hexthorpe Junction	E	1	1	1	
Up – Sundays					
Approach Bentley Junction	E	1	1	1	

LN804 TAPTON JUNCTION TO GASCOIGNE WOOD JUNCTION VIA SHEFFIELD

Timing Section	Type	LH HST EPU CI 4 22X	MU LL	CI 6	Remarks
Down – Sundays					
Approach Dore Station Junction	E	2	2*	2	* 1 minute for trains starting at Chesterfield
Approach Milford Junction	E	3	3	2	
Up – Sundays					
Approach Pontefract Baghill/Ferrybridge North Junction	E	2	3	2	
Approach Moorthorpe/Moorthorpe Signal L6586	E	3	3	3	
Approach Nunnery Main Line Junction	E	2	1	2	
	P	1*	1		*Nil for East Midlands services.

LN806 TAPTON JUNCTION TO MASBOROUGH JUNCTION VIA 'OLD ROAD'

Timing Section	Type	LH HST EPU CI 4 22X	MU LL	CI 6	Remarks
Down – Sundays					
Approach Masborough Junction	E	2	2	2	
Up – Sundays					
Approach Beighton Junction	E	2	2	2	

LN826 DONCASTER SOUTH YORKSHIRE JUNCTION TO SWINTON

Timing Section	Type	LH HST EPU CI 4 22X	MU LL	CI 6	Remarks
Up – Sundays					
Approach Doncaster	E	2	1	2	
	P	1	1		*Nil for East Midlands services.

LN838 LEEDS ARMLEY JUNCTION TO YORK SKELTON JUNCTION VIA HARROGATE

Timing Section	Type	LH HST EPU CI 4 22X	MU LL	CI 6	Remarks
Up (Harrogate to York) – Sundays					
Approach Knaresborough	E		2		Terminating trains only
	P		1		Terminating trains only
Approach York	P		2		Can be located approaching Skelton Junc to aid planning
	E		2		Can be located at any point between Starbeck and York to aid planning

Down (Leeds to Harrogate)– Sundays					
Approach Harrogate	E	2	2		Terminating trains only
	P		1		Terminating trains only
Up (Harrogate to Leeds) – Sundays					
Approach Armley Junction	E	2	2		
	P		2		

LN842 THORPE MARSH JUNCTION TO ADWICK JUNCTION					
Timing Section	Type	LH HST EPU CI 4 22X	MU LL	CI 6	Remarks
Down – Sundays					
Approach Applehurst Junction	E	3	3	3	

LN852 HOLBECK JUNCTION TO BRADFORD INTERCHANGE					
Timing Section	Type	LH HST EPU CI 4 22X	MU LL	CI 6	Remarks
Up – Sundays					
Approach Holbeck Junction	P		2*		* 1 minute for trains from Halifax, Hebden Bridge or Huddersfield.

LN860 DIGGLE JUNCTION TO COPLEY HILL EAST JUNCTION					
Timing Section	Type	LH HST EPU CI 4 22X	MU LL	CI 6	Remarks
Down – Sundays					
Approach Huddersfield	E		1		Terminating trains only
	P		1		Terminating trains only
Up – Sundays					
Approach Huddersfield/Marsden	E		1		Terminating trains only
Approach Heaton Lodge Junction	P		1		Stopping services from Leeds direction

LN862 BARNSELY STATION JUNCTION TO HUDDERSFIELD

Timing Section	Type	LH HST EPU CI 4 22X	MU LL	CI 6	Remarks
Down – Sundays					
Approach Penistone	P		1		
Approach Huddersfield	E	1	1		
	P		½		
Up – Sundays					
Approach Barnsley	E	1	1		
	P		1		

LN868 WINCOBANK JUNCTION TO HORBURY JUNCTION VIA BARNSELY

Timing Section	Type	LH HST EPU CI 4 22X	MU LL	CI 6	Remarks
Down – Sundays					
Approach Barnsley	E	1		1	
Up – Sundays					
Approach Barnsley	P		1		Trains starting from Leeds only
Approach Wincobank Junction	E	1		1	

LN872 ALTOFTS JUNCTION TO LEEDS WEST JUNCTION

Timing Section	Type	LH HST EPU CI 4 22X	MU LL	CI 6	Remarks
Down – Sundays					
Approach Engine Shed Junction	E	2	2*	2	Approaching Stourton for trains that terminate or call * 1 minute for trains from Knottingley direction
	P		2		

LN882 WAKEFIELD KIRKGATE WEST JUNCTION TO GOOLE POTTER'S GRANGE JUNCTION					
Timing Section	Type	LH HST EPU CI 4 22X	MU LL	CI 6	Remarks
Down – Sundays					
Approach Pontefract	E		1*		* Trains terminating from Wakefield direction
	P		1*		* Trains terminating from Wakefield direction
Approach Knottingley	E	1	1	1	
	P		1		
Approach Goole	P		2		
Up – Sundays					
Approach Knottingley	P		1		
Approach Wakefield Kirkgate	E		1		
	P		1		

LN912 THORNE JUNCTION TO GILBERDYKE JUNCTION					
Timing Section	Type	LH HST EPU CI 4 22X	MU LL	CI 6	Remarks
Down – Sundays					
Approaching Gilberdyke	P	1	1		
Approach Goole	P		1		Terminating trains only

LN914 HULL TO SEAMER WEST JUNCTION					
Timing Section	Type	LH HST EPU CI 4 22X	MU LL	CI 6	Remarks
Down – Sundays					
Approach Bridlington	E	2	2		Terminating trains only
	P		1		
Approach Seamer	E	2	2*		* Does not apply to trains starting from Filey and continuing to York or beyond
Up – Sundays					
Approach Bridlington	P		1		
Approach Hull	E	2	2*		* 1 minute for trains starting from Beverley
	P		1		

5.5.6 Sunday Night time (See routes for applicable times)

SX daytime allowances apply to those routes excluded from this section

LN101 LONDON KING'S CROSS TO SHAFTHOLME JUNCTION					
Timing Section	Type	LH HST EPU CI 4 22X	MU LL	CI 6, 7 & 8	Remarks
Additional Engineering Allowance Down and Up – Sunday night/Monday morning					
King's Cross – Hitchin Cambridge Jn	E	3	3	3	00:01 M – 05:45 M All trains to be timed over the Slow lines with an additional [3] approaching Holloway in the Up and Hitchin in the Down.
Hitchin Cambridge Jn to Peterborough	E	10*	10*	10*	23:00 Su – 06:00 M All trains over the Fast to be timed with an additional [10] approaching Hitchin Cambridge Jn in the Up and Fletton Jn in the Down * 3 SL Trains timed over the Slows to be timed with an additional [3] approaching Cambridge Jn in the Up and Fletton Jn in the Down.
Peterborough – Stoke	E	2	2	2	23:10 Su – 05:30 MO Down. All trains to be timed Slow line 23:10 – 05:30 MO Up. All trains to be timed Slow line
* 3 mins trains timed SL/GL					

LN600 SHAFTHOLME JUNCTION TO RESTON GSP

Timing Section	Type	LH HST EPU CI 4 22X	MU LL	CI 6, 7 & 8	Remarks
Additional Engineering Allowance Down and Up – Sunday night/Monday morning					
Loversall Carr Junction – Doncaster	E	5*	5*	5*	2230 Sun – 0530 Mon * 3 for trains timed SL/GL
Colton Junction – York	E	3	3	3	2200 Sun – 0550 Mon (A)
York – Skelton Junction	E	2	2	2	2240 Sun – 0545 Mon all trains to be timed over same line
Skelton Junction – Longlands Junction	E	2	2	2	2130 Sun – 0555 Mon all trains to be timed to run Slow line
Longlands Junction – Darlington South Junction	E	15	15	15	2145 Sun – 0545 Mon (B)
Darlington South Jn – Tursdale Jn	E	15	15	15	2230 Sun – 0545 Mon (B)
Tursdale Junction – Durham	E	15	15	15	2235 Sun – 0525 Mon (B)
Durham – King Edward Bridge	E	15	15	15	2230 Sun – 0525 Mon (B)
King Edward Bridge – Newcastle	E	2	2	2	2240 Sun – 2335 Sun All FL trains to be timed over the same line (C) 2335 Sun – 0525 Mon All trains to be timed over same line (C)
Newcastle to Heaton South Jn	E	2	2	2	2245 Sun – 0500 Mon All trains to be timed over same line (C)
(A) To be coordinated with Church Fenton – Colton. Only one allowance between Church Fenton and York					
(B) Only one allowance per train between Longlands and King Edward Bridge South					
(C) Only one allowance between KEB and Heaton South Junction					

LN752 WRABBY JUNCTION TO MARSHGATE JUNCTION

Timing Section	Type	LH HST EPU CI 4 22X	MU LL	CI 6, 7 & 8	Remarks
Additional Engineering Allowance Down and Up – Sunday night/Monday morning					
Wrawby Junction – Thorne Junction	E	2	2	2	2340 Sun – 0530 Mon.
Thorne Jn – Kirk Sandall Jn	E	2	2	2	2345 Sun – 0445 Mon all trains to be timed via slow lines

LN784 HIGH MARNHAM TO SHIREBROOK EAST JUNCTION

Timing Section	Type	LH HST EPU CI 4 22X	MU LL	CI 6, 7 & 8	Remarks
Additional Engineering Allowance Down and Up – Sunday night/Monday morning					
Boughton Junction – Shirebrook Junctions	E	2	2	2	2200 Sun – 0600 Mon. Single Line Working. All trains to be timed over same line

LN854 HALL ROYD JUNCTION TO COLTON JUNCTION

Timing Section	Type	LH HST EPU CI 4 22X	MU LL	CI 6, 7 & 8	Remarks
Additional Engineering Allowance Down and Up Sunday night/Monday morning					
Heaton Lodge Jn – Thornhill LNW Jn					0015 Mon – 0530 Mon Up trains to be timed on Slow line
Horbury Junction – Wakefield Kirkgate	E	3	3	3	0830 Sun – 0600 Mon
Church Fenton – Colton Jn	E	3	3	3	2300 Sun – 0600 Mon. To be coordinated with Colton Jn – York. One allowance only between Church Fenton and York

LN922 WHITEHALL WEST JUNCTION TO HELLIFIELD SOUTH JUNCTION

Timing Section	Type	LH HST EPU CI 4 22X	MU LL	CI 6, 7 & 8	Remarks
Additional Engineering Allowance Down and Up – Sunday night/Monday morning					
Shipley East Junction – Skipton	E	20	20	20	0001 Mon – 0515 Mon (A)
Skipton – Hellifield	E	20	20	20	2145 Sun – 0530 Mon (A)
(A) Only one allowance per train between Kirkstall Junction and Hellifield, to be co-ordinated with LNW allowances. Refer to Section 5.5.6 of the LNW Timetable Planning Rules					

6 Timetabling Considerations

6.1 Advertised and Working Times

It is not permissible for trains to be specified to be advertised to arrive before or depart after the booked times stated in the working timetable (WTT).

It is permissible for trains to be specified to be advertised to depart before the booked times stated in the working timetable in the following circumstances;

- (i) Where the WTT departure time is delayed to achieve the required headway behind a preceding train or margin following a conflicting move.
- (ii) As an aid to punctual departure where this practice has been agreed between the Train Operator and Network Rail.

By agreement between the Train Operator and Network Rail, trains may be specified to be advertised to arrive after the booked times stated in the WTT. This agreement is used instead of engineering/performance allowances.

6.2 Timing of Light Locomotives

It is a general principle that all light locomotive movements will be timed. Any exceptions to this must be agreed by the appropriate Area Timing Specialist.

7 Appendix A Timing Point Diagrams

The following diagrams are supplementary to the information shown in Section 2.1

LN600 SHAFTHOLME JUNCTION TO RESTON GSP

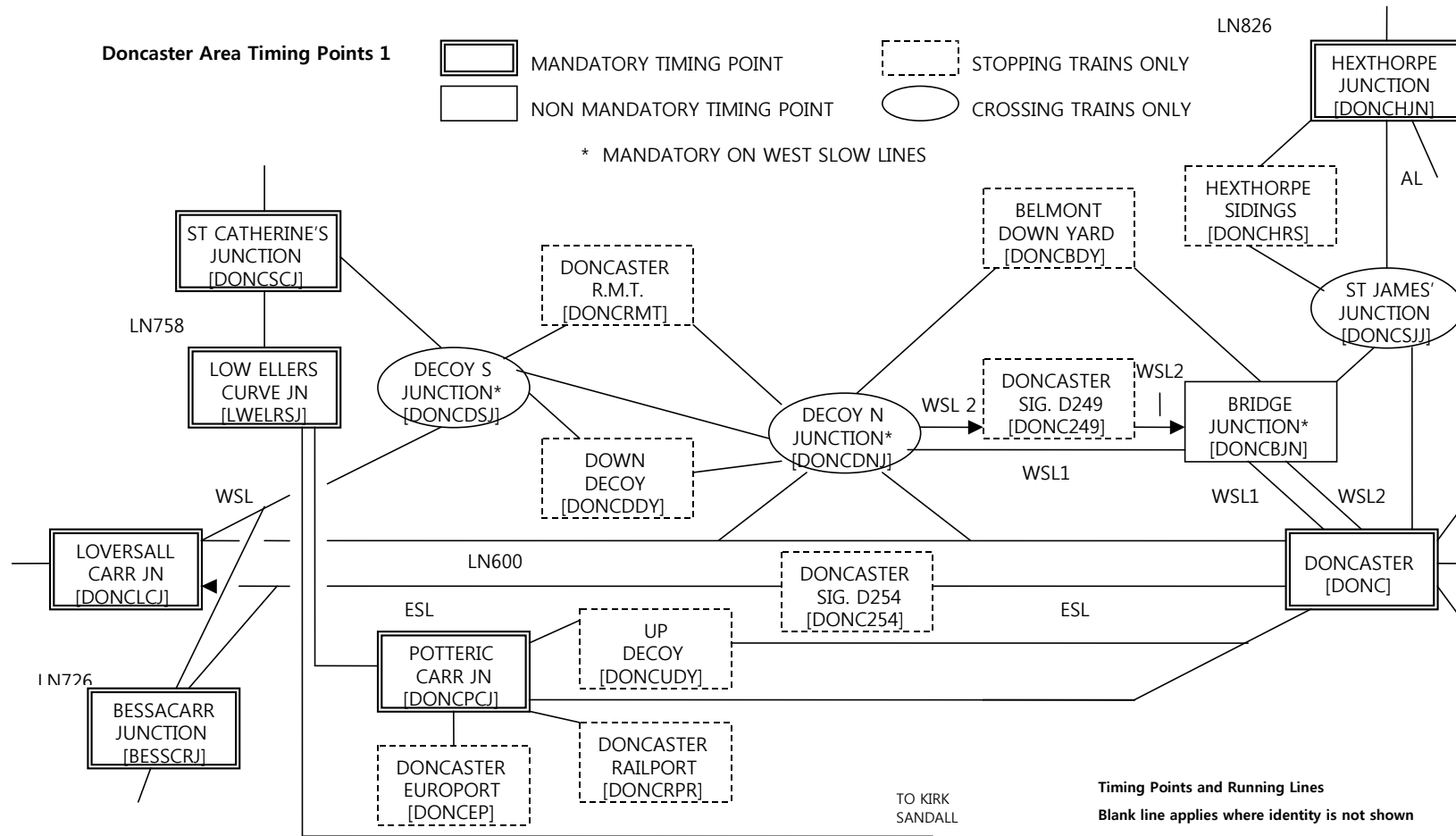

Doncaster Area Timing Points 2

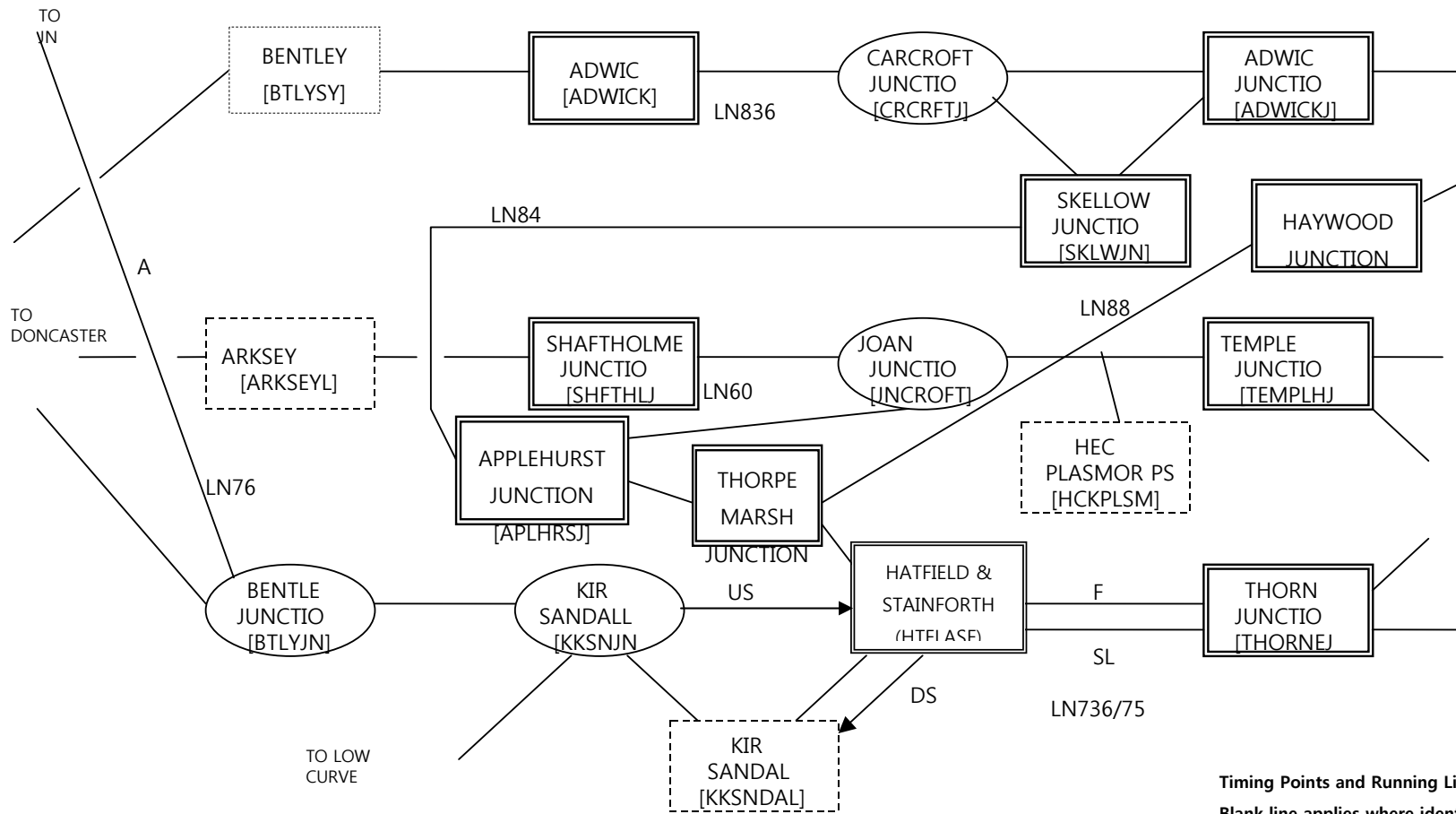
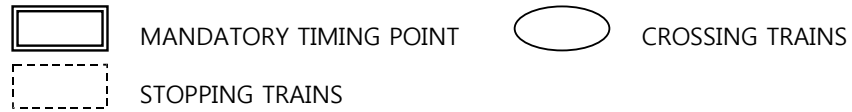

Timing Points and Running Lines
Blank line applies where identity is not shown

Newcastle Area Timing Points 1

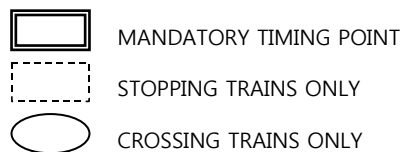

Timing Points and Running
Blank line applies where identity is not

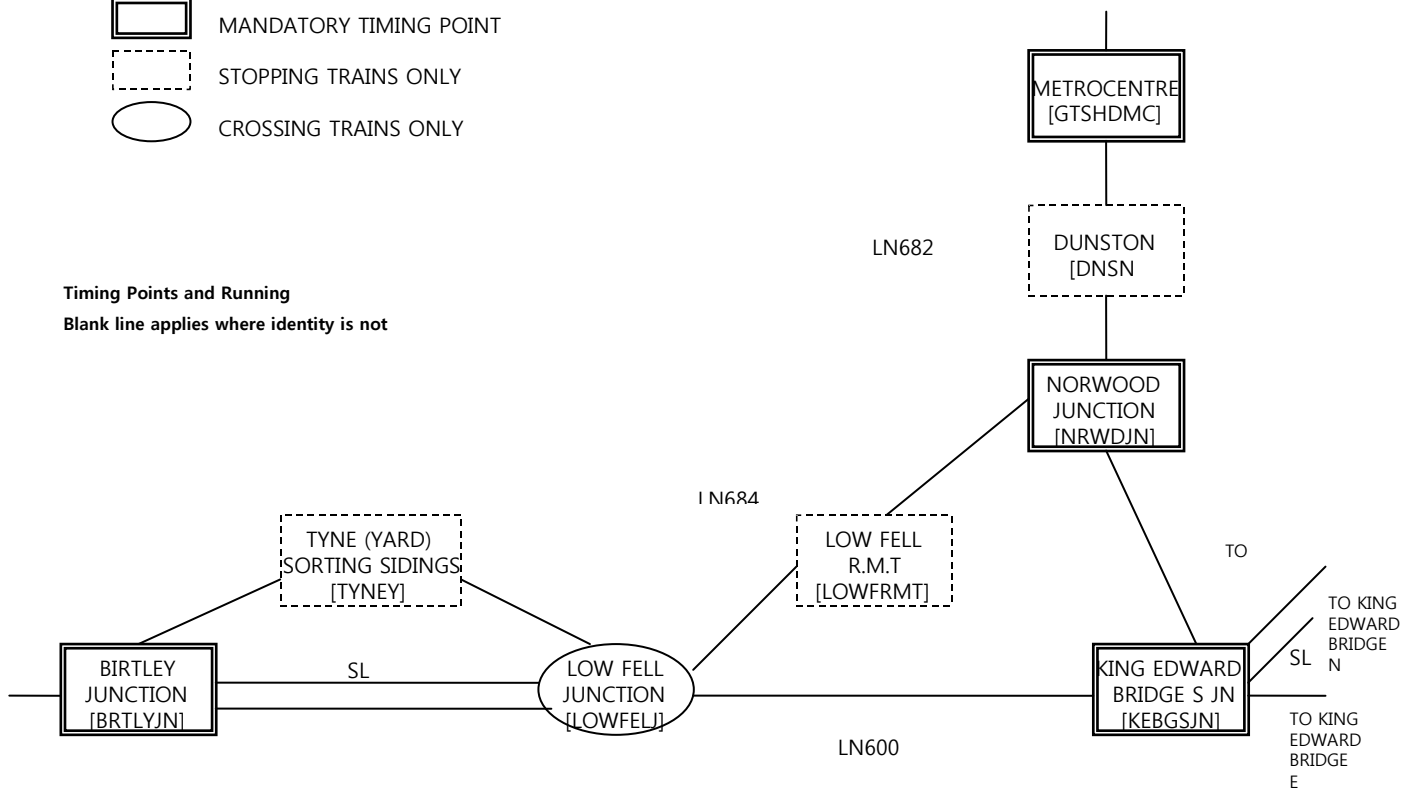

Newcastle Area Timing Points 2



MANDATORY TIMING POINT



CROSSING TRAINS ONLY



STOPPING TRAINS ONLY

Timing Points and Running Lines

Blank line applies where identity is not shown

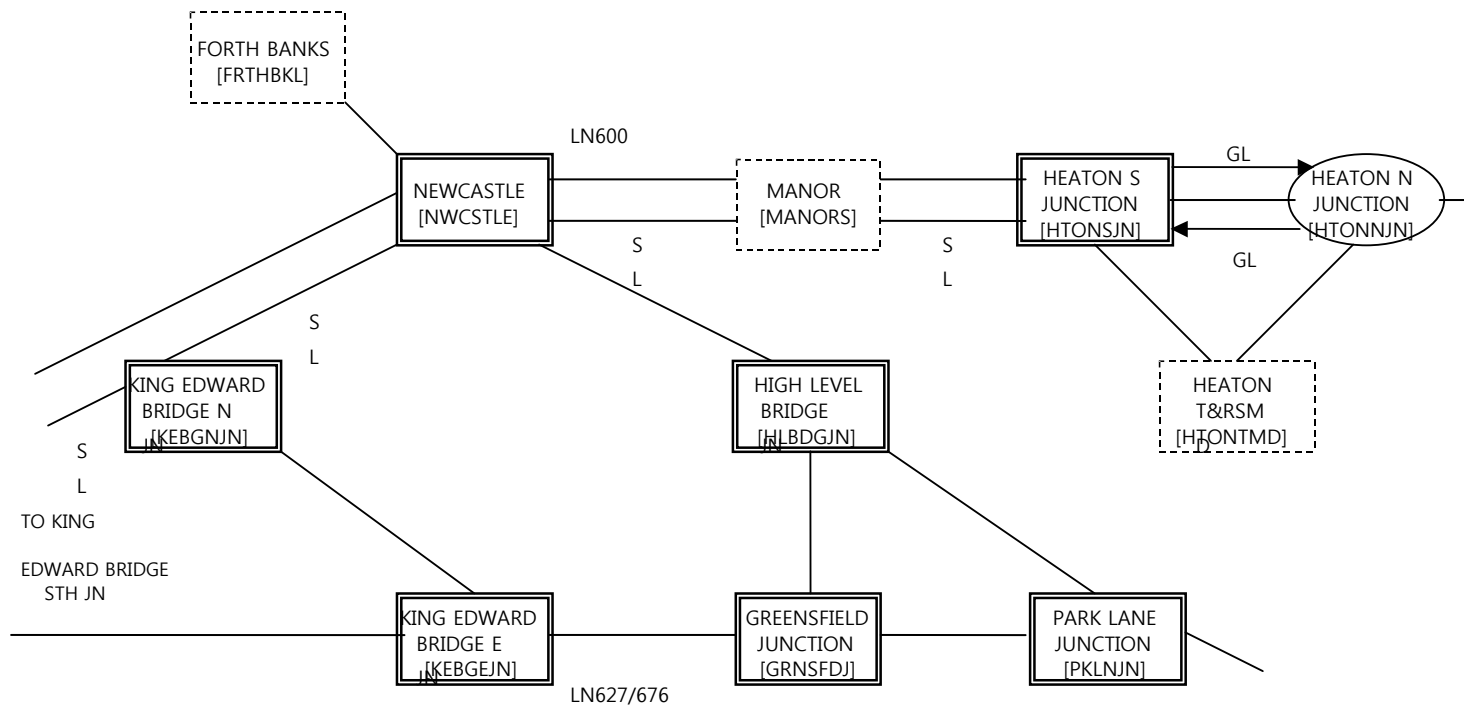

LN836/898/854 HOLBECK JUNCTION TO COLTON JUNCTION

ST CATHERINE'S

Leeds Area Timing Points 1

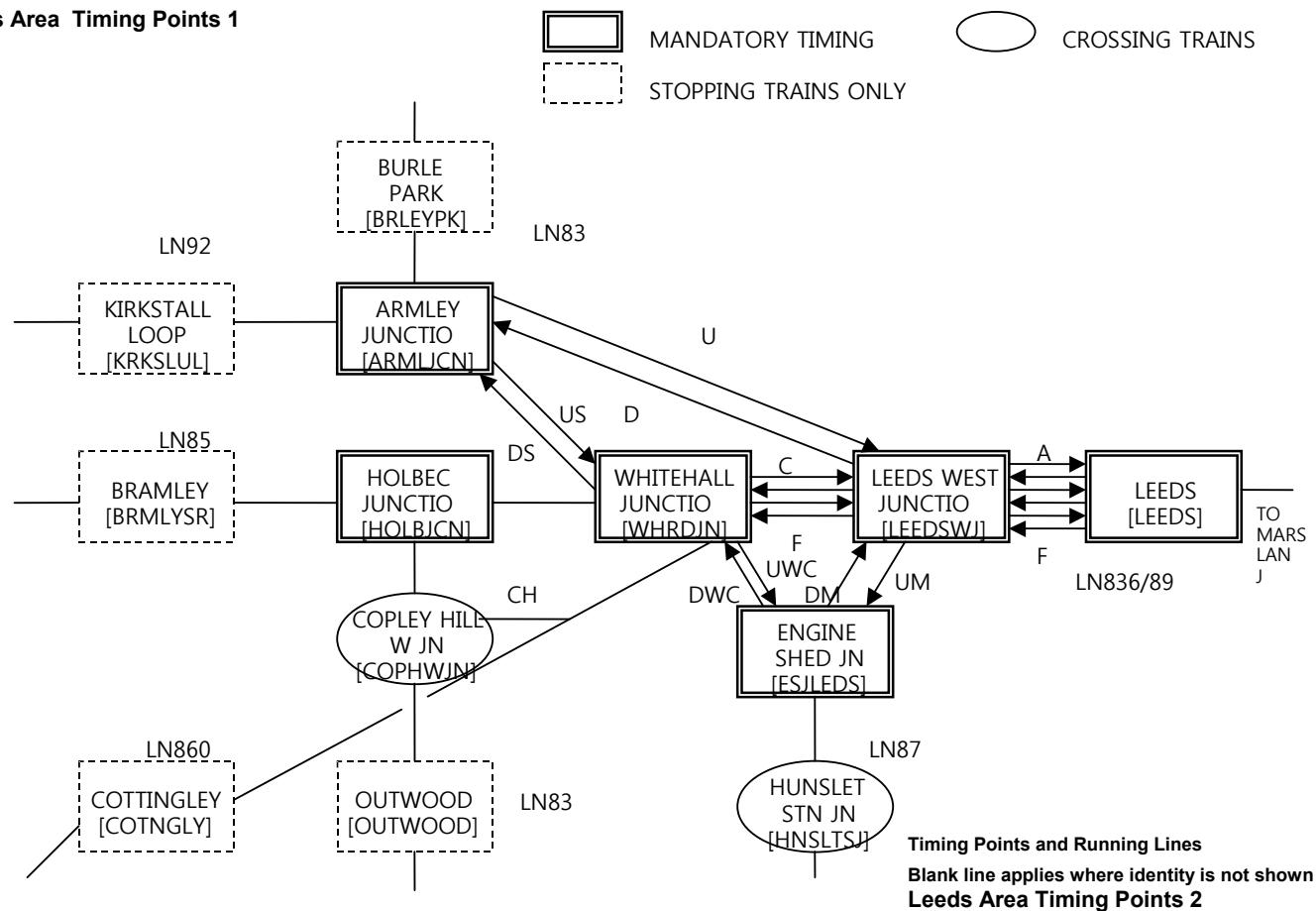

Leeds Area Timing Points

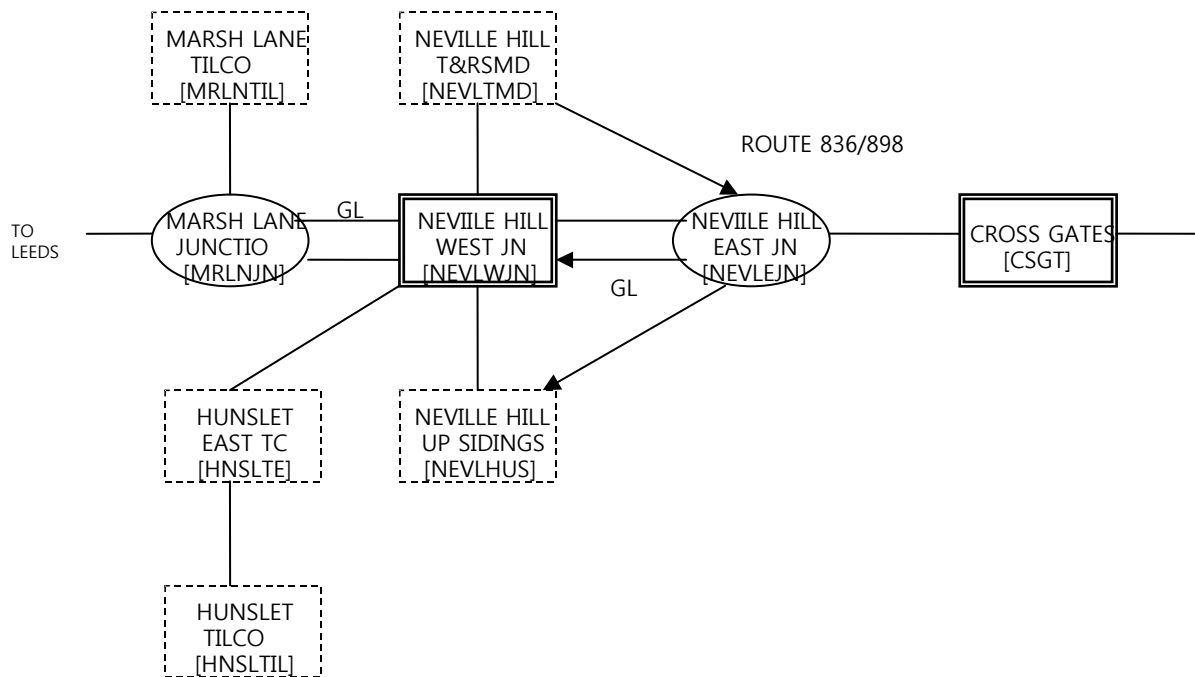
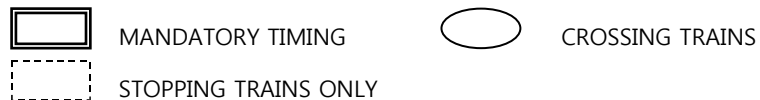

Timing Points and Running
Blank line applies where identity is not