

OPERATOR'S MANUAL

Set-Up Instructions and Parts Catalog for

Model HT-1082

Low Profile Header Transports

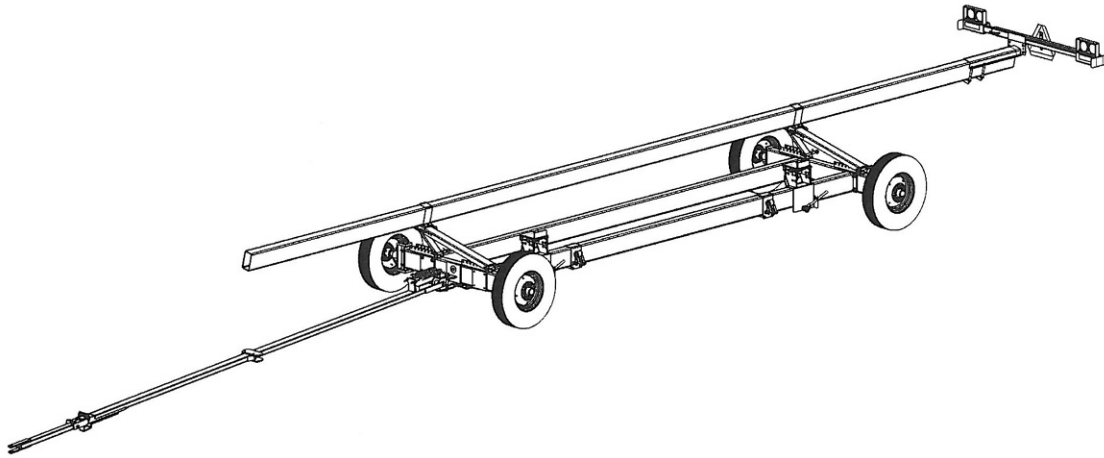

J. & M. Manufacturing Co., Inc.
P.O. Box 547
Fort Recovery, OH 45846

Phone: (419) 375 2376 Fax: (419) 375-2708
E-mail: sales@jm-inc.com Website: www.jm-inc.com

REV-03-30-09

TO THE DEALER:

Read manual instructions and safety rules. Make sure all items on the Dealer's Pre-Delivery and Delivery Check Lists in the Operator's Manual are completed before releasing equipment to the owner.

The dealer must complete the Warranty Registration Card attached to the front inside cover of this manual and return to J. & M. Mfg. Co., Inc. at the address indicated on the card. **Warranty claims will be denied if the Warranty Registration Card has not been completed and returned.**

EXPRESS WARRANTY:

J. & M. Mfg. Co. Inc. warrants against defects in construction or materials for a period of ONE year. We reserve the right to inspect and decide whether material or construction was faulty or whether abuse or accident voids our guarantee.

Warranty service must be performed by a dealer or service center authorized by J. & M. Mfg. Co. Inc. to sell and/or service the type of product involved, which will use only new or remanufactured parts or components furnished by J. & M. Mfg. Co. Inc. Warranty service will be performed without charge to the purchaser for parts or labor based on the Warranty Labor Times schedule. Under no circumstance will allowable labor times extend beyond the maximum hours indicated in the Warranty Labor Times schedule for each warranty procedure. The purchaser will be responsible, however, for any service call and/or transportation of the product to and from the dealer or service center's place of business, for any premium charged for overtime labor requested by the purchaser, and for any service and/or maintenance not directly related to any defect covered under the warranty. Costs associated with equipment rental, product down time, or product disposal are not warrantable and will not be accepted under any circumstance.

Each warranty term begins on the date of product delivery to the purchaser. Under no circumstance will warranty be approved unless (i) the product warranty registration card (attached to the inside of the Operator's Manual) has been properly completed and submitted to the equipment manufacturer. This Warranty is effective only if the warranty registration card is returned within 30 days of purchase.

This warranty does not cover a component which fails, malfunctions or is damaged as a result of (i) improper modification or repair, (ii) accident, abuse or improper use, (iii) improper or insufficient maintenance, or (iv) normal wear or tear. This warranty does not cover products that are previously owned and extends solely to the original purchaser of the product. Should the original purchaser sell or otherwise transfer this product to a third party, this Warranty does not transfer to the third party purchaser in any way. J. & M. Mfg. Co. Inc. makes no warranty, express or implied, with respect to tires or other parts or accessories not manufactured by J. & M. Mfg. Co. Inc. Warranties for these items, if any, are provided separately by their respective manufacturers.

THIS WARRANTY IS EXPRESSLY IN LIEU OF ALL OTHER WARRANTIES OR CONDITIONS, EXPRESS, IMPLIED OR STATUTORY, INCLUDING ANY IMPLIED WARRANTY OF MERCHANTABILITY OR FITNESS FOR PARTICULAR PURPOSE.

In no event shall J. & M. Mfg. Co. Inc. be liable for special, direct, incidental or consequential damages of any kind. The exclusive remedy under this Warranty shall be repair or replacement of the defective component at J. & M. Mfg. Co. Inc.'s option. This is the entire agreement between J. & M. Mfg. Co. Inc. and the Owner about warranty and no J. & M. Mfg. Co. Inc. employee or dealer is authorized to make any additional warranty on behalf of J. & M. Mfg. Co. Inc.

The manufacturer reserves the right to make product design and material changes at any time without notice. They shall not incur any obligation or liability to incorporate such changes and improvements in products previously sold to any customer, nor shall they be obligated or liable for the replacement of previously sold products with products or parts incorporating such changes.

SERVICE:

The equipment you have purchased has been carefully manufactured to provide dependable and satisfactory use. Like all mechanical products, it will require cleaning and upkeep. Lubricate the unit as specified. Observe all safety information in this manual and safety signs on the equipment.

For service, your authorized J. & M. dealer has trained mechanics, genuine J. & M. service parts, and the necessary tools and equipment to handle all your needs.

Use only genuine J. & M. service parts. Substitute parts may void the warranty and may not meet standards required for safe and satisfactory operation. Record the model number and serial number of your equipment in the spaces provided:

Serial # _____ Purchase Date: _____ Purchased From: _____

Please provide this information to your dealer to obtain the correct parts:

MODEL HT-1082 Header Transport Specifications

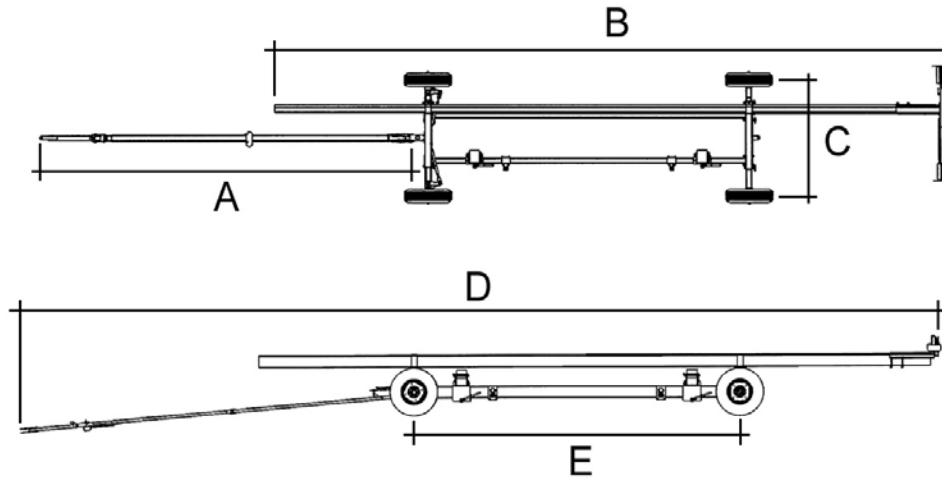

DIMENSIONS	
HT-1082	
A	19'-0"
B	34'-0" – 50'-0"
C	6'-10"
D	48'-0" – 56'-0"
E	18'-6"

SPECIFICATIONS	
Capacity	16,000 lbs. (Gross) 13,500 lbs. (Net)
Weight	2,340 lbs.
Wheel Size	16" x 6"
Tire Size	235/85R16F
Hubs	6 bolt
Spindles	2" diameter
Main Frame	4" x 8" x 3/16" steel tubing
Steel Upper Bar	4" x 8" x 3/16" steel tubing
Adj. Header Mounts	Standard
Tie Down Straps	Standard





GENERAL INFORMATION

TO THE OWNER:

The purpose of this manual is to assist you in operating and maintaining your running gear in a safe manner. Read it carefully. It furnishes information and instructions that will help you achieve years of dependable performance and help maintain safe operating conditions. If this machine is used by an employee or is loaned or rented, make certain that the operator(s), prior to operating:

1. Is instructed in safe and proper use.
2. Reviews and understands the manual(s) pertaining to this machine.

Throughout this manual, the term **IMPORTANT** is used to indicate that failure to observe can cause damage to equipment. The terms **CAUTION**, **WARNING** and **DANGER** are used in conjunction with the Safety-Alert Symbol, (a triangle with an exclamation mark), to indicate the degree of hazard for items of personal safety. When you see this symbol, carefully read the message that follows and be alert to the possibility of personal injury or death.

	This Safety-Alert symbol indicates a hazard and means ATTENTION! BECOME ALERT! YOUR SAFETY IS INVOLVED!
	Indicates an imminently hazardous situation that, if not avoided, will result in death or serious injury.
 WARNING	Indicates a potentially hazardous situation that, if not avoided, could result in death or serious injury, and includes hazards that are exposed when guards are removed.
 CAUTION	Indicates a potentially hazardous situation that, if not avoided, may result in minor or moderate injury.
IMPORTANT	Indicates that failure to observe can cause damage to equipment.
NOTE	Indicates helpful information.

GENERAL INFORMATION (continued)

BOLT TORQUE CHART

Always tighten hardware to these values unless a different torque or tightening procedure is listed for a specific application.

Fasteners must always be replaced with the same grade as specified in the manual parts list.

Always use the proper tool for tightening hardware. SAE for SAE hardware and Metric for metric hardware.

Make sure fastener threads are clean and you start the thread engagement properly. All torque values are given to specification used on hardware defined by SAE J1701 & J1701M (Jul 96).

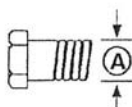

SAE SERIES TORQUE CHART



SAE Bolt Head Identification

SAE Grade 2 (No Dashes)



SAE Grade 5 (3 Radial Dashes)



SAE Grade 8 (6 Radial Dashes)

Diameter (Inches) ^(A)	Wrench Size	MARKING ON HEAD					
		SAE 2		SAE 5		SAE 8	
		Lbs.-Ft.	N-m	Lbs.-Ft.	N-m	Lbs.-Ft.	N-m
1/4	7/16"	6	8	10	13	14	18
5/16	1/2"	12	17	19	26	27	37
3/8	9/16"	23	31	35	47	49	67
7/16	5/8"	36	48	55	75	78	106
1/2	3/4"	55	75	85	115	120	163
9/16	13/16"	78	106	121	164	171	232
5/8	15/16"	110	149	170	230	240	325
3/4	1-1/8"	192	261	297	403	420	569
7/8	1-5/16"	306	416	474	642	669	907
1	1-1/2"	467	634	722	979	1020	1383

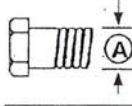

METRIC SERIES TORQUE CHART



Metric Bolt Head Identification

Metric Grade 8.8



Metric Grade 10.9

Diameter & Thread Pitch (Millimeters) ^(A)	Wrench Size	COARSE THREAD				FINE THREAD				Diameter & Thread Pitch (Millimeters) ^(A)
		MARKING ON HEAD								
		Metric 8.8		Metric 10.9		Metric 8.8		Metric 10.9		
		N-m	Lbs.-Ft.	N-m	Lbs.-Ft.	N-m	Lbs.-Ft.	N-m	Lbs.-Ft.	
6 x 1.0	10 mm	8	6	11	8	8	6	11	8	6 x 1.0
8 x 1.25	13 mm	20	15	27	20	21	16	29	22	8 x 1.0
10 x 1.5	16 mm	39	29	54	40	41	30	57	42	10 x 1.25
12 x 1.75	18 mm	68	50	94	70	75	55	103	76	12 x 1.25
14 x 2.0	21 mm	109	80	151	111	118	87	163	120	14 x 1.5
16 x 2.0	24 mm	169	125	234	173	181	133	250	184	16 x 1.5
18 x 2.5	27 mm	234	172	323	239	263	194	363	268	18 x 1.5
20 x 2.5	30 mm	330	244	457	337	367	270	507	374	20 x 1.5
22 x 2.5	34 mm	451	332	623	460	495	365	684	505	22 x 1.5
24 x 3.0	36 mm	571	421	790	583	623	459	861	635	24 x 2.0
30 x 3.0	46 mm	1175	867	1626	1199	1258	928	1740	1283	30 x 2.0

TABLE OF CONTENTS

INTRODUCTION	2
EXPRESS WARRANTY	2
SPECIFICATIONS	3
GENERAL INFORMATION	4
BOLT TORQUE CHART	5
SAFETY RULES	7
SAFETY	7
SAFETY SIGNS	8
SET-UP INSTRUCTIONS	8-12
REPAIR PARTS LIST	
Main Frame and Upper Bar	13
Front Axle Assembly	13
Tie-Down Bracket and Adjustable Header Mount	14
Adjustable Upper Bar Mount	14
Rear Axle Assembly	15
Rear Fender Assembly	15
Light Kit	16
INITIAL OPERATION / MAINTENANCE	17
SERVICE / MAINTENANCE RECORD	18

SAFETY RULES

ATTENTION! BECOME ALERT! YOUR SAFETY IS INVOLVED!

- Safety is a primary concern in the design and manufacture of our products. Unfortunately, our efforts to provide safe equipment can be erased by an operator's single careless act. In addition, hazard control and accident prevention are dependent upon the awareness, concern, judgment, and proper training of personnel involved in the operation, transport, maintenance and storage of equipment.
- Make certain that the operator(s), prior to operating is instructed in safe and proper use and reviews and understands the manual(s) pertaining to this machine.
- Read this manual before you operate this machine. If you do not understand any part of this manual, or need more information, contact the manufacturer or your authorized dealer.

SAFETY

- ✓ Understand that your safety and the safety of other persons are measured by how you service, and operate this machine. Know the positions and functions of all controls before you try to operate them. Make sure to check all controls in a safe area before starting your work.
- ✓ The safety information given in this manual does not replace safety codes, federal, state or local laws. Make certain your machine has the proper equipment as designated by local laws and regulations.
- ✓ A frequent cause of personal injury or death is from persons falling off equipment and being run over. Do not permit persons to ride on this machine.
- ✓ Travel speeds should be such that complete control and machine stability is maintained at all times. Where possible, avoid operating near ditches, embankments and holes. Reduce speed when turning, crossing slopes and rough, slick or muddy surfaces.
- ✓ Collision of high speed road traffic and slow moving machines can cause personal injury or death. On roads, use flasher lights according to local laws. Keep slow-moving-vehicle emblem visible. Pull over to let faster traffic pass.
- ✓ Make sure that the header is fastened securely to the transport before moving.
- ✓ Make sure that everyone is clear of equipment before applying power or moving the machine. NEVER position yourself under or near header when mounting on header transport.
- ✓ Never adjust, service, clean or lubricate the header transport until all power is shut off.
- ✓ Make sure that the implement is fastened securely to the tractor by using the proper hitch pin, clip and safety chains.
- ✓ Before unhooking the implement from the towing unit, be sure to properly block the wheels to prevent the implement from moving.
- ✓ Never overload the header transport. Overloading the header transport is dangerous and can cause extensive damage.
- ✓ Do NOT exceed speeds in excess of 25 MPH. The header transport is designed for heavy loads at slow speeds. Also be sure slow moving vehicle emblem is attached to rear of wagon.
- ✓ IMPORTANT: Use caution when transporting. Be alert of the transport unit's overall width when approaching obstacles, such as post signs and poles, along the road. Check the transport width of the unit to ensure clearance before entering bridges.
- ✓ COMPLY WITH ALL SAFETY WARNINGS AND CAUTIONS IN THIS MANUAL AND IN THE COMBINE OPERATORS MANUAL.
- ✓ WARNING: BE SURE ALL LIGHTS ARE WORKING PROPERLY BEFORE HIGHWAY TRAVEL.

SAFETY SIGNS

ATTENTION: BECOME ALERT! YOUR SAFETY IS INVOLVED!

Replace Immediately If Damaged or Missing!

IMPORTANT: Install new safety signs if the old signs are destroyed, lost, painted over or cannot be read. When parts are replaced that have safety signs, make sure you install a new sign with each new part. New signs are available from the manufacturer or your authorized dealer.

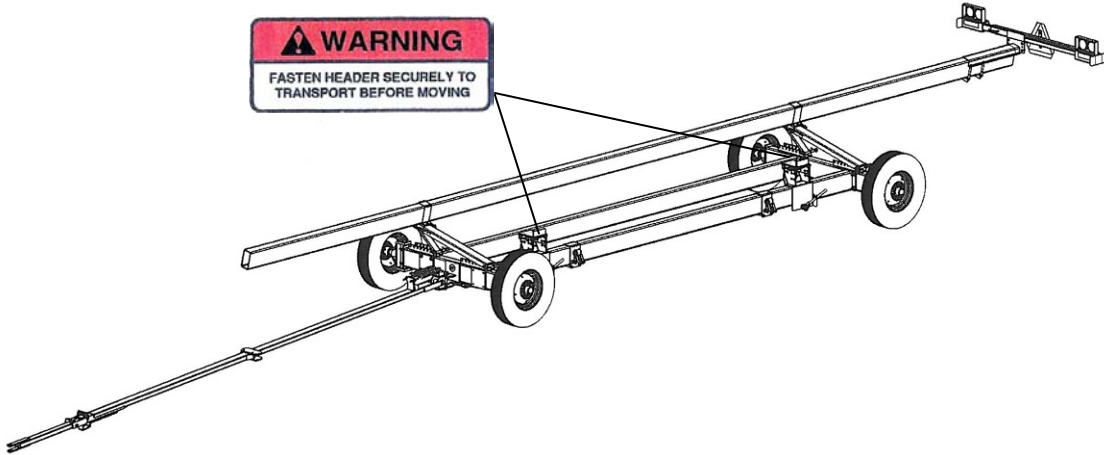

DECAL PARTS LIST

Item #	Part #	Description
1	DW-108	Warning: Fasten Header Securely
2	DC-111	Caution: Check Lug Nuts

SET-UP INSTRUCTIONS

IMPORTANT: Set-up work to be performed by qualified servicemen only.

1. Mounting the Tires

Secure one tire and wheel assembly to each of the hub assemblies on the front and rear axle using the wheel nuts provided. Use a star pattern to tighten the wheel nuts according to SAE standards.

2. Base Main Frame

Secure the Small and Large Lower Bars to the front and rear axle assemblies to complete the base main frame. Position the front and rear axles and lower bars in a rectangular shape with the Large Lower Bar located on the left side of the rectangle and the front axle (with hitch weldment) on the top as shown in the diagram.

Attach each end of the lower bars to the front and rear axles using four 5/8" x 6" Grade 8 bolts, 5/8" flat washers and 5/8" lock nuts.

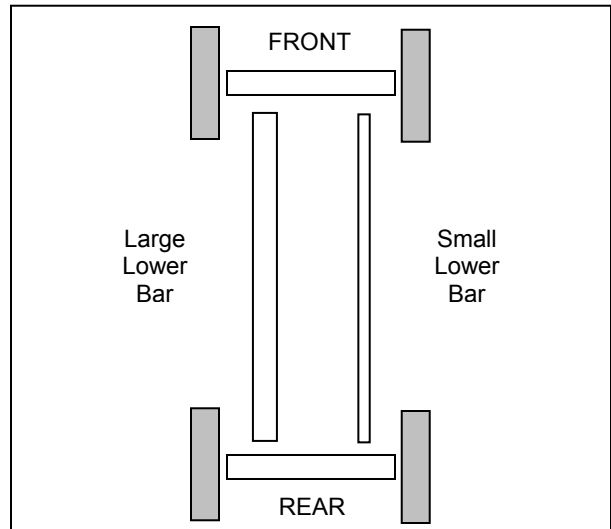

3. Tongue Assembly

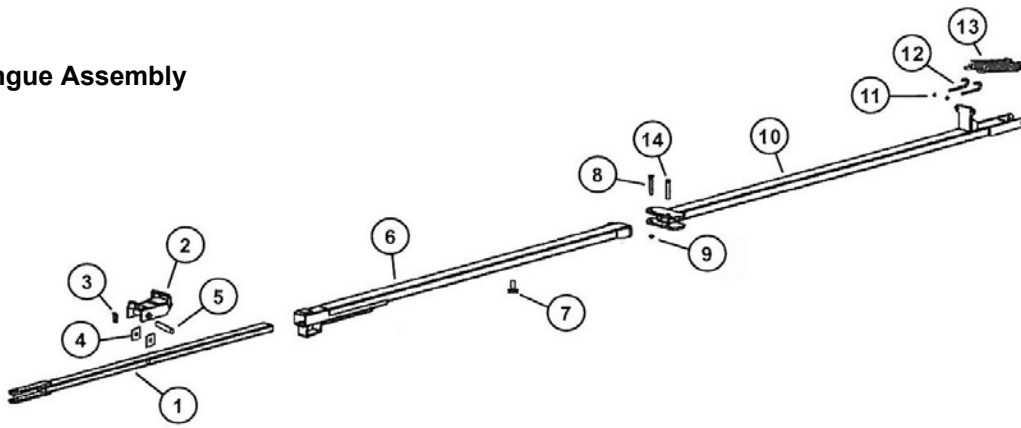

Place the Small Spring (#3) into the holder located at the front of the latch and insert the two spacer blocks (#4) on each side of the inner tongue. Pin the Tongue Latch (#2) to the Inner Tongue (#1) using the 1" dia. x 5 3/4" Pin (#5) and roll pin provided.

Slide the inner tongue into the front half of the Outer Tongue (#6) and insert the 7/8" x 2 1/4" bolt with spacer (#7) into the bottom side of the inner tongue through the opening on the bottom side of the outer tongue. Secure the front half Outer Tongue (#6) to the rear half Outer Tongue (#10) using the 3/4" Pin with Spring Handle (#14) and the 3/4" x 4" Bolt (#8) with 3/4" Nut (#9).

Secure the two 1/2" x 4" J-Bolts and nuts to the rear of the Outer Tongue so the J-Bolts are positioned toward the rear of the tongue. Attach the complete tongue to the hitch weldment on the front axle using the 1 1/4" x 11 3/4" Tongue Bolt and 1 1/4" Hex Nut. Slide the two Large Tongue Springs (#13) around each J-Bolt and connect to the spring holder weldments located on the top of the hitch weldment located on the front axle.

4. Attaching the Adjustable Brackets and Upper Bar.

Upper Bar Channel Support

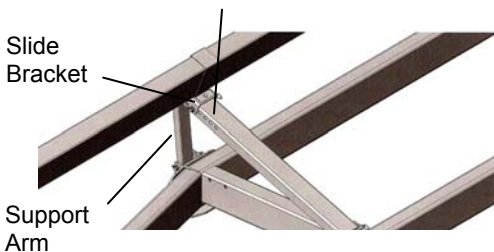

Secure the Upper Bar Channel Support to the left side of the axle channels using one 5/8" x 6" pin and hair pin. Secure the Upper Bar Support Arm to the axle channels located on the right side of the axle using one 5/8" x 6" pin and hair pin. Connect the channel arm to the support arm using one 5/8" x 6" pin and hair pin. The support arms and channel arms can be adjusted and pinned to obtain many different heights and positions.

IMPORTANT: Make sure that all three assemblies are positioned at the same location and height to ensure the upper bar will fit properly.

Secure the Upper Bar Slide Bracket to each the three channel arm using two 5/8" x 6" pins and hair pins. Be sure to position all three slide brackets at the same position on the channel arm. Position the Upper Bar on top of the three slide brackets and secure using the Upper Bar Clamps and two 1/2" washers and two 1/2" lock nuts. The angle of the Upper Bar can be adjusted by removing and repositioning the 5/8" x 6" Hitch Pins in the Upper Bar Adjustable Brackets.

5. Attaching the Adjustable Header Mounts and Tie-Down Brackets

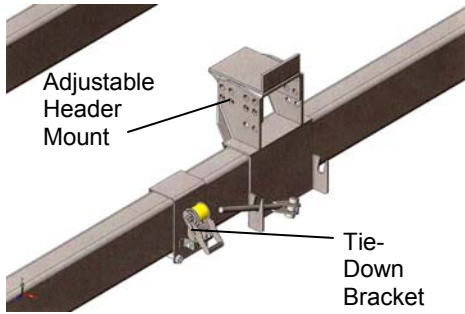

Place the Adjustable Header Mounts and Tie-Down Bracket Assemblies on the large lower bar. Secure the Adjustable Header Mount to the large lower tube using one 3/4" x 6 1/2" Stove Bolt and Clamp Handle Assembly. Secure the Tie-Down Bracket to the large lower tube using two 1/2" x 5 1/2" Bolts and two 1/2" Lock Nuts. Do Not Tighten the 1/2" bolts on the top of the assembly, but allow the Tie-Down Brackets to move freely along the outer tube. The Tie-Down Bracket can be secured with the bolts either above or below the bar as long as the ratchet is positioned with the strap directed upward.

6. Installing the Light Kit

- A. Insert the Main Wiring Harness, end opposite the Flat-Four Connector End, through the grommet located in the outer tongue and exit the rear of the tongue. Continue to main wiring harness through grommet in the middle of the front axle.
- B. Extend the Main Wiring Harness along the rear of the front axle toward the Upper Bar. Insert the harness through the hole located on the bottom side of the Upper Bar and extend the harness out toward the rear of the Upper Bar.
- C. Connect the end of the Main Wiring Harness opposite the Flat-Four Connector to the corresponding end of the Light Enhancer. Store the Light Enhancer inside the Upper Bar.
- D. Place the extension bracket at the rear end of the Upper Bar. Attach using the two angle iron supports and secure with four 1/2" x 7" bolts, washers and nuts.
- E. Place the Light Mounting Bracket at the end of the Extension Bracket Arm so the Light Mounting Bracket is level or horizontal and extends toward the center of the header transport. Secure using two 1/2" x 1 1/4" Grade 5 Flange Bolts and Flange Nuts.
- F. Slide the extendable portion of the Telescoping Arm into the Light Mounting Bracket and tighten the Handle Nut until the bracket is secure. Extend the arm until the light assembly is within 16" of the outer extremity of the unit.
- G. Mount one light assembly at the end of the Light Mounting Bracket (L/H light) and another assembly at the end of the Telescoping Arm (R/H light). Secure each light assembly using four small self-tapping screws. Each light assembly should be mounted so the single amber light is positioned toward the outside of the header, and the amber and red lights are facing rearward. Secure the SMV Emblem to the Light Mounting Bracket using two 1/4" x 1" Bolts and Lock Nuts. Be sure the SMV Emblem remains visible from the rear during highway transport.
- H. Place one amber reflective decal at the outward and front side of both the Telescoping Arm and Light Mounting Bracket as shown. Place one Red and Orange Reflective Decal on the rearward end of the Telescoping Arm and Light Mounting Bracket. The red reflective decal should be placed directly above the orange decal.
- I. Connect each light to the corresponding wires on the Light Enhancer using the Light Wiring Harness. Using the enclosed self tapping screws, secure the Wire Cover over the Light Wire Harness along the upper bar.

PARTS LIST

Main Frame and Upper Bar

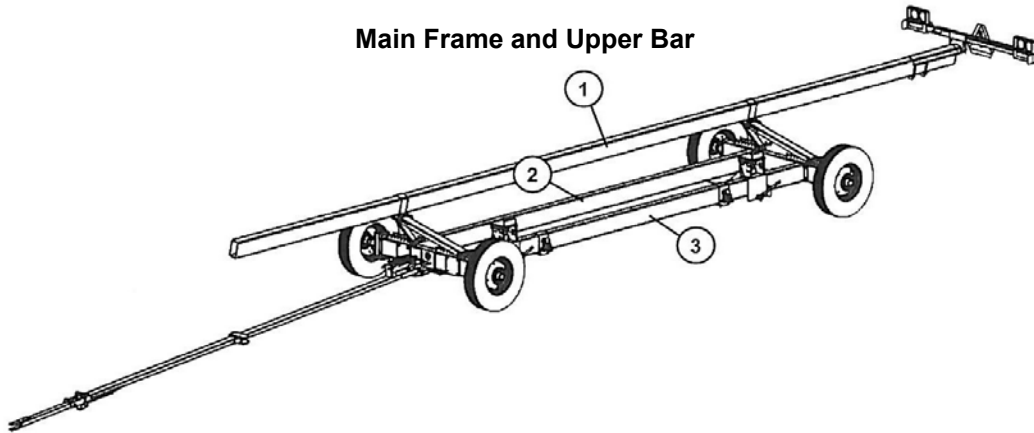

#	Part #	Description
1	UB-24H	48' L Upper Bar (two 24' L bars with splice plate)
1	SP-24H	Splice Plate for 24' Upper Bar
1	UB-42H	42' L Upper Bar
1	UB-38H	38' L Upper Bar
1	UB-32H	32' L Upper Bar
2	SLB-1082	4" x 6" Small Lower Bar (HT-1082)
3	LLB-1082	4" x 8" Large Lower Bar (HT-1082)

#	Part #	Description
4	586G8B	5/8" x 6" Grade 8 Bolt
5	58-FW	5/8" Flat Washer
6	58LN	5/8" Lock Nut
7	12312B	1/2" x 3 1/2" Bolt for Splice Plate
8	12-W	1/2" Regular Washer
9	12-LN	1/2" Lock Nut

Tongue Assembly

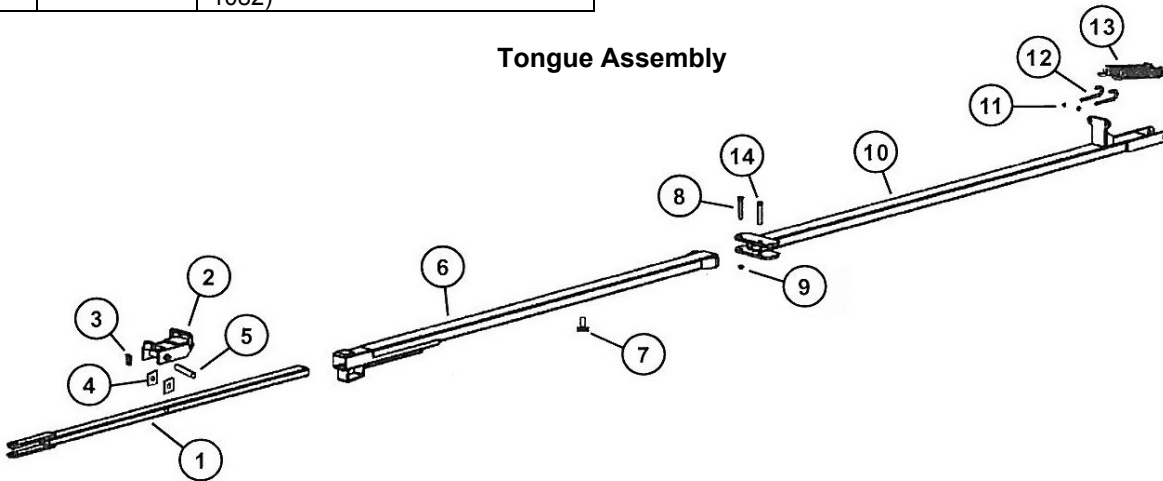

#	Part #	Description
1	IT-HT10	Inner Tongue (42" L)
1	IT-HT10L	Inner Tongue (65" L)
2	TL-615NS	Tongue Latch
3	SS-615NS	Small Spring in Latch
4	SB-212	Spacer Blocks
5	LS-610	Latch Pivot Shaft, 1" dia. x 5 3/4"
6	OT-HT10-F	Outer Tongue (front)
7	78214-BS	7/8" x 2 1/4" Bolt with Spacer

#	Part #	Description
8	344B	3/4" x 4 Bolt
9	34N	3/4" Nut
10	OT-HT10-R	Outer Tongue (rear)
11	12-N	1/2" Regular Nut
12	124-JB	1/2" x 4" J-Bolt
13	TS-615H	Large Tongue Spring
14	34PSH	3/4" Pin with Spring Handle

PARTS LIST

Front and Rear Axle Assembly

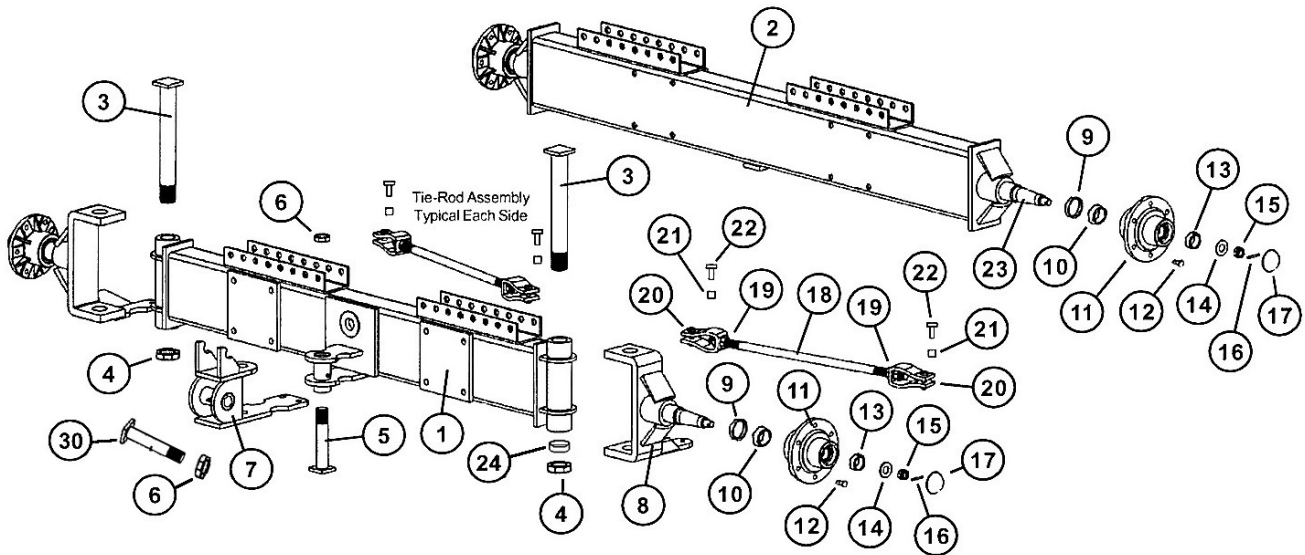

#	Part #	Description
1	FA-1082	Front Axle Only, Less Hub and Spindle Assembly and Hitch
2	RA-1082	Rear Axle Only, Less Hub Assy
3	SPB-134	Spindle Bolt, 1 3/4" x 13 1/2"L
4	HN-134	1 3/4" Hex Nut
5	KP-1082	1 1/4" King Pin Vertical Hitch Bolt
6	HN-114	1 1/4" Hex Nut
7	HW-1082	Hitch Weldment
8	SA-1082L	2" Spindle and "U" Assy (left)
8	SA-1082R	2" Spindle and "U" Assy (right)
9	106166	Grease Seal
10	105771	Cone, Large 105771 or LM501349
11	106164	Hub, with cups and bolts, 6 bolt
12	105144	Wheel Bolt (105144)
13	104082	Cone, Small 104082 or LM67048
14	104581	Spindle Washer
15	103289	Slotted Spindle Nut
16	CP-316	Cotter Pin

#	Part #	Description
17	103969	Dust Cap
18	TR-1082	Tie Rod
19	HN-78L	7/8"-14 N/F Nut (L/H)
19	HN-78R	7/8"-14 N/F Nut (R/H)
20	TRE-78L	Tie Rod End (L/H)
20	TRE-78R	Tie Rod End (R/H)
21	BB-58	5/8" Bronze Bushing
22	SB-58	5/8" Step Bolt
23	RS-1082	Rear Spindle Only
24	EB-134	1 3/4" Bronze Bushing
25	1633	Grease Fitting (not shown)
26	105770	Cup, Large 105770 or LM501310 (not shown)
27	104081	Cup, Small 104081 or LM67010 (not shown)
28	WR-166	Wheel Rim, 16x6" (not shown)
29	16NT	16" New Tire (not shown)
30	TB-1082	Tongue Bolt (1 1/4" x 6 3/8")

PARTS LIST

Tie-Down Bracket and Adjustable Header Mount

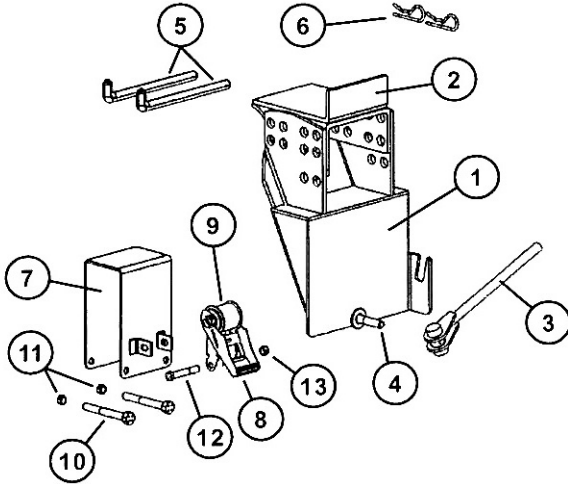

#	Part #	Description
1	AB-L2	Lower Adjustable Bracket
2	AB-U2L	Upper Adjustable, Bracket (L/H)
2	AB-U2R	Upper Adjustable, Bracket (R/H)
2	AB-U2L-MD	Upper Adj. Bracket (L/H) (MacDon)
2	AB-U2R-MD	Upper Adj. Bracket (R/H) (MacDon)
3	CHA2	Clamp Handle Assembly
4	CB58612	Carriage Bolt, 5/8" x 6 1/2"
5	3412P	3/4" x 12" Pin
6	HC-CP	Cotter Pin
7	TDMB-2	Tie Down Mounting Bracket
8	RA-1	Ratchet
9	TDS-1	Tie-Down Strap and Hook Assy.
9	TDS-1L	Tie-Down Strap and Hook Assy w/ D-Ring Strap (for MacDon heads)
10	12512G5B	1/2" x 5 1/2" Grade 5 Bolt
11	12LN	1/2" Lock Nut
12	12234G5B	1/2" x 2 3/4" Grade 5 Bolt
13	12NLN	1/2" Nylon Lock Nut

Adjustable Upper Bar Mount

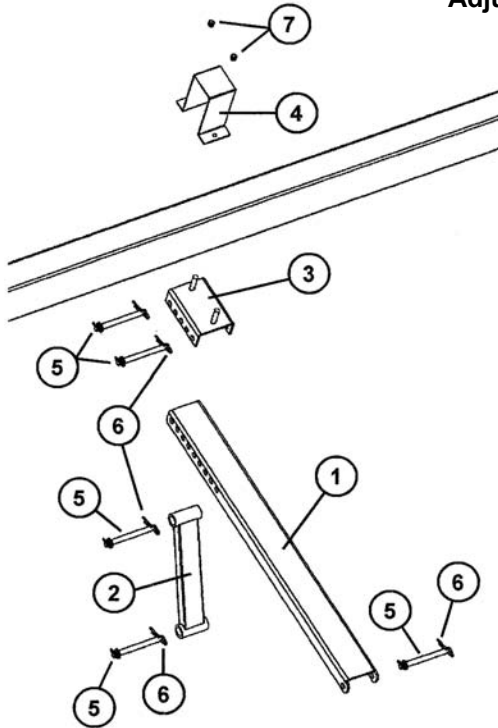

#	Part #	Description
1	UBCM-3	Upper Bar Channel Mount
2	UBSA-3	Upper Bar Support Arm
3	UBSM-3	Upper Bar Slide Mount
4	UBC-3	Upper Bar Clamp
5	HP-586	5/8" x 6" Pin
6	316HP	3/16" Hair Pin
7	121-B	1/2" x 1" Bolt
8	12LN	1/2" Lock Nut

PARTS LIST

Light Kit

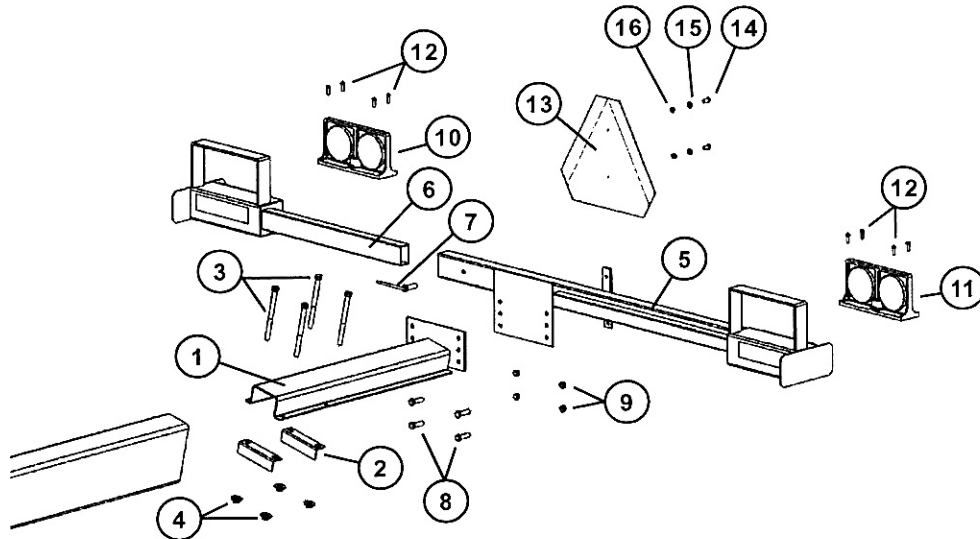

#	Part #	Description
1	EB-1	Extension Bracket
2	AIS-2	Angle Iron Support
3	127-HB	1/2" x 7" Hex Bolt
4	12-N	1/2" Nut
5	LMB-1	Light Mounting Bracket
6	TA-1	Telescoping Arm
7	HDN-12	1/2" Handle Nut
8	12114-G5-FB	1/2" x 1 1/4" Grade 5 Flange Bolt
9	12-FN	1/2" Flange Nut
10	RLT-R	Light Assembly (R/H)
11	RLT-L	Light Assembly (L/H)
12	38STS	Self Tapping Screw (large)
13	SMV-1	SMV Emblem

#	Part #	Description
14	141-CB	1/4" x 1" Bolt
15	14-W	1/4" Washer
16	14LN	1/4" Lock Nut
17	RD-A1	Amber Reflective Decal
18	RD-R1	Red Reflective Decal
19	RD-O1	Orange Reflective Decal
20	LWH-1	Light Wiring Harness (rear only)
21	LE-1B	Light Enhancer
22	WH-1NC	Main Wiring Harness (front only)
23	GR-134	Rubber Grommet
24	WC-1	Wire Clip
25	12-WR	1/2" Regular Washer

INITIAL OPERATION / MAINTENANCE

BE CERTAIN THAT ALL POWER IS SHUT OFF BEFORE SERVICING THE HEADER TRANSPORT

Before the header transport is put into service:

- ✓ Has the Slow-Moving Vehicle Emblem been properly positioned at the rear of the header transport?
- ✓ Have all danger, warning, caution and important signs on the equipment been read and understood? If employees or others use or are near this equipment, make sure that they also have read and understood all danger, warning, caution and important signs on the equipment and have also read the operator's manual.
- ✓ Are all braces, bolts, nuts, lug bolts and lug nuts properly fastened?
- ✓ Has the header transport been properly fastened to the towing unit? Use a good quality hitch pin with clip and safety chains.
- ✓ Are the rear amber extremity lights properly positioned? Extend lights within 16" of the left and right extremities of the header.

SAFETY CHAIN USER INSTRUCTIONS

- a) Secure the safety chain by looping it around the tongue support located on the underside of the Outer Tongue. Run the chain through the intermediate support located on the underside of the inner tongue and connect to the towing machine's attaching bar.
- b) Do Not allow more slack than necessary for articulation.
- c) Do Not use any intermediate support as the attaching point.
- d) Store the safety chain by securing it around the tongue.
- e) Replace the safety chain if one or more links or end fittings are broken, stretched or otherwise damaged or deformed.



OPERATING INSTRUCTIONS/MAINTENANCE

- Adjust the brackets on the header transport to best fit your make and model header. When mounting the header, NEVER position yourself under or near the header. Securely fasten the header to the header transport.
- Do not exceed the load and size limits of the unit.
- Keep the tires properly inflated. Both under inflation and over inflation can greatly reduce tire life.
- Inspect bracing and welds periodically and repair immediately if needed. Failure to repair could cause extensive damage and greatly reduce the life of the unit.
- Repack the bearings in the hub assembly once a year or as needed. Use a good quality bearing lubricant such as Bearing Gard MK1 or equivalent.
- Grease the ball using the zerk on the front gooseneck assembly every 8 hours or as needed.
- Be sure to check the hub nuts often and keep them properly tightened.

BRAKING SYSTEM REQUIREMENTS:

Tow Loads Safely

Stopping distance increases with speed and weight of towed loads, and on slopes. Towed loads with or without brakes that are too heavy for the tractor or are towed too fast can cause loss of control. Consider the total weight of the equipment and its load.

Observe these recommended maximum road speeds, or local speed limits which may be lower:

- If towed equipment does not have brakes, do not travel more than 32 km/h (20 mph) and do not tow loads more than 1.5 times the tractor weight.
- If towed equipment does have brakes, do not travel more than 40 km/h (25 mph) and do not tow loads more than 4.5 times the tractor weight.

Ensure the load does not exceed the recommended weight ratio. Use additional caution when towing loads under adverse surface conditions, when turning, and on inclines.

SERVICE / MAINTENANCE RECORD

Date	Description	Notes