

# LPB<sup>®</sup>

## 2-20 SYSTEM *for Carrier Current Broadcasting*

**Burden Associates**  
20944 Sherman Way, Suite 216  
Canoga Park, Calif. 91303  
(213) 340-4590

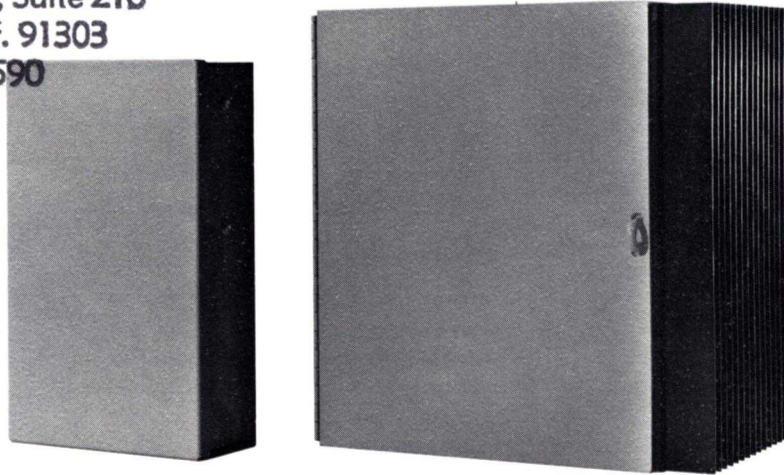

- Variable Output Power
- All Solid State
- Ultra Stable Digital Oscillator Circuitry
- Elliptic Function Output Filter
- RF Output and Modulation Metering
- Audio Performance Exceeds Licensed Broadcast Requirements

The LPB 2-20 Carrier Current System is the result of over 10 years of research on devices and circuits for carrier current requirements from the company with 18 years of nationally known carrier current experience and over 14,000 units in the field. It utilizes the latest technology, resulting in a transmitter whose specifications exceed most of those required of commercial AM broadcasters operating under Part 73 of the F.C.C. Rules.

Designed expressly for carrier current installations, the 2-20 System is comprised of a TX2-20 AM Transmitter and a T-8 Power Line Interface which includes an SWR meter, dummy load, capacitance decade and power system coupling components for an optimum match to a building power system.

### TRANSMITTER

The TX2-20 Transmitter is completely solid state using a balanced emitter output transistor pair which will withstand power line mismatch and output short circuit conditions. A high stability crystal oscillator operates at six times the output frequency and utilizes digital countdown circuitry. An elliptic function output filter provides the highest degree of RF harmonic suppression.

A switch selectable internal meter reads percentage modulation and relative RF power output.

All controls (power switch, audio gain and output power adjust) are located inside the transmitter's lockable and tamper-proof wall mount case.

The TX2-20 Transmitter as used in the 2-20 System for carrier current broadcasting can provide reception of broadcast quality.

### POWER LINE INTERFACE

The T-8 Power Line Interface required as part of the 2-20 System is designed to provide optimum coupling into single or 3-phase power systems. By combining the functions of power line inductance correction, power line isolation, dummy load and VSWR metering, the 2-20 System requires no further test equipment for installation, monitoring or maintenance.

A dual sensitivity SWR bridge, output impedance selector and power line inductance cancellation capacitance decade assure an optimum match. The toroidal ferrite core transformer provides an extremely effective means of isolating (over 70dB) the transmitter from the 60 Hz AC power system, thus preventing 60Hz transmitter hum and component damage as a result of power line energy transfer back into the transmitter circuitry.

# 2-20 SYSTEM

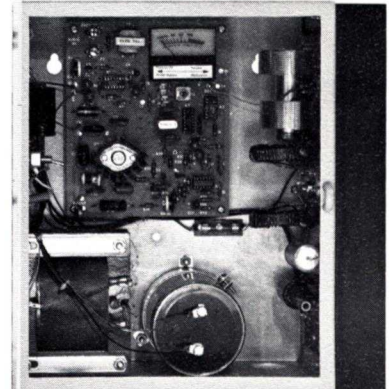
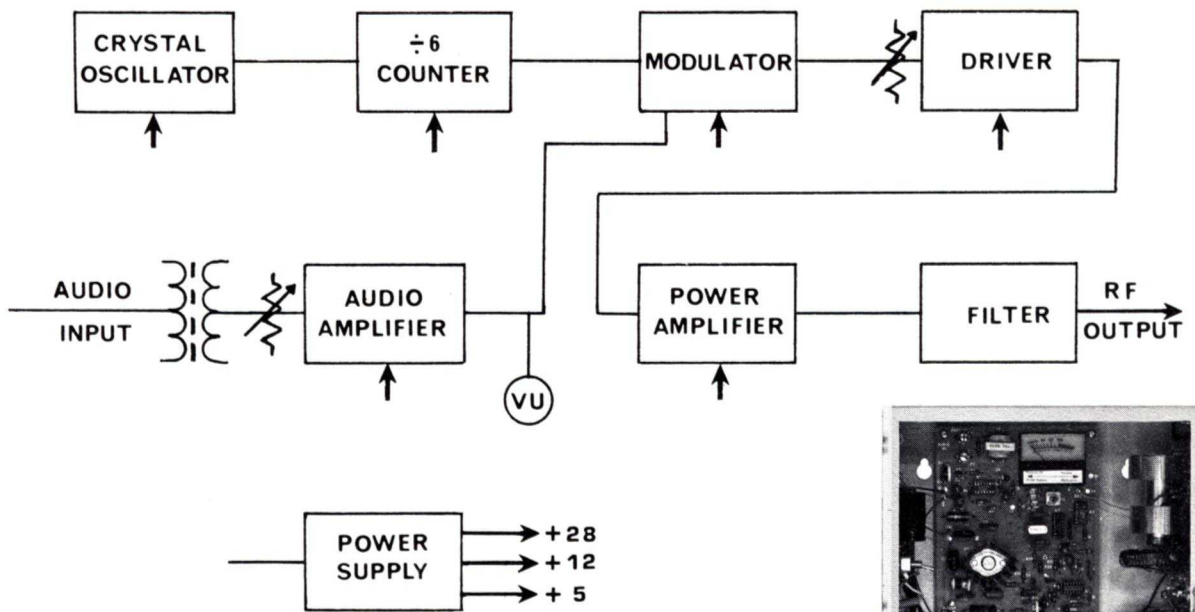

**BLOCK DIAGRAM, TX 2-20 TRANSMITTER**

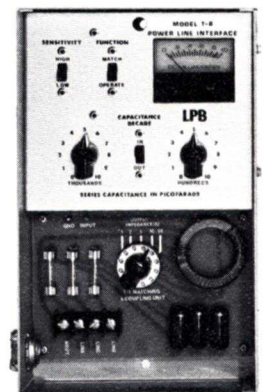
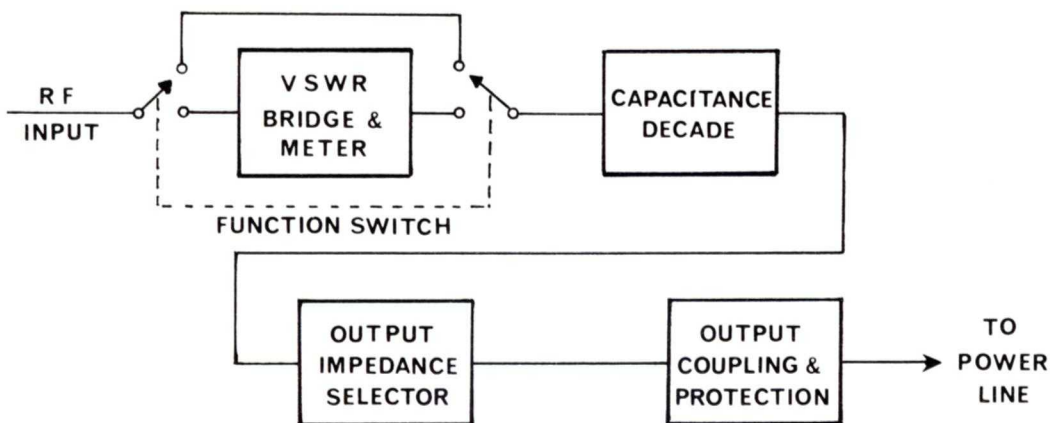

**BLOCK DIAGRAM, T-8 POWER LINE INTERFACE**

# ACCESSORIES

## T-8 POWER LINE INTERFACE



The LPB Model T-8 Power Line Interface, which is a part of the 2-20 Carrier Current System, is available separately when required for use with LPB T1A Power Splitters. The Model T-8 may also be utilized for power line coupling and test purposes with previous types of LPB Carrier Current transmitters and Linear Amplifiers.

## T1A POWER SPLITTER

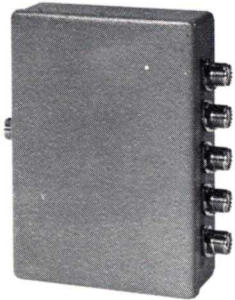

The LPB T1A Power Splitter accepts an RF signal output from a carrier current transmitter and divides the output power into equal portions. This may be required to drive two or more power distribution systems in adjacent locations.

Standard models of the T1A are available to divide the input power into 2, 3, 4, 5 or 6 equal portions. These individual outputs are then each coupled into the power system with a T-8 Power Line Interface.

## LA2-20 LINEAR RF AMPLIFIER

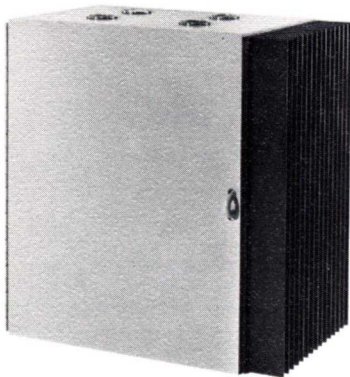

The LPB Model LA2-20 Linear RF Amplifier is used as a 20 watt signal repeater to boost the RF output signal from a carrier current distribution system into the power system of a very large building or complex of buildings. Useful when a 2-20 System is split into four or more power system coupling points or when expansion is required, any number of linear RF amplifiers can be connected to the transmitter output.

Installation of the LA2-20 Linear RF Amplifier is extremely simple. The coaxial cable from the carrier current transmitter is routed to each linear RF amplifier in the system and then, at last, to a dummy load to insure proper coupling of the entire string. A model T-8 power line interface unit must be used with each linear RF amplifier to couple the signal into the building power wiring system.

With a transmitter/linear RF Amplifier System, the interconnecting coaxial cable routing is "series string" from unit to unit. In certain installations, because of cable routing restrictions, this may be of advantage over the use of a single transmitter with divided output. Each Model LA2-20 Linear Amplifier system includes a Model T-8 Power Line Interface.

- .001% CARRIER FREQUENCY STABILITY OPTION
- 230 VOLT OPERATION OPTION
- RF PATCH CORD ASSEMBLY
- NEMS CLARKE BROADCAST FIELD STRENGTH METER
- LPB MODEL S-1A AUDIO DISTRIBUTION AMPLIFIER
- LPB MODEL S-2 AM COMPRESSOR/LIMITER

# SPECIFICATIONS

## TX2-20 TRANSMITTER

R. F. Power Output	Adjustable, 2-20 watts	Audio Frequency Response	20 Hz to 15 kHz $\pm$ 1.5 dB
Type of Emission	(A3) Amplitude modulation	Audio Frequency Distortion	Less than 1.5% at 85% modulation
Frequency Range	530 kHz to 1610 kHz		Less than 3% at 99% modulation
R. F. Output Impedance	50 ohms, unbalanced	Metering	% modulation and relative RF power output
Carrier Frequency Stability	$\pm$ 0.003%, 0 to 100°F	Connectors	RF output: SO-239 coaxial connector
R. F. Harmonic Suppression	Better than 40 dB below carrier		Audio Input: Screw Terminals
Carrier Shift (0-100% modulation)	Less than 2%	Line Cord	3 conductor, moulded plug with ground, 5 feet long
Noise Level	At least 55 dB below 100% modulation	Power	117 VAC 50/60 Hz, 120 watts
Audio Input Level (for 100% modulation)	-15 dBm to +15 dBm	Size	Width 11.75", Height 12", Depth 6.5"
Audio Input Impedance	600 ohm, transformer balanced	Weight	19 lbs.

## T-8 POWER LINE INTERFACE

Power Input	25 watts RMS, continuous (operate mode)	Input Connection	SO-239 Coaxial connector
Input Impedance	50 ohms, unbalanced	Output Connections	Screw terminal barrier strip
Output Impedance	Switch selectable: 1, 2, 5, 10 or 50 ohms	Output Coupling Capacitors	0.1 mfd, 600 working volts, mylar. (500 V.A.C. max. line to line)
Frequency Range	530 kHz to 1610 kHz	Metering	SWR bridge
Power Line Inductance Correction	100 pf to 11,000 pf capacitor decade	Dummy Load (match position)	50 ohms
Output Transformer	Toroidal with special ferrite core	Size	Width 6.5", Height 10.5", Depth 2.75"
		Weight	2.5 lbs.

## T1A POWER SPLITTER

Input Impedance	50 ohms, balanced	Insertion Loss	.3 dB per output
Output Impedance	50 ohms, unbalanced (other available on special order)	Input/Output Connections	Standard SO-239 coaxial connectors
Power Input	Up to 50 watts RMS, continuous	Dimensions	Width 6.25", Height 7.25", Depth 2"
Frequency Range	530 kHz to 1610 kHz	Weight	Approximately 14 oz.
Outputs	2, 3, 4, 5 or 6 (specify when ordering)		

*Special division ratios and impedance levels available to order.*

## LA2-20 LINEAR AMPLIFIER

R. F. Power Output	Adjustable 0-20 watts	Connectors	3 type SO-239 coaxial connectors
Frequency Range	530 kHz to 1610 kHz	Power Requirements	117 VAC, 50/60 Hz, 100 watts maximum
Distortion	Intermod 30 dB down or better at 20 watts output	Dimensions	Width 11.75", Height 12", Depth 6.5"
R. F. Input Impedance	10,000 ohms resistive	Weight	18 lbs.
Input Level	5 volts carrier minimum		

# LPB

LPB Inc.

520 Lincoln Highway, Frazer, Pa. 19355 (215) 644-1123

# **Limited Area AM Broadcasting**

Limited area (or carrier current) broadcasting is an old and forgotten technique which predates the method of broadcasting you now hear every day. The basic difference between the two is the method which the signal is brought to the listener. In carrier current, the transmitter output is coupled directly into the AC power distribution system of a building or group of buildings; conventional broadcasting puts the transmitter output into an antenna to cover a wide area. It is obvious then that carrier current serves a limited geographic area containing a special interest audience, while conventional broadcasting covers the largest possible area.

Since the signal is fed directly into the AC lines, they become transmission lines carrying the radio signal and the electric power as well. The result is an "antenna" network which radiates an RF signal into a relatively small area throughout and around the building (s). A radio in the building will receive the signal through the power cord and through the built-in antenna, and a battery operated radio will receive the signal via its built-in antenna when the radio is in proximity to the building. Other sources of "antenna" are also available for carrier current broadcasting, such as exit sign wiring throughout the building and stringing your own antenna throughout the inside of the building. However, these techniques aren't as effective because they don't "blanket" the building with a network of wiring as does the power system, hence signal strength and quality may vary.

Limited area broadcasting is subject to Part 15 of the Rules and Regulations of the Federal Communications Commission. There are two cardinal rules which must be met:

1. You cannot interfere with a licensed operation.
2. Signal strength must be controlled.

Neither rule presents any hardship if the system is properly designed. It is easy to avoid another broadcaster's frequency by checking before selecting a frequency, and signal strength, which is measured by checking the amount of radiation from your building, and can be readily controlled. The distance your signal may be heard under F.C.C. Rules is approximately 250 feet, depending upon the frequency used.

Limited area broadcasting provides the listener reception quality the equal of conventional AM radio broadcasting, yet without any licensing requirement and at unparalleled initial and operating economy.

*Want to delve further? We will be pleased to send you our brochure  
LIMITED AREA BROADCASTING.*



LPB Inc.  
520 Lincoln Highway  
Frazer, Pa. 19355  
(215) 644-1123

Over 8,000 units of LPB equipment

serve these 500 College Broadcasters . . .

Abilene Christian College  
Adams State College  
Adelphi University  
University of Akron  
University of Alaska  
University of Alberta  
Alderson-Broaddus College  
Alfred University  
Algonquin College  
Allegheny College  
Alliance College  
American International Col.  
American University  
Andrews University  
Antelope Valley College  
Antioch College  
Ashland College  
Atlanta University  
Augustana College  
Babson Institute  
Ball State University  
Becker Junior College  
Belmont Abbey College  
Beloit College  
Bemidji State College  
Bergen Community College  
Bethany Bible College  
Bethel College  
Bethune-Cookman College  
Bloomfield College  
Blue Mountain Community Col.  
Bluffton College  
Boston University  
Bowling Green University  
Brandeis University  
Brandywine College  
University of Bridgeport  
Bristol Community College  
Univ. of British Columbia  
Brown University  
Brown University  
Bucknell University  
Bucks County Community Col.  
C. W. Post College  
University of Calgary  
Calif. State Poly. College  
Univ. of Calif. at Berkeley  
Univ. of Calif. at Davis  
Univ. of Calif. at Los Angeles  
Univ. of Calif. at Riverside  
Univ. of Calif. at San Diego  
Calvin College  
Camden County College  
Canisius College  
Capital University  
Carlton University  
Carnegie-Mellon University  
Carroll College - Wisconsin  
Catholic Univ. of America  
Catonsville Community Col.  
Central Bible College  
Central College of Iowa  
Central Connecticut State Col.  
Central Methodist College  
Central Michigan University  
Central Piedmont Comm. Col.  
Chapman College  
Chico State College  
Christ the King Seminary  
University of Cincinnati  
Claremont Men's College  
Clarion State College  
Clark University  
Cleveland State University  
Colby College  
Colgate University  
Columbia Union College  
Columbia University  
Concord College  
Concordia College  
Connecticut College  
Cornell University  
Curry College  
Davidson College  
Davis & Elkins College  
University of Dayton  
Defiance College  
Delaware County Comm. Col.  
Delaware Valley College  
University of Delaware  
University of Denver  
University of Detroit  
Dickinson College  
Drew University  
Drury College  
University of Dubuque  
Duke University  
East Carolina University

East Stroudsburg State Col.  
East Tennessee State Univ.  
Eastern Illinois University  
Eastern Michigan University  
Eastern Nazarene College  
Eastern New Mexico University  
Eastern Washington State Univ.  
Edinboro State College  
Eisenhower College  
Elizabethtown College  
Elmhurst College  
Elmira College  
Emerson College  
Emory University  
Emory & Henry College  
Erie Community College  
Eureka College  
Fairfield University  
Fairleigh-Dickinson Univ.  
Ferris Institute  
Ferris State College  
Ferrum College  
Findlay College  
Flint Community College  
Florida Presbyterian College  
Florida Technological Univ.  
Fort Hays Kansas State Col.  
Fort Wayne Bible College  
Franconia College  
Franklin College  
Franklin College  
Franklin & Marshall College  
Franklin Pierce College  
Frostburg State College  
Furman University  
Gannon College  
Geneva College  
George Washington University  
Gettysburg College  
Glenville State College  
Gonzaga University  
Graham Junior College  
Grand Valley State College  
University of Guelph  
Gustavus Adolphus College  
Hamline University  
Hampden-Sidney College  
Harding College  
Haverford College  
Heidelberg College  
Hendrix College  
Hiram College  
Hobart & Wm. Smith College  
Hofstra University  
Holy Cross College  
Hope College  
Howard University  
Hudson Valley Community Col.  
Husson College  
University of Idaho  
Illinois State University  
Immaculate Conception Sem.  
Indiana State University  
Indiana University  
Inter American University  
Iowa Central Community Col.  
Iowa Wesleyan College  
Ithaca College  
Jamestown College  
Jersey City State College  
John Carroll University  
John Jay College  
Johns Hopkins University  
Johnson State College  
Jones College  
Judson College  
Juniata College  
Kalamazoo College  
Kansas State Teachers Col.  
University of Kansas  
Kearney State College  
Keene State College  
Kendall College  
Kent State University  
Kenyon College  
Keuka College  
Kirtland Community College  
Kutztown State College  
Lafayette College  
LaGuardia Community College  
Lake Forest College  
Lake Superior State College  
Lakeland College  
Lambuth College  
Lane College  
Lane Community College  
LaSalle College  
LaVerne College

Lawrence University  
Lehigh University  
LeMoine College  
Lenoir Community College  
Lewis College  
Lewis & Clark College  
Lindenwood College  
Linfield College  
Livingston College of Rutgers  
Long Island Univ. at Brooklyn  
Long Island Univ. at Southampton  
Loras College  
Loretto Heights College  
Los Angeles Harbor College  
Louisburg College  
Louisiana Polytechnic Institute  
University of Louisville  
Loyola University at Chicago  
Loyola University at New Orleans  
Lubbock Christian College  
Lycoming College  
Lyndon State College  
Macalester College  
Macomb Community College  
MacMurray College  
University of Maine at Fort Kent  
University of Maine at Orono  
Manhattan Christian College  
Manhattan College  
Mankato State College  
Mansfield State College  
Marietta College  
Marist College  
Marquette University  
Mars Hill College  
Mary Grove College  
University of Maryland  
Massasoit Community College  
McMaster University  
Memphis State University  
Mercy College of Detroit  
Messiah College  
Michigan State University  
Michigan Technological Univ.  
Midwestern College  
Millersville State College  
Milton College  
Milwaukee Area Technical Col.  
University of Minnesota  
Mississippi Gulf Coast Jr. Col.  
University of Mississippi  
University of Missouri at Columbia  
University of Missouri at Rolla  
Mitchell College  
Mohawk Valley Community College  
Monmouth College of Illinois  
Monmouth College of New Jersey  
Montana State University  
Montclair State College  
Moody Bible Institute  
Moorhead State College  
Mokavian College  
Morris Harvey College  
Mount Allison University  
Mount Hood Community College  
Mount Marty College  
Mount St. Mary's College  
College of Mount St. Vincent  
Muskingum College  
Nasson College  
Nathaniel Hawthorne College  
New College  
University of New Brunswick  
New Hampshire College  
New Mexico Inst. of Mining  
New Mexico State University  
City College of New York  
Bernard Baruch Col of CCNY  
Brooklyn College of CUNY  
Hunter College of CUNY  
Kingsborough College of CUNY  
Lehman College of CUNY  
New York Institute of Technology  
State Univ. of N.Y. at Albany  
State Univ. of N.Y. at Brockport  
State Univ. of N.Y. at Buffalo  
State Univ. of N.Y. at Cobleskill  
State Univ. of N.Y. at Cortland  
State Univ. of N.Y. at Fredonia  
State Univ. of N.Y. at Genesee  
State Univ. of N.Y. at Morrisville  
State Univ. of N.Y. at Oswego  
State Univ. of N.Y. at Plattsburg  
State Univ. of N.Y. at Potsdam  
State Univ. of N.Y. at Stony Brook

State Univ. A&T Col. at Canton  
State Univ. A&T Col. at Delhi  
State Univ. A&T Col. at Farmingdale  
New York University, Univ. Heights  
New York University, Washington Sq.  
Niagara University  
North Carolina A&T University  
Univ. of N.C. at Asheville  
Univ. of N.C. at Chapel Hill  
Univ. of N.C. at Charlotte  
Univ. of N.C. at Greensboro  
Univ. of N.C. at Raleigh  
North Carolina State University  
North Dakota State University  
Northeastern Illinois University  
Northern Arizona University  
Northern Essex Community College  
Northern Illinois University  
University of Northern Iowa  
Northern Michigan University  
Northland College  
North Park College  
Northwest Mississippi Junior Col.  
Northwest Missouri State College  
Northwestern Michigan College  
Northwood College  
University of Notre Dame  
Oakland University  
Occidental College  
Ocean County College  
Oglethorpe College  
Ohio State University  
Ohio University  
Oklahoma Christian College  
Oklahoma State University  
Oklahoma Military Academy  
Olivet College  
University of Ottawa  
Pace College  
Pacific University  
University of the Pacific  
Panhandle A&M College  
Paterson State College  
Pennsylvania St. U. at Hazleton  
Pennsylvania St. U. at McKeesport  
Pennsylvania St. U. at Middletown  
Pennsylvania St. U. at Univ. Park  
University of Pennsylvania  
Peru State College  
Philander Smith College  
Univ. of Pittsburgh at Bradford  
Univ. of Pittsburgh  
Plymouth State College  
Point Park College  
Portland Community College  
University of Portland  
Pratt Institute  
Princeton University  
Principia College  
Providence College  
P.S.I. Business School  
University of Puget Sound  
Furdue University  
Queens College  
Queensborough Community College  
Quinnipiac College  
Ramapo College  
University of Rhode Island  
Rice University  
Richmond Technical Institute  
Ricks College  
Rider College  
Ripon College  
Roanoke College  
Rochester Institute of Technology  
University to Rochester  
Rockford College  
Rockhurst College  
Roger Williams College  
Rollins College  
Roosevelt University  
Rutgers University  
Rutgers University at New Brunswick  
Rutgers University at Newark  
St. Ambrose College  
St. Anselm's College  
St. Bernard College  
St. Bonaventure University  
St. Francis College in Maine  
St. Francis College in Penna.  
St. John Fisher College  
St. John's University  
St. Joseph's Univ. in Philadelphia  
St. Joseph's Univ. in Calumet  
St. Joseph's Univ. in Rensselaer  
St. Lawrence University  
St. Louis University  
St. Lukes University

St. Mary's College in California  
St. Mary's College in Minnesota  
St. Michael's College  
St. Norbert College  
St. Olaf College  
St. Thomas Aquinas College  
St. Vincent College  
Salem College  
Salisbury State College  
San Diego State College  
School of the Ozarks  
School of Visual Arts  
University of Scranton  
Seattle Pacific College  
Shaw University  
Shimer College  
Shippensburg State College  
Simpson Bible College  
Skidmore College  
Slippery Rock State College  
University of the South  
University of South Carolina  
South Dakota State University  
Southern Connecticut State Col.  
Southern Illinois University  
Southern Methodist University  
Univ. of Southern Mississippi  
Southern Technical Institute  
Southwood College  
Spring Garden University  
Springfield College  
Springfield Technical Comm. Col.  
Staten Island Community College  
Sterling College  
Stevens Institute of Technology  
Stonehill College  
Susquehanna University  
Swarthmore College  
Syracuse University  
Taylor University  
Temple University  
Temple University, Ambler Campus  
Tennessee State University  
Tennessee Technological University  
Texas Technological University  
Univ. of Texas at El Paso  
Thiel College  
University of Toledo  
Towson State College  
Transylvania University  
Tri State College  
Trinity College  
Tufts University  
Tusculum College  
Union College in New Jersey  
Union College in New York  
U.S. Air Force Academy  
U.S. Military Academy at West Point  
Unity College  
Upper Iowa College  
Upsala College  
Utica College  
Vanderbilt College  
Vassar College  
Vennard College  
Vermont Technical College  
University of Vermont  
Villanova University  
Virginia Commonwealth University  
University of Virginia  
Virginia Wesleyan College  
Walla Walla College  
Washington & Jefferson College  
Washington University in St. Louis  
Washtenaw Community College  
Wayne State University  
Waynesburg College  
Wesley College  
Wesleyan University  
West Chester State College  
Western Carolina University  
Western Connecticut State College  
Western Michigan University  
Western State College  
Westmont College  
Wichita State University  
Widener College  
William Patterson College  
Wilmington College in Delaware  
Wilson College  
Windham College  
Winthrop College  
Wisconsin State Univ. at Eau Claire  
Wisconsin State Univ. at Oshkosh  
University of Wisconsin  
Yale University



LPB Inc.  
520 Lincoln Highway, Frazer, Pa. 19355 (215) 644-1123

## EFFICIENT AND RELIABLE CARRIER CURRENT TRANSMITTER OPERATION

This note attempts to be extremely practical and applied, using the example of a 20-watt carrier current broadcast transmitter for specifics and numbers. The problem and the manner of solution also applies to all other carrier current transmitters.

### I TROUBLE SHOOTING PROCEDURES

The entire broadcasting system is a chain of many links, all operating in series. The old proverb about a chain being only as strong as its weakest link certainly applies. When a problem in system operation arises, you must examine the several links of the chain to isolate that one which is at fault. When in doubt, it is important to check *each link*, to convince yourself that it *is* or *isn't* the problem. This is a matter of philosophy of logical troubleshooting procedures, but it is of utmost importance.

Regarding your transmitter, you *must* have the facilities to make basic verification of the final inspection report statements of the transmitter operating parameters, whenever any question arises. That is, you must have the capability to make at least a gross determination of the performance of the equipment. To do this should be a periodic procedure, to maintain quality and continuity of broadcasting. Perhaps most important is the basic procedure of operating the transmitter into a resistive dummy load, to check RF output and verify tuning procedures. This requires that you have a dummy load. For instance, if you can't get the transmitter plate current up to a value near that shown on the final inspection report while operating into the AC power distribution system load, the first logical step is to check the transmitter operation against the checkout parameters, using a dummy load.

Next, the transmitter plus coax system, any power splitters and the impedance matching and coupling units may be checked as a sub-system, by moving the coupling unit impedance matching tap to the 50 ohm position and operating the transmitter while driving the RF power output through the cable, splitters and coupler into the dummy load connected between any one LINE connection and the NEUTRAL connection, in place of the AC power system load. This is also an excellent periodic performance checkout procedure. While doing so, try shaking all coaxial cable connections to determine if they're electrically solid.

The modulation performance of the transmitter alone, and then of the transmitter/cable/splitter/coupler sub-system, may be checked by applying the program material to the transmitter audio input and monitoring the radiation from the dummy load with a nearby receiver.

Trouble-shooting by substitution is another essential procedure. If you have any question about the performance of a component of the system (transmitter, cable, power splitter, coupler, etc.), replace it with another, which is operating satisfactorily in another location. This is another reason why spare equipment is so important. Every commercial station has a spare backup transmitter; why should you be an exception?

### II RF OUTPUT COUPLING CONSIDERATIONS

In applying a carrier current transmitter, the first and primary concern is logically that of efficiently transferring the RF output of the transmitter into the AC power distribution system. To do so with good efficiency is also to place the transmitter under operating conditions which lead to maximum transmitter reliability.

In the following, we presume that you have a transmitter and that the first concern is convincing yourself that it is operating as it should under ideal conditions, from which point we then apply it to the far-from-ideal load of the AC power distribution system.

#### A. Checking RF Output of the Transmitter

Disconnect any audio input from your transmitter, plug in the AC power cord and connect a 52 ohm dummy load to the RF output connector. Note that conventional resistors are *not* resistive at broadcast frequencies, hence, are *not* acceptable for this application. Typical commercial dummy loads are the Heathkit HN-31 "Cantenna" or the Ohmite D-101-52. The LPB T-4 Dummy Load/Decade Box is a specially designed test device, incorporating a dummy load and a capacitor decade box for optimum convenience in testing and installing transmitters.

With the dummy load connected, turn the transmitter on and allow a two or three minute warmup period, then tune for a plate current dip on the panel meter. (See the following section regarding plate current dip, if you have questions about it.) Confirm that this value is similar to that shown on the final inspection sheet supplied with your transmitter.

Later models of LPB transmitters have a plate current meter which is clearly marked with an "Operating Range", which is intended to flag the user to notice improper tuning.

Now connect the transmitter to the AC power line load through the matching and coupling unit. If an LPB T-4 Dummy Load/Decade Box has been inserted in series between the transmitter and the coupling unit (taking care to use a cable not in excess of 4 feet of length between the T-4 and the matching and coupling unit), it is only necessary to move the central lever switch to the mid-position, which connects the transmitter output directly through the test set to the coupling unit. The step now is to choose the one of five available impedance matching taps within the impedance matching and coupling unit, which give a plate current dip, reasonably mid-range on the tuning of the transmitter. It is the *position* of the resonance dip which is important at the moment, and not the *amount* of the dip. Once having positioned the dip reasonably within the tuning range (range of available adjustment, not range of scale on the meter), however, the question *then* becomes one of *amount* of dip. If the plate current dip is now below the minimum indicated by the operating range, this tells you that the power delivered from the transmitter to the AC power system is well below transmitter specification.

Very low dip plate current dips, when connected to the power system, through the matching and coupling unit, as opposed to high plate current dips when operating into a dummy load, result because of the particular AC power system looking like a resistor in series with an *inductor*. Specifically, we find typical building power systems (as measured with a General Radio 916AL Impedance Bridge, looking into the transmitter input of the impedance matching and coupling unit) can look as bad as  $50 + j500$  ohms! The only way to efficiently transfer power from the transmitter to the AC power system is to eliminate that  $+j500$  inductive component. The way to do this is to cancel it with an equal reactance capacitor. Given the advantage of an RF impedance bridge to measure the component, one can pick a similar  $-j$  (capacitor) and put it in the coupling unit in series with the transmitter input. A more practical approach, which achieves the same result, is simply to put a mica capacitor decade box in series with the transmitter output (with the T-4, switched to the third position) and juggle the capacitor until a plate current dip similar in nature to that when feeding the output of the transmitter into a dummy load is achieved.

When you do this you will get the best of three worlds! As compared to an improper match, cancelling the power line inductive property will:

1. Increase signal strength *in* the building.
2. Decrease signal strength *outside* the building
3. Increase transmitter reliability.

With the advantage of a few numbers from an LPB 20-watt transmitter, let us examine for a moment what can happen while operating into a mismatched output load:

A transmitter-to-load mismatch bad enough to result in less than 75 MA plate current means a high VSWR (Voltage Standing Wave Ratio) seen by the transmitter output. This VSWR is reflected back to the 7984 RF power amplifier tube plate circuit, multiplied by about 6.4 (as a result of the impedance matching properties of the pi network).



The properly matched transmitter puts about 34 volts RMS carrier into a 52 ohm load. A 5:1 VSWR is modest, thus  $34 \times 5 \times 6.4 = 1090$  volts RMS. Put this on top of the 330 volt DC plate voltage, plus the audio modulation peaks, remembering to multiply first by 1.4, to convert to peak AC volts, and it is no wonder that the 7984 gives up!

In the process of doing so, the high circulating currents that accompany a high VSWR cause excessive heating of the pi network output coil, thus discoloring the plexiglass upon which the coil is mounted, sometimes melting it completely. Better examine the coil in your transmitter!

If the 7984 tube internally shorts, excessive plate current will destroy the series 10 mhy RF choke and possibly the expensive modulation transformer. If the 7984 tube opens, an even more interesting phenomenon takes place. Suddenly unloading the secondary of the modulation transformer means that the swings of audio voltage there will increase greatly, probably enough to puncture the insulation and ruin the modulation transformer. Since the modulation transformer is the most expensive single component of the transmitter, the prospective repair bill and the off-the-air time should prove most unattractive. (Our new custom-made modulation transformers utilize mylar interwinding insulation to avert this type of catastrophic failure.)

It is to avoid all of this that you have chosen the proper value of mica capacitor (usually between the range of 700 pf and 7000 pf), to put in series with the output of the transmitter. This game should be played at the point of every matching and coupling unit, irrespective of your use of power splitters. If you do use power splitters, take the transmitter to each matching and coupling unit to determine the proper value of mica series capacitor and apply it there, temporarily overlooking the fact that you're overpowering the building.

#### B. Choosing the Capacitor

Once the proper value of capacitor has been determined, the selection of the *style* of the capacitor is the next hurdle. Substantial RF current flows through this capacitor, hence many standard mica capacitors will prove unstable. Ceramic capacitors are even worse. The clue is, does the capacitor heat after a few minutes of operation? It is simply necessary to find a style of capacitor which does not internally heat, for heat will cause a shift of capacity and hence of the plate current. We can give little guide for what style will not heat, except to say that the physically larger appears to be the better. Large "transmitting mica" capacitors are optimum for this application but these will never be found on the shelves of electronic parts distributors, though they are often found in abundance among the parts collection of amateur radio experimenters. We find that the typically reddish brown dipped mica capacitors are generally quite adequate if they are rated at least 1000 volts (which will be clearly stamped on the case, if it is so), because it would appear that the internal construction of these high voltage units is a bit different, probably containing lower resistivity internal connections.

If plate current dip at resonance while operating into a dummy load does not approach that shown on the inspection report or is not within the "operating range" indicated on the plate current meter, you should know that there are two possible defects within the transmitter that could cause this. The most likely is a weak 7984 RF power amplifier tube. Spares of this tube should certainly be in your stocks, so try replacing it and see if that increases the plate current at resonance. The other reason for low plate current could be inadequate RF drive from the buffer amplifier. Check to see that the neon lamp in the buffer output circuit is glowing and that the circuit is tuned to resonance. If, for instance, the 6AL11 oscillator/buffer tube or the crystal are defective, you would of course have inadequate RF drive.

#### C. Plate Current Dip Defined

As you tune your 20-watt transmitter for resonance (plate current dip), you will observe the current drop abruptly from the 150-160 AM detuned value to a *dip* value that may not be much less.

The curve below will assist you in understanding and interpreting the plate current dip. Note that when the transmitter is properly loaded, the dip at resonance is both broader and less pronounced.

If, upon tuning your transmitter, you find the plate current dip to a *low* value, but realize that this is unacceptable in operation, you may move the setting of the transmitter dial to bring the plate current up. You have just made a *complete error* and shown you have *no* understanding of plate current dip, for this is totally incorrect. One must tune the transmitter for the *dip* regardless of what it is. The next problem if the dip is too low, is that of increasing it, and we have discussed this at length in prior paragraphs.

### III TRANSMITTER OUTPUT CABLES

The number of transmitter failures which we have directly traced to an open circuit in the RF output cable is amazing. If you can't put coaxial connectors on the coaxial cable properly, there's nothing we can do to make the equipment work right.

Pomona Electronics, H. H. Smith and others make "RF patch cords" in lengths up to 5 feet of RG-58/U 52 ohm coaxial cable with UHF male style PL-259 connectors on both ends. These are particularly useful in connecting the transmitter, the T-4, the power splitter, the coupling unit, etc. You may find the several-dollar price of these seems prohibitively high, but compared to a repair bill for your transmitter, it is quite cheap. For the convenience of our customers, LPB stocks these cables.

### IV CONNECTION TO THE AC SYSTEM

We recommend that the matching and coupling unit be connected to the AC system via quick disconnect plug. If your is a single phase 220 volt system you may use a conventional clothes dryer plug and cord set which is very readily available. If your building utilizes a three phase system, you may use a three phase four-wire disconnect plug and socket, many models of which are readily available. Having your matching and coupling unit completely disconnectable from the AC system is both a safety feature and a convenience, for it is now possible for you to move it at any time you want without calling the electrician. Ask for LPB Tech Note #4 for a further discussion of connection to the power system.

We urge that your electrician provide you the connection point and whatever disconnect switch, circuit breaker or fuse he wishes. We regret to report having seen too many student installations which consisted of punching a knockout inside the power panel and running ordinary plastic insulated wires through these holes without providing any protection for the sharp edges of metal which always result. Having come to grief on a couple of these in the past, we refuse to work on any that we see and we rather roundly condemn them as basically unsafe. If you're going to do the job, take the additional time to make it safe.

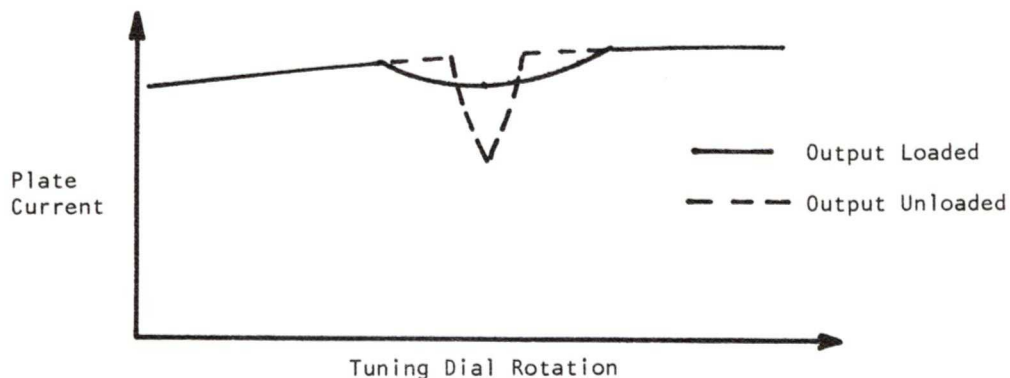

SHOWING PLATE CURRENT DIP

## CONNECTING A CARRIER CURRENT TRANSMITTER to the BUILDING ELECTRICAL SYSTEM

"Carrier current" means the use of the low voltage AC wiring system within a building as an antenna for a broadcast transmitter. These power wires aren't everything we'd like in an antenna, but they are conveniently already there, and they penetrate the building so thoroughly that any receiver can't avoid being within a few feet of the power wires. This "antenna" comes so close to the receivers that only a very small amount of broadcast energy is necessary for a strong signal.

Coupling the signal output from our small broadcast transmitter into the low voltage AC wiring requires an interface device to protect the transmitter and the AC wiring from each other, while at the same time allowing efficient transfer of energy from the transmitter into the AC wires. We call this a Matching & Coupling Unit. It draws no 60 Hz power from the electrical system, and the radio frequency energy through the device into the electrical system is only a few watts. In the interest of safety, ease of maintenance, and compliance with local electrical codes, certain minimum standards should be applied to the installation of this Matching & Coupling Unit. The small carrier current transmitter also requires a source of 117-volt, 60 Hz single phase power for its operation, and these outlets must also conform to conventional safety standards.

There is considerable variation in local electrical construction codes throughout the country, but most codes are either based on, or do not conflict with, the standards recommended by NFPA #70-1971, The National Electrical Code published by the National Fire Protection Association. This publication is also an approved American National Standard, ANSI CI-1971. The electrical installations described here are based on this, and should comply with, all local codes. However, these local codes should be investigated to ensure that your installation complies. It is important that an installation is clean, safe, and convenient for servicing and maintenance.

The following drawings show how the connection should be made in the case of 3-phase and single-phase building wiring systems.

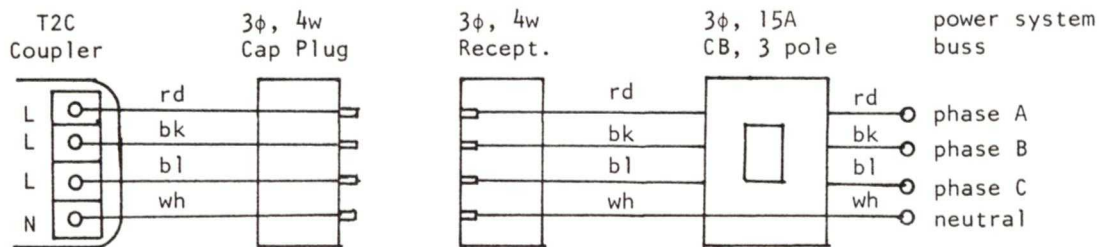

Installation on 3 phase 120/208V Y-connected System

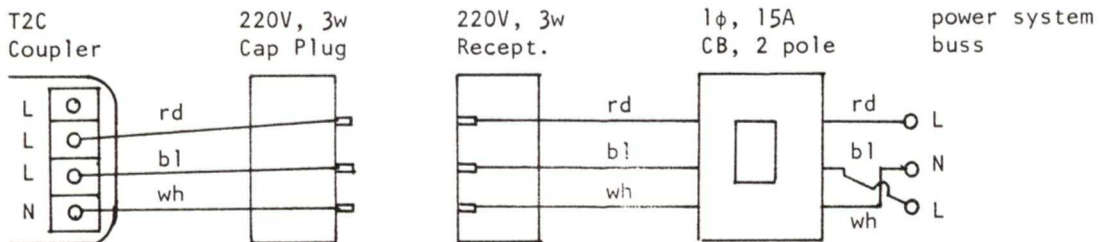

Installation on single phase 120-240V System

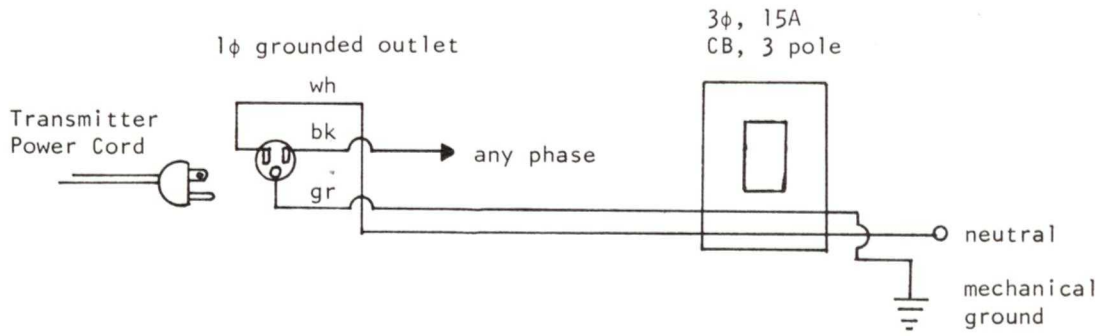

Single phase duplex outlet installation for transmitter power, 120V grounded

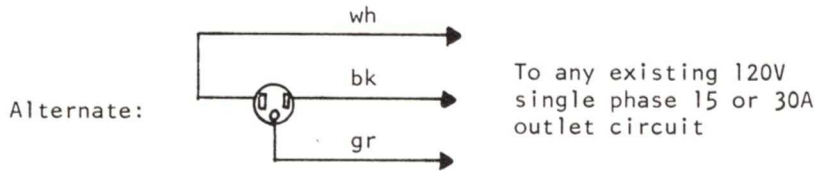

ELECTRICAL CONNECTION DIAGRAMS

Typical Equipment List

The particular manufacturers in the following list make UL-approved electrical equipment. Equipment from any manufacturer may be used, as long as it meets UL specs, and is made to NEMA specs.

3 $\phi$ 4w Cap Plug	3431-G	Harvey Hubbell
3 $\phi$ 4w Receptacle	3403-G	Harvey Hubbell
3 $\phi$ 15 amp 3-pole C.B.	QP3-B015	ITE
1 $\phi$ Grounded Outlet	5242-S	Arrow Hart
4" x 4" Outlet Box	--	any industrial standard
Duplex Outlet Box	--	any industrial standard
C.B. Box	EQ50-3	ITE
Thinwall Tubing	--	any industrial standard
Electrical Conduit	--	any industrial standard
18 ga. Electrical Wire	--	any industrial standard
Box Covers	--	any industrial standard

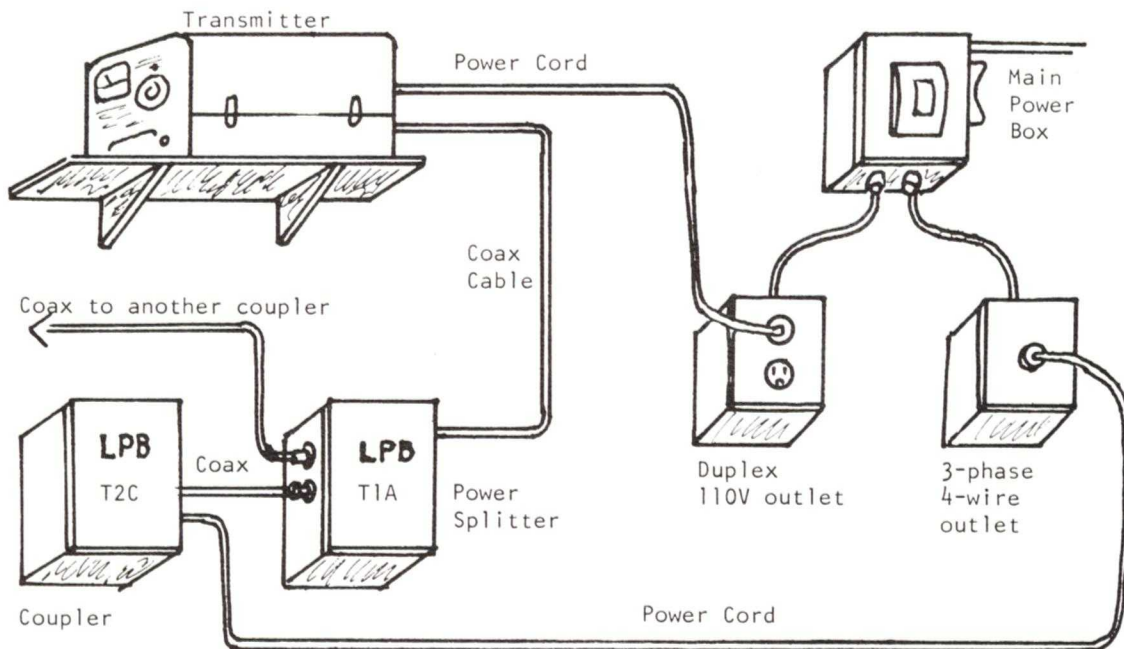

### Description of Installation

The sketch above depicts a typical installation of electrical outlets and circuit breaker for a single transmitter installation, requiring a single-phase, grounded outlet to supply power to the transmitter, and a three-phase outlet for connecting the coupling and matching unit. Outlets and the circuit breaker are installed in appropriate electrical boxes. Mechanical connectors between boxes should utilize either electrical thinwall tubing with appropriate end fittings, or 1/4-inch electrical conduit with threaded ends. Electrical lock nuts and protective fibre or plastic bushings should be used inside the boxes. The boxes should be firmly attached to the wall, using concrete nails, expansion bolts, or "molly's" as appropriate for the particular kind of wall. Internal wiring should use single conductor electrical wire of the appropriate color as shown on the electrical diagrams. The cable between the coupling and matching unit, and the cap plug should be a jacketed cable of the appropriate number and color of conductors, and should preferably be of stranded conductor construction.

## CAMPUS RADIO --- FM or AM

Establishing a broadcast station on the campus means choosing between 10-watt Educational FM and campus-limited AM. The decision is too often based upon inadequate information, since Educational FM is more widely known, and AM campus-limited or *carrier current* suffers from bad publicity. This note presents some of the considerations so that you may consider which, systems, or *if both*, are best for your situation.

### THE OUTLOOK FOR AM OPERATION

Educational FM is an F.C.C. licensed broadcast service, and is available *only* if a frequency is open in your area. To determine this, and to establish to the F.C.C. that the addition of your proposed FM station will not result in interference to those already operating, your first step will be to retain a qualified broadcast consultant. Expect his bill to be more-or-less a thousand dollars, but it will be well spent. If you are in a major metropolitan area it is very unlikely that even the cleverest consultant will be able to find you a frequency.

If your consultant is satisfied that a frequency is available, he completes your application for a *Construction Permit*, specifying transmitter make, power location, and antenna details. If the F.C.C. accepts all his information as submitted, you may expect to receive your Construction Permit in about 90 days. Then, and not before because you did not have a frequency assigned, you can order the transmitter, transmission line, antenna and tower. Expect this to cost from two to five thousand, depending upon the transmitter you choose and your antenna configuration. Plan on a three-month delivery time, since these are not production line items and your crystal will have to be *aged* by the manufacturer to meet specifications. Installation of the equipment shouldn't take long, and then you may advise the F.C.C. that you are ready to go and request *program authorization*, which should be promptly forthcoming. This timetable is probably a factor in your decision.

Your 10-watt Educational FM station will provide broadcast coverage of all listeners within a few miles radius. Just how far depends upon the antenna choice and height combined with conditions of local topography and soil conductivity. Your consultant can tell you more about this. Higher power levels than 10 watts increase this radius of listenership. Most students have FM receivers in their rooms, so count them in. What will worry your school administration, who must sign for the FM license, is what kind of program material you will broadcast to the nearby population. No college president or board of trustees can afford to overlook your potential for the presentation of one-sided or argumentative material. Nor can any college PR man long overlook what he could do with an FM station. All of this spells the possibility of faculty control, a great deal of caution, or even their refusal to go along with your FM station at all. But perhaps you have been operating a campus-limited station for a few years and have demonstrated it to be a responsible operation on the campus. That history can go a long way. And, by the way, it is our experience that the vast majority of campus stations are responsible operations.

The Commission and the trustees may let you have your Educational FM operation, and may even scrape up the few thousand dollars for the consultant and the transmission system. Unless you are fortunate to already have good broadcast studio facilities, plan several thousand more here. Five thousand is quite minimum; ten to fifteen more typical but not really elaborate. An FM studio complement can only cost more than AM, simply because you cannot "make do" when you have to pass an annual *proof of performance test*. Do not forget the annual operating budget; it is usually higher than you think! As an Educational FM'er you have no advertising income possibilities. This loss of advertising is probably more important a loss of something else than the cash. That something else is the all-too-frequently-forgotten training value that accompanies it. The sale and production of advertising is an important element of training for the real world of commercial broadcasting. In Educational FM, it isn't there. And when you sell spots to an advertiser he expects you to deliver for him; that is a monkey on your back to produce when and how promised. That is also real world training value not present in Educational FM.

Certain minimum hours of operation and regularity throughout the calendar year are also a part of the licensed station requirement, although the Commission has granted numerous waivers regarding these points to accommodate the vacation schedules of colleges.

One should also consider the future prospects of any new venture. For a 10-watt Educational FM station, the future may offer possibilities of power increases and upgrading to stereo operation. Most stations do not consider the added costs of stereo worthwhile until about 500 watts is reached, but this future power increase is again dependent upon non-interference with other broadcasters. If this type of growth is a possibility in your future, make sure that the 10-watt transmitter you buy has the specs and the F.C.C. type approval for later use in stereo and as an exciter for a higher power final power amplifier stage. Some do not qualify on this score, and not just the cheaper ones.

### THE PROSPECT FOR AM CARRIER CURRENT

Turning to a more direct look at campus-limited *carrier current* AM, recognize first that this is an *unlicensed* service ... no application forms and no wait for F.C.C. approval. Part 15.7 of the F.C.C. Rules and Regulations requires only that your system does not interfere with a licensed broadcaster and that you observe certain limits of radiated signal strength. Satisfy these requirements and the local F.C.C. men will never care about you.

Carrier current universally suffers from lack of understanding. Understanding about what it can accomplish *and* about the art and technology of how to engineer it correctly is often sadly lacking. Typical is the college that has witnessed a succession of "experts" over the years, each having spent a significant sum of money on building equipment which has ended up with an unworkable or unacceptable broadcast system. These "experts" may have been very capable people, but they simply did not have the advantage of the needed background in the art of *carrier current systems*. Many competent commercial broadcast engineers have fallen into this same trap.

Broadcast coverage with a carrier current AM system will be limited to the buildings you choose, usually dorms. This means several differences in management and programming compared to Educational FM. Your college PR man and college administration just lost interest and turned over the policy making and monitoring to the student station management. Your programming is now governed only by what the student body is interested in hearing, with no concessions needed for the local population.

We have seen a large number of colleges give up carrier current AM for Educational FM, only to later re-open the carrier current operation as a *training ground for the FM station* as well as for that uniquely campus-oriented programming capability. The AM station thus has a unique purpose on the campus *and* serves as an invaluable base for training personnel before turning them loose on the public via FM.

In carrier current AM the transmission costs are totally dependent upon the campus situation. Figure on an outside cost averaging \$350 per building to be broadcast to. The "entry fee" for the AM studio equipment is more favorable since the station can readily begin by utilizing a minimum collection of borrowed and makeshift equipment that would not have met the required FM proof of performance or the broadcasting quality that you would want for AM. This is excellent, for it allows a minimum total investment beginning upon which the value of the operation to the college community can be established before spending large sums on equipment that will be useless should the station prove of little or no value. Once the value of the station is demonstrated, there is nothing like this success to produce a flow of money for decent studio equipment.

There is also nothing like advertising to produce a large part of the annual operating budget. Advertising income from local advertising sales is limited only by your imagination and sales effort. Most carrier current stations provide their advertising sales people with incentive in the form of a commission from sales. The fact that AM can have this advertising makes it a training ground for commercial radio broadcast of which there is no other equal. Many carrier current stations bring in ten thousand per year from local advertising time sales.

We have pointed out that the programming formats of the AM and FM stations will differ, at least in part. This allows some simulcasting and some separate programming. Hours of operation for the campus-limited station can be anything from a few hours per day to continuous, depending upon available talent and interest. Many carrier current stations do provide 24 hour service to the community, either by rebroadcasting the material of a suitable commercial station when not locally originating, or by adding a minimal automation system for after-hours operation.

### SUMMARY

This brief review of the considerations of FM vs. AM is complimentary of both, recognizing that they have *differences*. It is clear that AM is probably *quicker, easier and cheaper*. It is also clear that AM is the most logical *place to start*, and that Educational FM is the growth direction to expect after the carrier current operation has been proven and stabilized.

Whatever your particular situation dictates, AM or FM, we at LPB offer you our background in educational radio for whatever assistance you wish.



## AUDIO LINES FOR COLLEGE STATIONS

Audio lines, or phone lines, are an everyday part of the operation of every college station, yet constant problems exist in their understanding, selection and use. This Tech Note will present an introduction to some of the considerations.

### LINE QUALITY

Audio lines are used in the college station to bring in remote broadcasts from away sports events, and to provide an interconnect between the control room and the transmitter. Carrier current stations, with audio lines to each of their several satellite transmitters, are particularly concerned with the cost and value received from these circuits. The following comments are particularly applicable to lines on long-term lease by the college station, often called dedicated lines.

Dedicated audio lines are available to meet a number of transmission quality specifications, described as the *class* or *rate* of the line. Perhaps the most common are:

class 6003  $\pm$  1dB from 200Hz to 3,500Hz  
 class 6005  $\pm$  1dB from 100Hz to 5,000Hz  
 class 6007  $\pm$  1dB from 50Hz to 8,000Hz  
 class 6009  $\pm$  1dB from 50Hz to 15,000Hz

These quoted class designations are peculiar to lines leased for continuous service. Different designators would apply to lines of similar specification rented for short-term use. The specification is a minimum quality guarantee. If you ask for a 6007 line from the studio in the student center to a transmitter in a dorm across the campus, the phone company will dedicate a phone pair from the campus telephone service for this and will send out a crew to measure its performance. If they find it meets 6007 specifications without need for equalization equipment, your station gets the line for about \$24 per month plus a \$30 installation fee *if you are a licensed station* (see further discussion of this point below). The total length of wire in this on-campus audio pair may only be a few thousand feet. It should be no surprise if such a line needs no equalization to be good to 8kHz. Suppose you had ordered a 6003 line, at \$10 per month plus a \$15 installation fee, and spent 30 minutes of your own time checking frequency response. One of these three alternatives would result:

1. You found it really meets 6007 or better specs. Odds *for* this are excellent for an on-campus run. Savings is \$168 per year plus \$15 installation *per audio line*.
2. You find the line does not meet your desired spec, so spend another 30 minutes with a few dollars worth of small parts to equalize the line to meet your needs. Same savings, Or,
3. You find the line does not meet your desired spec, so called back the phone company to revise the order to 6007. This costs you 30 minutes and \$15 more than if you had ordered the 6007 line at the beginning, but the difference is *now you know you need to pay* the added price.

### LINE COSTS

We have referenced some costs, and now we are getting to one of the punch lines in this phone line business. Note the reference to \$24 per month for a 6007 line *IF you are a licensed station*. A (licensed) educational FM station is considered to engage in interstate commerce, hence is subject to standard interstate tariffs on file with the F.C.C. and the I.C.C. Even so, on the *same premises* (campus) the rate between *different buildings* may be lower than the rate between buildings on *different premises* (off-campus fraternity). For the carrier current (UNlicensed) station the rates may be expected to be *even lower*, because this station is obviously engaged only in *intrastate commerce*; the F.C.C./I.C.C. interstate tariffs no longer apply. What does apply is an *intrastate tariff* which is non-standard, but is *guaranteed* to be substantially below the interstate.

If yours is a carrier current station, the heart of your problem is simply that of being billed under the *appropriate tariff*. Very naturally the member of your staff who calls the phone company to order a line will identify himself with "...radio station WXXX at Brown College...", hence it should be no surprise that the phone company personnel identify WXXX with the *interstate tariff*. These people are not knowledgeable of carrier current radio, and by the basic nature of your identification you have, unintentionally, misdirected them. Properly, carrier current stations are subject to something usually termed *Private Channels for Music Transmission in Connection with Sound Recording or Loudspeakers*.

This is under the intrastate tariff which is probably based upon airline mileage between end points, with another reduced *on premises* rate. While variable from state to state and phone company to phone company, the intrastate rates are universally more favorable to the budget of the carrier current station. If your station is being billed under the higher interstate tariff, it would not be correct to blame the telephone company. You are a rare type of user with whom they are not immediately familiar, especially when you identify yourself in the manner of a licensed radio station.

### LINE REQUIREMENTS

If a college radio station is both licensed educational FM and carrier current AM, the appropriate rate for each line must be based upon what *that particular line* is used for.

You can see that a carrier current station with several transmitters can save a lot of money being sure that it is billed at the *correct rate* and that it buys no more expensive lines than are needed. For AM carrier current, what frequency response is worth paying for? Sorry hi-fi fans, but anything beyond the 6005 line is a waste of money. The FM station, however, can justify the 15kHz response of a 6009 line.

When an audio line is required, the best approach is to locate the technical man in the phone company who is cognizant of this specialty area. Ask for the engineer who handles "radio loops," and don't be too discouraged when the first six persons you are directed to clearly do not have the least bit of understanding what you are talking about! Suddenly the right person will fall out if you shake hard enough. This can be very rewarding, for stating what your end point requirements are will invariably allow this person to tell you exactly what the line routing will be. This goes a long way toward defining the expected quality before any attempts to equalize. Based upon such a discussion, it may be best that you order the cheapest line available, which may be an undefined class below that of 6003, and do any needed equalization yourself.

Sometimes this cheapest form of on-campus line is called a *DC pair*. As the name implies, this pair would be free of any amplifiers or repeat coils so that it will pass direct current. Be aware, however, that sometimes one pays extra for a DC pair, especially if to achieve DC continuity takes extra work or special routing on the part of the phone company, or if you are going to use it for control of the transmitter *in addition to* program transmission. Dual function use of a pair increases the applicable tariff.

### EQUALIZATION

Equalization is the modification of the electrical vs. frequency properties of an audio pair to improve the high frequency transmission. Shunt capacity is the property of the line which causes loss of highs. An example is a 4 mile loop (2 miles between end points) which, when terminated with matching 600 ohm impedances at both source and load, would typically display 6dB loss at mid-band (1kHz). It would be expected to display 9dB loss at only 1.5 kHz, hence is down 3dB at 1.5kHz.

Perhaps the simplest available form of equalization would be to match the source and load both at 150 ohms. This reduces the shunt capacity effect and moves the -3dB point out to about 3.5kHz. Just changing the termination to 150 ohms is the first step in simple equalization to reduce the effects of cable shunt C. The phone company does this by inserting repeat coils at either end. These are simply 4:1 transformers to reduce the drive and loading impedances from 600 to 150 ohms.

The next step the phone company would take is to add 88mHy series inductors at about 6,000 foot intervals along the cable to cancel the capacity. In the case of 6007 and 6009 lines, smaller inductors of about 5.5mHy would be added at intervals of about 3,000 feet. As users we have no such access to the cable, other than at end points.

While it is not the objective of this note to present a complete discussion of equalization, the following passive equalizer circuit is one that may be added to the load end of the audio pair:

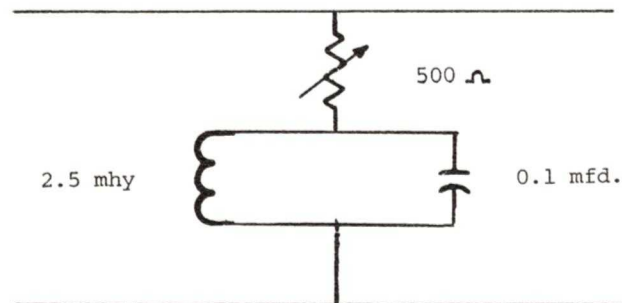

This equalizer is designed to maintain good response out to about 8kHz. This is accomplished by adding mid-band attenuation to bring down the mid-band response to equal that of the high end. This means that all passive equalizers, of necessity, increase overall line losses. Be sure the equipment on the other end of your audio line has the reserve gain to be able to work with the added loss.

The procedure for adjusting the equalizer is quite simply as follows: 1) Set R at maximum. 2) Place an isolation pad of at least 6dB between the drive source and the line input to eliminate any erroneous readings due to line impedance vs. frequency effects. 3) Measure the line loss at 8kHz. 4) Set the generator to 1kHz. 5) Adjust R for the same 1kHz loss as measured at 8kHz.

#### INPUT LEVELS

The standard input level to audio pairs is +8dBm (6.3mW of sine wave power or 1.94v RMS) at the input connection point. In almost all broadcast audio consoles this corresponds to the VU meter reading 0 VU. Beyond this input level one must expect crosstalk into other pairs in the same cable. Even at +8dBm crosstalk is sometimes experienced on non-equalized pairs (the mid-band is not attenuated, as described above), hence input levels must be reduced, perhaps to as low as 0dBm.

#### PRESERVATION OF THE PAIR

How many college stations have returned from summer vacation to find no audio pair remaining between the studio and their transmitters! The problem is simple; idle circuits were presumed by the phone company technician to be no longer in use and were disconnected for other requirements. The solutions are also simple: 1) Never leave a line unterminated, always connect a 10K ohm resistor across the load end so that you and the phone company "find something there" and can make continuity measurements whenever questions arise. 2) Over the summer months place a 0dBm level of standard tone frequency, say 1kHz, on your lines to let everyone know they are in service. A one-frequency tone generator for this is a very simple project.

**CONSULTING SERVICES**  
**for**  
**LIMITED AREA BROADCASTING**

Why Consulting Services?

Out of respect for the monetary limitations of our college customers, our products are priced with no markup for field assistance. Our instruction manuals, combined with specialized assistance via mail and telephone, allow most of our customers to hold cost to a minimum by accomplishing their own installation. We are pleased to provide equipment and installation recommendations based upon a review of information describing your particular situation.

Where the area is particularly large or unusually arranged, when important information about the nature of the electrical distribution may be unavailable, or when technical time and talent are short, our on-site technical services may be highly desirable. As is universal to the radio industry, this detailed consulting engineering service is not provided as a part of the sale price of the equipment.

Our Qualifications

LPB, Inc. is prepared and qualified to provide assistance to any desired extent. The talents of our staff include first class commercial radio telephone licensees with over twenty-five years of continuous national activity in limited area AM broadcasting. We have provided consulting services to many colleges, agencies of the U.S. Government and a host of different types of institutions. We have applied over 14,000 pieces of equipment throughout the world since 1960.

What Do You Get?

A day or two of consulting services at your location can provide an exacting analysis of equipment requirements and applications as a result of actual tests and demonstration transmissions. This also demonstrates the quality and uniformity of broadcast signal which the limited area technique and our equipment can provide.

**LPB**

Frequently, an on-site analysis results in the application of more economical equipment than would likely have been suggested from a mail review of your requirements. A visit also allows specific training of your technical staff about the techniques of limited area broadcasting within the framework of your specific situation and requirements.

Within a few days of our return, we shall furnish you a written report of our services and recommendations for your records.

### Costs Involved

Our services are available at \$250.00 per man day, plus actual travel and living expenses. The daily fee applies for each calendar day of a visit to your location and for the necessary travel requiring the absence of our engineer from his office. A one-day minimum fee shall apply. Our travel is by the most practical means available, and we strive to keep costs to a minimum.

Be aware that we shall expect you to pay for these services promptly after the visit because the travel costs and the engineer's salary will have already been paid by LPB.

### Here's What YOU Must Do

When we visit, we shall bring complete test transmission equipment whose performance has been previously measured; hence the results of test applications can be positive recommendations. These tests will require access to your AC power distribution panels and power transformers and are best preceded by discussions with your electricians about the power systems. Utilizing tape recorded program input material, you will hear exactly what broadcasting will sound like in your buildings.

Our visit should be planned to coincide with the time at which prompt access is available to your buildings to minimize your expenses. For you to derive maximum benefit, your technical staff should also be available for assistance and instruction continuously throughout our visit.

11/76

# LPB

LPB Inc.  
520 Lincoln Highway  
Frazer, Pa. 19355  
(215) 644-1123

# LPB BROADCAST EQUIPMENT PRICE LIST

1 March 1977  
(\*rev. 10/77)

## AUDIO EQUIPMENT

model	description	price
<b>CONSOLES:</b>		
S-9B	4-Channel Mono Console (add \$125 for step attenuators)	\$ 745.00
S-12	5-Channel Stereo Console	2,375.00
S-13C	8-Channel Mono/Stereo Dual Console	3,695.00
S-14A	5-Channel Mono Console	1,675.00
S-15A	8-Channel Dual Output Mono Console	2,595.00
S-20	10-Channel Dual Output Stereo Console (add \$75 for mono mixdown)	4,395.00
S-21A	10-Channel Dual Output Mono Console	3,395.00
S-21B	10-Channel Dual Output Mono Console for 10 microphone capability	3,495.00
<b>AMPLIFIERS:</b>		
S-1A	11-Channel Audio Distribution Amplifier	\$ 355.00
S-2	Audio Compressor/Limiter Amplifier (specify AM or FM model; add \$35 for proof-of-performance mod.)	375.00
<b>TRANSCRIPTION EQUIPMENT:</b>		
S-6A	Dual Channel/Stereo Turntable Equalizer/Preamplifier, unbalanced output	\$ 160.00*
S-6AT	Dual Channel/Stereo Turntable Equalizer/Preamplifier, transformer balanced	185.00*
S-7	12" 3-speed Professional Synchronous Turntable	254.00
S-8A	12" Professional Tone Arm	65.00
S-8AH	Extra Head Shell for S-8A Tone Arm	5.00
<b>STUDIO FURNITURE SYSTEMS:</b>		
dj-5A	Single-table quick-assembly system, 56" x 24" top, with turntable cutouts	\$ 200.00*
dj-10	Modular Studio Furniture, purchased separately:	
C-1/S	Single Turntable Cabinet, 29" high (if purchased without turntables, add \$10 for cutout)	190.00
R-1	Riser Base, to make above C-1/S 40" stand-up operation height	35.00
C-2/S	Double Turntable Cabinet, 29" high (if purchased without turntables, add \$10 for each cutout)	290.00
R-2	Riser Base, to make above C-2/S 40" stand-up operation height	65.00
T-1/S	Console Table, 88" x 26" top, with 29" legs	160.00
T-1/H	Console Table, 88" x 26" top, with 40" legs for stand-up operation	190.00
T-2/S	Console Table, 66" x 26" top, with 29" legs	130.00
T-2/H	Console Table, 66" x 26" top, with 40" legs for stand-up operation	160.00
H-1	Equipment Hutch	160.00
<b>CONSOLE ACCESSORIES AND SPARES:</b>		
LM-1	Luxo Spring-Balanced 41" Microphone Boom (specify clamp or flange mount)	\$ 33.00
LM-3	Luxo Spring-Balanced 56" Microphone Boom (specify clamp, flange or wall mtg) (Special springs available to support heavy microphones; state microphone weight when ordering boom)	33.00
SA-1	LED Peak Audio Level Indicator Kit	30.00
PMP	Microphone Preamplifier plug-in for consoles	75.00
PIT	High Level Input Transformer plug-in for consoles	35.00
PLA	Line Output Amplifier plug-in for consoles	75.00
PPA	Power Amplifier (Monitor or Cue) plug-in for consoles	55.00
PVR	Voltage Regulator plug-in for consoles	35.00
-	Flat rate repair charge for any console plug-in	15.00

## BROADCAST TRANSMISSION EQUIPMENT

<b>AM CARRIER CURRENT TRANSMISSION EQUIPMENT:</b>		
2-20	Carrier Current Transmission System, TX2-20 Transmitter and T-8 Power Line Interface Unit (specify required operating frequency)	\$ 750.00
LA2-20	Carrier Current Linear RF Amplifier System, LA2-20 Linear Amplifier and T-8 Power Line Interface (specify required operating frequency)	625.00*
T-1A	Power Splitter (specify number of outputs, 2 thru 5 available)	35.00
T-1S	Power Splitter, special with any ordered output ratios	50.00
T-8	Power Line Interface	125.00
-	RF Patch Cable, 3' RG-58/U with PL-259 connectors both ends	5.00
<b>EDUCATIONAL FM BROADCAST EQUIPMENT:</b>		
FM-10SS	10-watt Educational FM Transmitter, solid state	\$ 2,490.00*
FM-10SS	FM Exciter (only)	2,195.00*
772	Stereo Generator for use with FM-10SS Transmitter or Exciter	895.00*
EXFM-X	Low Power Educational FM Antenna, horiz. or circular polarization, per bay	225.00

### TERMS OF SALE

Open account available to well-rated customers. Full remittance due within 30 days of shipment, add 1.5% per month service charge thereafter. Orders under \$25 must be prepaid or authorized COD shipment, otherwise a \$5 handling charge will be applied to billing. Prices subject to change without notice.

### GUARANTEE

LPB guarantees your complete satisfaction with our products and will perform any required repairs without charge for a period of one year after delivery.

# LPB<sup>®</sup>

LPB Inc.  
520 Lincoln Highway  
Frazer, Pa. 19355  
(215) 644-1123