

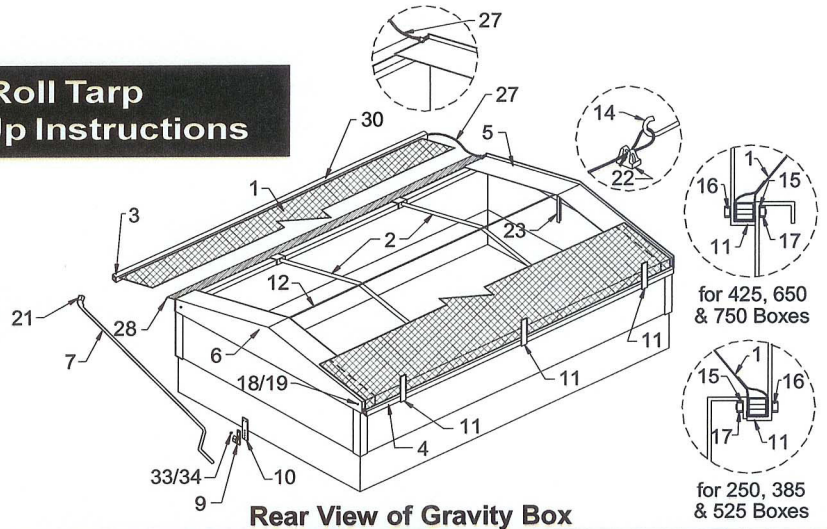

Gravity Box Roll Tarp Parts List and Set Up Instructions



for 425, 650
& 750 Boxes

for 250, 385
& 525 Boxes

PARTS LIST

#	Part #	Description	Qty	#	Part #	Description	Qty
1	250-7T	Tarp with Rivets (250-7S)	1	13	381-HB	3/8" x 1" Hex Bolt	6
1	385T	Tarp with Rivets (385SD)	1	14	384JB	3/8" J-Bolt	2
1	425T	Tarp with Rivets (425SD)	1	15	38-FW	3/8" Flat Washer	3
1	440T	Tarp with Rivets (440SD, 540SD)	1	16	382-HB	3/8" x 2" Hex Bolt	4
1	525BT	Tarp with Rivets (525SD, 525CD)	1	17	HLN-38	3/8" Hex Lock Nut	12
1	650T	Tarp with Rivets (650SD)	1	18	1434-HHMB	1/4" x 3/4" Hex Bolt (250-7S, 385SD)	18
1	750T	Tarp with Rivets (750SD)	1			1/4" x 3/4" Hex Bolt (425SD)	22
2	85TB	Bows for Tarp (250-7S)	2			1/4" x 3/4" Hex Bolt (440SD thru 750SD)	26
2	91TB	Bows for Tarp (385SD)	2	19	HLN-14	1/4" Hex Lock Nut (250-7S, 385SD)	19
2	94TB	Bows for Tarp (440SD)	2			1/4" Hex Lock Nut (425SD)	23
2	97TB	Bows for Tarp (425SD)	2			1/4" Hex Lock Nut (440SD thru 750SD)	27
		Bows for Tarp (525CD, 540SD)	3	21	14212-HB	1/4" x 2 1/2" Hex Bolt	1
2	109TB	Bows for Tarp (525SD, 650SD, 750SD)	3	22	316CC	3/16" Cable Clamp	2
3	126RT	1-1/4" Square Roll Tube (250-7S)	1	23	EPB-1	End Panel Brace	2
3	150RT	1-1/4" Square Roll Tube (385SD)	1	24	381-SB	3/8" x 1" Stove Bolt (425SD Only)	2
3	156RT	1-1/4" Square Roll Tube (425SD)	1	25	PT-93	1/2" Plastic Tube (250-7S) (105")	1
3	174RT	1-1/4" Square Roll Tube (525SD, 525CD)	1	25	PT-99	1/2" Plastic Tube (385SD) (111")	1
3	186RT	1-1/4" Square Roll Tube (440/540SD, 650SD)	1	25	PT-108	1/2" Plastic Tube (425SD) (129")	1
3	198RT	1-1/4" Square Roll Tube (750SD)	1	25	PT-123A	1/2" Plastic Tube (440SD, 540SD) (123")	1
4	120TT	1" Square Roll Tube (250-7S)	1	25	PT-117	1/2" Plastic Tube (525SD) (129")	1
4	144TT	1" Square Roll Tube (385SD)	1	25	PT-105	1/2" Plastic Tube (525CD) (111")	1
4	150TT	1" Square Roll Tube (425SD)	1	25	PT-123	1/2" Plastic Tube (650SD, 750SD) (134")	1
4	168TT	1" Square Roll Tube (525SD, 525CD)	1	27	BC-111	Bungee Cord (250-7S) (114")	1
4	180TT	1" Square Roll Tube (440SD, 540SD, 650SD)	1	27	BC-123	Bungee Cord (385SD) (120")	1
4	192TT	1" Square Roll Tube (750SD)	1	27	BC-132	Bungee Cord (425SD) (127")	1
5	8612FP	Front End Panel (250-7S)	1	27	BC-132A	Bungee Cord (440SD, 540SD) (132")	1
5	93FP	Front End Panel (385SD)	1	27	BC-141	Bungee Cord (525SD) (138")	1
5	99FP	Front End Panel (425SD, 525CD)	1	27	BC-129	Bungee Cord (525CD) (129")	1
5	100FP	Front End Panel (440SD, 540SD)	1	27	BC-147	Bungee Cord (650SD, 750SD) (143")	1
5	112FP	Front End Panel (525SD, 650SD, 750SD)	1	28	TL-123	Tightening Lip (250-7S)	1
6	8612RP	Rear End Panel (250-7S)	1	28	TL-148	Tightening Lip (385SD)	1
6	93RP	Rear End Panel (385SD)	1	28	TL-150	Tightening Lip (425SD)	1
6	99RP	Rear End Panel (425SD, 525CD)	1	28	TL-172	Tightening Lip (525SD, 525CD)	1
6	100RP	Rear End Panel (440SD, 540SD)	1	28	TL-180	Tightening Lip (540SD, 650SD)	1
6	112RP	Rear End Panel (525SD, 650SD, 750SD)	1	28	TL-180S	Tightening Lip (440SD)	1
7	CUJ-1N	Crank with U-Joint (250-7S thru 540SD)	1	28	TL-192	Tightening Lip (750SD)	1
7	CUJ-1LN	Crank with U-Joint (650SD, 750SD)	1	30	SPG-1	Square Plastic Grommet	1
9	CH-1N	Crank Holder	1	31	14STS	1/4" Self Tapping Screw	1
10	ABCH-1	Adjustable Bar for Crank Holder	1	32	BCC-1	Bungee Cord Clip	2
11	TSB-1	Tarp Stop Bracket with Sleeve	1	33	121HB	1/2" x 1" Hex Bolt	1
12	316C-126	3/16" Cable (250-7S)	1	34	12LN	1/2" Lock Nut	1
12	316C-150	3/16" Cable (385SD)	1	35	516EB	5/16" Eyebolt	1
12	316C-156	3/16" Cable (425SD)	1				
12	316C-174	3/16" Cable (525SD, 525CD)	1				
12	316C-186	3/16" Cable (440SD, 540SD, 650SD)	1				
12	316C-198	3/16" Cable (750SD)	1				

Roll Tarps for Gravity Boxes

SET-UP INSTRUCTIONS

Mounting Tightening Lip, Tarp Bows and End Panels

- 1 Place Tightening Lip on top of tightening side of grain tank and clamp ends with vise grips. Place bows between the sides of the gravity box. Align the pre-punched holes in the tightening lip, sideboards, and tarp bows. Attach the bows using 1/4" x 3/4" Hex Bolts and 1/4" Hex Lock Nuts.

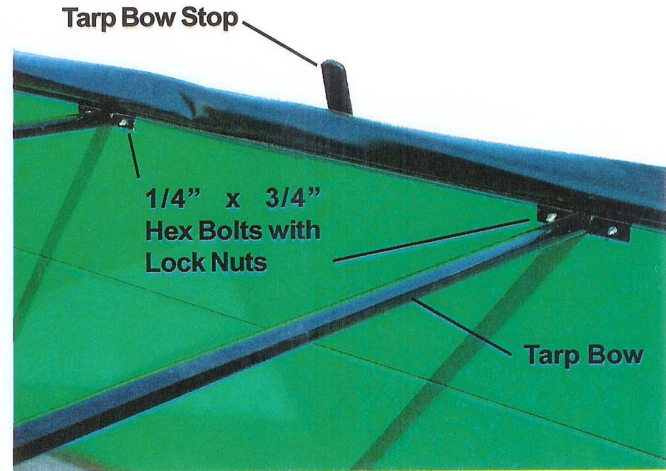
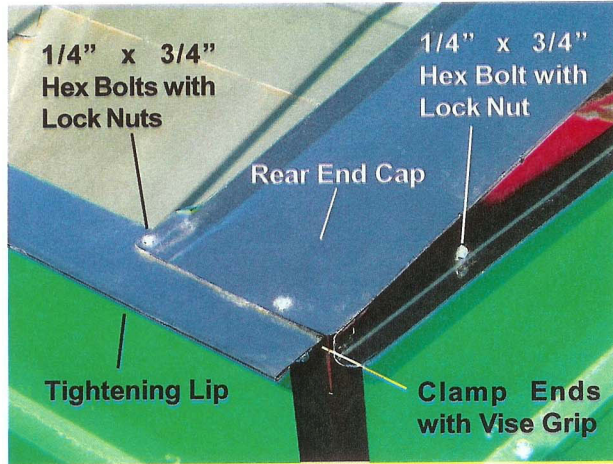

Mounting the End Panels

- 2 Position the Front End Panel (with wind lip) over the front end of the sideboards. Align and drill 1/4" holes through the side flange of the sideboards (pre-punched on end panels). Attach with 1/4" x 3/4" hex bolts and 1/4" Hex Nuts. Drill 1/4" holes through the top two holes on each end of the end panels and attach with 1/4" x 3/4" Hex Bolts and 1/4" Lock Nuts. Mount the Rear Panel to the rear end of the sideboards and attach in the same way as the front panel. Attach End Panel Brace under peak of front and rear panels. Align with sideboards of box and drill 3/8" hole and attach using 3/8" x 1" bolts and 3/8" lock nuts. (On 425-22 Gravity Box, replace the top 3/8" x 1" hex bolts on the corner with 3/8" stove bolts where tarp will rub.)

Mounting the Center Cable Supports

- 3 Place 3/8" J-Bolt under the peak of the end panel and attach using 3/8" Hex Lock Nut. Position 3/16" Cable under the end panel and run through the small hole in the peak of the panel and over the bows. Attach the cable to the J-Bolt using cable clamps. Adjust the cable tension.

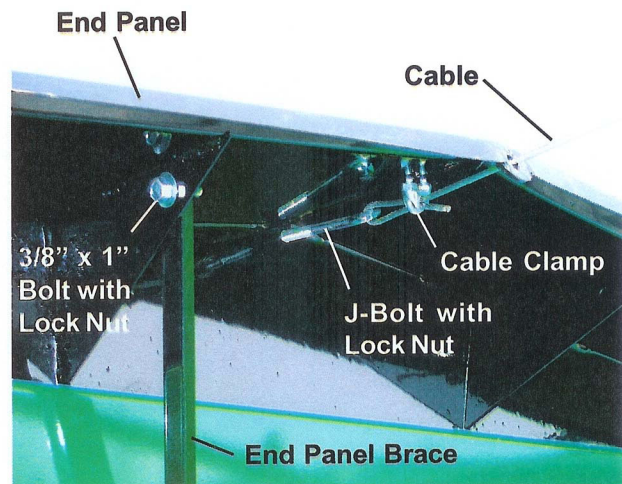

Roll Tarps for Gravity Boxes SET-UP INSTRUCTIONS

Mounting the Tarp

- 4** Lay tarp out flat (dull side up). Insert 1" Square Tie-down Tube into 3" end loop of tarp, flush to the ends. For Models 425SD, 650SD and 750SD Gravity Wagons, the square tie-down tube should be extended 2" from the edge of the front of the tarp and extend past the rear. Insert the 1-1/4" square roll tube into the 3-1/2" loop. The roll tube should be extended 1/2" from the edge of the front of the tarp and extend 8" past the rear of the tarp. Place the tarp and tubes onto the gravity box and align. Two Tarp Stop Brackets should be placed approximately 24" in from the end of the tarp (3/8" holes will have to be drilled through the tarp, 1" square tube and top sideboards). Center the third tarp stop bracket between the two end tarp stops. Tighten down the tarp stop brackets using 3/8" x 2" Hex Bolts, 3/8" Flat Washers and 3/8" Lock Nuts.

Attaching the Rivets

- 5** After the tarp is in place, drill 3/16" holes (some rivets require 1/4" holes) through the tarp and the outside wall of the roll tube at each seam and in the front and rear hems. Keep the holes 1-1/2" from each end of the tarp to allow for the Square Plastic Grommet. Drive rivets (3/16" or 1/4") into the roll tube until flush with the cap.

Installing the Bungee Cord

- 6** Roll the tarp into the covered position. Slide Bungee Cord through 1/2" Plastic Tube. Fold and clamp the end of the Bungee Cord so the cord cannot slip through the Plastic Tube. Slide the Plastic Tube (clamped end first) into the 1-1/4" Roll Tube end that is 1/2" from the end of the tarp. Slip the Square Plastic Grommet (with the chamfer end facing out) onto the Bungee Cord and drive the Plastic Grommet into the 1-1/4" Roll Tube. Secure the Plastic Grommet to the 1-1/4" Roll Tube by drilling a 1/4" Self-Tapping Screw through roll tube and into square plastic grommet. NOTE: Position the screw above or below center of the plastic grommet. Check to make sure that the tip of the screw does not go into the hole where the bungee cord travels. Attach 5/16" Eye-bolt into the wind lip on the tightening lip side. If a hole is not pre-punched in the wind lip, drill 5/16" hole in vertical wind lip of the end cap approximately 1" from the end.

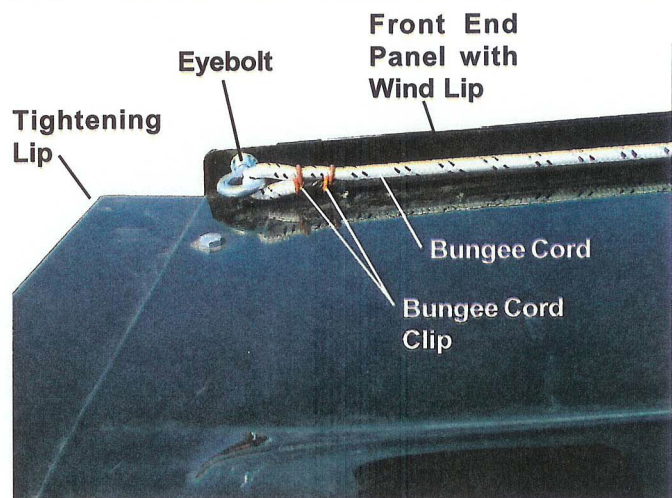
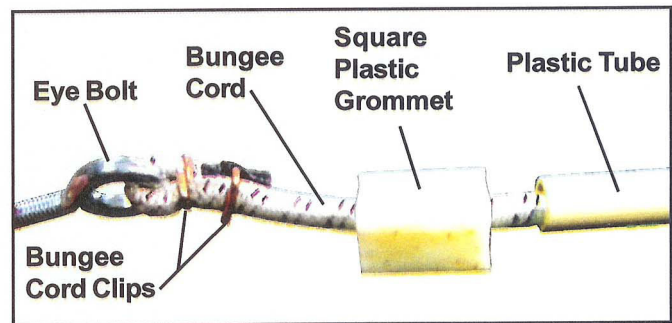
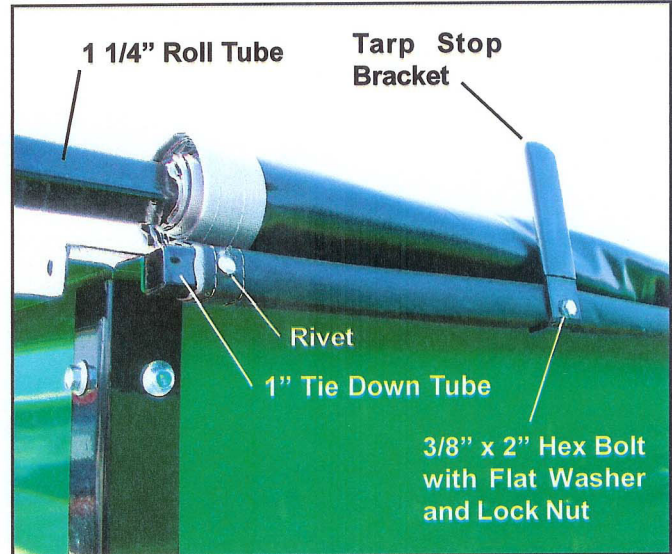

Roll Tarps for Gravity Boxes SET-UP INSTRUCTIONS

Mounting the Crank

7 Attach the Crank to the Universal Joint using 1/4" x 2-1/2" Hex Bolt and 1/4" Lock Nut. Attach the Universal Joint to the 1-1/4" Roll Tube using 3/8" x 2" Bolt and Lock Nut. Drill 3/8" holes and attach the Crank Holder Adjustable Bar to the center of the rear of the gravity box using 3/8" x 1" Hex Bolts and 3/8" Lock Nuts. (Note: Some applications may require two Crank Holders, one mounted on each side of center as shown below.) Attach the Crank Holder to the Adjustable Bar using 1/2" x 1" Hex Bolt and Lock Nut. Tighten bolt but allow the crank holder to swing freely on the adjustable bar.

