

TEC

TEC Electronic Cash Register

MA-1350-1 SERIES

Owner's Manual

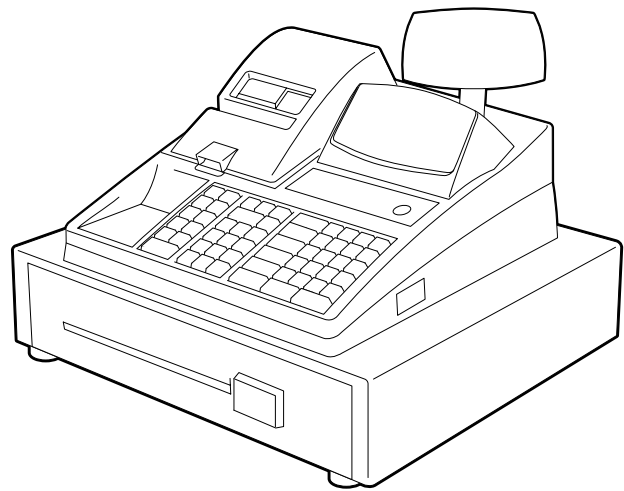

TOSHIBA TEC CORPORATION

FCC Notice

This equipment has been tested and found to comply with the limits for a Class A digital device, pursuant to Part15 of the FCC Rules. These limits are designed to provide reasonable protection against harmful interference when the equipment is operated in a commercial environment. This equipment generates, uses, and can radiate radio frequency energy and, if not installed and used in accordance with the instruction manual, may cause harmful interference to radio communications. Operation of this equipment in a residential area is likely to cause harmful interference in which case the user will be required to correct the interference at his own expense.

Changes or modification not expressly approved by manufacturer for compliance could void the user's authority to operate the equipment.

Caution : Danger of explosion if battery is incorrectly replaced.
Replace only with the same or equivalent type recommended by the manufacturer. Dispose of used batteries according to the manufacturer's instructions.

Attention

Il y a danger d'explosion s'il y a remplacement incorrect de la batterie. Remplacer uniquement avec une batterie de même type ou d'un type recommandé par le constructeur. Mettre au rebut les batteries usagées conformément aux instructions du fabricant.

The socket-outlet shall be installed near the equipment and shall be easily accessible.

Le socle de prise de courant doit être installé à proximité du matériel et doit être aisément accessible.

Safety Summary

Personal safety in handling or maintaining the equipment is extremely important. Warnings and Cautions necessary for safe handling are included in this manual. All warnings and cautions contained in this manual should be read and understood before handling or maintaining the equipment.

Do not attempt to effect repairs or modifications to this equipment. If a fault occurs that cannot be rectified using the procedures described in this manual, turn off the power, unplug the machine, then contact your authorized TOSHIBA TEC representative for assistance.

Meanings of Each Symbol



This symbol indicates warning items (including cautions). Specific warning contents are drawn inside the \triangle symbol. (The symbol on the left indicates a general caution.)



This symbol indicates prohibited actions (prohibited items). Specific prohibited contents are drawn inside or near the \circ symbol. (The symbol on the left indicates "no disassembling".)













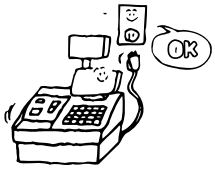

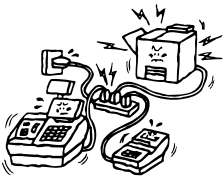





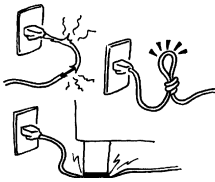

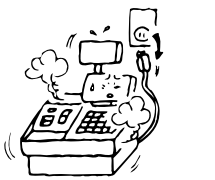

This symbol indicates actions which must be performed. Specific instructions are drawn inside or near the \bullet symbol. (The symbol on the left indicates "disconnect the power cord plug from the outlet".)

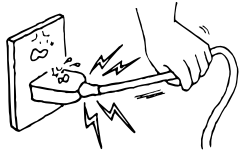

WARNING

This indicates that there is the risk of **death** or **serious injury** if the machines are improperly handled contrary to this indication.

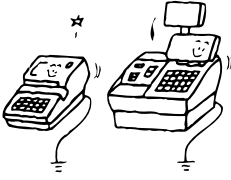
<p> Prohibited</p> <p>■ Do not plug in or unplug the power cord plug with wet hands as this may cause electric shock.</p> 	<p> Any other than the specified AC voltage is prohibited.</p> <p>■ Do not use voltages other than the voltage (AC) specified on the rating plate, as this may cause fire or electric shock.</p> 
<p> Prohibited</p> <p>■ If the machines share the same outlet with any other electrical appliances which consume large amounts of power, the voltage will fluctuate widely each time these appliances operate. Be sure to provide an exclusive outlet for the machine as this may cause the machines to malfunction.</p> 	<p> Prohibited</p> <p>■ Do not place metal objects or water-filled containers such as flower vases, flower pots or mugs, etc. on top of the machines. If metal objects or spilled liquid enter the machines, this may cause fire or electric shock.</p> 
<p> Prohibited</p> <p>■ Do not insert or drop metal, flammable or other foreign objects into the machines through the ventilation slits, as this may cause fire or electric shock.</p> 	<p> Prohibited</p> <p>■ Do not scratch, damage or modify the power cords. Also, do not place heavy objects on, pull on, or excessively bend the cords, as this may cause fire or electric shock.</p> 
<p> Disconnect the plug.</p> <p>■ If the machines are dropped or their cabinets damaged, first turn off the power switches and disconnect the power cord plugs from the outlet, and then contact your authorized TOSHIBA TEC representative for assistance. Continued use of the machine in that condition may cause fire or electric shock.</p> 	<p> Disconnect the plug.</p> <p>■ Continued use of the machines in an abnormal condition such as when the machines are producing smoke or strange smells may cause fire or electric shock. In these cases, immediately turn off the power switches and disconnect the power cord plugs from the outlet. Then, contact your authorized TOSHIBA TEC representative for assistance.</p> 

 <p>Disconnect the plug.</p>  <p>■ If foreign objects (metal fragments, water, liquids) enter the machines, first turn off the power switches and disconnect the power cord plugs from the outlet, and then contact your authorized TOSHIBA TEC representative for assistance. Continued use of the machine in that condition may cause fire or electric shock.</p>	 <p>Disconnect the plug.</p>  <p>■ When unplugging the power cords, be sure to hold and pull on the plug portion. Pulling on the cord portion may cut or expose the internal wires and cause fire or electric shock.</p>
 <p>Connect a grounding wire.</p>  <p>■ Ensure that the equipment is properly grounded. Extension cables should also be grounded. Fire or electric shock can occur on improperly grounded equipment.</p>	 <p>No disassembling.</p>  <p>■ Do not remove covers, repair or modify the machine by yourself. You may be injured by high voltage, very hot parts or sharp edges inside the machine. Unauthorized modification is prohibited.</p>



CAUTION This indicates that there is the risk of personal **Injury** or **damage** to objects if the machines are improperly handled contrary to this indication.

Precaution

The following precautions will help to ensure that this machine will continue to function correctly.

- Try to avoid locations that have the following adverse conditions:
 - * Temperatures out of the specification
 - * Direct sunlight
 - * High humidity
 - * Shared power socket
 - * Excessive vibration
 - * Dust/Gas
- Do not subject the machine to sudden shocks.
- Do not press the keys too hard. Keys will operate correctly if they are touched lightly.
- Clean the cover and keyboard, etc. by wiping with a dry cloth or a cloth soaked with detergent and wrung out thoroughly. Never use thinner or other volatile solvent for cleaning.
- At the end of the day, turn the power OFF, then clean and inspect the exterior of the machine.
- Try to avoid using this equipment on the same power supply as high voltage equipment or equipment likely to cause mains interference.
- USE ONLY TOSHIBA TEC SPECIFIED consumables.
- DO NOT STORE the consumables where they might be exposed to direct sunlight, high temperatures, high humidity, dust, or gas.
- When moving the machine, take hold of the drawer and lift the machine.
- Do not place heavy objects on top of the machines, as these items may become unbalanced and fall causing **injury**.
- Do not block the ventilation slits of the machines, as this will cause heat to build up inside the machines and may cause **fire**.
- Do not lean against the machine. It may fall on you and could cause **injury**.

Request Regarding Maintenance

- Utilize our maintenance services.

After purchasing the machines, contact your authorized TOSHIBA TEC representative for assistance once per year or so to have the inside of the machines cleaned. Otherwise, dust will build up inside the machines and may cause **fire** or **malfunction**. Cleaning is particularly effective before humid rainy seasons.

- Our maintenance service performs the periodic checks and other work required to maintain the quality and performance of the machines, preventing accidents beforehand.

For details, please consult your authorized TOSHIBA TEC representative for assistance.

- Using insecticides and other chemicals

Do not expose the machines to insecticides or other volatile solvents, as this will deteriorate the cabinet or other parts or cause the paint to peel.

OPERATOR'S GUIDE

TABLE OF CONTENTS

	Page
1. Introduction	1
2. Unpacking	1
3. Outline of Preparation Procedure Before Operating the ECR	2
4. Appearance and Nomenclature	3
5. Control Lock and Control Keys	4
Control Keys	4
Control Lock	4
6. Display	5
Numeric Display	5
Message Descriptors (Status Lamps)	6
7. Keyboard	7
Normal Keyboard Layout	7
Other Optional Keys:	7
Flat Keyboard Layout	8
Other Optional Keys:	8
Functions of Each Key	9
8. Installing the Receipt/Journal Roll	12
Installing the Receipt Roll	12
Installing the Journal Roll	14
9. Installing the Ribbon Cassette	15
10. Daily Operation Flow	16
Before Opening the Store	16
During Business Hours	16
After Closing the Store	16
11. Cashier Identifying Operation	17
1) Signing Method Cashier Sign ON & Sign OFF	17
2) Cashier Key Method (Push LED Key)	18
3) Cashier Key Method (Barrel Lock)	18
4) Cashier Key Method ([CLK] Key)	19
Cashier Reports	19
12. Training	19
Operation for Training Mode Start	19
Entries in Training Mode	20
Operation for Training Mode End	20
13. Transaction Entries	21
Displaying the Time	21
Receipt-issue/Non-issue Selection	21
Clearing Errors, or Clearing Wrong Declaration Key or Wrong Numeric Entries	22
No-sale (Exchange)	22
Received-on-Account Payment	22
Paid Out	23
Department Entries	23
PLU Entries	26
PLU Price Shift Entry	28
Preset Price Open	29

Listing Capacity Open	29
Percent Discount, Percent Charge	30
Dollar Discount	30
Vendor Coupon	31
Store Coupon	31
Item Correct (Last Line Voiding)	32
Void (Designated Line Voiding)	32
All Void (Transaction Cancel)	33
Returned Merchandise	34
Non-add Number Print	34
Subtotal Read	35
Taxable Total Read	35
Finalizing a Sale	35
Food Stamp Tender	37
Previous Balance, Charge Posting	38
Check Cashing (Cashing Non-cash Media)	39
Post-issue Receipt	40
Tax Status Modification	40
Food Stamp Modification	41
Tax Exemption	41
Manual Tax Entry	42
Sale paid in Foreign Currency	42
No-sale Exchange from a Foreign Currency to the Domestic Currency	43
Validation Print	43
Remote Slip Printer (hardware option) Operation	44
14. Paper Roll Replacement and Other Maintenance	46
Replacing the Receipt Roll	46
Replacing the Journal Roll	47
Replacing the Ribbon Cassette	48
Replenishing Ink to the Store Name Stamp	49
Manual Drawer Release and Lock	51
Removing the Drawer	51
Media Slot	52
CDC (Cash Drawer Cover; Option) Lock	52
15. In Case of the Power Failure	53
16. Troubleshooting	53
17. Specifications	57

CAUTION:

1. *This manual may not be copied in whole or in part without prior written permission of TOSHIBA TEC.*
2. *The contents of this manual may be changed without notification.*
3. *Please refer to your local Authorized Service representative with regard to any queries you may have in this manual.*

1. Introduction

Thank you for choosing the TEC electronic cash register MA-1350-1 series. This owner's manual provides a description of the functions and handling of this register and should be read carefully to ensure optimum performance. Since every consideration has been given to safety and reliability, there is no danger of damaging the machine by incorrect operation.

Please refer to this manual whenever you have any questions concerning the machine. This machine has been manufactured under strict quality control and should give you full satisfaction.

- The specifications described in this manual may be modified by TOSHIBA TEC, if necessary.
- Be sure to keep this manual for future reference.

2. Unpacking

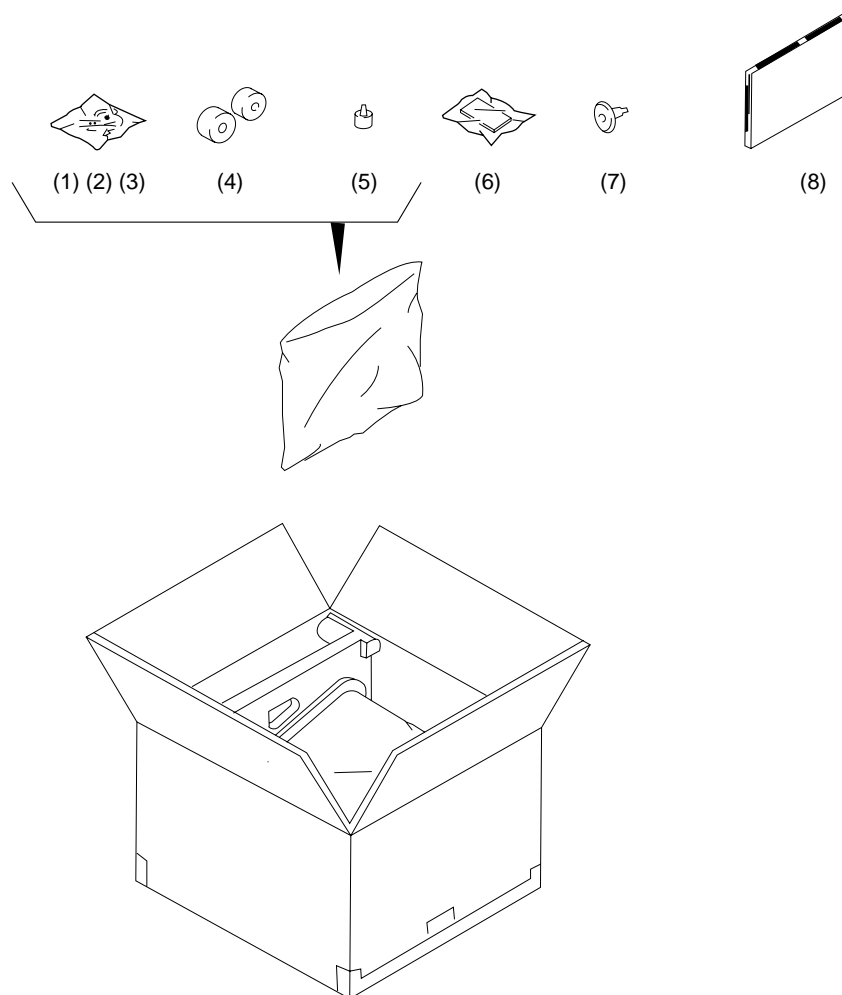

- (1) Control Key (**REG** Key, **MGR** Key, **MA** Key, **S** Key; 2 pcs. respectively)
- (2) Drawer Key (2 pcs.)
- (3) Printer Cover Key (2 pcs.)
- (4) Paper Roll 45mm x Ø50mm (2 pcs.)

- (5) Stamp Ink (1 pc.)
- (6) Ribbon Cassette (1 pc.)
- (7) Journal Take-up Reel (1 pc.)
- (8) Owner's Manual (1 pc.)

3. Outline of Preparation Procedure Before Operating the ECR

This chapter shows the outline of set-up procedure of the ECR before actually starting the ECR operation.

1 Remove the cash register from the carton, referring to **Chapter 2. Unpacking** on page 1. And take out all the parts and accessories.

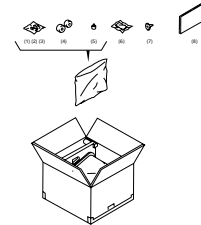

2 Remove the tapes and seals for holding parts or protecting the register surfaces.

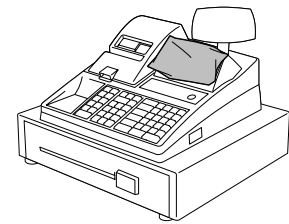

3 Plug the power cord of the register into a wall outlet. Make sure that the outlet voltage matches that of the power required for the register.

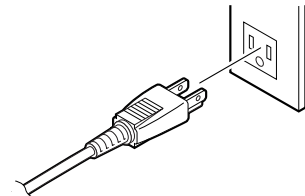

4 Insert the **REG** key into the Control Lock.

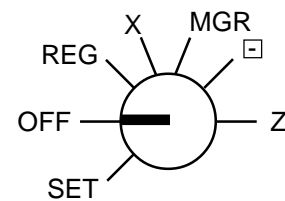

5 Turn the Control Lock to the **REG** position.

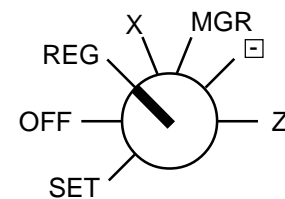

6 Install the paper roll (referring to **Chapter 8. Installing the Receipt/Journal Roll** on page 12). Also, install the Ribbon Cassette (referring to **Chapter 9. Installing the Ribbon Cassette** on page 15).

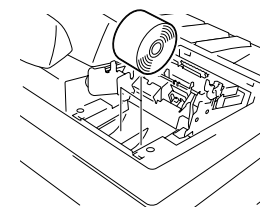

7 Before starting actual transaction entries on the register, ask your manager if you need additional setting or the programmed data needs to be changed. For programming, refer to the following Chapters in **Manager's Guide**:

- 4. Changing the Programmed Data** (page 17)
- 5. Program Data Verification** (page 41)

4. Appearance and Nomenclature

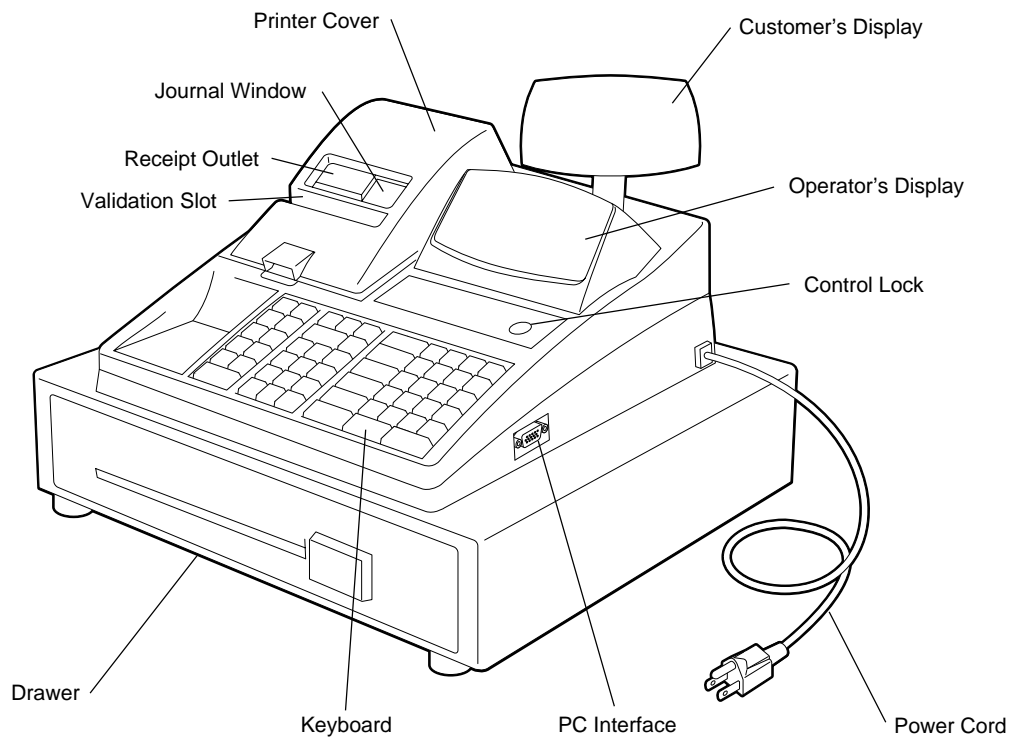

Operator's Display

Used by the operator to confirm the entry contents and the status of the register. (page 5)

Customer's Display

Provided for the customer to see the amount entered for each item and sale total. (page 5)

Receipt Outlet

The receipt for the finalized sale is issued.

Journal Window

The operator can see which items have already been entered through this window.

Validation Slot

Used to print the required item on the validation slip. (page 43)

Hardware Option

- DRS-207 (Remote Slip Printer)
- PK-2 (PLU Keyboard)
- Push LED Key Kit (Cashier Key)
- Barrel Lock Kit (Cashier Key)
- Expansion Drawer

For details, ask your TOSHIBA TEC representative.

Printer Cover

The cover for the Receipt/Journal printer.

Control Lock

It selects the type of register operations. (page 4)

Keyboard

Used to enter sale items. (page 7)

Drawer

Cash and other media are kept here. It automatically opens on finalizing a sale.

PC Interface

Used to connect a personal computer.

5. Control Lock and Control Keys

Control Keys

There are four types of Control keys: the **REG** key, the **MGR** key, the **MA** key, and the **S** key.

REG Key:

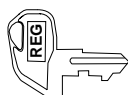

The REG key is used by the cashier or clerk who operates ordinary transaction entries. This key can access the positions of **OFF** and **REG** of the Control Lock.

MGR key:



The MGR key is used by the store manager. This key can access the positions of **OFF**, **REG**, **X**, and **MGR**.

MA Key:

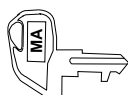

The MA key is used by the owner who will daily supervise the collection of money and printout of transactions recorded by the register. This key is also used when programming the register. This key can access the positions of **SET**, **OFF**, **REG**, **X**, **MGR**, \square and **Z**.

S Key:



The S key is used by the service person from your TOSHIBA TEC representative to access any position. To prevent programmed data and sales data from being changed or cleared by mistake, do not use this key without instructions from your TOSHIBA TEC representative.

Control Lock

The Control Lock has seven effective positions for different modes of operation, which are accessed by the appropriate Control Keys.

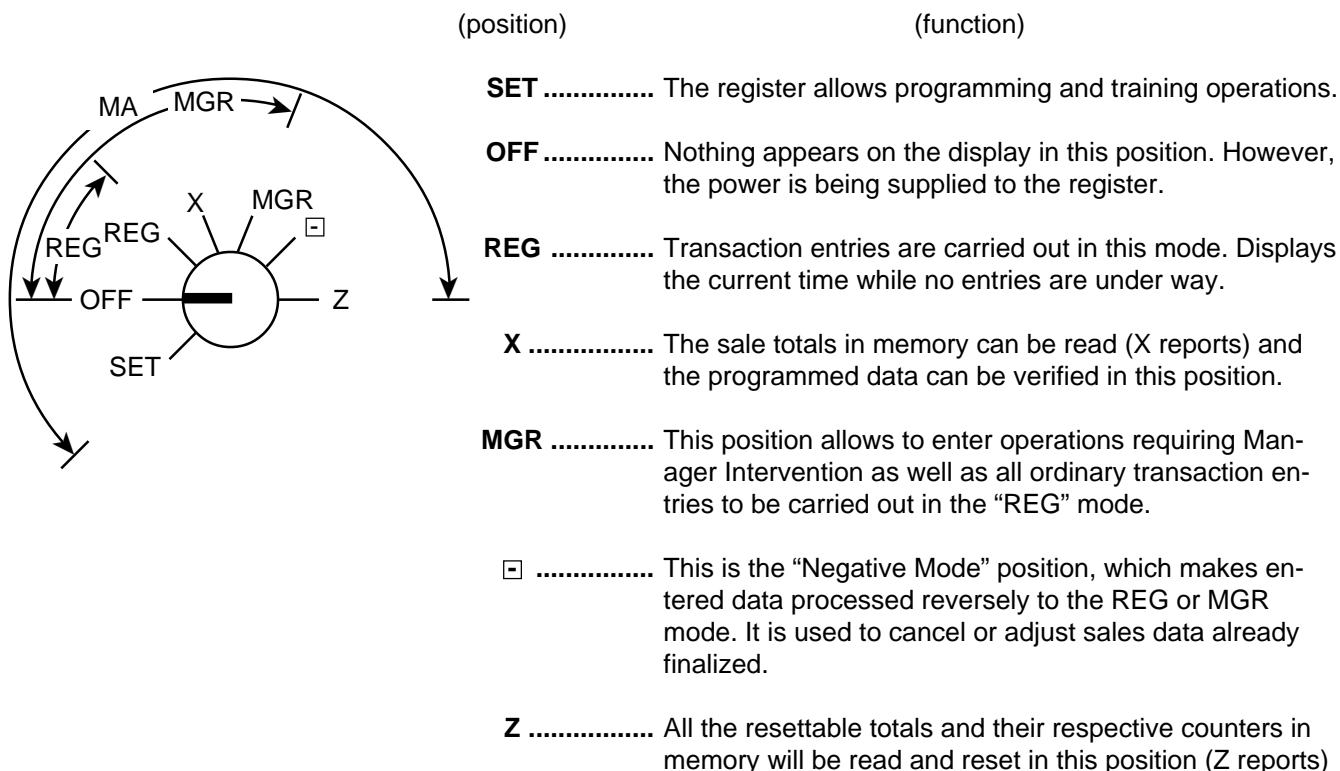

The keys may be inserted or pulled out at the "OFF" or "REG" position.

6. Display

The Operator's Display (front display) is located at the top of the register just above the keyboard. The Customer's Display may be used only as a rear display if left in the retracted position or it can be positioned for viewing at other angles by pulling it upward and turning it to the desired position. The display has two types of display portions—numeric display and message descriptors (status lamps).

Operator's Display

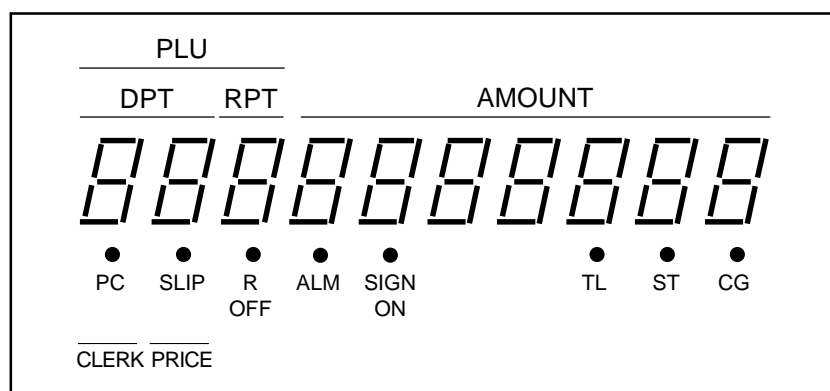

Customer's Display

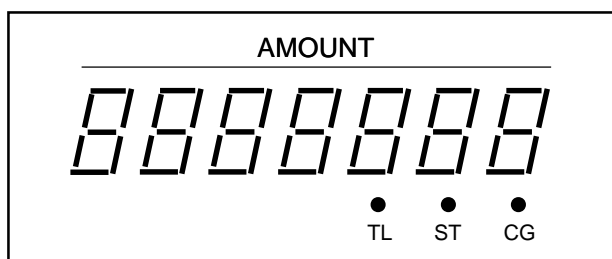

Numeric Display

AMOUNT (10 digits for total display, 7 digits for entries):

Displays the numeric data, such as amount, quantity, etc. When the obtained total or subtotal amount is 10-digit value, the **RPT** and **DPT** digits are also used for the amount display. When no entries are under way and the Control Lock is in the **REG** position, the current time is displayed.

DPT (2 digits): Displays the code which represents each Department key. It stays lit when repeating the same department entry.

RPT (1 digit): Displays the repeat count of the same item. The count is indicated from the second entry on, and only the last digit will be displayed even if the count exceeds nine.

PLU (3 digits of the DPT and RPT are used for this purpose):

Displays the PLU code when any PLU is entered. It goes out when repeating the same PLU entry, then only the **RPT** digit will be displayed for the repeat entry count. When a sale item of PLU code 1000 or more is entered, only the lowest 3 digits in the 4-digit code will be displayed.

CLERK (1 digit): Displays a cashier code instead of a department code by the program option. (Ask your TOSHIBA TEC representative.)

PRICE (1 digit): Displays PLU price shift No. instead of a department code by the program option. (Ask your TOSHIBA TEC representative.)

Message Descriptors (Status Lamps)

- PC:** Illuminates during data communication between the cash register and a personal computer.
- SLIP:** Illuminates when a validation slip is properly inserted to allow the validation print. It flickers to inform that the validation print is required when the validation compulsory status has been programmed on the last operation.
- R OFF:** Illuminates when the Receipt-OFF mode is declared by the **[LOG/RECEIPT]** key. In this condition, no receipts will be issued for a sale to be entered. To extinguish this lamp (i.e., to change into Receipt-ON mode for issuing receipts), simply depress the **[LOG/RECEIPT]** key again.
- SIGN ON:** Illuminates when a cashier signs ON if the cashier signing method has been selected.
- ALM:** Illuminates with the alarm buzzer to indicate that the last operation or numeric entry was an error. To clear the error condition, depress the **[C]** key.
- TL:** Illuminates with the total amount displayed when a sale is finalized without any amount tendered.
- ST:** Illuminates in the following operations or condition.
- The **[ST]** key is depressed, indicating that the displayed amount is subtotal.
 - The **[TXBL TL]** key is depressed, indicating that the displayed amount is taxable total.
 - The **[EX]** key is depressed, indicating that the displayed amount is the sale portion subject to the tax exemption.
 - Amount tendered is less than the sale total.
- CG:** When an amount tendering operation has been performed, this lamp illuminates with the amount of change due displayed.

7. Keyboard

The following is the standard keyboard layout, which was initially set at the factory. This register is designed to be capable of programming most of the keys at desired locations or adding keys, ask your TOSHIBA TEC representative. (For details about operations, refer to **Chapter 13. Transaction Entries** on page 21.)

Normal Keyboard Layout

LOG RECEIPT		RTN MDSE	VALID DATE	RF	JF	Department Keys 1 to 15				
#/NS	VOID		C			1	6	11	PO	RECEIPT ISSUE
FS/M	ITEM CORR					2	7	12	R/A	DOLL DISC
PR OPEN	@/FOR		7	8	9	3	8	13	VND CPN	%-
LC OPEN	AMT		4	5	6	4	9	14	STR CPN	EX
PLU			1	2	3	5	10	15	FSTL TEND	chg
			0	00	•	ST	AT/TL		CHECK TEND	

Other Optional Keys:

- Additional Department Keys

to

- (Triple Zero Key)
- (Percent Charge Key)
- (All Void Key)
- (Miscellaneous Media Key)
- (Media-coupon Key)
- (No-sale Key)
- (or (Non-add Number Print Key)
- (Open Key)
- (Tax 2 Modifier Key)
- (Tax 3 Modifier Key)
- (Taxable Total Key)

- (Manual Tax Key)
- (Previous Balance + Key)
- (Previous Balance - Key)
- (Transfer Key)
- to (Cashier 1 to 8 Keys)
- , , (Cash Payment 1 to 3 Keys)
- to (Foreign Currency 1 to 4 Keys)
- to (PLU Price Shift 1 to 3 Keys)
- (GST Modifier Key; for Canada)
- PLU Preset-code Keys

Flat Keyboard Layout

PLU Preset-code Keys								1	8	LOG RECEIPT	VOID	ITEM CORR	ALL VOID	RF	JF
								2	9	RECEIPT ISSUE	TX/M	EX	RTN MDSE	R/A	PO
								3	10	%-	C		@/FOR	chg	NS
								4	11	#	7	8	9	\$5.00	
								5	12	AMT	4	5	6	\$10.00	
								6	13	PLU	1	2	3	ST	
								7	14		0	00	.	AT / TL	

Department Keys 1 to 14

Other Optional Keys:

- Additional Department Keys

15 to 40

- 000 (Triple Zero Key)
- VND
CPN (Vendor Coupon Key)
- STR
CPN (Store Coupon Key)
- DOLL
DISC (Dollar Discount Key)
- %+ (Percent Charge Key)
- CHECK
TEND (Check Tender Key)
- PR
OPEN (Preset Price Open Key)
- LC
OPEN (Listing Capacity Open Key)
- OPEN (Open Key)
- VALI
DATE (Validation Print Key)
- #/NS (Non-add Number Print/No-sale Key)
- TX2/M (Tax 2 Modifier Key)

- TX3/M (Tax 3 Modifier Key)
- TXBL
TL (Taxable Total Key)
- TAX (Manual Tax Key)
- PB+ (Previous Balance + Key)
- PB- (Previous Balance - Key)
- TRF (Transfer Key)
- FS/M (Food Stamp Modifier Key)
- FSTL
TEND (Food Stamp Total/Tender Key)
- CUR 1 to CUR 4 (Foreign Currency 1 to 4 Keys)
- CASH3 (Cash Payment 3 Key)
- PRICE
SHIFT 1 to PRICE
SHIFT 3 (PLU Price Shift 1 to 3 Keys)
- CLERK
1 to CLERK
8 (Cashier 1 to 8 Keys)
- GST/M (GST Modifier Key; for Canada)

Functions of Each Key

KEY	FUNCTION	REFERENCE PAGE
LOG RECEIPT	Log/Receipt Key: Used for the cashier sign on/off operation when cashier signing option is selected after entering numbers. Also, used to select receipt issue or non-issue without entering numbers.	17, 21
RF	Receipt Feed Key: Used to advance the receipt roll and operated by holding it down until the paper is advanced to the required position.	-----
JF	Journal Feed Key: Used to advance the journal roll in the same fashion as the [RF] key is used for receipt roll.	-----
NS	No-sale Key: Used in the no-sale operation.	22, 43
ALL VOID	All Void Key: Used to delete all items in the current sale.	33
PR OPEN	Preset Price Open Key: Used to release the preset-price department for a manual price entry.	29
LC OPEN	Listing Capacity Open Key: Used to enter an amount which exceeds the listing capacity programmed for department keys in advance.	29
DOLL DISC	Dollar Discount Key: Used to subtract an amount from a sale.	30
RTN MDSE	Returned Merchandise Key: Used for the returned merchandise operation.	34
C	Clear Key: Used to clear a wrong entry or operation error.	22
# (or #/CID)	Non-add Number Print Key: When depressed with a prior number entry, this key is used to print the non-add number.	34
1 to 40	Department Keys 1 to 40: Used to enter department items and process the amount into appropriate departments.	23 ~ 25
%-	Percent Discount Key: Used to subtract a percent rate, preset or manually entered, from a sale or an individual sale item.	30
@/FOR	At/FOR Key: Used to enter a department or a PLU item by multiplication. Also used to auto-calculate and enter a split package price.	24, 25, 27
R/A	Received-on-Account Key: Used to register received-on-account amount.	22

KEY	FUNCTION	REFERENCE PAGE												
PO	Paid Out Key: Used to register paid out amount.	23												
PLU	PLU (Price-Look-Up) Key: Used to enter a PLU item that is linked to a department.	26, 27												
AMT	Amount Key: Used to enter a manual amount of PLU item.	26, 27												
ITEM CORR	Item Correct Key: Used to delete the last item entered within the current sale.	32, 33												
<table border="1"> <tr><td>7</td><td>8</td><td>9</td></tr> <tr><td>4</td><td>5</td><td>6</td></tr> <tr><td>1</td><td>2</td><td>3</td></tr> <tr><td>0</td><td>00</td><td>.</td></tr> </table>	7	8	9	4	5	6	1	2	3	0	00	.	Numeric Keys: Used to enter numeric data, such as amount, quantities, and code numbers. The [00] key functions the same as depressing the [0] key twice. The [.] key is used to designate the decimal point of a percentage rate or a quantity. The [000] key functions the same as depressing the [0] key three times.	-----
7	8	9												
4	5	6												
1	2	3												
0	00	.												
ST	Subtotal Key: Used to obtain a subtotal of the current transaction.	35												
TXBL TL	Taxable Total Key: Used to obtain the taxable total (the sale total including taxes due) of the current transaction.	35												
VND CPN	Vendor Coupon Key: Used to enter the amount of vendor coupons received from the customer.	31												
STR CPN	Store Coupon Key: Used to subtract the store coupon amount redeemed through a department.	31												
MISC	Miscellaneous Media Key: Used to finalize a sale as miscellaneous media.	22,35,36,39												
chg	Charge Key: Used to finalize a sale as charge.	22,35,36,39												
CHECK TEND	Check Tender Key: Used to finalize a sale as check.	22,35,36,39												
AT/TL	Cash Amount Tender / Total Key: Used to finalize a sale as cash.	22,23,35,36												
%+	Percent Charge Key: Used to add a percent rate, preset or manually entered, to a sale or an individual sale item.	30												
RECEIPT ISSUE	Post-issue Receipt Key: Used to print the receipt of a last sale completed in registration.	40												
CPN	Media-coupon Tender Key: Used to finalize a sale as media-coupon.	22,35,36,39												
VALIDATE	Validation Print Key: Used to print a required item on a validation slip.	43												
VOID	Void Key: Used to delete item(s) already entered in the current sale.	32												

KEY	FUNCTION	REFERENCE PAGE
#/NS	Non-add Number Print / No-sale Key: It functions as the [#] (or [#CID]) key and the [NS] key.	22, 34, 43
OPEN	Preset Price & Listing Capacity Open Key: It functions as the [PR OPEN] key and the [LC OPEN] key.	29
CLERK 1 to CLERK 8	Cashier 1 to 8 Keys: Used to identify each cashier who operates the register.	19
\$5.00 , \$10.00 CASH3	Cash Payment 1 to 3 Keys: Used for cash-tendering operation with the respective preset amounts. As initial setting, the amount \$5.00 is preset for the [\$5.00] key and \$10.00 for the [\$10.00] key.	36
CUR 1 to CUR 4	Foreign Currency 1 to 4 Keys: Used to finalize a sale with foreign currency.	42, 43
TX1/M to TX3/M	Tax Modifier 1 to 3 Keys: Used to reverse the tax status of required department, PLU, percent discount/charge, dollar discount, vendor coupon or store coupon entry.	40, 41
EX	Tax Exempt Key: Used to exempt designated tax (es) from the sale.	41
TAX	Manual Tax Key: Used to enter an irregular tax amount to sale total.	42
GST/M	GST Modifier Key (applicable for Canada only): Used to reverse the GST status of required department, PLU, percent discount/charge, dollar discount, vendor coupon, or store coupon entry.	40, 41
FS/M	Food Stamp Modifier Key: Used to reverse the food stamp status of required department, PLU, percent discount/charge, dollar discount, vendor coupon, or store coupon entry.	41
FSTL TEND	Food Stamp Total/Tender Key: Used to read the food stampable portion amount of a sale and to tender an amount in food stamps.	37
PB+ , PB-	Previous Balance Keys: Used to enter a previous balance in charge posting operation.	38
TRF	Transfer Key: Used to transfer an entire balance in charge posting operation.	38
PRICE SHIFT 1 to PRICE SHIFT 3	Price Shift 1 to 3 Keys: Used in PLU price shift operation.	28
PLU Preset-code Key	PLU Preset-code Keys: Each of these keys is programmed with a PLU code. Therefore, depressing those keys can directly enter PLU items corresponding to each PLU code.	26, 27

8. Installing the Receipt/Journal Roll

Installing the Receipt Roll

WARNING!

Care must be taken not to injure yourself with the paper cutter.

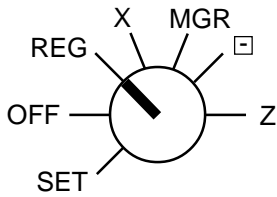

1

Turn the Control Lock to the **REG** position using a Control Key.

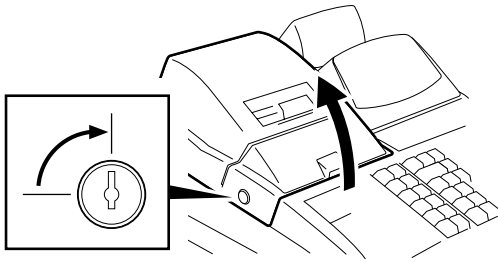

2

To remove the Printer Cover, insert the Printer Cover Key to the Printer Cover Lock, and then turn it 90° clockwise.

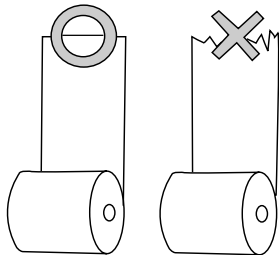

3

Cut the paper end to make it sharp.

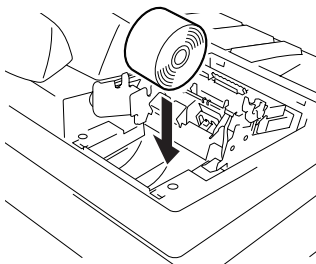

4

Place the paper roll in the outer side holder of the two roll holders.

Correct

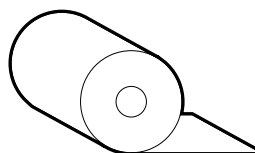

Incorrect

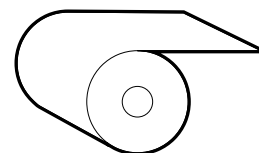

5

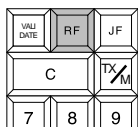
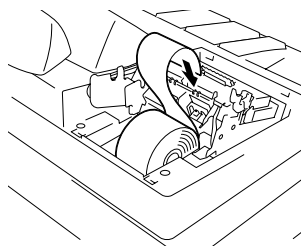

Insert the paper end into the receipt inlet behind the printer. Then, feed the paper by hand into the inside of the printer **while pressing the [RF] key** provided at the central upper side of the keyboard until about 4 inches (about 10 cm) of paper comes out of the printer.

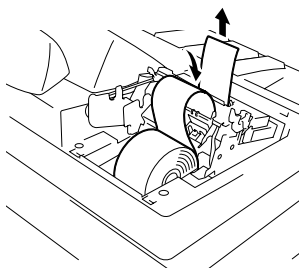

6

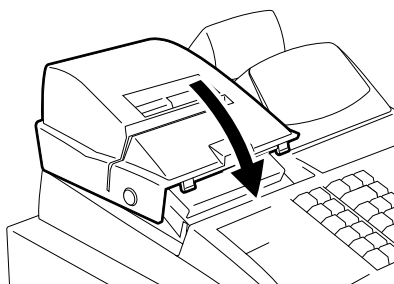

Cut the excess paper with the attached cutter, and attach the Printer Cover. After closing the Printer Cover, depress the **[/NS]** key to check print condition.

Installing the Journal Roll

1

Follow Steps 1 to 5 for “Installing the Receipt Roll” on the preceding pages, except that the paper roll should be placed inner side of the two holders and the **[JF]** key should be used for the journal roll to advance about 8 inches (about 20 cm) of paper out of the printer.

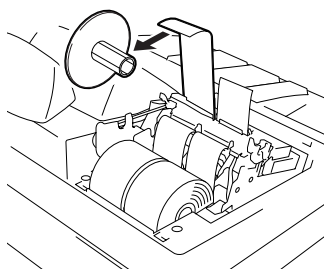

2

Insert the paper end into the slit on the Take-up Reel and wind it around the reel two or three times.

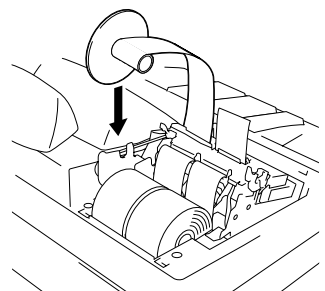

3

Set the Journal Take-up Reel into the Reel Holder.

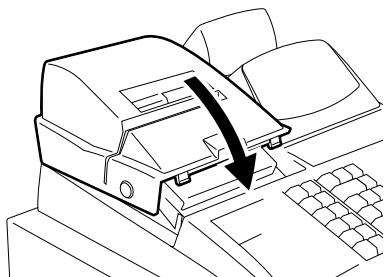

4

Attach the Printer Cover.

9. Installing the Ribbon Cassette

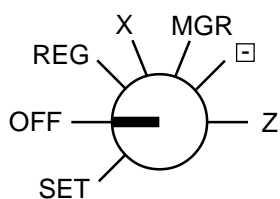

1

Turn the Control Lock to the **OFF** position.

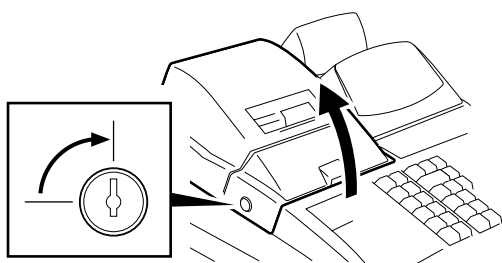

2

To remove the Printer Cover, insert the Printer Cover Key to the Printer Cover Lock, and turn it 90° clockwise.

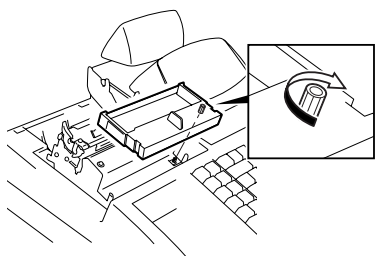

3

Install the Ribbon Cassette as shown in the figure. After installing the Ribbon Cassette, turn the knob of the Ribbon Cassette in the direction of the arrow mark several times to remove the slack on the ribbon.

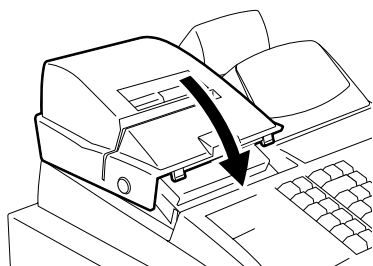

4

Attach the Printer Cover.

10. Daily Operation Flow

The following shows a typical daily operation flow on the register.

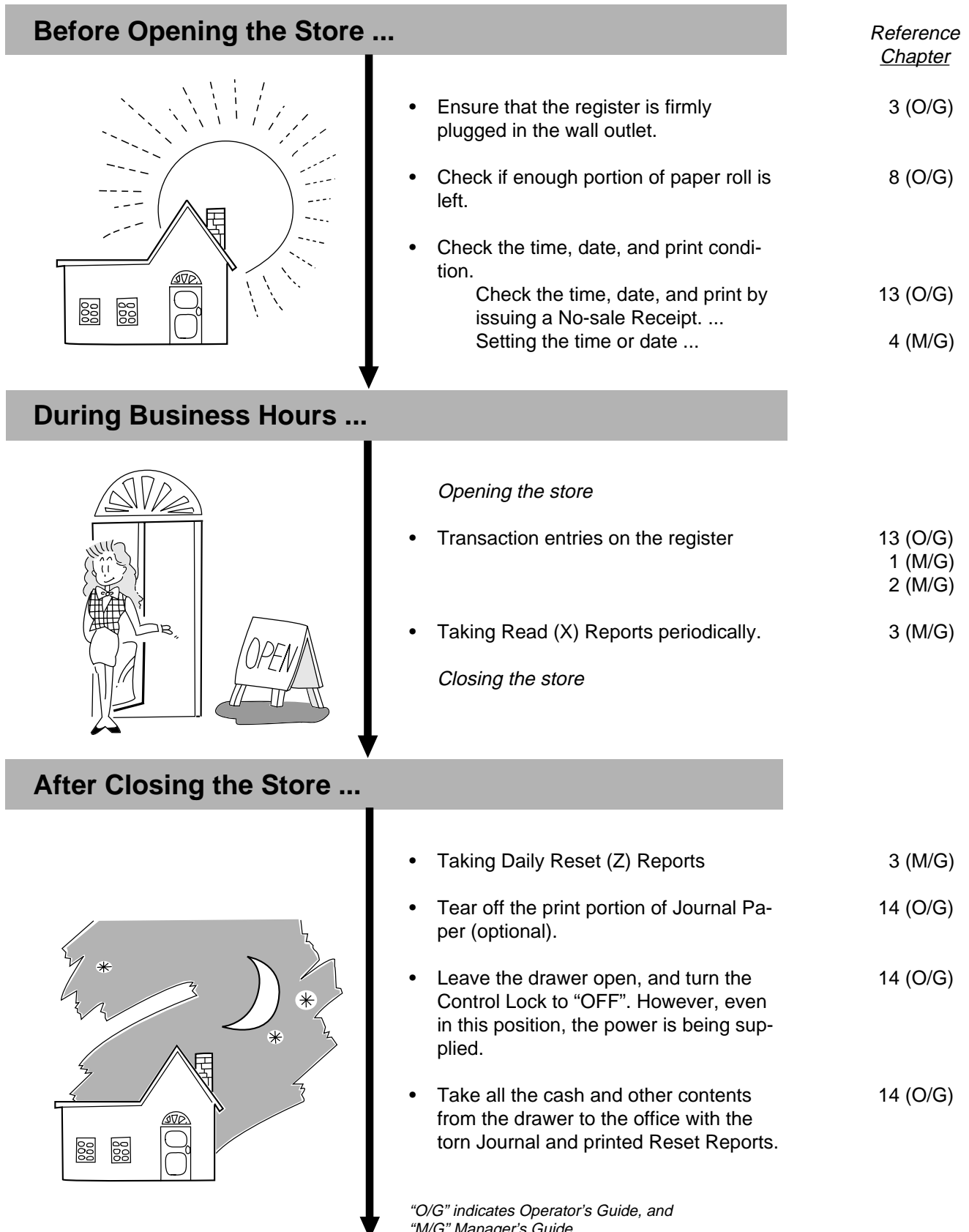

11. Cashier Identifying Operation

The register requires the cashier identifying operation for starting sales entries in initial status. However, the program option allows you to operate the register without the cashier identifying operation. For details, ask your TOSHIBA TEC representative.

The MA-1350-1 adopts one of the following cashier-identifying methods.

- 1) Signing Method, using the **[LOG/RECEIPT]** key
- 2) Cashier Key Method, using the Push LED Key
- 3) Cashier Key Method, using the Barrel Lock
- 4) Cashier Key Method, using the **[CLK]** key installed on the keyboard

Method 1) is the standard feature. To changed the cashier-identifying method from 1) to 2) or 3), appropriate program option selection is necessary as well as hardware option. (Ask your TOSHIBA TEC representative.)

1) Signing Method Cashier Sign ON & Sign OFF

A cashier needs to “sign ON” for starting transaction entries on the register and identifying the operator. The signed-ON condition is held until a “sign OFF” is operated. A cashier can sign ON only when the register is in the signed-OFF condition. A maximum of 8 cashiers can be controlled in the signing method.

Sign ON (operable in signed-OFF condition)

Use the **REG Key** to turn the Control Lock to the **REG** position. (or to **MGR** or \square using the **MGR** or **MA** key for operation by manager)

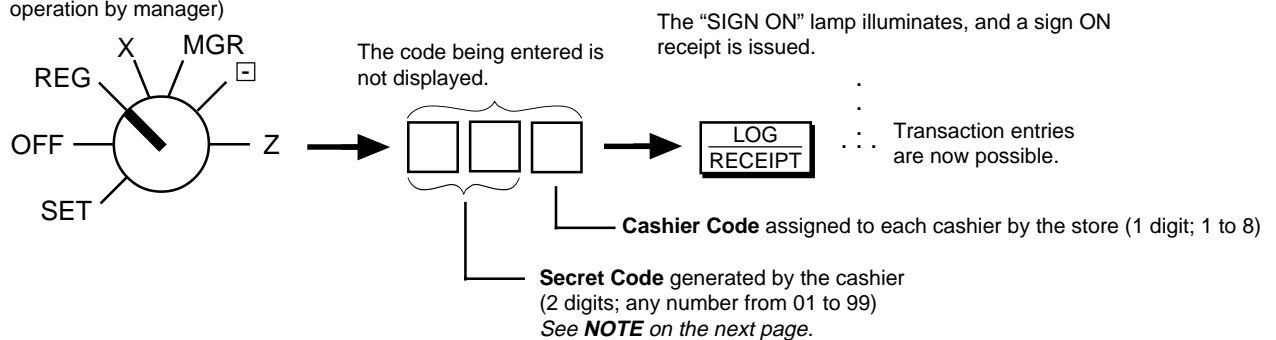

Sign OFF (operable in signed-ON condition)

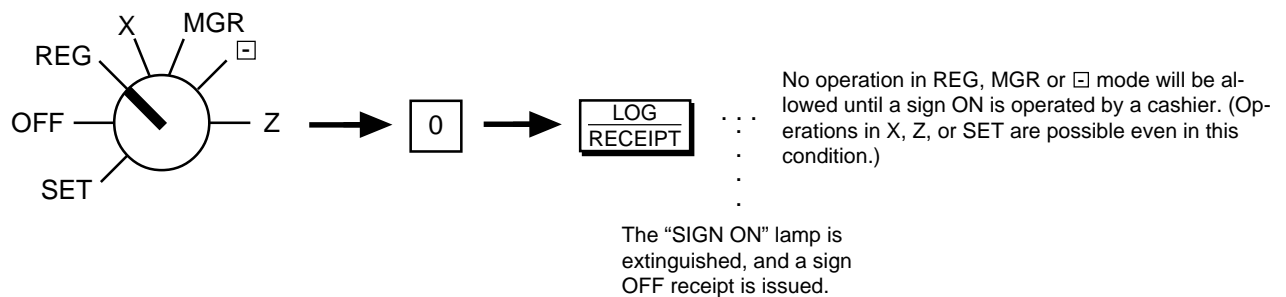

Sign ON Receipt Format

Sign OFF Receipt Format

Name of a cashier who has just signed ON is printed if the name has been programmed. If not, a cashier symbol such as "3CL" is printed here.

```

TEC STORE
1343 PEACH DRIVE
PHONE: 87-6437

Open 8:00am to 7:00pm
Closed: every Wednesday

11-28-1997      #112300

* SIGN ON *
JONES          0117 08:46TM
    
```

```

TEC STORE
1343 PEACH DRIVE
PHONE: 87-6437

Open 8:00am to 7:00pm
Closed: every Wednesday

11-28-1997      #112300

* SIGN OFF *
JONES          0118 08:46TM
    
```

- NOTES:**
1. The two-digit Secret Code portion, once entered for a cashier's Sign ON, is set in the memory of the register. The Secret Code of the same cashier is checked every time his/her Sign ON is operated until the Daily Cashier Reset Report is taken at the end of the day. Then the Secret Code is reset and a new Secret Code entry will be allowed. When the Secret Code is within the range of 01 to 09, it will be omissible to enter the preceding zero.
 2. The multi-drawer feature can be adopted on this cashier-identifying method. In this case, Drawer 1 is assigned to cashiers 1 and 2, and Drawer 2 to cashiers 3 to 8.

2) Cashier Key Method (Push LED Key)

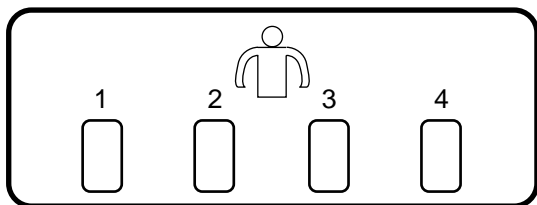

Each Cashier key (1 to 4) is assigned to each cashier. Push the assigned cashier key, and the built-in light becomes lit, indicating that the key is ON to identify the cashier. The ON status of the key will be held until another cashier key is pushed.

Sales entries will be possible only when one of these key is in the ON status (in "REG", "MGR", or "☐" mode).

The Key's ON status will not be cleared even when the Mode Lock is turned to other positions.

- NOTES:**
1. No receipts are issued on turning ON or OFF a Cashier Key. However, the cashier code (1 to 4) or cashier name is printed near the bottom of every receipt to be issued.
 2. The multi-drawer feature can be adopted on this cashier-identifying method. In this case, Drawer 1 is assigned to cashiers 1 and 2, and Drawer 2 to cashiers 3 and 4.

3) Cashier Key Method (Barrel Lock)

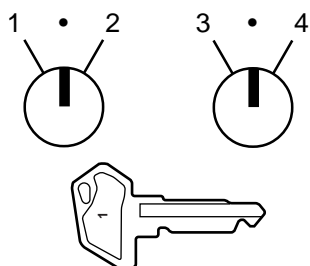

Cashier Keys 1 to 4

This method is applied when two barrel locks are installed as cashier locks. A maximum of 4 cashiers can be identified in this method.

Each key (1 to 4) is assigned to each cashier. The register will not operate in the **REG**, **MGR**, or ☐ mode unless one of these keys is inserted and turned to the position (1 to 4) corresponding to the Cashier Key No.

Each of the keys may be inserted and pulled out in the neutral position marked with a dot. When the operating cashier changes to another, the first Cashier Key must be pulled out before inserting another Cashier Key.

- NOTES:**
1. No receipts are issued on turning ON or OFF a Cashier Key. However, the Cashier Code (1 to 4) is printed near the bottom of every receipt to be issued.
 2. The multi-drawer feature can be adopted on this cashier-identifying method. In this case, Drawer 1 is assigned to cashiers 1 and 2, and Drawer 2 to cashiers 3 and 4.

4) Cashier Key Method ([CLK] Key)

A maximum of 8 cashier keys ([CLK 1] to [CLK 8]) can be installed on the keyboard.

Sale entries will be possible only when one of the [CLK] keys is depressed (in "REG", "MGR", or "☐" mode). When the same [CLK] key is again depressed, the cashier will go in Cashier OFF status.

- NOTES:**
1. No receipts are issued on turning ON or OFF a Cashier Key. However, the cashier code (1 to 8) or cashier name is printed near the bottom of every receipt to be issued.
 2. When adopting this cashier-identifying method, it is recommended to select the program option to display cashier code instead of department code. (Ask your TOSHIBA TEC representative.)
 3. The multi-drawer feature can be adopted on this cashier-identifying method. In this case, Drawer 1 is assigned to cashiers 1 and 2, and Drawer 2 to cashiers 3 to 8.

Cashier Reports

By adopting the Cashier Identifying option, Daily Cashier Read and Reset Reports (for individual cashiers) and Periodical Cashier Read and Reset Reports (for all the cashiers together in one report) are available. For the report taking operations and print format, see Chapter 3 on page 4 in Manager's Guide.

12. Training

This chapter describes a training provided for new employed cashiers. After entering the training mode, a cashier may operate the same transaction entries as those in the **REG** mode. The data in the training mode is not processed, therefore not affect any actual sales data in business.

- Turn the Control Lock to the **SET** position using the **MA** key.
- In the operation patterns, ☐ indicates an input through a numeric key, and indicates a depression of a transaction key.

Operation for Training Mode Start

..... A training start receipt is issued.

Entries in Training Mode

When the cashier identifying option is selected, a sign ON or cashier Key ON is required before starting operations. Refer to **Chapter 11. Cashier Identifying Operation** on page 17.

A trainee can operate all transaction entries described in the next chapter.

- except:
- 1) The drawer will not open.
 - 2) The consecutive No. will not be incremented.
 - 3) Entried contents will not be printed on a validation slip.

When the cashier identifying option is selected, a sign OFF or cashier key OFF is required after completing operations. Refer to **Chapter 11. Cashier Identifying Operation** on page 17.

Operation for Training Mode End

9 9 ST A training end receipt is issued.

Training Start Receipt -----> Training End Receipt

```

TEC STORE
1343 PEACH DRIVE
PHONE: 87-6437

Open 8:00am to 7:00pm
Closed: every Wednesday

11-28-1997      #112300

* TRAINING *
  ON
0118 09:20TM
    
```

Receipt issued in Training Mode

```

TEC STORE
1343 PEACH DRIVE
PHONE: 87-6437

Open 8:00am to 7:00pm
Closed: every Wednesday

11-28-1997      #112300

* TRAINING *
R/A              10.00
R/A              2.50
CASH             12.50

* TRAINING *
JONES           0118 09:21TM
    
```

```

TEC STORE
1343 PEACH DRIVE
PHONE: 87-6437

Open 8:00am to 7:00pm
Closed: every Wednesday

11-28-1997      #112300

* TRAINING *
  OFF
0118 09:21TM
    
```

Training Mode Symbol

Entry Contents

13. Transaction Entries

This chapter describes individual key operations on transaction entries.

- Turn the Control Lock to the **REG** position using the **REG** key.
- In the operation patterns, □ indicates an input through a numeric key, and ◻ indicates a depression of a transaction key.

WARNING!
<i>When opening the cash drawer, be careful not to let the drawer hit any person.</i>

Displaying the Time

The current time is displayed in the “AMOUNT” area when the Control Lock is turned to **REG** from any other position. When the Control Lock position is changed or any entry operation starts, the displayed time disappears.

Time Display Format: 13 - 45
(Example: 1:45 p.m.)

Receipt-issue/Non-issue Selection

Receipts are issued or not issued according to the “R OFF” lamp illuminated/extinguished status on the Operator Display panel.

Control Lock may be in any position except **OFF**.

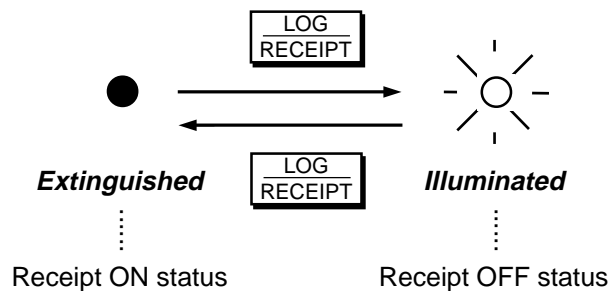

- NOTES:**
1. The Control Lock may be in any position (except OFF position) for changing the Receipt ON/OFF status.
 2. The “R OFF” lamp status at the starting of a transaction entry decides whether a receipt will be issued for the transaction or not. Switching the Receipt ON/OFF status during a transaction will not be effective.
 3. If a transaction is entered with the “R OFF” lamp illuminated and finalized but a receipt is required, the **[RECEIPT ISSUE]** key can be operated to issue a receipt. (Refer to “**Post-issue Receipt**” on page 40.)

Clearing Errors, or Clearing Wrong Declaration Key or Wrong Numeric Entries

When in sale entries an error has occurred with an alarm buzzer, a wrong declaration key has been depressed and/or a wrong numeric data has been entered;

Depress the key to cancel the error condition or the entered data.

For details for clearing the error, refer to **Chapter 16. Troubleshooting** on page 53.

No-sale (Exchange) <operable outside a sale only>

..... The drawer opens.
(or)

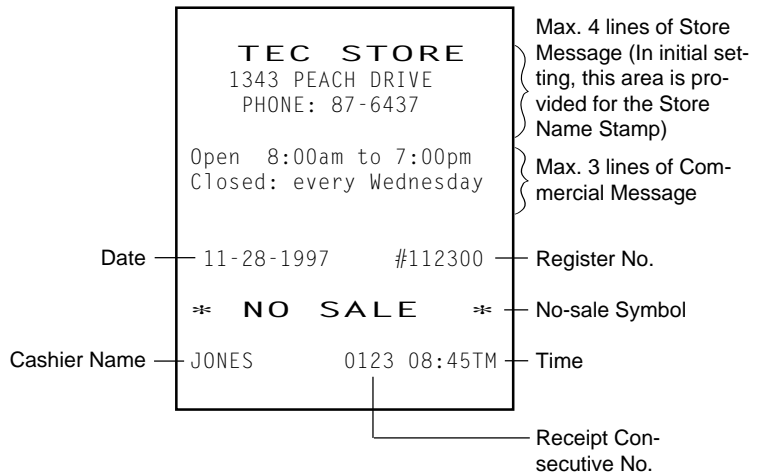

NOTE: Usually, Non-add Number entries are prohibited at the starting of a No-sale transaction (i.e. Non-add Numbers cannot be printed on a No-sale receipt). However, a No-sale entry can be programmed to be allowable after a Non-add Number entry (ask your TOSHIBA TEC representative).

Received-on-Account Payment <operable outside a sale only>

Repeat if multiple amounts are received.

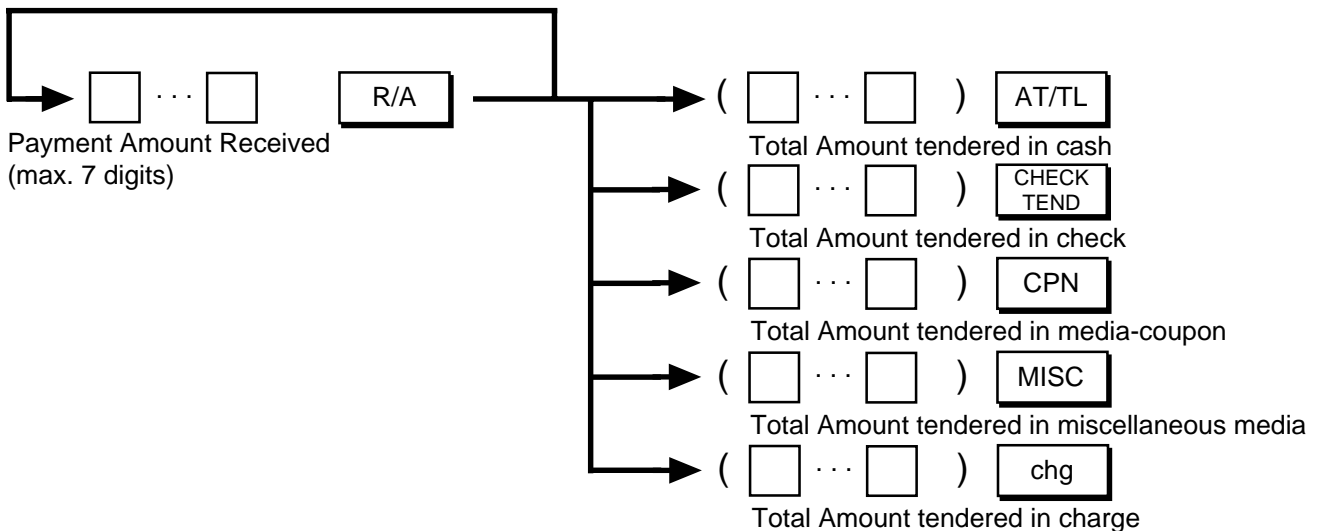

NOTE: As initial setting, all the media keys shown on the preceding page except the **[chg]** key can be used in the Received-on-Account transaction.

TEC STORE		
1343 PEACH DRIVE		
PHONE: 87-6437		
Open 8:00am to 7:00pm		
Closed: every Wednesday		
11-28-1997	#112300	
R/A	10.00	} Individual Amount (cash)
R/A	2.50	
CASH	12.50	} Total Amount received in cash
JONES	0127 09:12TM	

Paid Out
<operable outside a sale only>

Repeat if multiple amounts are paid out.

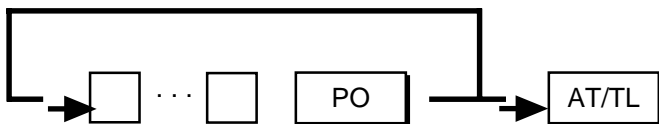

TEC STORE		
1343 PEACH DRIVE		
PHONE: 87-6437		
Open 8:00am to 7:00pm		
Closed: every Wednesday		
11-28-1997	#112300	
PO	3.00	} Individual Paid-out Amounts
PO	2.00	
PO	1.50	
TOTAL	6.50	} Total Amount Paid-out
JONES	0128 09:22TM	

- NOTES:**
1. For finalizing the transaction, only the **[AT/TL]** key can be used. (i.e. only cash can be paid out)
 2. Paid Out transaction can be programmed to require the **MGR** position of the Control Lock. If so programmed, an error will occur on depressing the **[PO]** key in the **REG** position. In this case, ask the store manager to turn the Control Lock to the **MGR** position for the transaction. (Refer to the chapter 1. Operations in "MGR" Mode on page 1 in Manager's Guide.)

Department Entries

1) Entry of One Item:

Open-price Department

...

Price; Max. 7 digits

Preset-price Department

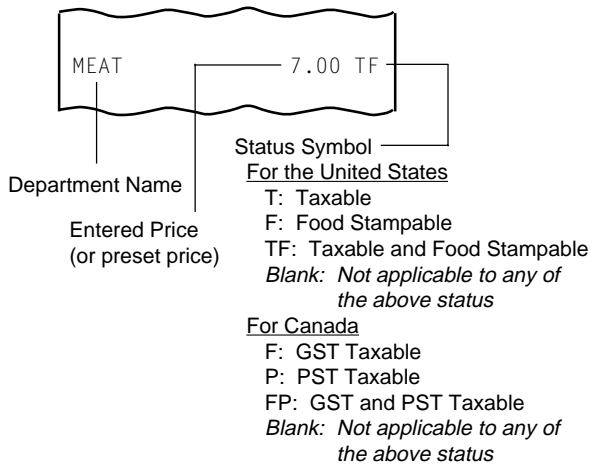

NOTE: Entry of a negative department can be programmed to require the **MGR** position of the Control Lock. If so programmed, an error will occur on entering the negative department in the **REG** position. In this case, ask the store manager to turn the Control Lock to the **MGR** position for the entry. (Refer to the chapter 1. **Operations in "MGR" Mode** on page 1 in *Manager's Guide*.)

2) Repeat Entry

Open-price Department

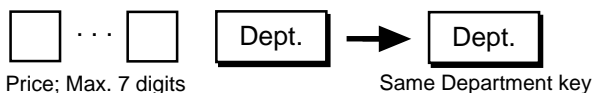

MEAT	7.00	TF
MEAT	7.00	TF

Preset-price Department

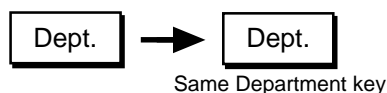

NOTE: A negative department cannot be repeated.

3) Quantity Extension (Multiplication)

Open-price Department

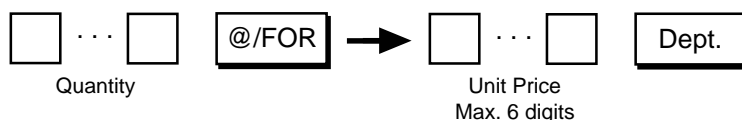

Preset-price Department



Quantity	12X	0.50	@	Unit Price
	FISH			Product
			6.00	TF

Department Name

- NOTES:**
- Quantity... Max. 6 digits (Max. 3 digits for integer + max. 3 digits for decimal. Use the [.] key if a decimal portion is contained.)
Unit Price ... Max. 6 digits
Product (result of multiplication) ... Must not exceed 7 digits.
 - When the Quantity is 1-digit integer (1 to 9) and a Preset-price Department key follows, the [**@/FOR**] key is omissible.
 - The decimal portion of the Quantity entry is processed down to the 2 digits below the decimal point. The fraction rounding at this time is fixed to **ROUND OFF**.
 - You can select the rounding process of the fractions of the product —**ROUND OFF** (initial setting), **ROUND UP**, or **ROUND DOWN**. (Ask your **TOSHIBA TEC** representative.)

4) Department SPP (Split-Package-Pricing)

This operation is used when a customer purchases only part but not all of the items in a package (example: only two tomatoes in a priced package of three tomatoes.)

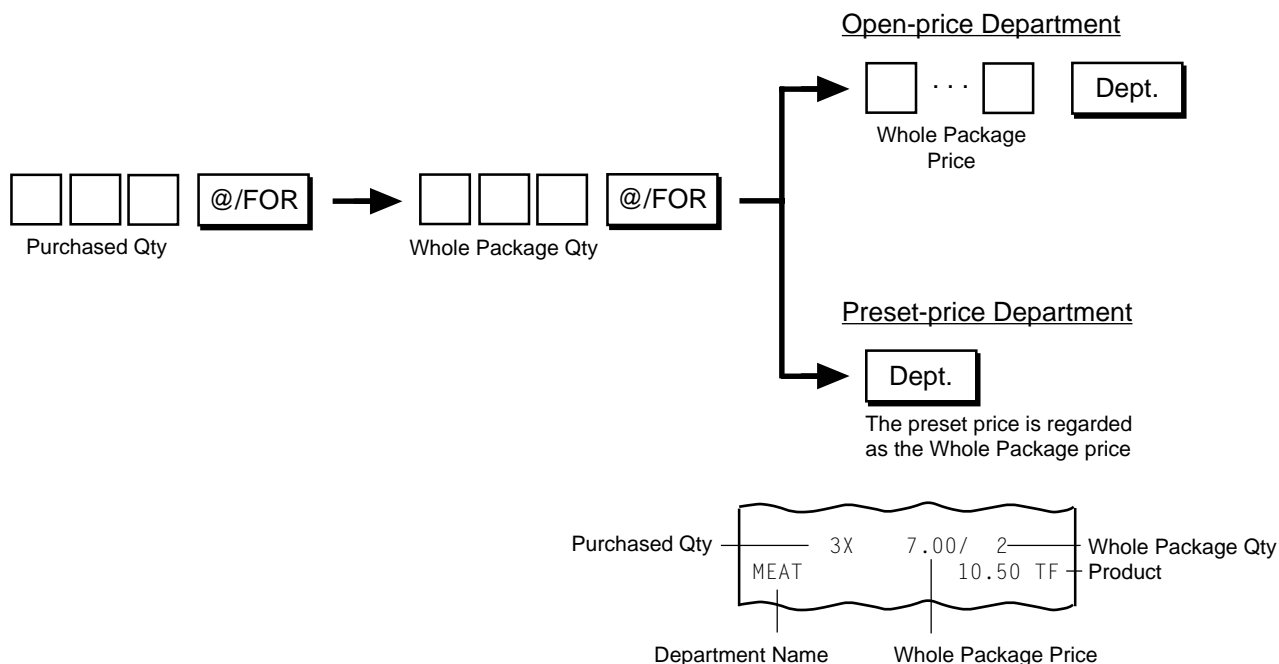

- NOTES:**
1. Purchased Qty ... Max. 3 digits (integer only)
Whole Package Qty ... Max. 3 digits (integer only)
Whole Package Price ... Max. 6 digits
Product (result of SPP) ... Must not exceed 7 digits.
 2. You can select the rounding process of the fractions of the product - ROUND UP PRODUCT (initial setting), or ROUND UP ITEM PRICE. (Ask your TOSHIBA TEC representative.)

5) Single-item Department Entry

If a Department key is programmed with single-item status, an entry through the key immediately finalizes the sale as cash without operating a Media key. The operation is the same as ordinary itemized Department keys already described (Entry of One Item, Quantity Extension, Department SPP).

NOTE: A sale item entry through this key will automatically finalize the sale as cash outside a sale (i. e. when no other items have been entered within one receipt sequence). However, it will function just as an Itemized Key if operated inside a sale.

```

TEC STORE
1343 PEACH DRIVE
PHONE: 87-6437

Open 8:00am to 7:00pm
Closed: every Wednesday

11-28-1997      #112300

DP05           2.00-
CASH           2.00-

JONES          0138 10:07TM
    
```

6) Other Income Department Entry

Department key with other income status programmed is used to enter items which do not directly become sales for the store, such as lottery, postage, gift wrapping fee, size adjustment fee, utility (payment of electric and gas), and donation. The operation is the same as ordinary Department keys already described.

PLU Entries

1) Entry of One Item:

Preset-price PLU

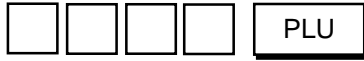

PLU Code; Max.
4 digits 1 to 9999

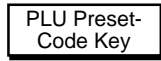

Open-price PLU



PLU Code; Max.
4 digits 1 to 9999

Unit Price; Max. 7 digits



Unit Price;
Max. 7 digits

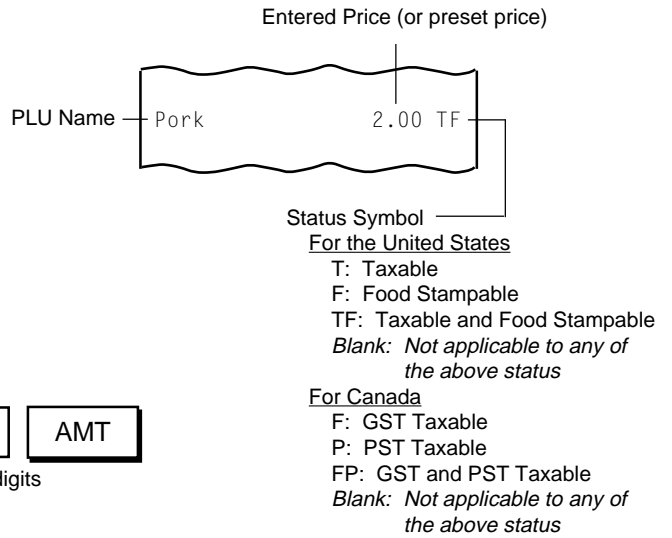

NOTE: [PLU Preset-code Key] can be provided on the ECR keyboard and/or the PK-2 keyboard (hardware option; PLU Keyboard).

2) Repeat Entry

Preset-price PLU



PLU Code; Max.
4 digits 1 to 9999

To repeat

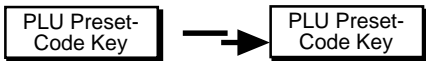

To repeat



Open-price PLU

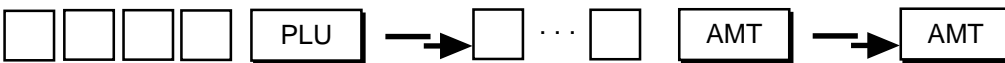

PLU Code

Unit Price

To repeat



Unit Price

To repeat

NOTE: A negative PLU entry cannot be repeated.

3) Quantity Extension (Multiplication)

Preset-price PLU

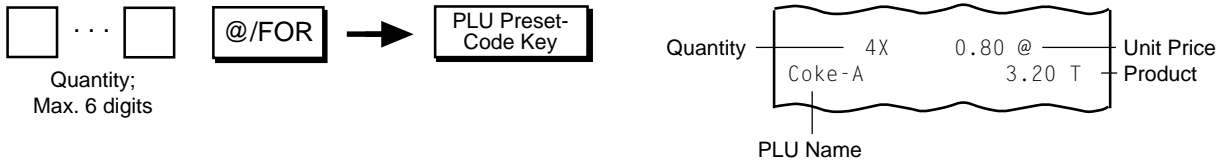
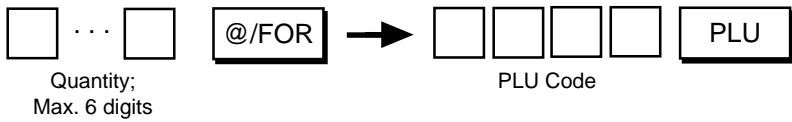

Open-price PLU

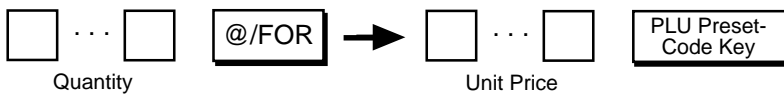

- NOTES:**
- Quantity... Max. 6 digits (Max. 3 digits for integer + max. 3 digits for decimal. Use the [.] key if a decimal portion is contained.)
Unit Price ... Max. 6 digits
Product (result of multiplication) ... Must not exceed 7 digits.
 - The decimal portion of the Quantity entry is processed down to the 2 digits below the decimal point. The fraction rounding at this time is fixed to ROUND OFF.
 - You can select the rounding process of the fractions of the product —ROUND OFF (initial setting), ROUND UP, or ROUND DOWN. (Ask your TOSHIBA TEC representative.)

4) PLU SPP (Split-Package-Pricing)

This operation is used when a customer purchases only part but not all of the items in a package (example; only two tomatoes in a priced package of three tomatoes.) (Also, refer to “**Department SPP**” on page 25 already described.)

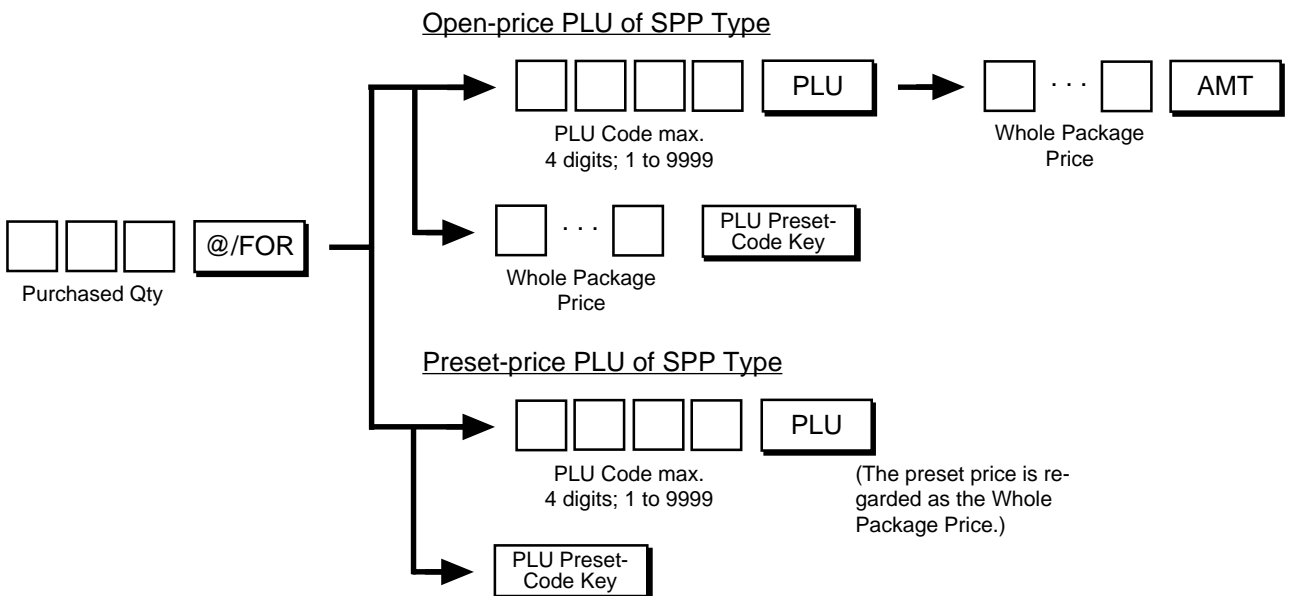

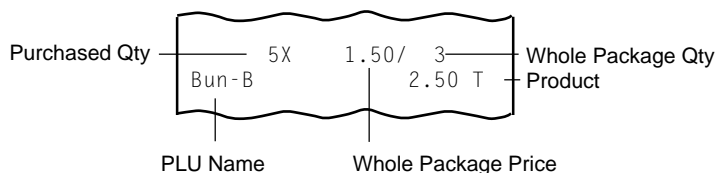

- NOTES:**
1. *Purchased Qty ... Max. 3 digits (integer only)*
Whole Package Price ... Max. 6 digits
Product (result of SPP) ... Must not exceed 7 digits.
You can select the rounding process of the fractions of the product - ROUND UP PRODUCT (initial setting), or ROUND UP ITEM PRICE. (Ask your TOSHIBA TEC representative.)
 2. *PLU SPP is possible only using the PLUs of SPP Type (i.e. programmed with Whole Package Quantity).*

5) Single-item PLU Entry

If a Department key is programmed with Single-item Status, an entry through a PLU which links to the Department immediately finalizes the sale as cash without operating a Media key. The operation is the same as ordinary Itemized PLU entries already described (Entry of One Item, Quantity Extension, PLU SPP).

```

TEC STORE
1343 PEACH DRIVE
PHONE: 87-6437

Open 8:00am to 7:00pm
Closed: every Wednesday

11-28-1997      #112300

PLU500          0.50-
CASH            0.50-

JONES          0142 10:45TM
    
```

PLU Price Shift Entry

Depressing the **[PRICE SHIFT]** key designates a PLU item, adding the printed number (1 to 3) to an entered PLU code.

- PRICE SHIFT 1** → PLU Entry (To enter a PLU item of the entered code plus 1)
- PRICE SHIFT 2** → PLU Entry (To enter a PLU item of the entered code plus 2)
- PRICE SHIFT 3** → PLU Entry (To enter a PLU item of the entered code plus 3)

Example) When the PLU Code 200 is designated after the **[PRICE SHIFT 2]** is depressed, this sales transaction will result in the sales item entry of the PLU Code 202.

- NOTES:**
1. *Depressing the [C] key immediately after the [PRICE SHIFT] key results in the cancellation of the PLU Price Shift Entry.*
 2. *The [PRICE SHIFT] key can be depressed any number of times before the PLU Entry. The last depressed [PRICE SHIFT] key becomes effective.*
 3. *The current PLU Shift No. declared by each [PRICE SHIFT] key can be displayed instead of Department Code by the program option.*

Preset Price Open

When an open price must be entered through a Preset-price Department, use the **[PR OPEN]** (or **[OPEN]**) key to release the preset-price status temporarily.

Depress **[PR OPEN]** (or **[OPEN]**) prior to or any time during the entry sequence of the following operations:

Entry of One Department Item
Department Quantity Extension
Department SPP
Other Income Department Entry
Single-item Department Entry

- NOTES:**
1. A price entry by Preset Price Open cannot be repeated.
 2. The Preset Price Open entry is not possible for any PLUs.

Listing Capacity Open

When an item entry price exceeds the Listing Capacity (programmed for each department) in sale entries, use the **[LC OPEN]** (or **[OPEN]**) key to release the Listing Capacity. The Listing Capacity for the department or PLU will be exceeded with two higher digits for that entry only. (If a price of further high digits must be entered, call for Manager Intervention. Refer to the chapter 1. **Operations in "MGR" Mode** on page 1 in Manager's Guide.)

Depress **[LC OPEN]** (or **[OPEN]**) prior to or any time (before the final key at the latest) during the entry sequence of the following operations:

Entry of One Department Item
Department Repeat Entry (NOTE)
Department Quantity Extension
Department SPP
Single-item Department Entry
Other Income Department Entry
Entry of One PLU Item
PLU Repeat Entry (NOTE)
PLU Quantity Extension
PLU SPP
Single-item PLU Entry

- NOTE:** When the **[OPEN]** key is used instead of **[LC OPEN]**, a repeat entry is not possible (because the **[PR OPEN]** key function also becomes effective).

Percent Discount, Percent Charge

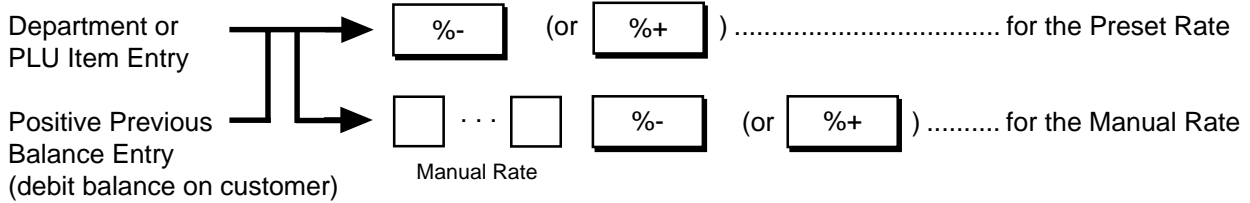

DRINK	6.00	T	} Dep 3 (DRINK) \$6.00 5% on \$6.00 = \$0.30 is discounted.
%- 5%	0.30	-	

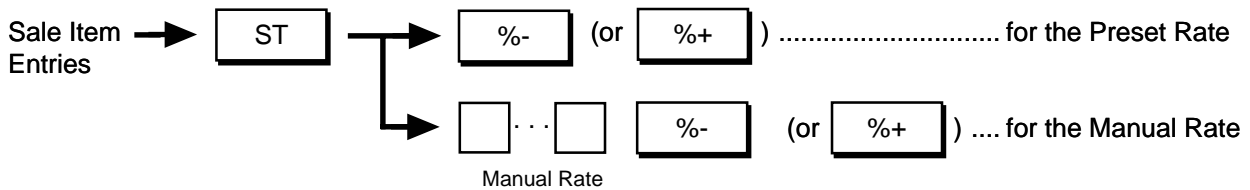

SUBTL	15.00		} Subtotal \$15.00 obtained 10% on \$15.00 = \$1.50 is added.
%+ 10%	1.50		

- NOTES:**
1. Manual Rate... Max. 5 digits (Max. 2 digits for integer + max. 3 digits for decimal. Use the [.] key if a decimal portion is contained.)
 2. When a rate is manually entered through a % key preset with a rate, the manual rate prevails.
 3. A % entry will cause an error if operated after a Negative Department entry or an Other Income Department entry.
 4. A % entry after obtaining a Subtotal is usually allowed only once. However, it can be programmed to allow multiple times. (Ask your TOSHIBA TEC representative.)
 5. You can select the rounding process of the fractions of the product (result of % calculation) — ROUND OFF (initial setting), ROUND UP, or ROUND DOWN. (Ask your TOSHIBA TEC representative.)
 6. Each of the % keys has its own Tax (PST) Status, GST Status, and Food Stamp Status programmed. Refer to “**Tax Status Modification**” (page 40) and “**Food Stamp Modification**” (page 41) for reversing the status.
 7. Percent Discount can be programmed to require the **MGR** position of the Control Lock. If so programmed, an error will occur on depressing the [%-] key in the **REG** position. In this case, ask the store manager to turn the Control Lock to the **MGR** position for the entry. (Refer to the chapter 1. **Operations in “MGR” Mode** on page 1 in Manager's Guide.)

Dollar Discount

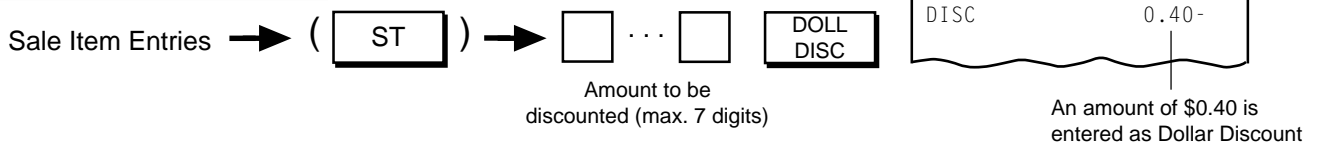

- NOTES:**
- For entering a Dollar Discount that will cause the sale total into negative (credit balance), one of the following can be selected (ask your TOSHIBA TEC representative):
If status "Credit Balance Prohibited" (initial status) is selected:
Over-subtraction of the sale total by Dollar Discount causes an error.
If status "Credit Balance Allowed" is selected:
Over-subtraction of the sale total by Dollar Discount is possible.
 - The **[DOLL DISC]** key has its own Tax (PST) Status, GST Status, and Food Stamp Status programmed. Refer to "Tax Status Modification" (page 40) and "Food Stamp Modification" (page 41) for reversing the status.
 - Dollar Discount can be programmed to require the **MGR** position of the Control Lock. If so programmed, an error will occur on depressing the **[DOLL DISC]** key in the **REG** position. In this case, ask the store manager to turn the Control Lock to the **MGR** position for the entry. (Refer to the chapter 1. Operations in "MGR" Mode on page 1 in Manager's Guide.)

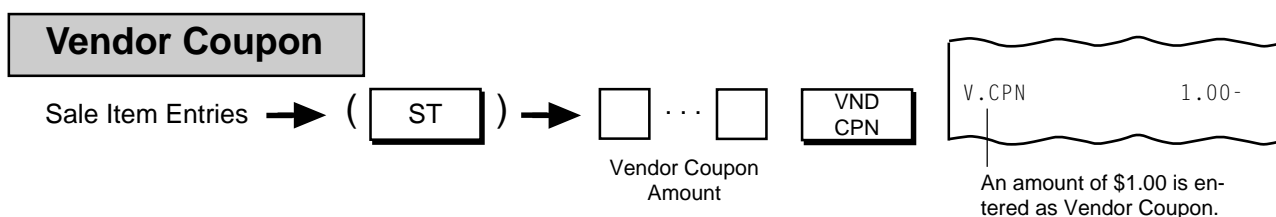

- NOTES:**
- For entering a Vendor Coupon amount that will cause the sale total into negative (Credit Balance), one of the following can be selected (ask your TOSHIBA TEC representative):
If status "Credit Balance Prohibited" (initial status) is selected:
Over-subtraction of the sale total by Vendor Coupon causes an error.
If status "Credit Balance Allowed" is selected:
Over-subtraction of the sale total by Vendor Coupon is possible.
 - The **[VND CPN]** key has its own Tax (PST) Status, GST Status, and Food Stamp Status programmed. Refer to "Tax Status Modification" (page 40) and "Food Stamp Modification" (page 41) for reversing the status.
 - Vendor Coupon Entry can be programmed to require the **MGR** position of the Control Lock. If so programmed, an error will occur on depressing the **[VND CPN]** key in the **REG** position. In this case, ask the store manager to turn the Control Lock to the **MGR** position for the entry. (Refer to the chapter 1. Operations in "MGR" Mode on page 1 in Manager's Guide.)
 - When a limit amount has been programmed for the **[VND CPN]** key, an amount exceeding the limit amount cannot be entered in the **REG** position. However, in the **MGR** or position, the limit amount programmed is ignored and max. 7-digit amount can be entered through the **[VND CPN]** key.

Store Coupon

Depress STR
CPN prior to or any time during the entry sequence of the following operations for Open-price or Preset-price Departments already described:

Entry of One Department Item
Department Quantity Extension NOTE 3
Single-item Department Entry NOTE 2

- NOTES:**
- The **[STR CPN]** key must be pressed, at the latest, before the final key of the required Department entry sequence.
 - The Store Coupon amount must be entered inside a sale and must not exceed the sale total unless the "Credit Balance Allowed" option is selected. (Ask your TOSHIBA TEC representative.)
 - Quantity Extension (multiplication) is permitted with this key, but no decimal quantity will be accepted.

4. None of PLUs, Negative Departments, Other Income Departments, Void, Returned Merchandise entries are possible along with the **[STR CPN]** key within one item.
5. The Store Coupon amount will subtract the Department Amount but will not affect the Department Item Count in the report memory.
6. The **[STR CPN]** key has its own Tax (PST) Status, GST Status, and Food Stamp Status programmed. Refer to “**Tax Status Modification**” (page 40) and “**Food Stamp Modification**” (page 41) for reversing the status.
7. Store Coupon Entry can be programmed to require the **MGR** position of the Control Lock. If so programmed, an error will occur on depressing the **[STR CPN]** key in the **REG** position. In this case, ask the store manager to turn the Control Lock to the **MGR** position for the entry. (Refer to the chapter 1. **Operations in “MGR” Mode** on page 1 in Manager’s Guide.)



Item Correct (Last Line Voiding)

- Department Entries**
(except for Single Item Department Entry)
- PLU Entries**
(except for Single Item PLU Entry)
- Percent Discount or Percent Charge**
- Dollar Discount**
- Received-on-Account Item**
- Paid Out Item**
- Vendor Coupon**
- Store Coupon**
- Previous Balance**
- Manual Tax**

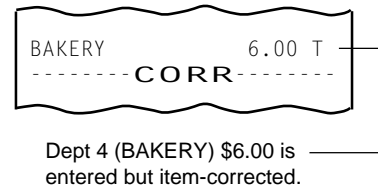
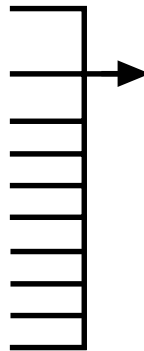

- NOTES:**
1. When the **[ITEM CORR]** key is depressed after repeated items, only the last item of the repeated is deleted, decrementing the “RPT” count in the display.
 2. When the **[ITEM CORR]** key is depressed after a Quantity Extension or Split Package Pricing, the entire product (result of the calculation) is deleted.

Void (Designated Line Voiding)

Depress **VOID** prior to or any time during the entry sequence of the following operations:

- Department Entries** (except for Repeat Entry)
- PLU Entries** (except for Repeat Entry)
- Percent Discount/Charge on a Department or PLU Item** (**NOTE 1**)

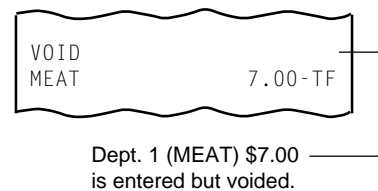

- NOTES:**
1. When an item previously entered with a Percent Discount or Percent Charge is canceled, the item can be voided with the Percent Discount/Charge by attaching the **[VOID]** key to the same entry procedure as previous entry.

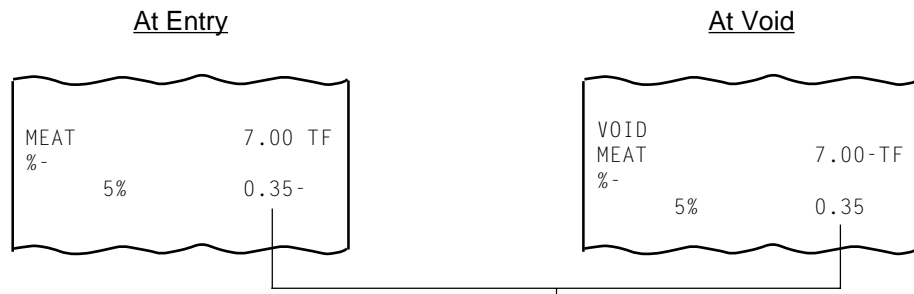

The process of the amount resulted from % calculation is reversed at Void.

2. The Void entries are usually possible only inside a sale. However, when the option "Credit Balance Allowed" is selected, they are allowed outside a sale as well and over-subtraction of the sale is also allowed. (Ask your TOSHIBA TEC representative.)
3. Neither Negative Department nor Negative PLU items can be entered as Void items.

All Void (Transaction Cancel)

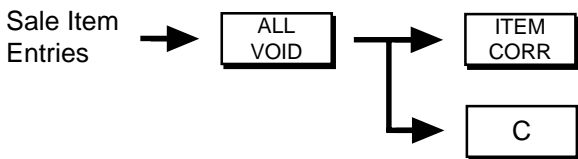

..... Executes the transaction cancel.

..... Clears the transaction cancel (continue the sale).

- NOTES:**
1. The All Void Operation is no longer acceptable when any media key (such as **[AT/TL]**) is entered including short-tendering.
 2. If Tax Exempt (using the **[EX]** key) is entered, the sale can no longer be all-voided.
 3. The All Void function is not effective for Received-on-Account or Paid Out transactions.
 4. When more than 20 items have been entered in the current sale, the All Void function is no longer effective.
 5. All Void Transaction can be programmed to require the **MGR** position of the Control Lock. If so programmed, an error will occur on depressing the **[ALL VOID]** key in the **REG** position. In this case, ask the store manager to turn the Control Lock to the **MGR** position for the transaction. (Refer to the chapter 1. **Operations in "MGR" Mode** on page 1 in Manager's Guide.)

TEC STORE	
1343 PEACH DRIVE PHONE: 87-6437	
Open 8:00am to 7:00pm Closed: every Wednesday	
11-28-1997	#112300
FISH	4.50 TF
14X	0.80 @
Coke-A	11.20 T
Beef	3.00 TF
SUBTL	18.70
* ALL VD * JONES 0154 15:19TM	

Items already entered in this sale.

Prints the subtotal when Transaction Cancel is executed.

All Void (Transaction Cancel) Symbol Line

Returned Merchandise

Depress RTN
MDSE prior to or any time (before the final key at the latest) during the entry sequence of the following operations:



Dept. 1 (MEAT) \$7.00 is entered but returned.

Department Entries
PLU Entries
Percent Discount/Charge on a Department or PLU Item (NOTE 1)

NOTES: 1. When an item once purchased with a Percent Discount or Percent Charge is returned, the item can be returned with the Percent Discount/Charge by attaching the **[RTN MDSE]** key to the same entry procedure as purchase.

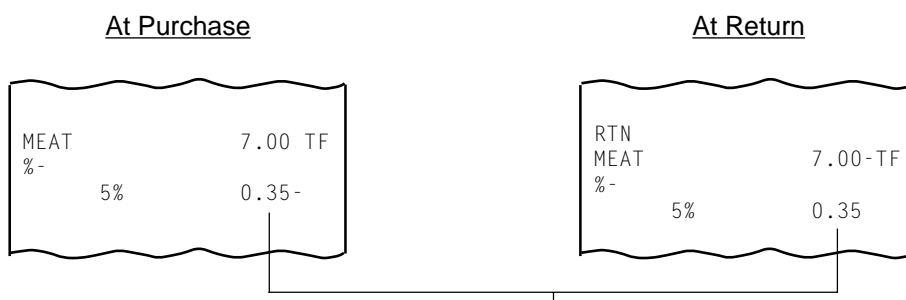

The process of the amount resulted from % calculation is reversed at Return.

2. The Returned Merchandise entries are possible outside as well as inside a sale. Over-subtraction of the sale is allowed for Returned Merchandise entries.
3. Neither Negative Department nor Negative PLU items can be entered as Returned Merchandise.
4. Returned Merchandise transaction can be programmed to require the **MGR** position of the Control Lock. If so programmed, an error will occur on depressing the **[RTN MDSE]** key in the **REG** position. In this case, ask the store manager to turn the Control Lock to the **MGR** position for the transaction. (Refer to the chapter 1. Operations in "MGR" Mode on page 1 in Manager's Guide.)

Non-add Number Print

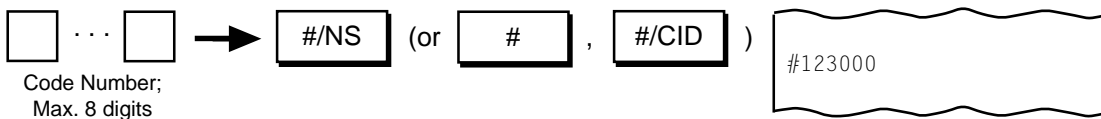

- Code Number;
Max. 8 digits
- NOTES:**
1. The preceding zeros, if any, will not be printed. For example, if "0123000" is entered, "123000" is printed.
 2. Usually, Non-add Number entries are prohibited at the starting of a No-sale transaction (i.e. Non-add Numbers cannot be printed on a No-sale receipt). However, a No-sale entry can be programmed to be allowable after a Non-add Number entry (ask your TOSHIBA TEC representative).
 3. Usually, Non-add Number entry is allowed multiple times in one sale. However, it can be programmed to be allowed only once (ask your TOSHIBA TEC representative).

Subtotal Read

Sale Item
Entries

ST

SUBTL	22.91	Subtotal Amount
-------	-------	-----------------

- NOTES:**
1. When the **[ST]** key is depressed, the sale total is displayed and printed. However, you can select not to print (display only) by a system option. (Ask your TOSHIBA TEC representative.) Even if this non-print option is selected, the subtotal amount is automatically printed when a Percent Charge/Discount or Dollar Discount entry follows a subtotal entry.
 2. Usually, both displayed subtotal and printed subtotal include no taxes due (Tax (PST)/GST exclusive). However, the subtotal amount including taxes due can be displayed by the program option. (Ask your TOSHIBA TEC representative.)
 3. If the program option "Taxable Total Compulsory" is selected with the function of subtotal display including taxes due (refer to NOTE 2 above), the **[ST]** key must always be depressed before operating the media keys for finalizing a sale. (Ask your TOSHIBA TEC representative.)
 4. When the **[ST]** key is depressed more than once consecutively, the subtotal amount is only displayed but no print occurs from the second time on. If the **[C]** key is depressed to clear a numeric entry or error, etc. after a subtotal is once obtained, the subtotal amount will be again displayed.
 5. When the **[ST]** key is depressed during the Previous Balance Entry, the subtotal excluding the previous balance amount will be displayed.

Taxable Total Read

Sale Item
Entries

TXBL
TL

- NOTES:**
1. Displayed sale total amount includes taxes due (Tax(PST)/GST). No print occurs.
 2. If the program option "Taxable Total Compulsory" is selected, the **[TXBL TL]** key must always be depressed before operating the media keys for finalizing a sale. (Ask your TOSHIBA TEC representative.)
 3. If the **[C]** key is depressed to clear a numeric entry or error, etc. after a taxable total is once obtained, the taxable total amount will be again displayed.
 4. When the **[TXBL TL]** key is depressed during the Previous Balance Entry, the taxable total excluding the previous balance amount will be displayed.

Finalizing a Sale

1) Media Total

Sale Item
Entries

ST

TXBL
TL

AT/TL

TAX	0.36	Tax Amount
CASH	3.96	Cash Total
JONES 0159 15:40TM		

(or **CHECK TEND**, **chg**, **CPN**, **MISC**)

2) Media Tender

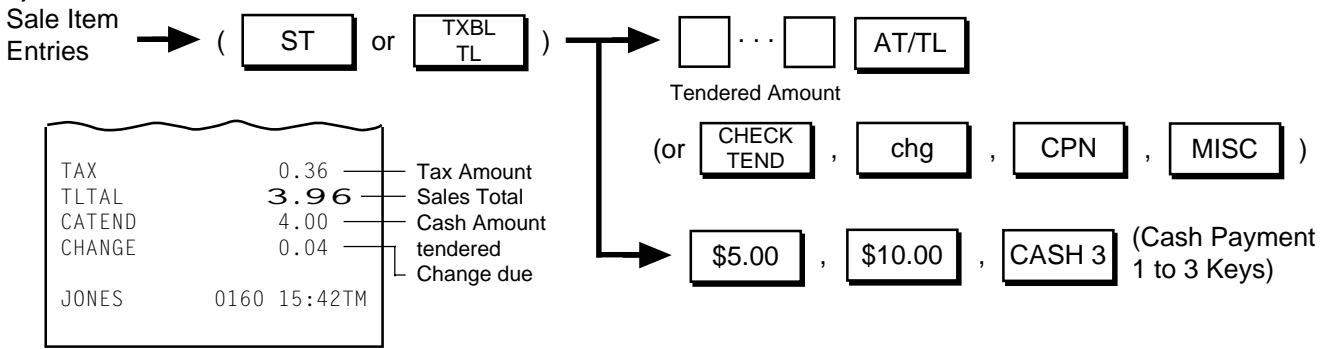

3) Multi-Tender (short-tender repeated by the same media)

Example)

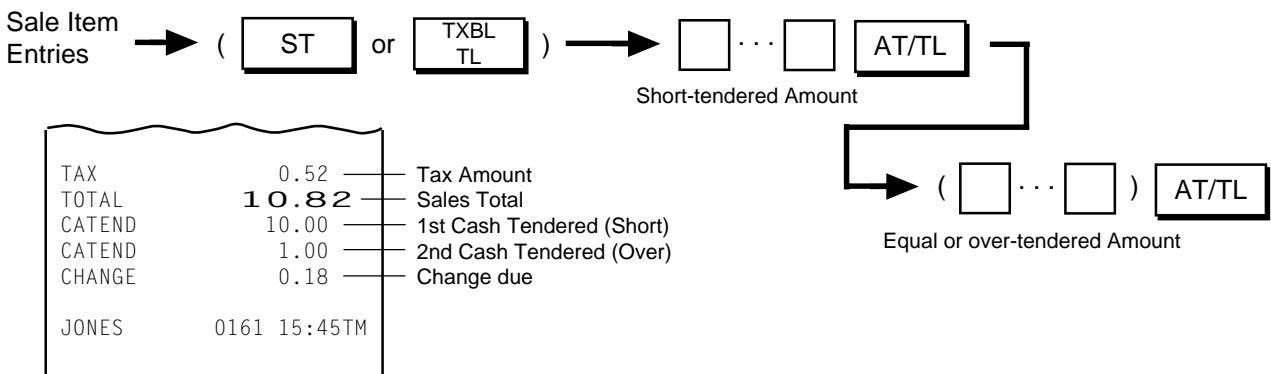

4) Split-Tender (short-tender repeated by the different media)

Example)

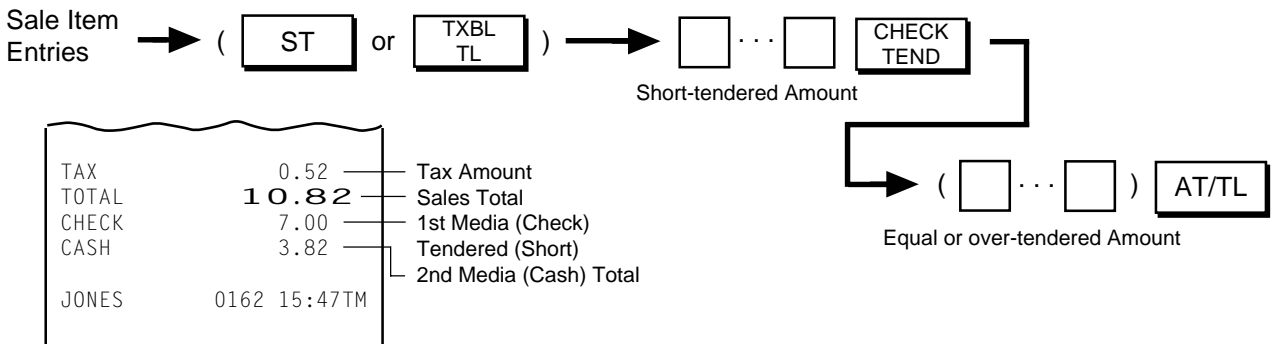

NOTES:

1. Functions of each media key are initially programmed as follows.
[AT/TL] ... Tender/Total, [CHECK TEND] ... Tender only, [chg] ... Total only, [MISC] ... Tender only, [CPN] ... Tender only
2. When the program option "Taxable Total Compulsory" (ask your TOSHIBA TEC representative) is selected, the sale is finalized after reading the sale total by the [ST] (or [TXBL TL]) key.
3. When the program option "Shot-tendering Prohibited" (ask your TOSHIBA TEC representative) is selected, short-tendering using the media keys including the Cash Payment key is impossible.
4. When a certain amount is not programmed to the Cash Payment key, use of its key for cash tendering operation will cause an error. Tendering amount \$ 5.00 is initially programmed for the [\$5.00] key, and \$10.00 for the [\$10.00] key.
5. The program option "Over-tendering Prohibited" can be selected individually for the media keys except the [AT/TL] key. Over-tendering operation using a media key to select this option becomes impossible.

6. When the HALC (High Amount Listing Capacity) is programmed to the respective tendering amounts of the media keys, tendering amount through the media key cannot exceed the programmed one in the **REG** position.

Food Stamp Tender

All the items are entered for the customer.

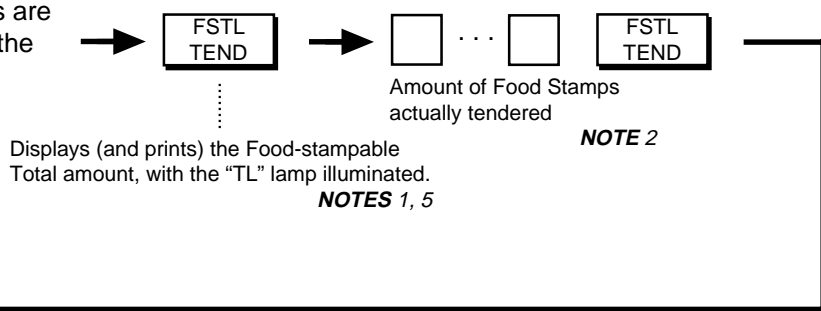

- When the sale is not finalized (i.e., short-tendered):
 → The balance due (shortage amount) is displayed. Operate other media total/tender operations.
NOTE 3
- When the sale is finalized (i.e., equal-or over-tendered):
 → The sale is finalized, a receipt is issued, and the change amount is displayed.
NOTE 4

- NOTES**
1. The displayed Food-stampable Total is the limit amount to be paid in food stamps. Accurately, however, the actual limit may become this displayed total + 99¢ due to the combination of changes due refunded in cash.
 2. The Amount of Food Stamps actually tendered may exceed the Food-stampable Total previously displayed. In that case, the exceeding amount (besides refunded as change in cash of max. 99¢) will be refunded in food stamps. Also refer to **NOTE 4**.
 3. Refer to **“Finalizing a Sale”** on the preceding pages.
 4. The “CG” lamp is illuminated. The change portion by the unit of \$1.00 will be returned in food stamps (1 to 99, indicating dollars, displayed in the “DPT” portion. The change portion less than \$1.00 will be returned in cash (displayed in the “AMOUNT” portion).
 5. The “Food-stampable Total” is the total of Department and PLU items that are programmed to be “Food-stampable” and are entered in the current sale. As for reversing the Food Stamp status of individual items at the moment of their entries, refer to **“Food Stamp Modification”** on page 41.
 6. When the HALC (High Amount Listing Capacity) is programmed to the tendering amount of the **[FSTL TEND]** key, tendering amount through its key cannot exceed the programmed one in the **REG** position.

Food Stamp Tender Print Format Samples

GENERAL Type		ILLINOIS Type																																																	
<table style="width: 100%; border-collapse: collapse;"> <tr><td>FISH</td><td style="text-align: right;">6.00</td><td>TF</td></tr> <tr><td>TAX</td><td style="text-align: right;">0.60</td><td></td></tr> <tr><td>TOTAL</td><td style="text-align: right;">6.60</td><td></td></tr> <tr><td>FS/TL</td><td style="text-align: right;">6.60</td><td></td></tr> <tr><td>F-STMP</td><td style="text-align: right;">10.00</td><td></td></tr> <tr><td>CHANGE</td><td style="text-align: right;">0.40</td><td></td></tr> <tr><td>FS CHG</td><td style="text-align: right;">3.00</td><td></td></tr> <tr><td colspan="3"> </td></tr> <tr><td>JONES</td><td style="text-align: right;">0164</td><td>16:31TM</td></tr> </table>	FISH	6.00	TF	TAX	0.60		TOTAL	6.60		FS/TL	6.60		F-STMP	10.00		CHANGE	0.40		FS CHG	3.00					JONES	0164	16:31TM	<p>The customer may pay up to the food-stampable amount plus its taxes due in food stamps.</p>	<table style="width: 100%; border-collapse: collapse;"> <tr><td>FISH</td><td style="text-align: right;">6.00</td><td>TF</td></tr> <tr><td>FS/TL</td><td style="text-align: right;">6.00</td><td></td></tr> <tr><td>F-STMP</td><td style="text-align: right;">5.00</td><td></td></tr> <tr><td>TAX</td><td style="text-align: right;">0.10</td><td></td></tr> <tr><td>CASH</td><td style="text-align: right;">1.10</td><td></td></tr> <tr><td colspan="3"> </td></tr> <tr><td>SMITH</td><td style="text-align: right;">0169</td><td>16:43TM</td></tr> </table>	FISH	6.00	TF	FS/TL	6.00		F-STMP	5.00		TAX	0.10		CASH	1.10					SMITH	0169	16:43TM	<p>The customer may pay up to the food-stampable amount in food stamps, and the amount actually paid in food stamps is tax-exempted.</p>
FISH	6.00	TF																																																	
TAX	0.60																																																		
TOTAL	6.60																																																		
FS/TL	6.60																																																		
F-STMP	10.00																																																		
CHANGE	0.40																																																		
FS CHG	3.00																																																		
JONES	0164	16:31TM																																																	
FISH	6.00	TF																																																	
FS/TL	6.00																																																		
F-STMP	5.00																																																		
TAX	0.10																																																		
CASH	1.10																																																		
SMITH	0169	16:43TM																																																	
<p>Food-stampable Item</p> <p>Food-stampable Total (including tax on Food-stampable Total)</p> <p>Food Stamp Tendered</p> <p>Change in Cash</p> <p>Change in Food Stamps</p>		<p>Food-stampable Item</p> <p>Food-stampable Total (excluding tax on Food-stampable Total)</p> <p>Food Stamp Tendered</p> <p>Cash Total</p>																																																	

NEW JERSEY Type

FISH	6.00	TF	Food-stampable Item
DRINK	2.00	T	
FS/TL	6.00		
F-STMP	6.00		Food-stampable Total
TAX	0.30		(including tax on Food-stampable Total)
CASH	2.30		Food Stamp Tendered
			Cash Total
JONES 0174 16:46TM			

The customer may pay up to the food-stampable amount in food stamps, and the food-stampable amount is tax-exempted regardless of the actual amount paid in food stamps.

Previous Balance, Charge Posting

(1) To initiate charge posting for a new customer

(or) → Follow the line marked with "*" in operation (2) below.

(2) Charge posting with a previous balance first entered (pre-select) with or without PAYMENT

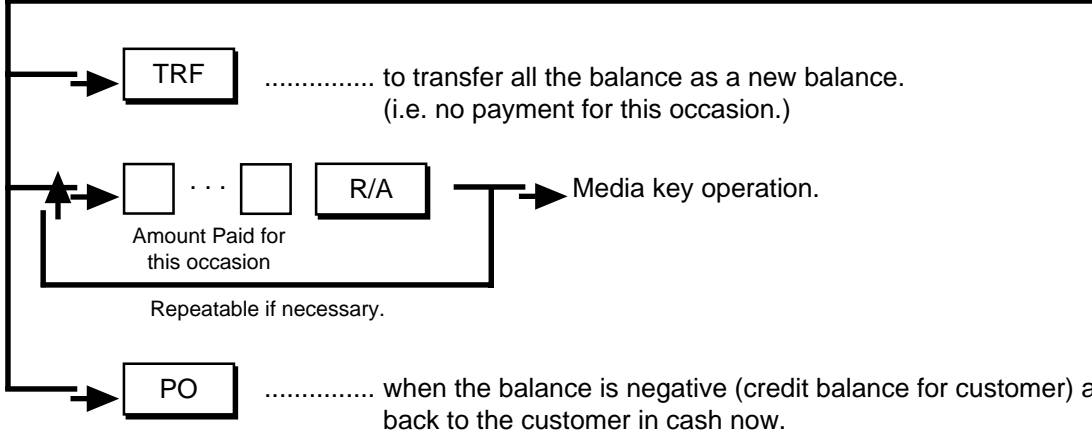
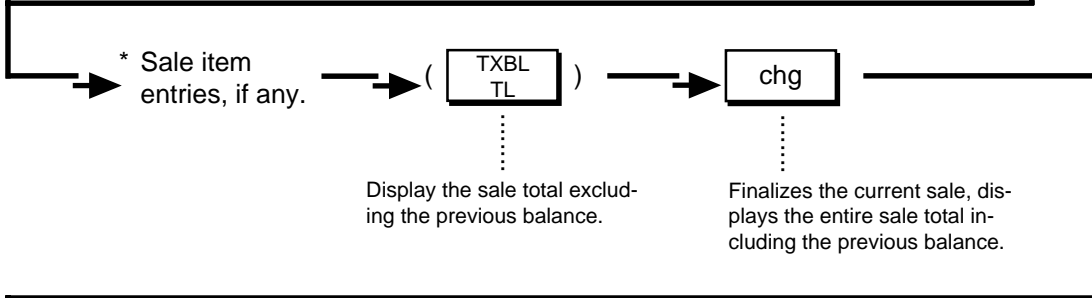
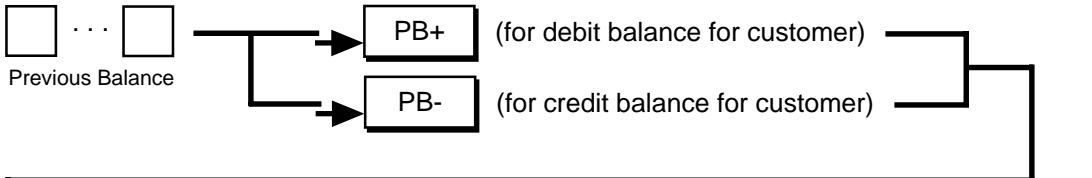

(3) Charge posting with a previous balance entered during a sale (post-select)

A previous balance may be entered not only before sale items but also after or between them if the [chg] key has not been depressed. Multiple previous balance entries are possible within a sale (for the purpose to sum up multiple accounts into one, etc.)

(4) Percent charge/discount on a previous balance

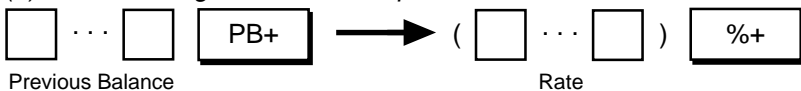

- NOTES:**
1. The [%-] key operates the same for percent discounting.
 2. The previous balance entered through [PB-] (credit balance for customer) will not allow %+ or %- operation.

```

TEC STORE
1343 PEACH DRIVE
PHONE: 87-6437

Open 8:00am to 7:00pm
Closed: every Wednesday

11-28-1997      #112300

PB+             0.00
MEAT            7.00 TF
    3X      1.00 @
Coke-B         3.00 T
SUBTL          10.00
TAX             0.80
Chg             10.80
R/A             5.00
CASH            5.00

NEW BAL        5.80

JONES          0179 17:05TM
    
```

A customer who has no previous balance comes to the store. He purchases sales items; Dept.1 (MEAT) and three items of PLU No. 301 (Coke-B). He pays \$5.00 in this time, and the remainder of the balance is carried forward to the next time.

```

TEC STORE
1343 PEACH DRIVE
PHONE: 87-6437

Open 8:00am to 7:00pm
Closed: every Wednesday

11-28-1997      #112300

PB+             5.80
Chg             5.80
R/A             5.80
CASH            5.80

NEW BAL        0.00

JONES          0180 17:08TM
    
```

The customer comes again to pay all the previous balance. He pays the exact amount in cash. The balance of the customer becomes zero.

Check Cashing (Cashing Non-cash Media)

<operable outside a sale only>

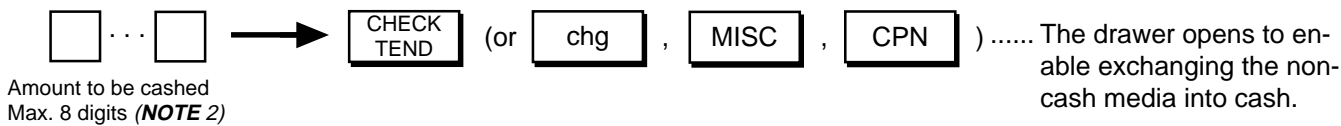

- NOTES:**
1. The [CHECK TEND] key is programmed to allow cashing as initial status. It can be programmed to prohibit cashing. Similarly, the [chg], [MISC] and [CPN] keys are programmed to prohibit cashing as initial status. They can be programmed to allow cashing. (Ask your TOSHIBA TEC representative.)
 2. When the HALC (High Amount Listing Capacity) is programmed to the respective tendering amounts of the media keys, tendering amount through the media key cannot exceed the programmed one in the REG position.

```

TEC STORE
1343 PEACH DRIVE
PHONE: 87-6437

Open 8:00am to 7:00pm
Closed: every Wednesday



11-28-1997      #112300

CHECK           10.00

JONES          0188 17:19TM
    
```

- When the program option "Validation Print Compulsory" is programmed to the respective media keys, the drawer will open after performing the validation print. (Ask your TOSHIBA TEC representative.)

Post-issue Receipt

A sale is finalized with the "R OFF" lamp illuminated.   The receipt for the last sale is issued.

- NOTES:**
- When a sale has contents of 30 print lines or less, the post-issue receipt will be an itemized receipt, just as the ordinary receipt. When it has more than 30 print lines, the post-issue receipt will be a total-only receipt. However, the program option allows the register to always issue a total-only receipt regardless of the number of the print lines. (Ask your TOSHIBA TEC representative.)
 - The Post-issue receipt function is not effective for Received-on-Account, Paid Out, Previous Balance, nor All Void transaction.
 - If a Non-add Number print is entered at the top of a sale, the number will not be printed on the Post-issue Receipt.
 - Usually, the Post-issue Receipt function is available only when a sale has been entered with the "R OFF" lamp illuminated. However, the program option allows the register to issue a Post-issue receipt regardless of the "R OFF" status (illuminated or extinguished). (Ask your TOSHIBA TEC representative.)

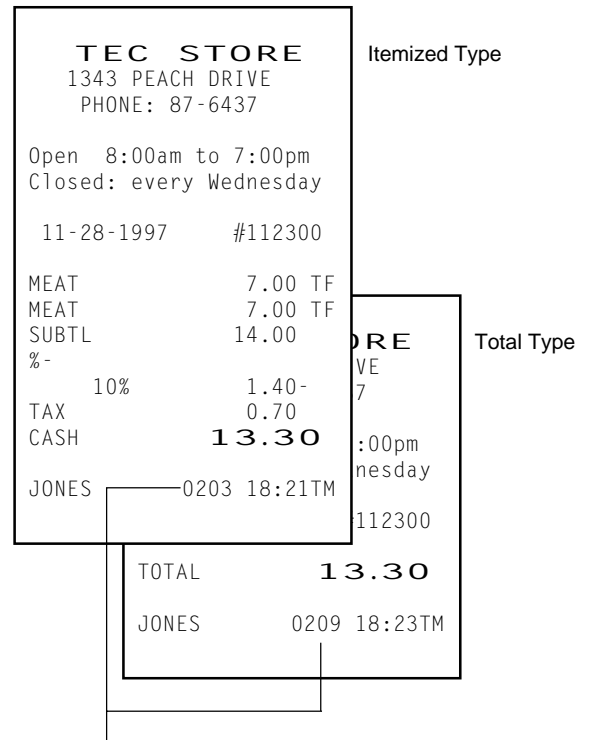

The Consecutive No. printed on the Post-issue Receipt is the same as that of the normal receipt if it has been issued.

Tax Status Modification

Tax status of the Department/PLU or required key is reversed:

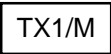
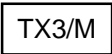
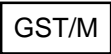
Depress  to ,  of which tax status is modified prior to or any time (before the final key at the latest) during the entry sequence of the following operations. More than one modifier keys can be depressed for the same item entry:

- Department Entries
- PLU Entries
- Percent Discount/Charge
- Dollar Discount
- Vendor Coupon
- Store Coupon

Food Stamp Modification

Food Stamp status of the Department/PLU or the required key is reversed.

Depress FS/M prior to or any time (before the final key at the latest) during the entry sequence of the following operations:

- Department Entries**
- PLU Entries**
- Percent Discount/Charge**
- Dollar Discount**
- Vendor Coupon**
- Store Coupon**

Tax Exemption

All the items are entered for the customer. → (ST or TXBL
TL)

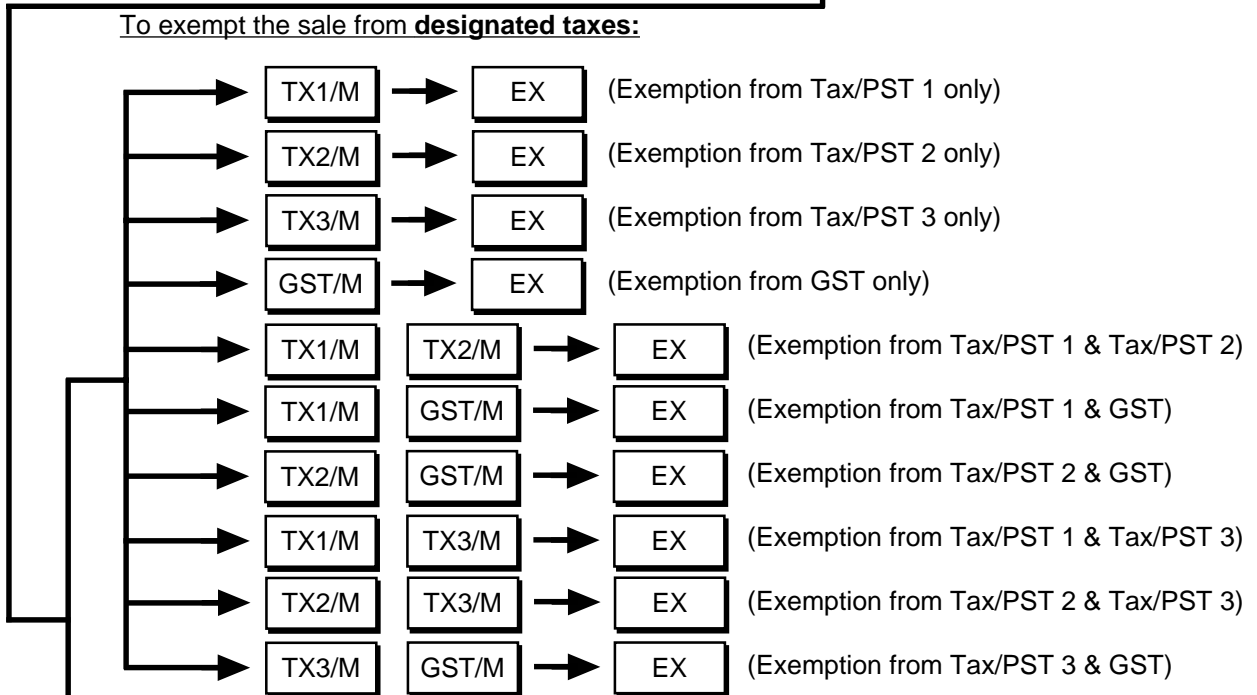

To exempt the sale from all taxes:

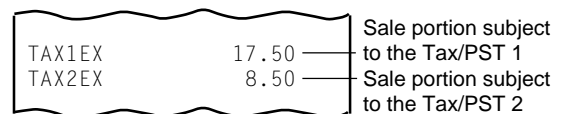
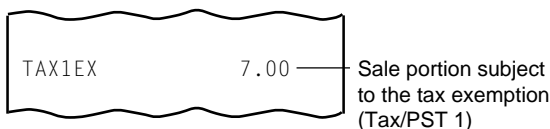
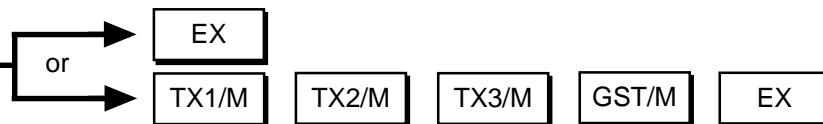

- NOTES:**
1. After depressing the **[EX]** key, the sale must only be finalized (for payment through media keys including the **[CUR]** keys).
 2. Tax Exemption transaction cannot be item-corrected.
 3. If the "Non-taxable Amount Limit" is set for certain areas in Canada, using the **[GST/M]** key will cause an error and GST Exemption is not allowed.

Manual Tax Entry

Sale Item Entries → ... **TAX** The entered tax amount is printed and added to the sale.
Tax Amount required

- NOTES:**
1. The **[TAX]** key should be used in the single tax area. It should not be used in the dual tax area nor the triple tax area.
 2. A Manual Tax amount entered can be item-corrected, but cannot be deleted by **[VOID]** nor **[RTN MDSE]** key.

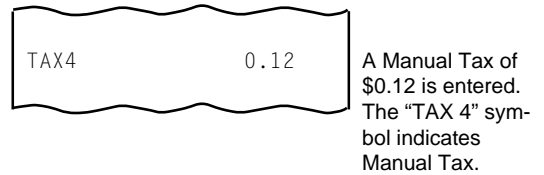

Sale paid in Foreign Currency

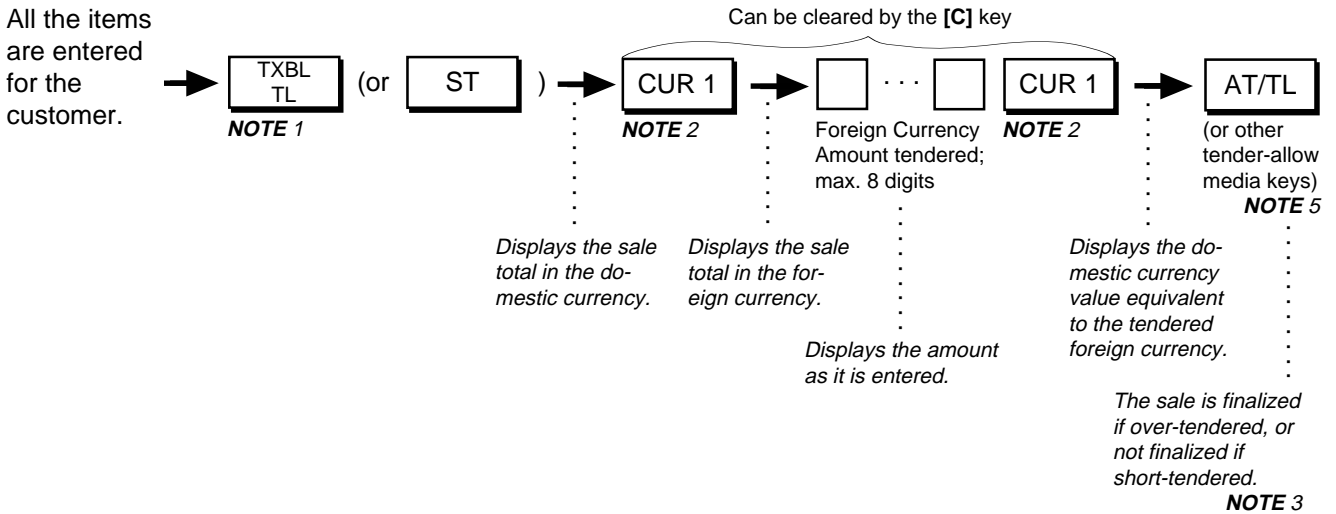

SUBTL	14.00	Sale total in domestic currency
TAX	1.22	
TOTAL	15.22	
CATEND	28.00	Domestic currency value equivalent to the tendered foreign currency
CHANGE	12.78	Change due in the domestic currency
JONES	0216 18:55TM	

The program option allows the register to print foreign currency tendered amount and foreign currency exchange rate on the receipt. (Ask your TOSHIBA TEC representative.)

- NOTES:**
1. The **[TXBL TL]** (or **[ST]**) key is not required after a short-tender entry. The **[ST]** key can be used for this transaction only when the program option "Taxable Total Display by the **[ST]** key" has been selected. (Ask your TOSHIBA TEC representative.)
 2. The **[CUR2]**, **[CUR3]** and **[CUR4]** keys operate the same fashion as the **[CUR1]** key for tendering the foreign currencies 2, 3 and 4 respectively.

3. When over-tendered:

The sale is finalized, the drawer opens, and the change due is displayed in the domestic currency which is to be returned to the customer.

When short-tendered:

The sale is not finalized. Any other media tendering may follow (refer to the section "**Multi-tender, Split Tender**" on page 36).

4. The tendered amount is processed into the following in the report memory:

- Domestic media (of the key operated — Cash, Check, Charge, Miscellaneous Media, Media-Coupon) total
- Foreign Currency in the foreign currency value.
- The amount is not processed into the corresponding media-in-drawer total.

5. The final media key must be programmed to allow tendering.

6. A negative-balance sale or a sale of zero cannot be finalized with a Foreign Currency key.

7. The Foreign Currency keys cannot be used to finalize Received-on-Account, Paid Out and Previous Balance entries.

No-sale Exchange from a Foreign Currency to the Domestic Currency

<operable outside a sale only>

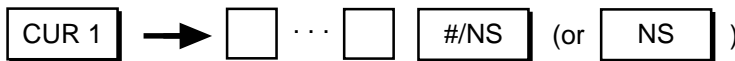

Amount of Foreign
Currency to be
exchanged

The drawer opens to enable exchange. Displays the domestic currency amount equivalent to the entered foreign currency amount.

NOTE: The [CUR2], [CUR3] and [CUR4] keys operate the same fashion as the [CUR1] key for exchanging the foreign currencies 2, 3 and 4 to the domestic currency.

CUR1	100.00
CHANGE	140.00
JONES	0222 13:39TM

Validation Print

A required sale item or media is entered. (**NOTE 3**)



Insert a slip to the Validation Slot. (See the sketch below.)

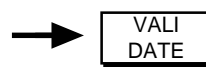

VALIDATE

- NOTES:**
1. On this register, depressing the [VALIDATE] key will execute printing regardless of presence/absence of a slip. Before depressing the key, be certain to insert a slip to the Validation Slot. (If no slip is inserted, the validation print will occur over the last printed line on the receipt.)
 2. After validation print, be certain to remove the slip from the Validation Slot.

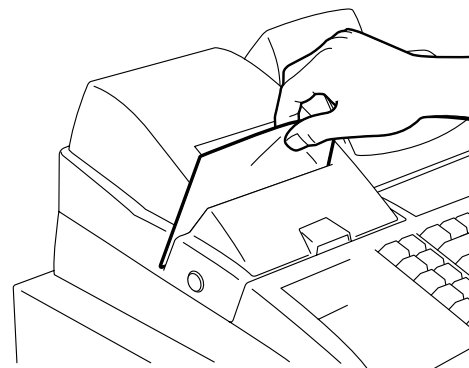

3. If the "SLIP" lamp flickers during registrations, it indicates that the last item just entered has been programmed to require validation print. In this case, no other operations can follow until the validation print of the item is performed.

4. The following options are selective in relation to validation print:

1) Print Format

a) Consecutive No. Print/Non-print

b) Cashier No. Print/Non-print

2) Number of times for validation print of the same item Single-validation (only once allowed), or Multi-validation (any number of times allowed)

3) Validation Print Content after each non-cash media tender

4) Validation Counter on the Financial Report Print/Non-print

5) Validation Compulsory status on the following keys:

[AT/TL], [CHECK TEND], [chg], [MISC], [CPN], [FS TL TEND], [TRF], [VND CPN], [STR CPN], [RTN MDSE], [PO], [R/A], [ITEM CORR], [VOID], [DOLL DISC], [%-], Negative Departments and PLUs.

For details, ask your TOSHIBA TEC representative.

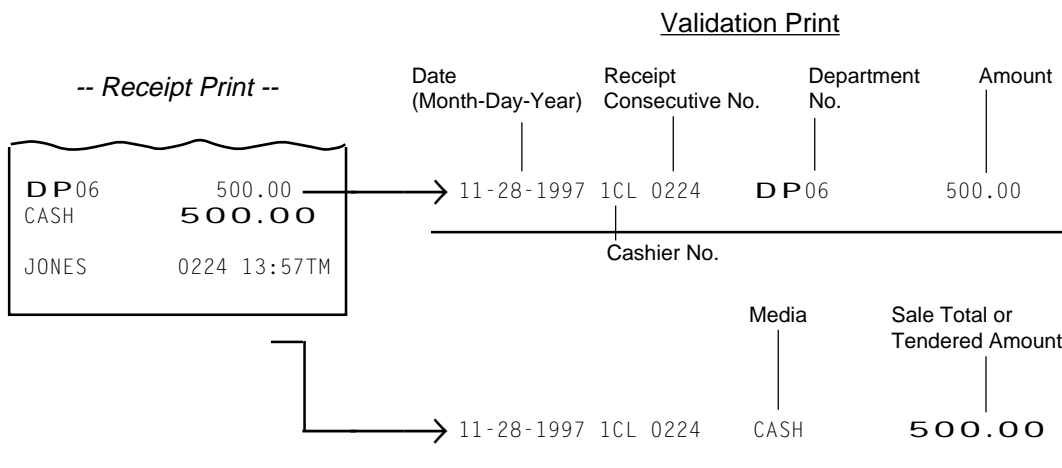

Remote Slip Printer (hardware option) Operation

The TEC Remote Slip Printer DRS-207 may be connected to the MA-1350-1 series ECR as an optional device. The Remote Slip Printer will operate printing if a slip is properly inserted, regardless of the Mode Lock position (except that no print will occur in the "SET" mode or during program verification in the "X" mode).

1. The remote slip printer will automatically activate printing when the slip has properly been set to the printer table.
2. The gap of the slip inlet is usually opened, and the slip may be inserted or withdrawn freely outside a receipt/journal print sequence.
When a slip is properly set to the remote slip printer and the ECR is operated, the gap will be closed and printing will be performed. When the sale is finalized and the receipt is issued, the gap of the DRS-207 will be opened to allow the slip withdrawal. (The gap keeps closed during sale item entries.)
3. The RELEASE key on the DRS-207 may be used to open the closed gap in order to withdraw the slip and skip unnecessary item printer is in a printing action.
4. Printing on the remote slip will be performed alternately with printing on the receipt/journal of the ECR.

-- Receipt Print --

TEC STORE
1343 PEACH DRIVE
PHONE: 87-6437

Open 8:00am to 7:00pm
Closed: every Wednesday

11-28-1997 #112300

MEAT		7.00	TF
3X	5.00	@	
Salmon		15.00	TF
8X	3.00/	8	
Bun-A		3.00	T
DRINK		15.00	T
SUBTL		40.00	
TAX		4.25	
Chg		44.25	

JONES 0225 14:44TM

Remote Slip Print

MEAT		7.00	TF
3X	5.00	@	
Salmon		15.00	TF
8X	3.00/	8	
Bun-A		3.00	T
DRINK		15.00	T
SUBTL		40.00	
TAX		4.25	
Chg		44.25	

11-28-1997 1CL 0224 JONES 0225 14:44TM

14. Paper Roll Replacement and Other Maintenance

When a red line appears on the edge of the paper roll, follow the steps below to replace the paper roll with a new one.

WARNING!

Care must be taken not to injure yourself with the paper cutter.

Replacing the Receipt Roll

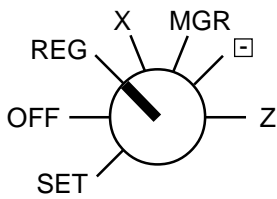

1

Turn the Control Lock to the **REG** position using the Control Key.

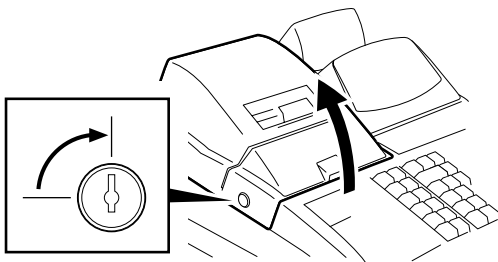

2

To remove the Printer Cover, insert the Printer Cover Key to the Printer Cover Lock, and then turn it 90° clockwise.

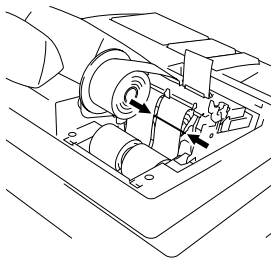

3

Cut the paper as shown in the figure.

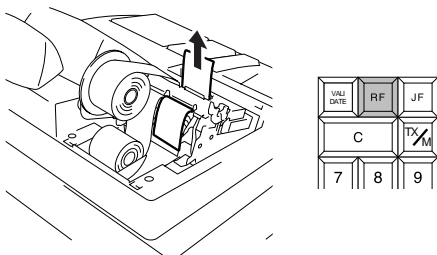

4

Depress the **[RF]** key to feed the remaining paper end.

CAUTION: *Never try to pull out the remaining paper end by hand. It may cause a paper jam.*

5

Load new paper roll as described in Chapter 8 on page 12.

Replacing the Journal Roll

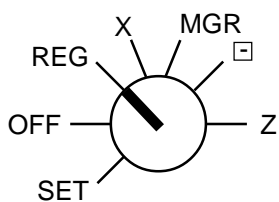

1

Turn the Control Lock to the **REG** position using the Control Key.

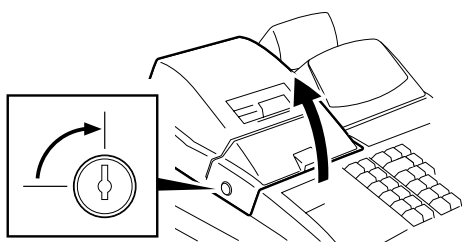

2

To remove the Printer Cover, insert the Printer Cover Key to the Printer Cover Lock, and then turn it 90° clockwise.

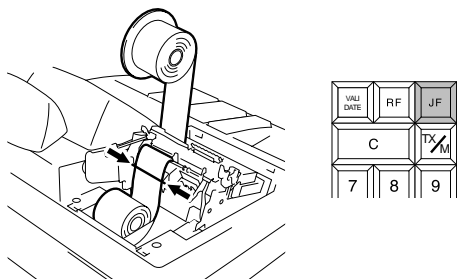

3

Depress the **[JF]** key to wind up enough of the Journal Paper, then cut the paper as shown in the figure.

Depress the **[JF]** key to feed the remaining paper end.

CAUTION: Never try to pull out the remaining paper end by hand. It may cause a paper jam.

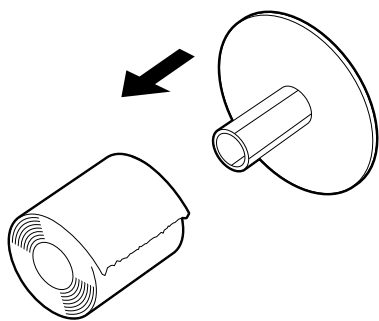

4 Remove the wound-up portion of the paper by pulling it sideways.

5 Load new paper roll as described in Chapter 8 on page 12.

Replacing the Ribbon Cassette

This Ribbon Cassette is a consumable part and a TOSHIBA TEC's exclusive. Ask your TOSHIBA TEC representative about the order of the Ribbon Cassette.

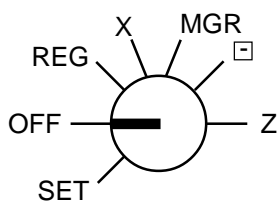

1 Turn the Control Lock to the **OFF** position using the Control Key.

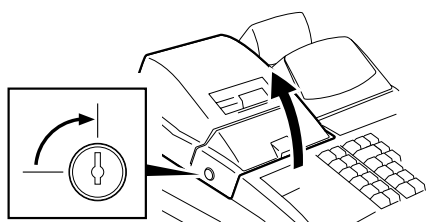

2 To remove the Printer Cover, insert the Printer Cover Key to the Printer Cover Lock, and then turn it 90° clockwise.

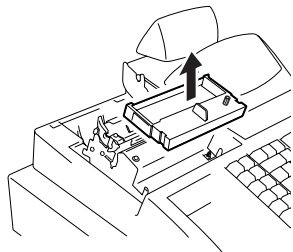

- 3** Remove the old Ribbon Cassette by pulling it in the direction of the arrow mark.

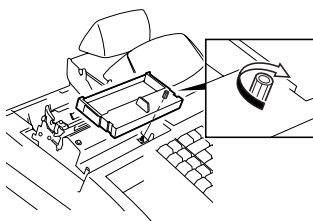

- 4** Install a new one as shown in the figure. After installing the Ribbon Cassette, turn the knob of the Ribbon Cassette in the direction of the arrow mark several times to remove the slack on the ribbon.

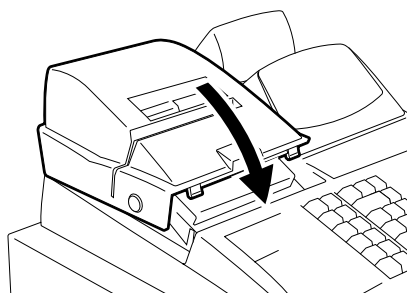

- 5** After replacing the Ribbon Cassette, attach the Printer Cover.

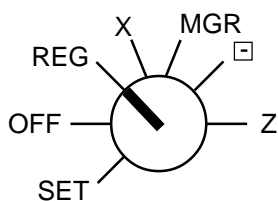

- 6** Turn the Control Lock to the **REG** position using the Control Key, then depress the **[/NS]** key to check the print condition.

Replenishing Ink to the Store Name Stamp

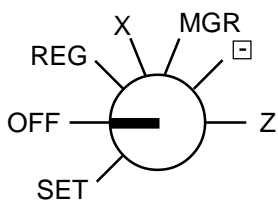

- 1** Turn the Control Lock to the **OFF** position using the Control Key.

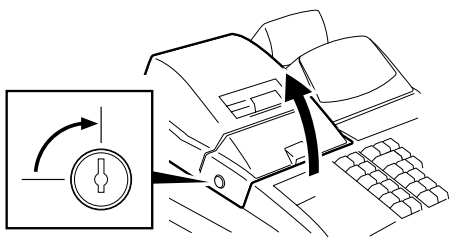

2

To remove the Printer Cover, insert the Printer Cover Key to the Printer Cover Lock, and then turn it 90° clockwise.

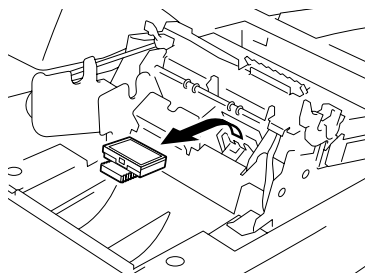

3

Remove the Store Name Stamp by pulling it in the direction of the arrow mark.

Apply ink from the shaded places.

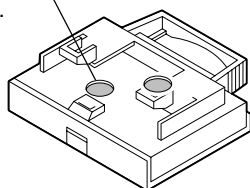

4

Apply only two or three drops. Stamp may not print dark immediately. Allow time for ink to saturate the stamp.

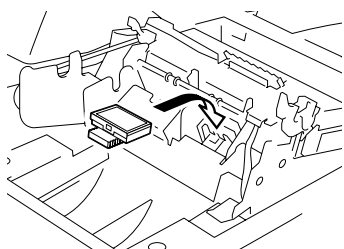

5

Install the stamp by inserting it in the direction of the arrow mark.

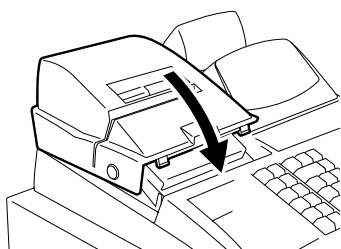

6

Attach the Printer Cover.

7

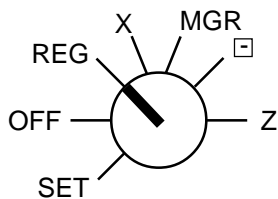

After replenishing ink, depress the [#NS] key to check the density of the printed message.

Manual Drawer Release and Lock

The drawer opens automatically when a registration is performed. In the event of a power failure or other trouble, the drawer can be opened manually in the following manner.

WARNING!

When opening the cash drawer, be careful not to let the drawer hit any person.

Releasing

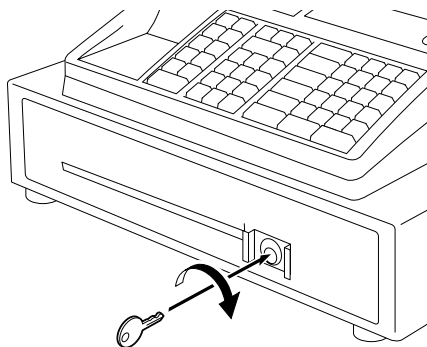

Remove the CDC Cap.
Insert the Drawer Release Key into the Drawer Release Lock, then turn the key clockwise. The drawer will now open.
The Drawer Release Key can be taken out by returning it to the original position.

Locking

When the drawer is closed, it is automatically locked and will not open without the Drawer Release Key or transaction entries.

Removing the Drawer

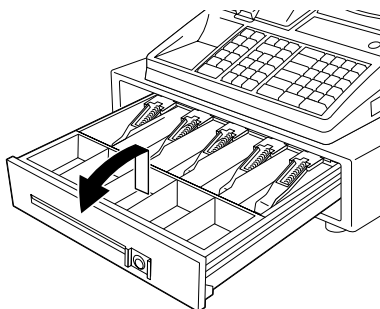

1

Pull the drawer out, and when it stops by the stopper, lift the drawer up and pull it again.

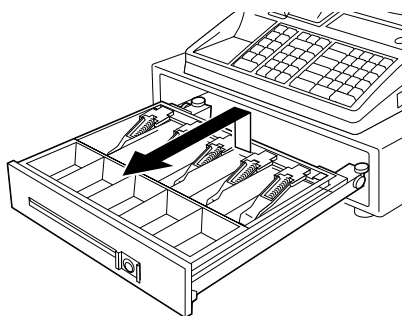

2

When it stops again by the roller fixed in the drawer case, lift it and pull it again.

Media Slot

The Media Slot provided at the front of the drawer is used to put non-cash media such as check in the drawer without opening it. The non-cash media put from this slot are kept under the Money Case, therefore you can keep them in secret.

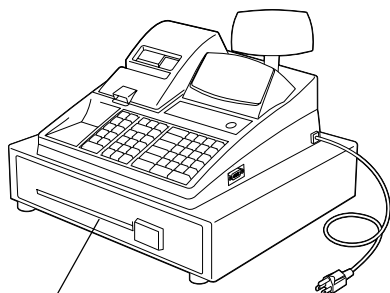

Media Slot

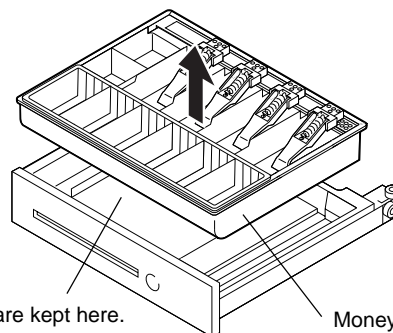

Non-cash media are kept here.

Money Case

CDC (Cash Drawer Cover; Option) Lock

Locking

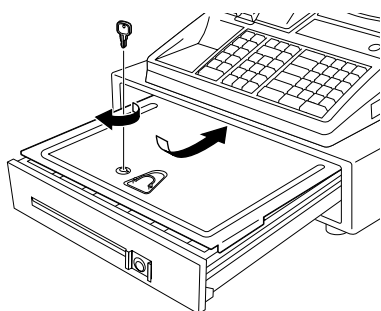

1

Push the Cash Drawer Cover to the back of the drawer.

2

Press the cover lightly, insert the key into the key hole on the cover, and turn it 90° clockwise.

Unlocking

Unlock the cover using the key, and lift the front end.

15. In Case of the Power Failure

If a power failure occurs during business hours, all sales data stored in the memory are automatically protected by the batteries installed in the register. When any data was being printed on the power failure, the same data is automatically printed at the power recovery. In case of the power failure, it is suggested to check the receipt print contents before you hand the receipt to the customer.

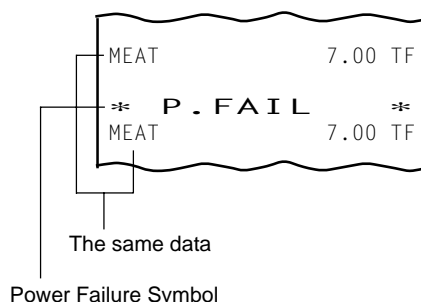

16. Troubleshooting

The following are possible causes and measures against typical troubles. When a trouble occurs, refer to this chapter to find a cause of the trouble, then take appropriate measures. If a trouble not described here occurs, or a trouble still exists after taking the following measures, ask the store where purchased. In this case, inform the store where purchased of your trouble in details.

WARNING!

If you cannot solve a problem with the following solutions, do not attempt to repair it yourself. Turn the power off, then contact your TOSHIBA TEC representative for assistance.

1. Trouble concerning Power Supply
2. Trouble concerning Printer
3. Trouble concerning Keyboard
4. Trouble concerning Drawer
5. Trouble concerning Display
6. Trouble during Normal Operations
7. Trouble in the REG Mode
8. Trouble in the SET Mode

1. Trouble concerning Power Supply

Power is not turned ON.

Cause 1: Register is not plugged in.

Measure: Plug in an outlet.

Cause 2: Control Lock is in the OFF position.

Measure: Turn the Control Lock to the positions other than OFF using the Control Key.

Cause 3: The outlet does not supply the power.

Measure: Use another outlet.

2. Trouble concerning Printer

Printer does not perform the paper feeding.

Cause 1: Paper roll is not placed correctly.

Measure: Place the paper roll correctly. (Refer to page 12.)

Cause 2: Paper fragment or foreign substance blocks the inside of the paper path.

Measure: Printer provided for this register is a precision machine, therefore ask the store where purchased.

Cause 3: Failure of the printer itself

Measure: Ask the store where purchased.

Paper roll wrinkles.

Cause 1: Paper roll is not placed correctly, or placed on the skew.
Measure: Place the paper roll correctly. (Refer to page 46.)

Cause 2: Failure of the printer itself
Measure: Ask the store where purchased.

Printer prints nothing.

Cause 1: Ribbon cassette is not installed.
Measure: Install the ribbon cassette. (Refer to page 15.)

Cause 2: Ribbon cassette reaches its life, deteriorates, or is damaged.
Measure: Replace the ribbon cassette with a new one.

Cause 3: Status lamp "R OFF" is illuminated. (In case that nothing is printed on the receipt but not the journal)
Measure: Depress the [LOG/RECEIPT] key to extinguish the lamp.

Cause 4: Failure of the printer itself
Measure: Ask the store where purchased.

Printing as a whole is too light.

Cause 1: Ribbon cassette reaches its life, deteriorates, or is damaged.
Measure: Replace the ribbon cassette with a new one. (Refer to page 48.)

Printing gets stained.

Cause 1: Printer gathers paper dust.
Measure: It is necessary to clean the inside of the printer, therefore ask the store where purchased.

Printing is uneven or too light.

Cause 1: Ribbon cassette reaches its life, deteriorates, or is damaged.
Measure: Replace the ribbon cassette with a new one. (Refer to page 48.)

Abnormal sound generates.

Cause 1: Paper roll or Ribbon cassette is not placed correctly.
Measure: Place the paper roll or ribbon cassette correctly. (Refer to page 46 or 48.)

Cause 2: Failure of the printer itself
Measure: Ask the store where purchased.

Stamp does not work.

Cause 1: Stamp is not installed correctly.
Measure: Install the stamp correctly. (Refer to page 49.)

Cause 2: Failure of the stamp mechanism
Measure: Ask the store where purchased.

Print of the stamp is too light.

Cause 1: Stamp ink is not enough.
Measure: Replenish the ink. (Refer to page 49.)

Paper jam has occurred.

Cause: Paper roll is placed on the skew, or foreign substance exists in the paper path of the inside of the printer.

Measure: Remove the jammed paper as follows.

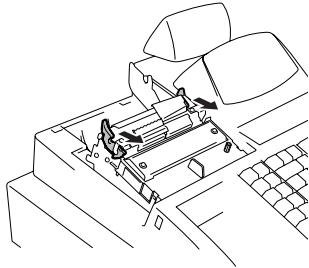

1

To open the upper side of the printer, press simultaneously two levers (green) provided on both sides of the printer in the direction of the arrow.

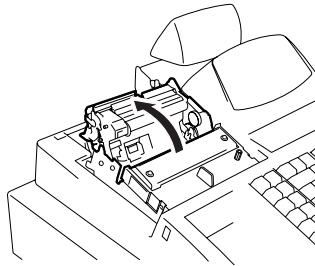

2

Raise up the upper side of the printer in the direction of the arrow, then remove the jammed paper. After removing it, return the upper side of the printer until it clicks.

3. Trouble concerning Keyboard

Key on the keyboard does not function.

Cause 1: Control Lock is in the OFF position.

Measure: Turn the Control Lock to the positions other than OFF using the Control Key.

Cause 2: Failure of the keyboard itself

Measure: Ask the store where purchased.

4. Trouble concerning Drawer

Drawer does not open.

Cause 1: Drawer catches foreign substance (coin, etc.).

Measure: Try to open the drawer by removing the foreign substance, using a ruler or something. If not effective, ask the store where purchased.

Cause 2: Failure of the drawer itself

Measure: Ask the store where purchased.

5. Trouble concerning Display

Display displays nothing.

Cause 1: Register is not securely plugged in.

Measure: Securely plug in an outlet.

Cause 2: Control Lock is in the OFF position.

Measure: Turn the Control Lock to the positions other than OFF using the Control Key.

Some segment is not displayed, display shimmers, or illumination of the display is uneven.

- Cause 1: Failure of the LED
- Measure: Ask the store where purchased.

6. Trouble during Normal Operations

NOTE on changing the Control Lock position:

Changing the Control Lock position during sales entries or programming causes an error. To clear the error, return the Control Lock to the original position. However, changing the Control Lock position to the OFF does not cause an error. Error caused by changing the Control Lock position cannot be cleared by the [C] key.

Normal operations cannot be carried out.

- Cause 1: Control Lock position does not correspond to the operation you attempted.
- Measure: Check whether or not the Control Lock position corresponds to the operation. (Especially, check whether or not the operation you attempted requires the MGR position. Ask your manager about the operations which requires the MGR position.)

Error tone beeps

- Cause 1: Operation procedure is incorrect.
Measure: Depress the [C] key to clear the error, then check the operation procedure you attempted.

- Cause 2: Control Lock position is incorrect.
Measure: Turn the Control Lock to the correct position using the Control Key.

- Cause 3: Operation in the REG position was attempted while the drawer remained open. (In case that the Drawer-close Compulsory Option has been selected.)
Measure: Close the drawer, then depress the [C] key.

7. Trouble in the REG Position

Operations in the REG position cannot be carried out.

- Cause 1: Control Lock is not in the REG position.
Measure: Turn the Control Lock to the REG position using the Control Key.

- Cause 2: Cashier Identifying Operation was not performed when the Cashier Identifying Option has been selected.
Measure: Perform the sign-ON or set the Cashier Key ON. (Refer to page 17.)

- Cause 3: Operation was attempted while the drawer remained open. (In case that the Drawer-close Compulsory Option has been selected.)
Measure: Close the drawer, then depress the [C] key.

- Cause 4: Operation you attempted requires the MGR position.
Measure: Depress the [C] key, and ask your manager whether the operation requires the MGR position. If required, ask your manager to turn the Control Lock to the MGR position.

- Cause 5: You ignored the validation print when the Validation Compulsory Option has been selected to the last operation you attempted. (In this case, the status lamp "SLP" flickers.)
Measure: Depress the [C] key, and perform the validation print.

- Cause 6: After performing the validation print, you attempted the next operation while the validation slip remained in the validation slot.
Measure: Depress the [C] key, and pull out the validation slip from the validation slot.

8. Trouble in the SET Position

Operations in the SET position cannot be carried out.

Cause 1: Control Lock is not in the SET position.

Measure: Turn the Control Lock to the SET position using the Control Key.

Cause 2: Condition for the programming is not satisfied.

Measure: Check the condition for the programming .

Cause 3: Operation procedure is incorrect.

Measure: Check the operation procedure you attempted.

17. Specifications

Size	460 mm (width) x 400 mm (depth) x 305 mm (height including rubber feet) (or 337 mm (height) when Customer's Display is popped up.)
Weight	13.5 kg
Power Required	117V \pm 10 %, 60Hz \pm 10 %
Power Consumed	19W \pm 20 % (operating), 9W \pm 20 % (non-operating)
Ambient Temperature	0°C to 40°C
Relative Humidity	10% to 90% RH (non-condensing)
Size of Receipt and Journal Rolls	45 mm (width) x max. 80 mm (diameter)
Validation Slip Spec.	
Number of Sheets	max. 2 sheets (original + duplicate)
Thickness	Non-carbon Slip 0.07 mm to 0.14 mm Carbon Slip 0.14 mm or less for total thickness of original sheet and duplicate sheet
Size	70 mm or more in height, 135 mm to 210 mm in width
* Use a slip which has no curl (especially on edges), no bend, no wrinkle.	

Memory Protection

Long-lasting rechargeable lithium battery for memory protection.

Specifications are subject to change without notice.

MANAGER'S GUIDE

TABLE OF CONTENTS

	Page
1. Operations in “MGR” Mode	1
Items programmed to require Manager Intervention	1
Listing Capacity Release	2
2. Operations in “ □ ” Mode	3
3. Read and Reset Reports	4
Daily Reports	4
Periodical Reports	5
Report Sample Format	5
4. Changing the Programmed Data	17
Character Entries for Programming Operations:	17
Character Code Entry Method:	18
Direct Character Entry Method:	19
Condition for Programming Operations:	22
Store Message and Commercial Message Programming	23
Cashier Name Programming	26
Department Status Programming	27
PLU Table Setting, Changing, or Deletion	29
Time Setting or Adjustment	32
Date Setting or Adjustment	32
PLU Preset-code Key Setting	33
Department Preset Price Setting or Changing	35
PLU Preset Price Changing	36
% Key Preset Rate Setting or Changing	37
Register No. Setting	38
Foreign Currency Exchange Rate Setting	38
Listing Capacity Setting for Tender Media	39
Vendor Coupon Limit Amount Setting	40
5. Program Data Verification	41
Operating Procedure	41
Appendix	46

1. Operations in “MGR” Mode

This chapter describes operations to be performed in the “MGR” position of the Control Lock, which the Store Manager can access using the MGR or MA key.

Items programmed to require Manager Intervention

During daily sale entry operations, the cashier may call for Manager Intervention. The following is the operation flow of Manager Intervention.

- 1) During operations, the cashier comes across an item that requires Manager Intervention. The cashier, already informed of it, may immediately call for Manager Intervention. Or the cashier, without knowing of it, attempts the operation, and an error results, clears the error by the **[C]** key, and then calls for Manager Intervention.
- 2) The Store Manager goes to the cashier counter with the **MGR** or **MA** key.
- 3) The cashier explains what kind of operation is to be entered and removes the **REG** key from the Control Lock at the “**REG**” position.
- 4) The Store Manager insert the **MGR** or **MA** key and turns it to the “**MGR**” position.
- 5) The cashier operates the required item.
- 6) The Store Manager returns the **MGR** or **MA** key to the “**REG**” position and pulls it out.
- 7) The cashier returns the **REG** key to the “**REG**” key position and continues sale entry operations.

The following are the tables of the keys and operations that are programmable with Manager Intervention. Fill in the tables by marking in the “Not required” or “Required” column of each item.

Keys and Manager Intervention Status

KEY	MGR Position		Reference
	Not required	Required	
[RTN MDSE]			As for the key status change, ask your TOSHIBA TEC representative.
[PO]			
[DOLL DISC]			
[%-] (% I, % II)			
[EX]			
[ALL VOID]			
[VND CPN]			
[STR CPN]			

NOTE: As for the initial status of the respective keys shown above, **MGR** position “Not Required” status is programmed to all of them.

Operations and Manager Intervention Status

OPERATION	MGR Position		Reference
	Not required	Required	
Credit Balance (over-subtraction of the sale by [DOLL DISC] , [VND CPN] , [STR CPN] and [VOID] keys)			As for the status change, ask your TOSHIBA TEC representative.
Negative Department or negative PLU Entries			
Negative-balance Sale Finalization by Non-cash Media Kyes.			

- NOTES:**
1. As for the initial status of the respective operation items shown above, **MGR** position “Required” status is programmed only to “Credit Balance”.
 2. “Credit Balance” is not applied to the **[RTN MDSE]** key, negative department, and negative PLU.

Listing Capacity Release

Listing Capacities (amount limits) may be programmed on Departments (each open-price PLU is ruled by the Listing Capacity of its link Department) and Tender Media. These LCs (Listing Capacities) are programmed to check an excessively high amount entry by cashier’s mistake at the earliest stage. Guide your cashiers as in the following procedure:

- 1) During sale entries by a cashier, an error occurs when a Department or PLU item has been entered, or a media key has been depressed.
- 2) The cashier clears the error by the **[C]** key. The cashier confirms the amount and operates the item again.
- 3) If the same error occurs again, the cashier attempts to enter the amount using the **[LC OPEN]** or **[OPEN]** key.
- 4) If the operation results in an error again, it means that the amount still cannot be entered by the **[LC OPEN]** or **[OPEN]** key function.
- 5) The cashier calls for Manager Intervention.

The procedure thereafter is the same as Steps 2) to 7) for the Items programmed to require Manager Intervention on the preceding page.

Reference: For reading the Listing Capacity of each Department:
Chapter 5. **Program Data Verification** — Department LC and Status Read
For setting the Listing Capacities of specific Departments:
Ask your TOSHIBA TEC representative.
For reading the Listing Capacity of each Tender Media Key:
Chapter 5. **Program Data Verification** — Other Programmed Data Read
For setting the Listing Capacities of the specific Tender Media Keys:
Chapter 4. **Changing the Programmed Data** — Listing Capacity Setting for the Tender Media

2. Operations in “ □ ” Mode

This chapter describes operations to be performed in the “ □ ” position of the Control Lock, which the Store Owner or a person so authorized can access using the MA key.

Instead of using the [RTN MDSE] or [VOID] keys in the “REG” or “MGR” mode for deleting individual sale items, the “ □ ” mode automatically processes positive items into negative and negative into positive. To operate, turn the Mode Lock to the “ □ ” position using the MA key, and enter the items, one by one, just as in the “REG” mode as reading the sale receipt (issued at the time of the purchase) or tracing the returned items as if the “REG” mode. A positive balance resulted in the “ □ ” mode indicates the amount to be paid back to the customer. The “ □ ” mode operation may occur from time to time during the day, on the cashier’s request, just as in the case of ordinary Manager Interventions, when a customer comes to the cashier counter to return or cancel all the items that were once purchased and finalized (in which case the All Void operation is no longer effective).

Receipt Samples in “REG” and “ □ ”

Receipt issued in “REG” or “MGR” Mode

MEAT	7.00	TF
%-		
5%	0.35-	
FISH	5.50	TF
%+		
10%	0.55	
SUBTL	12.70	
TAX	0.90	
CASH	13.60	
JONES	0240	11:20TM

These two receipts contain the same sale items and media finalization. The operations are also the same except the Control Lock position.

The cashier merely follows the purchase receipt (on the left) and enters the same items in the “ □ ” mode finalizing with the same media, in case the customer has returned or canceled the entire sale after once finalized that sale.

Receipt issued in “ □ ” Mode

≡ REG -		≡
MEAT	7.00	TF
%-		
5%	0.35-	
FISH	5.50	TF
%+		
10%	0.55	
SUBTL	12.70	
TAX	0.90	
CASH	13.60	
≡ REG -		≡
JONES	0243	11:21TM

“ □ ” mode Receipt Header

NOTE: In the “ □ ” mode the Listing Capacities and the status requiring Manager Intervention will all be released, i.e., the same handing as in the “MGR” mode.

3. Read and Reset Reports

This chapter describes the operation to take each report and its contents.













- The Read (X) reports allow to read the totals but not clear the memory, while the Reset (Z) reports allow to read the totals and, at the same time, clear all the resettable totals when the report has been taken.
- The symbol “X” is printed at the top of Read Reports, while “Z” is printed on Reset Reports to indicate the type of report.
- Reset Report Counter is printed on each Reset Report only.
- The daily report covers data obtained during a certain period on that day until the corresponding Reset Report was printed, while the periodical report covers data obtained during a certain period defined by the store.
- When you take a read report, the “R OFF” lamp must be extinguished. If it is illuminated, press the **[LOG/RECEIPT]** key to extinguish the lamp. As for a reset report, it can be issued even if the “R OFF” lamp is illuminated.

CAUTION: Whenever you turn the Control Lock to “Z” position, be sure that you are taking Reset Reports (final reports) and that the sales data will be cleared by the operation to follow.







WARNING!

When opening the cash drawer, be careful not to let the drawer hit any person.

Daily Reports

Report Name	Key Operation	Sample Page
* Financial Read * Financial Reset	Control Lock: X  → AT/TL Control Lock: Z  → AT/TL	6
Hourly Sales Read Hourly Sales Reset	Control Lock: X  → 10 AT/TL Control Lock: Z  → 10 AT/TL	12
All Department Read (NOTE 2) All Department Reset (NOTE 2)	Control Lock: X  → 11 AT/TL Control Lock: Z  → 11 AT/TL	13
Department Gross Profit Read	Control Lock: X → 12 AT/TL	14
All PLU Sales Read All PLU Sales Reset	Control Lock: X  → PLU Control Lock: Z  → PLU	14
Zone PLU Sales Read Zone PLU Sales Reset	Control Lock: X  → <input type="text"/> <input type="text"/> <input type="text"/> @/FOR <input type="text"/> <input type="text"/> <input type="text"/> PLU Control Lock: Z  → <input type="text"/> <input type="text"/> <input type="text"/> @/FOR <input type="text"/> <input type="text"/> <input type="text"/> PLU <small>Zone-start PLU Code Zone-end PLU Code</small>	14
* Media Sales and In-drawer Read	Control Lock: X → #/NS (or #/CID , #)	12
* Individual Cashier Read (NOTE 3) * Individual Cashier Reset (NOTE 3)	Control Lock: X  → <u>Cashier Signing Method</u> Control Lock: Z  → <input type="checkbox"/> LOG RECEIPT Cashier Code: 1 to 8  → <u>Cashier Key Method</u> Set the required Cashier Key ON, then 1 AT/TL	15

Periodical Reports

Report Name	Key Operation	Sample Page
* Financial Read * Financial Reset	Control Lock: X  → 2 0 AT/TL Control Lock: Z  → 2 0 AT/TL	6
* All Cashier Read (NOTE 3) * All Cashier Reset (NOTE 3)	Control Lock: X  → 4 AT/TL Control Lock: Z  → 4 AT/TL	16
All Department Read (NOTE 2) All Department Reset (NOTE 2)	Control Lock: X  → 2 1 AT/TL Control Lock: Z  → 2 1 AT/TL	13
Department Gross Profit Read	Control Lock: X → 2 2 AT/TL	14

- NOTES:**
1. The cash drawer will open on the final key of the key operation for the reports marked with “**”.
 2. All Department Read and Reset Reports can be issued when the program option “Issuing Department Reports separately from Financial Reports” is selected. (Ask your TOSHIBA TEC representative.)
 3. Cashier Read and Reset Reports can be issued only when the Cashier Identifying Option (Signing Method; Cashier Sign ON & Sign OFF, Cashier Key Method; Push LED Key, Barrel Lock, [CLK] Key) is selected. Refer to **Chapter 11** on page 17 in Operator’s Guide.

Report Sample Format

On the following pages are sample formats of respective reports. In referring to those formats, please note the following conditions:

- In each report format, all the items that can be programmed to print are placed.
- The data contents are merely examples to show the report format. The numeric data may not balance correctly. (Refer to the “**Memory Balance**” attached to the Daily Financial Read or Reset Report.) Neither the programmed contents nor sales data placed as examples in various operating procedures in **Chapters “13. Transaction Entries”** on page 21 in Operator’s Guide and “**4. Changing the Programmed Data**” on page 17 in Manager’s Guide or any other chapters are related to the numeric data in the report formats.

Financial Read or Reset Report (Daily or Periodical)

TEC STORE	
1343 PEACH DRIVE PHONE: 87-6437	
Open 8:00am to 7:00pm Closed: every Wednesday	
11-28-1997	#112300
GT	Z
10105581.31	
NET GT	10106672.51
GS	185
	988.46
MEAT	44
31CU	244.10
46.97%	
FISH	40
18CU	134.61
25.90%	
DRINK	25
31CU	59.90
11.53%	
BAKERY	33
12CU	81.11
15.61%	
DP05	5
5CU	-7.50
DP06	3
3CU	1200.00
TOTAL	142
	512.22
FRESH F	84
22.12%	378.71
DR & BA	58
8.24%	141.01
OTHERS	8
69.65%	1192.50
TOTAL	150
	1712.22
%+	1
	1.50
NS	142
	513.72
GST	0.00
TAX1	18.13
TAX2	17.63
TAX3	18.13
TAX4	17.63
EX GST	0.00
NS	142
	549.60
HASH TL	3
	1200.00
%-	2
	2.80
V.CPN	1
	1.00
DISC	1
	0.40
TOTAL	
60CU	1745.40

NOTE on page 8

Date, Register No. _____

Report Type Symbol _____

X: Daily Read
Z: Daily Reset
GTX: Periodical Read
GTZ: Periodical Reset

Grand Total (non-resettable) (Initial Status: Print)

NET GT (non-resettable) (Initial Status: Non-print)

Gross Sale: Item Count
Amount

Department 1 (MEAT): Item Count
Customer Count (Initial Status: Print), Amount
Sales Ratio (Initial Status: Print)

Department 2 (FISH) Data

Department 3 (DRINK) Data

Department 4 (BAKERY) Data

Department 5 Data; Negative status department is excluded from the sales ratio calculation.

Department 6 Data; Other income department is excluded from the sales ratio calculation.

Total of all departments (excluding negative and other income depts.): Item Count
Amount

Department Group 1 (FRESH F): Item Count
Sales Ratio (Initial Status: Print), Amount

Department Group 2 (DR & BA) Data

Department Group 3 (OTHERS) Data

Total of all department groups (Initial Status: Non-print): Item Count
Amount

Percent Charge: Count
Amount

Net Sales without Tax (Initial Status: Non-print): Item Count
Amount

GST (exclusive) Amount (Print for the GST feature)

Tax 1 Amount
Tax 2 Amount
Tax 3 Amount
Manual Tax Amount

Exempted GST (inclusive) Amount (Print for the GST feature)

Net Sales with Tax (Initial Status: Print): Item Count
Amount

Total of Other Income Departments: Item Count
(Initial Status: Non-print) Amount

Percent Discount on Subtotal: Count
Amount

Vendor Coupon: Count
Amount

Dollar Discount: Count
Amount

All Media Total: Customer Count, Amount

CASH		Cash Sales: Customer Count, Amount	
44CU	773.43		
CHECK		Check Sales: Customer Count, Amount	
3CU	550.88		
Chg		Charge Sales: Customer Count, Amount	
8CU	336.36		
MISC		Miscellaneous Media Sales: Customer Count, Amount	
1CU	1745.40		
CPN		Media-coupon Sales: Customer Count, Amount	
0CU	773.43		
FS TL		Food Stamp Sales (<i>Print for the Food Stamp feature</i>):	
1CU	550.88	Customer Count, Amount	
R/A	6	Received-on-Account: Count	
	45.00	Amount	
PO	3	Paid Out: Count	
	6.50	Amount	
CASH ID	603.16	Cash-in-drawer Amount	
CHECK ID	7	Check-in-drawer: Count	These items are printed on Daily Reports only but not on Periodical Reports.
	572.00	Amount (<i>Initial Status: Print</i>)	
Chg ID	8	Charge-in-drawer: Count	
	336.36	Amount (<i>Initial Status: Non-print</i>)	
MISC ID	3	Miscellaneous Media-in-drawer: Count	
	23.00	Amount (<i>Initial Status: Print</i>)	
CPN ID	3	Media-coupon-in-drawer: Count	
	15.00	Amount (<i>Initial Status: Print</i>)	
FSID	3	Food Stamp-in-drawer: Count	
	18.00	Amount (<i>Print for the Food Stamp feature</i>)	
FS CG	0.40	Food Stamp Change Amount (<i>Print for the Food Stamp feature</i>)	
CORR	2	Item Correct: Count	
	6.50	Amount	
VOID	2	Void: Count	
	14.00	Amount	
MISC VD	0	Misc. Void (Item Correct and Void on other items than Departments and PLUs):	Count
	0.00		Amount
ALL VD	2	All Void: Count	
	37.40	Amount	
%-	3	Percent Discount on Line Item: Count	
	1.70	Amount	
S.CPN	1	Store Coupon: Count	
	1.00	Amount	
-DP TL	5	Total of Negative Departments: Item Count (<i>Initial Status: Non-print</i>)	
	7.50	Amount	
RTN	5	Returned Merchandise: Item Count	
	22.10	Amount	
-TAX	0.45	Negative Tax Amount	
REG-	1	Negative Mode ("☐" position): Count	
	13.95	Amount	
TRF TL	20.19	Transfer Total (non-resettabale)	
TRF+ GT	20.19	Transfer (+) GT (non-resettabale)	
TRF- GT	0.00	Transfer (-) GT (non-resettabale)	
TRF+	20.19	Transfer (+) Daily	
TRF-	0.00	Transfer (-) Daily	
PB TL			
3CU	30.99	Previous Balance Sales: Customer Count, Amount	
PB R/A	10.80	Previous Balance R/A Amount	
PB PO	0.00	Previous Balance PO Amount	
NON GST	0.00	GST Non-taxable Amount (<i>Print for the GST feature; Initial Status: Print</i>)	
GST TXBL	222.43	Sale Total subject to GST (<i>Print for the GST feature</i>)	
GST INC	15.57	GST (inclusive) Amount (<i>Print for the GST feature</i>)	
TXBL1	362.31	Sale Total subject to Tax 1	
TXBL2	85.60	Sale Total subject to Tax 2	
TXBL3	0.00	Sale Total subject to Tax 3	
TAX EX			
2CU		Tax Exempted Customer Count	
GST EX	0.00	GST Exempt Amount (<i>Print for the GST feature</i>)	
TAX1EX	24.50	Tax 1 Exempt Amount	
TAX2EX	8.50	Tax 2 Exempt Amount	
TAX3EX	0.00	Tax 3 Exempt Amount	

FS EX1	0.00	Food Stamp Tax 1 Exempt Amount	} (Printed only when ILLINOIS or NEW JERSEY type of Food Stamp feature is selected.)
FS EX2	0.00	Food Stamp Tax 2 Exempt Amount	
FS EX3	0.00	Food Stamp Tax 3 Exempt Amount	
N. NS	0.00	New Net Sales Amount	(Print for the GST feature)
CUR1	2	Foreign Currency 1-in-drawer:	Count
	120.00		Amount
CUR2	1	Foreign Currency 2-in-drawer:	Count
	15.00		Amount
NO SALE	2	No-sale Count	(Initial Status: Non-print)
VALI CTR	6	Validation Print Count	(Initial Status: Non-print)
MEAT		Department 1 (MEAT)	
10.00%	24.41	Gross Profit Rate, Amount	
FISH		Department 2 (FISH)	
15.00%	20.19	Gross Profit Rate, Amount	
DRINK		Department 3 (DRINK)	
20.00%	11.98	Gross Profit Rate, Amount	
BAKERY		Department 4 (BAKERY)	
25.00%	20.27	Gross Profit Rate, Amount	
TOTAL		Average Gross Profit Rate, Total of Gross Profit Amount	
14.79%	76.85	Reset Count of this Reset Report	(printed on Reset Report only)
0006Z		Receipt Consecutive No., Current Time	
	0263 20:37TM		

NOTE: Initially, department and department group data is printed on the Financial Report as shown in the sample. However, the data can be issued separately from the Financial Report. (Refer to All Departments Read or Reset Report shown on page 13.)

- Memory Balance -

Memory Balance applicable to the US Version

Grand Total = Sum of Daily Gross Sales

NET GT = Sum of Daily All Media Sales

Gross Sales = (Sum of Depts.; **NOTE 1**) + (Sum of Taxes) + (Percent Charge)
+ (Percent Discount on Line Item) + (Sum of Negative Depts.) + (Item Correct)
+ (Void) + (Returned Merchandise) + ("☐" Mode) + (Store Coupon)
+ (All Void; **NOTE 2**) + (Negative Tax)

Net Sales with Tax = (Sum of Depts.; **NOTE 1**) + (Sum of Taxes) + (Percent Charge)
= (Gross Sales) - (Item Correct) - (Void) - (Percent Discount on Line Item)
- (Store Coupon) - (Negative Tax) - (Sum of Negative Depts.)
- (Returned Merchandise) - ("☐" Mode) - (All Void; **NOTE 2**)

All Media Sales = (Net Sales with Tax) - (Percent Discount on Subtotal) - (Vendor Coupon)
- (Dollar Discount) + (Sum of Other Income Depts.)
= (Cash Sales) + (Check Sales) + (Charge Sales)
+ (Miscellaneous Media Sales) + (Media-coupon Sales)
+ (Food Stamp Sales) + (Previous Balance Sales)

Sum of Hourly Range Sales = Net Sales with Tax (US Balance; **NOTE 3**)

Sum of Hourly Range Sales = Net Sales without Tax (CA Balance)

"☐" Mode = (Gross Sales) in the "☐" Mode

Sum of NEG 1 = (Percent Discount on Line Item) + (Sum of Negative Depts.) + (Item Correct)
+ (Void) + (Returned Merchandise) + (Negative Tax) + ("☐" Mode)
+ (All Void; **NOTE 2**) + (Store Coupon)

Sum of NEG 2 = (Percent Discount on Subtotal) + (Dollar Discount) + (Misc. Void)
+ (Vendor Coupon)

- NOTES:**
1. (Sum of Depts.) = (Sum of Positive Depts.) + (Sum of Negative Depts.)
* Other Income Depts. Excluded
 2. (All Void) = (Sum of Positive Depts.) + (Manual Tax) + (Percent Charge)
 3. Applicable when the Daily Financial Reset Report and the Daily Hourly Range Reset Report are taken at the same time.
 4. The same amount processed into the Gross Sales memory is processed into the All Void memory.

Memory Balance applicable to the CA GST (Exclusive) Version

Grand Total = Sum of Daily Gross Sales

NET GT = Sum of Daily All Media Sales

Gross Sales = (Net Sales with Tax) + (Percent Discount on Line Item)
+ (Sum of Negative Depts.) + (Item Correct) + (Void) + (Returned Merchandise)
+ (" ☐ " Mode) + (Store Coupon) + (All Void; **NOTE 2**) + (Negative Tax)

Net Sales with Tax = (Sum of Depts.; **NOTE 1**) + (Percent Charge) + (GST) + (PST; **NOTE 3**)
= (Gross Sales) - (Item Correct) - (Void) - (Percent Discount on Line Item)
- (Store Coupon) - (Negative Tax) - (Sum of Negative Depts.)
- (Returned Merchandise) - (" ☐ " Mode) - (All Void; **NOTE 2**)

All Media Sales = (Net Sales with Tax) - (Percent Discount on Subtotal) - (Vendor Coupon)
- (Dollar Discount) + (Sum of Other Income Depts.)
= (Cash Sales) + (Check Sales) + (Charge Sales)
+ (Miscellaneous Media Sales) + (Media-coupon Sales)
+ (Previous Balance Sales)

Sum of Hourly Range Sales = (Sum of Depts.; **NOTE 1**) + (Percent Charge)
= N.NS (New Net Sales)

" ☐ " Mode = (Gross Sales) in the " ☐ " Mode

Sum of NEG 1 = (Percent Discount on Line Item) + (Sum of Negative Depts.) + (Item Correct)
+ (Void) + (Returned Merchandise) + (Negative Tax) + (" ☐ " Mode)
+ (All Void; **NOTE 2**) + (Store Coupon)

Sum of NEG 2 = (Percent Discount on Subtotal) + (Dollar Discount) + (Misc. Void)
+ (Vendor Coupon)

- NOTES:**
1. (Sum of Depts.) = (Sum of Positive Depts.) + (Sum of Negative Depts.)
* Other Income Depts. Excluded
 2. (All Void) = (Sum of Positive Depts.) + (Manual Tax) + (Percent Charge)
 3. PST = (Sum of Taxes; Taxes 1 to 3 and Manual Tax)
 4. The same amount processed into the Gross Sales memory is processed into the All Void memory.

Memory Balance applicable to the CA GST (Inclusive) Version

Grand Total = Sum of Daily Gross Sales

NET GT = Sum of Daily All Media Sales

Gross Sales = (Net Sales with Tax) + (Percent Discount on Line Item)
+ (Sum of Negative Depts.) + (Item Correct) + (Void) + (Returned Merchandise)
+ ("☐" Mode) + (Store Coupon) + (All Void; **NOTE 2**) + (Negative Tax)
+ (Exempted GST)

Net Sales with Tax = (Sum of Depts.; **NOTE 1**) + (Percent Charge) + (PST; **NOTE 3**)
- (Exempted GST)
= (Gross Sales) - (Item Correct) - (Void) - (Percent Discount on Line Item)
- (Store Coupon) - (Negative Tax) - (Sum of Negative Depts.)
- (Returned Merchandise) - ("☐" Mode) - (All Void; **NOTE 2**)

All Media Sales = (Net Sales with Tax) - (Percent Discount on Subtotal) - (Vendor Coupon)
- (Dollar Discount) + (Sum of Other Income Depts.)
= (Cash Sales) + (Check Sales) + (Charge Sales)
+ (Miscellaneous Media Sales) + (Media-coupon Sales)
+ (Previous Balance Sales)

Sum of Hourly Range Sales = (Sum of Depts.; **NOTE 1**) + (Percent Charge)
- (Exempted GST) - (GST included in Depts.)
= N.NS (New Net Sales)

"☐" Mode = (Gross Sales) in the "☐" Mode

Sum of NEG 1 = (Percent Discount on Line Item) + (Sum of Negative Depts.) + (Item Correct)
+ (Void) + (Returned Merchandise) + (Negative Tax) + ("☐" Mode)
+ (All Void; **NOTE 2**) + (Store Coupon)

Sum of NEG 2 = (Percent Discount on Subtotal) + (Dollar Discount) + (Misc. Void)
+ (Vendor Coupon)

- NOTES:**
1. (Sum of Depts.) = (Sum of Positive Depts.) + (Sum of Negative Depts.)
* Other Income Depts. Excluded
 2. (All Void) = (Sum of Positive Depts.) + (Manual Tax) + (Percent Charge)
 3. PST = (Sum of Taxes; Taxes 1 to 3 and Manual Tax)
 4. The same amount processed into the Gross Sales memory is processed into the All Void memory.

Daily Hourly Sales Read or Reset Report

```

TEC STORE
1343 PEACH DRIVE
PHONE: 87-6437

Open 8:00am to 7:00pm
Closed: every Wednesday

11-28-1997    #112300

      Z 1 O

08:00TM
   1CU           5.00
09:00TM
   4CU           43.35
10:00TM
   14CU          78.55
13:00TM
   24CU          240.96
16:30TM
   18CU          186.74
19:00TM
0001Z

      0252 20:04TM
    
```

X10: Daily Read
Z10: Daily Reset

Report Type Symbol

Sales Data in Hourly Range from 19 : 01 yesterday to 8 : 00 No sales recorded
Sales Data (Customer Count & Amount) in Hourly Range from 8 : 01 to 9 : 00

Sales Data (Customer Count & Amount) in Hourly Range from 9 : 01 to 10 : 00

Sales Data (Customer Count & Amount) in Hourly Range from 10 : 01 to 13 : 00

Sales Data (Customer Count & Amount) in Hourly Range from 13 : 01 to 16 : 30

Sales Data (Customer Count & Amount) in Hourly Range from 16 : 31 to 19 : 00

Reset Count of this Reset Report (printed on Reset Reports only)

Receipt Consecutive No., Current Time

Daily Media Sales & In-drawer Read Report

```

TEC STORE
1343 PEACH DRIVE
PHONE: 87-6437

Open 8:00am to 7:00pm
Closed: every Wednesday

11-28-1997    #112300

      X

TOTAL
  60CU          1745.40
CASH ID         603.16
CHECK ID         7
                572.00
Chg ID           8
                336.36
MISC ID          3
                23.00
CPN ID           3
                15.00
FSID             3
                18.00
CUR1             2
                120.00
CUR2             1
                15.00

      0250 20:00TM
    
```

Report Type Symbol (Daily Read Report only)

Total Customer Count, All Media Sales Amount

Cash-in-drawer Amount

Check-in-drawer: Count
Amount (Initial Status: Print)

Charge-in-drawer: Count
Amount (Initial Status: Non-print)

Miscellaneous Media-in-drawer: Count
Amount (Initial Status: Print)

Media-coupon-in-drawer: Count
Amount (Initial Status: Print)

Food Stamp-in-drawer: Count
Amount (Print for the Food Stamp feature)

Foreign Currency 1-in-drawer: Count
Amount

Foreign Currency 2-in-drawer: Count
Amount

Receipt Consecutive No., Current Time

All Departments Read or Reset Report (Daily or Periodical)

TEC STORE 1343 PEACH DRIVE PHONE: 87-6437 Open 8:00am to 7:00pm Closed: every Wednesday 11-28-1997 #112300 X 1 1	
MEAT	44
31CU	244.10
46.97%	
FISH	40
18CU	134.61
25.90%	
DRINK	25
13CU	59.90
11.53%	
BAKERY	33
12CU	81.11
15.61%	
DP05	5
5CU	-7.50
DP06	3
3CU	1200.00
TOTAL	142
	512.22
FRESH F	84
22.12%	378.71
DR & BA	58
8.24%	141.01
OTHERS	8
69.65%	1192.50
TOTAL	150
	1712.22
MEAT	10.00%
24.41	
FISH	15.00%
20.19	
DRINK	20.00%
11.98	
BAKERY	25.00%
20.27	
TOTAL	14.79%
76.85	
	0254 20:10TM

X11: Daily Read
Z11: Daily Reset
GTX21: Periodical Read
GTZ21: Periodical Reset

Report Type Symbol
 Department 1 (MEAT): Item Count
 Customer Count (Initial Status: Print), Amount
 Sales Ratio (Initial Status: Print)
 Department 2 (FISH) Data

 Department 3 (DRINK) Data

 Department 4 (BAKERY) Data

 Department 5 Data; Negative status department is excluded from the sales ratio calculation.
 Department 6 Data; Other income department is excluded from the sales ratio calculation.
 Total of all departments
 (excluding negative and other income depts.) (Initial Status: Non-print): Item Count
 Amount

 Department Group 1 (FRESH F): Item Count
 Sales Ratio (Initial Status: Print), Amount
 Department Group 2 (DR & BA) Data

 Department Group 3 (OTHERS) Data

 Total of all department groups (Initial Status: Non-print): Item Count
 Amount

 Department 1 (MEAT)
 Gross Profit Rate, Amount
 Department 2 (FISH)
 Gross Profit Rate, Amount
 Department 3 (DRINK)
 Gross Profit Rate, Amount
 Department 4 (BAKERY)
 Gross Profit Rate, Amount

 Average Gross Profit Rate, Total of Gross Profit Amount

 Receipt Consecutive No., Current Time

(Initial Status: Print)
NOTE 2

- NOTES:**
- Initially, department and department group data is printed on the Financial Report as shown in the Financial Report sample on page 6. However, the data can be issued separately from the Financial Report by the program option. (Refer to your TOSHIBA TEC representative.)
 - Data concerning the Department Gross Profit is not printed for the following Departments.
 - Negative Status Department
 - Other Income Department
 - Department which has no sales data
 - Department of which sales data is negative

Department Gross Profit Read (Daily or Periodical)

		X 1 2	
NOTE	MEAT		
	10.00%	24.41	Report Type Symbol { X12: Daily Read
	FISH		Department 1 (MEAT) { GTX22: Periodical Read
	15.00%	20.19	Gross Profit Rate, Amount
	DRINK		Department 2 (FISH)
	20.00%	11.98	Gross Profit Rate, Amount
	BAKERY		Department 3 (DRINK)
25.00%	20.27	Gross Profit Rate, Amount	
TOTAL			Department 4 (BAKERY)
14.79%	76.85		Gross Profit Rate, Amount
			Average Gross Profit Rate, Total of Gross Profit Amount
		0255 20:13TM	Receipt Consecutive No., Current Time

NOTE: Data concerning the Department Gross Profit is not printed for the following Departments.

- Negative Status Department
- Other Income Department
- Department which has no sales data
- Department of which sales data is negative

Daily PLU Read or Reset Report (All or Zone)

Daily All PLU Read or Reset Report

		Z	
0100	Pork		Report Type Symbol { X: Daily Read
8		16.00	PLU Code 100 (Pork) { Z: Daily Reset
0101	Beef		Item Count, Amount
3		9.00	PLU Code 101 (Beef)
0200	Salmon		Item Count, Amount
6		30.00	PLU Code 200 (Salmon)
0201	Shrimp		Item Count, Amount
9		18.00	PLU Code 201 (Shrimp)
0300	Coke-A		Item Count, Amount
15		12.00	PLU Code 300 (Coke-A)
0301	Boke-B		Item Count, Amount
4		4.00	PLU Code 301 (Coke-B)
0400	Bun-A		Item Count, Amount
12		4.51	PLU Code 400 (Bun-A)
0401	Bun-B		Item Count, Amount
11		5.50	PLU Code 401 (Bun-B)
0500	PLU500		Item Count, Amount
1		-0.50	PLU Code 500
			Item Count, Amount
TOTAL			Total of all PLUs
68		98.51	Item Count (Positive PLUs only), Amount (Positive PLUs + Negative PLUs)
0001Z			Reset Count of this Reset Report (including the Zone Reset)
			(printed on Reset Reports only)
		0256 20:15TM	Receipt Consecutive No., Current Time

Daily Zone PLU Read or Reset Report

The format is the same as "All PLU Read or Reset Report" above. The only difference is that the **Zone Read or Reset Report** outputs only the PLUs in the zone designated by the key operation to take the report.

Cashier Read or Reset Report (Daily or Periodical)
Daily Cashier Read or Reset Report

TEC STORE
 1343 PEACH DRIVE
 PHONE: 87-6437

 Open 8:00am to 7:00pm
 Closed: every Wednesday

 11-28-1997 #112300

 Z
 SMITH
GS 6
 26.68
NS 3
 18.00
NS 3
 18.48
 HASH TL 0
 0.00
 TOTAL
 4CU 18.48
 CASH ID -2.52
 CHECK ID 1
 10.00
 Chg ID 0
 0.00
 MISC ID 0
 0.00
 CPN ID 0
 0.00
 FSID 2
 11.00
 NEG1 8.20
 NEG2 0.00
 PO 0.00
 TAX 0.48
 0002Z

 0258 20:22TM

{ X: Daily Read
 { Z: Daily Reset

Report Type Symbol
 Cashier Name
 Gross Sales: Item Count
 Amount
 Net Sales without Tax (*Initial Status: Non-print*): Item Count
 Amount
 Net Sales with Tax (*Initial Status: Print*): Item Count
 Amount
 Other Income Department Sales (*Initial Status: Non-print*): Item Count
 Amount
 Total Customer Count, All Media Sales Amount
 Cash-in-drawer Amount
 Check-in-drawer: Count
 Amount (*Initial Status: Print*)
 Charge-in-drawer: Count
 Amount (*Initial Status: Non-print*)
 Miscellaneous Media-in-drawer: Count
 Amount (*Initial Status: Print*)
 Media-coupon-in-drawer: Count
 Amount (*Initial Status: Print*)
 Food Stamp-in-drawer: Count
 Amount (*Print for the Food Stamp feature*)
 NEG 1 Data
 NEG 2 Data
 Paid Out Amount
 Tax Amount (*Initial Status: Non-print*)
 Reset Count of this Reset Report (printed on Reset Reports only)

 Receipt Consecutive No., Current Time

Periodical Cashier Read or Reset Report

```

TEC STORE
1343 PEACH DRIVE
PHONE: 87-6437

Open 8:00am to 7:00pm
Closed: every Wednesday

11-28-1997    #112300

      ZO4

JONES
GS           179
             627.52
NS           139
             495.72
NS           139
             531.12
HASH TL      3
             1200.00
TOTAL
56CU        1726.92
NEG1         96.40
NEG2         4.20
PO           6.50
TAX          35.40

SMITH
GS           6
             26.68
NS           3
             18.00
NS           3
             18.48
HASH TL      0
             0.00
TOTAL
4CU         18.48
NEG1         8.20
NEG2         0.00
PO           0.00
TAX          0.48
3CL
4CL
5CL
6CL
7CL
8CL
0002Z
    
```

X04: Periodical All Cashier Read
Z04: Periodical All Cashier Reset

Report Type Symbol

Sales Data by Cashier 1 (JONES)
(format same as in Daily Report)

Sales Data by Cashier 2 (SMITH)

When a cashier has no sales data, only cashier No.
(or name if programmed) will be printed.

Reset Count of this Reset Report (printed on Reset Reports only)

Receipt Consecutive No., Current Time

4. Changing the Programmed Data

This chapter is provided for the store programmer or the store manager who may have to change the programmed data of the MA-1350-1 series ECR on a daily, weekly, or monthly basis. Usually, all the basic program data required for your store should be set before delivering the product by your local TOSHIBA TEC representative. However, to change or add program data, please refer to this chapter. It is also recommended to read other chapters in this manual in order to thoroughly understand the descriptions in this chapter. If there are any unclear points or program data other than listed here that must be changed or added, please contact your TOSHIBA TEC representative.

Character Entries for Programming Operations:

There are two methods of operations for character settings for names or messages: CHARACTER CODE ENTRY Method and DIRECT CHARACTER ENTRY Method.

CHARACTER CODE ENTRY Method:

This method is to set a character by entering a Character Code and depressing the [#NS] key. This method is allowed on the ECR keyboard.

DIRECT CHARACTER ENTRY Method:

This method is to set a character by directly depressing the Character Key on the following keyboards.

- ECR Normal Keyboard (Setting operations including character entries can be performed after the key operation "81 [@/FOR].)
- ECR Flat Keyboard using the "SET Mode Key Layout" sheet
- PK-2 Keyboard (PLU Keyboard; hardware option)

By using those character keys, the characters are directly entered. In this manual, sample operations are attached to most of the programming operations. And at name or message programming portions, characters are entered by the CHARACTER CODE ENTRY method. Instead of this, you may depress the Character Keys. For example, instead of entering 11[#NS] (to enter character "A"), you may simply depress Character Key "A" on any of three keyboards above.

On the following pages, Character Code Tables under the CHARACTER CODE ENTRY Method and the three different Keyboards under the DIRECT CHARACTER ENTRY Method are shown. These pages are to be referred to, every time the "Character Entries" sequence is contained in various programming operations in this manual.

Character Code Entry Method:

CHARACTER CODE Table:

Column Code →

Row Code ↓

	0	1	2	3	4	5	6	7	8	9	10	11	12	13	14	15	16	17	18
0	0	@	J	T	<	Ä	ì	↓	No	'	,		j	t		ä	â	(Ψ
1	1	A	K	U	>	Ë	Ø	↑	×	”	.	a	k	u		ö	ê)	Ω
2	2	B	L	V	{	Ö	ø	$\frac{1}{2}$	▽		:	b	l	v	Ü	ü	Ç	Γ	
3	3	C	M	W		É	÷	$\frac{1}{4}$	△		'	c	m	w	Æ	æ	é	Δ	
4	4	D	N	X	}	ë	\	★	☐		/	d	n	x	Œ	œ	è	Θ	
5	5	E	O	Y	~	ï		◇	;		#	e	o	y	Å	å	ú	Λ	
6	6	F	P	Z	☒	î		kg	^		*	f	p	z	Ñ	ñ	á	Ξ	
7	7	G	Q	\$	Γ	ô	—	lb	—		Π	g	q	+	%	β	í	Π	
8	8	H	R	£	J	û	→	[`		&	h	r	ø		Đ	ó	Σ	
9	9	I	S	¥	+	à	←	[°	-	!	i	s	=	?	ð			Φ

↑
Space

Example) Character code "12" is assigned to character "B".
Character code "120" is assigned to character "j".

Character Setting Operations

- To set a regular-sized character, enter the COL (column) code and then the ROW code, followed by the **[/NS]** key.

Example) To set "B", enter 12 and depress **[/NS]**.
To set "j", enter 120 and depress **[/NS]**.

- To set a blank instead of a character, enter 169 and depress **[/NS]**.
- Depress the **[@/FOR]** key once prior to a regular-sized character entry, and it will be a double-sized character (a blank will also be double-sized).

Example) To set "GROUP", "G" in double-sized, and "ROUP" in regular-sized:

[@/FOR] 17 [/#NS] 28 [/#NS] 25 [/#NS] 31 [/#NS] 26 [/#NS]
G R O U P

- Depress the **[@/FOR]** key twice prior to the first character code entry to set the entire message line or enter name with all double-sized characters.

Example) To set "GROUP" all in double-sized:

[@/FOR] [/@/FOR] 17 [/#NS] 28 [/#NS] 25 [/#NS] 31 [/#NS] 26 [/#NS]
G R O U P

All Double-sized Declaration

Direct Character Entry Method:

Using the ECR Normal Keyboard:

Keyboard layout can be changed as shown below by the key operation "81 **[@/FOR]**" before you enter the following setting operations.

- Store Message and Commercial Message Programming
- Cashier Name Programming
- Department Status Programming
- PLU Table Setting, Changing, or Deletion

Character Keys; A to Z

	LOG RECEIPT	DP#		RF	JF						
	#			C							A
Character Keys; • Space • / • - • ,	,	ITEM CORR		7	8	9	B	G	L	Q	V
	-	@/FOR		4	5	6	C	H	M	R	W
	SPACE	/		1	2	3	D	I	N	S	X
				0	00	.	E	J	O	T	Y
		PLU					ST	AT / TL		Z	

Characters shown above can be directly entered by depressing the corresponding Character Keys.

* Keyboard layout above in actual size is attached on the last page as appendix. Make a copy and use it when you perform programming operations executable by this keyboard layout.

- NOTES:**
1. Numeric keys are used to enter PLU Codes or numeric values of program data, etc. but not to enter the numerics as characters.
 2. Characters not shown on the keyboard on the preceding page can be entered by the Character Code Entry Method.
 3. After setting operation on this keyboard is completed, operate "82 [@/FOR]" to regain the keyboard layout for registrations.
To indicate that the keyboard layout has been changed, the following receipts are issued after the key operation "81 [@/FOR]" or "82 [@/FOR]".

Receipt issued by the key operation "81 [@/FOR]"

Receipt issued by the key operation "82 [@/FOR]"

```

TEC STORE
1343 PEACH DRIVE
PHONE: 87-6437

Open 8:00am to 7:00pm
Closed: every Wednesday

11-28-1997      #112300

* P K B O N *

0312 21:31TM
    
```

```

TEC STORE
1343 PEACH DRIVE
PHONE: 87-6437

Open 8:00am to 7:00pm
Closed: every Wednesday

11-28-1997      #112300

* P K B O F F *

0313 21:32TM
    
```

Using the ECR Flat Keyboard:

Use the "SET Mode Key Layout" sheet when you perform the following setting operations

- Store Message and Commercial Message Programming
- Cashier Name Programming
- PLU Table Setting, Changing, or Deletion

Character Keys

!	@	#	\$	%	¢	&	★	()	LOG RECEIPT	DP#	ITEM CORR		RF	JF
q	w	e	r	t	y	u	i	o	p						
a	s	d	f	g	h	j	k	l	"		C		@/FOR		
z	x	c	v	b	n	m			'	#	7	8	9		
Q	W	E	R	T	Y	U	I	O	P		4	5	6		
A	S	D	F	G	H	J	K	L	;	PLU	1	2	3	ST	
Z	X	C	V	B	N	M	SPACE	.	/		0	00	.	AT / TL	

Characters shown above can be directly entered by depressing the corresponding Character Keys.

- NOTES:**
1. Numeric keys are used to enter PLU Codes or numeric values of program data, etc. but not to enter the numerics as characters.
 2. Characters not shown on the keyboard on the preceding page can be entered by the Character Code Entry Method.

Using the PK-2 (PLU Keyboard; hardware option):

The PK-2 (hardware option PLU Keyboard) is used to enter the required PLU Code by simply depress the PLU Preset-code Key on the PK-2 keyboard in the “REG”, “MGR”, or “ □ ” mode. In addition, the PK-2 can be used to enter characters directly during the programming operations that require character settings, such as Store Message and Commercial Message Programming, PLU Table Setting, Changing, or Deletion, etc.

The figure below shows the key indications of the PK-2 keyboard. (A sheet of these character indications is attached to the PK-2 unit. Insert it between the film layers that cover the PK-2 keyboard for using the keyboard for this purpose.)

Instead of entering a 2- or 3- digit character code and depressing the [#/NS] key on the ECR keyboard, a simple depression of the appropriate key on the PK-2 keyboard will be the character entry.

All the function keys, such as [@/FOR], [ST], [#/NS], [AT/TL], etc. must be operated on the ECR side. Any characters not listed on the template may be entered by the Character Code Entry method on the ECR keyboard (the characters even listed on the template may be entered as well by that method).

Please note also that the keys “0” to “9” in the figure below function as character keys but do not function for code entries. Any code entries, for Item Codes, Address Nos, etc. must be entered through the Numeric Keys on the ECR keyboard.

The One Double-size Declaration (by depressing the [@/FOR] key once prior to the required character) and the All Double-sized Declaration (by depressing [@/FOR] twice before all the characters) are the same as in the Character Code Entry method.

1	11	21	31	41	51	61	71	81	91	7	8	9
2	12	22	32	42	52	62	72	82	92	4	5	6
3	13	23	33	43	53	63	73	83	93	1	2	3
!	@	#	\$	%		&	*	()		0	
4	14	24	34	44	54	64	74	84	94	104	114	124
q	w	e	r	t	y	u	i	o	p			
5	15	25	35	45	55	65	75	85	95	105	115	125
a	s	d	f	g	h	j	k	l			+	
6	16	26	36	46	56	66	76	86	96	106	116	126
z	x	c	v	b	n	m			,	-	=	
7	17	27	37	47	57	67	77	87	97	107	117	127
Q	W	E	R	T	Y	U	I	O	P	[]	
8	18	28	38	48	58	68	78	88	98	108	118	128
A	S	D	F	G	H	J	K	L		:		
9	19	29	39	49	59	69	79	89	99	109	, 119	129
Z	X	C	V	B	N	M	SPACE	.	/	?		
10	20	30	40	50	60	70	80	90	100	110	120	130

Condition for Programming Operations:

At the top of each programming operation sequence in this chapter, "**Condition**" is attached. Unless the register satisfies this condition, the programming operations will not be allowed.

When Condition "**After ... Reset**" is attached:

"After ... Reset" means that the designated reset report must be taken before entering the programming (setting) operation. An error will result if the operation is attempted without taking the report.

However, it does not necessarily mean "immediately after ..." When the designated reset report has already been taken and then some operations are performed in the "X", "Z", or "SET" mode, the condition "After ... Reset" is still satisfied and the programming operation is still allowed.

On the contrary, when the designated reset report has been taken but then some sales data relating to that report's output data are entered in the "REG", "MGR" or "☐" mode, the programming operation will no longer be allowed and the same reset report must be taken again.

Thus, the condition "After ... Reset" indicates that all the sales data relating to the report data must be zero (except non-resettable memory data). Because of this "Condition" requirement, the report data will be protected from any inconsistencies of sales data entered in the period from a resetting of the report to another resetting of the same report next time.

When **Condition** "Any time outside a sale" is attached:

It means that no condition is specified to a programming (setting) operation, and that the operation is allowed any time outside a sale (but the cashier must be signed off if the Cashier Signing Method option is selected).

Before changing each setting described in the following pages, be sure to turn the Control Lock to the **SET** position using the **MA** Key.

Store Message and Commercial Message Programming

Condition: Any time outside a sale

Programming Procedure:

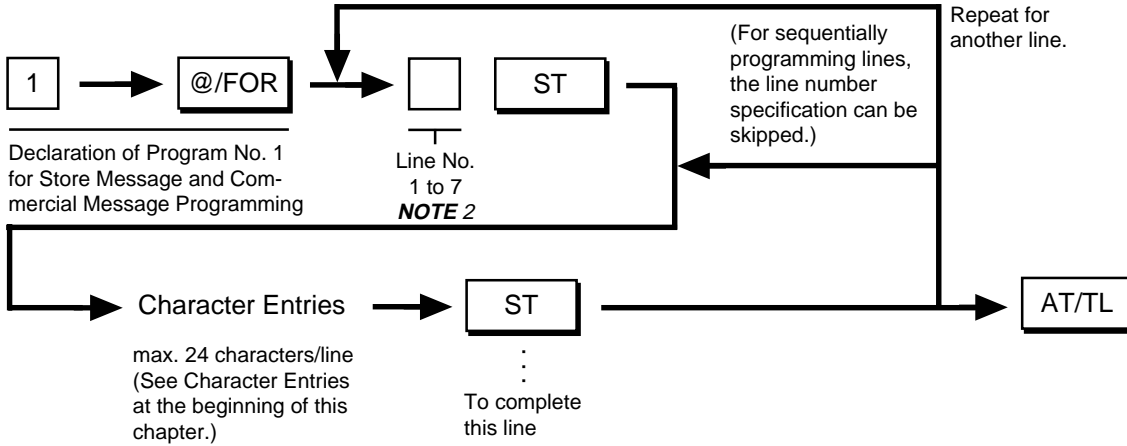

- NOTES:**
1. For each line, a maximum of 24 regular-sized characters or 12 double-sized characters may be entered. A combination of both types is also available.
 2. The line Nos. available are as follows.
 - Store Stamp Feature (Initial status)
Line Nos. for Commercial Message (1 to 3)
 - Store Message Print Feature
Line Nos. for Store Message (1 to 4)
Line Nos. for Commercial Message (5 to 7)
 3. If any incorrect characters have been programmed, depress the [C] key to clear all the characters on a line and then re-enter characters from the beginning, or end the line with an [ST] and re-program the entire line. The new data will be active.
 4. When all the lines have been programmed, do a check by issuing a receipt. Only the lines with errors need to be re-programmed; other lines will not be affected.
 5. When blanks are programmed for the whole one line, it will cause one line space.
 6. As for Commercial Message, if blanks are programmed for all three lines, it will cause line feed. However, if the message is programmed for one line, remaining two lines will result in two lines space.
As for the Store Message Print Feature, even if blanks are programmed for all four lines assigned to Store Message, it will not cause line feed. Those lines will result in four lines space.

Example) To program the following Store Message and Commercial Message (under the Store Message Print Feature):

T E C S T O R E	Line No. 1
1 3 4 3 P E A C H D R I V E	Line No. 2
P H O N E : 8 7 - 6 4 3 7	Line No. 3
	Line No. 4
O p e n 8 : 0 0 a m t o 7 : 0 0 p m	Line No. 5
C l o s e d : e v e r y W e d n e s d a y	Line No. 6
	Line No. 7

Store Message and Commercial Message Programming Receipt Format:

Key Operation: Control Lock: **SET**

1 @/FOR

1 ST (Line No. 1)
 1 6 9 #/NS (space)
 1 6 9 #/NS (space)
 1 6 9 #/NS (space)
 @/FOR 3 0 #/NS (T)
 @/FOR 1 5 #/NS (E)
 @/FOR 1 3 #/NS (C)
 1 6 9 #/NS (space)
 1 6 9 #/NS (space)
 @/FOR 2 9 #/NS (S)
 @/FOR 3 0 #/NS (T)
 @/FOR 2 5 #/NS (O)
 @/FOR 2 8 #/NS (R)
 @/FOR 1 5 #/NS (E)
 ST (to complete Line 1)

(2 ST) (Line No. 2)
 1 6 9 #/NS (space)
 1 6 9 #/NS (space)
 1 6 9 #/NS (space)
 1 6 9 #/NS (space)
 0 1 #/NS (1)
 0 3 #/NS (3)
 0 4 #/NS (4)
 0 3 #/NS (3)
 1 6 9 #/NS (space)
 2 6 #/NS (P)
 1 5 #/NS (E)
 1 1 #/NS (A)
 1 3 #/NS (C)

1 8 #/NS (H)
 1 6 9 #/NS (space)
 1 4 #/NS (D)
 2 8 #/NS (R)
 1 9 #/NS (I)
 3 2 #/NS (V)
 1 5 #/NS (E)
 ST (to complete Line 2)

(3 ST) (Line No. 3)
 1 6 9 #/NS (space)
 1 6 9 #/NS (space)
 1 6 9 #/NS (space)
 1 6 9 #/NS (space)
 1 6 9 #/NS (space)
 1 6 9 #/NS (space)
 2 6 #/NS (P)
 1 8 #/NS (H)
 2 5 #/NS (O)
 2 4 #/NS (N)
 1 5 #/NS (E)
 1 0 2 #/NS (:)
 1 6 9 #/NS (space)
 0 8 #/NS (8)
 0 7 #/NS (7)
 9 9 #/NS (-)
 0 6 #/NS (6)
 0 4 #/NS (4)
 0 3 #/NS (3)
 0 7 #/NS (7)
 ST (to complete Line 3)

11-28-1997 #0
 PO1
 1 TEC STORE
 2
 3 1343 PEACH DRIVE
 5 PHONE: 87-6437
 6 Open 8:00am to 7:00pm
 Closed: every Wednesday
 0018 11:55TM

5 ST (Line No. 5)
2 5 #/NS (O)
1 2 6 #/NS (p)
1 1 5 #/NS (e)
1 2 4 #/NS (n)
1 6 9 #/NS (space)
1 6 9 #/NS (space)
0 8 #/NS (8)
1 0 2 #/NS (:)
0 0 #/NS (0)
0 0 #/NS (0)
1 1 1 #/NS (a)
1 2 3 #/NS (m)
1 6 9 #/NS (space)
1 3 0 #/NS (t)
1 2 5 #/NS (o)
1 6 9 #/NS (space)
0 7 #/NS (7)
1 0 2 #/NS (:)
0 0 #/NS (0)
0 0 #/NS (0)
1 2 6 #/NS (p)
1 2 3 #/NS (m)
ST (to complete Line 5)

(6 ST) (Line No. 6)
1 3 #/NS (C)
1 2 2 #/NS (l)
1 2 5 #/NS (o)
1 2 9 #/NS (s)
1 1 5 #/NS (e)
1 1 4 #/NS (d)
1 0 2 #/NS (:)
1 6 9 #/NS (space)
1 1 5 #/NS (e)
1 3 2 #/NS (v)
1 1 5 #/NS (e)
1 2 8 #/NS (r)
1 3 5 #/NS (y)
1 6 9 #/NS (space)
3 3 #/NS (W)
1 1 5 #/NS (e)
1 1 4 #/NS (d)
1 2 4 #/NS (n)
1 1 5 #/NS (e)
1 2 9 #/NS (s)
1 1 4 #/NS (d)
1 1 1 #/NS (a)
1 3 5 #/NS (y)
ST (to complete Line 6)

AT/TL

Cashier Name Programming

Condition: Any time outside a sale

Programming Procedure:

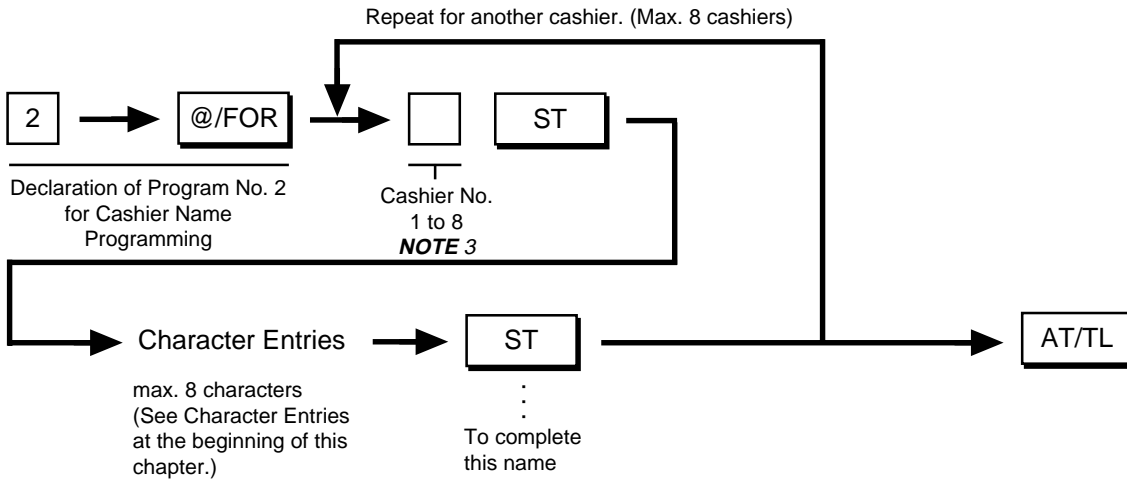

- NOTES:**
1. For each cashier name, a maximum of 8 regular-sized characters or 4 double-sized characters may be entered. A combination of both types is also available.
 2. This programming is available only when the cashier identifying operation option has been selected.
 3. Number of the controllable cashiers differs as follows.
 - Max. 4 cashiers for the Push LED Cashier Key and the Barrel Lock
 - Max. 8 cashiers for the Cashier Signing and the [CLK] Key

Cashier Name Programming Receipt Format:

Key Operation: Control Lock: SET

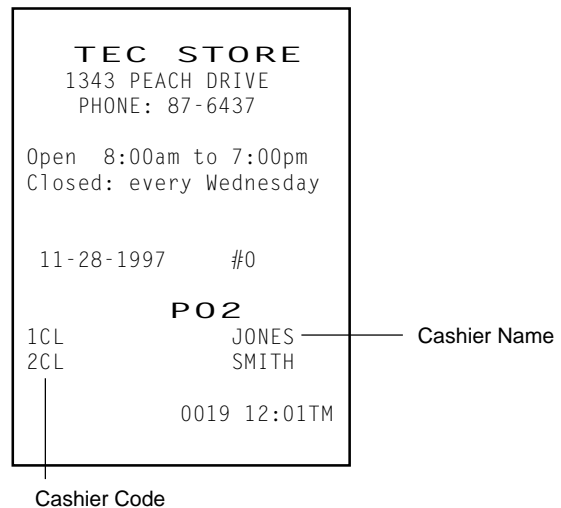
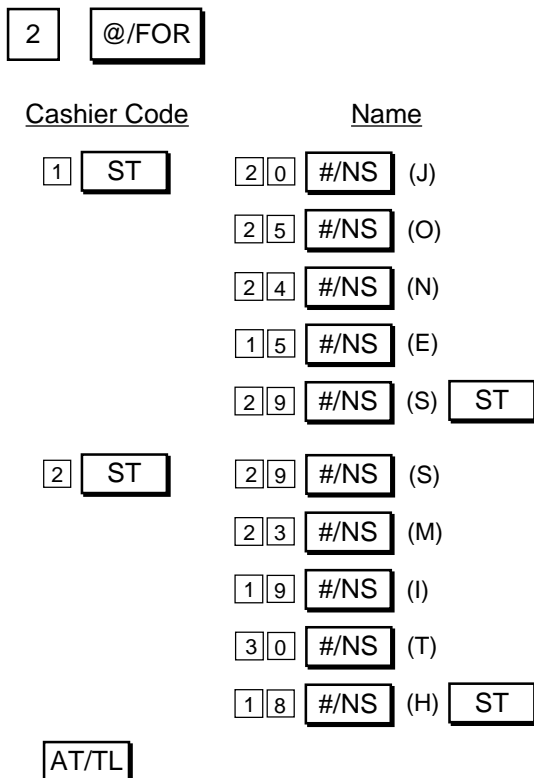

Department Status Programming

Condition: After Daily Financial Reset and Periodical Financial Reset (and All PLU Reset if the positive/negative status is to be changed)
When the program option "Department Report separately issued from Financial Report" has been selected: To add to the above conditions, After Daily Department Reset and Periodical Department Reset

Programming Procedure:

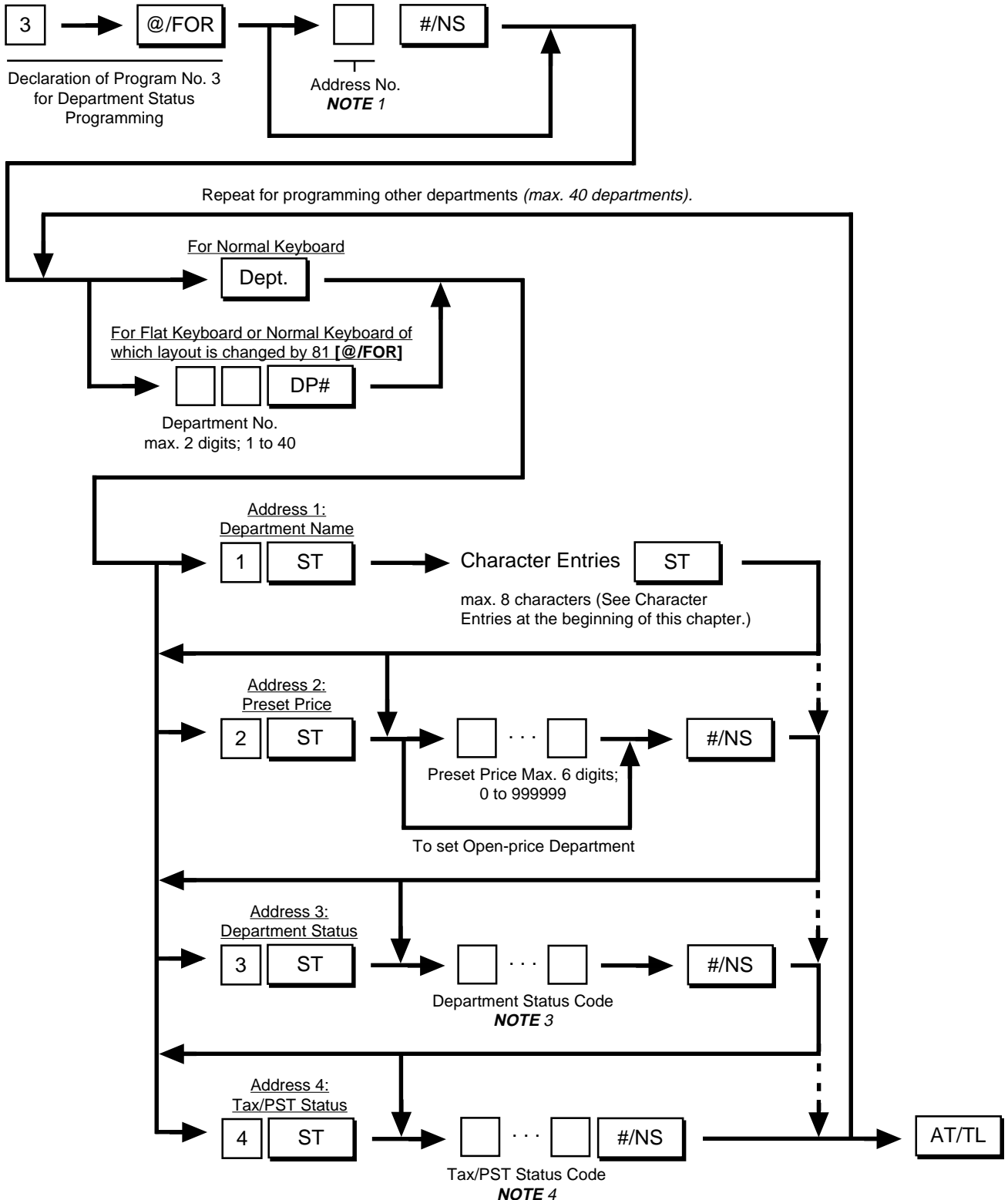

- NOTES:**
1. "Address No." designation located after the key operation "3 [@/FOR]" can be omitted if unnecessary. When an address No. is designated, the programming of the designated address will be automatically repeated for multiple departments.
 2. For each department name, a maximum of 8 regular-sized characters or 4 double-sized characters may be entered. A combination of both types is also available.
 3. Department status available is as follows.

Status Code	Contents	Not select	Select
1	Single-item	Itemized	Single-item
2	Negative Status	Positive Status	Negative Status
3	Other Income Dept.	Ordinary Dept.	Other Income Dept.
4	Food Stamp/GST Status	Without	With

- When you select the status codes 1 and 2, enter 12, then depress the [#NS] key.
 - When you select none of the status shown above, enter 0, then depress the [#NS] key.
4. As for Tax/PST code, more than one code can be entered for combining Tax/PST 1 to 3.
 - When you select Tax/PST 1 and 3 as "Taxable", enter 13, then depress the [#NS] key.

However, ask your TOSHIBA TEC representative for further details of the Tax/PST Status Setting, because its setting directly affects sales data of your store.

Department Status Program Receipt Format:

Key Operation: Control Lock: **SET**

[3] [@/FOR]

[Dept.1]
 [1] [ST]
 [2] [3] [#/NS] (M)
 [1] [5] [#/NS] (E)
 [1] [1] [#/NS] (A)
 [3] [0] [#/NS] (T)
 [ST]
 ([2] [ST])
 [5] [0] [0] [#/NS]
 ([3] [ST])
 [4] [#/NS]
 ([4] [ST])
 [1] [#/NS]
 ⋮

[Dept.5]
 [3] [ST]
 [1] [2] [#/NS]
 [Dept.6]
 [3] [ST]
 [3] [#/NS]
 [AT/TL]
 Tax/PST Status
 1: Tax/PST 1 taxable
 2: Tax/PST 2 taxable
 3: Tax/PST 1 & Tax/PST 2 taxable
 4: Tax/PST 3 taxable
 5: Tax/PST 1 & Tax/PST 3 taxable
 6: Tax/PST 2 & Tax/PST 3 taxable
 7: Tax/PST 1 & Tax/PST 2 & Tax/PST 3 taxable
 0: Non-taxable

```

TEC STORE
1343 PEACH DRIVE
PHONE: 87-6437

Open 8:00am to 7:00pm
Closed: every Wednesday

11-28-1997 #0

PO3

01 DP01
#01 MEAT 5.00@
#02
#03 00 F
#04 01
02 DP02
#01 FISH 00 F
#03 02
#04 02
03 DP03
#01 DRINK 03
#04
04 DP04
#01 BAKERY 01
#04
05 DP05
#03 10
06 DP06
#03 40

0028 13:03TM
    
```

Department Name
 Preset Price
 Food Stamp Status
 or GST Status
 F: Food Stampable
 T: GST Taxable
 Positive/Negative
 Status
 -: Negative
 Blank: Positive

Department
 Status
 0: Itemized
 1: Single-item
 4: Other Income
 5: Other Income
 (Single-item)

PLU Table Setting, Changing, or Deletion

Setting or Changing PLUs:

Condition: *To change settings of a PLU:* When the required PLU sales total memory is zero (i.e. when no sales are made or after a PLU Reset Report is taken to reset the sales data of the PLU into zero)

To add new PLUs or to change PLU Name only: Any time outside a sale

Programming Procedure:

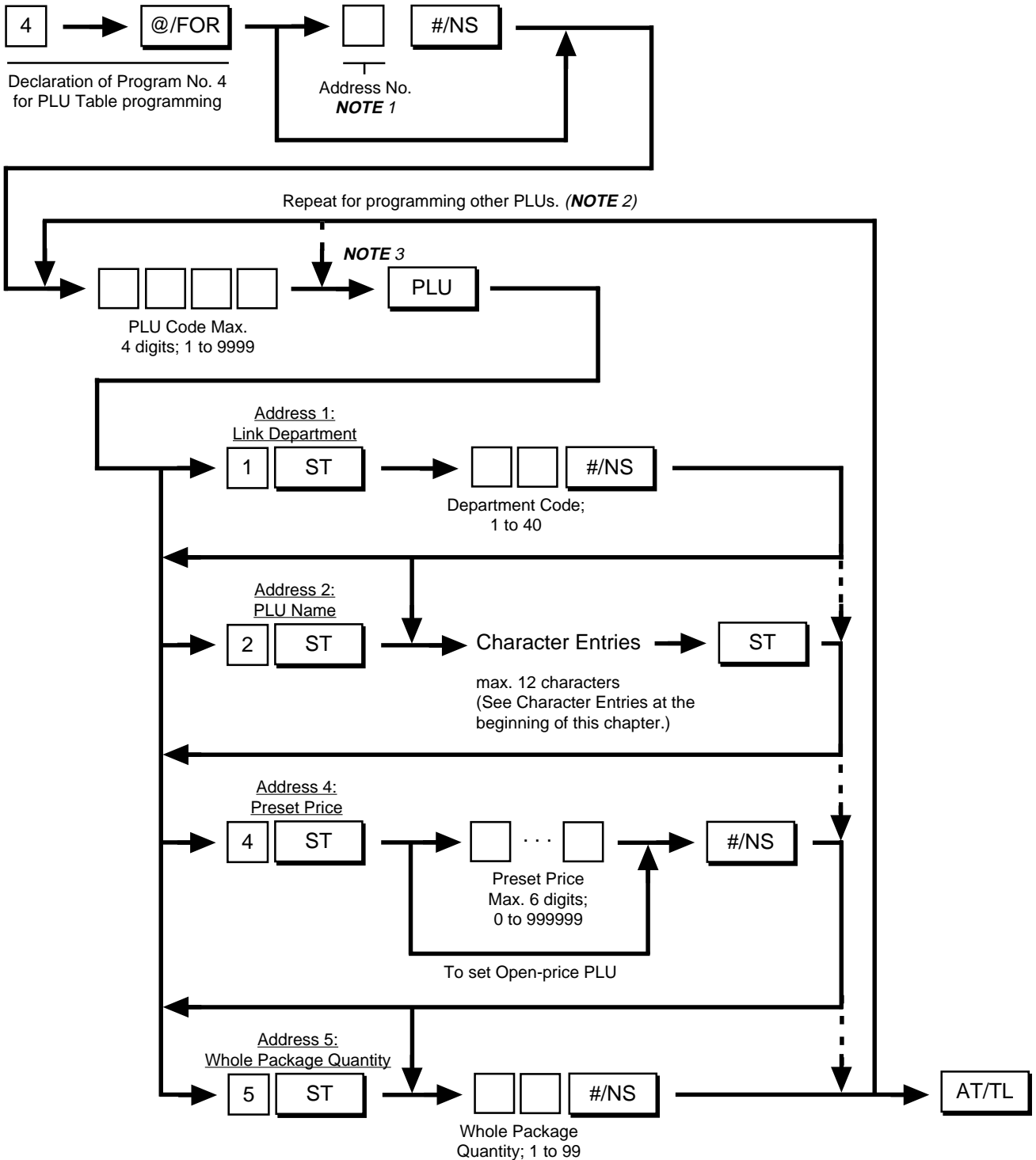

Deleting individual PLUs:

Condition: When the required PLU sales total memory is zero (i.e. when no sales are made or after a PLU Reset Report is taken to reset the sales data of the PLU into zero)

Deleting Procedure:

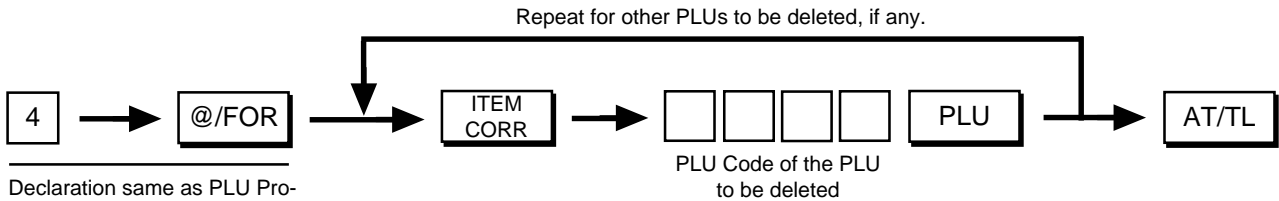

Declaration same as PLU Programming on the preceding pages.

- NOTES:**
1. Deletions are possible PLU by PLU.
 2. If all the PLUs must be deleted (i.e. the PLU system itself is not necessary), close the **[PLU]** Key. (Ask your TOSHIBA TEC representative.)

PLU Deletion Receipt Format:

Key Operation: Control Lock: **SET**

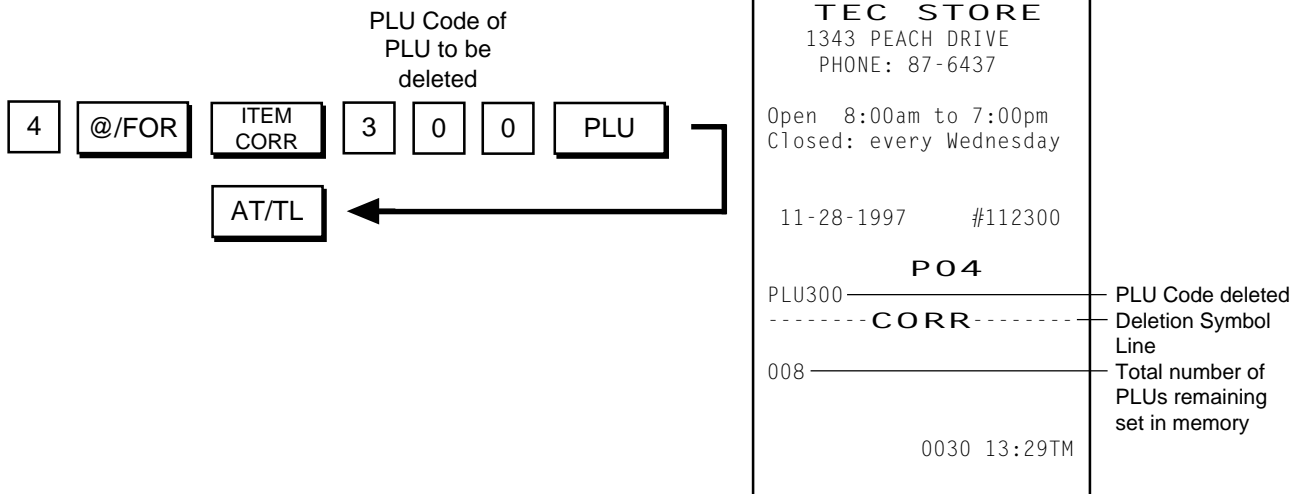

Time Setting or Adjustment

Condition for Setting: Any time outside a sale

Setting Procedure:

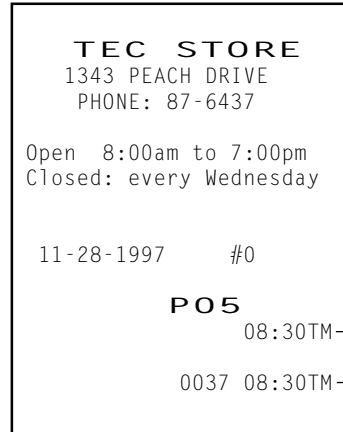
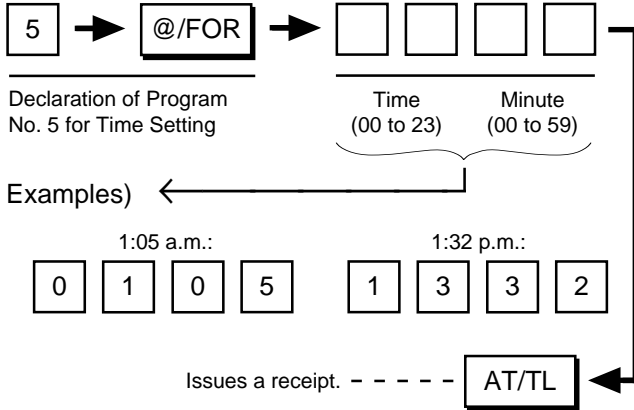

Date Setting or Adjustment

Condition for Setting: Any time outside a sale

Setting Procedure:

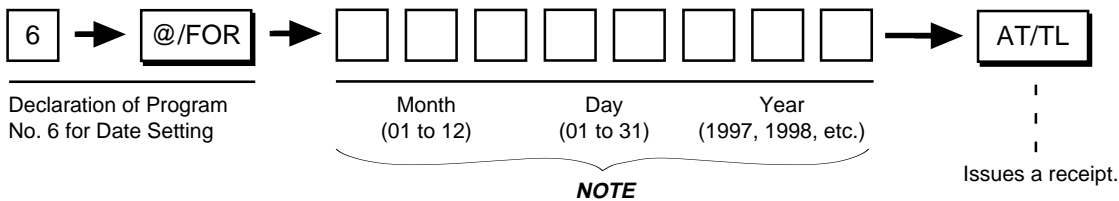

NOTE: To set 15 December 1997, any one of the following three orders can be selected:
12151997 (Month-Day-Year order, Default setting)
15121997 (Day-Month-Year order)
19971215 (Year-Month-Day order)
 If you want to change the order into Day-Month-Year or Year-Month-Day, ask your TOSHIBA TEC representative.

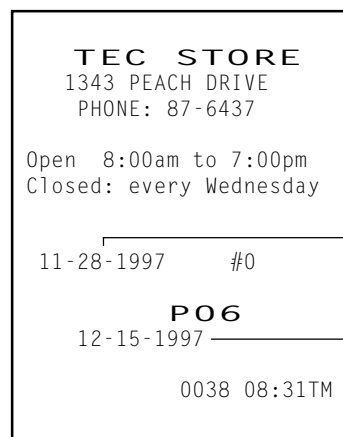

PLU Preset-code Key Setting

When there are any keys programmed as PLU Preset-code Keys on the ECR Keyboard, and/or when the PLU Keyboard PK-2 (hardware option) is connected to the ECR, a PLU code may be preset to each of those keys in this operation.

Condition: Any time outside a sale

Programming Procedure:

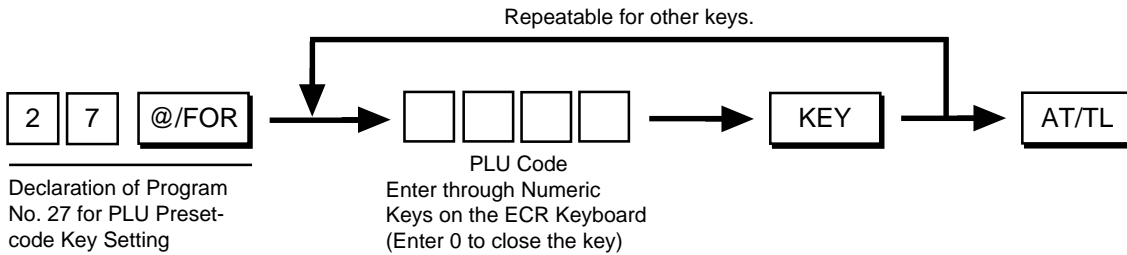

- NOTES:**
1. If the PLU Code entry is skipped and a **[KEY]** is simply depressed in the above sequence, the preprogrammed PLU Code of the KEY will be displayed.
 2. If "0" is entered as PLU Code in the above sequence, the KEY will be closed. Pressing the closed KEY in sale entry will cause an error.

PLU Preset-code Key Program Receipt Format:

Key Operation: Control Lock: **SET**

2 7 @/FOR

5 0 0 Required Key AT/TL

PLU Code

Location Code (left side); refer to REMARKS 1 and 2 on the next page. PLU Code assigned to the key (right side)

TEC STORE	
1343 PEACH DRIVE PHONE: 87-6437	
Open 8:00am to 7:00pm Closed: every Wednesday	
11-28-1997	#0
P 27	
#116	0500
0089 12:11TM	

PK-2 KEYBOARD

1	11	21	31	41	51	61	71	81	91	101	111	121
2	12	22	32	42	52	62	72	82	92	102	112	122
3	13	23	33	43	53	63	73	83	93	103	113	123
4	14	24	34	44	54	64	74	84	94	104	114	124
5	15	25	35	45	55	65	75	85	95	105	115	125
6	16	26	36	46	56	66	76	86	96	106	116	126
7	17	27	37	47	57	67	77	87	97	107	117	127
8	18	28	38	48	58	68	78	88	98	108	118	128
9	19	29	39	49	59	69	79	89	99	109	119	129
10	20	30	40	50	60	70	80	90	100	110	120	130

- REMARKS:** 1. *The Nos. 1 through 130 marked on the PK-2 Keyboard are the KEY Nos. to be printed on the left side of the program receipt issued in the operation on the preceding page. If each KEY is not set with a PLU Code, the auto-preset PLU Code identical to the initial KEY No. in the above figure will be active as its preset PLU Code*
ex.) KEY No. 1 ... PLU Code 1
KEY No. 130 ... PLU Code 130
2. *When a PLU code is assigned to a PLU Preset-code Key on the ECR Keyboard in the operation on the preceding page, the Hardware Key Code which indicates the absolute location of the key will be printed to the left of the assigned PLU Code. Since it is hard to explain which location code corresponds to each key (due to an irregular numbering), it is suggested to verify the positioning by simply depressing the KEY and reading the code in the display (described in NOTE 1 on the preceding page). This reading operation is applied to the PK-2 Keyboard as well.*

Department Preset Price Setting or Changing

Condition: Any time outside a sale

Programming Procedure:

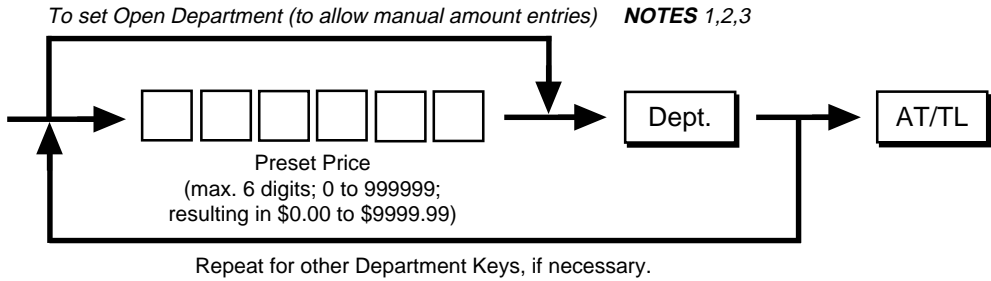

- NOTES:**
1. All the Department Keys are open departments (with no preset prices) as initial status.
 2. If a Department Key is pressed with no Preset Price entry, the key is set as an open-price Department Key.
 3. If "0" is entered as Preset Price, the Department Key is set with Preset Price of \$0.00.

Department Preset Price Setting Receipt Format:

Key Operation: Control Lock: **SET**



TEC STORE
1343 PEACH DRIVE
PHONE: 87-6437

Open 8:00am to 7:00pm
Closed: every Wednesday

11-28-1997 #0

POO

01 MEAT	7.00	Preset Price \$7.00 for Dept. 1 (MEAT)
0095 12:24TM		

PLU Preset Price Changing

When only changing preset prices of PLUs as part of daily requirements, this operation is quicker than operating “PLU Table Setting, Changing, or Deletion.”

Condition: Any time outside a sale

Programming Procedure:

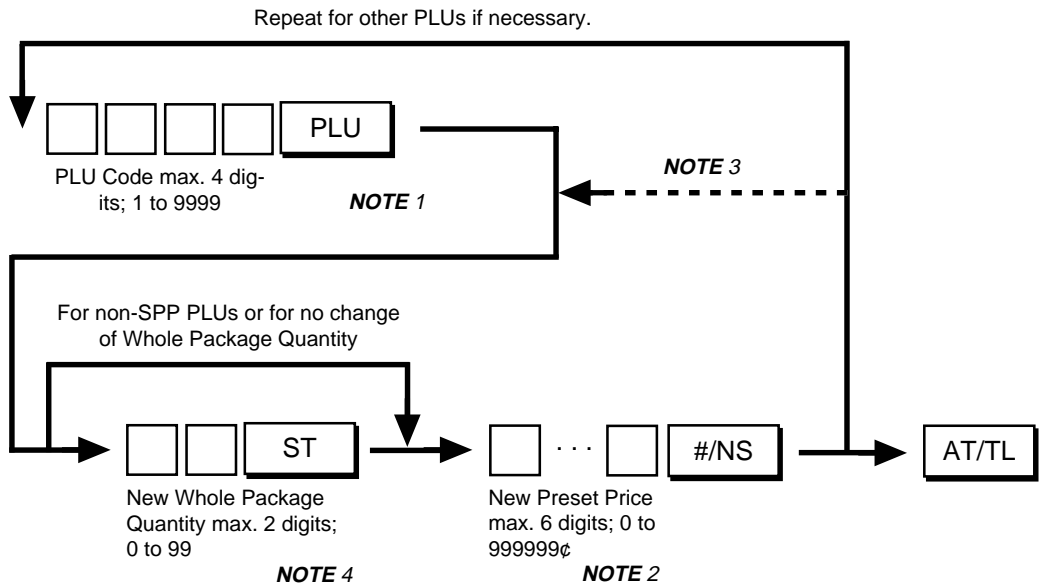

- NOTES:**
1. The PLU Codes must exist in the PLU table file already programmed.
 2. If “0” is entered as the New Preset Price, price of \$0.00 is set. Neither price setting nor Whole Package Quantity changing are possible for Open-price PLUs in this operation.
 3. For sequentially accessing PLU Codes, the code specification can be omitted.
 4. The entry of “New Whole Package Quantity” is possible only for SPP-type PLUs (those already set with Whole Package Quantity). When the Whole Package Quantity is changed here, the New Preset Price (i.e., New Whole Package Price) must also be set here.

PLU Preset Price Change using the PLU Preset-code Key:



PLU Price Change Setting Receipt Format

Key Operation: Control Lock: **SET**

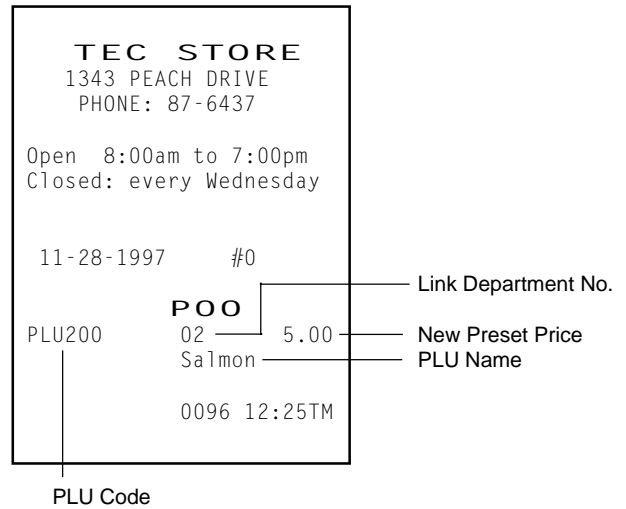
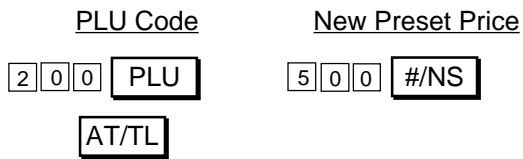

% Key Preset Rate Setting or Changing

Setting Preset Rate for % Keys

Condition: Any time outside a sale

Programming Procedure:

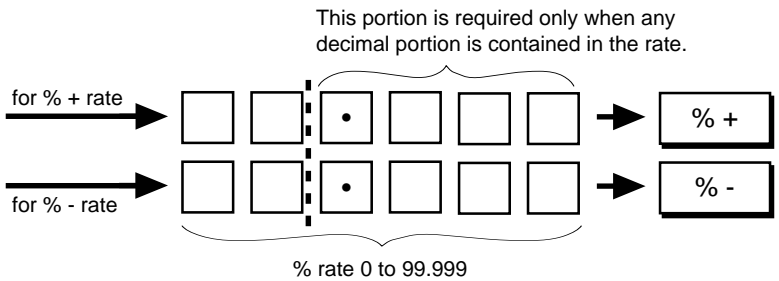

Examples)

7%: **7**, 12%: **12**, 8.55%: **8.55**, 12.345%: **12.345**
To reset the rate once set, enter "0". When "0" is set, the % key will always require a manual rate entry in sale transactions.

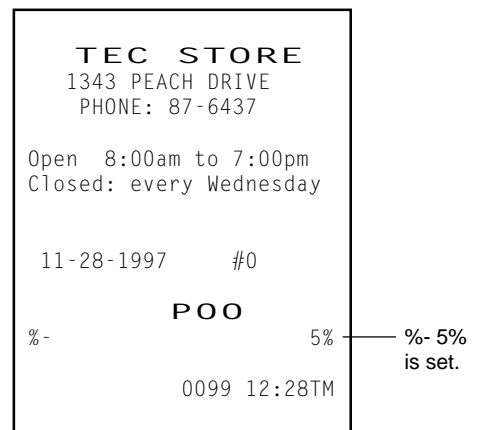
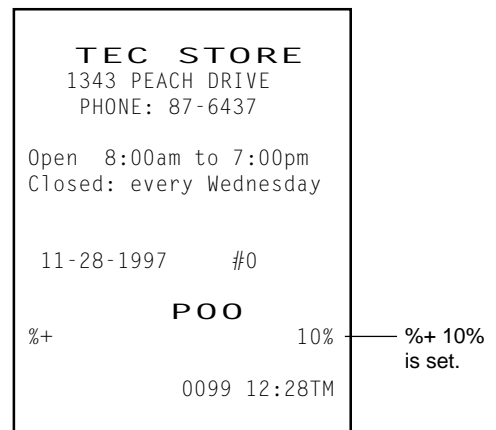

Register No. Setting

When multiple registers are used in one store, or to distinguish this register from others used by other stores in the same chain, set the Register Number in the following procedure.

Condition: Any time outside a sale

Programming Procedure:

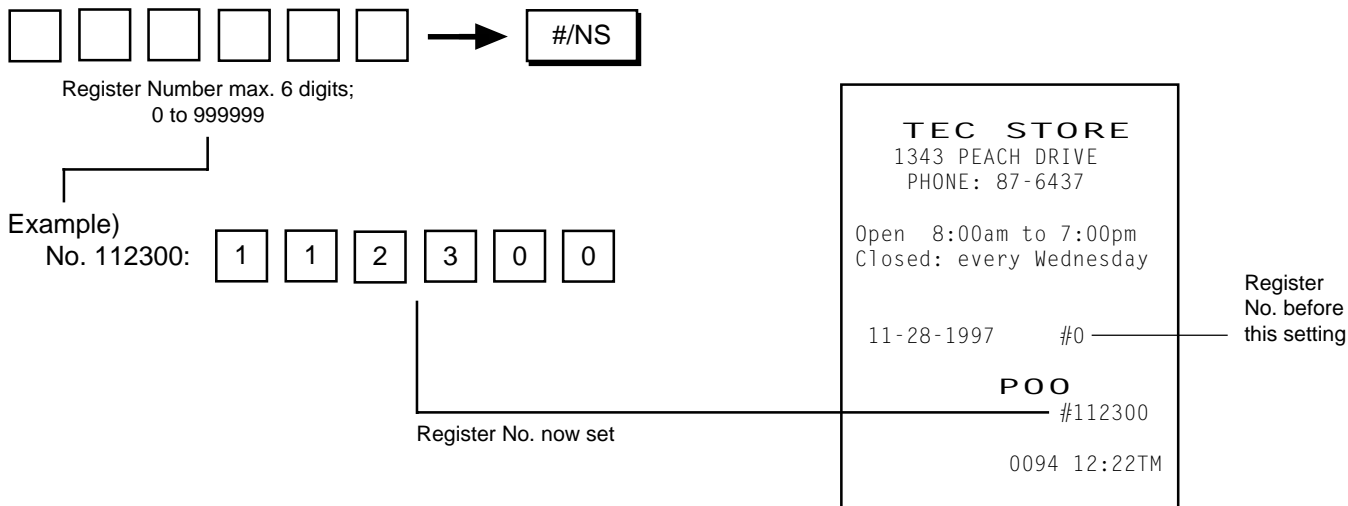

- NOTES:**
1. The Decimal Point cannot be entered in the Register Number.
 2. Preceding zeros, if any, will not be printed. For example, if "001234" is entered, "#1234" will be printed.

Foreign Currency Exchange Rate Setting

Condition: Any time outside a sale

Programming Procedure:

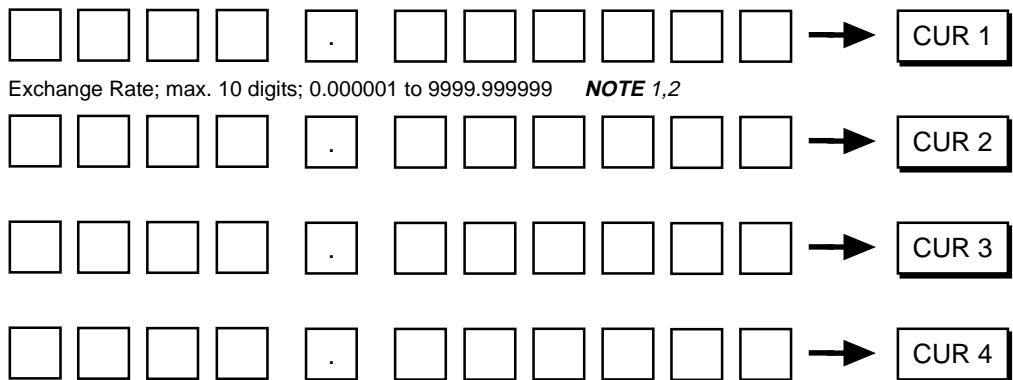

- NOTES:**
1. Obtain the rate by calculating in the subsidiary currency unit values for both the domestic and the foreign currency. (In case of calculating the rate from the domestic to a foreign currency with the same zero-suppress form, such as from US\$ to French Franc, it will be no problem. However, in case of exchanging from a domestic currency such as US\$ to a foreign currency such as Japanese yen, this rule must be obeyed; otherwise a wrong rate will result.)

2. Calculate the required foreign currency value equivalent to the domestic currency value "1". Then the obtained value is the Exchange Rate value to be entered in the setting operation above.

Example) Domestic Currency is US\$:
 1 cent = XXXX . XXXXXX centimes (French Franc)
 = XXXX . XXXXXX pfennigs (Deutsche Mark)
 = XXXX . XXXXXX yen (Japanese Yen)
 etc.
 Enter this value as the foreign currency exchange rate.

3. If "0" is set as the exchange rate, that key cannot be used in sale entries.

Example)

0.7143 for the [CUR 1] key:

[0] [.] [7] [1] [4] [3] [AT/TL]

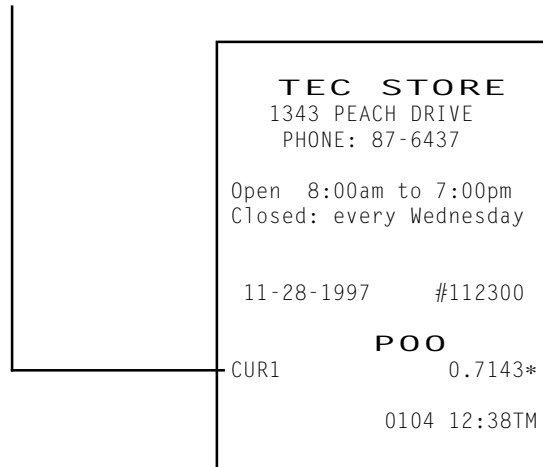

Listing Capacity Setting for Tender Media

Condition: After Financial Daily Reset

Programming Procedure:

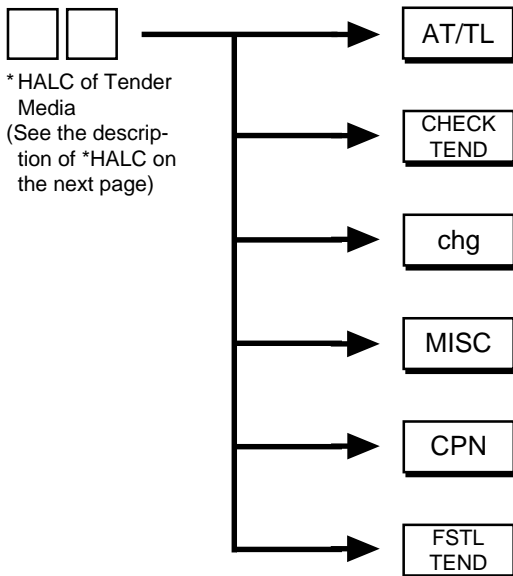

* HALC High Amount Listing Capacity (to be set in a 2-digits code)

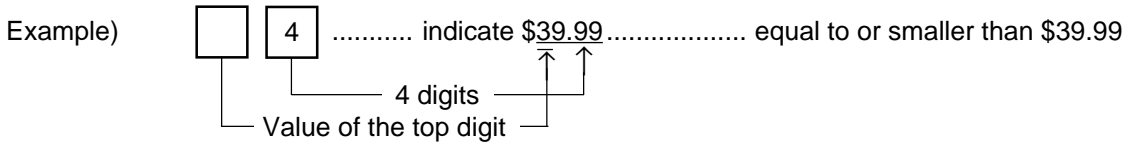

- NOTES:**
1. To reset an individual media listing capacity, enter 0 before media key depression in the above operation.
 2. The HALC of each tender media is effective only when the media key is used for tendering but not when it is used as Total key.
 3. The listing capacity is cleared in "MGR" mode. It cannot be cleared by the **[LC OPEN]** (or **[OPEN]**) key.

Example) To set the HALC (\$39.99) for the **[AT/TL]** key:

Key Operation: Control Lock: **SET**

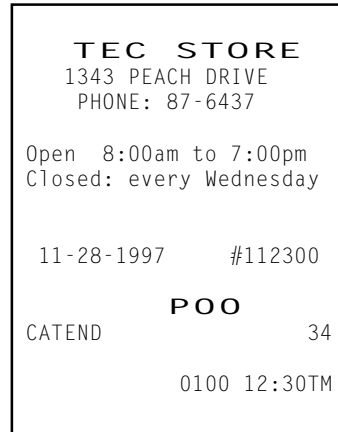

Vendor Coupon Limit Amount Setting

Condition: After Financial Daily Reset

Programming Procedure:

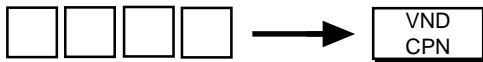

Limit Amount Max. 4
digits; 0 to 9999

- NOTES:**
1. To reset the vendor coupon limit amount, enter 0 before the **[VND CPN]** key depression in the above operation.
 2. The vendor coupon limit amount is cleared in "MGR" mode. It cannot be cleared by the **[LC OPEN]** (or **[OPEN]**) key.

Example) To set the limit amount (\$20.00) for the **[VND CPN]** key:

Key Operation: Control Lock: **SET**



PK-2 KEYBOARD

1	11	21	31	41	51	61	71	81	91	101	111	121
2	12	22	32	42	52	62	72	82	92	102	112	122
3	13	23	33	43	53	63	73	83	93	103	113	123
4	14	24	34	44	54	64	74	84	94	104	114	124
5	15	25	35	45	55	65	75	85	95	105	115	125
6	16	26	36	46	56	66	76	86	96	106	116	126
7	17	27	37	47	57	67	77	87	97	107	117	127
8	18	28	38	48	58	68	78	88	98	108	118	128
9	19	29	39	49	59	69	79	89	99	109	119	129
10	20	30	40	50	60	70	80	90	100	110	120	130

- REMARKS:** 1. *The Nos. 1 through 130 marked on the PK-2 Keyboard are the KEY Nos. to be printed on the left side of the program receipt issued in the operation on the preceding page. If each KEY is not set with a PLU Code, the auto-preset PLU Code identical to the initial KEY No. in the above figure will be active as its preset PLU Code*
ex.) KEY No. 1 ... PLU Code 1
KEY No. 130 ... PLU Code 130
2. *When a PLU code is assigned to a PLU Preset-code Key on the ECR Keyboard in the operation on the preceding page, the Hardware Key Code which indicates the absolute location of the key will be printed to the left of the assigned PLU Code. Since it is hard to explain which location code corresponds to each key (due to an irregular numbering), it is suggested to verify the positioning by simply depressing the KEY and reading the code in the display (described in NOTE 1 on the preceding page). This reading operation is applied to the PK-2 Keyboard as well.*

5. Program Data Verification



Whenever programming operations are performed, it is recommended to issue Program Verification receipts to check the programmed data before entering any other operation.

Operating Procedure

Condition: Any time outside a sale

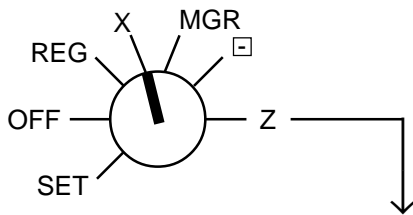
Operating Procedure:



"R OFF" Lamp  	Illuminated: Verification data is printed on journal only.	Reverse the status, if necessary, by depressing the [LOG/ RECEIPT] key. * The [RECEIPT ISSUE] key is not effective in X mode.
	Extinguished: Verification data is printed on both journal and receipt.	

		<i>Contents to be Printed for Verification</i>	<i>Format Page</i>
→	1	ST Department Preset Price Read: Preset Price of each Department	42
→	2	ST Department LC and Status Read: LC (Listing Capacity) and Status of each Department	42
→	3	ST PLU Table Read: Preset Price and Link Department of each PLU	43
→	4	ST Other Programmed Data Read: %+ & %- Preset Rates, common LC for All Departments, Drawer Warning Time, Foreign Currency Exchange Rate, Cash Payment Key Amount, Vendor Coupon Limit Amount, LC for Tender Media, GST Rate for Canada, Non-taxable Limit Amount for Canada	44
→	5	ST System Option Read 1: System Option Setting, Addresses 1 to 13	45
→	6	ST Department Gross Profit Rates Read: Gross Profit Rates of each Department	43
→	9	ST System Option Read 2: System Option Setting, Addresses 1 to 24	45
→		Tax Calculation Test: Refer to page 45.	45

Department Preset Price Read

<p>TEC STORE 1343 PEACH DRIVE PHONE: 87-6437</p> <p>Open 8:00am to 7:00pm Closed: every Wednesday</p> <p>11-28-1997 #112300</p>	
Department Name	P X
Department No.	01 MEAT 7.00
	02 FISH
	03 DRINK
	04 BAKERY
	05 DP05
	06 DP06
	0319 23:20TM

Preset Price
(Those with blank price are Open-price Departments.)

NOTE: For changing the preset price or the Open-price/Preset-price status of any department, refer to "Department Preset Price Setting or Changing" in Chapter 4.

Department LC and Status Read

<p>TEC STORE 1343 PEACH DRIVE PHONE: 87-6437</p> <p>Open 8:00am to 7:00pm Closed: every Wednesday</p> <p>11-28-1997 #112300</p>	
Department Name	P X
Department No.	01 MEAT 01F 73
Department	01
Group No.	02 FISH 02F 94
	01
	03 DRINK 03 57
	02
	04 BAKERY 01 00
	02
	05 DP05 10 00-
	03
	06 DP06 40 00
	03
	0320 23:20TM

Key Type Status
0: Itemized
1: Single-item
4: Other Income
5: Other Income (Single-item)

Food Stamp Status or GST Status
F: Food Stampable
T: GST Taxable

Positive/Negative Status
-: Negative
Blank: Positive

Individual Department LC

Tax Status
1: Tax 1 taxable
2: Tax 2 taxable
3: Tax 1 & Tax 2 taxable
4: Tax 3 taxable
5: Tax 1 & Tax 3 taxable
6: Tax 2 & Tax 3 taxable
7: Tax 1 & Tax 2 & Tax 3 taxable
0: Non-taxable

NOTE: For changing the status of department, refer to "Department Status Programming" in Chapter 4. For setting or changing the following items, ask your TOSHIBA TEC representative.

- Classification of Department Group
- Individual Department LC

PLU Table Read

TEC STORE 1343 PEACH DRIVE PHONE: 87-6437 Open 8:00am to 7:00pm Closed: every Wednesday 11-28-1997 #112300			
PLU Code	P X		Link Department No. Preset Price (Blank Price means an Open-price PLU.)
PLU100	01	2.00	
PLU Name	Pork		
PLU101	01	3.00	
	Beef		
PLU200	02	5.00	
	Salmon		
PLU201	02	2.00	
	Shrimp		
PLU300	03	1.00	
	Coke-A		
PLU301	03	1.00	
	Coke-B		
PLU400	04	3.00/ 8	Whole Package Quantity
	Bun-A		
PLU401	04	1.50/ 3	
	Bun-B		
PLU500	05	0.50	
	PLU500		
	0321 23:20TM		

NOTE: For changing the programmed data of PLUs, refer to the following sections in **Chapter 4**.

- PLU Table Setting, Changing or Deletion (for any change)
- PLU Preset Price Changing (for Preset Price and Whole Package Quantity changing only)

Department Gross Profit Rates Read

TEC STORE 1343 PEACH DRIVE PHONE: 87-6437 Open 8:00am to 7:00pm Closed: every Wednesday 11-28-1997 #112300			
Department Name	P X		Gross Profit Rate
Department No.	01	MEAT	10%
	02	FISH	15%
	03	DRINK	20%
	04	BAKERY	25%
	0329 23:24TM		

NOTE: For changing the Department Gross Profit Rate, ask your TOSHIBA TEC representative.

Other Programmed Data Read

TEC STORE		
1343 PEACH DRIVE		
PHONE: 87-6437		
Open 8:00am to 7:00pm		
Closed: every Wednesday		
11-28-1997	#112300	
P X		
V.CPN	20.00	Vendor Coupon Limit Amount
CATEND	34	Respective LCs for each Tender Media
CHECK	00	
Chg	00	
MISC	00	
CPN	00	
FS TL	35	Common LC for All Departments
	86	
%+	10%	%+ Preset Rate
%-	5%	%- Preset Rate
GST	7%	GST Rate
	20.00	Non-taxable Limit Amount
CUR1	0.7143*	Exchange Rate for the [CUR1] Key
CUR2	0.5321*	Exchange Rate for the [CUR2] Key
01 CASH	10.00	Preset Cash Amount for the [\$5.00] (Cash Payment 1) Key
02 CASH	20.00	Preset Cash Amount for the [\$10.00] (Cash Payment 2) Key
	20	Drawer Warning Time
0328 23:23TM		

- NOTE:** For changing %+ or %- Preset Rate, refer to “% Key Preset Rate Setting or Changing” in **Chapter 4**.
- For changing Foreign Currency Exchange Rate, refer to “Foreign Currency Exchange Rate Setting” in **Chapter 4**.
- For changing Vendor Coupon Limit Amount, refer to “Vendor Coupon Limit Amount Setting” in **Chapter 4**.
- For changing LC for Tender Media, refer to “Listing Capacity Setting for Tender Media” in **Chapter 4**.
- For setting or changing the following items, ask your TOSHIBA TEC representative.
- Common LC for all Departments
 - Drawer Warning Time
 - Preset Cash Amount for the Cash Payment Keys
 - GST Rate
 - Non-taxable Limit Amount

System Option Read 1

TEC STORE	
1343 PEACH DRIVE PHONE: 87-6437	
Open 8:00am to 7:00pm Closed: every Wednesday	
11-28-1997 #112300	
P X	SET Bit Nos.
#01	2678
#02	0
#03	0
#04	0
#05	0
#06	234
#07	167
#08	23
#09	235
#10	0
#11	0
#12	0
#13	0
Address No.	
0024 20:20TM	

System Option Read 2

TEC STORE	
1343 PEACH DRIVE PHONE: 87-6437	
Open 8:00am to 7:00pm Closed: every Wednesday	
11-28-1997 #112300	
P X	SET Bit Nos.
#01	2678
#02	0
#03	0
#04	0
#05	0
#06	234
#07	167
#08	23
#09	235
#10	0
#11	0
#12	0
#13	0
#14	0
#15	0
#16	23
#17	0
#18	0
#19	236
#20	0
#21	7
#22	0
#23	0
#24	0
Address No.	
0025 20:01TM	

NOTE: The "System Options" define selections of basic functions of the ECR in accordance with the requirements of the market and your store, such as Print/Non-print of items, Fraction Rounding Process, Function Key status, Tax Controls, etc. Usually, selections of those options are completed by your TOSHIBA TEC representative before the product delivery. However, if you are not satisfied with the current status of a function key, etc., ask your TOSHIBA TEC representative for a change.

If your issue a "System Option Read" receipt, the currently selected options are read by the "SET Bit Nos" printed, which will be helpful for the service person to guide you or visit your store for option changes.

Tax Calculation Test

... → (or ,)
 Enter any amount.

P X	10.00	} Amount entered Each Tax Amount calculated by respective Tax Tables or Tax Rates
TAX1	0.50	
TAX2	1.00	
TAX3	0.00	
0330 23:26TM		

Appendix

Make a copy of this sheet and use it when you input characters directly on the normal keyboard.

<u>LOG</u> RECEIPT	DP#
#	
,	ITEM CORR
-	@/FOR
SPACE	/
PLU	

	RF	JF
C		
7	8	9
4	5	6
1	2	3
0	00	•

A	F	K	P	U
B	G	L	Q	V
C	H	M	R	W
D	I	N	S	X
E	J	O	T	Y
ST	AT/TL		Z	



TEC
TEC CORPORATION