

2016 *FIRST*[®] Robotics Competition

Game Manual

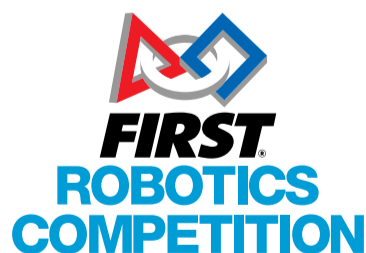

200 Bedford Street

Manchester, NH 03101, USA

<http://www.firstinspires.org/frc>

FIRST[®], the *FIRST*[®] logo, *FIRST*[®] Robotics Competition, *Coopertition*[®], *Gracious Professionalism*[®], and *Sport for the Mind*[™] are trademarks of the United States Foundation for Inspiration and Recognition of Science and Technology (*FIRST*[®]). © 2015-2016 *FIRST*. All rights reserved.

Official *FIRST*[®] Robotics Competition teams and Partners are permitted to make reproductions of this manual for team and Partner use only.

Any use, reproduction, or duplication of this manual for purposes other than directly by the team or Partner as part of *FIRST*[®] Robotics Competition participation is strictly prohibited without specific written permission from *FIRST*.

1

Introduction

1.1	A Message from the Woodie Flowers Award Recipients.....	2
1.2	Introduction.....	2
1.3	Description.....	3
1.4	Manual Conventions.....	4
1.5	Team Updates.....	4
1.6	Question and Answer System.....	4

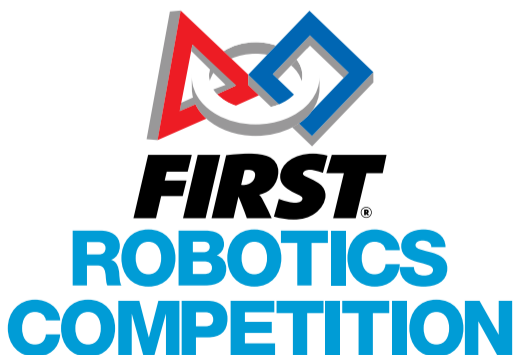

FIRST[®], the *FIRST*[®] logo, *FIRST*[®] Robotics Competition, *Coopertition*[®], *Gracious Professionalism*[®], and *Sport for the Mind*[™] are trademarks of the United States Foundation for Inspiration and Recognition of Science and Technology (*FIRST*[®]). © 2015-2016 *FIRST*. All rights reserved.

Official *FIRST*[®] Robotics Competition teams and Partners are permitted to make reproductions of this manual for team and Partner use only.

Any use, reproduction, or duplication of this manual for purposes other than directly by the team or Partner as part of *FIRST*[®] Robotics Competition participation is strictly prohibited without specific written permission from *FIRST*.

1 INTRODUCTION

1.1 A Message from the Woodie Flowers Award Recipients

The Woodie Flowers Award is the most prestigious mentoring award in *FIRST*. The recipients have created an important message for all *FIRST* Robotics Competition teams to consider as we start the new season.

Message from the Woodie Flowers Award Recipients

Performing at your best is important. Winning is important. This is a *competition*. However, winning the right way and being proud of what you have accomplished and how you have accomplished it is *more* important. *FIRST* could create rules and penalties to cover almost any scenario or situation, but we prefer an understandable game with simpler rules that allow us to think and be creative in our designs. We want to know that our partners and opponents are playing at their best in every match. We want to know they are playing with integrity and not using strategies based on questionable behaviors.

As you create your robots and award presentations, prepare for competition and match play, create and implement game strategies, and live your daily lives, remember what Woodie has said time and time again, and let's "Make your Grandmother proud."

The Woodie Flowers Award Recipients - Woodie Flowers, Liz Calef (88), Mike Bastoni (23), Ken Patton (51, 65), Kyle Hughes (27), Bill Beatty (71), Dave Verbrugge (67), Andy Baker (3940, 45), Dave Kelso (131), Paul Copioli (3310, 217), Rob Mainieri (2735, 812, 64), Dan Green (111), Mark Breadner (188), John Novak (16), Chris Fultz (234), John Larock (365), Earl Scime (2614), Fredi Lajvardi (842), Lane Matheson (932), Mark Lawrence (1816).

1.2 Introduction

Figure 1-1: *FIRST STRONGHOLD* Arena

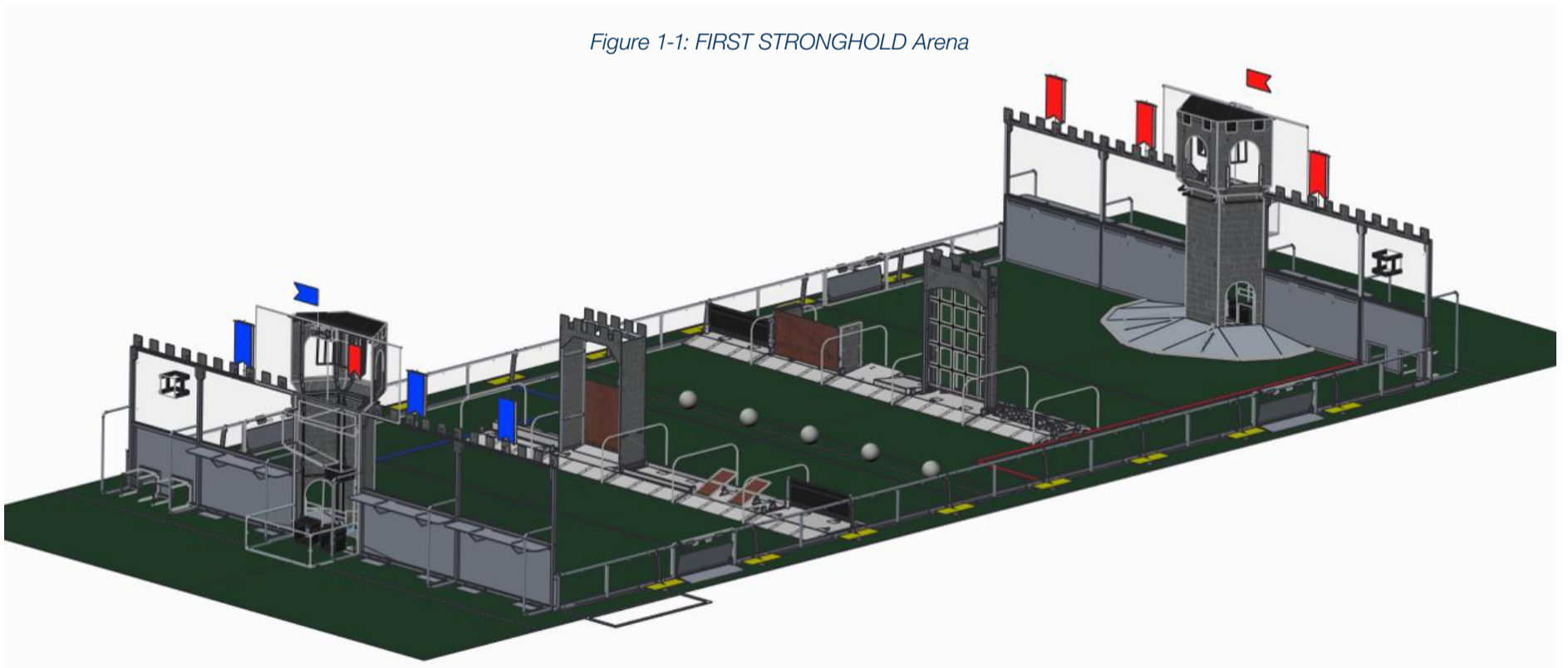

*FIRST STRONGHOLD*SM is played by two alliances of three teams each. Alliances compete against each other to breach their opponents' defenses, known as outer works, and capture their tower. They score points by crossing elements of their opponents' outer works, scoring boulders in their opponents' tower goals, and surrounding and scaling their opponents' tower itself.

1.3 Description

Full game play details may be found in later sections of this manual. The description below is a brief summary of key elements. Please read all sections of the manual very carefully.

FIRST STRONGHOLD is played on a 27 ft. by 54 ft. field. Each alliance commands one tower, five defenses, and a 'secret passage' which allows their robots to restock on ammunition, called boulders.

One defense in each alliance's set of five, the low bar, is a permanent part of the field. Three defenses are selected strategically by the alliance prior to the start of their match. The final defense changes periodically by audience selection.

Each *FIRST STRONGHOLD* match begins with a 15-second autonomous period in which robots operate independently of human control. During this period, robots attempt to cross opposing defenses and score in the opposing tower. Points for this period are shown in [Table 1-1](#).

Table 1-1: Auto Point Values

Action	Value
Reaching a defense	2
Crossing a defense	10
Boulder in a low tower goal	5
Boulder in a high tower goal	10

During the remaining 2 minutes and 15 seconds of the match, called the teleop period, robots are controlled by student drivers from behind their castle wall at the end of the field. Teams on an alliance work together to cross defenses, weaken the opposing tower by scoring boulders in it, and finally surround, scale and capture the tower.

Points for the match are awarded as shown in [Table 1-2](#).

Table 1-2: Teleop Point Values

Action	Value
Crossing a defense	5
Boulder in a low tower goal	2
Boulder in a high tower goal	5
Challenging the tower (per Robot)	5
Scaling the tower (per Robot)	15

Alliances are ranked by a combination of their Win-Loss-Tie record, breach success, and tower capture success. A win is determined by comparing total match points between alliances at the end of the match and earns an alliance two ranking points. Ties earn an alliance one ranking point. Capturing an opponents' tower at the end of the match earns each team on the alliance one ranking point. Breaching an opponents' outer works by crossing four of the five defenses twice earns an additional ranking point.

Ranking points are the primary way teams are ranked during qualification rounds, so are very important. Note that while only one alliance can win a match, either, both, or none may capture a tower or breach outer works.

1.4 Manual Conventions

Specific methods are used throughout this section to highlight warnings, cautions, key words and phrases. These conventions are used to alert the reader to important information and are intended help teams in constructing a robot that complies with the rules in a safe manner.

Key words that have a particular meaning within the context of the *FIRST* Robotics Competition and *FIRST STRONGHOLD* are defined in [Section 6: Glossary](#), and indicated in ALL CAPITAL letters throughout Sections 2 through 6.

References to other sections of this manual, the Administrative Manual, or external articles appear in italics.

The rule numbering scheme uses an indication of the section in which the rule is stated plus a serial numbering system. The Game rules begin with “G,” the Robot Rules begin with “R,” and the Tournament Rules begin with “T”. References to specific rules use this scheme (e.g. “G1” is the first rule in [Section 3: Game](#)).

Warnings, cautions and notes appear in blue boxes. It is strongly recommended that you pay close attention to their contents as they’re intended to provide insight into the reasoning behind a rule, helpful information on understanding or interpreting a rule, and/or possible “best practices” for use when implementing systems affected by a rule.

While blue boxes are part of the manual, they do not carry the weight of the actual rule (if there is an inadvertent conflict between a rule and its blue box, the rule supersedes the language in the blue box).

The intent of this manual is that the text means exactly, and only, what it says. Please avoid interpreting the text based on assumptions about intent, implementation of past rules, or how a situation might be in “real life.” There are no hidden requirements or restrictions. If you’ve read everything, you know everything.

1.5 Team Updates

Team updates are used to notify the *FIRST* Robotics Competition community of revisions to the official season documentation (e.g. the manual, field drawings, etc.) or important season news. Between kickoff and stop build day, team updates are posted each Tuesday and Friday. Between stop build day and the week before the *FIRST* Championship, team updates are posted each Tuesday. Team updates are posted [here](#) and are generally posted before 5 pm, Eastern Time.

Generally, team updates will follow the following convention:

- Additions will be highlighted in yellow. **This is an example.**
- Subtractions will be indicated with a strikethrough. ~~This is an example.~~
- Notes that are added for clarity or explanation for the change but are not retained as part of the manual appear in bold-italic. ***This is an example.***

1.6 Question and Answer System

Questions about the Administrative or Game Manuals may be asked to *FIRST* using the official Question and Answer System (aka “the Q&A”). Details on the Q&A can be found at [here](#). The Q&A is intended to help clarify rules and sometimes the responses result in revisions to the text in the official manual (which is communicated using team updates).

The Q&A is not a resource to get rulings on hypothetical match strategies or situations or a design review of a robot system for legality. The responses in the Q&A do not supersede the text in the manual, although every effort will be made to eliminate inconsistencies between the two. While responses provided in the Q&A may be used to aid discussion at each event, per [Section 5: Tournament](#), the Head Referee and Lead Robot Inspector are the ultimate authority on game rules and robot rules respectively. If you have concerns about trends of enforcement of rules by these volunteer authorities, please notify *FIRST* using frcteams@firstinspires.org.

FIRST[®], the *FIRST*[®] logo, *FIRST*[®] Robotics Competition, *Coopertition*[®], *Gracious Professionalism*[®] are registered trademarks, and *Sport for the Mind*[™] and *FIRST STRONGHOLD*SM are common law trademarks, of the United States Foundation for Inspiration and Recognition of Science and Technology (*FIRST*[®]). ©2016 *FIRST*[®]. All rights reserved.

2

Arena

2.1	Zones & Markings	2
2.2	FIELD	3
2.2.1	GUARDRAIL	4
2.2.2	OUTER WORKS	4
2.2.2.1	DEFENSES	5
2.2.2.2	SECRET PASSAGE	11
2.2.3	CASTLES	12
2.2.3.1	CASTLE WALL.....	12
2.3	BOULDERS	20
2.4	The FIELD Management System.....	21

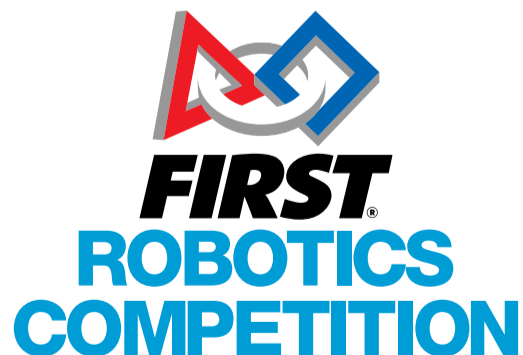

FIRST®, the *FIRST*® logo, *FIRST*® Robotics Competition, Coopertition®, Gracious Professionalism®, and Sport for the Mind™ are trademarks of the United States Foundation for Inspiration and Recognition of Science and Technology (*FIRST*®). © 2015-2016 *FIRST*. All rights reserved.

Official *FIRST*® Robotics Competition teams and Partners are permitted to make reproductions of this manual for team and Partner use only. Any use, reproduction, or duplication of this manual for purposes other than directly by the team or Partner as part of *FIRST*® Robotics Competition participation is strictly prohibited without specific written permission from *FIRST*.

Figure 2-1: FIRST STRONGHOLD Arena

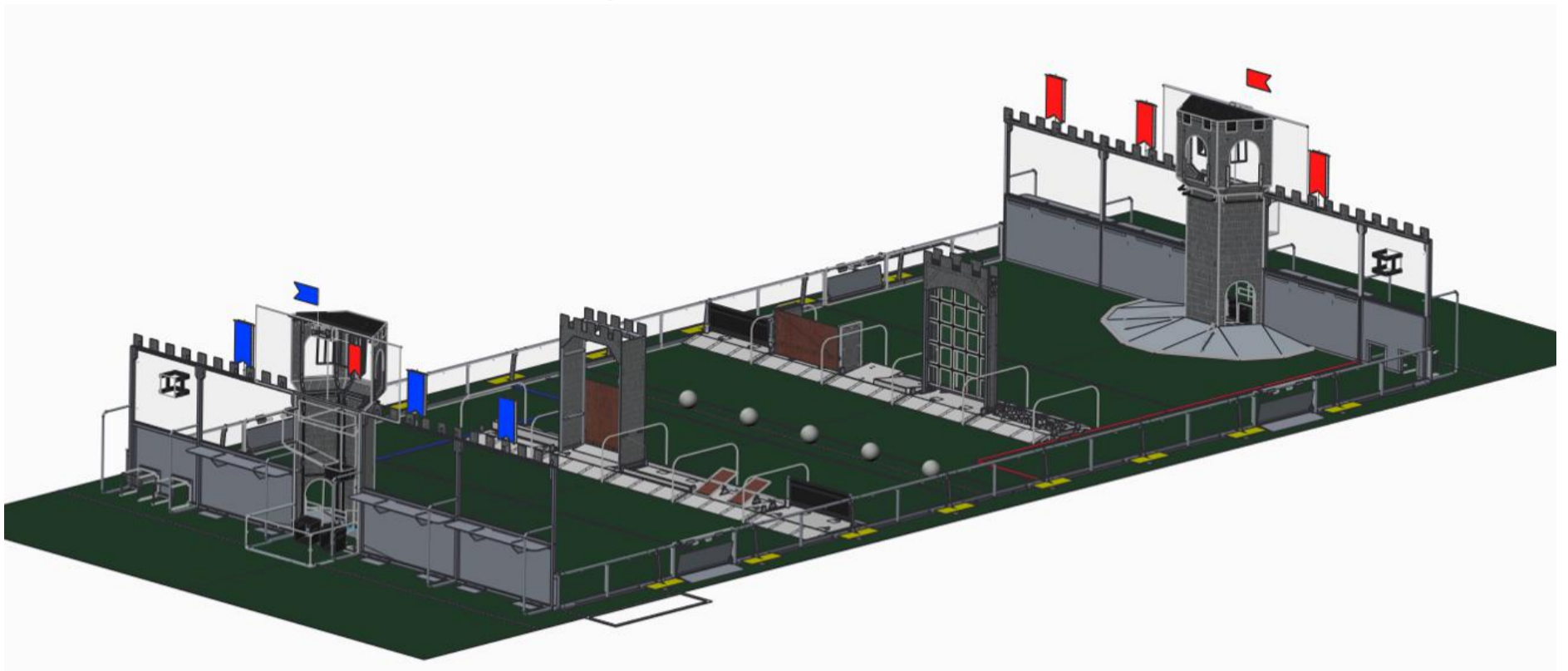

*FIRST STRONGHOLD*SM is a medieval tower defender game in which two (2) ALLIANCES of three (3) Teams each select DEFENSES to fortify their OUTER WORKS before competing simultaneously to score points while BREACHING the opponent's OUTER WORKS and CAPTURING the opponent's TOWER.

The ARENA includes all elements of the game infrastructure that are required to play *FIRST STRONGHOLD*: the FIELD, the CASTLES, the scoring elements, and all equipment needed for FIELD control, ROBOT control, and scorekeeping.

The competition ARENA is modular and assembled, used, disassembled, and shipped many times during the competition season. It will undergo wear and tear. The ARENA is designed to withstand rigorous play and frequent shipping. Every effort is made to ensure that ARENAS are consistent from event to event. However, ARENAS are assembled in different venues by different event staff and some small variations occur. For details regarding assembly tolerances, please refer to the [2016 ARENA Layout and Marking Drawing](#). Successful Teams will design ROBOTS that are insensitive to these variations.

Illustrations included in this section are for a general visual understanding of the *FIRST STRONGHOLD* ARENA, and dimensions included in the manual are nominal. Please refer to the official drawings for exact dimensions, tolerances, and construction details. The official drawings, CAD models, and drawings for low-cost versions of important elements of the *FIRST STRONGHOLD* FIELD are posted on the [2016 Official FIRST Field Drawings & Models](#) web page.

2.1 Zones & Markings

The *FIRST STRONGHOLD* ARENA contains the following areas and volumes relevant to game play. Each element is identified in [Figure 2-2](#).

- COURTYARD: an infinitely tall volume bordered by, but excluding, the CASTLE WALL, the GUARDRAIL, the SECRET PASSAGE and the OUTER WORKS.
- NEUTRAL ZONE: an infinitely tall volume formed by, but not including, the BERMS, the GUARDRAILS and OUTER WORKS.

- **OUTER WORKS:** an infinitely tall volume bordered by, but not including, the GUARDRAIL, the SECRET PASSAGE, and the bottom edges of the PLATFORM ramps. The OUTER WORKS is positioned 7 ft. 2 in. from the MIDLINE.
- **SECRET PASSAGE:** an infinitely tall, 4 ft. 5-1/2 in. wide, 23 ft. 11-1/2 in. deep volume defined by the BERMS, the GUARDRAIL and the CASTLE WALL. The SECRET PASSAGE includes the BERMS, but does not include the GUARDRAILS or CASTLE WALL.
- **SPY BOX:** a 6 ft. wide by 2 ft. deep, infinitely tall volume, bounded by and including 2 in. white gaffers tape, located adjacent to the to the edge of the opposing CASTLE and the 18 in. from the GUARDRAIL.

The ARENA contains the following additional markings:

- **MIDLINE:** a line of 2 in. white gaffers tape that bisects the length of the FIELD.
- **AUTO LINE:** a 2 in. wide line of green gaffers tape that is 12 in. from the edge of the Midline.
- **STARTING LINE:** a 2 in. white gaffers tape line that is the width of the CASTLE and is 2 ft. 6 in. from the CASTLE WALL
- **ALIGNMENT LINE:** A 2 in. wide line of green gaffers tape that is 11 ft. from the CASTLE WALL.

Figure 2-2: Zones & Markings

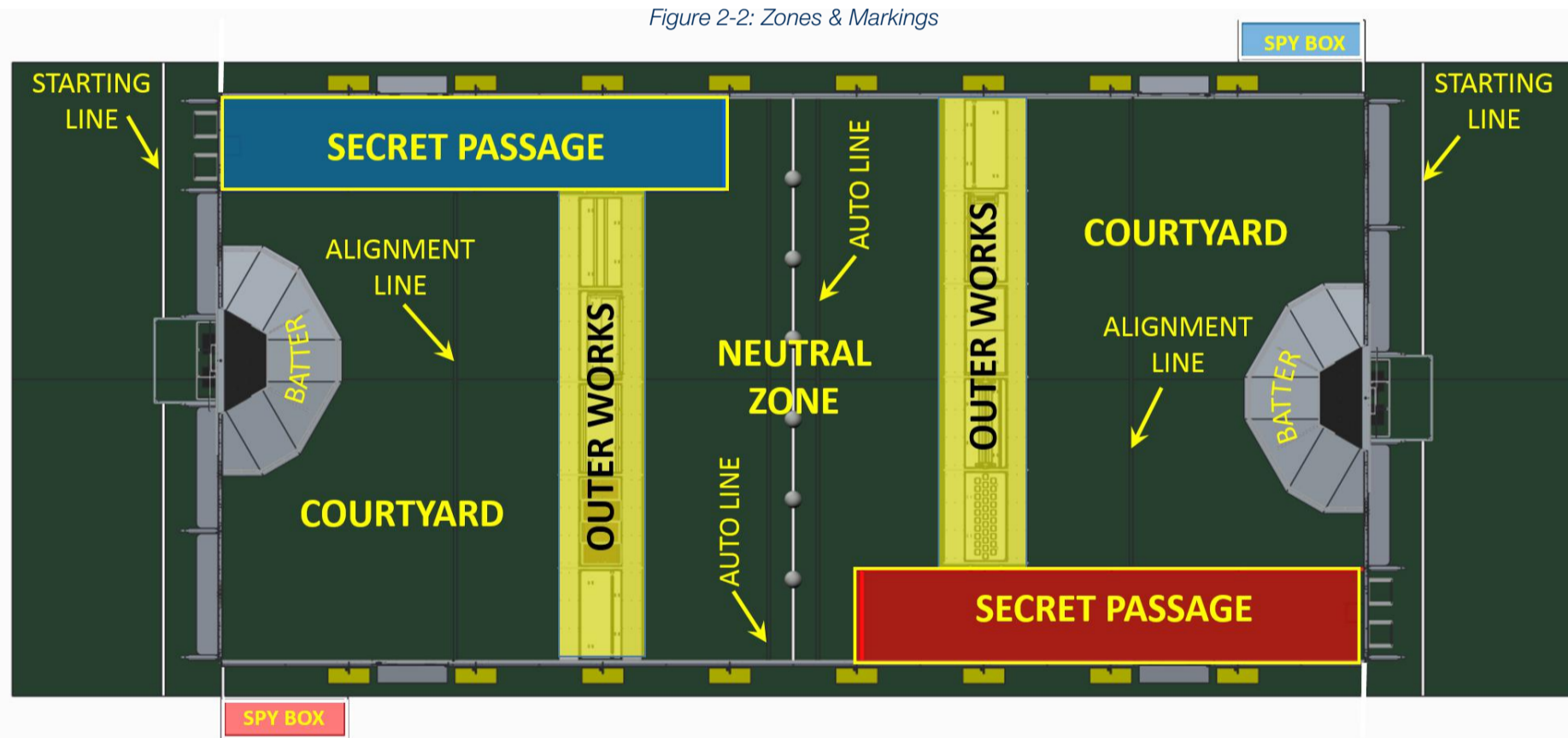

2.2 FIELD

The FIELD for *FIRST STRONGHOLD* is a 26 ft. 7 in. by 54 ft. 1 in. carpeted area, bound by and including the inward-facing surfaces of the GUARDRAILS and two (2) CASTLES. The carpet used for the FIELD is green in color (Shaw Floors, Philadelphia Commercial, Neyland II 20, 30352, “Scotch Pine”).

There are two versions of GUARDRAILS and CASTLE WALLS used for competitions. One design has been used at FRC competitions for several years and matches the [2016 Official FIRST Field Drawings & Models](#). The other was designed and is sold by AndyMark. While the designs are slightly different, the critical dimensions, performance, and expected user experience between the two is the same. All Regional and Championship assemblies will use the traditional *FIRST* design. Teams may contact their local District leadership for details on which assembly is used by their District. Detailed drawings for the AndyMark design are posted on the [AndyMark](#) website. All illustrations in the Game Manual show the traditional FIELD design.

2.2.1 GUARDRAIL

The GUARDRAIL is a system that consists of transparent polycarbonate supported on the top and bottom by aluminum extrusion. The GUARDRAIL prevents ROBOTS from inadvertently exiting the FIELD during a MATCH.

There are four (4) gates in the GUARDRAIL that allow access to the FIELD for placement and removal of ROBOTS. The gates are 3 ft. 2 in. wide and closed and shielded during the MATCH.

Figure 2-3: Gate Location

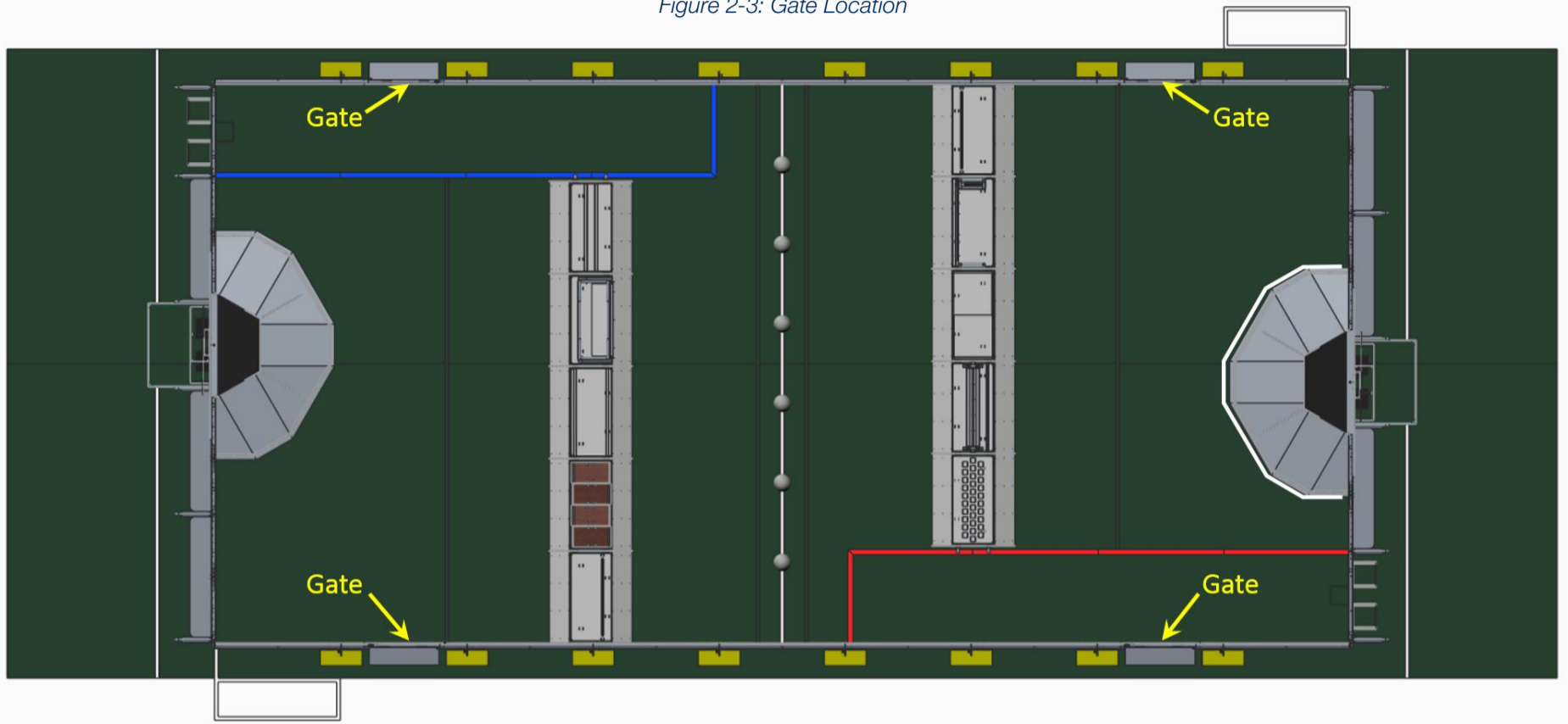

2.2.2 OUTER WORKS

The OUTER WORKS is an infinitely tall volume bordered by, but not including, the GUARDRAIL, the SECRET PASSAGE, and the bottom edges of the PLATFORM ramps. The OUTER WORKS is positioned 7 ft. 2 in. from the MIDLINE. It consists of a series of five (5) DEFENSES, five (5) PLATFORMS, and five (5) Shields arranged in a line across the FIELD and is designed to impede the passage of ROBOTS and BOULDERS in to the COURTYARD. Three (3) of the DEFENSES are selected by the ALLIANCE, one (1) is selected by the audience, and the one (1) is a permanently mounted Low Bar. (Figure 2-4 shows the locations of the Low Bar, ALLIANCE, and audience selected DEFENSES.)

1. Low Bar
2. ALLIANCE selected
3. Audience selected
4. ALLIANCE selected
5. ALLIANCE selected

Figure 2-4: OUTER WORKS DEFENSE Placement

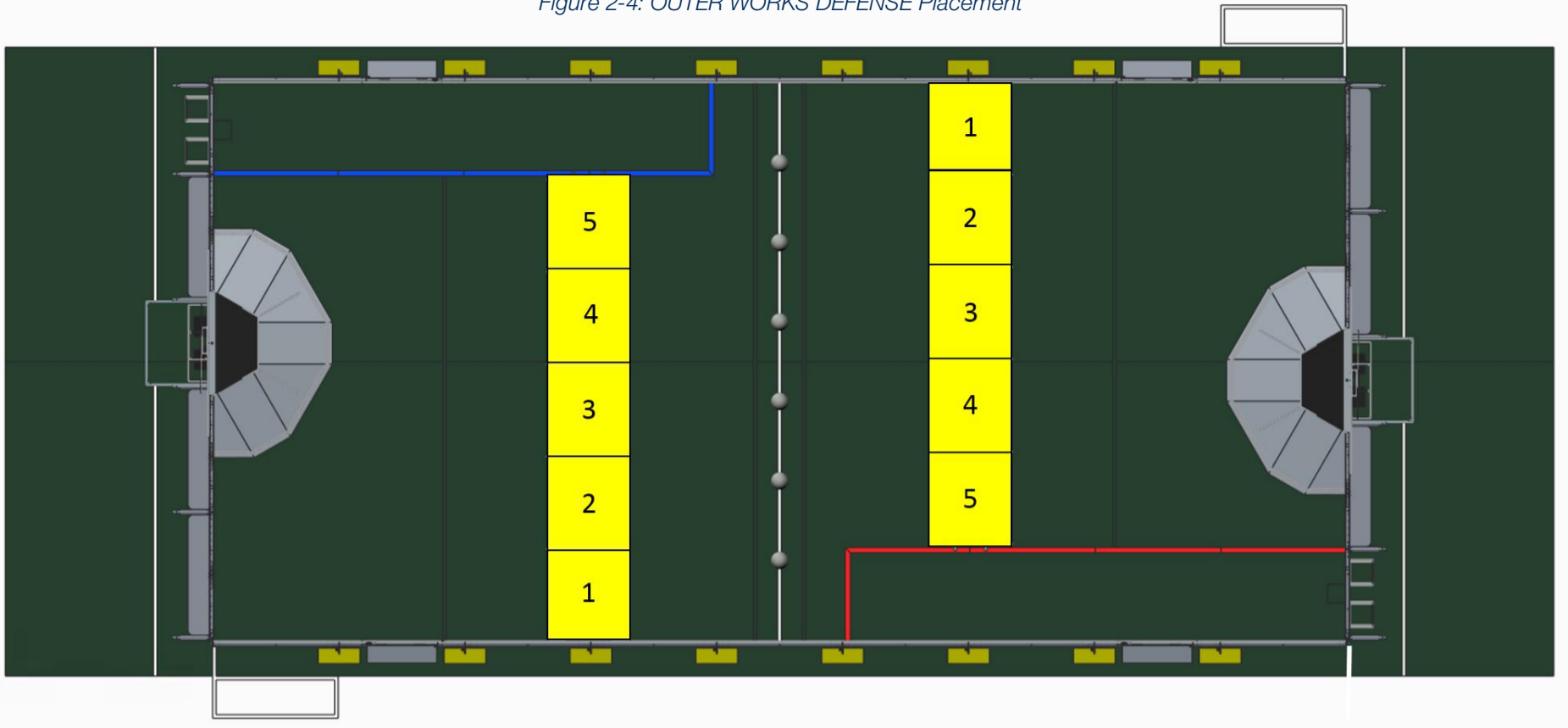

2.2.2.1 DEFENSES

A DEFENSE is one (1) of five (5) obstacles in the OUTER WORKS and on a PLATFORM. There are a total of eight (8) unique, selectable DEFENSES. These DEFENSES are arranged into four different categories. Each ALLIANCE selects one (1) DEFENSE from each category per [Section 5 \(5.5.10 Selecting Defenses\)](#).

Category A

Figure 2-5: Category A Selections

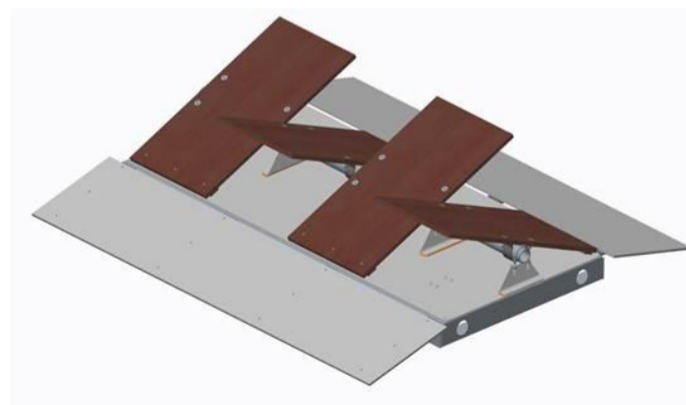

Portcullis

The Portcullis is an arched gateway with a door that opens when lifted up. The gateway is 3 ft. 8 in. wide and 5 ft. 2 in. tall. The door is constructed of a steel frame with a 1/8 in. thick polycarbonate sheet covering the opening in the frame. The door requires approximately 5 lbs. to lift from the bottom edge. When it is resting in its natural position there is a 5 in. gap below the door.

Figure 2-6: Portcullis Dimensions

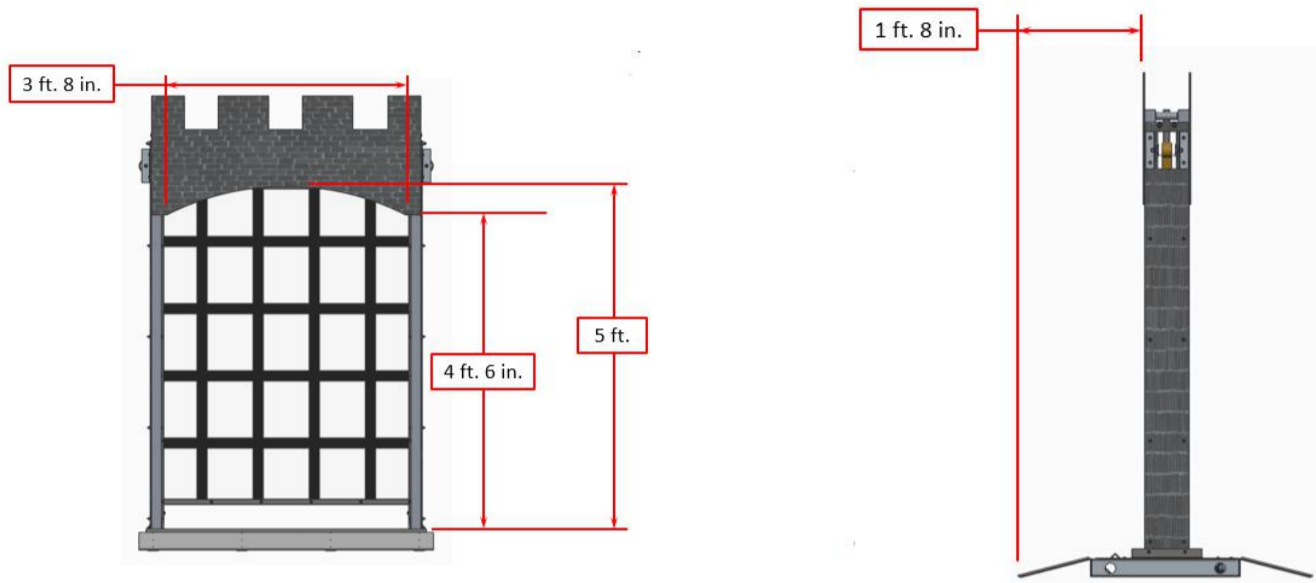

Cheval de Frise

The Cheval de Frise is a series of four (4) independently tilting, weighted polycarbonate platforms. The platforms rotate about a pipe in the middle and are weighted so that they rest on alternate sides. Platforms are 1 ft. wide and 2 ft. long and 1/2 in. thick. The axis of the pipe is 3-3/4 in. from the surface of the platform. The top edge of the platform is 9-5/8 in. from the DEFENSE platform. In order to tilt a platform, approximately 1 lbs. of force must be applied at the edge of the platform.

Figure 2-7: Cheval de Frise Dimensions

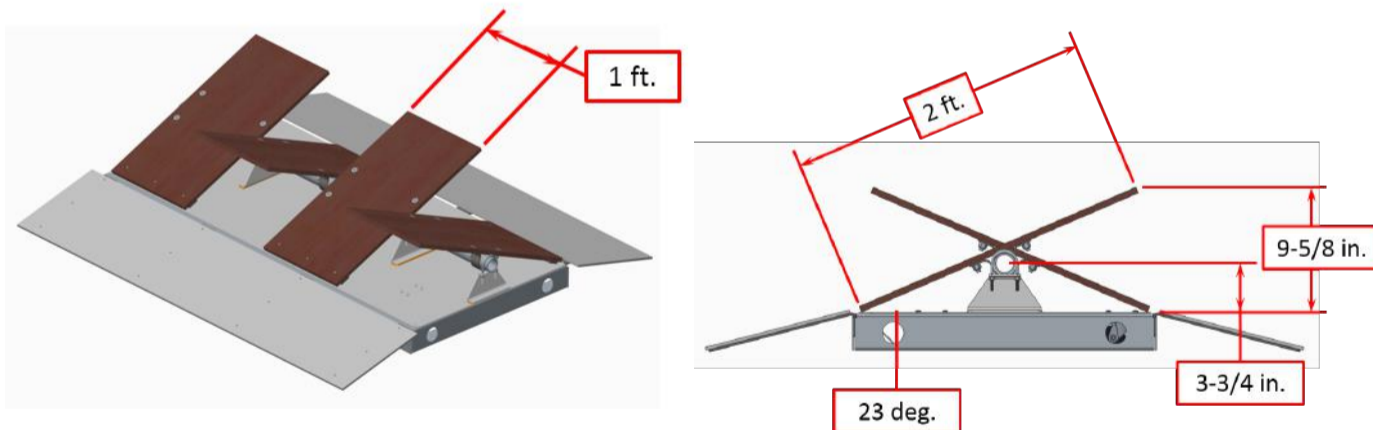

Category B

Figure 2-8: Category B Selections

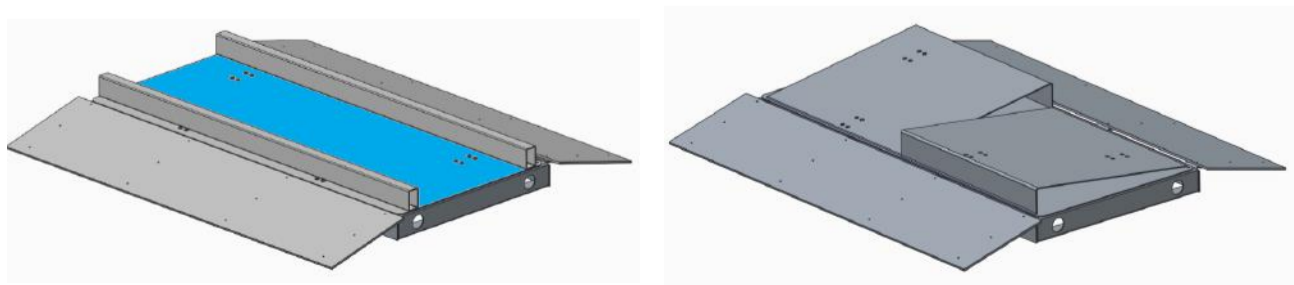

Moat

The Moat is a 2-1/2 in. high, 4 ft. 2 in. wide, and 1 ft. 8 in. deep u-shaped channel, formed by vertical rectangular steel tubes.

Figure 2-9: Moat Dimensions

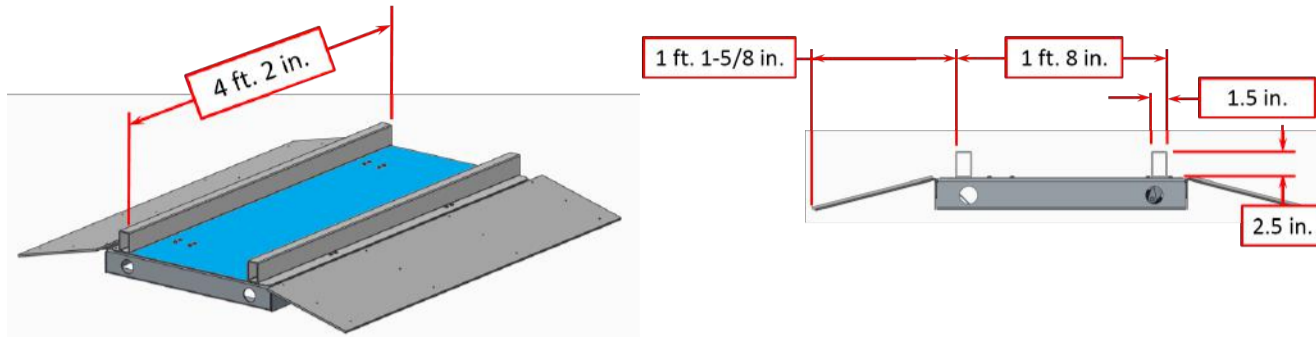

Ramparts

The Ramparts are two static, steel ramps, side by side, facing opposite directions. Each ramp is 2 ft. wide and 1 ft. 10 in. deep, set at an 8 deg. angle.

Figure 2-10: Ramparts Dimensions

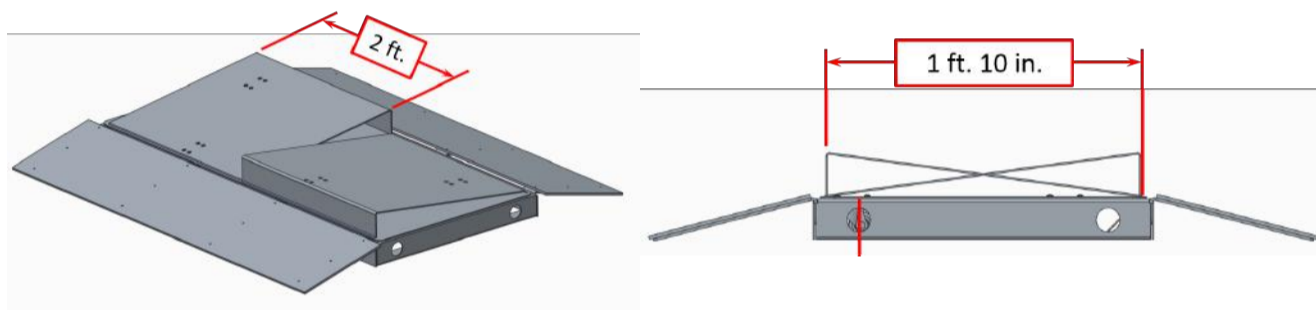

Category C

Figure 2-11: Category C Selections

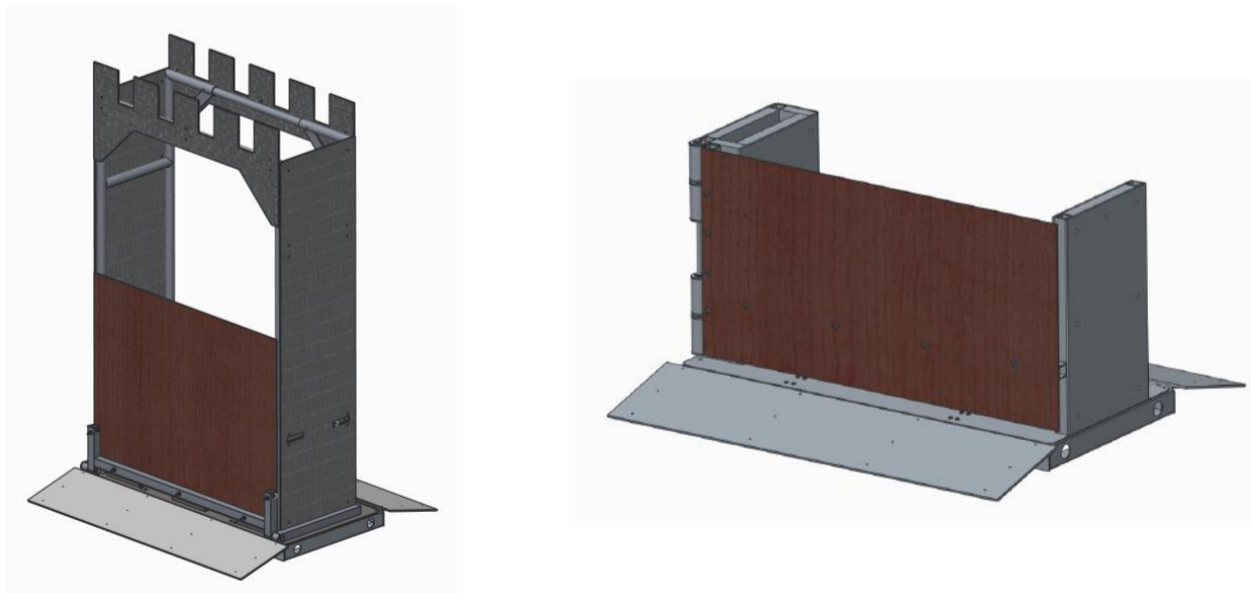

Drawbridge

The Drawbridge is an arched gateway with a door that lowers toward the NEUTRAL ZONE. The door is made from polycarbonate and is 37 in. tall and 1/4 in. thick. When the door is fully down, the opening is 3 ft. 6 in. wide and 5 ft. 5-3/4 in. tall (to the top of the center of the arch). The door is sprung so that it will return to a closed position when there is no weight on it. The door can be manipulated at any point, but for reference, it takes approximately 2 lbs. of force applied at the top edge of the door for it to begin to move. Once moving, the required force increases to a maximum of 5 lbs.

Figure 2-12: Drawbridge Dimensions

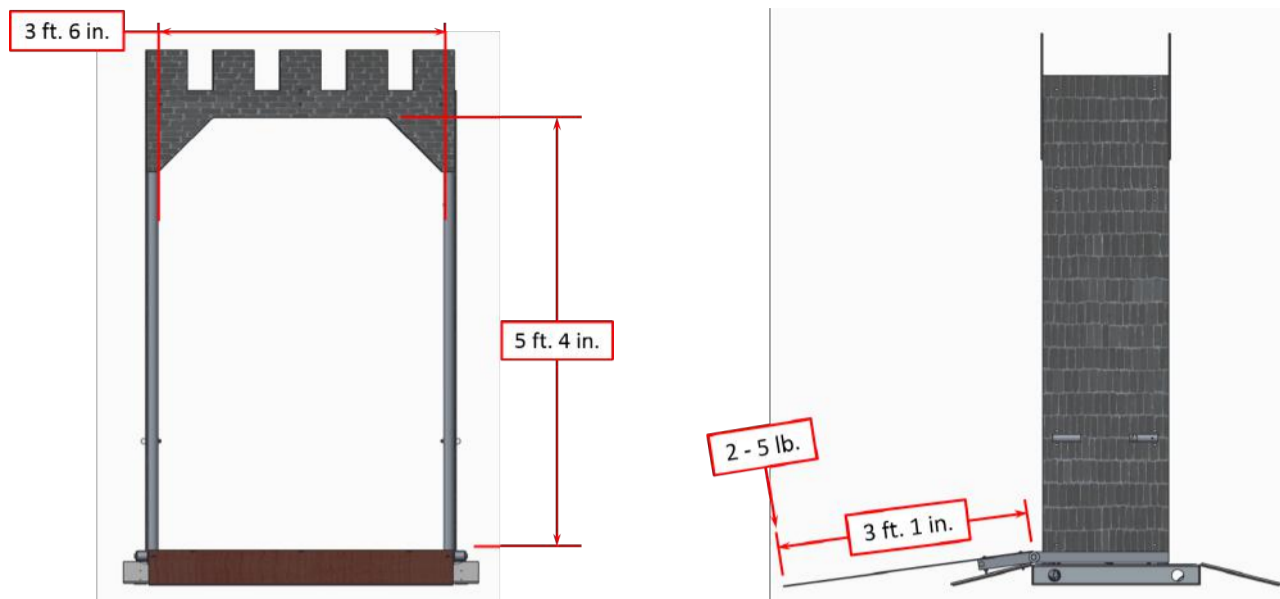

Sally Port

The Sally Port is a door $\frac{1}{4}$ " thick, 4 ft. wide, 2 ft. tall that can only swing toward the NEUTRAL ZONE. The opening is 3 ft. 6 in. wide. The top of the door is 2 ft. 1 in. from the surface of the platform. The door is sprung so that it will return to a closed position when it is not being held open. A force of approximately 1.5 lbs. must be applied to the outer edge of the door in order for it to open.

Figure 2-13: Sally Port Dimensions

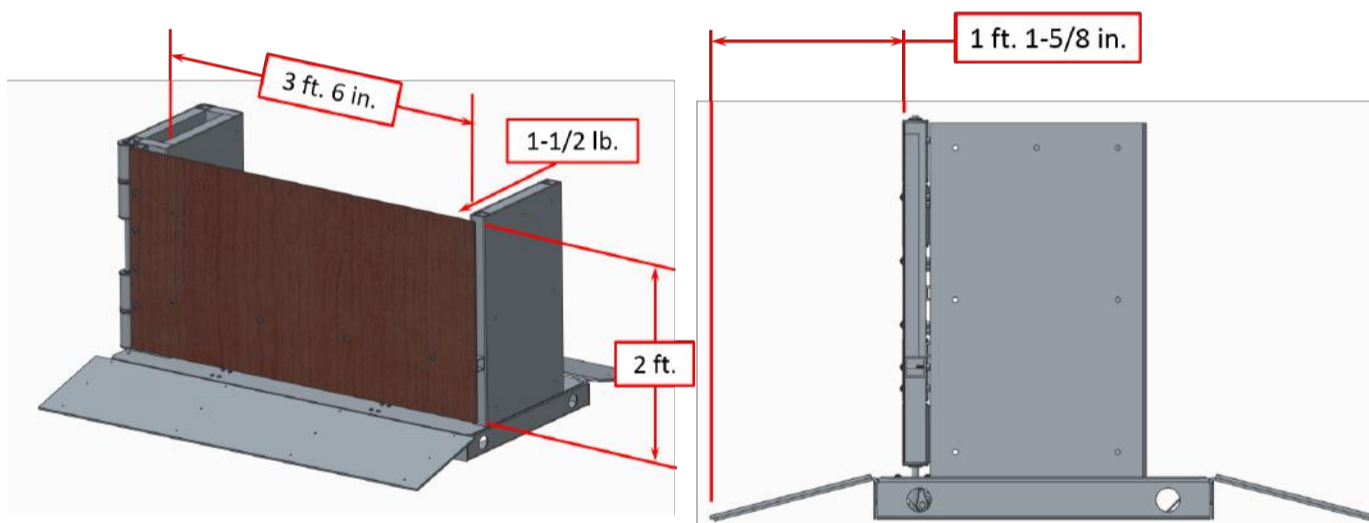

Category D

Figure 2-14: Category D Selections

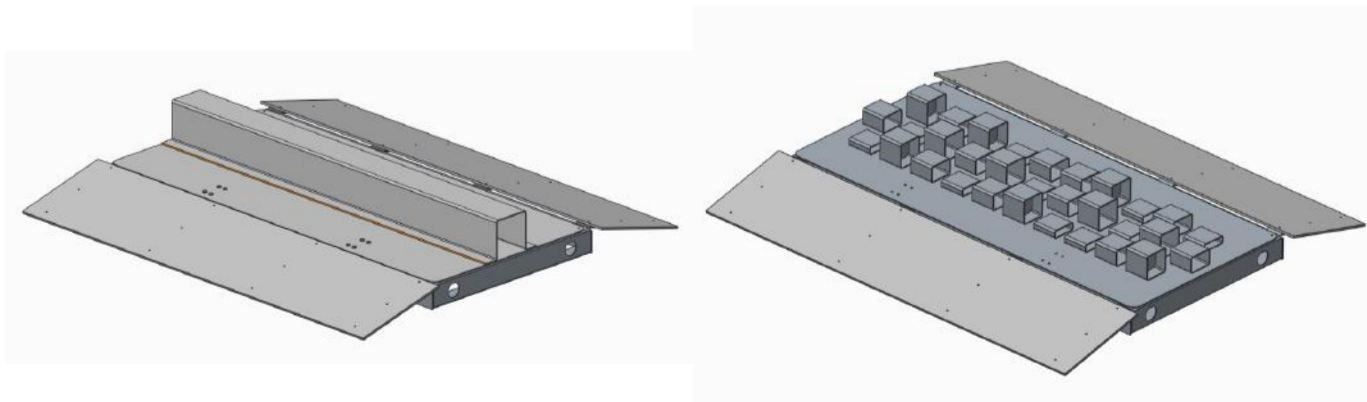

Rock Wall

The Rock Wall is a steel block that is 4 ft. 2 in. wide, 5- $\frac{1}{4}$ in. deep, and 4- $\frac{5}{8}$ in. tall.

Figure 2-15: Rock Wall Dimensions

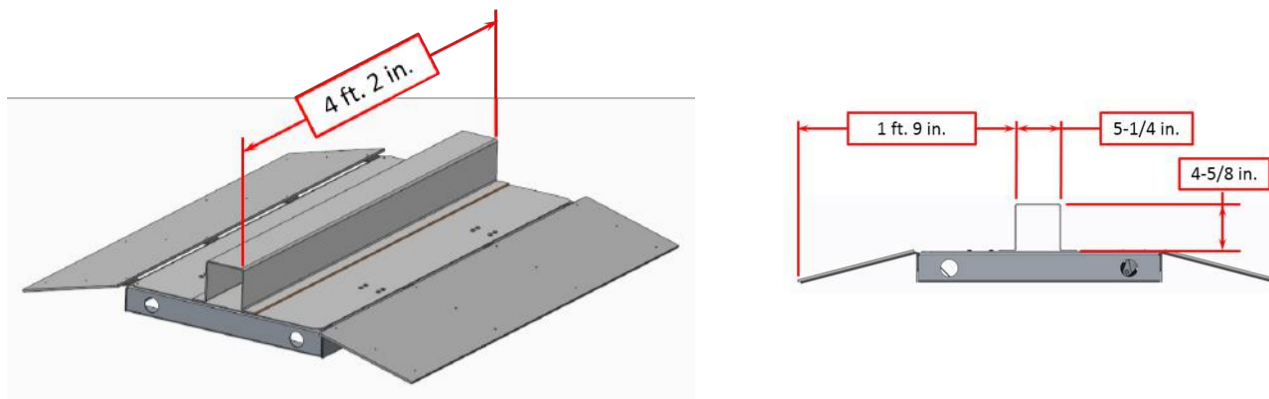

Rough Terrain

The Rough Terrain is constructed from thirty-one (31) pieces of square or rectangular steel tubing. There are three different sizes of steel tubing: 1 in. by 3 in., 2 in. by 3 in., and 3 in. by 3 in. All of the tubing is cut into 3 in. lengths. The tubing is then welded on to a steel plate to form a “random” series of bumps spaced 1- $\frac{1}{2}$ in. from each other. Please refer to the [2016 Official FIRST Field Drawings & Models](#) for complete information. The tubing is arranged in three rows. The first and third row have ten (10) pieces of tubing, while the second row has eleven (11). The tubing is spaced 1- $\frac{1}{2}$ in. apart.

Figure 2-16: Rough Terrain Dimensions

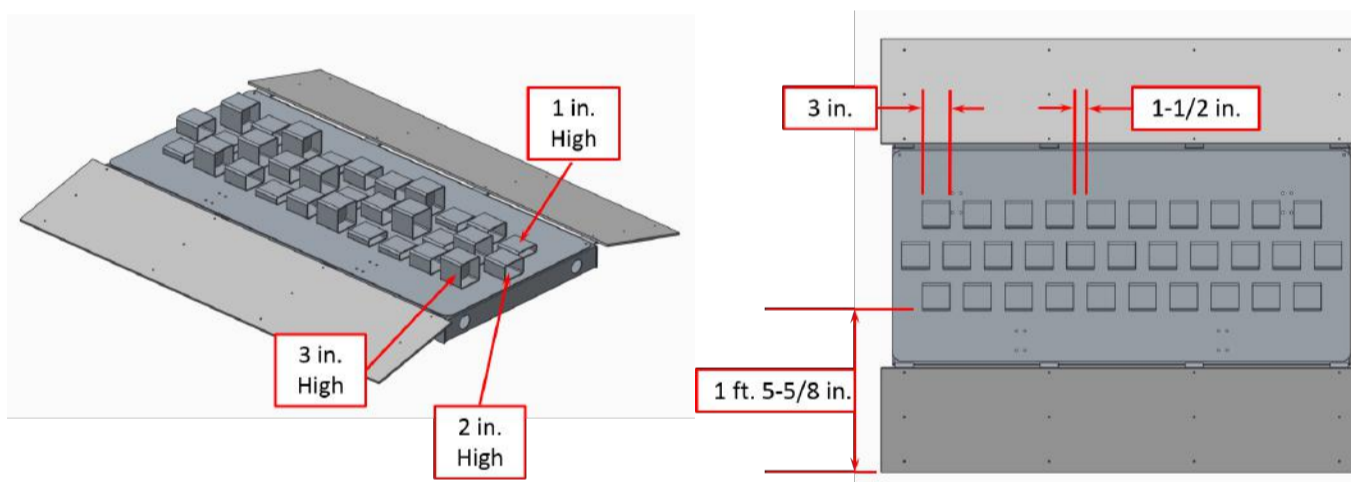

There is one (1) non-selectable DEFENSE.

Low Bar

The Low Bar is constructed from 1” 6061 Aluminum Schedule 40 pipe. The pipe creates an opening that is 1 ft. 4 in. tall and 3 ft. 10- $\frac{1}{2}$ in. wide. It features opaque walk-in freezer door flaps, designed to keep BOULDERS from passing through on their own. The material is McMaster-Carr part number 1894A214, opaque black. 33 $\frac{1}{2}$ -in. long strips are draped over the Low Bar at regular intervals and in such a way that the front and back flaps are of equal length with an approximate 1 in. gap between the base and the bottom of the flaps. The vinyl is secured to itself using cable ties just below the bar to allow free, independent rotation of individual strips. Additional cable ties are used to maintain spacing between the strips. The Low Bar is mounted 1 ft. 4- $\frac{1}{2}$ in. from edge of the PLATFORM on the NEUTRAL ZONE side of the OUTER WORKS.

Figure 2-17: Low Bar Dimensions

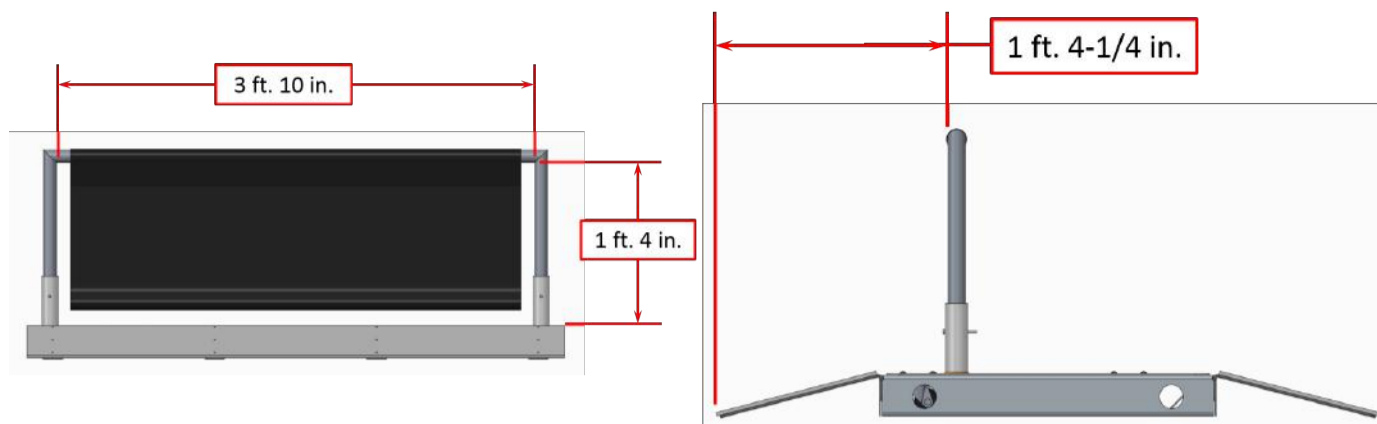

PLATFORMS

PLATFORMS are a 4 ft. 2 in. wide, 2 ft. deep and 3 in. tall base for a DEFENSE and associated ramps. Each PLATFORM is permanently installed on the FIELD and is abutted by translucent polycarbonate ramps on each long edge. Ramps are 4 ft. 2 in. wide, 1 ft. deep, resulting in a 13.5 deg. angle.

Figure 2-18: PLATFORM Dimensions

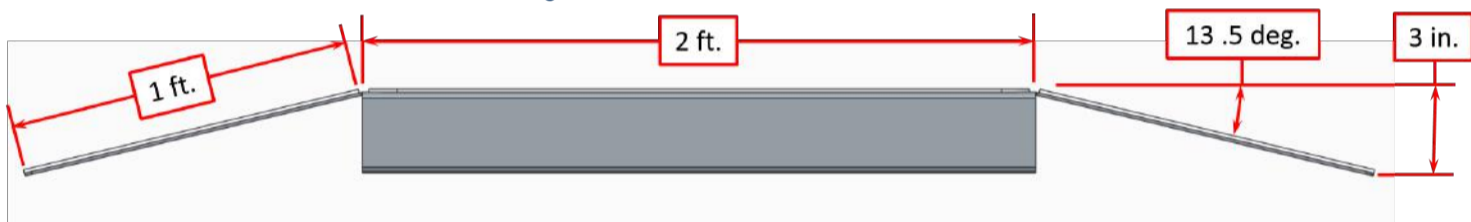

Each PLATFORM has indicator lights beneath the ramps to indicate that DEFENSE'S STRENGTH. Once a DEFENSE'S STRENGTH has been reduced to half STRENGTH (1), the outer lights will turn off, leaving the center third on. Once the DEFENSE'S STRENGTH is reduced to zero (0) all lights for that DEFENSE will turn off as indicated in [Figure 2-19](#).

Figure 2-19: DEFENSE lighting

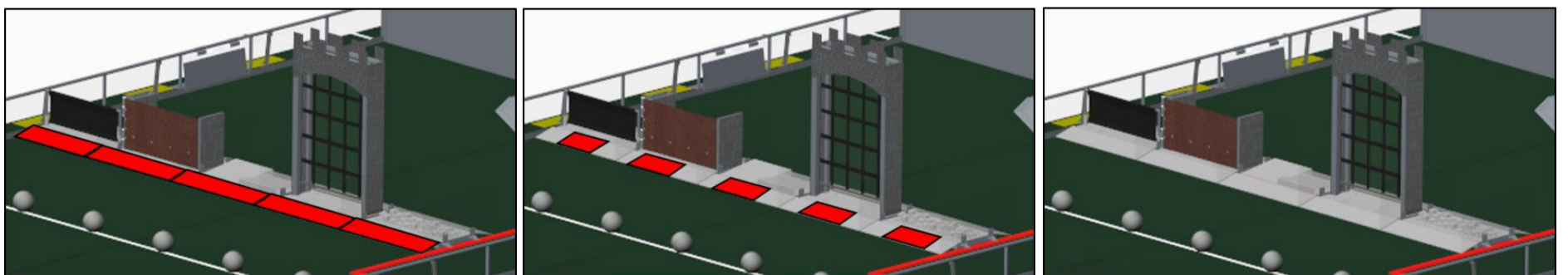

Full Strength

Half Strength

Zero Strength

These lights are used for other situations as well, as described in [Table 2-1](#).

Table 2-1: DEFENSE lighting states and meanings

Light State	Meaning
Off	Prior to start of MATCH: FIELD is ready for the MATCH to begin, all personnel should be off the FIELD at this time. During MATCH: DEFENSE with no (0) STRENGTH.
Alliance Color (all)	DEFENSE with full (2) STRENGTH
Alliance Color (half)	DEFENSE with half (1) STRENGTH

Shields

Separating each DEFENSE/PLATFORM pair, and the OUTER WORKS from the SECRET PASSAGE BERM, is a 3/8" thick polycarbonate Shield, 4 ft. deep and 2 ft. tall. Shields are highlighted in yellow in [Figure 2-20](#).

Figure 2-20: Shield Locations

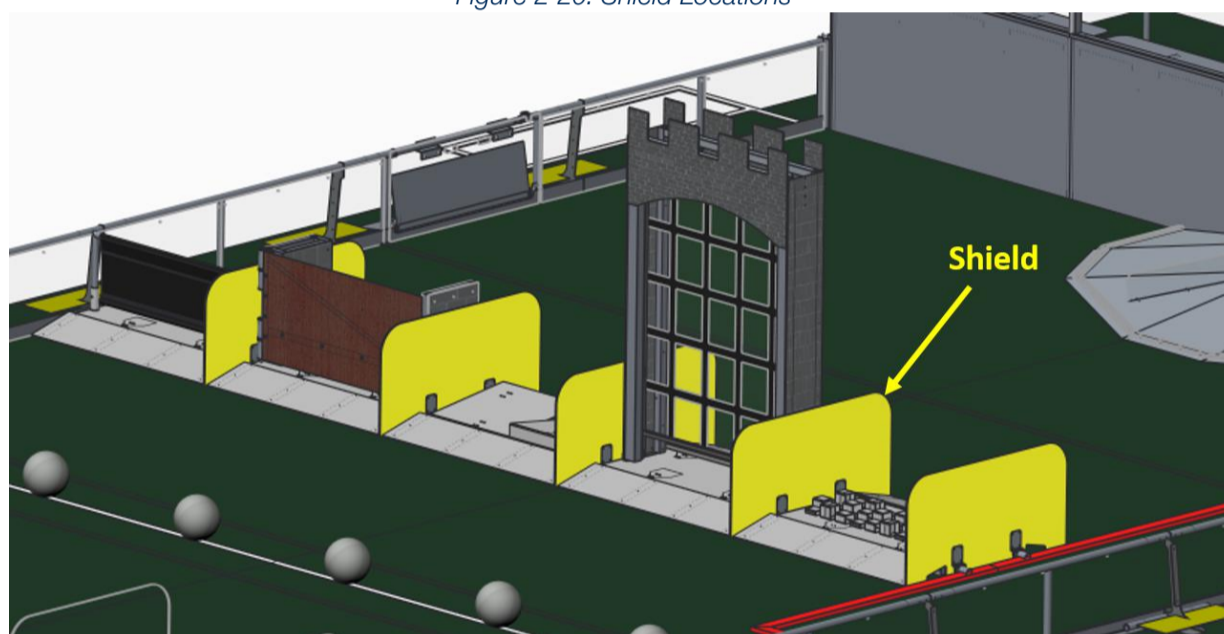

2.2.2.2 SECRET PASSAGE

A SECRET PASSAGE is a rectangular lane in front of each HUMAN PLAYER STATION. As introduced in [Section 2.1 Zones & Markings](#), each ALLIANCE has a SECRET PASSAGE; an infinitely tall, 4 ft. 5-1/2 in. wide, 23 ft. 11-1/2 in. deep volume defined by BERMS, the GUARDRAIL and the CASTLE WALL.

The SECRET PASSAGE includes the BERMS, but does not include the GUARDRAIL or CASTLE WALL. BERMS consist of a steel barrier, 1 in. tall and 3 in. wide that defines the border of the SECRET PASSAGE.

Figure 2-21: Cross Section of the SECRET PASSAGE BERM

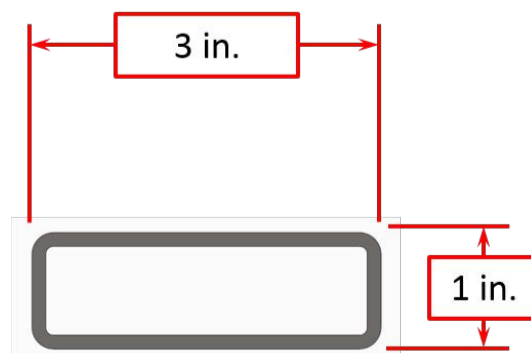

2.2.3 CASTLES

Figure 2-22: Red and Blue CASTLES

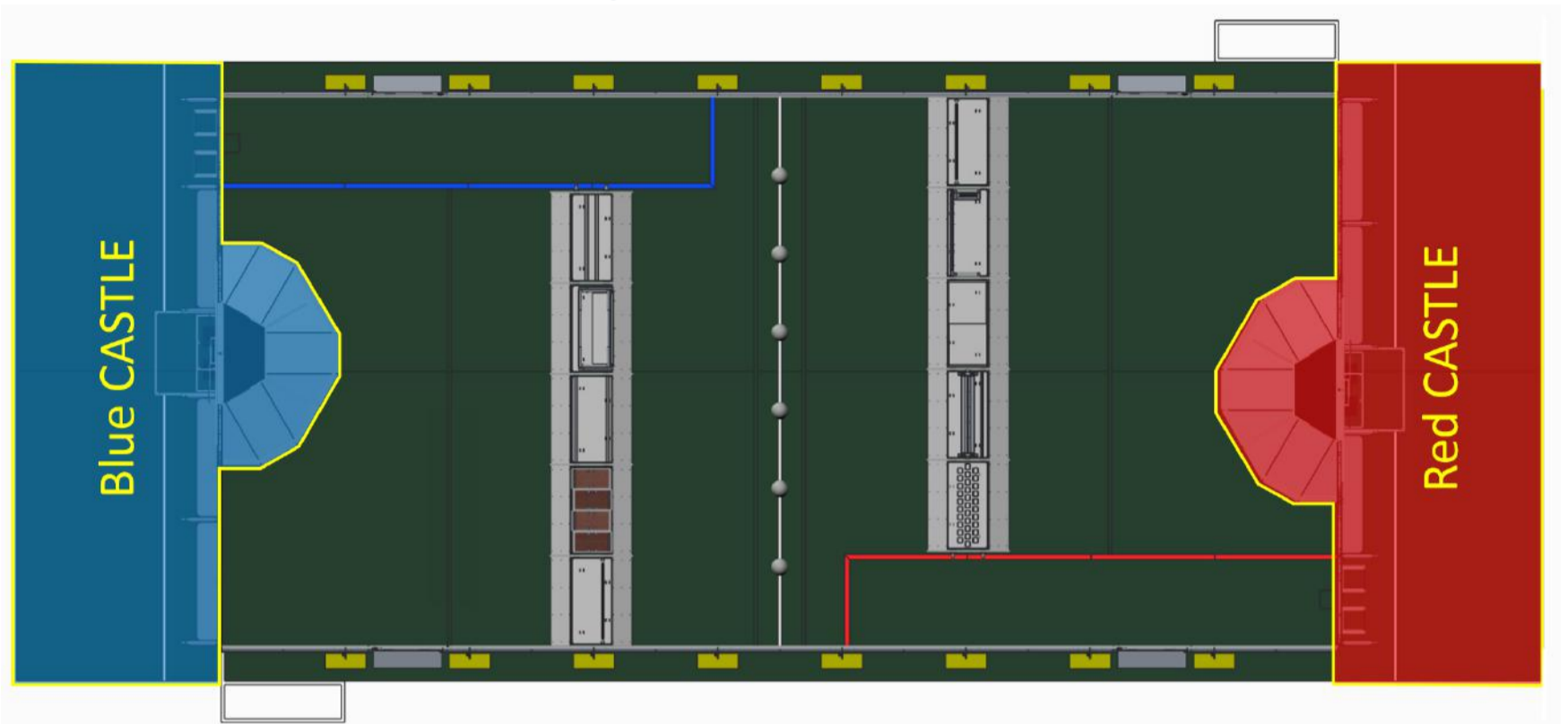

A CASTLE is located on each end of the FIELD. Each CASTLE is bounded by and includes the edges of the carpet, the CASTLE WALL, and white gaffers tape.

2.2.3.1 CASTLE WALL

The CASTLE WALL is the barrier between ROBOTS and DRIVE TEAMS (with the exception of a SPY in the SPY BOX) that consists of three (3) PLAYER STATIONS, a HUMAN PLAYER STATION, and a TOWER.

Figure 2-23: Red CASTLE WALL

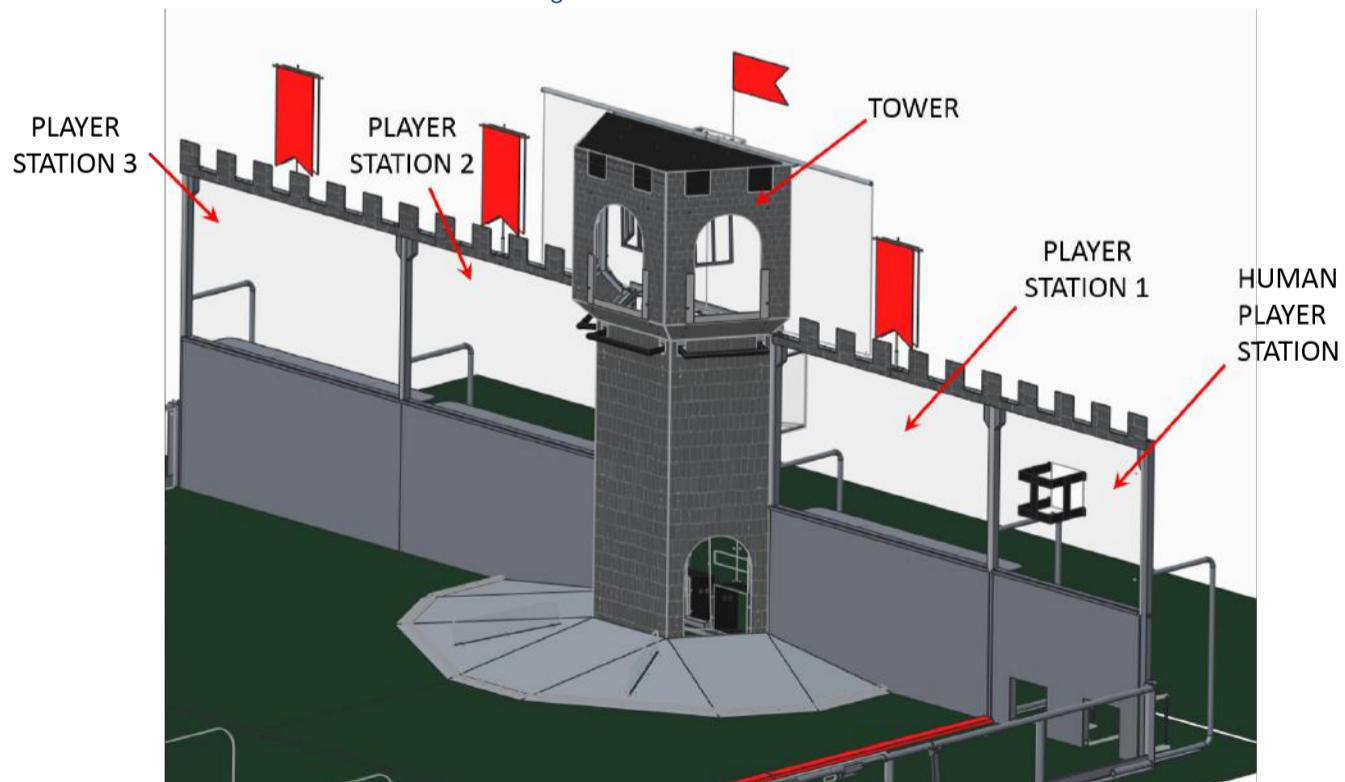

PLAYER STATION

A PLAYER STATION is one (1) of three (3) assigned positions behind a CASTLE WALL from where a DRIVE TEAM operates their ROBOT. Each PLAYER STATION is made from a 3 ft. tall diamond plate panel base topped with a 3 ft. 6 in. tall transparent plastic panel. An aluminum shelf is attached to each PLAYER STATION to support the DRIVE TEAM'S OPERATOR CONSOLE. The shelf is 5 ft. 9 in. wide and 1 ft. deep. There is a 4 ft. 6 in. long by 2 in. wide strip of hook-and-loop tape ("loop" side) along the center of the support shelf that may be used to secure the OPERATOR CONSOLE to the shelf.

Each Player Station supports one (1) Standard Holder. The Standard Holder features a receptacle designed to hold a 1/2 in. diameter rod and is mounted above the team sign.

Figure 2-24: Standard Holder

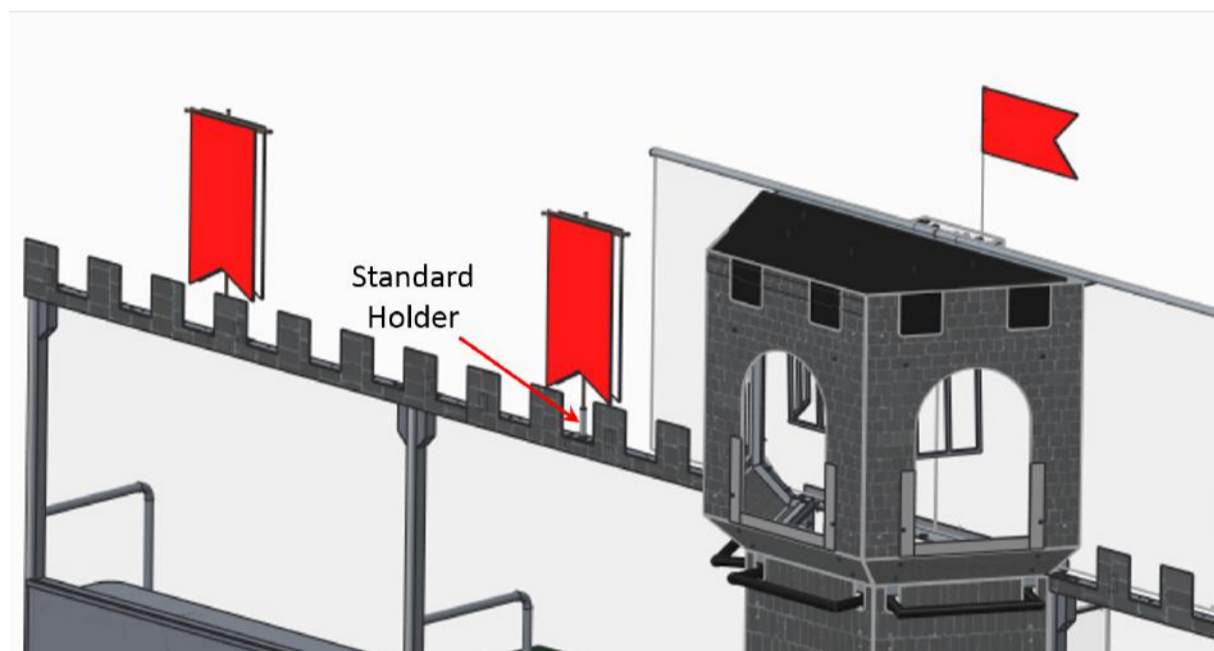

Each PLAYER STATION contains the following electronic components for Teams:

- One Ethernet Cable. This cable attaches to the Ethernet port of the OPERATOR CONSOLE and provides connectivity to the ARENA network.
- One 120VAC NEMA 5-15R power outlet. It is located on the right side of each PLAYER STATION shelf. The outlet is protected by a 3-Amp circuit breaker and can be used to power the OPERATOR CONSOLE. DRIVE TEAMS are responsible for monitoring their power consumption as a tripped breaker in the outlet does not constitute an ARENA fault.
- One Emergency Stop (E-Stop) button. It is located on the left side of the PLAYER STATION shelf and should be used to deactivate a ROBOT if necessary.
- One Team sign. This displays the Team number and is located at the top of each PLAYER STATION.
- One Team LED. This indicates ALLIANCE color, ROBOT status, and E-Stop status and is centered at the top of each PLAYER STATION. Team LED states include:
 - » Solid - indicates that the ROBOT is connected and enabled. This will only happen during a MATCH.
 - » Blinking - indicates that either the Field Management System (FMS) is preset for the MATCH or it's during a MATCH and the corresponding ROBOT has lost connectivity.
 - » Off – indicates that the MATCH has not started yet, but the ROBOT is linked and in a disabled state.

When the amber colored LED is lit, it means that the E-stop button has been pressed.

- One Timer (in the middle PLAYER STATION only). This displays the official time remaining in AUTO, TELEOP, and TIMEOUTS and is marked with white tape along the bottom edge.
- Competition ARENA hardware and wiring. Mostly located below the center PLAYER STATION shelf and TOWER.

HUMAN PLAYER STATION

The HUMAN PLAYER STATION is an area on the side of each CASTLE through which HUMAN PLAYERS feed BOULDERS on to the FIELD. The HUMAN PLAYER STATION connects the PLAYER STATION #1 to the GUARDRAIL. Each HUMAN PLAYER STATION is constructed of a 3 ft. tall diamond plate panel base topped with a 3 ft. 6 in. tall transparent plastic panel.

The BRATTICE is the hole in the HUMAN PLAYER STATION plastic and its protective aluminum cage, which can be used by an ALLIANCE to introduce BOULDERS to the FIELD. The hole is 10-1/2" square, and the bottom edge of the hole is 4 ft. 8 in. from the FIELD carpet. There is a protective aluminum cage that mounts to the polycarbonate on the FIELD side of the CASTLE WALL.

An EMBRASURE is a hole at the bottom of the HUMAN PLAYER STATION wall diamond plate which can be used by an ALLIANCE to introduce BOULDERS to the FIELD. Each HUMAN PLAYER STATION hole has two EMBRASURES, each with an opening of 1 ft. by 1 ft. and a polycarbonate tunnel on the player station side of the hole. These tunnels are 1 ft. 3 in. long, and are designed to help prevent ROBOT to HUMAN PLAYER contact.

For *FIRST* Championship Playoff MATCHES, a 4th Standard Holder will be installed above the Human Player Station, centered over the BRATTICE, to hold the Standard for the ALLIANCE member not listed on the LINEUP for that MATCH.

Figure 2-25: Red HUMAN PLAYER STATION

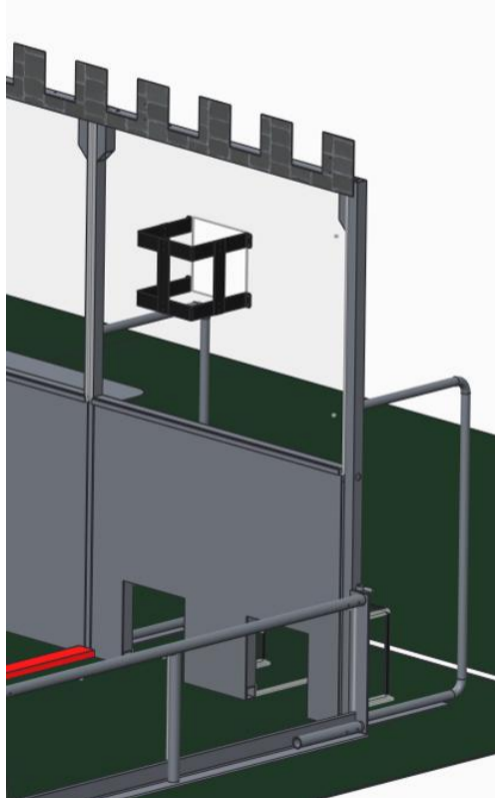
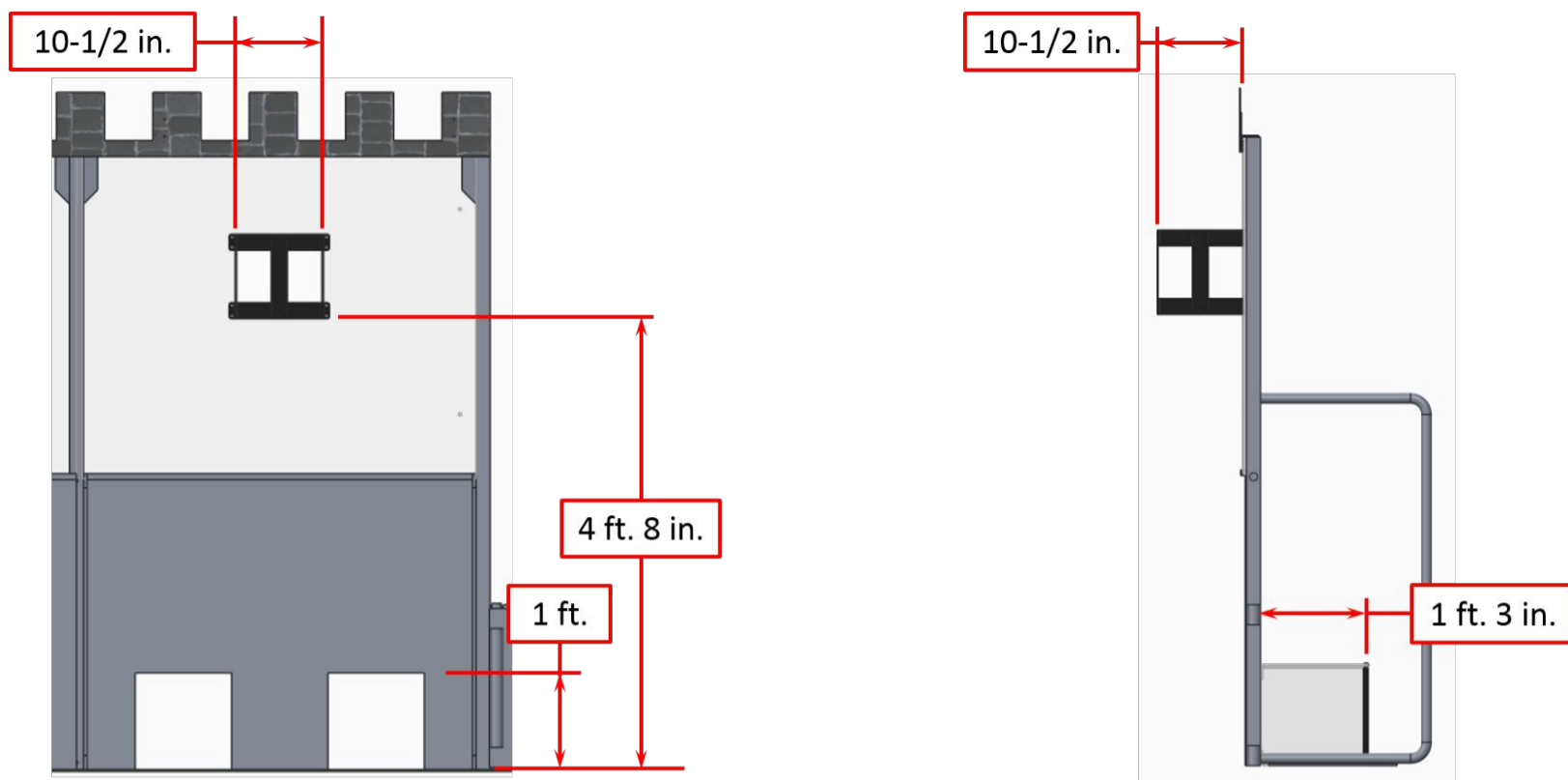

Figure 2-26: HUMAN PLAYER STATION Dimensions



TOWER

Each CASTLE has a TOWER between PLAYER STATIONS one (1) and two (2). Each TOWER has three faces with RUNGS, five GOALS, a BATTER, and a CORRAL.

A set of flags is on top of each TOWER: one red, one blue. Only one flag will be visible at a time. The color of the displayed flag indicates ownership of the TOWER. When a TOWER has been WEAKENED, the flag matching the defending ALLIANCE will be lowered. If at the conclusion of the MATCH a TOWER has been CAPTURED, as described in [Section 3 \(3.1.4 The TOWER\)](#), the flag matching the CAPTURING ALLIANCE color will be raised

Figure 2-27: Flag

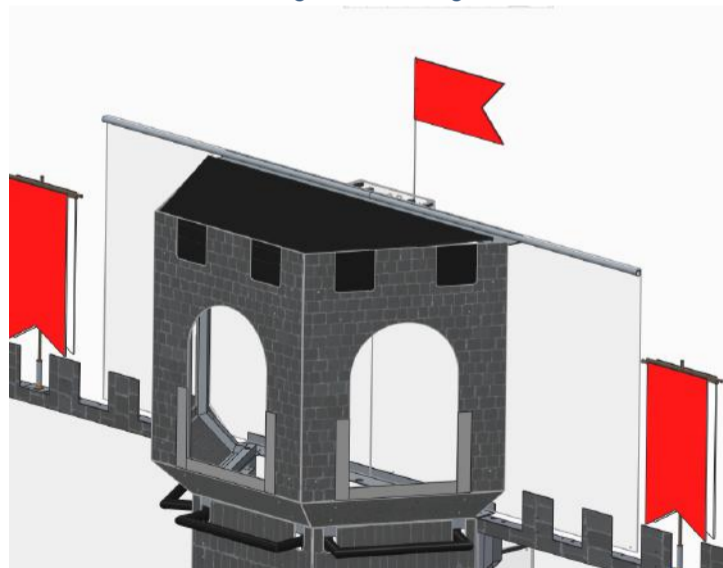

Each TOWER has two (2) Phillips Color Kinetics iColor Flex LMX LED light strings mounted to both vertical edges of the front face of the TOWER. During the MATCH they indicate TOWER STRENGTH. As opponents score BOULDERS in the TOWER, the STRENGTH of the TOWER is reduced and the lights begin to turn off, from the top to the bottom. The lights decrement eight (8) times until the entire strand is off.

Figure 2-28: TOWER STRENGTH Light Location

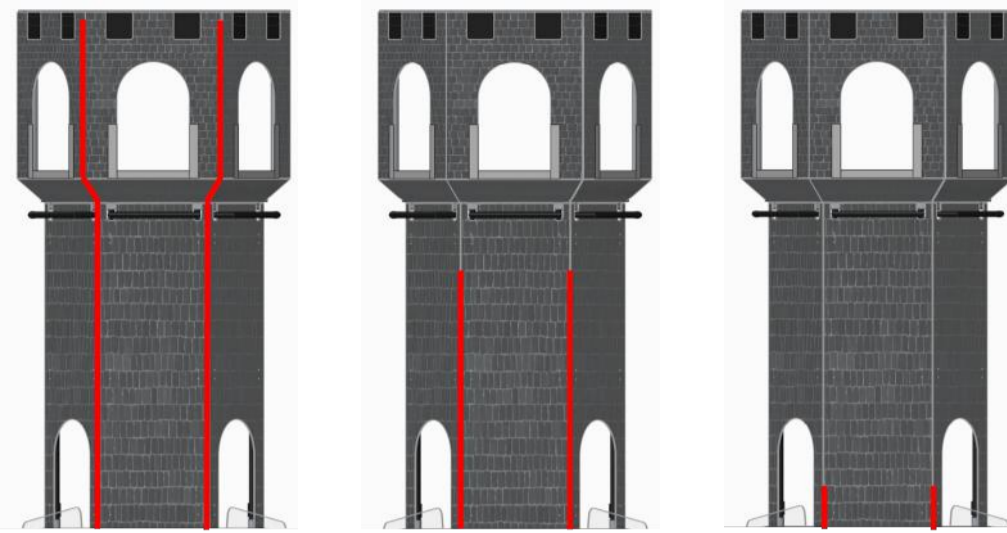

The light strings in the TOWER are used to indicate other situations as well, as shown in [Table 2-2](#).

Table 2-2: TOWER STRENGTH Light States and Meanings

Light State	Meaning
Off	FIELD is ready for the MATCH to begin, all personnel should be off the FIELD at this time. Or Tower has been WEAKENED during a MATCH.
Bottom two-thirds Green	FIELD is safe to enter
Pulsing at 1 Hz for three (3) seconds	The final twenty (20) seconds of the MATCH has begun
Top one-third in opposing ALLIANCE color (Red or Blue)	TOWER has been CAPTURED.

GOALS

Each TOWER has five (5) GOALS; two (2) low and three (3) high. Each GOAL is an opening in the TOWER in which BOULDERS may be scored. Each GOAL is 1 ft. 4 in. wide by 2 ft. tall. The bottoms of the High GOALS are 7 ft. 1 in. from the carpet. The bottoms of the low GOALS are 6 in. from the flat FIELD surface, at the same height as the top of the BATTER.

Each of the high GOALS is marked with two (2) vertical strips of 2 in. retro-reflective material (3M 8830 Silver Marking Film) and one (1) horizontal strip of 2 in. retro-reflective material (with the unsupported .25 in. folded over the bottom edge of the GOAL opening such that 1.75 in. is visible) to form a u-shaped target. The targets are 1 ft. tall and 1 ft. 8 in. wide.

Figure 4-29: High TOWER GOAL Dimensions

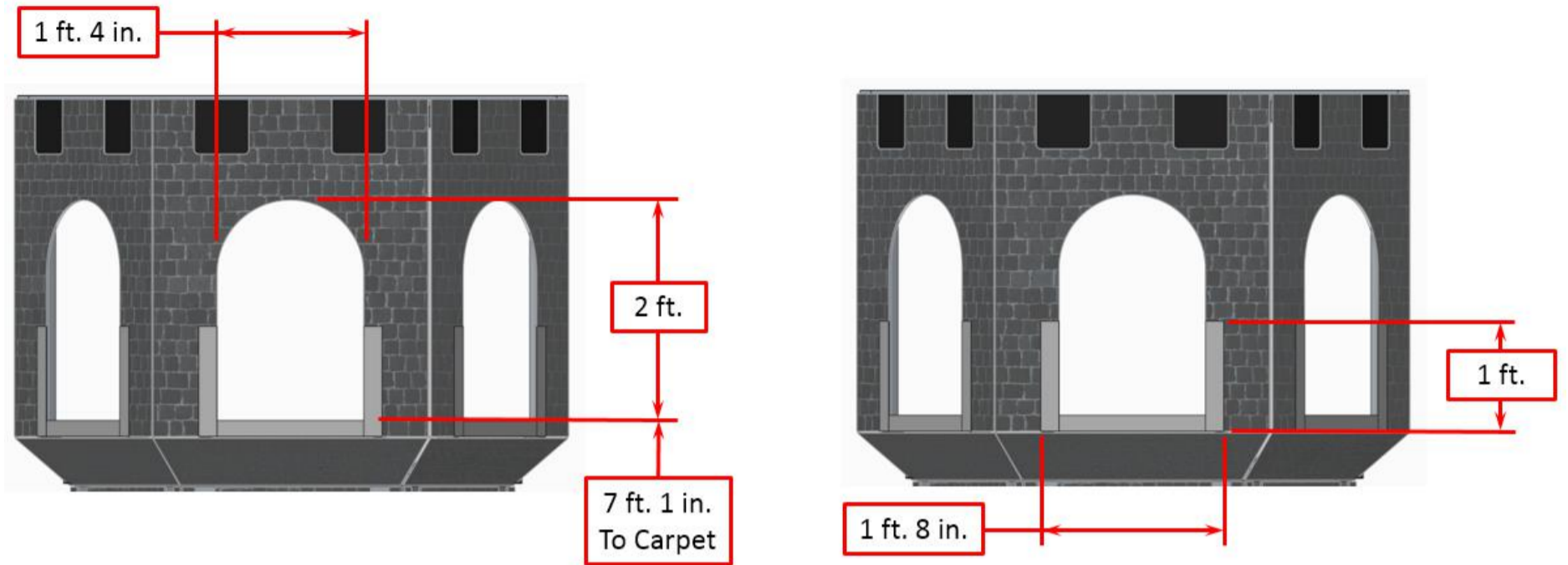
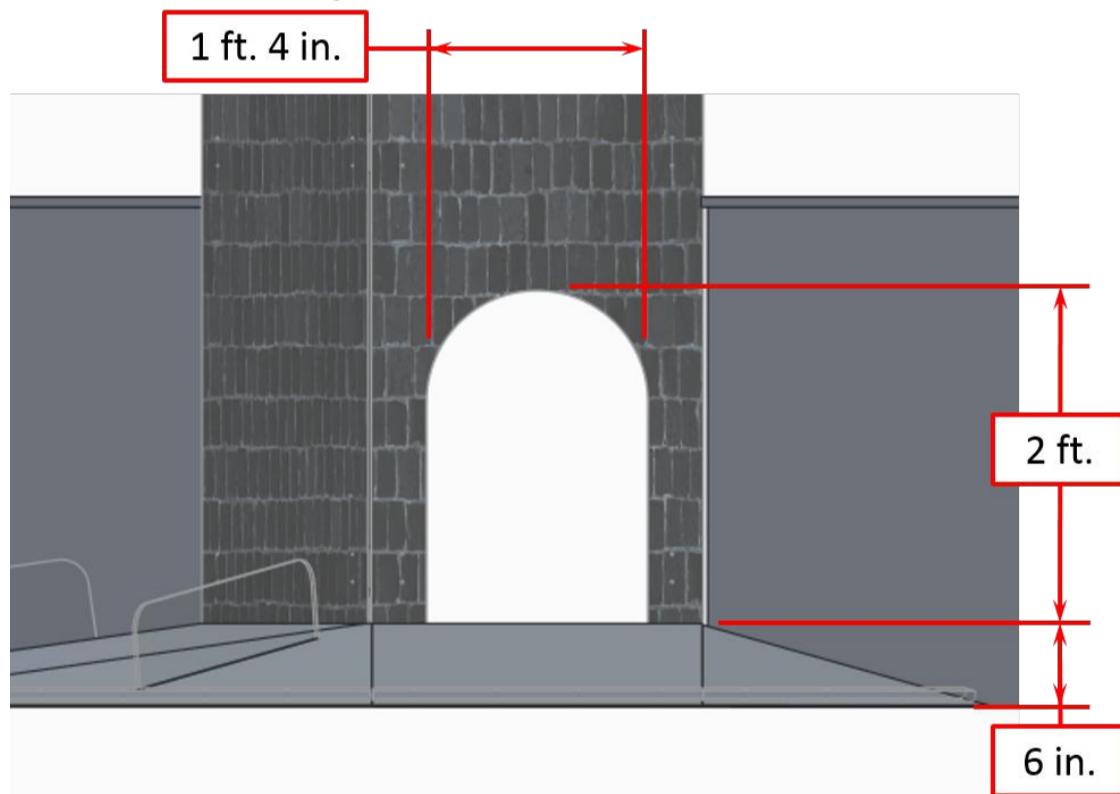
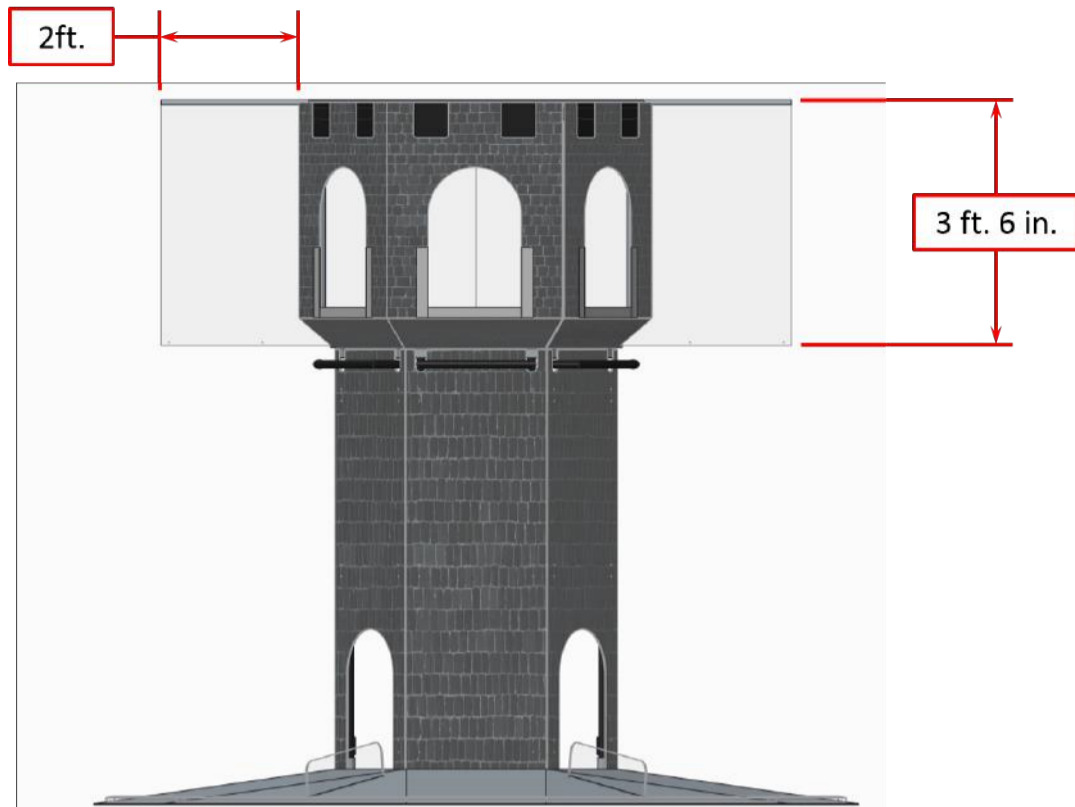

Figure 2-30: Low TOWER GOAL Dimensions



Goals have a series of chains and plastic dividers inside the TOWER to help mitigate shots bouncing out. Details can be found in the [2016 Official FIRST Field Drawings & Models](#). Additionally, each TOWER will have two (2) polycarbonate backboards, hung on either side of the TOWER, to help prevent shots from leaving the FIELD. These backboards are 2 ft. wide and 3 ft. 6 in. tall.

Figure 2-31: TOWER Backboard Size and Location



BATTER

The BATTER is a series of seven (7) ramps with two (2) dividers that create the base of the TOWER. Ramps are 6-8 deg. inclines. The ramps directly in front of the low GOALS are 2 ft. wide and 4 ft. deep. The dividers are clear polycarbonate, 6 in. tall by 26 in. long, located 60 deg. from the face of the CASTLE WALL, and 8 in. from the leading edge of the ramp.

Cleats are attached to the bottoms of the BATTER ramps to help prevent ROBOTS from rolling off the BATTER at the conclusion of the MATCH. They are parallel to and 3-1/2 in. from the bottom edge of each ramp. Cleats are plastic and 3/4 in. tall and 1-1/2 in. deep.

Figure 2-32: BATTER Dimensions and Location

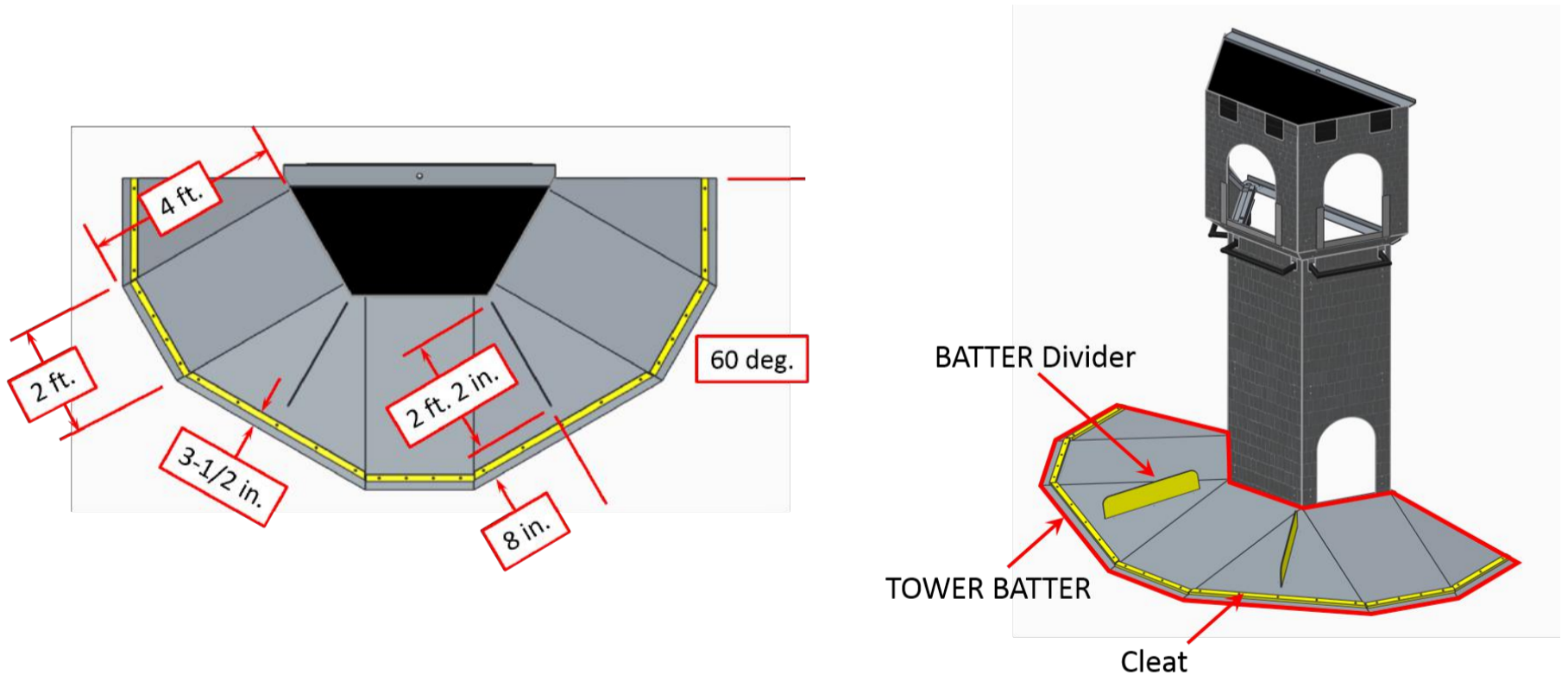

SCALING RUNGS

A RUNG is a bar mounted on a TOWER face that is 1 ft. 9 in. wide and constructed of 1-1/2" Steel DOM Tubing. Each TOWER has three (3) RUNGS, one on each face of the TOWER, designed to support SCALING robots. The top of the rung is 6 ft. 4in. from the FIELD carpet. The RUNGS protrude 5-1/4 in. from the face of the TOWER.

Figure 2-33: TOWER Rung Height and Dimensions

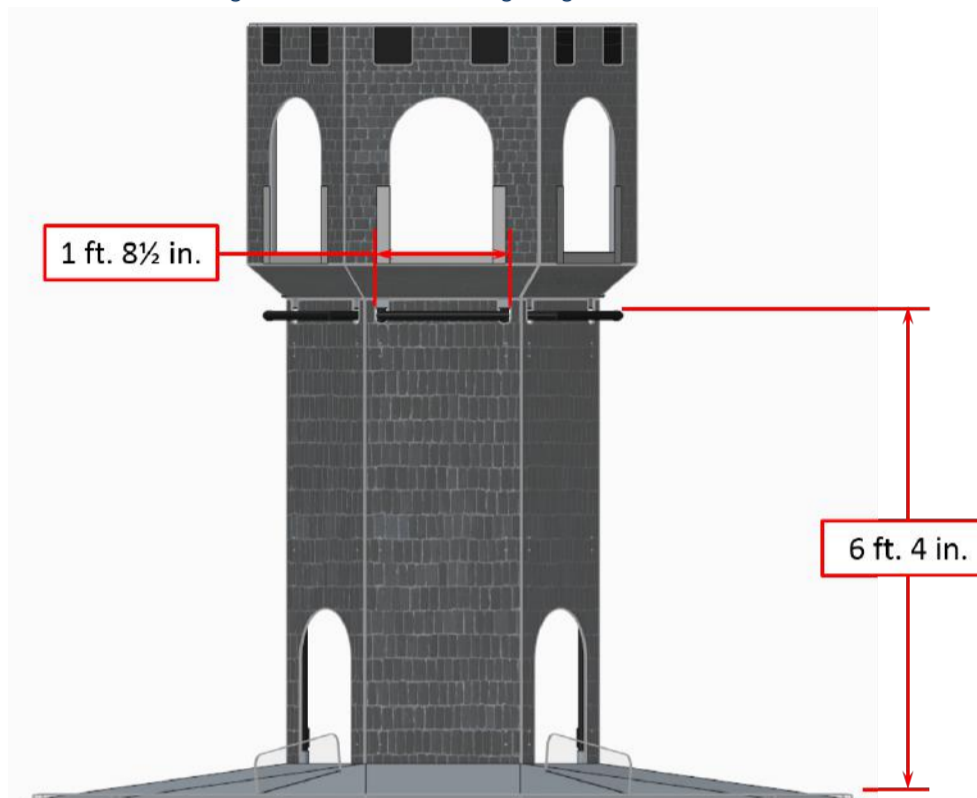

CORRAL

Once a BOULDER passes through the TOWER and is scored, it falls into the CORRAL. The CORRAL is the collection area for scored BOULDERS located at the rear base of the TOWER. The CORRAL is 4 ft. wide, 1 ft. 6 in. tall and extends 2 ft. 11-1/2 in. from the CASTLE WALL.

Figure 2-34: Red CORRAL

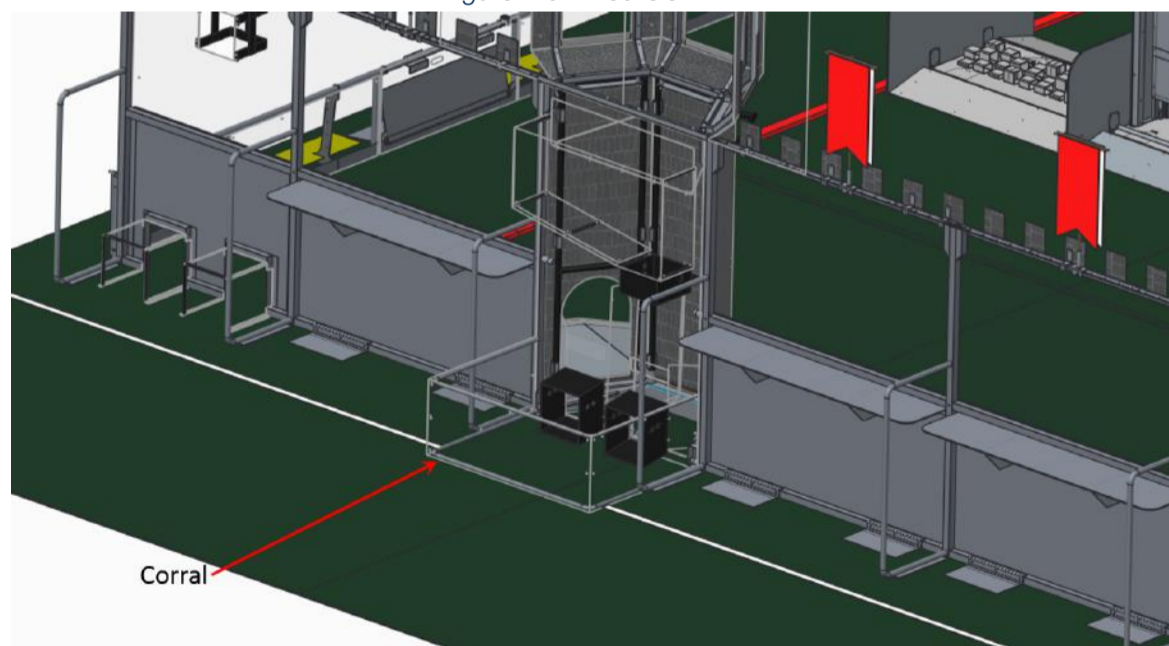

2.3 BOULDERS

Scoring elements are called BOULDERS. BOULDERS are a 10 in. diameter, gray, Gopher SoftiBall™ coated foam ball used by ALLIANCES to score points in *FIRST STRONGHOLD*. BOULDERS may be purchased from [AndyMark](http://AndyMark.com) (AM-3276). Single balls and six (6) packs of rainbow colored balls may be purchased at gophersport.com (6-pack Item Number: 47-121, Single ball Item Number: 99-634).

Figure 2-35: BOULDER



Each MATCH begins with eighteen (18) BOULDERS in the ARENA. BOULDERS are staged before the MATCH in the following manner:

- A. Six (6) BOULDERS are staged evenly along the length of the Midline, 3 ft. 9-1/2 in. apart as shown in Figure 2-35. Small rings are used to keep them in place prior to the start of a MATCH. Rings are O-rings, Dash 222, Buna N, 1.762 in. outer diameter, .13 in thick (Grainger Item#: 1KLE7). Rings will be secured to the carpet by the MIDLINE tape.
- B. Three (3) BOULDERS are staged in each CASTLE
- C. Three (3) BOULDERS per ALLIANCE are staged on or in each ROBOT or in the CASTLE. See [Section 3 \(3.2 MATCH Logistics\)](#) for more detail.

Figure 2-36: Standard Holder

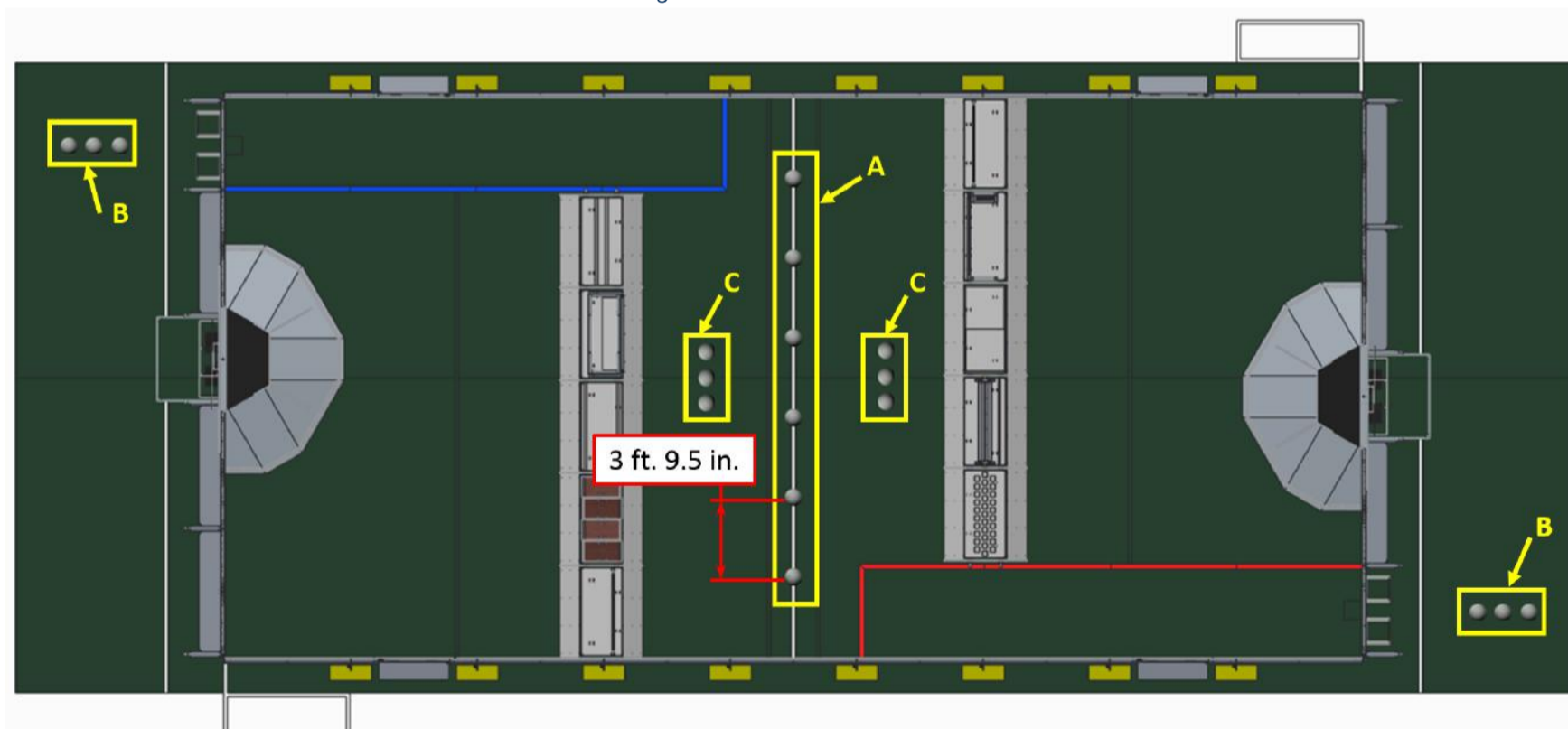

2.4 The FIELD Management System

When a DRIVE TEAM connects the Ethernet cable from their assigned PLAYER STATION to their OPERATOR CONSOLE, the Driver Station software on the OPERATOR CONSOLE computer will begin to communicate with the FIELD Management System (FMS). Once connected to FMS, ports are available are as follows:

- A. TCP 1180: Camera data from the roboRIO to the Driver Station (DS) when the camera is connected the roboRIO via USB, bi-directional.
- B. TCP 1735: SmartDashboard, bi-directional
- C. UDP 1130: Dashboard-to-ROBOT control data, uni-directional
- D. UDP 1140: ROBOT-to-Dashboard status data, uni-directional
- E. HTTP 80: Camera connected via switch on the ROBOT, bi-directional
- F. HTTP 443: Camera connected via switch on the ROBOT, bi-directional
- G. UDP/TCP 554: Real-Time Streaming Protocol for h.264 camera streaming, bi-directional
- H. UDP/TCP 5800-5810: Team Use, bi-directional

Teams may use these ports as they wish if they do not employ them as outlined above (i.e. TCP 1180 can be used to pass data back and forth between the ROBOT and the Driver Station if the Team chooses not to use the camera on USB). Additional information about the FMS may be found on the *FIRST* website in the FMS Whitepaper.

FIRST®, the *FIRST*® logo, *FIRST*® Robotics Competition, FRC®, Coopertition®, Gracious Professionalism® are registered trademarks, and Sport for the Mind™ and *FIRST* STRONGHOLDSM are common law trademarks, of the United States Foundation for Inspiration and Recognition of Science and Technology (*FIRST*®). ©2015 *FIRST*. All rights reserved.

3

Game

3.1 MATCH Play	3
3.1.1 DRIVE TEAM	3
3.1.2 MATCH Timing.....	3
3.1.3 DEFENSES and the OUTER WORKS	3
3.1.4 The TOWER.....	4
3.2 MATCH Logistics	5
3.3 Scoring	5
3.3.1 Point Values.....	6
3.3.2 Penalty Assignment.....	6
3.4 Rules	7
3.4.1 Safety Rules	7
3.4.2 Pre and Post-MATCH	8
3.4.3 General Rules	9
3.4.4 AUTO Rules	10
3.4.5 ROBOT Rules	11

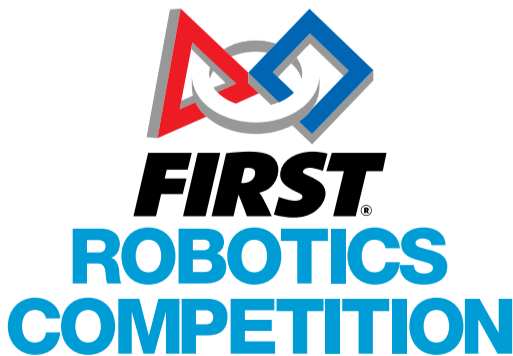

FIRST®, the *FIRST*® logo, *FIRST*® Robotics Competition, *Coopertition*®, *Gracious Professionalism*®, and *Sport for the Mind*™ are trademarks of the United States Foundation for Inspiration and Recognition of Science and Technology (*FIRST*®). © 2015-2016 *FIRST*. All rights reserved.

Official *FIRST*® Robotics Competition teams and Partners are permitted to make reproductions of this manual for team and Partner use only. Any use, reproduction, or duplication of this manual for purposes other than directly by the team or Partner as part of *FIRST*® Robotics Competition participation is strictly prohibited without specific written permission from *FIRST*.

3

Game

3.4.6	ROBOT to ROBOT Interaction.....	12
3.4.7	ROBOT Gameplay	14
3.4.8	Human Actions.....	14
3.4.9	BOULDER Rules.....	16
3.4.10	DEFENSE Rules.....	18

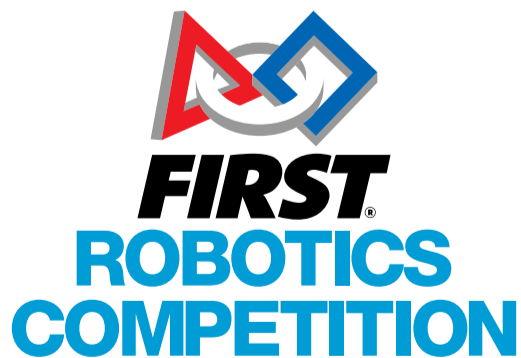

FIRST[®], the *FIRST*[®] logo, *FIRST*[®] Robotics Competition, *Coopertition*[®], *Gracious Professionalism*[®], and *Sport for the Mind*[™] are trademarks of the United States Foundation for Inspiration and Recognition of Science and Technology (*FIRST*[®]). © 2015-2016 *FIRST*. All rights reserved.

Official *FIRST*[®] Robotics Competition teams and Partners are permitted to make reproductions of this manual for team and Partner use only. Any use, reproduction, or duplication of this manual for purposes other than directly by the team or Partner as part of *FIRST*[®] Robotics Competition participation is strictly prohibited without specific written permission from *FIRST*.

3 GAME

*FIRST STRONGHOLD*SM is a medieval tower defender game in which two (2) ALLIANCES of three (3) Teams each select DEFENSES to fortify their OUTER WORKS before competing simultaneously to score points while BREACHING the opponent's OUTER WORKS and CAPTURING the opponent's TOWER.

This chapter contains four sections: the first two describe the setup and play of the game, the third contains the point values for accomplishments, and the final section describes the detailed rules by which competitors must abide.

The *FIRST STRONGHOLD* manual is originally written in English, but is occasionally translated into other languages for the benefit of *FIRST* Robotics Competition Teams whose native language may not be English. In the event that a translation of a rule or description changes its meaning, it shall be enforced according to the English definition, as originally written.

3.1 MATCH Play

Details regarding MATCH timing and the process by which the OUTER WORKS are BREACHED and TOWERS are CAPTURED are defined in this section.

3.1.1 DRIVE TEAM

Each Team competing in a MATCH (collectively known as the DRIVE TEAM) is composed of a maximum of four (4) persons consisting of:

- Two (2) DRIVERS, pre-college students who are primarily responsible for ROBOT operation,
- One (1) HUMAN PLAYER, a pre-college student who is primarily responsible for Game Piece management, and
- One (1) COACH, who is identified as the person wearing the designated "COACH" pin or button

3.1.2 MATCH Timing

Each MATCH is two (2) minutes and thirty (30) seconds long. The Autonomous Period (AUTO) is the first fifteen (15) seconds of the MATCH in which ROBOTS operate without any DRIVE TEAM control or input. The Teleoperated Period (TELEOP) is the remaining two (2) minutes and fifteen (15) seconds of a MATCH in which ROBOTS may be directly controlled by DRIVERS and/or HUMAN PLAYERS.

3.1.3 DEFENSES and the OUTER WORKS

The OUTER WORKS impede the passage of ROBOTS and BOULDERS into the COURTYARD. ROBOTS move BOULDERS across the OUTER WORKS into the COURTYARD one-at-a-time.

Each DEFENSE starts the MATCH with two (2) STRENGTH (a measure of progress towards the completion of an objective). Each time a DEFENSE is CROSSED by a ROBOT, its STRENGTH is decreased by one (1). When a DEFENSE'S STRENGTH reaches zero (0), the DEFENSE is DAMAGED. The STRENGTH of a DEFENSE is indicated by DEFENSE lighting as described in [Section 2 \(2.2.2.1 DEFENSES\)](#). Once four (4) out of an ALLIANCE'S five (5) DEFENSES have been DAMAGED, the ALLIANCE'S OUTER WORKS are BREACHED.

A DEFENSE is CROSSED by a ROBOT when that ROBOT

- starts free of contact with the DEFENSE and completely in the NEUTRAL ZONE
- traverses the DEFENSE such that its BUMPERS go fully between the adjacent SHIELDS/GUARDRAIL, and
- ends up fully contained by the opponent's COURTYARD.

ROBOTS can also receive AUTO points for REACHING a DEFENSE. A DEFENSE is REACHED when, at the end of the AUTO period, any part of a ROBOT's BUMPERS are within the opponent's OUTER WORKS. Once a ROBOT CROSSES a DEFENSE in AUTO, any additional REACHES or CROSSES by that ROBOT during the AUTO period will not decrease DEFENSE STRENGTH nor contribute points to the ALLIANCE.

If it is unclear whether a ROBOT has satisfied the requirements for CROSSING or REACHING a DEFENSE, the REFEREES are instructed to not award credit. As such, DRIVE TEAMS should make it very clear that their ROBOT has met the criteria for CROSSING or REACHING a DEFENSE.

A BREACH of the opposing ALLIANCE'S OUTER WORKS earns the ALLIANCE one (1) Ranking Point during Qualification MATCHES (see [Section 5 \(5.3.3 Ranking Score \(RS\)\)](#)) or match points during Playoff MATCHES.

3.1.4 The TOWER

A BOULDER is scored in a GOAL if it passes through the opening of a GOAL and exits into the CORRAL, and the points awarded for that BOULDER are assigned based on when the BOULDER passed through the opening of the GOAL.

If a BOULDER becomes jammed in the TOWER, credit for the jammed BOULDER(S) will be granted in the period in which the BOULDER(S) became stuck.

Each TOWER starts the MATCH with ten (10) STRENGTH. Each BOULDER scored in a GOAL decreases the TOWER'S STRENGTH by one (1). A TOWER is WEAKENED if the TOWER'S STRENGTH is at or below zero (0). The STRENGTH of a TOWER is indicated by TOWER lighting as described in [Section 2 \(TOWER\)](#).

As the season progresses, TOWERS may become fortified to increase their starting STRENGTH. While the starting STRENGTH of a TOWER will not change between weeks of Regional or District Competition play, the starting STRENGTH of a TOWER may be changed for District Championship and/or FIRST Championship play. Teams will be notified of changes in the starting STRENGTH of a TOWER no later than the scheduled Team Update prior to the date of the event.

A ROBOT has CHALLENGED the TOWER if, at the conclusion of the MATCH, the ROBOT is fully supported by the TOWER, but hasn't met the criteria for SCALING the TOWER.

Support is transitive through other objects. For example, if a BOULDER is fully supported by the BATTER, and a ROBOT is supported only by the BATTER and the BOULDER, the ROBOT is still considered fully supported by the TOWER.

A ROBOT has SCALED the TOWER if, at the conclusion of the MATCH, the ROBOT:

- A. is in contact with a unique RUNG, and
- B. has all of its BUMPERS fully above the height of the low GOALS.

The GOAL openings are not designed to be weight bearing surfaces. Using these elements to SCALE the TOWER is not only in violation of G12, but is also subject to an additional YELLOW CARD for egregious ROBOT behavior as described in the final paragraph of [Section 3.3.2 Penalty Assignment](#).

A TOWER is CAPTURED if, at the conclusion of the MATCH:

- A. the TOWER is WEAKENED, and
- B. the TOWER is surrounded such that each of the three (3) opponent ROBOTS has SCALED or CHALLENGED a unique face of the TOWER

A ROBOT has SCALED or CHALLENGED a unique face of the TOWER if it is the only ROBOT in contact with the attached RUNG and/or associated third of the BATTER below (i.e. a ROBOT may extend over the divider into the space of another face as long as it is not in contact with the RUNG or BATTER in front of that face).

CAPTURING the opponent's TOWER earns the ALLIANCE one (1) Ranking Point during Qualification MATCHES (see [Section 5 \(5.3.3 Ranking Score \(RS\)\)](#)) or MATCH points during Playoff MATCHES.

3.2 MATCH Logistics

When a DRIVE TEAM loads their ROBOT onto the FIELD for a MATCH they may elect to:

- A. pre-load one (1) BOULDER in or on their ROBOT such that the BOULDER is fully supported by their ROBOT, or
- B. transfer their BOULDER to a HUMAN PLAYER in their CASTLE.

BOULDERS that exit the FIELD over a GUARDRAIL during a MATCH are placed back into the FIELD approximately at the point of exit by FIELD STEWARDS (REFEREES, FTAs, or other staff working around the FIELD) at the earliest safe opportunity. BOULDERS that exit the FIELD over a CASTLE WALL during a MATCH are returned to the COURTYARD at the corner of the GUARDRAIL and CASTLE by FIELD STEWARDS at the earliest safe opportunity. BOULDERS that exit the FIELD through the CASTLE (including the holes in the HUMAN PLAYER STATION) belong to the ALLIANCE.

Note that ROBOTS may not deliberately cause BOULDERS to leave the FIELD (see [G42](#)).

If a BOULDER becomes stuck within the TOWER, FIELD STEWARDS will free the BOULDERS at the earliest safe opportunity. Damaged BOULDERS will not be replaced until the next FIELD reset period. DRIVE TEAMS should alert the FIELD STEWARDS to any damaged BOULDERS prior to the start of the MATCH. There will not be an ARENA fault called for MATCHES that accidentally begin with damaged game elements.

3.3 Scoring

During AUTO, points are earned by ROBOTS that REACH or CROSS a DEFENSE and score BOULDERS in GOALS. During TELEOP, points are earned by ROBOTS CROSSING undamaged DEFENSES, scoring BOULDERS in GOALS, and CHALLENGING or SCALING the opponent's TOWER.

3.3.1 Point Values

Point values for the tasks in *FIRST STRONGHOLD* are detailed in [Table 3-1: Point Values](#).

Table 3-1: Point Values

Action	AUTO	TELEOP	Qual.	Playoff
REACHING a DEFENSE	2	-	-	-
CROSSING an UNDAMAGED DEFENSE	10	5	-	-
BOULDER in Low TOWER GOAL	5	2	-	-
BOULDER in High TOWER GOAL	10	5	-	-
CHALLENGE (per ROBOT)	-	5	-	-
SCALE (per ROBOT)	-	15	-	-
BREACH	-	-	1 RP	20
CAPTURE	-	-	1 RP	25

All scores are assessed and updated throughout the MATCH.

The final assessment of BOULDERS scored in GOALS is made five (5) seconds after the ARENA timer displays zero (0) following TELEOP.

The final assessment of ROBOTS having SCALED or CHALLENGED the TOWER is made five (5) seconds after the ARENA timer displays zero (0), or when all ROBOTS have come to rest following the conclusion of the MATCH, whichever happens first.

3.3.2 Penalty Assignment

Upon a rule violation, one or more of the penalties listed in [Table 3-2: Penalties](#) will be assessed.

Table 3-2: Penalties

Action	Penalty
FOUL	5 points credited towards the opponent's total score.
TECH FOUL	FOUL + STRENGTH of opponent's TOWER is increased by one (1)
YELLOW CARD	A warning issued by the Head REFEREE for egregious ROBOT or <i>FIRST</i> Robotics Competition Team member behavior or repeated rule violations. A subsequent YELLOW CARD within the same tournament phase will lead to a RED CARD.
RED CARD	A penalty assessed for egregious ROBOT or <i>FIRST</i> Robotics Competition Team member behavior, or repeated rule violations, which results in a Team being DISQUALIFIED for the MATCH.
DISABLED	ROBOT will be commanded to deactivate all outputs, rendering the ROBOT inoperable for the remainder of the MATCH.

Although the FIELD lights will only show a maximum STRENGTH equal to the starting STRENGTH and a minimum STRENGTH equal to zero, there is no maximum or minimum STRENGTH for a TOWER.

For example, if a Red ROBOT violates a rule that results in the ALLIANCE'S first TECH FOUL, but the Blue TOWER has not yet been scored upon, the Blue TOWER'S STRENGTH will be nine (9), one (1) higher than indicated by the FIELD lights.

In addition to rule violations explicitly listed in [Section 3.4 Rules](#), the Head REFEREE may assign a YELLOW or RED CARD as a result of egregious ROBOT actions or Team member behavior at the event, per [Section 5 \(5.5.4 YELLOW and RED CARDS\)](#).

3.4 Rules

The rules in this section legislate game play and define the consequences for rule violations as enforced by the REFEREES.

3.4.1 Safety Rules

G1 ROBOTS whose operation or design is dangerous or unsafe are not permitted.

Violation: If before the MATCH, the offending ROBOT will not be allowed to participate in the MATCH. If during the MATCH, the offending ROBOT will be DISABLED.

Examples include, but are not limited to:

- A. Uncontrolled motion that cannot be stopped by the DRIVE TEAM
- B. ROBOT parts “flailing” outside of the FIELD
- C. ROBOTS dragging their battery
- D. ROBOTS that consistently extend beyond the FIELD

G2 DRIVE TEAMS may only enter the FIELD if the TOWER LED strings are green, unless explicitly instructed by a REFEREE or an FTA.

Violation: YELLOW CARD

G3 ROBOTS and anything they control, e.g. a BOULDER, may not contact anything outside the FIELD with the exception of brief incursions into the GOALS.

Violation: Offending ROBOT will be DISABLED

Please be conscious of SPIES, REFEREES, and FIELD STEWARDS working around the ARENA who may be in close proximity to your ROBOT.

G4 DRIVE TEAMS may not extend any body part into the FIELD during the MATCH. Momentary encroachment through the hole in the HUMAN PLAYER STATION behind the BRATTICE while placing a BOULDER into that hole is an exception to this rule.

Violation: FOUL. Violations of this rule are likely to escalate to YELLOW or RED CARDS rapidly (i.e. the threshold for egregious or repeated violations is relatively low)

Examples of egregious violations include, but are not limited to, walking onto the FIELD during a MATCH or intentionally reaching into the FIELD and grabbing a ROBOT during a MATCH.

G5 DRIVE TEAMS may not climb over, step over, or walk over/across DEFENSES or PLATFORMS, with the exception that teams may carefully step on DEFENSES or PLATFORMS in order to remove the robot from the DEFENSE.

Violation: YELLOW CARD

G6 DRIVE TEAMS may only enter or exit the FIELD through open gates.

Violation: YELLOW CARD

3.4.2 Pre and Post-MATCH

G7 When placed on the FIELD for a MATCH, each ROBOT must be:

- A. in compliance with all ROBOT rules, i.e. has passed Inspection (for exceptions regarding Practice MATCHES, see [Section 5 \(5.5.2 Eligibility and Inspection\)](#)),
- B. not in contact with a BOULDER staged on the MIDLINE,
- C. the only item left on the FIELD by the DRIVE TEAM,
- D. confined to its STARTING CONFIGURATION,
- E. fully contained by the opposite half of the FIELD from their TOWER, and
 - i. breaking the plane of the AUTO LINE, or
 - ii. inside the COURTYARD, in contact with both the CASTLE WALL and GUARDRAIL. Only one (1) ROBOT per ALLIANCE, known as the “spy bot,” is allowed to start each MATCH in this position.

Violation: If fix is a quick remedy, the MATCH won't start until all requirements are met. If it is not a quick remedy the offending ROBOT will be DISABLED and, at the discretion of the Head REFEREE, must be re-inspected.

If a ROBOT is BYPASSED prior to the start of the MATCH, the DRIVE TEAM may not remove the ROBOT from the FIELD without permission from the Head REFEREE or the *FIRST* Technical Advisor (FTA).

G8 DRIVE TEAMS may not cause significant or repeated delays to the start of a MATCH and/or to the FIELD reset at the conclusion of the MATCH.

Violation: If prior to the MATCH, the offending DRIVE TEAM'S ROBOT will be DISABLED. If after the MATCH, YELLOW CARD

DRIVE TEAMS are expected to stage their ROBOTS for a MATCH, and remove it from the FIELD afterwards, safely and swiftly. DRIVE TEAM efforts that either intentionally or unintentionally delay the start of a MATCH or the FIELD reset are not allowed. Examples include, but are not limited to:

- A. Late arrival to the FIELD
- B. Failing to exit the FIELD once the TOWER LED strings have turned off (indicating MATCH ready)
- C. Installing bumpers, charging pneumatic systems, or any other ROBOT maintenance, once on the FIELD
- D. Use of alignment devices that are external to the ROBOT
- E. Failing to remove OPERATING CONSOLES from the PLAYER STATIONS in a timely manner

G9 DRIVE TEAMS must be in their CASTLE and behind the STARTING LINE prior to the start of the MATCH, with the exception of one (1) DRIVER or HUMAN PLAYER per ALLIANCE who may elect to start in the SPY BOX as outlined in [Section 2 \(2.1 Zones & Markings\)](#).

Violation: MATCH will not start until the situation is corrected

G10 ROBOTS will not be re-enabled after the conclusion of the MATCH, nor will Teams be permitted to tether to the ROBOT except in special circumstances (e.g. during TIMEOUTS, after Opening Ceremonies, etc.) and with the express permission from the FTA or a REFEREE.

Violation: YELLOW CARD

Tethering includes any wired or wireless connection used to electrically energize and/or control elements on the ROBOT. The safety of Teams and FIELD STEWARDS in close proximity to ROBOTS and ARENA elements on the FIELD is of the utmost importance, therefore ROBOTS or ROBOT COMPONENTS may not be energized or powered in any way on the FIELD once the match has concluded.

3.4.3 General Rules

G11 Strategies aimed solely at forcing the opposing ALLIANCE to violate a rule are not in the spirit of FIRST Robotics Competition and not allowed. Rule violations forced in this manner will not result in an assignment of a penalty to the targeted ALLIANCE.

Violation: FOUL. If egregious or repeated, YELLOW CARD

G11 does not apply for strategies consistent with standard gameplay, e.g. a TEAM obtaining a BOULDER from their SECRET PASSAGE, CROSSING an opponent DEFENSE, etc. G11 requires an intentional act with limited or no opportunity for the TEAM being acted on to avoid the penalty. Examples include:

- A. A Blue ROBOT, with twenty (20) seconds left in the MATCH, is parked in front of the middle face of the Blue TOWER. A Red ROBOT, attempting to SCALE that face, runs into the blocking Blue ROBOT. This results in a violation of G28 by the Blue ROBOT. Because the Red ROBOT was not solely making an attempt to cause that Blue ROBOT to violate G28, but rather to complete a Game Action (a SCALE), they are not in violation of G11.
- B. A Red ROBOT is parked in the NEUTRAL ZONE near the Blue SECRET PASSAGE. A Blue ROBOT pushes the Red ROBOT into the Blue SECRET PASSAGE, then drives away. There is no violation of G21 by the Red ROBOT, as the Red ROBOT was forced by the Blue ROBOT into the SECRET PASSAGE. The Blue ROBOT has violated G11 by forcing the Red ROBOT into the SECRET PASSAGE for the sole purpose of causing them to violate G21.
- C. A Red ROBOT is parked completely within the Blue SECRET PASSAGE. A Blue ROBOT, attempting to reach the Blue BRATTICE, makes contact with the Red ROBOT. The Red ROBOT receives a G21 penalty. There are no violations of G11 because the Blue ROBOT was trying to access their BRATTICE and not solely trying to cause the Red ROBOT to violate G21.

G12 The following actions are prohibited with regards to interaction with ARENA elements (item C excludes use of the PLAYER STATION hook-and-loop tape, plugging in to the provided power outlet, and plugging the provided Ethernet cable in to the Driver Station computer and items A-E exclude any DEFENSE, opponent's RUNGS, and BOULDERS)

- A. Grabbing
- B. Grasping
- C. Attaching to (including the use of hook-and-loop tape against the FIELD carpet)
- D. Grappling
- E. Hanging
- F. Becoming entangled
- G. Damaging

Violation: If prior to MATCH, and situation can be corrected quickly, it must be remedied before the MATCH will start. If during a MATCH, FOUL. If during a MATCH and extended or repeated, YELLOW CARD. If offense is via a ROBOT and the Head REFEREE determines that further damage is likely to occur, offending ROBOT will be DISABLED. Corrective action (such as eliminating sharp edges, removing the damaging MECHANISM, and/or re-Inspection) may be required before the ROBOT will be allowed to compete in subsequent MATCHES.

BOULDERS are expected to undergo a reasonable amount of wear and tear as they are handled by ROBOTS, such as scratching or marking. Gouging, tearing off pieces, or routinely marking BOULDERS will be considered in violation of this rule. Humans causing BOULDER wear and tear, e.g. cracking a BOULDER coating, are subject to a CARD per [Section 5 \(5.5.4 YELLOW and RED CARDS\)](#).

G12-1 ROBOTS may not deliberately use FIELD elements, e.g. BOULDERS, in an attempt to ease or amplify the challenge associated with other FIELD elements, e.g. DEFENSES.

Violation: FOUL. For every five (5) seconds in which the situation is not corrected, FOUL

Example actions that violate G12-1 include, but aren't limited to the following: adding BOULDERS to your Moat to make it harder for your opponents to CROSS the Moat, using a BOULDER to prop up Cheval de Frise elements, propping open a DEFENSE door with a BOULDER.

3.4.4 AUTO Rules

G13 During AUTO, ROBOTS may not enter the volume above the MIDLINE.

Violation: FOUL. If contact is made with an opponent ROBOT beyond the MIDLINE (either direct contact or transitive contact through a BOULDER), an additional FOUL is assessed and the opponent ROBOT is immediately awarded the CROSSING of the closest DEFENSE from the point of contact.

G14 During AUTO, DRIVE TEAMS may not directly or indirectly interact with ROBOTS or OPERATOR CONSOLES unless for personal safety, OPERATOR CONSOLE safety, or pressing an E-Stop for ROBOT safety.

Violation: FOUL and YELLOW CARD

- G15** During AUTO, DRIVE TEAM members in the CASTLE may not contact anything in front of the STARTING LINE, unless for personal or equipment safety.

Violation: FOUL

Pointing, gesturing or otherwise extending across the STARTING LINE such that contact is not made with carpet or other ARENA elements is not a violation of this rule.

- G16** Any control devices worn or held by the DRIVERS and/or HUMAN PLAYERS during AUTO must be disconnected from the OPERATOR CONSOLE.

Violation: FOUL

3.4.5 ROBOT Rules

- G17** ROBOT height, as measured when it's resting normally on a flat floor, may not exceed 4 ft. 6 in. during the MATCH, except during the final twenty (20) seconds of TELEOP where there is no height limit when a ROBOT is fully contained by the opponent's COURTYARD.

Violation: FOUL. If strategic, offending ROBOT will be DISABLED.

This measurement is intended to be made as if the ROBOT is resting on a flat floor, not relative to the height of the ROBOT from the FIELD carpet.

For example, a ROBOT that is at an angle while traversing a DEFENSE may actually exceed the height limit when compared to the carpet of the FIELD.

Figure 3-1: ROBOT Height

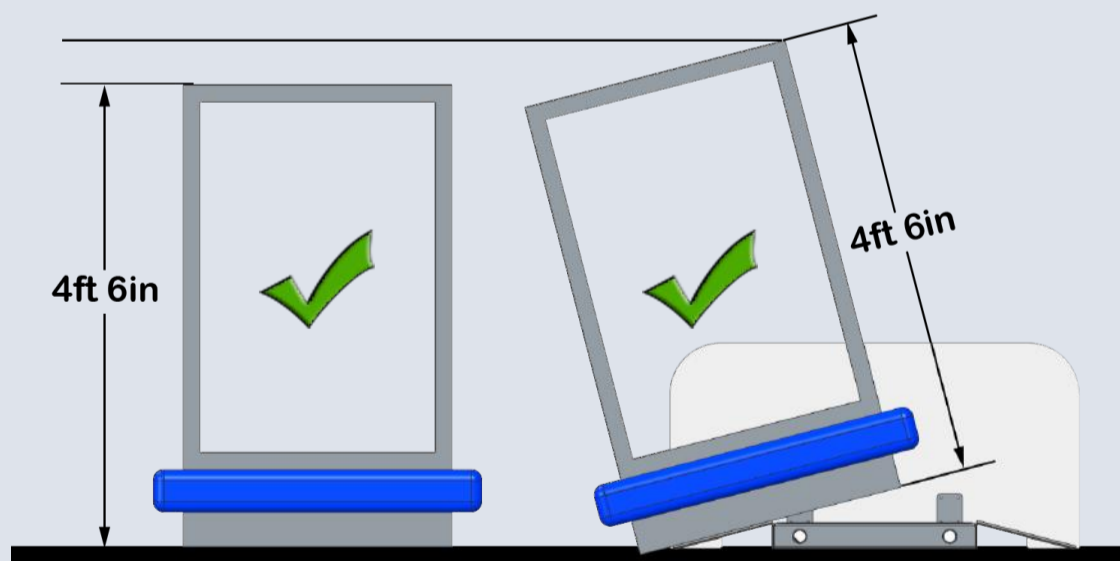

Teams should be mindful of safety if designing their ROBOTS to extend beyond the height of the CASTLE WALL.

- G18** ROBOTS may not extend more than 15 in. beyond their FRAME PERIMETER.
Violation: FOUL. If repeated, offending ROBOT will be DISABLED.

Examples of compliance and non-compliance of G18 are shown in [Figure 3-2](#).

Yellow bars represent the measurement of the FRAME PERIMETER and are drawn in the same orientation of the ROBOT'S FRAME PERIMETER. Green bars represent a measured extension from the FRAME PERIMETER that has not been exceeded. Red bars represent a measured extension from the FRAME PERIMETER that has been exceeded (violating [G18](#)). ROBOTS A and C violate [G18](#), whereas ROBOT B does not.

Figure 3-2: Examples of G18 compliance and non-compliance.

- G19** ROBOTS may not intentionally detach or leave parts on the FIELD.
Violation: RED CARD

This rule is not intended to penalize ROBOTS that encounter accidental breakage (e.g. a failed MECHANISM that falls off), as those actions are not intentional.

- G19-1** ROBOTS must be in compliance with [Section 4 \(4.7 BUMPER Rules\)](#) throughout the MATCH.
Violation: FOUL. DISABLED if structurally non-compliant or the Team number or ALLIANCE color is ambiguous.

3.4.6 ROBOT to ROBOT Interaction

- G20** ROBOTS may only enter or exit their opponent's SECRET PASSAGE from/to the opponent's COURTYARD. A ROBOT is considered to be within the SECRET PASSAGE once the only carpet the ROBOT is in contact with is the carpet inside the SECRET PASSAGE.
Violation: FOUL. If repeated, TECH FOUL
- G21** A ROBOT contacting carpet in the opponent's SECRET PASSAGE may not contact opposing ROBOTS, regardless of who initiates the contact.
Violation: TECH FOUL

TEAMS should take note that they are putting themselves at great risk for TECH FOULS if they choose to enter their opponent's SECRET PASSAGE

G22 ROBOTS may not pin an opponent's ROBOT for more than five (5) seconds. A ROBOT will be considered pinned until the ROBOTS have separated by at least six (6) feet. The pinning ROBOT(s) must then wait for at least three (3) seconds before attempting to pin the same ROBOT again. Pinning is transitory through other objects. If the pinned ROBOT chases the pinning ROBOT upon retreat, the pinning ROBOT will not be penalized, and the pin will be considered complete.

Violation: FOUL. For every five (5) seconds in which the situation is not corrected, FOUL. If extended and egregious, RED CARD

There is no *FIRST* Robotics Competition specific definition of pin, so a general definition applies; "to prevent or stop something from moving." As a result, contact is not required for pinning to occur. For example, a ROBOT parked right behind an opponent that is on the BATTER could be considered pinning because the dividers on the BATTER and the parked ROBOT prevent the opponent from moving.

Generally, pins that exceed fifteen (15) seconds are considered extended and egregious, regardless of a pinning ROBOT's mobility, however circumstances vary and the assessment is open to REFEREE discretion.

G23 Fallen (i.e. tipped over) ROBOTS attempting to right themselves (either by themselves or with assistance from a partner ROBOT) have one ten (10) second grace period in which they may not be contacted by an opponent ROBOT. This protection lasts for either ten (10) seconds or until the protected ROBOT has completed the righting operation, whichever comes first.

Violation: FOUL. If intentional, YELLOW CARD

G24 Strategies aimed at the destruction or inhibition of ROBOTS via attachment, damage, tipping, entanglements, or deliberately putting a BOULDER on an opponent's ROBOT are not allowed.

Violation: FOUL and YELLOW CARD. If harm or incapacitation occurs as a result of the strategy, RED CARD

Initiating deliberate or damaging contact with an opponent ROBOT on or inside the vertical extension of its FRAME PERIMETER is not allowed.

3.4.7 ROBOT Gameplay

- G25** A ROBOT may not attempt to stop or impede the flow of the MATCH in any of the following ways:
- A. intentionally tipping over
 - B. coordinating a blockade of the FIELD with ALLIANCE members
 - C. blocking GOAL(S) while in contact with its own BATTER using anything outside its FRAME PERIMETER except its BUMPERS
 - D. blocking more than one of the opponent's HUMAN PLAYER STATION openings while not contacting the carpet in the opponent's SECRET PASSAGE
 - E. isolating BOULDERS in the opponent's SECRET PASSAGE from opponents while not contacting the carpet in the opponent's SECRET PASSAGE

Violation: YELLOW CARD for the ALLIANCE

An example of a blockade would be two (2) or more ROBOTS on the same ALLIANCE working together to “box” an opponent ROBOT into a corner of the FIELD using the GUARDRAIL and the CASTLE WALL.

A single ROBOT blocking access to a particular DEFENSE is not considered impeding the flow of the MATCH.

- G26** At any given time, only one (1) ROBOT may contact the carpet or BATTER inside their COURTYARD.

Violation: FOUL. For every five (5) seconds in which the situation is not corrected, TECH FOUL

- G27** A ROBOT may not transfer BOULDERS from the NEUTRAL ZONE to the opponent's SECRET PASSAGE.

Violation: TECH FOUL per BOULDER

- G28** During the final twenty (20) seconds of TELEOP, ROBOTS in their COURTYARD may not contact an opponent ROBOT, regardless of who initiates the contact.

Violation: The contacted ROBOT is considered to have SCALED an open side of the TOWER at the end of the MATCH.

Teams are encouraged to consider rule [G11](#) when developing their strategies, such as attempting to draw violations of this rule.

The ARENA will play a warning sound when thirty (30) seconds remain in TELEOP as a reminder that violations for this rule will soon be enforced. When twenty (20) seconds remain in TELEOP, an additional sound will be played.

3.4.8 Human Actions

- G29** During a MATCH, DRIVE TEAMS may not use electronic devices which have the capability of receiving communications from persons outside of the CASTLE (e.g. cell phones or wearable technology).

Violation: YELLOW CARD

- G30** Only DRIVE TEAMS for the current MATCH are allowed in their respective CASTLES.

Violation: MATCH will not start until the situation is corrected. Those not displaying identification must leave the ARENA.

- G31** DRIVE TEAMS must wear proper identification while in the ARENA. Proper identification consists of:
- A. All DRIVE TEAM members wearing their designated buttons above the waist in a clearly visible location at all times while in the ARENA.
 - B. The COACH wearing the identification button bearing the contrasting colored dot.
 - C. During a Playoff MATCH, the ALLIANCE CAPTAIN clearly displaying the designated ALLIANCE CAPTAIN identifier (e.g. hat or armband).

Violation: MATCH will not start until the situation is corrected. Those not displaying identification must leave the ARENA.

- G32** Teams may not interfere with any automated scoring hardware.

Violation: RED CARD for the ALLIANCE

Examples of violations of this rule include, but are not limited to, tampering with the sensors, blocking BOULDERS from exiting the TOWER, or attempting to feed BOULDERS backwards through a TOWER.

- G33** BOULDERS may only be introduced to the FIELD

- A. during TELEOP,
- B. by a DRIVER or HUMAN PLAYER, and
- C. through one of the holes in the HUMAN PLAYER STATION.

Violation: FOUL per BOULDER

- G34** No more than six (6) BOULDERS may remain in a CASTLE during TELEOP. If the BOULDER count ever exceeds six (6), excess BOULDERS must be introduced to the FIELD immediately.

Violation: FOUL per excess BOULDER

The intent is that as soon as a 7th BOULDER arrives in the CASTLE, the ALLIANCE begins a concerted, good will effort to enter any extra BOULDERS back on to the FIELD as quickly and as safely as possible. It is not our intent to issue penalties if the DRIVE TEAM member clearing any surplus BOULDERS gets hung up by having to work their way around other people in the CASTLE. However if they are perceived as deliberately lagging in the eyes of a REFEREE, they will be issued a penalty.

- G35** A ROBOT shall be operated solely by the DRIVERS and/or HUMAN PLAYERS of that Team, and/or an ALLIANCE partner within the SPY BOX.

Violation: Offending ROBOT will be DISABLED

Exceptions may be made before a MATCH for major conflicts, e.g. religious holidays, major testing, transportation issues, etc.

- G36** COACHES may not touch BOULDERS unless for safety purposes.

Violation: FOUL

- G37** DRIVE TEAM members may not contact anything outside the zone in which they started the MATCH (either the CASTLE or SPY BOX) for the duration of the MATCH, unless for personal safety.

Violation: FOUL. If strategic, RED CARD.

3.4.9 BOULDER Rules

G38 ROBOTS may not control more than one (1) BOULDER at any time.

Violation: FOUL per extra BOULDER

Moving or positioning a BOULDER to gain advantage is considered “control.”

Examples include, but are not limited to:

- A. “carrying” (holding BOULDERS inside a ROBOT)
- B. “herding” (intentionally pushing or impelling BOULDERS to a desired location or direction)
- C. “trapping” (holding one or more BOULDERS against a FIELD element in an attempt to shield or guard them)
- D. “launching” (shooting BOULDERS into the air, kicking across the floor, or throwing in a forceful way)

Examples of interaction with BOULDERS that are not “control” include, but are not limited to:

- A. “bulldozing” (inadvertent contact with BOULDERS while in the path of the ROBOT moving about the FIELD)
- B. “deflecting” (being hit by a BOULDER that bounces into or off of a ROBOT).

If a BOULDER becomes lodged in or on a ROBOT, it will be considered controlled by the ROBOT. It is important to design your ROBOT so that it is impossible to inadvertently or unintentionally control more than the allowed maximum.

G39 ROBOTS are prohibited from launching BOULDERS unless they are in contact with the opponent’s TOWER or carpet in the opponent’s COURTYARD, and not in contact with any other carpet.

Violation: TECH FOUL per BOULDER

Actions such as “carrying”, “herding”, and “trapping” are not violations of this rule.

- G40** A ROBOT may not cause a BOULDER to move from the NEUTRAL ZONE into the opponent's COURTYARD unless:
- A. the ROBOT contacts the BOULDER within OUTER WORKS, and
 - B. the ROBOT completes its CROSSING (e.g. doesn't completely back out of the OUTER WORKS into the NEUTRAL ZONE)

Violation: TECH FOUL per BOULDER

Examples meeting the requirements of this rule include, but are not limited to:

- A. A ROBOT picks up a BOULDER in the NEUTRAL ZONE, and CROSSES a DEFENSE carrying the BOULDER
- B. A ROBOT, starting in the NEUTRAL ZONE, bumps a BOULDER through a DEFENSE, contacting the BOULDER within the OUTER WORKS at least once. The ROBOT then completes the CROSSING itself.

Examples NOT meeting this rule include, but are not limited to:

- A. A ROBOT fully in the NEUTRAL ZONE lobs a boulder over a DEFENSE, then CROSSES a DEFENSE (this violates the rule because the ROBOT did not contact the BOULDER within OUTER WORKS)
- B. A ROBOT fully in the NEUTRAL ZONE rolls a BOULDER over a DEFENSE, then CROSSES a DEFENSE (this violates the rule because the ROBOT did not contact the BOULDER within OUTER WORKS)
- C. A ROBOT attempts to CROSS a DEFENSE with a BOULDER, drops the BOULDER so it rolls into the opponent's COURTYARD, backs fully out of the OUTER WORKS to get a running start, then CROSSES a DEFENSE (this violates the rule because the ROBOT completely backed out of OUTER WORKS into the NEUTRAL ZONE)

- G40-1A** ROBOT may not hold a Low Bar flap open for the purpose of allowing a DRIVE TEAM member to transfer BOULDERS into their opponent's COURTYARD.

Violation: TECH FOUL per BOULDER

G41 During each CROSSING, a ROBOT may not cause more than one (1) BOULDER to move from the NEUTRAL ZONE into the opponent's COURTYARD.

Violation: TECH FOUL per additional BOULDER

For example, if a Red ROBOT is CROSSING the Blue OUTER WORKS and a Blue ROBOT causes a BOULDER to bounce off of the Red ROBOT and through the OUTER WORKS, there is no violation of this rule as the action was caused by the Blue ROBOT.

A ROBOT will be in violation of G41 if it, while CROSSING the OUTERWORKS with a BOULDER in its CONTROL, causes a different BOULDER (e.g. a BOULDER paused in the OUTERWORKS) to complete a transition from the NEUTRAL ZONE to the COURTYARD, regardless of how the BOULDER got from the NEUTRAL ZONE to the OUTERWORKS.

G42 ROBOTS may not intentionally eject BOULDERS from the FIELD other than through the GOALS.

Violation: FOUL per BOULDER ejected

3.4.10 DEFENSE Rules

G43 ROBOTS on the same half of the FIELD as their ALLIANCE TOWER may not interfere with opponent ROBOTS attempting to traverse OUTER WORKS (regardless of direction). A ROBOT is considered traversing the opponent's OUTER WORKS if any part of its BUMPERS are within the opponent's OUTER WORKS and no part of it is in their opponent's SECRET PASSAGE.

Violation: FOUL. For every five (5) seconds in which the situation is not corrected, FOUL

Interference includes, but is not limited to, pushing, bumping, or restricting a ROBOT trying to traverse their opponent's OUTER WORKS or obstructing the operation of a DEFENSE (such as holding the Sally Port doors closed).

This rule protects a ROBOT so long as their BUMPERS are within the OUTER WORKS whether a traversal attempt is successful or not.

G44 A ROBOT may not use the SHIELD(S) to circumvent a DEFENSE.

Violation: FOUL and YELLOW CARD

The DEFENSE SHIELDS are not intended to be weight bearing and are not to be used as a strategy for avoiding the challenge of the DEFENSE.

For example, a ROBOT that "bounces" off of a DEFENSE SHIELD while traversing the DEFENSE is not in violation of this rule as their strategy was not to use the SHIELDS to avoid the DEFENSE. In contrast, a ROBOT "leapfrogging" or "spider climbing" across a DEFENSE by applying force to the SHIELDS and lifting itself over the DEFENSE is a violation of this rule.

G45 A ROBOT may not pass completely over the Low Bar.

Violation: FOUL and YELLOW CARD

4

Robot

4.1 Overview.....	2
4.2 General ROBOT Design	5
4.3 Safety & Damage Prevention	7
4.4 Budget Constraints.....	8
4.5 Fabrication Schedule	11
4.6 Material Utilization	13
4.7 BUMPER Rules	14
4.8 Motors & Actuators.....	20
4.9 Power Distribution	21
4.10 Control, Command & Signals System.....	29
4.11 Pneumatic System.....	33
4.12 OPERATOR CONSOLE	37

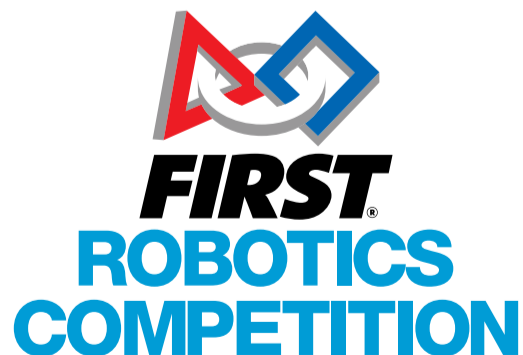

FIRST[®], the *FIRST*[®] logo, *FIRST*[®] Robotics Competition, *Coopertition*[®], *Gracious Professionalism*[®], and *Sport for the Mind*[™] are trademarks of the United States Foundation for Inspiration and Recognition of Science and Technology (*FIRST*[®]). © 2015-2016 *FIRST*. All rights reserved.

Official *FIRST*[®] Robotics Competition teams and Partners are permitted to make reproductions of this manual for team and Partner use only. Any use, reproduction, or duplication of this manual for purposes other than directly by the team or Partner as part of *FIRST*[®] Robotics Competition participation is strictly prohibited without specific written permission from *FIRST*.

4 ROBOT

This section of the 2016 *FIRST* Robotics Competition Game Manual presents legislation relevant to the construction of a 2016 *FIRST* Robotics Competition ROBOT. ROBOTS will be Inspected at each *FIRST* Robotics Competition event to confirm compliance before being allowed to compete, per [Section 5 \(5.5.2 Eligibility and Inspection\)](#).

4.1 Overview

The rules listed below explicitly address what and how parts and materials may be used on a 2016 *FIRST* Robotics Competition ROBOT. There are many reasons for the structure of the rules, including safety, reliability, parity, creation of a reasonable design challenge, adherence to professional standards, impact on the competition, compatibility with the Kit of Parts (KOP), which is the collection of items listed on any Kickoff Kit Checklists, distributed via *FIRST* Choice, or obtained via a Product Donation Voucher (PDV), etc.

Another intent of these rules is to have all energy sources and active actuation systems on the ROBOT (e.g. batteries, compressors, motors, servos, cylinders, and their controllers) drawn from a well-defined set of options. This is to ensure that all Teams have access to the same actuation resources and that the Inspectors are able to accurately assess the legality of a given part.

FIRST Robotics Competition ROBOTS are made up of COMPONENTS and MECHANISMS. A COMPONENT is any part in its most basic configuration, which cannot be disassembled without damaging or destroying the part or altering its fundamental function. A MECHANISM is a COTS or custom assembly of COMPONENTS that provide specific functionality on the ROBOT. A MECHANISM can be disassembled (and then reassembled) into individual COMPONENTS without damage to the parts.

Many rules in this section reference Commercial-Off-The-Shelf (COTS) items. A COTS item must be a standard (i.e. not custom order) part commonly available from a VENDOR for all Teams for purchase. To be a COTS item, the COMPONENT or MECHANISM must be in an unaltered, unmodified state. Items that are no longer commercially available but are functionally equivalent to the original condition as delivered from the VENDOR are considered COTS and may be used.

Example 1: A Team orders two (2) ROBOT grippers from RoboHands Corp. and receives both items. They put one in their storeroom and plan to use it later. Into the other, they drill “lightening holes” to reduce weight. The first gripper is still classified as a COTS item, but the second gripper is now a FABRICATED ITEM, as it has been modified.

Example 2: A Team obtains openly available blueprints of a drive module commonly available from Wheels-R-Us Inc. and has local machine shop “We-Make-It, Inc.” manufacture a copy of the part for them. The produced part is NOT a COTS item, because it is not commonly carried as part of the standard stock of We-Make-It, Inc.

Example 3: A Team obtains openly available design drawings from a professional publication during the pre-season, and uses them to fabricate a gearbox for their ROBOT during the build period following Kickoff. The design drawings are considered a COTS item, and may be used as “raw material” to fabricate the gearbox. The finished gearbox itself would be a FABRICATED ITEM, and not a COTS item.

Example 4: A COTS part that has non-functional label markings added would still be considered a COTS part, but a COTS part that has device-specific mounting holes added is a FABRICATED ITEM.

Example 5: A team has a COTS single-board processor version 1.0, which can no longer be purchased. Only the COTS single-board processor version 2.0 may be purchased. If the COTS single-board processor version 1.0 is functionally equivalent to its original condition, it may be used.

Example 6: A team has a COTS gearbox which has been discontinued. If the COTS gearbox is functionally equivalent to its original condition, it may be used.

A **VENDOR** is a legitimate business source for COTS items that satisfies all of the following criteria:

- A. has a Federal Tax Identification number. In cases where the **VENDOR** is outside of the United States, they must possess an equivalent form of registration or license with the government of their home nation that establishes and validates their status as a legitimate business licensed to operate within that country.
- B. is not a “wholly owned subsidiary” of an *FIRST* Robotics Competition Team or collection of *FIRST* Robotics Competition Teams. While there may be some individuals affiliated with both an *FIRST* Robotics Competition Team and the **VENDOR**, the business and activities of the Team and **VENDOR** must be completely separable.
- C. must be able to ship any general (i.e., non-*FIRST* unique) product within five business days of receiving a valid purchase request. It is recognized that certain unusual circumstances (such as 1,000 *FIRST* Teams all ordering the same part at once from the same **VENDOR**) may cause atypical delays in shipping due to backorders for even the largest **VENDOR**s. Such delays due to higher-than-normal order rates are excused.

- D. should maintain sufficient stock or production capability to fill Teams' orders within a reasonable period during the season (less than 1 week). (Note that this criterion may not apply to custom-built items from a source that is both a VENDOR and a fabricator. For example, a VENDOR may sell flexible belting that the Team wishes to procure to use as treads on their drive system. The VENDOR cuts the belting to a custom length from standard shelf stock that is typically available, welds it into a loop to make a tread, and ships it to a Team. The fabrication of the tread takes the VENDOR two weeks. This would be considered a FABRICATED ITEM, and the two weeks ship time is acceptable.) Alternately, the Team may decide to fabricate the treads themselves. To satisfy this criterion, the VENDOR would just have to ship a length of belting from shelf stock (i.e. a COTS item) to the Team within five business days and leave the welding of the cuts to the Team.)
- E. makes their products available to all *FIRST* Robotics Competition Teams. VENDOR must not limit supply or make a product available to just a limited number of *FIRST* Robotics Competition Teams.

The intent of this definition is to be as inclusive as possible to permit access to all legitimate sources, while preventing ad hoc organizations from providing special-purpose products to a limited subset of Teams in an attempt to circumvent the cost accounting rules.

FIRST desires to permit Teams to have the broadest choice of legitimate sources possible, and to obtain COTS items from the sources that provide them with the best prices and level of service available. Teams also need to protect against long delays in availability of parts that will impact their ability to complete their ROBOT. The *FIRST* Robotics Competition build season is brief, so the VENDOR must be able to get their product, particularly *FIRST* unique items, to a Team in a timely manner.

Ideally, chosen VENDORS should have national distributors (e.g. Home Depot, Lowes, MSC, Radio Shack, McMaster-Carr, etc.). Remember, *FIRST* Robotics Competition events are not always near home – when parts fail, local access to replacement materials is often critical.

A FABRICATED ITEM is any COMPONENT or MECHANISM that has been altered, built, cast, constructed, concocted, created, cut, heat treated, machined, manufactured, modified, painted, produced, surface coated, or conjured partially or completely into the final form in which it will be used on the ROBOT.

Note that it is possible for an item (typically raw materials) to be neither COTS nor a FABRICATED ITEM. For example, a 20 ft. length of aluminum which has been cut into 5ft. pieces for transport is neither COTS (it's not in the state received from the VENDOR), nor a FABRICATED ITEM (the cuts were not made to advance the part towards its final form on the ROBOT).

Teams may be asked to provide documentation proving legality of non-2016 KOP items during Inspection where a Rule specifies limits for a legal part (e.g. pneumatic items, current limits, COTS electronics, etc.).

Some of these rules make use of English unit requirements for parts. If your team has a question about a metric-equivalent part's legality, please e-mail your question to frcparts@firstinspires.org for an official ruling. To seek approval for alternate devices for inclusion in future *FIRST* Robotics Competition seasons, please contact frcparts@firstinspires.org with item specifications.

Teams should acknowledge the support provided by the corporate Sponsors and Mentors with an appropriate display of their school and Sponsors names and/or logos (or the name of the supporting youth organization, if appropriate).

FIRST Robotics Competition can be a full-contact ROBOT competition and may include rigorous game play. While Game and ROBOT Rules limit severe damage to ROBOTS, Teams should design their ROBOTS to be robust.

4.2 General ROBOT Design

- R1** A Team must submit their ROBOT for Inspection. The ROBOT must be an electromechanical assembly built by the *FIRST* Robotics Competition Team to perform specific tasks when competing in *FIRST* STRONGHOLD. The ROBOT must include all of the basic systems required to be an active participant in the game – power, communications, control, BUMPERS, and movement. The ROBOT implementation must obviously follow a design approach intended to play *FIRST* STRONGHOLD (e.g. a box of unassembled parts placed on the FIELD, or a ROBOT designed to play a different game does not satisfy this definition).

R1 requires that the ROBOT a Team uses in competition was built by that Team, but isn't intended to prohibit assistance from other Teams (e.g. fabricating elements, supporting construction, writing software, developing game strategy, contributing COMPONENTS and/or MECHANISMS, etc.).

- R2** The ROBOT (excluding BUMPERS) must have a FRAME PERIMETER, contained within the BUMPER ZONE, that is comprised of fixed, non-articulated structural elements of the ROBOT. Minor protrusions no greater than ¼ in. such as bolt heads, fastener ends, and rivets are not considered part of the FRAME PERIMETER.

To determine the FRAME PERIMETER, wrap a piece of string around the ROBOT (excluding BUMPERS) at the BUMPER ZONE described in [R22](#). The string describes this polygon.

Note: to permit a simplified definition of the FRAME PERIMETER and encourage a tight, robust connection between the BUMPERS and the FRAME PERIMETER, minor protrusions such as bolt heads, fastener ends, rivets, etc. are excluded from the determination of the FRAME PERIMETER.

- R3** The ROBOT must satisfy the following size constraints:
- total length of the FRAME PERIMETER sides must not exceed 120 in. (see [Figure 4-1](#) for examples),
 - must not extend greater than 15 in. beyond the FRAME PERIMETER (see [Figure 4-2](#) for examples) (see G18), and
 - ROBOT STARTING CONFIGURATION height must not exceed 54 in. (note that ROBOT height may exceed this limit in-MATCH as allowed by G17).

Figure 4-1: FRAME PERIMETER Extension

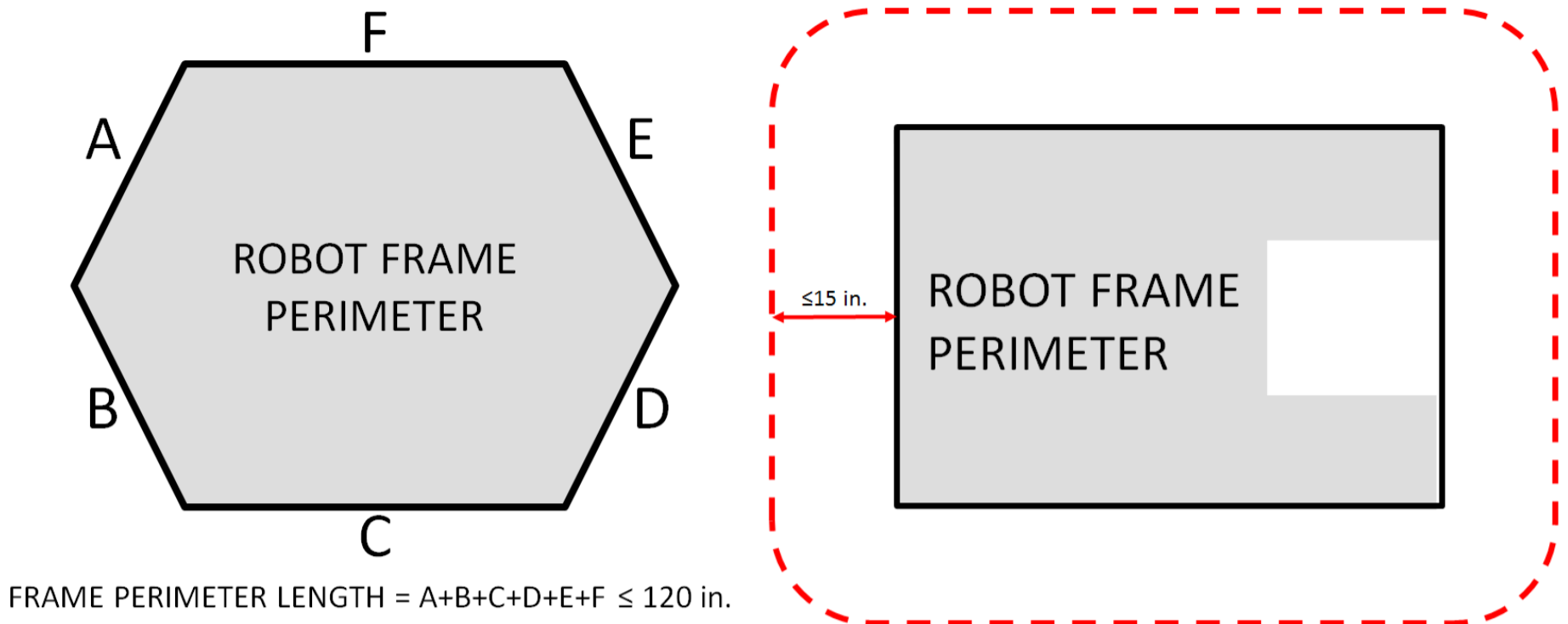
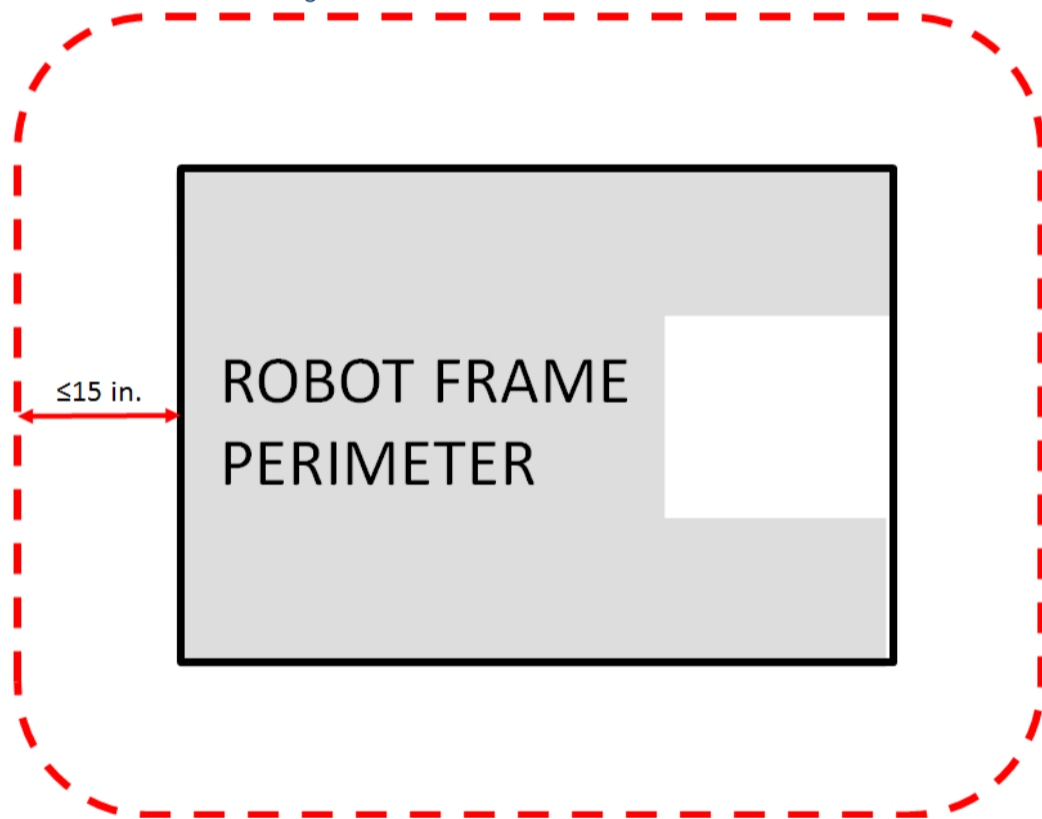

Figure 4-2: FRAME PERIMETER Extension



Expect to have to demonstrate a ROBOT'S ability to constrain itself per B above during Inspection. PLAYING CONFIGURATION constraints may be implemented with either hardware or software.

Teams should think carefully about how they will transfer their ROBOTS from place to place during the events. Many *FIRST* Robotics Competitions take place in venues with standard sized doors. Be sure to consider the size of the ROBOT on its cart to make sure it will fit through doors. Also consider the size of the ROBOT to ensure that it will fit into a shipping crate, bag, vehicle, etc.

- R4** In the STARTING CONFIGURATION (the physical configuration in which a ROBOT starts a MATCH), no part of the ROBOT shall extend outside the vertical projection of the FRAME PERIMETER, with the exception of its BUMPERS and minor protrusions such as bolt heads, fastener ends, rivets, etc.

If a ROBOT is designed as intended and each side is pushed up against a vertical wall (in STARTING CONFIGURATION and with BUMPERS removed), only the FRAME PERIMETER (or minor protrusions) will be in contact with the wall.

- R5** The ROBOT weight must not exceed 120 lbs. When determining weight, the basic ROBOT structure and all elements of all additional MECHANISMS that might be used in different configurations of the ROBOT shall be weighed together.

For the purposes of determining compliance with the weight limitations, the ROBOT BUMPERS and ROBOT battery and its associated half of the Anderson cable quick connect/disconnect pair (including no more than 12 in. of cable per leg, the associated cable lugs, connecting bolts, and insulation) are excluded.

- R6** Traction devices must not have surface features such as metal, sandpaper, hard plastic studs, cleats, hook-loop fasteners or similar attachments that could damage the ARENA. Traction devices include all parts of the ROBOT that are designed to transmit any propulsive and/or braking forces between the ROBOT and FIELD carpet.

- R7** ROBOTS must allow removal of BOULDERS from the ROBOT and the ROBOT from FIELD elements while DISABLED and powered off.

ROBOTS will not be re-enabled after the MATCH, so Teams must be sure that BOULDERS and ROBOTS can be quickly, simply, and safely removed. Before they arrive at events, Teams should practice removal of BOULDERS from their ROBOTS, and removal of their ROBOTS from FIELD elements such as the TOWER, with the ROBOTS in a powered-off state.

4.3 Safety & Damage Prevention

- R8** Protrusions from the ROBOT and exposed surfaces on the ROBOT shall not pose hazards to the ARENA elements (including the BOULDERS) or people.

If the ROBOT includes protrusions that form the "leading edge" of the ROBOT as it drives and have a surface area of less than 1 in.², it will invite detailed Inspection. For example, forklifts, lifting arms, or grapples may be carefully Inspected for these hazards.

- R9** ROBOT parts shall not be made from hazardous materials, be unsafe, cause an unsafe condition, or interfere with the operation of other ROBOTS.

Examples of items that will violate [R9](#) include (but are not limited to):

- A. Shields, curtains, or any other devices or materials designed or used to obstruct or limit the vision of any DRIVERS and/or COACHES and/or interfere with their ability to safely control their ROBOT
- B. Speakers, sirens, air horns, or other audio devices that generate sound at a level sufficient to be a distraction
- C. Any devices or decorations specifically intended to jam or interfere with the remote sensing capabilities of another ROBOT, including vision systems, acoustic range finders, sonars, infrared proximity detectors, etc. (e.g. including imagery on your ROBOT that, to a reasonably astute observer, mimics the retro-reflective features of the TOWER described in Section 2.3.1.3 TOWER)
- D. Exposed lasers other than Class I.
- E. Flammable gasses
- F. Any device intended to produce flames or pyrotechnics
- G. Hydraulic fluids or hydraulic items
- H. Switches or contacts containing liquid mercury
- I. Circuitry used to create voltages in excess of 24V
- J. Any ballast not secured sufficiently, including loose ballast e.g. sand, ball bearings, etc., such that it may become loose during a MATCH.
- K. Exposed, untreated hazardous materials (e.g. lead weights) used on the ROBOT. These materials may be permitted if painted, encapsulated or otherwise sealed to prevent contact. These materials may not be machined in any way at an event.
- L. tire sealant

Teams should provide MSD Sheets for any materials they use that might be considered questionable during ROBOT Inspection.

4.4 Budget Constraints

- R10** The total cost of all items on the ROBOT shall not exceed \$4000 USD. All costs are to be determined as explained in [Section 4.4 Budget Constraints](#). Exceptions are as follows:
- A. individual COTS items that are less than \$5 USD each and
 - B. KOP items

Teams should be prepared to disclose to Inspectors the cost of any non-KOP item and the total cost of the ROBOT.

If the item is a KOP item, it does not need to be on the Cost Accounting Worksheet (CAW).

Per T11, Teams must be prepared to display a CAW to Inspectors during Inspection. The CAW may be displayed in either printed or electronic form.

Individual COMPONENTS or MECHANISMS, not excluded in [R10](#), that are retrieved from previous ROBOTS and used on 2016 ROBOTS must have their undepreciated cost included in the 2016 CAW and applied to the overall cost assessment.

R11 No individual, non-KOP item shall have a value that exceeds \$400 USD. The total cost of COMPONENTS purchased in bulk may exceed \$400 USD as long as the cost of an individual COMPONENT does not exceed \$400 USD.

If a COTS item is part of a modular system that can be assembled in several possible configurations, then each individual module must fit within the price constraints defined in [R11](#).

If the modules are designed to assemble into a single configuration, and the assembly is functional in only that configuration, then the total cost of the complete assembly including all modules must fit within the price constraints defined in [R11](#).

In summary, if a VENDOR sells a system or a kit, a team must use the entire system/kit Fair Market Value and not the value of its COMPONENT pieces.

Example 1: VENDOR A sells a gearbox that can be used with a number of different gear sets, and can mate with two different motors they sell. A team purchases the gearbox, a gear set, and a motor (which are not offered together as an assembly or kit), then assembles them together. Each part is treated separately for the purpose of CAW costing, since the purchased pieces can each be used in various configurations.

Example 2: VENDOR B sells a robotic arm assembly that the team wants to use. However, it costs \$700 USD, so they cannot use it. The VENDOR sells the “hand”, “wrist”, and “arm” as separate assemblies, for \$200 USD each. A team wishes to purchase the three items separately, then reassemble them. This would not be legal, as they are really buying and using the entire assembly, which has a Fair Market Value of \$700 USD.

Example 3: VENDOR C sells a set of wheels or wheel modules that are often used in groups of four. The wheels or modules can be used in other quantities or configurations. A team purchases four and uses them in the most common configuration. Each part is treated separately for the purpose of CAW costing, since the purchased pieces can be used in various configurations.

R12 The CAW cost of each non-KOP item must be calculated based on the unit fair market value for the material and/or labor, except for labor provided by Team members (including sponsor employees who are members of the team), members of other Teams, event provided Machine Shops and shipping.

Example 1: A Team orders a custom bracket made by a company to the Team's specification. The company's material cost and normally charged labor rate apply.

Example 2: A Team receives a donated sensor. The company would normally sell this item for \$52 USD, which is therefore its fair market value.

Example 3: Special price discounts from National Instruments and other *FIRST* Robotics Competition Suppliers are being offered to all *FIRST* Teams. The discounted purchase price of items from these sources may be used in the additional parts accounting calculations.

Example 4: A Team purchases steel bar stock for \$10 USD and has it machined by a local machine shop. The machine shop is not considered a team Sponsor, but donates two (2) hours of expended labor anyway. The Team must include the estimated normal cost of the labor as if it were paid to the machine shop, and add it to the \$10 USD.

Example 5: A Team purchases steel bar stock for \$10 USD and has it machined by a local machine shop that is a recognized Sponsor of the Team. If the machinists are considered members of the Team, their labor costs do not apply. The total applicable cost for the part would be \$10 USD.

It is in the best interests of the Teams and *FIRST* to form relationships with as many organizations as possible. Teams are encouraged to be expansive in recruiting and including organizations in their team, as that exposes more people and organizations to *FIRST*. Recognizing supporting companies as Sponsors of, and members in, the Team is encouraged, even if the involvement of the Sponsor is solely through the donation of fabrication labor.

Example 6: A Team purchases steel bar stock for \$10 USD and has it machined by another Team. The total applicable cost for the part would be \$10 USD.

Example 7: A Team purchases a 4 by 4 ft sheet of aluminum, but only uses a piece 10 by 10 in. on their ROBOT. The Team identifies a source that sells aluminum sheet in 1 by 1 ft pieces. The Team may cost their part on the basis of a 1 by 1 ft piece, even though they cut the piece from a larger bulk purchase. They do not have to account for the entire 4 by 4 ft bulk purchase item.

4.5 Fabrication Schedule

- R13** Physical ROBOT elements created before Kickoff are not permitted. Exceptions are:
- A. OPERATOR CONSOLE,
 - B. BUMPERS (a protective assembly designed to attach to the exterior of the ROBOT and constructed as specified in [Section 4.7 BUMPER Rules](#)),
 - C. battery assemblies per [R5](#),
 - D. FABRICATED ITEMS consisting of one COTS electrical device (e.g. a motor or motor controller), connectors, and any materials used to secure and insulate those connectors

Please note that this means that FABRICATED ITEMS from ROBOTS entered in previous *FIRST* competitions may not be used on ROBOTS in the 2016 *FIRST* Robotics Competition (other than those allowed per [R13-B](#), [R13-C](#), and [R13-D](#)). Before the formal start of the *FIRST* Robotics Competition Build Season, Teams are encouraged to think as much as they please about their ROBOTS. They may develop prototypes, create proof-of-concept models, and conduct design exercises. Teams may gather all the raw stock materials and COTS COMPONENTS they want.

Example 1: A Team designs and builds a two-speed shifting transmission during the fall as a training exercise. After Kickoff, they utilize all the design principles they learned in the fall to design their ROBOT. To optimize the transmission design for their ROBOT, they improve the transmission gear ratios and reduce the size, and build two new transmissions, and place them on the ROBOT. All parts of this process are permitted activities.

Example 2: A Team re-uses a 2016-legal motor from a previous Robot which has had connectors added to the wires. This is permitted, per exception [D](#), because the motor is a COTS electrical COMPONENT.

- R14** Software and mechanical/electrical designs created before Kickoff are only permitted if the source files (complete information sufficient to produce the design) are available publicly prior to Kickoff.

Example 1: A Team realizes that the transmission designed and built in the fall perfectly fits their need for a transmission to drive the ROBOT arm. They build an exact copy of the transmission from the original design plans, and bolt it to the ROBOT. This would be prohibited, as the transmission – although made during the competition season – was built from detailed designs developed prior to Kickoff.

Example 2: A Team developed an omni-directional drive system for the 2011 competition. Over the summer of 2011 they refined and improved the control software (written in C) to add more precision and capabilities. They decided to use a similar system for the 2016 competition. They copied large sections of unmodified code over into the control software of the new ROBOT (also written in C). This would be a violation of the schedule constraint, and would not be allowed.

Example 3: The same Team decides to use LabVIEW as their software environment for 2016. Following Kickoff, they use the previously-developed C code as a reference for the algorithms and calculations required to implement their omni-directional control solution. Because they developed new LabVIEW code as they ported over their algorithms, this would be permitted.

Example 4: A different Team develops a similar solution during the fall, and plans to use the developed software on their competition ROBOT. After completing the software, they post it in a generally accessible public forum and make the code available to all Teams. Because they have made their software publicly available before Kickoff, they can use it on their ROBOT.

Example 5: A Team develops a transmission during the fall. After completing the project, they publish the CAD files on a generally accessible public forum and make them available to all Teams. Because they have made the design publicly available before Kickoff, they can use the design to create an identical transmission, fabricated after Kickoff, for use on their 2016 ROBOT.

- R15** All ROBOT elements (including items intended for use during the competition in alternative configurations of the ROBOT), with the exception of the WITHHOLDING ALLOWANCE per [R18](#), BUMPERS, and COTS items, must be bagged and sealed, by 11:59PM local time on Stop Build Day, February 23, 2016 (refer to the *Admin Manual* [Section 5 \(5.3 Instructions for “Bag and Tag”\)](#)).
- R16** Teams must stay “hands-off” their bagged ROBOT elements during the following time periods:
- between Stop Build Day and their first event,
 - during the period(s) between their events, and
 - outside of Pit hours while attending events.

Modifying parts at night offsite (e.g. pits have closed and you bring a MECHANISM back to the hotel to fix it) is a violation of [R16-C](#).

Additional time is allowed as follows:

- After Kickoff, there are no restrictions on when software may be developed.

- E. On days a team is not attending an event, they may continue development of any items permitted per [R18](#), including items listed as exempt from [R18](#), but must do so without interfacing with the ROBOT.
- F. Teams attending 2-day events may access their ROBOTS per the rules defined in the *Admin Manual* [Section 5 \(5.5 “Robot Access Period” – For Teams Attending District Events\)](#)
- G. ROBOTS may be exhibited per *Admin Manual* [Section 5 \(5.4.3 Robot Displays\)](#).

4.6 Material Utilization

- R17** Lubricants may be used only to reduce friction within the ROBOT. Lubricants must not contaminate the ARENA or other ROBOTS.
- R18** At an Event, Teams may have access to a WITHHOLDING ALLOWANCE of FABRICATED ITEMS, not bagged per [R15](#), to be used to repair and/or upgrade their ROBOT. The WITHHOLDING ALLOWANCE is a static set of items that shall not exceed 30 lbs. With permission from another Team, Teams may also have access to FABRICATED ITEMS that are part of that other Team’s WITHHOLDING ALLOWANCE to repair and/or upgrade their ROBOT. The WITHHOLDING ALLOWANCE may only be brought into the Venue when the Team initially loads in at the Event. Items made at an Event do not count towards this weight limit.

Teams should be prepared to show their WITHHOLDING ALLOWANCE items, and potentially have them weighed, during load-in.

This means teams may not store FABRICATED ITEMS outside the pits to be brought to the event at a later time. This set may be changed between events (i.e. a Team may leave a different set of items out of the bag and/or fabricate new items to bring to their next event) provided the total weight of FABRICATED ITEMS brought to the next event does not exceed thirty (30) lbs.

There is no restriction on the quantity of COTS items or items which do not meet the definitions of COTS or FABRICATED ITEMS (e.g. raw materials) that may be accessed by a Team at an Event.

For Teams attending 2-Day Events, these FABRICATED ITEMS may be used during the Robot Access Period and/or brought to the Event, but the total weight may not exceed 30 lbs. FABRICATED ITEMS constructed during the Robot Access Period and bagged with the ROBOT are exempt from this limit.

Example 1: A team creates 10 lbs of FABRICATED ITEMS after Stop Build Day. During their first Robot Access Period before their first event, they install these items on the ROBOT and bag them with the ROBOT. The team may bring up to 20 lbs. of FABRICATED ITEMS (which may be items removed from the ROBOT before bagging at the end of the Robot Access Period) with them to the event.

Example 2: A team creates 30 lbs of FABRICATED ITEMS after Stop Build Day. During their first Robot Access Period before their first event, they install these items on the ROBOT and bag them with the ROBOT. The team may not bring any FABRICATED ITEMS (including any initially bagged on Stop Build Day and removed during the Robot Access Period) with them to the event.

Items exempt from this limit are:

- A. the OPERATOR CONSOLE,
- B. any ROBOT battery assemblies (as described in [R5](#)).
- C. BUMPERS

4.7 BUMPER Rules

R19 ROBOTS are required to use BUMPERS to protect all outside corners of the FRAME PERIMETER. For adequate protection, at least 8 in. of BUMPER must be placed on each side of each outside corner (see [Figure 4-3](#)). If a side is shorter than 8 in., the entire side must be protected by BUMPER (see [Figure 4-4](#)). A round or circular FRAME PERIMETER, or segment of the FRAME PERIMETER, is considered to have an infinite number of corners.

The dimension defined in [R19](#) is measured along the FRAME PERIMETER. The portion of the BUMPER that extends into the corner is not included in the 8 in. requirement.

Figure 4-3: BUMPER Corner Examples

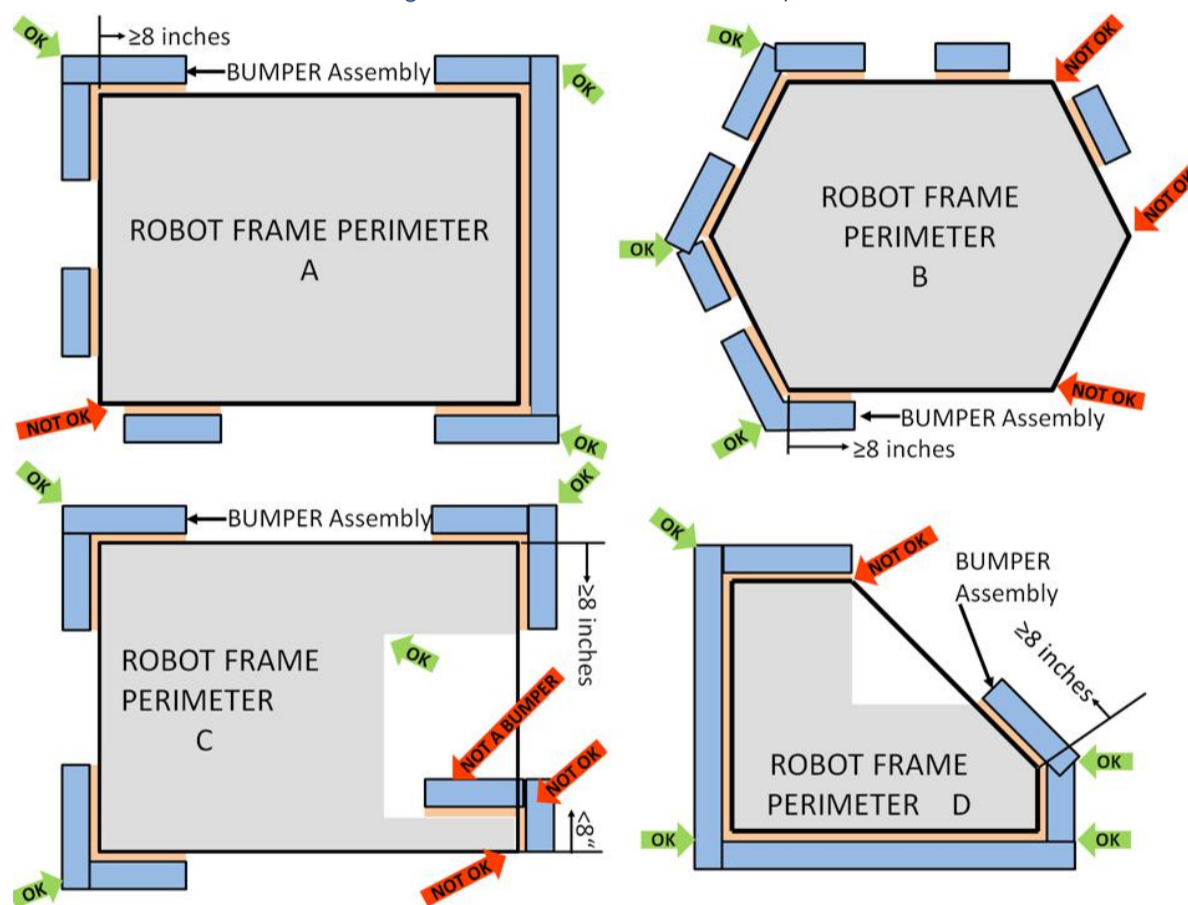
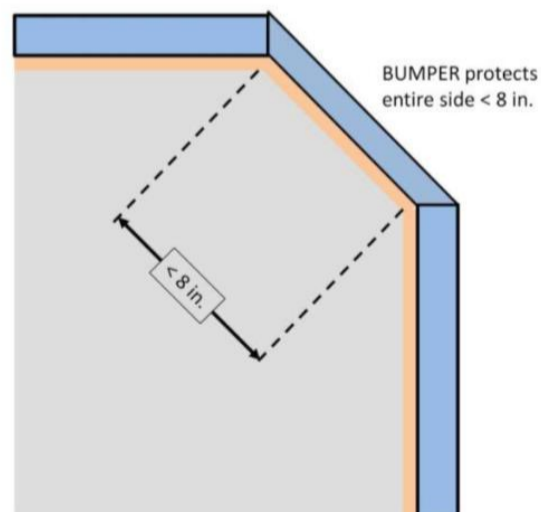

Figure 4-4: BUMPER Side Less Than 8 in.



R20 Each set of BUMPERS (including any fasteners and/or structures that attach them to the ROBOT) must weigh no more than 20 lbs.

If a multi-part attachment system is utilized (e.g. interlocking brackets on the ROBOT and the BUMPER), then the elements permanently attached to the ROBOT will be considered part of the ROBOT, and the elements attached to the BUMPERS will be considered part of the BUMPER. Each element must satisfy all applicable rules for the relevant system.

R21 BUMPERS must be constructed as follows (see [Figure 4-7](#)):

- A. be backed by $\frac{3}{4}$ in. (nominal) thick by 5 in. ($\pm \frac{1}{2}$ in) tall plywood or solid, robust wood. Small clearance pockets and/or access holes in the plywood backing are permitted, as long as they do not significantly affect the structural integrity of the BUMPER.

Particle board or chipboard is not likely to survive the rigors of *FIRST* Robotics Competition gameplay and thus not compliant with [R21-A](#).

- B. hard BUMPER parts allowed per [R21-A](#), [R21-E](#), [R21-F](#), and [R21-G](#) must not extend more than 1 in. beyond the FRAME PERIMETER with the exception of minor protrusions such as bolt heads, fastener ends, rivets, etc ([Figure 4-5](#) and [Figure 4-7](#)).

Figure 4-5: Hard Parts of BUMPER Corners

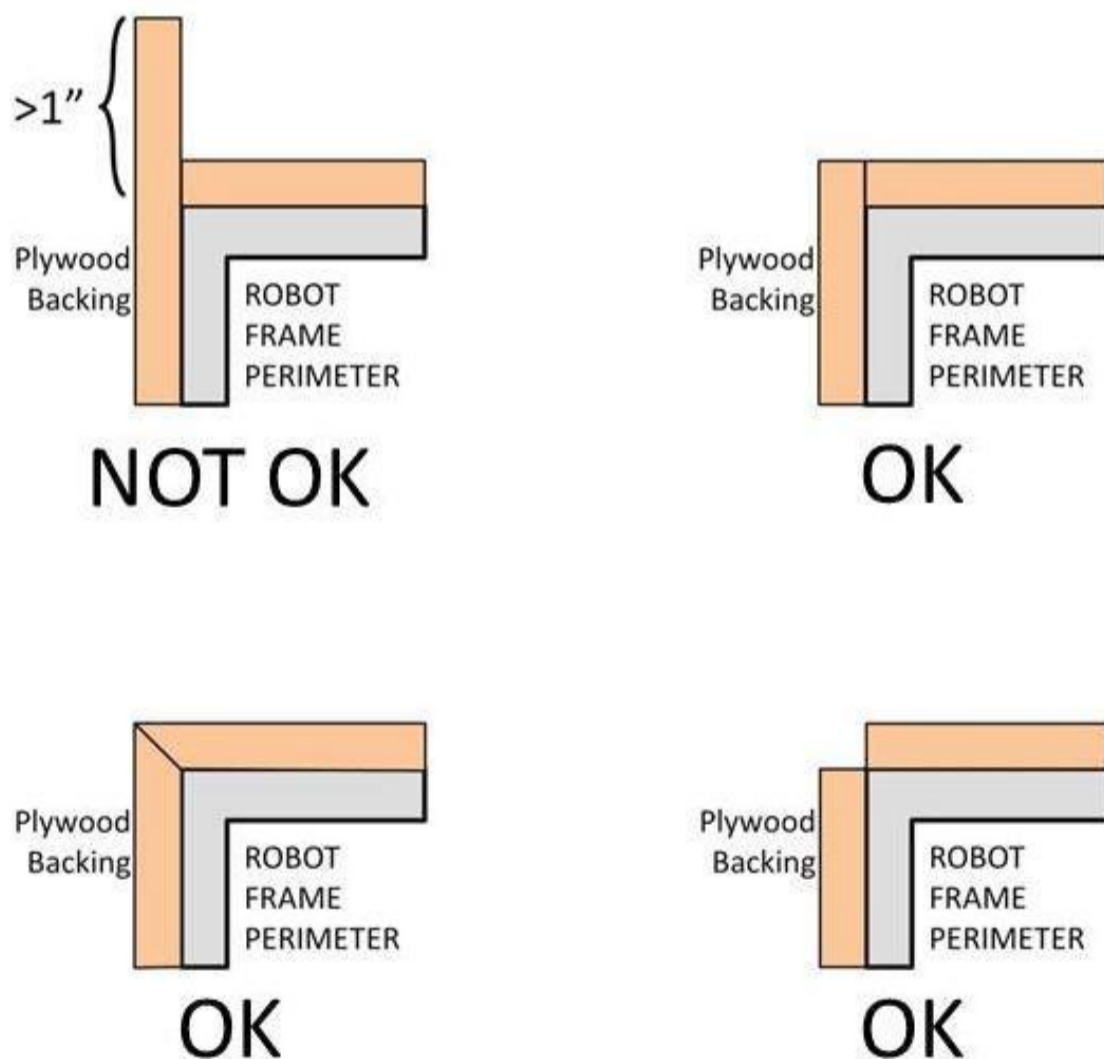

- C. use a stacked pair of approximately 2 ½ in. round, petal, or hex “pool noodles” (solid or hollow) as the BUMPER cushion material (see [Figure 4-7](#)). All pool noodles used in a BUMPER set (e.g. Red set of BUMPERS) must be the same diameter, cross-section, and density (e.g. all round hollow or all hex solid). Cushion material may extend up to 2 ½ in. beyond the end of the plywood (see [Figure 4-8](#)). To assist in applying the fabric covering, soft

fasteners may be used to attach the pool noodles to the wood backing, so long as the cross section in [Figure 4-7](#) is not significantly altered (e.g. tape compressing the pool noodles)

All pool noodles used on a ROBOT must be the same in order to maintain the desired interaction between ROBOTS in the cases of BUMPER-to-BUMPER contact. BUMPERS containing pool noodles of vastly different construction may cause a “ramp” effect when interacting with other BUMPERS.

- D. be covered with a rugged, smooth cloth. (multiple layers of cloth and seams are permitted if needed to accommodate [R27](#), provided the cross section in [Figure 4-7](#) is not significantly altered).

Silk or bedding are not considered rugged materials, however 1000D Cordura is. Tape (e.g. gaffer’s tape) matching the BUMPER color is allowed to patch small holes on a temporary basis.

The cloth must completely enclose all exterior surfaces of the wood and pool noodle material when the BUMPER is installed on the ROBOT. The fabric covering the BUMPERS must be a solid Red or Blue in color. The only markings permitted on the BUMPER fabric cover are the Team number (see [R28](#)) and hook-and-loop backed by the hard parts of the BUMPER.

Visually, the Red or Blue must be as close to the corresponding color in the *FIRST* logo as reasonable (i.e. to a reasonably astute observer, they appear similar).

- E. optionally use aluminum angle, as shown in [Figure 4-6](#) or other fasteners (e.g. staples, screws, etc.) to clamp cloth.
- F. Optionally use aluminum brackets (i.e. angle or sheet metal) to attach BUMPER segments to each other (see [Figure 4-6](#)).

Figure 4-6: Hard Parts of BUMPER Corners

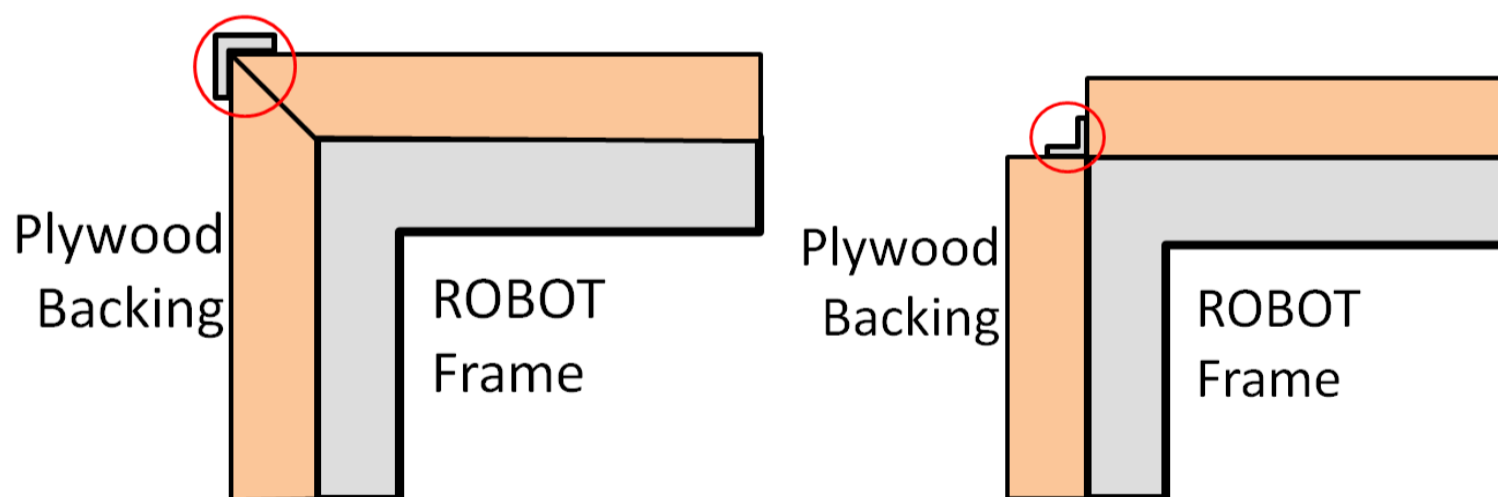

- G. must attach to the FRAME PERIMETER of the ROBOT with a rigid fastening system to form a tight, robust connection to the main structure/frame (e.g. not attached with hook-and-loop, tape, or tie-wraps). The attachment system must be designed to withstand vigorous game play. All removable fasteners (e.g. bolts, locking pins, pip-pins, etc.) will be considered part of the BUMPERS.

Figure 4-7: BUMPER Vertical Cross Section

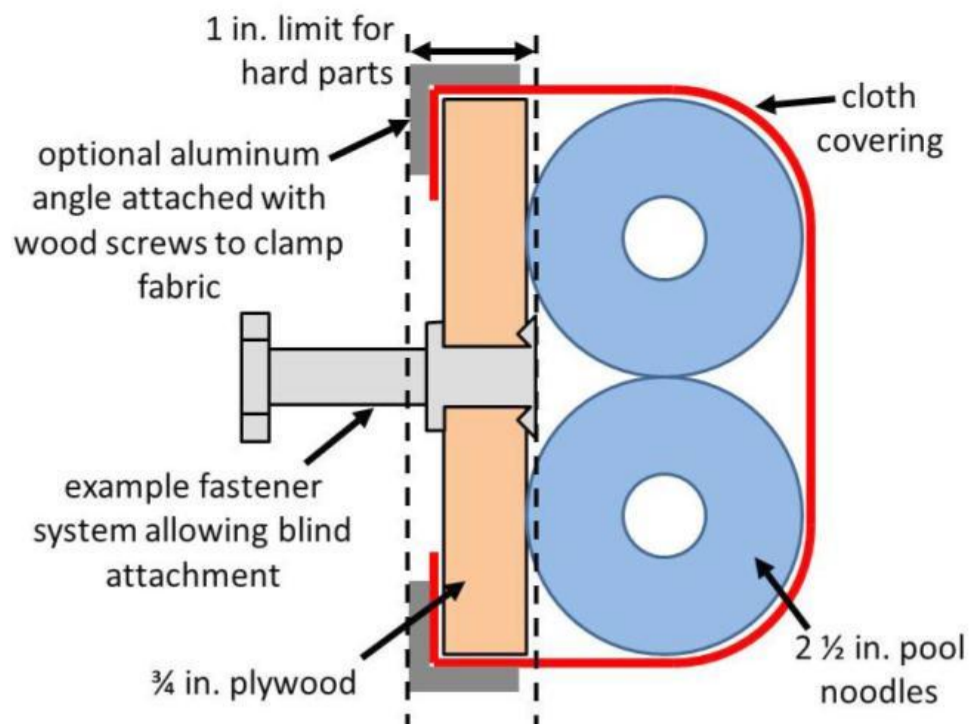

R22 BUMPERS must be located entirely within the BUMPER ZONE, which is the volume contained between two virtual horizontal planes, 4 in. above the floor and 12 in. above the floor, in reference to the ROBOT standing normally on a flat floor. BUMPERS do not have to be parallel to the floor.

This measurement is intended to be made as if the ROBOT is resting on a flat floor (without changing the ROBOT configuration), not relative to the height of the ROBOT from the FIELD carpet.

Examples include:

- A. A ROBOT that is at an angle while traversing a DEFENSE has its BUMPERS outside the BUMPER ZONE. If this ROBOT were virtually transposed onto a flat floor, and its BUMPERS are in the BUMPER ZONE, it meets the requirements of R22.
- B. A ROBOT deploys a MECHANISM which lifts the BUMPERS outside the BUMPER ZONE (when virtually transposed onto a flat floor). This violates R22.

R23 BUMPERS must not be articulated (relative to the FRAME PERIMETER).

R24 Corner joints between BUMPERS must be filled with pool noodle material. Examples of implementation are shown in [Figure 4-8](#).

Figure 4-8: Soft Parts of BUMPER Corners

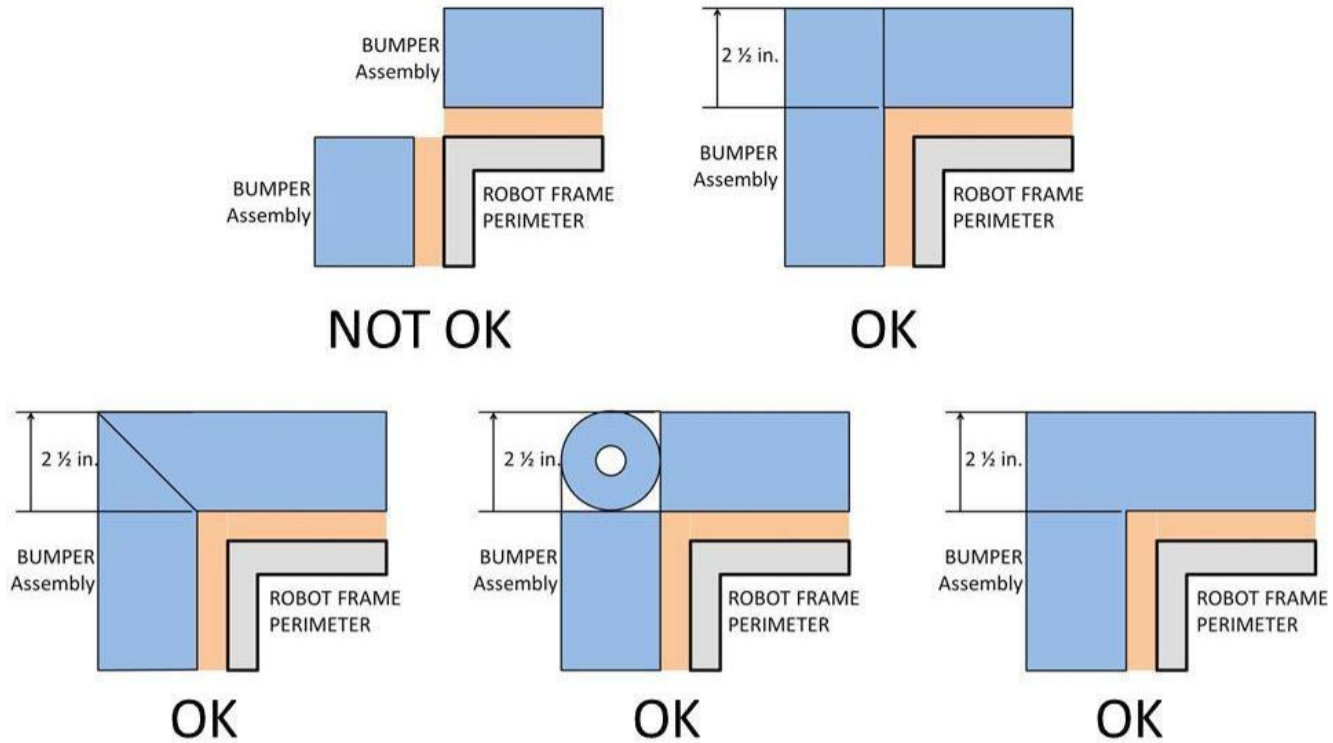

R25 BUMPERS (the entire BUMPER, not just the cover) must be designed for quick and easy installation and removal to facilitate inspection and weighing.

As a guideline, BUMPERS should be able to be installed or removed by two (2) people in fewer than five (5) minutes.

R26 BUMPERS must be supported by the structure/frame of the ROBOT (see [Figure 4-9](#)). To be considered supported, a minimum of 1/2 in. at each end of the BUMPER must be backed by the FRAME PERIMETER. Additionally, any gap between the backing material and the frame:

- A. must not be greater than 1/4" deep, or
- B. not more than 8 in. wide

Figure 4-9: BUMPER Support Examples

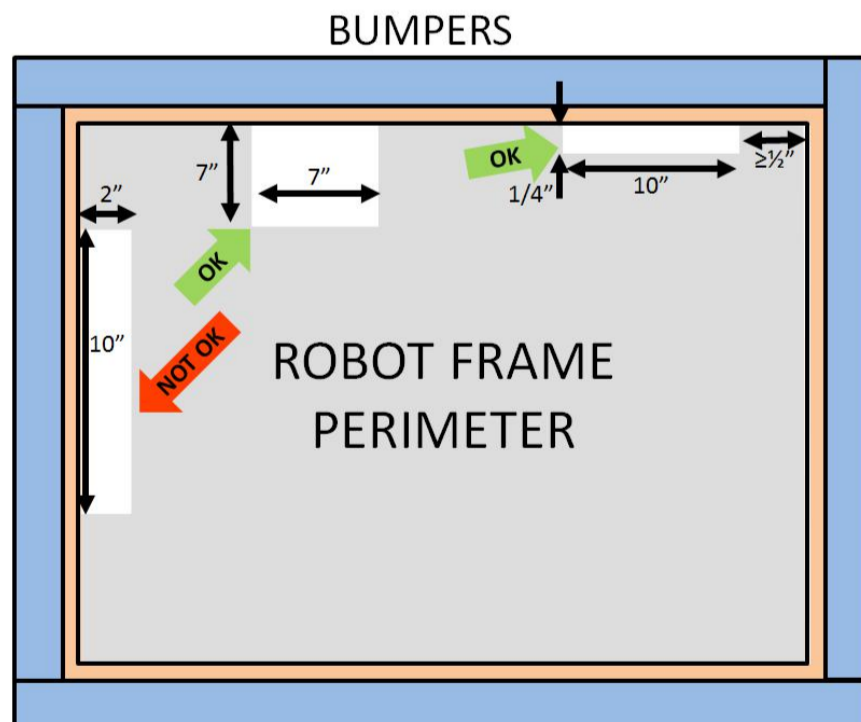

R27 Each ROBOT must be able to display Red or Blue BUMPERS to match their ALLIANCE color, as assigned in the MATCH schedule distributed at the event (reference [Section 5 \(5.1.1 MATCH Schedules\)](#)). BUMPER Markings visible when installed on the ROBOT, other than those explicitly allowed per [R21-D](#) or required per [R28](#), are prohibited.

R28 Team numbers must be displayed and positioned on the BUMPERS such that an observer walking around the perimeter of the ROBOT can unambiguously tell the Team's number from any point of view and meet the following additional criteria:

- A. consist of numerals at least 4 in. high, at least ½ in. in stroke width, and be either white in color or outlined in white
- B. must not wrap around sharp corners (less than 160 degrees) of the FRAME PERIMETER

There is no prohibition against splitting Team numbers onto different sections of BUMPER. The intent is that the Team's number is clearly visible and unambiguous so that Judges, Referees, Announcers, and other Teams can easily identify competing ROBOTS.

4.8 Motors & Actuators

R29 The only motors and actuators permitted on 2016 *FIRST* Robotics Competition ROBOTS include the following:

Table 4-1: Legal Motors

Motor Name	Part Numbers Available	Max Qty Allowed
CIM	FR801-001 M4-R0062-12 AM802-001A 217-2000 PM25R-44F-1005 PM25R-45F-1004 PM25R-45F-1003 PMR25R-45F-1003 PMR25R-44F-1005	6
BaneBots	M7-RS775-18 / RS775WC-8514 M5-RS550-12 / RS550VC-7527 / RS550	Unlimited
West Coast Products RS775 Pro	217-4347	
AndyMark 9015	am-0912	
VEX BAG	217-3351	
VEX mini-CIM	217-3371	
AndyMark PG	am-2161 (alt. PN am-2765) am-2194 (alt. PN am-2766)	
Select Automotive Motors (Window, Door, Windshield Wiper, Seat, Throttle)	Various	
Snow Blower Motor	am-2235	
Electrical solenoid actuators, no greater than 1 in. stroke and rated electrical input power no greater than 10 watts (W) continuous duty at 12 volts (VDC)		
Hard drive motors or fans that are: included in any Kickoff Kit, distributed via <i>FIRST</i> Choice, part of a legal motor controller (including manufacturer provided accessories), or part of a legal COTS computing device		
PWM COTS servos		
Factory installed vibration and autofocus motors resident in COTS computing devices (e.g. rumble motor in a smartphone).		

For servos, note that the roboRIO is limited to a max current output of 2.2A on the 6V rail (12.4W of electrical input power). Teams should make sure that their total servo power usage remains below this limit at all times.

This is the total number of each motor a Team may use on their ROBOT, not the quantity per part number. For example, each team may use up to six (6) CIM motors on their ROBOT, regardless of the quantity or combination of each individual part number used.

Given the extensive amount of motors allowed on the ROBOT, Teams are encouraged to consider the total power available from the ROBOT battery during the design and build of the ROBOT. Drawing large amounts of current from many motors at the same time could lead to drops in ROBOT battery voltage that may result in tripping the main breaker or trigger the brownout protection of the roboRIO. For more information about the roboRIO brownout protection and measuring current draw using the PDP, see [RoboRIO Brownout and Understanding Current Draw](#).

- R30** The integral mechanical and electrical system of any motor must not be modified. Motors, servos, and electric solenoids used on the ROBOT shall not be modified in any way, except as follows:
- The mounting brackets and/or output shaft/interface may be modified to facilitate the physical connection of the motor to the ROBOT and actuated part.
 - The electrical input leads may be trimmed to length as necessary and connectors or splices to additional wiring may be added.
 - The locking pins on the window motors (P/N: 262100-3030 and 262100-3040) may be removed.
 - The connector housings on window, door, windshield wiper or seat motors and Bosch motors (P/N: 6004 RA3 353-01) may be modified to facilitate lead connections.
 - Servos may be modified as specified by the manufacturer (e.g. re-programming or modification for continuous rotation).

The intent of this rule is to allow teams to modify mounting tabs and the like, not to gain a weight reduction by potentially compromising the structural integrity of any motor. The integral mechanical and electrical system of the motor is not to be modified.

Note that for the previous KOP Window motors and the Bosch motor, the gearbox is considered integral to the motor, thus the motor may not be used without the gearbox.

4.9 Power Distribution

- R31** The only legal source of electrical energy for the ROBOT during the competition, the ROBOT battery, must be a non-spillable sealed lead acid (SLA) battery with the following specifications:
- Nominal voltage: 12V
 - Nominal capacity at 20 hour discharge rate: minimum 17Ah, maximum 18.2Ah
 - Shape: Rectangular

D. Nominal Dimensions: 7.1 in x 3in. x 6.6 in (+/- .1 in. for each dimension)

E. Nominal weight: 11lbs to 14.5 lbs

F. Terminals: Nut and bolt style

Examples of batteries which meet this criteria include:

- Energys (P/N: NP18-12, NP18-12B, NP18-12BFR)
- MK Battery (P/N: ES17-12)
- Battery Mart (P/N: SLA-12V18)
- Sigma (P/N: SP12-18)
- Universal Battery (P/N: UB12180)
- Power Patrol (P/N: SLA1116)
- Werker Battery (P/N: WKA12-18NB)
- Power Sonic (P/N: PS-12180NB)
- Yuasa (P/N: NP18-12B)
- Panasonic (P/N: LC-RD-1217)
- Interstate Batteries (P/N: BSL1116)
- Duracell Ultra Battery (P/N: DURA12-18NB)

Teams should be aware that they may be asked to provide documentation of the specifications of any battery not listed above.

Batteries should be charged in accordance with manufacturer's specification. The battery charger output should not exceed 6 amps and they must have the corresponding Anderson connector installed. (Please see the [FIRST Safety Manual](#) for additional information.)

Additionally, batteries integral to and part of a COTS computing device or self-contained camera are also permitted (e.g. laptop batteries, GoPro style camera, etc.), provided they're only used to power the COTS computing device and any peripheral COTS USB input devices connected to the COTS computing device and they are securely fastened to the ROBOT.

R32 No batteries other than those allowed per R31 are allowed on the ROBOT, whether or not they are being used to supply power.

This means teams may not use additional batteries as extra weight on their ROBOTS, for example.

R33 The ROBOT battery must be secured such that it will not dislodge should the ROBOT be turned over or placed in any arbitrary orientation.

R34 Each electrical terminal on the ROBOT battery, main breaker, and their connections (lugs, stripped wire ends, etc.) to the wire must be fully insulated at all times.

R35 Non-electrical sources of energy used by the ROBOT, (i.e., stored at the start of a MATCH), shall come only from the following sources:

- A. compressed air stored in the pneumatic system that has been charged in compliance with R79 and R80,
- B. a change in the altitude of the ROBOT center of gravity,
- C. storage achieved by deformation of ROBOT parts,

D. closed-loop COTS pneumatic (gas) shocks, and

E. air-filled (pneumatic) wheels.

R36 The one (1) ROBOT battery, a single pair of Anderson Power Products (or APP) 2-pole SB type connectors, the one (1) main 120-amp (120A) circuit breaker (Cooper Bussman P/N: CB185-120), and the one (1) Cross The Road Electronics Power Distribution Panel (PDP, P/N: am-2856, 217-4244) shall be connected with 6 AWG wire or larger, with no additional devices or modifications, as shown in [Figure 4-10](#).

Figure 4-10: Main Power Distribution

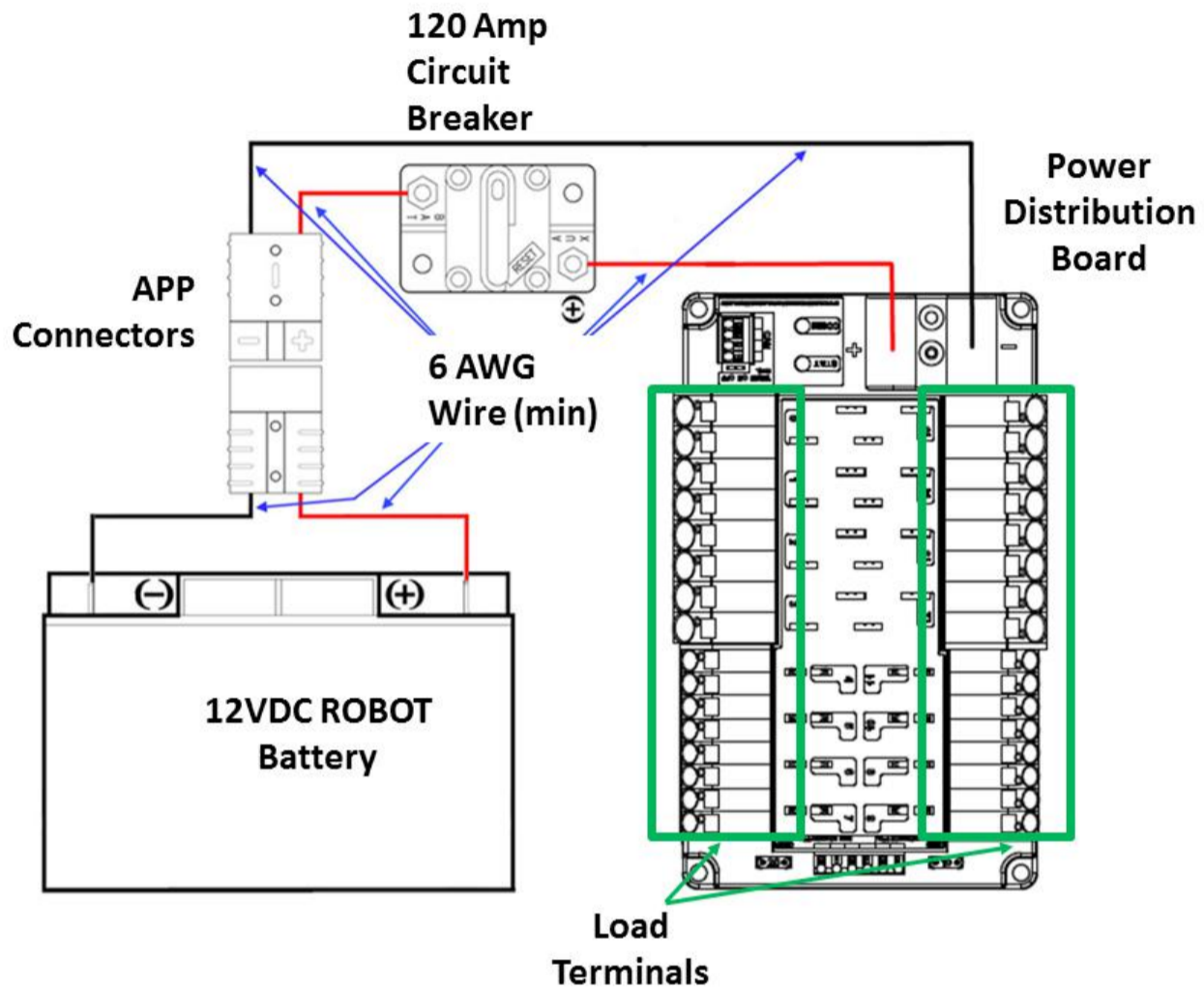

“SB type” refers to SB type only (e.g. SB-50, SB-120, etc.), not SBS or any other part type beginning with SB. All batteries supplied by *FIRST* (such as Spare Parts and international batteries) will have a Red or Pink SB50 connector installed which may not be removed.

The pink connectors included in the 2016 KOP mate with the Red SB50 connector.

R37 All circuits, with the exceptions of those listed in [R42](#) and [R44](#), must connect to, and have power sourced solely by, a single protected 12VDC WAGO connector pair (i.e. the Load Terminals, as shown in [Figure 4-10](#)) not the M6 cap screws.

R38 All wiring and electrical devices, including all Control System COMPONENTS, shall be electrically isolated from the ROBOT frame. The ROBOT frame must not be used to carry electrical current.

R38 is checked by observing a $>3k\Omega$ resistance between either the (+) or (-) post within the APP connector that is attached to the PDP and any point on the ROBOT.

The Victor-SP and Talon-SRX motor controller cases are electrically isolated. They may be mounted directly to ROBOT frame components.

The Axis 206 camera has a grounded enclosure. Under **R38** (and for their protection), it is required that they be electrically isolated from the ROBOT frame when installed on the ROBOT.

R39 The 120A circuit breaker must be quickly accessible from the exterior of the ROBOT. This is the only 120A circuit breaker allowed on the ROBOT.

It is strongly recommended that the 120A circuit breaker location be clearly and obviously labeled so it can be easily found by FIELD staff during a MATCH.

R40 The PDP and all circuit breakers must be easily visible for Inspection.

R41 Any active electrical item that is not an actuator (specified in R29) or core Control System item (specified in R66) is considered a CUSTOM CIRCUIT. CUSTOM CIRCUITS shall not produce voltages exceeding 24V.

R42 The roboRIO power input must be connected to the dedicated supply terminals on the PDP shown in [Figure 4-11](#). No other electrical load shall be connected to these terminals.

Figure 4-11: roboRIO Power Connections

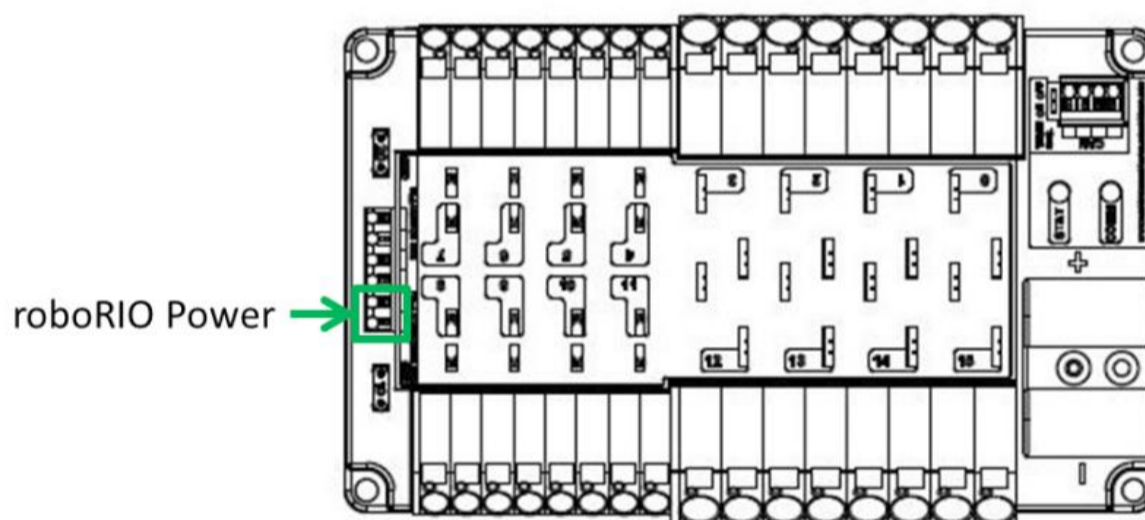

R43 The Wireless Bridge power must be supplied directly by the 12V 2A output of a Cross the Road Electronics Voltage Regulator Module (VRM) (P/N: am-2857, 217-4245) and must be the only load connected to those terminals.

Figure 4-12: Radio Power Connection

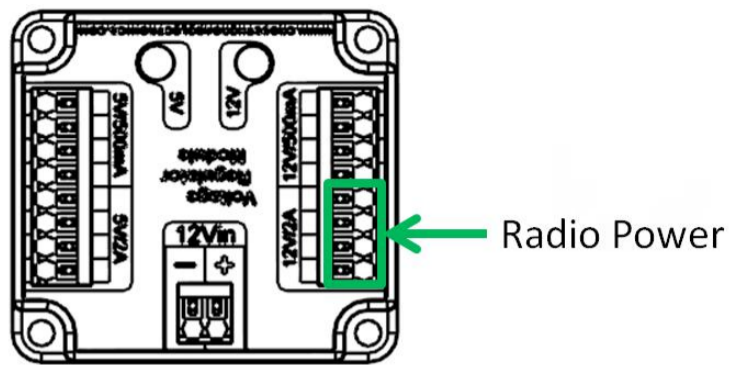

Note that this wiring is different from the wiring for the radio used in 2015. When using a 2015 VRM with the OM5P-AN radio, the radio should be connected as described above, not to the terminals labeled "Radio".

Note that this prohibits using any POE Injector device to power the radio, but does not prohibit using any PASSIVE CONDUCTORS to inject the VRM power into an Ethernet cable plugged into the radio port labeled "18-24v POE".

- R44** The VRM supplying power to the Wireless Bridge per [R43](#) must be connected to the designated supply terminals at the end of the PDP, and not the main WAGO connectors along the sides of the PDP as shown in [Figure 4-13](#). With the exception of a single Cross the Road Electronics Pneumatics Control Module (PCM, P/N: am-2858), no other electrical load shall be connected to these PDP terminals.

Figure 4-13: VRM/PCM Power Connection

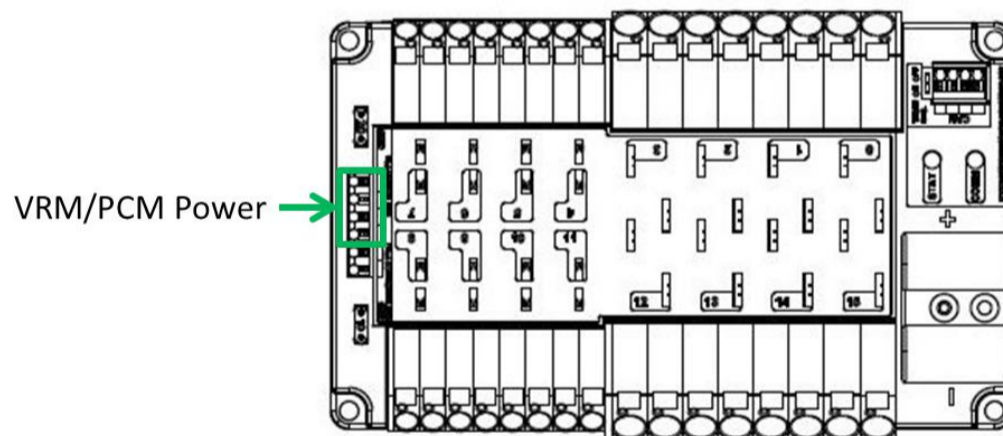

Please reference [Wiring the 2016 FRC Control System](#) for Wireless Bridge wiring information.

R45 Only one wire shall be connected to each WAGO connector on the PDP.

If multi-point distribution of circuit power is needed (e.g. to provide power to multiple PCMs and/or VRMs from one 20A circuit), then all incoming wires may be appropriately spliced into the main lead (e.g. using an insulated terminal block, crimped splice or soldered wire splice), and the single main lead inserted into the WAGO connector to power the circuit.

R46 The only circuit breakers permitted for use in the PDP are:

- A. Snap Action VB3-A Series, terminal style F57
- B. Snap Action MX5-A40

R47 The fuses in the PDP shall only be replaced with functionally identical fuses (mini automotive blade fuses with values matching those printed on the PDP)

R48 Each branch circuit must be protected by one and only one circuit breaker on the PDP per [Table 4-2](#). No other electrical load can be connected to the breaker supplying this circuit.

Table 4-2: Branch Circuit Protection

Branch Circuit	Circuit Breaker Value	Quantity Allowed Per Breaker
Motor Controller	Up to 40A	1
CUSTOM CIRCUIT	Up to 40A	1
Fans permitted per Table 4-1 and not already part of COTS computing devices	Up to 20A	No limit
Relay Module	Up to 20A	1
PCM – with compressor	20A	1
Additional VRM (non-radio)	20A	3 total
Additional PCM (non-compressor)		

[R48](#) does not prohibit the use of smaller value breakers in the PDP or any fuses or breakers within CUSTOM CIRCUITS for additional protection.

R49 All circuits shall be wired with appropriately sized insulated wire:

Table 4-3: Legal Wire Size

Application	Minimum Wire Size
31 – 40A protected circuit	12 AWG (2.052mm)
21 – 30A protected circuit	14 AWG (1.628mm)
6 – 20A protected circuit	18 AWG (1.024mm)
Between the PDP dedicated terminals and the VRM or PCM	
Compressor outputs from the PCM	22 AWG (0.645mm)
Between the PDP and the roboRIO	
VRM 2A circuits	
≤5A protected circuit	26 AWG (0.404mm)
roboRIO PWM port outputs	
SIGNAL LEVEL circuits (i.e. circuits which draw ≤1A continuous and have a source incapable of delivering >1A, including but not limited to roboRIO non-PWM outputs, CAN signals, PCM Solenoid outputs, VRM 500mA outputs and Arduino outputs)	28 AWG (0.321mm)

Wires that are recommended by the device manufacturer or originally attached to legal devices are considered part of the device and by default legal. Such wires are exempt from [R49](#).

R50 Branch circuits may include intermediate elements such as COTS connectors, splices, COTS flexible/rolling/sliding contacts, and COTS slip rings, as long as the entire electrical pathway is via appropriately gauged/rated elements.

R51 All non-SIGNAL LEVEL wiring with a constant polarity (i.e., except for outputs of relay modules, motor controllers, or sensors) shall be color-coded along their entire length from the manufacturer as follows:

- A. Red, yellow, white, brown, or black-with-stripe on the positive (e.g. +24VDC, +12VDC, +5VDC, etc.) connections
- B. Black or blue for the common or negative side (-) of the connections.

Wires that are originally attached to legal devices are considered part of the device and by default legal. Such wires are exempt from [R51](#).

R52 With the exception of servos, fans, or hard drive motors permitted in [R29](#), each actuator must be controlled by a power regulating device. The only power regulating devices for actuators permitted on the ROBOT include:

- A. Motor Controllers
 - i. Jaguar Motor Controller (P/N: MDL-BDC, MDL-BDC24, and 217-3367)
 - ii. SD540 Motor Controller (P/N: SD540x1, SD540x2, SD540x4, SD540Bx1, SD540Bx2, SD540Bx4)
 - iii. Spark Motor Controller (P/N: REV-11-1200)
 - iv. Talon Motor Controller (P/N: CTRE_Talon, CTRE_Talon_SR, and am-2195)
 - v. Talon SRX Motor Controller (P/N: 217-8080, am-2854, 14-838288), equipped with firmware version 0.28 or newer if using via PWM. See [R70](#) if using via CAN.
 - vi. Victor 884 Motor Controller (P/N: VICTOR-884-12/12)
 - vii. Victor 888 Motor Controller (P/N: 217-2769)
 - viii. Victor SP Motor Controller (P/N: 217-9090, am-2855, 14-868380)

B. Relay Modules

- i. Spike H-Bridge Relay (P/N: 217-0220 and SPIKE-RELAY-H)

C. Pneumatics controllers

- i. Pneumatics Control Module (P/N: am-2858, 217-4243)

Please see the [Talon User Guide](#) for more information about the Talon SRX firmware update, determining the firmware on your Talon SRX, and instructions on how install.

R53 Each power regulating device may control electrical loads per [Table 4-4](#). Unless otherwise noted, each power regulating device shall control one and only one electrical load.

Table 4-4: Legal Power Regulating Device Use

Electrical Load	Motor Controller	Relay Module	Pneumatics Controller
CIM AndyMark 9015 WCP RS775 Pro VEX BAG/MiniCIM BaneBots motors	Yes	No	No
Automotive Window/Door/Windshield Wiper/Seat/Throttle Motors AndyMark PG Snow-Blower Motor	Yes Up to 2 per controller	Yes	No
Compressor	No	Yes	Yes
Pneumatic Solenoid Valves	No	Yes*	Yes (1 per channel)
Electric Solenoids	No	Yes*	Yes (1 per channel)
CUSTOM CIRCUITS	Yes	Yes*	Yes (1 per channel)

*Multiple low-load, pneumatic solenoid valves, electric solenoids or CUSTOM CIRCUITS may be connected to a single relay module. This would allow one (1) relay module to drive multiple pneumatic actions or multiple CUSTOM CIRCUITS. No other electrical load can be connected to a relay module used in this manner.

R54 Servos must be connected only to the PWM ports on the roboRIO, either directly or through the PWM ports on a WCP Spartan Sensor Board. They must not be connected to the MXP, motor controllers, or relay modules.

R55 CUSTOM CIRCUITS shall not directly alter the power pathways between the ROBOT battery, PDP, motor controllers, relays, motors and actuators (per R28), pneumatic solenoid valves, or other elements of the ROBOT control system (items explicitly mentioned in [R66](#)). Custom high impedance voltage monitoring or low impedance current monitoring circuitry connected to the ROBOT'S electrical system is acceptable, if the effect on the ROBOT outputs is inconsequential.

A noise filter may be wired across motor leads or PWM leads. Such filters will not be considered CUSTOM CIRCUITS and will not be considered a violation of [R55](#) or [R73](#).

Acceptable signal filters must be fully insulated and must be one of the following:

- A. A one microfarad (1 μ F) or less, non-polarized, capacitor may be applied across the power leads of any motor on your ROBOT (as close to the actual motor leads as reasonably possible).
- B. A resistor may be used as a shunt load for the PWM control signal feeding a servo.

4.10 Control, Command & Signals System

R56 ROBOTS must be controlled via one (1) programmable National Instruments roboRIO (P/N: am3000), with image version FRC_2016_v19 and firmware v3.0.0.

There are no rules that prohibit co-processors, provided commands originate from the roboRIO to configure, enable, and specify all operating points for all power regulating devices. This includes motor controllers legally wired to the CAN-bus.

R57 One (1) OpenMesh Wireless Bridge (P/N: OM5P-AN), that has been configured with the appropriate encryption key for your team number at each event, is the only permitted device for communicating to and from the ROBOT during the MATCH.

The D-Link DAP1522 radio distributed from 2011-2015 is not legal for the 2016 *FIRST* Robotics Competition unless the wireless functionality is disabled.

R58 The Wireless Bridge must be connected to the roboRIO Ethernet port (either directly or via a CAT5 Ethernet pigtail).

R59 Ethernet-connected COTS devices or CUSTOM CIRCUITS may connect to any remaining Ethernet port on the Wireless Bridge but must not transmit or receive UDP packets using ports 1100-1200 with the exception of ports 1130 and 1140.

R60 Communication between the ROBOT and the OPERATOR CONSOLE is restricted as follows:

A. Network Ports:

- i. TCP 1180: Camera data from the roboRIO to the Driver Station (DS) when the camera is connected the roboRIO via USB, bi-directional.
- ii. TCP 1735: SmartDashboard, bi-directional
- iii. UDP 1130: Dashboard-to-ROBOT control data, uni-directional
- iv. UDP 1140: ROBOT-to-Dashboard status data, uni-directional
- v. HTTP 80: Camera connected via switch on the ROBOT, bi-directional
- vi. HTTP 443: Camera connected via switch on the ROBOT, bi-directional
- vii. UDP/TCP 554: Real-Time Streaming Protocol for h.264 camera streaming, bi-directional
- viii. UDP/TCP 5800-5810: Team Use, bi-directional

Teams may use these ports as they wish if they do not employ them as outlined above (i.e. TCP 1180 can be used to pass data back and forth between the ROBOT and the DS if the Team chooses not to use the camera on USB).

B. Bandwidth: no more than 7 Mbits/second.

Note that, for 2016, the 7Mbit limit will be strictly enforced by the Wireless Bridge.

The [FMS Whitepaper](#) has more details on how to check and optimize bandwidth usage.

While *FIRST* makes every effort to provide a wireless environment that allows teams access to a full 7Mbits/second data rate (with about 100Kbit used for ROBOT control and status), at some events wireless conditions may not accommodate this.

- R61** The roboRIO, Driver Station software, and Wireless Bridge must be configured to correspond to the correct Team number, per the procedures defined in [Getting Started with the 2016 Control System](#).
- R62** All signals must originate from the OPERATOR CONSOLE and be transmitted to the ROBOT via the ARENA Ethernet network.
- R63** No form of wireless communication shall be used to communicate to, from, or within the ROBOT, except those required per [R57](#) and [R62](#) (e.g. radio modems from previous *FIRST* competitions and active Bluetooth devices are not permitted on the ROBOT during competition).

Devices that employ signals in the visual spectrum (e.g. cameras) and non-RF sensors that don't receive human-originated commands (e.g. "beam break" sensors or IR sensors on the ROBOT used to detect FIELD elements) aren't wireless communication devices and thus R63 doesn't apply.

- R64** The Wireless Bridge must be mounted on the ROBOT such that the diagnostic lights are visible to ARENA personnel.

Teams are encouraged to mount the wireless bridge away from noise generating devices such as motors, PCM(s), and VRM(s).

- R65** ROBOTS must use at least one (1), but no more than two (2) diagnostic ROBOT Signal Lights (RSL) (P/N: 855PB-B12ME522).

Any RSL must be:

- A. mounted on the ROBOT such that it is easily visible while standing three (3) ft in front of the ROBOT,
- B. connected to the "RSL" supply terminals on the roboRIO,
- C. wired for solid light operation, by placing a jumper between the "La" and "Lb" terminals on the light per [Figure 4-14](#).

Please see [Wiring the 2016 FRC Control System](#) for connection details.

Figure 4-14: Jumper on RSL

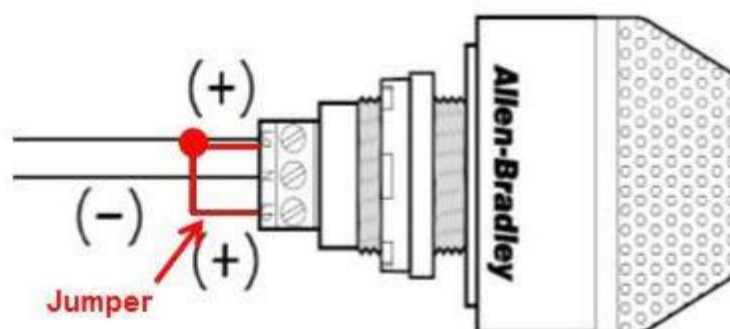

- R66** The Driver Station software, roboRIO, Power Distribution Panel, Pneumatics Control Modules, Voltage Regulator Modules, RSL, 120A breaker, motor controllers, relay modules, Wireless Bridge, and batteries shall not be tampered with, modified, or adjusted in any way (tampering includes drilling, cutting, machining, rewiring, disassembling, etc.), with the following exceptions:

Please note that the Driver Station application is a separate application from the Dashboard. The Driver Station software may not be modified, while teams are expected to customize their Dashboard code.

- A. User programmable code in the roboRIO may be customized.
- B. Motor controllers may be calibrated as described in owner's manuals.

- C. Fans may be attached to motor controllers and may be powered from the power input terminals.
- D. If powering the compressor, the fuse on a Spike H-Bridge Relay may be replaced with a 20A Snap-Action circuit breaker.
- E. Wires, cables, and signal lines may be connected via the standard connection points provided on the devices.
- F. Fasteners (including adhesives) may be used to attach the device to the OPERATOR CONSOLE or ROBOT or to secure cables to the device.
- G. Thermal interface material may be used to improve heat conduction.
- H. Labeling may be applied to indicate device purpose, connectivity, functional performance, etc.
- I. Jumpers may be changed from their default location.
- J. Limit switch jumpers may be removed from a Jaguar motor controller and a custom limit switch circuit may be substituted.
- K. Device firmware may be updated with manufacturer supplied firmware.
- L. Integral wires on the Victor SP or Talon SRX may be cut, stripped, and/or connectorized.
- M. Devices may be repaired, provided the performance and specifications of the device after the repair are identical to those before the repair.
- N. The cover may be removed from the Talon SRX data port.

Please note that while repairs are permitted per the *FIRST* Robotics Competition *Game Manual*, the allowance is independent of any manufacturer's warranty. Teams make repairs at their own risk and should assume that any warranty or RMA options are forfeited. Be aware that diagnosing and repairing COMPONENTS such as these can be difficult.

- R67** Neither 12VDC power nor relay module or motor controller outputs shall be directly connected to the roboRIO (with the exception of the designated 12VDC input).
- R68** Every relay module, servo, and PWM motor controller shall be connected to a corresponding port (relays to Relay ports, servos and PWM controllers to PWM ports) on the roboRIO (either directly or through a WCP Spartan Sensor Board) or via a legal MXP connection (per [R69](#)). They shall not be controlled by signals from any other source.
- R69** If a motor is controlled via the MXP, its power regulating device must be connected by one of the following methods:
 - A. directly to any PWM pins,
 - B. via a network of PASSIVE CONDUCTORS used to extend the PWM pins, or
 - C. via one approved ACTIVE DEVICE:
 - i. Kauai Labs navX MXP
 - ii. RCAL MXP Daughterboard
 - iii. REV Robotics RIOduino
 - iv. REV Robotics Digit Board
 - v. WCP Spartan Sensor Board

A PASSIVE CONDUCTOR is any device or circuit whose capability is limited to the conduction and/or static regulation of the electrical energy applied to it (e.g. wire, splices, connectors, printed wiring board, etc.).

An ACTIVE DEVICE is any device capable of dynamically controlling and/or converting a source of electrical energy by the application of external electrical stimulus.

The “network of PASSIVE CONDUCTORS” only applies to the pins being used for PWM output to motors or servos. This means that connecting an ACTIVE DEVICE, such as a sensor to one MXP pin does not prevent other MXP pins from being used in accordance with [R69-B](#).

R70 Each Jaguar or Talon SRX must be controlled with signal inputs sourced from the roboRIO and passed via either a PWM (wired per [R68](#)) or CAN-bus (either directly or daisy-chained via another CAN-bus device) signal, but both shall not be wired simultaneously on the same device. If the CAN-bus configuration is used, the firmware on the device must be updated to at least the following versions:

- A. Grey Jaguars – v109
- B. Black Jaguars – v109
- C. Talon SRX – v1.01. (no greater than 10.0)

As long as the CAN bus is wired legally so that the heartbeat from the roboRIO is maintained, all closed loop control features of the Jaguar or Talon SRX motor controller may be used. (That is, commands originating from the roboRIO to configure, enable, and specify an operating point for all Jaguar or Talon SRX closed loop modes fit the intent of [R56](#).)

R71 Each PCM must be controlled with signal inputs sourced from the roboRIO and passed via a CAN-bus connection from the roboRIO (either directly or daisy-chained via another CAN-bus device). The firmware on each PCM must be updated to at least version 1.62.

R72 The PDP CAN interface must be connected to the CAN-bus on the roboRIO (either directly or daisy-chained via another CAN-bus device). The firmware on the PDP must be updated to at least version 1.37.

For documentation on how to wire the CAN-bus connections of the PDP see [Wiring the 2016 FRC Control System](#).

R73 The CAN-bus must be connected to the roboRIO CAN port.

- A. Additional switches, sensor modules, CUSTOM CIRCUITS, third-party modules, etc. may also be placed on the CAN-bus.
- B. No device that interferes with, alters, or blocks communications among the roboRIO and the Jaguars, PDP, PCMs, and/or Talon-SRXs on the bus will be permitted.

Only one wire should be inserted into each Weidmuller CAN connector terminal. For documentation on how to wire the CAN-bus connections of the roboRIO, PCM, PDP and CAN motor controllers, see [Wiring the 2016 FRC Control System](#).

4.11 Pneumatic System

- R74** To satisfy multiple constraints associated with safety, consistency, Inspection, and constructive innovation, no pneumatic parts other than those explicitly permitted in [Section 4.11 Pneumatic System](#) shall be used on the ROBOT.
- R75** All pneumatic items must be COTS pneumatic devices rated by their manufacturers for working pressure of at least 120psi (with the exception of [R77-D](#)).
- R76** All pneumatic COMPONENTS must be used in their original, unaltered condition. Exceptions are as follows:
- A. tubing may be cut,
 - B. wiring for pneumatic devices may be modified to interface with the control system,
 - C. assembling and connecting pneumatic COMPONENTS using the pre-existing threads, mounting brackets, quick-connect fittings, etc.,
 - D. removing the mounting pin from a pneumatic cylinder, provided the cylinder itself is not modified,
 - E. labeling applied to indicate device purpose, connectivity, functional performance, etc.

Do not, for example, paint, file, machine, or abrasively remove any part of a pneumatic COMPONENT – this would cause the part to become a prohibited item. Consider pneumatic COMPONENTS sacred.

- R77** The only pneumatic system items permitted on 2016 *FIRST* Robotics Competition ROBOTS include the items listed below.

- A. Items available in the KOP (except as noted in [R77-K](#)),
- B. Pneumatic pressure vent plug valves functionally equivalent to those provided in the KOP,

Parker valves PV609-2 or MV709-2 are recommended.

- C. Solenoid valves with a maximum 1/8 in. NPT, BSPP, or BSPT port diameter,
- D. Solenoid valves that are rated for a maximum working pressure that is less than 120 psi rating mandated above are permitted, however if employed, an additional pressure relief valve must be added to the low pressure side of the main regulator. The additional relief valve must be set to a lower pressure than the maximum working pressure rating for the solenoid valve,
- E. Additional pneumatic tubing, with a maximum 0.165 in. inside diameter, functionally equivalent to that provided in the KOP,
- F. Pressure transducers, pressure gauges, passive flow control valves (specifically “needle valve”), manifolds, and connecting fittings,
- G. Check and quick exhaust valves, provided that the requirements of [R89](#) are still met.
- H. Shutoff valves which relieve downstream pressure to atmosphere when closed (may also be known as 3-way or 3-way exhausting valves).
- I. Pressure regulators with the outlet pressure adjusted to no more than 60 psi,
- J. Pneumatic cylinders, pneumatic linear actuators, and rotary actuators,
- K. Pneumatic storage tanks (with the exception of White Clippard tanks P/N: AVT-PP-41), and
- L. Compressors compliant with [R79](#).

The following devices are not considered pneumatic devices and are not subject to pneumatic rules (though they must satisfy all other rules):

- A. a device that creates a vacuum
- B. closed-loop COTS pneumatic (gas) shocks
- C. air-filled (pneumatic) wheels

R78 If pneumatic COMPONENTS are used, the following items are required as part of the pneumatic circuit and must be used in accordance with this section, as illustrated in [Figure 4-15](#).

- A. Compressor
- B. Pressure relief valve (Norgren Part Number 16-004-011) connected via legal rigid fittings (e.g. brass, nylon, etc.)
- C. Nason pressure switch, P/N SM-2B-115R/443
- D. At least one Pressure vent plug
- E. “Stored” pressure gauge (upstream from Primary Regulator)
- F. “Working” pressure gauge (downstream from Primary Regulator)
- G. “Working” pressure regulator

Figure 4-15: Pneumatic System Setup

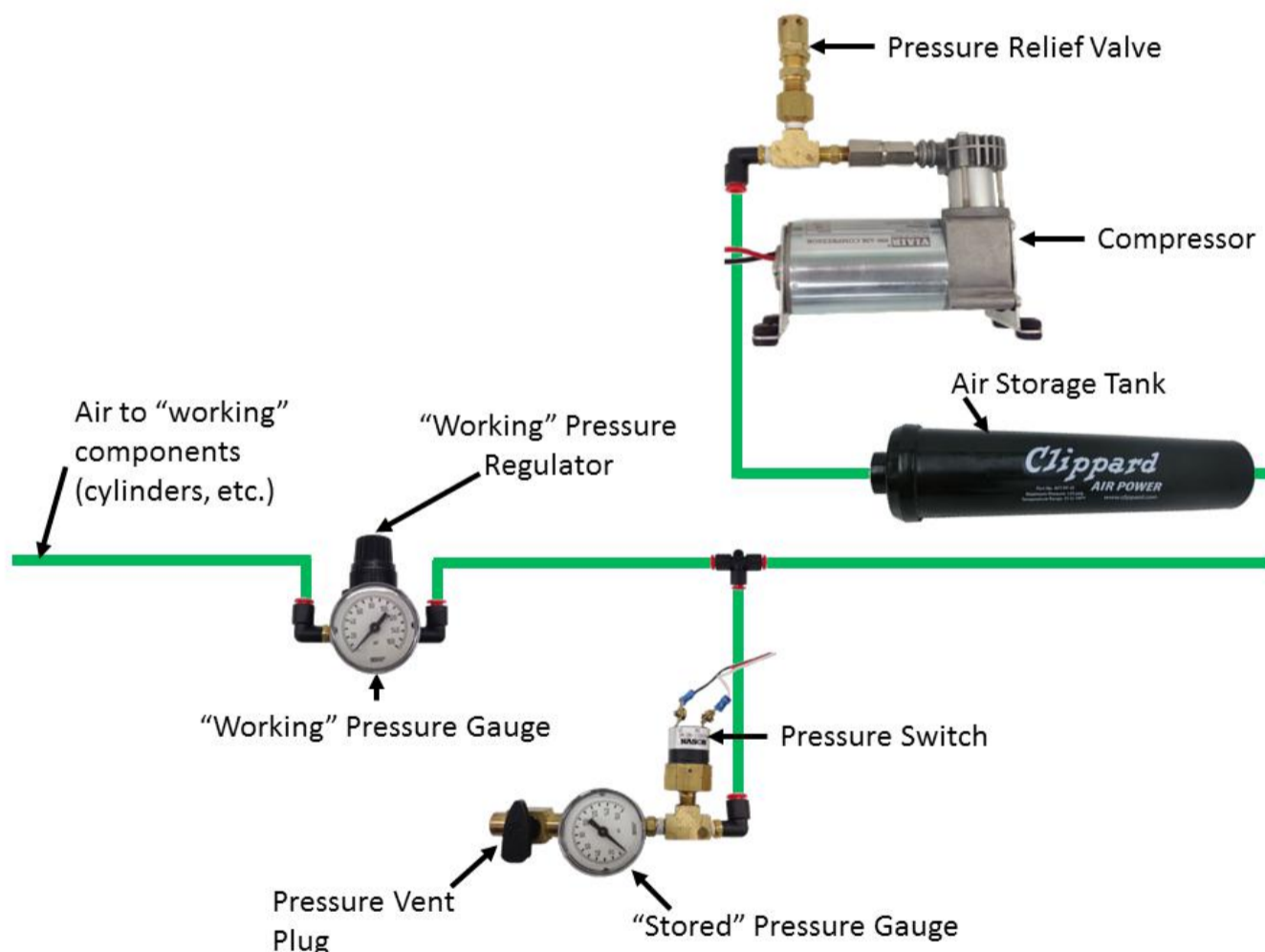

R79 Compressed air on the ROBOT must be provided by one and only one compressor. Compressor specifications must not exceed nominal 1.10 cfm flow rate @ 12VDC.

R80 The compressor (permitted per [R79](#)) may be located off-board, however the compressor must still be controlled and powered by the ROBOT.

The compressor may be mounted on the ROBOT, or it may be left off the ROBOT and used to pre-charge compressed air in storage tanks on the ROBOT provided the additional restrictions of [R85](#) are met.

The intent of this rule is to permit teams to take advantage of the weight savings associated with keeping the compressor off-board. However, using the compressor off-board of the ROBOT does NOT permit non-compliance with any other applicable rules.

- R81** “Stored” air pressure on the ROBOT must be no greater than 120 psi. No stored air pressure intended for the ROBOT may be located off-board the ROBOT.
- R82** “Working” air pressure on the ROBOT must be no greater than 60 psi and must be provided through a single primary adjustable, relieving, pressure regulator.

Norgren regulator P/N: R07-100-RNEA or Monnier P/N: 101-3002-1 recommended.

- R83** Only the compressor, relief valve (P/N: 16-004-011), pressure switch, pressure vent plug, pressure gauge, storage tanks, tubing, pressure transducers, and connecting fittings may be in the high-pressure pneumatic circuit upstream from the regulator.
- R84** Pressure gauges must be placed in easily visible locations upstream and downstream of the regulator to display the “stored” and “working” pressures.
- R85** If the compressor is not included on the ROBOT (under the provisions of [R80](#)) the “Stored” Pressure Gauge and pressure switch may be located on-board ([Figure 4-16](#)) or off-board ([Figure 4-17](#)) (but must be together), provided all other pneumatic rules are satisfied.

Figure 4-16: Off-Board Compressor with On-Board Switch and Gauge

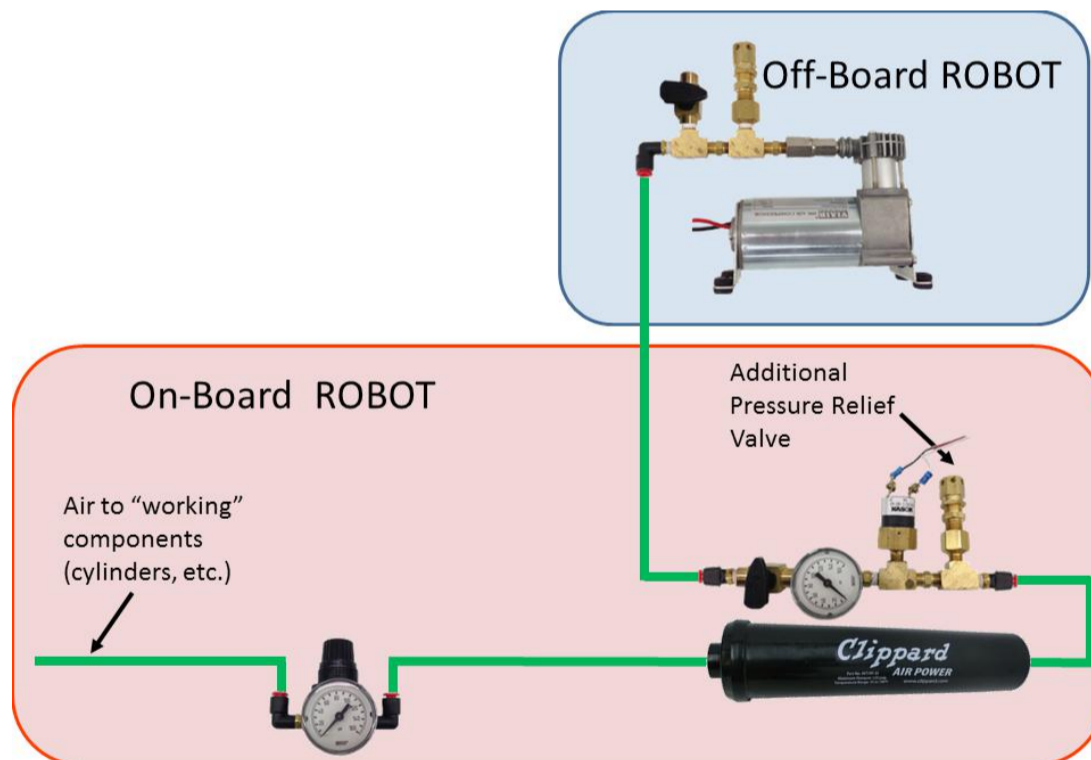

- R86** If the stored pressure gauge is kept off-board the ROBOT with the compressor, then only low-pressure (60 psi or less) “working” air can be stored on the ROBOT. The “working” pressure gauge must be installed on-board the ROBOT at all times ([Figure 4-17](#)).

Figure 4-17: Off-Board Compressor, Switch and Gauge with Additional On-Board Gauge

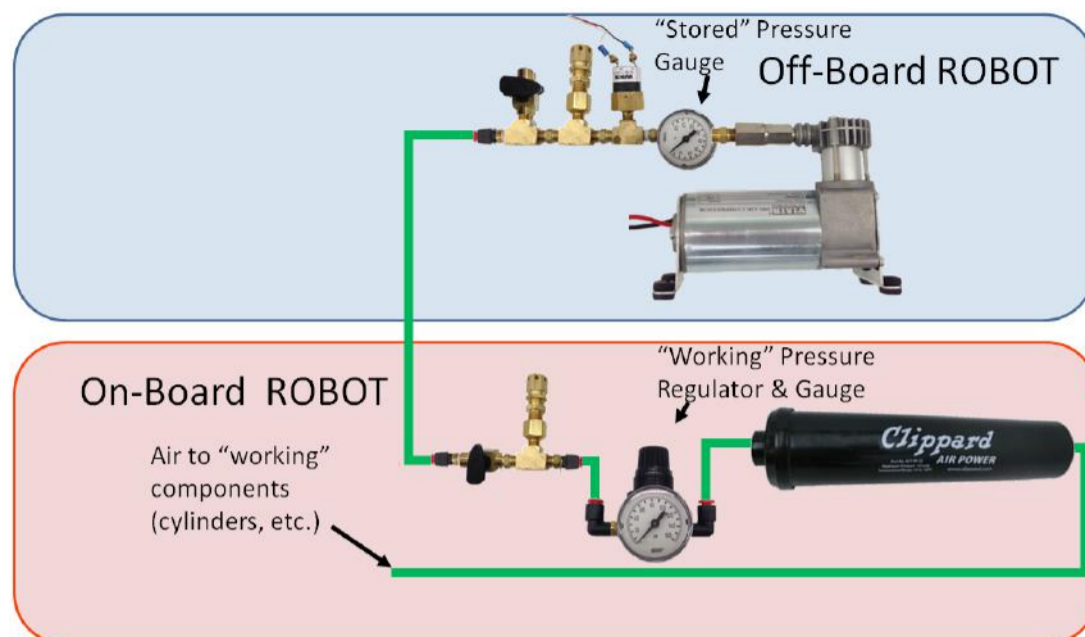

- R87** The relief valve must be attached directly to the compressor or attached by legal hard fittings (e.g. brass, nylon, etc.) connected to the compressor output port. If using an off-board compressor, an additional relief valve must be included on the ROBOT.

If necessary, Teams are required to adjust the relief valve to release air at 125 psi. The valve may or may not have been calibrated prior to being supplied to Teams.

- R88** The pressure switch requirements are:

- It must be Nason P/N: SM-2B-115R/443
- It must be connected to the high-pressure side of the pneumatic circuit (i.e. prior to the pressure regulator) to sense the “stored” pressure of the circuit.
- The two wires from the pressure switch must be connected directly to the pressure switch input of the PCM controlling the compressor or, if controlled using the roboRIO and a Spike relay, to the roboRIO.
- If connected to the roboRIO, the roboRIO must be programmed to sense the state of the switch and operate the relay module that powers the compressor to prevent over-pressuring the system.

- R89** Any pressure vent plug must be:

- connected to the pneumatic circuit such that, when manually operated, it will vent to the atmosphere to relieve all stored pressure in a reasonable amount of time, and
- placed on the ROBOT so that it is visible and easily accessible.

If the compressor is not used on the ROBOT, then an additional pressure vent plug must be connected to the high-pressure portion of the pneumatic circuit off-board the ROBOT with the compressor (see [R80](#)).

- R90** The outputs from multiple valves must not be plumbed together.

4.12 OPERATOR CONSOLE

- R91** The Driver Station software provided on the [National Instruments website](#) is the only application permitted to specify and communicate the operating mode (i.e. Autonomous/Teleop) and operating state (Enable/Disable) to the ROBOT. The Driver Station software must be revision 16.0.2 or newer.

Teams are permitted to use a portable computing device of their choice (laptop computer, PDAs, etc.) to host the Driver Station software while participating in competition MATCHES.

- R92** The OPERATOR CONSOLE, the set of COMPONENTS and MECHANISMS used by the DRIVERS and/or HUMAN PLAYER to relay commands to the ROBOT, must include a graphic display to present the Driver Station diagnostic information. It must be positioned within the OPERATOR CONSOLE so that the screen display can be clearly seen during Inspection and in a MATCH.
- R93** Devices hosting the Driver Station software must only interface with the Field Management System (FMS) via the Ethernet cable provided at the PLAYER STATION (e.g. not through a switch). Teams may connect the FIELD Ethernet cable to their Driver Station device directly via an Ethernet pigtail, or with a single-port Ethernet converter (e.g. docking station, USB-Ethernet converter, Thunderbolt-Ethernet converter, etc.). The Ethernet port on the OPERATOR CONSOLE must be easily and quickly accessible.

Teams are strongly encouraged to use pigtails on the Ethernet port used to connect to the FMS. Such pigtails will reduce wear and tear on the device's port and, with proper strain relief employed, will protect the port from accidental damage.

- R94** The OPERATOR CONSOLE must not exceed 60 in. long by 14 in. deep (excluding any items that are held or worn by the DRIVERS during the MATCH) and may not extend more than 11 ft. 8 in. above the floor.

There is a 54 in. long by 2 in. wide strip of hook-and-loop tape ("loop" side) along the center of the PLAYER STATION support shelf that may be used to secure the OPERATOR CONSOLE to the shelf. See Section 2.3.1.1: PLAYER STATION for details.

- R95** Other than the system provided by the ARENA, no other form of wireless communications shall be used to communicate to, from, or within the OPERATOR CONSOLE.

Examples of prohibited wireless systems include, but are not limited to, active wireless network cards and Bluetooth devices. For the case of *FIRST* Robotics Competition, a motion sensing input device (e.g. Microsoft Kinect) is not considered wireless communication and is allowed.

- R96** OPERATOR CONSOLES shall not be made using hazardous materials, be unsafe, cause an unsafe condition, or interfere with other DRIVE TEAMS or the operation of other ROBOTS.

FIRST®, the *FIRST*® logo, *FIRST*® Robotics Competition, *Coopertition*®, *Gracious Professionalism*® are registered trademarks, and *Sport for the Mind*™ and *STRONGHOLD*SM are common law trademarks, of the United States Foundation for Inspiration and Recognition of Science and Technology (*FIRST*®). ©2016 *FIRST*. All rights reserved.

5

Tournament

5.1	Overview.....	3
5.1.1	MATCH Schedules	3
5.2	Practice MATCHES	4
5.2.1	Schedule.....	4
5.2.2	Filler Line	4
5.3	Qualification MATCHES	4
5.3.1	Schedule.....	4
5.3.2	MATCH Assignment	4
5.3.3	Ranking Score (RS)	5
5.3.4	Qualification Seeding.....	5
5.4	Playoff MATCHES	6
5.4.1	ALLIANCE Selection Process.....	6
5.4.2	BACKUP TEAMS.....	7
5.4.3	Playoff MATCH Bracket.....	7
5.4.4	Playoff Scoring	9

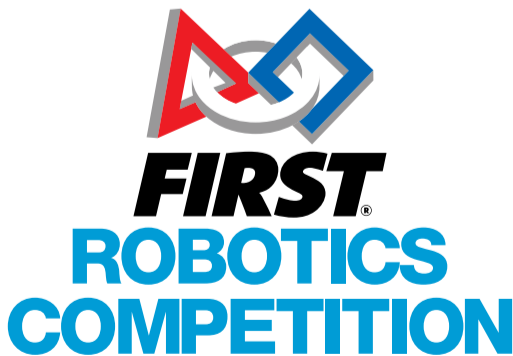

FIRST®, the FIRST® logo, FIRST® Robotics Competition, Coopertition®, Gracious Professionalism® are registered trademarks, and Sport for the Mind™ and FIRST STRONGHOLDSM are common law trademarks, of the United States Foundation for Inspiration and Recognition of Science and Technology (FIRST®). ©2016 FIRST®. All rights reserved.

Official FIRST® Robotics Competition teams and Partners are permitted to make reproductions of this manual for team and Partner use only. Any use, reproduction, or duplication of this manual for purposes other than directly by the team or Partner as part of FIRST® Robotics Competition participation is strictly prohibited without specific written permission from FIRST.

5

Tournament

5.5	Tournament Rules	9
5.5.1	Safety, Security, and Conduct Rules	9
5.5.2	Eligibility and Inspection	11
5.5.3	REFEREE Interaction	15
5.5.4	YELLOW and RED CARDS	15
5.5.5	MATCH Replays	17
5.5.6	TIMEOUT and BACKUP TEAM Rules	17
5.5.7	Pit Crews	19
5.5.8	Measurement	19
5.5.9	Special Equipment Rules	19
5.5.10	Selecting Defenses	20
5.6	Championship Additions and Exceptions	24
5.6.1	Four ROBOT ALLIANCES	24
5.6.2	Championship Pit Crews	25
5.6.3	FIRST Robotics Competition Championship MATCH Bracket	25
5.6.4	TIMEOUTS	27

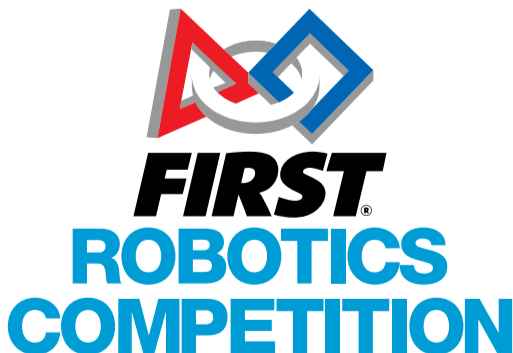

FIRST®, the FIRST® logo, FIRST® Robotics Competition, Coopertition®, Gracious Professionalism® are registered trademarks, and Sport for the Mind™ and FIRST STRONGHOLDSM are common law trademarks, of the United States Foundation for Inspiration and Recognition of Science and Technology (FIRST®). ©2016 FIRST®. All rights reserved.

Official FIRST® Robotics Competition teams and Partners are permitted to make reproductions of this manual for team and Partner use only. Any use, reproduction, or duplication of this manual for purposes other than directly by the team or Partner as part of FIRST® Robotics Competition participation is strictly prohibited without specific written permission from FIRST.

5 TOURNAMENT

*FIRST STRONGHOLD*SM is a medieval tower defender game in which two (2) ALLIANCES of three (3) Teams each select DEFENSES to fortify their OUTER WORKS before competing simultaneously to score points while BREACHING the opponent's OUTER WORKS and CAPTURING the opponent's TOWER.

5.1 Overview

Each 2016 *FIRST* Robotics Competition event is played in a tournament format. Each tournament consists of three sets of MATCHES called "Practice MATCHES" (not necessarily at all District Events), "Qualification MATCHES," and "Playoff MATCHES."

Practice MATCHES provide each Team with an opportunity to operate its ROBOT on the FIELD prior to the start of the Qualification MATCHES.

Qualification MATCHES allow each Team to earn a seeding position that may qualify them for participation in the Playoff MATCHES.

Playoff MATCHES determine the event Champions.

Each MATCH period consists of two (2) minutes and thirty (30) seconds of game play, as well as pre and post-MATCH time for setup and to Reset the ARENA. During ARENA Reset, the ARENA is cleared of ROBOTS and OPERATOR CONSOLES from the MATCH that just ended. The ROBOTS and OPERATOR CONSOLES for the following MATCH must be placed in position and ready to operate before the start of the next MATCH. FIELD STEWARDS will reset the ARENA elements during this time.

If order placement of ROBOTS matters to either or both ALLIANCES, the ALLIANCE must notify the Head REFEREE (an official who is certified by *FIRST* to enforce the rules of *FIRST STRONGHOLD*) during setup for that MATCH. Upon notification, the Head REFEREE will require ALLIANCES to alternate placement of their ROBOTS, starting with the Red ALLIANCE.

5.1.1 MATCH Schedules

A MATCH schedule is used to coordinate MATCHES at an Event. [Figure 5-1](#) details information shown on each Schedule.

Figure 5-1: Sample MATCH Schedule

Qualification Match Schedule

Event Name								
Matches Per Team		10	ALLIANCE Red or Blue			PLAYER STATION number 1, 2, or 3		
Time	Description	Match	Blue 1	Blue 2	Blue 3	Red 1	Red 2	Red 3
Thu 2:30	Qualification 1 (A)	1	1	2	3	4	5	6
Thu 2:37	Qualification 2 (A)	2	7	8	9	10	11*	12
Thu 2:44	Qualification 3 (A)	3	13	14	15*	16	17	18

Labels and arrows in the diagram point to: MATCH Start Time (Thu 2:30), MATCH Type (Qualification 1 (A)), MATCH Number (1), ALLIANCE Red or Blue (Blue 1-3, Red 1-3), PLAYER STATION number 1, 2, or 3 (1-18), and SURROGATE MATCH indicator (15* and 11*).

5.2 Practice MATCHES

5.2.1 Schedule

Practice MATCHES are played on the first day of each event. The Practice MATCH schedule is available as soon as possible, but no later than the start of Practice MATCHES. Practice MATCHES are randomly assigned, and teams may not switch scheduled Practice MATCHES. Each Team is assigned an equal number of Practice MATCHES unless the number of Teams multiplied by number of Practice MATCHES is not divisible by six. In this case, the FIELD Management System (FMS) randomly selects some Teams to play an extra Practice MATCH.

Practice MATCHES are not guaranteed at District Events.

5.2.2 Filler Line

A Filler Line is used to fill open slots at events that employ scheduled Practice MATCHES, or all slots at events with an open Practice MATCH schedule.

Teams wanting additional Practice MATCHES may join the Filler Line if the criteria listed below are met. Teams from the Filler Line are used on a first come, first served basis to fill empty spots in Practice MATCHES left by other Teams that do not report to Queueing. The number of Teams in the Filler Line is dependent upon space at venues. The criteria for joining the Filler Line are as follows:

- A. ROBOTS in the Filler Line must have passed Inspection (this requirement may be waived for events with open Practice MATCH schedules);
- B. DRIVE TEAMS must join the Filler Line with their ROBOT;
- C. Teams may not work on their ROBOT while in the Filler Line;
- D. Teams may not occupy more than one spot in the Filler Line; and
- E. If a Team is queued up for their Practice MATCH, they may not also join the Filler Line.

5.3 Qualification MATCHES

5.3.1 Schedule

The Qualification MATCH schedule is made available as soon as possible, but no later than one (1) hour before Qualification MATCHES are scheduled to begin. Each Qualification schedule consists of a series of rounds in which each team plays one (1) MATCH per round.

5.3.2 MATCH Assignment

FMS assigns each Team two (2) ALLIANCE partners for each Qualification MATCH using a predefined algorithm, and teams may not switch Qualification MATCH assignments. The algorithm employs the following criteria, listed in order of priority:

1. Maximize time between each MATCH played for all Teams
2. Minimize the number of times a Team plays opposite any Team

3. Minimize the number of times a Team is allied with any Team
4. Minimize the use of SURROGATES (Teams randomly assigned by the FMS to play an extra Qualification MATCH)
5. Provide even distribution of MATCHES played on Blue and Red ALLIANCE

All Teams are assigned the same number of Qualification MATCHES, equal to the number of rounds, unless the number of Teams multiplied by number of MATCHES is not divisible by six. In this case, the FMS randomly selects some Teams to play an extra MATCH. For the purpose of seeding calculations, those Teams are designated as SURROGATES for the extra MATCH. If a Team plays a MATCH as a SURROGATE, it is indicated on the MATCH schedule, it is always their third Qualification MATCH, and the outcome of the MATCH has no affect on the Team's ranking. YELLOW and RED CARDS assigned to SURROGATES do carry forward to subsequent MATCHES.

5.3.3 Ranking Score (RS)

Ranking Points are units credited to a Team based on their ALLIANCES' performance in Qualification MATCHES. Ranking Points are awarded to each eligible Team at the completion of each Qualification MATCH:

- A. Each Team on the winning ALLIANCE receives two (2) Ranking Points.
- B. Each Team on the losing ALLIANCE receives zero (0) Ranking Points.
- C. In the event of a tied score, all Teams receive one (1) Ranking Point.
- D. Each Team on an ALLIANCE that CAPTURES a TOWER receives one (1) Ranking Point.
- E. Each Team on an ALLIANCE that BREACHES the OUTER WORKS receives one (1) Ranking Point.

Exceptions to A-E are as follows:

- F. A SURROGATE receives zero (0) Ranking Points.
- G. A DISQUALIFIED Team, as determined by the Head REFEREE, receives zero (0) Ranking Points in a Qualification MATCH or causes their ALLIANCE to receive zero (0) MATCH points in a Playoff MATCH.
- H. A "no-show" Team is DISQUALIFIED from that MATCH. A Team is declared a no-show if no member of the DRIVE TEAM is in the CASTLE or the SPY BOX at the start of the MATCH.

The total number of Ranking Points earned by a Team throughout their Qualification MATCHES is their Ranking Score (RS).

5.3.4 Qualification Seeding

All Teams participating in the Tournament are seeded during the Qualification MATCHES. If the number of Teams in attendance is 'n', they are seeded '1' through 'n', with '1' being the highest seeded Team and 'n' being the lowest seeded Team.

FMS ranks all Teams in decreasing order, using the following sorting criteria:

Table 5-1: Qualification MATCH Ranking Criteria

Order Sort	Criteria
1 st	Ranking Score
2 nd	Cumulative sum of AUTO points
3 rd	Cumulative sum of scored SCALE and CHALLENGE points
4 th	Cumulative sum of High and Low GOAL points from AUTO and TELEOP
5 th	Cumulative sum of CROSSED UNDAMAGED DEFENSE points (AUTO and TELEOP)
6 th	Random sorting by the FMS

5.4 Playoff MATCHES

At the end of the Qualification MATCHES, the top eight (8) seeded Teams become the ALLIANCE Leads. The top seeded ALLIANCES are designated, in order, ALLIANCE One, ALLIANCE Two, etc., down to ALLIANCE Eight. Using the ALLIANCE selection process described below, each ALLIANCE Lead chooses two (2) other Teams to join their ALLIANCE.

If a Team declines the ALLIANCE Lead position or doesn't send a student representative for ALLIANCE selection, they are ineligible to participate in the Playoff Tournament. If the declining/absent Team would have been an ALLIANCE Lead, all lower ranked ALLIANCE Leads are promoted one spot. The next highest-seeded Team moves up to become the ALLIANCE Eight Lead.

5.4.1 ALLIANCE Selection Process

Each Team chooses a student Team representative who proceeds to the ARENA at the designated time (typically before the lunch break on the final day of the event) to represent their Team. The designated student representative from each ALLIANCE in a Playoff MATCH is called the ALLIANCE CAPTAIN.

The ALLIANCE selection process consists of two (2) rounds during which each ALLIANCE CAPTAIN invites a Team seeded below them in the standings to join their ALLIANCE. The invited Team must not already have declined an invitation.

Round 1: In descending order (ALLIANCE One to ALLIANCE Eight), each ALLIANCE CAPTAIN invites a single Team. The invited Team's representative steps forward and either accepts or declines the invitation.

If the Team accepts, it becomes a member of that ALLIANCE. If an invitation from a top eight ALLIANCE to another ALLIANCE Lead is accepted, all lower ALLIANCE Leads are promoted one spot. The next highest-seeded, unselected Team moves up to become the ALLIANCE Eight Lead.

If the Team declines, that Team is not eligible to be picked again or to be a BACKUP TEAM (see [Section 5.4.2 BACKUP TEAMS](#)), and the ALLIANCE CAPTAIN extends another invitation to a different Team. If an invitation from a top eight ALLIANCE to another ALLIANCE Lead is declined, the declining Team may still invite Teams to join their ALLIANCE; however, it cannot accept invitations from other ALLIANCES.

The process continues until ALLIANCE Eight makes a successful invitation.

Round 2: The same method is used for each ALLIANCE CAPTAIN'S second choice except the selection order is reversed, with ALLIANCE Eight picking first and ALLIANCE One picking last. This process results in eight (8) ALLIANCES of three (3) Teams each.

Of the remaining eligible Teams, the highest seeded Teams must either accept or decline to be included in a pool of available Teams until there are up to eight (8) Teams that accept to be added into the pool. Field staff will coordinate the assembly of this BACKUP pool immediately after the top ranked ALLIANCE has made their final pick. If a Team is not available to accept inclusion in the BACKUP pool, it will be assumed they have declined the invitation.

5.4.2 BACKUP TEAMS

In the Playoff MATCHES, it may be necessary for an ALLIANCE to replace one of its members due to a faulty ROBOT. ROBOT faults include but are not limited to:

1. Damaged mechanicals,
2. Electrical issues,
3. Software problems

In this situation, the ALLIANCE CAPTAIN has the option to bring in only the highest seeded Team from the pool of available Teams to join its ALLIANCE. The Team who's ROBOT and DRIVE TEAM replaces another ROBOT and DRIVE TEAM on an ALLIANCE during the Playoff MATCHES is called the BACKUP TEAM.

The resulting ALLIANCE is then composed of four (4) Teams. The replaced Team remains a member of the ALLIANCE for awards, but cannot return to play, even if their ROBOT is repaired.

Each ALLIANCE is allotted one (1) BACKUP TEAM Coupon during the Playoff MATCHES. If a second ROBOT from the ALLIANCE becomes inoperable, then the ALLIANCE must play the following MATCHES with only two (2) (or even one (1)) ROBOTS.

Example: Three (3) Teams, A, B and C, form an ALLIANCE going into the Playoff MATCHES. The highest seeded Team not on one of the eight (8) ALLIANCES is Team D. During one of the Playoff MATCHES, Team C's ROBOT suffers damage to its mechanical arm. The ALLIANCE CAPTAIN decides to bring in Team D to replace Team C. Team C and their ROBOT are not eligible to play in any subsequent Playoff MATCHES. The new ALLIANCE of Teams A, B, and D are successful in advancing to the Finals and win the event. Teams A, B, C, and D are all recognized as members of the Winning Alliance and receive awards.

In the case where a BACKUP TEAM is part of the Winning or Finalist ALLIANCE, there will be a four (4)-Team Winning or Finalist ALLIANCE.

5.4.3 Playoff MATCH Bracket

The Playoff MATCHES take place following the completion of the Qualification MATCHES and the ALLIANCE selection process. Playoff MATCHES are played in a bracket format as shown in [Figure 5-2](#).

ALLIANCE Leads will always be assigned to the center PLAYER STATION, the first pick will be assigned to the station to their left while they're facing the FIELD, and the second pick will be assigned to their right while they're facing the FIELD. If a BACKUP TEAM is in play, they will be assigned to the PLAYER STATION that was assigned to the DRIVE TEAM they're replacing.

Figure 5-2: Playoff MATCH Bracket

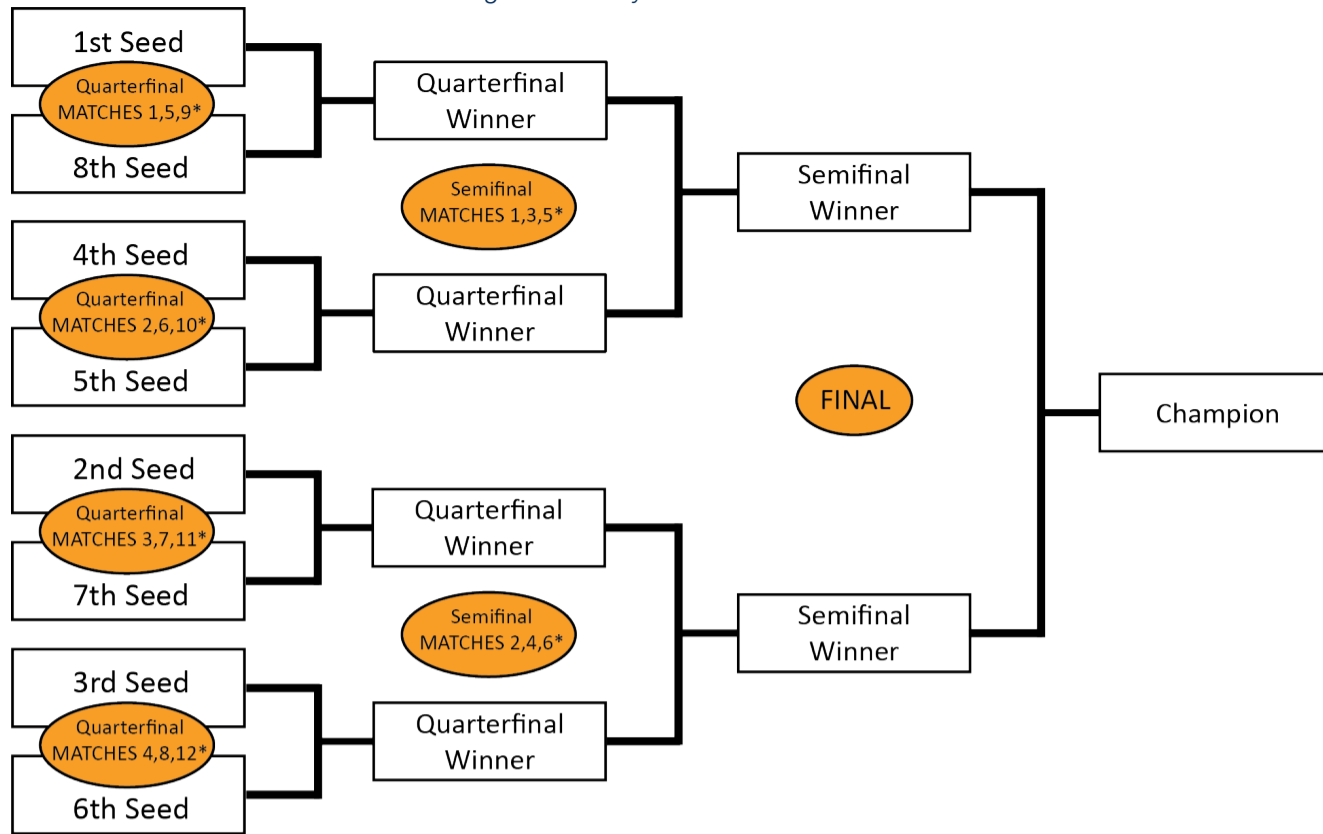

*If necessary

In order to allow time between MATCHES for all ALLIANCES and the selection of DEFENSES, the order of play is as follows:

Table 5-2: Playoff Order and Audience DEFENSE Selection Timing

Quarterfinal Round 1	Quarterfinal Round 2	Quarterfinal Round 3	Semifinals	Finals
Audience selects DEFENSES per 5.5.10.1 ¹	Audience selects DEFENSES per 5.5.10.1 ¹	Same Group selection as Quarterfinal Round 2	Audience selects DEFENSES per 5.5.10.1 ¹	Audience selects DEFENSES per 5.5.10.1 ¹
Quarterfinal 1 (1 vs.8)	Quarterfinal 5 (1 vs.8)	Quarterfinal Tiebreaker 1 ²	Semifinal 1	Final 1
Quarterfinal 2 (4 vs.5)	Quarterfinal 6 (4 vs.5)	Quarterfinal Tiebreaker 2 ²	Semifinal 2	FIELD TIMEOUT
Quarterfinal 3 (2 vs.7)	Quarterfinal 7 (2 vs.7)	Quarterfinal Tiebreaker 3 ²	Semifinal 3	Final 2
Quarterfinal 4 (3 vs.6)	Quarterfinal 8 (3 vs.6)	Quarterfinal Tiebreaker 4 ²	Semifinal 4	FIELD TIMEOUT
FIELD TIMEOUT ²	FIELD TIMEOUT ²	FIELD TIMEOUT ²	Semifinal Tiebreaker 1 ²	Final Tiebreaker ²
		Any Replays due to ties ²	Semifinal Tiebreaker 2 ²	FIELD TIMEOUT ²
			FIELD TIMEOUT ²	Any Replays due to ties ²
			Any Replays due to ties ²	

¹ Specific group determined by FMS

² if required

5.4.4 Playoff Scoring

In the Playoff MATCHES, Teams do not earn Ranking Points; they earn a Win, Loss or Tie. Within each series of the Playoff MATCH bracket, the first ALLIANCE to win two (2) MATCHES will advance.

In the case where the MATCH score of each ALLIANCE is equal, the tie is broken using the following criteria:

Table 5-3: Playoff MATCH Tiebreakers

Order Sort	Criteria
1 st	Fewest number of FOUL points awarded (i.e. the ALLIANCE that played the cleaner MATCH)
2 nd	Cumulative sum of BREACH and CAPTURE points
3 rd	Cumulative sum of scored AUTO points
4 th	Cumulative sum of scored SCALE and CHALLENGE points
5 th	Cumulative sum of scored TOWER GOAL points (High and Low goals from AUTO and TELEOP)
6 th	Cumulative sum of CROSSED UNDAMAGED DEFENSE points (AUTO and TELEOP)
7 th	Replay the MATCH

5.5 Tournament Rules

5.5.1 Safety, Security, and Conduct Rules

- T1** Safety is paramount at all times during the Tournament. Event staff have the final decision authority for all safety-related issues within the venue. All event attendees must wear safety glasses and closed-toed shoes while in the ARENA.
- T2** Wireless ROBOT control is only permitted on the FIELD or Practice Field. ROBOTS must be operated by tether when outside the FIELD or Practice Field.
- T3** If operating wirelessly on the Practice Field, ROBOTS must use the provided Practice Field radio for communication.
- T4** Teams may not set up their own 802.11a/b/g/n/ac (2.4GHz or 5GHz) wireless communication (e.g. access points or ad-hoc networks) in the venue.

A wireless hot spot created by a cellular device is considered an access point.

- T5** No Team or Team member shall interfere or attempt to interfere with any other Team's or FIRST's wireless communication. Except as expressly allowed for purposes of communicating with the Team's own ROBOT on the FIELD or a Practice Field, no Team or Team member shall connect or attempt to connect to any other Team's or FIRST's wireless network.

Violation: Behavior will be discussed with Team or individual. Violations of this rule are likely to escalate rapidly to YELLOW or RED CARDS, and may lead to dismissal from the event (i.e. the threshold for egregious or repeated violations is relatively low.) Legal action may also be pursued based on applicable law.

Teams are encouraged to report suspected wireless security vulnerabilities to the FIRST Technical Advisor (FTA) if at the event or to FIRST via the [Wireless Security Feedback Form](#)

- T6** All Teams must be civil towards their own Team members, other Teams, competition personnel, FIELD staff, and event attendees while at an FIRST Robotics Competition event.

Violation: Behavior will be discussed with Team or individual. Violations of this rule are likely to escalate to YELLOW or RED CARDS rapidly (i.e. the threshold for egregious or repeated violations is relatively low.)

Examples of incivility include, but are not limited to, use of offensive language or bullying behavior.

- T7** A Team may not encourage an ALLIANCE, of which it is not a member, to play beneath its ability. NOTE: This rule is not intended to prevent an ALLIANCE from planning and/or executing its own strategy in a specific MATCH in which all the ALLIANCE members are participants.

Violation: Behavior will be discussed with Team or individual. Violations of this rule are likely to escalate rapidly to YELLOW or RED CARDS, and may lead to dismissal from the event (i.e. the threshold for egregious or repeated violations is relatively low.)

Example #1: A MATCH is being played by Teams A, B, and C, in which Team C is encouraged by Team D to not SCALE or CHALLENGE the TOWER resulting in Teams A, B, and C not earning a Ranking Point for that achievement. Team D's motivation for this behavior is to prevent Team A from rising in the Tournament rankings and negatively affecting Team D's ranking.

Example #2: A MATCH is being played by Teams A, B, and C, in which Team A is assigned to participate as a SURROGATE. Team D encourages Team A to not participate in the MATCH so that Team D gains ranking position over Teams B and C.

FIRST considers the action of a Team influencing another Team to throw a MATCH, to deliberately miss Ranking Points, etc. incompatible with FIRST values and not a strategy any team should employ.

- T8** A Team, as the result of encouragement by a Team not on their ALLIANCE, may not play beneath its ability. NOTE: This rule is not intended to prevent an ALLIANCE from planning and/or executing its own strategy in a specific MATCH in which all the ALLIANCE members are participants..

Violation: Behavior will be discussed with Team or individual and may include dismissal from the event. If egregious or repeated, YELLOW or RED CARD.

Example #1: A MATCH is being played by Teams A, B, and C. Team D requests Team C to not SCALE or CHALLENGE the TOWER resulting in Teams A, B, and C not earning a Ranking Point for that achievement. Team C accepts this request from Team D. Team D's motivation for this behavior is to prevent Team A from rising in the Tournament rankings negatively affecting Team D's ranking.

Example #2: A MATCH is being played by Teams A, B, and C, in which Team A is assigned to participate as a SURROGATE. Team A accepts Team D's request to not participate in the MATCH so that Team D gains ranking position over Teams B and C.

FIRST considers the action of a Team influencing another Team to throw a MATCH, to deliberately miss Ranking Points, etc. incompatible with FIRST values and not a strategy any team should employ.

- T9** If brought to the ARENA, the Team STANDARD must be constructed to the [Team Standard Specification](#) and installed such that
- A. its vertical support is in the STANDARD holder in the PLAYER STATION to which the Team is assigned, as indicated on the Team sign and,
 - B. oriented with its horizontal support piece parallel to the CASTLE WALL
- Violation: The MATCH will not start until the situation is corrected or the Team STANDARD is removed from the ARENA.*
- T10** During a MATCH, the Team STANDARD may not be touched by any member of the ALLIANCE
- Violation: FOUL, an exception is given for a Team STANDARD which is damaged and/or dangling in front of a DRIVE TEAM*
- T11** The OPERATOR CONSOLE must be used in the PLAYER STATION to which the Team is assigned, as indicated on the Team sign.
- Violation: The MATCH will not start until the situation is corrected. If during a MATCH, YELLOW CARD.*

One intent of **T11** is to prevent unsafe situations where long tethers to OPERATOR CONSOLE devices increase tripping hazards as the operator moves about the CASTLE. In the interest of avoiding nuisance penalties associated with an operator stepping outside of a prescribed area, we prefer to offer a general guideline as to what it means to use the OPERATOR CONSOLE in the CASTLE. Provided the operator is within close proximity of their PLAYER STATION, there will be no repercussions. However, if an operator is located more than approximately $\frac{1}{2}$ PLAYER STATION width away from their own PLAYER STATION, that would be considered a violation of **T11**.

5.5.2 Eligibility and Inspection

This section describes the rules governing MATCH participation. A Team has participated in a MATCH if any member of their DRIVE TEAM is in the CASTLE or the SPY BOX, with or without the ROBOT on the FIELD, at the start of the MATCH.

At each event, the Lead ROBOT Inspector (LRI) has final authority on the legality of any COMPONENT, MECHANISM, or ROBOT. Inspectors may re-Inspect ROBOTS to ensure compliance with the rules.

ROBOTS are permitted to participate in scheduled Practice MATCHES prior to passing Inspection. However, the *FIRST* Technical Advisor (FTA), LRI or Head REFEREE may determine at any time that the ROBOT is unsafe, per [Section 3 \(3.4.1 Safety Rules\)](#), and may prohibit further participation in Practice MATCHES until the condition is corrected and the ROBOT passes Inspection.

Prior to the start of a MATCH, any ROBOT which is unable or ineligible to participate in that MATCH as determined by the FTA, LRI, or Head REFEREE is declared to be BYPASSED and is DISABLED. A Team who's ROBOT is BYPASSED remains eligible to receive Qualification Ranking Points or Playoff MATCH points provided that its ROBOT has passed Inspection, per [T12](#).

Each registered *FIRST* Robotics Competition team may enter only one (1) ROBOT (or 'Robot', which to a reasonably astute observer, is a Robot built to play *FIRST STRONGHOLD*) into the 2016 *FIRST* Robotics Competition.

“Entering” a ROBOT (or Robot) in to a *FIRST* Robotics Competition means bringing it to the event such that it’s an aid to your Team (e.g. for spare parts, judging material, or for practice). Spare FABRICATED ITEMS may be brought to the event in a bag or part of a WITHHOLDING ALLOWANCE.

This rule does not prohibit teams from bringing in *FIRST* LEGO® League or *FIRST* Tech Challenge robots for the purposes of awards presentations or pit displays.

T12 A Team is only permitted to participate in a Qualification or Playoff MATCH and receive Ranking or MATCH Points respectively if their ROBOT has passed an initial, complete Inspection.

Violation: If prior to the start of the MATCH, the Team is not eligible to participate in the MATCH. If after the start of the MATCH, the entire ALLIANCE receives a RED CARD for that MATCH.

Please take note of this rule. It is important that *FIRST* Robotics Competition Teams ensure their ALLIANCE partners have passed Inspection. Allowing a partner that has not passed Inspection to play puts the ALLIANCE at risk of DISQUALIFICATION. Teams should check with their ALLIANCE partners early, and help them pass Inspection before competing.

T13 Each Team must send at least one (1) member of its DRIVE TEAM to the FIELD and participate in each of the Team’s assigned Qualification and Playoff MATCHES. The Team should inform the Lead Queuer if the Team’s ROBOT is not able to participate.

Violation: RED CARD, with the exception of a Team that has not passed an initial, complete Inspection, per T12.

Figure 5-3: MATCH Eligibility Flowchart

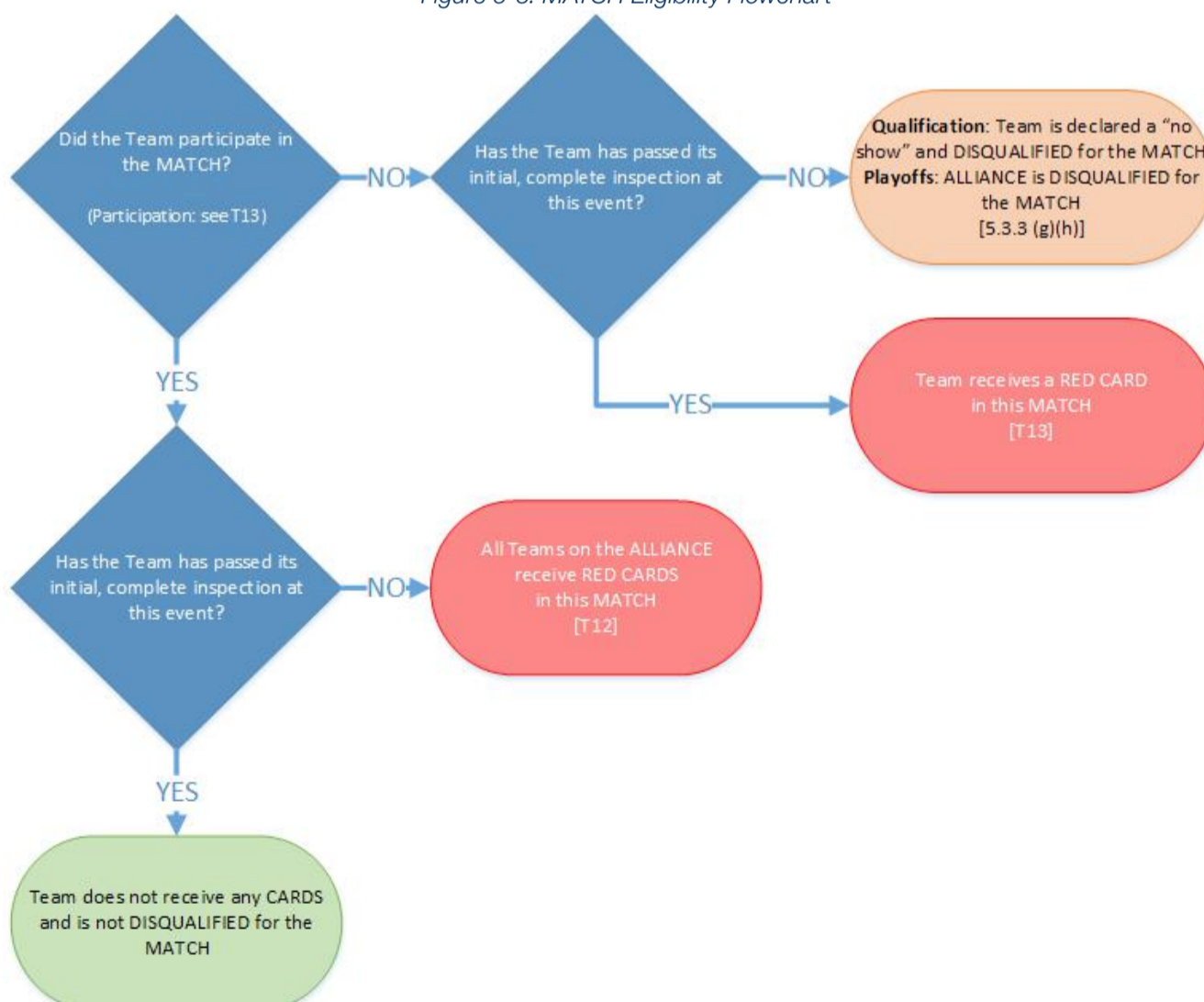

- T14** At the time of Inspection, the ROBOT must be presented with all MECHANISMS (including all COMPONENTS of each MECHANISM), configurations, and decorations that will be used on the ROBOT during the competition event. It is acceptable, however, for a ROBOT to play MATCHES with a subset of the MECHANISMS that were present during Inspection. Only MECHANISMS that were present during the Inspection may be added, removed or reconfigured between MATCHES. If MECHANISMS are changed between MATCHES the reconfigured ROBOT must still meet all Inspection criteria.
- T15** If a ROBOT is modified after it has passed its most recent Inspection, other than modifications listed in A through F, that ROBOT must be re-Inspected before the ROBOT is eligible to participate in a MATCH. If any of the exceptions listed below result in a significant change to the ROBOT'S size, weight, legality, or safety, the ROBOT must be re-Inspected. When in doubt, the Team should ask to be re-Inspected.
- A. Addition, relocation, or removal of fasteners (e.g. cable ties, tape, and rivets)
 - B. Addition, relocation, or removal of labeling or marking
 - C. Revision of ROBOT code
 - D. A replacement of a COTS component with an identical COTS component
 - E. A replacement of a MECHANISM with an identical MECHANISM (size, weight, material)
 - F. Additions, removals, or reconfiguration of ROBOT with a subset of MECHANISMS already Inspected per [T14](#).

Example 1: Team A's ROBOT has passed Inspection, but burns out a motor controller during a MATCH. Team A replaces it with an identical motor controller. Team A does not have to get their ROBOT re-Inspected per exception **T15-D**.

Example 2: Team B would like to add weight to their ROBOT to lower their center of gravity. Team B adds a large amount of fasteners to their ROBOT as ballast. Team B must get their ROBOT re-Inspected because they have significantly changed their weight per **T15**.

Example 3: Team D has decided to move their motor controller to a different location on their ROBOT, and must use a different length wire to make the proper connections. Team D must get their ROBOT re-Inspected because rewiring is not an exception in **T15**.

Example 4: Team E decides to relocate their battery on their ROBOT to change their center of gravity. Team E must be re-Inspected as the relocation of COMPONENTS or MECHANISMS is not an exception **T15**.

Example 5: Team F realizes they can gain necessary functionality by building a new MECHANISM at an event and adding it to their ROBOT. Their ROBOT must be re-Inspected.

If an observation is made that another Team's ROBOT may be in violation of the ROBOT rules, please approach *FIRST* officials to review the matter in question. This is an area where *Gracious Professionalism*[®] is very important.

Note that Inspectors will prioritize teams that have not yet completed initial inspection. While every effort will be made to re-inspect Teams in a timely manner, Teams need to consider that they will need to play with the previously inspected configuration if re-inspection cannot be completed before a MATCH. Teams should work with Inspectors when making changes to minimize the chance of this occurring

- T16** The ROBOT Cost Accounting Worksheet (CAW), listing all items on the ROBOT except those listed in **R10** and their relevant costs per **Section 4 (4.4 Budget Constraints)**, must be presented at the time of Inspection.

Teams are encouraged to use the CAW Template posted on the *FIRST* website. Please note that while CAWs must be shown to Inspectors, Teams are not required to submit their CAWs to the Inspectors.

- T17** During the event, from load-in on the first day to load-out on the final day, Teams may only produce FABRICATED ITEMS in the pit areas or provided machine shops, as defined in the "Administrative Manual," **Section 4 (4.7.4 Team Pits)**, and per **R18** in **Section 4 (4.6 Material Utilization)**.

T18 For the safety of all those involved, Inspections must take place with the ROBOT powered off, pneumatics unpressurized, and springs or other stored energy devices in their lowest potential energy states (e.g. battery removed).

Power and air pressure should only be enabled on the ROBOT during those portions of the Inspection process where it is absolutely required to validate certain system functionality and compliance with specific rules (firmware check, etc.). Inspectors may allow the ROBOT to be powered up beyond the parameters above if both criteria below are met.

- A. The ROBOT design requires power or a charged stored energy device in order to confirm that the ROBOT meets volume requirements, and
- B. The Team has included safety interlocks that mitigate unexpected release of such stored energy.

5.5.3 REFEREE Interaction

The Head REFEREE has the ultimate authority in the ARENA during the event, but may receive input from additional sources, e.g. Game Designers, *FIRST* personnel, FTA, and technical staff. The Head REFEREE rulings are final. No event personnel, including the Head REFEREE, will review video, photos, artistic renderings, etc. of any MATCH, from any source, under any circumstances.

T19 If a DRIVE TEAM needs clarification on a ruling or score, one (1) pre-college student from that DRIVE TEAM should address the Head REFEREE after the ARENA Reset Signal (e.g. TOWER LED strings turn green). A DRIVE TEAM member signals their desire to speak with the Head REFEREE by standing in the corresponding Red or Blue Question Box, which are located on the floor near each end of the scoring table. Depending on timing, the Head REFEREE may postpone any requested discussion until the end of the subsequent MATCH.

As a process improvement, in this year's REFEREE training we instructed them to not record details about FOULS and TECHNICAL FOULS; as a result, we don't expect REFEREES to recall details about what FOULS or TECHNICAL FOULS were made, when they occurred, and against whom.

The goal is to increase consistency across events while enabling and empowering REFEREES to focus on the play on the FIELD (instead of worrying about keeping detailed records during the MATCH). Any reasonable question is fair game in the Question Box, and Head REFEREES will do good faith efforts to provide helpful feedback (e.g. how/why certain FOULS are being called, why a particular ROBOT may be susceptible to certain FOULS based on its design or game play, how specific rules are being called or interpreted), but please know that they will likely not be able to supply specific details.

5.5.4 YELLOW and RED CARDS

In addition to rule violations explicitly listed in [Section 3 \(3.4 Rules\)](#), YELLOW CARDS and RED CARDS are used in *FIRST* Robotics Competition to manage Team and ROBOT behavior that does not align with the mission of *FIRST*.

The Head REFEREE may assign a YELLOW CARD as a warning, or a RED CARD for DISQUALIFICATION in MATCH, as a result of egregious or repeated ROBOT or Team member behavior at the event. A YELLOW or RED CARD is indicated by the Head REFEREE standing in front of the Team's PLAYER STATION and holding a YELLOW and/or RED CARD in the air.

Examples of egregious behavior include, but are not limited to, severe and/or repeated violations of a rule and/or other inappropriate behavior such as repeated use of offensive language or other uncivil conduct.

YELLOW CARDS are additive, meaning that a second YELLOW CARD is automatically converted to a RED CARD. A Team is issued a RED CARD for any subsequent incident in which they receive an additional YELLOW CARD, including earning a second YELLOW card during a single MATCH. A second YELLOW CARD is indicated by the Head REFEREE standing in front of the Team's PLAYER STATION and holding a YELLOW CARD and RED CARD in the air simultaneously after the completion of the MATCH. A Team that has received either a YELLOW CARD or a RED CARD carries a YELLOW CARD into subsequent MATCHES, except as noted below. A RED CARD results in DISQUALIFICATION.

Once a Team receives a YELLOW or RED CARD, its Team number will be presented with a yellow background on the audience screen at the beginning of all subsequent MATCHES as a reminder to the Team, the REFEREES, and the audience that they carry a YELLOW CARD.

Figure 5-4: Audience Screen Graphic Showing YELLOW and RED CARD Indicators

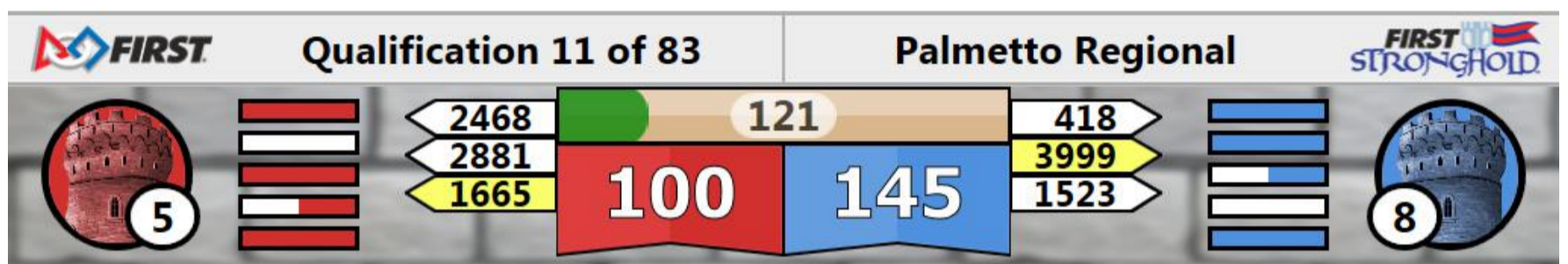

All YELLOW CARDS are cleared at the conclusion of Qualification MATCHES, providing teams a clean slate at the beginning of Playoff MATCHES.

During the Playoff MATCHES, if a Team receives a YELLOW or RED CARD, it results in the the entire ALLIANCE receiving the YELLOW or RED CARD for that MATCH. If two different Teams on the same ALLIANCE are issued YELLOW CARDS, the entire ALLIANCE is issued a RED CARD. A RED CARD results in zero (0) points for that MATCH, and the ALLIANCE loses the MATCH. If both ALLIANCES receive RED CARDS, the ALLIANCE which committed the action earning the RED CARD first chronologically loses the MATCH.

YELLOW and RED CARDS are applied based on the following:

Table 5-4: YELLOW and RED CARD application

Time YELLOW or RED CARD earned	MATCH to which CARD is applied
prior to the start of Qualification MATCHES	Team's first Qualification MATCH
during the Qualification MATCHES	Team's current (or just-completed) MATCH. In the case where the Team participated as a SURROGATE in the current (or just completed) MATCH, the card is applied to the Team's previous MATCH (i.e. the Team's second Qualification MATCH.)
between the end of Qualification MATCHES and the start of Playoff MATCHES	ALLIANCE'S first Playoff MATCH
during the Playoff MATCHES	ALLIANCE'S current (or just-completed) MATCH

5.5.5 MATCH Replays

Over the course of the Tournament, ARENA FAULTS may occur. An ARENA FAULT is an error in ARENA operation that includes, but is not limited to:

- A. broken FIELD elements,
- B. power failure to a portion of the FIELD (tripping the circuit breaker in the PLAYER STATION is not considered a power failure)
- C. improper activation by the FMS
- D. errors by FIELD STEWARDS
- E. a Team STANDARD falling into the FIELD

T20 If, in the judgment of the Head REFEREE, an ARENA FAULT occurs that affects the outcome of the MATCH and any team on the affected ALLIANCE desires a replay, the MATCH will be replayed.

All reasonable effort is made to create the same conditions when replaying a MATCH. This means, for example, that a Team which was BYPASSED during the MATCH which is to be replayed, is BYPASSED for the replay MATCH. The DEFENSES used during the MATCH which is to be replayed are also used for the replay MATCH.

Note that an ARENA FAULT that does not affect MATCH outcome in the judgement of the Head REFEREE does not lead to a MATCH replay. Examples include, but are not limited to:

- A. a piece of FIELD plastic falls into the FIELD in the last 5 seconds of a MATCH, far away from any human or ROBOT activity, and in such a way that it does not affect MATCH outcome
- B. delay in the playing of an ARENA sound
- C. mismatch between the timer on the Audience Screen and the FIELD Timer

5.5.6 TIMEOUT and BACKUP TEAM Rules

A TIMEOUT is a period of up to six (6) minutes between MATCHES which is used to pause Playoff MATCH progression. Each ALLIANCE is allotted one (1) TIMEOUT. If circumstances require an ALLIANCE to play in back-to-back MATCHES during the Playoff MATCHES, the Head REFEREE will issue a FIELD TIMEOUT to allow Teams to prepare for the next MATCH. FIELD TIMEOUTS are the same time duration as TIMEOUTS.

There are no TIMEOUTS in the Practice or Qualification MATCHES.

During a TIMEOUT, the ARENA Timer will display the time remaining in the TIMEOUT. Both ALLIANCES will enjoy the complete six (6) minute window. If an ALLIANCE completes their repairs before the ARENA Timer expires, the ALLIANCE CAPTAIN is encouraged to inform the Head REFEREE that they are ready to play. If both ALLIANCES are ready to play before the TIMEOUT expires, the next MATCH will start.

Teams are expected to have their ROBOTS staged on the FIELD by the end of the TIMEOUT. Teams that cause a significant delay to the start of a MATCH after a TIMEOUT are subject to G8.

Figure 5-5: TIMEOUT Timeline

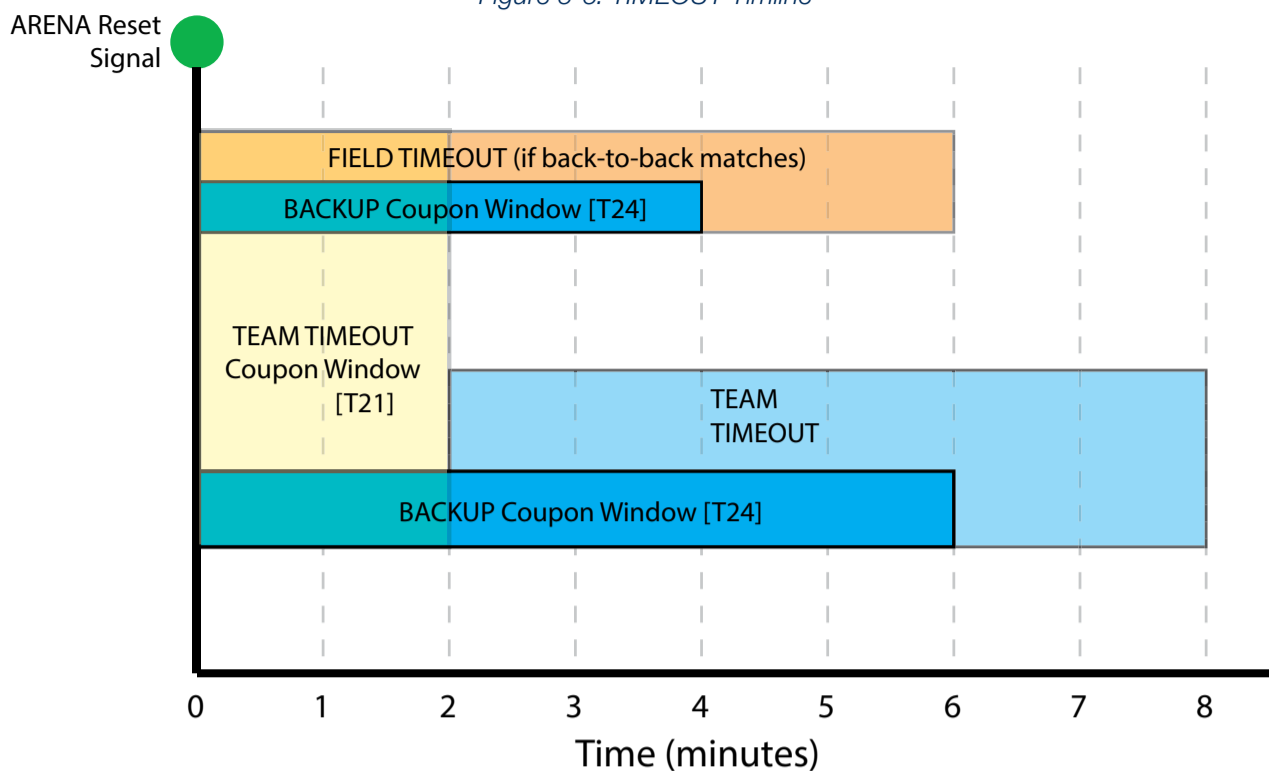

- T21** If an ALLIANCE wishes to call a TIMEOUT, the ALLIANCE CAPTAIN must submit their TIMEOUT coupon to the Head REFEREE within two (2) minutes of the ARENA reset signal preceding their MATCH. If there is no preceding MATCH, the TIMEOUT coupon must be submitted no later than two (2) minutes before the scheduled MATCH time. The TIMEOUT will begin two (2) minutes after the ARENA reset signal (i.e. at the end of the TEAM TIMEOUT Coupon Window depicted in Figure 5-5).
- T22** There are no cascading TIMEOUTS. If an ALLIANCE calls a TIMEOUT during a FIELD TIMEOUT, the FIELD TIMEOUT will expire two (2) minutes after the ARENA reset signal and the ALLIANCE'S TIMEOUT will begin.

If an ALLIANCE wishes to call a TIMEOUT during a FIELD TIMEOUT, it must still do so within two (2) minutes of the ARENA reset signal preceding their MATCH, per Rule T21.

- T23** TIMEOUTS are not transferrable between ALLIANCES.

While TIMEOUTS are not transferrable between ALLIANCES, meaning an ALLIANCE cannot hand their designated TIMEOUT coupon to another ALLIANCE to use, an ALLIANCE may use their own coupon for any purpose they wish.

- T24** If during a TIMEOUT an ALLIANCE CAPTAIN determines that they need to call up a BACKUP TEAM, they must submit their BACKUP TEAM coupon to the Head REFEREE while there are still at least two (2) minutes remaining on the ARENA Timer. After that point, they will not be allowed to utilize the BACKUP TEAM.

Alternatively, an ALLIANCE CAPTAIN may choose to call up a BACKUP TEAM without using their TIMEOUT by informing the Head REFEREE directly within two (2) minutes of the Head REFEREE issuing the ARENA reset signal preceding their MATCH. If there is no preceding MATCH, the BACKUP TEAM coupon must be submitted no later than two (2) minutes before the scheduled MATCH time.

In the case where the ALLIANCE CAPTAIN'S ROBOT is replaced by a BACKUP TEAM, the ALLIANCE CAPTAIN is allowed in the CASTLE as a thirteenth ALLIANCE member so they can serve in an advisory role to their ALLIANCE.

The Head REFEREE will not accept the BACKUP TEAM coupon unless it lists the number of the Team whose ROBOT is being replaced, and is initialed by the ALLIANCE CAPTAIN. Once a BACKUP TEAM coupon is submitted and accepted by the Head REFEREE, the BACKUP TEAM coupon may not be withdrawn by the ALLIANCE.

- T25** An ALLIANCE may request neither a TIMEOUT nor a BACKUP TEAM after a Playoff MATCH is stopped by the Head REFEREE (e.g. due to an ARENA FAULT or a safety issue). The sole exception is if the replay is due to an ARENA FAULT that rendered a ROBOT inoperable.

If a Playoff MATCH is replayed per **T25** the Head REFEREE has the option of calling a FIELD TIMEOUT.

5.5.7 Pit Crews

During the Playoff MATCHES, extra Team members may be needed to maintain the ROBOT between MATCHES because of the distance between the FIELD and the pit area. Each Team is permitted to have three (3) additional “pit crew” members who can also help with needed ROBOT repairs/maintenance

- T26** Pit Crew members cannot be in the CASTLE during a MATCH.

Violation: MATCH will not start until the situation is corrected. Those not displaying identification must leave the ARENA

5.5.8 Measurement

The ARENA will be open for at least 30 minutes prior to the start of Qualification MATCHES, during which time Teams may survey and/or measure the FIELD, and bring ROBOTS on the FIELD to perform sensor calibration. During this time ROBOTS can be enabled, but can not move, nor can they interact (e.g. shoot, push, pickup, etc.) with BOULDERS or DEFENSES. The specific time that the FIELD is open will be communicated to Teams at the event. Teams may bring specific questions or comments to the FTA.

5.5.9 Special Equipment Rules

- T26-1** The only equipment, provided it does not block visibility for FIELD STEWARDS or audience members or jam or interfere with the remote sensing capabilities of another Team, including vision systems, acoustic range finders, sonars, infrared proximity detectors, etc. (e.g. including imagery that, to a reasonably astute observer, mimics the Vision Guides), that may be brought in to the CASTLE are as follows:

- A. the OPERATOR CONSOLE,
- B. non-powered signaling devices,
- C. reasonable decorative items,
- D. TEAM STANDARDS and devices, if needed, to assist placement in the Standard Holder,
- E. special clothing and/or equipment required due to a disability
- F. devices used solely for the purpose of planning or tracking strategy provided they meet all of the following conditions:
 - i. do not connect or attach to the OPERATOR CONSOLE
 - ii. do not connect or attach to the FIELD or ARENA
 - iii. do not connect or attach to another ALLIANCE member
 - iv. do not communicate with anything or anyone outside of the ARENA.

- v. do not include any form of enabled wireless electronic communication (e.g. radios, walkie-talkies, cell phones, Bluetooth communications, Wi-Fi, etc.)
- vi. do not in any way affect the outcome of a MATCH, other than by allowing PLAYERS to plan or track strategy for the purposes of communication of that strategy to other ALLIANCE members.

G. non-powered Personal Protective Equipment (examples include, but aren't limited to, gloves, eye protection, and hearing protection)

Items B, C, E, F and G also apply to the DRIVE TEAM Member in the SPY BOX.

Violation: MATCH will not start until situation remedied.

5.5.10 Selecting Defenses

The specific DEFENSES used during each MATCH are selected by a combination of the audience and the ALLIANCES. One (1) DEFENSE from each of the four (4) DEFENSE groups, A, B, C, and D are on the FIELD each Qualification and Playoff MATCH.

During the Practice MATCHES, ALLIANCES select DEFENSES for positions 2 through 5 to fortify their opponent's OUTER WORKS and may select any four (4) DEFENSES from the four (4) groups. For example, each of the two (2) DEFENSES from groups A and B. This provides each ALLIANCE with a predictable set of DEFENSES on which to practice. During Qualification MATCHES, ALLIANCES select DEFENSES to fortify their own OUTER WORKS (the OUTER WORKS closest to their TOWER).

5.5.10.1 AUDIENCE SELECTION OF DEFENSES

Prior to each round of Qualification and Playoff MATCHES, the audience selects one of the DEFENSES used by both ALLIANCES on the FIELD. The Audience selected DEFENSE is located in the OUTER WORKS position 3 for both ALLIANCES. The selection process is managed by the Herald (MC) and overseen by the Head REFEREE. The DEFENSE which receives the loudest response, as judged by the Head REFEREE, will be the chosen DEFENSE for the upcoming round of MATCHES.

The FMS determines the order in which the DEFENSE groups are selected by the audience. The group selected by the audience during each round of MATCHES is printed on the Qualification MATCH Schedule as shown in [Figure 5-1](#). While the first group is determined randomly, the groups rotate alphabetically for each subsequent selection. For example, if group B is used for the MATCHES in Round 1, the order will be group C in Round 2, group D in Round 3, group A in Round 4, etc. This order continues into the Playoff MATCHES. For example, if group B is the last group used during the Qualification MATCHES, group C will be used for the first round of the Playoff Quarterfinals, group D is used for the second round, etc.

5.5.10.2 TEAM SELECTION OF DEFENSES

Selection of DEFENSES by each ALLIANCE shall follow the processes outlined below:

During Qualification MATCHES:

- Step 1 – Once in the Queue and no later than the end of the MATCH two (2) MATCHES prior to their scheduled MATCH (i.e. "Queue #2"): Each ALLIANCE selects the DEFENSES and DEFENSE locations on the FIELD and communicates the selections to the Defense Coordinator (DC). The DC's location is fixed throughout the event, but varies event-to-event depending on available space in each venue.

- Step 2 – Queued and no later than the start of the MATCH one (1) MATCH prior to their scheduled MATCH (i.e. “Queue #1”): ASAP & concurrently, the DC makes available to each ALLIANCE a map revealing the DEFENSES and locations.
- Step 3 – ALLIANCES move from the queue to the FIELD

An ALLIANCE of Teams A, B, and C (ALLIANCE ‘ABC’) is scheduled to complete in MATCH 10. The Teams arrive in the Queue during Match 7. Match 7 ends, and the Teams for Match 8 proceed on to the FIELD. ALLIANCE ‘ABC’ is now in position Q2 and has until the end of Match 8 to give their DEFENSE selections to the DC. Match 8 ends and the Teams for Match 9 move to the FIELD, ALLIANCE ‘ABC’ is now in position Q1 and is given the receipt from the DC revealing the DEFENSES selected by the ALLIANCE they’ll be playing against in MATCH 10. They now have the time during MATCH 9 to plan their strategy. At the conclusion of MATCH 9, ALLIANCE ABC proceeds to the FIELD to participate in MATCH 10.

The DEFENSE selection process outlined for the Qualification MATCHES will also be employed during Practice MATCHES. Strict adherence to this process during all, or only a portion of, the Practice MATCHES will be left to the discretion of the FTA based on the number of available FIELD STEWARDS.

During Playoff MATCHES:

- Step 1 – Once in the Queue and no later than the end of the MATCH or FIELD TIMEOUT which immediately precedes their scheduled MATCH (i.e. “Queue #1”): Each ALLIANCE selects the DEFENSES and their locations on the FIELD and communicates the selections to the Defense Coordinator (DC).
- Step 2 – Strategize: ASAP & concurrently, DC gives each ALLIANCE a map revealing the DEFENSES and locations. The teams then have two (2) minutes to plan their strategy and move their ROBOTS from the queue to the FIELD.

The DEFENSE selection process is modified during the Playoffs due to several cases where ALLIANCES may play in back-to-back MATCHES. In these circumstances there isn’t a state where an ALLIANCE is in Queue #2., so a similar amount of reasonable time is provided for ALLIANCES to plan their strategy and select DEFENSES.

Figure 5-6: DEFENSE Selection Timeline for Qualification and Quarterfinal Playoff MATCHES (see Qualification MATCH Blue Box Example)

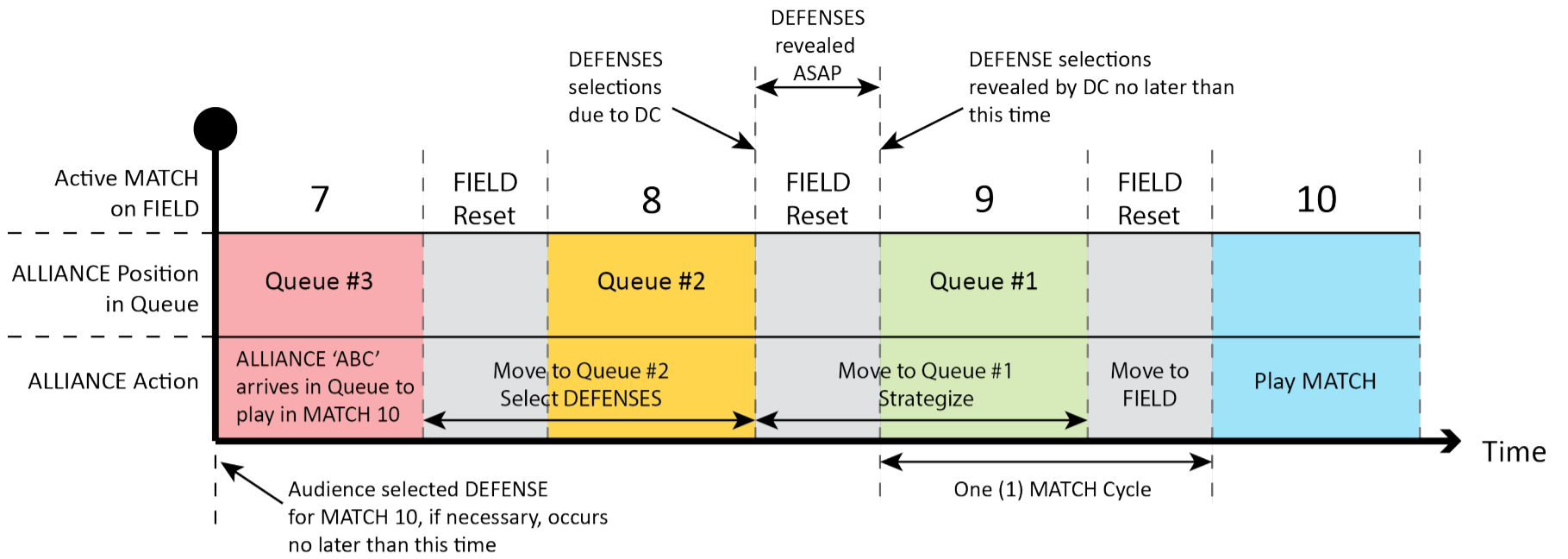

Figure 5-7: Abbreviated DEFENSE Selection Timeframe for Semifinal and Final Playoff MATCHES

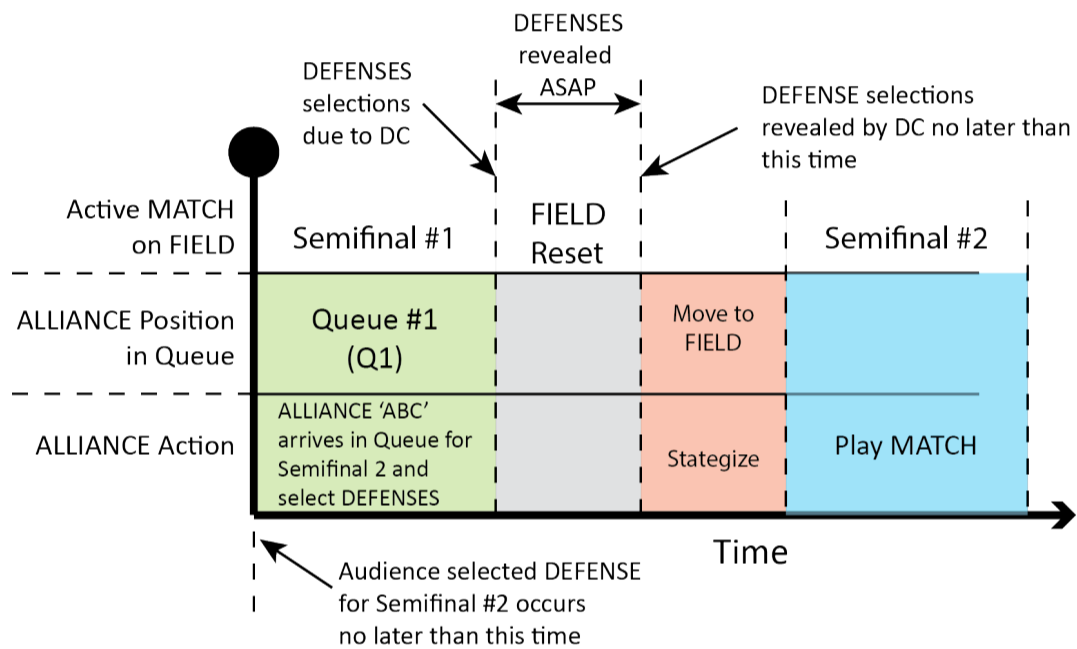

Figure 5-8: DEFENSE Selection Timeline for back-to-back MATCHES

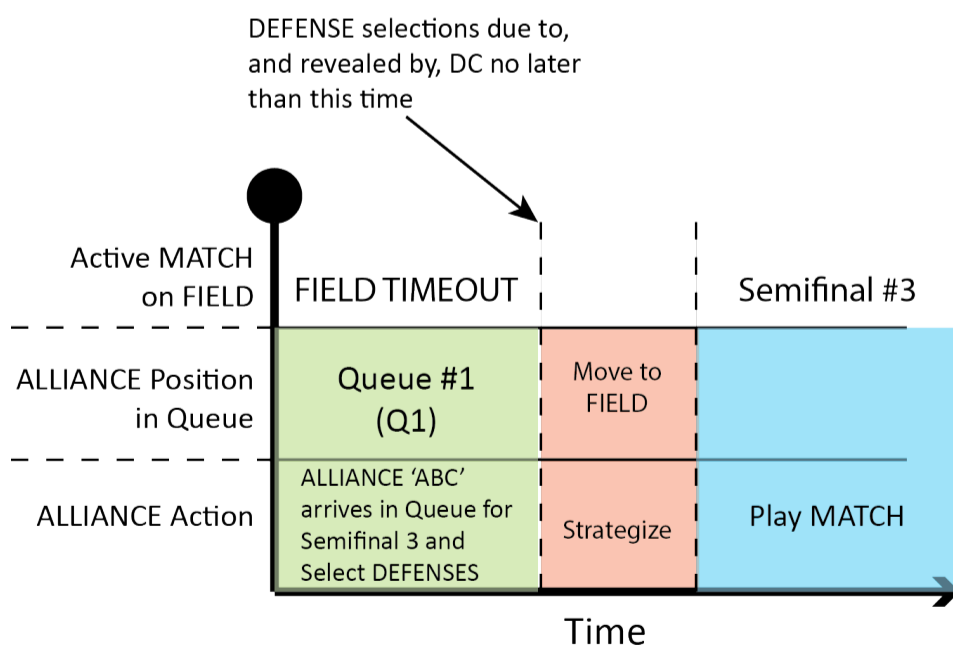

Figure 5-9: DEFENSE Selection Timeline Prior to Opening Ceremonies or After Breaks

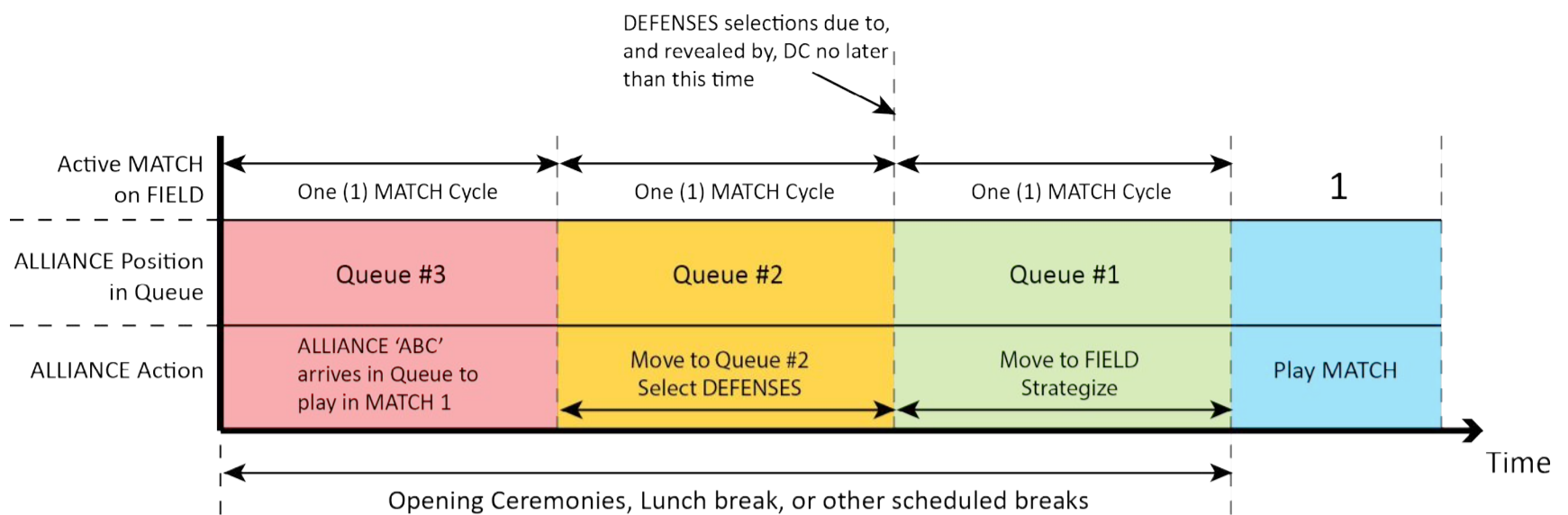

Figure 5-9 outlines the DEFENSE selection process employed prior to Opening Ceremonies, or after scheduled breaks, such as lunch. The process is for all intents and purposes the same as depicted in Figure 5-6. The DC will enforce time limits similar to what would be expected during normal MATCH play. The event staff are given some flexibility to define the exact amount of time provided for the selection of DEFENSES and strategizing during these periods. Teams are encouraged to arrive in the queue early enough to allow sufficient time for DEFENSE selection and to strategize with their ALLIANCE partners.

For example, a Qualification schedule is set to start at 8:30AM that has a cycle time of 7 minutes, i.e. MATCHES start every 7 minutes. Prior to the start of these MATCHES there is a 30 minute Opening Ceremony starting at 8:00AM. The Event Staff elects to enforce 7 minute cycle time windows for the selection of DEFENSES and strategizing prior to the start of MATCH #1 which runs concurrent with the Opening Ceremony. The Teams scheduled to play in MATCH #1 must have their DEFENSE selections to the DC no later than 8:23AM.

The following rules apply to the Team Selection of DEFENSES.

- T27** Only a single ALLIANCE representative, from a DRIVE TEAM, may interact with the DC at a time.
- T28** If there is a disagreement amongst the Teams on an ALLIANCE regarding the specific DEFENSES or their locations on the FIELD, the ALLIANCE CAPTAIN or Team assigned to PLAYER STATION #2 has the final decision authority. If the ALLIANCE CAPTAIN or the Team assigned to PLAYER STATION #2 is not eligible to participate in the MATCH the decision authority falls to the Team assigned to PLAYER STATION #1. If none of these Teams is eligible to participate in the MATCH, the decision authority is with the Team in PLAYER STATION #3.
- T29** During Qualification and Quarterfinal MATCHES, ALLIANCES must inform the DC of their DEFENSE selections prior to moving to "Queue #1"
- T30** During Semifinal and Final MATCHES, ALLIANCES must inform the DC of their DEFENSE selections prior to the conclusion of the MATCH or FIELD TIMEOUT which immediately precedes their scheduled MATCH.
- T31** If an ALLIANCE does not communicate its DEFENSE selection to the DC within the required time period, the DEFENSES are randomly selected by the FMS.
- T32** Once the DEFENSE selections are communicated to the DC they cannot be changed.

5.6 Championship Additions and Exceptions

At the 2016 *FIRST* Championship, Teams are split into eight (8) Subdivisions. Each Subdivision plays a standard Tournament as described in [Section 5.3 Qualification MATCHES](#), [Section 5.4 Playoff MATCHES](#), [Section 5.5 Tournament Rules](#), with the exception of [Section 5.4.1 ALLIANCE Selection Process](#) and [Section 5.4.2 BACKUP TEAMS](#), to produce the Subdivision Champions. Those eight (8) Subdivision Champions proceed to the Championship Playoffs, on the Einstein FIELDS, to determine the 2016 *FIRST* Robotics Competition Champions.

There is no provision for BACKUP TEAMS at the Championship.

5.6.1 Four ROBOT ALLIANCES

Before each Subdivision Playoff Tournament, ALLIANCES will be selected per the process as described in [Section 5.4.1 ALLIANCE Selection Process](#), however the process will continue with a 3rd round of selection as follows.

Round 3: The same method is used for each ALLIANCE CAPTAIN'S third choice except the selection order is reversed again, with ALLIANCE One picking first and ALLIANCE Eight picking last. This process results in eight (8) ALLIANCES of four (4) Teams each.

ALLIANCES may start with any three (3) of the four (4) ROBOTS on their ALLIANCE during Subdivision Playoff MATCHES and during the Championship Playoffs. The list of three (3) Teams participating in the MATCH and their selected PLAYER STATIONS is called the LINEUP. One representative from the Team not on the LINEUP is allowed in the CASTLE as a thirteenth ALLIANCE member.

T33 The ALLIANCE CAPTAIN must report the LINEUP to the Head REFEREE, or their designee, in writing prior to end of the preceding MATCH (e.g. the LINEUPS for Quarterfinal 2 must be submitted before the end of Quarterfinal 1). If there is no preceding MATCH, the LINEUP is due no later than two (2) minutes before the scheduled MATCH time.

Violation: The LINEUP is the same as the ALLIANCE'S previous MATCH. If any of these three (3) ROBOTS are unable to play, the ALLIANCE must play the MATCH with only two (2) (or even one (1)) ROBOTS.

If an ALLIANCE fails to submit a LINEUP per the process defined in **T33** and the MATCH is their first of the Subdivision Playoffs or the Championship Playoffs, the LINEUP will be the ALLIANCE Lead, first ALLIANCE selection, and second ALLIANCE selection. If any of these three (3) ROBOTS are unable to play, the ALLIANCE must play the MATCH with only two (2) (or even one (1)) ROBOTS.

The LINEUP will be kept confidential until the FIELD is set for the MATCH, at which point each ALLIANCE'S LINEUP will appear on the Team Signs.

T34 Once the LINEUP has been declared, it cannot be changed unless there is a TIMEOUT. If there is a TIMEOUT, the ALLIANCE CAPTAIN may submit a different LINEUP, but must do so while there are still more than two (2) minutes remaining in the TIMEOUT.

Example: Four (4) Teams, A, B, C and D, form an ALLIANCE going into the Playoff MATCHES on their Subdivision FIELD. During one of the Playoff MATCHES, Team C's ROBOT becomes inoperable. The ALLIANCE decides to bring in Team D to replace Team C. Team C repairs their ROBOT and may play in any subsequent Playoff MATCHES replacing Teams A, B, or D. All four (4) ALLIANCE members are also eligible to play MATCHES during the Championship Playoffs should the ALLIANCE win the Subdivision Tournament.

T35 If a MATCH must be replayed due to an ARENA FAULT, the LINEUP for the replayed MATCH is the same as the original MATCH. The sole exception is if the ARENA FAULT rendered a ROBOT inoperable, in which case the LINEUP can be changed.

5.6.2 Championship Pit Crews

FIRST will distribute badges to the ALLIANCE CAPTAINS during the ALLIANCE CAPTAIN meeting, which takes place on the Subdivision FIELDS. These badges will provide the necessary access to the ARENA for pit crew members.

T36 Only Team members wearing proper badges are allowed on the ARENA floor during Subdivision and Championship Playoff MATCHES.

Violation: MATCH will not start until the situation is corrected. Those not displaying identification must leave the ARENA.

Teams should assume they may be chosen for an ALLIANCE and think about the logistics of badge distribution and set a plan prior to the ALLIANCE selection process. It is each ALLIANCE CAPTAIN'S responsibility to get the Team's badges to the pit crew members.

5.6.3 FIRST Robotics Competition Championship MATCH Bracket

The figure below details the order in which MATCHES are played during the Championship Playoffs.

Figure 5-10: Championship Playoff MATCH Bracket

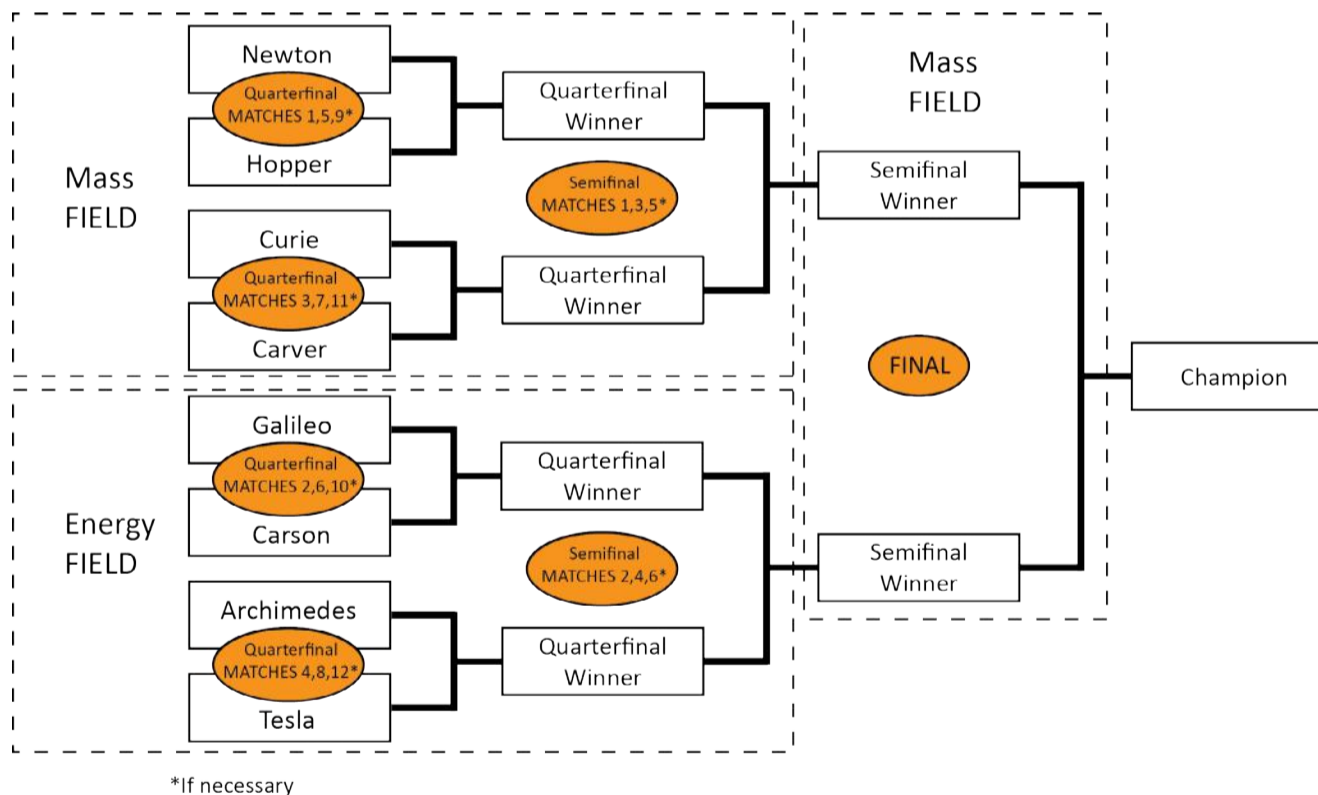

In order to allow time between MATCHES for all ALLIANCES and the selection of DEFENSES, the order of play is as follows:

Table 5-5: FIRST Championship Playoff Order and Audience DEFENSE Selection Timing

Quarterfinal Round 1	Quarterfinal Round 2	Quarterfinal Round 3	Semifinals	Finals
Audience selects DEFENSES per 5.5.10.1 ¹	Audience selects DEFENSES per 5.5.10.1 ¹	Same Group selection as Qual Round 2	Audience selects DEFENSES per 5.5.10.1 ¹	Audience selects DEFENSES per 5.5.10.1 ¹
Quarterfinal 1 (Newton vs.Hopper)	Quarterfinal 5 (Newton vs.Hopper)	Newton vs. Hopper Tiebreaker ²	Semifinal 1	Final 1
Quarterfinal 2 (Curie vs.Carver)	Quarterfinal 6 (Curie vs.Carver)	Curie vs.Carver Tiebreaker ²	Semifinal 2	FIELD TIMEOUT
Quarterfinal 3 (Galileo vs.Carson)	Quarterfinal 7 (Galileo vs.Carson)	Galileo vs.Carson Tiebreaker ²	Semifinal 3	Final 2
Quarterfinal 4 (Archimedes vs.Tesla)	Quarterfinal 8 (Archimedes vs.Tesla)	Archimedes vs.Tesla Tiebreaker ²	Semifinal 4	FIELD TIMEOUT
	FIELD TIMEOUT ²	FIELD TIMEOUT ²	Semifinal Tiebreaker 1 ²	Final Tiebreaker ²
		Any Replays due to ties ²	Semifinal Tiebreaker 2 ²	FIELD TIMEOUT ²
			FIELD TIMEOUT ²	Any Replays due to ties ²
			Any Replays due to ties ²	

¹ specific group determined by FMS

² if required

5.6.4 TIMEOUTS

For the Einstein Tournament, each ALLIANCE will be issued one TIMEOUT coupon for use as described in *Section 5.5.6 TIMEOUT and BACKUP TEAM Rules*.

- T37** If an Einstein ALLIANCE wishes to call a TIMEOUT, the ALLIANCE CAPTAIN must submit their TIMEOUT coupon to the Head REFEREE (or their designee) on the FIELD that will host their next MATCH within two (2) minutes of the ARENA reset signal from the previous MATCH and associated FIELD. If there is no preceding MATCH, the TIMEOUT coupon must be submitted no later than two (2) minutes before the scheduled MATCH time. The TIMEOUT will begin two (2) minutes after the ARENA reset signal (i.e. at the end of the TEAM TIMEOUT Coupon Window depicted in *Figure 5-11*).

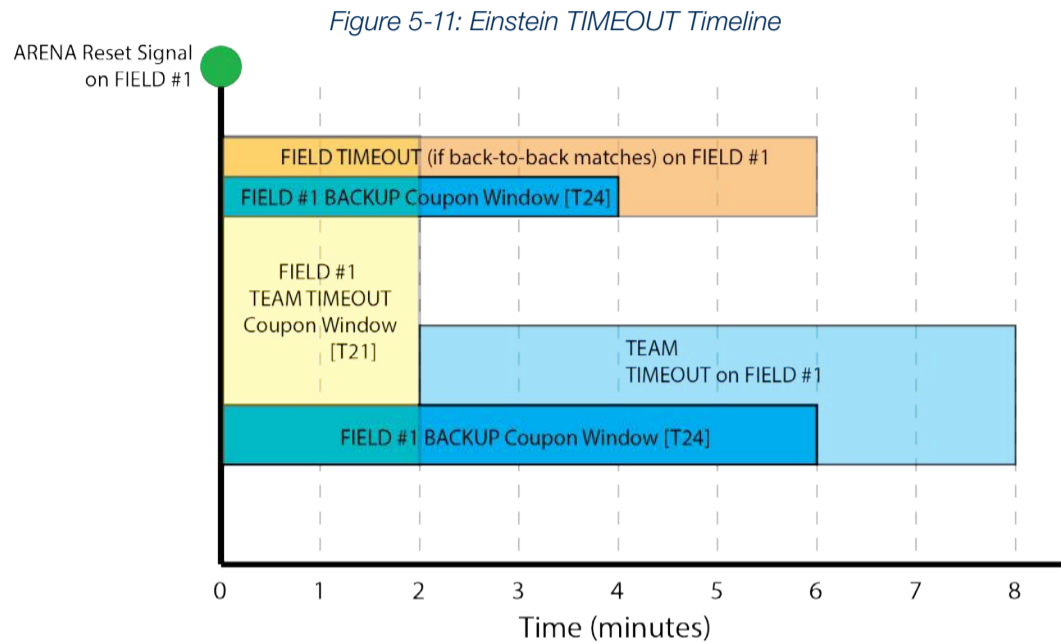

FIRST[®], the *FIRST*[®] logo, *FIRST*[®] Robotics Competition, *Coopertition*[®], *Gracious Professionalism*[®] are registered trademarks, and *Sport for the Mind*[™] and *FIRST STRONGHOLD*SM are common law trademarks, of the United States Foundation for Inspiration and Recognition of Science and Technology (*FIRST*[®]). ©2016 *FIRST*[®]. All rights reserved.

6 GLOSSARY

Term	Definition
ALLIANCE	a set of up to four (4) <i>FIRST</i> Robotics Competition Teams who play <i>FIRST STRONGHOLD</i> together
ALLIANCE CAPTAIN	a designated student representative from an ALLIANCE in a Playoff MATCH displaying the ALLIANCE CAPTAIN identifier (e.g. hat or armband)
ARENA	all elements of the game infrastructure that are required to play <i>FIRST STRONGHOLD</i> SM : the FIELD, the CASTLES, the scoring elements, and all equipment needed for FIELD control, ROBOT control, and scorekeeping
ARENA FAULT	an error in ARENA operation that includes, but aren't limited to those listed in Section 5 (5.5.5 MATCH Replays)
AUTO	the first fifteen (15) seconds of a MATCH in which ROBOTS operate without any DRIVE TEAM control or input
AUTO LINE	a line of green gaffers tape used by Teams to demarcate the field for the AUTO period as per Section 2 (2.1 Zones & Markings)
BACKUP TEAM	a Team used to replace an inoperable ROBOT on an ALLIANCE during Playoff MATCHES per Section 5 (5.5.6 TIMEOUT and BACKUP TEAM Rules)
BATTER	a series of ramps and dividers that compose the base of the TOWER as per Section 2 (2.2.3.1 CASTLE WALL)
BERM	a steel barrier that defines the border of the SECRET PASSAGE as per Section 2 (2.2.2.2 SECRET PASSAGE)
BOULDER	a 10 in. diameter, gray, Gopher SoftiBall™ coated foam ball used by ALLIANCES to score points in <i>FIRST STRONGHOLD</i>
BRATTICE	the hole in the plastic portion of the HUMAN PLAYER STATION used by an ALLIANCE to introduce BOULDERS to the FIELD as per Section 2 (2.2.3.1 CASTLE WALL)
BREACHED	the state of an OUTER WORKS once four (4) out of its five (5) DEFENSES have been DAMAGED
BUMPER	a protective assembly designed to attach to the exterior of the ROBOT and constructed as specified in Section 4 (4.7 BUMPER Rules)
BUMPER ZONE	the volume contained between two virtual horizontal planes, 4 in. above the floor and 12 in. above the floor
BYPASSED	a state in which a ROBOT has been commanded by the Driver Station to deactivate all outputs
CAPTURED	the state of a TOWER if, at the end of the MATCH, it is WEAKENED, and it is surrounded such that each of the three (3) opponent ROBOTS has SCALED or CHALLENGED a unique face of the TOWER
CASTLE	an area located at each end of the FIELD and bounded by and including the edges of the carpet, the CASTLE WALL, and white gaffers tape
CASTLE WALL	the barrier between ROBOTS and DRIVE TEAMS (with the exception of a SPY in the SPY Box) that consists of three (3) PLAYER STATIONS, a HUMAN PLAYER STATION, and a TOWER
CHALLENGE	an act performed by a ROBOT, such that at the conclusion of the MATCH, the ROBOT is fully supported by the TOWER, but hasn't met the criteria for SCALING the TOWER

Term	Definition
COACH	a student or adult Mentor identified as the person wearing the designated “COACH” pin or button during a MATCH
COMPONENT	any part in its most basic configuration, which cannot be disassembled without damaging or destroying the part or altering its fundamental function
CORRAL	the collection area for scored BOULDERS located at the rear base of the TOWER as described in Section 2 (2.2.3.1 CASTLE WALL)
COTS	a “Commercial, Off-The-Shelf” COMPONENT or MECHANISM, in its unaltered, unmodified state. A COTS item must be a standard (i.e. not custom order) part commonly available from the VENDOR, available from a non-Team source, and available to all Teams for purchase. Items that are no longer commercially available but are functionally equivalent to the original condition as delivered from the VENDOR are considered COTS and may be used
COURTYARD	an infinitely tall volume bordered by, but excluding, the CASTLE WALL, the GUARDRAIL, the SECRET PASSAGE and the OUTER WORKS
CROSS	an act performed by a ROBOT, such that it starts free of contact with an opponent DEFENSE and completely in the NEUTRAL ZONE, traverses the DEFENSE such that its BUMPERS go fully between the adjacent SHIELDS/GUARDRAIL, and ends up fully contained by the opponent’s COURTYARD
CUSTOM CIRCUIT	any electrical component of the robot other than motors , pneumatic solenoids, roboRIO, PDP, PCM, VRM, RSL, 120A breaker, motor controllers, relay modules, wireless bridge, or batteries
DAMAGED	the state of a DEFENSE when that DEFENSE’S STRENGTH is zero (0)
DEFENSE	one (1) of five (5) obstacles in the OUTER WORKS and clips in to a PLATFORM
DISABLED	a state in which a ROBOT has been commanded by the Driver Station to deactivate all outputs
DISQUALIFIED	the status of a Team, as determined by the Head REFEREE, in which their Team receives zero (0) Match points in a qualification MATCH or causes their ALLIANCE to receive zero (0) Match points in a Playoff MATCH
DRIVE TEAM	one (1) COACH, two (2) DRIVERS, and one (1) HUMAN PLAYER from the same <i>FIRST</i> Robotics Competition Team who are responsible for ROBOT operation during a particular MATCH
DRIVER	a pre-college student DRIVE TEAM member responsible for operating and controlling the ROBOT during a MATCH
EMBRASURE	a hole at the bottom of the HUMAN PLAYER STATION wall diamond plate which can be used by an ALLIANCE to introduce BOULDERS to the FIELD
FABRICATED ITEMS	any COMPONENT or MECHANISM that has been altered, built, cast, constructed, concocted, created, cut, heat treated, machined, manufactured, modified, painted, produced, surface coated, or conjured partially or completely into the final form in which it will be used on the ROBOT
FIELD	a 26 ft. 7 in. by 54 ft. 1 in. carpeted area, bound by and including the inward-facing surfaces of the GUARDRAILS and two (2) CASTLES
FIELD STEWARDS	REFEREES, FTAs, or other staff working around the FIELD
FMS	FIELD Management System as described in the FMS Whitepaper

Term	Definition
FOUL	a penalty assessed by a REFEREE which credits the opponent with 5 points
FRAME PERIMETER	the polygon defined by the outer-most set of exterior vertices on the ROBOT (without the BUMPERS attached) that are within the BUMPER ZONE. To determine the FRAME PERIMETER, wrap a piece of string around the ROBOT at the level of the BUMPER ZONE - the string describes this polygon
FTA	<i>FIRST</i> Technical Advisor
GOAL	an opening in the TOWER in which BOULDERS may be scored
GUARDRAIL	a system that consists of transparent polycarbonate shields supported on the top and bottom by aluminum extrusion
Herald	the Emcee of the event
HUMAN PLAYER	a pre-college student DRIVE TEAM member primarily responsible for managing and introducing game pieces onto the FIELD throughout the MATCH
HUMAN PLAYER STATION	an area on the side of each CASTLE through which HUMAN PLAYERS feed BOULDERS on to the FIELD
Kit of Parts (KOP)	the collection of items listed on any Kickoff Kit Checklists, distributed via <i>FIRST</i> Choice, or obtained via a Product Donation Voucher (PDV), etc.
LINEUP	the list of three (3) Teams and their selected PLAYER STATIONS submitted by an ALLIANCE CAPTAIN to play in a <i>FIRST</i> Championship Division Playoff MATCH or a MATCH on the Einstein FIELDS
MATCH	a two (2) minute and thirty (30) second period of time in which ALLIANCES play <i>FIRST STRONGHOLD</i>
MECHANISM	a COTS or custom assembly of COMPONENTS that provide specific functionality on the ROBOT. A MECHANISM can be disassembled (and then reassembled) into individual COMPONENTS without damage to the parts
MIDLINE	a line of 2 in. white gaffers tape that bisects the length of the FIELD
MPX	MyRIO eXpansion Port, the expansion port on the roboRIO
NEUTRAL ZONE	an infinitely tall volume formed by, but not including, the BERMS, the GUARDRAILS and OUTER WORKS
OPERATOR CONSOLE	the set of COMPONENTS and MECHANISMS used by the DRIVERS and/or HUMAN PLAYER to relay commands to the ROBOT
OUTER WORKS	an infinitely tall volume bordered by, but not including, the GUARDRAIL, the SECRET PASSAGE, and the bottom edges of its PLATFORM Ramps. It hosts a series of five (5) DEFENSES, five (5) PLATFORMS, and five (5) Shields arranged in a line across the FIELD and is designed to impeded the passage of ROBOTS and BOULDERS in to the COURTYARDS.
PASSIVE CONDUCTORS	any device or circuit whose capability is limited to the conduction and/or static regulation of the electrical energy applied to it (e.g. wire, splices, connectors, printed wiring board, etc.)
PCM	Pneumatic Control Module
PDP	Power Distribution Panel
PLATFORM	a 4 ft. 2 in. wide, 2 ft. deep and 3 in. tall base for a DEFENSE and associated ramps
PLAYER STATION	one (1) of three (3) assigned positions behind a CASTLE WALL from where a DRIVE TEAM operates their ROBOT

Term	Definition
RS	Ranking Score, the total number of Ranking Points earned by a Team throughout their Qualification MATCHES
RP	Ranking Point + a unit credited to a Team based on their ALLIANCES' performance in Qualification Matches
REACH	an act performed by a ROBOT, such that at the end of the AUTO period, any part of a ROBOT'S BUMPERS are within the opponent's OUTER WORKS
RED CARD	a penalty assessed for egregious ROBOT or <i>FIRST</i> Robotics Competition Team member behavior which results in a Team being DISQUALIFIED
REFEREE	an official who is certified by <i>FIRST</i> to enforce the rules of <i>FIRST STRONGHOLD</i>
ROBOT	an electromechanical assembly built by an <i>FIRST</i> Robotics Competition Team to perform specific tasks when competing in <i>FIRST STRONGHOLD</i> . It includes all of the basic systems required to be an active participant in the game: power, communications, control, BUMPERS and movement. The implementation must obviously follow a design approach intended to play <i>FIRST STRONGHOLD</i> (e.g. a box of unassembled parts placed on the FIELD or a ROBOT designed to play a different game would not satisfy this definition)
RUNG	a bar mounted on a TOWER face that is 1 ft. 9 in. wide and constructed of 1-1/2" Steel DOM Tubing
SCALE	an act performed by a ROBOT, such that at the conclusion of the MATCH, it is in contact with a unique RUNG, and has all of its BUMPERS fully above the height of the low GOALS.
SECRET PASSAGE	a rectangular area in front of each HUMAN PLAYER STATION. As introduced in Section 2 (2.1 Zones & Markings) , each ALLIANCE has a SECRET PASSAGE; an infinitely tall, 4 ft. 5-1/2 in. wide, 23 ft. 11-1/2 in. deep volume defined by BERMS, the GUARDRAIL and the CASTLE WALL
SHIELD	a 3/8" thick polycarbonate sheet, 4 ft. deep and 2 ft. tall separating each DEFENSE, and the OUTER WORKS from the SECRET PASSAGE BERM
SPY BOX	a 6 ft. wide by 2 ft. deep, infinitely tall volume, bounded by and including 2 in. white gaffers tape, located adjacent to the to the edge of the opposing CASTLE and the edge of the carpet.
STANDARD	a Team's flag to be flown over their PLAYER STATION on the FIELD during MATCHES
STARTING CONFIGURATION	the physical configuration and orientation of the ROBOT when the MATCH is started. This is the state of the ROBOT immediately before being Enabled by the Field Management System, before the ROBOT takes any actions, deploys any mechanisms, or moves away from the starting location. This configuration is static, and does not change during a single MATCH (although it may change from MATCH to MATCH). In the STARTING CONFIGURATION, no part of the ROBOT may extend outside the vertical projection of the FRAME PERIMETER, with the exception of minor protrusions such as bolt heads, fastener ends, rivets, etc.
STARTING LINE	a 2 in. white gaffers tape line that is the width of the CASTLE and is 2 ft. 6 in. from the CASTLE WALL
STRENGTH	a measure of DEFENSE or TOWER health
SURROGATE	a Team randomly assigned by the FIELD Management System to play an extra Qualification MATCH

Term	Definition
TECH FOUL	a penalty assessed by a REFEREE which credits the opponent with 5 points and one (1) TOWER STRENGTH
TELEOP	the final two (2) minutes and fifteen (15) seconds of a MATCH in which ROBOTS may be directly controlled by DRIVERS and/or HUMAN PLAYERS
TIMEOUT	a period of up to six (6) minutes between MATCHES used to pause Playoff MATCH progression
TOWER	the part of the CASTLE constructed between PLAYER STATIONS two (2) and three (3) with three (3) faces, three (3) RUNGS, five (5) GOALS, a BATTER, and a CORRAL
VENDOR	a legitimate business source for COTS items that satisfies criteria listed in Section 4 (4.1 Overview)
VRM	Voltage Regulator Module
WEAKENED	the state of a TOWER if its STRENGTH is at or below zero (0)
WITHHOLDING ALLOWANCE	a static set of FABRICATED ITEMS that shall not exceed 30 lbs., brought to an event (or Robot Access Period) in addition to the bagged items, to be used to repair and/or upgrade their ROBOT
YELLOW CARD	a warning issued by the Head REFEREE for egregious ROBOT or Team member behavior

FIRST®, the *FIRST*® logo, *FIRST*® Robotics Competition, *Coopertition*®, *Gracious Professionalism*® are registered trademarks, and *Sport for the Mind*™ and *STRONGHOLD*SM are common law trademarks, of the United States Foundation for Inspiration and Recognition of Science and Technology (*FIRST*®). ©2016 *FIRST*®. All rights reserved.

Official *FIRST*® Robotics Competition teams and Partners are permitted to make reproductions of this manual for team and Partner use only. Any use, reproduction, or duplication of this manual for purposes other than directly by the team or Partner as part of *FIRST*® Robotics Competition participation is strictly prohibited without specific written permission from *FIRST*.