

MAXTORQUE

High-performance valve products

High-Performance Worm Gear Operators

The Cameron portfolio of MAXTORQUE* high-performance valve products includes worm gears that feature patented autolocking technology.

High efficiency

Featuring a double-enveloping worm design, MAXTORQUE product worm gears

- reduce turns to close by up to 75%, increasing operational efficiency
- reduce rim pull, improving worker HSE profile
- increase closing speed by up to 75%, improving process control
- reduce required input torque, minimizing cost of actuation packages
- reduce weight and piping loads with smaller actuation packages
- reduce backlash, minimizing seepage around the ball or disc and reducing fluttering.

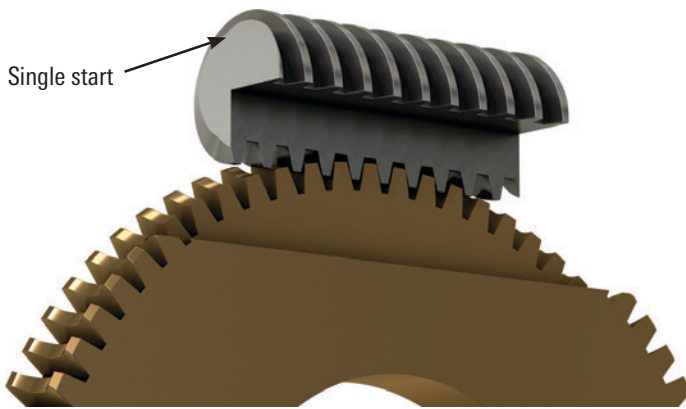

Standard worm gear—1.23 to 2.98 teeth in contact.

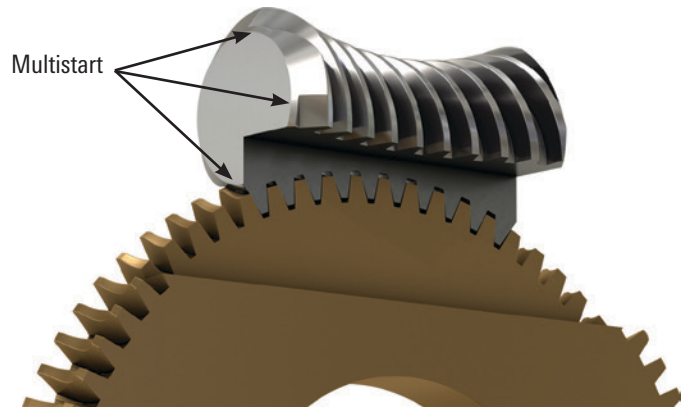

MAXTORQUE product worm gear—6 to 13+ teeth in contact.

Durability in design

MAXTORQUE product worm gears are engineered with

- 6 to 13+ teeth in contact compared with 1.23 to 2.98 for standard gears, which enables higher torque capability and significantly less backlash
- novel tooth shape and high-contact ratio that reduce contact and bending stress
- manganese bronze gearset for increased lubricity, strength, and corrosion resistance
- variety of housing material options
- high-graphite-based grease for smooth operation (ductile iron standard)
- roller bearings versus traditional needle bearings
- bronze bearing on output
- double-sealing O-ring system that reduces fluid and particulate ingress into the gear.

MAXTORQUE Products

Enhanced valve solutions

Features

Quality in manufacturing

- International Protection Marking rating of IP68
- Torque-handling capability in excess of 1,000,000 ft.lbf [1,355,810 N.m]
- Made in USA

LW, BW, and MW Series

- 3,300 to 1,000,000 ft.lbf [4,475 to 1,355,810 N.m]
- Available in 360° design

Additional advantages

- Superior sealing
- Bronze bearing
- Modular adaptation
- Ductile iron housing
- Roller bearings

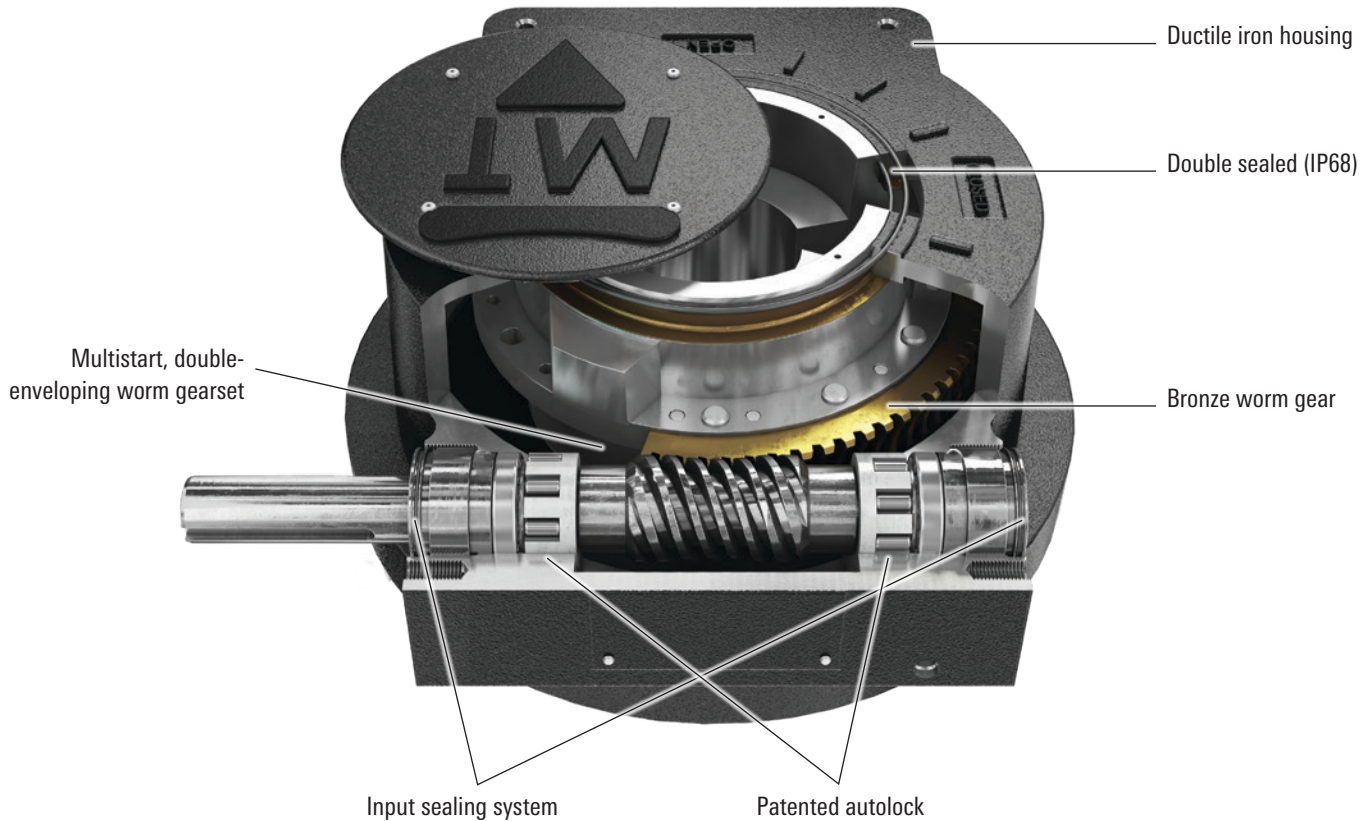

Turn Reduction

Valve Size, in [mm]	Rated Torque, ft.lbf [N.m]	Handwheel Diameter, in [mm]	Ratio	Mechanical Advantage	Break Rim Pull, lbf [N]	Turns to Close		Total Turn Reduction
						MAXTORQUE Products	Conventional Products	
16 [406]	6,250 [8,475]	24 [610]	150	82	55 [245]	38	112.5	75
18 [457]	8,333 [11,300]	24 [610]	152	82	75 [334]	38	112.5	75
20 [508]	16,667 [22,600]	24 [610]	156	106	76 [338]	39	190	151
24 [610]	16,667 [22,600]	36 [914]	156	106	76 [338]	39	190	151
30 [762]	33,333 [45,000]	36 [914]	391	234	62 [276]	98	297	199
36 [914]	58,333 [79,000]	36 [914]	470	285	75 [334]	118	297	180
40 [1,016]	58,333 [79,000]	36 [914]	730	444	76 [338]	183	428	246

Rising Stem Applications

High-ratio, small-envelope, robust worm gear solutions

Features

- From 10,000- to >300,000-ft.lbf [13,550- to >406,745-N.m] torque
- More than 2,000,000-lbf [8,896,440-N] thrust
- Highly efficient, double-enveloping bronze alloy worm gearset
- High-quality thrust bearings
- Manual or motorized applications
- Dual-input solution that reduces turns to close by up to 4× compared with manual applications
- Smaller, stronger, faster, and more cost effective compared with large bevels
- Quick delivery
- Easy accommodation of mounting adaptation and stem covers



High-Thrust Spurs

High-torque, high-thrust rising stem solutions

Features

- From 5,000- to >300,000-ft.lbf [6,780- to >406,745-N.m] torque
- More than 2,000,000-lbf [8,896,440-N] thrust
- Highly efficient spur gear drivetrain that uses heat-treated steel
- High-quality thrust bearings
- Available double-idler gearset that enables high torque while maintaining a low profile
- Stronger, faster, and more cost effective compared with large bevels
- Quick delivery
- Application engineered
- Easy accommodation of mounting adaptation and stem covers
- Available high-temperature packages

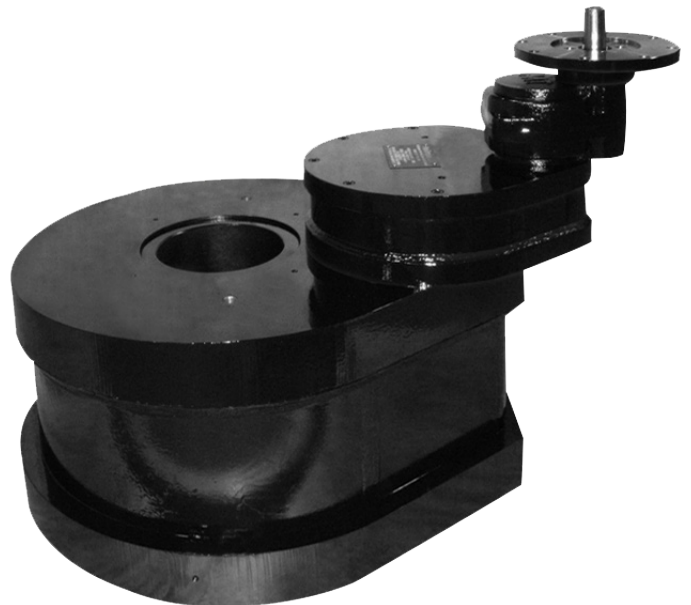

MAXTORQUE Product Solutions

Subsea applications

Advantages

- High-efficiency, double-enveloping bronze alloy worm gearset
- Fully double-sealed gears and accessories
- Hyperbaric testing
- Active and passive pressure-compensation systems to 10,000 ft [3,050 m]
- ROV interface, buckets, panels, indicators, hot stab, and flushing systems
- Manual operators, tethered handwheels, and tactical position indicator



MAXTORQUE products for complex subsea operations.

Temperature Compensators

Purpose engineered, quality manufactured, and performance tested

Features

- Actuator-to-valve direct interface mounting design that is ideal for new projects or retrofits
- Proven Belleville spring design
- Unique floating thrust-bearing stem nut cartridge
- Stem sizes up to 10 in [254 mm]
- Growth up to ¼ in [6.35 mm]
- Single- or double-acting designs

Benefits

- Extends valve life
- Reduces wear and damage to the actuator and gear
- Decreases NPT and downtime through quick delivery
- Improves operations with application-specific engineering

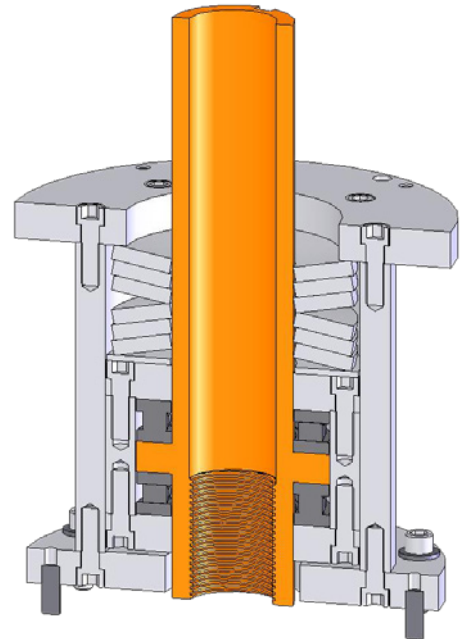

Declutch and Manual Overrides

Features

- Highly efficient, double-enveloping bronze alloy worm gearset
- Torque tube design with robust lever engagement
- Broad torque range from 4,167 to 41,667 ft.lbf [5,650 to 56,500 N.m]
- Direct mount to valve
- One-piece drive adaptor
- 50%–75% reduced turns to operate and rim pull
- Reduced handwheel size

Benefits

- Saves rig space through compact design
- Increases uptime with reduced turns to operate and rim pull requirements



Subsea and Offshore Applications

High-quality manufacturing and dependable performance

Features

- Torque range to 295,000 ft.lbf [400,000 N.m]
- Highly efficient, double-enveloping 4140 HT bronze alloy worm and gearset
- Active and passive pressure-compensation systems up to 98 in [2,500 mm]; hyperbaric tested up to 98 in
- ROV buckets (horizontal and vertical), panels, indicators, hot stab, and flushing
- Manual operators, tethered handwheels, and tactile position indicators
- Check valve lock open, special materials, and other custom solutions

Benefits

- 50% or more reduction in turns to close and rim pull
- Significantly increased tooth contact, load capacity, and life capacity
- Ensured integrity with unique double O-ring sealing system
- Greater torque capacity in smaller packages
- Reduced head height with direct mount
- Increased efficiency through smaller actuator and gear



MAXTORQUE



cameron.slb.com/maxtorque

*Mark of Schlumberger
Other company, product, and service names
are the properties of their respective owners.
Copyright © 2018 Schlumberger. All rights reserved. 16-VL-185021

