

MODEL MX06 and MX09 1/4" OVAL GEAR FLOWMETER

INSTRUCTION MANUAL



To the Owner

Please read and retain this instruction manual to assist you in the operation and maintenance of this product.

This manual contains connection and operating in-structions for the MX series Flowmeters with Pulse outputs.

Models with a Liquid Crystal Display have an addi-tional LCD instruction manual supplied. If you need further assistance, contact your local representative or distributor for advice.

This Flow Meter has incorporated the oval rotor prin-cipal into its design. This is proven to be a reliable and highly accurate method of measuring flow. Exceptional repeatability and high accuracy over a wide range of fluid viscosities and flow rates are features of the oval rotor design.

With a low pressure drop and high pressure rating oval rotor flow meters are suitable for both gravity and (in-line) pump applications.

Installation

Pre-installation checks	Page 3
Operating Principle	Page 3
Installation Procedure	Page 3

Maintenance Procedure

Disassembly	Page 4
Reassembly	Page 4

Flowmeter Specifications

Flowmeter Specifications	Page 5
Electrical Specifications	Page 5
Wiring Diagram - Standard Pulsar	Page 6
Wiring Diagram - PCB sensor	Page 7
Wiring Diagram—Intrinsically Safe Switch	Page 8
Wiring Diagram - High Temperature Switch	Page 9

Service

Troubleshooting Guide	Page 10
Maintenance Resources	Page 10
Exploded Diagram	Page 11
Spare Parts Kits	Page 12
Wetted Parts	Page 13

General

Pressure Drop Graphs	Page 14
Dimensional Diagrams	Page 15-16

IMPORTANT INFORMATION



FLUID COMPATABILITY

Before use, confirm the fluid to be used is compatible with the meter. Refer to Industry fluid compatibility charts or consult your local representative for advice.



STRAINER

To prevent damage from dirt or foreign matter it is recommended that a Y or Basket type 200 mesh strainer be installed as close as possible to the inlet side of the meter.

When a strainer is installed it should be regularly inspected and cleaned. Failure to keep the strainer clean will dramatically effect flow meter performance.

Contact your local representative for advice.



AIR PURGE / LINE PRESSURE

To prevent damage caused by air purge slowly fill the meter with fluid.

To reduce pressure build-up turn off the at the end of each day.



REED SWITCH

The reed switch can cause inaccurate rate counts when used with high speed counters. It is advised that a low speed counter is used or alternatively a denounce circuit be installed.

OPERATING PRINCIPLE

Fluid passing through the meter causes the rotors to turn, as shown below.

One of the rotors (the active rotor) is fitted with magnets.

The passing of the magnets are picked up by the sensing elements (Reed and Hall Effect sensors) located in the Pulser Circuit Board.

The excitation of these switches provides a 'Raw Pulse Output' which relates to the K-Factor. (e.g. $KF\ 400 = 400\ pulses\ per\ litre\ of\ fluid\ passed$)

This Pulse Output Signal can either be fed directly to an external receiving element (e.g. Data Logger or PLC) or alternatively to an LC Display which conditions the Pulse input signal to display volume of fluid passed. (e.g. *Display 1 Litre per for every 400 pulses received*)

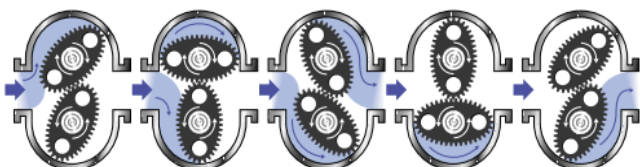

INSTALLATION PROCEDURE

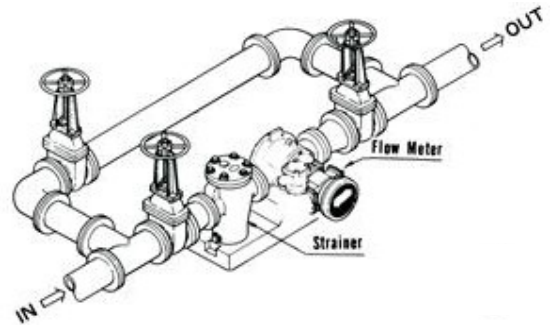

1. It is recommended that when setting up pipe work for meter installations, a bypass line be included in the design. This provides the facility for a meter to be removed for maintenance without interrupting production. (see figure above)
2. Use thread sealant on all pipe threads.
3. For pump applications ensure pipe work and Meter have the appropriate working pressure rating to match the pressure output of the pump. Refer to Meter Specifications section for further details.
4. Install a wire mesh strainer, Y or basket type 200 mesh (74 micron), as close as possible to the inlet side of the meter.
5. Note: The Flowmeter can accept flow in any direction.
6. The meter can be installed in any orientation as long as the meter shafts are in a horizontal plane. (Refer to diagram below for correct installation)

Note: Incorrect installation can cause premature wear of meter components.

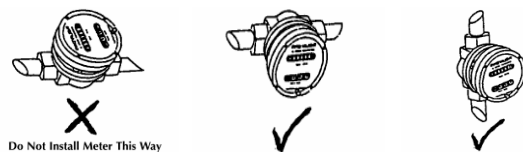

The LC display may removed by loosening the 4 mounting screws and be orientated as required.

7. Do not over tighten meter connections. .
8. It is important that after initial installation you fill the line slowly, high speed air purge could cause damage to the rotors.
9. Test the system for leaks.
10. Check the strainer for swarf or foreign material, after the first 200 litres check periodically, particularly if the flow rate is noted to be decreasing.

MAINTENANCE PROCEDURE

DISASSEMBLY

Note: Maintenance can be carried out to the liquid crystal displays and pulse output modules without having to remove or isolate the meter from the process line.

When maintenance to any other part of the meter is required, the meter must be isolated and the line pressure released.

Refer to the *exploded parts* diagram on (see Fig for item numbers.

Note: It is advisable to mark all components with a marker pen before disassembly, to ensure all the components are replaced to their correct position during the reassembly process.

1. Remove the meter cap by loosening the bolts on the underside of the meter body. (see FIG 1)
2. Remove the O-Ring from the O-Ring groove in the meter cap.
Wipe clean of grease and store in clean place
3. Remove rotors from the meter body
4. Remove the shafts from the meter body.

REASSEMBLY

1. Before reassembling check the condition of the rotors (replace if necessary).
2. Replace the shafts into the meter body.
3. There are two Rotor Types.
Active and **Neutral**.
The Active Rotor can be identified by a **Dimple** on the face of the rotor. (see Fig 2)

Caution: The active rotor is always fitted nearest 'dimple' on the meter body (see FIG 3)

Replace Active Rotor.

Check the dimpled face (smooth side) of the rotor is the lead-in face when fitting onto the shaft and into the meter body. (see Fig 2).

Replace Neutral Rotor. Check that the smooth side of the rotor is the leading face when fitting onto the shaft. (see FIG 2)

Fit the neutral rotor onto the shafts ensuring that the rotor pair are at 90 degrees to one another. (see FIG 3)

Check their operation by turning either of the rotors. If the rotors are not in mesh correctly, or do not move freely, remove one of the rotors and replace correctly at 90 degrees to one another

4. Smear the O-Ring with a light film of grease.
Replace the O-Ring into groove in the meter cap.
The O-Ring will need to be replaced if it has grown or is damaged in anyway.

5. Replace the meter cap.

6. Insert the cap head screws and tighten in a diagonal sequence 1, 5, 7, 3, etc.

Torque = 6.5 Nm

7. Test the meter by turning the rotors with a finger or by applying very low air pressure (no more than a good breath) to one end of the meter, before returning the meter to service.

FIG 1



FIG 2

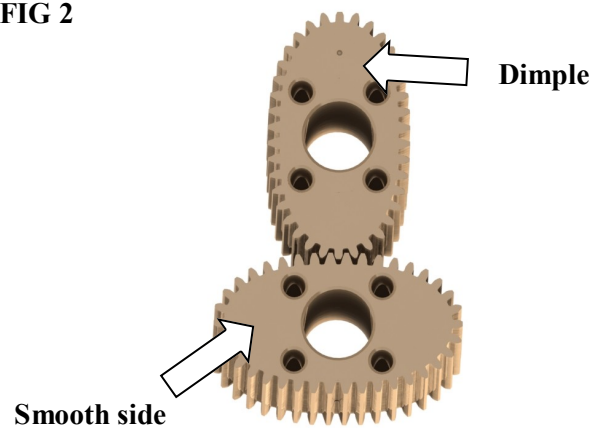
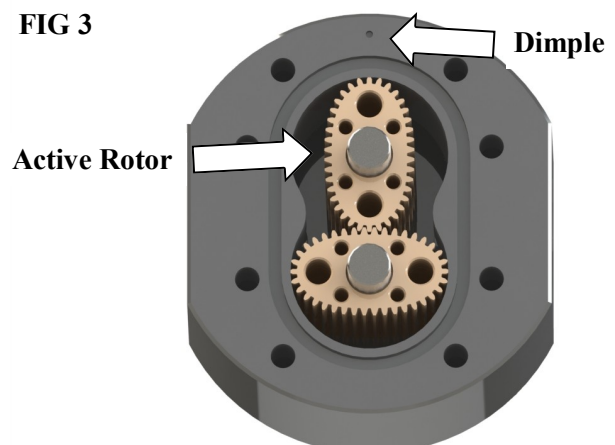

FIG 3



FLOWMETER SPECIFICATIONS

		Metric	US
Flow Range	Below 5 cP	2 to 100 LPH	0.5 to 26 GPH
	5 to 1000 cP	0.5 to 100 LPH	0.13 to 26.4 GPH
K-Factor	(Sensor Pulses per Unit of Measure)	1000 pulses/L	3785.4 pulses/G
Max Temperature	(model MX06F)	-40°C - 80°C	-40°F - 176°F
	(models MX06S)	-40°C - 120°C	-40°F - 248°F
	(models MX06P)	-40°C - 150°C	-40°F - 302°F
Maximum Operating Pressure ¹		6895 kPa	1000 psi
Accuracy of Reading		±1%	

1. Conforms to Directive 97/23/EC—Cat 1

Model MX09		Metric	US
Flow Range	Below 5 cP	25 to 500 LPH	6.6 to 132 GPH
	5 to 1000 cP	15 to 500 LPH	4 to 132 GPH
K-Factor	(Sensor Pulses per Unit of Measure)	Refer to Flowmeter Data Plate	
Max Temperature	(model MX09F)	-40°C - 80°C	-40°F - 176°F
	(models MX09S)	-40°C - 120°C	-40°F - 248°F
	(models MX09P)	-40°C - 150°C	-40°F - 302°F
Maximum Operating Pressure ¹		6895 kPa	1000 psi
Accuracy of Reading		±1%	

1. Conforms to Directive 97/23/EC—Cat 1

High Viscosity Applications

Ensure the Flowmeter is fitted with 'High Viscosity Rotors' if the fluid being metered is 1000 cP or above

High Viscosity Rotors	For Fluids above 1000 Centipoise (cP)
<i>*Note: High Viscosity Rotor option available for models MX09S and MX09P only.</i>	

ELECTRICAL SPECIFICATIONS

The MX Flow meter series is supplied with either a Blind Pulser and Digital Display option. Please note the wiring diagrams in the following pages are for the **Blind Pulser Output Modules** and the **PCB** (Sensor Board), which is responsible for providing a Raw Pulse input to the LC display

If the Flow meter is supplied with an LC Display fitted, please consult the appropriate Instruction Manual, as advised below, for all programming and wiring instructions.

Output option:	type 'D'	type 'E'	type 'F'	type "G"	type "H"	
Display Type :	PR	PRA	ER	ERA	ERB	ERS (<i>remote mount only</i>)
Display Part Number:	MXD-DS	MXD-ES	MXD-ES	MXD-GS	MXD-HS	ERS-RMP / ERS-RMA
Instruction Sheet:	DR013	DR014	MS574	MS392	MS476	MS351

Analogue Output (4-20mA)

Analogue outputs are available as an auxiliary display signal by including either of the following LC displays with your flowmeter. These may be fitted to the meter or remote (wall mount) types.

- PRA** 12mm LC Display with analogue output module
- ERA** 17mm LC Display with analogue output module

Pulsar Specifications

Output Signals	Standard Pulse Meter		2x Digital (Square Wave)
Reed Switch (Mechanical Sensor)	Current	Maximum	500mA
	Voltage	Maximum	30V DC
	Contact Rating	Maximum ¹	10W
Hall Effect IC (Electronic Sensor)	Maximum Current		7.5mA
	Operating Voltage		4.5V to 24V DC
	Transistor Type		Open-Collector NPN

1. Contact rating maximum is 10W. Neither current nor voltage maximums should be exceeded in achieving this.

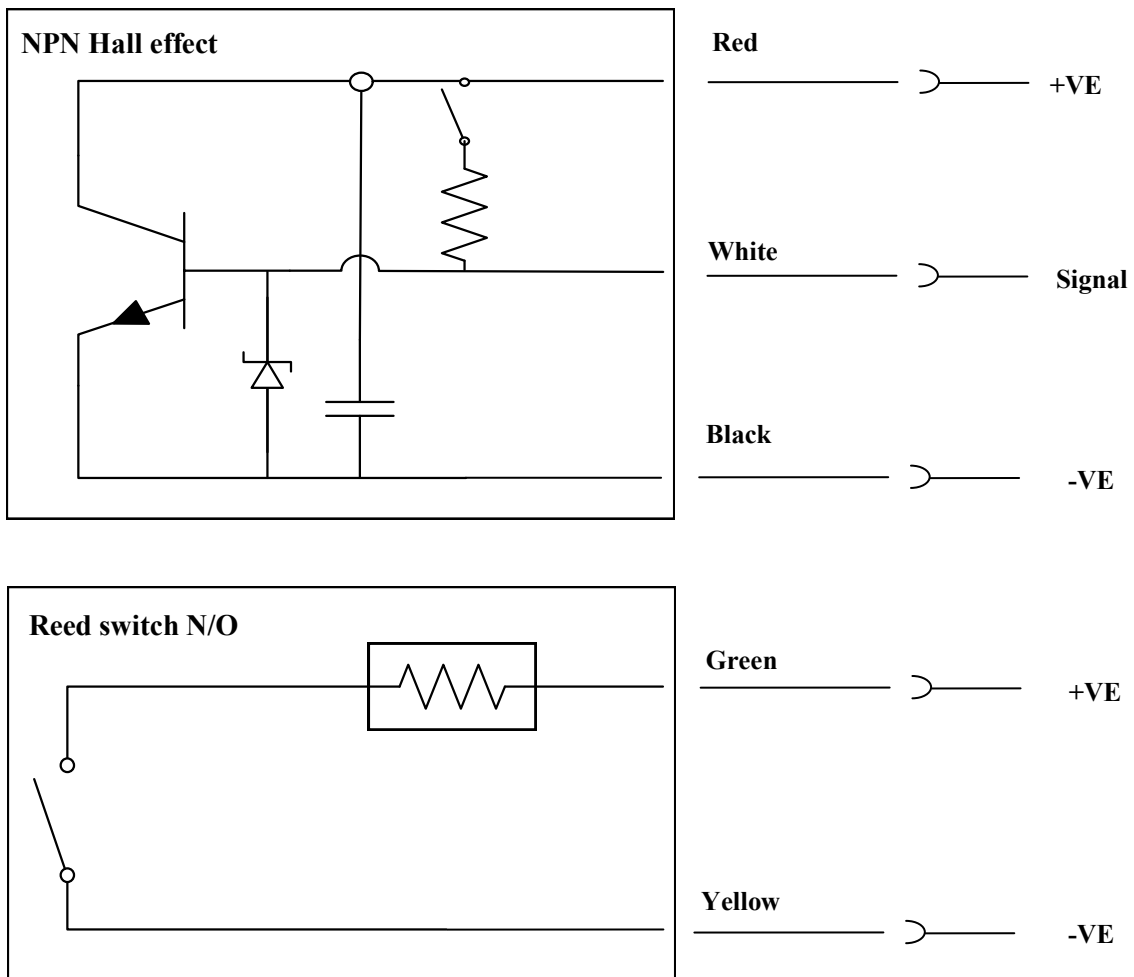



Reed Switch

To maximise the life of the reed switch contacts, the pulse board comes equipped with a 1k8Ω current limiting resistor in series with the reed switch as standard. These resistors are user swappable should you require a different value for your system.



NPN Open Collector Hall Effect Sensor

The output for the hall effect sensor is NPN (current sinking, open collector). For correct operation, it is advisable to have a pull-up resistor installed. The hall effect sensor is equipped with a 1k8Ω pull-up resistor between signal and supply as standard. This in-built pull-up resistor can be bypassed by moving the jumper pin to the off position if required. A pull-up resistor of your choosing can be installed between signal and supply, provided the in-built pull-up resistor be bypassed first.

Pulser Specifications

Output Signals	Standard Pulse Meter		2x Digital (Square Wave)
Reed Switch (Mechanical Sensor)	Current	Maximum	500mA
	Voltage	Maximum	30V DC
	Contact Rating	Maximum ¹	10W
Hall Effect IC (Electronic Sensor)	Maximum Current		7.5mA
	Operating Voltage		4.5V to 24V DC
	Transistor Type		Open-Collector NPN

1. Contact rating maximum is 10W. Neither current nor voltage maximums should be exceeded in achieving this.

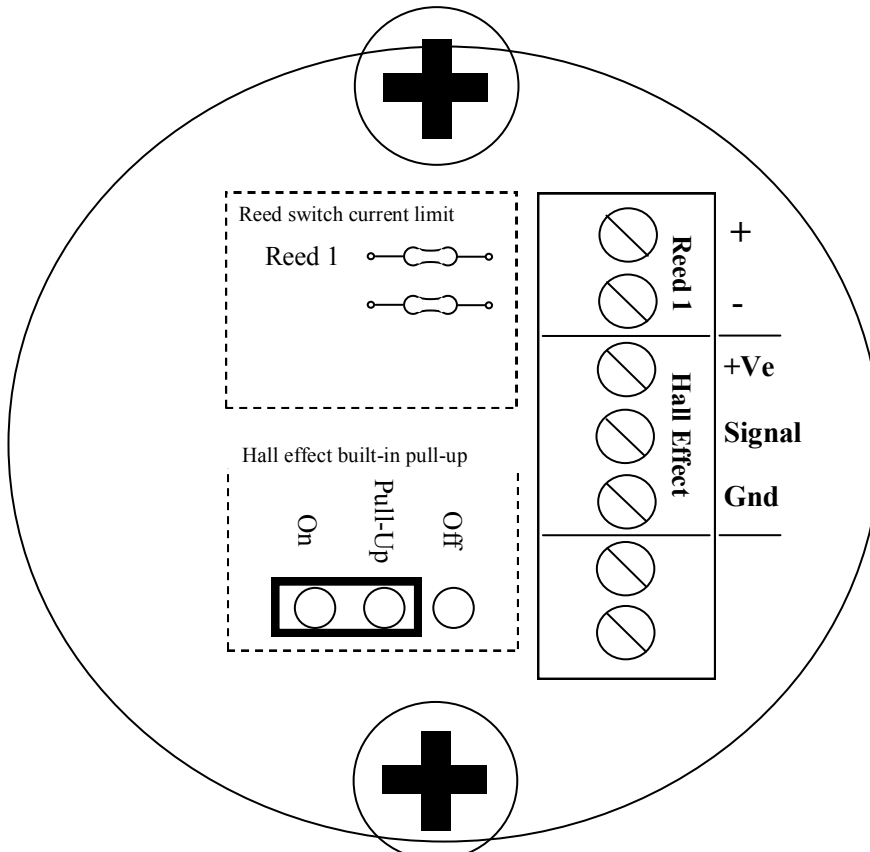

Note:
Local Display is connected to Reed 1



CAUTION: This sensor must be installed with an approved safety barrier.

Pulser Specifications

SENSOR TYPE	Omni Polar	Open-Collector NPN
SPECIFICATIONS	Construction	Stainless Steel Housing
	Operating Voltage	5V to 30V DC
	Maximum Current	15mA
	Temperature Range	-40 - 85oC
		-40 - 185oF

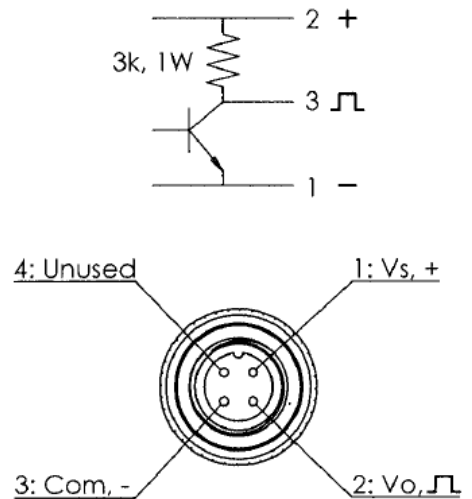
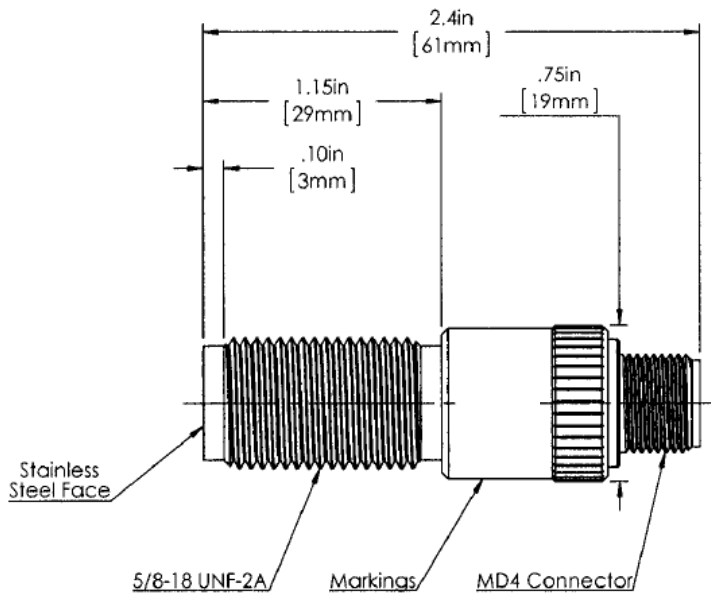

Pulser Specifications

SENSOR TYPE	OMNI POLAR	NPN
SPECIFICATIONS	Construction	Stainless Steel Housing
	Operating Voltage	4.5 to 30V DC
	Maximum Current	18mA
	Temperature Range	-40 - 150oC
		-40 - 302oF

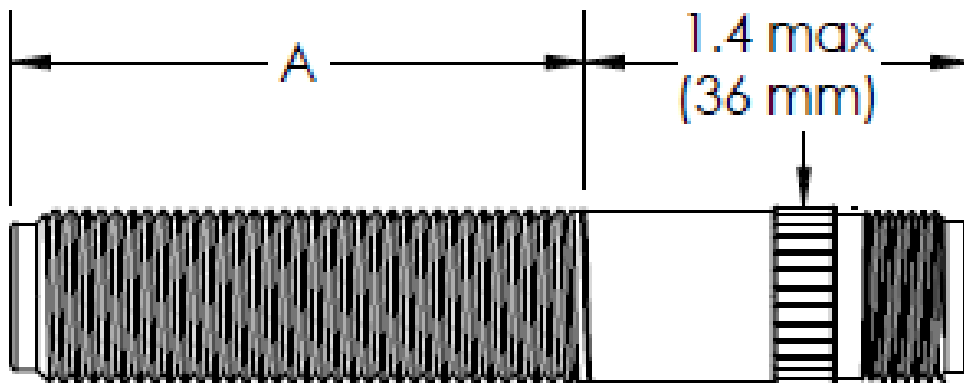
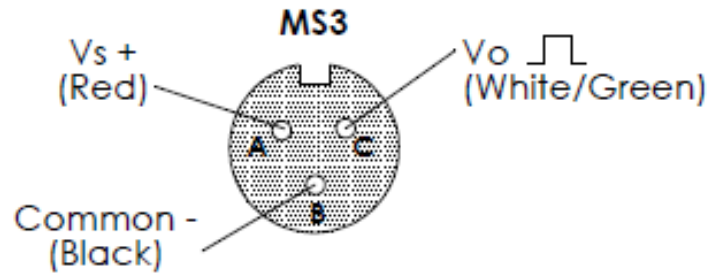

TROUBLESHOOTING GUIDE

Problem	Cause	Remedy
Fluid will not flow through meter	<ul style="list-style-type: none"> a) Foreign matter blocking rotors b) Line strainer blocked c) Damaged rotors d) Meter connections over tightened e) Fluid is too viscous 	<ul style="list-style-type: none"> a) Dismantle meter, clean rotors (strainer must be fitted in line) b) Clean strainer c) Replace rotors (Strainer must be fitted in line) d) Re-adjust connections e) See specifications for maximum viscosity
Reduced flow through meter	<ul style="list-style-type: none"> a) Strainer is partially blocked b) Fluid is too viscous 	<ul style="list-style-type: none"> a) Clean strainer b) See specifications for maximum viscosity
Meter reading inaccurate	<ul style="list-style-type: none"> a) Fluid flow rate is too high or too low b) Air in fluid c) Excess wear caused by incorrect installation 	<ul style="list-style-type: none"> a) See specifications for minimum and maximum flow rates b) Bleed air from system c) Check meter body and rotors. Replace as required. Refer to installation instructions
Meter not giving a pulse signal	<ul style="list-style-type: none"> a) Faulty hall effect sensor b) Faulty reed switch c) Magnets failed 	<ul style="list-style-type: none"> a) Replace PCB Board b) Replace PCB Board c) Replace magnets
LCD register not working	<ul style="list-style-type: none"> a) Battery not connected properly b) Battery flat c) Faulty wiring connections d) Faulty LC Display e) Faulty connection from LC Display 	<ul style="list-style-type: none"> a) Check battery connections b) Replace battery c) Check wiring for loose or faulty connections d) Replace LC Display e) Check wiring connections

MAINTAINENCE VIDEOS

Macnaught provides an comprehensive set of 'Maintenance Videos' to assist the end user in all aspects of service and/or repair of the Flowmeter range.

This web based resource can be accessed via the following URL

http://www.macnaught.com.au/mx_resources

Or by scanning the QR code below.



EXPLODED DIAGRAM

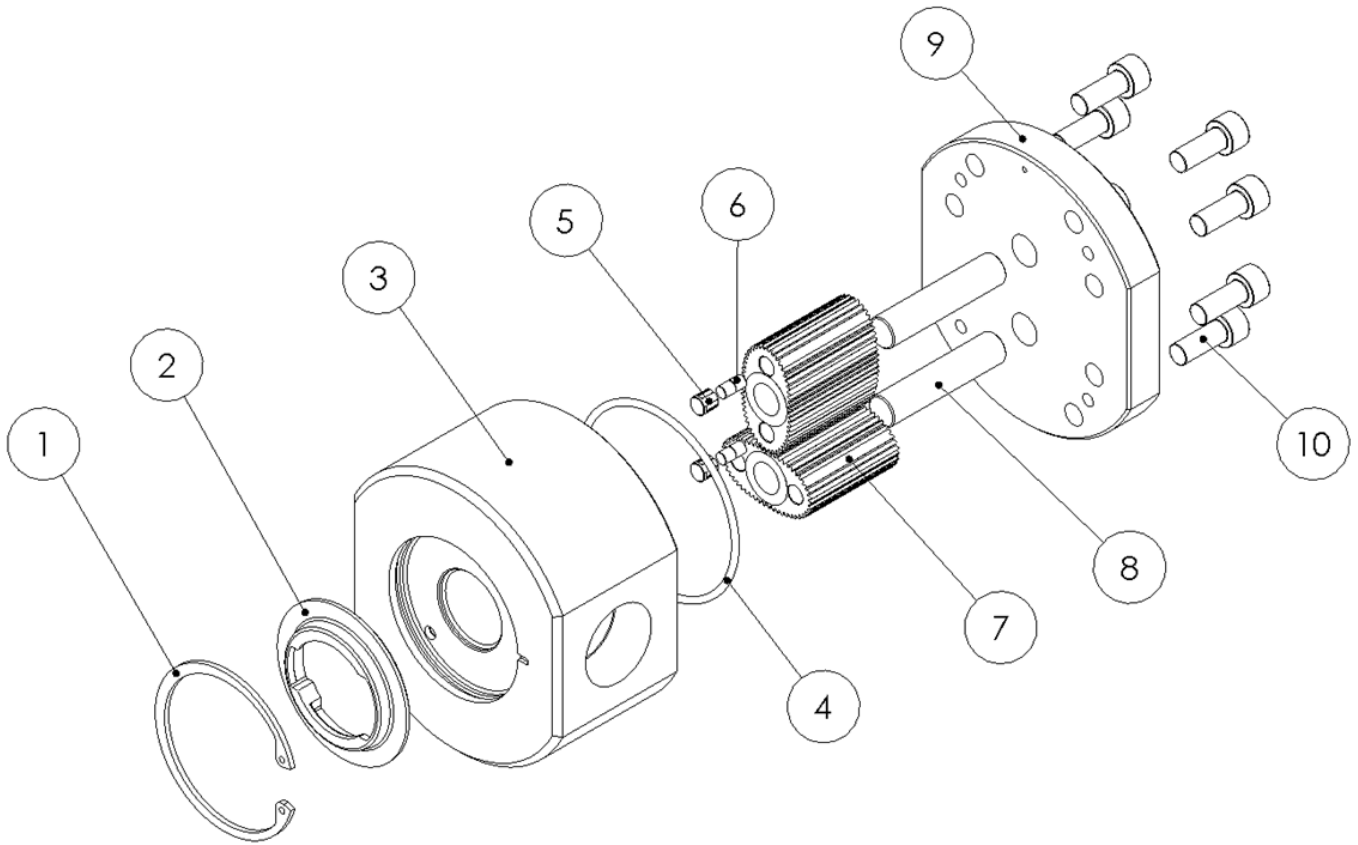

PARTS IDENTIFICATION

METER COMPONENTS	ITEM NO.
CIRCLIP	1
CAM	2
METER BODY	3
METER CAP O-RING	4
MAGNET HOUSING	5
MAGNETS	6
ROTORS	7
ROTOR SHAFTS	8
METER CAP	9
METER CAP SCREWS	10

SPARE PARTS KITS

Spare Kit options, for both Flowmeter and Display/Pulsar modules, are available as replacement components.

- **Pulsar Kit / LC Display Module**
 - Replacement PCB complete with M-Lock electronic housing.
 - LC Display module (Electronic housing not included)
- **Rotor Kit**
 - Rotor assembly (includes Meter Cap bolts and O-Ring)
- **Seal Kit**
 - O-Rings/Gaskets (includes Meter Cap Bolts)

SPARE KITS - FLOWMETER		MX06F	MX06S	MX06P
ROTOR KIT	<i>Standard</i>	MXS06F-rotor	MXS06S-rotor	MXS06P-rotor
	<i>High Temp</i>			MXS06P-HTrotor
SEAL KIT		MXS06F-seal	MXS06S-seal	MXS06P-seal

SPARE KITS - FLOWMETER		MX09F	MX09S	MX09P
ROTOR KIT	<i>Standard</i>	MXS09F-rotor	MXS09S-rotor	MXS09P-rotor
	<i>High Viscosity</i>		MXS09S-HVrotor	MXS09P-HVrotor
	<i>High Temp</i>			MXS09P-HTrotor
SEAL KIT		MXS09F-seal	MXS09S-seal	MXS09P-seal

SPARE KITS – DISPLAY AND PULSER MODULE

Output Type	Description	Pulsar Kit	Display Module only	Display/Pulsar complete
Type A	Standard Pulsar			MXD-AS
Type B	Intrinsically Safe			MXD-BS
Type C	Flameproof			MXD-CS
Type D	PR Digital Register	MXS-PCB-PR	MXS-DIS-PR	MXD-DS
Type E	PRA Digital Register	MXS-PCB-PR	MXS-DIS-PRA	MXD-ES
Type F	ER Digital Register	MXS-PCB-ER	MXS-DIS-ER	MXD-FS
Type G	ERA Digital Register	MXS-PCB-ER	MXS-DIS-ERA	MXD-GS
Type H	ERB Batch Controller	MXS-PCB-ER	MXS-DIS-ERB	MXD-HS
Type T	High Temperature			MXD-TS

WETTED PARTS

WETTED PARTS	MX06/09F	MX06/09S	MX06/09P
METER BODY	Alum	Alum	St.St
METER CAP	Alum	Alum	St.St
ROTORS - Standard	PPS	St.St	PPS
High Viscosity		St.St.	St.St
High Temp			St. St
ROTOR SHAFTS	St.St	St.St	St.St
ROTOR BUSHES		CA	CA
O-RINGS	FKM	K	K

Note: High viscosity rotor option only available for the MX09 SERIES

K - FEP/PTFE Encapsulated

SS - Stainless Steel 316 /304

Al - Aluminium AA610

CA - Carbon

FKM - Viton[®]

PPS - Polyphenylene Sulphide

PRESSURE DROP v VISCOSITY

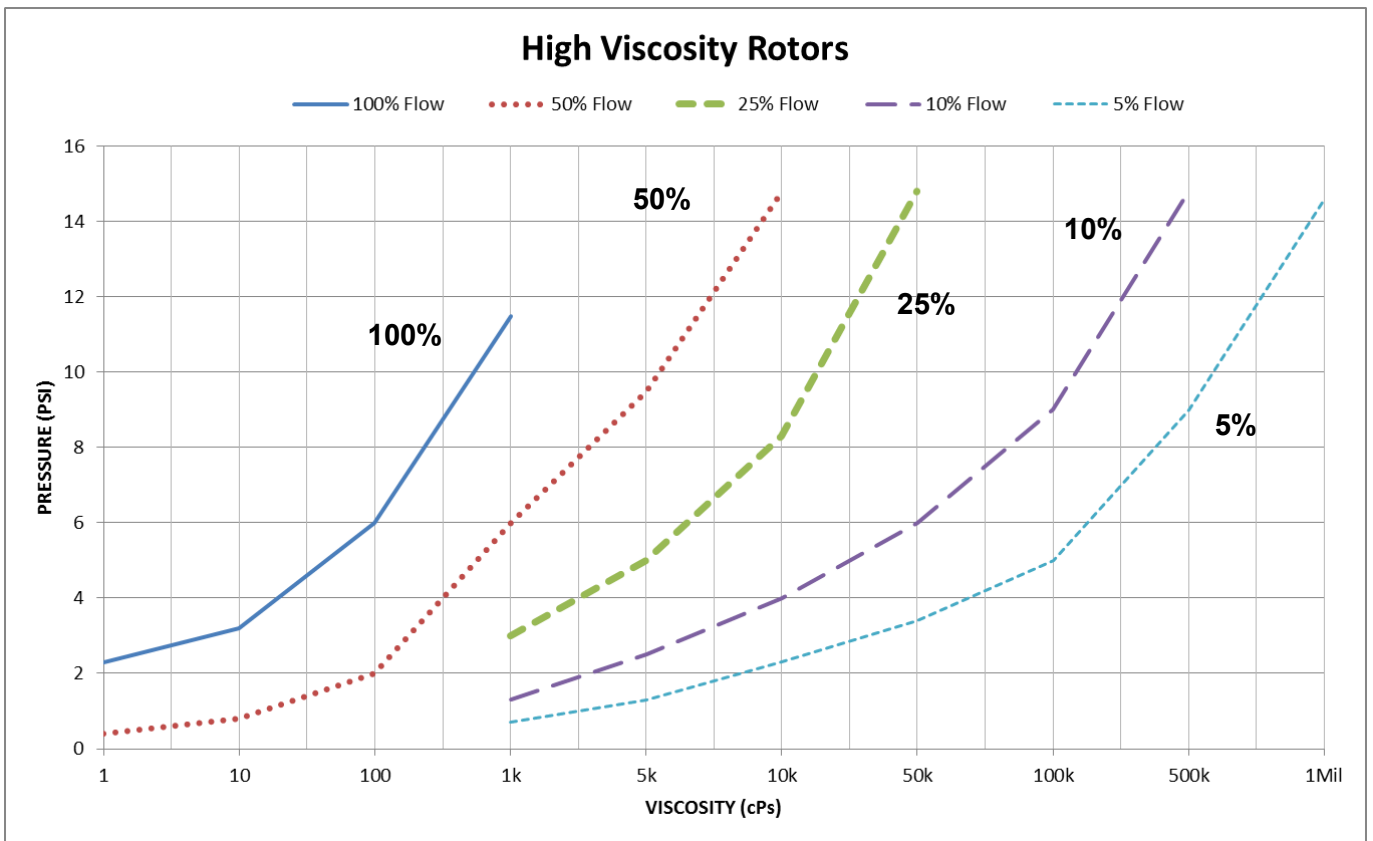
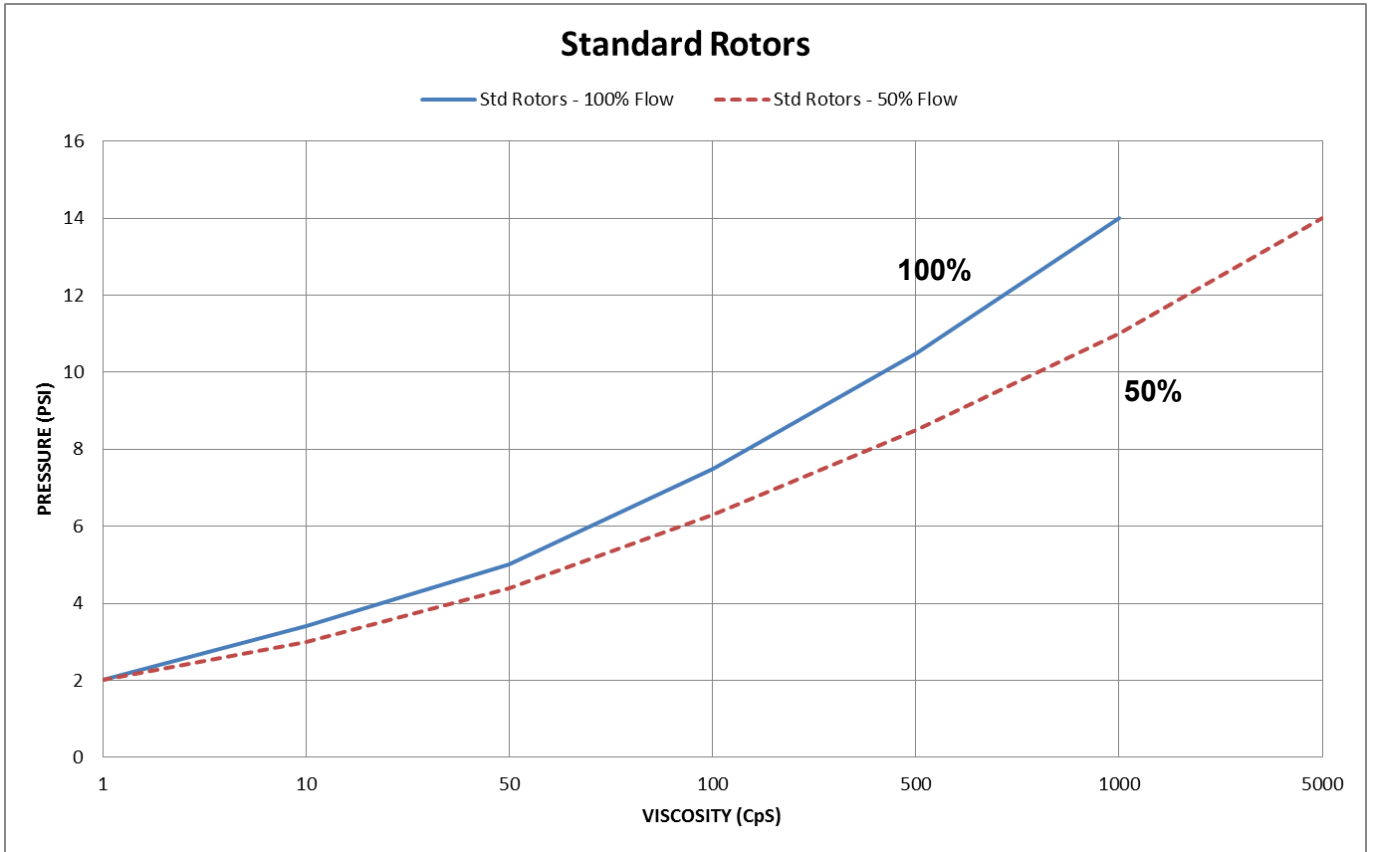

DIMENSIONS

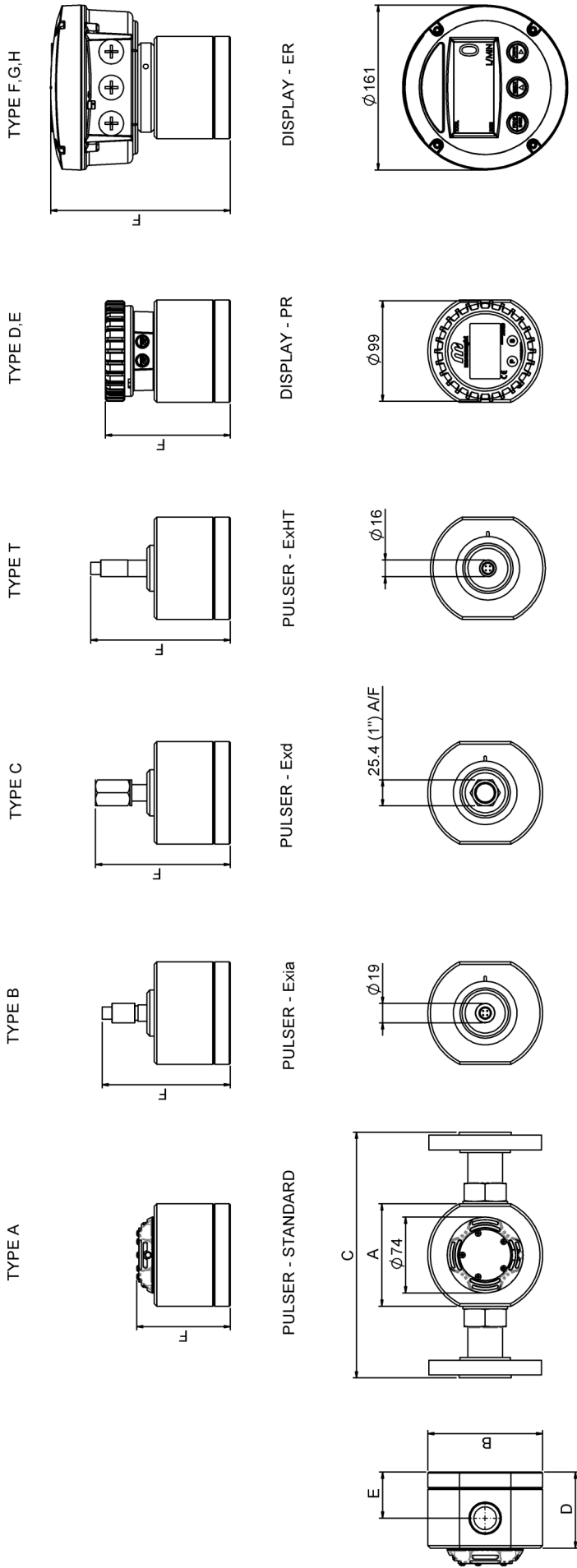

		METER AND FLANGE DIMENSIONS								PULSER AND DISPLAY HEIGHT - F															
METER SIZE	PORT SIZE	A	B	C	D	E	TYPE A	TYPE B	TYPE C	TYPE T	TYPE D,E	TYPE F,G,H	METER SIZE	PORT SIZE	A	B	C	D	E	TYPE A	TYPE B	TYPE C	TYPE T	TYPE D,E	TYPE F,G,H
MX06	1/4"	71	74	N/A	42	25	59	93	100	104	90	143	MX06	1/4"	71	74	N/A	42	25	59	93	100	104	90	143
MX09	1/4"	71	74	N/A	42	24	59	93	100	104	90	143	MX09	1/4"	71	74	N/A	42	24	59	93	100	104	90	143
MX12	1/2"	81	87	N/A	49	28	66	100	107	111	97	150	MX12	1/2"	81	87	N/A	49	28	66	100	107	111	97	150
MX19	3/4"	100	112	N/A	62	37	79	113	120	124	110	163	MX19	3/4"	100	112	N/A	62	37	79	113	120	124	110	163
MX25	1"	100	112	240	75	45	92	126	133	137	123	176	MX25	1"	100	112	240	75	45	92	126	133	137	123	176
MX40	1 1/2"	120	137	240	103	61	120	154	161	165	151	204	MX40	1 1/2"	120	137	240	103	61	120	154	161	165	151	204
MX50	2"	140	163	264	124	72	141	175	182	186	172	225	MX50	2"	140	163	264	124	72	141	175	182	186	172	225

DIMENSIONS

Aluminium Wall Mount bracket to suit models MX06 / MX09

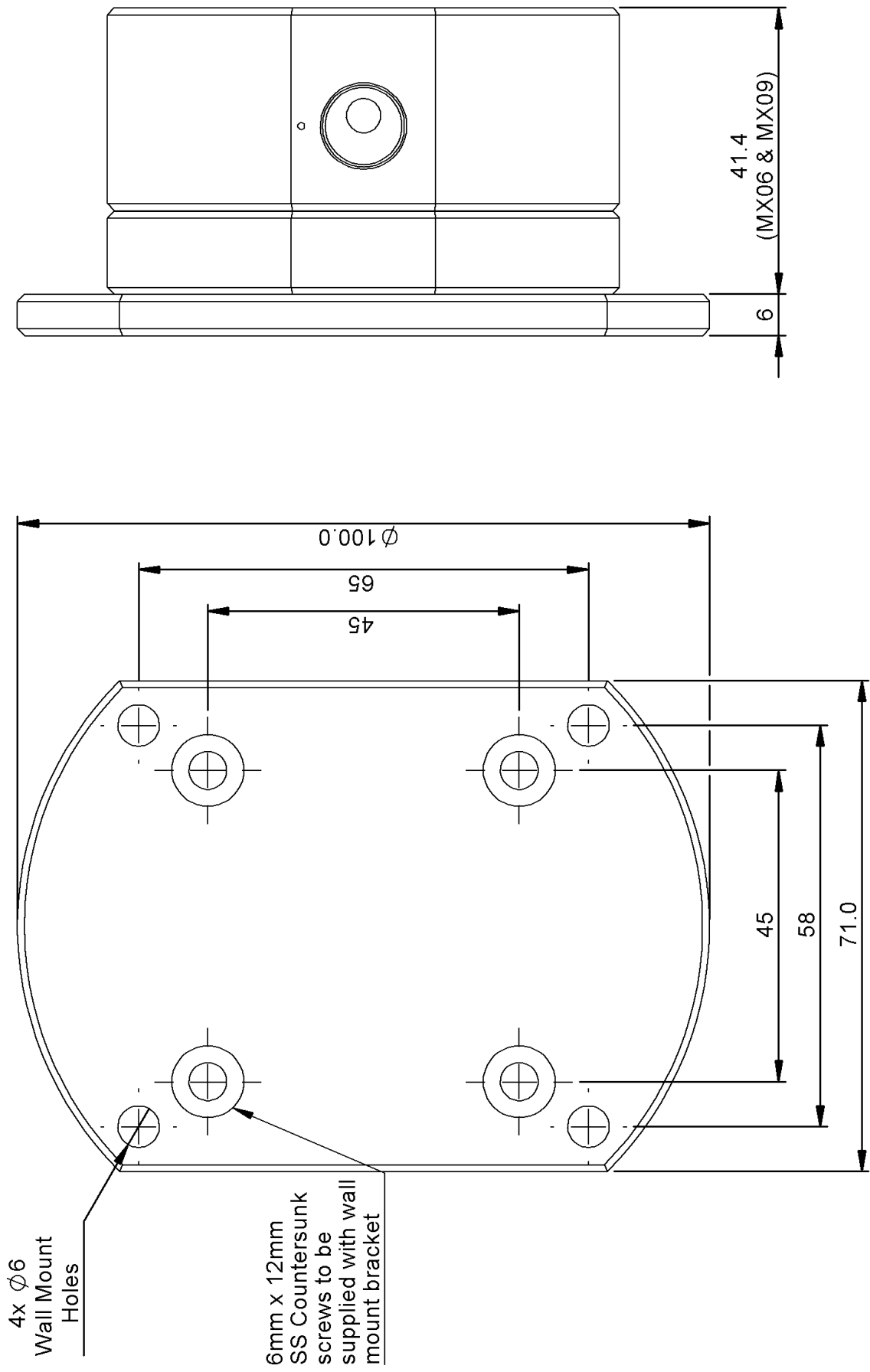

WEEE Directive - Waste Electrical and Electronic Equipment



The WEEE Directive requires the recycling of waste electrical and electronic equipment in the European Union.

Whilst the WEEE Directive does not apply to some of Macnaught's products, we support its policy and ask you to be aware of how to dispose of this product.

The crossed out wheeled bin symbol illustrated and found on our products signifies that this product should not be disposed of in general waste or landfill.

Please contact your local dealer national distributor or Macnaught Technical Services for information on product disposal.

EC Declaration of Conformity

In accordance with EN ISO 17050-2004

We: Macnaught Pty Ltd
Of: 41-47 Henderson St
Turrella NSW 2205
AUSTRALIA

Declare that:

Macnaught Flow Meters prefixed MX, F, CR, M or S in accordance with the following Directive;
2006/42/EC Machinery Directive (and its amending directives)

have been designed and manufactured to the following specifications;
EN ISO 12100:2010 Safety of Machinery

Declare that:

Macnaught Flow Meters prefixed MX, F, CR, M or S with flange nominal bores sizes 1” to 6” inclusive in accordance with the following Directive;
97/23/EC Pressure Equipment Directive (and its amending directives)

comply with the essential requirements of the Directive, classification Category 1 Group 1

Declare that:

Macnaught Flow Meter accessories prefixed DR, ER or PR as fitted to the Flow Meters or remotely mounted in accordance with the following Directive
2004/108/EC Electromagnetic Compatibility Directive (and its amending directives)

have been designed and manufactured to the following specifications;
EN61326-1:2006 Electromagnetic Compatibility – Electrical equipment for measurement, control and laboratory use.

I hereby declare that the equipment named above has been designed to comply with the relevant sections of the above referenced specifications.

The product complies with all essential requirements of the Directives.

This declaration is no longer valid if the unit is modified without our agreement.

Name: Steven Gavin
Position: Operations Director
Date: 21/06/2013
Done at: Macnaught Pty Ltd
41-49 Henderson St
Turrella NSW 2205,
AUSTRALIA



Issue 6
QA-CN5573
Issued by: Graham Wilson