

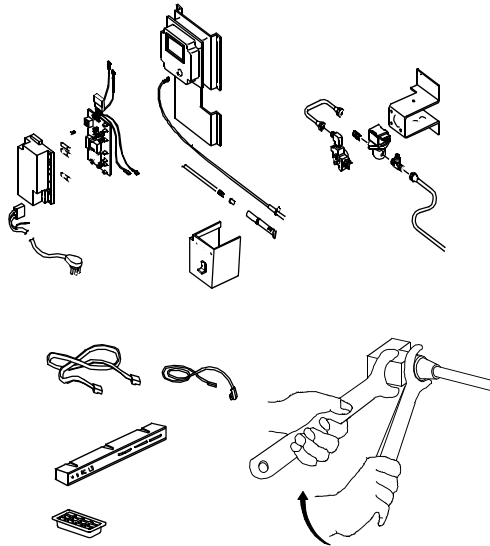

REPAIR GUIDE



MODELS

322

323

Part No. 618616
© NORCOLD 01/98

Table of Contents

Page

12-2	Specifications & Operating Limits
12-2	General Instructions
12-3	Electrical Connections
12-4	Description of Operation
12-5	Lighting & Start-Up Instructions
12-6	Preventative Maintenance
12-7	Troubleshooting
12-17	Removal & Replacement Procedure
12-22	Wiring Diagrams

General Information and Specification

Operating Limits - Models 322, 323

AC Mode: 132 VAC Max., 108 VAC Min.

DC Mode*: 15.4 VDC Max., 11.5 VDC Min.

Gas Mode: 11" W.C. Gas Supply \pm 0.5" W.C.
10.5" W.C. Min. Burner Pressure
(High Fire)

Models 322, 323 Ratings

LP Gas Mode: 640 BTU/Hr Input
11" W.C. Gas Supply
.010" Orifice (LP10)

AC Mode: 110 Volts AC, 140 Watts

DC Mode*: 12 Volts DC, 140 Watts

Current Draws - 322, 323

AC Heating Element - 1.3 amps @ 110 Volts AC
1.4 amps @ 120 Volts AC

DC Heating Element* - 11.7 amps @ 12 Volts DC
13.6 amps @ 14 Volts DC

Fuse Replacement Data

(Refrigerator Control Panel)

AC Circuit: 3 amp Type 3AG (1 1/4" x 1/4")
Norcold Part No.: 61654622

DC Circuit: 20 amp Type 3AG (1 1/4" x 1/4")
Norcold Part No.: 61440522

Gas Circuit: None

* 3-Way Models Only (Model 323)

General Instructions - Models 322, 323

The refrigerator described herein is designed and certified for built-in installations.

Model 323 is shipped from the factory as a 3-Way model to operate on propane gas, 120 volts AC or 12 volts DC.

Model 322 is shipped from the factory as a 2-Way unit to operate on propane gas or 120 volts AC electric.

To confirm that the installation is adequate, check for:

- Adequate ventilation (See Section 2 on "Ventilation Requirements").
- Both gas and electrical components installed and operating in a safe condition.

c. Adequate seal between refrigerator mounting flange and cut-out opening.

d. Installed on a solid floor (not on carpet) and se-

 **WARNING**

by screws through holes provided.
THIS REFRIGERATOR IS NOT INTENDED TO BE OPERATED AS A FREE STANDING UNIT (I.E. WHERE THE PRODUCTS OF COMBUSTION ARE NOT COMPLETELY SEALED OFF FROM THE LIVING AREA) OR INSTALLED IN SUCH A WAY AS TO CONFLICT WITH THESE INSTALLATION INSTRUCTIONS. UNAPPROVED INSTALLATIONS COULD RESULT IN SAFETY RISKS OR PERFORMANCE PROBLEMS.

c
u
r
e
d

Information About Electrical Connection

TABLE 1
12 Volt Supply Wiring & Fuse Size

	2-Way Models		3-Way Models	
	min. wire size	max. fuse size	min. wire size	max. fuse size
0-20'	18 AWG	6 Amp	12 AWG	20 Amp
over 20'	18 AWG	6 Amp	10 AWG	30 Amp

Electrical Connection - 120 Volts AC

The refrigerator is equipped with a three prong plug for protection against shock hazard and must be connected into a recognized three prong attachment receptacle. The free length of cord is 24". The cord must be routed so as not to come in contact with the burner cover, flue pipe or any other component that could damage the cord insulation.



DO NOT REMOVE (CUT) GROUNDING PRONG FROM THE REFRIGERATOR AC POWER CORD. REMOVAL OF THIS PRONG CAN RESULT IN A SEVERE ELECTRICAL SHOCK, AS WELL AS VOIDING THE REFRIGERATOR ELECTRICAL CERTIFICATION AND WARRANTY.

12 Volt DC Supply Connection

A 12 volt DC supply connection is only necessary if the refrigerator is a 3-Way model - either a Model 323 or a Model 322 with the DC option added by a dealer. Both the AC and GAS modes operate without a need for 12 volts.

If the 12 volt connection is required, the negative connection from the battery is connected to terminal 5 on the terminal block and the +12 volt from the battery is connected to an in-line fused wire which, in turn is connected to terminal 6. See wiring diagram at the end of this section. Both negative and positive supply wires require 1/4" female quick connect terminals.

See TABLE 1 for supply wire and fuse sizing. The wire size is determined by the DC load (heater draw) and the distance the current must travel from the battery. Should the wire size be too small, a resulting voltage drop reduces the heater wattage and the cooling capacity in the DC mode. The refrigerator is designed to operate at full cooling capacity, unlike other RV refrigerators which operate at a reduced capacity to conserve battery drainage. The DC heating element has a continuous current rating of 11.6 amps @ 12VDC.

Operation

The controls are designed so that each mode of operation is independent of the other. All electricity could be cut off and the refrigerator still operate in the GAS mode. 12 Volts is not necessary to operate the control circuit.

Gas Mode

The GAS mode uses a thermocouple system to produce a self-generating power (milli-volts). The Thermocouple, when heated by the burner flame, produces enough milli-volts to hold the safety valve open. A loss of flame de-energizes the safety valve and shuts the propane gas down.

An Interrupter device is coupled in series with the thermocouple so that the milli-amps cannot flow to the Safety Valve (part of the Control Valve) until the Interrupter contacts are shunted (jumpered). The shunt is provided by the Selector switch when it is switched to GAS mode.

The Selector switch not only serves as a mode selector but also as an interlock between modes so that two sources of power cannot be energized simultaneously.

The GAS mode utilizes an adjustable GAS control. The control can be manually adjusted to meter the fixed amount of propane gas to the burner thereby acting as a temperature control to maintain cabinet temperature.

Important: Unlike an automatic gas control, this control does not cycle the flame from high fire to low fire as with other types of RV refrigerators. If the cooling load changes, the GAS control must be manually adjusted to maintain the same temperature.

The gas ignition method uses a piezo spark ignitor - requiring a manual ignition of the burner. See the Lighting Instructions.

Electric Modes

The AC mode, and DC mode in the case of the 3-Way model, is thermostatically controlled by a non-adjustable thermostat. The Thermostat has a capillary sensor attached to the cooling fin. The electric heater (AC or DC) will cycle in response to the fin temperature to maintain the cabinet temperature.

Lighting and Start-Up Instructions



DO NOT HOLD GAS VALVE (D) IN MORE THAN 30 SECONDS, IF FLAME IS NOT INDICATED WITHIN THIS TIME, TURN GAS TO OFF, WAIT 2 MINUTES AND RETRY. CONTINUING TO HOLD GAS VALVE IN WILL CAUSE GAS BUILD-UP IN THE BURNER AREA AND CAN RESULT IN AN EXPLOSION WHICH CAN CAUSE PERSONAL INJURY OR DEATH.

Lighting Instructions - Gas Operation

1. Open the lower vent door on the outside rear of the vehicle to gain access to the rear of the refrigerator. Open window on front side of Burner Box to view the burner shown in Figure 8.
2. Set the Energy Selector Switch (A) to the GAS position.
3. Set the Gas Control Selector (D) to the HIGH COOL position.
4. Ensure that the manual shut-off valve is open. See location in Figure 1.
5. While pushing the Gas Control Selector switch (D) in, press the spark ignitor push-button (B) in, several times in rapid succession (A click should be heard each time it is depressed.). The burner should light; however, continue to hold the Gas Control Selector (D) in for another 15 seconds before releasing.
6. Verify that the flame remains lit by looking at the burner through the burner box window in Figure 8.
7. Adjust the Gas Control Selector (D) to the desired cooling setting. Close viewing window on Burner Box.

Start-Up Instructions - AC Electric Operation

1. Verify that 120 volts AC is available to the refrigerator and that the AC fuse (C) in the control bracket is operational.

2. Set the Energy Selector Switch (A) to the AC position and verify that the Gas Control Selector (D) is in the OFF position.
3. No other action is required since a non-adjustable thermostat is provided to prevent food from freezing in the electric modes.

Start-Up Instructions - DC Electric Operation (3-Way)

1. Verify that 12 volts DC is available to the refrigerator and that the in-line DC fuse in the DC heater wire assembly is operational.
2. Set the Energy Selector Switch (A) to the DC position and verify that the Gas Control Selector (D) is in the OFF position.
3. No other action is required since a non-adjustable thermostat is provided to prevent food freezing in the electric modes.

Shut-Down Instructions - All Models

1. Set the Gas Control (D) to OFF position.
2. Set the Energy Selector Switch (A) to GAS position.

NOTE: The Gas Control and Energy Selector must be switched to the above positions to completely shut down the refrigerator.

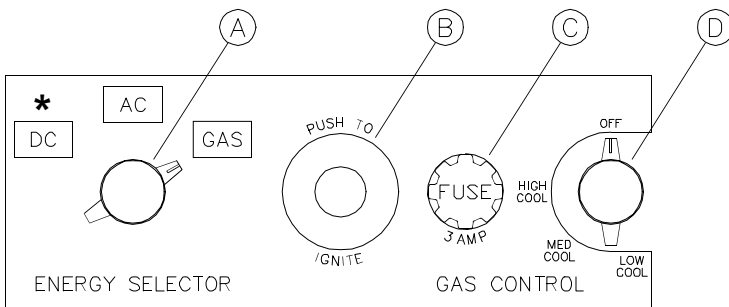

*323 models & 322 model with DC add-on

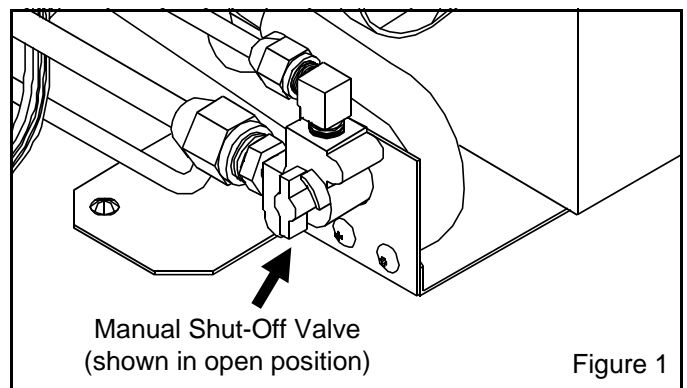

Figure 1

Preventative Maintenance

Maintenance Check List

A safety and performance check should be made annually. The schedule should include at least the following:

- a. Leak test the gas lines.
- b. Check combustion seal; repair or replace, if necessary (Visual check without removing the refrigerator.).
- c. Inspect or clean the burner or burner orifice.
- d. Check/adjust the electrode spark gap.
- e. Insure the Thermocouple tip is clean and secure in the burner bracket.
- f. Check/adjust AC and DC voltages and gas supply pressure.
- g. Check the Flame Failure Safety Device (See procedure below).
- h. Insure that the area around the burner and controls is free of debris, oily rags, etc..
- i. Inspect the controls, piping and wiring to insure that they are in good condition.

THESE MAINTENANCE PROCEDURES MUST BE PERFORMED BY A QUALIFIED SERVICE PERSON. NORCOLD CANNOT ACCEPT RESPONSIBILITY FOR REPAIRS, ADJUSTMENT, OR MAINTENANCE PERFORMED BY OTHER THAN A QUALIFIED DEALER OR SERVICE CENTER.

Check-Out of Flame Failure Safety Device

1. To verify proper operation of the flame failure safety device, first start the system in the gas mode and verify the presence of a steady flame.
2. Turn off the gas at the manual gas input shutoff valve.
3. The flame will go out and within three minutes, the flame failure safety device should automatically close (A sharp click should be heard as this device closes.).
4. Turn the gas back on at the manual gas input shutoff valve.
5. Attempt to relight the burner by pressing the spark ignitor push-button rapidly in succession but without pressing the Gas Control Selector in.
6. If the burner cannot be re-ignited without holding the Gas Control Selector in, the flame failure safety device has operated correctly.

The service facility should review with the refrigerator owner the preventative maintenance steps which can be performed by the user. The check list is printed in the Installation and Operating Instructions and repeated here.

Owner's Check List

1. Keep the food compartment clean (See section on Cleaning the Refrigerator in the Installation and Operating Instructions).
2. Check for frost build-up (See section on Defrosting in the Installation and Operating Instructions).
3. Check for proper draining of the fins in the fresh food compartment.
4. Insure that the food compartment door is sealing properly (See section on Door Sealing in the Installation and Operating Instructions).
5. Be alert to noticeable changes in cooling performance, either overcooling or poor cooling. If this happens without changes in other factors such as weather or resetting of thermostat, contact your dealer or Service Center.
6. Insure that your LP gas supply is Propane, not other types such as Butane or Butane mixtures.
7. Check the flame appearance during operation in the GAS mode (See section on Gas Flame Appearance in the Installation and Operating Instructions).
8. Inspect the floor at the rear of refrigerator (Look through intake vent from outside of coach). If water appears frequently, contact your dealer or Service Center.
9. Insure the ventilation space behind the refrigerator (the area from the bottom intake vent, up the back of the refrigerator and to the top exhaust vent) is clear of obstructions (insulation, supports, bird or squirrel nests, etc.).
10. Insure that the area directly behind the refrigerator is not being used for storage, particularly for storage of combustible material.

Troubleshooting

Failure of Refrigeration

Failure of refrigeration does not necessarily indicate that the cooling system is defective. Other factors governing its operation must be checked.

If the refrigerator has been operating on gas and a loss of cooling is noted, convert the refrigerator to electric operation, AC power (See "Start-Up Instructions - AC Electric Operation"). If the refrigerator has been operating on electric, switch it to gas operation. This will determine if a component failure in the electric or gas controls is causing the cooling fault.

After the refrigerator has been converted from one power source to the other (gas to electric, or electric to gas) allow several hours to assure the unit is cycling properly. At the end of the period the fins should start to cool providing the following items have been checked out thoroughly.

1. The refrigerator is level in each direction.
2. The controls have been properly set for the power source utilized.
3. The power source is at the correct 10.5 - 11 inches water column for gas at the refrigerator's pressure tap (Figure 2) and 108-132 volts AC for electric or 11.5 to 15.4 volts DC.
4. The upper and lower vents are not obstructed restricting ventilation.

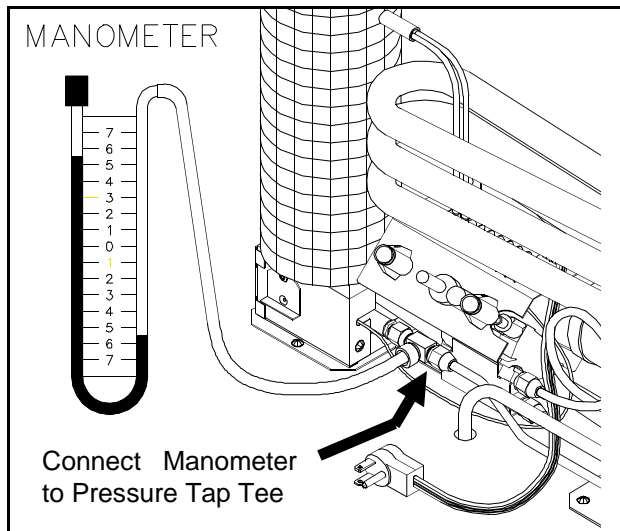

Figure 2

If no cooling is evident after a reasonable time period, the cause of failure may be due to a blocked system. This blockage is caused when the refrigerator is operated for extended periods in an off-level condition beyond the range of 3 degrees left to right

and 6 degrees front to back. This does not mean the system is non-functional, but requires the refrigerator to be removed from the vehicle and placed on its right side when facing the front for a minimum of one hour. This will allow the ammonia and water to mix with one another which is necessary in the absorption system operation.

Once the system has been relieved of its blockage, operation on AC should once again be initiated for a reasonable time period to determine if the cooling process has been restored. If after this period the fins have no indication of cooling on either gas or electric the refrigerator will have to be replaced.

Refrigerator Not Cooling on AC



USE EXTREME CAUTION WHEN WORKING ON THE AC ELECTRICAL COMPONENTS OF THE REFRIGERATOR. BEFORE REPLACING ANY ELECTRICAL COMPONENT, DISCONNECT THE AC POWER SOURCE TO THE REFRIGERATOR. ELECTRICAL CURRENT CAN CAUSE SEVERE ELECTRICAL SHOCK OR DEATH.

If the refrigerator is not cooling with the Selector switch in the AC mode - yet cools in the gas mode - the AC heater is probably not energized. Check the following:

1. Check for 110 volts to the heater at AC Terminals 1 and 2 (See Figure 3 for location).

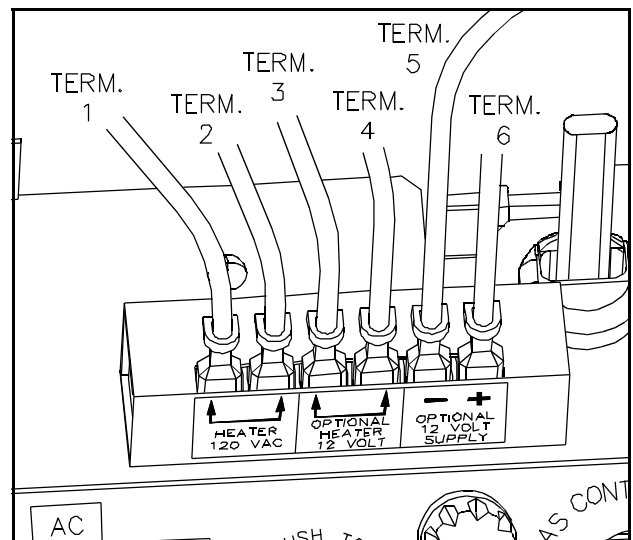

Figure 3 - Identification Terminal Block Connections

If there is no reading, the possibilities are a) AC supply not connected, b) 3 Amp fuse blown, c) wiring connections, or d) defective switch or thermostat. Proceed to Step 2.

If voltage is measured (108-132 volts), then the heater or the wiring to the heater is defective or the heater is not positioned properly in the heater well. Proceed to the Continuity test in Step 4.

2. If no heater voltage is measured, disconnect the AC supply cord and measure the voltage at the AC receptacle. If no reading, determine why the power is not connected. If voltage is present, check fuse in next step.
3. Without reconnecting the AC supply cord, check condition of the 3 Amp fuse (should be 0 Ohms using an Ohmmeter set at lowest scale); replace if necessary and repeat Step 1 to insure there is no secondary problem. If fuse blows a second time, go to Step 4 since it indicates either a shorted heater or a grounding fault.

⚠ WARNING

NEVER OVER FUSE A CIRCUIT. REPLACE BLOWN FUSE WITH EXACT REPLACEMENT INDICATED BY NORCOLD. OVER FUSING OF A CIRCUIT CAN RESULT IN A FIRE.

If the fuse is good (and still no voltage to the heater), the problem is an open circuit either in the Control Assembly or the interconnecting wiring. Using the wiring diagram and Figure 4 as reference, check the wiring for loose connections or incorrect connections. If a check of wiring proves OK, either the Thermostat or the Selector Switch has an open circuit. Isolate the open circuit as follows:

- a. With the AC cord disconnected, unfasten the Control Assembly and lay back to view the control wiring - See the first four steps of the selector switch removal procedure on page 12-20. Without removing any wires, place a jumper across terminals W1 & W2 as illustrated in Figure 5. Make sure the jumper is making contact with the copper wire of metal terminal.

Note: Access to the terminals can be gained by probing through the end of the Quick Connectors as shown in the illustrations.

If the AC heater is now energized when power is applied, replace the Thermostat. If not, remove jumper and go to (b).

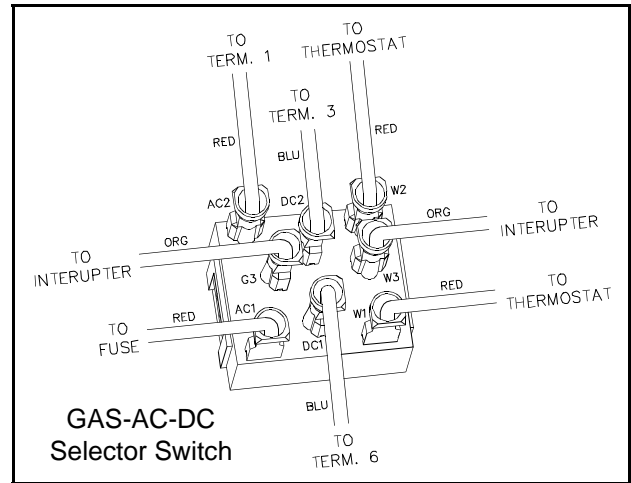

Figure 4 - Wiring Connections to Selector Switch

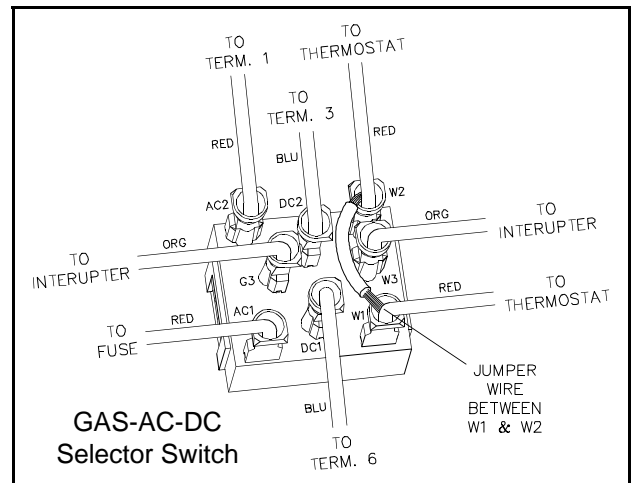

Figure 5 - Thermostat Jumper Connection

- b. With the AC cord disconnected, lay back the Control panel as described in Step (a) and place one jumper from AC2 to W2 and another jumper from AC1 to W1 according to Figure 6. If AC is now energized when power is applied, replace the Selector Switch per replacement procedure on page 12-20.

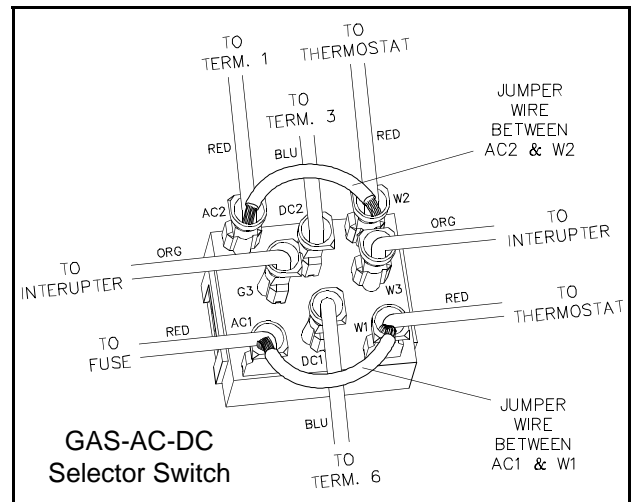

Figure 6 - Selector Switch - Jumpers on AC Section

4. **Ground Fault Test:** With the Selector switch still in the AC position and the AC Supply cord disconnected, use an Ohmmeter (set on highest scale) to measure resistance between the HOT and GROUND prongs, as illustrated in Figure 7. Read the Ohmmeter and refer to TABLE 2.

Continuity Test: With the Selector switch still in the AC position and the AC cord disconnected, use an Ohmmeter to measure resistance between the HOT and NEUTRAL prongs of the AC cord connector, as in Figure 7. Read the Ohmmeter and refer to TABLE 2.

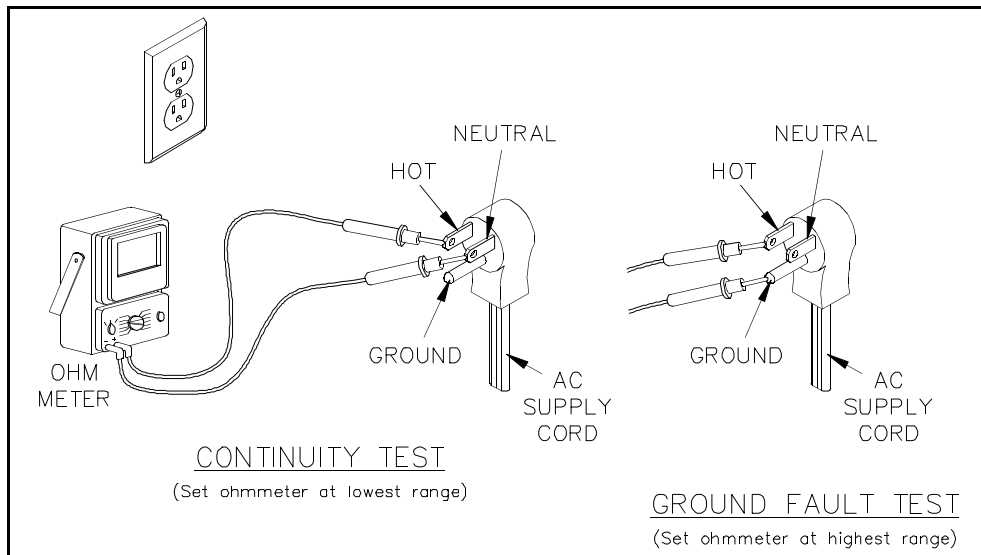

Figure 7 - Continuity Ground Fault Test - AC

TABLE 2 Ground Fault/Continuity Check

Test Points on AC Cord Prongs (See Figure 7)	Ohmmeter Reading	Indication	Action
Hot Terminal & Prong	0 Ohms (dead short)	Indicates a grounding fault	Go to Step 5
Hot Terminal & Prong	Open Circuit	Normal condition	Possibility of ground fault is eliminated
Hot & Neutral Terminals	76 - 85 Ohms*	Heater is good	Go to Step 7
Hot & Neutral Terminals	above 85 Ohms or below 76 Ohms	Heater is out of tolerance	Replace heater
Hot & Neutral Terminals	0 Ohms (dead short)	Indicates a short in the AC circuit	Go to Step 5
Hot & Neutral Terminals	Open Circuit (no reading)	Indicates an open in the AC circuit	Go to Step 6

* If the heater is hot when the measurement is taken, the correct resistance range is 82-91 Ohms.

5. If the Ground Fault or the Continuity Test measures a short (0 Ohms), this causes the 3 Amp fuse to blow. Repeat the test where 0 Ohms was measured but this time with the AC heater disconnected (Reason: to determine whether the short is in the heater or the controls).

the first four steps of the selector switch removal procedure on page 12-20. Carefully inspect all connections for erroneous grounding of electrical terminals. If nothing found, replace the Control Assembly. See page 12-18 for replacement procedure.

a. If the Ohmmeter still shows a short (0 Ohms), the control panel has a short. Remove the Control Assembly and lay back according to

b. If the Ohmmeter now shows an open circuit, the short is in the heater and must be replaced.

6. If the Continuity Test indicated in TABLE 2 measures an open, remove the heater leads at Terminals 1 & 2 and install a jumper across terminals 1 & 2 (See Figure 3 for location). Repeat the Continuity Check.

If after installing the jumper, the Ohmmeter now shows a short, the heater has the open circuit and must be replaced. Remove jumper from terminals 1 & 2.

If the Ohmmeter still shows an open, there is an open circuit in the control panel (make sure the Selector switch is still in the AC position and the fuse is good). The control assembly should be detached and layed back according to the first four steps of the selector switch removal procedure on page 12-20. Make sure all the wiring is correct according to the wiring diagrams and Figure 4. If wiring is proper, remove the jumper from terminal 1 & 2 and isolate the open in the Control Assembly as follows:

- a. With the AC cord disconnected, unfasten the Control Assembly and lay back to view the control wiring as described above. Without removing any wires, place a jumper across terminals W1 & W2 as illustrated in Figure 5.

Note: Access to the terminals can be gained by probing through the end of the Quick Connectors as shown in the illustrations.

If the AC heater is now energized when power is applied, replace the Thermostat. If not, remove jumper and go to (b.) below.

- b. With the AC cord disconnected, lay back the Control panel as described above and place one jumper from AC2 to W2 and another jumper from AC1 to W1 according to Figure 6. If AC is now energized when power is applied, replace the Selector Switch per replacement procedure on page 12-20.
7. If the continuity test in Step 4 indicates normal heater ohms (76-85), then the problem is not in the electrical circuit. Make sure the supply voltage is within 108 to 132 volts range and check heater position to insure it is securely installed in its well.

Poor Cooling in AC Mode

If the refrigerator is cooling poorly in AC yet satisfactory in the GAS mode, the problem could be one of the following:

- a. Low voltage to heater (or extremely high voltage).
 - b. Heater not within wattage specification
 - c. Heater not secure in heater well
1. Check for 110 volts to the heater at Terminals 1 and 2 (See Figure 3 for location). The voltage range limitation is 108 - 132 Volts AC. Note: Do not disconnect the heater when this measurement is taken. If voltage reading is acceptable, go to Step 2.
 2. Disconnect the AC supply cord and use an Ohmmeter to measure the HOT and NEUTRAL prongs of the AC connector, as in Figure 7. The measurement must be between 76 Ohms and 85 Ohms (or, if the heater is still hot, between 82 ohms and 91 ohms). Replace the heater if outside these stated limits.
 3. If measurements in Steps 1 & 2 are acceptable, the problem is not in the electrical circuit. Inspect the heater installation to insure the heater is inserted to the "stop" bead and there is no physical damage.

Refrigerator Not Functioning in Gas Mode



USE EXTREME CAUTION WHEN WORKING ON OR NEAR A PROPANE GAS SYSTEM. DO NOT SMOKE NEAR A PROPANE GAS SYSTEM. DO NOT USE AN OPEN FLAME TO CHECK THE PROPANE GAS SYSTEM FOR LEAKS. A LOOSE PROPANE SUPPLY LINE CONNECTION ALLOWS GAS VAPORS TO ESCAPE. IF YOU CAN SMELL FUMES, YOU HAVE HALF THE INGREDIENTS FOR AN EXPLOSION. AN EXPLOSION CAN RESULT IN SEVERE PERSONAL INJURY OR DEATH.

Continued on next page.

VISUAL OBSERVATIONS

- * Check thermocouple position in flame. Refer to Figure 8. The Thermocouple should be seated securely in its bracket with the sensing end extended over the flame, as shown. Lack of proper Thermocouple position can cause flame blowout symptoms or failure to hold the flame when trying to ignite the burner.

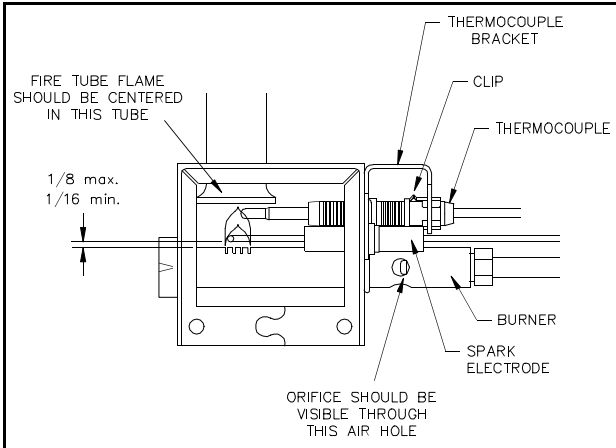

Figure 8 - Burner Assembly

- * Check thermocouple connection to the Interrupter and the Interrupter connection to the Gas control insuring connections are tight. The same flame failures as stated above can result from loose connections.

CAUTION

DO NOT OVER-TIGHTEN THE CONNECTIONS ON EITHER SIDE OF THE INTERRUPTER. THE CORRECT PROCEDURE FOR BOTH CONNECTIONS IS TO TURN THE CONNECTOR UNTIL IT IS FINGER TIGHT; THEN TIGHTEN IT A QUARTER TURN MORE.

- * Check the orange wires from the Interrupter switch to the Selector switch to insure good connections from the Interrupter terminals to G3 & W3 on the Selector switch. Refer to Figures 9 and 10.

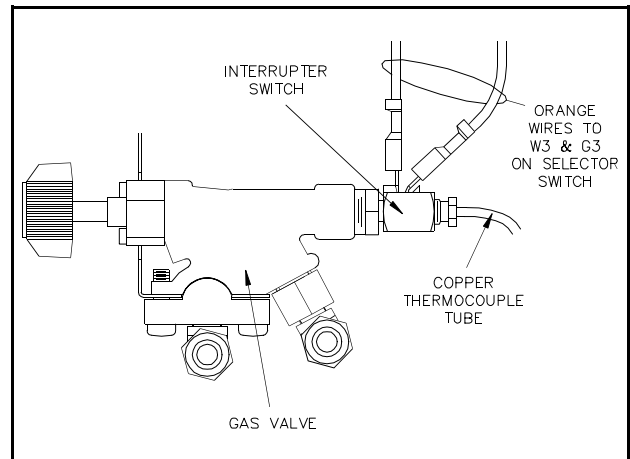

Figure 9 - View of Interrupter Switch

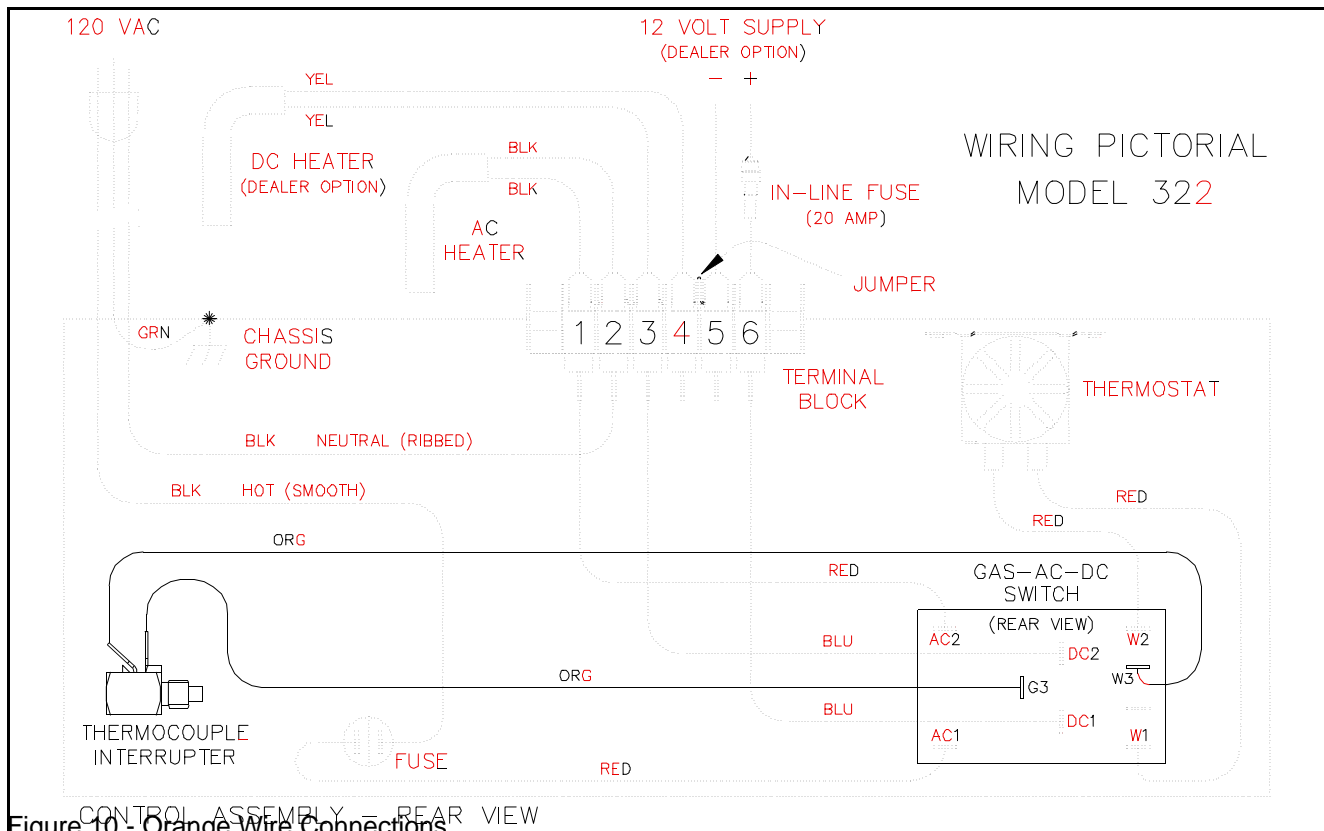

Figure 10 - Orange Wire Connections

- * Check to insure the main gas pressure is set at 11" W.C. with only the refrigerator running. Then check with all other gas appliances operating. This check assures the main tank regulator is properly functioning. Make sure the customer is using propane, not a mixture of Butane, etc.
- * Check the flame appearance. Refer to Figure 11. The flame should emerge from all four burner slots with a steady blue color without yellow or smoky tips.

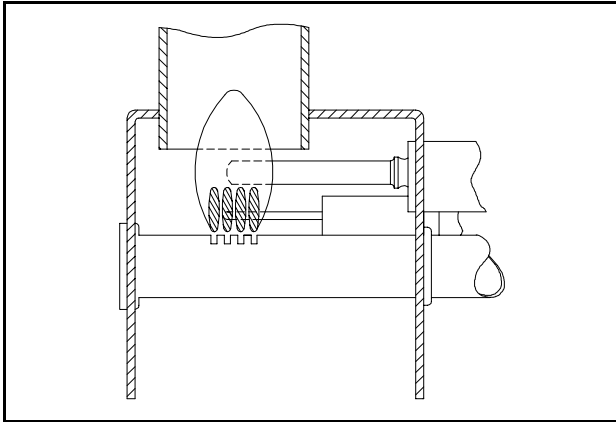

Figure 11

- * The flame envelope should be centered into the fire tube (See Figure 11). If the envelope hits on the side of the fire tube, a noticeable decrease in cooling could be observed. This condition would be caused by physical damage to the burner or fire tube.
- * If extremely poor cooling is observed on Gas mode only and all of the above observations seem normal, make sure the flame spreader is properly placed in the fire tube. See Figure 12 for proper position.

If the visual observations listed above do not identify a cooling problem in the Gas mode, perform the following checks:

1. Insure that the Selector switch is set for gas operation and that the gas is turned on at the tank, and that the manual shut-off valve is in the ON position.
2. Connect a manometer to the pressure tap tee as indicated by Figure 2.
3. Depress and rotate the gas control knob counterclockwise to the max. cool position. You should show 10.5" to 11" W.C. NOTE: Keep the control knob depressed.
4. Rotate the knob to the min. cool position the manometer should show 8.5" W.C. \pm 0.5" W.C.

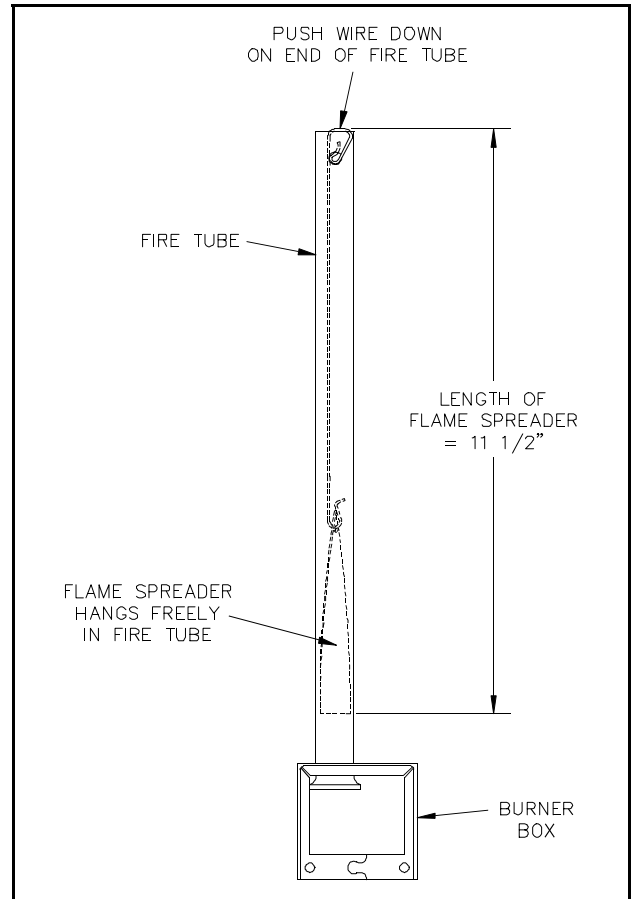

Figure 12 - Flame Spreader Position

5. If the pressures are not as indicated in Step 3 and 4, check the following:

- Recheck the main gas pressure to the refrigerator is set at 10.5" to 11" W.C.
- Inspect the filter located in the inlet side of the manual Gas Valve (Figure 13) to confirm that it has not become dirty/plugged from contaminants. If in doubt, replace the filter.
- Inspect the burner orifice to confirm it is the correct size (LP10) and that it is clean.

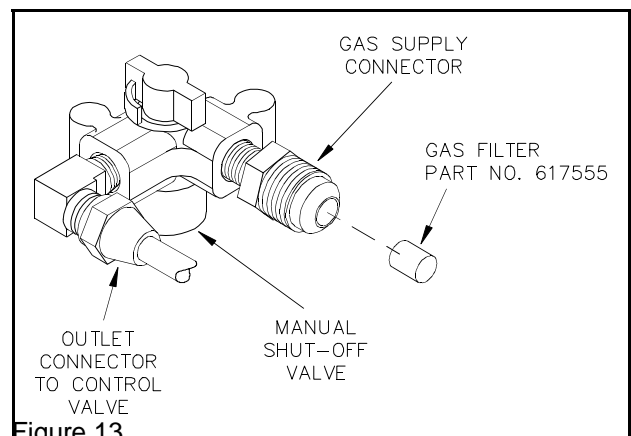

Figure 13

- If the above inspections do not show reasons for incorrect pressure, the problem is in the Control Valve. Replace the Control Valve referring to page 12-18 for replacement procedure.

If the refrigerator fails to light on GAS:

1. If the piezo lighter does not supply sparks to the burner when depressed, check for correct adjustment of the electrode. It should be 1/8" max., 1/16" min. above the burner. See Figure 8.

If the Electrode position is correct and there is still no spark when rapidly depressing the red piezo button, inspect the ignitor wire from the Electrode to the Piezo lighter to insure good connections and that it is not grounded through skinned insulation, etc.

If the Piezo still does not produce sparks, the Piezo Ignitor must be replaced. See page 12-19 for replacement procedure.

2. If the flame does not hold the safety valve open (flame goes out when Gas Control is released) in the GAS mode, check that the thermocouple is tight and that the gas pressure is correct at 11" W.C..



DO NOT OVER-TIGHTEN THE CONNECTION ON EITHER SIDE OF THE INTERRUPTER. THE CORRECT PROCEDURE FOR BOTH CONNECTIONS IS TO TURN THE CONNECTOR UNTIL IT IS FINGER TIGHT; THEN TIGHTEN IT A QUARTER TURN MORE.

The tip of the Thermocouple must not touch the metal fire tube or any metal part; this condition could prevent the flame from locking in.

If Thermocouple is correctly positioned and the safety valve still does not hold the flame, use the following procedure to isolate the problem:

Make sure that the Energy Selector is set at GAS and the Gas Control is set at HIGH COOL. With a digital multimeter set to read milli-volts, connect probe lead (A) to one of the Interrupter terminals as illustrated in Figure 14 (do not remove the orange wires from the Interrupter terminals although you may need to raise them slightly to allow the probe to touch the terminal). Connect the other probe lead (B) to the copper thermocouple tubing. Ignite and maintain a flame at the burner by continually holding in the Gas Control knob. Observe the milli-volt reading. Then move probe A to the other terminal and observe the milli-volt reading. The problem can be isolated as follows:

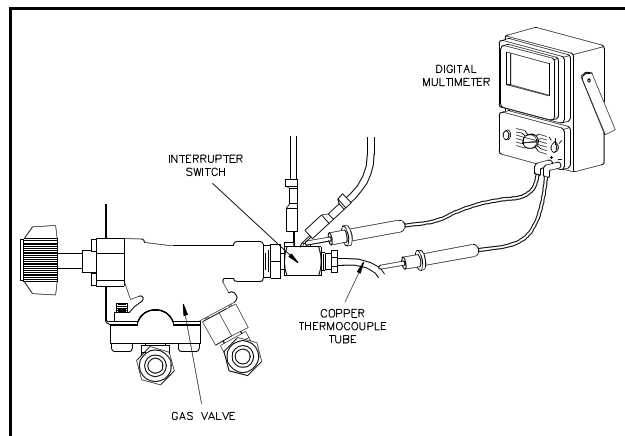

Figure 14 - Measuring Thermocouple milli-volts

Thermocouple Troubleshooting Table

Milli-Volt Reading	Diagnosis
4-19 milli-volts read at both Interrupter terminals	This is a normal reading indicating problem is mechanical, not electrical. Thermocouple functioning properly. Defective Gas Control Valve; replace per procedure on page 12-18.
0 milli-volts read at both Interrupter terminals	Defective Thermocouple; replace per procedure on page 12-19.
High milli-volt reading (20-30) on one Interrupter terminal 0 milli-volts on other	Thermocouple OK if orange wires properly connected to W3 & G3 from the Interrupter, replace the Control Valve and Interrupter per procedure on page 12-18.
High milli-volts (20-30) on both Interrupter terminals	Defective Gas Control Valve; replace per procedure on page 12-18.

Refrigerator Not Cooling on DC

If the refrigerator is not cooling with the Selector switch in the DC mode - yet cools in the other modes - the DC heater is probably not energized. Check the following:

1. Check for 12 volts to the heater at DC heater Terminals 3 (+) and 4 (-). See Figure 3 for location. If there is no reading, the possibilities are a) DC supply not connected, b) 20 Amp fuse blown, c) wiring connections, or d) defective Selector switch. Proceed to Step 2.

If voltage is measured (10.5-15.4 volts), then the heater or the wiring to the heater is defective or the heater is not positioned properly in the heater well. Proceed to the Continuity Test in Step 4.

2. If no heater voltage is measured, check condition of the 20 Amp fuse (should be 0 Ohms using an Ohmmeter set at lowest scale); replace if necessary and repeat Step 1 to insure there is no secondary problem. If fuse blows a second time, go to Step 4 since it indicates either a



shorted heater or a grounding fault. NEVER OVER FUSE A CIRCUIT. REPLACE BLOWN FUSE WITH EXACT REPLACEMENT INDICATED BY NORCOLD. OVER FUSING OF A CIRCUIT CAN RESULT IN A FIRE.

3. If the fuse is good, reinstall fuse and check the Supply voltage at Terminal 5 (-) and 6 (+). See Figure 3 for location. If no reading or if the voltage is outside the limits of 10.5 Volts min. and 15.4 Volts max., correct the power source. If there is still no voltage at the heater terminals (Terminals 3 & 4), the problem is an open circuit either in the Control assembly or the interconnecting wiring. Using the wiring diagram as reference, check the wiring for loose connections or incorrect connections. If a check of wiring proves OK, the open circuit is either in the Thermostat or Selector Switch. Isolate the problem as follows:

- a. With the AC and DC power disconnected, unfasten the Control Assembly and lay back to view the control wiring - per removal procedure on page 12-18. Without removing any wires, place a jumper across terminals W1 & W2 as illustrated in Figure 5.

Note: Access to the terminals can be gained by

probing through the end of the Quick Connectors as shown in the illustrations.

If the DC heater is now energized when power is applied, replace the Thermostat. If not, remove jumper and go to (b.) below.

- b. With the AC and DC power disconnected, lay back the Control panel as described in Step (a) and place one jumper from DC2 to W2 and another jumper from DC1 to W1 according to Figure 15. If DC is now energized when power is applied, replace the Selector Switch

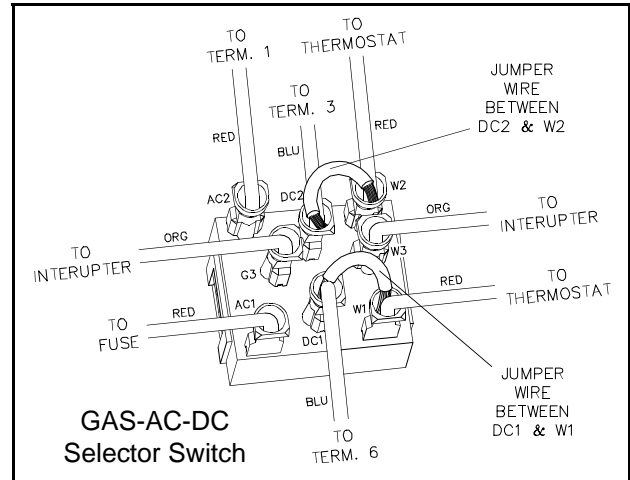

Figure 15 - Selector Switch with Jumper on DC Section

- per replacement procedure on page 12-20.
4. Ground Fault Test: With the Selector switch still in the DC position, disconnect the DC Supply at Terminals 5 and 6. Use an Ohmmeter (set on highest scale) to measure resistance between Terminal 6 and chassis ground (metal panel will work), as illustrated in Figure 16. Read the Ohmmeter and refer to TABLE 3 on page 12-16.

Continuity Test: With the Selector switch still in the DC position and the DC Supply disconnected at Terminals 5 & 6, use an Ohmmeter to measure resistance between Terminals 5 & 6, as in Figure 17. Read the Ohmmeter and refer to TABLE 3 on page 12-16.

5. If the Ground Fault or the Continuity Test measures a short (0 Ohms), this causes the 20 Amp fuse to blow. Repeat the test where 0 Ohms was measured but this time with the DC heater disconnected (Reason: to determine whether the short is in the heater or the controls).

If the Ohmmeter still shows a short (0 Ohms), the control assembly has a short and must be replaced. See page 12-18 for replacement procedure.

If the Ohmmeter now shows an open circuit, the

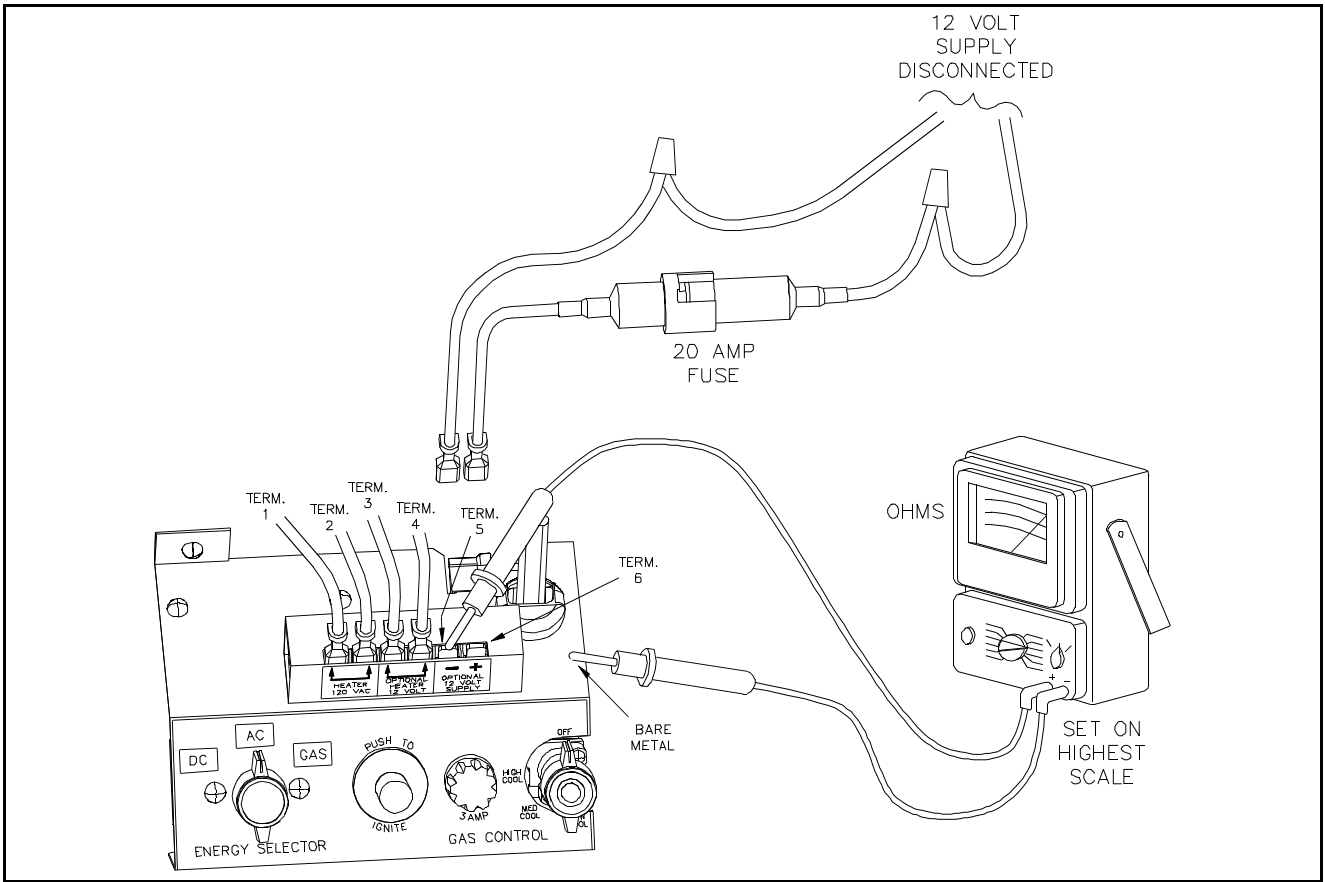

Figure 16 - Ground Fault Test - DC

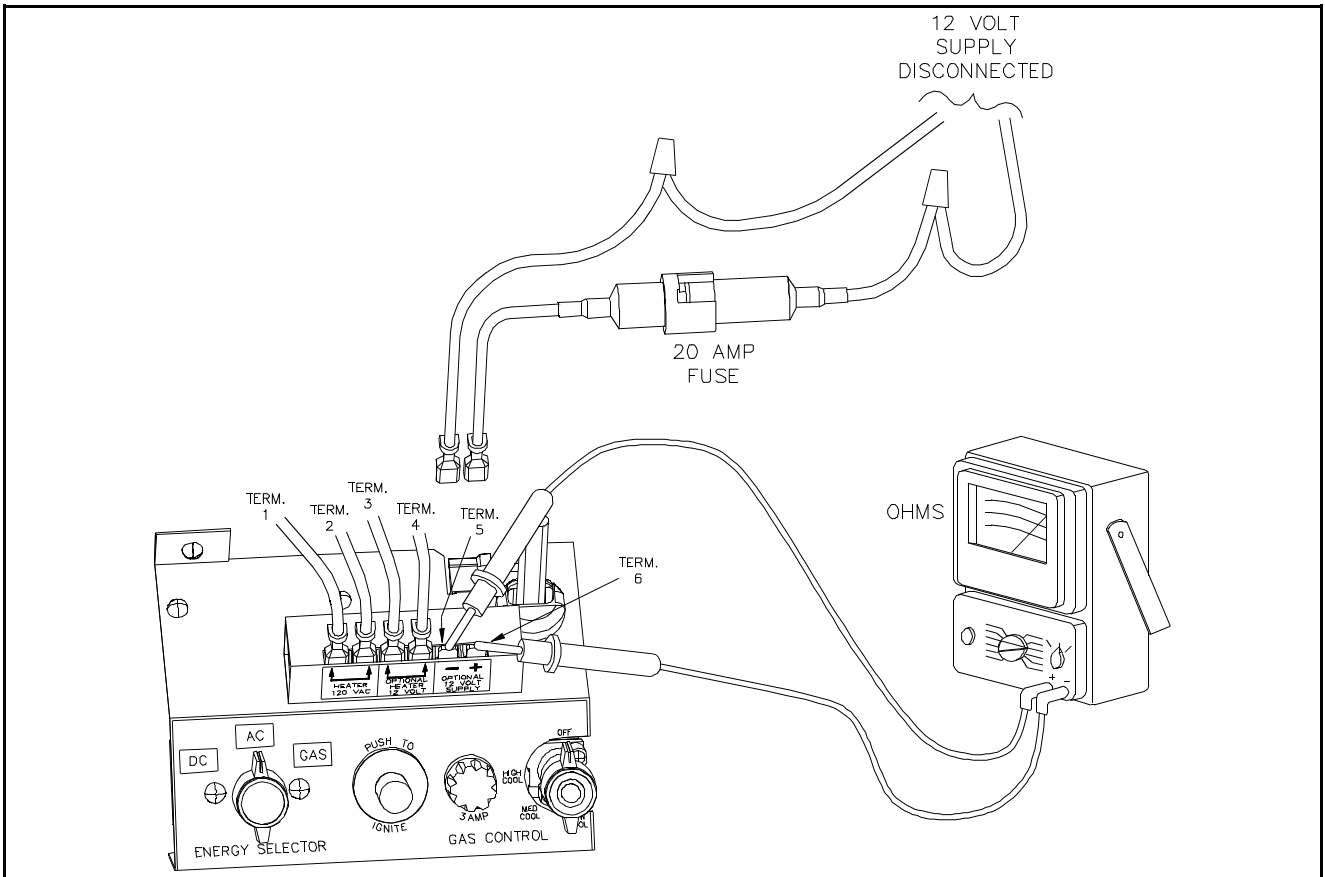

Figure 17 - Continuity Test - DC

TABLE 3
DC Ground Fault/Continuity Check

Test Points	Ohmmeter Reading	Indication	Action
Terminal 6 & Chassis See Figure 16	0 Ohms (dead short)	Indicates a grounding fault	Go to Step 5
Terminal 6 & Chassis See Figure 16	Open Circuit	Normal condition	Possibility of ground fault is eliminated
Terminal 5 & 6 See Figure 17	1.21 - 1.37 Ohms*	Heater is good	Go to Step 7
Terminals 5 & 6 See Figure 17	above 1.37 Ohms or below 1.21 ohms	Heater is out of tolerance	Replace heater per replacement procedure on page 12-17
Terminals 5 & 6 See Figure 17	0 Ohms (dead short)	Indicates a short in the AC circuit	Go to Step 5
Terminals 5 & 6 See Figure 17	Open Circuit (no reading)	Indicates an open in the AC circuit	Go to Step 6

* If the heater is hot when the measurement is taken, the correct resistance range is 1.3 - 1.47 Ohms.

short is in the heater and must be replaced.

6. If the Continuity Test indicated in TABLE 3 measures an open, remove the heater leads at Terminals 3 & 4 and install a jumper across terminals 3 & 4 (See Figure 17 for location). Repeat the Continuity Check.

If after installing the jumper, the Ohmmeter now shows a short, the heater has the open circuit and must be replaced. Remove jumper from terminals 3 & 4.

If the Ohmmeter still shows an open, there is an open circuit in the control panel (make sure the Selector switch is still in the DC position). The control assembly should be pulled out to make sure all the wiring is correct. See page 12-18 for removal procedure and wiring diagrams to aide in tracing the wiring connections. Remove jumper from terminal 3 & 4. If a check of wiring proves OK, either the Thermostat or the Selector is has an open circuit. Isolate the open circuit as follows:

- a. With the AC and DC power disconnected, unfasten the Control Assembly and lay back to view the control wiring - per removal procedure

on page 12-18. Without removing any wires, place a jumper across terminals W1 & W2 as illustrated in Figure 5.

Note: Access to the terminals can be gained by probing through the end of the Quick Connectors as shown in the illustrations.

If the DC heater is now energized when power is applied, replace the Thermostat. If not, remove jumper and go to (b.) below.

- b. With the AC and DC power disconnected, lay back the Control panel as described above and place one jumper from DC2 to W2 and another jumper from DC1 to W1 according to Figure 15. If DC is now energized when power is applied, replace the Selector Switch per replacement procedure on page 12-20.

7. If the continuity test in Step 4 indicates normal heater ohms (1.21-1.37), then the problem is not in the electrical circuit. Make sure the supply voltage is within 10.4 to 15.4 volts range with the heater operating, and check heater position to insure it is securely installed in its well.

Removal & Replacement Procedures

AC Heater Removal & Replacement



USE EXTREME CAUTION WHEN WORKING ON THE AC ELECTRICAL COMPONENTS OF THE REFRIGERATOR. BEFORE REPLACING ANY ELECTRICAL COMPONENTS, DISCONNECT THE AC POWER SOURCE TO THE REFRIGERATOR. ELECTRICAL CURRENT CAN CAUSE SEVERE ELECTRICAL SHOCK OR DEATH.

1. Disconnect the AC power cord from the AC receptacle.
2. Disconnect the two AC Heater leads from the terminal block located on top of the control panel (Terminals 1 & 2 in Figure 10).
3. Remove the screw which secures the Flue Extension tube and swing it out of the way.
4. Remove the insulation that surrounds the flue tube. Use a utility knife and cut the insulation vertically - starting above the heater.
5. Lift the AC Heater from the heater well.
6. Reinstall the new heater into the well until the stop bead on the heater touches the heater well (See Figure 18).

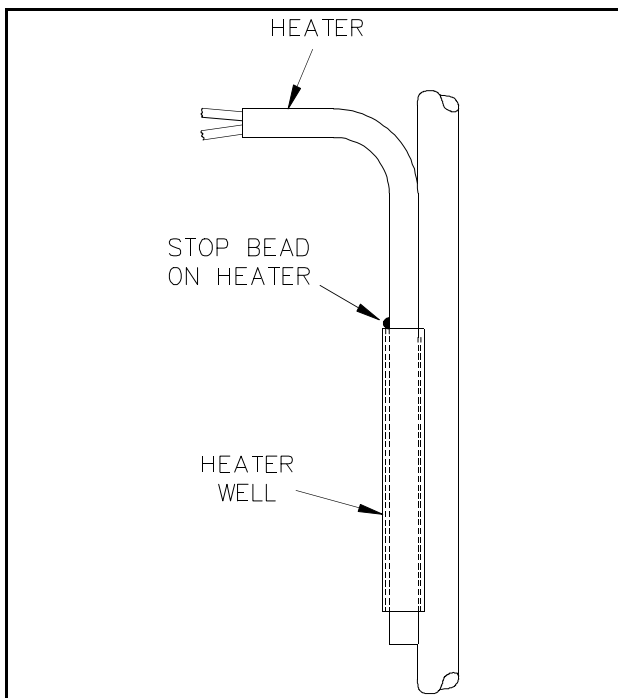

Figure 18

Reinstall the insulation around the flue tube making sure the insulation completely surrounds the flue tube.

8. Tape the insulation closed.
9. Insure that the insulation does not obstruct the opening in the flue tube.
10. Reconnect the AC Heater leads to the AC Heater terminals (Terminals 3 & 4 in Figure 10).
11. Reconnect the AC power cord to the AC receptacle.

DC Heater Removal & Replacement

1. Disconnect the DC input leads from the refrigerator, tape the positive terminal to prevent shorting to any metal surface and blowing the input fuse.
2. Insure that the Mode Selector is set for DC operation, this eliminates other energy sources from being activated.
3. Disconnect the DC Heater leads from the heater terminals located on top of the control panel (Terminals 3 & 4 in Figure 10).
4. Remove the screw which secures the Flue Extension tube and swing it out of the way.
5. Remove the insulation that surrounds the flue tube. Use a utility knife and cut the insulation vertically - starting above the heater.
6. Remove the DC Heater from the heater well.
7. Install the replacement the heater well, gliding it in until the bead stop on the heater touches the well.
8. Reinstall the insulation around the flue tube making sure the insulation completely surrounds the flue tube.
9. Tape the insulation closed.
10. Reconnect the heater leads to the DC Heater terminals (Terminals 3 & 4 in Figure 10).
11. Insure that the 20 AMP fuse is installed in the in line fuse holder.

 **WARNING**

NEVER OVERFUSE A CIRCUIT. REPLACE BLOWN FUSE WITH EXACT REPLACEMENT INDICATED BY NORCOLD. OVERFUSING OF A CIRCUIT CAN RESULT IN A FIRE.

12. Reconnect the DC input leads to the terminal block (See Figure 10). Insure that the correct polarity is observed.

Manual Shut-off Valve Removal & Replacement

 **WARNING**

USE TWO WRENCHES WHEN TIGHTENING OR UNTIGHTENING GAS FITTINGS. LEAK TEST AFTER WORKING ON ALL GAS FITTING. FAILURE TO DO SO COULD RESULT IN A FIRE OR EXPLOSION WHICH COULD CAUSE PERSONAL INJURY OR DEATH.

1. Turn off the gas supply at the main tank.
2. Remove the inlet gas supply line from the shut-off valve connector (flare fitting).
3. Remove the outlet tube fitting from the shut-off valve connector (flare fitting).

Note: Do not remove the brass fittings attached to the valve body.

4. Remove the two screws from the shut-off valve bracket.
5. Remove the two screws that secure the shut-off valve to the bracket.
6. To reinstall follow the reverse order 5 through 1.
7. Leak test all gas fittings removed.

Control Assembly Removal & Replacement

1. Turn off the gas supply at the main tank.
2. Remove all wire connections from the Terminal

Block, tagging each wire or otherwise identifying for reconnection later.

 **WARNING**

USE TWO WRENCHES WHEN TIGHTENING OR UNTIGHTENING GAS FITTINGS. LEAK TEST AFTER WORKING ON ALL GAS FITTINGS. FAILURE TO DO SO COULD RESULT IN A GAS LEAK WHICH COULD RESULT IN A FIRE OR EXPLOSION, WHICH COULD CAUSE PERSONAL INJURY OR DEATH.

3. Remove the inlet flare fitting to the Gas Control Valve.
4. Remove the outlet flare fitting from the Gas Control Valve.
5. Remove the screw that secures the Control Assembly to the cabinet.
6. Lift the Control Assembly away from the cabinet.
7. Remove the clips that secure the capillary tube to the fins, noting that the capillary tube is located on the fifth fin from the right.
8. Pull the capillary tube through the back of the cabinet.
9. To reinstall, reverse the above procedure.
10. Leak test all gas fittings removed.

Gas Control Removal & Replacement

 **WARNING**

USE TWO WRENCHES WHEN TIGHTENING OR UNTIGHTENING GAS FITTINGS. LEAK TEST AFTER WORKING ON ALL GAS FITTINGS. FAILURE TO DO SO COULD RESULT IN A GAS LEAK WHICH COULD RESULT IN A FIRE OR EXPLOSION WHICH COULD CAUSE PERSONAL INJURY OR DEATH.

1. Turn off the gas supply at the main tank and at the manual shut-off valve.
2. Remove the inlet tube flare fitting from the Gas Control Valve.

3. Remove the outlet tube flare fitting from the Gas Control Valve.
Note: Do not remove the brass elbows from the valve body.
4. Remove the two screws that secure the Gas Control Valve to the Control Assembly.
5. Remove the two red wires from the Thermocouple Adaptor.
6. Remove the Thermocouple from the Thermocouple Adapter.
7. Remove the Thermocouple Adapter from the Gas Control Valve.
8. To install a new Gas Control Valve reverse the above procedure.
9. Leak test all gas fittings removed.

Thermocouple Removal & Replacement



USE TWO WRENCHES WHEN TIGHTENING OR UNTIGHTENING GAS FITTINGS. LEAK TEST AFTER WORKING ON ALL GAS FITTINGS. FAILURE TO DO SO COULD RESULT IN A GAS LEAK WHICH COULD RESULT IN A FIRE OR EXPLOSION, WHICH COULD CAUSE PERSONAL INJURY OR DEATH.

1. Turn off the gas supply at the main tank.
2. Remove the inlet tube flare fitting from the Gas Control Valve.
3. Remove the outlet tube flare fitting from Gas Control Valve.
4. Remove the two screws that secure the Gas Control Valve to the Control Assembly.
5. Remove the Thermocouple from the Thermocouple Adapter.
6. Remove the burner box cover.
7. Remove the two screws that secures the Thermocouple bracket to the bracket.
8. Pull the Thermocouple out of the Thermocouple bracket.

9. To reinstall the Thermocouple reverse the above procedure.
10. Leak test all gas fittings removed.

Piezo Lighter Removal & Replacement



USE TWO WRENCHES WHEN TIGHTENING OR UNTIGHTENING GAS FITTINGS. LEAK TEST AFTER WORKING ON ALL GAS FITTINGS. FAILURE TO DO SO COULD RESULT IN A GAS LEAK WHICH COULD RESULT IN A FIRE OR EXPLOSION, WHICH COULD CAUSE PERSONAL INJURY OR DEATH.

1. Turn off the gas supply at the main tank.
2. Remove the burner box cover.
3. Remove the screw that secures the spark electrode to the burner bracket.
4. Remove the electrode from the burner bracket.
5. Remove the flare fitting from the Gas Control Valve inlet fitting.
6. Remove the flare fitting from the Gas Control Valve outlet fitting.
7. Remove the screw that secures the Control Assembly to the cabinet.
8. Lift the Control Assembly away from the cabinet.
9. Remove the nut that secures the Piezo Lighter to the Control Assembly and remove the Piezo Lighter.
10. To reinstall reverse the procedure.
11. Leak test all gas fittings removed.

Thermostat Removal & Replacement

WARNING

USE TWO WRENCHES WHEN TIGHTENING OR UNTIGHTENING GAS FITTINGS. LEAK TEST AFTER WORKING ON ALL GAS FITTINGS. FAILURE TO DO SO COULD RESULT IN A GAS LEAK WHICH COULD RESULT IN A FIRE OR EXPLOSION, WHICH COULD CAUSE PERSONAL INJURY OR DEATH.

1. Turn off the gas supply at the main tank.
2. Remove the inlet flare fitting to the Gas Control Valve.
3. Remove the outlet flare fitting from the Gas Control Valve.
4. Remove the screw that secures the Control Assembly to the cabinet.
5. Lift the Control Assembly away from the cabinet.
6. Remove the two screws that secure the Thermostat to the Control Assembly.
7. Remove the two red wires from the Thermostat.
8. Remove the clips that secure the capillary tube to the fins, noting that the capillary tube is located on the fifth fin from the right.
9. Pull the capillary tube through the back of the cabinet.
10. To reinstall reverse the above procedure.
11. Leak test all gas fittings removed.

Selector Switch Removal & Replacement

WARNING

USE TWO WRENCHES WHEN TIGHTENING OR UNTIGHTENING GAS FITTINGS. LEAK TEST AFTER WORKING ON ALL GAS FITTINGS. FAILURE TO DO SO COULD RESULT IN A GAS LEAK WHICH COULD RESULT IN A FIRE OR EXPLOSION, WHICH COULD CAUSE PERSONAL INJURY OR DEATH.

1. Turn off the gas supply at the main tank.
2. Remove the flare fitting from the inlet tube of the Gas Control Valve.
3. Remove the outlet tube flare fitting from the Gas Control Valve.
4. Remove the screws that secures the Control Assembly to the cabinet.
5. Lift the Control Assembly away from the cabinet.
6. Remove the selector switch knob.
7. Remove the two screws that secure the selector switch to the Control Assembly.
8. Lift the selector switch away from the control bracket.
9. Remove the wires from the selector switch one at a time and connect to the new switch exactly as removed. Double check the wiring connections with the wiring diagrams as follows:
 - Orange wires to G3 & W3
 - Red wires from Thermostat to W2 & W3
 - Red wires from fuse & terminal block to AC1 & AC2
 - Blue wires to DC1 & DC2
10. To reinstall, reverse Steps 7-1.
11. Leak test all gas fittings removed.

Orifice Removal & Replacement

WARNING

USE TWO WRENCHES WHEN TIGHTENING OR UNTIGHTENING GAS FITTINGS. LEAK TEST AFTER WORKING ON ALL GAS FITTINGS. FAILURE TO DO SO COULD RESULT IN A GAS LEAK WHICH COULD RESULT IN A FIRE OR EXPLOSION, WHICH COULD CAUSE PERSONAL INJURY OR DEATH.

1. Turn off the gas supply at the main tank.
2. Remove the flare nut from the orifice assembly.
3. Remove the orifice assembly from the burner.

Note: Do not attempt to remove the orifice body from the brass adapter since the orifice is pressed on at the factory to assure a good seal.

4. Install orifice assembly, insure orifice assembly is wrench tight in burner.
5. Reconnect flare nut to orifice assembly.
6. Leak test all gas fittings removed.

Burner Removal & Replacement



USE TWO WRENCHES WHEN TIGHTENING OR UNTIGHTENING GAS FITTINGS. LEAK TEST AFTER WORKING ON ALL GAS FITTINGS. FAILURE TO DO SO COULD RESULT IN A GAS LEAK WHICH COULD RESULT IN A FIRE OR EXPLOSION, WHICH COULD CAUSE PERSONAL INJURY OR DEATH.

1. Turn off the gas supply at the main tank.
2. Remove the flare nut from the burner orifice assembly.
3. Remove the burner box cover.
4. Remove the screw that secures the burner to the burner bracket, and pull the burner from the bracket.
5. Remove the orifice assembly from the burner.
6. To reinstall reverse the procedure.
7. Leak test gas fittings removed.

Refrigerator Removal & Reinstallation

1. Remove the AC cord from the AC receptacle.
2. Turn off the gas supply at the main tank.
3. Remove the LP gas supply line from inlet fitting.
4. Remove the two screws from the back of the refrigerator that secure the refrigerator to the floor.
5. Remove the four screws from the breaker that secure the refrigerator into the cut-out opening.
6. Slide the refrigerator forward and lift out of the opening.
7. To reinstall, insure that the seal strips around the breakers are in place and reinstall by reversing Steps 6 through 1.



CARE MUST BE EXERCISED UPON REMOVAL AND RE-INSTALLATION OF THE REFRIGERATOR TO INSURE THAT THE SEAL STRIPS LOCATED BEHIND THE MOUNTING FLANGES ARE NOT DAMAGED, MISPLACED OR MISALIGNED. THESE SEALS SERVE AS A COMBUSTION SEAL WHICH PREVENTS EXHAUST FUMES FROM ENTERING INTO THE LIVING QUARTERS.

8. Leak test all gas fittings removed.

Wiring Diagrams

