

# Service schematics

# Nokia 500

## RM-750

### IMPORTANT

This document is intended for use by authorized Nokia service centers only. Please use the document together with other documents such as the Service Manual and Service Bulletins.

### Version information

While every effort has been made to ensure that the document is accurate, some errors may exist. Please always check for the latest published version for this document.

If you find any errors in the document please send email to: [service.manuals@nokia.com](mailto:service.manuals@nokia.com)

1.0 First approved version.



### Contents

Front page	1
RAPUYAMA, Memory, Camera, Sensors	2
RAPUYAMA, Charger, HS USB	3
RAPUYAMA, Touch IF, Display IF, UI keys, UI LEDs	4
GAZOO, Battery, Audio, AV-connector, $\mu$ SD, SIM	5
BTH FM, WLAN, GPS	6
RF part	7
Component finder top	8
Component finder bottom	9

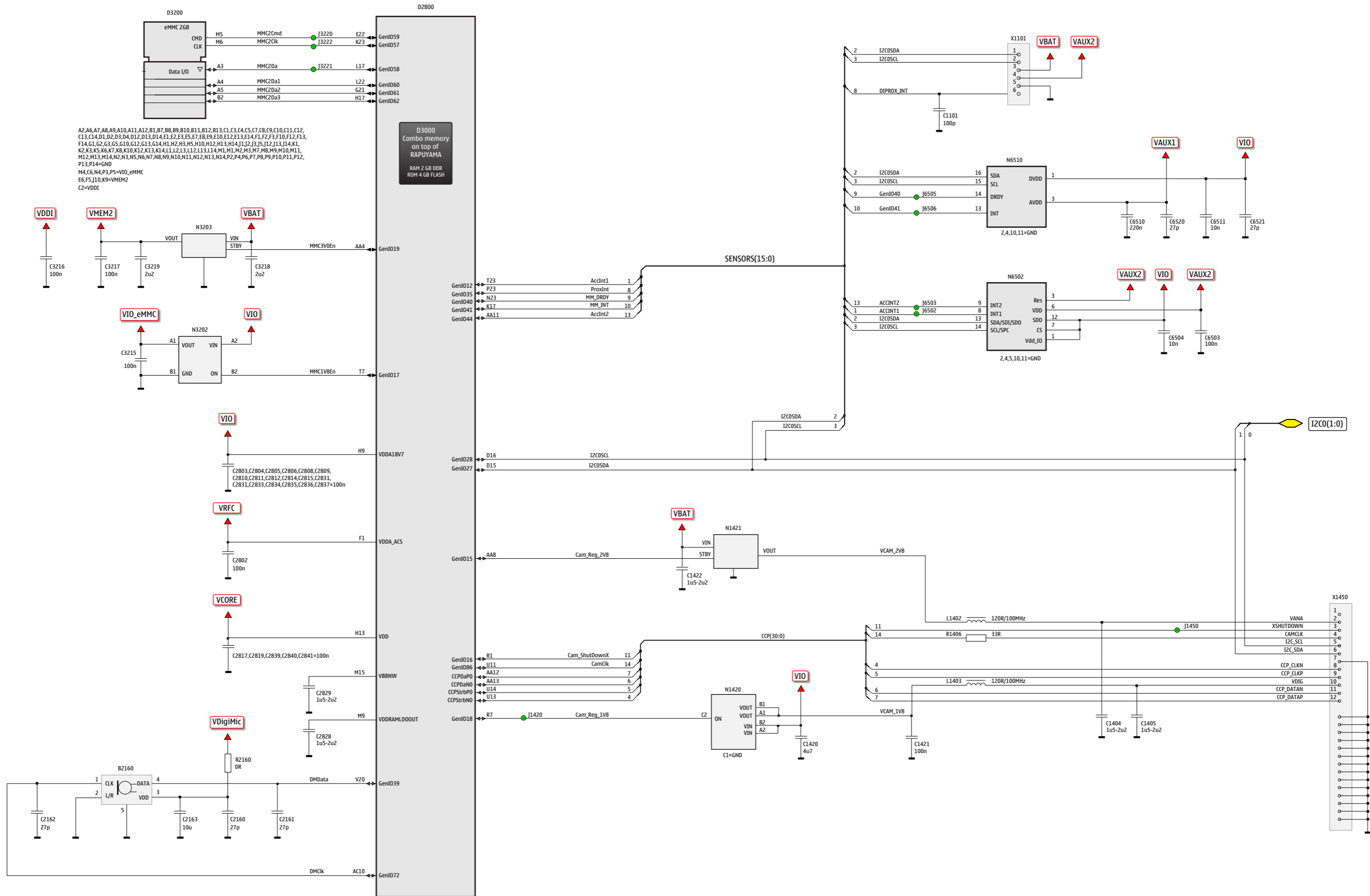

A4, A5, A7, A9, A10, A12, A15, A16, A17, A18, A21, A21, AA1, AA15, AA23, AC5, AC6, AC7, AC8, AC13, AC15, B3, B19, C12, C18, C23, D1, D8, D9, D18, D23, E1, E3, E23, F23, G10, H1, H7, H23, J1, K1, L1, N2, N21, P1, T1, T2, U1, V23, V23=VIO  
H14, M15, J8, J9, J10, J11, J12, J15, J16, K8, L8, L16, M8, M16, N8, N15, P8, P9, R11, R12, R13, R14, R15, R16, T8, T9, T12, T15, T19=VCORE  
A13, AA2, AA14, AA20, AA22, AB2, AB5, AB8, AB10, AB13, AC4, AC12, B4, B5, B7, B8, B10, B12, B15, B15, B18, B22, C9, C10, C15, C16, C17, C19, C21, C22, D17, D21, E2, E5, F2, F22, G1, G8, G16, H2, H8, H10, H11, H16, H22, J13, J14, K2, K9, K15, K16, K22, L2, L9, L15, M1, N16, P2, P9, P15, P16, P20, R10, T11, T14, T16, U2, U23, V12=GND



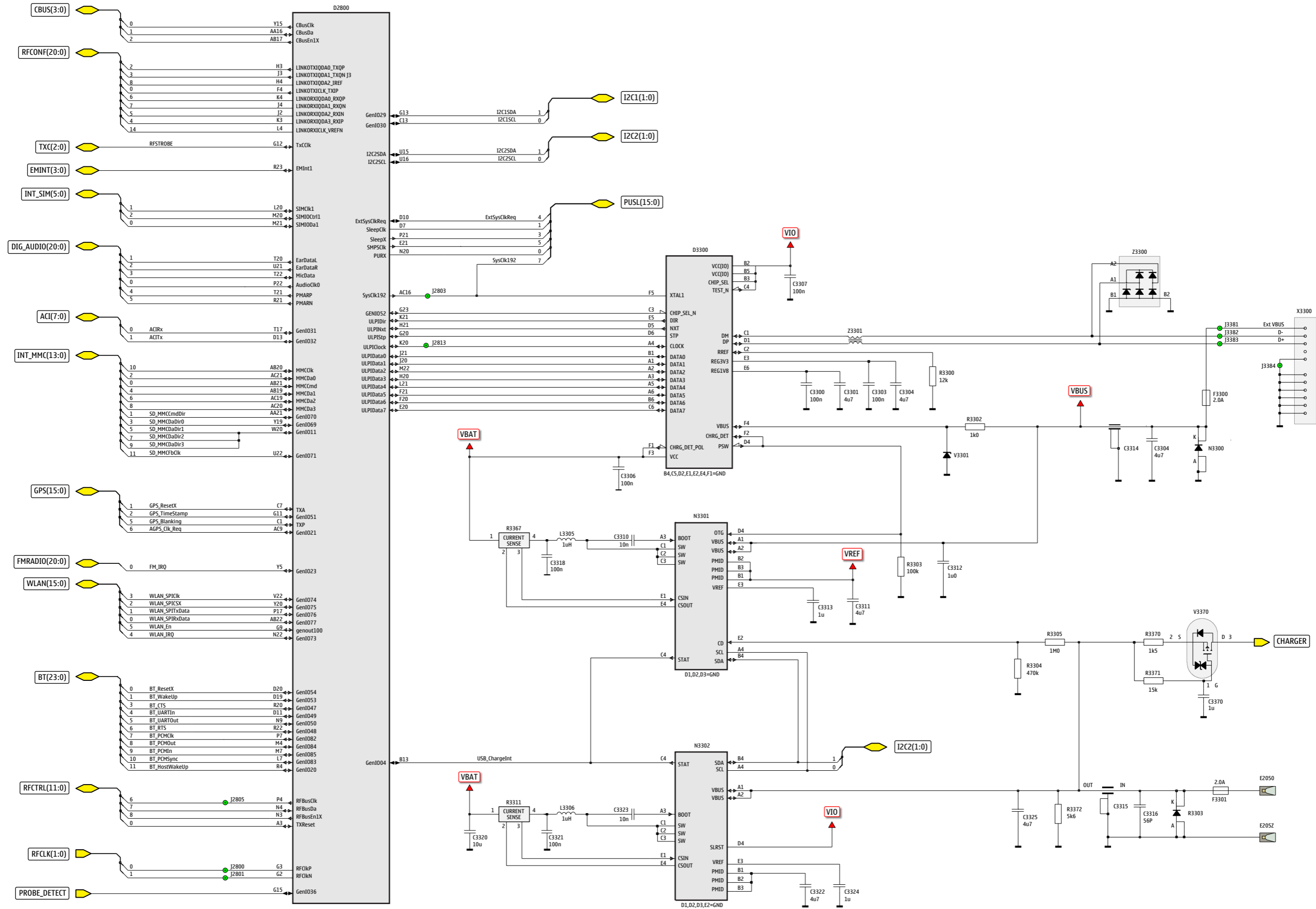

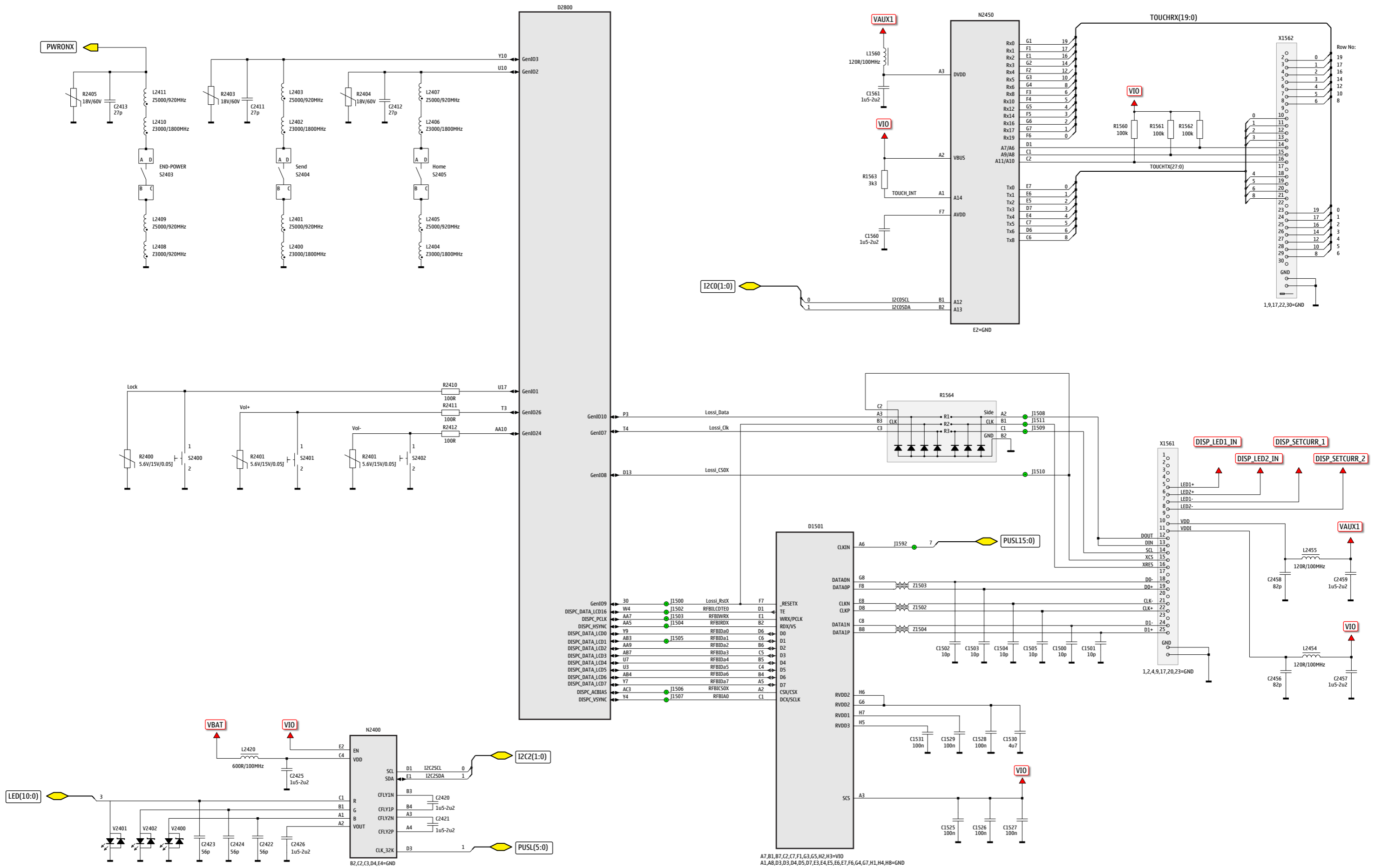

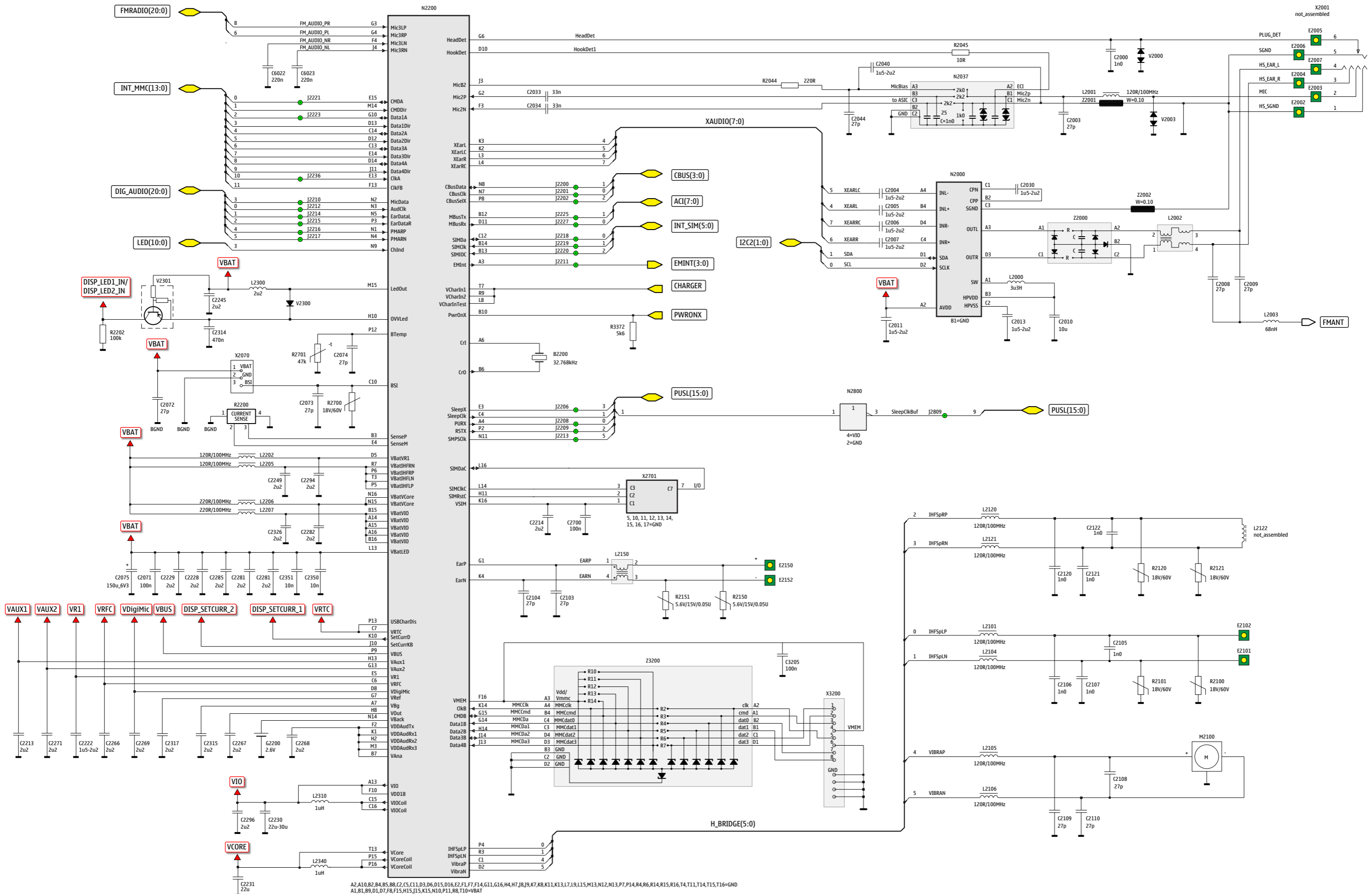

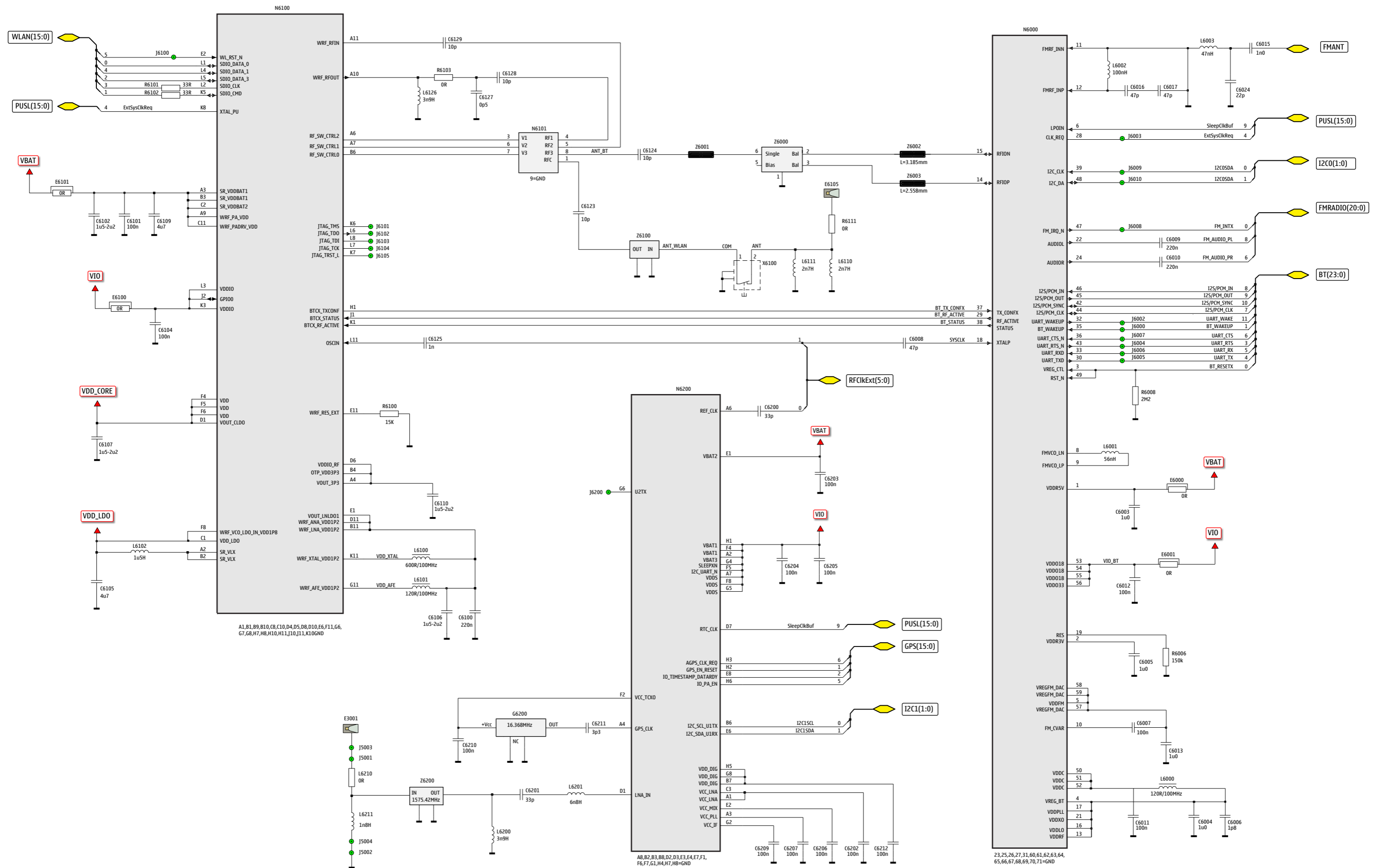



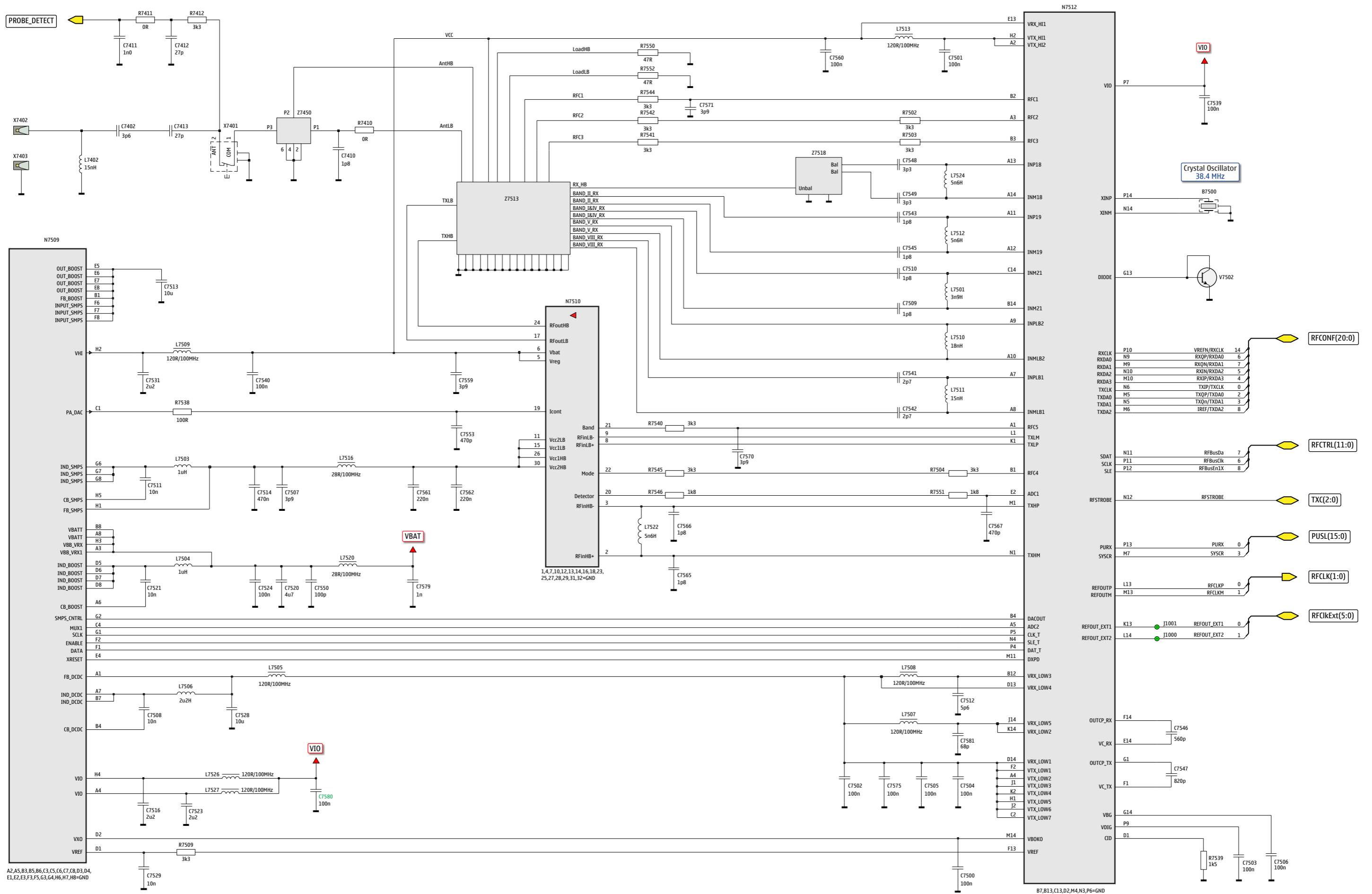

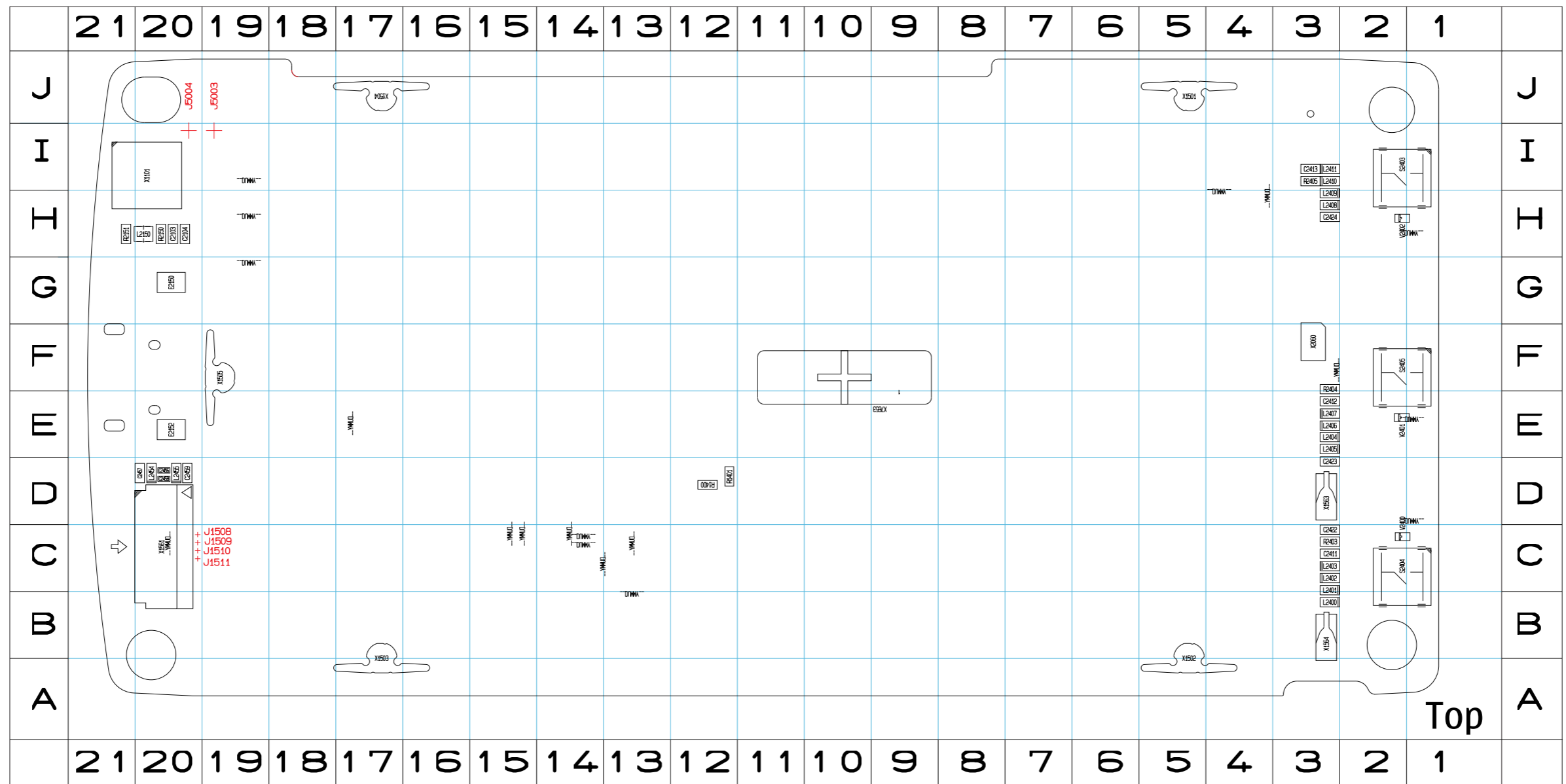

C	C2459	D20	L2406	E3	R2151	H21	X
C2103	H20	E	L2407	E3	R2403	C3	X1101 I20
C2104	H20	E2150	G20	L2408	H3	R2404	F3 X1501 J5
C2411	C3	E2152	E20	L2409	H3	R2405	I3 X1502 B5
C2412	E3	L	L2410	I3	S		X1503 B17
C2413	I3	L2150	H20	L2411	I3	S2403	I2 X1504 J17
C2422	C3	L2400	B3	L2454	D20	S2404	C2 X1505 F19
C2423	D3	L2401	C3	L2455	D20	S2405	F2 X1561 C20
C2424	H3	L2402	C3	R	V		X1563 D3
C2456	D20	L2403	C3	R1400	D12	V2400	C2 X1564 B3
C2457	D20	L2404	E3	R1401	D12	V2401	E2 X2060 F3
C2458	D20	L2405	E3	R2150	H20	V2402	H2



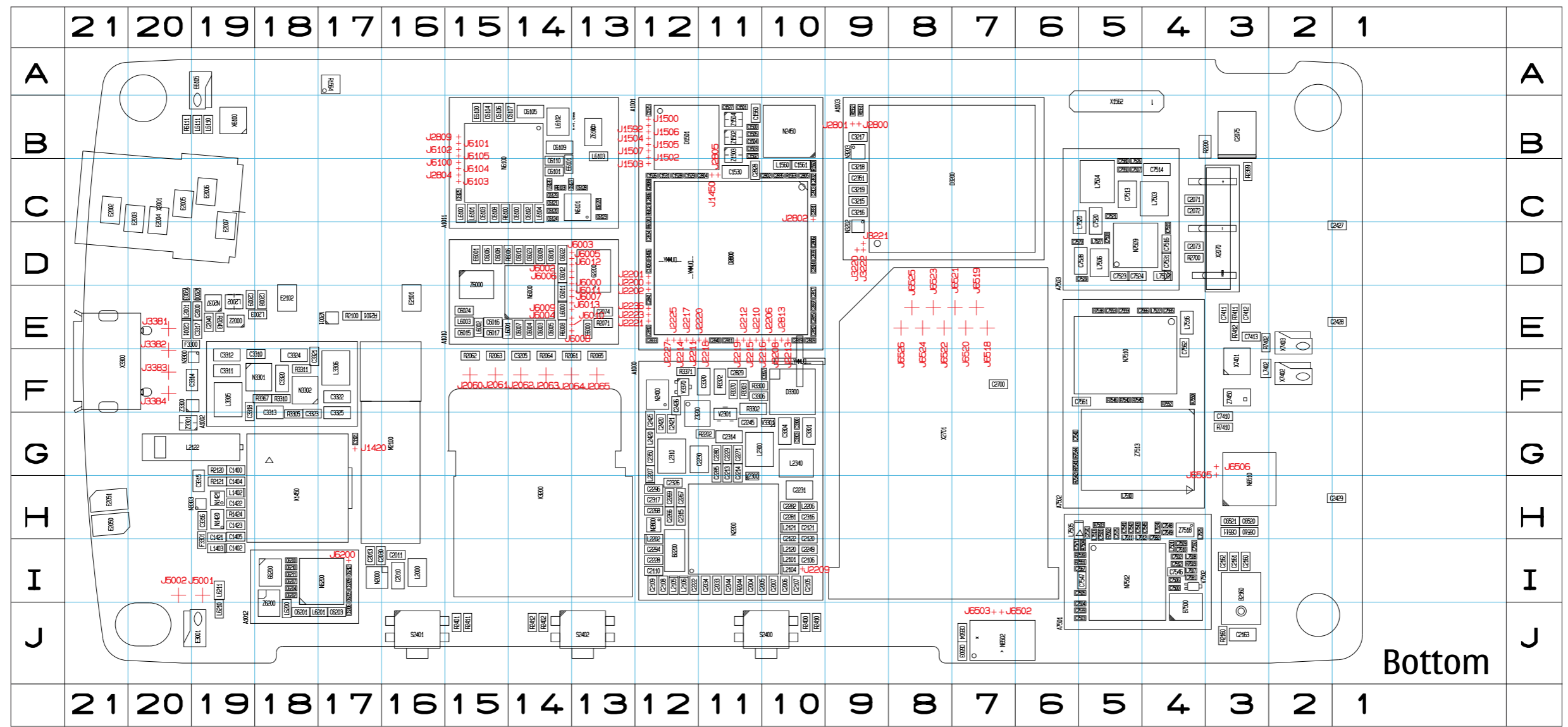

<b>A</b>	C1423	H19	C2010	I16	C2162	I3	C2316	H10	C2815	E10	C3304	G10	C6008	D15	C6121	C14	C6520	H3	C7523	D5	C7570	H5	E3001	J19	L2206	H10	L7402	F3	N1421	H19	R1424	H19	R2402	J14	R7411	E3	V2003	E20	Z3300	F19	
A1000	H11	C1500	B11	C2011	I16	C2163	J3	C2317	H12	C2817	E10	C3306	F11	C6009	D14	C6122	C13	C6521	H3	C7524	D5	C7571	I6	E6105	A19	L2207	G12	L7501	I4	N2000	I17	R1560	C10	R2410	J10	R7412	E3	V2300	H11	Z3301	G20
A1001	D11	C1501	B11	C2013	I17	C2213	G11	C2326	H12	C2819	E10	C3307	F10	C6010	D14	C6123	C13	C7410	G3	C7528	D5	C7575	H5	<b>F</b>	L2300	G11	L7503	C4	N2037	E19	R1561	B9	R2411	J15	R7502	H5	V2301	G11	Z6000	D15	
A1002	F18	C1502	B11	C2030	I17	C2214	G11	C2350	G12	C2828	C11	C3310	F18	C6011	E14	C6124	C14	C7411	E3	C7529	D5	C7579	D6	F3300	E20	L2310	G12	L7504	C5	N2200	H11	R1562	B9	R2412	J14	R7503	H5	V3301	G10	Z6100	B13
A1003	C8	C1503	B11	C2033	I11	C2222	I12	C2351	C9	C2829	F11	C3311	F19	C6012	D14	C6125	C15	C7412	E3	C7531	D4	C7580	C5	F3301	I19	L2340	G10	L7505	H5	N2400	F12	R1563	C10	R2700	D4	R7504	I5	V3370	F12	Z6200	J18
A1010	E14	C1504	B11	C2034	I11	C2228	I12	C2420	G12	C2831	C10	C3312	F19	C6013	D14	C6127	C14	C7413	E3	C7539	J5	C7581	I4	<b>G</b>	L2420	G12	L7506	D5	N2450	B10	R1564	A17	R3300	F11	R7509	I4	V7502	I4	Z7450	F3	
A1011	C14	C1505	B11	C2040	E19	C2229	G11	C2421	G12	C2832	C10	C3313	G18	C6015	E15	C6128	C13	C7500	I4	C7540	G6	C7582	H4	G2200	D13	L3305	F19	L7507	I4	N2800	H12	R2043	E19	R3302	F11	R7538	E5	<b>X</b>	Z7513	G5	
A1012	I18	C1525	B12	C2044	I11	C2230	G11	C2425	G12	C2833	E12	C3314	F19	C6016	E15	C6129	C14	C7501	H5	C7541	H5	<b>D</b>	G6200	I18	L3306	F17	L7508	I4	N3202	D9	R2044	I11	R3303	F11	R7539	I5	X1450	H18	Z7518	H4	
A7501	I5	C1526	C12	C2071	C4	C2231	H10	C2426	F12	C2834	D12	C3315	H19	C6017	E15	C6200	I18	C7502	I4	C7542	H5	D1501	B12	<b>L</b>	L6000	E14	L7509	D4	N3203	B9	R2061	F14	R3305	G18	R7540	F5	X1562	B5			
A7502	F5	C1527	B11	C2072	C4	C2245	G11	C2427	D1	C2835	C10	C3316	H19	C6022	D14	C6201	J18	C7503	J5	C7543	H5	D2800	D11	L1402	H19	L6001	E15	L7510	H5	N3300	F19	R2062	F15	R3310	F18	R7541	G6	X2001	C20		
A7503	C5	C1528	C12	C2073	D4	C2249	I10	C2428	E1	C2836	D10	C3317	E19	C6023	D14	C6202	I18	C7504	J5	C7545	H4	D3000	D11	L1403	I19	L6002	E15	L7511	H5	N3301	F18	R2063	F15	R3311	F18	R7542	H6	X2070	D3		
<b>B</b>	C1529	C12	C2074	E13	C2266	H12	C2429	H1	C2837	E10	C3318	F19	C6024	E15	C6203	J17	C7505	I5	C7546	I4	D3200	C7	L1560	C10	L6003	E15	L7512	H5	N3302	F18	R2064	F14	R3367	F18	R7544	G6	X2701	H8			
B2160	I3	C1530	C11	C2075	B3	C2267	H12	C2700	F7	C2839	D10	C3320	F18	C6100	C14	C6204	I18	C7506	I4	C7547	I5	D3300	F10	L2000	I16	L6100	C15	L7513	H5	N3303	H19	R2065	F13	R3370	F11	R7545	F5	X3200	H14		
B2200	I12	C1531	C12	C2105	I10	C2268	H12	C2802	C10	C2840	E11	C3321	F18	C6101	C14	C6205	I17	C7507	C5	C7548	H4	<b>E</b>	L2001	E20	L6101	C15	L7516	E4	N6000	E14	R2071	E13	R3371	F12	R7546	F5	X3300	F21			
B7500	J4	C1560	B11	C2106	I10	C2269	H12	C2803	C10	C2841	E12	C3322	F17	C6102	C14	C6206	J17	C7508	D5	C7549	H4	E2002	C21	L2002	E19	L6102	B14	L7520	D5	N6100	C15	R2100	E17	R3372	F11	R7550	F4	X6100	B19		
<b>C</b>	C1561	C10	C2107	I10	C2271	G11	C2804	C11	C3205	F14	C3323	G18	C6103	C15	C6207	I18	C7509	I4	C7550	C5	E2003	C20	L2003	E18	L6103	B13	L7522	E4	N6101	C13	R2101	E17	R6006	D15	R7551	I5	X7401	F3			
C1101	G17	C2000	E19	C2108	I12	C2280	G11	C2805	C10	C3215	C9	C3324	F18	C6104	B15	C6209	I17	C7510	I4	C7553	E5	E2004	C20	L2101	I10	L6104	C14	L7524	H4	N6200	I17	R2120	G19	R6008	E14	R7552	F4	X7402	F2		
C1400	G19	C2001	E20	C2109	I12	C2281	H10	C2806	C12	C3216	C9	C3325	G17	C6105	B14	C6210	I18	C7511	D4	C7559	E5	E2005	C20	L2104	I10	L6110	B19	L7525	H4	N6502	J7	R2121	H19	R6100	C15	<b>S</b>	X7403	E2			
C1402	I19	C2004	I11	C2110	I12	C2282	H10	C2808	C12	C3217	B9	C3370	F11	C6106	B15	C6211	I18	C7512	I4	C7560	I4	E2006	C19	L2105	I12	L6111	B19	L7526	C5	N6510	H3	R2160	J3	R6101	D12	S2400	J10	<b>Z</b>			
C1404	H19	C2005	I10	C2120	H10	C2285	G11	C2809	E10	C3218	C9	C6003	E14	C6107	B14	C6212	I17	C7513	C5	C7561	F5	E2007	D19	L2106	I12	L6126	C14	L7527	D5	N7509	D5	R2200	B4	R6102	C12	S2401	J16	Z1502	B11		
C1405	H19	C2006	I10	C2121	H10	C2294	I12	C2810	E12	C3219	C9	C6004	E14	C6108	C15	C6503	J7	C7514	C4	C7562	E4	E2050	H21	L2120	I10	L6200	J18	<b>M</b>	N7510	F5	R2202	G11	R6103	C14	S2402	J13	Z1503	B11			
C1406	D12	C2007	I10	C2122	H10	C2296	H12	C2811	E11	C3300	G10	C6005	E14	C6109	B14	C6504	J7	C7516	D4	C7565	E4	E2051	H21	L2121	H10	L6201	J17	M2100	G16	N7512	I5	R2399	C3	R6111	B20	<b>V</b>	Z1504	B11			
C1421	H19	C2008	E18	C2160	I3	C2314	G11	C2812	E10	C3301	G10	C6006	D15	C6110	C14	C6510	H3	C7520	C5	C7566	E4	E2101	E16	L2122	G20	L6210	J19	<b>N</b>	<b>R</b>	R2400	J10	R7402	E3	V2000	E19	Z2000	E19				
C1422	H19	C2009	E19	C2161	I3	C2315	H12	C2814	D10	C3303	G10	C6007	E14	C6120	C14	C6511	H3	C7521	C5	C7567	I5	E2102	E18	L2202	I12	L6211	I19	N1420	H19	R1406	D12	R2401	J15	R7410	G3	V2001	E17	Z3200	G12		