

GND contact for top cover

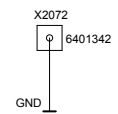

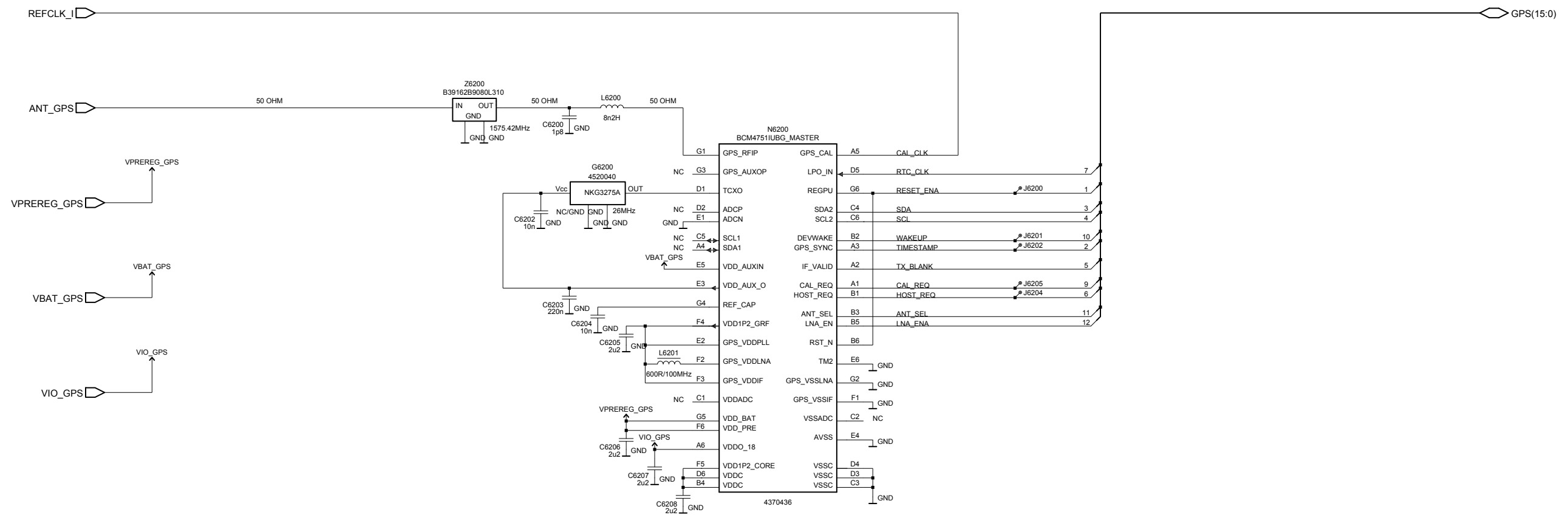

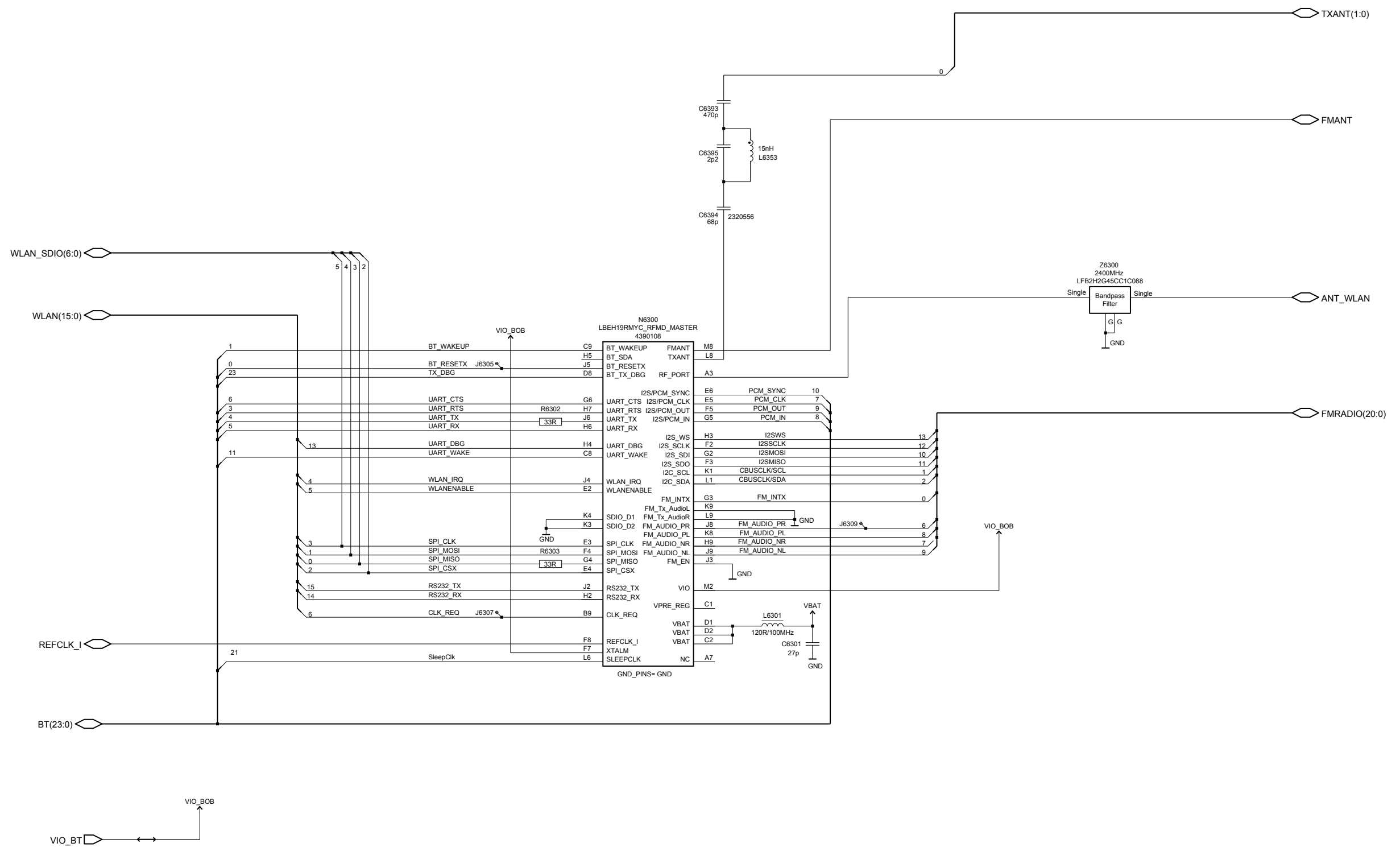

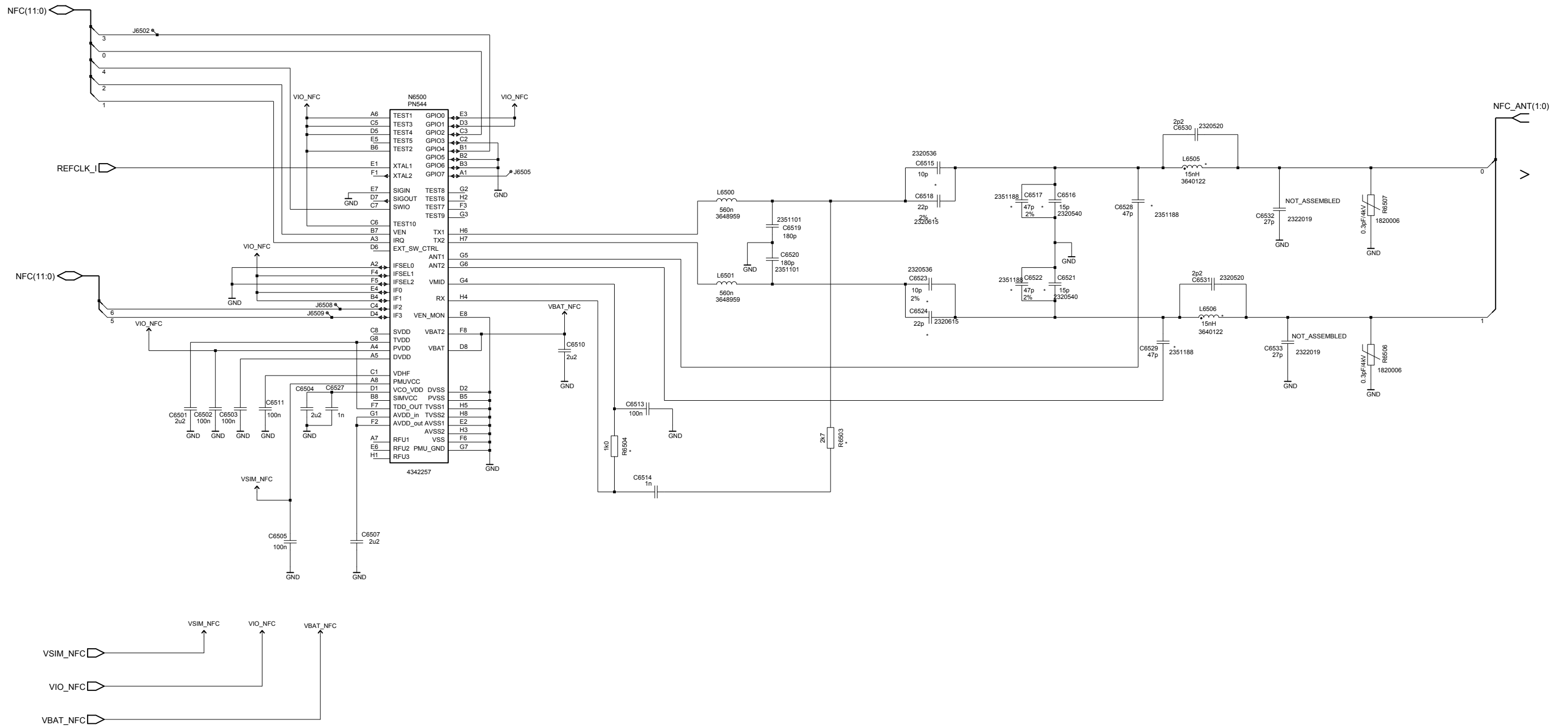

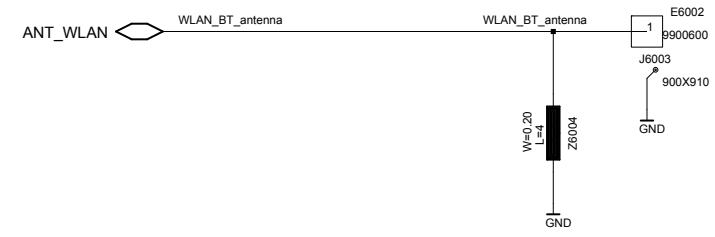
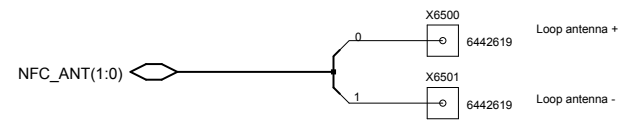
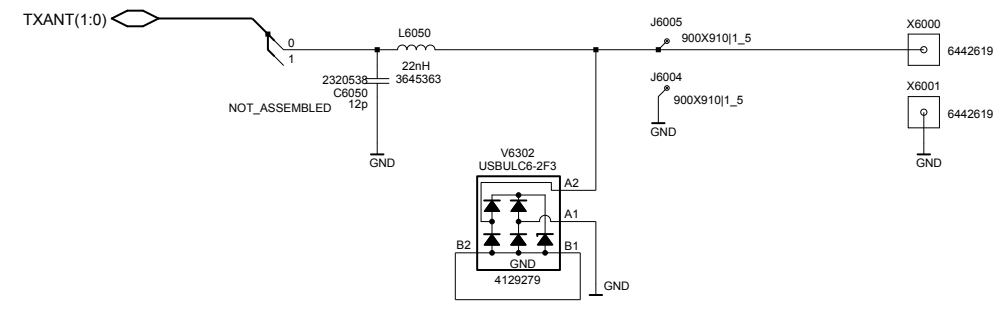
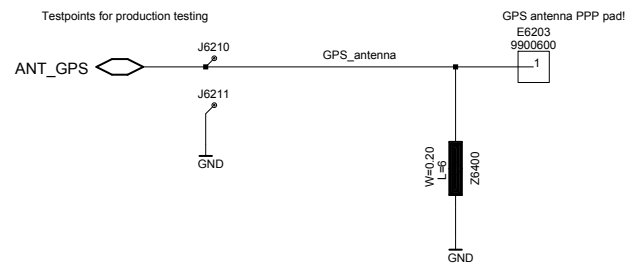
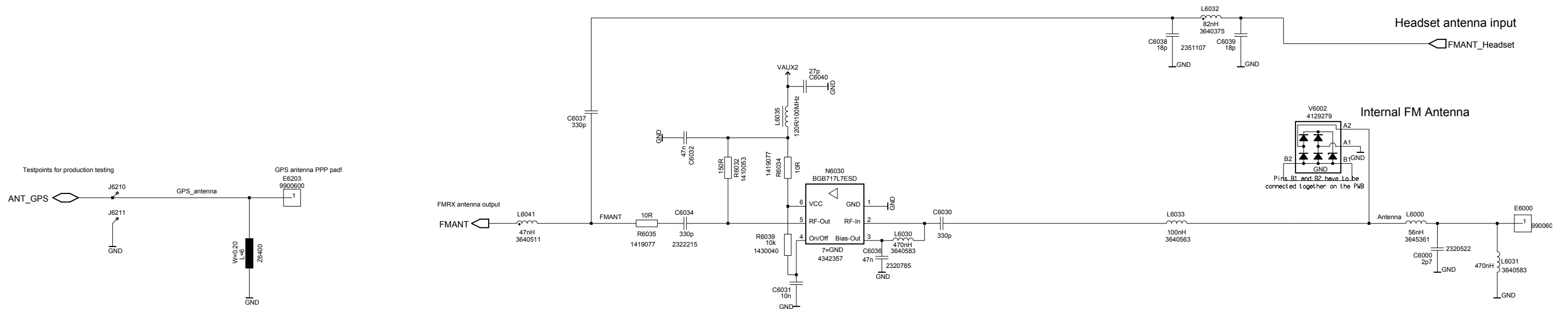

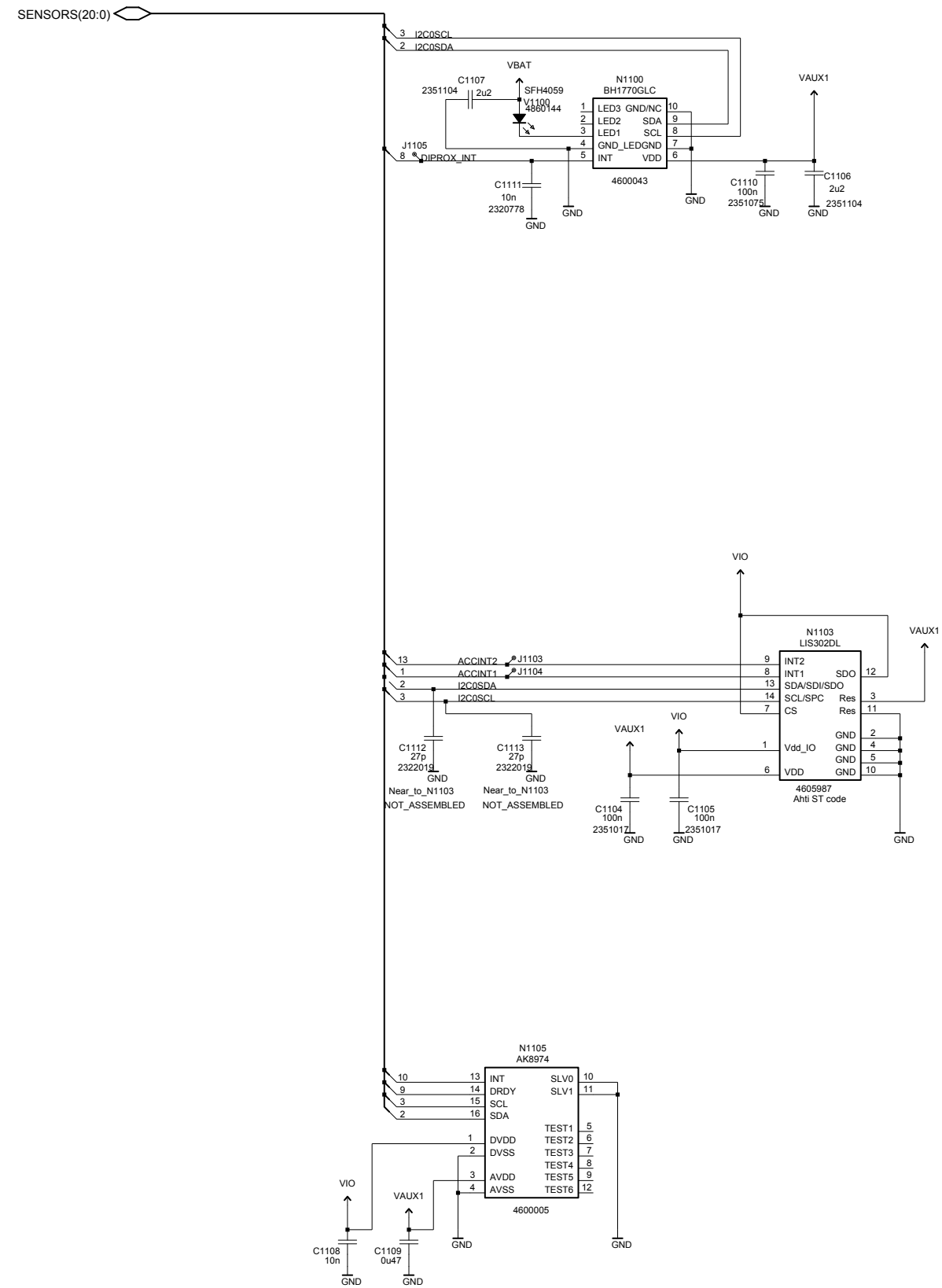

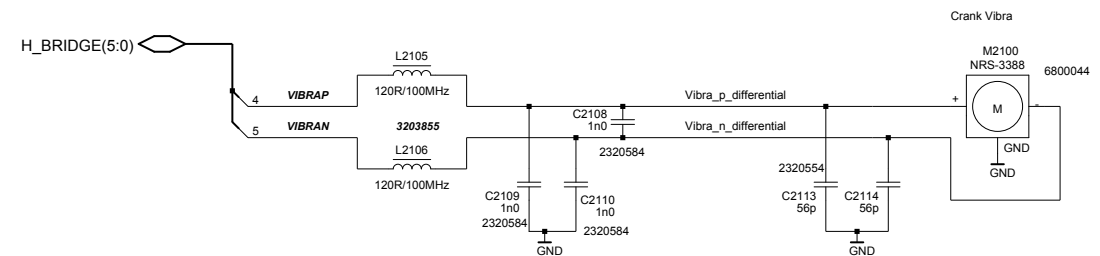
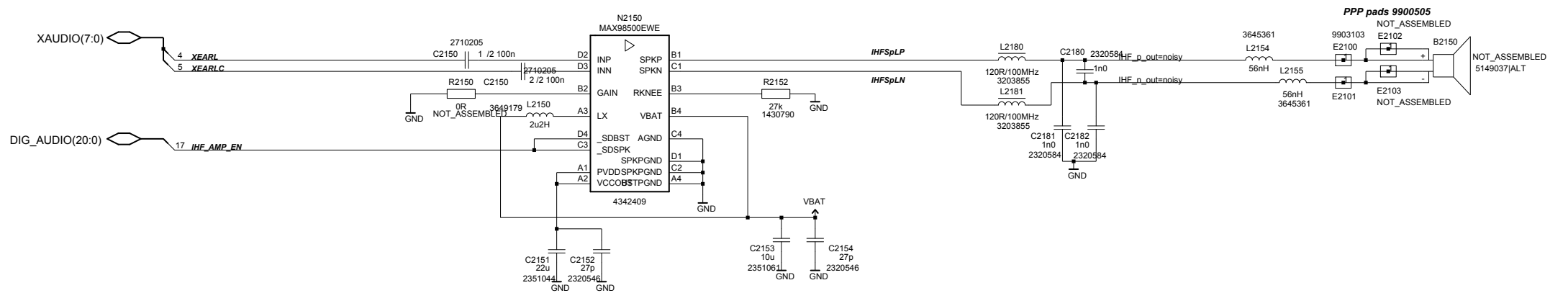
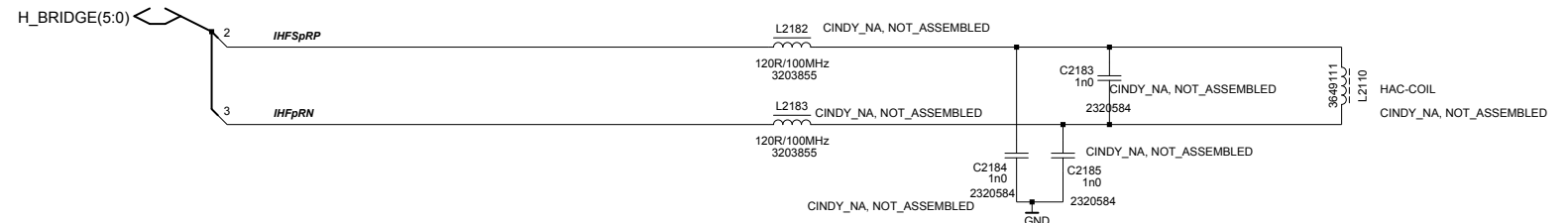
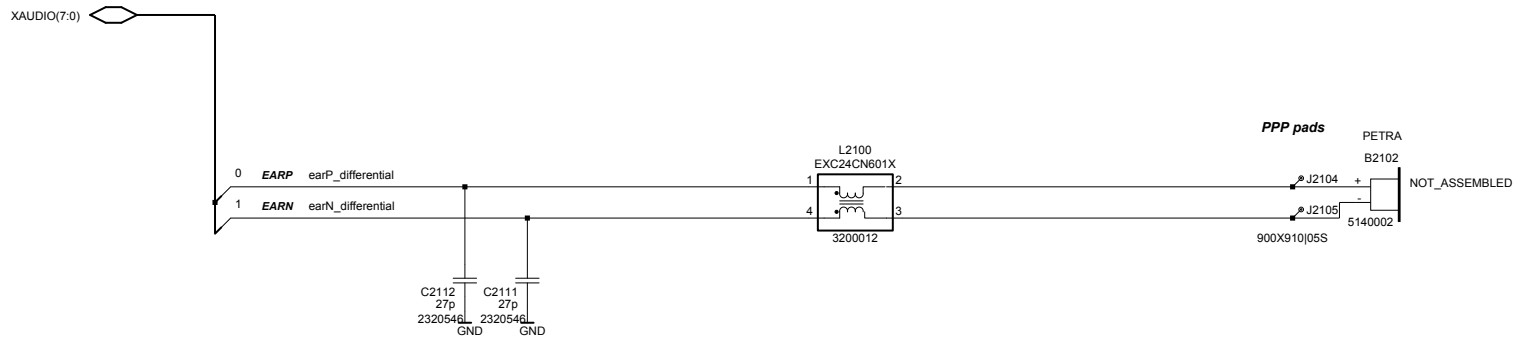
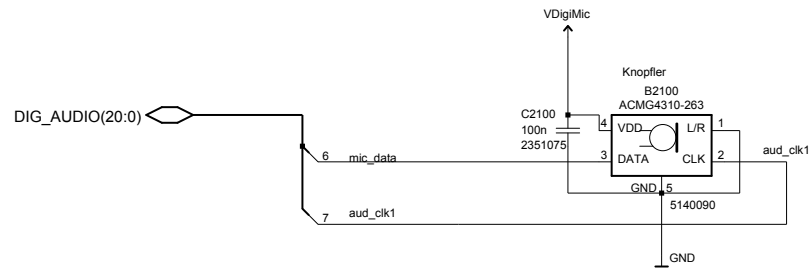

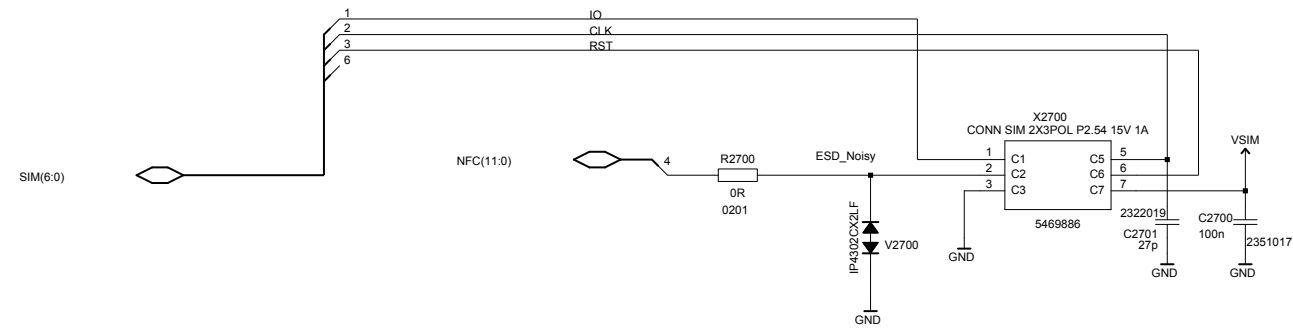

Variant Identification:

Solder on PAD, if ROW variant



Variant Identification:

Solder on PAD, if North AM variant



Atmel Capacitive touch

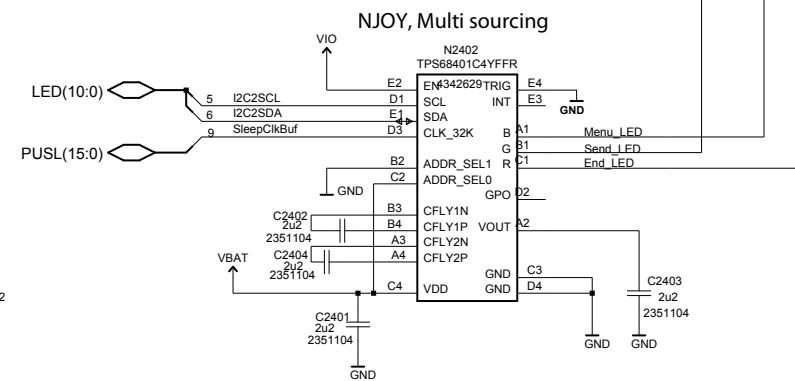
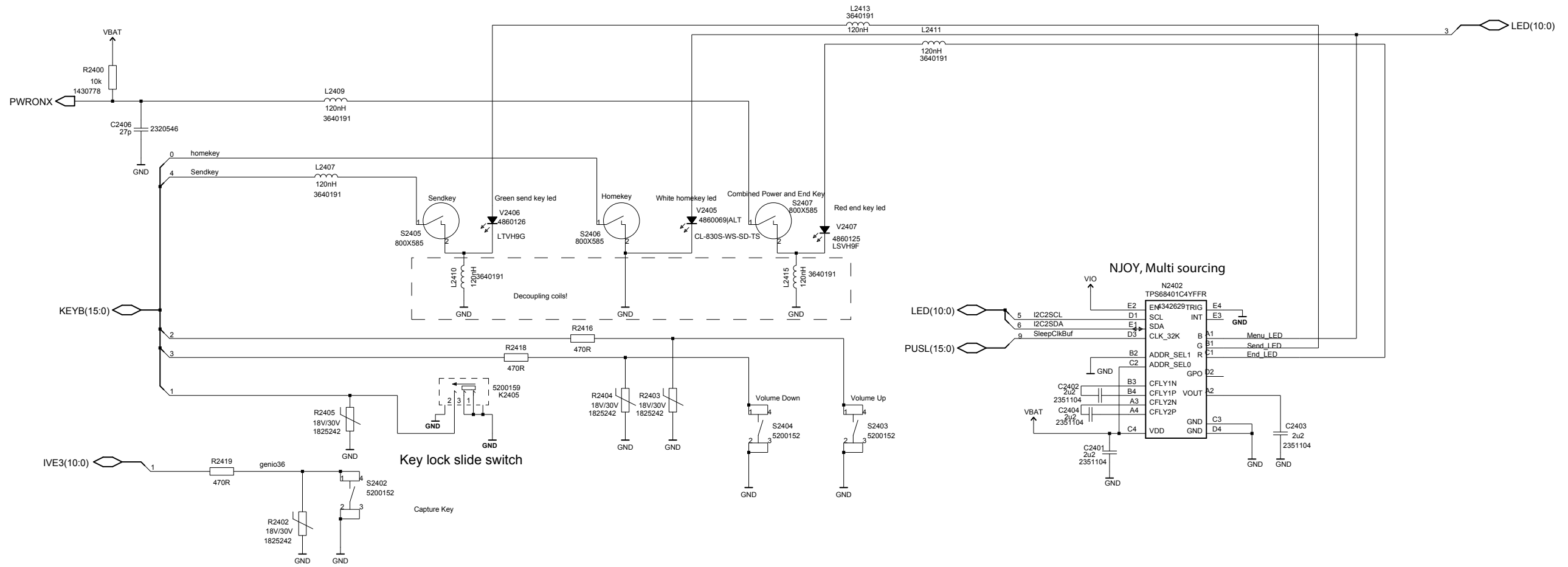
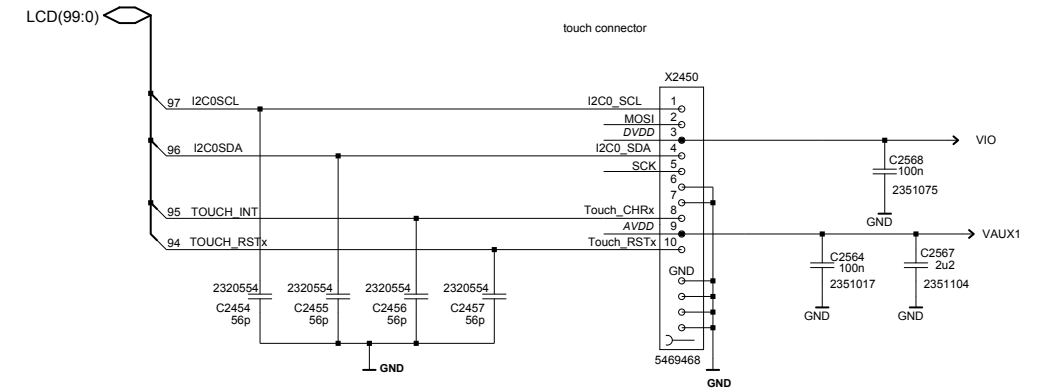

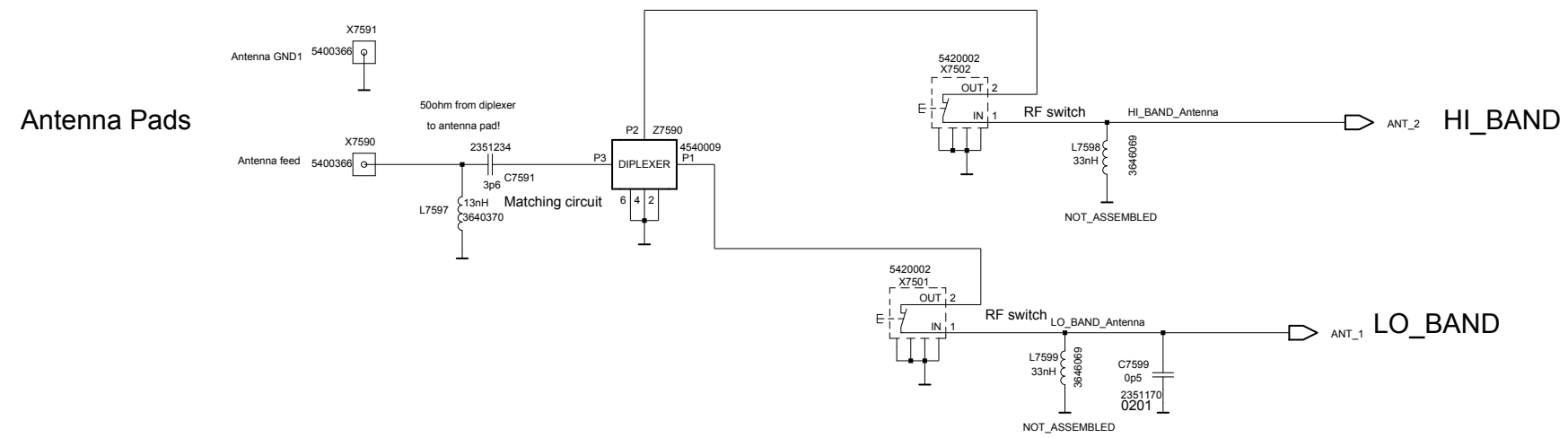

Antenna Pads

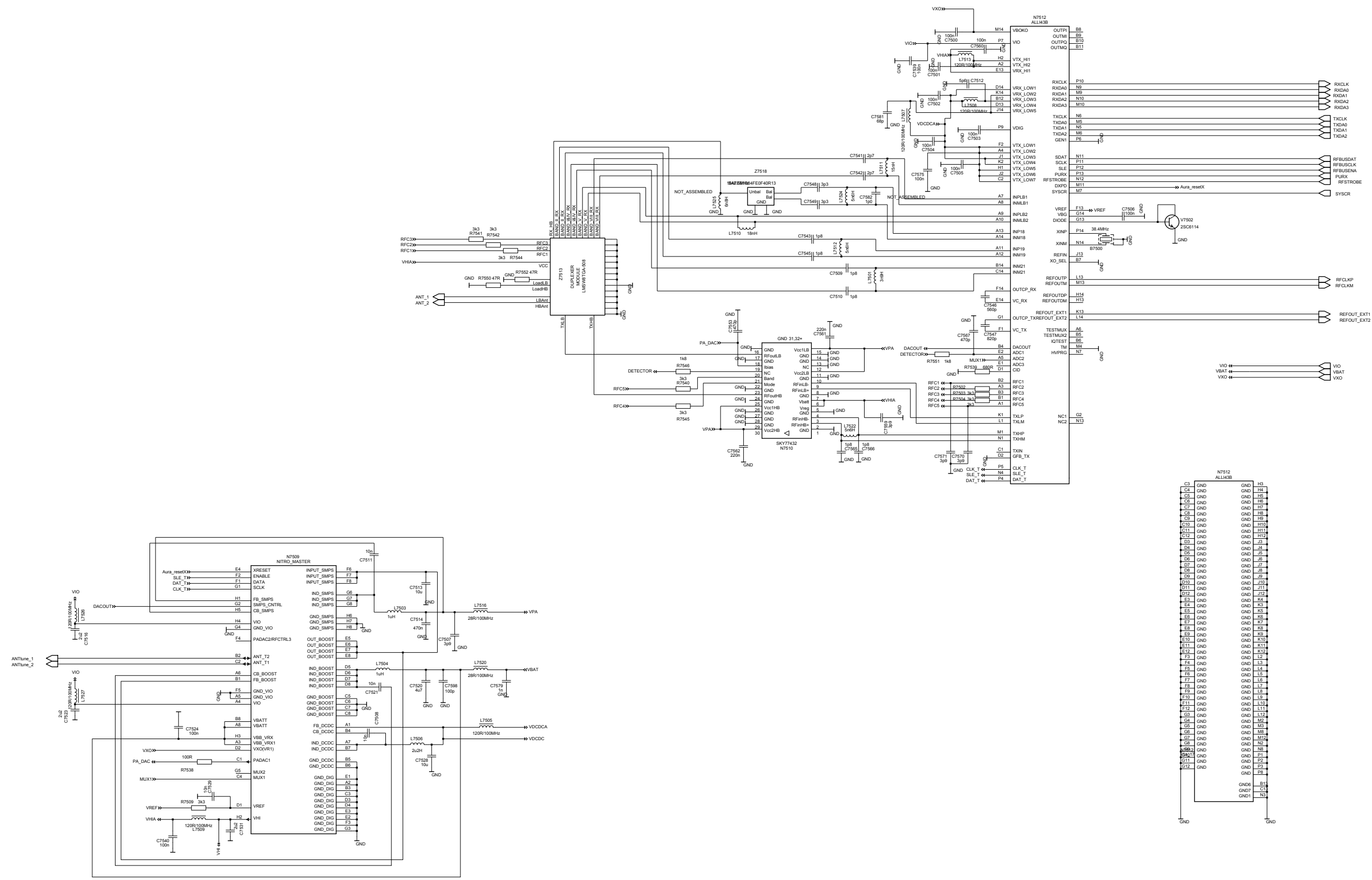

N7512 ALL43B

C3	GND	H9
C4	GND	H4
C5	GND	H5
C6	GND	H6
C7	GND	H7
C8	GND	H8
C9	GND	H9
C10	GND	H10
C11	GND	H11
C12	GND	H12
D1	GND	J1
D2	GND	J2
D3	GND	J3
D4	GND	J4
D5	GND	J5
D6	GND	J6
D7	GND	J7
D8	GND	J8
D9	GND	J9
D10	GND	J10
D11	GND	J11
D12	GND	J12
E1	GND	K1
E2	GND	K2
E3	GND	K3
E4	GND	K4
E5	GND	K5
E6	GND	K6
E7	GND	K7
E8	GND	K8
E9	GND	K9
E10	GND	K10
E11	GND	K11
E12	GND	K12
F1	GND	L1
F2	GND	L2
F3	GND	L3
F4	GND	L4
F5	GND	L5
F6	GND	L6
F7	GND	L7
F8	GND	L8
F9	GND	L9
F10	GND	L10
F11	GND	L11
F12	GND	L12
G1	GND	L13
G2	GND	L14
G3	GND	L15
G4	GND	L16
G5	GND	L17
G6	GND	L18
G7	GND	L19
G8	GND	L20
G9	GND	L21
G10	GND	L22
G11	GND	L23
G12	GND	L24
G13	GND	L25
G14	GND	L26
G15	GND	L27
G16	GND	L28
G17	GND	L29
G18	GND	L30
G19	GND	L31
G20	GND	L32
G21	GND	L33
G22	GND	L34
G23	GND	L35
G24	GND	L36
G25	GND	L37
G26	GND	L38
G27	GND	L39
G28	GND	L40
G29	GND	L41
G30	GND	L42
G31	GND	L43
G32	GND	L44
G33	GND	L45
G34	GND	L46
G35	GND	L47
G36	GND	L48
G37	GND	L49
G38	GND	L50
G39	GND	L51
G40	GND	L52
G41	GND	L53
G42	GND	L54
G43	GND	L55
G44	GND	L56
G45	GND	L57
G46	GND	L58
G47	GND	L59
G48	GND	L60
G49	GND	L61
G50	GND	L62
G51	GND	L63
G52	GND	L64
G53	GND	L65
G54	GND	L66
G55	GND	L67
G56	GND	L68
G57	GND	L69
G58	GND	L70
G59	GND	L71
G60	GND	L72
G61	GND	L73
G62	GND	L74
G63	GND	L75
G64	GND	L76
G65	GND	L77
G66	GND	L78
G67	GND	L79
G68	GND	L80
G69	GND	L81
G70	GND	L82
G71	GND	L83
G72	GND	L84
G73	GND	L85
G74	GND	L86
G75	GND	L87
G76	GND	L88
G77	GND	L89
G78	GND	L90
G79	GND	L91
G80	GND	L92
G81	GND	L93
G82	GND	L94
G83	GND	L95
G84	GND	L96
G85	GND	L97
G86	GND	L98
G87	GND	L99
G88	GND	L100
G89	GND	L101
G90	GND	L102
G91	GND	L103
G92	GND	L104
G93	GND	L105
G94	GND	L106
G95	GND	L107
G96	GND	L108
G97	GND	L109
G98	GND	L110
G99	GND	L111
G100	GND	L112
G101	GND	L113
G102	GND	L114
G103	GND	L115
G104	GND	L116
G105	GND	L117
G106	GND	L118
G107	GND	L119
G108	GND	L120
G109	GND	L121
G110	GND	L122
G111	GND	L123
G112	GND	L124
G113	GND	L125
G114	GND	L126
G115	GND	L127
G116	GND	L128
G117	GND	L129
G118	GND	L130
G119	GND	L131
G120	GND	L132
G121	GND	L133
G122	GND	L134
G123	GND	L135
G124	GND	L136
G125	GND	L137
G126	GND	L138
G127	GND	L139
G128	GND	L140
G129	GND	L141
G130	GND	L142
G131	GND	L143
G132	GND	L144
G133	GND	L145
G134	GND	L146
G135	GND	L147
G136	GND	L148
G137	GND	L149
G138	GND	L150
G139	GND	L151
G140	GND	L152
G141	GND	L153
G142	GND	L154
G143	GND	L155
G144	GND	L156
G145	GND	L157
G146	GND	L158
G147	GND	L159
G148	GND	L160
G149	GND	L161
G150	GND	L162
G151	GND	L163
G152	GND	L164
G153	GND	L165
G154	GND	L166
G155	GND	L167
G156	GND	L168
G157	GND	L169
G158	GND	L170
G159	GND	L171
G160	GND	L172
G161	GND	L173
G162	GND	L174
G163	GND	L175
G164	GND	L176
G165	GND	L177
G166	GND	L178
G167	GND	L179
G168	GND	L180
G169	GND	L181
G170	GND	L182
G171	GND	L183
G172	GND	L184
G173	GND	L185
G174	GND	L186
G175	GND	L187
G176	GND	L188
G177	GND	L189
G178	GND	L190
G179	GND	L191
G180	GND	L192
G181	GND	L193
G182	GND	L194
G183	GND	L195
G184	GND	L196
G185	GND	L197
G186	GND	L198
G187	GND	L199
G188	GND	L200
G189	GND	L201
G190	GND	L202
G191	GND	L203
G192	GND	L204
G193	GND	L205
G194	GND	L206
G195	GND	L207
G196	GND	L208
G197	GND	L209
G198	GND	L210
G199	GND	L211
G200	GND	L212
G201	GND	L213
G202	GND	L214
G203	GND	L215
G204	GND	L216
G205	GND	L217
G206	GND	L218
G207	GND	L219
G208	GND	L220
G209	GND	L221
G210	GND	L222
G211	GND	L223
G212	GND	L224
G213	GND	L225
G214	GND	L226
G215	GND	L227
G216	GND	L228
G217	GND	L229
G218	GND	L230
G219	GND	L231
G220	GND	L232
G221	GND	L233
G222	GND	L234
G223	GND	L235
G224	GND	L236
G225	GND	L237
G226	GND	L238
G227	GND	L239
G228	GND	L240
G229	GND	L241
G230	GND	L242
G231	GND	L243
G232	GND	L244
G233	GND	L245
G234	GND	L246
G235	GND	L247
G236	GND	L248
G237	GND	L249
G238	GND	L250
G239	GND	L251
G240	GND	L252
G241	GND	L253
G242	GND	L254
G243	GND	L255
G244	GND	L256
G245	GND	L257
G246	GND	L258
G247	GND	L259
G248	GND	L260
G249	GND	L261
G250	GND	L262
G251	GND	L263
G252	GND	L264
G253	GND	L265
G254	GND	L266
G255	GND	L267
G256	GND	L268
G257	GND	L269
G258	GND	L270
G259	GND	L271
G260	GND	L272
G261	GND	L273
G262	GND	L274
G263	GND	L275
G264	GND	L276
G265	GND	L277
G266	GND	L278
G267	GND	L279
G268	GND	L280
G269	GND	L281
G270	GND	L282
G271	GND	L283
G272	GND	L284
G273	GND	L285
G274	GND	L286
G275	GND	L287
G276	GND	L288
G277	GND	L289
G278	GND	L290
G279	GND	L291
G280	GND	L292
G281	GND	L293
G282	GND	L294
G283	GND	L295
G284	GND	L296
G285	GND	L297
G286	GND	L298
G287	GND	L299
G288	GND	L300
G289	GND	L301
G290	GND	L302
G291	GND	L303
G292	GND	L304
G293	GND	L305
G294	GND	L306
G295	GND	L307
G296	GND	L308
G297	GND	L309
G298	GND	L310
G299	GND	L311
G300	GND	L312
G301	GND	L313
G302	GND	L314
G303	GND	L315
G304	GND	L316
G305	GND	L317
G306	GND	L318
G307	GND	L319
G308	GND	L320
G309	GND	L321
G310	GND	L322
G311	GND	L323
G312	GND	L324
G313	GND	L325
G314	GND	L326
G315	GND	L327
G316	GND	L328
G317	GND	L329
G318	GND	L330
G319	GND	L331
G320	GND	L332
G321	GND	L333
G322	GND	L334
G323	GND	L335
G324	GND	L336
G325	GND	L337
G326	GND	L338
G327	GND	L339
G328	GND	L340
G329	GND	L341
G330	GND	L342
G331	GND	L343
G332	GND	L344
G333	GND	L345
G334	GND	L346
G335	GND	L347
G336	GND	L348
G337	GND	L349
G338	GND	L350
G339	GND	L351
G340	GND	L352
G341	GND	L353
G342	GND	L354
G343	GND	L355
G344	GND	L356
G345	GND	L357
G346	GND	L358
G347	GND	L359
G348	GND	L360
G349	GND	L361
G350	GND	L362
G351	GND	L363
G352	GND	L364
G353	GND	L365
G354	GND	L366
G355	GND	L367
G356	GND	L368
G357	GND	L369
G358	GND	L370
G359	GND	L371
G360	GND	L372
G361	GND	L373
G362	GND	L374
G363	GND	L375
G364	GND	L376
G365	GND	L377
G366	GND	L378
G367	GND	L379
G368	GND	L380
G369	GND	L381
G370	GND	L382
G371	GND	L383
G372	GND	L384
G373	GND	L385
G374	GND	L386
G375	GND	L387
G376	GND	L388
G377	GND	L389
G378	GND	L390
G379	GND	L391
G380	GND	L392
G381	GND	L393
G382	GND	L394
G383	GND	L395
G384	GND	L396
G385	GND	L397
G386	GND	L398
G387	GND	L399
G388	GND	L400
G389	GND	L401
G390	GND	L402
G391	GND	L403
G392	GND	L404
G393	GND	L405
G394	GND	L406
G395	GND	L407
G396	GND	L408
G397	GND	L409
G398	GND	L410
G399	GND	L411
G400	GND	L412
G401	GND	L413
G402	GND	L414
G403	GND	L415
G404	GND	L416
G405	GND	L417
G406	GND	L418
G407	GND	L419
G408	GND	L420
G409	GND	L421
G410	GND	L422
G411	GND	L423
G412	GND	L424
G413	GND	L425
G414	GND	L426
G415	GND	L427
G416		

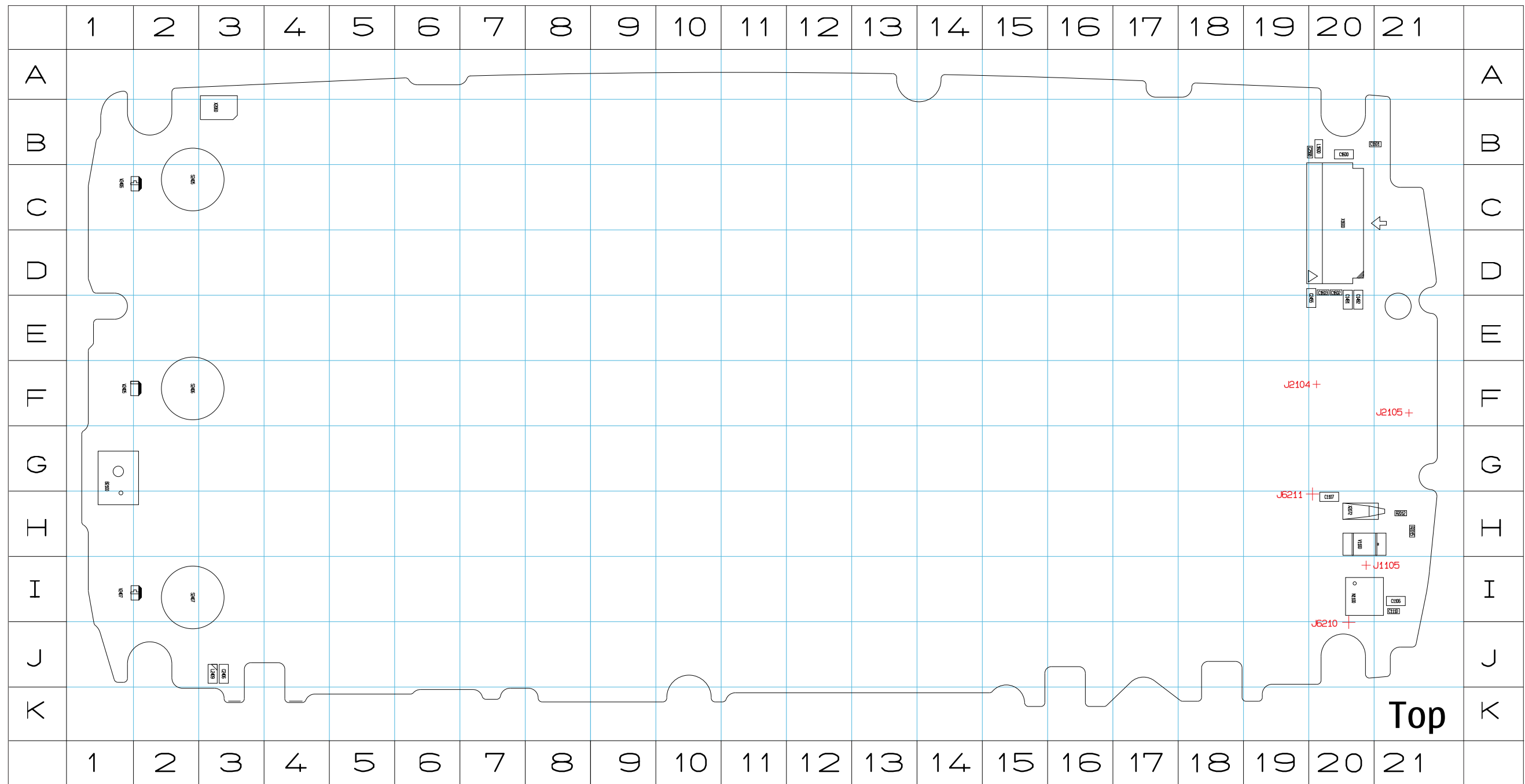

B	C1600	B20	L1600	B20	V1100	H20
B2100	G1	C1601	B21	L2409	J3	V2405
C	C1602	D20	N		V2406	C1
C1106	I21	C1603	D20	N1100	I20	V2407
C1107	H20	C2406	J3	R		X
C1110	I21	C2455	E20	R2012	H21	X1600
C1481	E20	C2568	B20	R2015	H21	X2060
C1482	E20	L		V		X2072

