

Service Schematics



Introduction

Important:

This document is intended for use by authorized service centers only.

“Service Schematics” was created with focus on customer care.
The purpose of this document is to provide further technical repair information for NOKIA mobile phones on Level 3/4 service activities.
It contains additional information such as e.g. “Component finder”.

Saving process time and improving the repair quality is the aim of this document.
It is to be used additionally to the service manual and other training or service information such as Service Bulletins.

While every endeavour has been made to ensure the accuracy of this document, some errors may exist. If the reader finds any errors, NOKIA should be notified in writing.

Please send E-Mail to: TrainingAndVendor.Development@nokia.com

RM-210

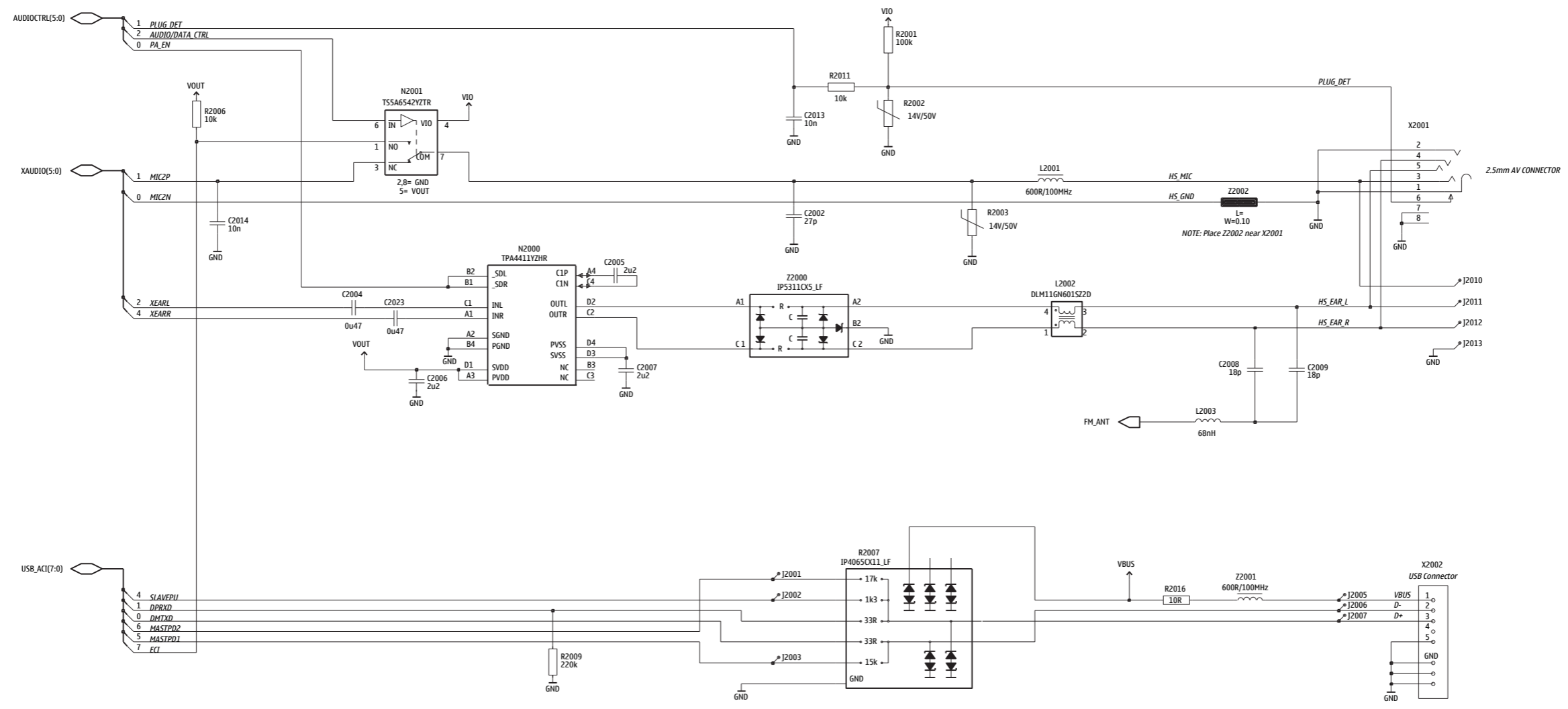

Table of contents

Frontpage	1
AV connector	2
AVILMA & BETTY	3
RAPSTACK & micro SD card	4
BTFM module	5
B2B & user interface	6
RF part	7
B2B connector / upper block	8
HWA & camera / upper block	9
Component finder / upper block	10
Component finder / lower bock	11

Copyright © NOKIA

This material, including documentation and any related computer programs is protected by copyright, controlled by NOKIA. All rights are reserved. Copying, including reproducing, modifying, storing, adapting or translating any or all of this material requires the prior written consent of NOKIA. This material also contains confidential information, which may not be disclosed to others without the prior written consent of NOKIA.



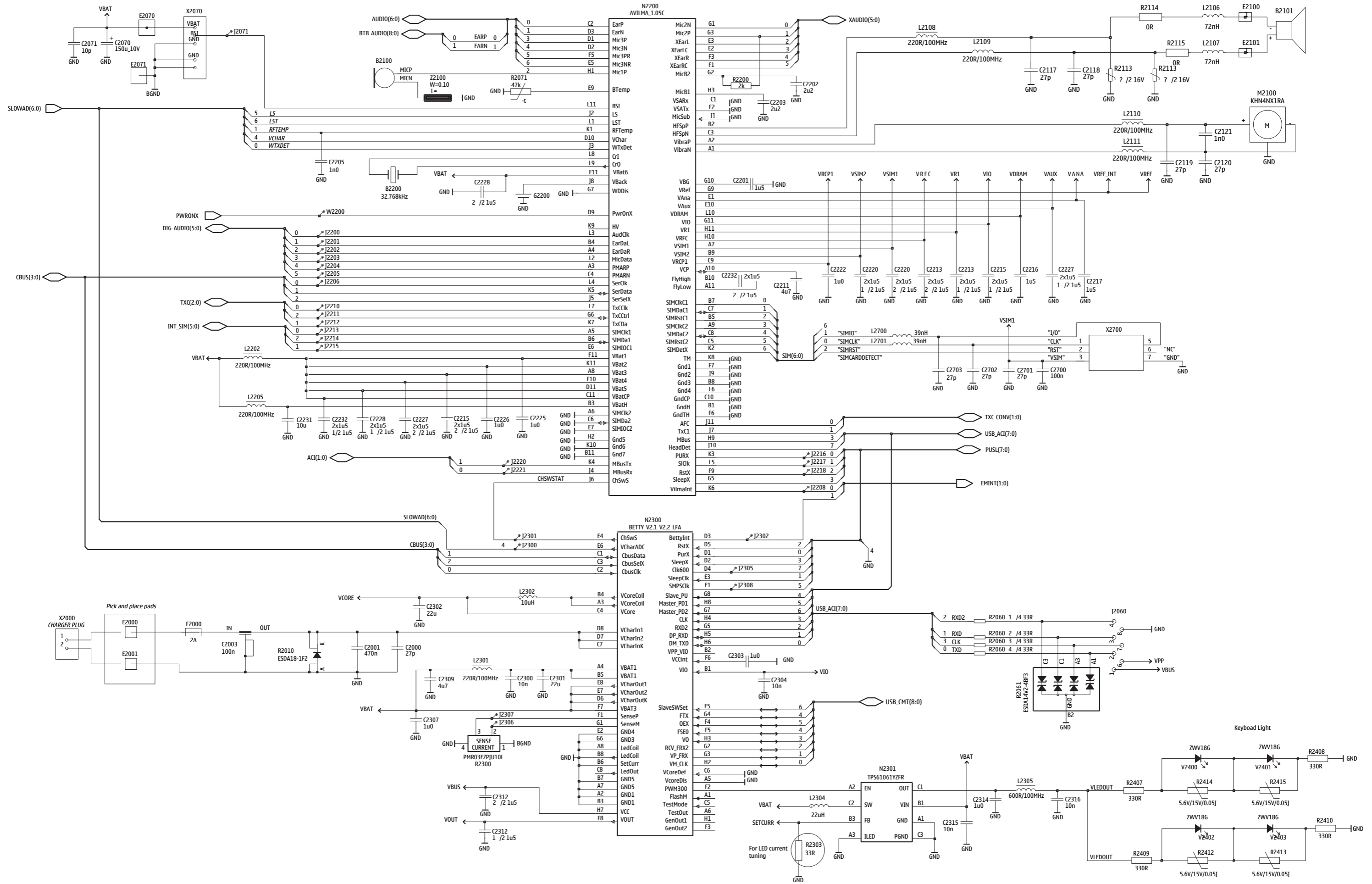

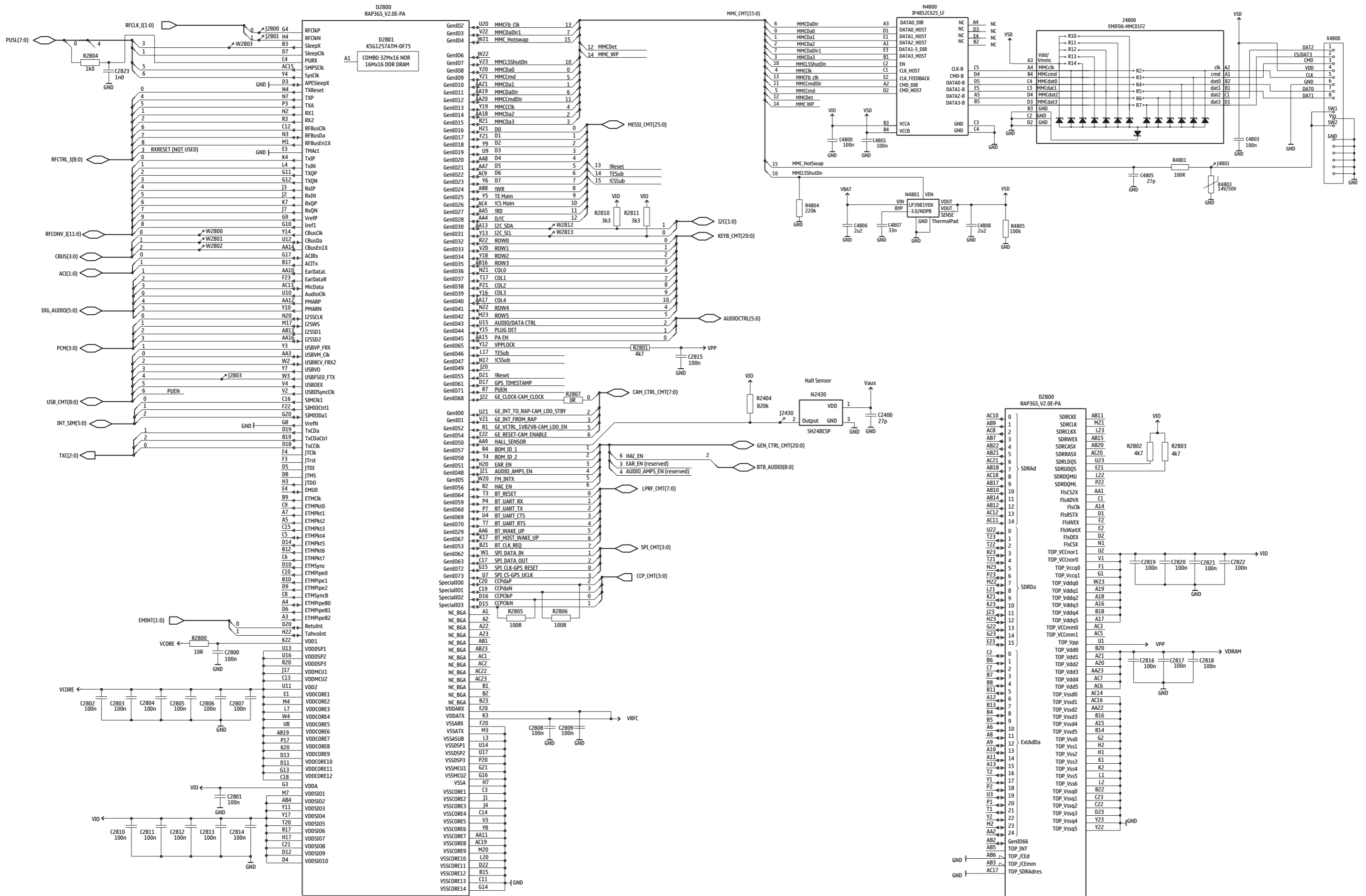

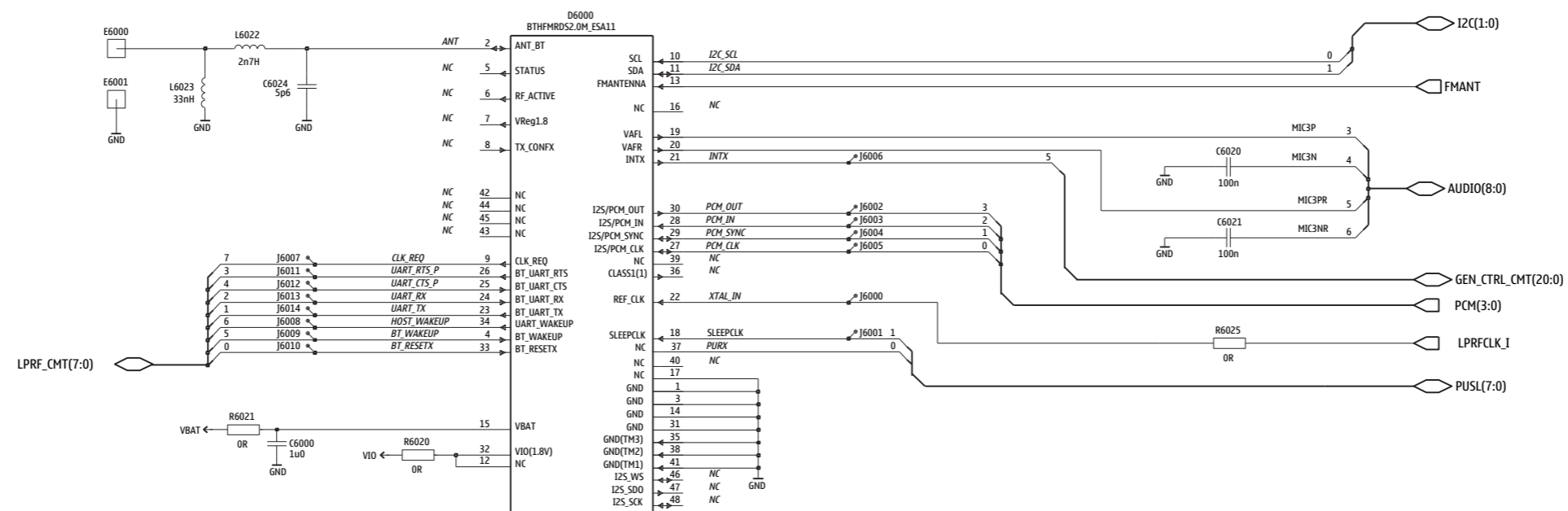

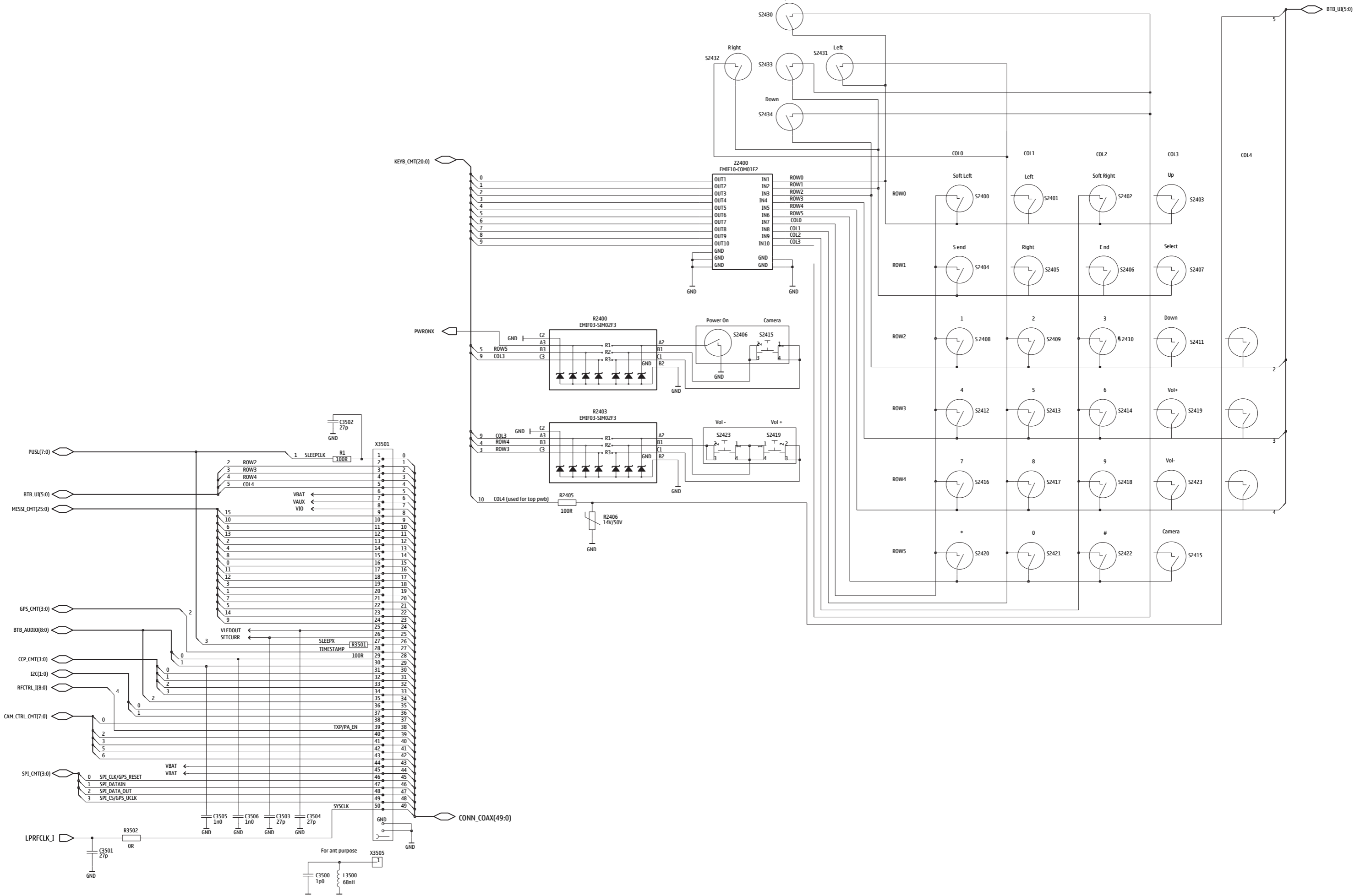

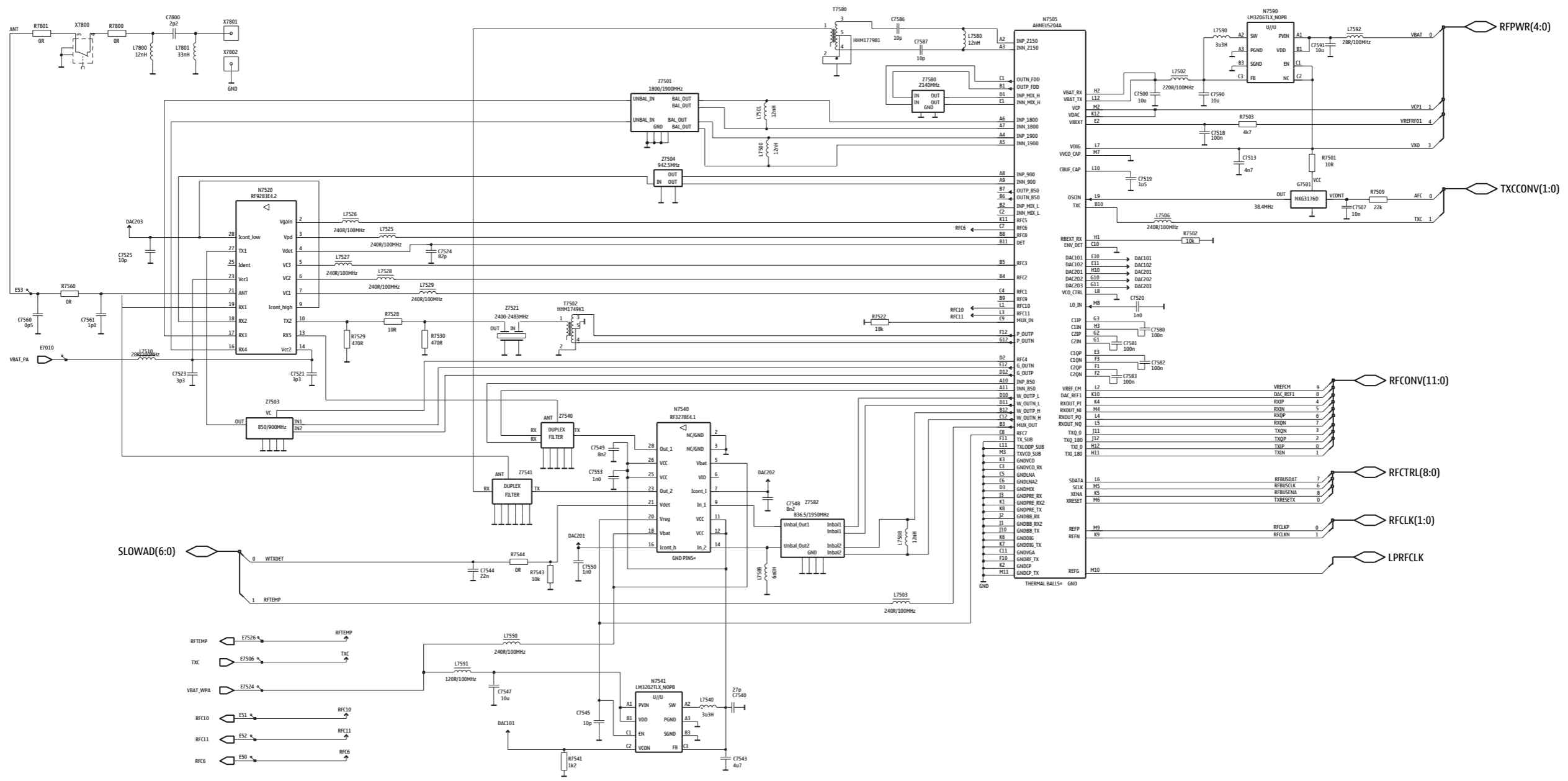

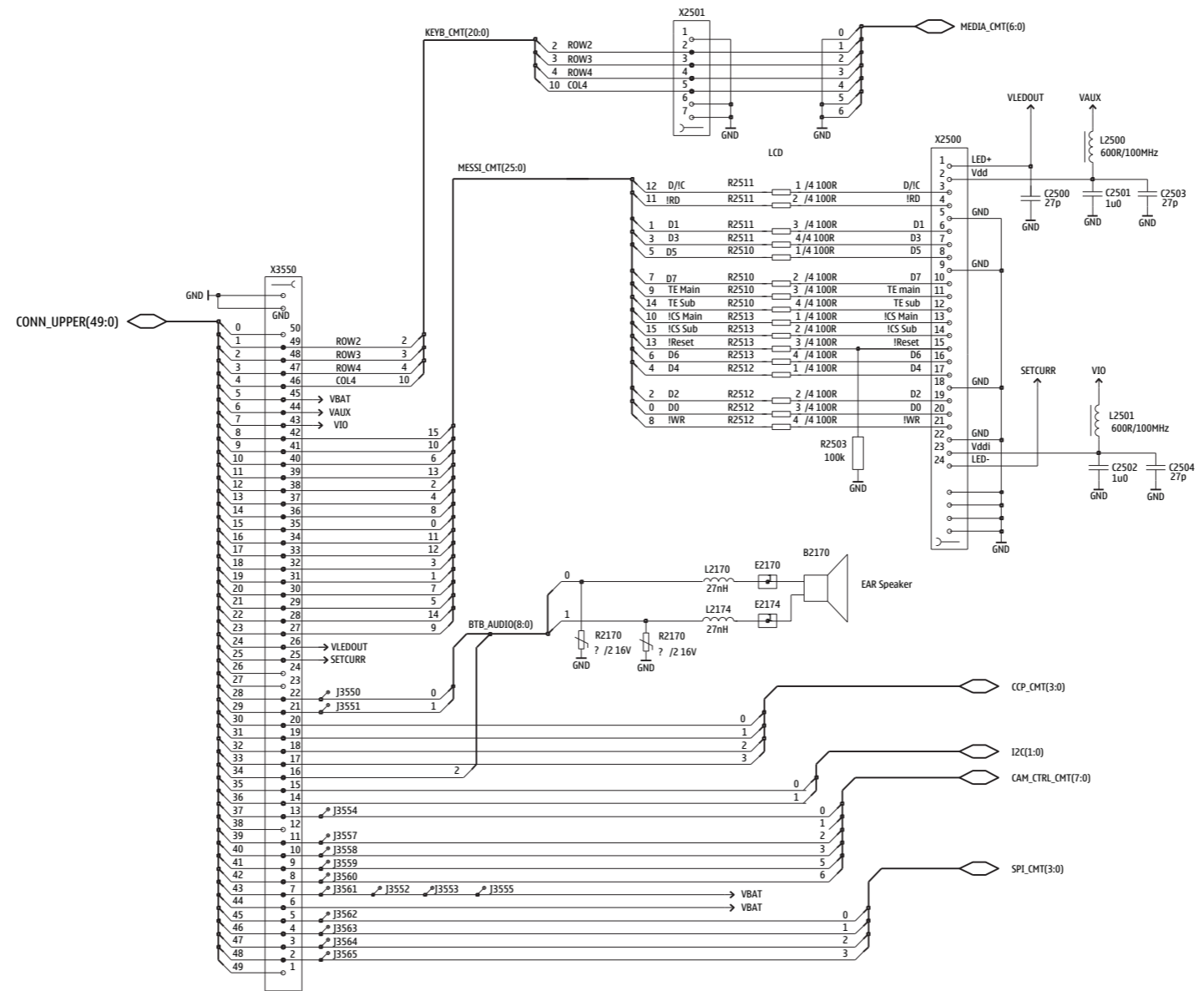

B	C3100	H3	E7552	H3	J2305	18	L7592	G5	R7543	F9	
B2200	16	C3500	R1	E7554	H3	J2306	19	L7800	D5	R7544	F9
C	C3501	N6	E7556	H3	J2307	19	L7801	D5	R7560	F7	
C2000	Q4	C3502	N2	E7558	G2	J2308	19	M	R7800	E5	
C2001	Q4	C3503	N4	E7560	F2	J2430	Q3	M2100	Q5	R7801	E6
C2002	Q7	C3504	N4	E7562	F2	J2800	I2	N	S		
C2003	Q4	C3505	N5	E7564	G2	J2801	I2	N2000	P7	S2415	O9
C2004	Q7	C3506	N5	E7566	F2	J2803	I8	N2001	Q8	S2419	K9
C2005	P6	C4800	L5	E7568	F2	J3100	N6	N2200	J6	S2423	M9
C2006	P6	C4801	L5	E7570	G2	J3101	M7	N2300	I8	T	
C2007	Q6	C4803	L5	E7572	G2	J3102	N7	N2301	K7	T7502	H6
C2008	Q6	C4805	M5	E7574	G2	J3103	M6	N2430	P2	T7580	F5
C2009	Q7	C4806	N9	E7814	E8	J3104	N7	N4800	L5	V	
C2013	Q8	C4807	N9	E7900	H5	J3105	N6	N4801	N8	V2400	I7
C2014	Q8	C4808	M5	E7901	E2	J3110	M7	N7505	F3	V2401	I4
C2023	P7	C6000	P9	E7902	H3	J3111	M6	N7520	G6	V2402	D7
C2070	F2	C6020	O8	E7903	F2	J3112	L7	N7540	G9	V2403	D4
C2071	E2	C6021	O8	E7904	F2	J3113	L6	N7541	F9	W	
C2117	L8	C6024	Q9	E7905	F2	J3114	L7	N7590	G5	W2200	M9
C2118	L8	C7500	G3	E7906	G2	J3115	M6	R	W2800	K9	
C2119	Q3	C7507	G4	E7907	H3	J3116	M7	R1	N2	W2801	I9
C2120	Q3	C7513	F3	E7908	H3	J3117	L7	R2001	Q8	W2802	I9
C2121	Q3	C7518	F4	E7909	H3	J3120	L6	R2002	Q8	W2803	I2
C2201	I5	C7519	F3	E7910	H3	J4801	N5	R2003	Q7	W2812	K4
C2202	I7	C7520	F3	E7911	H4	J6000	O8	R2006	Q8	W2813	K4
C2203	I7	C7521	F7	E7912	E4	J6001	O9	R2007	Q5	X	
C2205	I7	C7523	H7	E7913	E2	J6002	P7	R2009	Q5	X2001	R8
C2211	K5	C7524	F5	E7914	H4	J6003	O7	R2010	Q4	X2002	R5
C2213	I5	C7525	F6	E7915	G2	J6004	O7	R2011	Q8	X2061	Q5
C2215	I5	C7540	F8	E7916	F2	J6005	O7	R2016	Q6	X2070	D4
C2216	I5	C7543	F8	E7917	F2	J6006	O8	R2060	H9	X2700	M8
C2217	I7	C7544	F9	E7918	F2	J6007	O9	R2061	L7	X3501	O4
C2220	K6	C7545	F9	E7920	F2	J6008	P7	R2071	N5	X3505	R2
C2222	K6	C7547	F9	E7921	G2	J6009	P7	R2113	E8	X4800	M3
C2225	H5	C7548	F9	E7922	G2	J6010	P7	R2114	E8	X7800	E5
C2226	K6	C7549	G8	E7923	G2	J6011	O7	R2115	E7	X7801	C4
C2227	I5	C7550	F9	E7924	E8	J6012	O8	R2200	J7	X7802	C3
C2228	I5	C7553	G8	E7925	E3	J6013	O8	R2300	F2	Z	
C2231	K7	C7560	F7	E7926	E9	J6014	O8	R2303	K7	Z2000	Q7
C2232	K5	C7561	F7	E7927	H7	J6020	O8	R2400	N9	Z2001	Q5
C2300	J8	C7580	F3	F	J6021	O8	R2403	L9	Z2002	R8	
C2301	I9	C7581	F3	F2000	Q4	L	R2404	Q3	Z2100	J7	
C2302	I9	C7582	F2	G	L2001	Q7	R2405	K4	Z2400	N7	
C2303	H8	C7583	F3	G2200	I7	L2002	Q7	R2406	K4	Z4800	M5
C2304	I9	C7586	F4	G7501	H3	L2003	Q8	R2407	I7	Z7501	F5
C2307	I7	C7587	F4	J	L2106	C8	R2408	I4	Z7503	G5	
C2309	K8	C7590	H5	J2001	Q6	L2107	D8	R2409	D7	Z7504	G4
C2312	H7	C7591	G5	J2002	Q6	L2108	L7	R2410	D4	Z7521	H6
C2314	I7	C7800	D5	J2003	Q6	L2109	L8	R2412	D7	Z7540	G8
C2315	K7	D	J2005	R5	L2110	Q3	R2413	D4	Z7541	G8	
C2316	I7	D2800	J3	J2006	R5	L2111	Q3	R2414	I7	Z7580	F4
C2400	Q3	D2801	J3	J2007	R6	L2202	K6	R2415	I4	Z7582	H4
C2700	L9	D6000	P8	J2010	R8	L2205	K6	R2800	J5		
C2701	L9	E	J2011	R8	L2301	K8	R2801	K3			
C2702	L5	E2000	S3	J2012	R7	L2302	K8	R2802	K4		
C2703	L6	E2001	S3	J2013	R7	L2304	J8	R2803	I5		
C2800	I5	E2070	D2	J2060	M6	L2305	J7	R2804	H2		
C2801	I2	E2071	E2	J2071	E2	L2700	L6	R2805	H4		
C2802	K4	E2100	B8	J2200	I6	L2701	L6	R2806	H4		
C2803	K3	E2101	D8	J2201	J7	L3500	R1	R2807	I5		
C2804	J2	E50	G4	J2202	I5	L6022	P9	R2810	P9		
C2805	J5	E51	F2	J2203	I6	L6023	P9	R2811	P9		
C2806	I2	E52	F2	J2204	K6	L7500	F4	R3501	N4		
C2807	H3	E53	F7	J2205	J7	L7501	F4	R3502	N6		
C2808	I2	E6000	Q9	J2206	I9	L7502	H4	R4801	N5		
C2809	I5	E6001	Q9	J2208	I6	L7503	F4	R4803	N5		
C2810	H4	E7010	H7	J2210	I6	L7506	H3	R4804	N9		
C2811	K2	E7506	H4	J2211	J7	L7510	H7	R4805	M5		
C2812	H3	E7524	E9	J2212	I6	L7525	F5	R6020	P7		
C2813	H5	E7526	E3	J2213	K6	L7526	F5	R6021	O9		
C2814	K3	E7528	H5	J2214	I5	L7527	F6	R6025	O8		
C2815	K2	E7530	E2	J2215	J7	L7528	F6	R7501	G3		
C2816	K5	E7534	H3	J2216	I9	L7529	F7	R7502	F3		
C2817	K3	E7536	E4	J2217	I8	L7540	F8	R7503	F4		
C2818	H4	E7540	H4	J2218	J8	L7550	F9	R7509	G3		
C2819	J2	E7542	F2	J2220	I6	L7580	F4	R7522	G4		
C2820	K2	E7544	F2	J2221	I6	L7588	G4	R7528	H6		
C2821	H3	E7546	F2	J2300	J7	L7589	H4	R7529	H6		
C2822	I5	E7548	F2	J2301	I8	L7590	H5	R7530	H6		
C2823	H2	E7550	H3	J2302	I8	L7591	F9	R7541	F9		

