

Service Schematics

NOKIA

6303

CLASSIC

RM-443

Introduction

Important:

This document is intended for use by authorized service centers only.

“Service Schematics” was created with focus on customer care.
The purpose of this document is to provide further technical repair information for NOKIA mobile phones on Level 3/4 service activities.
It contains additional information such as e.g. “Component finder”.

Saving process time and improving the repair quality is the aim of this document.
It is to be used additionally to the service manual and other training or service information such as Service Bulletins.

While every endeavour has been made to ensure the accuracy of this document, some errors may exist. If the reader finds any errors, NOKIA should be notified in writing.

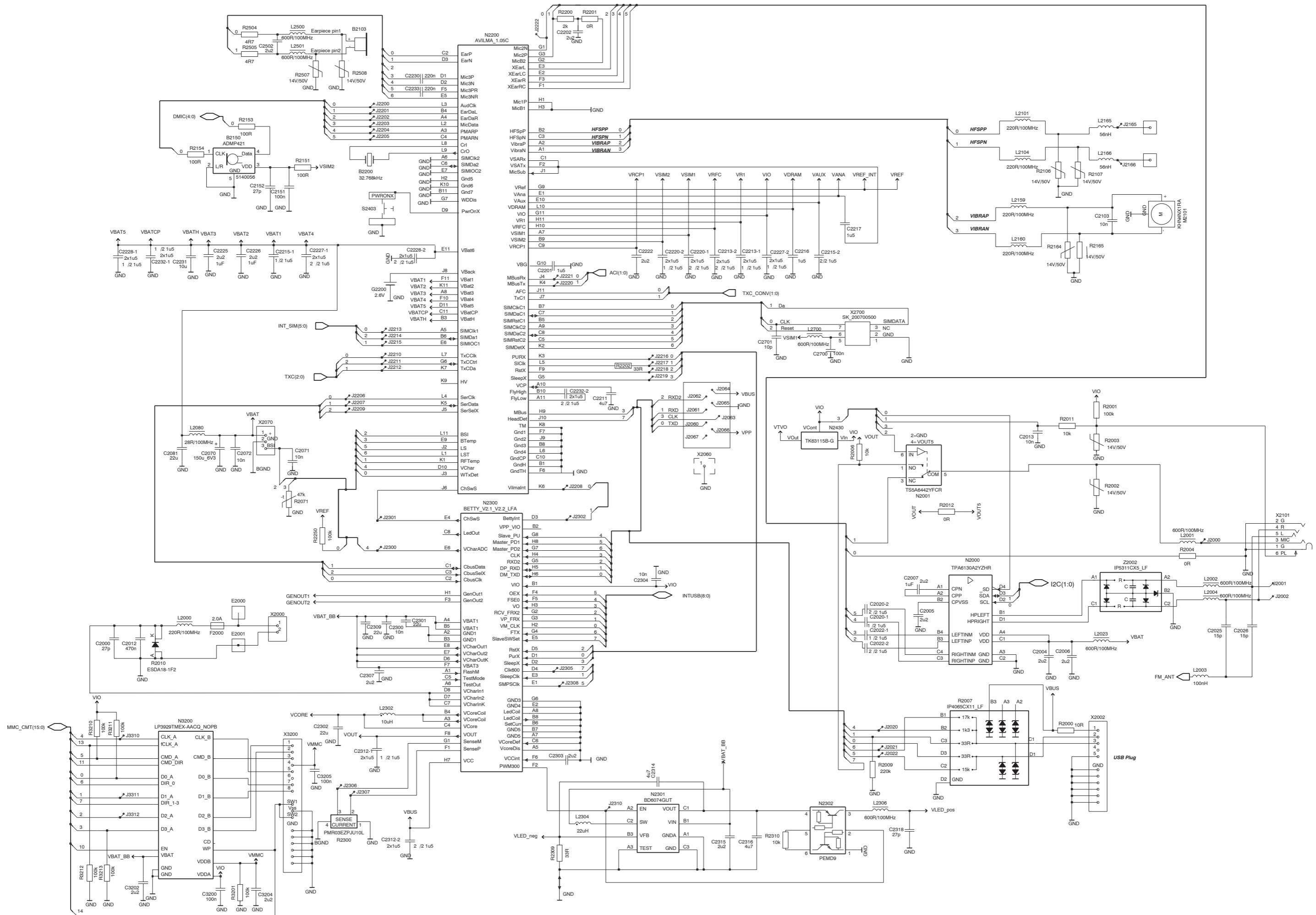
Please send E-Mail to: TrainingAndVendor.Development@nokia.com

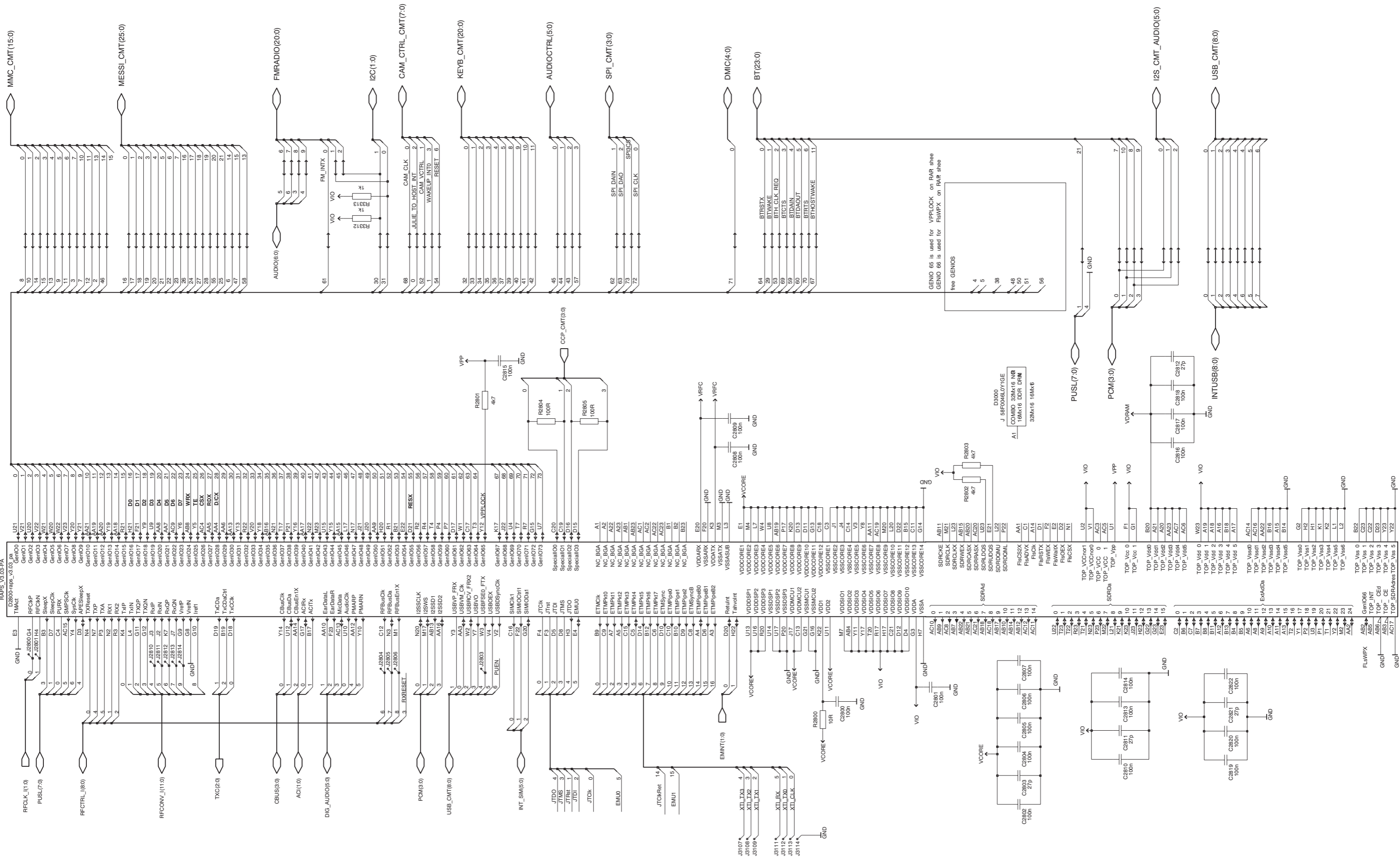


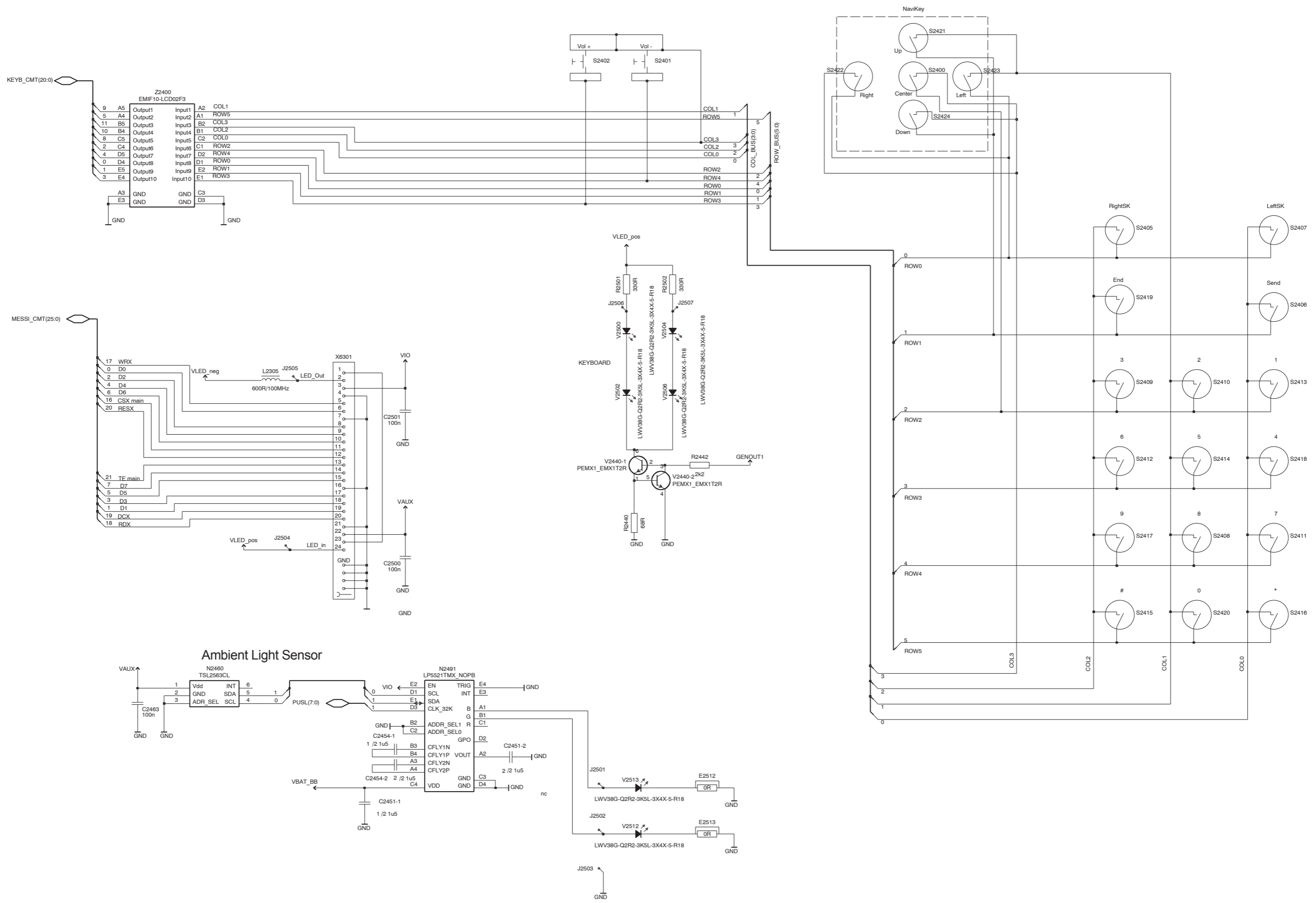
Table of contents	
Frontpage	1
AVilma - Betty - SD card	2
RAPStack	3
User Interface	4
Camera	5
Bluetooth - FM Radio	6
RF - part	7
Component finder	8

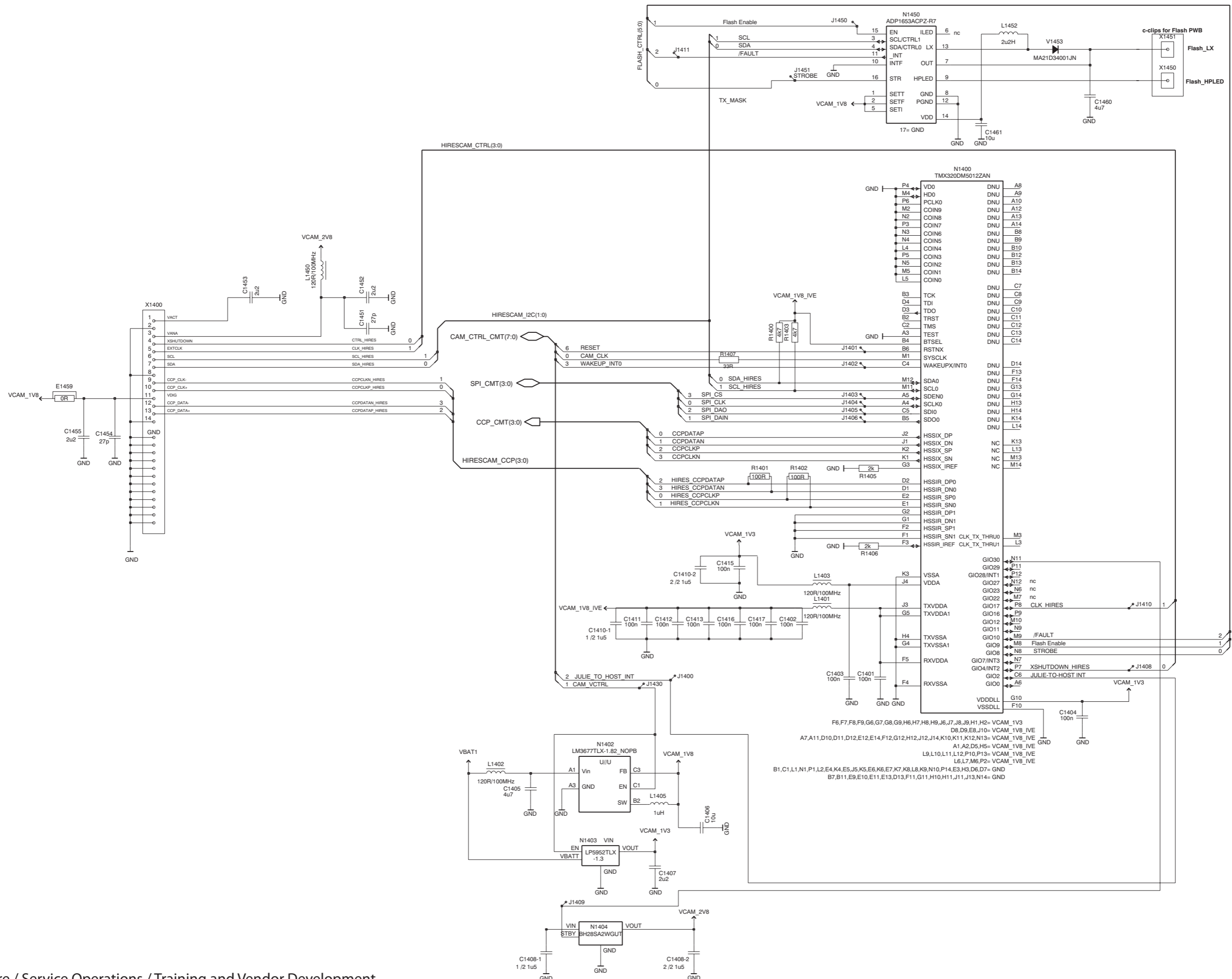
Copyright © NOKIA

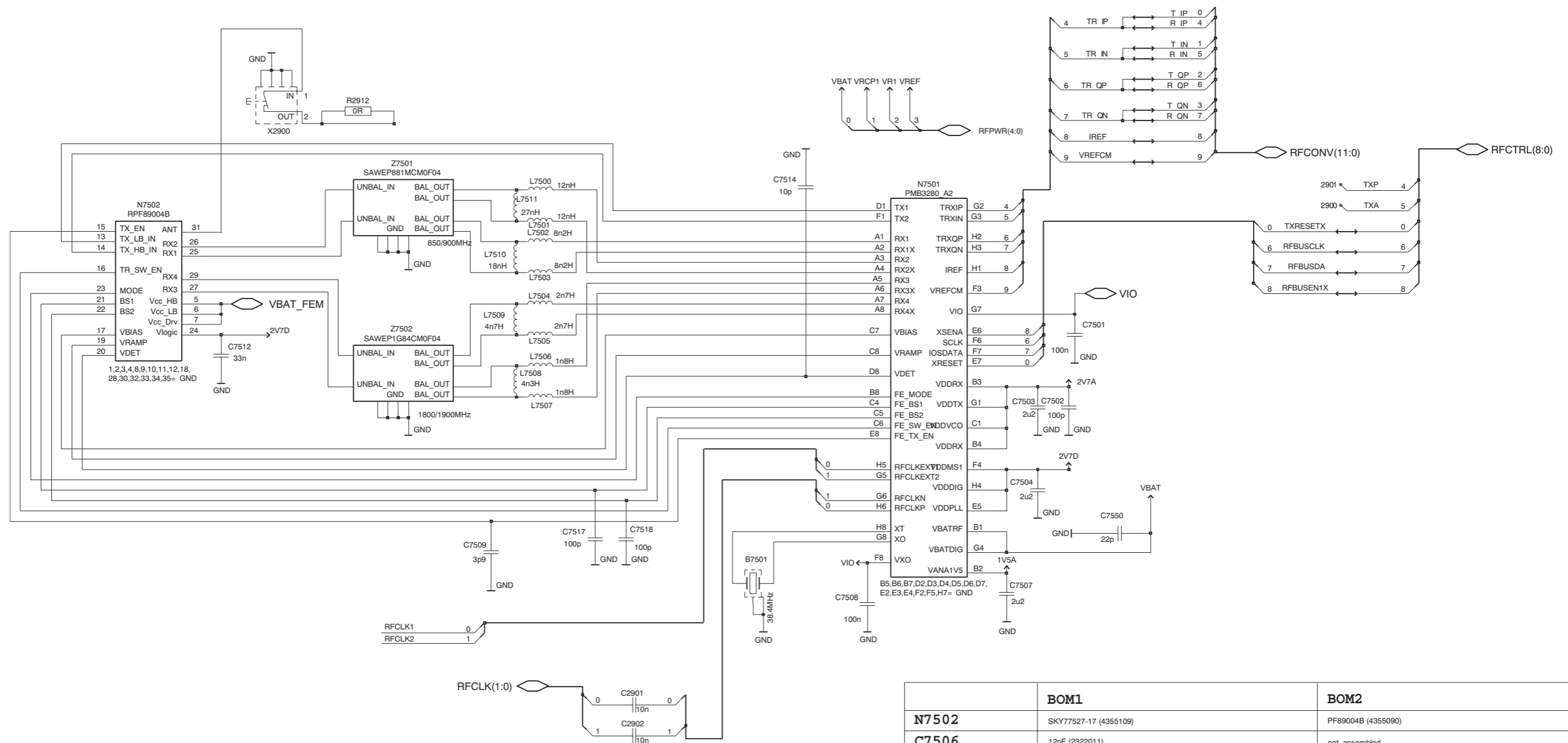
This material, including documentation and any related computer programs is protected by copyright, controlled by NOKIA. All rights are reserved. Copying, including reproducing, modifying, storing, adapting or translating any or all of this material requires the prior written consent of NOKIA. This material also contains confidential information, which may not be disclosed to others without the prior written consent of NOKIA.





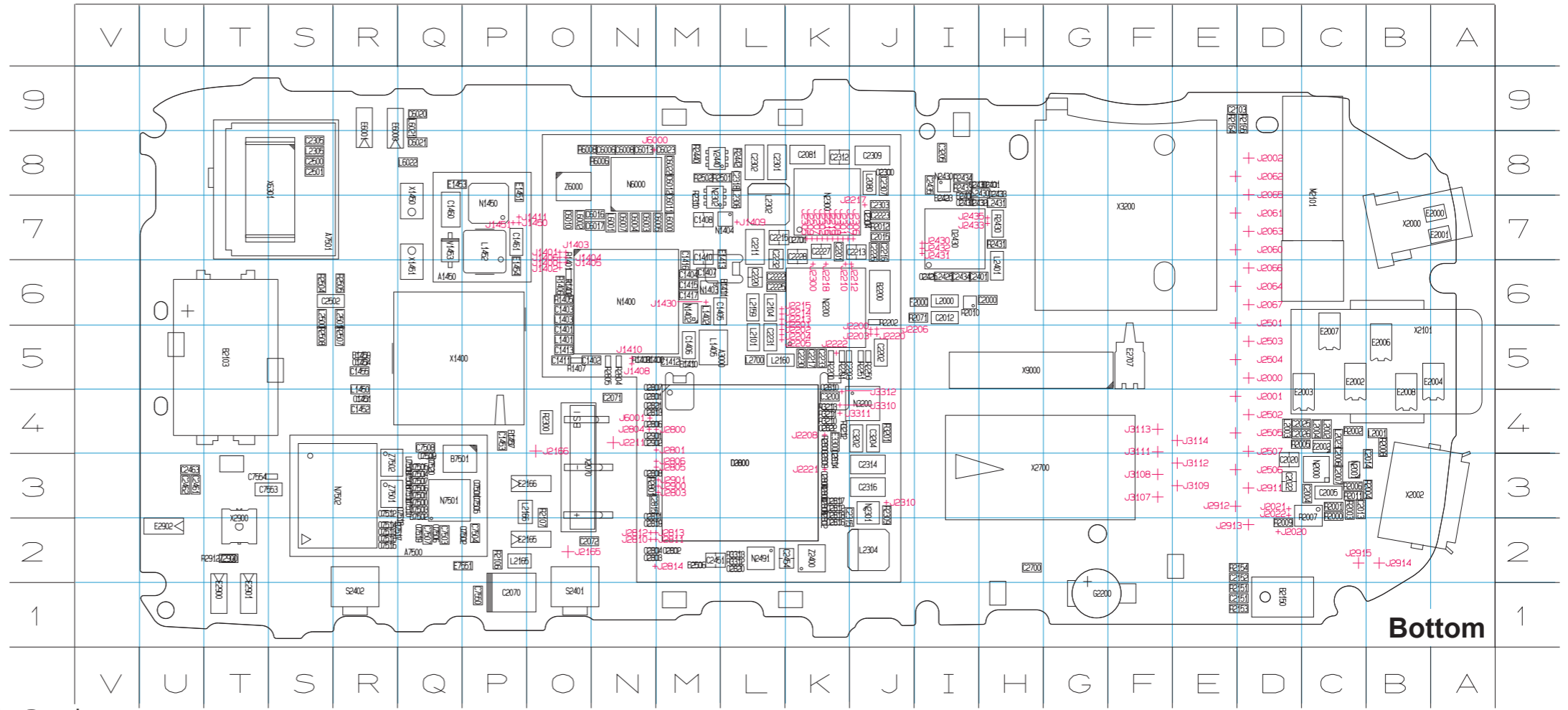
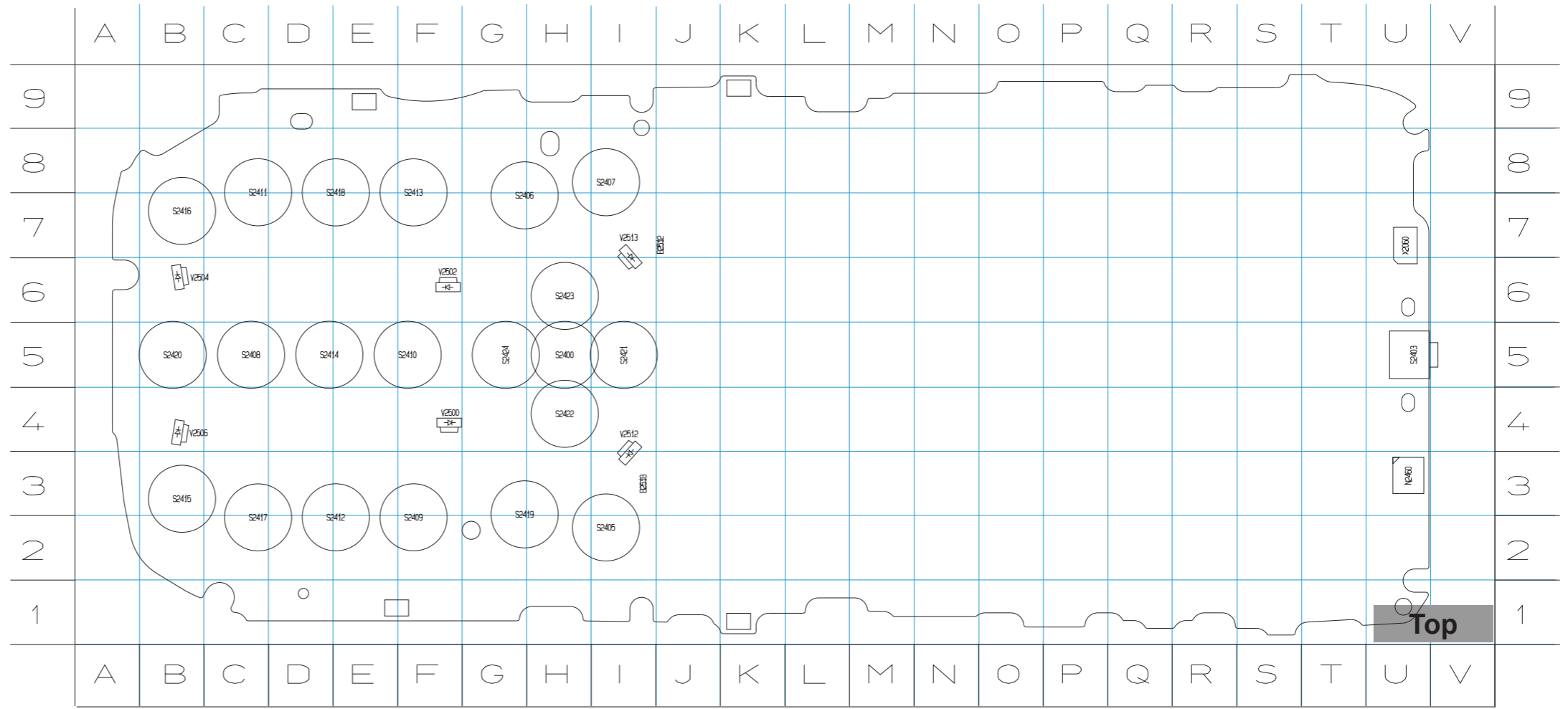






	BOM1	BOM2
N7502	SKY77527-17 (4355109)	PF89004B (4355090)
C7506	12pF (2322011)	not_assembled
C7509	4,7 pF (2322051)	3,9 pF (2351070)
C7514	not_assembled	10pF (2320121)
C7516	18pF (2351107)	not_assembled
C7517	not_assembled	100pF (2351160)
C7518	not_assembled	100pF (2351160)
Z7501	Epcos B9304/LM90B (4511639)	Murata SAWEP881MCM0F04R13 (4511605)
Z7502	Epcos B9305/LM91P (4511821)	Murata SAWEP1G84CM0F04R13 (4511597)
L7500, L7501	10 nH (3640210)	12 nH (3640205)
L7511	27 nH (3640235)	27 nH (3640235)
L7502, L7503	8.2 nH (3640253)	8,2 nH (3640253)
L7510	18 nH (3640234)	18 nH (3640234)
L7504, L7505	2,7 nH (3640256)	2,7 nH (3640256)
L7509	3,9 nH (3640196)	4,7 nH (3640197)
L7506, L7507	1,5 nH (3640194)	1,8 nH (3640195)
L7508	4,7 nH (3640197)	4,3 nH (3640233)

A	C2223	J 7	C2901	N 4	E2166	O 3	L7508	Q 3	R2431	H 7	
A1450	P 7	C2225	L 6	C2902	N 4	E2700	I 9	L7509	Q 3	R2433	I 8
A3000	L 5	C2226	J 7	C3200	K 4	E2701	H 1	L7510	Q 3	R2434	I 8
A7500	R 3	C2227	K 7	C3202	J 4	E2702	M 9	L7511	Q 3	R2440	M 8
A7501	S 8	C2228	K 7	C3204	J 4	E2703	K 1	M	R2442	L 8	
B	C2230	K 5	C3205	I 8	E2704	M 1	M2101	C 8	R2501	L 8	
B2103	T 5	C2231	L 5	C6003	N 7	E2705	E 2	N	R2502	M 8	
B2150	D 1	C2232	L 7	C6004	N 7	E2706	K 9	N1400	N 6	R2504	S 6
B2200	J 6	C2233	K 5	C6005	M 7	E2707	F 5	N1402	M 6	R2505	R 6
B7501	Q 3	C2300	J 8	C6006	N 8	E2708	T 3	N1403	M 6	R2507	R 5
C	C2301	L 8	C6007	N 7	E2900	T 1	N1404	L 7	R2508	S 5	
C1401	O 5	C2302	L 8	C6008	N 8	E2901	T 1	N1450	P 7	R2800	K 3
C1402	N 5	C2303	J 7	C6010	O 7	E2902	U 2	N2000	C 3	R2801	N 3
C1403	O 6	C2304	J 7	C6011	M 7	E6000	R 9	N2001	C 3	R2802	K 2
C1404	M 6	C2305	S 8	C6012	M 8	E6001	R 9	N2200	K 6	R2803	K 4
C1405	L 6	C2307	J 8	C6013	N 8	F	N2300	K 7	R2804	N 5	
C1406	M 5	C2309	J 8	C6016	N 7	F2000	I 6	N2301	J 3	R2805	N 5
C1407	M 6	C2312	K 8	C6017	N 7	G	N2302	M 7	R2912	T 2	
C1408	M 7	C2314	J 3	C6020	Q 9	G2200	G 1	N2430	I 8	R3201	J 4
C1410	M 7	C2315	J 3	C6021	Q 8	L	N2460	U 3	R3210	K 4	
C1411	O 5	C2316	J 3	C6022	M 8	L1401	O 5	N2491	L 2	R3211	K 4
C1412	M 5	C2318	L 8	C6023	M 8	L1402	M 6	N3200	J 4	R3212	K 4
C1413	O 5	C2401	H 6	C7501	P 3	L1403	O 6	N6000	N 8	R3213	K 4
C1415	M 6	C2425	I 6	C7502	P 2	L1405	M 5	N7501	Q 3	R3312	L 2
C1416	M 6	C2430	H 8	C7503	Q 2	L1450	R 4	N7502	R 3	R3313	L 2
C1417	M 6	C2431	I 7	C7504	P 2	L1452	P 7	R	R6006	N 8	
C1451	R 4	C2432	H 7	C7505	P 3	L2000	I 6	R1400	N 5	R6008	O 8
C1452	R 4	C2433	H 8	C7506	Q 2	L2001	B 4	R1401	O 6	S	
C1453	P 4	C2434	I 6	C7507	Q 2	L2002	C 4	R1402	O 6	S2401	O 1
C1454	R 5	C2435	I 8	C7508	Q 4	L2003	D 4	R1403	N 5	S2402	R 1
C1455	R 5	C2451	M 2	C7509	Q 3	L2004	C 4	R1405	O 6	S2403	U 5
C1460	Q 7	C2454	K 2	C7512	R 3	L2023	C 4	R1406	O 6	V	
C1461	P 7	C2461	U 3	C7513	R 2	L2080	J 8	R1407	O 5	V1453	Q 7
C2000	H 6	C2462	U 3	C7514	R 2	L2101	L 5	R2000	C 3	V2440	M 8
C2004	C 3	C2463	U 3	C7515	R 2	L2104	L 6	R2001	C 3	V2500	F 4
C2005	C 3	C2500	S 8	C7516	R 2	L2159	L 6	R2002	C 4	V2502	F 6
C2006	C 3	C2501	S 8	C7517	Q 2	L2160	L 5	R2003	C 3	V2504	B 6
C2007	C 3	C2502	S 6	C7518	Q 3	L2165	P 2	R2004	B 3	V2506	B 4
C2012	I 6	C2700	H 2	C7519	Q 2	L2166	P 3	R2005	C 4	V2512	I 3
C2013	C 3	C2701	K 7	C7520	Q 3	L2302	L 7	R2006	C 3	V2513	I 7
C2014	B 3	C2800	K 3	C7550	P 1	L2304	J 2	R2007	C 3	X	
C2015	J 7	C2801	N 4	C7553	S 3	L2305	S 8	R2008	B 4	X1400	Q 5
C2020	D 3	C2802	M 2	C7554	S 3	L2306	L 7	R2009	D 2	X1450	Q 7
C2022	D 3	C2803	N 2	D	L2401	H 6	R2010	I 6	X1451	Q 6	
C2025	C 4	C2804	N 2	D2430	I 7	L2425	I 6	R2011	C 3	X2000	B 7
C2026	C 4	C2805	K 3	D2800	L 3	L2430	H 8	R2012	J 7	X2002	B 3
C2070	P 1	C2806	N 4	D3000	L 3	L2431	H 7	R2071	I 6	X2060	U 7
C2071	N 4	C2807	N 5	E	L2500	S 6	R2106	P 2	X2070	O 3	
C2072	O 2	C2808	N 3	E1000	E 9	L2501	R 6	R2107	O 3	X2101	B 5
C2081	K 8	C2809	K 3	E1001	K 9	L2700	L 5	R2151	D 1	X2700	H 3
C2103	D 9	C2810	K 5	E1003	E 1	L6000	M 7	R2153	D 1	X2900	T 2
C2151	D 1	C2811	N 3	E1004	K 1	L6001	N 7	R2154	D 2	X3200	F 7
C2152	D 2	C2812	K 3	E2000	A 7	L6002	O 7	R2164	E 9	X6301	S 8
C2201	K 7	C2813	N 4	E2001	A 7	L6021	Q 9	R2165	D 9	Z	
C2202	J 5	C2814	K 3	E2002	C 5	L6022	Q 8	R2200	K 5	Z2002	C 4
C2203	K 5	C2815	N 3	E2003	C 4	L7500	Q 3	R2201	K 5	Z2400	K 2
C2211	L 7	C2816	K 2	E2004	A 5	L7501	Q 3	R2202	J 6	Z2900	T 2
C2213	J 7	C2817	K 3	E2006	B 5	L7502	Q 3	R2250	J 5	Z6000	O 8
C2215	L 7	C2818	K 3	E2007	C 5	L7503	Q 3	R2251	J 5	Z7501	R 3
C2216	J 7	C2819	N 2	E2008	B 4	L7504	Q 3	R2300	O 4	Z7502	R 3
C2217	K 5	C2820	L 2	E2100	U 5	L7505	Q 3	R2309	J 3		
C2220	L 6	C2821	N 4	E2101	S 5	L7506	Q 3	R2310	M 7		
C2222	L 6	C2822	K 4	E2165	O 2	L7507	Q 3	R2430	H 7		



www.s-manuals.com