

Service Schematics

NOKIA 6555

RM-271

RM-276 / RM-289

Introduction

Important:

This document is intended for use by authorized service centers only.

“Service Schematics” was created with focus on customer care.
The purpose of this document is to provide further technical repair information for NOKIA mobile phones on Level 3/4 service activities.
It contains additional information such as e.g. “Component finder”.

Saving process time and improving the repair quality is the aim of this document.
It is to be used additionally to the service manual and other training or service information such as Service Bulletins.

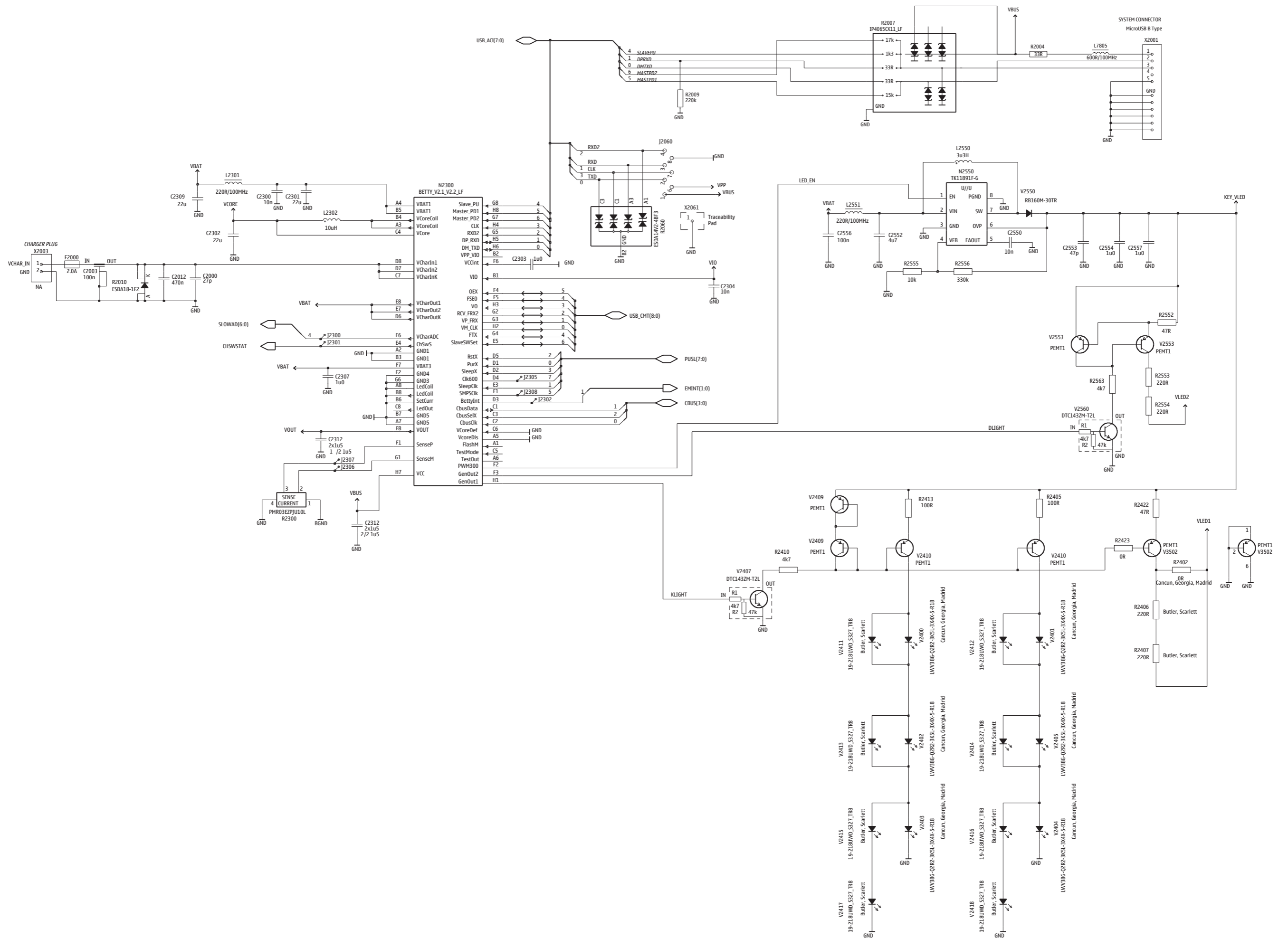
While every endeavour has been made to ensure the accuracy of this document, some errors may exist. If the reader finds any errors, NOKIA should be notified in writing.

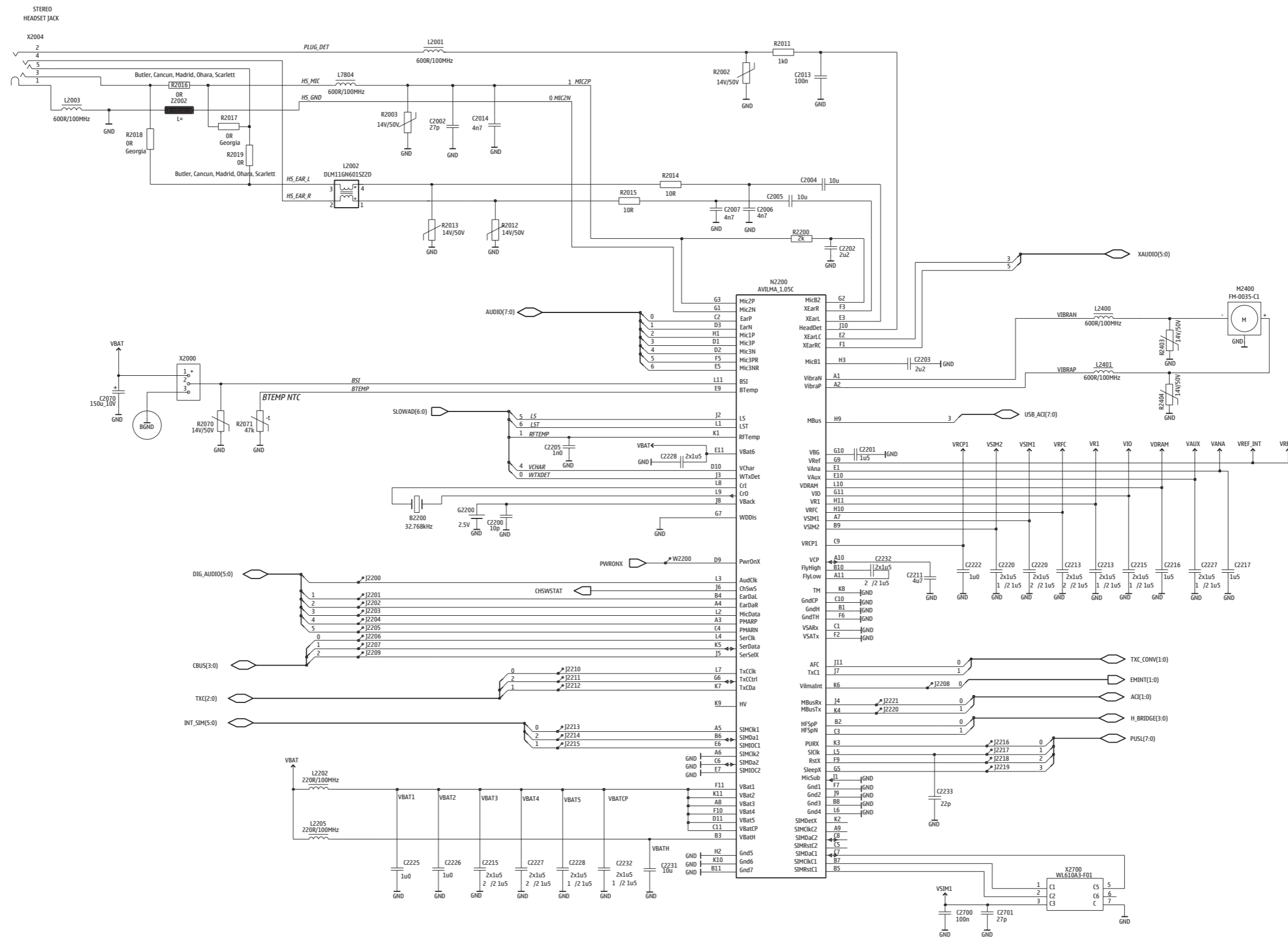
Please send E-Mail to: TrainingAndVendor.Development@nokia.com

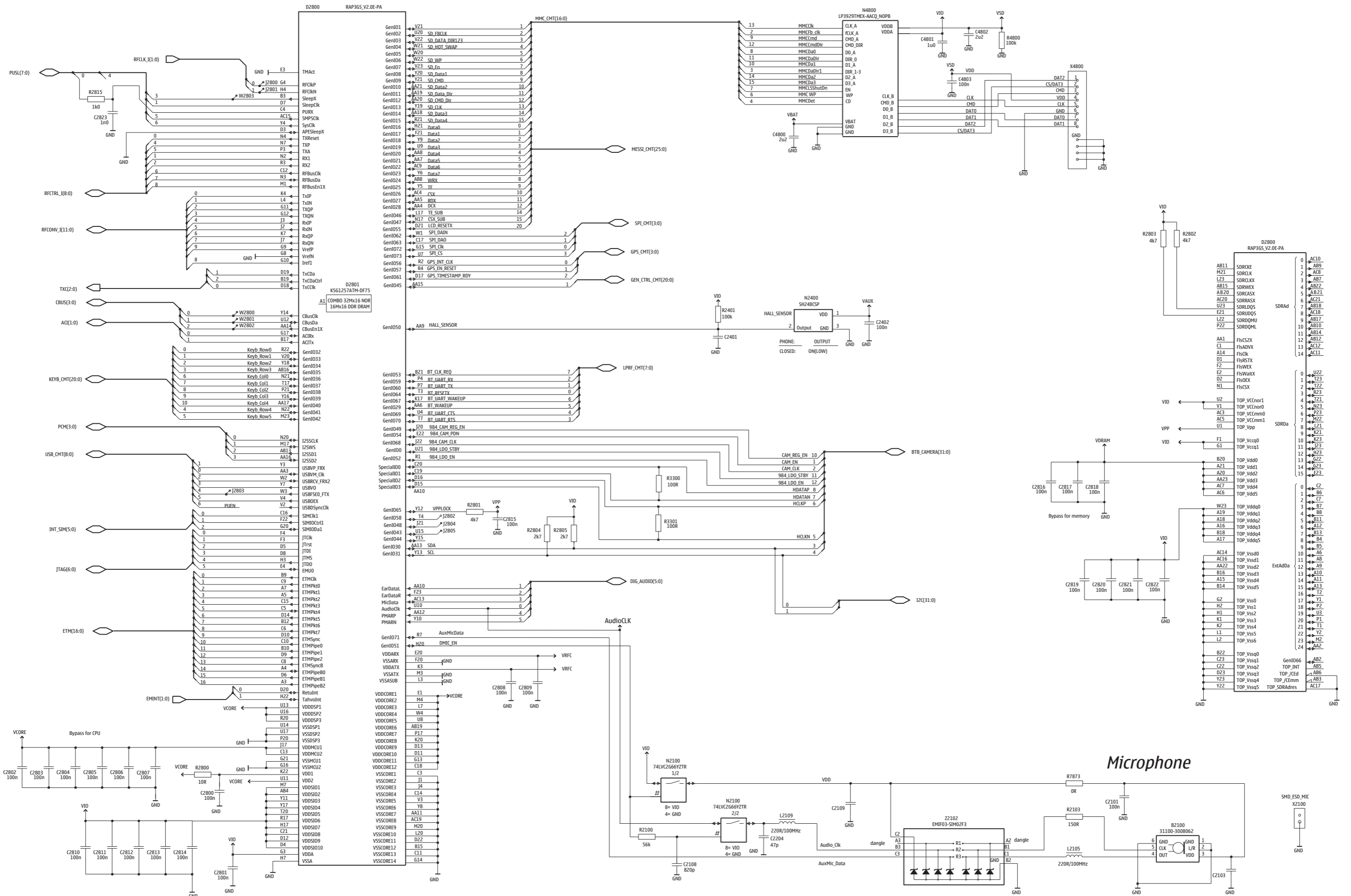


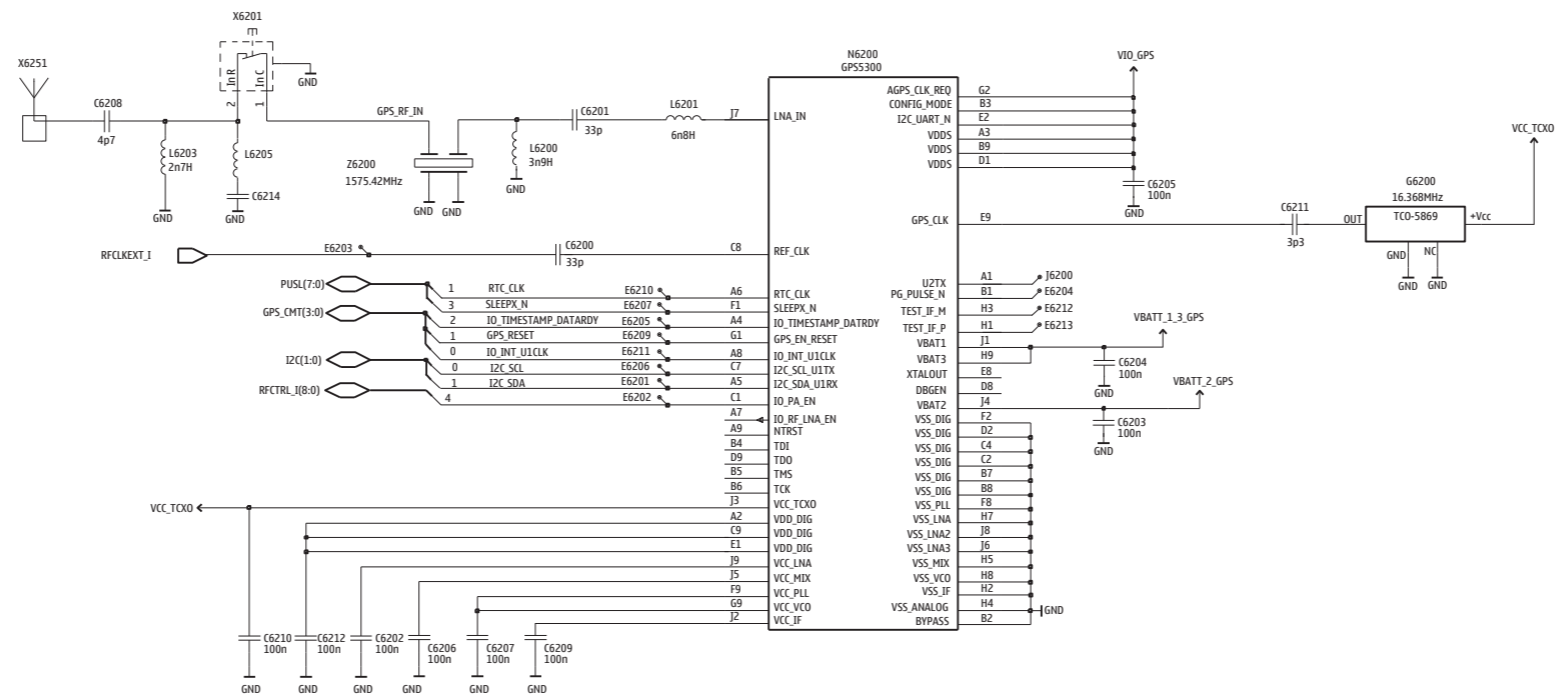
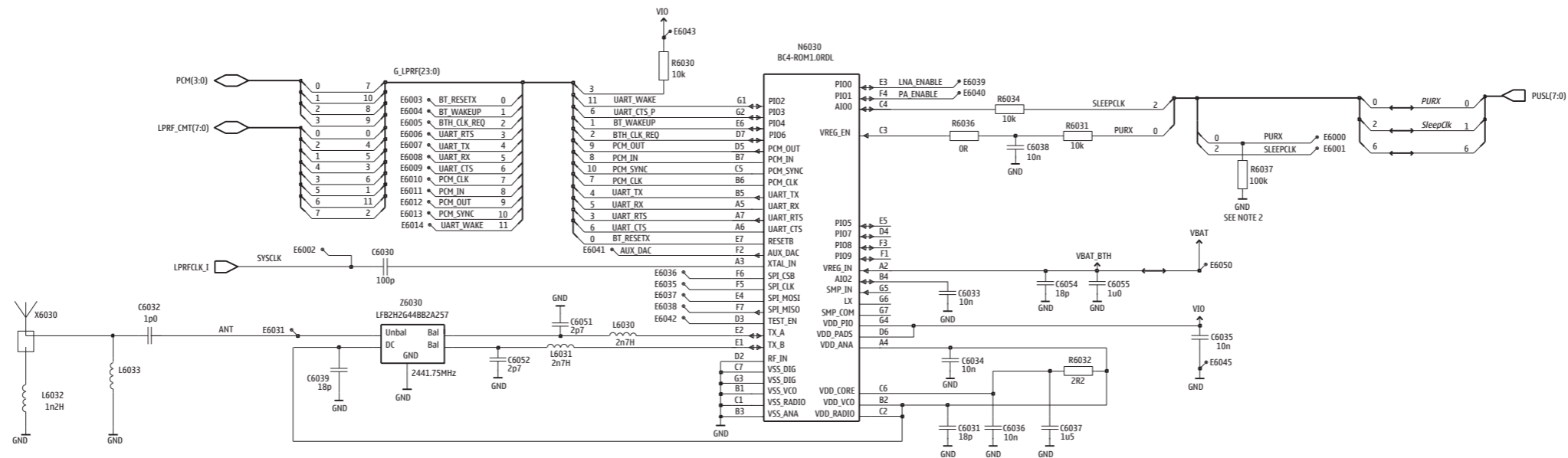
Table of contents	
Frontpage	1
BETTY, micro USB, LED drivers	2
AVILMA, SIM, Audio	3
RAP3GS, Combo, microSD, microphone	4
Bluetooth & GPS	5
User interface	6
RF part	7
Upper part (2ac_07g)	8
Component finder	9

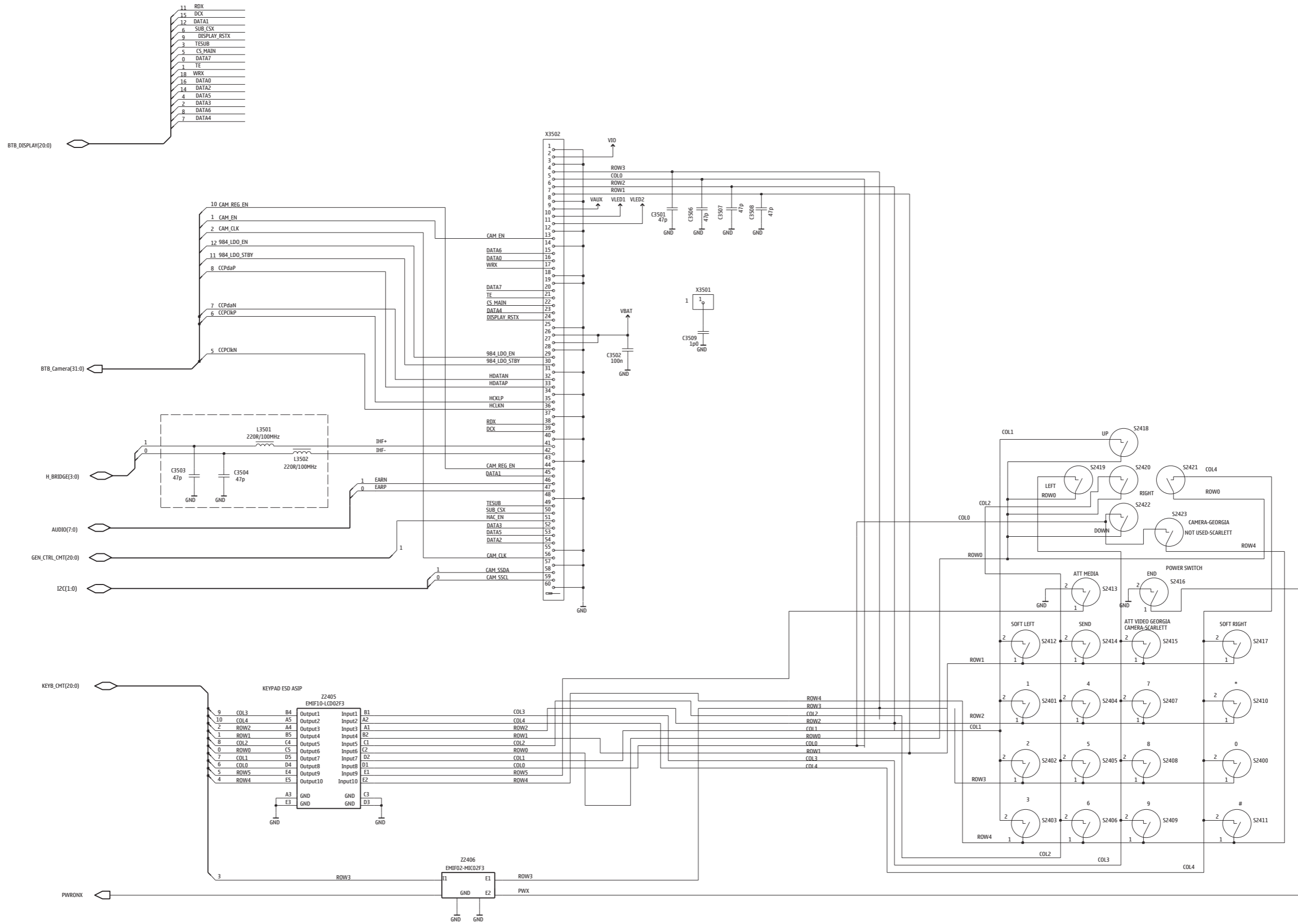
Copyright © NOKIA
This material, including documentation and any related computer programs is protected by copyright, controlled by NOKIA. All rights are reserved. Copying, including reproducing, modifying, storing, adapting or translating any or all of this material requires the prior written consent of NOKIA. This material also contains confidential information, which may not be disclosed to others without the prior written consent of NOKIA.

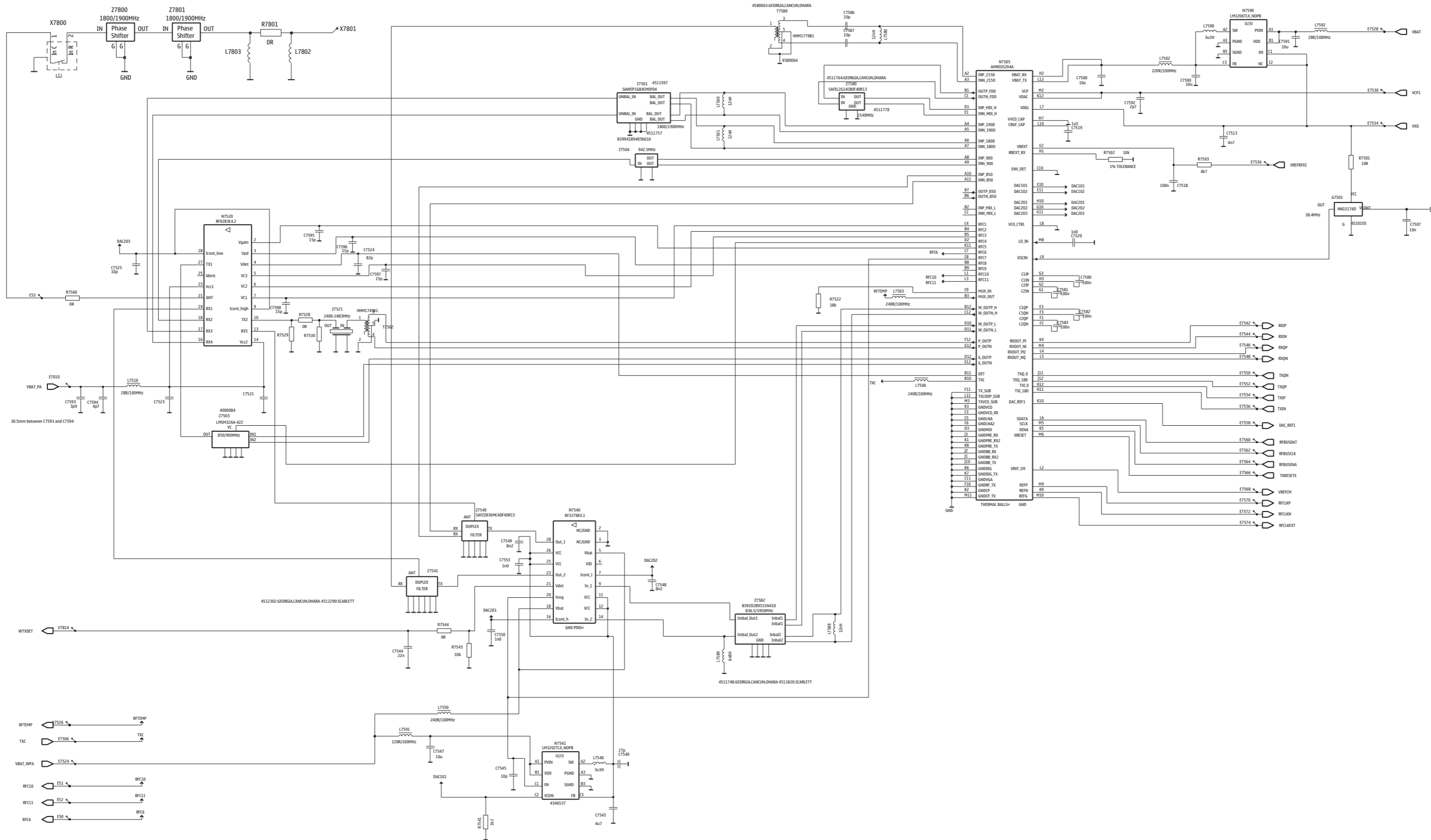




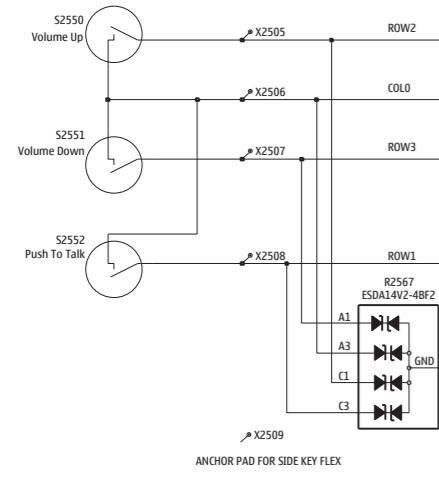




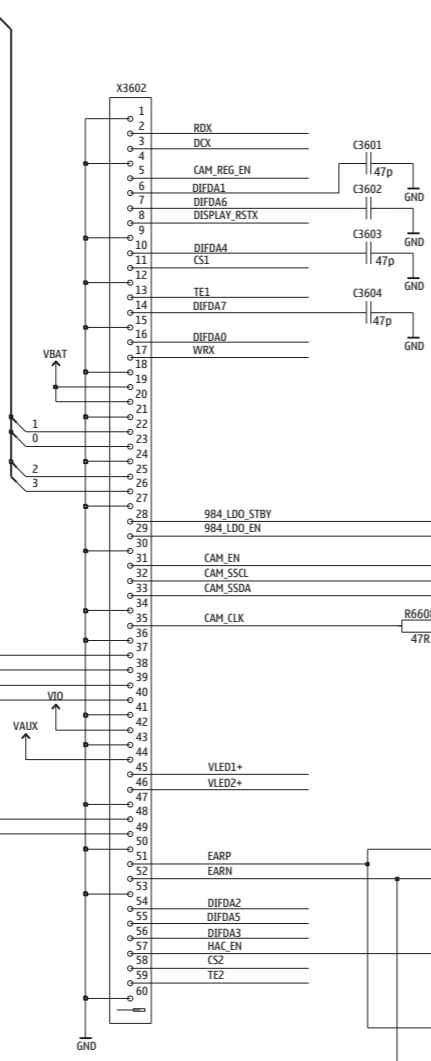




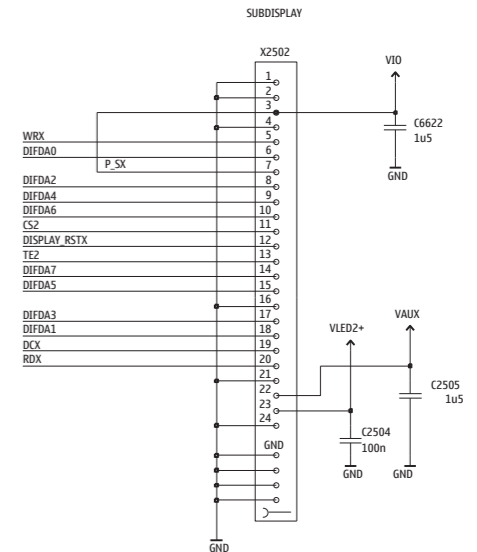
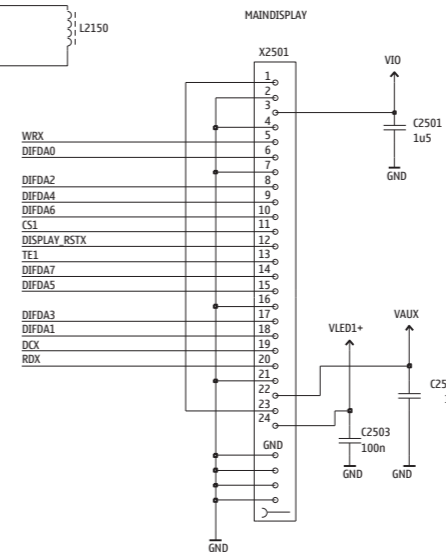
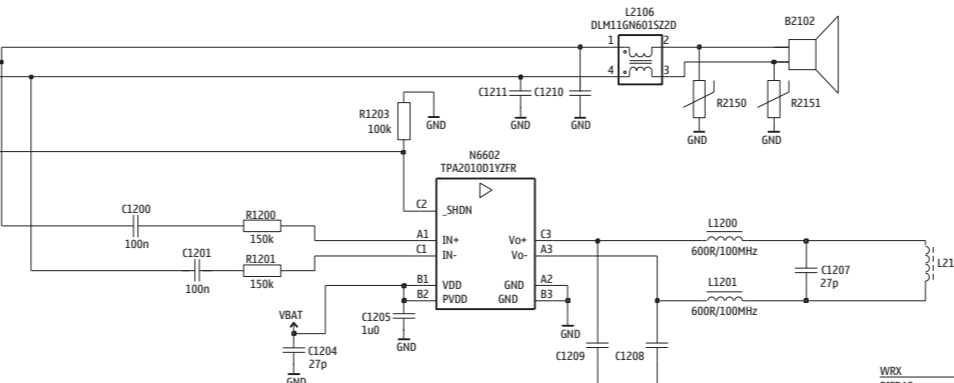
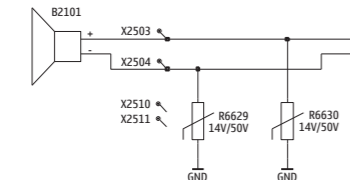
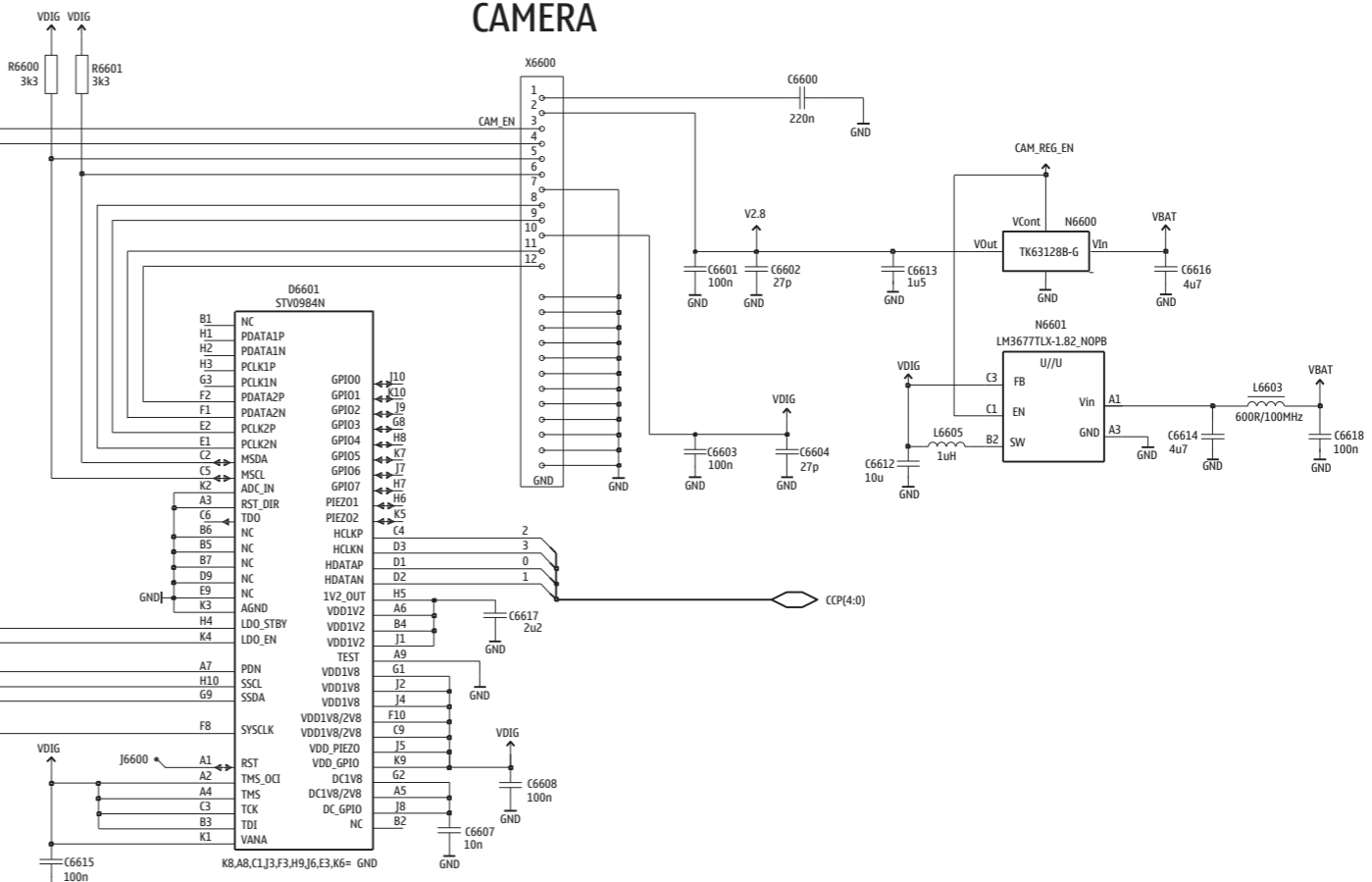
FLEX for KEYDOMES



B2B connector



CAMERA



B	C3504	L9	L2109	D4	R2555	N7	
B2100	D6	C3506	P8	L2202	L9	R2556	N7
B2200	J8	C3507	O8	L2205	L9	R2563	N6
C	C3508	O8	L2301	M7	R2800	J8	
C2000	F8	C3509	Q3	L2302	M7	R2801	L6
C2002	P8	C4800	M5	L2400	L9	R2802	L8
C2003	F8	C4801	M5	L2401	L8	R2803	I8
C2004	M9	C4802	M4	L2550	O8	R2804	L6
C2005	M8	C4803	L4	L2551	N8	R2805	L7
C2006	Q7	C6030	L3	L3501	L9	R2815	I6
C2007	Q7	C6031	L3	L3502	M9	R3300	I7
C2012	F8	C6032	M2	L6030	M3	R3301	I7
C2013	P9	C6033	L2	L6031	M3	R4800	M4
C2014	Q8	C6034	L3	L6032	Q3	R6030	N4
C2070	E3	C6035	N3	L6200	E6	R6031	N3
C2101	D5	C6036	L4	L6201	D6	R6032	L3
C2108	I9	C6037	L3	L6203	D6	R6034	M4
C2200	D4	C6038	N3	L7500	G4	R6036	N2
C2201	K8	C6039	M2	L7501	G4	R6037	N3
C2202	L9	C6051	M3	L7502	H4	R7501	G2
C2203	J9	C6052	M3	L7503	F3	R7502	F3
C2204	J9	C6054	M3	L7506	H3	R7503	F4
C2205	J9	C6055	M2	L7510	H7	R7509	H3
C2211	L8	C6200	F6	L7540	G8	R7522	H4
C2213	J8	C6201	D6	L7550	G9	R7528	H6
C2215	J8	C6202	E6	L7580	G4	R7541	G9
C2216	J8	C6203	D7	L7588	H4	R7543	G8
C2217	J9	C6204	E6	L7589	H4	R7544	G8
C2220	K8	C6205	E6	L7590	H5	R7560	G7
C2222	K8	C6206	D6	L7591	G9	R7801	D7
C2225	I8	C6207	E6	L7592	H5	R7873	D4
C2226	L8	C6208	C6	L7804	P8	T	
C2227	K8	C6209	D7	L7805	D2	T7502	H5
C2228	K8	C6210	D7	M	T7580	F5	
C2231	K9	C6211	E6	M2400	R4	V	
C2232	L8	C6212	D7	N	V2400	P6	
C2233	J9	C7500	H2	N2100	I9	V2401	I7
C2300	M7	C7507	H3	N2200	K8	V2402	P5
C2301	M7	C7513	G2	N2300	M6	V2403	F7
C2302	L7	C7518	F4	N2400	D5	V2404	F5
C2303	M5	C7519	G2	N2550	O8	V2405	I4
C2304	L6	C7520	G2	N4800	M5	V2407	N6
C2307	M7	C7524	F6	N6030	M3	V2409	O5
C2309	M8	C7525	F5	N6200	E7	V2410	O5
C2312	M5	C7540	G8	N7505	G3	V2550	P8
C2402	D4	C7543	G8	N7520	G6	V2553	P5
C2550	O7	C7544	G8	N7540	H8	V2560	N6
C2552	N8	C7545	G9	N7541	F8	V3502	P5
C2553	Q7	C7547	G9	N7590	H4	X	
C2554	P7	C7548	G9	R	X2000	F4	
C2556	N8	C7549	H8	R2002	P9	X2001	E2
C2557	P7	C7550	G9	R2003	P8	X2004	R9
C2700	P2	C7553	H8	R2004	D3	X2061	D8
C2701	P2	C7580	G2	R2007	F2	X2100	D6
C2800	J8	C7581	F2	R2009	F2	X2700	O4
C2801	L5	C7582	G2	R2010	F7	X3502	O9
C2802	I5	C7583	F3	R2011	P9	X4800	J3
C2803	I7	C7586	G4	R2012	Q7	X6030	Q2
C2804	I6	C7587	G4	R2013	Q7	X6201	D5
C2805	L7	C7590	H4	R2014	Q7	X6251	C5
C2806	K8	C7591	H4	R2015	Q7	X7800	E8
C2807	L6	C7592	F2	R2017	Q8	Z	
C2808	I6	C7593	F3	R2018	Q9	Z2102	D4
C2809	I7	C7594	H6	R2060	Q6	Z2403	M8
C2810	I8	C7595	F6	R2070	E4	Z2404	M9
C2811	I5	C7596	G5	R2071	N8	Z2405	L8
C2812	L5	C7597	G5	R2100	I9	Z2406	M8
C2813	L7	C7598	F6	R2103	D5	Z6030	M2
C2814	L6	D	R2200	L9	Z6200	E5	
C2815	L5	D2800	K6	R2300	E4	Z7501	G5
C2816	L6	D2801	K6	R2401	D3	Z7503	G5
C2817	L7	F	R2402	P6	Z7504	G4	
C2818	I7	F2000	F9	R2403	Q3	Z7521	H6
C2819	I7	G	R2404	Q3	Z7540	H7	
C2820	L7	G2200	D3	R2405	O5	Z7541	H7
C2821	L8	G6200	E5	R2410	N6	Z7580	F4
C2822	I5	G7501	H3	R2413	O5	Z7582	H3
C2823	I6	L	R2422	O6	Z7800	D8	
C3100	I6	L2001	Q9	R2423	O6	Z7801	D7
C3501	P8	L2002	Q7	R2552	P5		
C3502	N8	L2003	Q9	R2553	P6		
C3503	L9	L2105	D4	R2554	P6		

