

RF Top Level v. 0.0 ed. 4

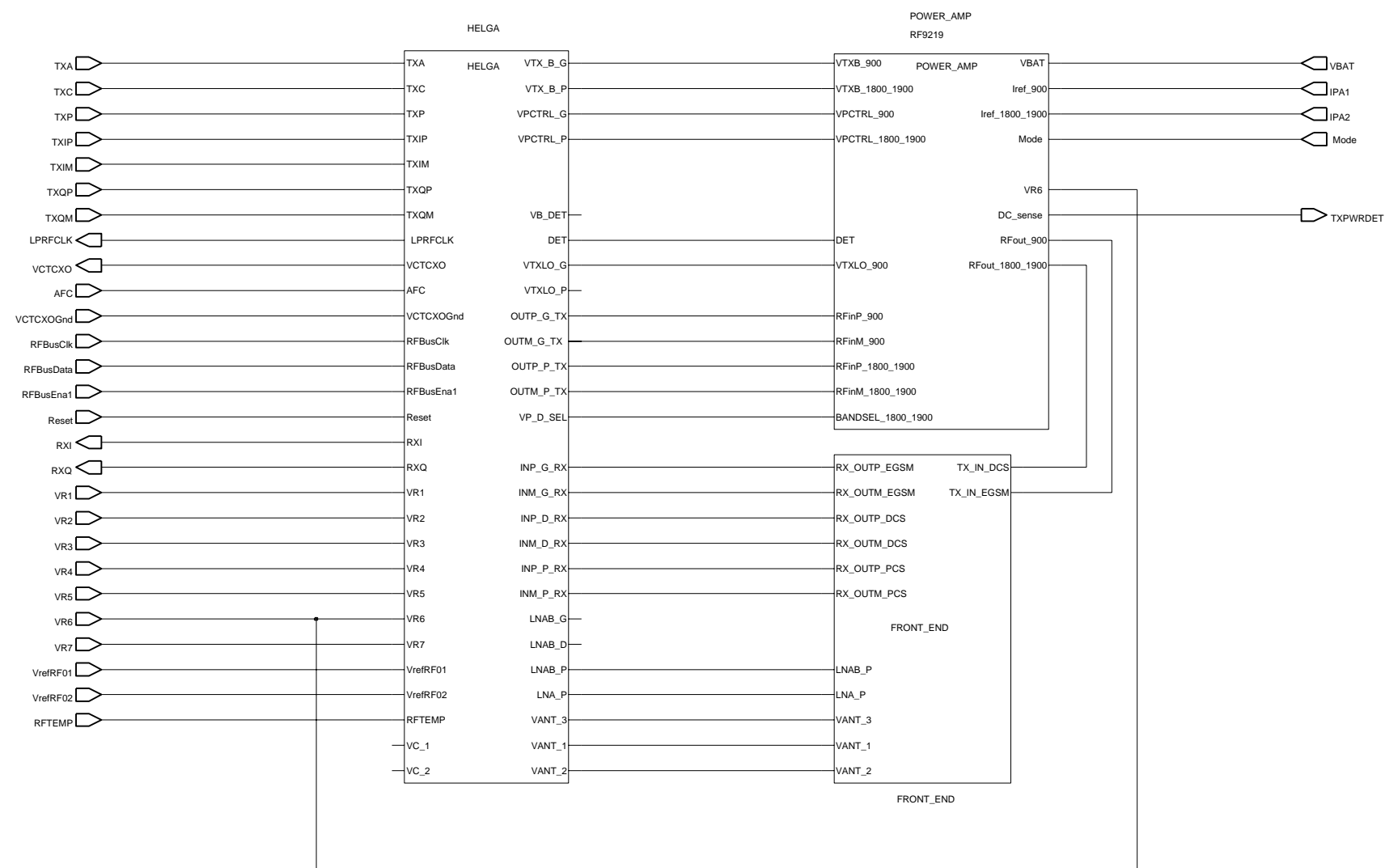

RF and BB Shields v. 0.0 ed. 11

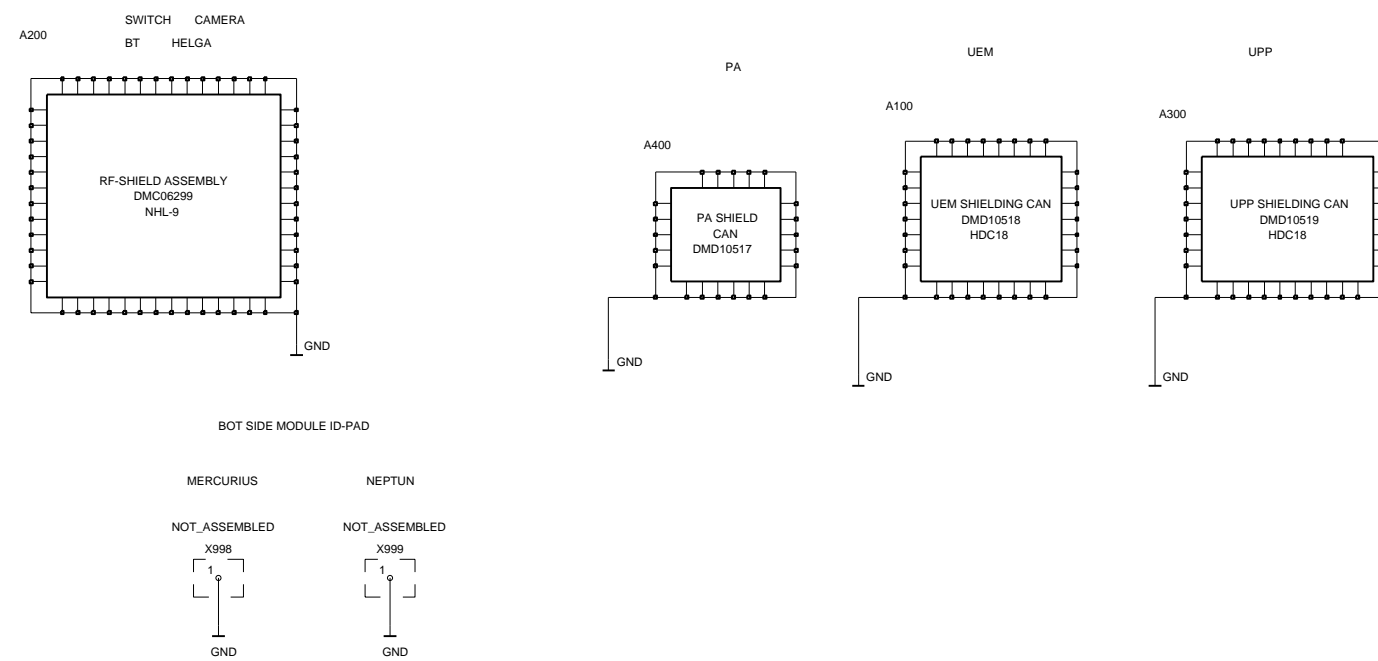

DCT4.0 Top Level v. 5.0 ed. 40

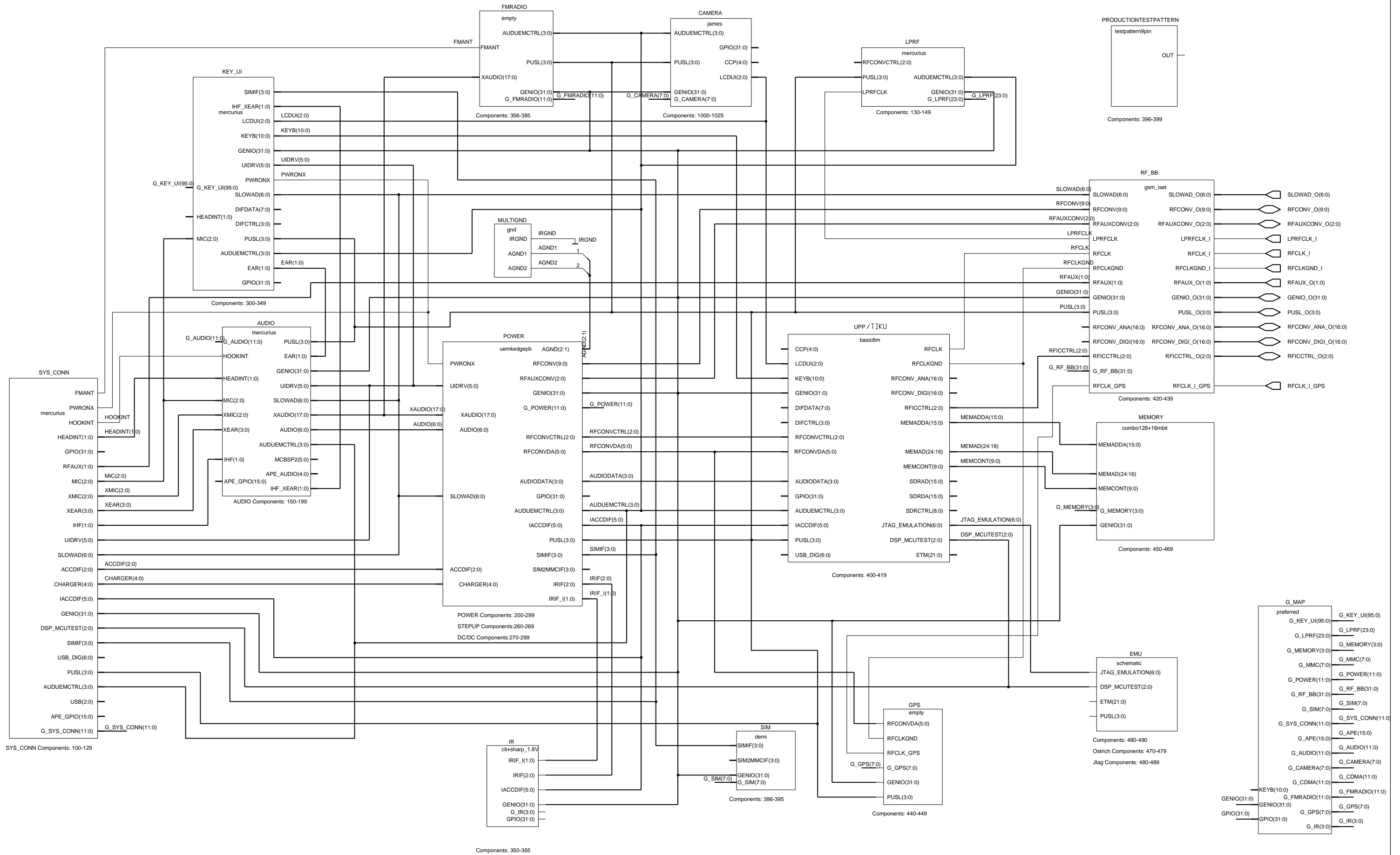

Test and Emulator Interface v. 2.0 ed. 43

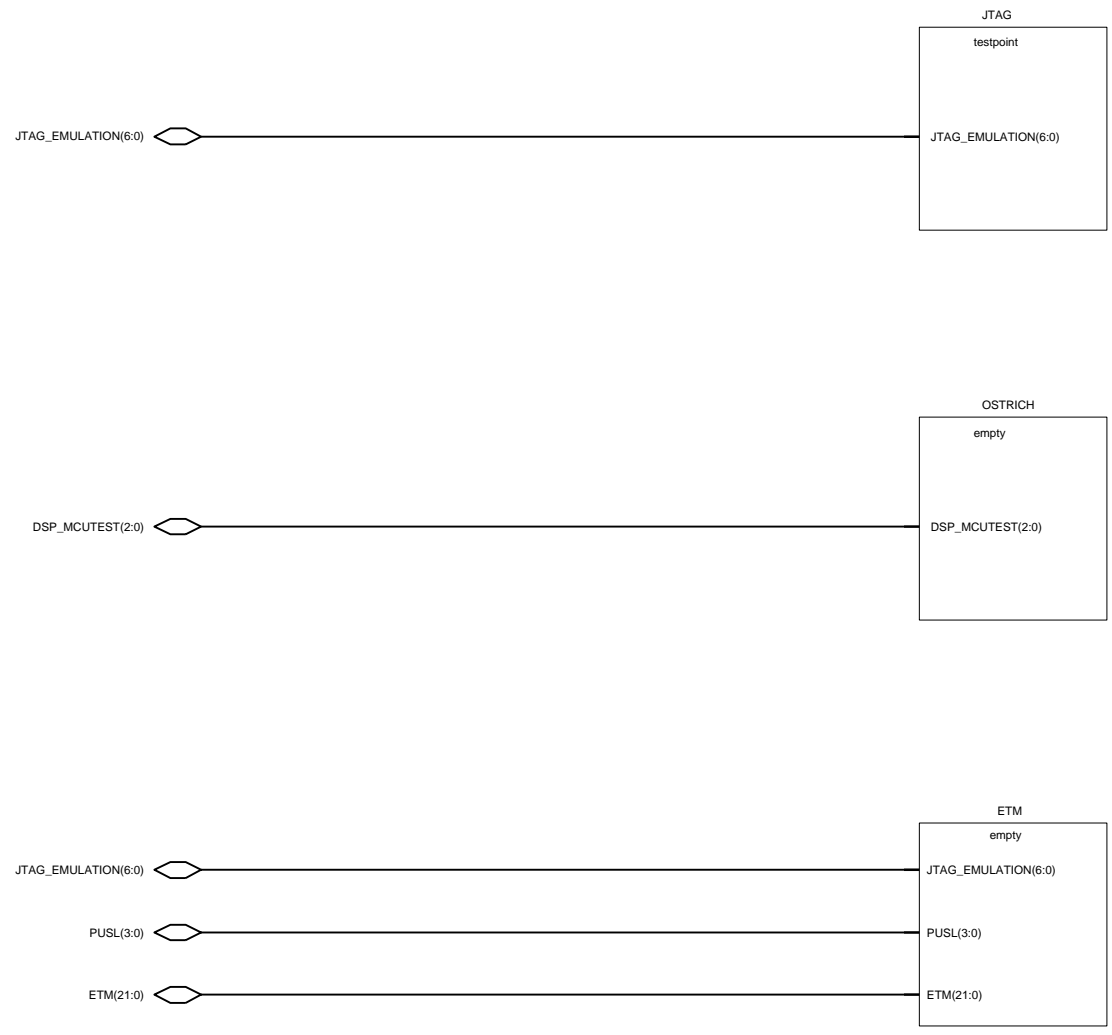

Test Points for JTAG Emulator v. 1.3 ed. 13

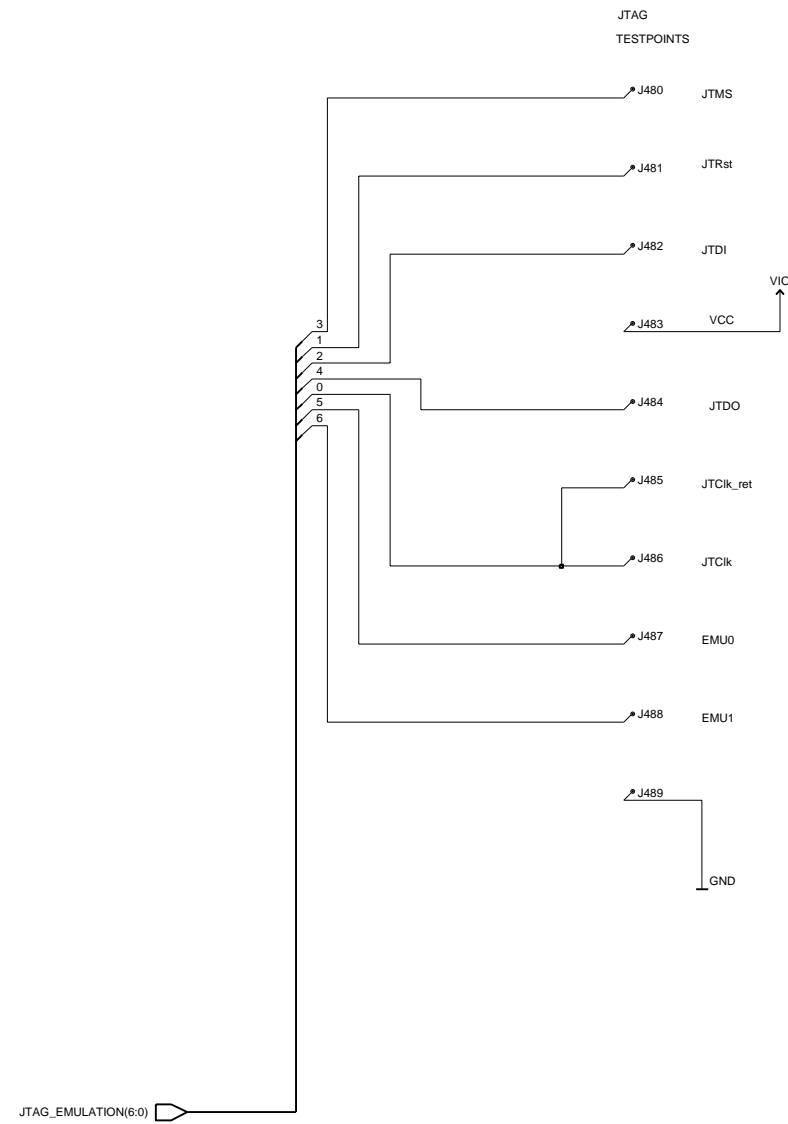

No Test Interface in This Product v. 1.3 ed. 8

DSP_MCU TEST(2.0) 

Module BlueCore2-ROM v. 0 ed. 80

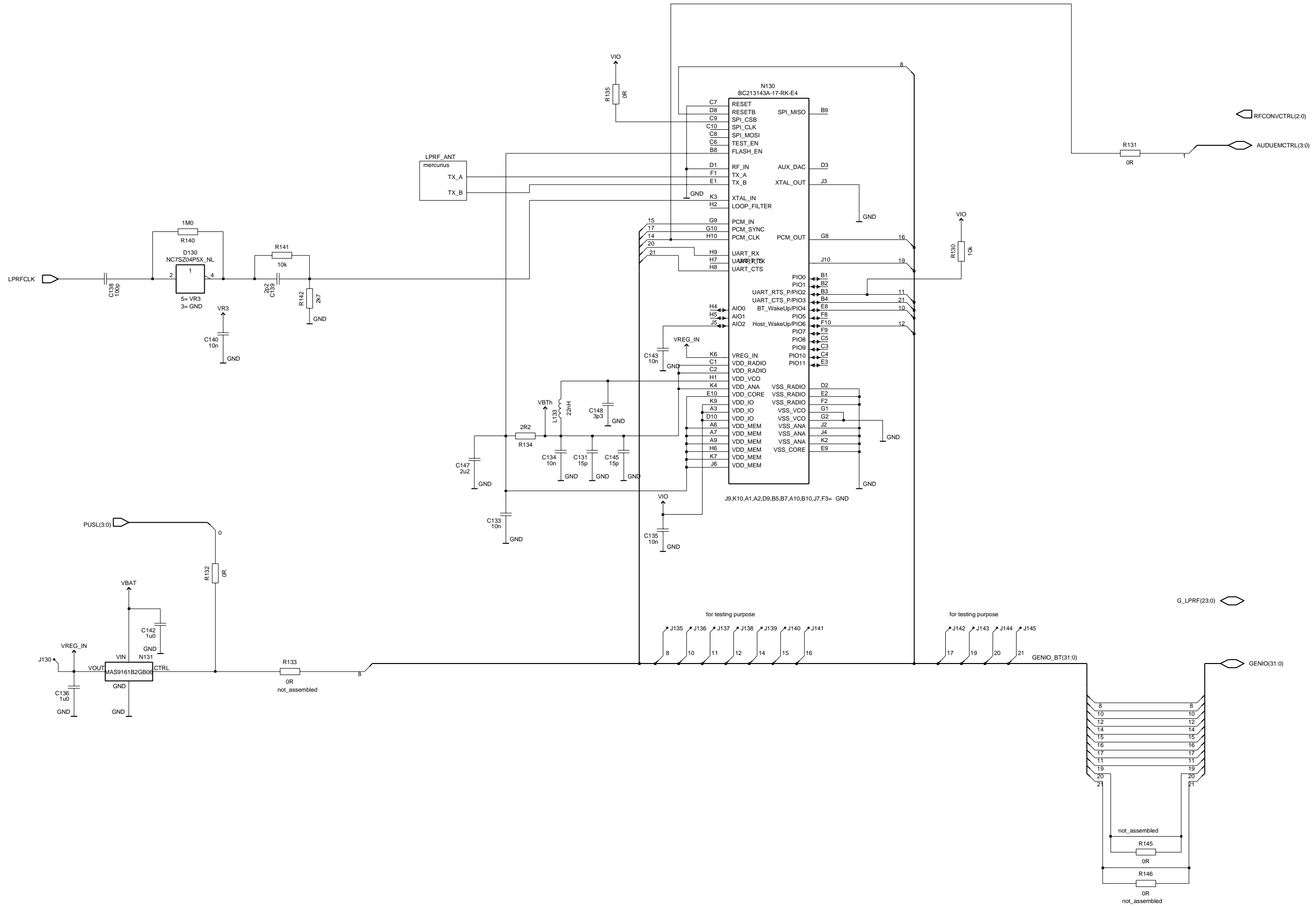

LPRF Antenna v. 0 ed. 22

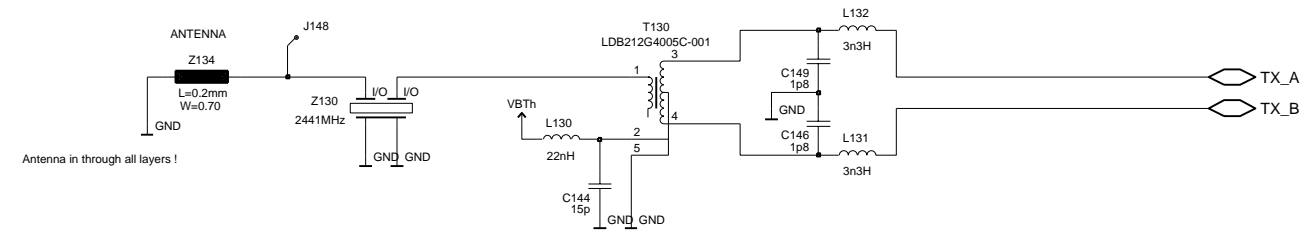

9 pin Production Test Pattern v. 1.3 ed. 14

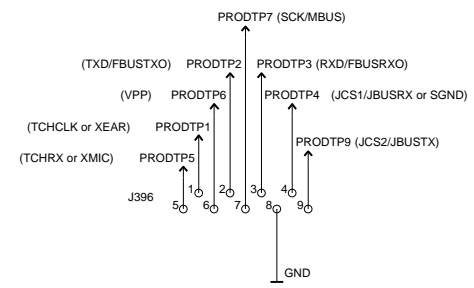

OUT

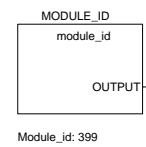

OUTPUT 

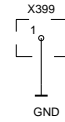

IR Module 1.8V v. 0.0 ed. 51

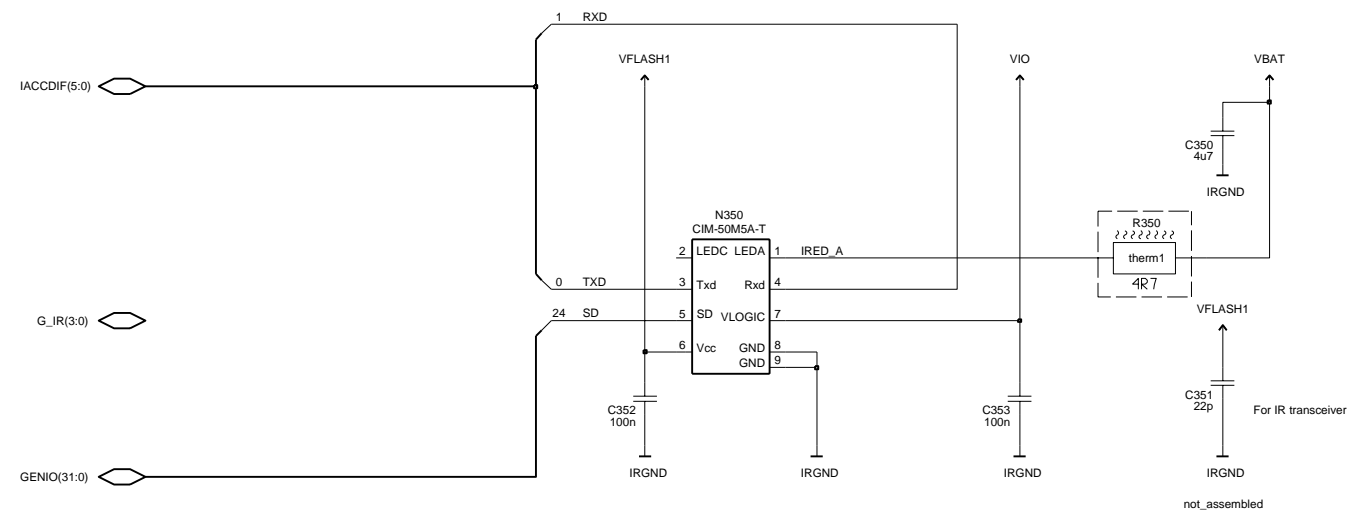

GPIO(31:0)

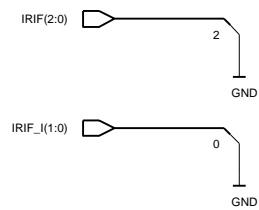

UEM IR level shifters
are ground, when 1.8V
IR is used!

Used referenses

- C 350 - 353
- N 350
- R 350

Camera v. 0 ed. 62

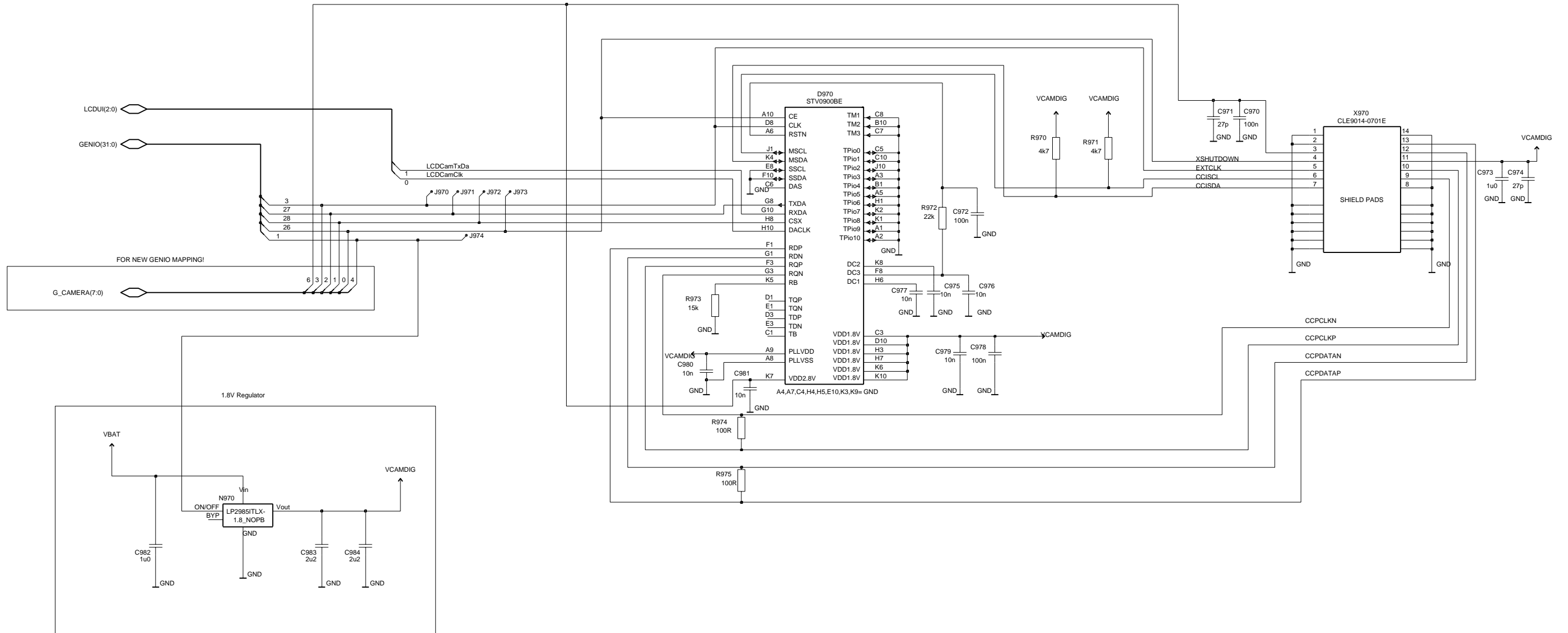
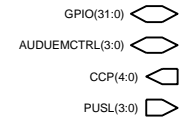

GENIO and GPIO Connection Block v. 0.0 ed. 9

That connections used only if TEA5767 or CIT+SHARP_1.8V schematics are selected

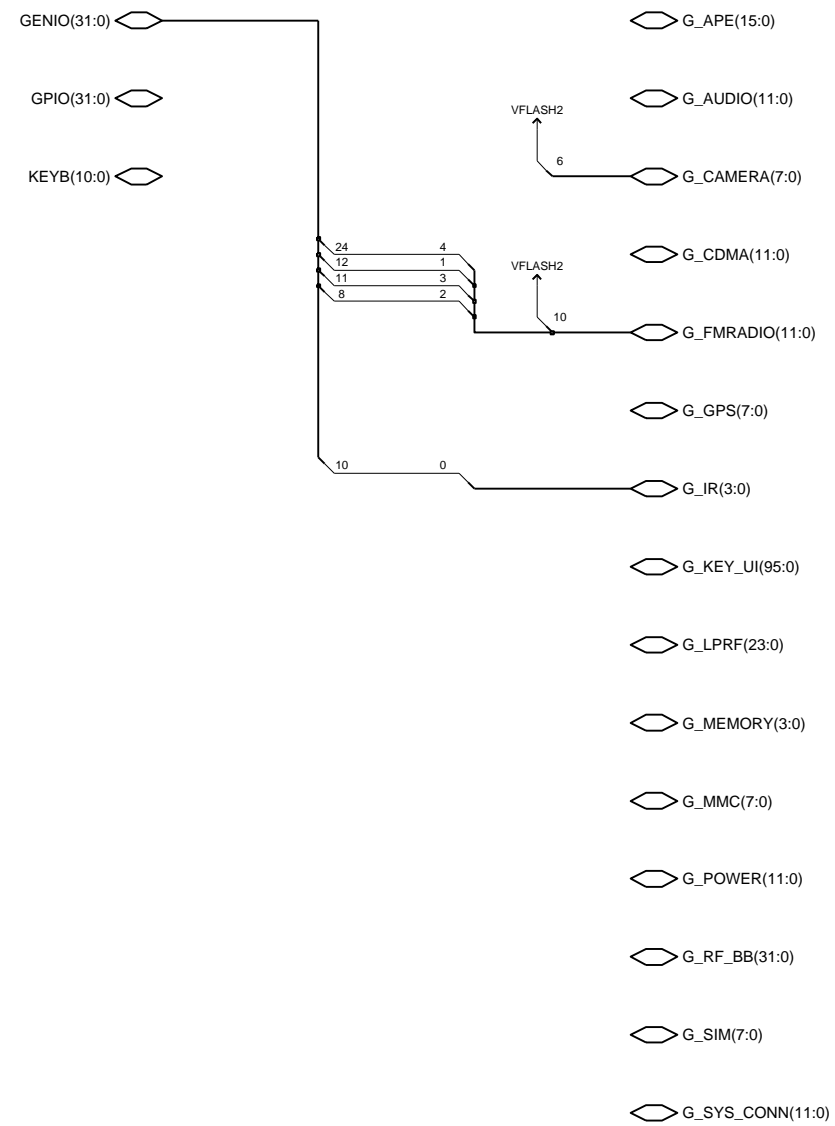

Combo Memory 128+16Mbit v. 2.0 ed. 78

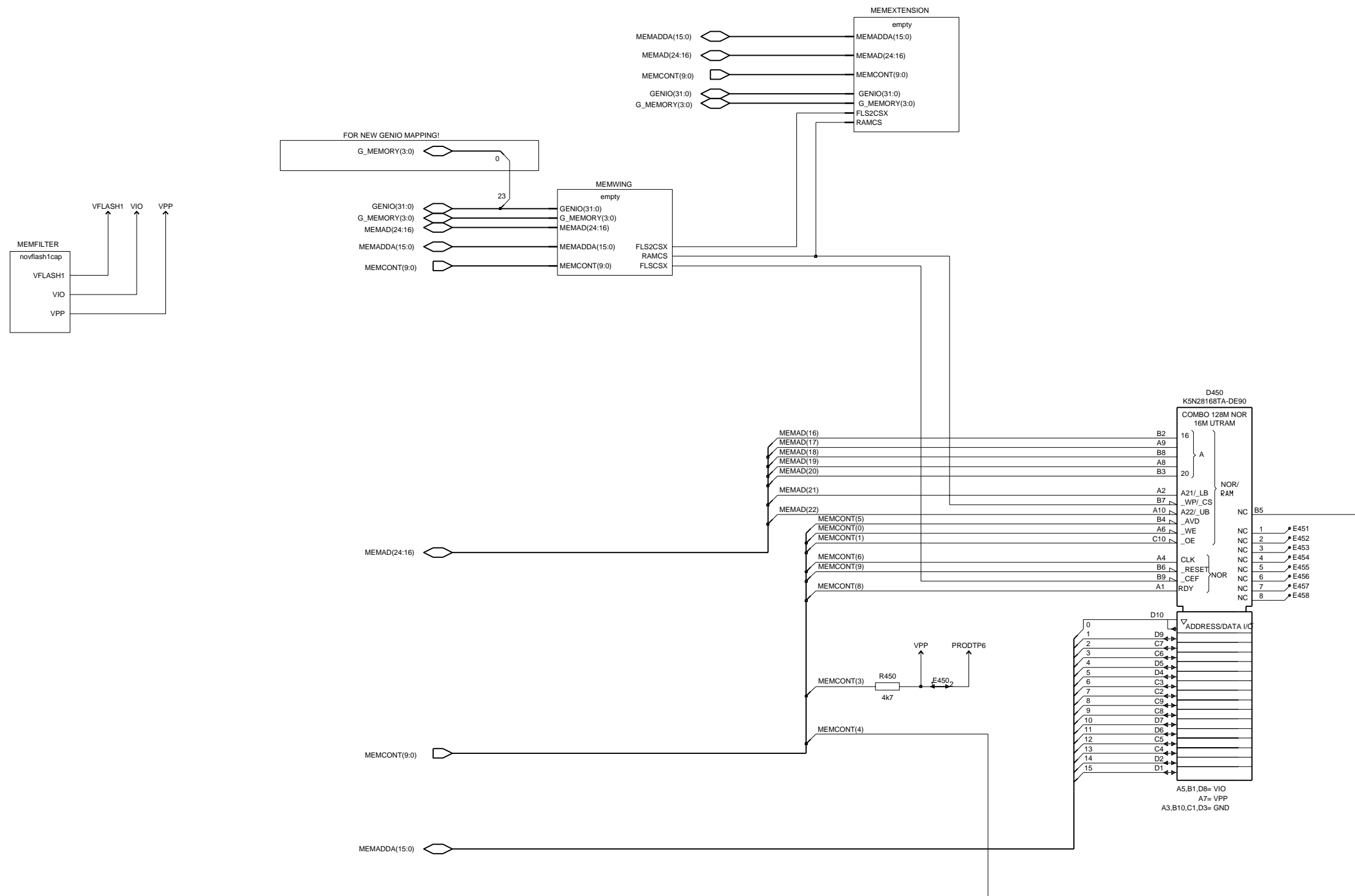

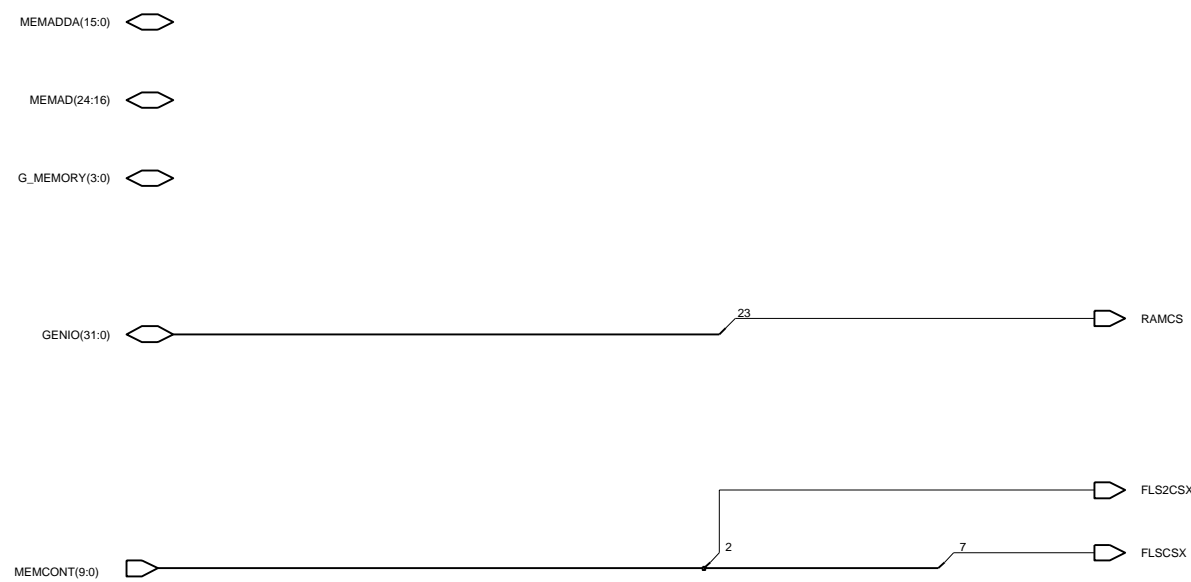

Discrete Capacitors for Memory without VFlash1 v. 1.3 ed. 2



SIM reader v. 1.3 ed. 58

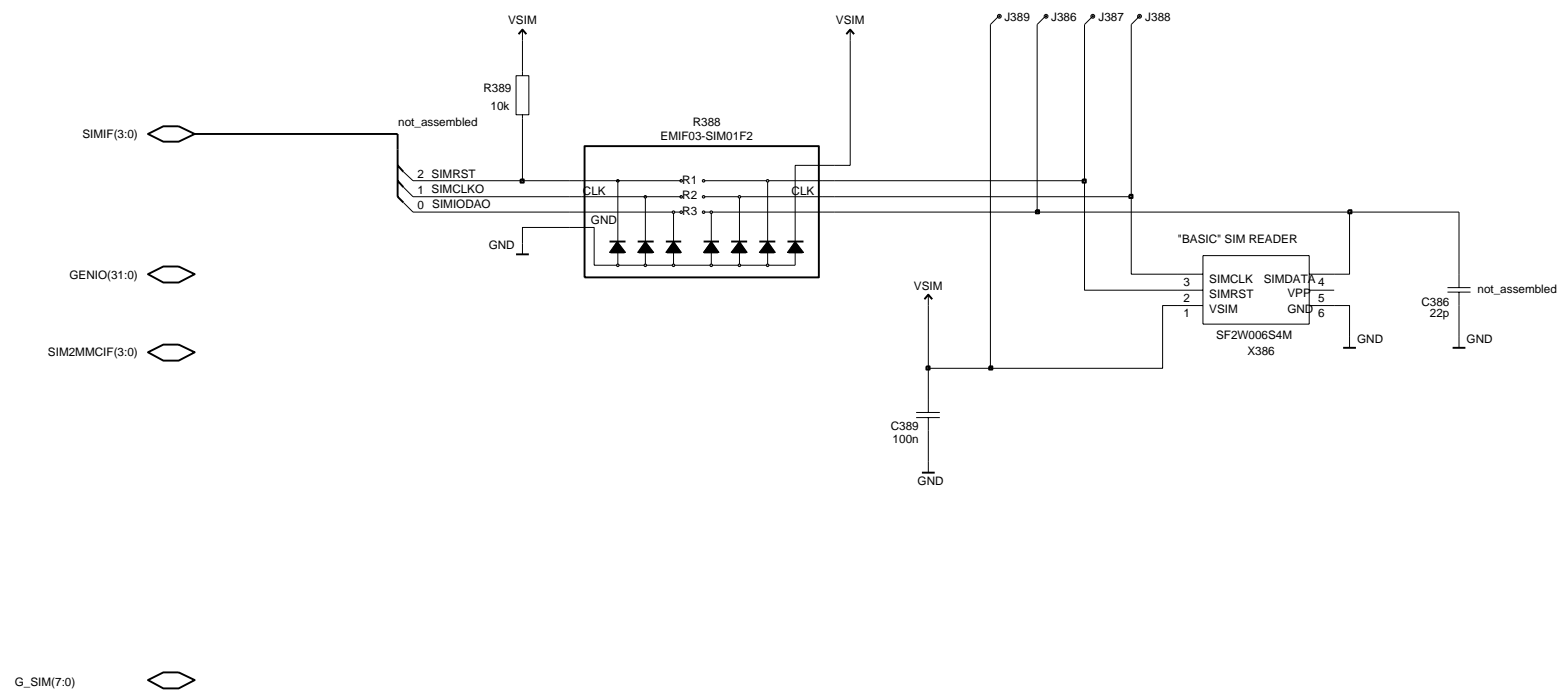

G_SIM(7:0)

Discrete Power Management v. 1.3 ed. 2

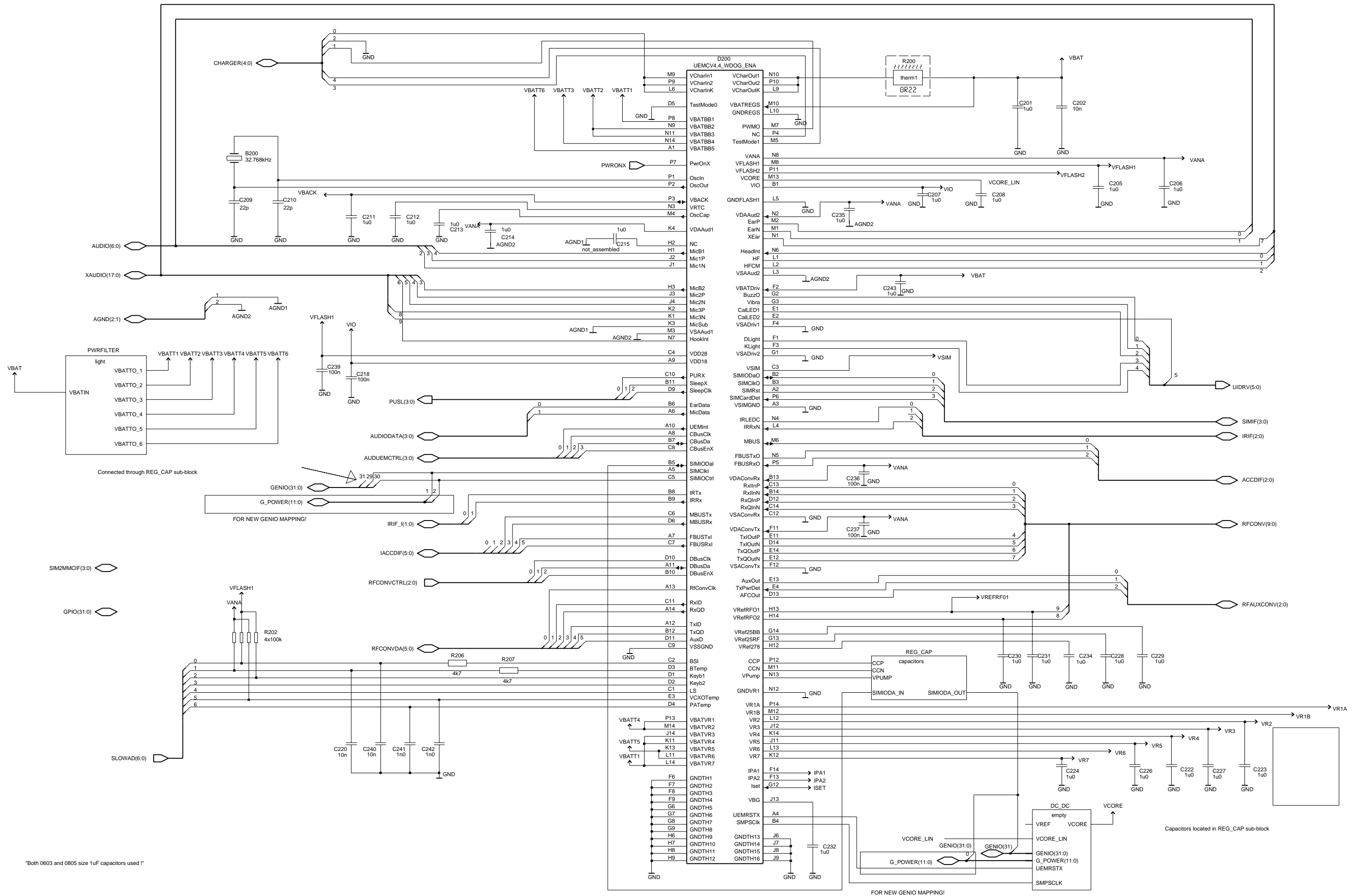

"Both 0603 and 0805 size 1uF capacitors used!"

Used refs in REG_CAP: C238, C200, C219, C233, C221 and R205

DC/DC Converter v. 0.0 ed. 11

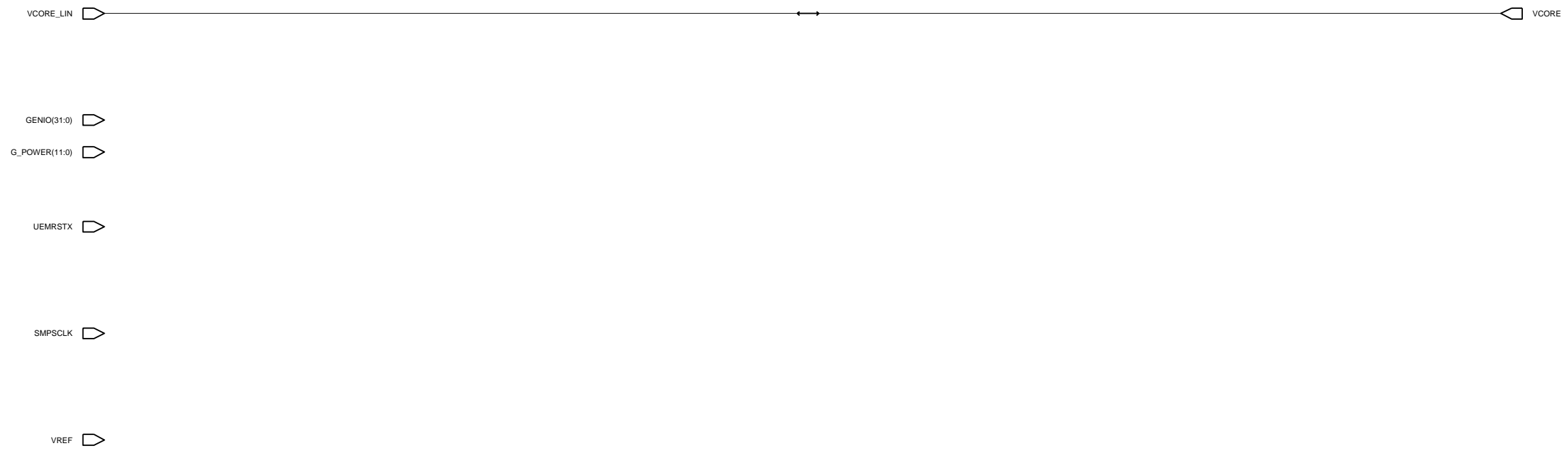

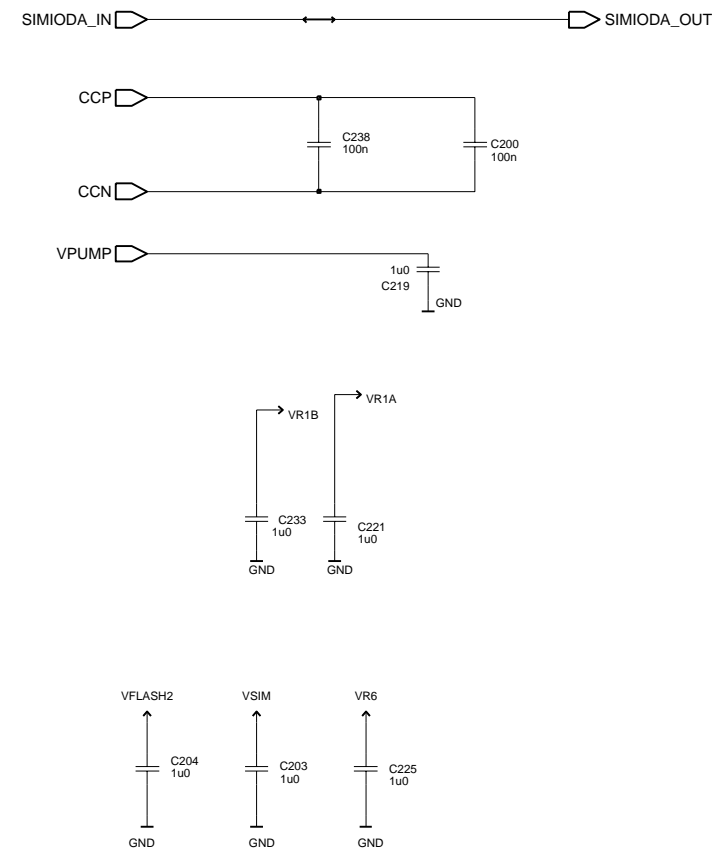

Light Filtering v. 2.0 ed. 29

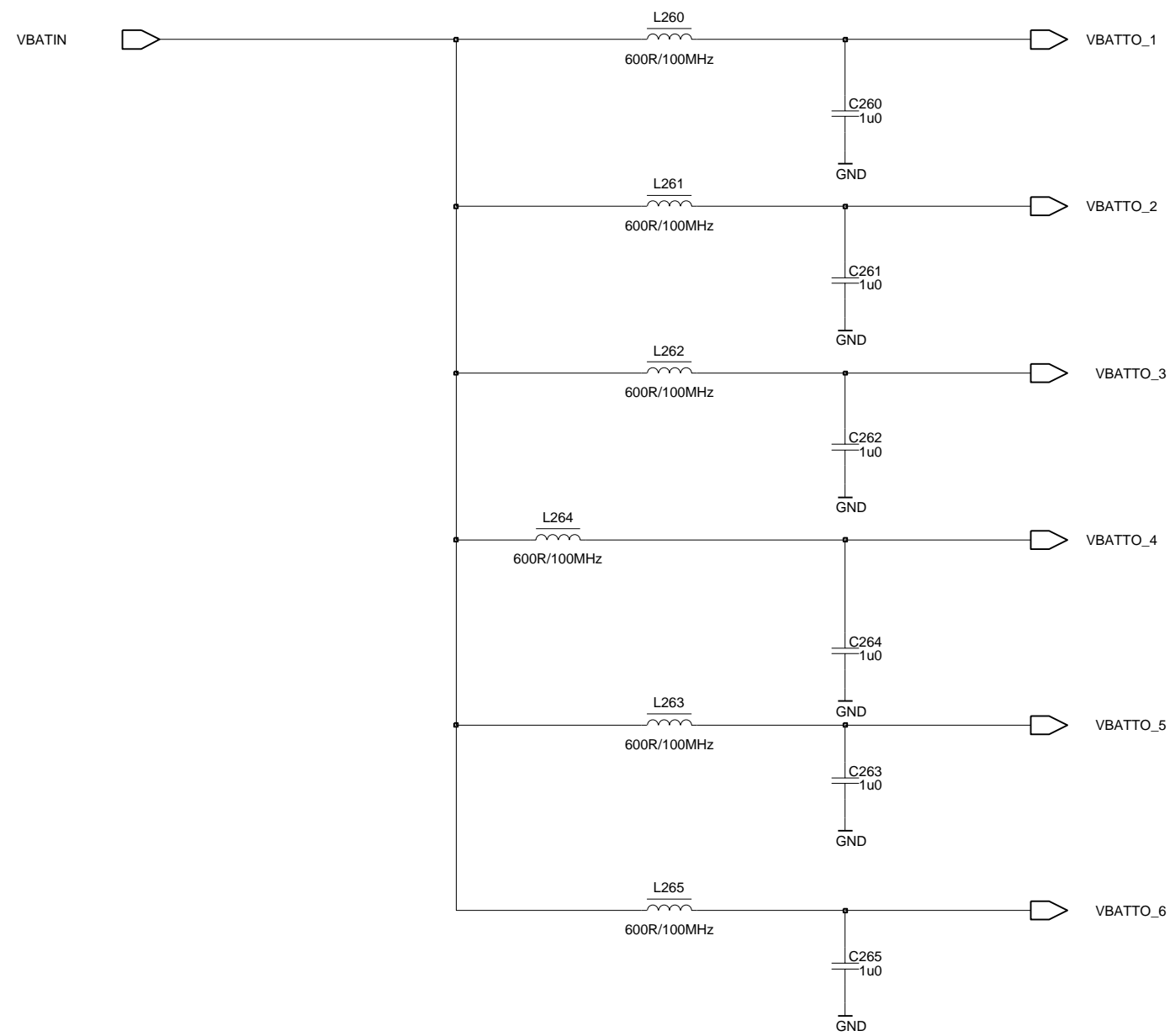

UPP 8M Implementation v. 2.0 ed. 107

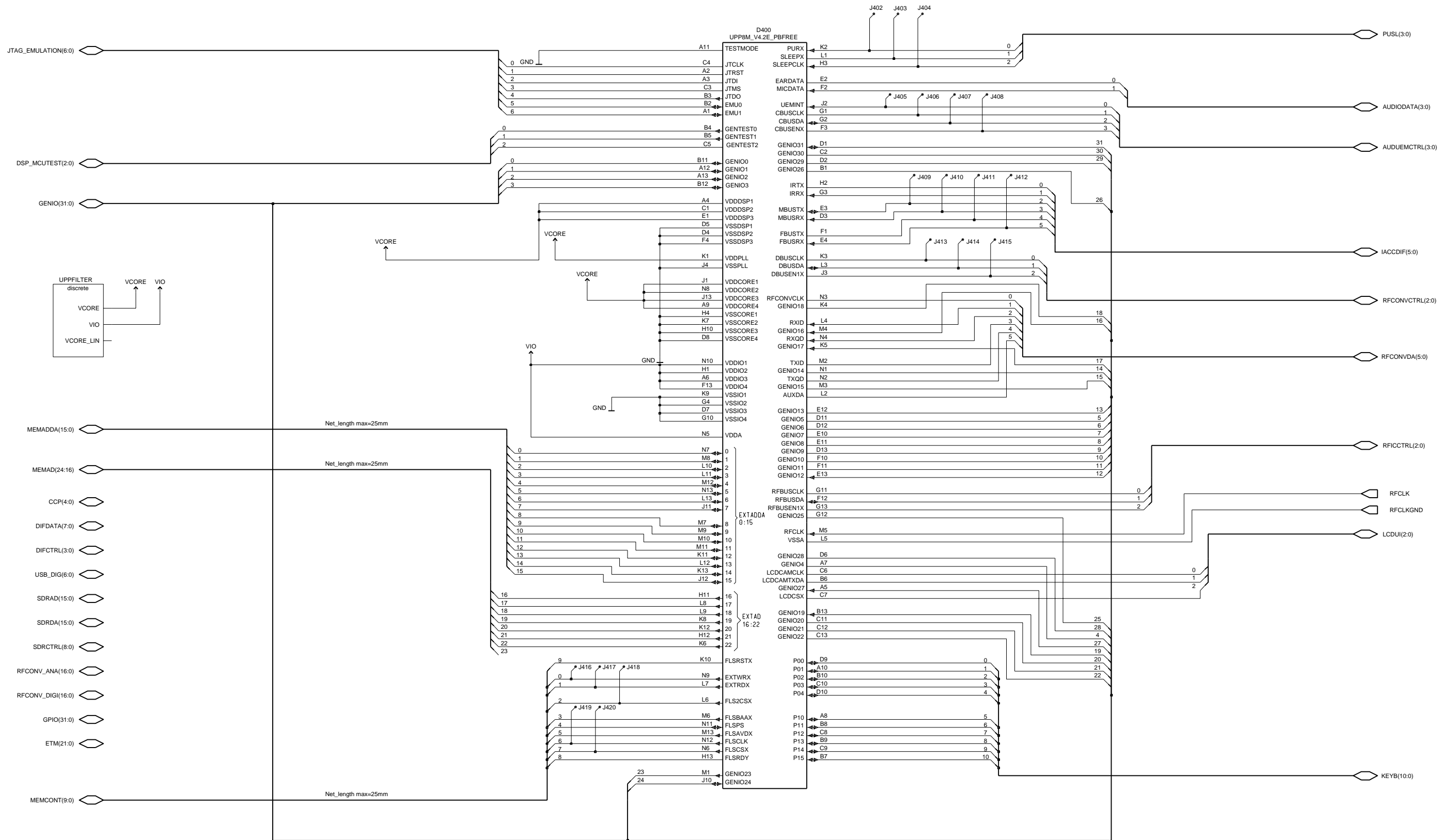

Discrete Decoupling Capacitors for UPP v. 1.3 ed. 11

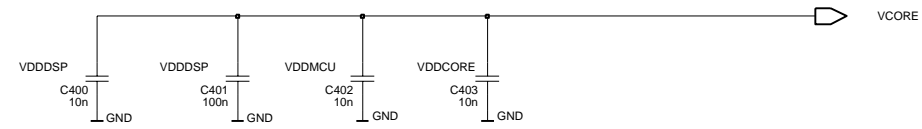

VCORE_LIN

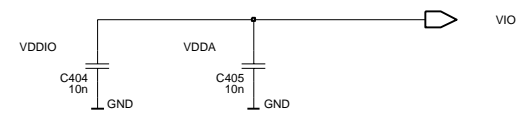

GSM RF - Baseband Interface v. 1.3 ed. 45

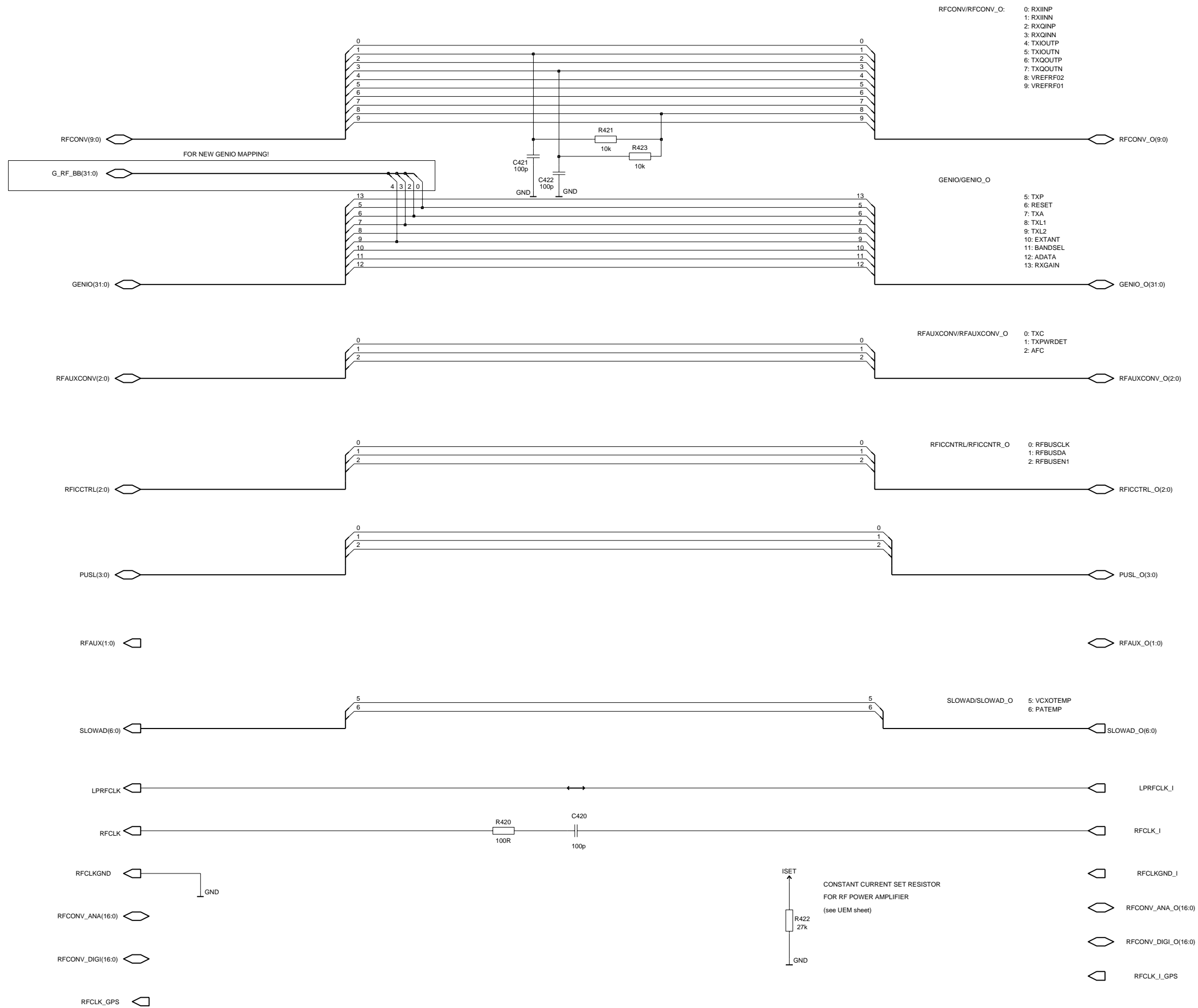

IPA1 AND IPA2 ARE USED IN RF, THE TOLERANCE OF R422 IS 1% (0402, 1430873)

System Connector v. 0.0 ed. 4

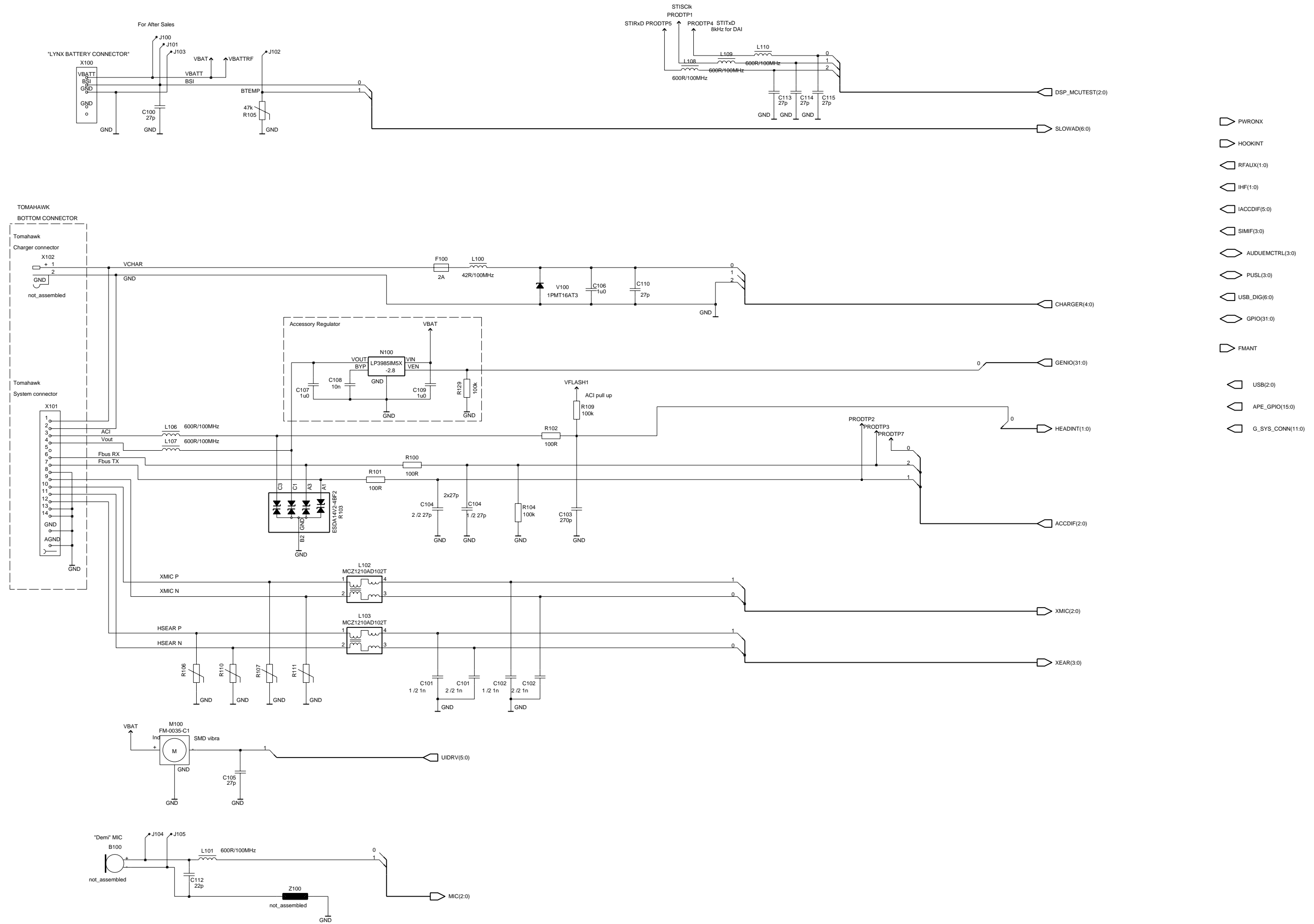

Audio v. 0.0 ed. 56

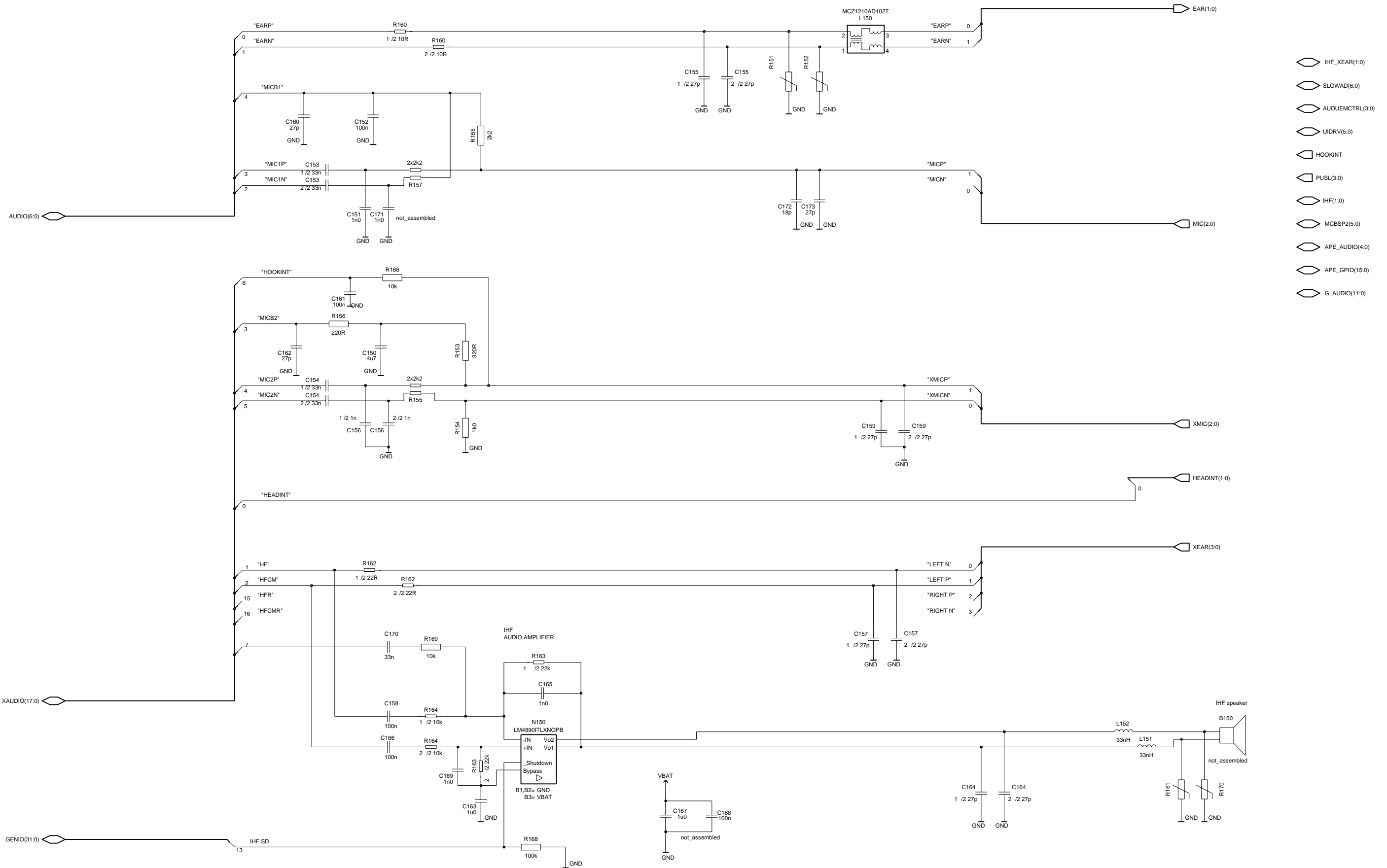

MultiGND Symbol Bypass v. 0.0 ed. 12

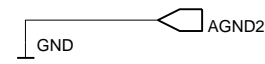
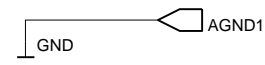
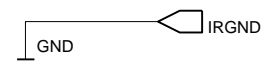

Parts Placement Diagram tb6_23ia top

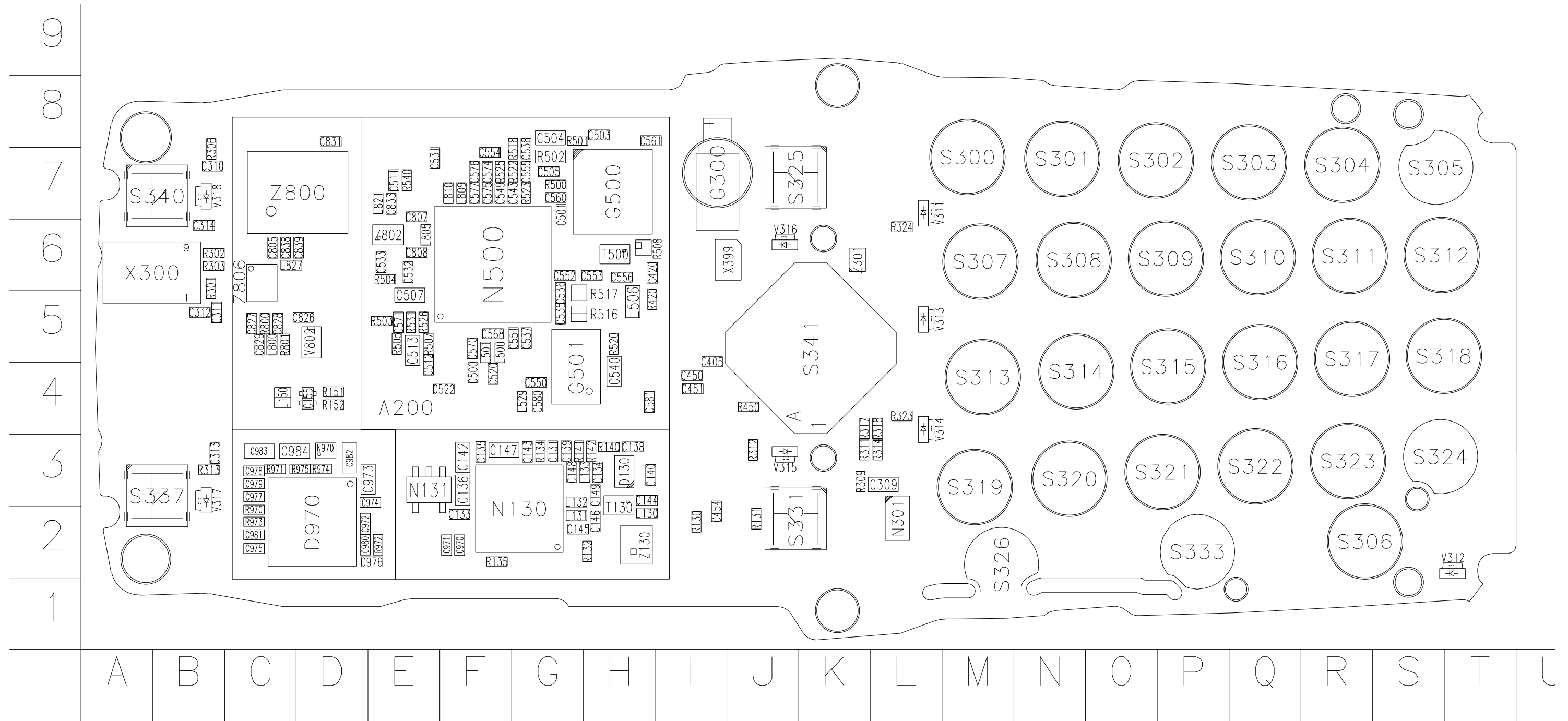

Parts Placement Diagram tb6_23ia Bottom

