

Service Schematics

NOKIA 7373

RM-209

Introduction

IMPORTANT:

This document is intended for use by authorized NOKIA service centers only.

“Service Schematics” was created with focus on customer care.
The purpose of this document is to provide further technical repair information for NOKIA mobile phones on Level 3/4 service activities.
It contains additional information such as e.g. “Component finder”.
The “Signal overview” page gives a good and fast overview about the most important signals and voltages on board.
Saving process time and improving the repair quality is the aim of this document.
It is to be used additionally to the service manual and other training or service information such as Service Bulletins.

All measurements were made using following equipment:

Nokia repair SW : Phoenix version 2006.12.5.136
Oscilloscope : Fluke PM 3380A/B
Spectrum Analyzer : Advantest R3162 with an analog probe
RF-Generator / GSM Tester : Rhode & Schwarz CMU 200
Multimeter : Fluke 73 Series II

While every endeavour has been made to ensure the accuracy of this document, some errors may exist. If the reader finds any errors, NOKIA shall be notified in writing.

Please send E-Mail to: training.sace@nokia.com

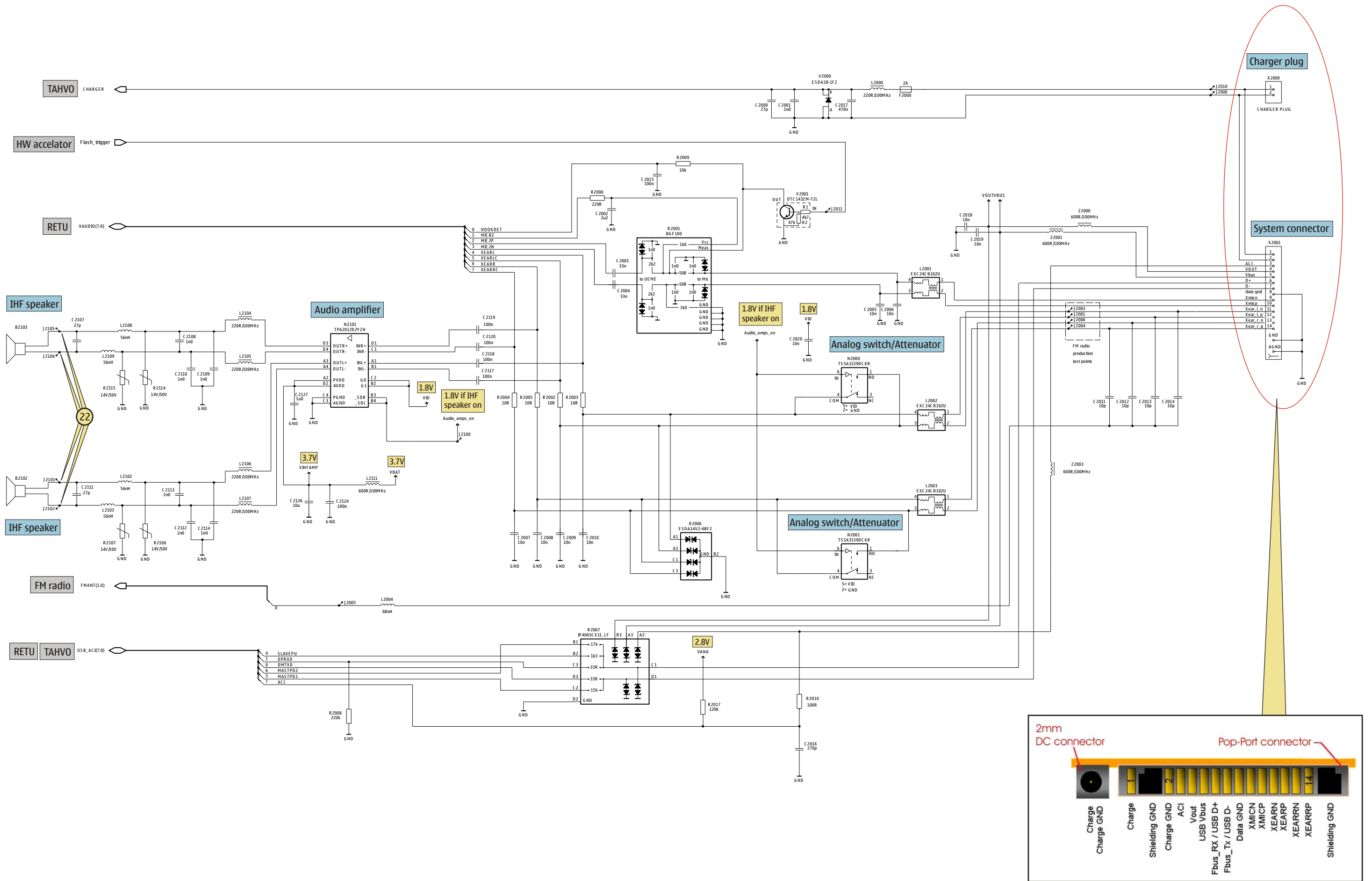

Table of Content

Front page	1
System connector, IHF speaker	2
RETU, SIM, Micro, Vibra	3
TAHVO	4
RAPGSM, Combo memory, Camera	5
UI, Key PWB, LCD PWB, Earpice	6
Bluetooth, FM radio, microSD	7
RF part	8
Signal overview	9
Component finder	10

Copyright © NOKIA

This material, including documentation and any related computer programs is protected by copyright, controlled by NOKIA. All rights are reserved. Copying, including reproducing, modifying, storing, adapting or translating any or all of this material requires the prior written consent of NOKIA. This material also contains companyconfidential information, which may not be disclosed to others without the prior written consent of NOKIA.



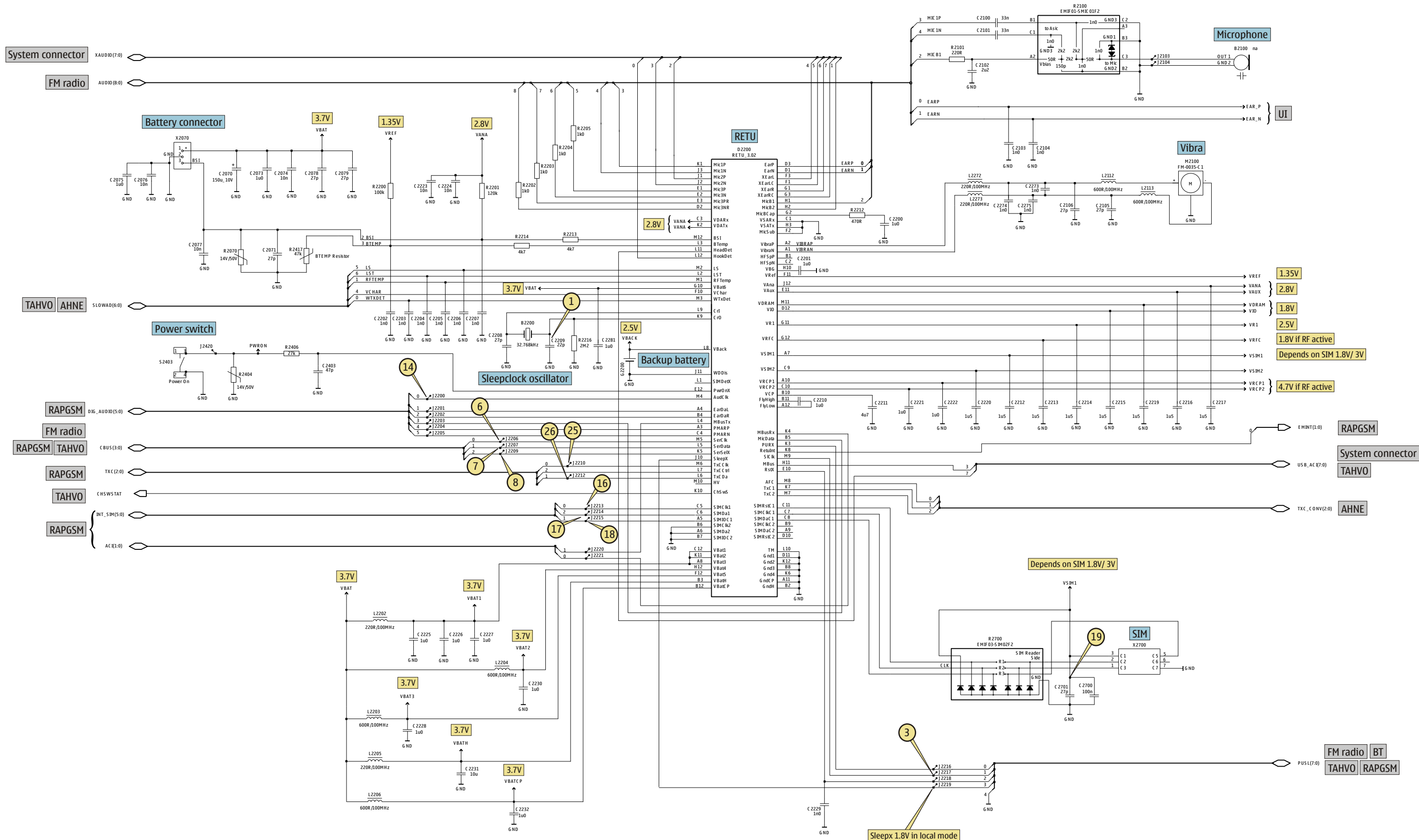

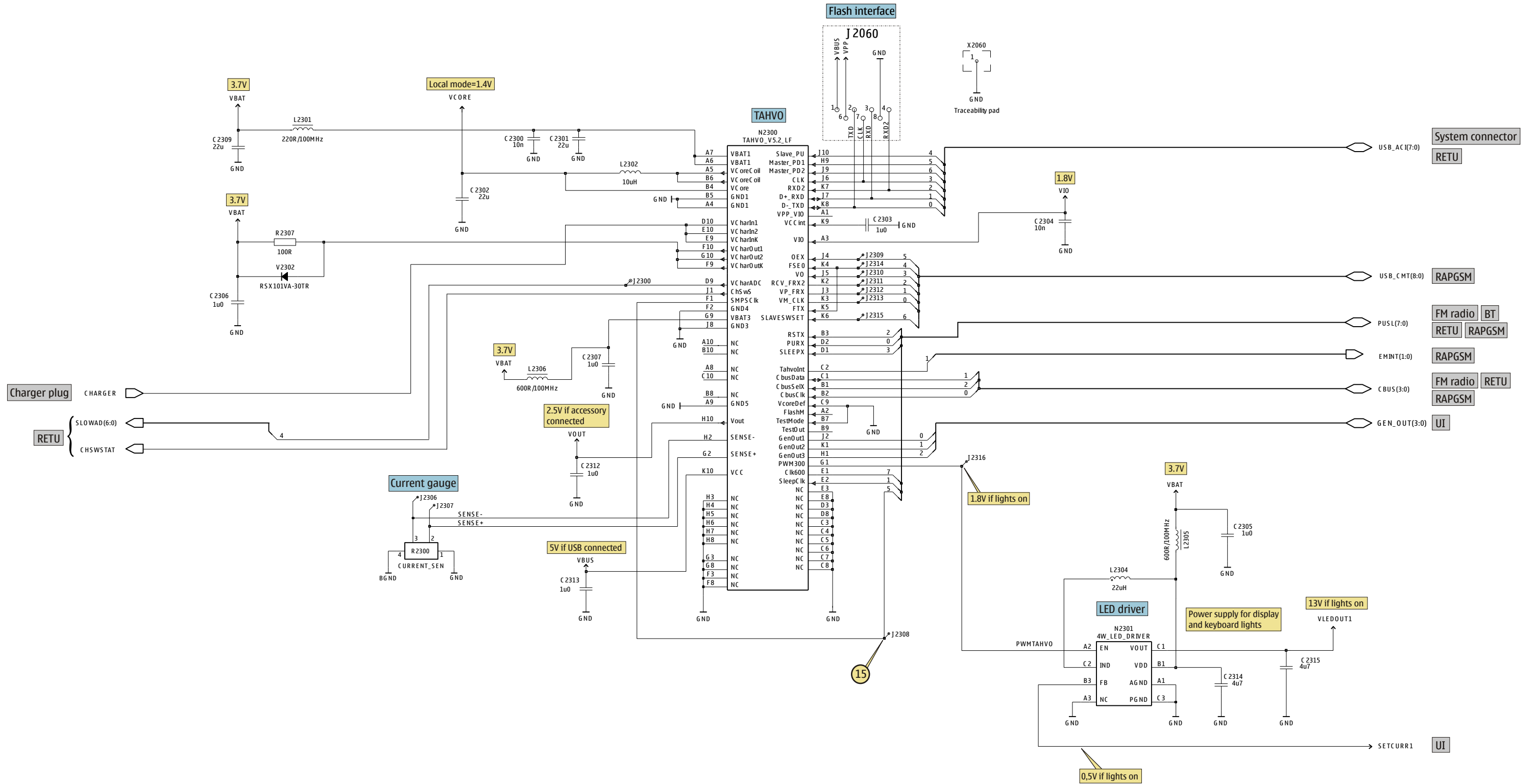

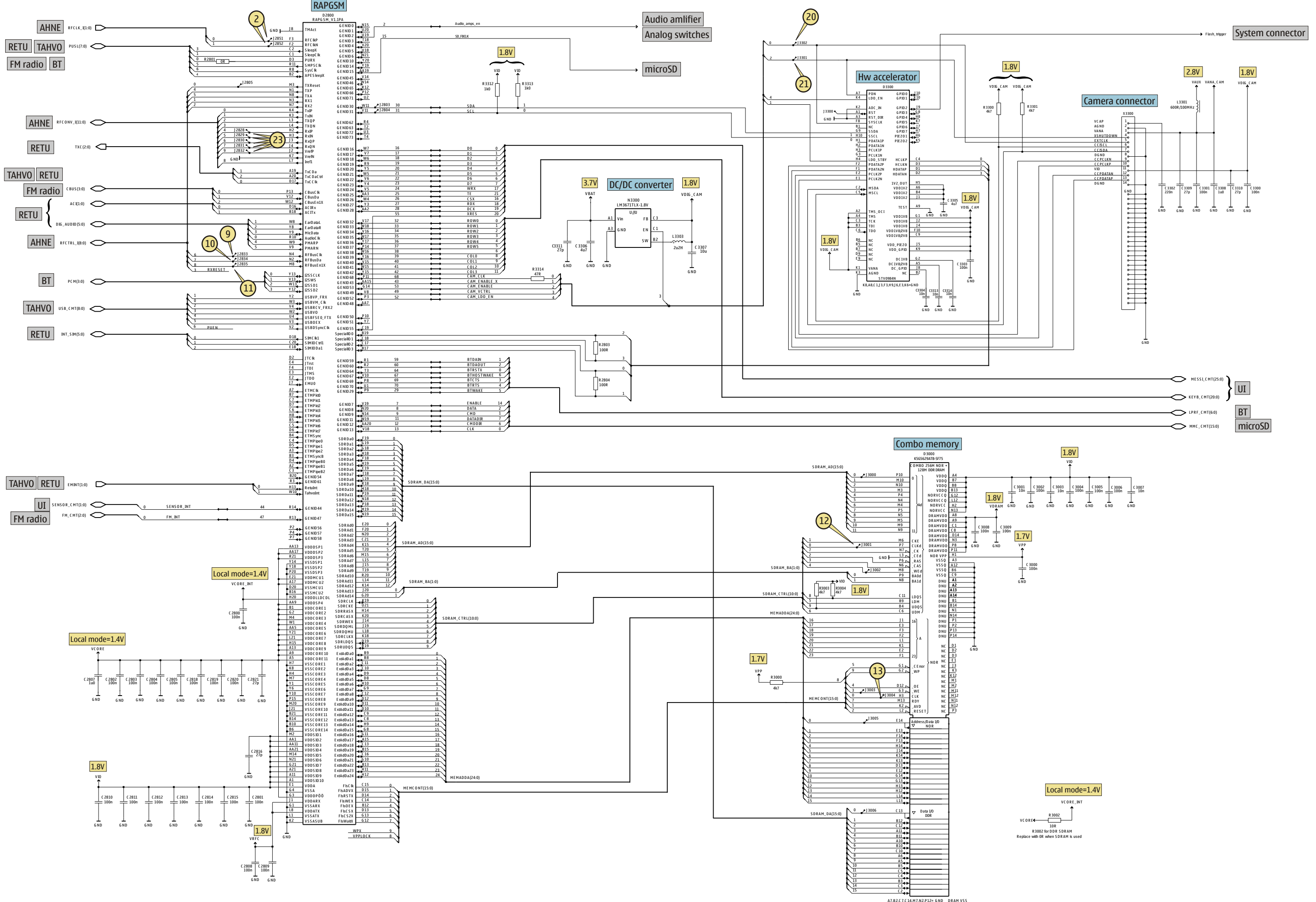

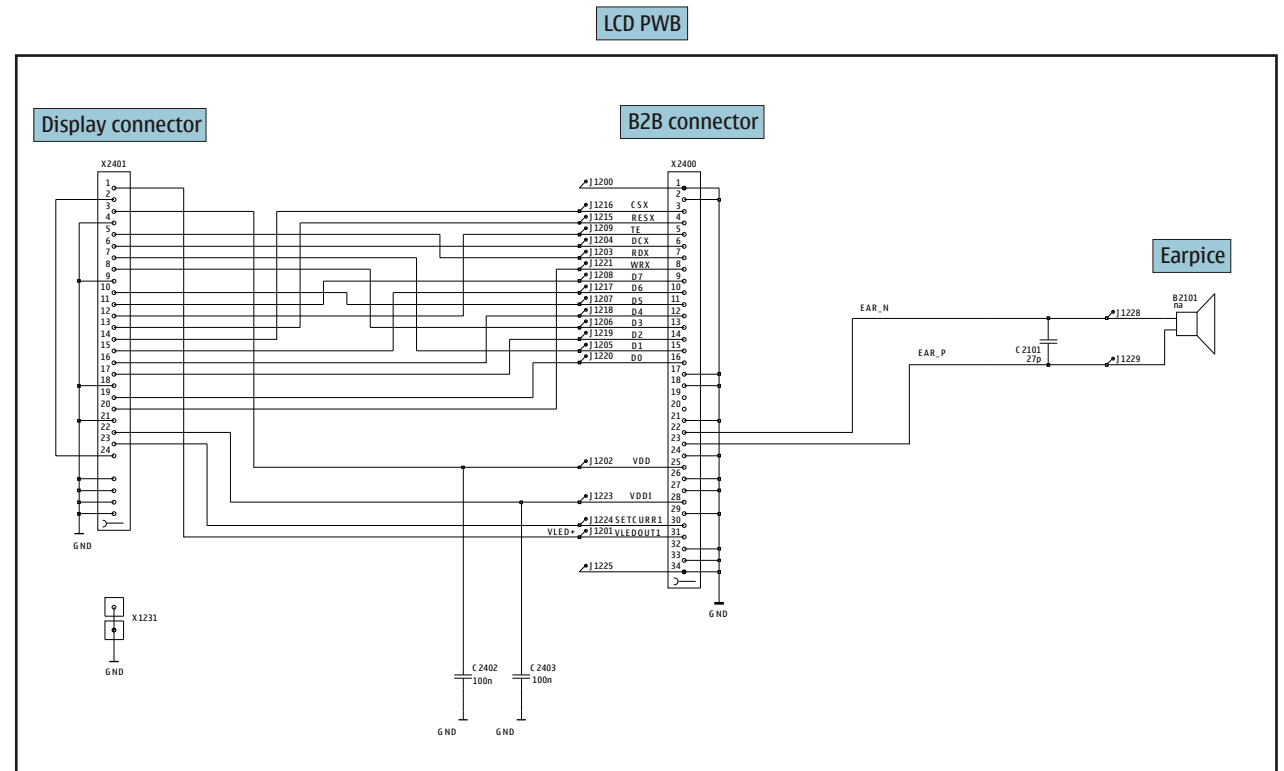
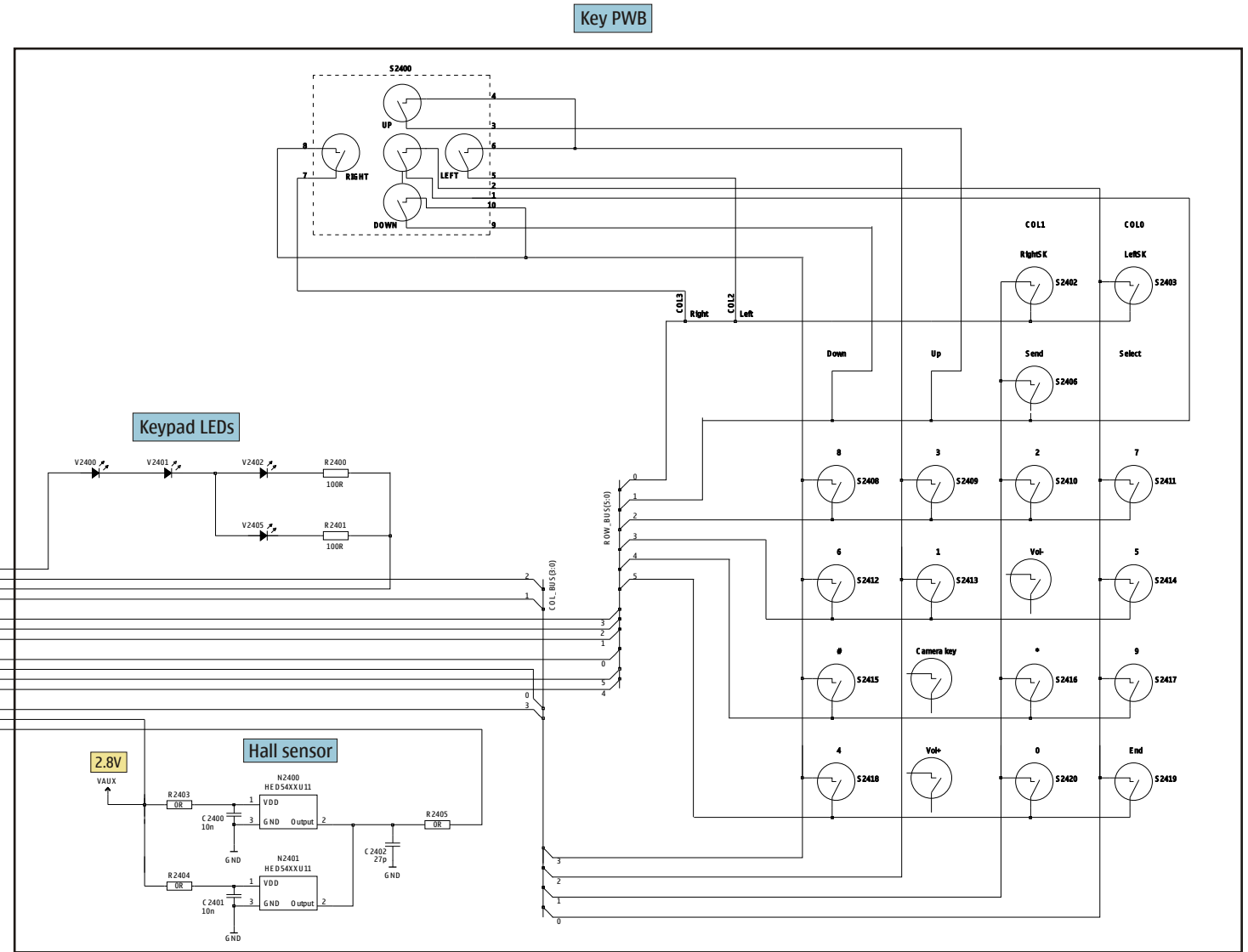
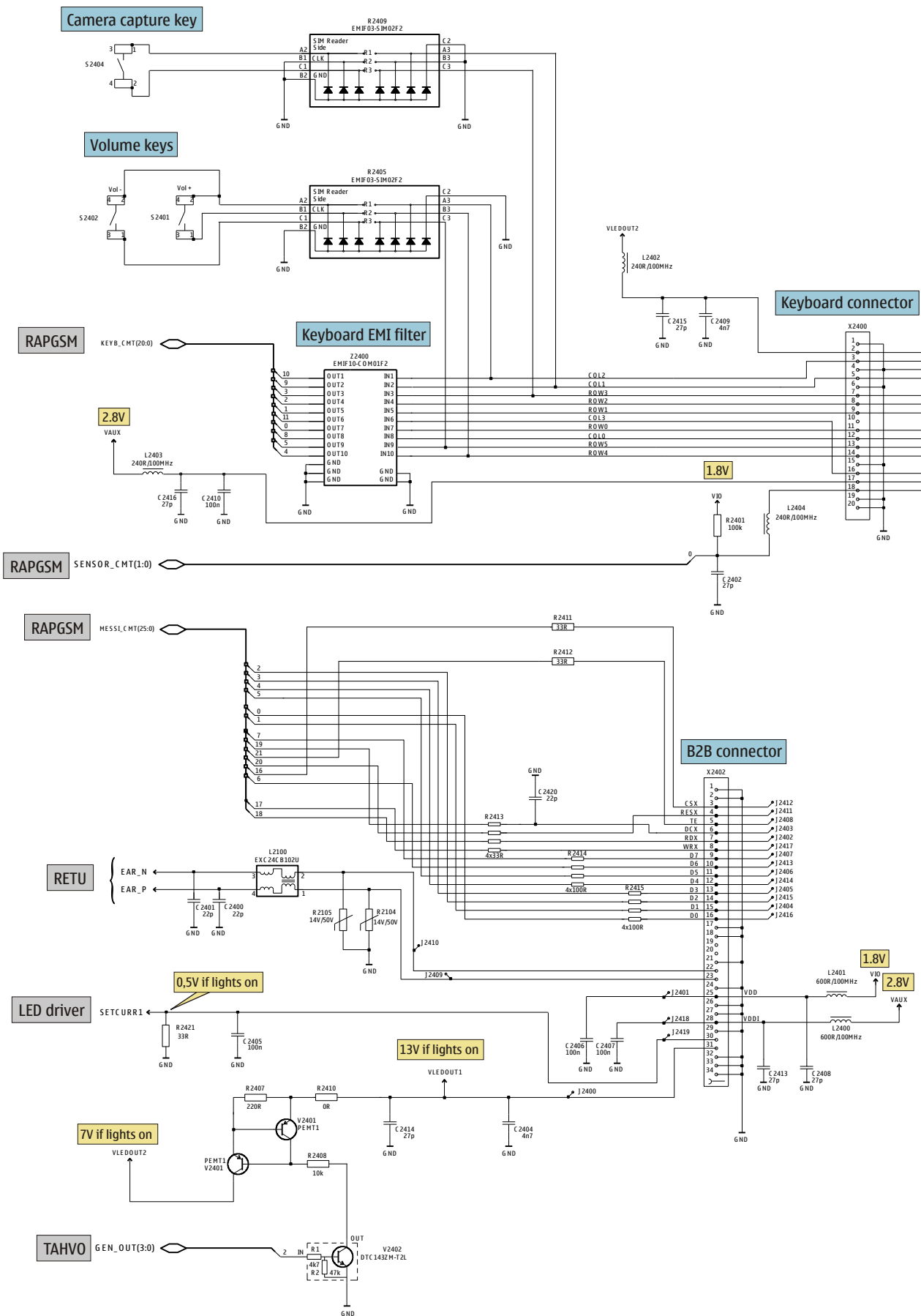

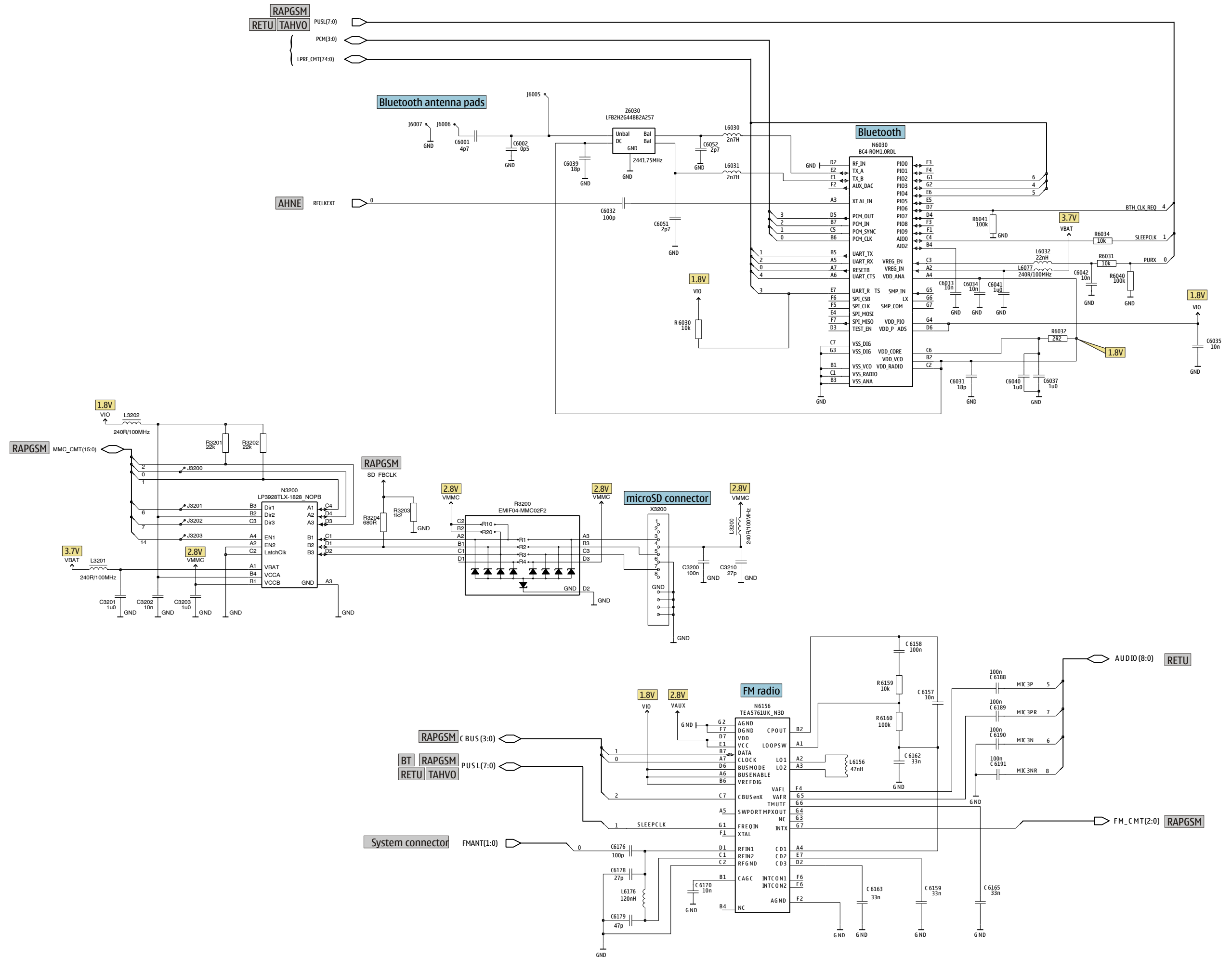

Band	Channel	RX	VCO/RX	VC/RX	TX	VCO/TX	VC/TX
GSM 900	37	942.4MHz	3769.6MHz	~2.73V	897.4MHz	3589.6MHz	~1.99V
GSM 1800	700	1842.8MHz	3685.6MHz	~2.39V	1747.8MHz	3495.6MHz	~1.60V
GSM 1900	661	1960.0MHz	3920.0MHz	~3.31V	1880.0MHz	3760.0MHz	~2.69V

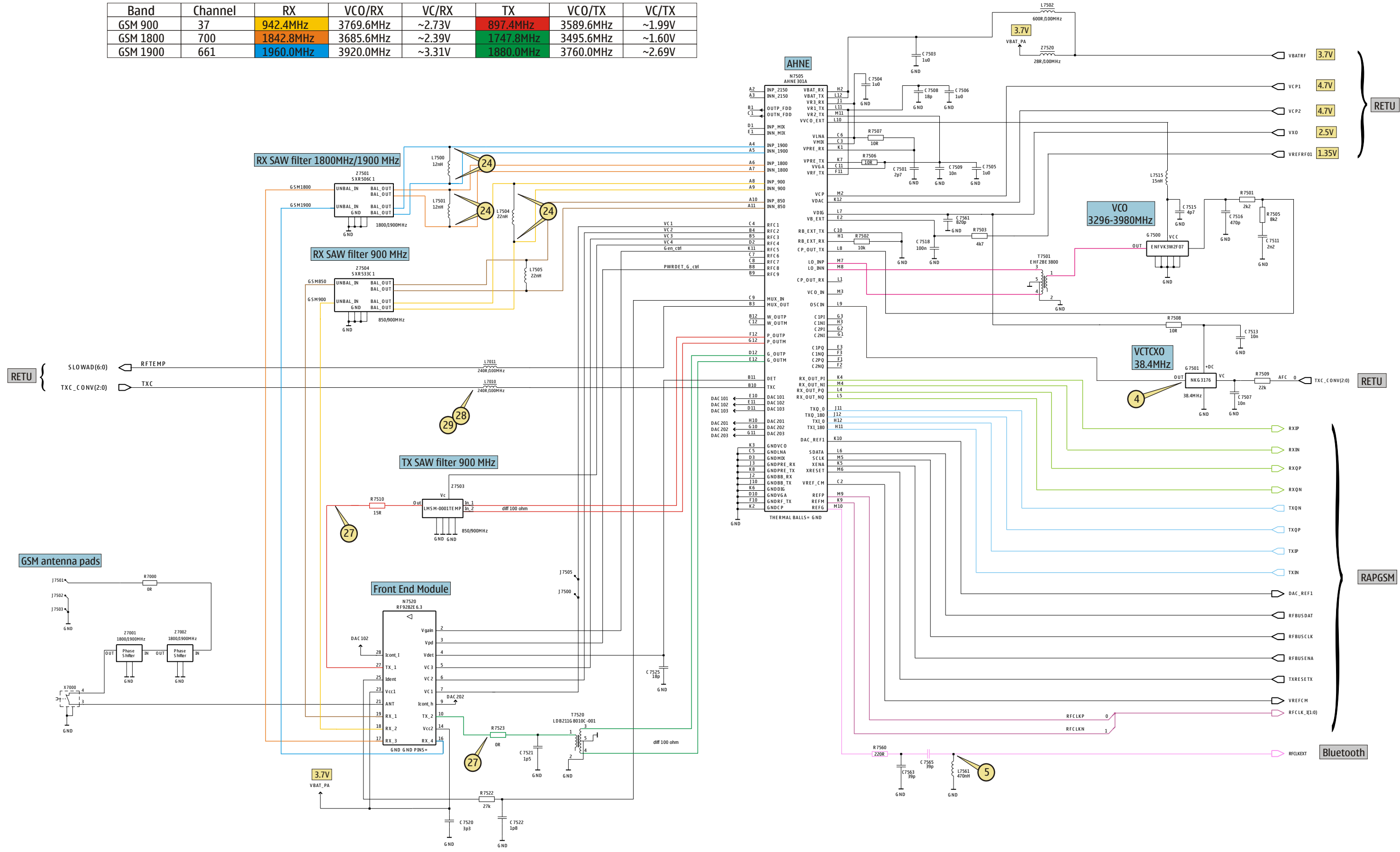

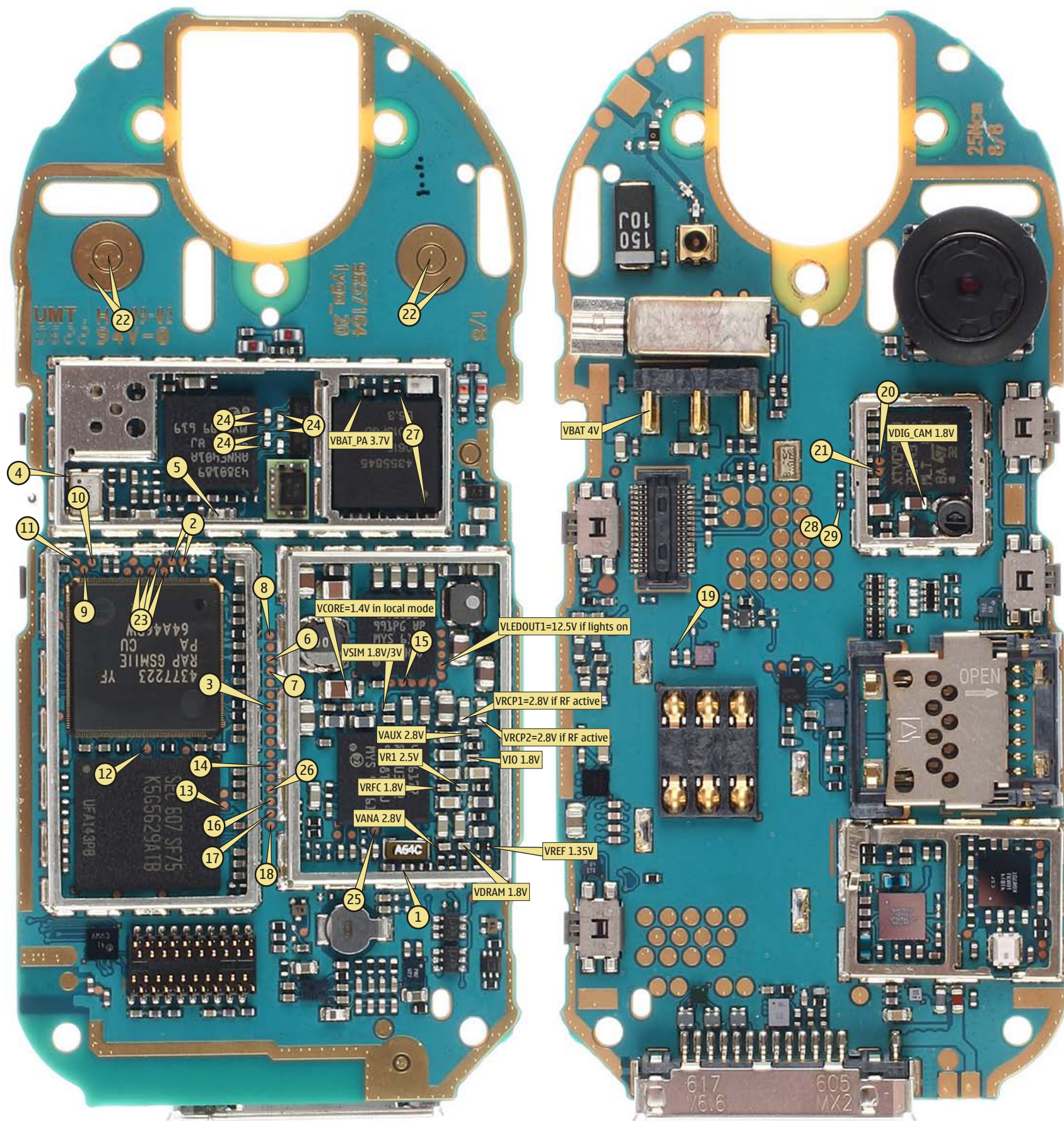
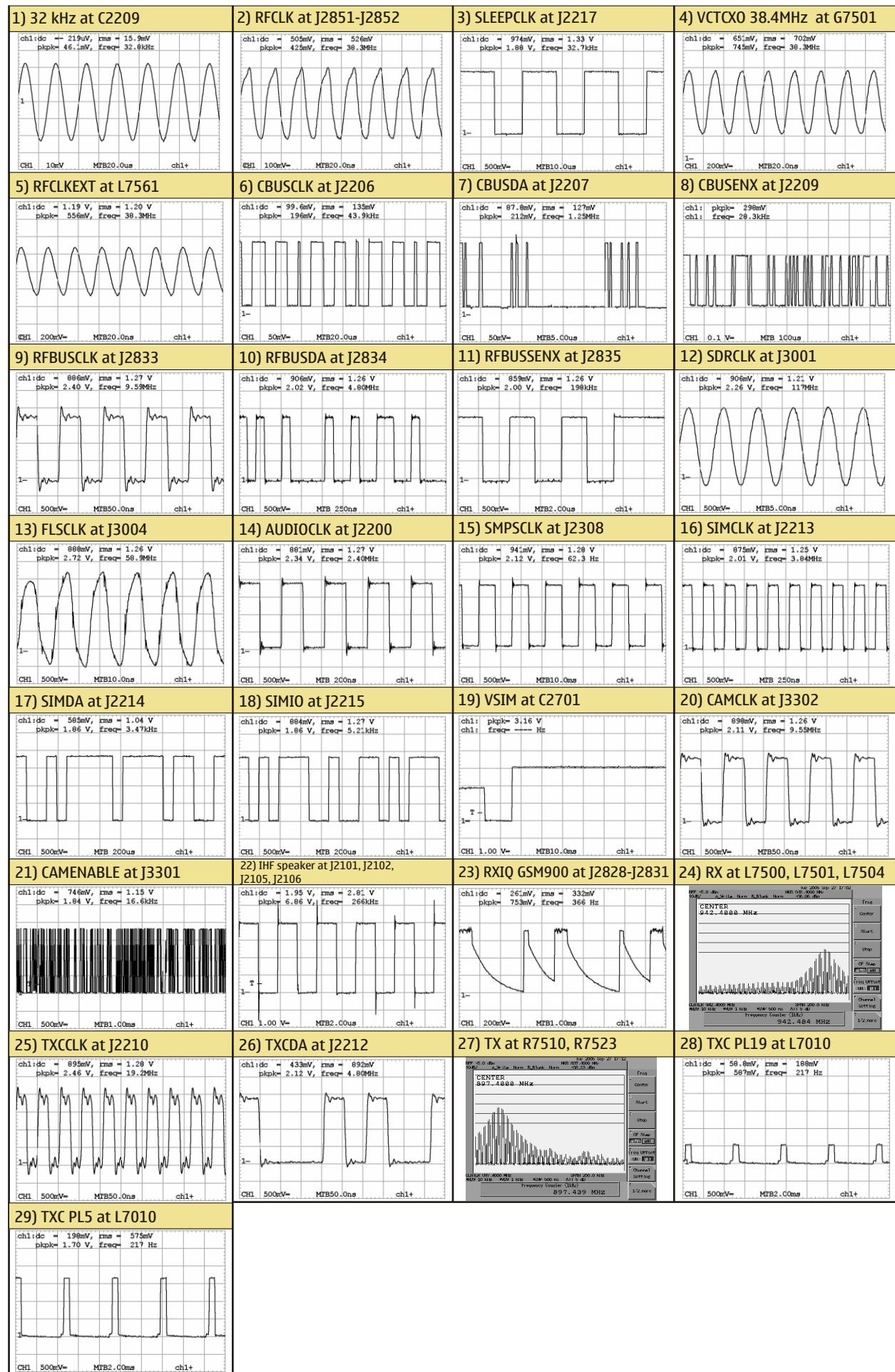

B	C2213	M8	C2816	M5	C7505	I3	J2306	F7	T6002	N2	N6030	O2	R3300	H3	
B2100	Q7	C2214	M8	C2818	M3	C7506	I3	J2307	F6	T6003	P2	N6156	O4	R3301	H3
B2102	E3	C2215	M8	C2819	M4	C7507	I3	J2308	L7	T6004	N2	N7505	H4	R3306	H3
B2103	E8	C2216	L8	C2820	J3	C7508	I4	J2309	K8	T6005	O3	N7520	H7	R3307	H3
B2200	N7	C2217	N8	C2821	J3	C7509	H3	J2310	K8	L	R			R3312	O5
C	C2218	N7	C2830	J4	C7511	H3	J2311	L8	L2000	P3	R2000	P5	R3313	O5	
C2000	P4	C2219	N8	C2831	J4	C7513	I3	J2312	K8	L2001	Q6	R2001	P6	R3314	M2
C2001	P4	C2220	L7	C3000	N2	C7515	G3	J2313	L8	L2002	Q7	R2002	P7	R6030	N3
C2002	P6	C2221	L9	C3001	N2	C7516	H3	J2314	K8	L2003	Q7	R2003	P7	R6031	O2
C2003	P6	C2222	L8	C3002	N2	C7518	I4	J2315	K8	L2004	Q6	R2004	P7	R6032	N2
C2004	P6	C2223	L6	C3003	M5	C7520	G7	J2316	L7	L2100	K6	R2005	P7	R6034	O3
C2005	P6	C2224	N6	C3004	M5	C7521	G7	J2400	I6	L2102	F6	R2006	P7	R6040	O2
C2006	P6	C2225	N8	C3005	N5	C7522	I7	J2401	I6	L2103	F5	R2007	Q6	R6041	K4
C2007	P7	C2226	M8	C3006	N5	C7523	G7	J2402	I6	L2104	K9	R2008	P6	R6156	O3
C2008	P7	C2227	L7	C3007	N5	C7524	I6	J2403	I5	L2105	K9	R2009	P6	R6159	N4
C2009	P7	C2228	M8	C3008	M5	C7525	I8	J2404	J6	L2106	L9	R2010	P5	R6160	N4
C2010	P7	C2229	L7	C3009	N5	C7560	H2	J2405	J5	L2107	L8	R2017	O8	R6161	P4
C2011	P7	C2230	N8	C3100	K6	C7561	H3	J2406	J6	L2108	G8	R2070	H6	R7000	C8
C2012	P7	C2231	L6	C3200	M5	C7562	I5	J2407	J5	L2109	G9	R2100	P7	R7501	H3
C2013	P7	C2232	L8	C3201	L6	C7563	I4	J2408	I6	L2111	L9	R2101	Q8	R7502	G4
C2014	P7	C2273	L6	C3202	L5	C7564	G3	J2409	J6	L2112	G6	R2102	O7	R7503	I4
C2015	P6	C2274	L7	C3203	L6	C7565	I4	J2410	J6	L2113	G6	R2103	O7	R7505	H3
C2016	P5	C2275	L6	C3210	M5	C7566	H3	J2411	I5	L2202	M9	R2104	K6	R7506	H4
C2017	Q4	C2281	M8	C3300	I4	D	J2413	J5	L2203	M9	R2105	J6	R7507	G4	
C2018	P5	C2300	J6	C3301	F4	D2200	M7	J2414	J6	L2204	N8	R2106	G6	R7508	H3
C2019	P6	C2301	J6	C3302	G4	D2800	K3	J2415	J5	L2205	N9	R2107	G5	R7509	I3
C2020	O8	C2302	L6	C3303	I4	D3000	N3	J2416	J6	L2206	M8	R2114	G8	R7510	I7
C2070	E8	C2303	J8	C3304	H4	D3300	H4	J2417	I5	L2272	L7	R2115	G9	R7522	I7
C2071	H7	C2304	L7	C3305	I4	F	J2418	I6	L2273	L6	R2200	N9	R7523	G7	
C2072	O6	C2305	J9	C3306	I4	F2000	P3	J2419	I6	L2301	J6	R2201	N8	R7560	I5
C2073	H8	C2306	I9	C3307	I4	G	J2420	J8	L2302	K6	R2202	M6	S		
C2074	G8	C2307	J7	C3308	H4	G2200	O6	J2803	K2	L2304	J8	R2203	N6	S2401	H2
C2075	H7	C2309	J6	C3309	G4	G7500	G3	J2804	K2	L2305	J8	R2204	N6	S2402	J2
C2076	H7	C2312	J7	C3310	I4	G7501	I2	J2828	J4	L2306	I8	R2205	N6	S2403	I9
C2077	H6	C2313	J7	C3311	I4	J	J2829	J4	L2400	H6	R2206	N6	S2404	O9	
C2078	E8	C2314	K8	C3313	I4	J2000	Q3	J2830	J3	L2401	H6	R2207	N6	T	
C2079	H8	C2315	K9	C3314	H4	J2001	P7	J2831	J3	L2402	Q4	R2208	N6	T7501	H3
C2100	P8	C2400	K7	C6001	P3	J2003	P6	J2833	J2	L2403	Q5	R2209	N6	T7520	G8
C2101	P7	C2401	J7	C6002	P3	J2004	P8	J2834	J3	L2404	O5	R2212	M6	V	
C2102	P8	C2402	P5	C6031	P2	J2005	P5	J2835	J2	L3200	L5	R2213	N8	V2000	P4
C2103	O7	C2403	J8	C6032	N3	J2006	P7	J2851	J4	L3201	L6	R2214	N8	V2001	O6
C2104	O7	C2404	I7	C6033	N3	J2010	R3	J2852	J4	L3202	L5	R2216	N8	V2302	I8
C2105	H6	C2405	I7	C6034	O3	J2011	O6	J3000	O4	L3301	H4	R2307	H8	V2401	P9
C2106	G6	C2406	I7	C6035	N2	J2060	O7	J3001	M3	L3303	I3	R2401	O5	V2402	O9
C2107	G8	C2407	I7	C6036	N3	J2100	O8	J3002	L2	L6030	O2	R2404	J9	X	
C2108	K9	C2408	H7	C6037	N2	J2101	E3	J3003	O3	L6031	O2	R2405	J9	X2000	Q3
C2109	K9	C2409	Q3	C6039	O3	J2102	E3	J3004	M5	L6032	O2	R2406	J9	X2001	Q6
C2110	K9	C2410	Q4	C6040	N2	J2103	Q7	J3005	M5	L6077	P3	R2407	P9	X2060	H6
C2111	F5	C2413	H6	C6041	P3	J2104	Q7	J3006	M4	L6156	O4	R2408	N9	X2070	G7
C2112	K8	C2414	I7	C6042	O2	J2105	E8	J3112	O6	L6176	P5	R2409	N9	X2400	P4
C2113	K9	C2415	Q4	C6051	O2	J2106	E8	J3113	P7	L7000	C8	R2410	J8	X2402	I8
C2114	K9	C2416	Q5	C6052	O3	J2200	M5	J3114	P8	L7001	C8	R2411	J3	X2700	M7
C2117	N8	C2418	K3	C6157	N4	J2201	L5	J3115	O7	L7010	I5	R2412	J3	X2705	K8
C2118	M8	C2419	J3	C6158	N4	J2202	L5	J3116	P7	L7011	I5	R2413	J3	X2706	N8
C2119	N8	C2420	J4	C6159	P3	J2203	L5	J3117	P7	L7500	H5	R2414	J4	X2707	M5
C2120	N8	C2700	K7	C6162	N4	J2204	N6	J3200	K5	L7501	H5	R2415	K4	X2708	O5
C2124	M9	C2701	K7	C6163	O5	J2205	N7	J3201	K6	L7502	I4	R2417	P6	X3200	L3
C2126	N9	C2800	L5	C6164	O3	J2206	K5	J3202	L5	L7503	I7	R2421	K8	X3300	F3
C2127	M8	C2801	J4	C6165	P3	J2207	K5	J3203	K6	L7504	H5	R2700	K7	X7000	E7
C2200	M6	C2802	K5	C6167	O5	J2209	K5	J3300	I3	L7505	H5	R2701	K7	Z	
C2201	M8	C2803	L5	C6170	O5	J2210	N7	J3301	H4	L7515	G3	R2801	K5	Z2000	Q5
C2202	N9	C2804	J5	C6176	P4	J2212	M5	J3302	H4	L7561	I5	R2803	L5	Z2001	Q6
C2203	N7	C2805	M2	C6178	O5	J2213	M5	J6005	P3	M	R2804	L5	Z2003	Q5	
C2204	N7	C2807	J5	C6179	O5	J2214	N5	J6006	P2	M2100	F7	R3000	M2	Z2400	O3
C2205	N6	C2808	J5	C6188	P4	J2215	N5	J6007	P2	N	R3002	K5	Z6030	P2	
C2206	N7	C2809	K5	C6189	P4	J2216	L5	J7500	H8	N2000	O8	R3003	M3	Z7001	D7
C2207	N8	C2810	L5	C6190	N4	J2217	L5	J7501	C8	N2001	P8	R3004	M4	Z7002	D7
C2208	N7	C2811	M2	C6191	N3	J2218	K5	J7502	C8	N2101	M9	R3200	L5	Z7501	G6
C2209	N7	C2812	K5	C7501	G4	J2219	L5	J7503	B8	N2300	K7	R3201	K5	Z7503	I6
C2210	L8	C2813	J2	C7502	I4	J2220	M5	J7505	H8	N2301	K9	R3202	K6	Z7504	H6
C2211	L8	C2814	J5	C7503	I3	J2221	M5	T6000	N2	N3200	L6	R3203	M5	Z7520	G6
C2212	L7	C2815	L5	C7504	G4	J2300	L7	T6001	P2	N3300	I4	R3204	M5		

