

Service schematics

Nokia Asha 302

RM-813

20.01.2012

v1.0



IMPORTANT

This document is intended for use by authorized Nokia service centers only. Please use the document together with other documents such as the Service Manual and Service Bulletins.

Version information

While every effort has been made to ensure that the document is accurate, some errors may exist. Please always check for the latest published version for this document.

If you find any errors in the document please send email to: service.manuals@nokia.com

1.0 First approved version.

Contents

- 1 Front page
- 2 RAPUYAMA, BOB, Combo mem, Camera, Display, Backlighting, MIC
- 3 PEARL, Charging, SIM, μ SD card, KB backlighting
- 4 PEARL, USB, AV connector, Audio
- 5 UI interface
- 6 RF part
- 7 Component finder top
- 8 Component finder bottom

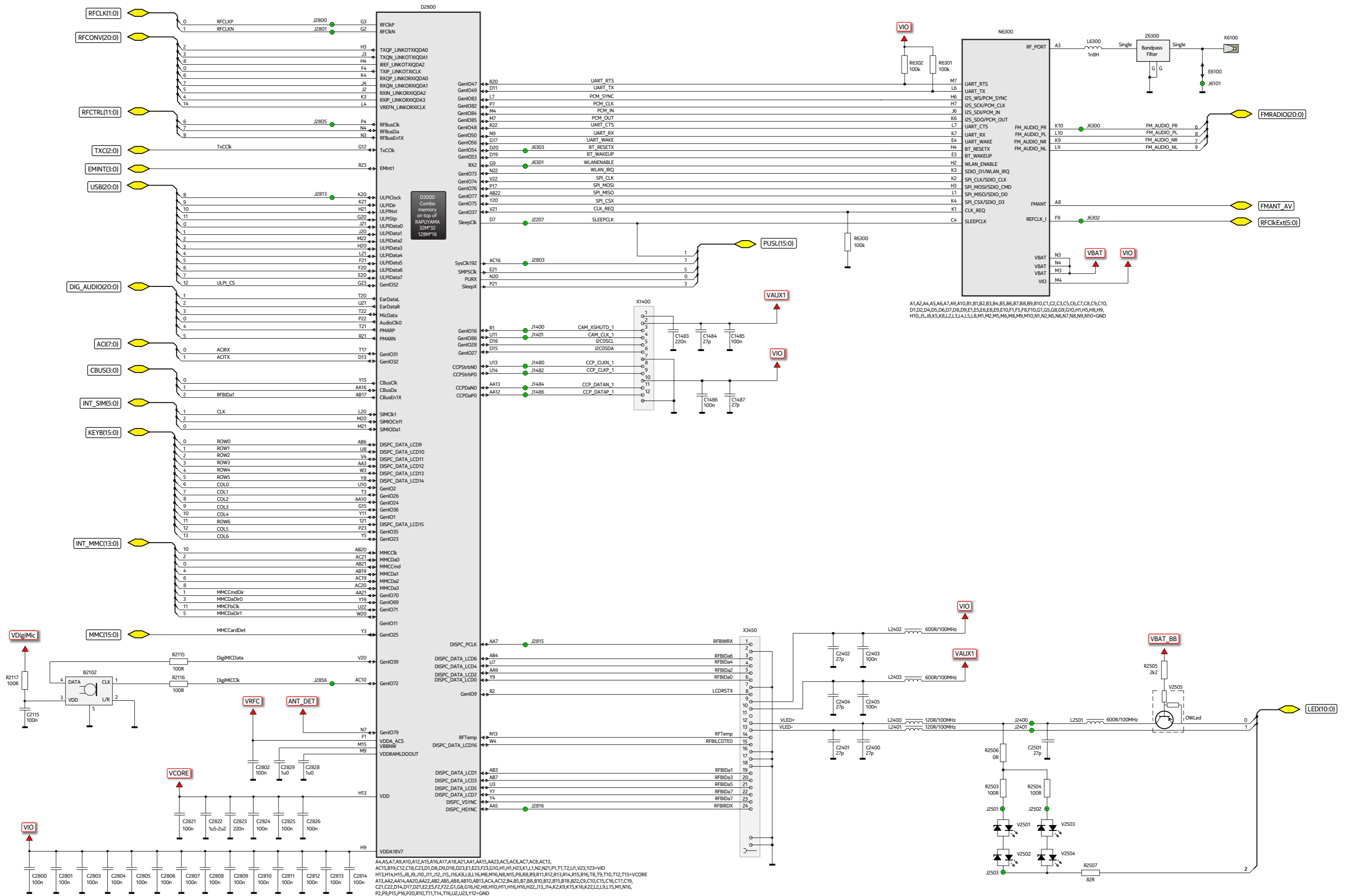

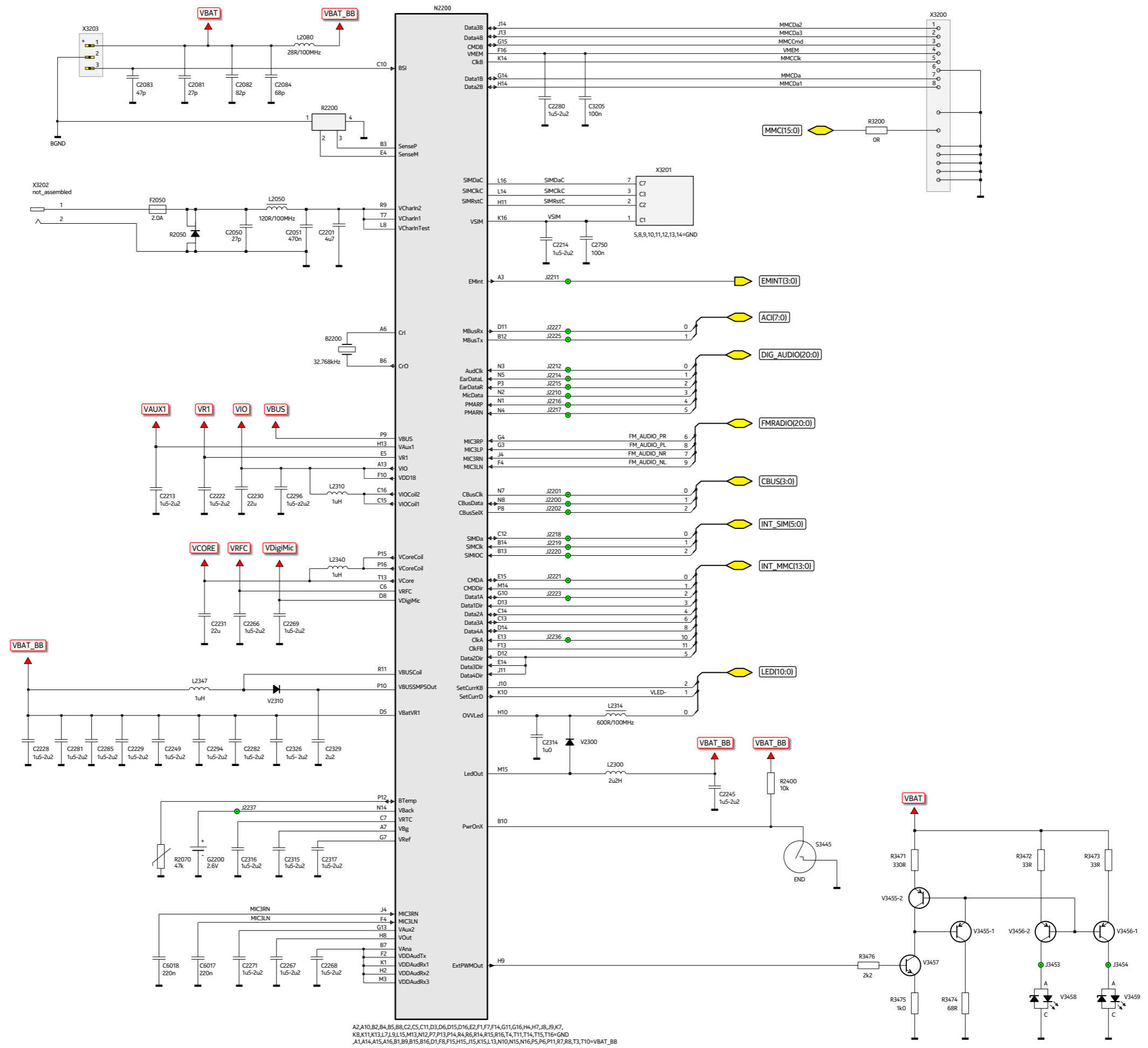

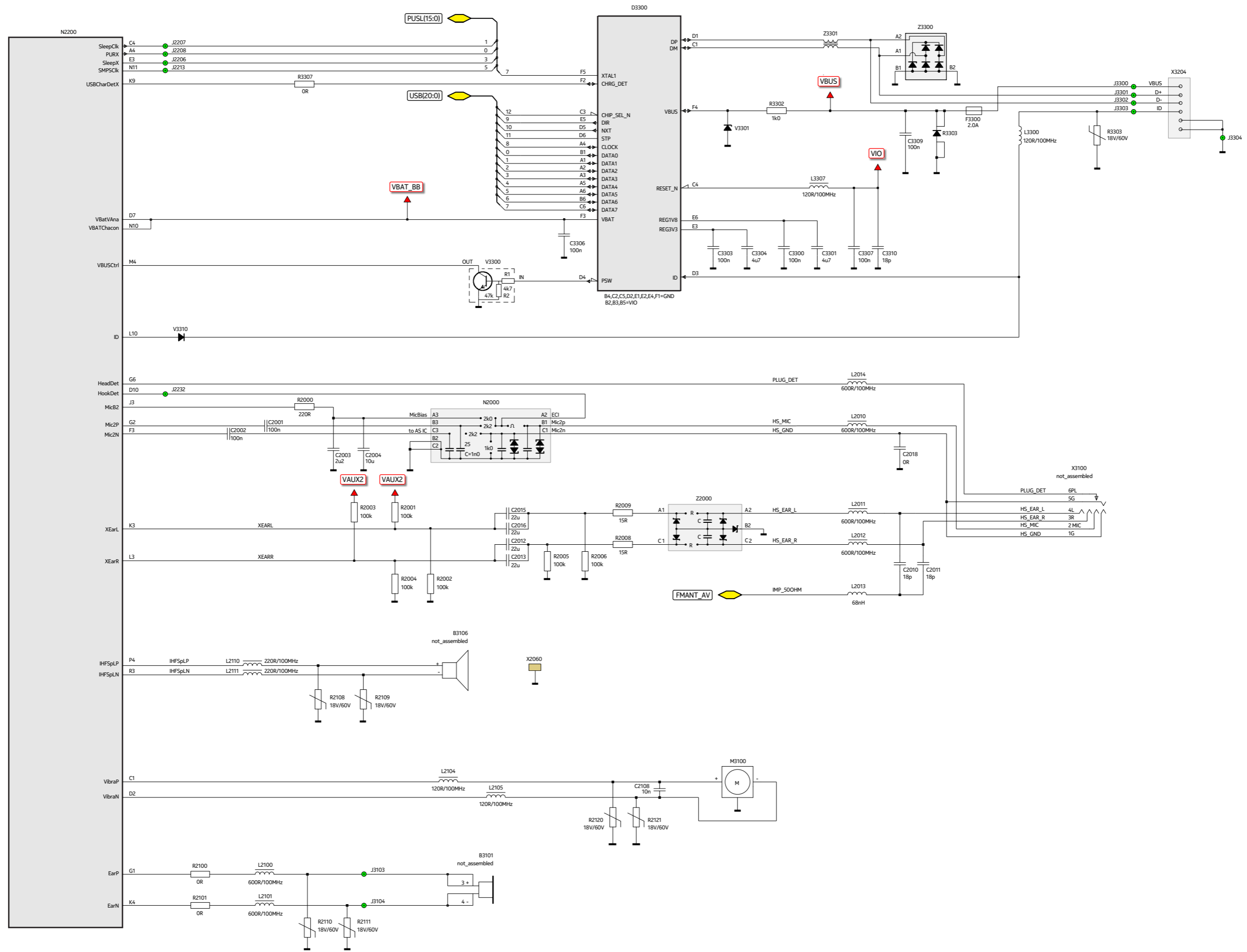

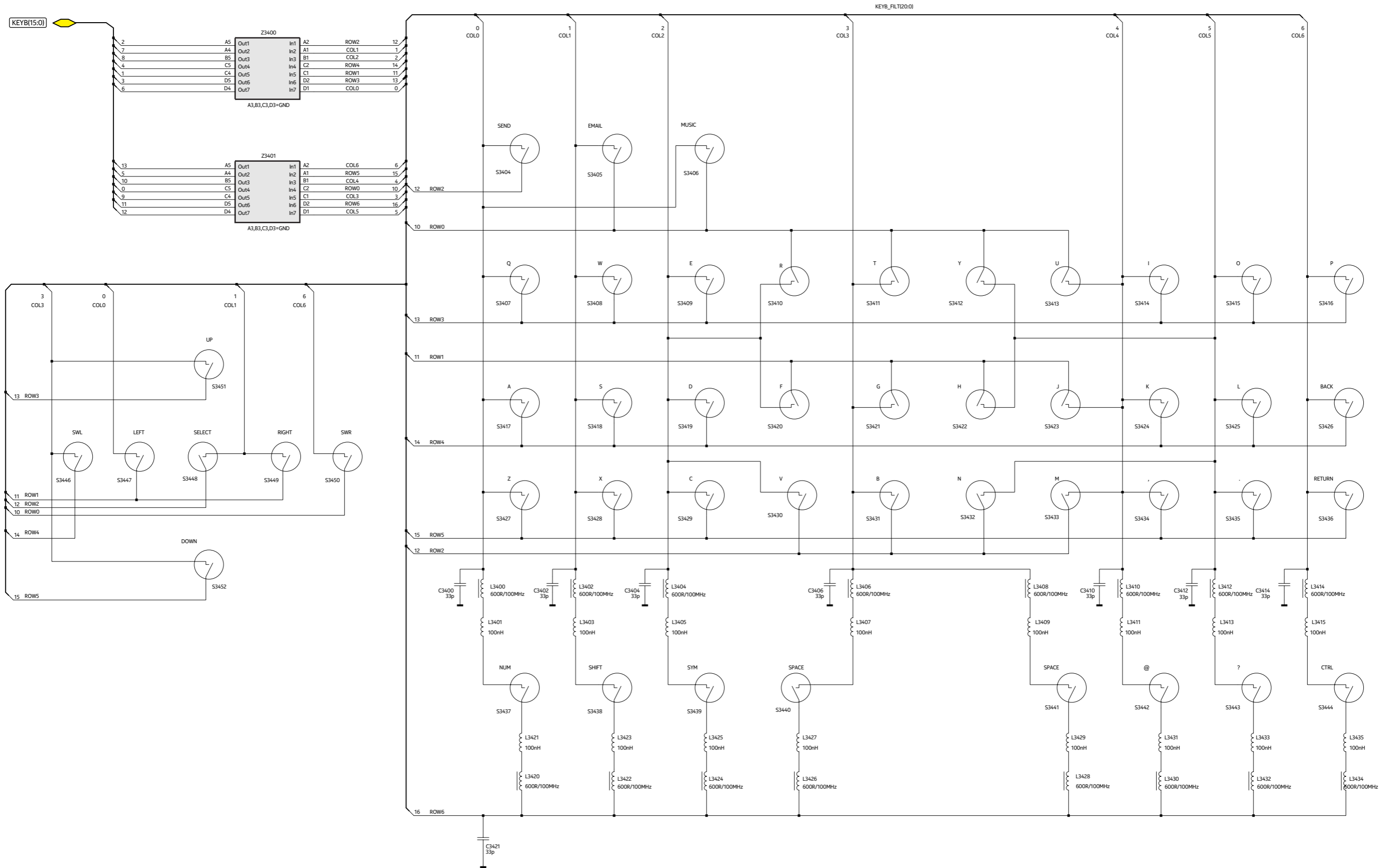

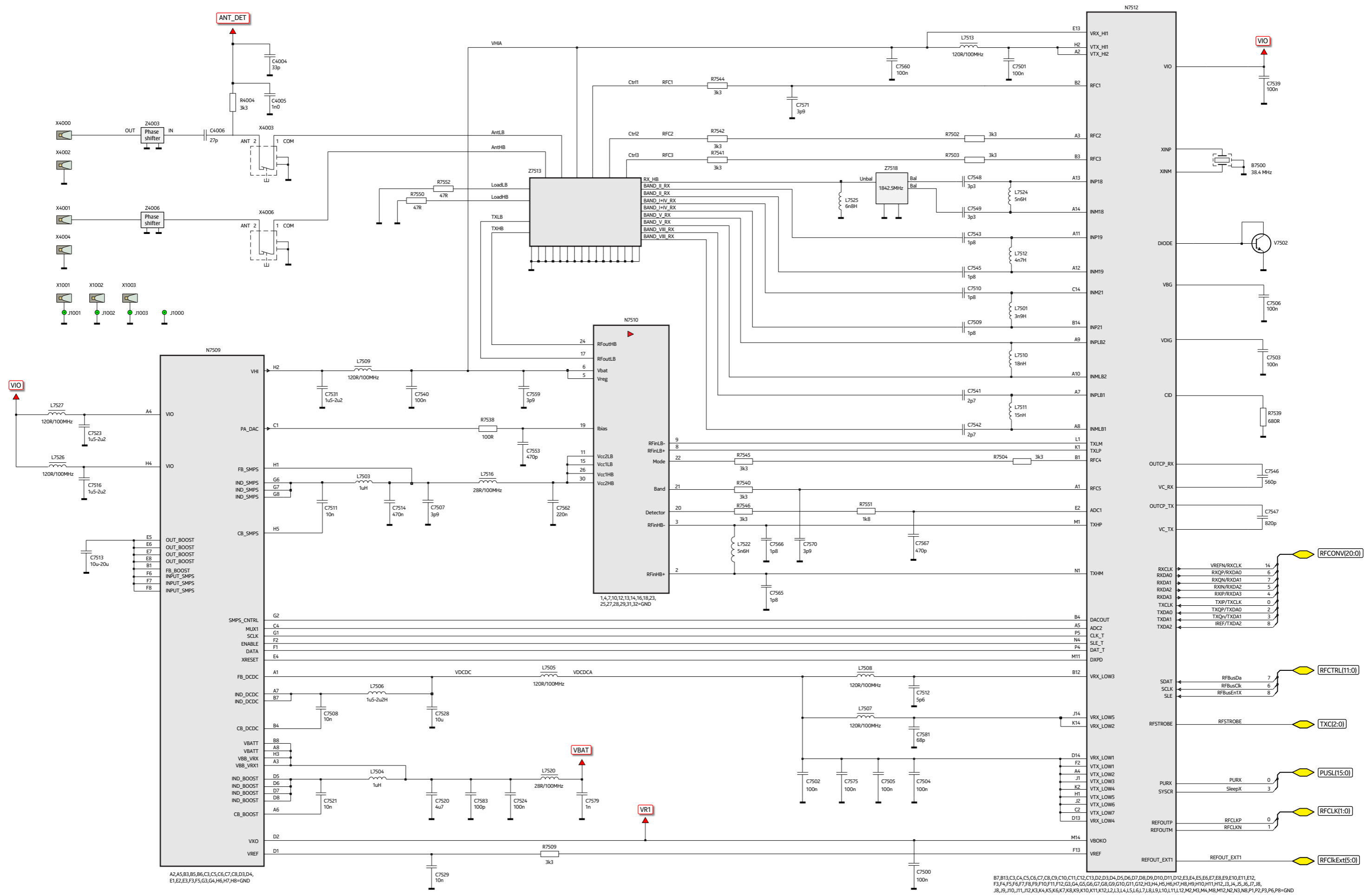

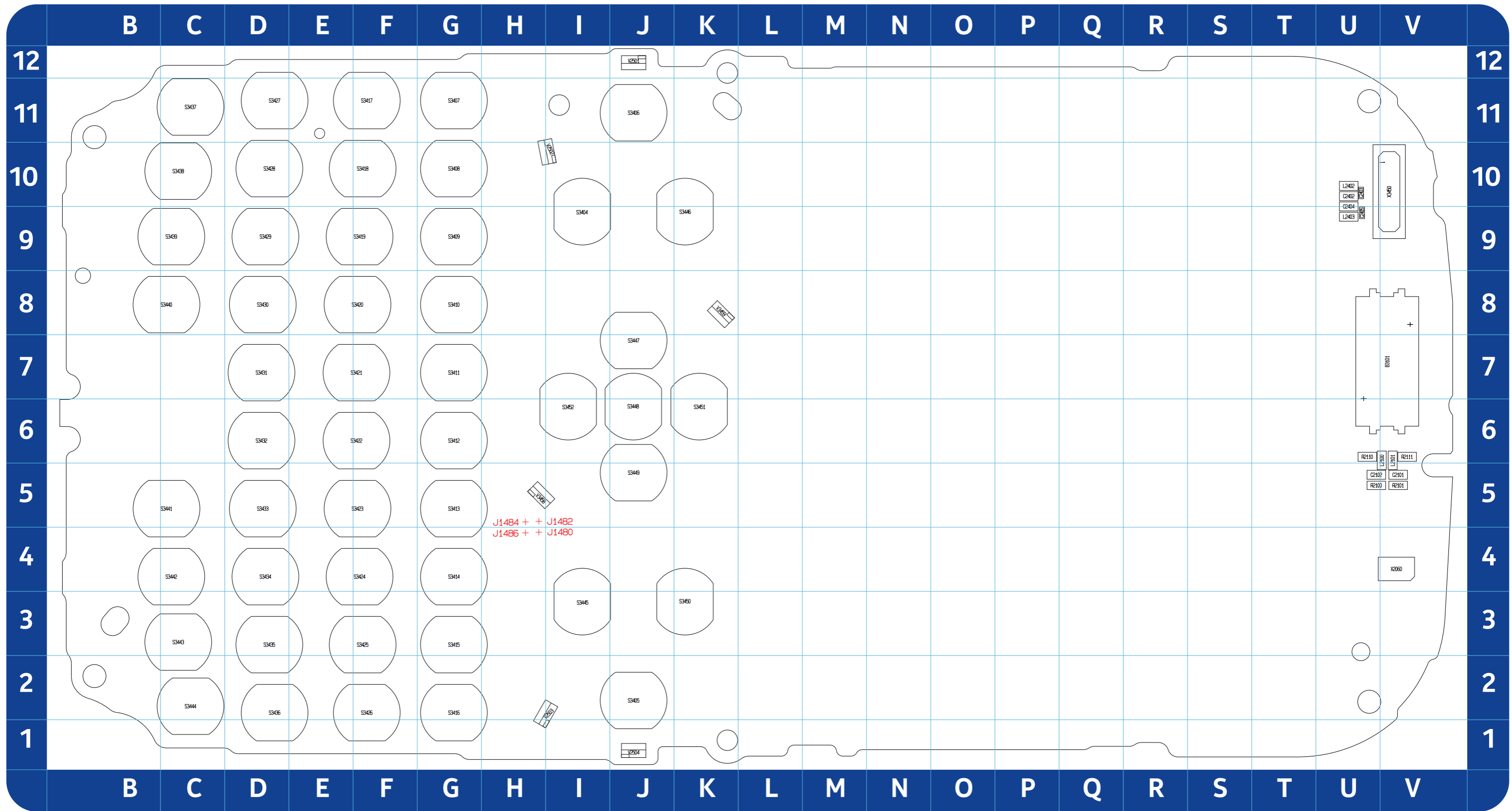

B	L	V
B3101 V7	L2101 V6	V2501 J12
C	L2402 U10	V2502 I10
C2402 U10	L2403 U9	V2503 H2
C2403 U10	R	V2504 J1
C2404 U9	R2100 U5	V3458 H5
C2405 U9	R2101 V5	V3459 K8
L	R2110 U6	X2060 V4
L2100 V6	R2111 V6	X3450 V10

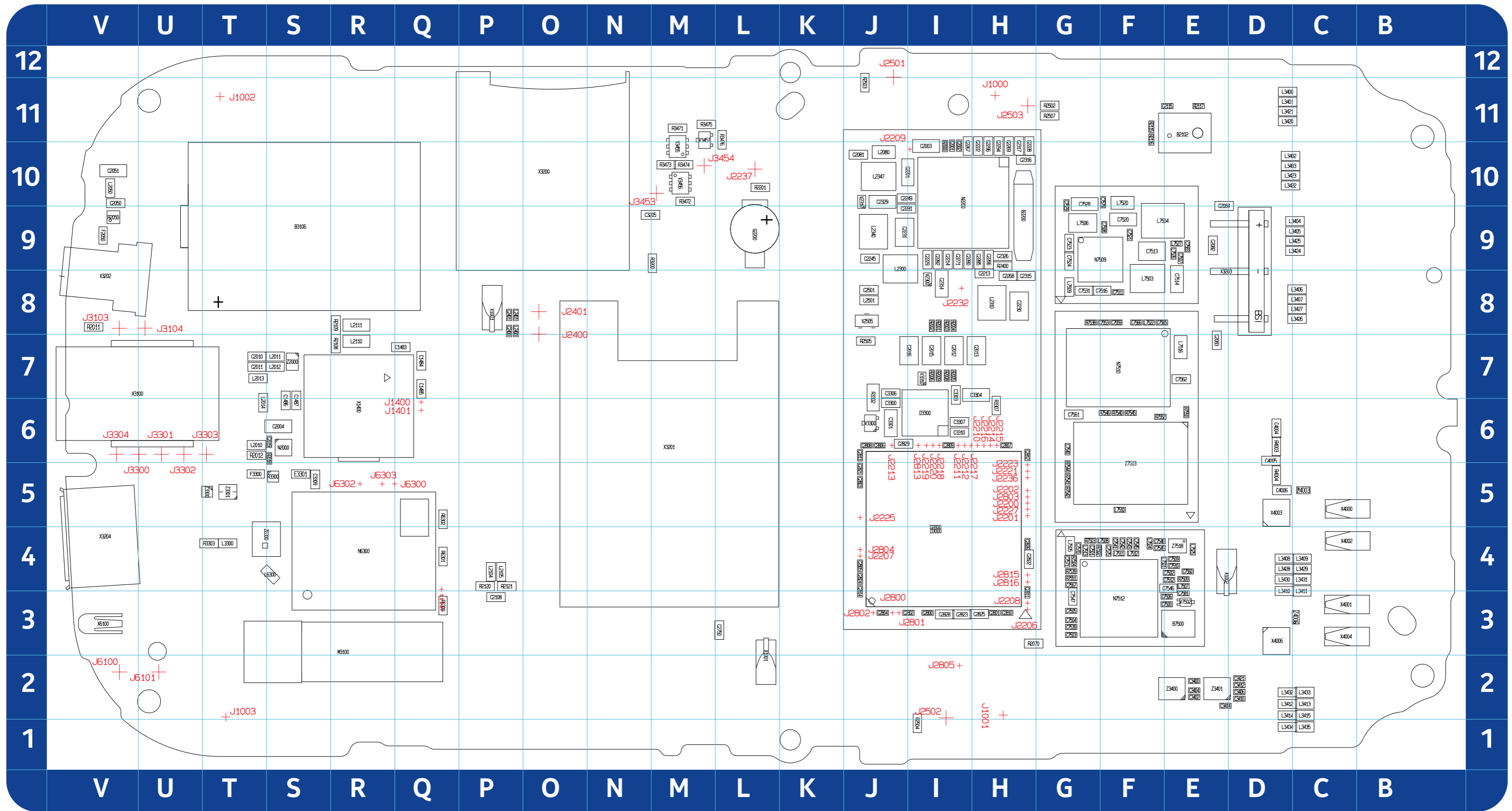

B	C2002	I10	C2080	G10	C2229	I9	C2282	I9	C2501	J8	C2809	I6	C2828	I3	C3311	S5	C4006	D5	C7511	F8	C7539	G3	C7560	E4	D	L2012	S7	L2347	J10	L3407	C8	L3423	D10	L3435	C1	L7512	F4	N2000	S6	R2005	I7	R2117	E11	R3303	T4	R7502	G4	R7550	E6	V7502	E3	X4000	C5	Z3401	E2		
B2102	E11	C2003	I10	C2081	J10	C2230	H8	C2285	H9	C2750	L3	C2810	H3	C2829	J6	C3400	E2	C7500	E3	C7512	E4	C7540	G6	C7561	G6	D2800	I4	L2013	T7	L2400	P8	L3408	D4	L3424	C9	L6300	S4	L7513	G4	N2200	I10	R2006	I7	R2120	P4	R3307	H6	R7503	G4	R7551	G4	X	X4001	C3	Z4003	C5	
B2200	H9	C2004	S6	C2082	E9	C2231	J9	C2294	H10	C2751	L3	C2811	H3	C3205	N9	C3402	E2	C7501	G4	C7513	F9	C7541	F4	C7562	E7	D3000	I4	L2014	T6	L2401	P8	L3409	C4	L3425	C9	L7501	F4	L7516	E7	N6300	R4	R2008	I7	R2121	P4	R3471	M11	R7504	G4	R7552	F6	X1001	L2	X4002	C3	Z4006	C4
B3106	S9	C2010	T7	C2083	E7	C2245	J9	C2296	H10	C2800	I3	C2812	H6	C3300	J6	C3404	E2	C7502	E4	C7514	E8	C7542	F4	C7565	F8	D3300	I6	L2050	V10	L2501	J8	L3410	D3	L3426	C8	L7503	F8	L7520	F10	N7509	F9	R2009	I7	R2400	H9	R3472	M10	R7509	E4	V	X1002	E4	X4003	D5	Z6300	T4	
B7500	E3	C2011	T7	C2084	E10	C2249	J10	C2314	I8	C2801	H3	C2813	J6	C3301	J6	C3406	D2	C7503	G3	C7516	F8	C7543	F4	C7566	F8	F	L2080	J10	L3300	T4	L3411	C3	L3427	C8	L7504	F9	L7522	F8	N7510	F7	R2011	V8	R2502	G11	R3473	M10	R7538	G8	V2300	I8	X1003	P8	X4004	C3	Z7513	F5	
C	C2012	I7	C2108	P3	C2266	H9	C2315	H8	C2802	I3	C2814	J3	C3303	I7	C3410	D2	C7504	G3	C7520	F9	C7545	F4	C7567	G4	F2050	V9	L2104	P4	L3400	D11	L3412	D2	L3428	D4	L7505	G4	L7524	F4	N7512	F3	R2018	S6	R2503	J11	R3474	M10	R7539	G4	V2310	J10	X1400	R6	X4006	D3	Z7518	E4	
C1483	Q7	C2013	H7	C2115	E11	C2267	I10	C2316	H10	C2803	J5	C2821	J5	C3304	H7	C3412	D2	C7505	G3	C7521	F9	C7546	E4	C7570	G4	F3300	T5	L2105	P4	L3401	D11	L3413	C2	L3429	C4	L7506	G9	L7525	E4	R	R2050	V9	R2504	I1	R3475	M11	R7540	F6	V2505	J8	X3100	V7	X6100	V3			
C1484	Q7	C2015	I7	C2201	I10	C2268	H10	C2804	J3	C2822	H4	C3306	J7	C3414	E2	C7506	E3	C7523	G9	C7547	G3	C7571	G4	G	G2200	L9	L2111	R8	L3403	D10	L3414	D2	L3430	D4	L7507	E4	L7526	E9	R2000	I10	R2070	H3	R2505	J7	R3476	L11	R7541	G5	V3300	J6	X3200	O10	Z	Z2000	S7		
C1485	Q7	C2016	I7	C2213	H8	C2269	H10	C2326	H9	C2805	J4	C2823	I3	C3307	I6	C3421	D2	C7507	E9	C7524	G9	C7548	F4	C7575	F4	G2200	L9	L2111	R8	L3403	D10	L3415	C2	L3431	C4	L7508	F4	L7527	E9	R2001	I8	R2108	R7	R2507	G11	R4004	D5	R7542	G5	V3310	I7	X3201	M6	Z2000	S7		
C1486	S6	C2019	S6	C2214	I9	C2271	I9	C2329	J10	C2806	J6	C2824	J4	C3308	S5	C4002	E6	C7508	F9	C7528	G10	C7549	F4	C7579	F10	L	L2300	J9	L3404	C9	L3420	D11	L3432	D2	L7509	G8	M	R2002	I8	R2109	R8	R3200	M9	R6300	Q3	R7544	G5	V3455	M10	X3202	V8	Z3300	T5				
C1487	S6	C2050	V10	C2222	H10	C2280	I9	C2400	P8	C2807	H6	C2825	H3	C3309	S5	C4004	D6	C7509	E4	C7529	G10	C7553	F8	C7581	E3	L2010	T6	L2310	H8	L3405	C9	L3421	D11	L3433	C2	L7510	F5	M3100	R3	R2003	I8	R2115	F11	R3300	S5	R6301	Q4	R7545	F6	V3456	M10	X3203	D8	Z3301	T5		
C2001	I10	C2051	V10	C2228	H10	C2281	J9	C2401	P8	C2808	J6	C2826	H4	C3310	I6	C4005	D6	C7510	E4	C7531	G8	C7559	F8	C7583	E9	L2011	S7	L2340	J9	L3406	C8	L3422	D10	L3434	D1	L7511	F4	N	R2004	I8	R2116	F11	R3302	J7	R6302	Q5	R7546	F6	V3457	M11	X3204	V4	Z3400	E2			

www.s-manuals.com