

Service schematics

# Nokia Lumia 620

RM-846

25.01.2013

v1.0



## IMPORTANT

This document is intended for use by authorized Nokia service centers only. Please use the document together with other documents such as the Service Manual and Service Bulletins.

## Version information

While every effort has been made to ensure that the document is accurate, some errors may exist. Please always check for the latest published version for this document.

If you find any errors in the document please send email to: [service.manuals@nokia.com](mailto:service.manuals@nokia.com)

1.0 First approved version.

## Contents

- 1 Front page
- 2 PM8038, Power, UI keys, Vibra
- 3 PM8038, MSM8227, Memory, Display, Touch
- 4 MSM8227, Camera, Sensors, Top PWB flex connector, NFC, SIM
- 5 MSM8227, Audio
- 6 Bluetooth, WLAN
- 7 RF Transceiver
- 8 Component finder top
- 9 Component finder bottom

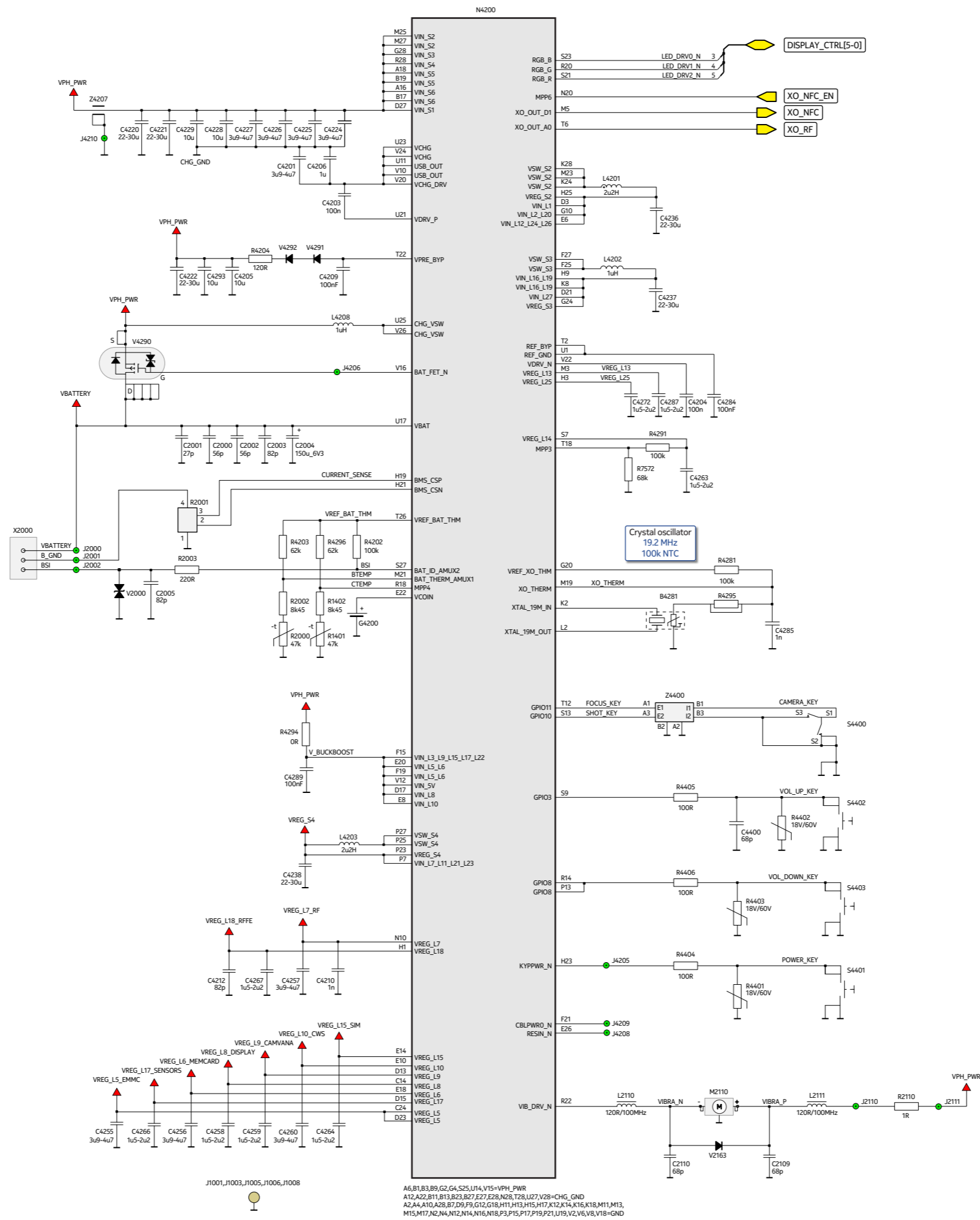

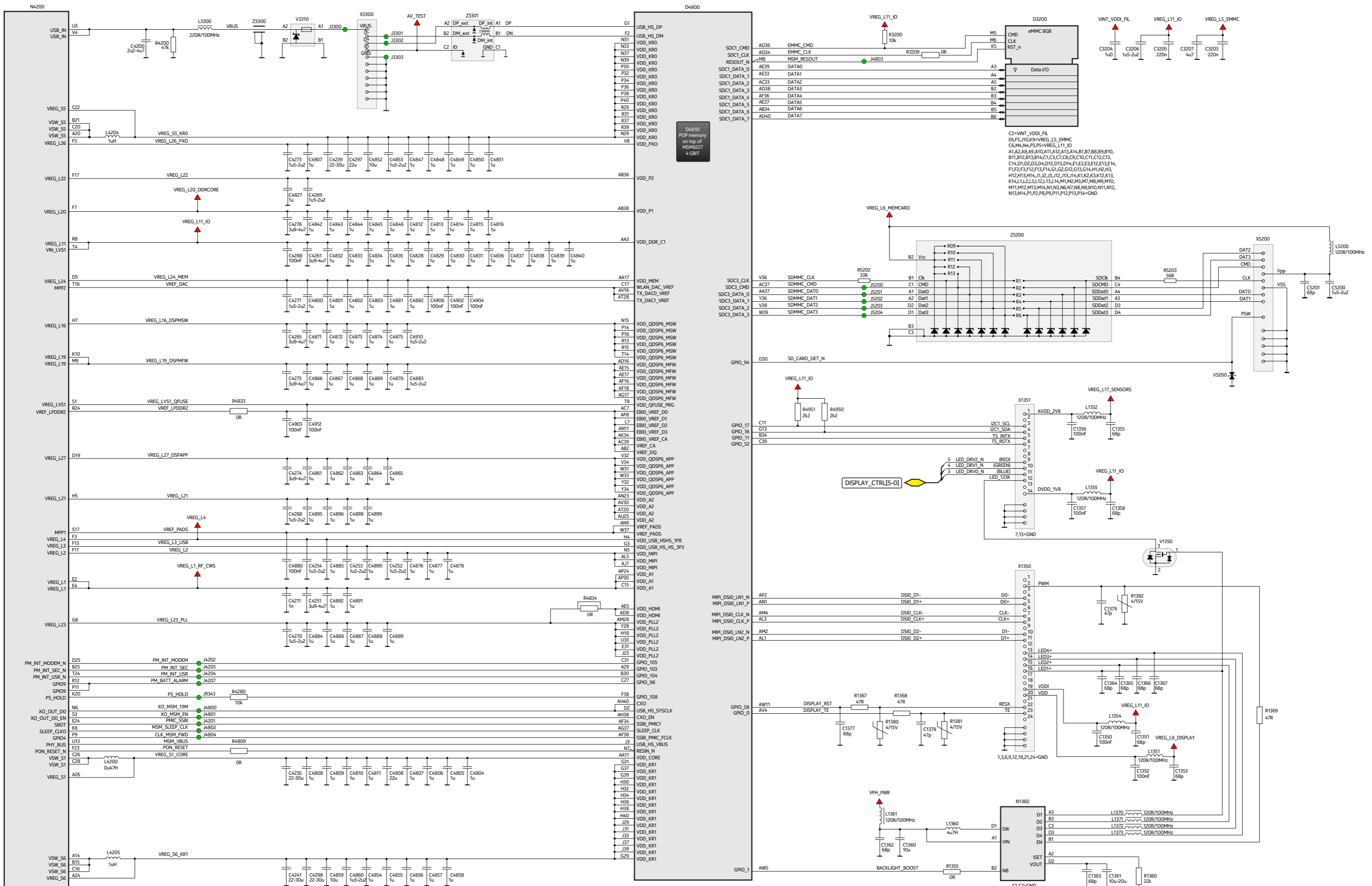

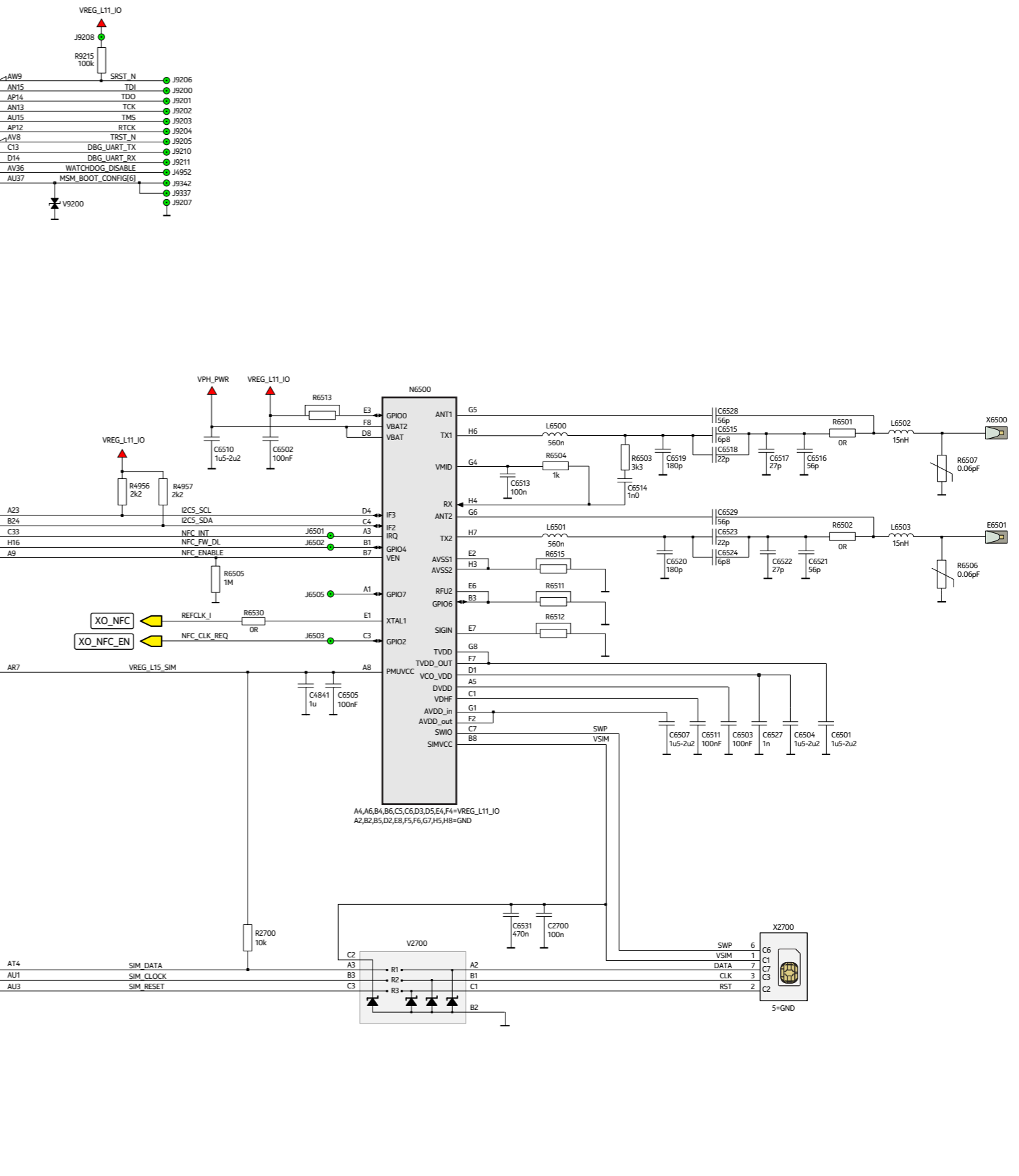
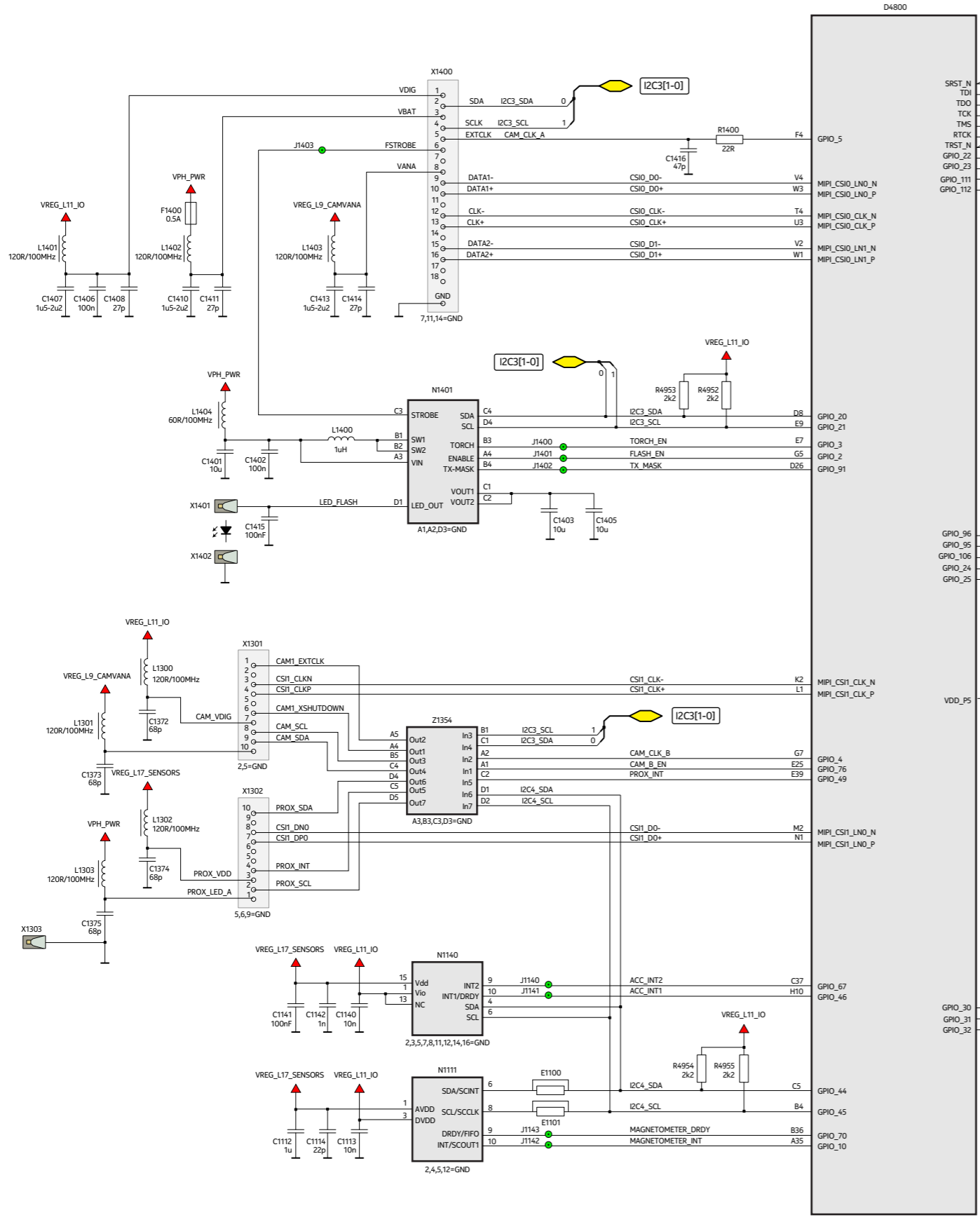

AA7,AK36,AT8,AT10,AV2,AV32,AW39,AY20,C3,E21,E29,E35,G9,G15,U37,Y40=VREG\_L11\_IO  
 AC1,AC3,AH2,AH36,AP40,AR3,AU39,AV14,AV20,AW3,AY6,B2,E3,L3,Y38=VREG\_L20\_DORCORE  
 AA31,AB16,AB30,AC15,AC17,AC27,AC31,AD10,AD12,AE11,AF12,AF26,AF30,AG11,AG25,AG27,AG29,AH26,AH28,AH30,AJ11,AJ21,AJ21,AK1,AK2,AK22,AK32,AL11,AL21,AL31,AM10,AM12,AM32,F34,H26,H28,J11,J27,K10,K12,K18,L11,M18,M20,N17,N25,P18,P26,R24,T26,T30,T32,U15,U25,U31,V14,W15,W16,W17,W25,Y26,Y16=VREG\_L24\_MEM  
 AA19,AA33,AB18,AB20,AB22,AC19,AC27,AC33,AD22,AD28,AE13,AE27,AF14,AF28,AG13,AH12,AH24,AJ13,AJ17,AJ23,AJ25,AJ27,AJ29,AK14,AK16,AK18,AK24,AK26,AK28,AL13,G23,G25,G27,G33,H24,J5,J25,K16,L15,L17,M16,MH6,N11,N33,N27,P10,P12,P22,P24,P28,R11,R21,R23,R27,R33,T22,T28,U21,U23,U27,U29,W11,W22,W3,W24,Y10,Y12,Y18=VREG\_S1\_CORE  
 AT1,A3,A7,A13,A15,A25,A31,A39,AA11,AA9,AA13,AA15,AA23,AA25,AA27,AA29,AA39,AA10,AB12,AB14,AB24,AB26,AB28,AB32,AB40,AC3,AC11,AC13,AC25,AC29,AD14,AD16,AD20,AD24,AD26,AD30,AD32,AE7,AE9,AE19,AE23,AE25,AE31,AF10,AF20,AF22,AF24,AF32,AF40,AG5,AG7,AG9,AG15,AG19,AG21,  
 AG23,AG31,AG39,AH4,AH8,AH10,AH14,AH16,AH18,AH20,AH22,AH32,AJ11,AJ15,AJ19,AJ31,AK2,AK8,AK10,AK30,AL7,AL9,AL15,AL17,AL19,AL23,AL25,AL27,AL29,AM14,AM16,AM18,AM20,AM22,AM24,AM26,AM30,AM40,AN5,AN7,AN7,AN9,AP16,AP20,AR1,AT2,AT22,AT24,AT26,AT30,AW1,AW7,  
 AW15,AW21,AW25,AW27,AV28,AW29,AV34,AW35,AV40,AY2,AY8,AY14,AY22,AY26,AY28,AY34,AY38,AY40,BB,B14,B20,B26,B32,B40,C1,D32,E33,H2,H20,J1,J9,J13,J15,J17,J19,J21,K14,K20,K22,K24,K26,K28,K30,K32,K32,K34,K36,K38,K40,L5,L9,L13,L19,L21,L23,L25,L27,L29,L31,L33,L37,L39,M10,M14,M22,M24,  
 M26,M28,M30,M32,M34,M36,M38,M40,N9,N13,N19,N21,P2,P20,R1,R5,R7,R9,R17,R19,T10,T12,T16,T18,T20,T34,T36,T45,U5,U9,U11,U13,U17,U19,V10,V12,V13,V18,V19,V20,W21,W22,V28,W29,W30,W5,W9,Y2,Y4,Y8,Y14,Y20,Y22,Y24,Y26,Y30=VREG\_L11\_IO

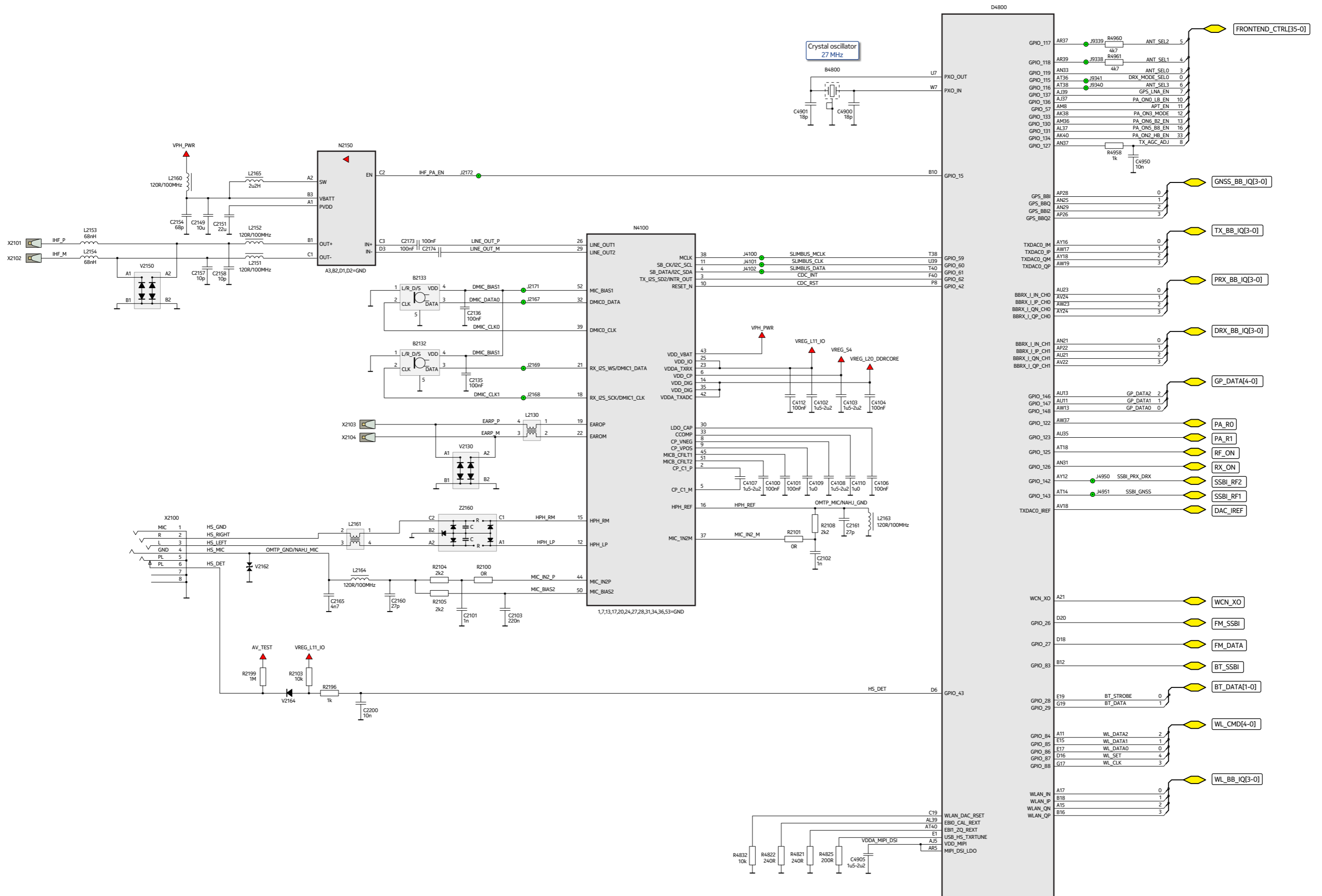

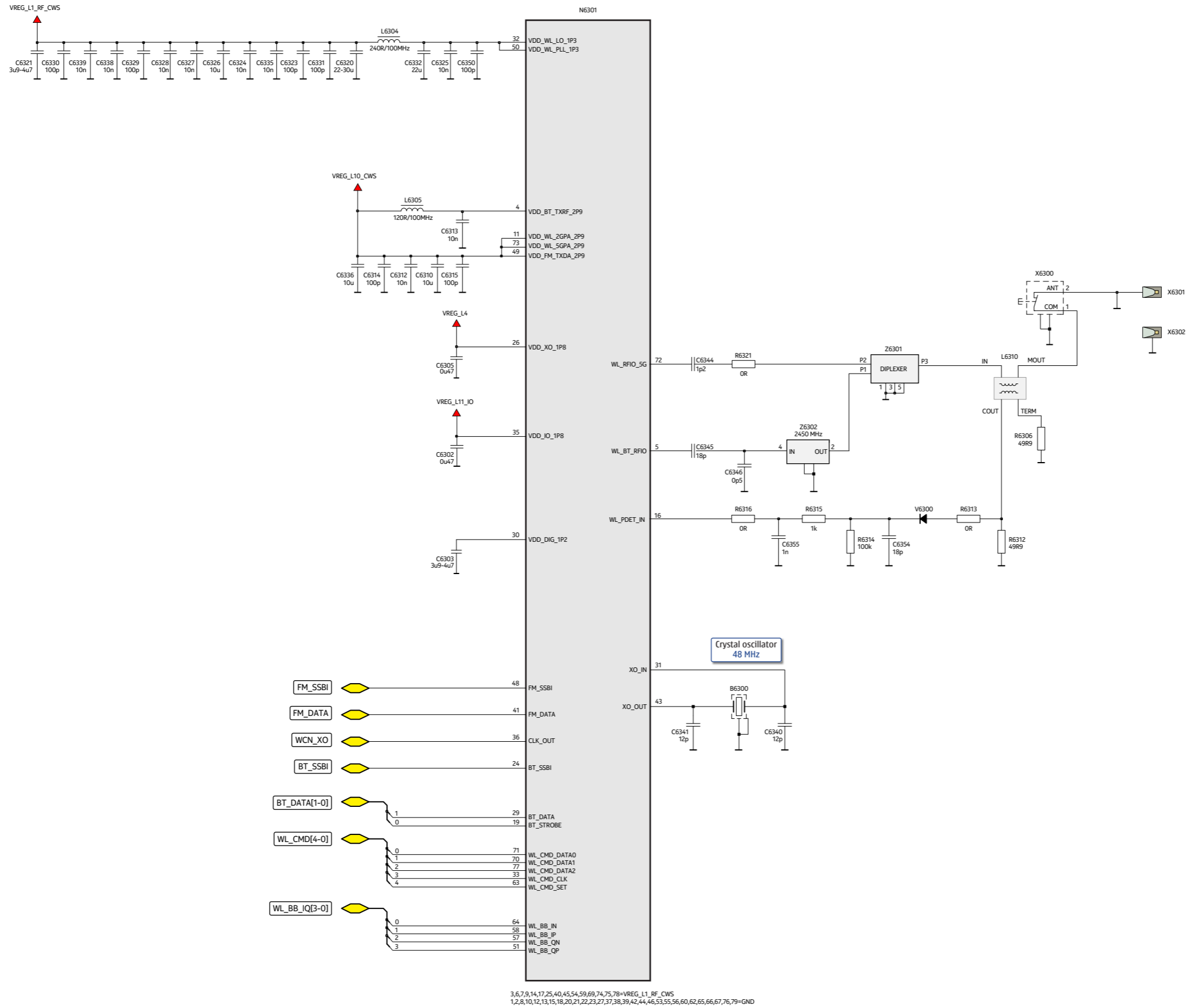

3,6,7,9,14,17,25,40,45,54,59,69,74,75,79=VREG\_L1\_RF\_CWS  
 1,2,8,10,12,13,15,18,20,21,22,23,27,37,38,39,42,44,46,53,55,56,60,62,65,66,67,76,79=GND

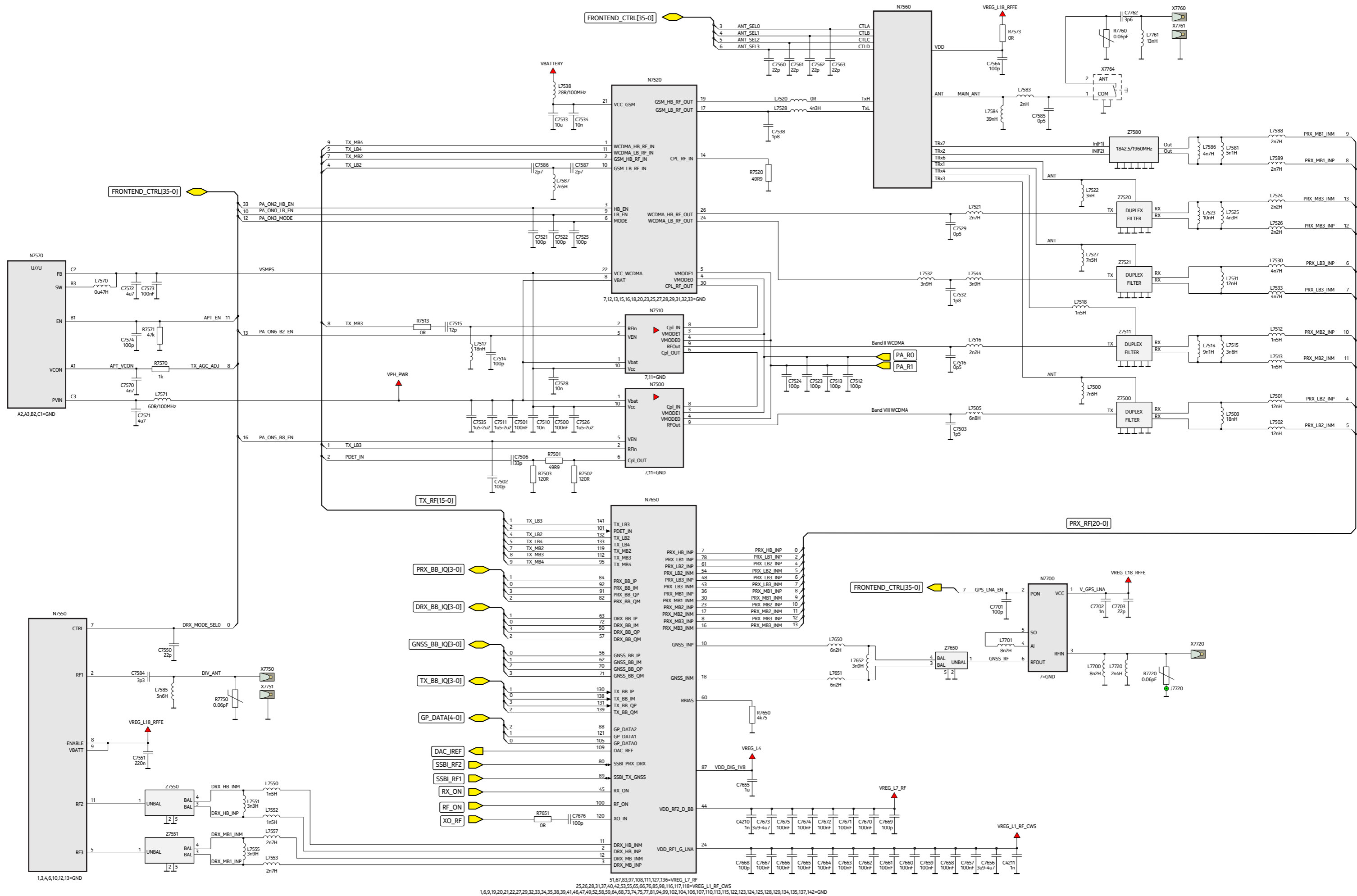

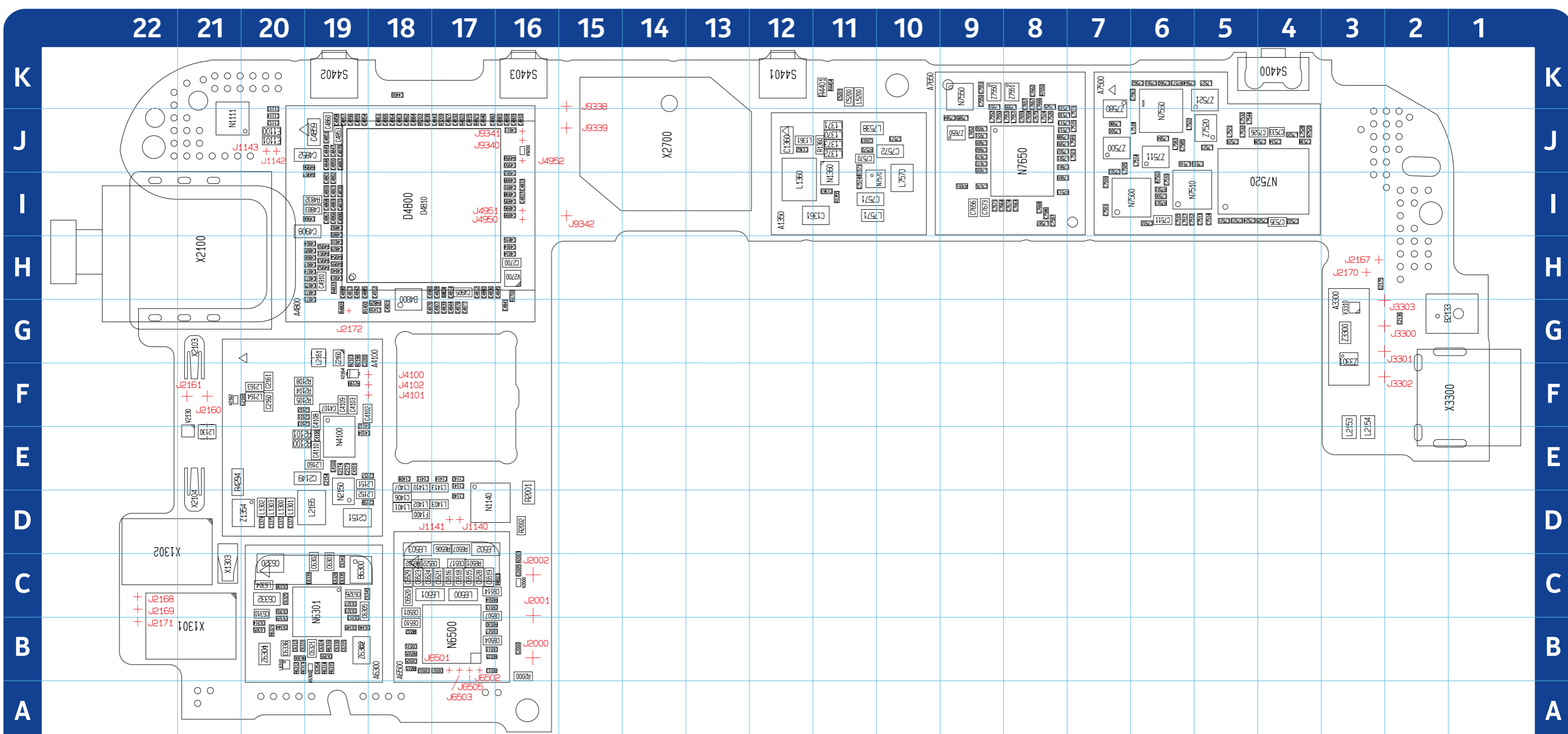

B	C1406	D18	C2158	D19	C4112	F19	C4827	z	C4846	J17	C4865	J18	C4885	H19	C4907	G17	C6325	C20	C6355	B19	C6523	C18	C7522	I4	C7570	J11	C7665	J9	F1400	D18	L2154	E3	L7512	J8	L7533	K8	L7650	J9	R1355	I11	R4404	K11	R6312	B20	R7502	I6	V2700	H16	Z6301	B20	J2161	F21	J6503	B17	
B2133	G1	C1407	E18	C2160	F20	C4400	K18	C4828	H17	C4847	J19	C4866	I19	C4886	I19	C4908	I19	C6326	C19	C6501	C18	C6524	C18	C7523	I5	C7571	I11	C7666	K8	L	L2160	E19	L7513	J8	L7538	J11	L7651	J9	R1360	J11	R4809	G19	R6313	B20	R7503	I6	V3310	G3	Z6302	B19	J2167	H3	J6505	B17	
B4800	H18	C1408	E18	C2161	F20	C4800	I19	C4829	H19	C4848	J19	C4867	I19	C4887	J19	C4910	H19	C6327	C19	C6502	B18	C6527	B17	C7524	I5	C7572	J10	C7667	K8	L1300	D20	L2161	G19	L7514	J6	L7544	J5	L7652	J9	R1400	G19	R4821	J17	R6314	B19	R7513	I8	V6300	B19	Z7500	J7	J2168	C22	J9338	K15
B6300	C19	C1410	E18	C2165	F20	C4801	I19	C4830	I19	C4849	J19	C4868	I19	C4888	I16	C4912	H18	C6328	C19	C6503	B17	C6528	C17	C7525	I4	C7573	J10	C7668	I8	L1301	D20	L2163	F20	L7515	J7	L7550	J9	N	R2000	B16	R4822	J17	R6315	B19	R7520	J4	V9200	J16	Z7511	J6	J2169	C22	J9339	J15	
C	C1411	E18	C2173	E19	C4802	I19	C4831	H19	C4850	J19	C4869	I19	C4889	I19	C4950	J16	C6329	B20	C6504	B17	C6529	C18	C7526	J4	C7574	I11	C7669	I8	L1302	D20	L2164	F20	L7516	J6	L7551	K9	N1111	J21	R2001	D16	R4825	G18	R6316	B19	R7570	J11	X	Z7520	J5	J2170	H3	J9340	J16		
C1112	J20	C1413	E17	C2174	E19	C4803	I19	C4832	J17	C4851	J19	C4870	I19	C4890	H19	C5200	K11	C6330	B19	C6505	B18	C6531	B18	C7528	J4	C7584	J9	C7670	J9	L1303	D20	L2165	D19	L7517	I6	L7552	J9	N1140	D17	R2002	D16	R4832	I19	R6321	B20	R7571	J11	X1301	B21	Z7521	K5	J2171	B22	J9341	J16
C1113	J20	C1414	E17	C2175	H3	C4804	H19	C4833	I16	C4852	J19	C4871	G19	C4891	I16	C5201	K11	C6331	B20	C6507	C17	C7500	I7	C7529	J5	C7585	J6	C7671	I9	L1360	I12	L5200	K11	L7518	J6	L7553	J8	N1360	I11	R2003	C16	R4833	H19	R6501	C17	R7573	K6	X1302	D22	Z7550	K9	J2172	G19	J9342	I15
C1114	J20	C1416	G18	C2200	G19	C4805	H19	C4834	H16	C4853	J19	C4872	H19	C4892	I19	C6302	C19	C6332	C20	C6510	B18	C7501	I7	C7532	J5	C7586	I8	C7672	J9	L1361	J12	L6304	C20	L7520	J4	L7555	K8	N2150	D19	R2100	E20	R4834	H17	R6502	C18	R7650	K8	X1303	C21	Z7551	K8	J3300	G3		
C1140	D17	C2000	B16	C2700	H16	C4806	H19	C4835	J19	C4854	J19	C4873	H19	C4895	I16	C6303	C19	C6335	C19	C6511	B17	C7502	I6	C7533	J4	C7587	I8	C7673	I9	L1370	J11	L6305	B20	L7521	J5	L7557	J8	N4100	E19	R2101	E20	R4950	H19	R6503	C16	R7651	I9	X2100	H21	Z7580	J7	J3301	G3		
C1141	E17	C2003	J11	C4100	E19	C4807	H19	C4836	H17	C4855	J19	C4874	H19	C4896	I16	C6305	C19	C6336	B20	C6513	C17	C7503	J7	C7534	J4	C7655	J9	C7674	I8	L1371	J11	L6310	B20	L7522	J6	L7570	I10	N6301	C19	R2103	G19	R4951	H19	R6504	C17	S	X2103	G21	Z7650	J9	J3302	F3			
C1142	E17	C2005	C16	C4101	E19	C4808	J16	C4837	I16	C4856	J19	C4875	H19	C4898	I16	C6310	C20	C6338	B20	C6514	C17	C7506	I6	C7535	I4	C7656	I9	C7675	J8	L1372	J11	L6500	C17	L7523	J5	L7571	I11	N6500	B17	R2104	F20	R4952	H19	R6505	B18	S4400	K4	X2104	E21	TST points	J3303	G3			
C1360	J12	C2101	F20	C4102	F19	C4809	J16	C4838	J18	C4857	J19	C4876	G18	C4899	I16	C6312	B20	C6339	C19	C6515	C17	C7510	I6	C7538	J4	C7657	K8	C7676	I9	L1373	J11	L6501	C18	L7524	J8	L7581	J7	N7500	I6	R2105	F20	R4953	H19	R6506	D17	S4401	K12	X2700	J14	J1140	D17	J4100	F18		
C1361	I11	C2102	F20	C4103	F19	C4810	J16	C4839	G17	C4858	J19	C4877	G17	C4900	H18	C6313	B19	C6340	C19	C6516	C17	C7511	I6	C7550	K9	C7658	J8	D	L1401	D18	L6502	D17	L7525	K8	L7583	J6	N7510	I6	R2108	F20	R4954	H19	R6507	D17	S4402	K19	X3300	F1	J1141	D17	J4101	F18			
C1362	J12	C2103	F20	C4104	E19	C4811	J16	C4840	H19	C4859	J19	C4878	G17	C4901	G18	C6314	B20	C6341	C19	C6517	C17	C7512	I6	C7551	K9	C7659	J8	D4800	I18	L1402	D18	L6503	D18	L7526	J8	L7584	J6	N7520	I4	R2196	G19	R4955	H19	R6511	B18	S4403	K16	Z	J1142	J20	J4102	F18			
C1363	I11	C2136	G2	C4106	E19	C4812	H17	C4841	G16	C4860	J19	C4880	H17	C4902	I16	C6315	B19	C6344	B20	C6518	C17	C7513	I5	C7560	K6	C7660	J9	D4810	I18	L1403	D17	L7500	J7	L7527	K5	L7585	J9	N7550	K9	R2199	F19	R4956	J19	R6512	B18	V	Z1354	D20	J1143	J20	J4950	I16			
C1372	D20	C2149	E19	C4107	F19	C4813	H19	C4842	H19	C4861	J18	C4881	J16	C4903	H19	C6320	C20	C6345	B19	C6519	C17	C7514	I5	C7561	K6	C7661	J8	E	L2130	E21	L7501	J8	L7528	J4	L7586	J7	N7560	J6	R2700	H16	R4957	I9	R6513	B17	V2000	C16	Z2160	G19	J2000	B16	J4951	I16			
C1373	D20	C2151	D19	C4108	F19	C4814	H17	C4843	J17	C4862	J18	C4882	J17	C4904	H16	C6321	B19	C6346	B19	C6520	C18	C7515	I6	C7562	K6	C7662	K8	E1100	J20	L2151	E19	L7502	J8	L7530	J8	L7587	I8	N7570	I11	R3209	J17	R4958	J16	R6515	B17	V2130	E21	Z2184	F21	J2001	C16	J4952	J16		
C1374	D20	C2154	E19	C4109	F19	C4815	J17	C4844	G17	C4863	J18	C4883	J19	C4905	H17	C6323	C19	C6350	C20	C6521	C17	C7516	J5	C7563	K6	C7663	I8	E1101	J20	L2152	D19	L7503	J7	L7531	J7	L7588	J8	N7650	J8	R4294	E21	R5202	J18	R6530	B17	V2162	F21	Z3300	G3	J2002	C16	J6501	B17		
C1375	D20	C2157	E19	C4110	E19	C4816	H16	C4845	H16	C4864	J18	C4884	J18	C4906	I19	C6324	B19	C6354	B19	C6522	C18	C7521	I5	C7564	K6	C7664	I9	F	L2153	E3	L7505	J7	L7532	J5	L7589	J8	R	R4401	K11	R6306	B20	R7501	I6	V2164	F19	Z3301	G3	J2160	F21	J6502	B17				



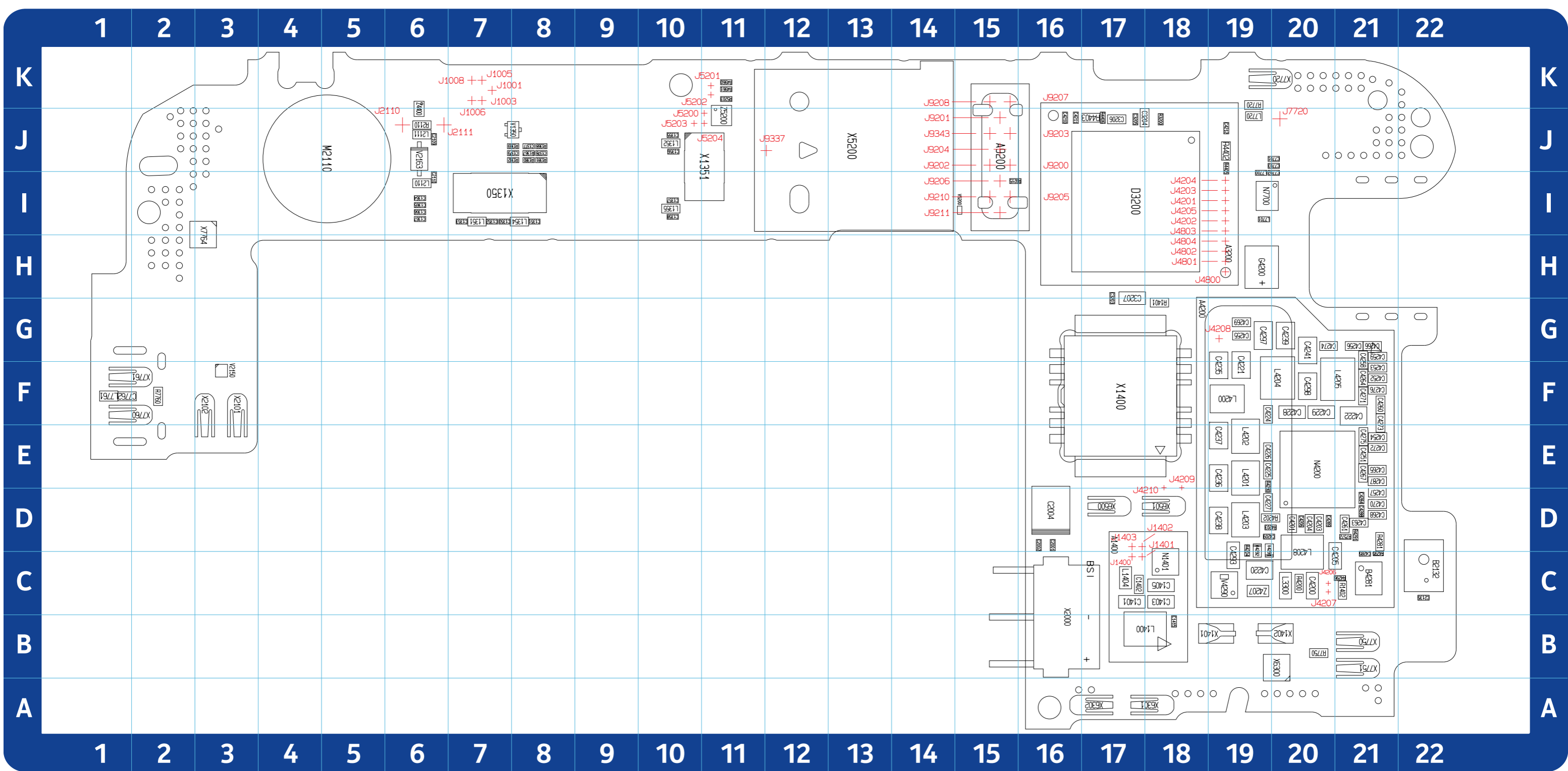

B	C1402	C17	C4206	D20	C4251	E21	C4272	E21	G4200	H19	L7720	J19	R4202	D19	V	X6302	A17	Z6303	A18	J4208	G19	J9206	I15		
B2132	C22	C1403	C18	C4209	D19	C4252	F21	C4273	F21	L	L7761	F1	R4203	D19	V1350	J8	X6500	D17	TST points	J4209	E18	J9207	K15		
B4281	C21	C1405	C18	C4210	J16	C4253	F21	C4274	G20	L1351	I7	M	R4204	D19	V2150	F3	X6501	D18	J1001	K7	J4210	E18	J9208	K15	
C	C1415	B18	C4211	J16	C4254	E21	C4275	E21	L1352	J10	M2110	J5	R4280	E19	V2163	J6	X7720	K19	J1003	K7	J4800	H19	J9210	I15	
C1350	I7	C2001	D16	C4212	J19	C4255	G19	C4276	F21	L1354	I8	N	R4281	D21	V4290	C19	X7750	B21	J1005	K7	J4801	H19	J9211	I15	
C1351	I8	C2002	D16	C4220	C19	C4256	G21	C4284	D21	L1355	I10	N1401	C18	R4291	D21	V4291	D19	X7751	B21	J1006	K7	J4802	H19	J9337	J12
C1352	I7	C2004	D16	C4221	F19	C4257	D21	C4285	C21	L1400	B18	N4200	E20	R4295	C21	V4292	D19	X7760	F1	J1008	K7	J4803	I19	J9343	J15
C1353	I7	C2109	J6	C4222	F21	C4258	G21	C4287	E21	L1404	C17	N7700	I19	R4296	C21	V5200	I15	X7761	F1	J1400	C17	J4804	H19		
C1355	J10	C2110	I6	C4224	F19	C4259	G21	C4288	D21	L2110	I6	R	R4402	J19	X	X7764	I3	J1401	C17	J5200	J11				
C1356	J10	C2135	C22	C4225	E19	C4260	F21	C4289	D20	L2111	J6	R1367	J8	R4403	J17	X1350	I7	Z	J1402	D17	J5201	K11			
C1357	I10	C3203	H17	C4226	E19	C4261	D21	C4293	C19	L3300	C20	R1368	J8	R4405	J19	X1351	J11	Z4200	F19	J1403	D17	J5202	K11		
C1358	I10	C3204	J17	C4227	D19	C4263	D21	C4297	G19	L4200	F19	R1369	J8	R4406	J17	X1400	F17	Z4201	E19	J2110	J6	J5203	J10		
C1364	I6	C3205	J17	C4228	F20	C4264	F21	C4298	F20	L4201	E19	R1380	J8	R4960	K11	X1401	B19	Z4202	E19	J2111	J6	J5204	J11		
C1365	I6	C3206	J17	C4229	F20	C4265	E21	C7701	J20	L4202	E19	R1381	J8	R4961	K11	X1402	B20	Z4203	D19	J4201	I19	J7720	J20		
C1366	I6	C3207	H17	C4235	F19	C4266	G21	C7702	I20	L4203	D19	R1382	J8	R5203	K11	X2000	B16	Z4204	F20	J4202	I19	J9200	J15		
C1367	I6	C4200	C20	C4236	E19	C4267	E21	C7703	J20	L4204	F20	R1401	G18	R7572	D21	X2101	F3	Z4205	F20	J4203	I19	J9201	J15		
C1377	J8	C4201	D20	C4237	E19	C4268	D21	C7762	F1	L4205	F21	R1402	C21	R7720	K19	X2102	F3	Z4206	C20	J4204	I19	J9202	J15		
C1378	J8	C4203	D20	C4238	D19	C4269	G19	D	L4208	C20	R2110	J6	R7750	B20	X5200	J13	Z4207	C19	J4205	I19	J9203	J15			
C1379	J8	C4204	D20	C4239	G20	C4270	D21	D3200	I17	L7700	I19	R3200	J18	R7760	F2	X6300	B20	Z4400	J6	J4206	C20	J9204	J15		
C1401	C17	C4205	C21	C4241	G20	C4271	F21	G	L7701	I19	R4200	C20	R9215	I15	X6301	A18	Z5200	J11	J4207	C20	J9205	I15			

[www.s-manuals.com](http://www.s-manuals.com)