

Service

Schematics RM-801

Contain

1. Baseband power
2. Baseband High speed signal
3. Baseband GPIO
4. PMIC clock and GPIO
5. PMIC internal SW LDO and LDO
6. PMIC charger and battery circuit
7. External SWLDO and Gauge
8. eMMC
9. Audio Circuit
10. Camera circuit
11. Display circuit
- 12~19 RF circuit
- 20~22 BT\FM\WIFI
- 23 G-sensor and E-compass
24. SIM
25. Vibrator, Side key, audio Jack , Light & proximity and Microphone Right & Speaker
26. Top placement
27. Bottom placement
28. Top side clock signal
29. Bottom side connector location

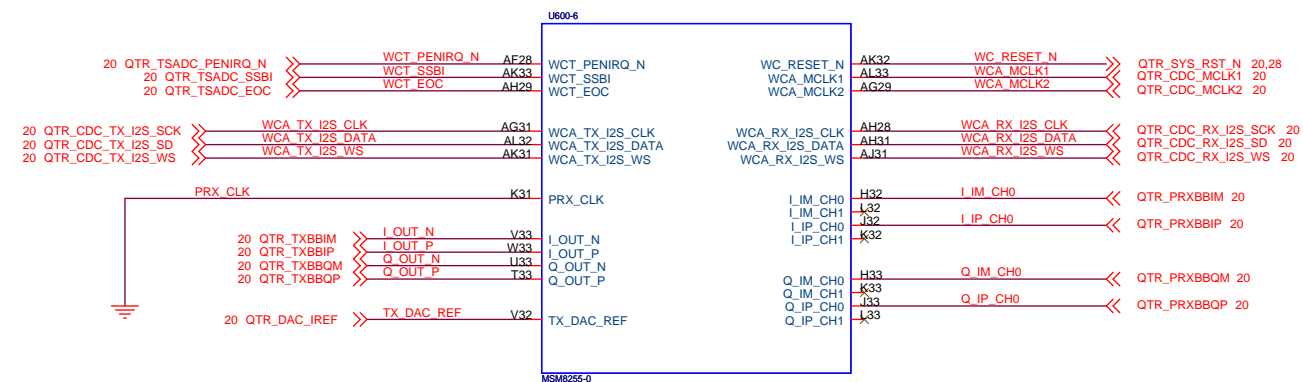
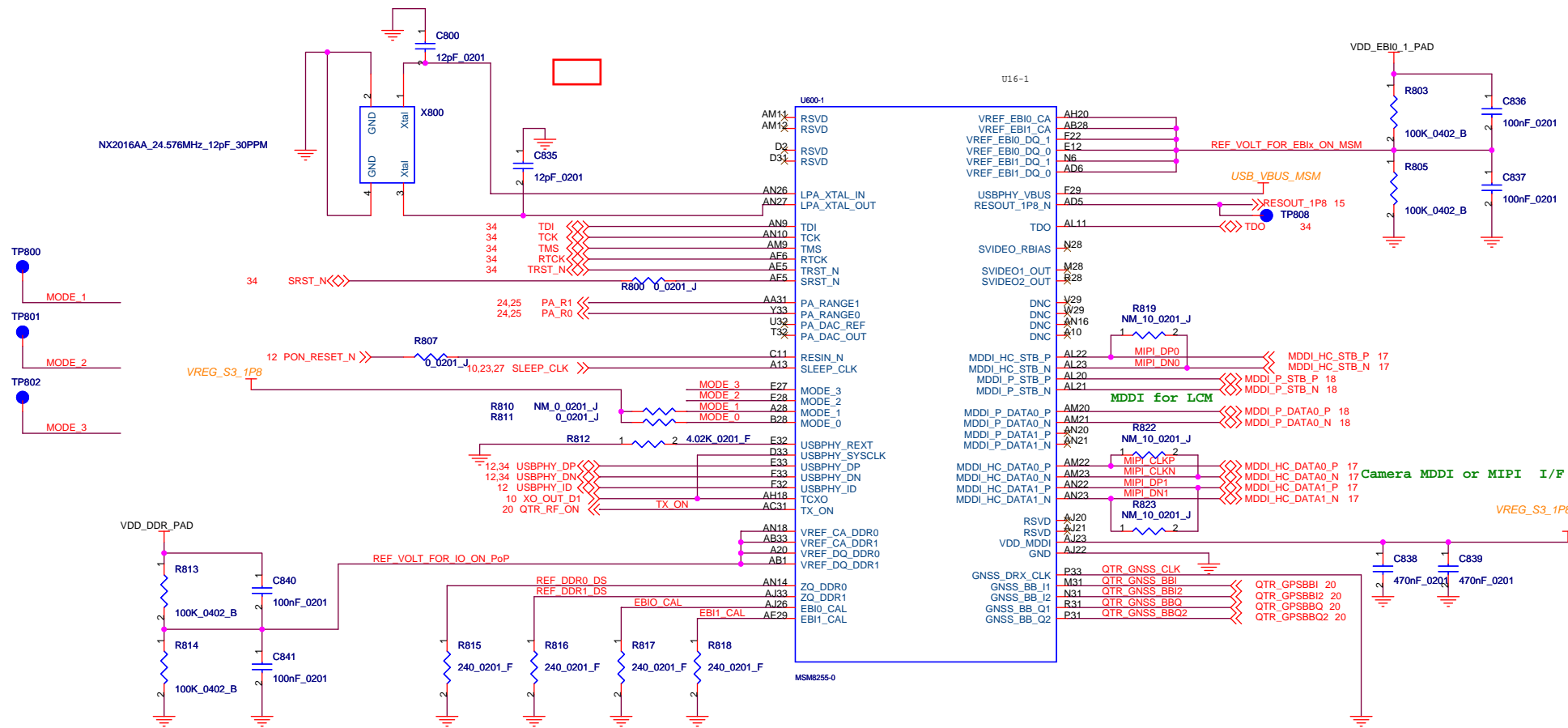

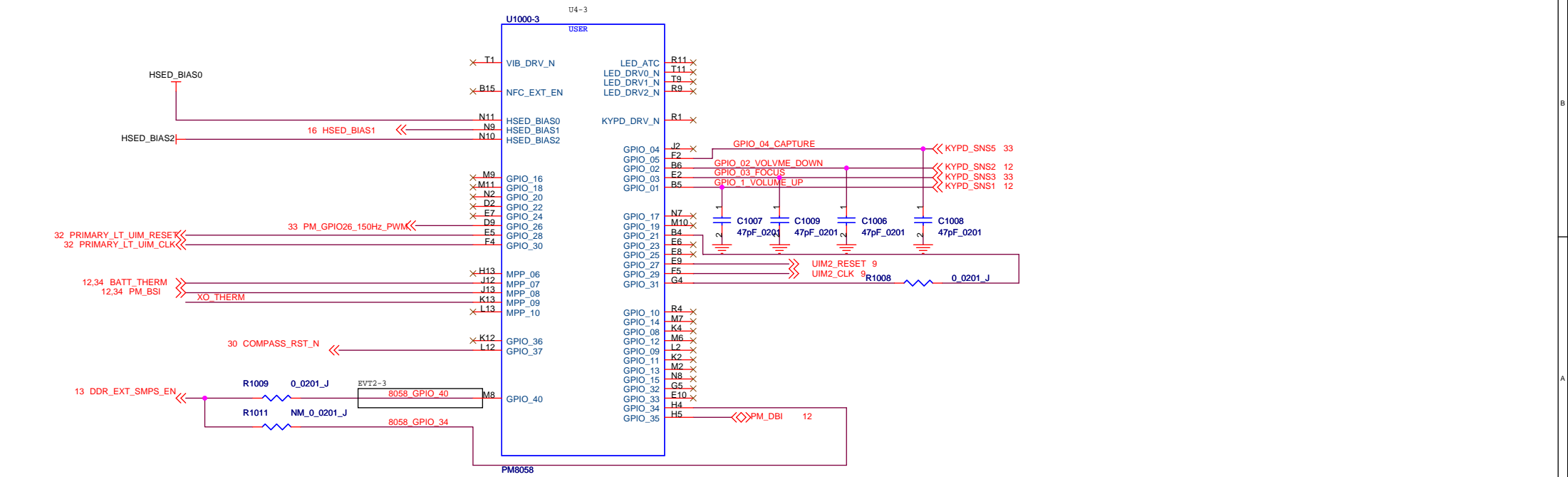
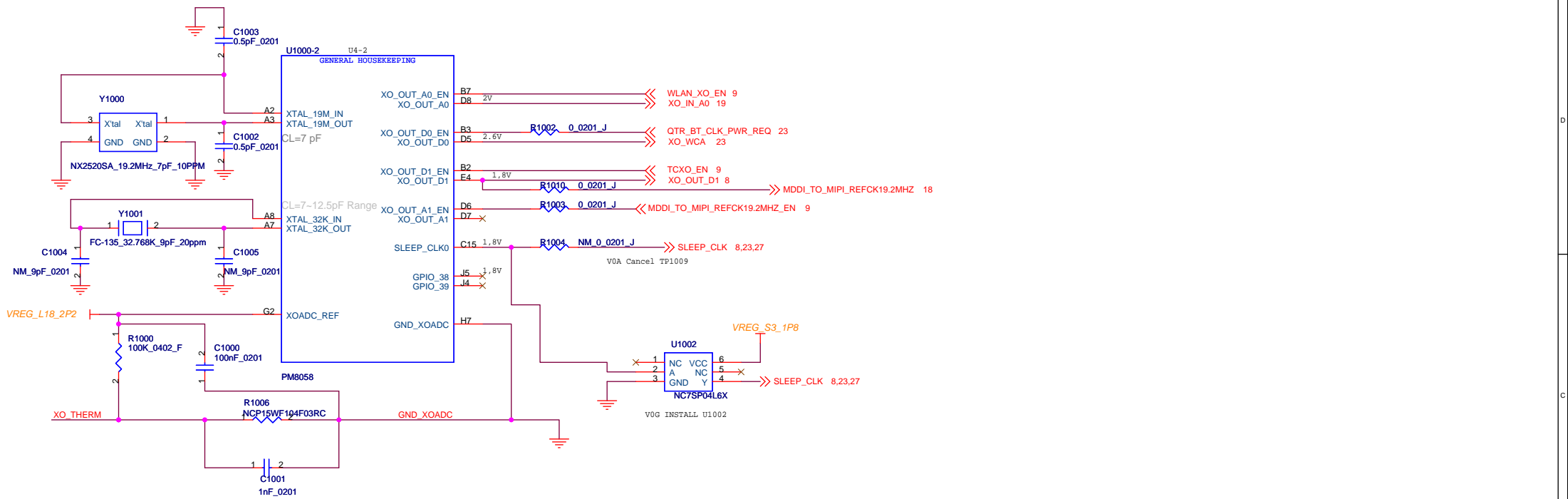

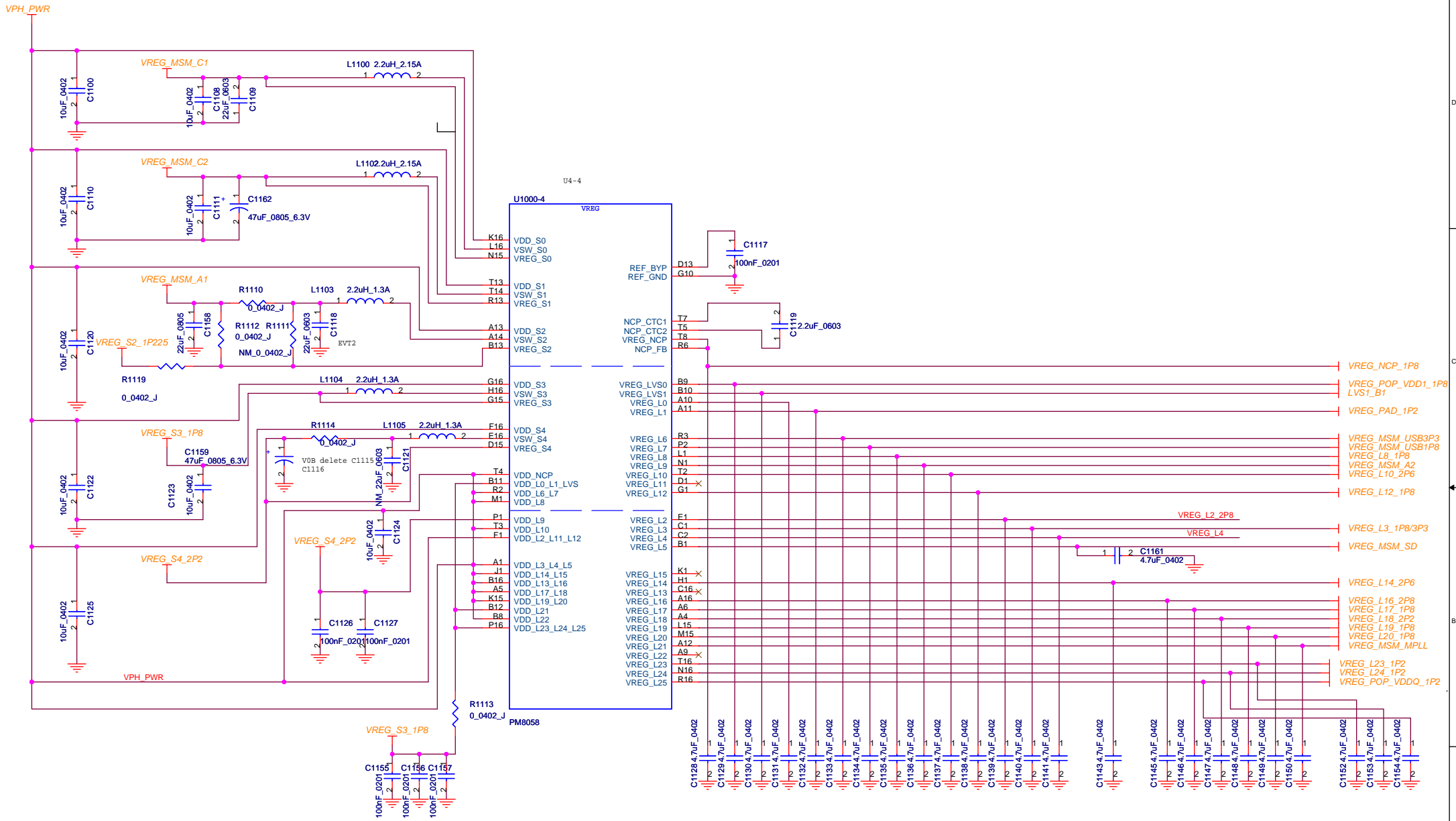

D

C

B

A

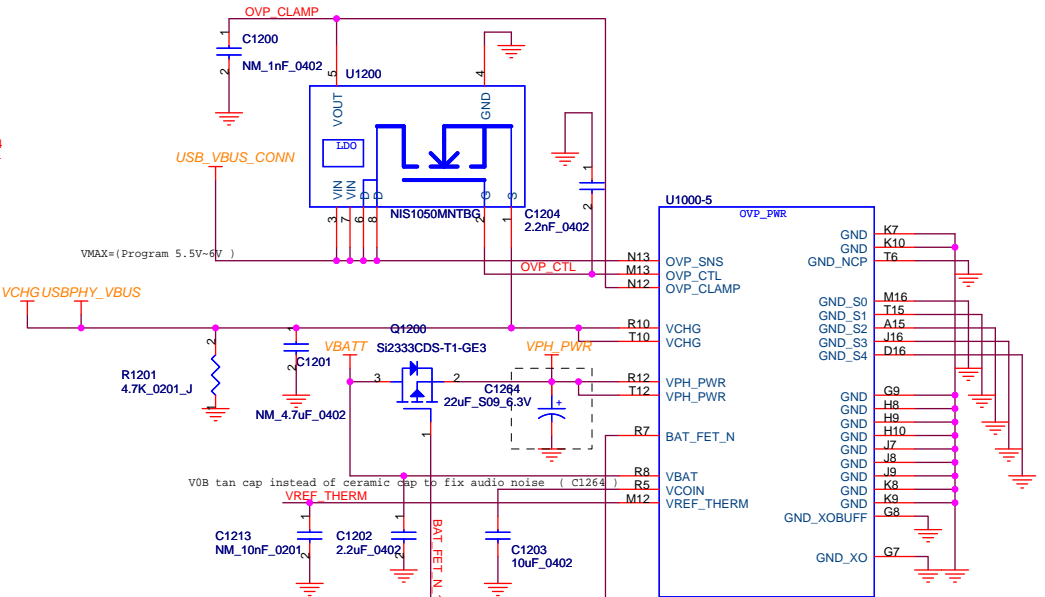
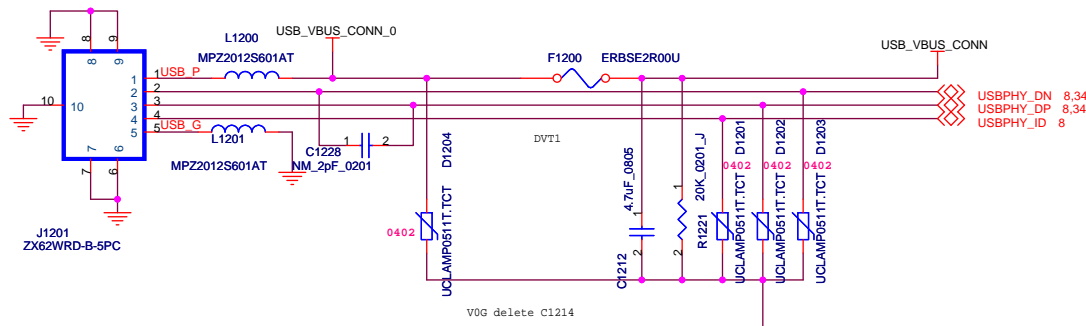

V0A Remove ST RESET IC circuit

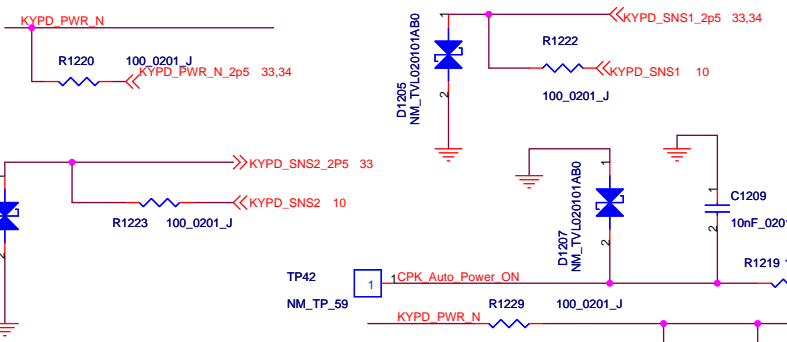

V0G Remove DBI switch

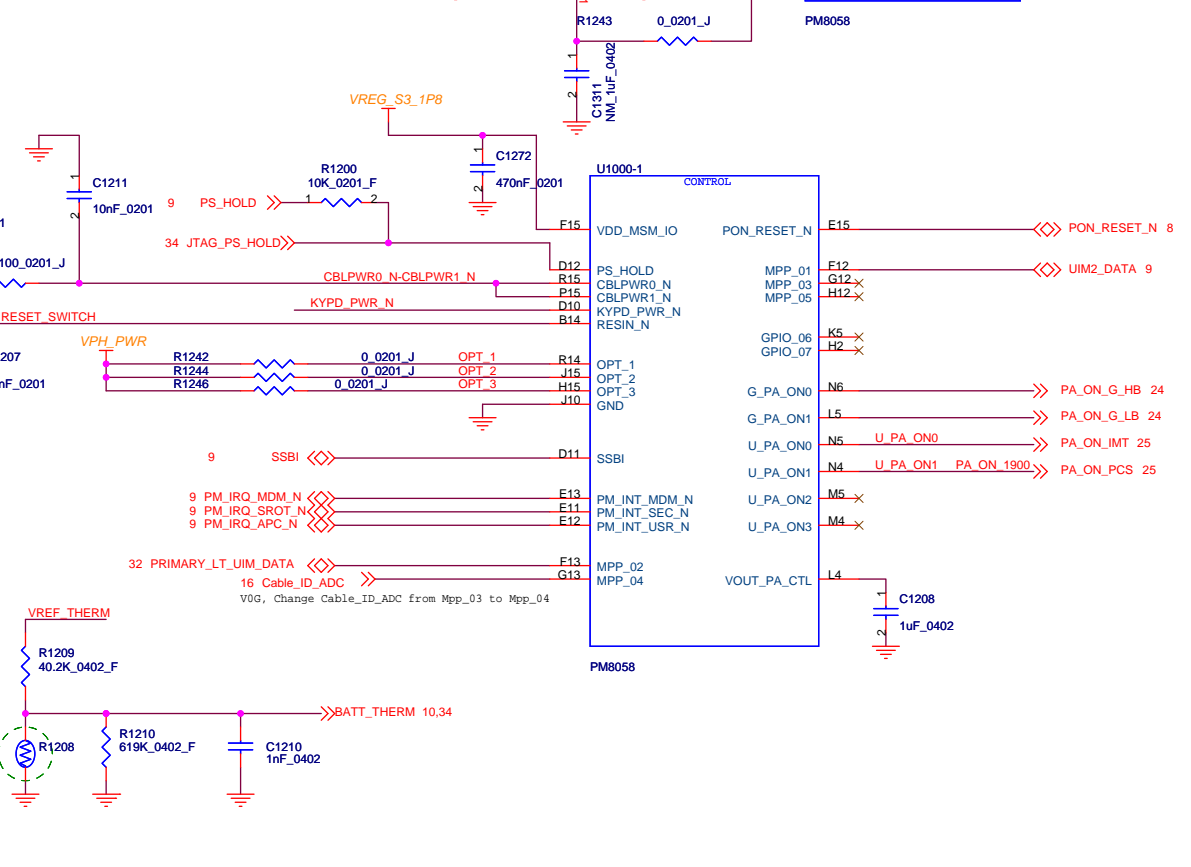
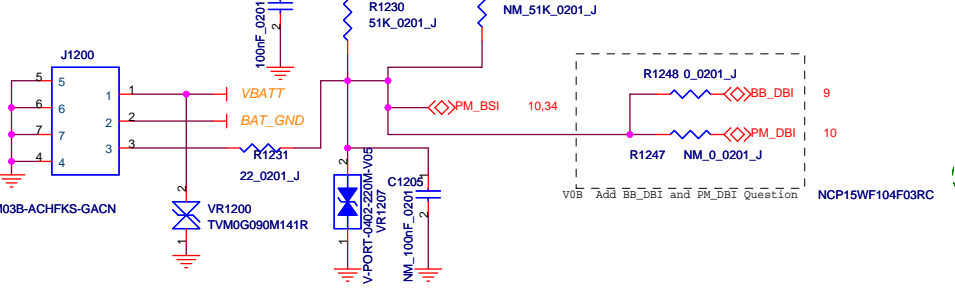

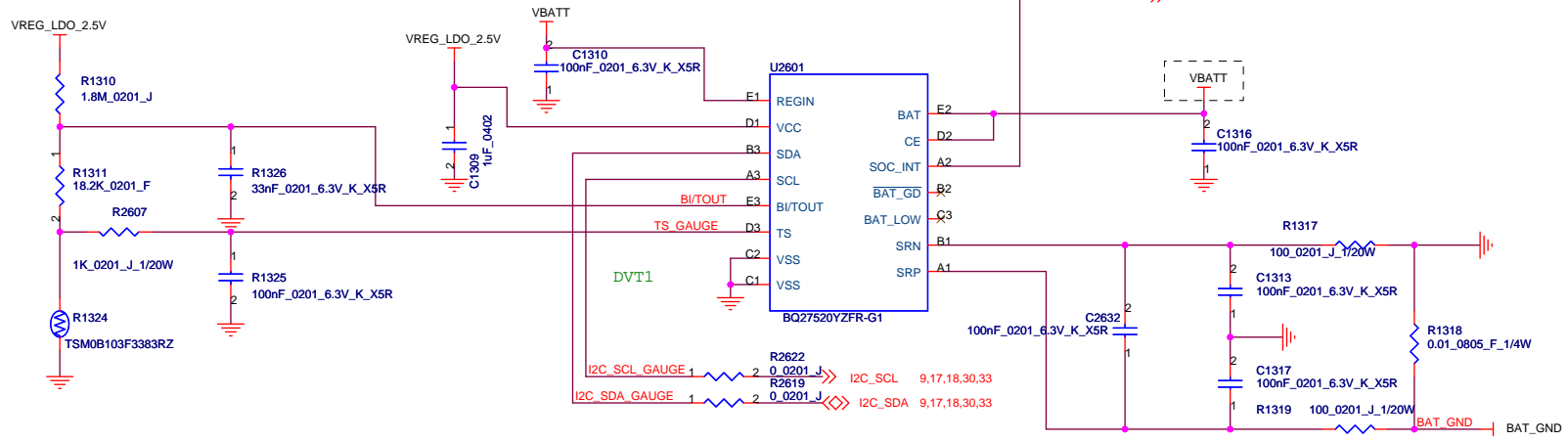
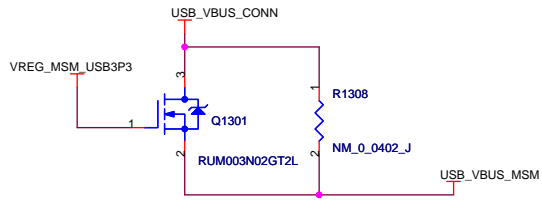
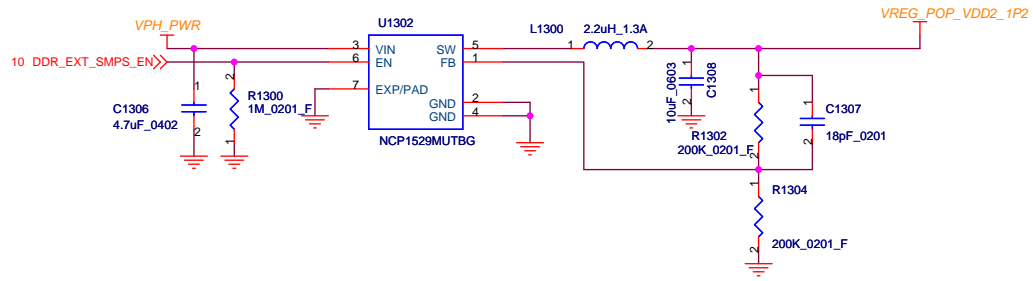

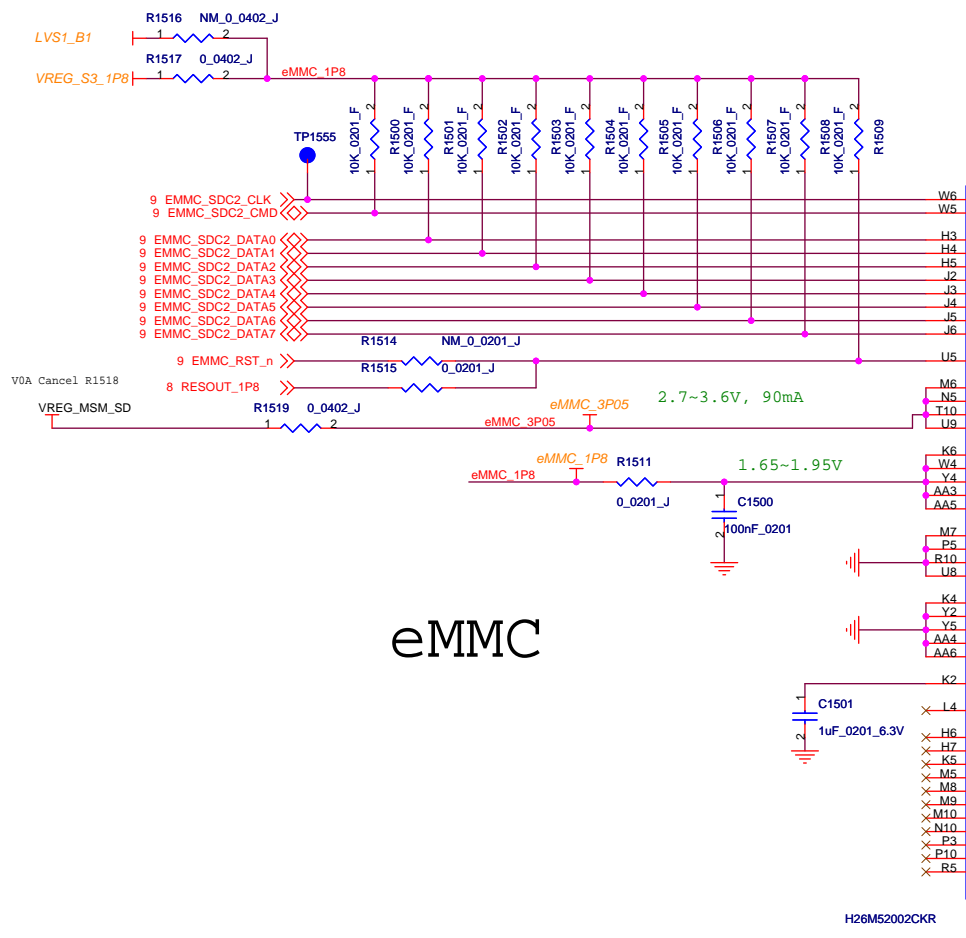

eMMC

U1500	Pin	Signal	Value
	V1	CLK	NC
	V2	CMD	NC
	V3		NC
	V12		NC
	V13		NC
	V14		NC
	W1		NC
	W2		NC
	W3		NC
	W7		NC
	W8		NC
	W9		NC
	W10		NC
	W11		NC
	W12		NC
	W13		NC
	W14		NC
	V1		NC
	V6		NC
	V7		NC
	V8		NC
	V9		NC
	V10		NC
	V11		NC
	V12		NC
	V13		NC
	V14		NC
	AA1		NC
	AA2		NC
	AA3		NC
	AA4		NC
	AA5		NC
	AA6		NC
	AA7		NC
	AA8		NC
	AA9		NC
	AA10		NC
	AA11		NC
	AA12		NC
	AA13		NC
	AA14		NC
	AE1		NC
	AE2		NC
	AE3		NC
	AE4		NC
	AG1		NC
	AG2		NC
	AG3		NC
	AG4		NC
	AG5		NC
	AG6		NC
	AG7		NC
	AG8		NC
	AG9		NC
	AG10		NC
	AG11		NC
	AG12		NC
	AG13		NC
	AG14		NC
	AG15		NC
	AG16		NC
	AG17		NC
	AG18		NC
	AG19		NC
	AG20		NC
	AG21		NC
	AG22		NC
	AG23		NC
	AG24		NC
	AG25		NC
	AG26		NC
	AG27		NC
	AG28		NC
	AG29		NC
	AG30		NC
	AG31		NC
	AG32		NC
	AG33		NC
	AG34		NC
	AG35		NC
	AG36		NC
	AG37		NC
	AG38		NC
	AG39		NC
	AG40		NC
	AG41		NC
	AG42		NC
	AG43		NC
	AG44		NC
	AG45		NC
	AG46		NC
	AG47		NC
	AG48		NC
	AG49		NC
	AG50		NC
	AG51		NC
	AG52		NC
	AG53		NC
	AG54		NC
	AG55		NC
	AG56		NC
	AG57		NC
	AG58		NC
	AG59		NC
	AG60		NC
	AG61		NC
	AG62		NC
	AG63		NC
	AG64		NC
	AG65		NC
	AG66		NC
	AG67		NC
	AG68		NC
	AG69		NC
	AG70		NC
	AG71		NC
	AG72		NC
	AG73		NC
	AG74		NC
	AG75		NC
	AG76		NC
	AG77		NC
	AG78		NC
	AG79		NC
	AG80		NC
	AG81		NC
	AG82		NC
	AG83		NC
	AG84		NC
	AG85		NC
	AG86		NC
	AG87		NC
	AG88		NC
	AG89		NC
	AG90		NC
	AG91		NC
	AG92		NC
	AG93		NC
	AG94		NC
	AG95		NC
	AG96		NC
	AG97		NC
	AG98		NC
	AG99		NC
	AG100		NC
	AG101		NC
	AG102		NC
	AG103		NC
	AG104		NC
	AG105		NC
	AG106		NC
	AG107		NC
	AG108		NC
	AG109		NC
	AG110		NC
	AG111		NC
	AG112		NC
	AG113		NC
	AG114		NC
	AG115		NC
	AG116		NC
	AG117		NC
	AG118		NC
	AG119		NC
	AG120		NC
	AG121		NC
	AG122		NC
	AG123		NC
	AG124		NC
	AG125		NC
	AG126		NC
	AG127		NC
	AG128		NC
	AG129		NC
	AG130		NC
	AG131		NC
	AG132		NC
	AG133		NC
	AG134		NC
	AG135		NC
	AG136		NC
	AG137		NC
	AG138		NC
	AG139		NC
	AG140		NC
	AG141		NC
	AG142		NC
	AG143		NC
	AG144		NC
	AG145		NC
	AG146		NC
	AG147		NC
	AG148		NC
	AG149		NC
	AG150		NC
	AG151		NC
	AG152		NC
	AG153		NC
	AG154		NC
	AG155		NC
	AG156		NC
	AG157		NC
	AG158		NC
	AG159		NC
	AG160		NC
	AG161		NC
	AG162		NC
	AG163		NC
	AG164		NC
	AG165		NC
	AG166		NC
	AG167		NC
	AG168		NC
	AG169		NC
	AG170		NC
	AG171		NC
	AG172		NC
	AG173		NC
	AG174		NC
	AG175		NC
	AG176		NC
	AG177		NC
	AG178		NC
	AG179		NC
	AG180		NC
	AG181		NC
	AG182		NC
	AG183		NC
	AG184		NC
	AG185		NC
	AG186		NC
	AG187		NC
	AG188		NC
	AG189		NC
	AG190		NC
	AG191		NC
	AG192		NC
	AG193		NC
	AG194		NC
	AG195		NC
	AG196		NC
	AG197		NC
	AG198		NC
	AG199		NC
	AG200		NC
	AG201		NC
	AG202		NC
	AG203		NC
	AG204		NC
	AG205		NC
	AG206		NC
	AG207		NC
	AG208		NC
	AG209		NC
	AG210		NC
	AG211		NC
	AG212		NC
	AG213		NC
	AG214		NC
	AG215		NC
	AG216		NC
	AG217		NC
	AG218		NC
	AG219		NC
	AG220		NC
	AG221		NC
	AG222		NC
	AG223		NC
	AG224		NC
	AG225		NC
	AG226		NC
	AG227		NC
	AG228		NC
	AG229		NC
	AG230		NC
	AG231		NC
	AG232		NC
	AG233		NC
	AG234		NC
	AG235		NC
	AG236		NC
	AG237		NC
	AG238		NC
	AG239		NC
	AG240		NC
	AG241		NC
	AG242		NC
	AG243		NC
	AG244		NC
	AG245		NC
	AG246		NC
	AG247		NC
	AG248		NC
	AG249		NC
	AG250		NC
	AG251		NC
	AG252		NC
	AG253		NC
	AG254		NC
	AG255		NC
	AG256		NC
	AG257		NC
	AG258		NC
	AG259		NC
	AG260		NC
	AG261		NC
	AG262		NC
	AG263		NC
	AG264		NC
	AG265		NC
	AG266		NC
	AG267		NC
	AG268		NC
	AG269		NC
	AG270		NC
	AG271		NC
	AG272		NC
	AG273		NC
	AG274		NC
	AG275		NC
	AG276		NC
	AG277		NC
	AG278		NC
	AG279		NC
	AG280		NC
	AG281		NC
	AG282		NC
	AG283		NC
	AG284		NC
	AG285		NC
	AG286		NC
	AG287		NC
	AG288		NC
	AG289		NC
	AG290		NC
	AG291		NC
	AG292		NC
	AG293		NC
	AG294		NC
	AG295		NC
	AG296		NC
	AG297		NC
	AG298		NC
	AG299		NC
	AG300		NC
	AG301		NC
	AG302		NC
	AG303		NC
	AG304		NC
	AG305		NC
	AG306		NC
	AG307		NC
	AG308		NC
	AG309		NC
	AG310		NC
	AG311		NC
	AG312		NC
	AG313		NC
	AG314		NC
	AG315		NC
	AG316		NC
	AG317		NC
	AG318		NC
	AG319		NC
	AG320		NC
	AG321		NC
	AG322		NC
	AG323		NC
	AG324		NC
	AG325		NC
	AG326		NC
	AG327		NC
	AG328		NC
	AG329		NC
	AG330		NC
	AG331		NC
	AG332		NC
	AG333		NC
	AG334		NC
	AG335		NC
	AG336		NC
	AG337		NC
	AG338		NC
	AG339		NC
	AG340		NC
	AG341		NC
	AG342		NC
	AG343		NC
	AG344		NC
	AG345		NC
	AG346		NC
	AG347		NC
	AG348		NC
	AG349		NC
	AG350		NC
	AG351		NC
	AG352		NC
	AG353		NC
	AG354		NC
	AG355		NC
	AG356		NC
	AG357		NC
	AG358		NC
	AG359		NC
	AG360		NC
	AG361		NC
	AG362		NC
	AG363		NC
	AG364		NC
	AG365		NC
	AG366		NC
	AG367		NC
	AG368		NC
	AG369		NC
	AG370		NC
	AG371		NC
	AG372		NC
	AG373		NC
	AG374		NC
	AG375		NC
	AG376		NC
	AG377		NC
	AG378		NC
	AG379		NC
	AG380		NC
	AG381		NC
	AG382		NC
	AG383		NC
	AG384		NC
	AG385		NC
	AG386		NC
	AG387		NC
	AG388		NC

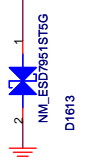
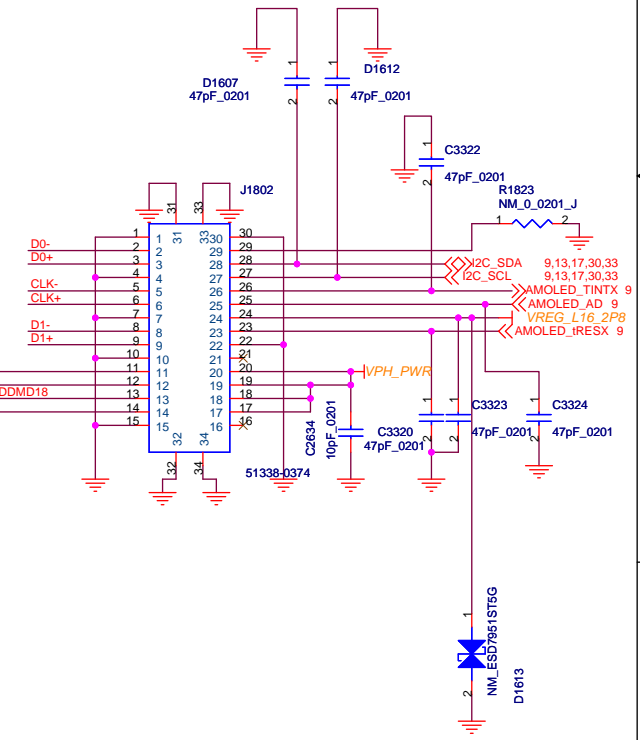
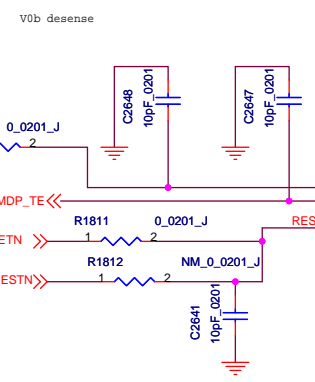
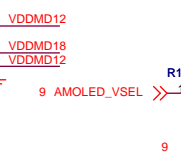
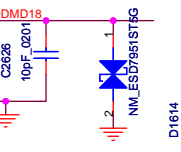
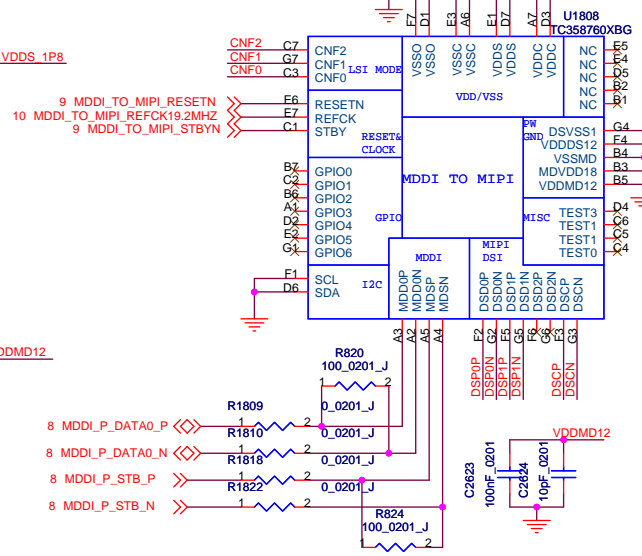
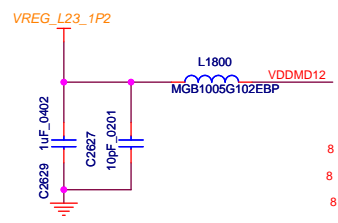
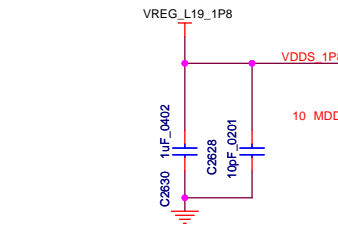
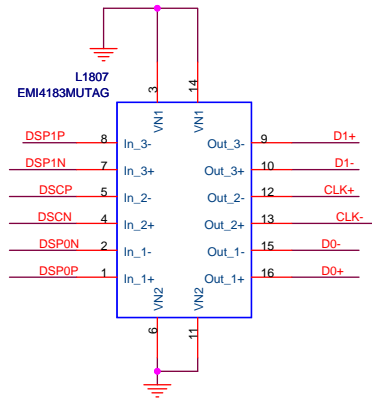
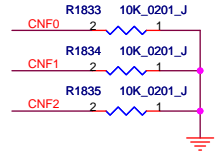

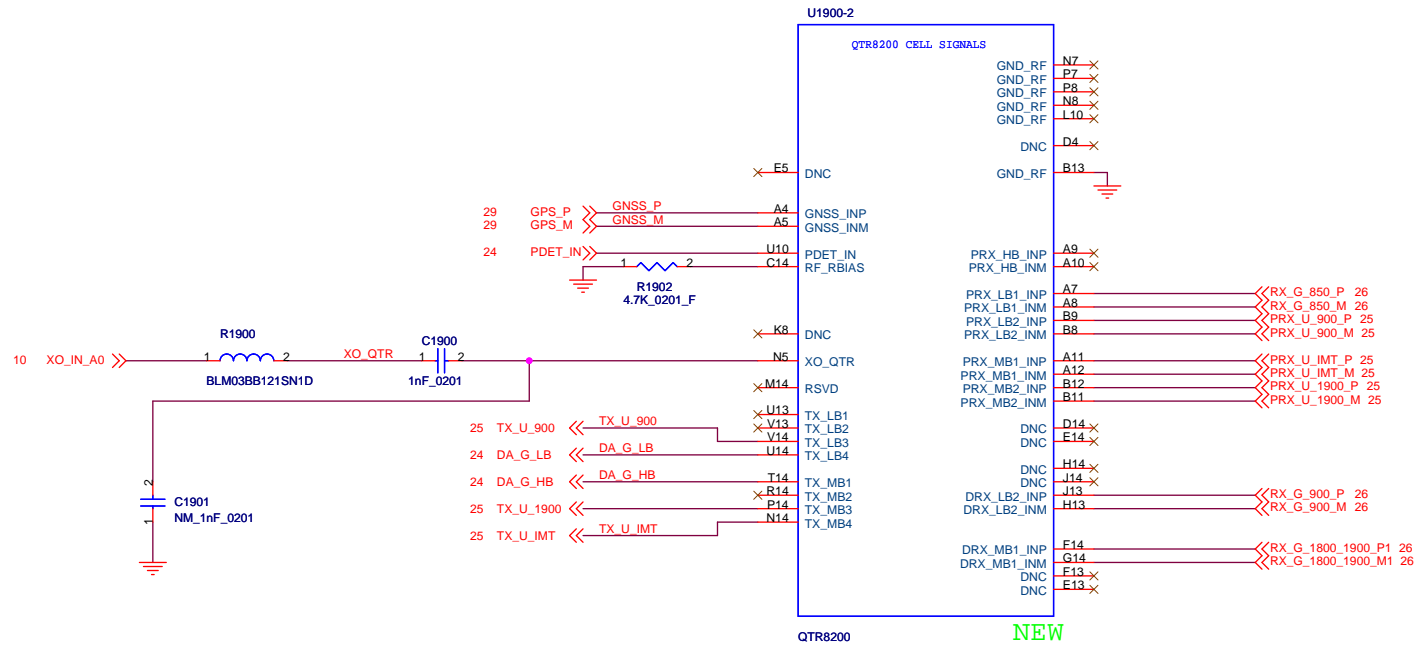

QTR LNA input and driver output pins have 1.3V DC present, attention must be paid to DC blocking requirements based on customer implementation of matching components, filters, PA's etc

NEW

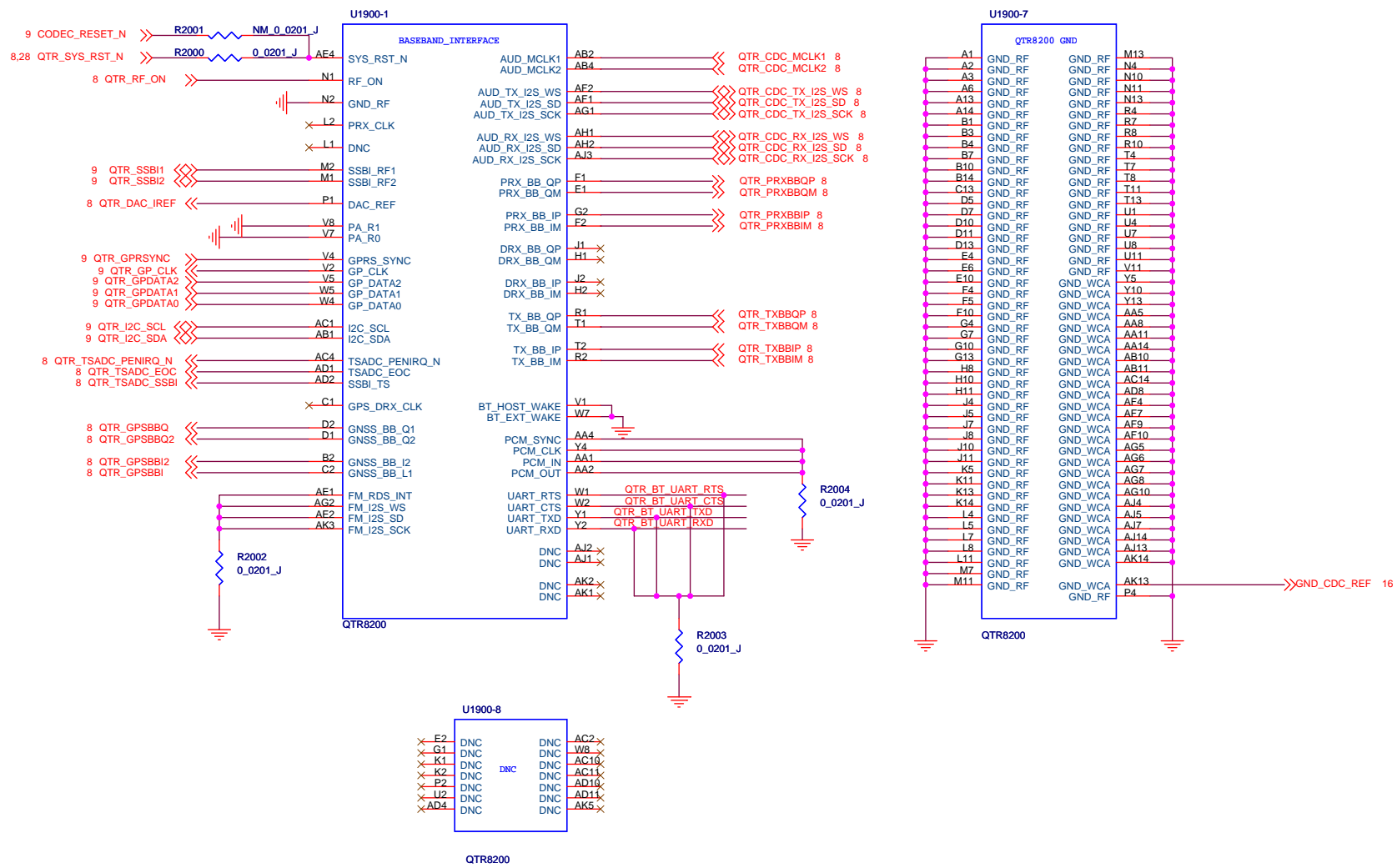

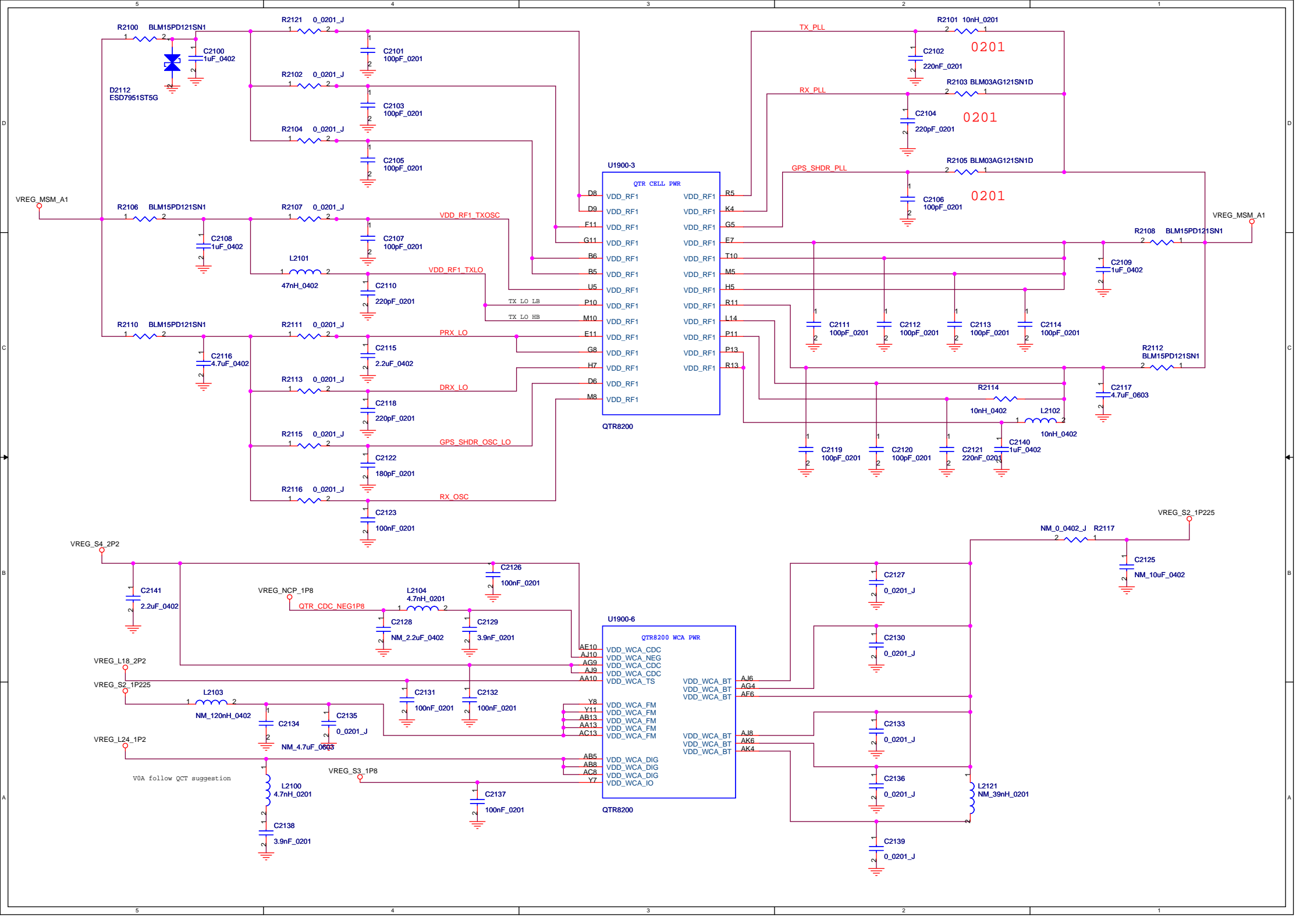

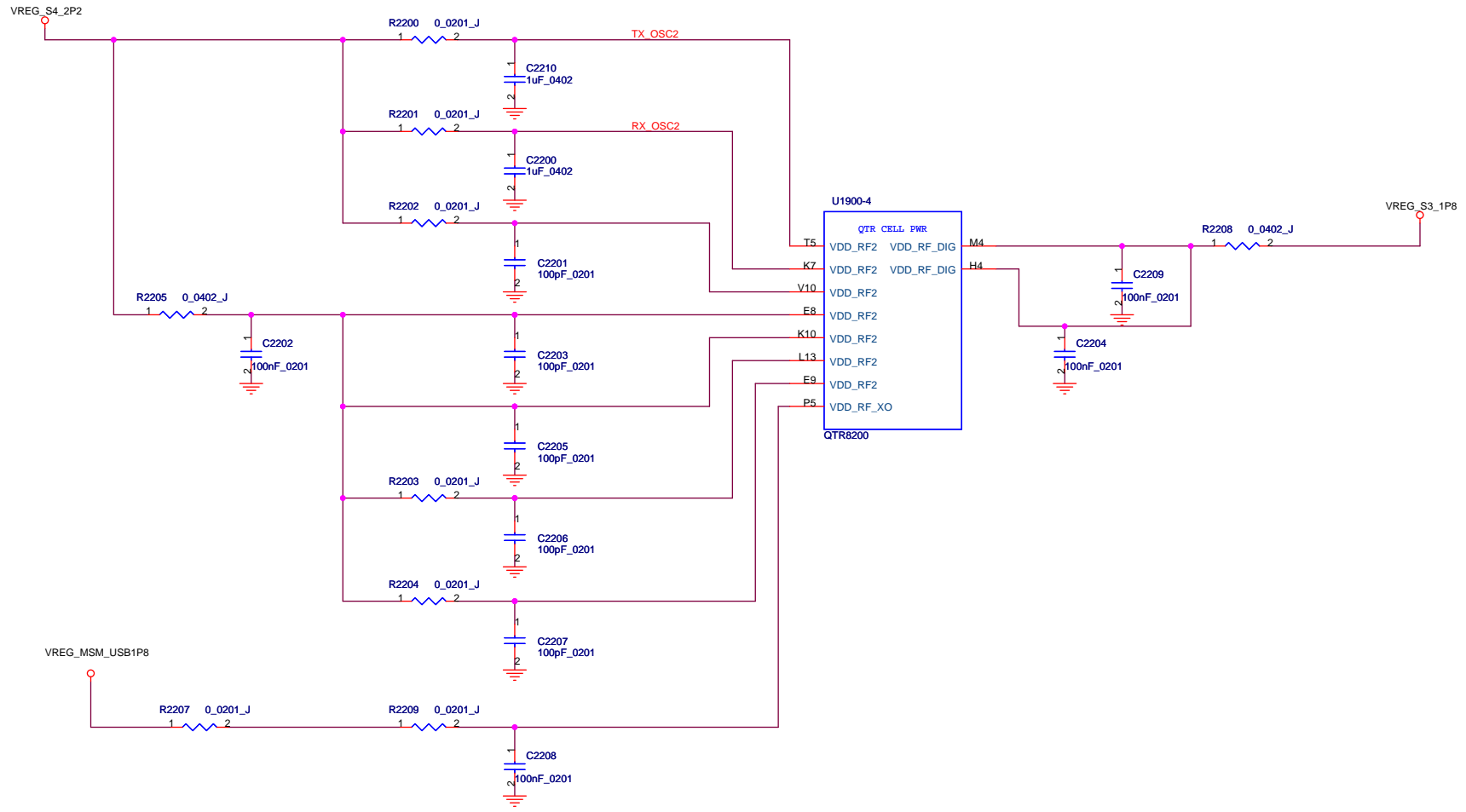

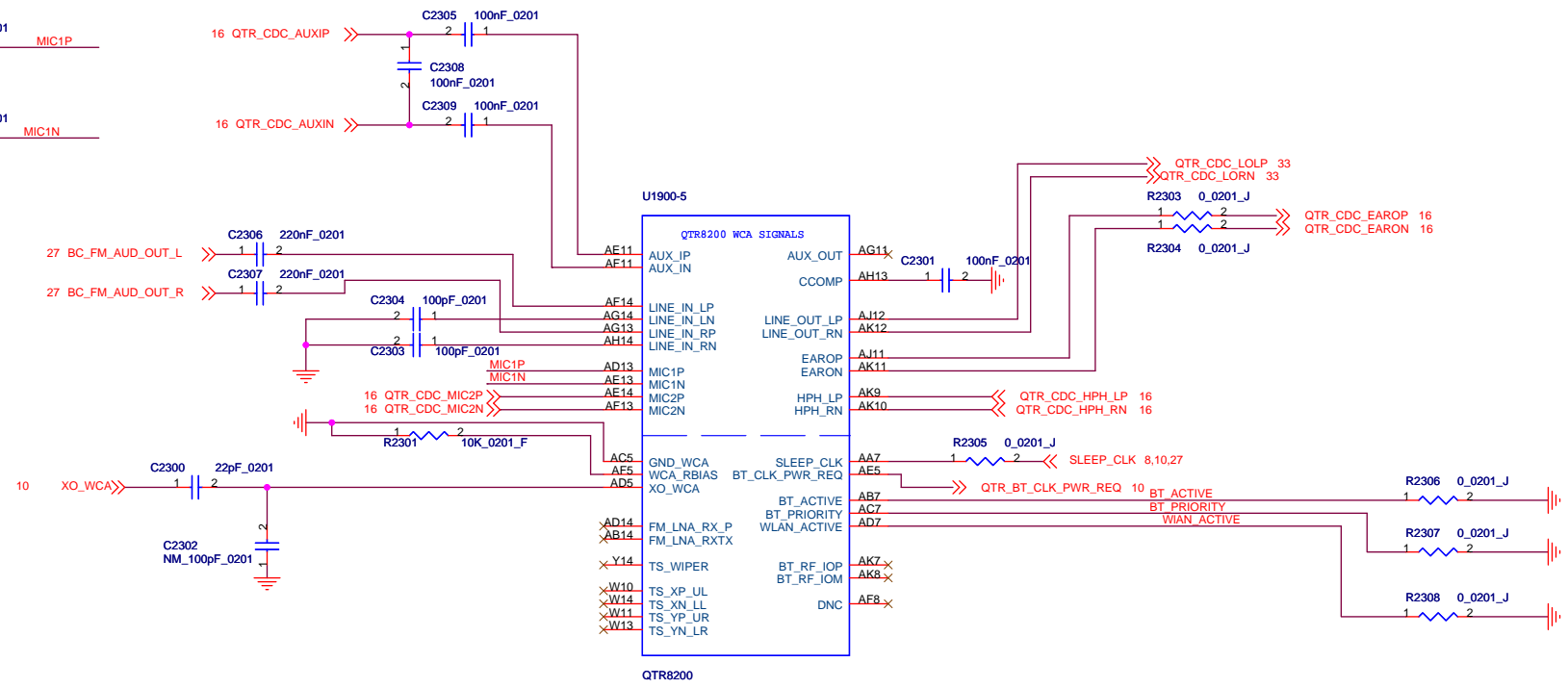
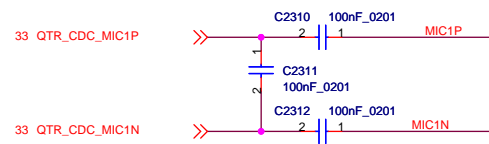

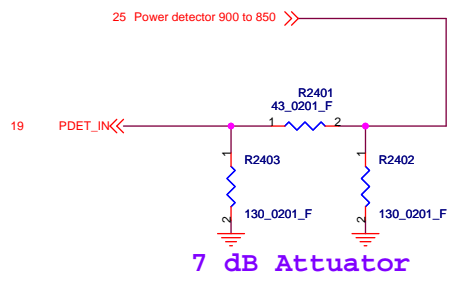
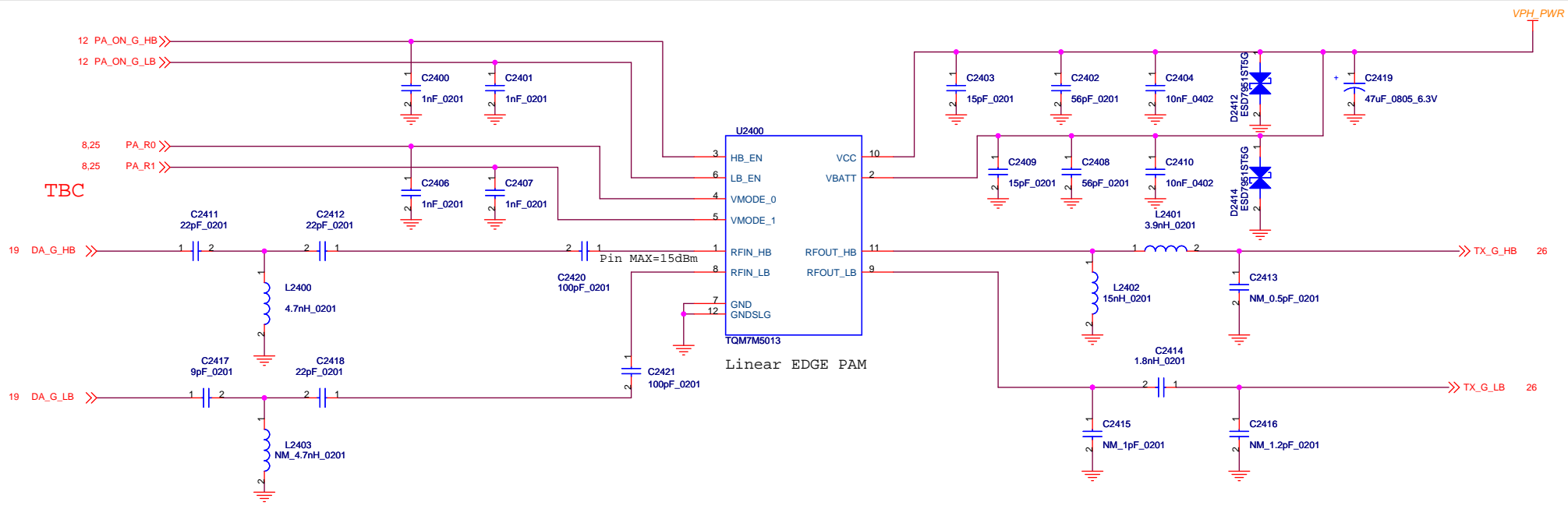

	POWER MODE	PA_ON_G_LB	PA_ON_G_HB	PA_R0	PA_R1
OFF MODE	POWER DOWN	L	L	X	X
LOW BAND	LB HIGH POWER	H	L	L	L
	LB MID POWER	H	L	L	H
	LB LOW POWER	H	L	H	L
	LB ULTRA LOW POWER	H	L	H	H
HIGH BAND	HB HIGH POWER	L	H	L	L
	HB LOW POWER	L	H	H	L
	HB ULTRA LOW POWER	L	H	H	H

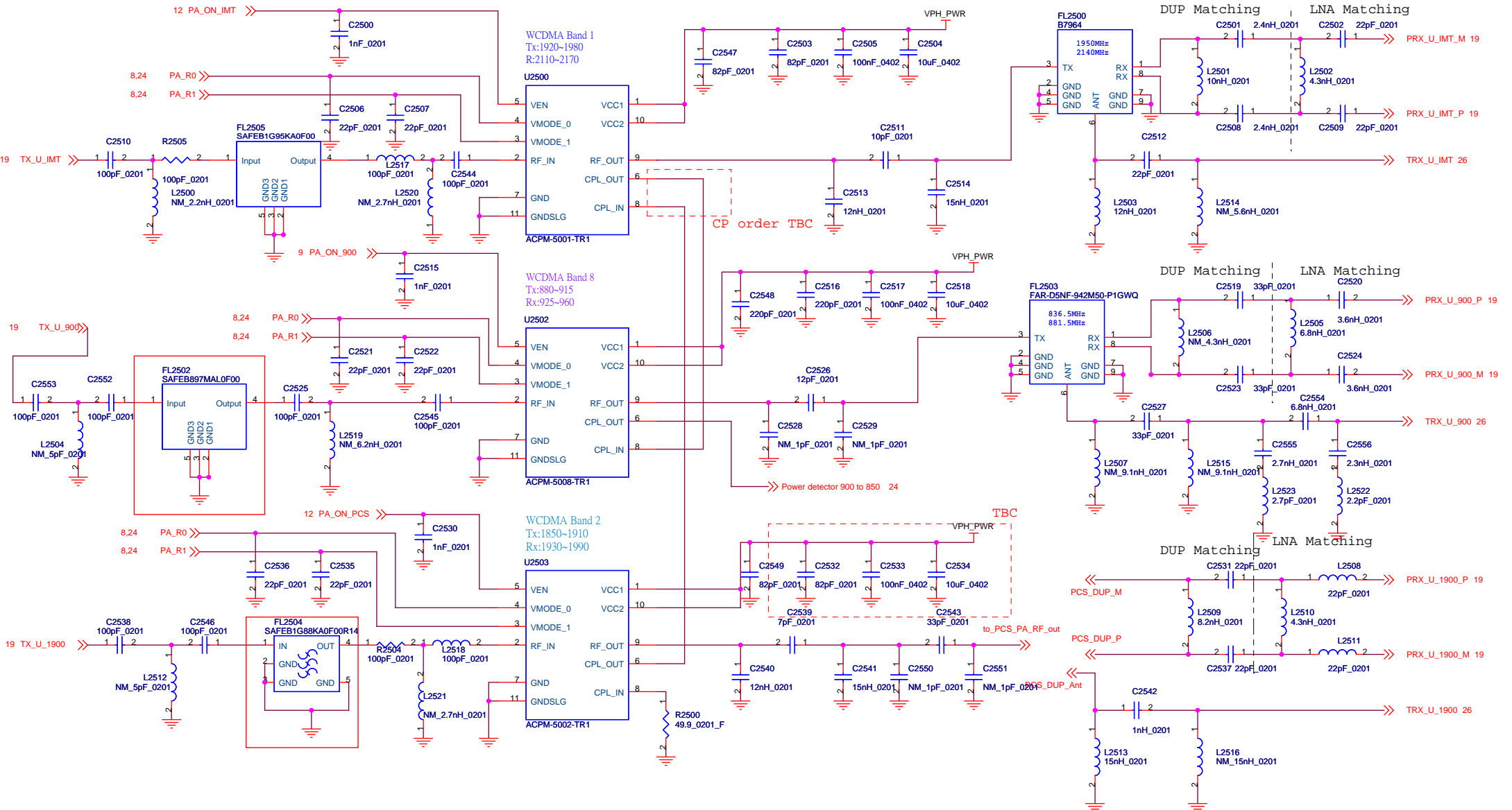

POWER MODE	PA_R0	PA_R1
LOW POWER	H	H
MEDIUM POWER	H	L
HIGH POWER	L	X

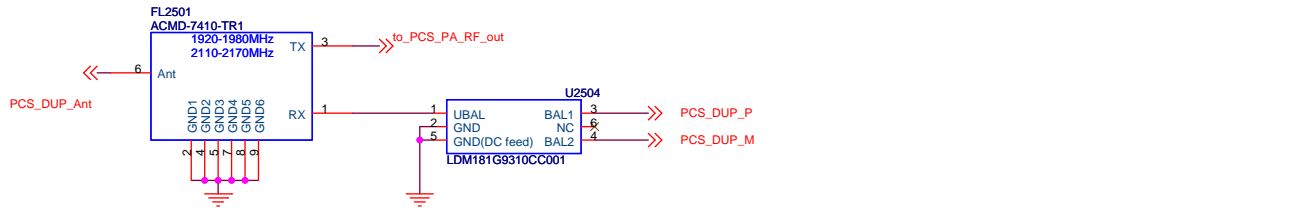

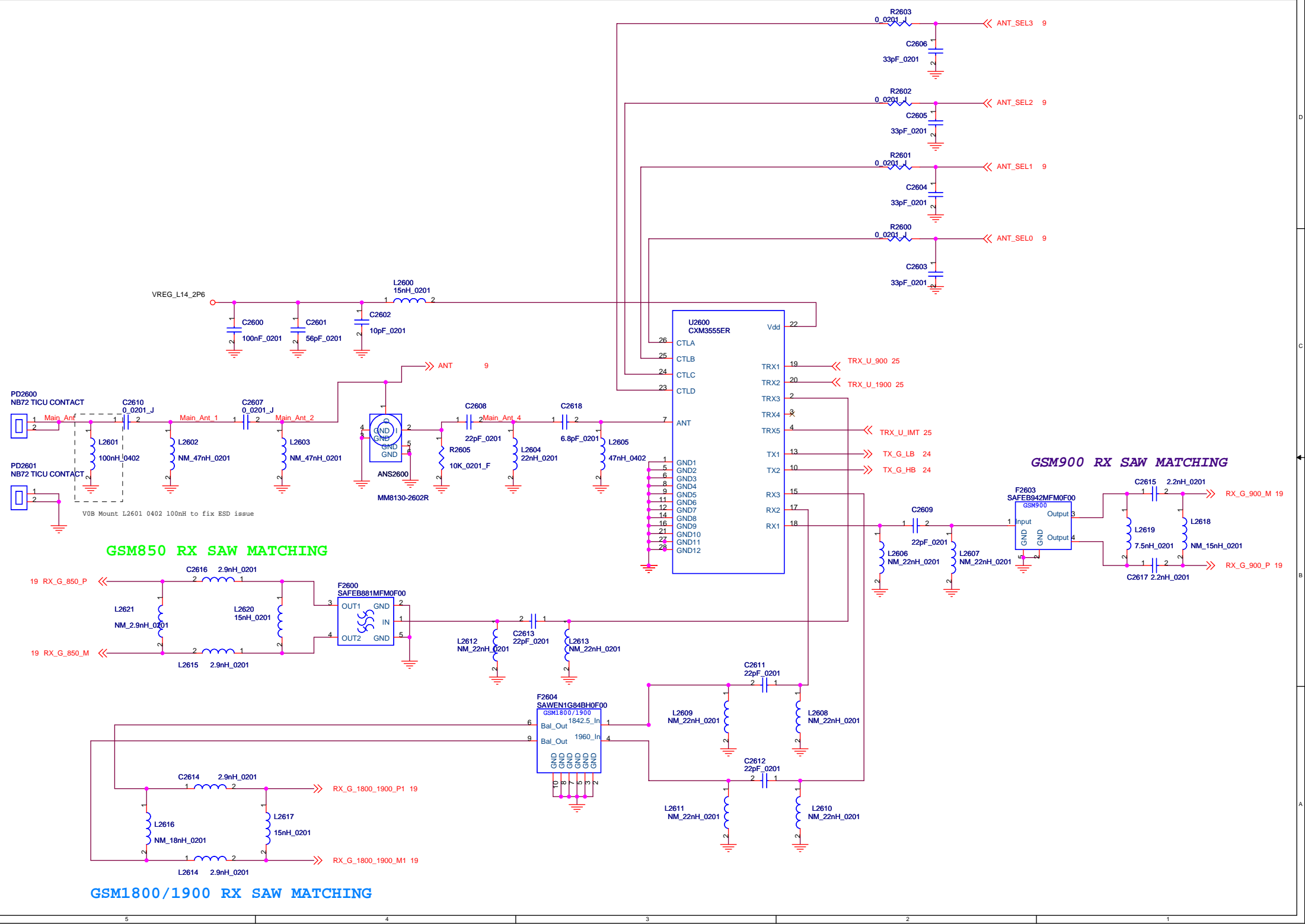

GSM850 RX SAW MATCHING

GSM900 RX SAW MATCHING

GSM1800/1900 RX SAW MATCHING

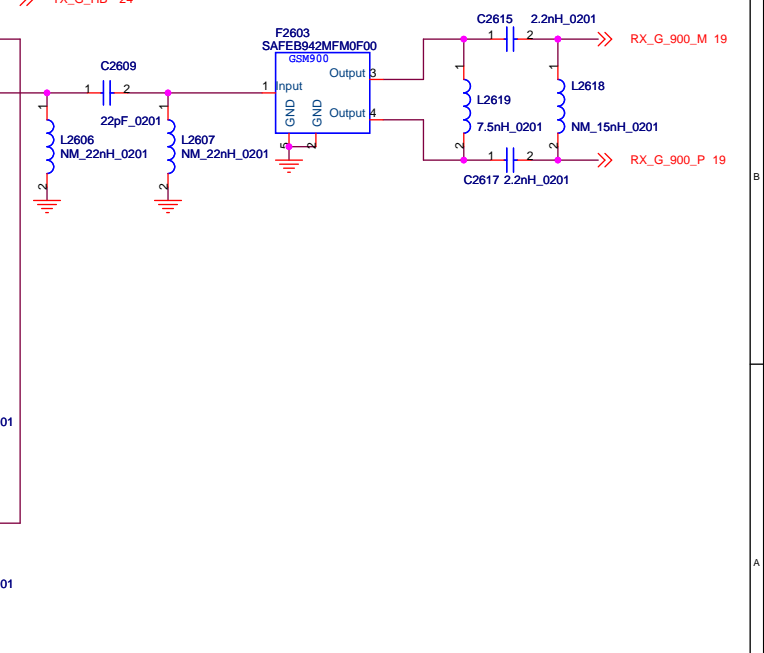
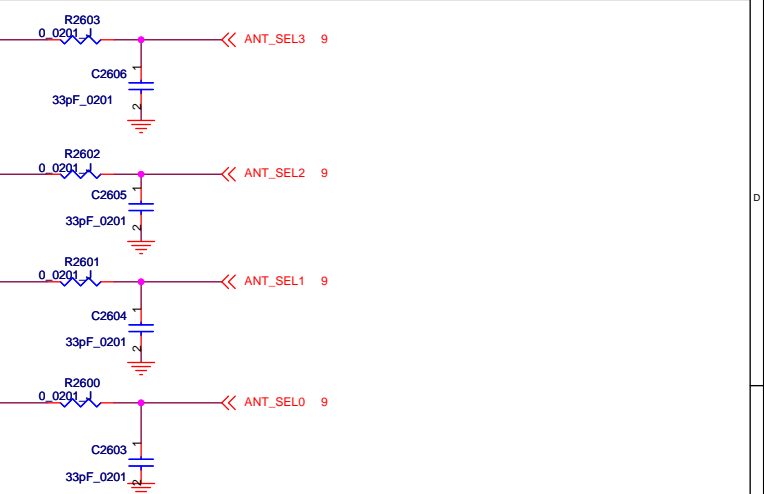
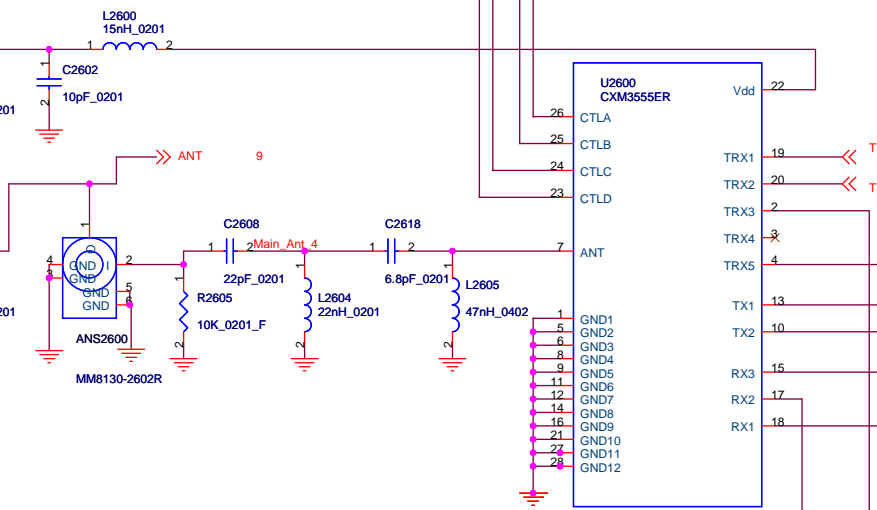
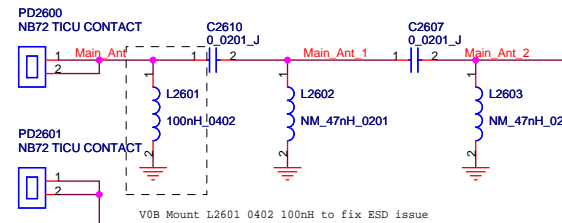

SPRING

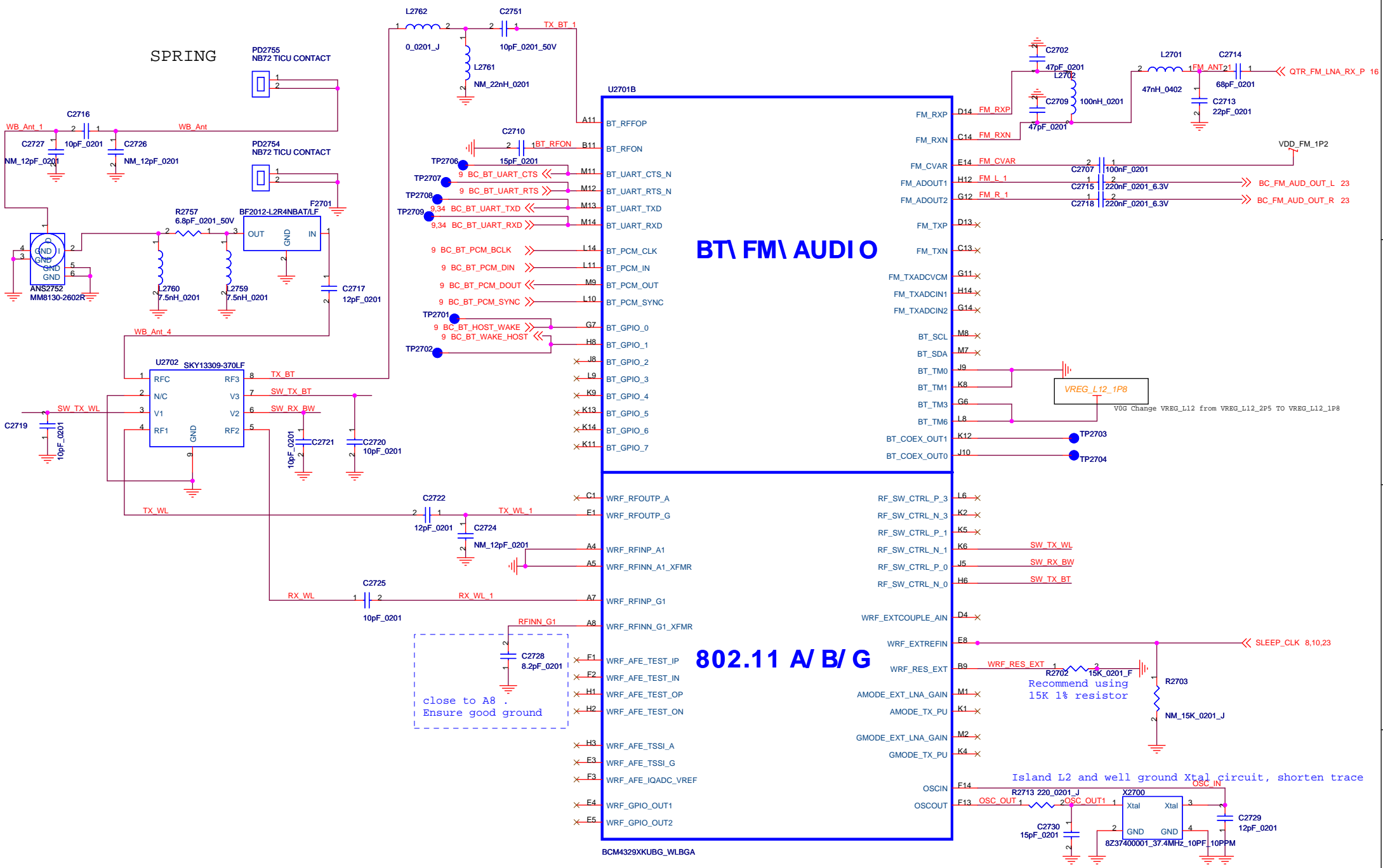

BT FM AUDIO

802.11 A/B/G

close to A8 .
Ensure good ground

Recommend using
15K 1% resistor

Island L2 and well ground Xtal circuit, shorten trace

VDD Change VREG_L12 from VREG_L12_2P5 TO VREG_L12_1P8

BCM4329XKUBG_WLBGA

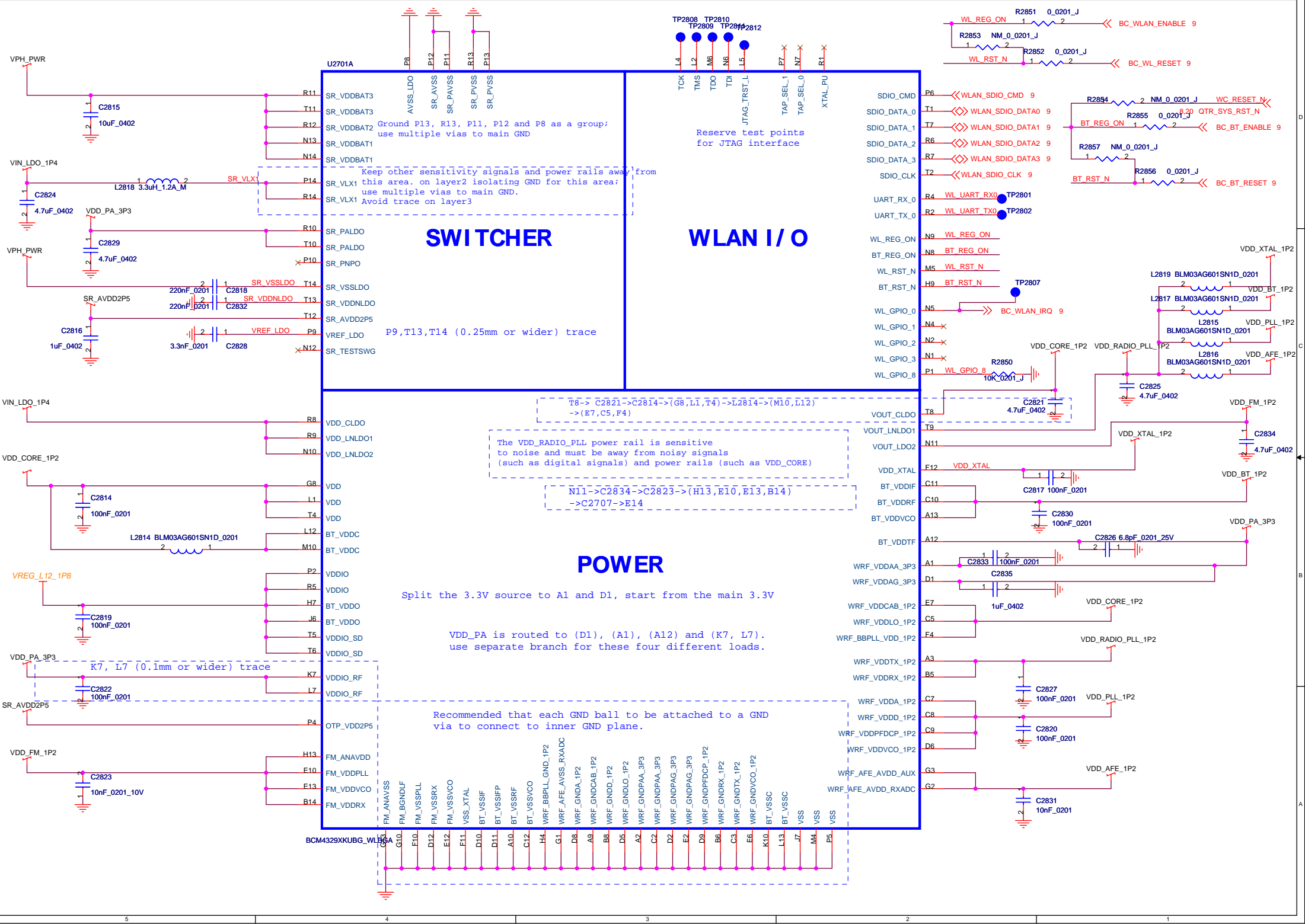

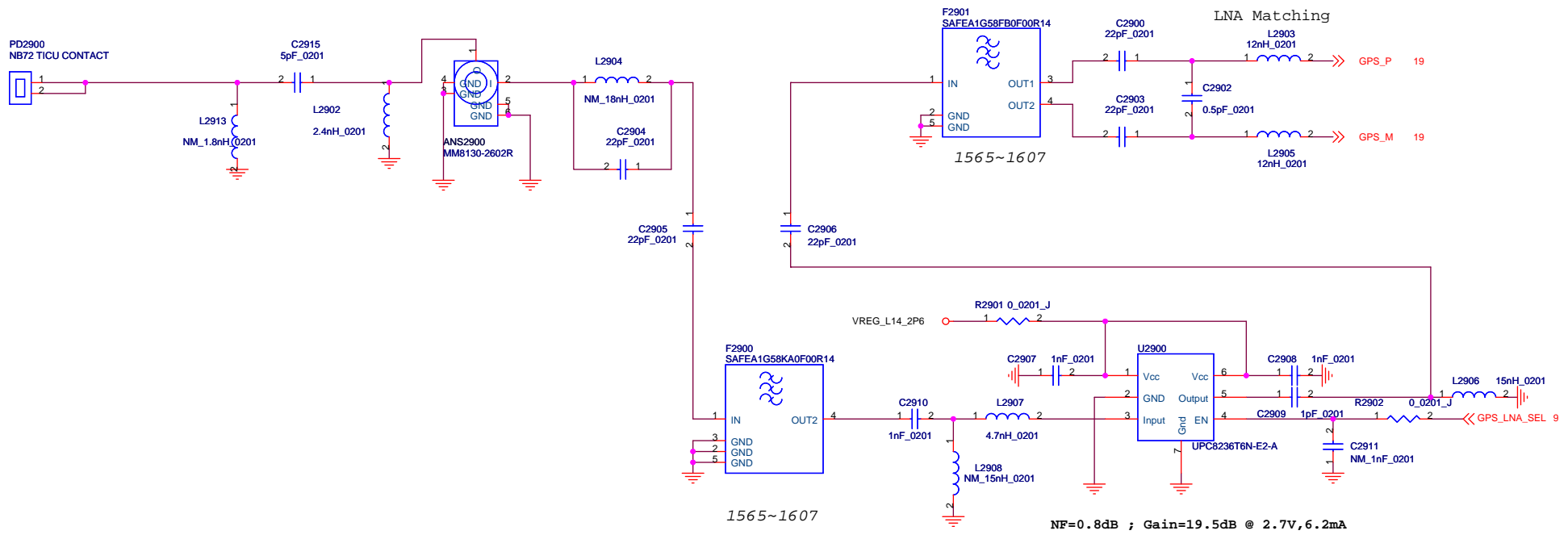

NF=0.8dB ; Gain=19.5dB @ 2.7V, 6.2mA

G-Sensor

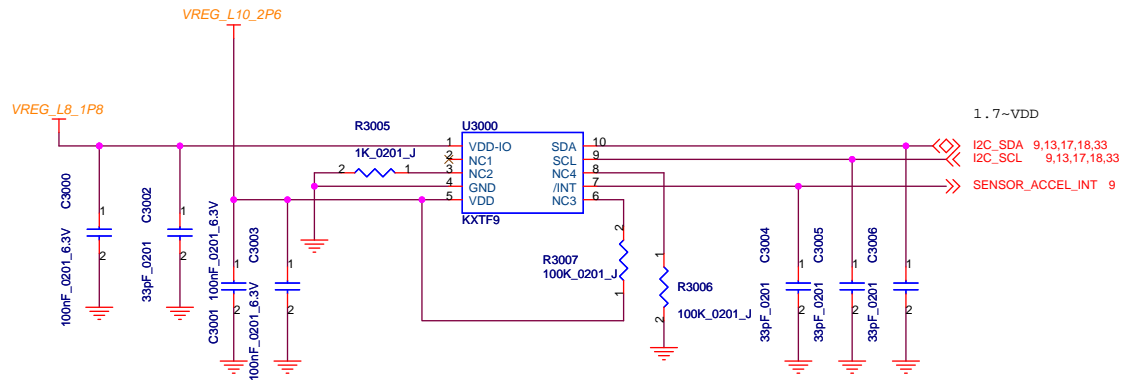

E-Compass

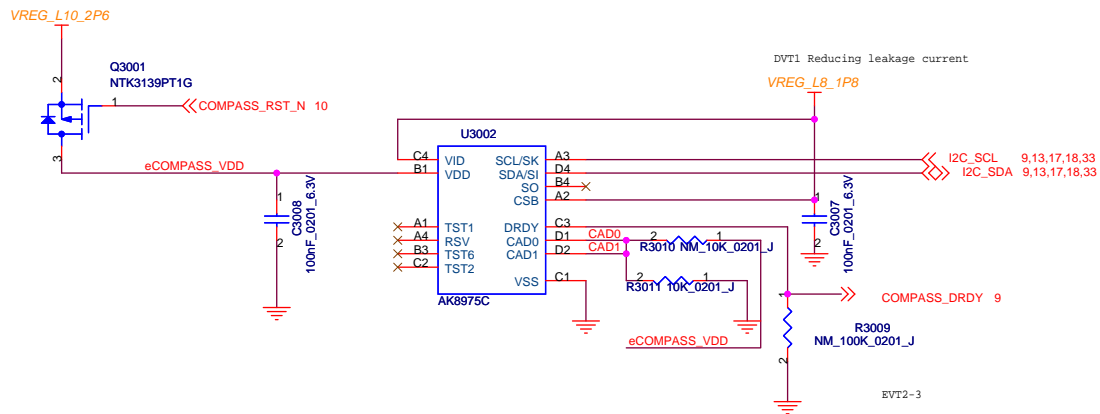

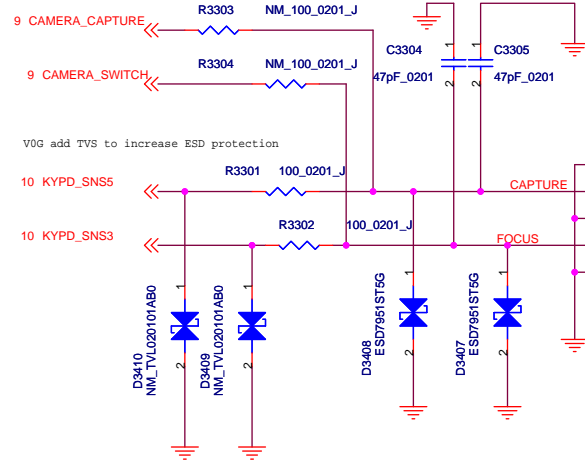
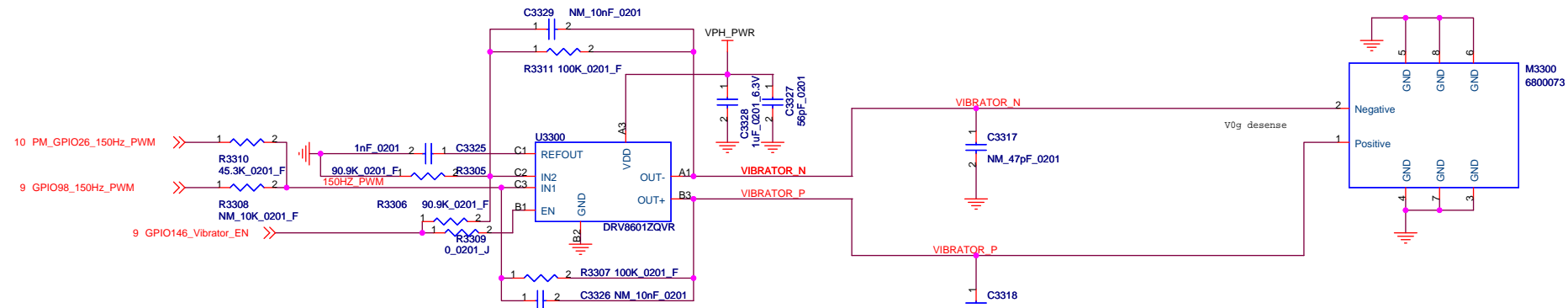

Side Key

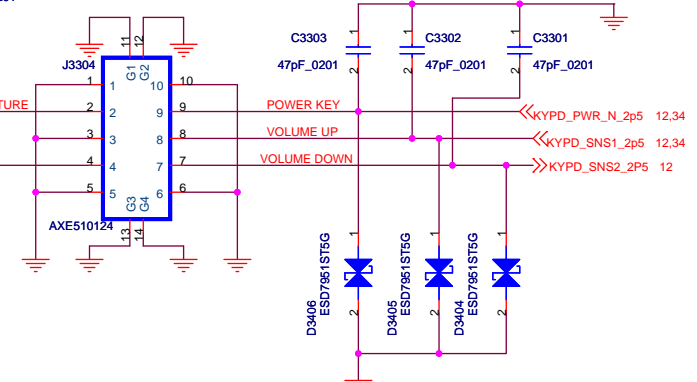

Audio Jack

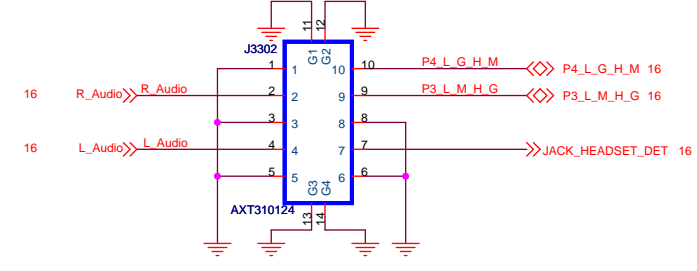

Light & Proximity

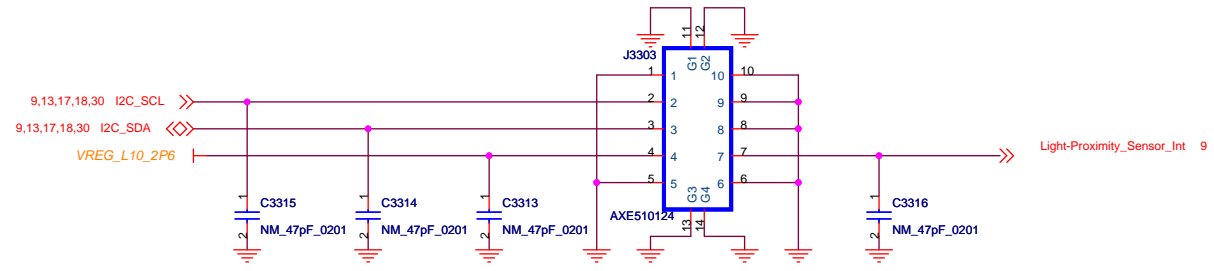

Microphone RIGHT & Speaker

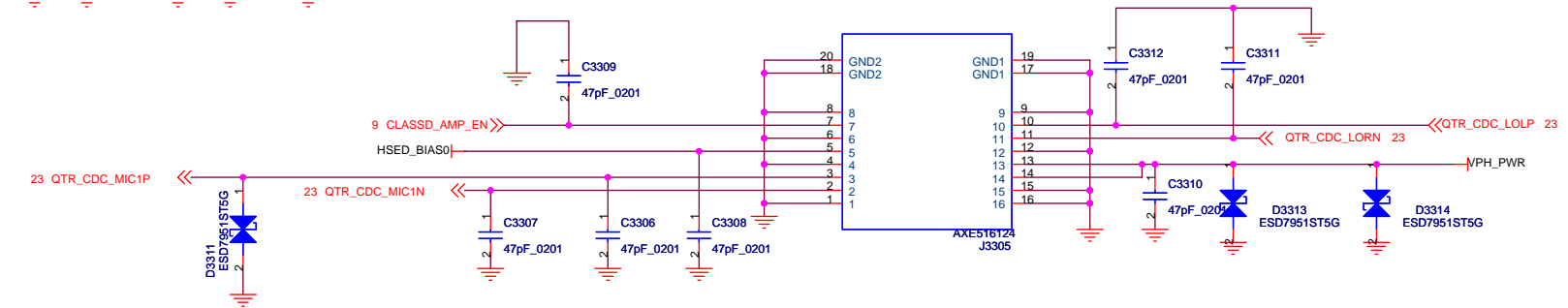

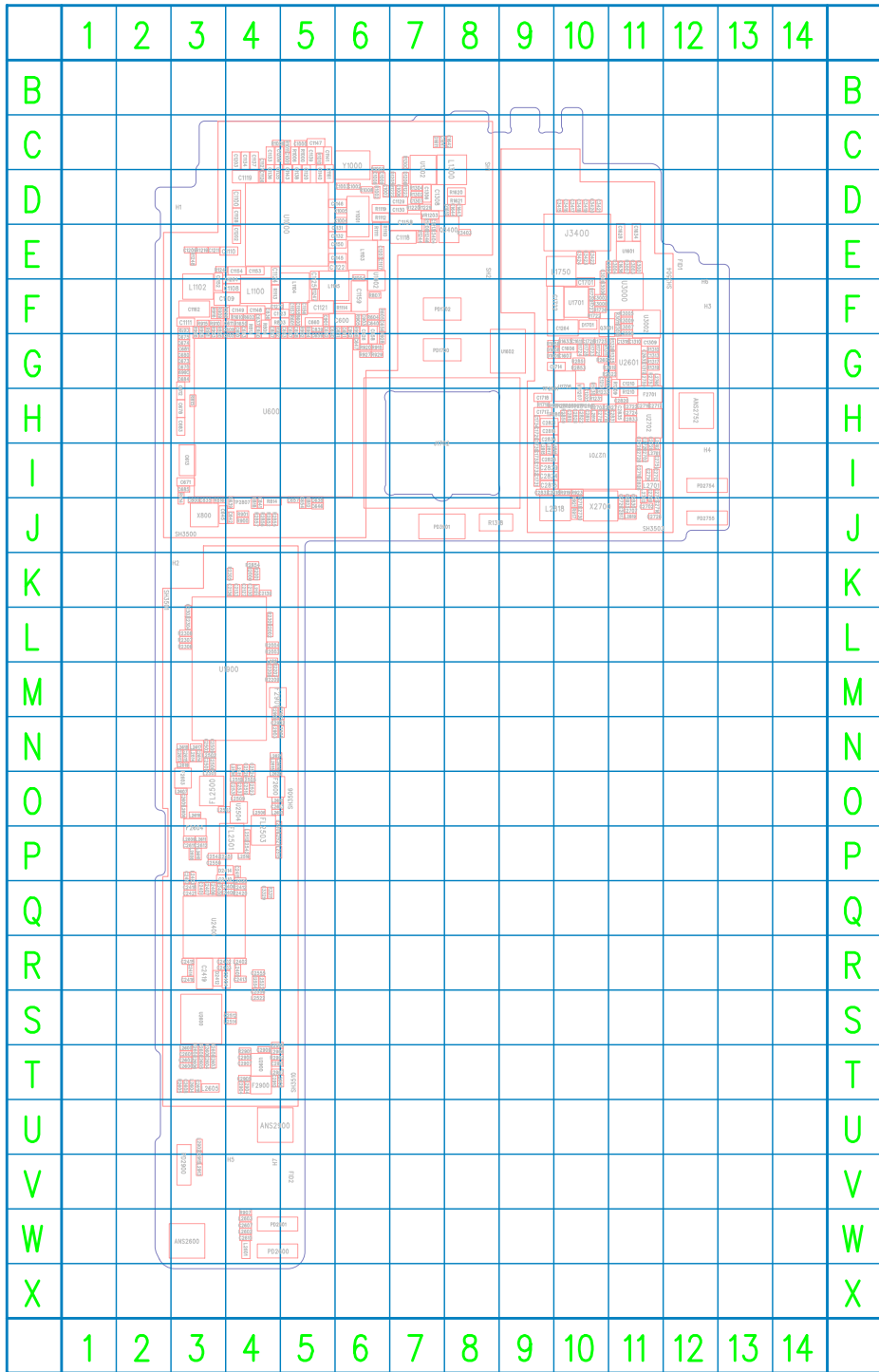

AN	C1149	F4	C2555	R4	D1609	G9	Q3001	F10	R1727	F10	
ANS2000	W3	C1150	E5	C2556	S4	D1610	D8	Q3400	E8	R1728	G10
ANS2752	H12	C1152	F3	C2600	T3	D1611	C7		R	R2000	K4
ANS2900	U4	C1153	F4	C2601	T3	D1701	F10	R600	F5	R2001	K4
C	C1154	E4	C2602	T3	D2412	R3	R601	F4	R2002	L4	
C600	F6	C1155	F5	C2603	T3	D2414	P3	R602	F6	R2003	L4
C605	G4	C1156	F5	C2604	T3		F	R604	F6	R2004	L4
C609	F4	C1157	F5	C2605	T3	F2600	O4	R605	F6	R2007	M4
C610	F4	C1158	D7	C2606	T3	F2603	O3	R800	F5	R2009	M4
C612	G3	C1159	F6	C2607	W4	F2604	W4	R803	F3	R2301	L4
C613	I3	C1161	D5	C2608	T3	F2701	H11	R805	F4	R2305	K4
C619	F3	C1162	F3	C2609	O3	F2900	T4	R807	F6	R2306	L3
C626	F6	C1202	E4	C2610	W4	F2901	M4	R812	J5	R2307	L3
C630	F5	C1203	C4	C2611	W4		F	R813	F4	R2308	L3
C631	F6	C1204	E4	C2612	W4	FL2500	O3	R814	J4	R2600	T3
C632	F5	C1205	H10	C2613	O4	FL2501	P4	R815	H3	R2601	T3
C637	F4	C1207	E6	C2614	N3	FL2502	O4	R816	J3	R2602	T3
C638	J5	C1208	C4	C2615	N3		L	R818	J4	R2603	T3
C639	J4	C1209	E3	C2616	N4	H1702	H7	R900	J4	R2605	T3
C640	F6	C1210	G11	C2617	N3	I3400	E10	R901	J4	R2607	G10
C642	J4	C1211	E3	C2618	F3		L	R902	F5	R2619	G10
C643	F4	C1212	E7	C2352	G11	L900	L4	R903	F3	R2622	G10
C645	J3	C1213	G10	C2702	I11	L1100	F4	R904	F5	R2702	I11
C646	J5	C1214	F10	C2707	I11	L1102	F3	R905	F6	R2703	H10
C647	G6	C1272	E4	C2709	I11	L1103	E6	R906	F6	R2713	I10
C654	J5	C1306	D7	C2710	I11	L1104	F5	R907	W4	R2757	G11
C656	F6	C1307	D7	C2713	I11	L1105	F5	R908	F4	R2850	H10
C657	J5	C1308	D7	C2714	I11	L1300	C8	R909	F3	R2851	G10
C658	F6	C1309	G11	C2715	H10	L1750	E10	R910	F3	R2852	J4
C659	G5	C1310	G11	C2716	I11	L2121	K4	R911	F3	R2853	G10
C660	F5	C1313	G11	C2717	H11	L2400	P4	R912	F4	R2854	K4
C661	F6	C1316	G11	C2718	H10	L2401	R4	R914	I3	R2855	J4
C663	F5	C1317	G11	C2719	H11	L2402	R4	R915	F3	R2856	J4
C665	F5	C1606	G10	C2720	H11	L2403	P3	R916	F3	R2857	J4
C669	G3	C1607	G10	C2721	I11	L2501	O3	R917	I10	R2901	T4
C670	G3	C1611	G10	C2722	H11	L2502	N3	R918	I10	R2902	T4
C671	I3	C1628	E11	C2724	H11	L2503	O3	R919	G6	R3005	F11
C673	G3	C1634	E11	C2725	I11	L2505	O4	R920	I10	R3006	E11
C674	G3	C1636	E11	C2726	I11	L2506	O4	R920	G6	R3007	E11
C675	G3	C1641	C7	C2727	I12	L2507	P4	R921	I10	R3009	F11
C678	H3	C1642	C8	C2728	I11	L2508	N4	R923	I10	R3010	F11
C680	G3	C1643	D8	C2729	I11	L2509	O4	R923	F3	R3011	F11
C681	G3	C1644	D8	C2730	I10	L2510	O4	R926	F3	R3311	O4
C683	H3	C1701	F10	C2751	I11	L2511	N4	R927	G6	R3403	B8
C684	G3	C1714	G10	C2814	H10	L2513	S4	R928	G6	R3404	E7
C685	I3	C1717	H9	C2815	I9	L2514	P4	R929	G6	U	
C800	J3	C1718	H9	C2816	H9	L2515	P4	R1000	C5	U600	H4
C835	J3	C1722	F10	C2817	I11	L2516	P4	R1002	D6	U1000	D5
C836	F4	C1728	G10	C2818	I9	L2522	S4	R1003	C6	U1002	B6
C837	F4	C1729	H9	C2819	H10	L2523	R4	R1004	E6	U1302	C7
C838	F5	C1730	I9	C2820	I11	L2600	T3	R1006	C5	U1601	E11
C839	F3	C1731	I9	C2821	H9	L2601	W4	R1008	D6	U1602	G9
C840	F4	C1732	I9	C2822	H10	L2602	W4	R1009	C4	U1701	F10
C841	J4	C1733	I9	C2823	I11	L2603	W4	R1010	C5	U1706	G10
C901	F5	C1734	H9	C2824	I9	L2604	T3	R1011	C5	U1900	L3
C902	F6	C2127	K3	C2825	I9	L2605	T3	R1110	E6	U2400	Q3
C903	F6	C2130	K4	C2826	I11	L2606	O3	R1111	E6	U2504	Q3
C1000	C5	C2133	K4	C2827	H10	L2607	P3	R1112	D6	U2600	S3
C1001	C5	C2136	K4	C2828	H10	L2608	S3	R1113	F4	U2601	G11
C1002	D6	C2139	K4	C2829	I9	L2609	F3	R1114	F6	U2701	I10
C1003	D6	C2208	M4	C2830	I11	L2610	P3	R1119	D6	U2702	H11
C1004	D6	C2303	L3	C2831	H11	L2611	P3	R1200	E7	U2900	T4
C1005	D6	C2304	L3	C2832	H9	L2612	O4	R1209	G11	U3000	F11
C1006	D7	C2400	Q3	C2833	H11	L2613	O4	R1210	H11	U3002	F11
C1007	D6	C2401	Q3	C2834	H9	L2614	N3	R1219	E3	VR	
C1008	D6	C2402	R3	C2835	H11	L2615	N4	R1220	D7	VR1203	D7
C1009	D6	C2403	R3	C2900	M4	L2616	O3	R1222	D7	VR1207	H10
C1100	D4	C2404	R4	C2902	N4	L2617	N3	R1223	D7	X	
C1108	F4	C2406	Q3	C2903	M5	L2618	N3	R1229	D7	X300	J3
C1109	F3	C2407	Q3	C2904	T4	L2619	N3	R1230	G10	X2700	I10
C1110	E4	C2408	Q3	C2905	T4	L2620	O4	R1231	H10	Y	
C1111	F3	C2409	Q4	C2906	T4	L2621	N4	R1232	H10	Y1000	C6
C1117	E6	C2410	P5	C2907	T4	L2701	I11	R1242	E3	Y1001	D6
C1118	E7	C2411	P4	C2908	T4	L2702	I11	R1244	E7		
C1119	D4	C2412	P4	C2909	T4	L2759	G11	R1246	E7		
C1120	D5	C2413	R4	C2910	T4	L2760	G11	R1247	F5		
C1121	F5	C2414	R3	C2911	T4	L2761	I11	R1248	E3		
C1122	E5	C2415	R3	C2915	V3	L2762	H11	R1300	C7		
C1123	F4	C2416	R3	C3000	F10	L2814	H10	R1302	D7		
C1124	E4	C2417	P5	C3001	E11	L2815	I9	R1304	D7		
C1125	E5	C2418	Q3	C3002	F10	L2816	I10	R1310	G11		
C1126	D4	C2419	R3	C3003	E11	L2817	I9	R1311	G10		
C1127	C4	C2420	Q4	C3004	E11	L2818	I9	R1317	G11		
C1128	D4	C2421	Q3	C3005	F10	L2819	J11	R1318	B8		
C1129	D7	C2501	N3	C3006	F10	L2902	I3	R1319	G11		
C1130	D7	C2502	N3	C3007	F11	L2903	N4	R1323	G11		
C1131	E6	C2508	N3	C3008	F11	L2904	T4	R1325	G11		
C1132	E6	C2509	N3	C3329	Q4	L2905	N5	R1326	G11		
C1133	C4	C2512	S4	C3415	D10	L2906	T4	R1610	F4		
C1134	C4	C2519	O4	C3416	D10	L2907	T4	R1620	D8		
C1135	D4	C2520	N4	C3417	D10	L2908	T4	R1621	D8		
C1136	D4	C2523	Q4	C3418	D10	L2913	V3	R1653	G10		
C1137	C4	C2524	N4	C3419	D10	L2914	I9	R1650	F4		
C1138	D5	C2527	P4	C3420	D10	PD1700	E7	R1658	G10		
C1139	C5	C2531	O4	C3421	D10	PD1702	F7	R1719	H9		
C1140	D5	C2537	O4	C3422	E10	PD2600	W4	R1720	F10		
C1141	C5	C2542	P4	C3423	E10	PD2601	W4	R1721	G10		
C1143	D5	C2543	P5	C3424	E10	PD2754	I12	R1722	F10		
C1145	E6	C2550	P5		D	PD2755	I12	R1723	G10		
C1146	D6	C2551	P5	D1205	D7	PD2900	U3	R1724	G10		
C1147	C5	C2554	R4	D1206	D7	PD3501	J7	R1725	G10		
C1148	F4	C2553	R4	D1608	C9		Q	R1726	F10		

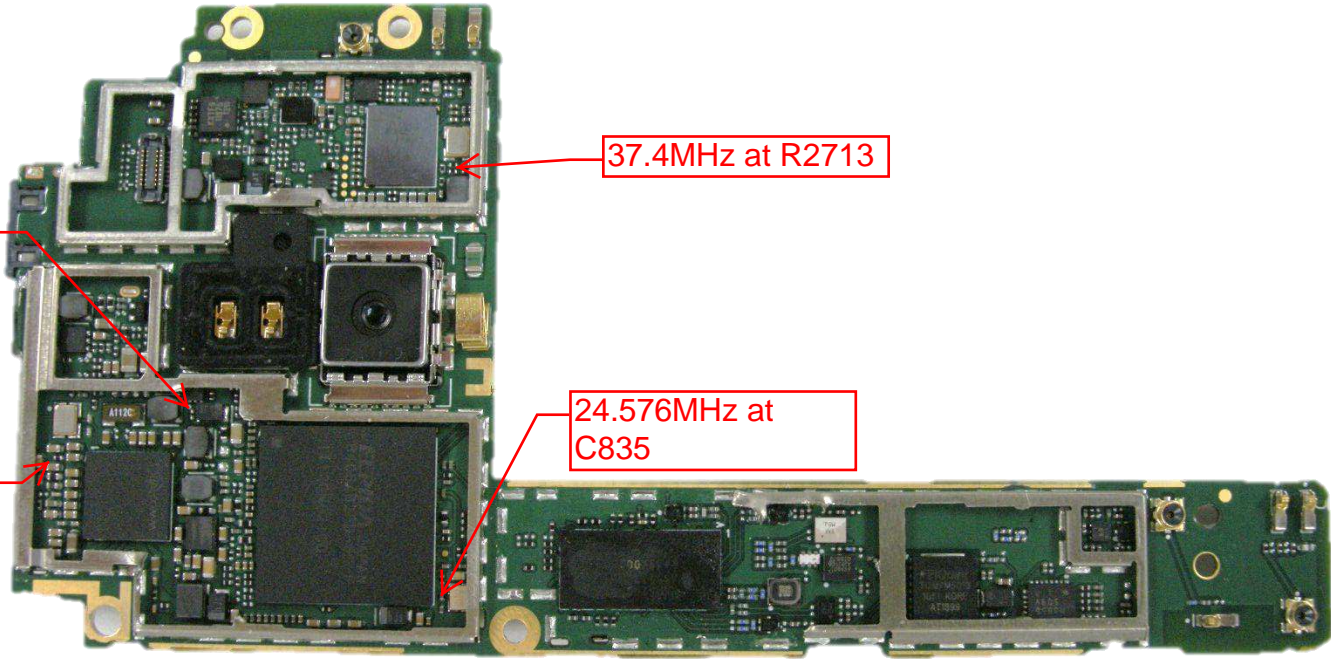

32.768KHz at R1004

37.4MHz at R2713

19.2MHz at R1010

24.576MHz at C835

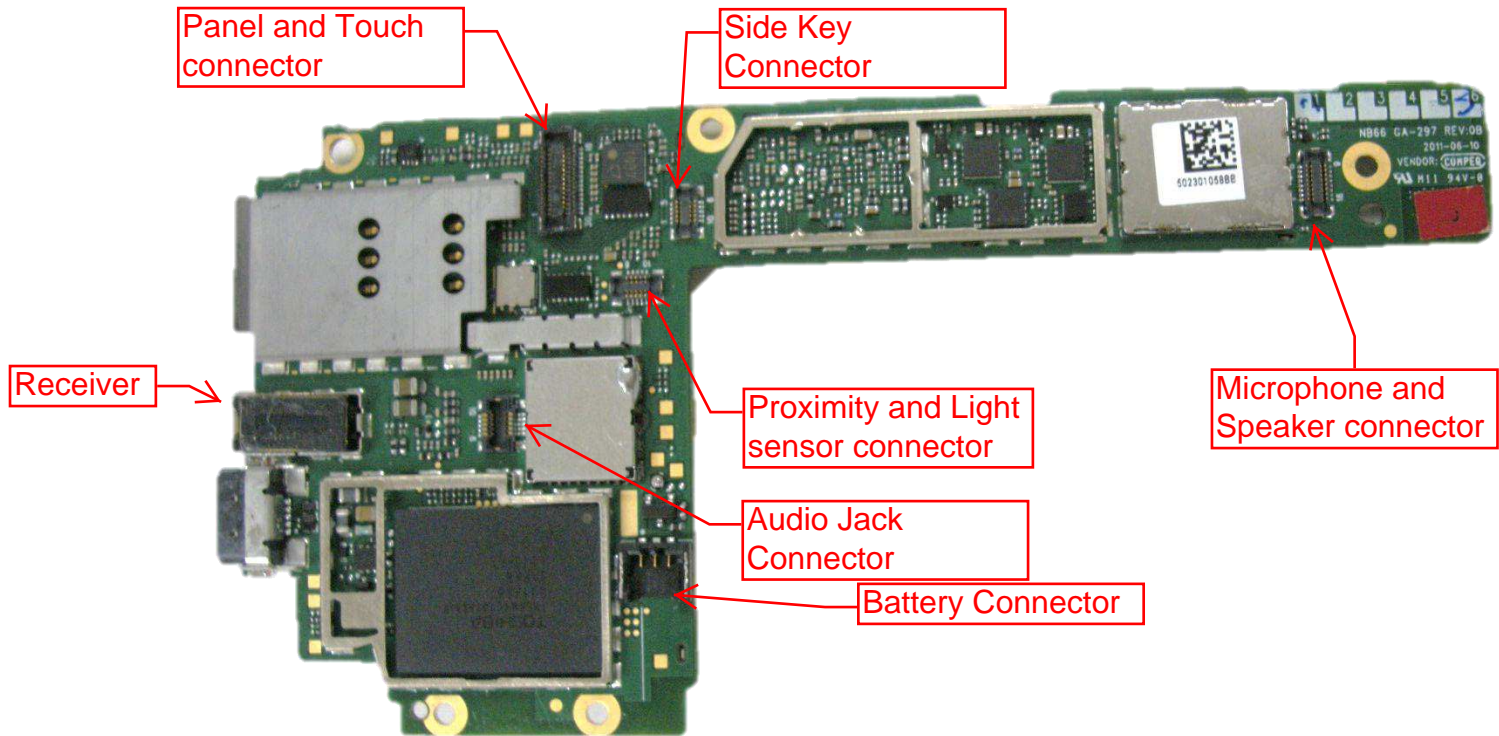

Panel and Touch connector

Side Key Connector

Receiver

Proximity and Light sensor connector

Audio Jack Connector

Battery Connector

Microphone and Speaker connector

www.s-manuals.com