

Service Schematics

NOKIA N76

RM-135/RM-149

Introduction

IMPORTANT:

This document is intended for use by authorized NOKIA service centers only.

“Service Schematics” was created with focus on customer care.
The purpose of this document is to provide further technical repair information for NOKIA mobile phones on Level 3/4 service activities.
It contains additional information such as e.g. “Component finder”.

Saving process time and improving the repair quality is the aim of this document.
It is to be used additionally to the service manual and other training or service information such as Service Bulletins.

All measurements were made using following equipment:

Nokia repair SW : Phoenix version 2006.44.6.163
Oscilloscope : Fluke PM 3380A/B
Spectrum Analyzer : Advantest R3162 with an analog probe
RF-Generator / GSM Tester : Rhode & Schwarz CMU 200
Multimeter : Fluke 73 Series II



Table of Content

Front page	1
AV-, USB-connector	2
AVilma, Betty	3
Rapido, Memories	4
Camera	5
Keyboard	6
Flip PWB	7
RF part	8
Component finder	9

While every endeavour has been made to ensure the accuracy of this document, some errors may exist. If the reader finds any errors, NOKIA shall be notified in writing.

Please send E-Mail to: training.sace@nokia.com

Copyright © NOKIA

This material, including documentation and any related computer programs is protected by copyright, controlled by NOKIA. All rights are reserved. Copying, including reproducing, modifying, storing, adapting or translating any or all of this material requires the prior written consent of NOKIA. This material also contains company confidential information, which may not be disclosed to others without the prior written consent of NOKIA.

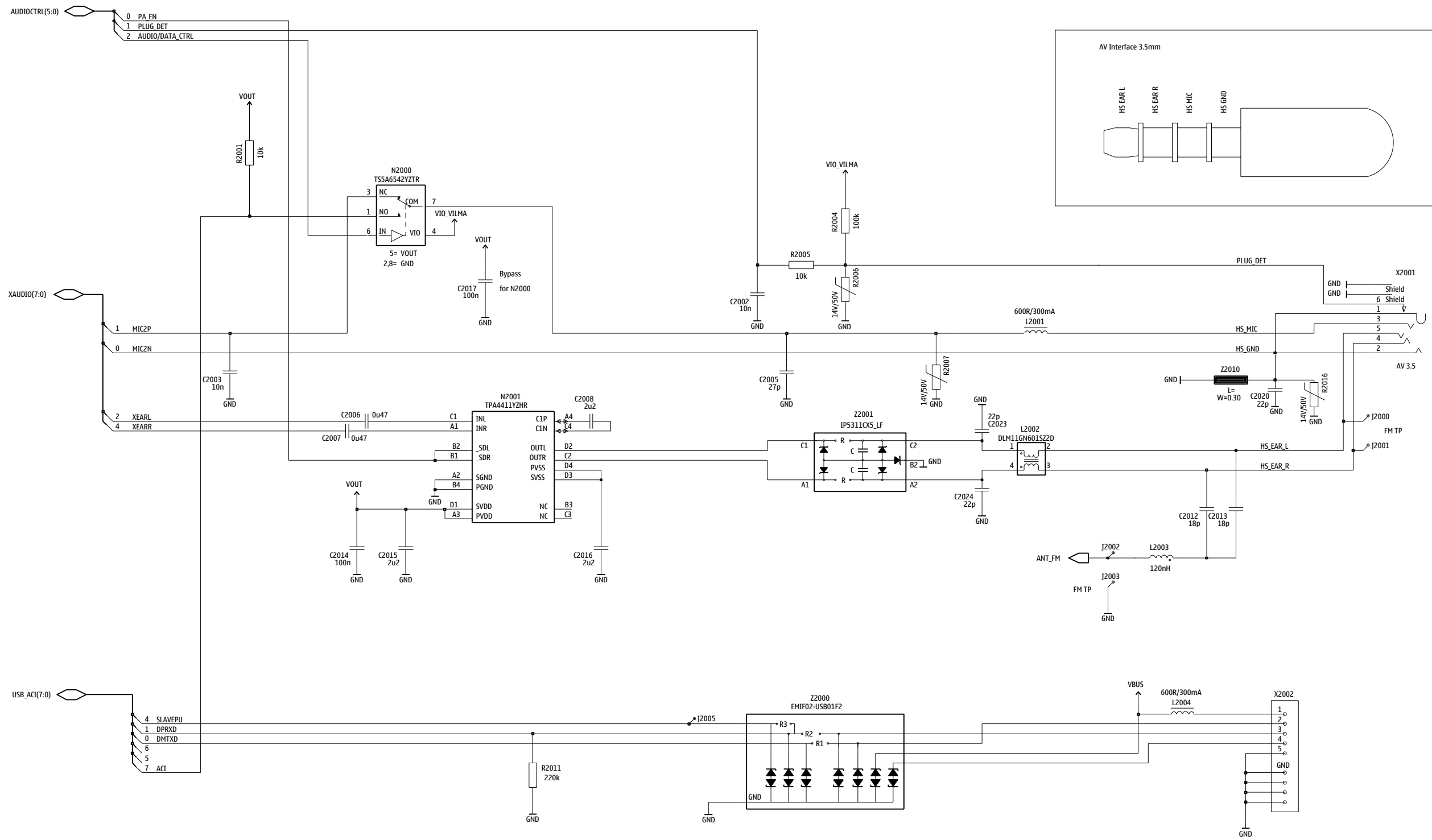

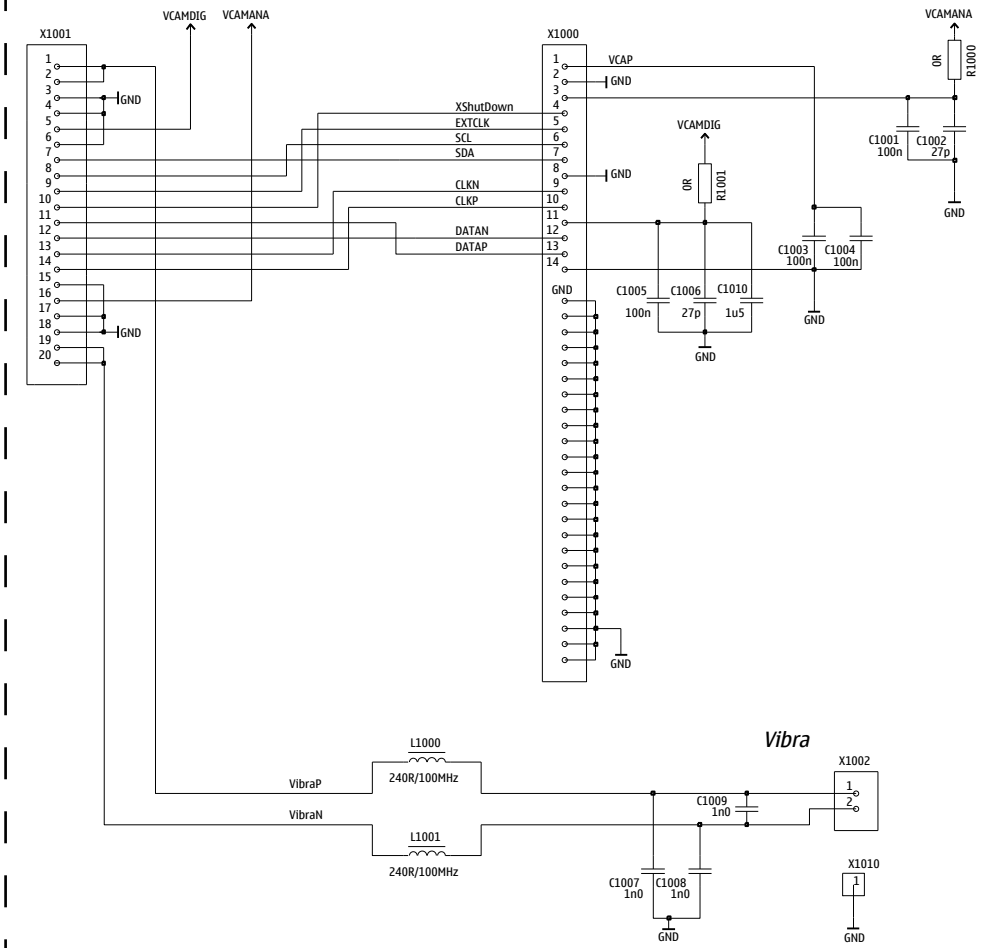
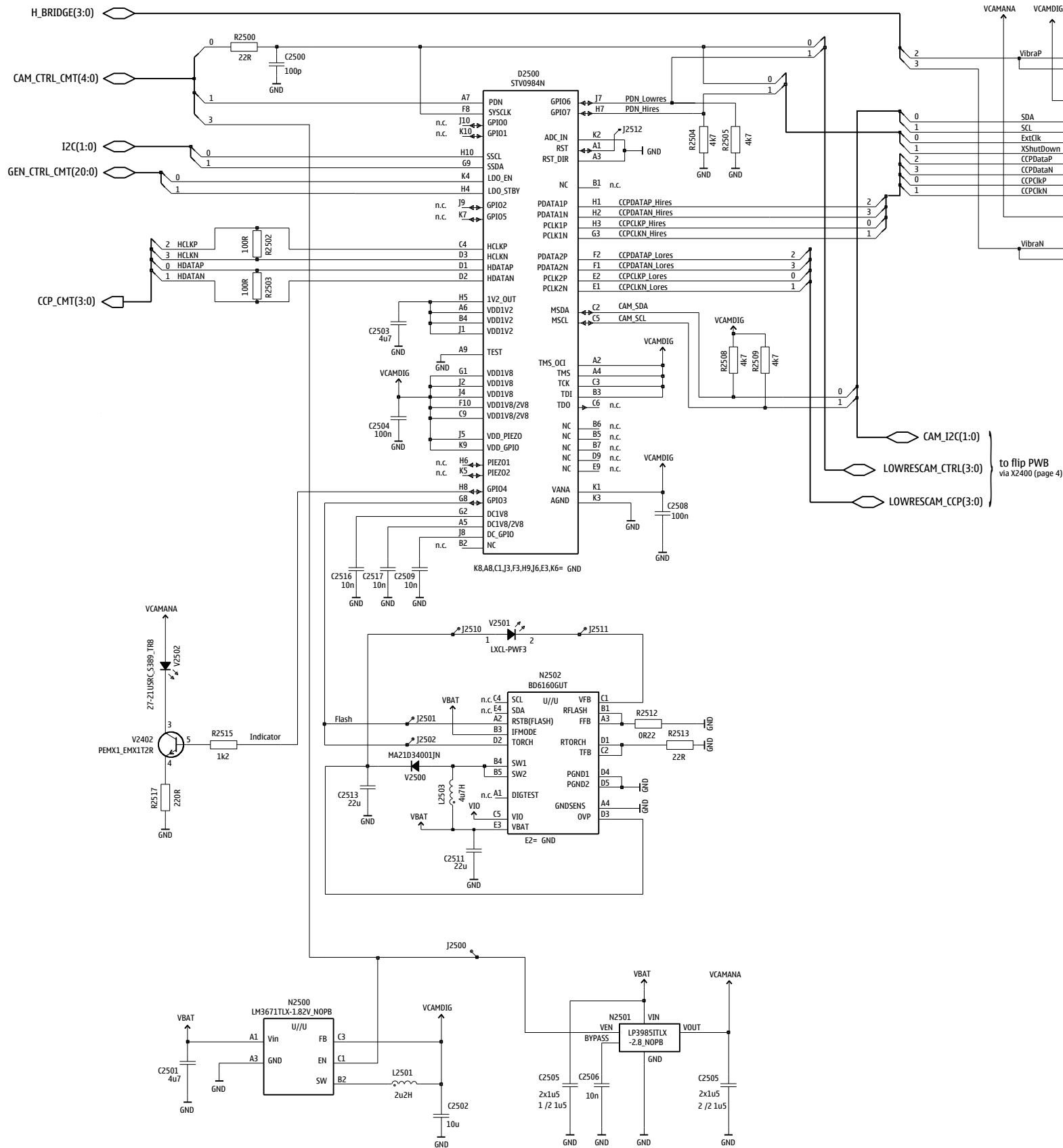

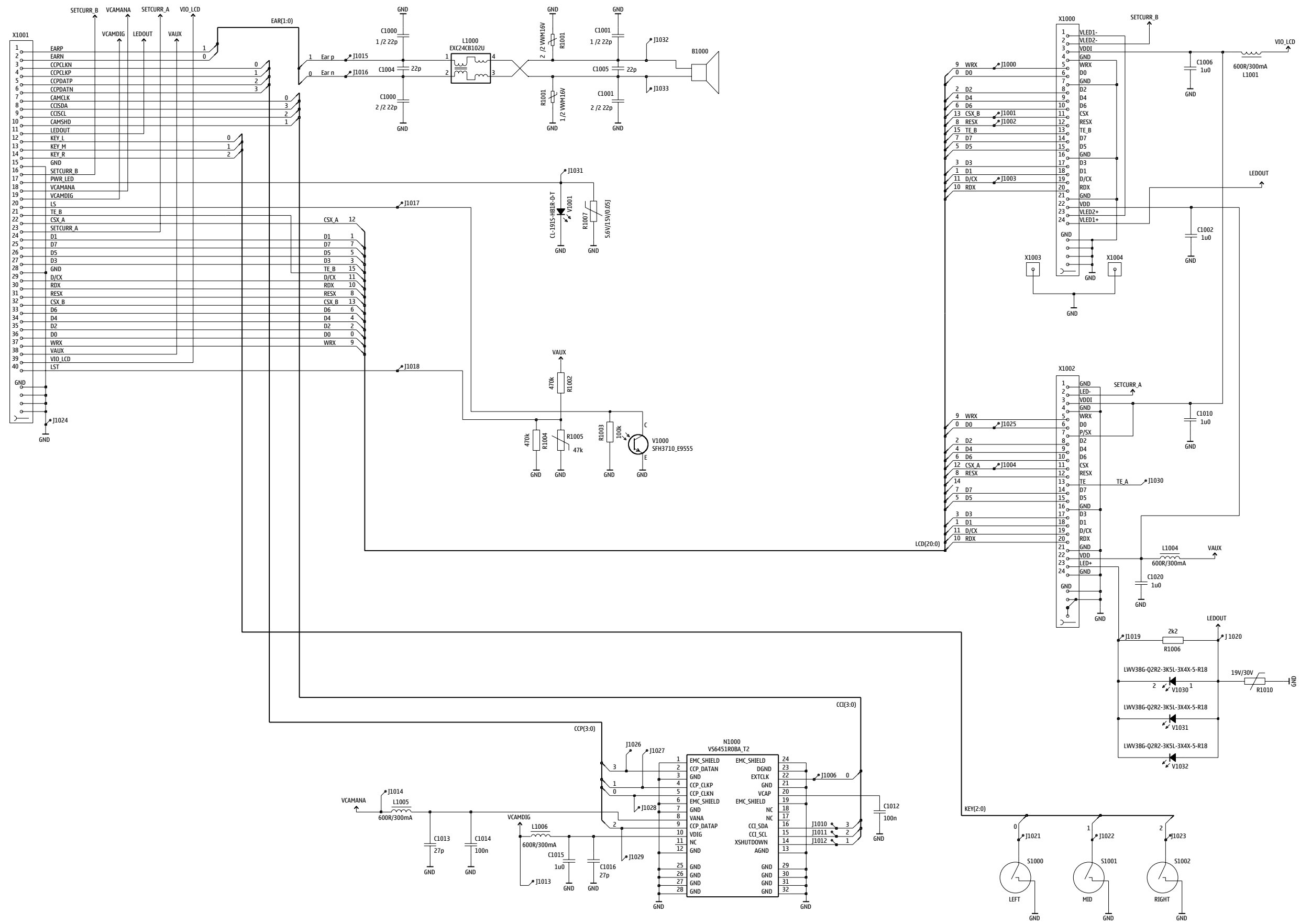

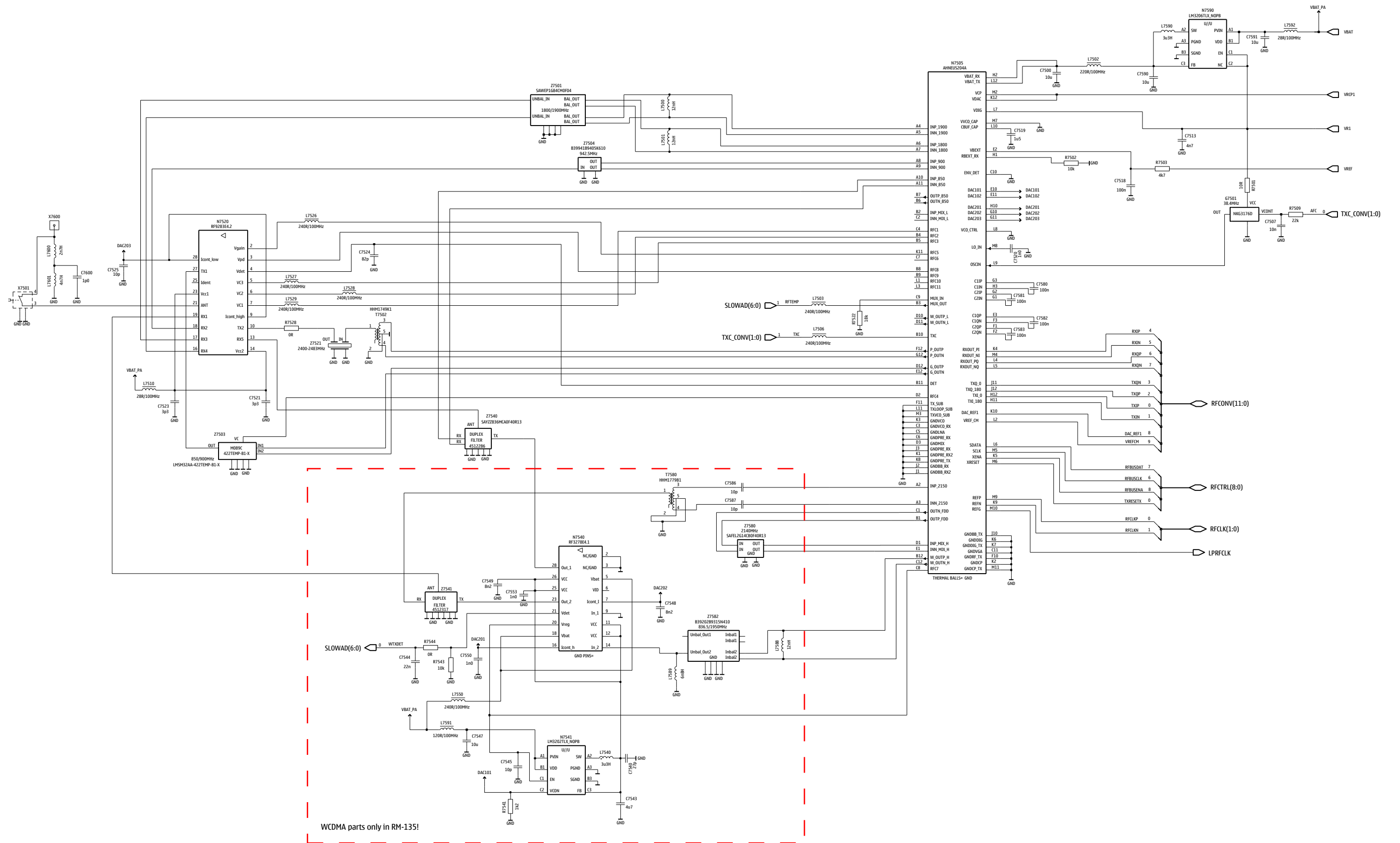

B	C2412	G9	C7548	Q9	J2510	C5	L7526	M8	R2515	C5	
B2200	E7	C2413	G9	C7549	P9	J2511	C6	L7527	N8	R2517	C5
C	C2414	G9	C7550	Q8	J2512	D6	L7528	N8	R2850	E6	
C2000	F2	C2415	G10	C7553	P9	J2700	I10	L7529	N8	R2851	E6
C2001	F2	C2500	E4	C7580	J8	J2701	I9	L7540	P8	R2852	G9
C2002	E3	C2501	F1	C7581	J8	J2702	I9	L7550	Q8	R2853	H9
C2003	F6	C2502	F1	C7582	J8	J2703	H9	L7588	L9	R3201	E5
C2005	E3	C2503	E6	C7583	K8	J2705	I10	L7589	L10	R3204	F4
C2006	E7	C2504	D4	C7586	L8	J2800	H9	L7590	M10	R6037	E7
C2007	E7	C2505	D5	C7587	L8	J2801	H9	L7591	Q8	R6038	C2
C2008	D7	C2506	D5	C7590	L10	J3100	H9	L7592	M9	R7501	K10
C2012	D3	C2508	D4	C7591	L9	J3101	H9	L7600	R8	R7502	K8
C2013	D3	C2509	E4	C7600	R8	J3102	H8	L7601	S8	R7503	L8
C2014	E6	C2511	F5	D	J3103	H9	N		R7509	K9	
C2015	E6	C2513	D5	D2500	D5	J3104	H8	N2000	F6	R7522	L9
C2016	D6	C2516	D4	D2800	F7	J3105	H8	N2001	D7	R7528	N10
C2017	F6	C2517	D6	D3000	F5	J3106	H8	N2200	F7	R7541	Q8
C2020	D4	C2700	I8	D6000	C3	J3107	H8	N2201	G2	R7543	P9
C2023	E3	C2800	E6	F	J3108	H8	N2300	G3	R7544	P8	
C2024	E3	C2801	E7	F2000	E2	J3109	H7	N2301	F2	S	
C2070	I8	C2802	E7	G	J3110	H9	N2302	F2	S2400	A8	
C2072	H4	C2803	E8	G2200	D8	J3111	H7	N2390	G5	S2401	D10
C2100	D7	C2804	E8	G7501	K10	J3112	H7	N2401	Q9	S2402	G10
C2101	D7	C2805	H7	J	J3113	H7	N2402	D9	S2403	O9	
C2102	D8	C2806	H8	J2000	C1	J3114	H8	N2500	F1	S2404	N9
C2105	G7	C2807	G9	J2001	A2	J3119	H8	N2501	D5	T	
C2106	G7	C2808	G9	J2002	C2	J3200	E5	N2502	D6	T7502	M10
C2107	G7	C2809	F9	J2003	C2	J3201	E4	N3200	E5	T7580	M8
C2108	B2	C2810	E6	J2005	C6	J3202	E5	N7505	K8	V	
C2109	B2	C2811	E7	J2060	H5	J3203	E5	N7520	N9	V2000	F2
C2200	E6	C2812	E7	J2070	G1	J3204	E5	N7540	P9	V2400	G1
C2201	E8	C2813	E8	J2072	G2	J3205	E5	N7541	P8	V2401	B4
C2202	E6	C2814	F9	J2073	G3	J6000	A4	N7590	L9	V2402	C5
C2205	E7	C2815	H8	J2101	T7	J6001	D3	R	V2500	D5	
C2211	G8	C2816	H6	J2102	S7	J6004	D2	R2001	F6	V2501	B6
C2213	E8	C2817	H6	J2200	E8	J6005	B3	R2004	E3	V2502	B5
C2215	F8	C2818	G9	J2201	F9	J6006	B3	R2005	E3	X	
C2216	E8	C3000	H4	J2202	G7	J6007	B3	R2006	D3	X2001	B3
C2217	F6	C3001	E4	J2203	E7	L	R2007	D3	X2002	B5	
C2220	G7	C3002	E6	J2204	G7	L2000	F2	R2011	C6	X2061	G6
C2222	G8	C3003	H4	J2205	G7	L2001	D3	R2016	D4	X2070	H2
C2225	G8	C3004	H5	J2206	H6	L2002	D3	R2071	H4	X2400	B4
C2226	E8	C3005	H5	J2207	H6	L2003	D2	R2072	H3	X2401	F9
C2227	F8	C3006	G3	J2208	E8	L2004	B6	R2100	S8	X2500	C5
C2228	F8	C3007	F3	J2209	H6	L2100	D7	R2101	S8	X2700	J8
C2229	G2	C3100	G6	J2210	F9	L2101	G7	R2200	F6	X3000	E2
C2230	H2	C3200	F5	J2211	E7	L2102	G7	R2201	E6	X7501	R8
C2231	G6	C3201	E5	J2212	E7	L2103	S7	R2300	G4	X7600	R9
C2232	F8	C3202	E5	J2213	G7	L2105	S7	R2302	F2	Z	
C2233	H2	C3204	E5	J2214	G7	L2201	G1	R2303	E2	Z2000	B6
C2234	D8	C6000	C2	J2215	G7	L2202	E8	R2402	Q9	Z2001	E3
C2301	G2	C6001	C2	J2217	E7	L2203	F8	R2404	F1	Z2401	A5
C2302	F3	C6002	C2	J2218	G2	L2204	F8	R2405	G1	Z2402	G9
C2303	G3	C6003	C4	J2219	H3	L2205	G6	R2408	C4	Z7501	M8
C2304	H2	C6004	B4	J2220	G9	L2206	F8	R2409	C4	Z7503	M9
C2305	F3	C7500	J9	J2221	G9	L2302	F3	R2410	C4	Z7504	L9
C2307	G3	C7507	K9	J2300	F6	L2304	F3	R2411	B5	Z7521	N10
C2312	F3	C7513	J8	J2301	F6	L2390	F5	R2412	C4	Z7540	O10
C2314	F3	C7518	L8	J2302	H3	L2400	F6	R2413	D9	Z7541	O9
C2315	E3	C7519	J8	J2305	H2	L2401	E9	R2414	D9	Z7580	L8
C2390	G5	C7520	J8	J2308	H3	L2402	D9	R2415	D9	Z7582	K10
C2391	G5	C7521	O8	J2309	F2	L2404	Q9	R2500	E4		
C2401	F6	C7523	O10	J2409	D8	L2501	E1	R2502	E7		
C2402	D9	C7524	M8	J2422	A3	L2503	E5	R2503	E7		
C2403	D9	C7525	M8	J2423	A3	L7500	L8	R2504	D4		
C2404	C9	C7540	P8	J2424	A3	L7501	L8	R2505	D4		
C2408	O10	C7543	P8	J2425	A3	L7502	L10	R2508	E4		
C2409	O10	C7544	Q8	J2500	F9	L7503	K8	R2509	E4		
C2410	Q9	C7545	Q8	J2501	D5	L7506	L9	R2512	D6		
C2411	G9	C7547	Q8	J2502	D6	L7510	O10	R2513	E6		

Parts marked blue only applies to RM-135!

