

# Service schematics

# Nokia X2-05

## RM-772

### IMPORTANT

This document is intended for use by authorized Nokia service centers only. Please use the document together with other documents such as the Service Manual and Service Bulletins.

### Version information

While every effort has been made to ensure that the document is accurate, some errors may exist. Please always check for the latest published version for this document.

If you find any errors in the document please send email to: [service.manuals@nokia.com](mailto:service.manuals@nokia.com)

- 1.0 First approved version.
- 2.0 B2150, R2162, R2163 component code corrected.  
VSS\_VIB connection added.



### Contents

Front page	1
X-GOLD, Power, HS USB, Camera, SIM	2
X-GOLD, Memory, MMC, Audio	3
X-GOLD, Display, Keymat	4
X-GOLD, RF part, RF power, BTH	5
Component finder top	6
Component finder bottom	7

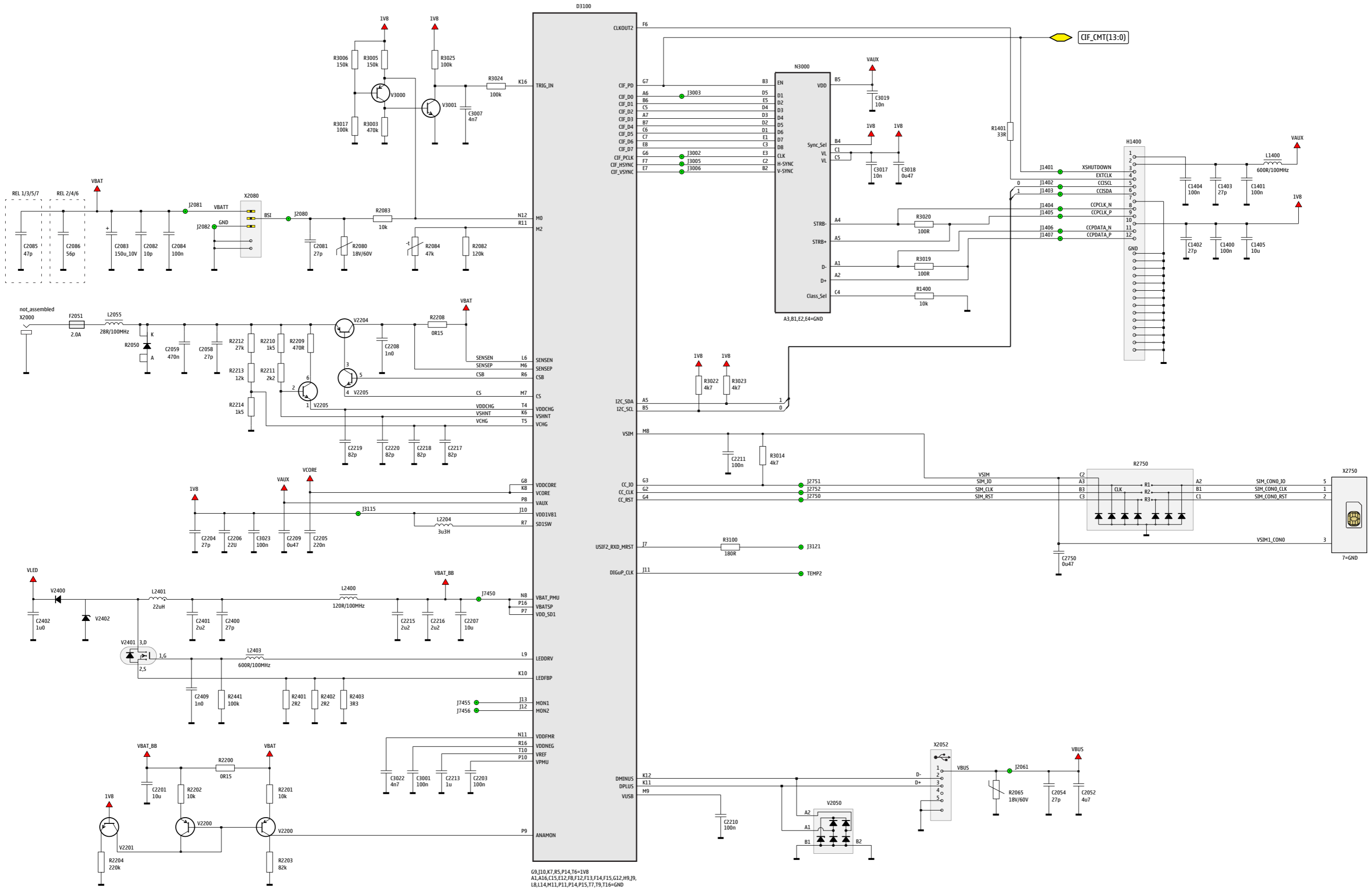

G9,J10,K7,A5,P14,T6=1V8  
 A1,A16,C15,E12,F8,F12,F13,F14,F15,G12,H9,J9,  
 L8,L14,M11,P11,P14,P15,T7,T9,T16=GND

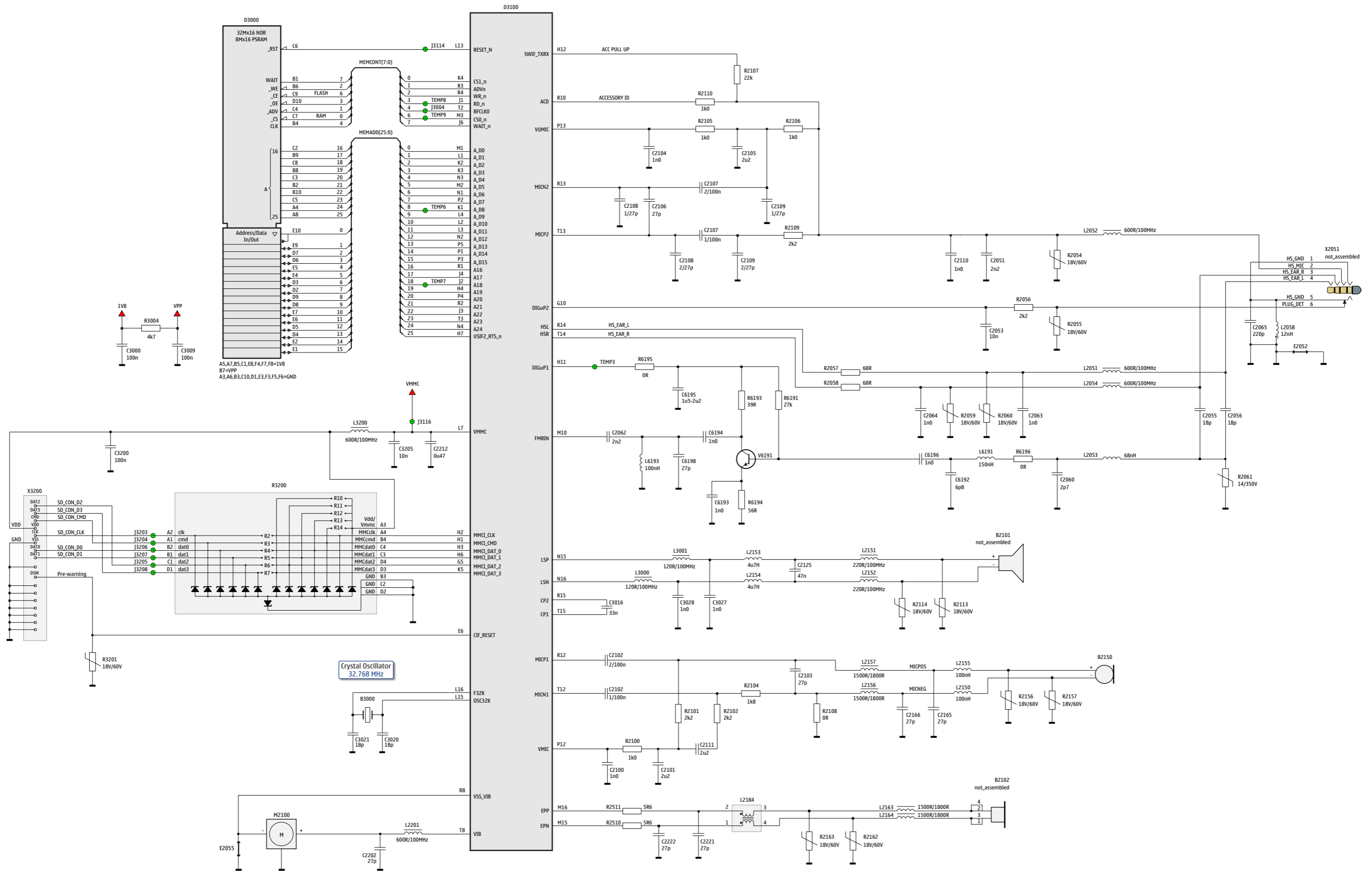

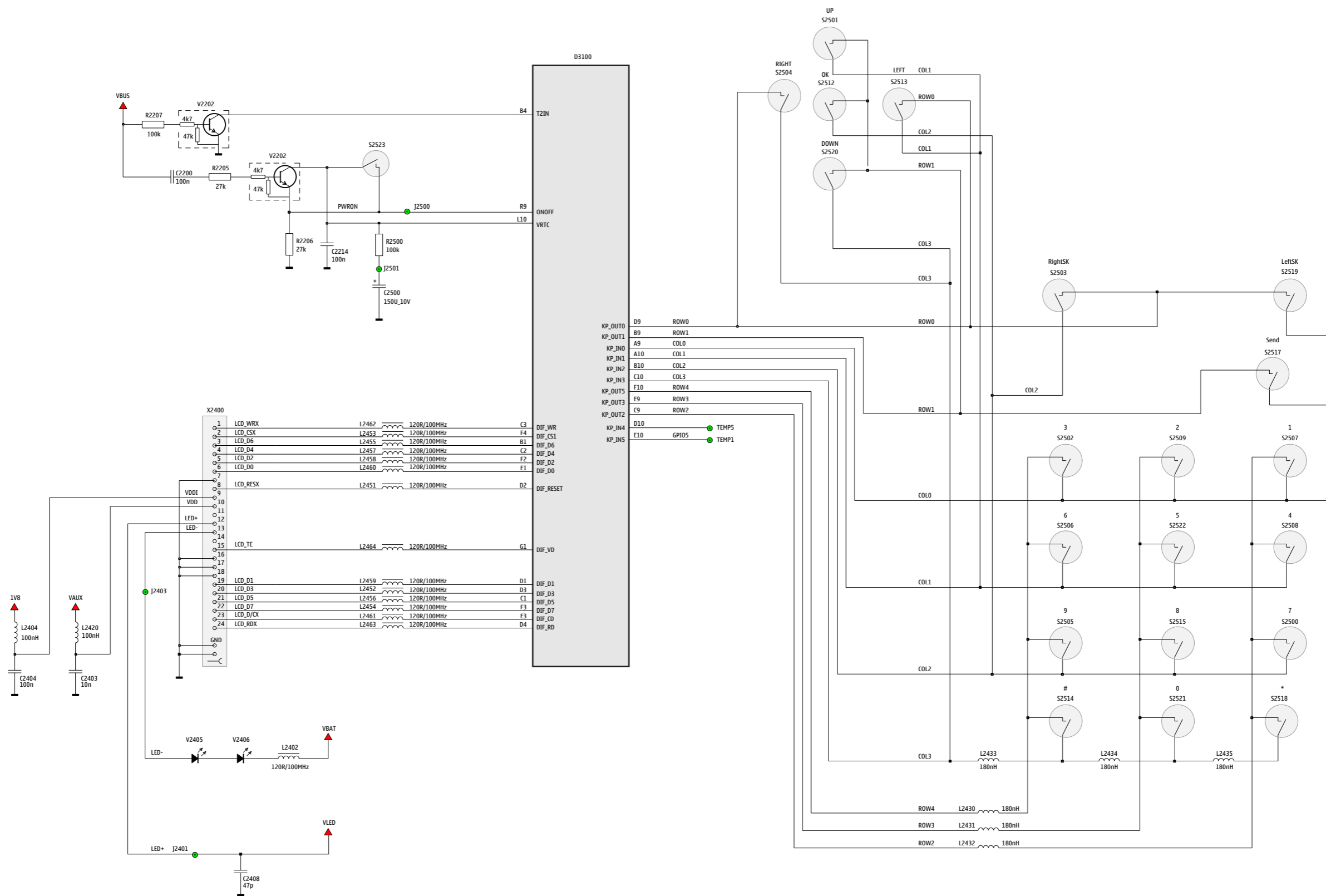

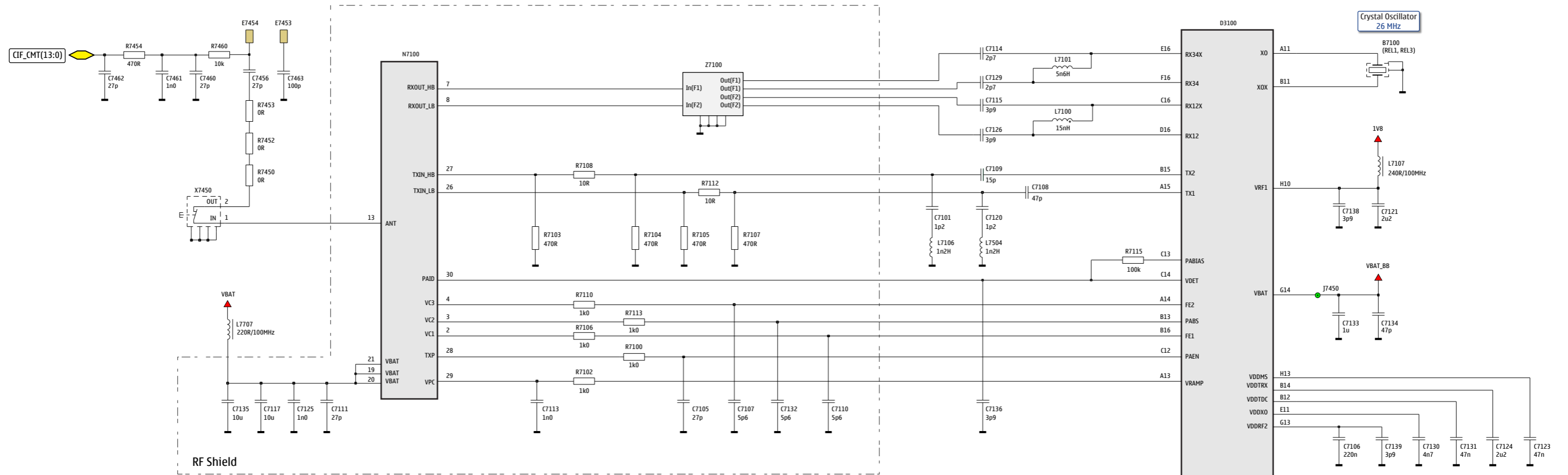

RF Shield

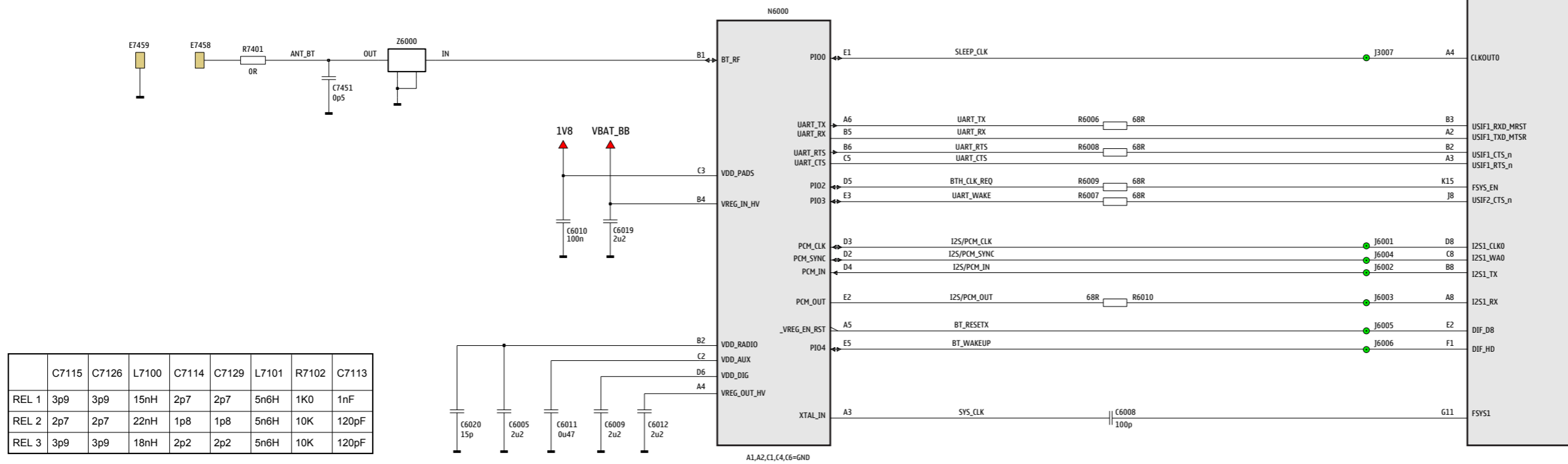

	C7115	C7126	L7100	C7114	C7129	L7101	R7102	C7113
REL 1	3p9	3p9	15nH	2p7	2p7	5n6H	1K0	1nF
REL 2	2p7	2p7	22nH	1p8	1p8	5n6H	10K	120pF
REL 3	3p9	3p9	18nH	2p2	2p2	5n6H	10K	120pF

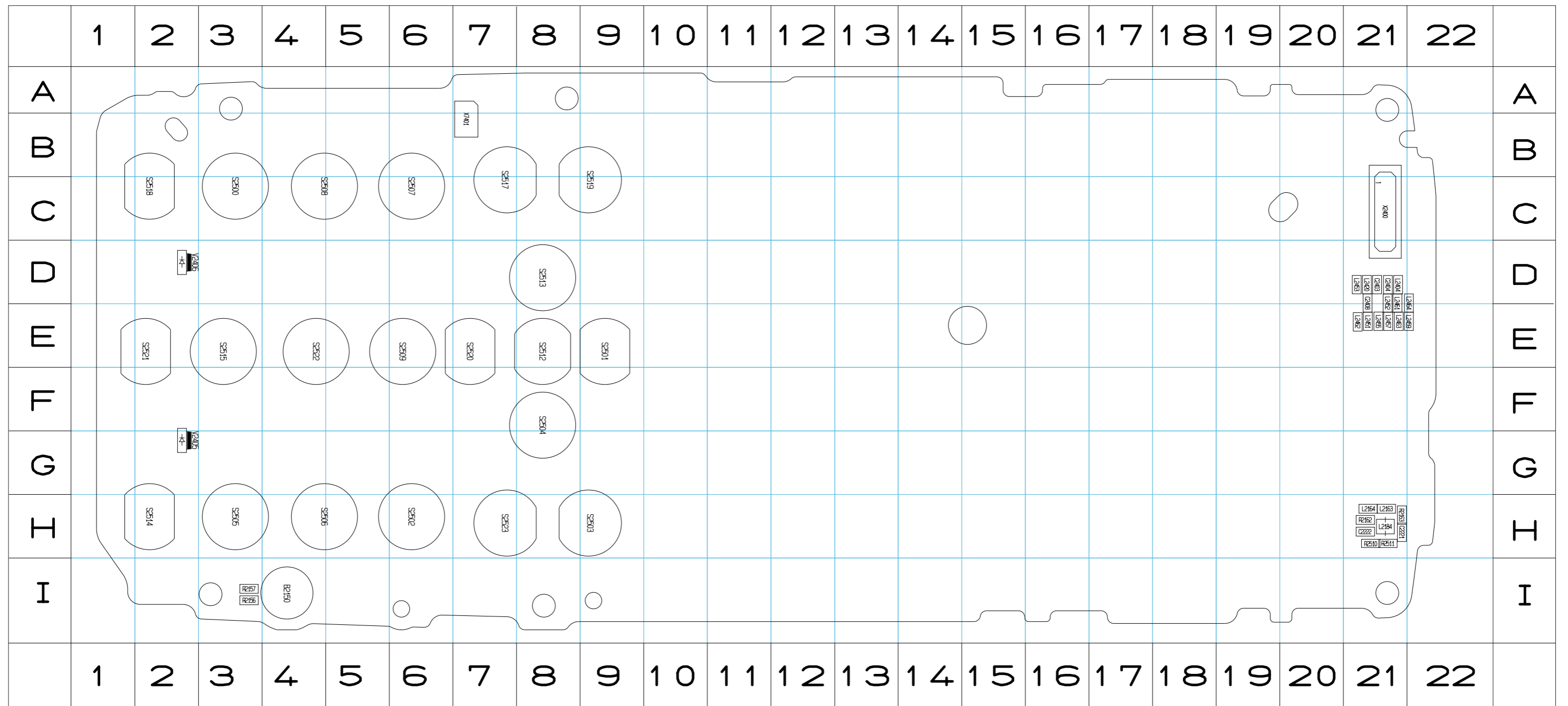

<b>B</b>	C2404	D21	L2404	D21	L2457	E21	<b>R</b>	R2511	H21	X7401	B7
B2150	I4	C2408	D21	L2420	D21	L2459	E22	R2156	I3	<b>V</b>	
<b>C</b>	<b>L</b>		L2451	E21	L2461	D21	R2157	I3	V2405	G2	
C2221	H21	L2163	H21	L2452	D21	L2462	E21	R2162	H21	V2406	D2
C2222	H21	L2164	H21	L2453	D21	L2463	E21	R2163	H21	<b>X</b>	
C2403	D21	L2184	H21	L2455	E21	L2464	D22	R2510	H21	X2400	C21



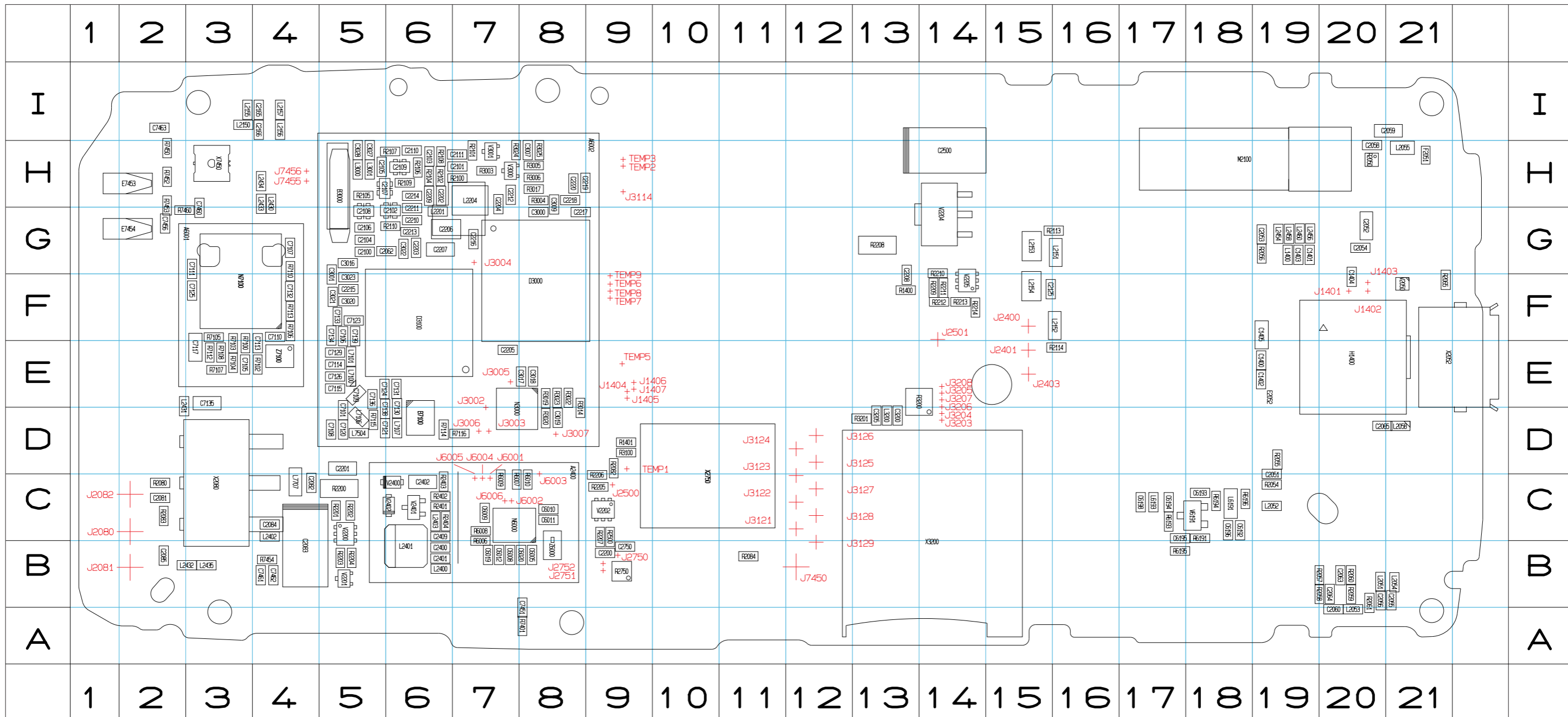

<b>A</b>	C2051	D19	C2082	C4	C2110	H6	C2209	H6	C2402	C6	C3022	G6	C6192	C18	C7113	E4	C7133	F5	D3100	F6	L2055	H21	L2402	C4	L3200	D13	N7100	F3	R2080	C2	R2113	G16	R2212	F14	R3017	H8	R6010	C8	R7110	G4	V2200	C5	X2750	C10	
A2400	C7	C2052	G20	C2083	B4	C2111	H7	C2210	G6	C2409	C6	C3023	F5	C6193	C18	C7114	E5	C7134	F5	<b>E</b>	L2058	D21	L2403	C6	L6191	C18	<b>R</b>	R2082	D9	R2114	E16	R2213	F14	R3019	E8	R6191	C18	R7112	E3	V2201	B5	X3200	C14		
A6001	F3	C2053	G19	C2084	C4	C2125	F15	C2211	G6	C2500	H14	C3027	H5	C6194	C17	C7115	E5	C7135	E3	E7453	H2	L2150	I3	L2430	H4	L6193	C17	R1400	F13	R2083	C2	R2200	C5	R2214	F14	R3020	D8	R6193	C17	R7113	F4	V2202	C9	X7450	H3
A6002	F7	C2054	G20	C2085	B2	C2165	I4	C2212	H7	C2750	B9	C3028	H5	C6195	C17	C7117	E3	C7136	E5	E7454	G2	L2151	G16	L2431	E2	L7100	E5	R1401	D9	R2084	B11	R2201	C5	R2401	C6	R3022	E8	R6194	C18	R7114	D6	V2204	G14	<b>Z</b>	
<b>B</b>	C2055	B21	C2100	G5	C2166	I4	C2213	G6	C3000	G8	C3200	D13	C6196	C18	C7120	D5	C7138	D5	<b>F</b>	L2152	F16	L2432	B3	L7101	E5	R2050	H20	R2100	H7	R2202	C5	R2402	C6	R3023	E8	R6195	B17	R7115	D5	V2205	F14	Z6000	B8		
B3000	H5	C2056	B20	C2101	H7	C2200	B9	C2214	H6	C3001	F5	C3205	D13	C6198	C17	C7121	D5	C7139	F5	F2051	H21	L2153	G15	L2433	H4	L7106	D5	R2054	C19	R2101	H7	R2203	B5	R2403	C6	R3024	H7	R6196	C18	R7116	D7	V2400	C6	Z7100	E4
B7100	D6	C2058	H20	C2102	G6	C2201	D5	C2215	F5	C3007	H8	C6005	B8	C7101	D5	C7123	F5	C7451	A8	<b>H</b>	L2154	F15	L2434	H4	L7107	D6	R2055	D19	R2102	H6		B5	R2404	C6	R3025	H8	R7100	E3	R7401	A8	V2401	C6			
<b>C</b>	C2059	I21	C2103	H6	C2202	H6	C2216	G7	C3009	H8	C6008	B7	C7105	E3	C7124	E5	C7456	G2	H1400	E20	L2155	I3	L2435	B3	L7504	D5	R2056	G19	R2104	H6	R2205	C9	R2500	C9	R3100	D9	R7102	E4	R7450	H2	V2402	C6			
C1400	E19	C2060	A20	C2104	G5	C2203	G6	C2217	G8	C3016	G5	C6009	C7	C7106	F5	C7125	F3	C7460	G3	<b>L</b>	L2156	I4	L2454	G19	L7707	C4	R2057	B20	R2105	H5	R2206	C9	R2750	B9	R3200	E14	R7103	E3	R7452	H2	V3000	H7			
C1401	G19	C2062	G6	C2105	H5	C2204	H7	C2218	H8	C3017	E8	C6010	C8	C7107	G4	C7126	E5	C7461	B4	L1400	G19	L2157	I4	L2456	G19	<b>M</b>	R2058	B20	R2106	H6	R2207	C9	R3003	H7	R3201	D13	R7104	E3	R7453	H2	V3001	H7			
C1402	E19	C2063	B20	C2106	G5	C2205	E7	C2219	H8	C3018	E8	C6011	C8	C7108	D5	C7129	E5	C7462	B4	L2051	B20	L2201	G6	L2458	G19	M2100	H18	R2059	B20	R2107	H6	R2208	G13	R3004	H8	R6006	B7	R7105	F3	R7454	B4	V6191	C18		
C1403	G19	C2064	B20	C2107	H5	C2206	G6	C2220	H8	C3019	D8	C6012	B7	C7109	E5	C7130	D6	C7463	I2	L2052	C19	L2204	H7	L2460	G19	<b>N</b>	R2060	B20	R2108	H6	R2209	F14	R3005	H8	R6007	C7	R7106	F4	R7460	G2	<b>X</b>				
C1404	F20	C2065	D20	C2108	G5	C2207	G6	C2400	B6	C3020	F5	C6019	B7	C7110	F4	C7131	E6	<b>D</b>	L2053	A20	L2400	B6	L3000	H5	N3000	D7	R2061	B20	R2109	H6	R2210	G14	R3006	H8	R6008	C7	R7107	E3	<b>V</b>	X2052	E22				
C1405	F19	C2081	C2	C2109	H6	C2208	F13	C2401	B6	C3021	F5	C6020	B8	C7111	G3	C7132	F4	D3000	F8	L2054	B21	L2401	B6	L3001	H5	N6000	C7	R2065	F21	R2110	G6	R2211	F14	R3014	D8	R6009	C7	R7108	E3	V2050	F21	X2080	C3		

[www.s-manuals.com](http://www.s-manuals.com)