

# Standard Instrumentation Packages for ORBIT Pneumatic Actuators

TECHNOLOGY

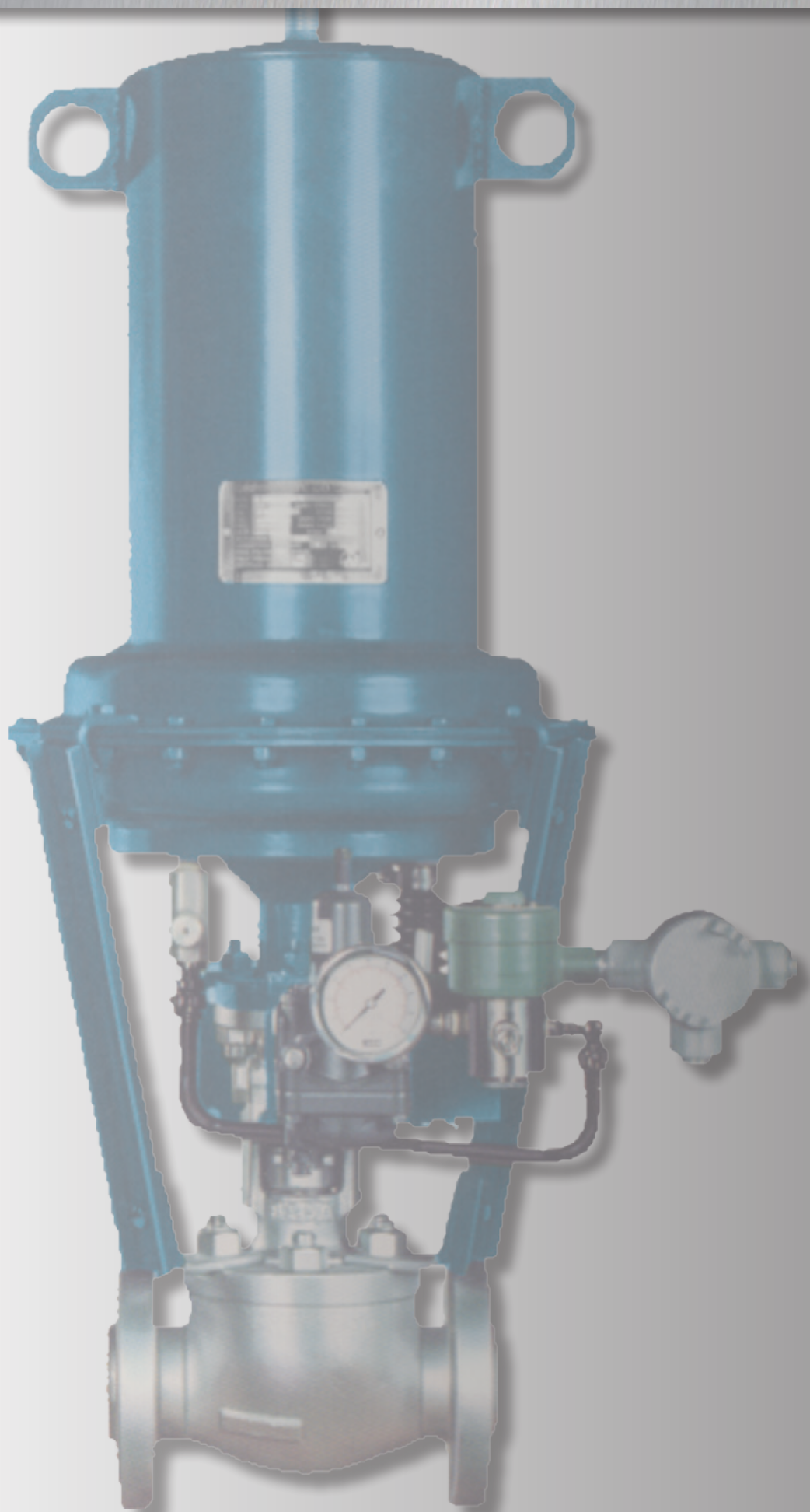



# Table of Contents

## STANDARD INSTRUMENTATION PACKAGES FOR ORBIT PNEUMATIC ACTUATORS

Introduction.....	4
Quality Assurance .....	5
Ordering Information and Unit Responsibility.....	6

### Systems for Spring-Close Actuators

<b>Fail Close on Loss of.....</b>	<b>Figure No. ....</b>	<b>Page</b>
Pneumatic Signal .....	A-12100 .....	7
Electric Signal .....	A-12101 .....	8
Pneumatic Signal or Supply Pressure .....	A-12102 .....	9*
Electric Signal or Supply Pressure .....	A-12103 .....	9
Electric Signal or Supply Pressure .....	A-12842 .....	10
Pneumatic Signal, Manual Reset to Open.....	A-13156 .....	11*
Electric Signal, Manual Reset to Open .....	A-12338 .....	11
Pneumatic Signal or Supply Pressure, Manual Reset to Open.....	A-14741 .....	12
Electric Signal or Supply Pressure, Manual Reset to Open .....	A-12291 .....	13
High-Pressure Shutdown System.....	A-12755 .....	14
Low-Pressure Shutdown System.....	A-13526 .....	15
High-Low Pressure Shutdown System .....	A-12385 .....	15*

### Systems for Spring-Open Actuators

<b>Fail Open on Loss of .....</b>	<b>Figure No. ....</b>	<b>Page</b>
Pneumatic Signal .....	A-12306 .....	16*
Electric Signal .....	A-12682 .....	16
Pneumatic Signal or Supply Pressure .....	A-12309 .....	17*
Electric Signal or Supply Pressure .....	A-12455 .....	17
Electric Signal or Supply Pressure .....	A-12864 .....	10*

\* Refer to this page for a similar system. Exact system is not shown.

### Systems for Double-acting Actuators

<b>Fail Close on Loss of.....</b>	<b>Figure No. ....</b>	<b>Page</b>
Pneumatic Signal .....	A-12104 .....	18
Electric Signal.....	A-12105 .....	18*
Pneumatic Signal, Actuator with Manual Mechanism .....	A-12106 .....	19*
Electric Signal, Actuator with Manual Mechanism .....	A-12107 .....	19
Pneumatic Signal or Supply Pressure.....	A-12108 .....	20
Pneumatic Signal or Supply Pressure, Actuator with Manual Mechanism .....	A-12109 .....	20*
Electric Signal or Supply Pressure.....	A-12276 .....	21
Electric Signal or Supply Pressure, Actuator with Manual Mechanism .....	A-12299 .....	22
Pneumatic Signal or Supply Pressure, Manual Reset to Open .....	A-13860 .....	23
Electric Signal or Supply Pressure, Manual Reset to Open .....	A-12719 .....	24

### Systems for Double-acting Actuators

<b>Fail Close on Loss of.....</b>	<b>Figure No. ....</b>	<b>Page</b>
Pneumatic Signal .....	A-12741 .....	18*
Electric Signal.....	A-13666 .....	18*
Pneumatic Signal, Actuator with Manual Mechanism .....	A-12978 .....	19*
Electric Signal, Actuator with Manual Mechanism .....	A-12413 .....	19*
Pneumatic Signal or Supply Pressure.....	A-12677 .....	20*
Pneumatic Signal or Supply Pressure, Actuator with Manual Mechanism .....	A-12702 .....	20*
Electric Signal or Supply Pressure.....	A-12345 .....	25
Electric Signal or Supply Pressure, Actuator with Manual Mechanism .....	A-12680 .....	25*

\* Refer to this page for a similar system. Exact system is not shown.

## Systems for Double-Acting Actuators

<b>Fail in Last Position on Loss of .....</b>	<b>Figure No. ....</b>	<b>Page</b>
Pneumatic Signal .....	A-12110 .....	26 *
Electric Signal.....	A-12111 .....	26
Pneumatic Signal, Actuator with Manual Mechanism .....	A-12112 .....	26 *
Electric Signal, Actuator with Manual Mechanism .....	A-12113 .....	26 *
Pneumatic Signal or Supply Pressure.....	A-12114 .....	27 *
Electric Signal or Supply Pressure.....	A-12115 .....	27
Pneumatic Signal or Supply Pressure, Actuator with Manual Mechanism .....	A-12116 .....	29 *
Electric Signal or Supply Pressure, Actuator with Manual Mechanism .....	A-12117 .....	29
Electric Signal, Single-Exhaust Solenoid .....	A-13289 .....	26 *
Electric Signal, Single-Exhaust Solenoid, Actuator with Manual Mechanism.....	A-12814 .....	26 *
Electric Signal or Supply Pressure, Single-Exhaust Solenoid .....	A-14983 .....	31
Electric Signal or Supply Pressure, Single-Exhaust Solenoid, Actuator with Manual Mechanism .....	A-12946 .....	31 *
Override Operation .....		33
Information Required to Order Pneumatic Systems Other Than Standard Packages.....		33
Adaptation of CX Micro Switch to ORBIT Diaphragm and Pistons Actuators .....		34
Proximity Type Limit Switches for ORBIT Valves and Actuators .....		35
CAMSERV Aftermarket Services for Valves and Actuation.....		36

\* Refer to this page for a similar system. Exact system is not shown.



## INTRODUCTION

### **Cameron's ORBIT Brand can Provide you With Perfectly Matched Packages Which Include Valve, Actuator and Instrumentation**

#### **Unique Design Makes Automation Easier**

Our ORBIT® valves are ideal for automation by the very nature of their operating principle. Many automated valves remain open or closed for extended periods of time. This and other environmental and process conditions can cause higher breakaway torque in valves with friction between their sealing surfaces.

The mechanical camming action of an ORBIT valve retracts the core from its seat as it opens. The core is then rotated to the open position without scraping the seat. This reduces the need for the high torque actuators found on many other valves, which scrape their seating surfaces together during opening and closing. By eliminating the opening and closing friction, ORBIT valves can provide economical, low-pressure operators and still be assured of sufficient thrust to open and close the valve.

#### **ORBIT Actuators are Specially Designed for Use Exclusively on ORBIT Valves**

ORBIT actuators provide reliable, trouble-free, on-off operation and are especially suitable for simple or extensive instrumentation.

#### **ORBIT Valves Offers a Wide Variety of Piston and Diaphragm Actuators**

ORBIT valves can be equipped with perfectly matched ORBIT linear actuators. Many capabilities can be added to the basic double-acting actuator. Models are available with spring return to open or close. Manual override mechanisms also are available.

#### **A Full Range of Instrumentation Capabilities**

A variety of instrumentation capabilities can be provided to meet your system's needs. Many common systems are available as economical standard packages. Pneumatically or electrically activated systems are available. You can order our standard systems or custom systems designed to your specifications. Standard packages include combinations for spring-return or double-acting actuators, with signals to open or close and provisions for fail open, fail close, or fail in last position on loss of signal or pneumatic supply.

#### **Design Assistance**

The ORBIT brand can provide design assistance and recommend proven systems, or you may prefer to specify your own design and have our factory mount and test it for you. Most ORBIT valves can easily be automated in the field at a later date.



## QUALITY ASSURANCE

Cameron's Little Rock, Ark., US, manufacturing facility has quality programs that are ISO 9001 registered.

### Specifications and Compliances

- API 6D
- ISO 9001:2008
- PED 97/23/EC
- ATEX Directive 94/9/EC
- GOST
- GOST-R Certificate and RTN Permit
- ISO 15848-1 (Fugitive Emission Type Testing)
- Shell GSI SPE 77/300 TAT Qualified and TAMAP Two-Star Rating
- ASME B16.34

Cameron's manufacturing philosophy and the standard 36-month warranty ensures that the design, materials and workmanship of all ORBIT products result in years of dependable operation.

Certifications for hydrostatic test results and material properties are available on request.



Gas testing and certification to the latest industry standards is performed by independent inspectors.



The Little Rock facility has undergone a new layout reorganization and CAPEX investment in state-of-the-art equipment.



Every ORBIT valve built is individually pressure tested to meet or exceed industry standards.

## ORDERING INFORMATION

This brochure illustrates some of the commonly requested ORBIT instrumentation packages available from Cameron. If you find that one or more of these packages are suitable for your needs, they can be ordered by the assembly package number (preceded by the letter "A") found under the assembly package title. We will custom design instrumentation packages based on your specific requirements. You may list your requirements or simply mark your changes on the most appropriate schematic drawing found in this brochure. If you have special needs or have developed your own automated systems, Cameron will work with you to produce custom packages for a wide variety of control systems. Cameron has engineers and technicians skilled in instrumentation and valve automation. They are ready to work to design and build the proper system for you. Contact a Cameron representative for more information.

## UNIT RESPONSIBILITY

Purchasing the entire package from Cameron is simple, convenient and economical. Only one purchase order needs to be written, reducing paperwork, time and other potential problems such as multiple shipments and customs clearances. You are assured all components work together. Assembly is done by full-time automation specialists, with the unit fully tested before leaving the factory, and the package is generally less expensive than purchasing individual components separately.





## Systems for Spring-Close Actuators

### PNEUMATIC SIGNAL TO OPEN, FAIL CLOSE ON LOSS OF SIGNAL – A-12100\*

The pneumatic signal activates the three-way, normally closed, pneumatic-operated, spring-return valve, allowing supply pressure to move the actuator and valve to the open position. The opening speed is controlled by adjusting the flow control.

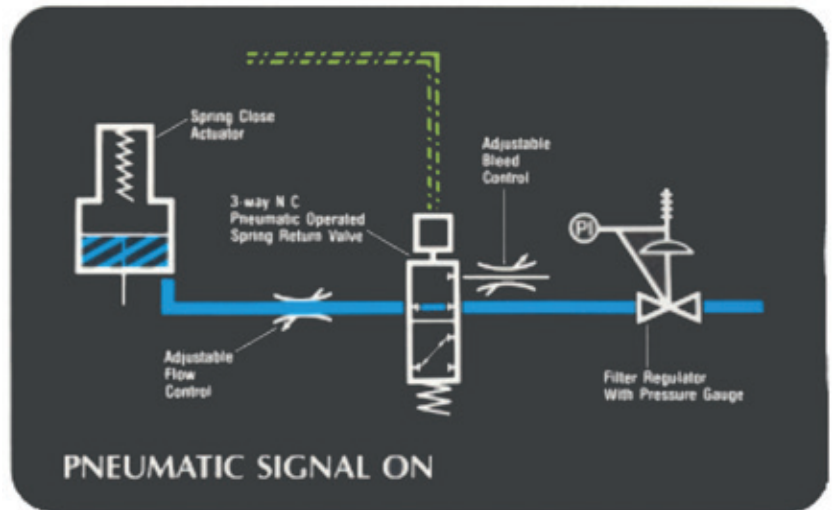

Loss of the pneumatic signal returns the three-way valve to the normally closed position, allowing the actuator and valve to spring close. The closing speed is controlled by adjusting the bleed control. Set pressure of the filter regulator is in accordance with the operating pressure indicated on the actuator's nameplate.

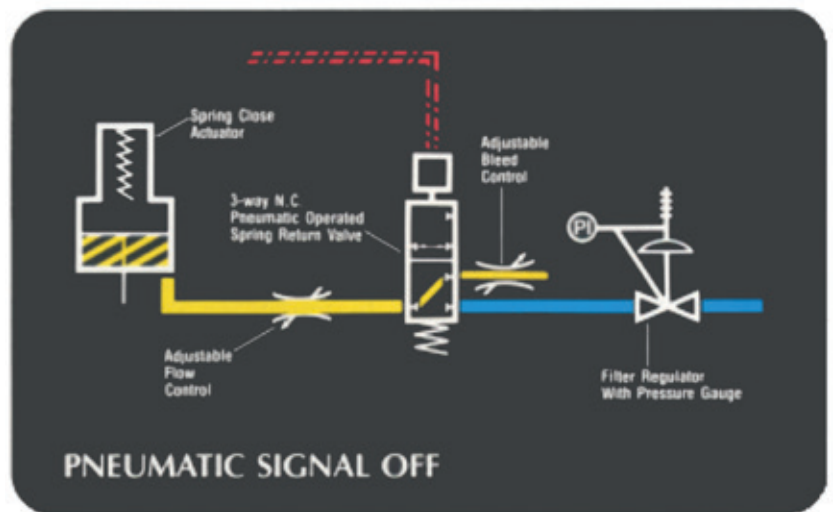

\* Fail action also will occur if the supply pressure is completely lost (drops to 0 psig).



## Systems for Spring-Close Actuators

### ELECTRIC SIGNAL TO OPEN, FAIL CLOSE ON LOSS OF SIGNAL – A-12101\*

The electric signal activates the three-way, normally closed, solenoid-operated, spring-return valve, allowing supply pressure to move the actuator and valve to the open position. The opening speed is controlled by adjusting the flow control.

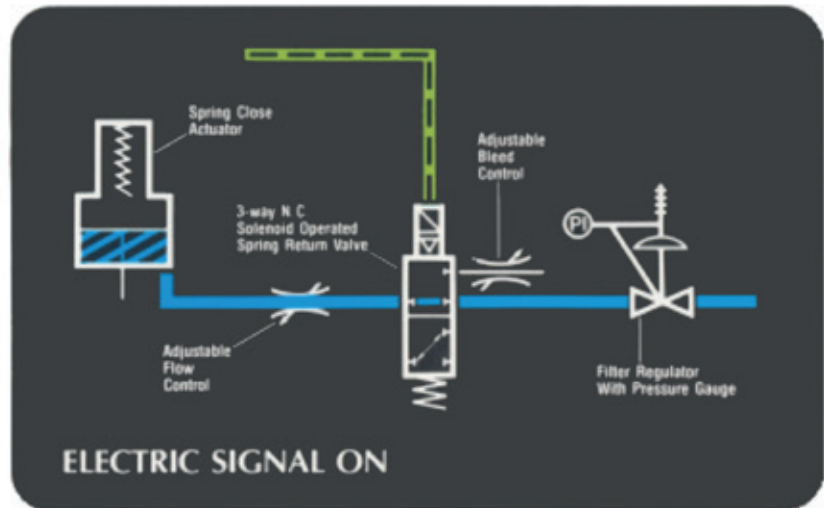

Loss of the electric signal returns the three-way valve to the normally closed position, allowing the actuator and valve to spring close. The closing speed is controlled by adjusting the bleed control. Set pressure of the filter regulator is in accordance with the operating pressure indicated on the actuator's nameplate.

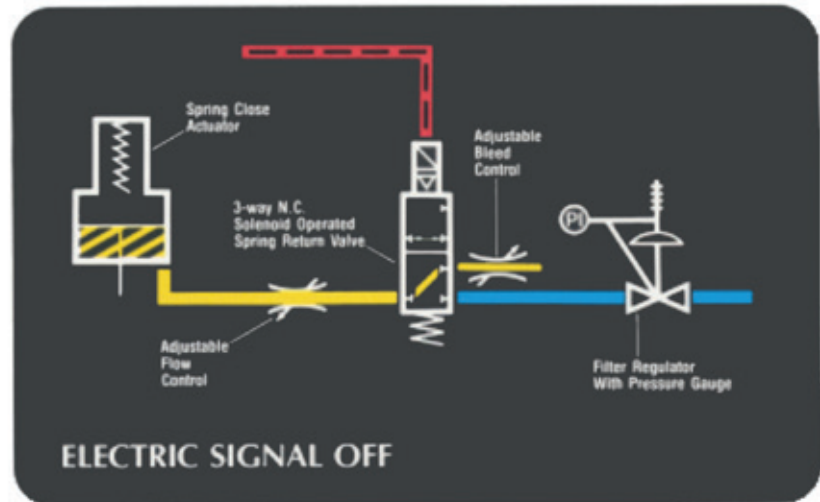

\* Fail action will also occur if the supply pressure is completely lost (drops to 0 psig).  
A-12842 is required if a small-ported solenoid valve (less than 1/8") is used. See page 12.

	SIGNAL ON		AIR PRESSURE
	SIGNAL OFF		AIR EXHAUST

## ELECTRIC SIGNAL TO OPEN, FAIL CLOSE ON LOSS OF SIGNAL OR SUPPLY PRESSURE – A-12103\*

The electric signal activates the three-way, normally closed, solenoid-operated, spring-return valve, allowing supply pressure to move the actuator and valve to the open position. The opening speed is controlled by adjusting the flow control.

Loss of the electric signal returns the three-way valve to the normally closed position, allowing the actuator and valve to spring close. The closing speed is controlled by adjusting the bleed control. Set pressure of the filter regulator is in accordance with the operating pressure indicated on the actuator's nameplate.

To allow the actuator to fail close on loss of supply pressure, a three-way switching valve is set 10 psi (0.7 bar) below the maximum operating pressure. When pressure at port "D" is above the set point, ports "A" and "B" are connected and port "C" is blocked. When pressure at port "D" falls below the set point, ports "A" and "C" are connected and port "B" is blocked, exhausting pressure, allowing the actuator and valve to spring close.

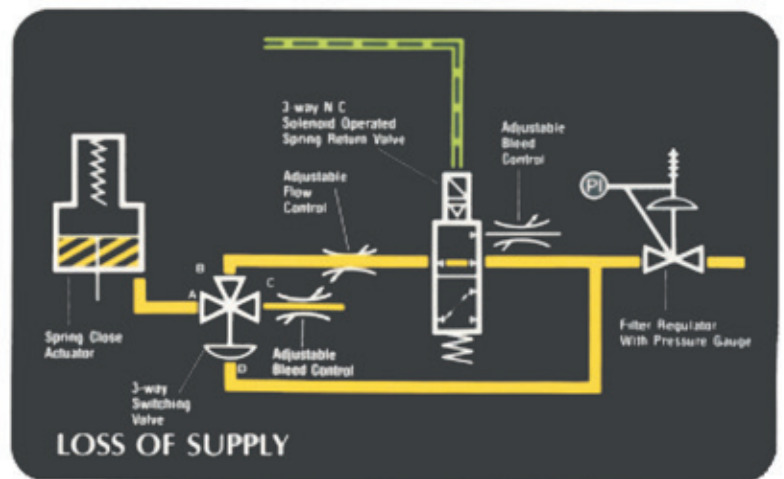
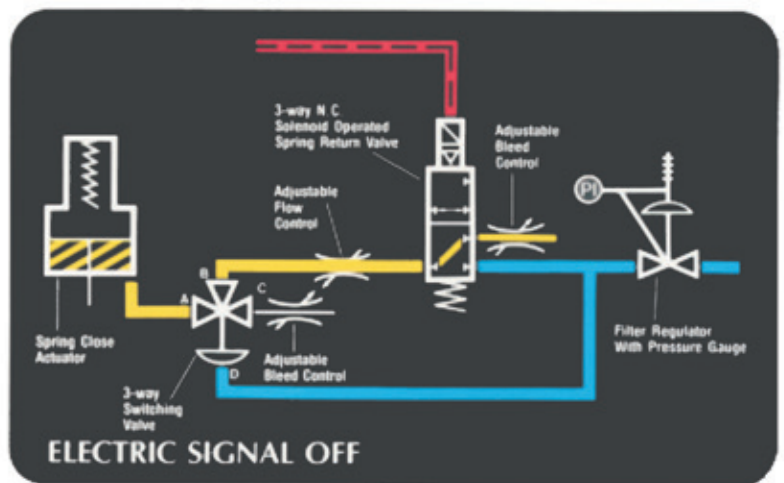
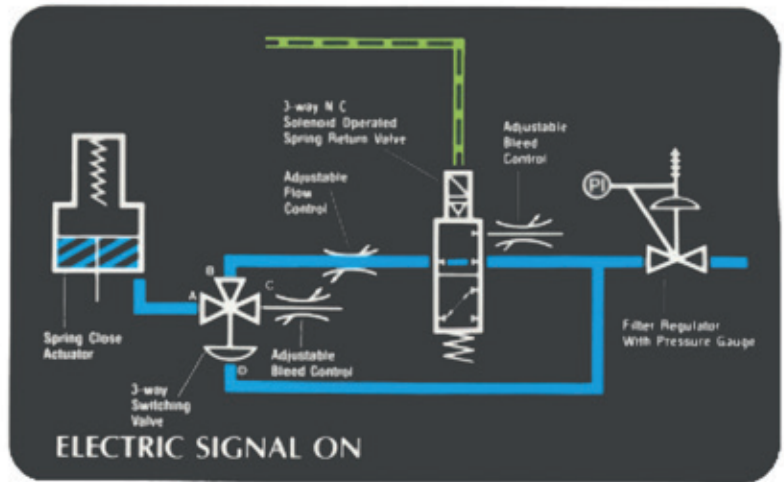

\* For the pneumatic signal, order A-12102. A-12842 is required if a small-ported solenoid valve (less than 1/8") is used. See page 12.

- SIGNAL ON
- AIR PRESSURE
- SIGNAL OFF
- AIR EXHAUST

## ELECTRIC SIGNAL TO OPEN, FAIL CLOSE ON LOSS OF SIGNAL OR SUPPLY PRESSURE – A-12842\*

The electric signal activates the three-way, normally closed, direct-acting solenoid valve, allowing supply pressure to switch the three-way switching valve. This action connects ports "A" and "B", allowing the supply pressure to move the actuator to the open position. The opening speed is controlled by adjusting the flow control.

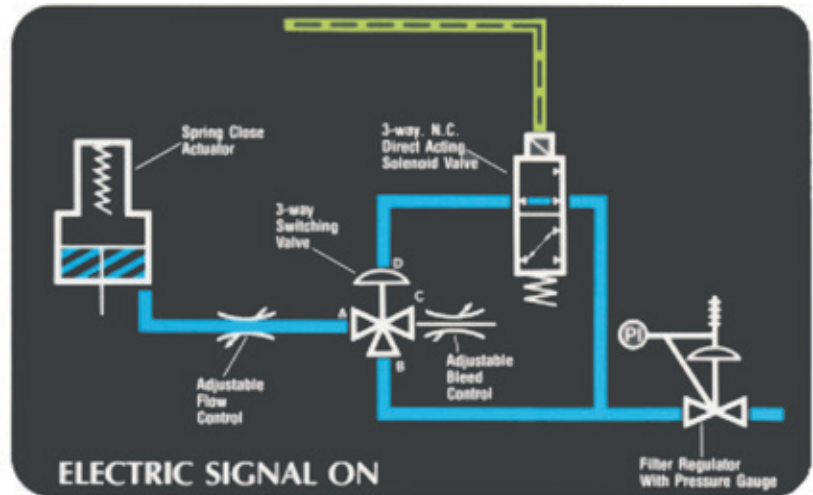

Loss of the electric signal moves the three-way, normally closed, direct-acting solenoid valve to the normally closed position. This action vents the supply pressure from the three-way switching valve and connects ports "A" and "C", while blocking port "B". The supply pressure is then vented from the actuator, allowing it to spring close. The closing speed is controlled by adjusting the bleed control. Set pressure of the filter regulator is in accordance with the operating pressure indicated on the actuator's nameplate.

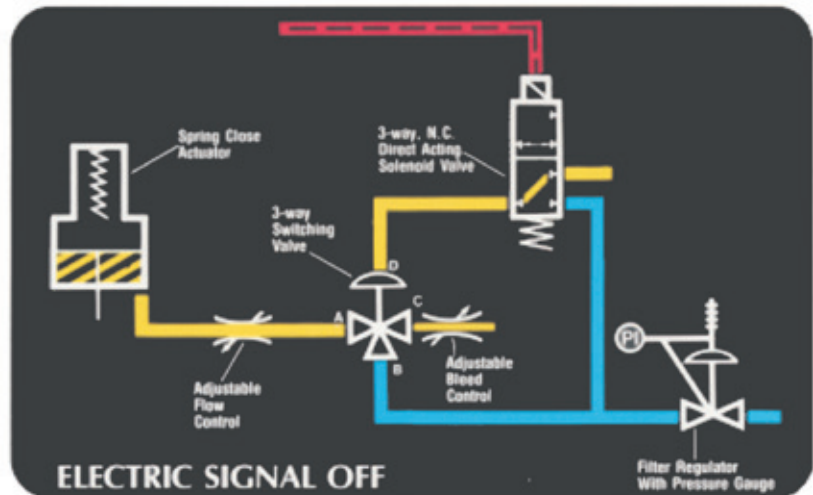

To allow the actuator to fail close on loss of supply pressure, a three-way switching valve is set 10 psi (0.7 bar) below the maximum operating pressure. When pressure at port "D" is above the set point, ports "A" and "B" are connected and port "C" is blocked, allowing the actuator and valve to open. When pressure at port "D" falls below set points, ports "A" and "C" are connected and port "B" is blocked, allowing the actuator and valve to spring close.

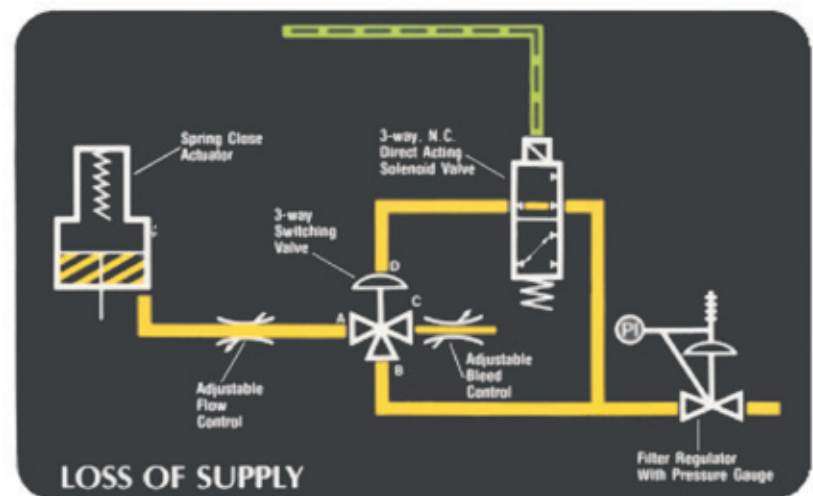

\* For a fail-open system (same controls on the spring-open actuator), order A-12864. A-12842 (fail close) or A-12864 (fail open) is required if a small-ported solenoid valve (less than 1/8") is used.

- SIGNAL ON
- AIR PRESSURE
- SIGNAL OFF
- AIR EXHAUST



## ELECTRIC SIGNAL TO OPEN, FAIL CLOSE ON LOSS OF SIGNAL, MANUAL RESET TO OPEN – A-12338\*

The ORBIT valve is opened by manually moving the lever of the three-way solenoid valve to the latched position. If a no voltage-release type reset is furnished, the solenoid must be energized before this can be done. The opening speed is controlled by adjusting the flow control.

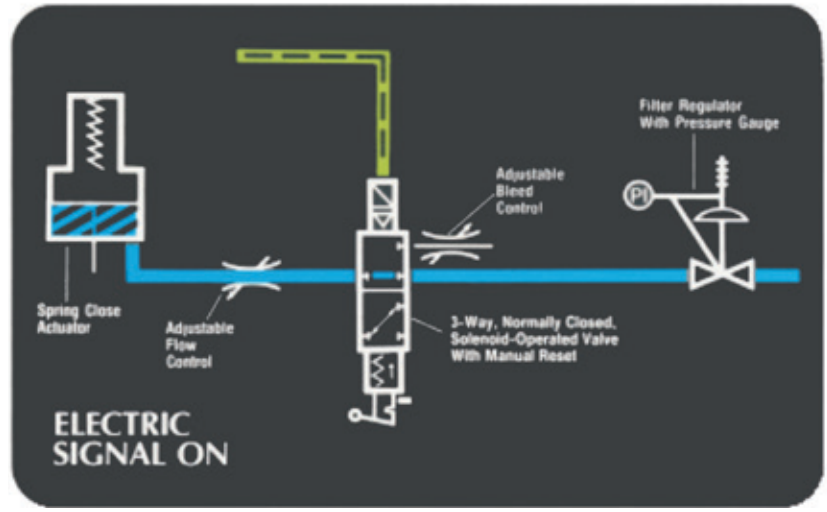

The electric signal activates the three-way, normally closed, solenoid-operated, spring-return valve, allowing supply pressure to move the actuator and valve to the open position. The opening speed is controlled by adjusting the flow control.

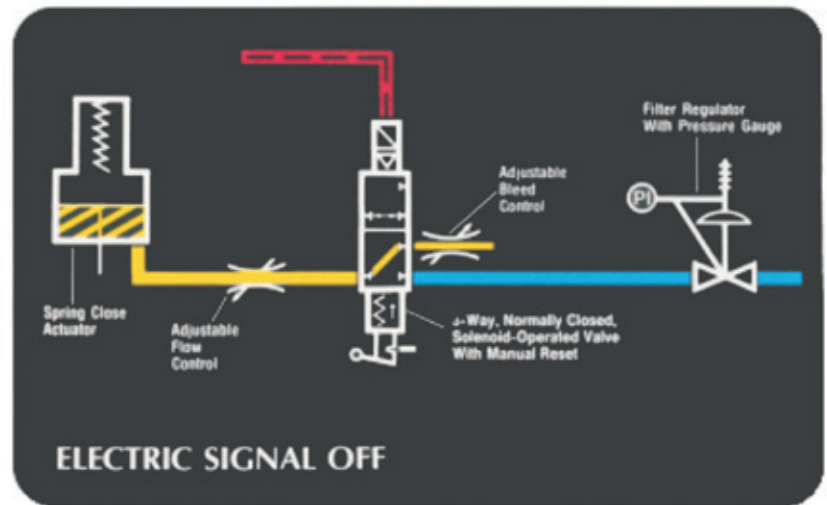

\* For a pneumatic signal, order A-12102. A-12842 is required if a small-ported solenoid valve (less than 1/8") is used. See page 12.

- SIGNAL ON      ■ AIR PRESSURE
- SIGNAL OFF    ■ AIR EXHAUST

## PNEUMATIC SIGNAL TO OPEN, FAIL CLOSE ON LOSS OF SIGNAL OR SUPPLY PRESSURE, MANUAL RESET TO OPEN – A-14741

The ORBIT valve is opened by manually moving the lever of the three-way pilot valve to the latched position, and it is kept open with a pneumatic signal. The opening speed is controlled by adjusting the flow control valve.

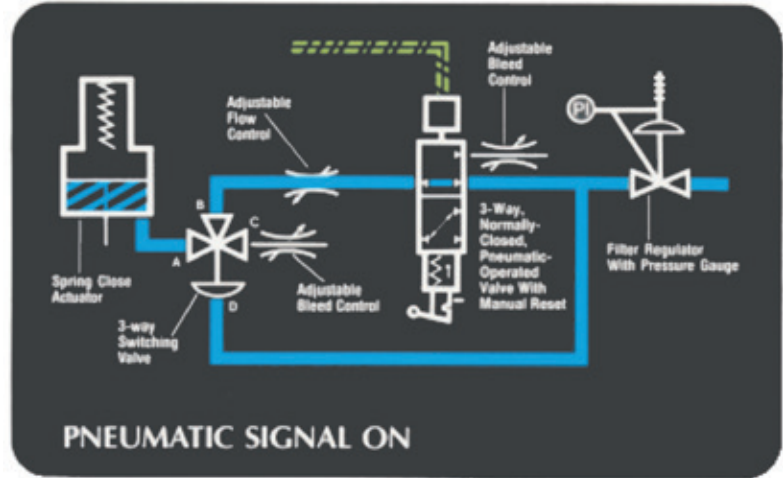

Loss of pneumatic signal returns the three-way pilot valve to the normally closed position, allowing the actuator to spring close. The ORBIT valve cannot be reopened until the three-way pilot valve is manually reset. The closing speed is controlled by adjusting the bleed control in the exhaust port of the three-way valve. Set point of the filter regulator is the operating pressure stamped on the actuator's nameplate.

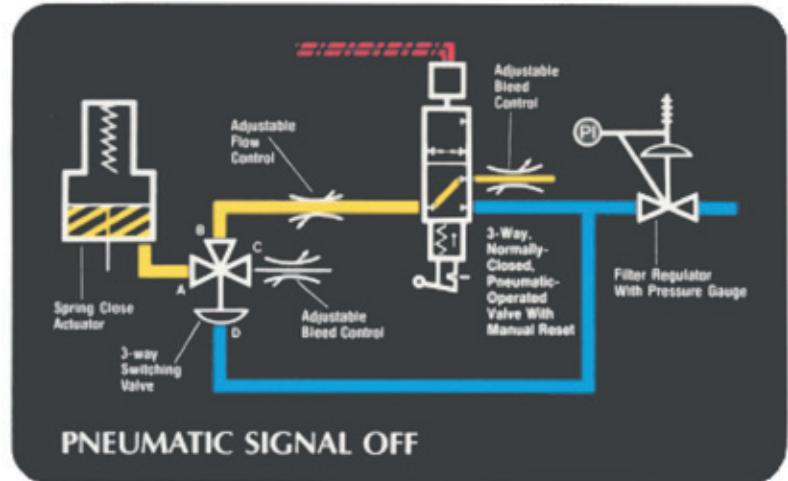

To allow the actuator to fail close on loss of supply pressure, a three-way switching valve is set about 10 psi (0.7 bar) below the maximum operating pressure. When pressure at port "D" is above the set point, ports "A" and "B" are connected and port "C" is blocked. When pressure at port "D" falls below the set point, ports "A" and "C" are connected and port "B" is blocked, exhausting pressure, allowing the actuator and valve to spring close.

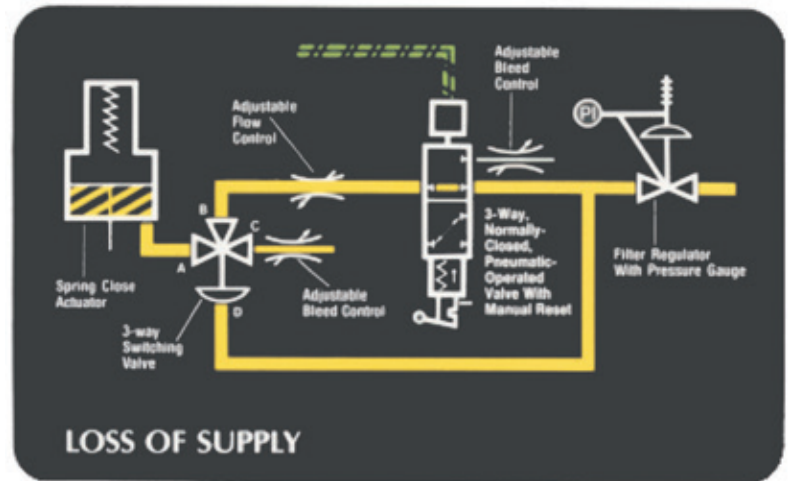

- SIGNAL ON
- AIR PRESSURE
- SIGNAL OFF
- AIR EXHAUST

## ELECTRIC SIGNAL TO OPEN, FAIL CLOSE ON LOSS OF SIGNAL OR SUPPLY PRESSURE, MANUAL RESET TO OPEN – A-12291

The ORBIT valve is opened by manually moving the lever of the three-way solenoid valve to the latched position. If a no voltage-release type reset is furnished, the solenoid must be energized before this can be done. The opening speed is controlled by adjusting the flow control valve.

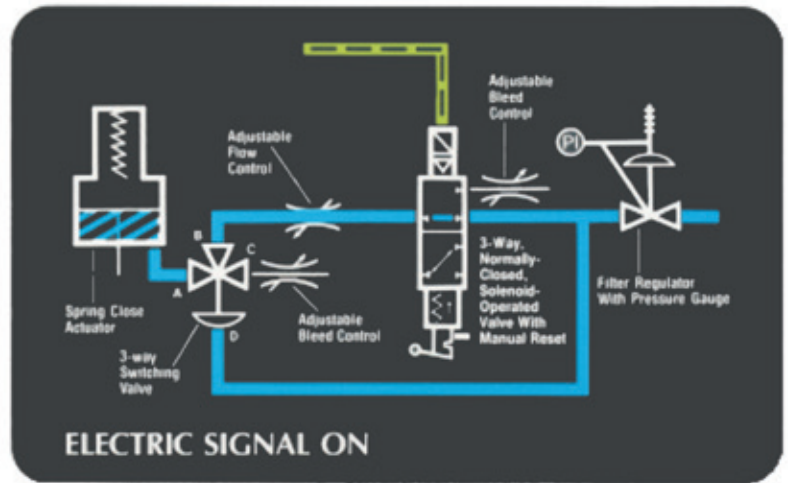

Loss of electric signal returns the three-way solenoid valve to the normally closed position, allowing the actuator to spring close. The ORBIT valve cannot be reopened until the three-way solenoid valve is manually reset. The closing speed is controlled by adjusting the bleed control in the exhaust port of the three-way pilot valve. Set point of the filter regulator is the operating pressure stamped on the actuator's nameplate.

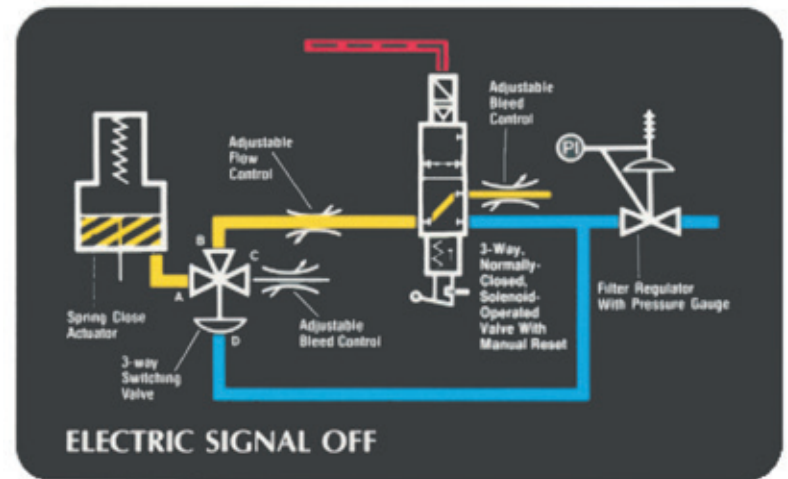

To allow the actuator to fail close on loss of supply pressure, a three-way switching valve is set about 10 psi (0.7 bar) below the maximum operating pressure. When pressure at port "D" is above the set point, ports "A" and "B" are connected and port "C" is blocked. When pressure at port "D" falls below the set point, ports "A" and "C" are connected and port "B" is blocked, exhausting pressure, allowing the actuator and valve to spring close.

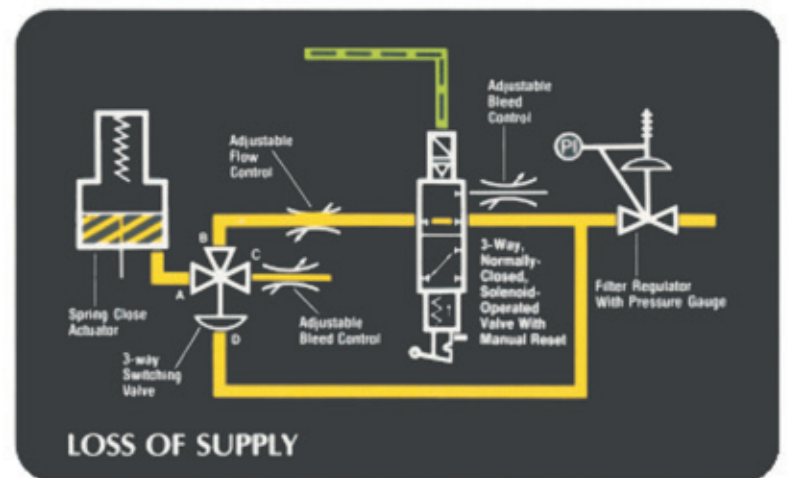

- SIGNAL ON
- AIR PRESSURE
- SIGNAL OFF
- AIR EXHAUST

## HIGH-PRESSURE SHUTDOWN SYSTEM – A-12755

When the line pressure is below the set point of the pressure sensor, the supply pressure is directed through the pressure sensor to the pilot of the three-way valve. By pulling the palm button on the three-way valve, the supply pressure is directed to the bottom of the actuator to open the ORBIT valve.

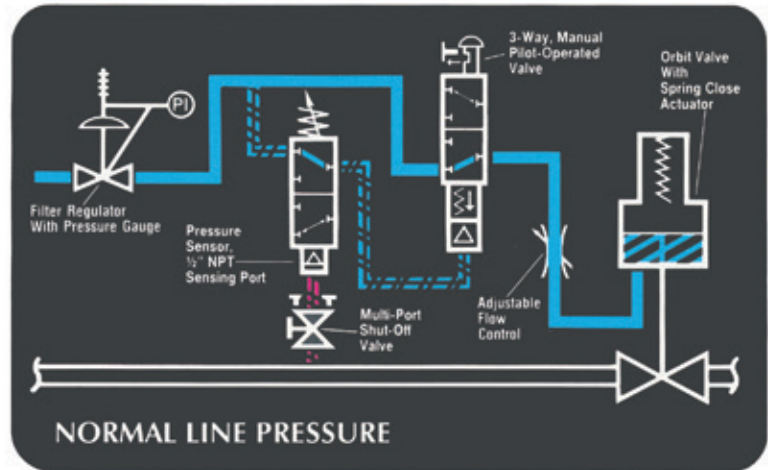

When the line pressure rises above the set point of the pressure sensor, the supply pressure is blocked and the pressure is vented from the pilot of the three-way valve. The three-way valve spring returns, which blocks supply pressure, vents the pressure from the actuator and allows the actuator to spring close. The closing speed is controlled by adjusting the flow control.

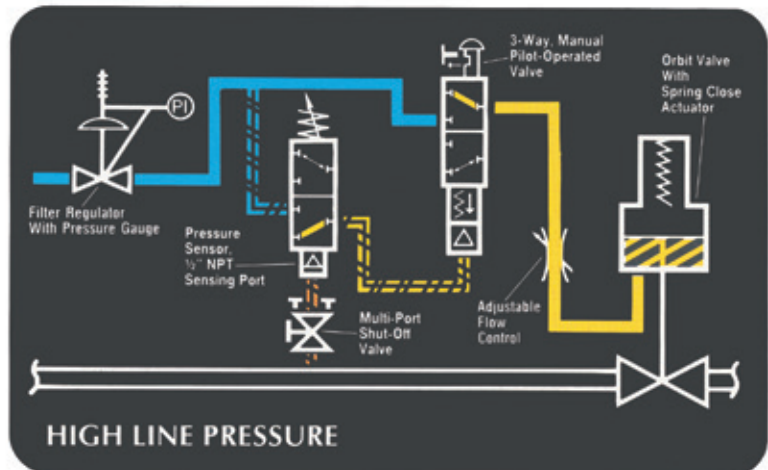

The optional multi-port, shut-off valve may be used to isolate the line pressure and provide a means of testing or readjusting the pressure sensor while in service or to serve as a gauge valve. Pressure sensors and multi-port, shut-off valves require field installation, and lines denoted by are to be provided and piped by the customer. Set point of the filter regulator is the operating pressure stamped on the actuator's nameplate.

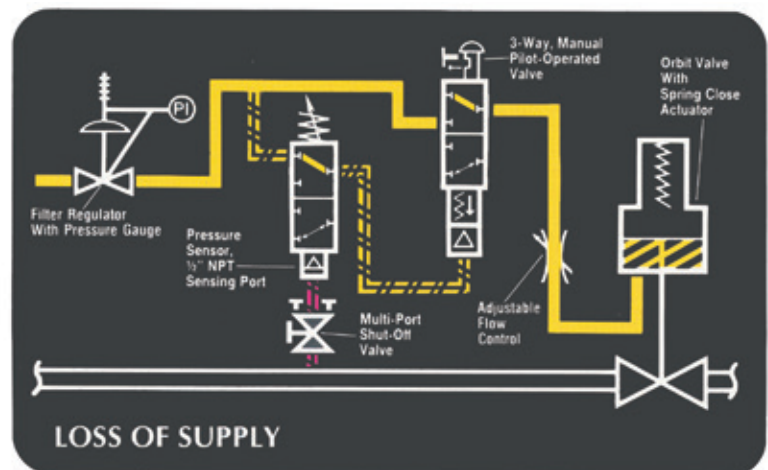

- NORMAL LINE PRESSURE
- AIR PRESSURE
- HIGH LINE PRESSURE
- AIR EXHAUST



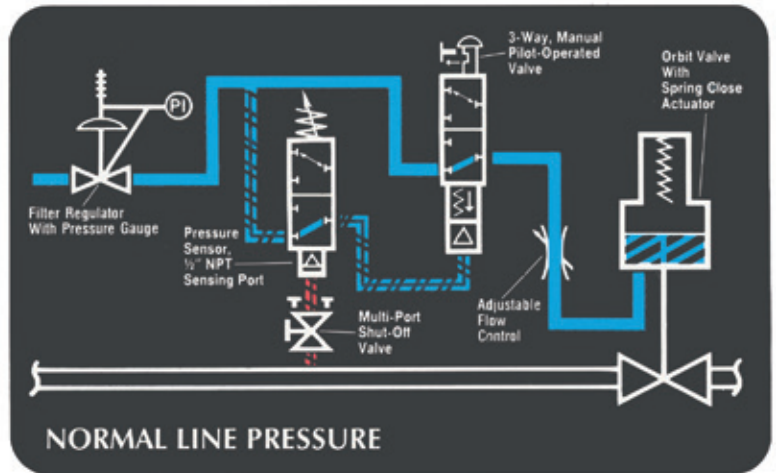

## LOW-PRESSURE SHUTDOWN SYSTEM – A-13526\*

When the line pressure is above the set point of the pressure sensor, the supply pressure is directed through the pressure sensor to the pilot of the three-way valve. By pulling the palm button on the three-way valve, the supply pressure is directed to the bottom of the actuator to open the ORBIT valve.

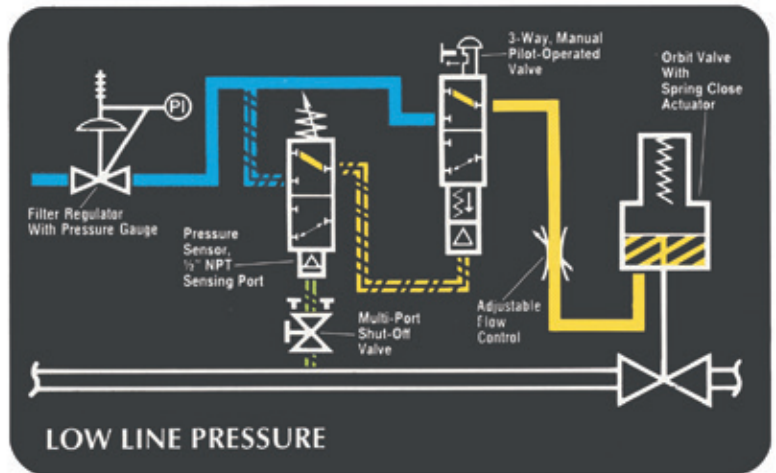

When line pressure falls below the set point of the pressure sensor, the supply pressure is blocked and the pressure is vented from the pilot of the three-way valve. The three-way valve spring returns, which blocks supply and pressure, vents the pressure from the actuator and allows the actuator to spring close. The closing speed is controlled by adjusting the flow control.



The optional multi-port, shut-off valve may be used to isolate the line pressure and provide a means of testing or readjusting the pressure sensor while in service or to serve as a gauge valve. Pressure sensor and multi-port, shut-off valves require field installation, and lines denoted by  are to be provided and piped by the customer. Set point of the filter regulator is the operating pressure stamped on the actuator's nameplate.

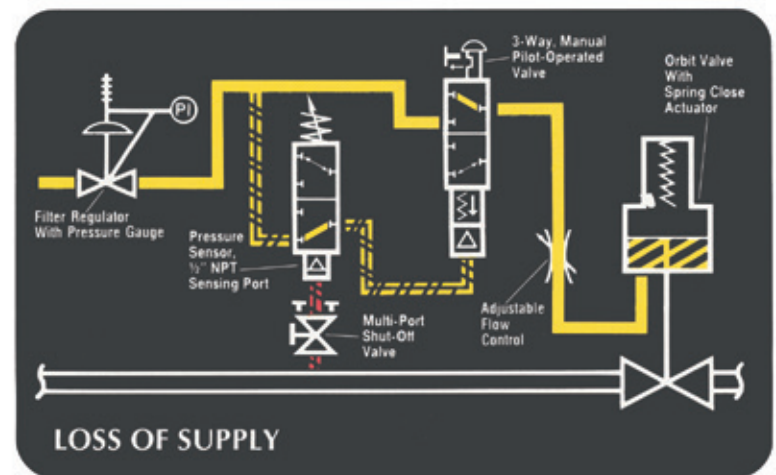

\* For a high-low-pressure shutdown system, order A-12385. A high-low sensor pair will be provided.

- NORMAL LINE PRESSURE
- AIR PRESSURE
- HIGH LINE PRESSURE
- AIR EXHAUST

## Systems for Spring-Open Actuators

### ELECTRIC SIGNAL TO CLOSE, FAIL OPEN ON LOSS OF SIGNAL – A-12682\*

The electric signal activates the three-way, normally closed, solenoid-operated, spring-return valve, allowing supply pressure to move the actuator and valve to the closed position. The closing speed is controlled by adjusting the flow control.

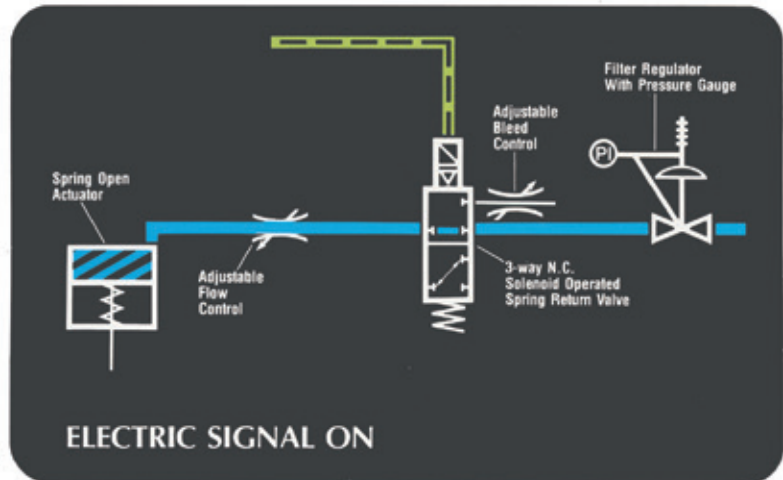

Loss of electric signal returns the three-way valve to the normally closed position, allowing the actuator and valve to spring open. The opening speed is controlled by adjusting the bleed control. Set pressure of the filter regulator is in accordance with the operating pressure indicated on the actuator's nameplate.

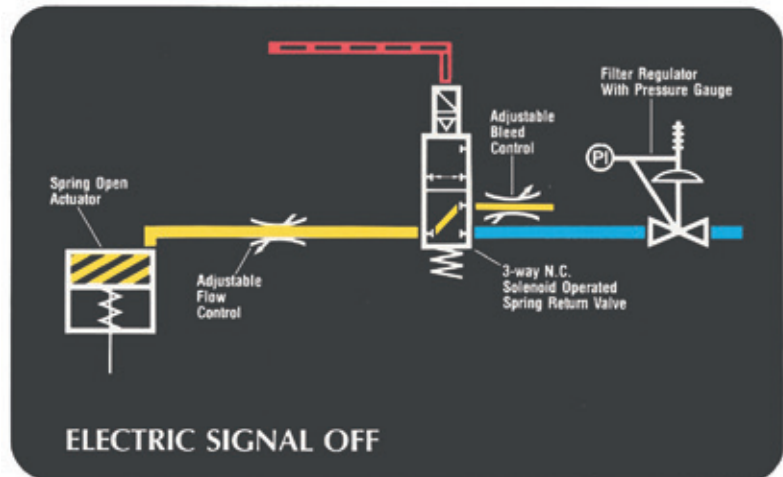

\* Fail action will occur if supply pressure is completely lost (drops to 0 psig). A-12864 is required if a small-ported solenoid valve (less than 1/8") is used. See page 12. For a pneumatic signal, order A-12306.

- SIGNAL ON      ■ AIR PRESSURE
- SIGNAL OFF    ■ AIR EXHAUST

## ELECTRIC SIGNAL TO CLOSE, FAIL OPEN ON LOSS OF SIGNAL OR SUPPLY PRESSURE – A-12455\*

The electric signal activates the three-way, normally closed, solenoid-operated, spring-return valve, allowing supply pressure to move the actuator and valve to the closed position. The closing speed is controlled by adjusting the flow control.

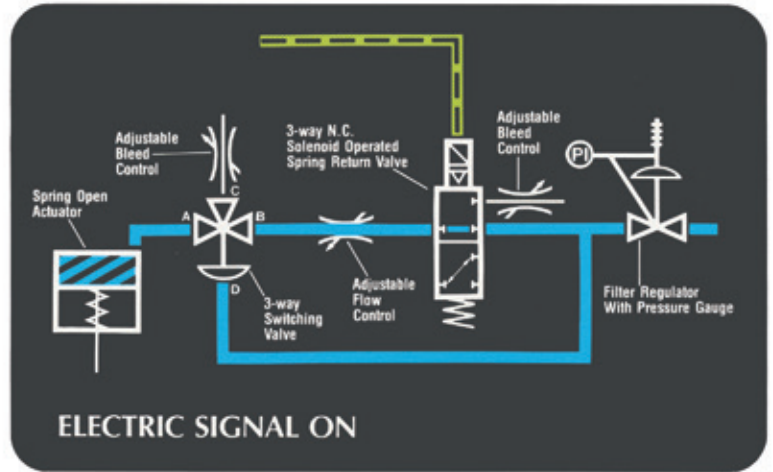

Loss of electric signal returns the three-way valve to the normally closed position, allowing the actuator and valve to spring open. The opening speed is controlled by adjusting the bleed control. Set pressure of the filter regulator is in accordance with the operating pressure indicated on the actuator's nameplate.

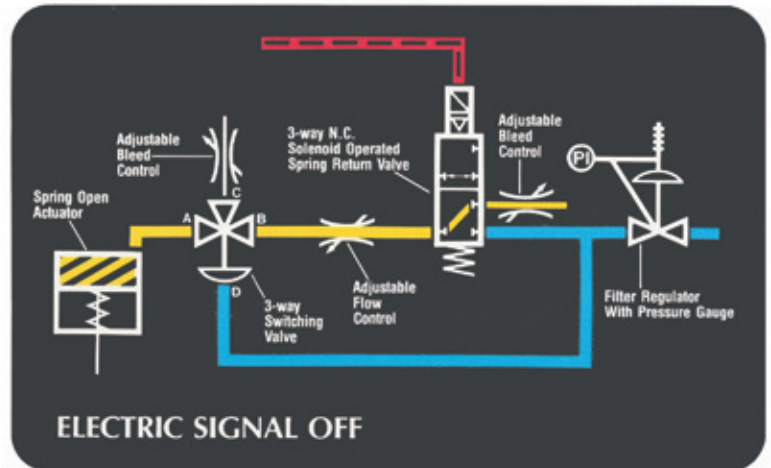

To allow the actuator to fail open on loss of supply air, a three-way switching valve is set to 10 psi (0.7 bar) below the maximum operating pressure. When pressure at port "D" is above the set point, ports "A" and "B" are connected and port "C" is blocked. When pressure at port "D" falls below the set point, ports "A" and "C" are connected and port "B" is blocked, allowing the actuator and valve to spring open.

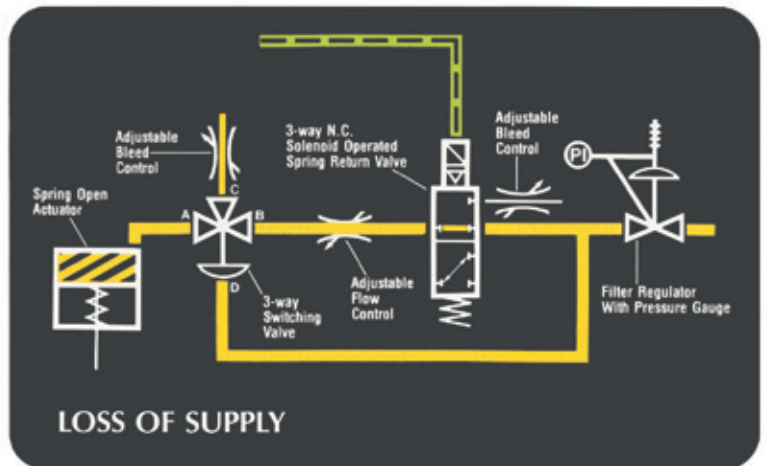

\* For a pneumatic signal, order A-12309. A-12864 is required if a small-ported solenoid valve (less than 1/8") is used. See page 12.

- SIGNAL ON      ■ AIR PRESSURE
- SIGNAL OFF    ■ AIR EXHAUST

## Systems for Double-Acting Actuators

### PNEUMATIC SIGNAL TO OPEN, FAIL CLOSE ON LOSS OF SIGNAL – A-12104\*

The pneumatic signal activates the four-way, two-position, pneumatic-operated, spring-return valve, allowing supply pressure to move the actuator and valve to the open position. The opening speed is controlled by adjusting the bleed control.

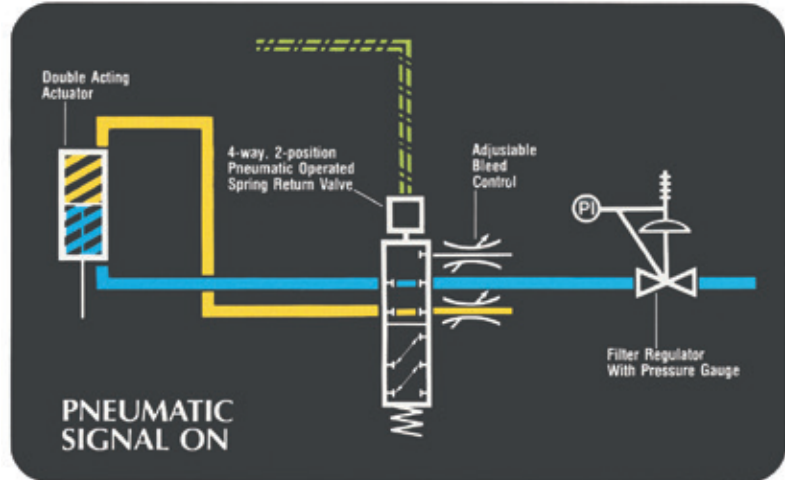

Loss of pneumatic signal returns the four-way valve to the normal position, allowing the actuator and valve to close. The closing speed is controlled by adjusting the bleed control. Set pressure of the filter regulator is in accordance with the operating pressure indicated on the actuator's nameplate.

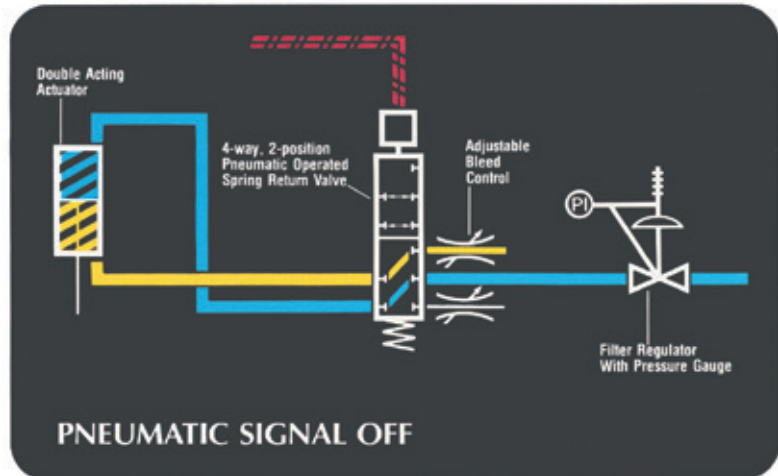

\* For an electric signal, order A-12105. For a fail open and pneumatic signal, order A-12741. For a fail open and electric signal, order A-13666.

- SIGNAL ON
- AIR PRESSURE
- SIGNAL OFF
- AIR EXHAUST



## ELECTRIC SIGNAL TO OPEN, FAIL CLOSE ON LOSS OF SIGNAL – A-12107\*

The electric signal activates the four-way, two-position, electric, solenoid-operated, spring-return valve, allowing supply pressure to move the actuator and the valve to the open position. The opening speed is controlled by adjusting the bleed control.

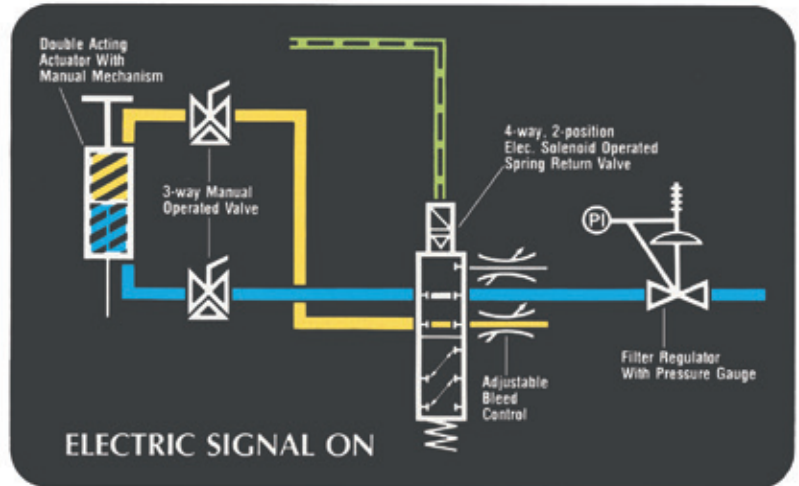

Loss of electric signal returns the four-way valve to the normal position, allowing the actuator and valve to close. The closing speed is controlled by adjusting the bleed control.

Set pressure of the filter regulator is in accordance with the operating pressure indicated on the actuator's nameplate. To operate the manual mechanism, pressure is relieved from the actuator with a three-way, manually-operated valve.

For override operation, see page 33.

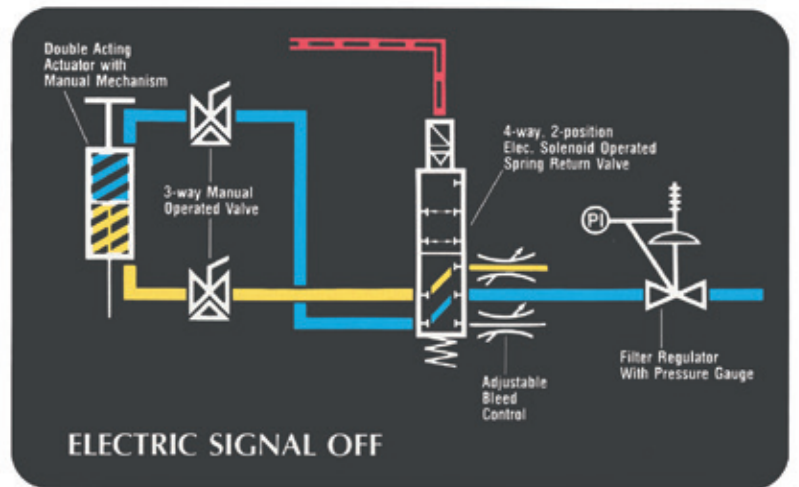

\* For a pneumatic signal, order A-12106. For a fail open and pneumatic signal, order A-12978. For a fail open and electric signal, order A-12413.

■ SIGNAL ON      ■ AIR PRESSURE  
■ SIGNAL OFF    ■ AIR EXHAUST

## PNEUMATIC SIGNAL TO OPEN, FAIL CLOSE ON LOSS OF SIGNAL OR SUPPLY PRESSURE – A-12108\*

The pneumatic signal activates the four-way, two-position, pneumatic-operated, spring-return valve, allowing supply pressure to move the actuator and valve to the open position. The opening speed is controlled by adjusting the bleed control.

Loss of pneumatic signal returns the four-way valve to the normal position, allowing supply pressure to move the actuator and valve to the closed position. The closing speed is controlled by adjusting the bleed control.

Set pressure of the filter regulator is in accordance with the operating pressure indicated on the actuator's nameplate.

To allow the actuator to fail close on loss of supply air, a three-way switching valve is set to 10 psi (0.7 bar) below the maximum operating pressure. When pressure at port "D" is above the set point, ports "A" and "B" are connected, allowing the pneumatic signal to activate the four-way valve. When pressure at port "D" falls below the set point, ports "A" and "C" are connected and port "B" is blocked, preventing the pneumatic signal from activating the four-way valve and exhausting signal air from the four-way valve. The accumulator and check valves provide adequate supply pressure to close the valve on loss of supply pressure.

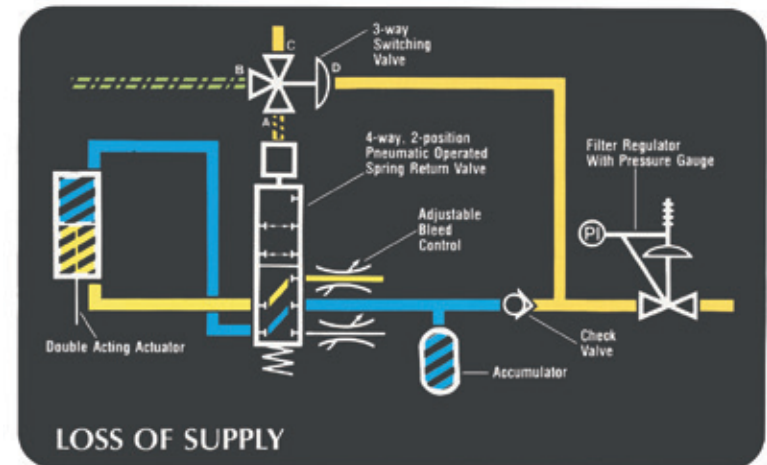
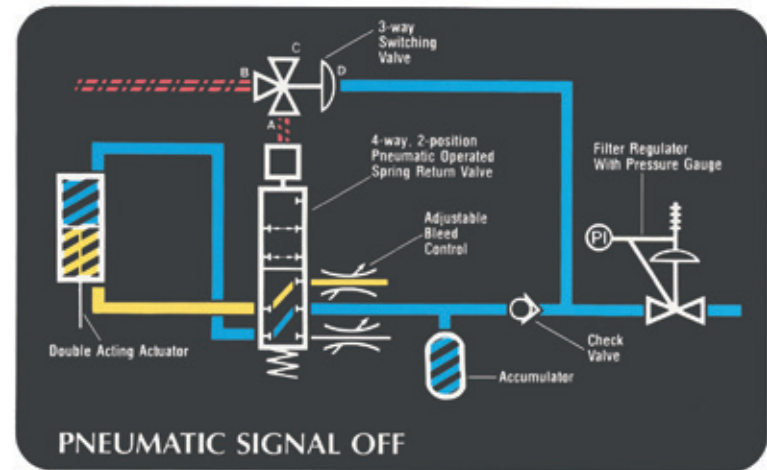
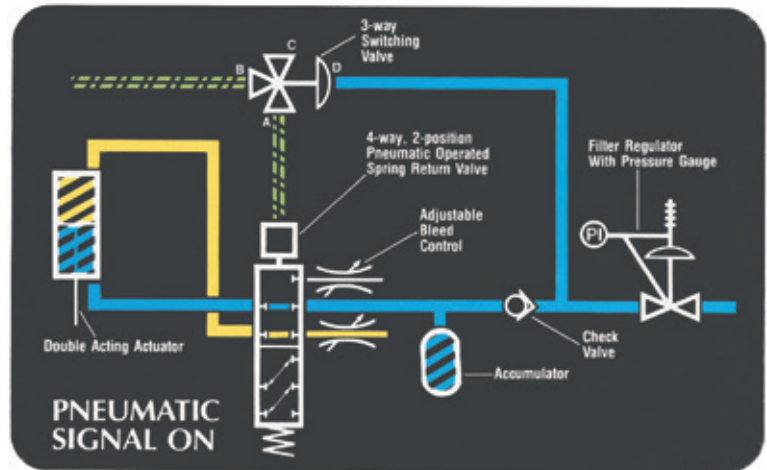

- SIGNAL ON
- SIGNAL OFF
- AIR PRESSURE
- AIR EXHAUST

\* For a fail close on an actuator with manual mechanism, order A-12109. For a fail open, order A-12677. For a fail open on an actuator with manual mechanism, order A-12702. These assemblies require a pressure reserve tank (accumulator, volume tank), which is ordered separately.

## ELECTRIC SIGNAL TO OPEN, FAIL CLOSE ON LOSS OF SIGNAL OR SUPPLY PRESSURE – A-12276\*

The electric signal activates the three-way, normally closed, solenoid-operated spring-return valve, allowing supply pressure to activate the four-way, two-position, pneumatic-operated, spring-return valve, which allows supply pressure to move the actuator and valve to the open position. The opening speed is controlled by adjusting the bleed control.

Loss of electric signal returns the three-way valve to the normal position, relieving pressure from the four-way valve, allowing the actuator and valve to move to the closed position. The closing speed is controlled by adjusting the bleed control. Set pressure of the filter regulator is in accordance with the operating pressure indicated on the actuator's nameplate.

To allow the actuator to fail close on loss of supply pressure, a three-way switching valve is set to 10 psi (0.7 bar) below the maximum operating pressure. When pressure at port "D" is above the set point, port "A" and "B" are connected, allowing the pneumatic signal to activate the four-way valve. When pressure at port "D" falls below the set point, ports "A" and "C" are connected and port "B" is blocked, preventing the supply pressure from activating the four-way valve and exhausting signal air from the four-way valve. The accumulator and check valve provide adequate supply pressure to close the valve on loss of supply pressure.

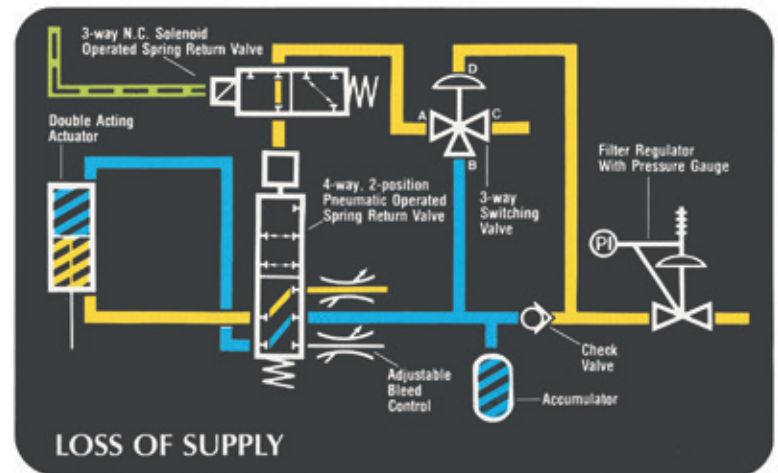
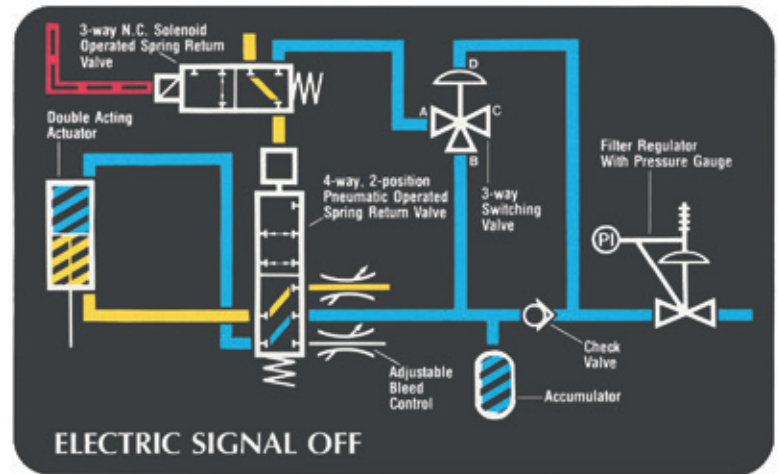
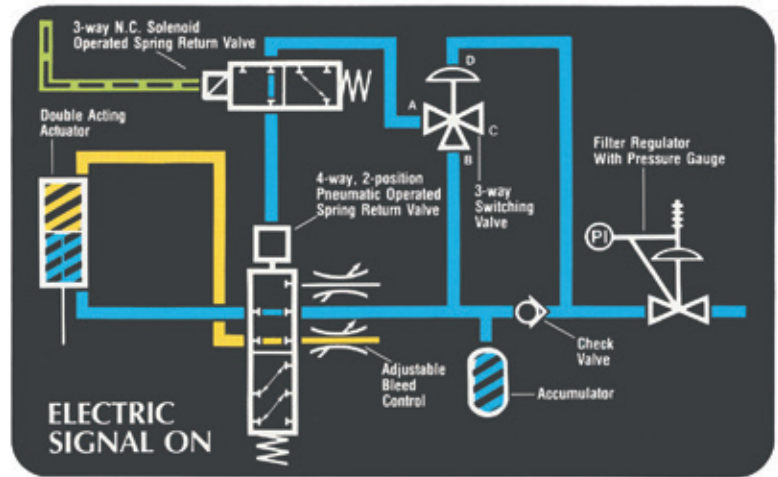

\* These assemblies require a pressure reserve tank (accumulator, volume tank), which is ordered separately.

- SIGNAL ON      ■ AIR PRESSURE
- SIGNAL OFF    ■ AIR EXHAUST

## ELECTRIC SIGNAL TO OPEN, FAIL CLOSE ON LOSS OF SIGNAL OR SUPPLY PRESSURE – A-12299\*

The electric signal activates the three-way, normally closed, solenoid-operated, spring-return valve, allowing supply pressure to activate the four-way, two-position, pneumatic-operated, spring-return valve, which allows supply pressure to move the actuator and valve to the open position. The opening speed is controlled by adjusting the bleed control.

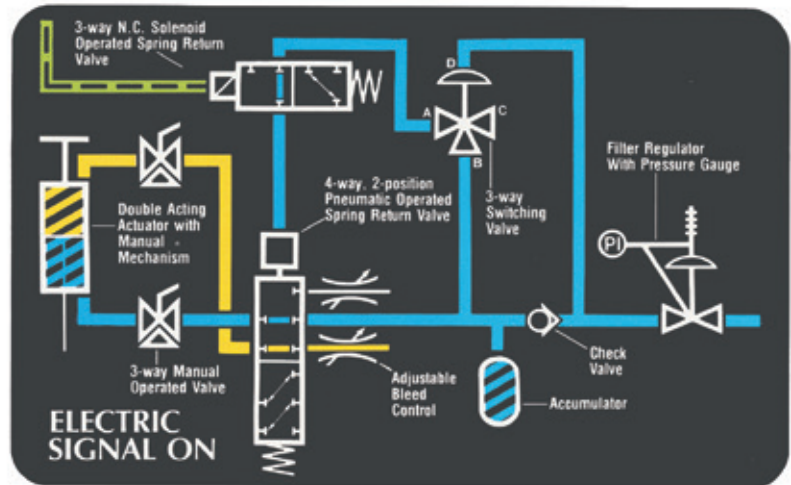

Loss of electric signal returns the three-way valve to the normal position, relieving pressure from four-way valve, returning it to the normal position, allowing the actuator and valve to move to the closed position. The closing speed is controlled by adjusting the bleed control. Set pressure of the filter regulator is in accordance with the operating pressure indicated on the actuator's nameplate. To operate the manual mechanism, pressure is relieved from the actuator with the three-way manually operated valve.

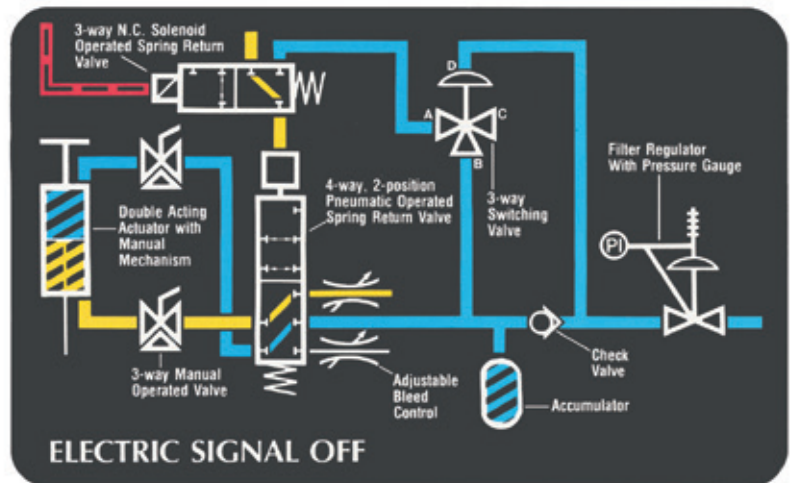

For override operation, see page 33.

To allow the actuator to fail close on loss of supply pressure, a three-way switching valve is set to 10 psi (0.7 bar) below the maximum operating pressure. When pressure at port "D" is above the set point, ports "A" and "B" are connected, allowing the supply pressure to activate the four-way valve. When pressure at port "D" falls below the set point, ports "A" and "C" are connected and port "B" is blocked, preventing the supply pressure from activating the four-way valve and exhausting signal air from the four-way valve. The accumulator and check valve provide adequate supply pressure to close the valve on loss of supply pressure.

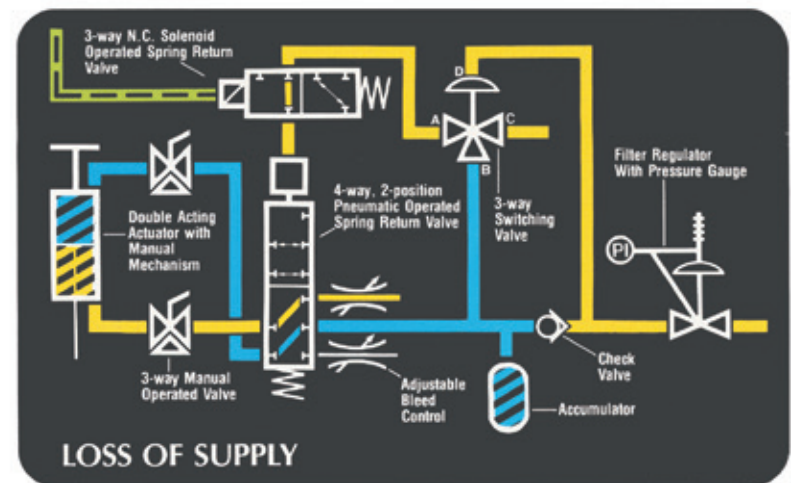

\* These assemblies require a pressure reserve tank (accumulator, volume tank), which is ordered separately.

- SIGNAL ON
- AIR PRESSURE
- SIGNAL OFF
- AIR EXHAUST



## PNEUMATIC SIGNAL TO OPEN, FAIL CLOSE ON LOSS OF SIGNAL OR SUPPLY PRESSURE, MANUAL RESET TO OPEN – A-13860

The ORBIT valve is opened by manually moving the lever of the four-way valve to the latched position, and it is kept open with a pneumatic signal (routed through a three-way switching valve). The opening speed is controlled by adjusting the bleed control.

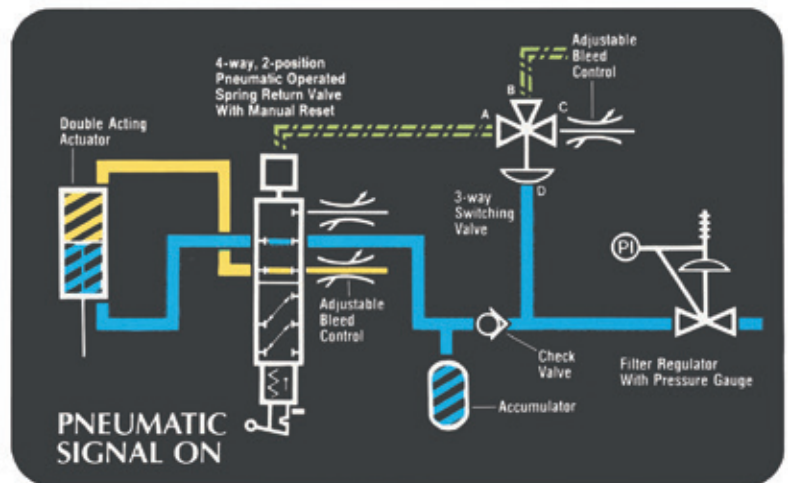

Loss of pneumatic signal makes the four-way valve spring return and directly supply pressure to the top of the actuator to close the ORBIT valve. The four-way valve must be manually reset to re-open the ORBIT valve. The closing speed is controlled by adjusting the bleed control.

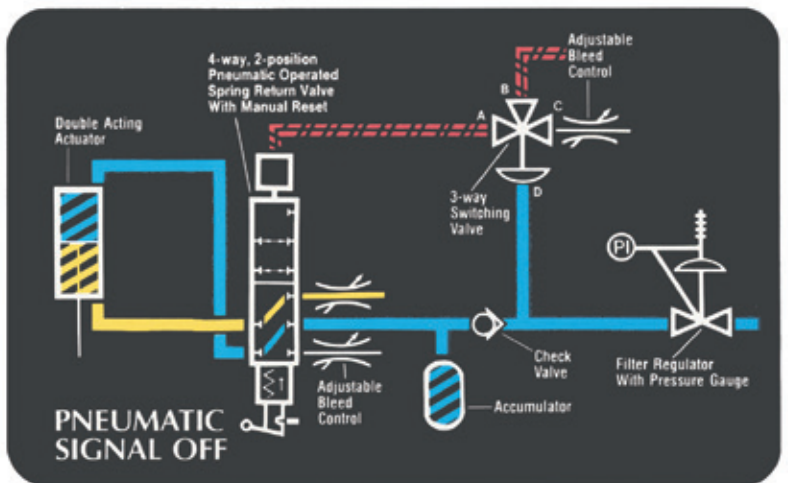

To allow the actuator to fail close on loss of supply pressure a three-way switching valve is set to 10 psi (0.7 bar) below the maximum operating pressure. When pressure at port "D" is above the set point, ports "A" and "B" are connected, allowing the pneumatic signal to activate the four-way valve. When pressure at port "D" falls below the set point, ports "A" and "C" are connected and port "B" is blocked, preventing the pneumatic signal from activating the four-way valve, and exhausting signal air from the four-way valve. The accumulator and check valve provide adequate supply pressure to close the valve on loss of supply pressure.

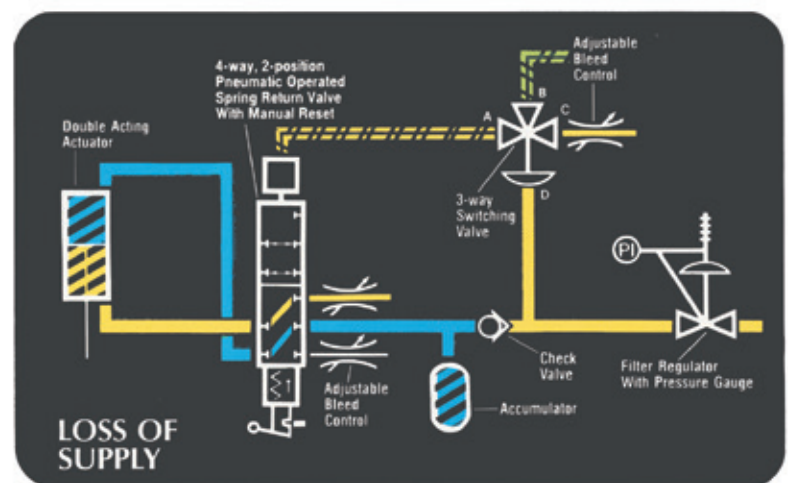

- SIGNAL ON
- AIR PRESSURE
- SIGNAL OFF
- AIR EXHAUST

## ELECTRIC SIGNAL TO OPEN, FAIL CLOSE ON LOSS OF SIGNAL OR SUPPLY PRESSURE, MANUAL RESET TO OPEN – A-12719

The ORBIT valve is opened by manually moving the lever on the three-way solenoid valve to the latched position with the solenoid energized. When shifted, the three-way valve applies a pneumatic signal to the pilot of the four-way valve, which directs supply pressure to the bottom of the actuator to open the ORBIT valve. The opening speed is controlled by adjusting the bleed control.

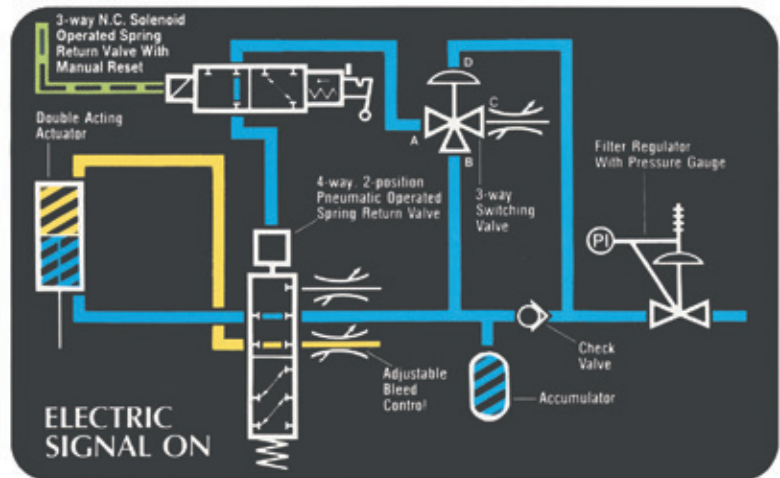

Loss of electric signal returns the three-way solenoid valve to the normally closed position and vents the pneumatic signal from the pilot of the four-way valve. The four-way valve shifts and directs supply pressure to the top of the actuator to close the ORBIT valve. The manual latch on the three-way solenoid valve trips on the loss of the signal and must be manually reset to re-open the ORBIT valve. The closing speed is controlled by adjusting the bleed control.

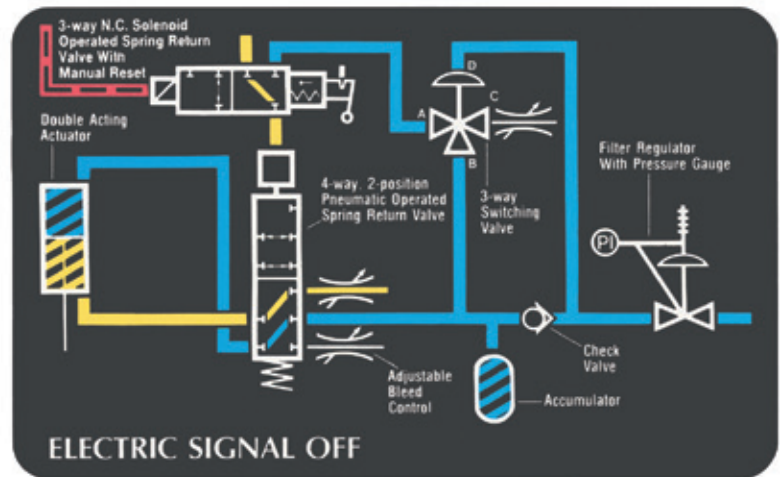

To allow the actuator to fail close on loss of supply pressure, a three-way switching valve is set to 10 psi (0.7 bar) below the maximum operating pressure. When pressure at port "D" is above the set point, ports "A" and "B" are connected, allowing the supply pressure to activate the four-way valve. When pressure at port "D" falls below the set point, ports "A" and "C" are connected and port "B" is blocked, preventing the supply pressure from activating the four-way valve and exhausting signal air from the four-way valve. The accumulator and check valve provide adequate supply pressure to close the valve on loss of supply pressure.

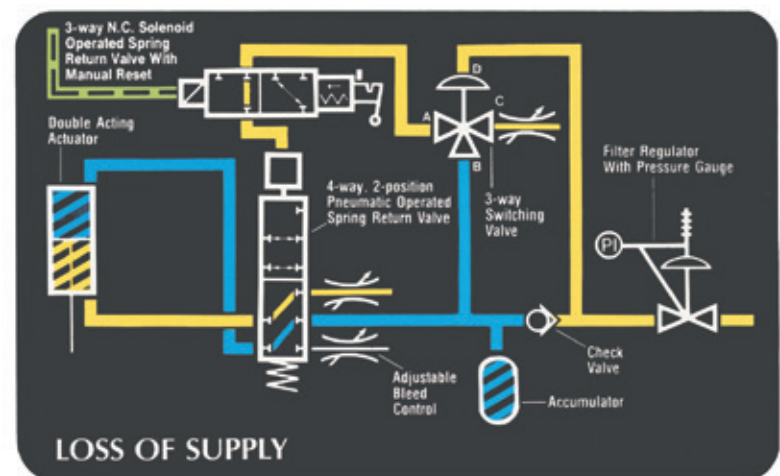

- SIGNAL ON
- AIR PRESSURE
- SIGNAL OFF
- AIR EXHAUST

## ELECTRIC SIGNAL TO OPEN, FAIL CLOSE ON LOSS OF SIGNAL OR SUPPLY PRESSURE – A-12345\*

The electric signal activates the three-way, normally closed, solenoid-operated, spring-return valve, allowing supply pressure to switch the four-way, two-position, pneumatic-operated, spring-return valve, which allows supply pressure to move the actuator and valve to the closed position. The closing speed is controlled by adjusting the bleed control.

Loss of electric signal returns the three-way valve spring to the normally closed position. This action allows the four-way valve to spring return, allowing the actuator and valve to move to the open position. The opening speed is controlled by adjusting the bleed control. Set pressure of the filter regulator is in accordance with the operating pressure indicated on the actuator's nameplate.

To allow the actuator to fail open on loss of supply pressure a three-way switching valve is set to 10 psi (0.7 bar) below the maximum operating pressure. When pressure at port "D" is above the set point, ports "A" and "B" are connected, allowing the pneumatic signal to activate the four-way valve. When pressure at port "D" falls below the set point, ports "A" and "C" are connected and port "B" is blocked, preventing the pneumatic signal from activating the four-way valve, and exhausting signal air from the four-way valve. The accumulator and check valve provide adequate supply pressure to open the valve on loss of supply pressure.

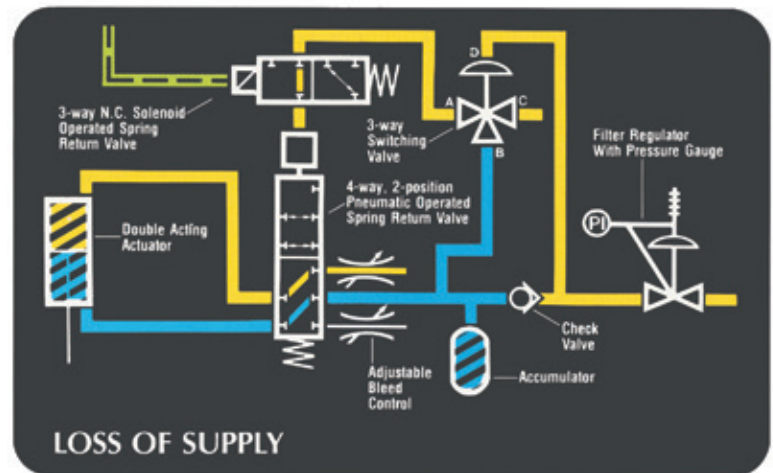
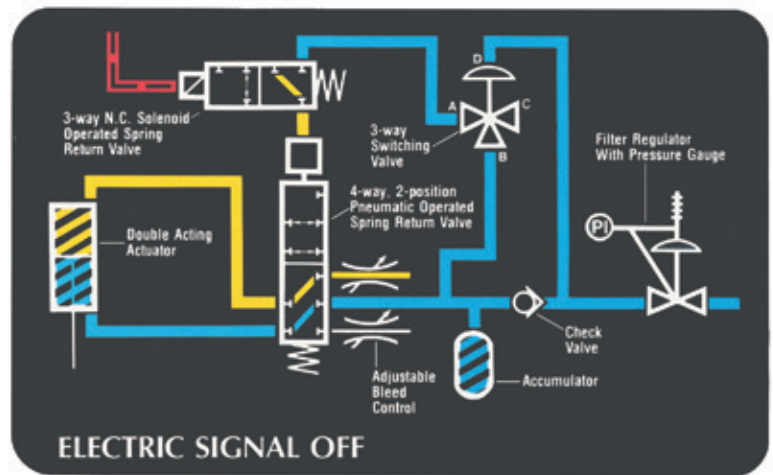
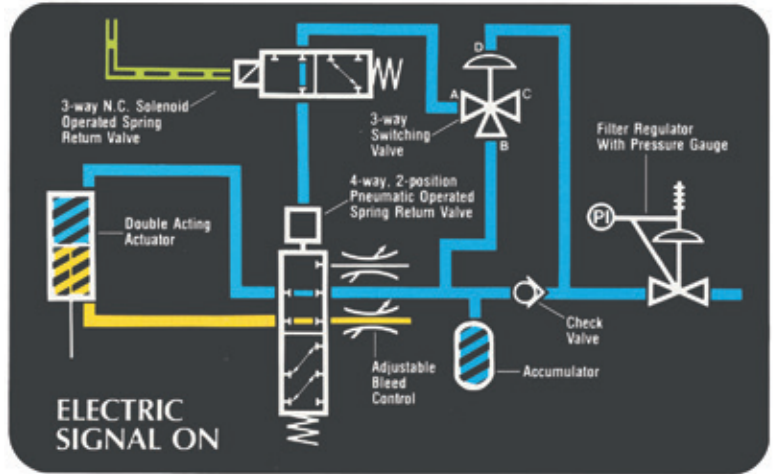

\* These assemblies require a pressure reserve tank (accumulator, volume tank), which is ordered separately. For an actuator with manual mechanism, order A-12680.

- SIGNAL ON
- SIGNAL OFF
- AIR PRESSURE
- AIR EXHAUST

## ELECTRIC SIGNAL TO OPEN AND CLOSE, FAIL IN POSITION

### ON LOSS OF SIGNAL – A-12111\*

The electric signal to solenoid “A” activates the four-way, two-position, dual, solenoid-operated valve, allowing supply pressure to move the actuator to the valve open position. On loss of signal, the four-way valve remains in the same position. The opening speed is controlled by adjusting the bleed control.

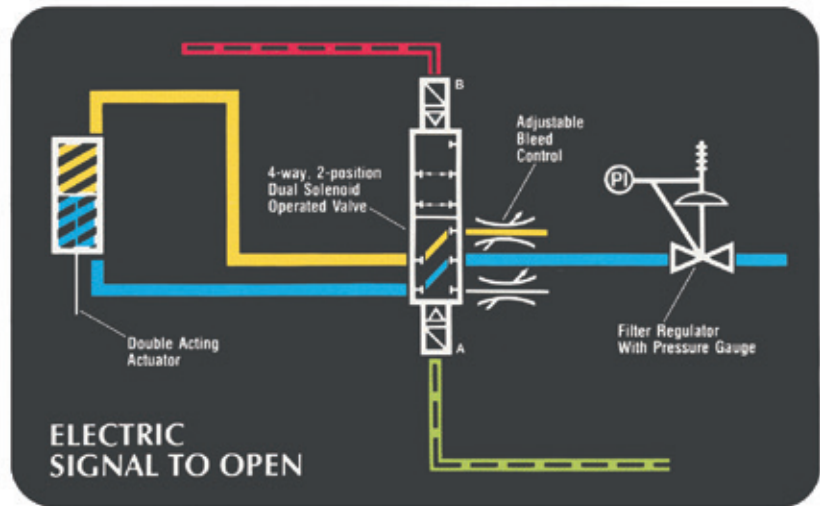

The electric signal to solenoid “B” activates the four-way valve, allowing supply pressure to move the actuator and valve to the closed position. On loss of signal, the four-way valve remains in the same position. The closing speed is controlled by adjusting the bleed control. Set pressure of the filter regulator is in accordance with the operating pressure indicated on the actuator’s nameplate.

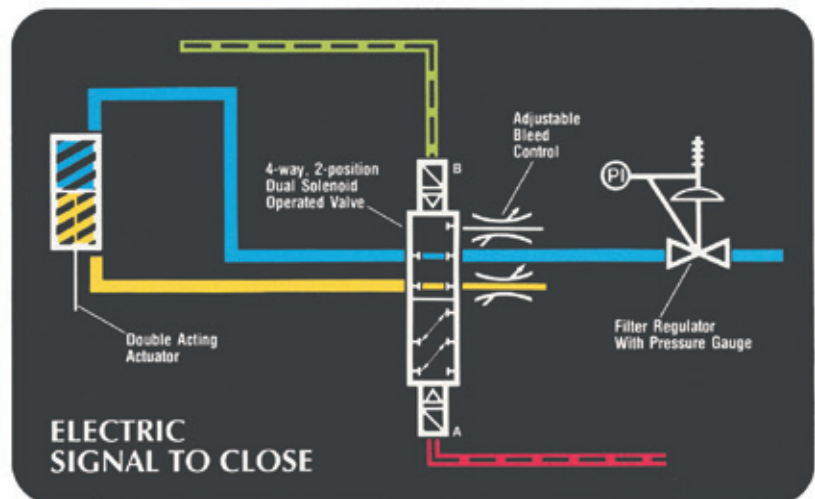

\* For a pneumatic signal, order A-12110. For a pneumatic signal on an actuator with manual mechanism, order A-12112. For an electric signal using a single-exhaust solenoid, order A-13289. For an electric signal on an actuator with manual mechanism, order A-12113. For an electric signal using exhaust solenoid on an actuator with manual mechanism, order A-12814. Refer to A-14983 (pages 33-34) for the typical single-exhaust solenoid flow pattern.

- SIGNAL ON
- AIR PRESSURE
- SIGNAL OFF
- AIR EXHAUST



## ELECTRIC SIGNAL TO OPEN AND CLOSE, FAIL IN POSITION ON LOSS OF SIGNAL OR SUPPLY PRESSURE – A-12115\*

The electric signal to solenoid “A” activates the four-way valves, allowing supply pressure to move the actuator and valve to the open position. On loss of signal, the four-way valve will remain in position. The opening speed is controlled by adjusting the bleed control.

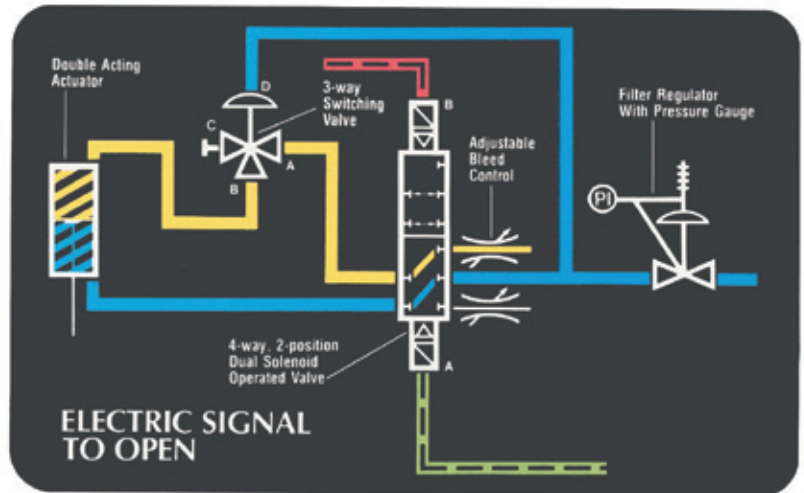

The electric signal to solenoid “B” activates the four-way, two-position, dual, pilot-operated valve, allowing supply pressure to move the actuator valve to the closed position. On loss of signal, the four-way valve will remain in position. The closing speed is controlled by adjusting the bleed control. Set pressure of the filter regulator is in accordance with the operating pressure indicated on the actuator’s nameplate.

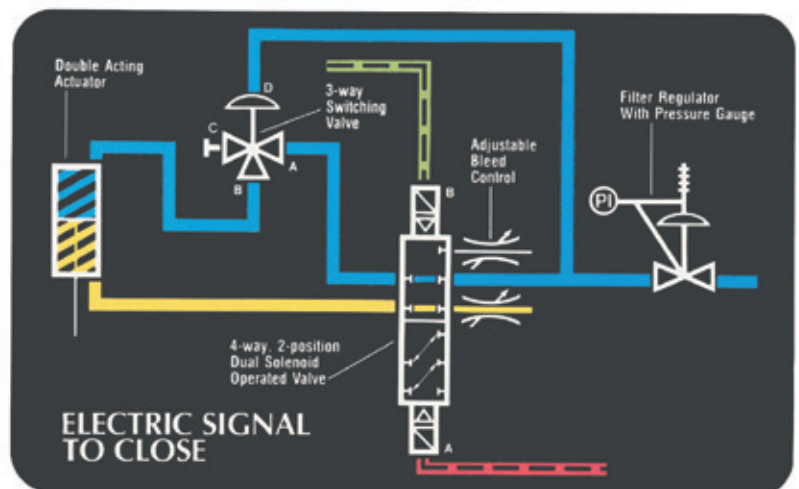

(Continued on next page.)

\*For a pneumatic signal, order A-12114.

- SIGNAL ON
- AIR PRESSURE
- SIGNAL OFF
- AIR EXHAUST

## ELECTRIC SIGNAL TO OPEN AND CLOSE, FAIL IN POSITION ON LOSS OF SIGNAL OR SUPPLY PRESSURE – A-12115\*

To allow the actuator to fail in position, a three-way switching valve is set to 10 psi (0.7 bar) below the maximum pressure. When the maximum operating pressure at port "D" is above the set point, ports "A" and "B" are connected and port "C" is blocked. When pressure at port "D" falls below set points, port "A" and "C" are connected and port "B" is blocked. If the actuator is in the valve's open position when port "B" is blocked, the valve will remain open. If the valve is in the closed position when port "B" is blocked, the valve will remain closed.

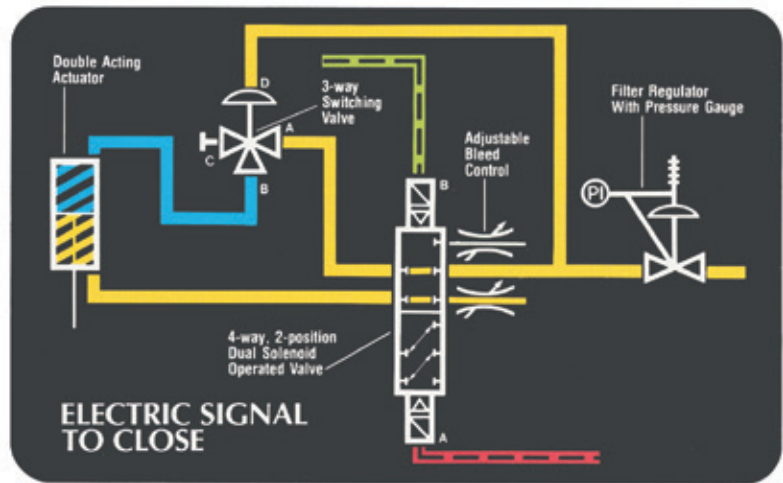
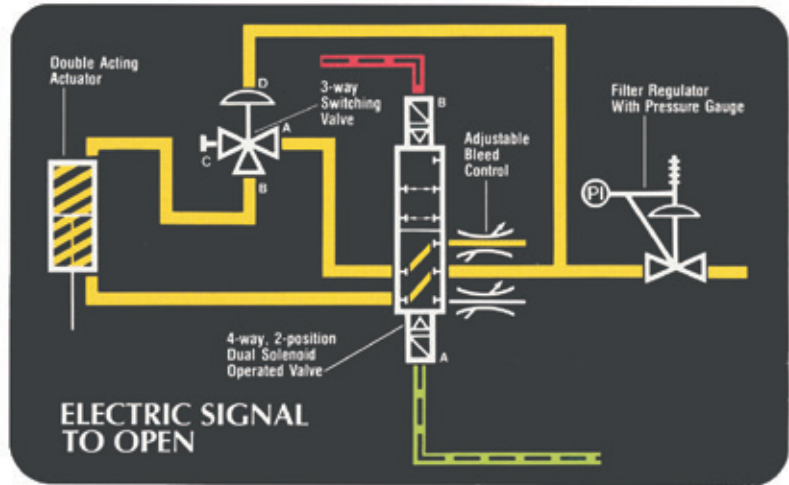

\* For a pneumatic signal, order A-12114.

- SIGNAL ON
- AIR PRESSURE
- SIGNAL OFF
- AIR EXHAUST

## ELECTRIC SIGNAL TO OPEN AND CLOSE, FAIL IN POSITION ON LOSS OF SIGNAL OR SUPPLY PRESSURE – A-12117\*

The electric signal to solenoid “A” activates the four-way valve, allowing supply pressure to move the actuator and valve to the open position. On loss of signal, the four-way valve will remain in position. The opening speed is controlled by adjusting the bleed control.

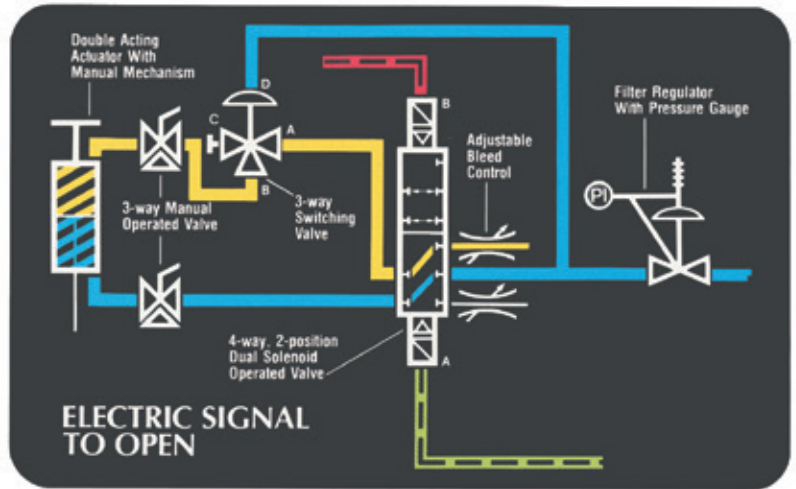

The electric signal to solenoid “B” activates the four-way, two-position, dual, pilot-operated valve, allowing supply pressure to move the actuator valve to the closed position. On loss of signal, the four-way valve will remain in position. The closing speed is controlled by adjusting the bleed control. Set pressure of the filter regulator is in accordance with the operating pressure indicated on the actuator’s nameplate. For override operation, see page 35.

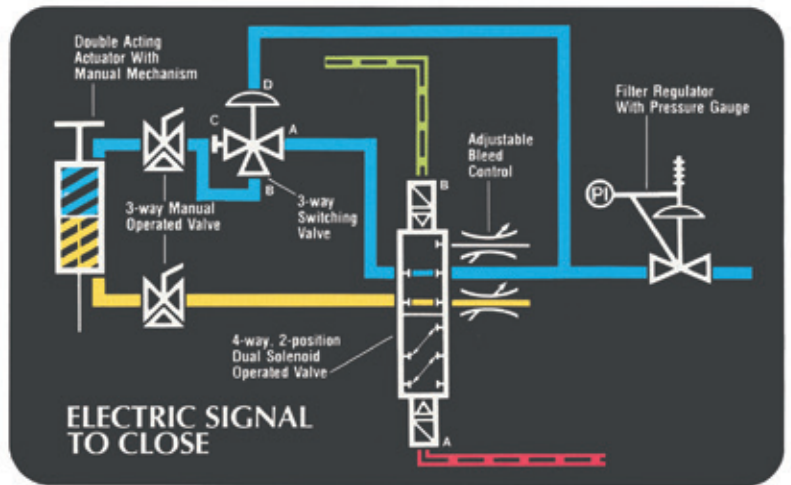

(Continued on next page.)

\* For a pneumatic signal, order A-12116.

- NORMAL LINE PRESSURE
- AIR PRESSURE
- HIGH LINE PRESSURE
- AIR EXHAUST

## ELECTRIC SIGNAL TO OPEN AND CLOSE, FAIL IN POSITION ON LOSS OF SIGNAL OR SUPPLY PRESSURE – A-12117\*

To allow the actuator to fail in position on loss of supply pressure, a three-way switching valve is set to 10 psi (0.7 bar) below the maximum operating pressure. When pressure at port "D" is above set points, ports "A" and "B" are connected and port "C" is blocked. When operating pressure falls below the set point, ports "A" and "C" are connected and port "B" is blocked. If the actuator is in the valve's open position when port "B" is blocked, the valve will remain open. If the actuator is in the valve's closed position when port "B" is blocked, the valve will remain in the closed position.

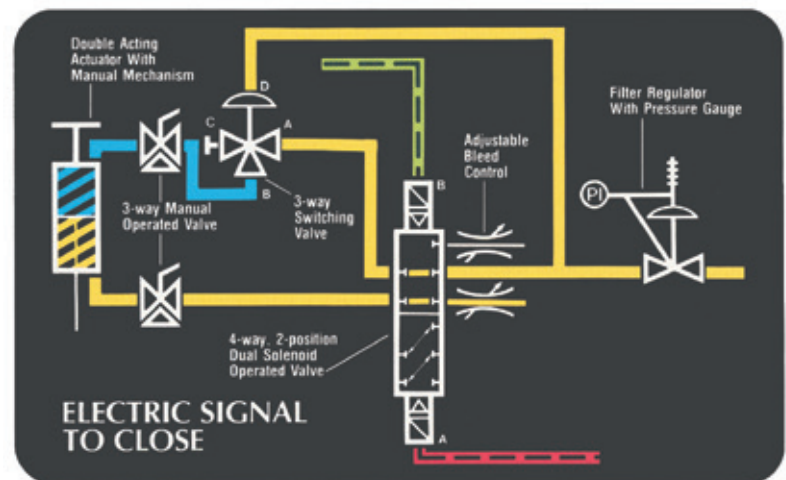
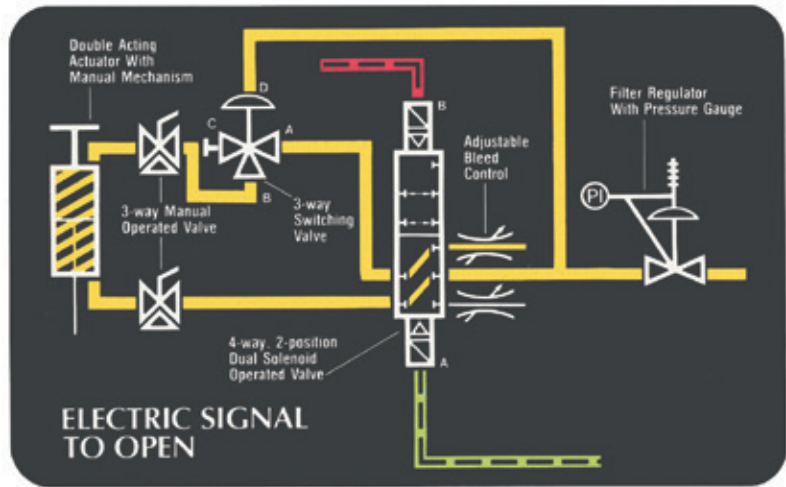

\* For a pneumatic signal, order A-12116.

- SIGNAL ON
- AIR PRESSURE
- SIGNAL OFF
- AIR EXHAUST



## ELECTRIC SIGNAL OR SUPPLY PRESSURE, SINGLE-EXHAUST SOLENOID – A-14983\*

The electric signal to solenoid “A” of the four-way valve directs supply pressure to the top of the actuator to close the ORBIT valve. The closing speed is controlled by adjusting the flow control. The electric signal may be continuous or momentary. The four-way valve and ORBIT valve will remain in position on loss of signal.

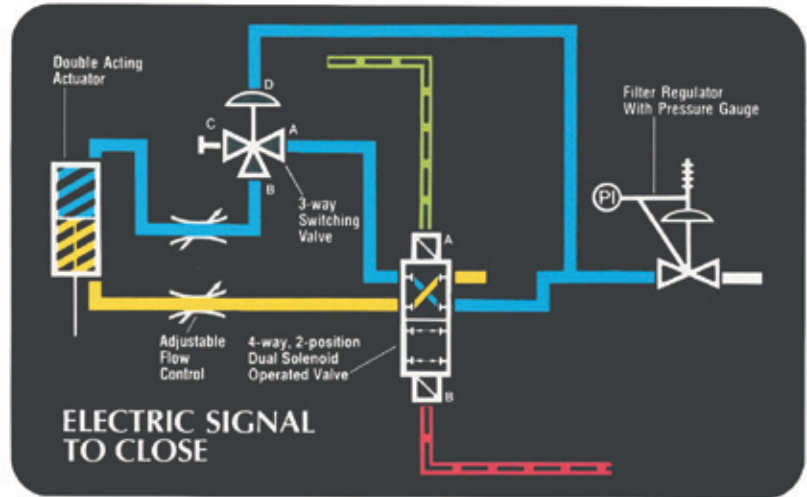

The electric signal to solenoid “B” of the four-way valve directs supply pressure to the bottom of the actuator to open the ORBIT valve. The opening speed is controlled by adjusting the flow control. Set point of the filter regulator is the operating pressure stamped on the actuator’s nameplate.

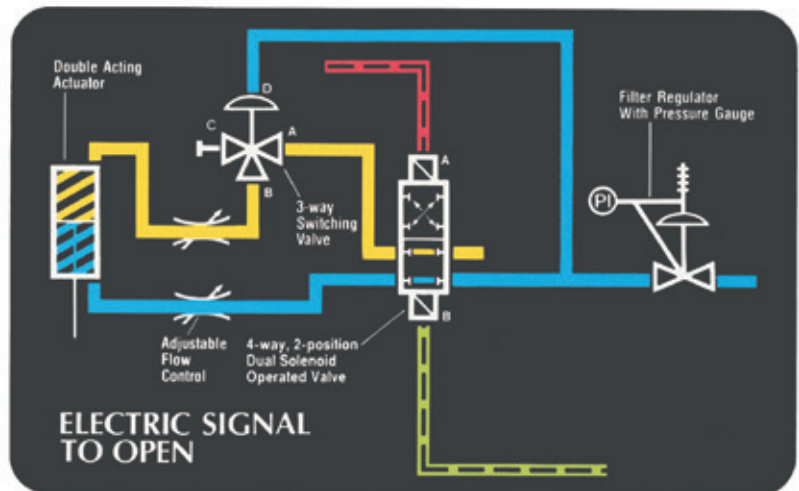

(Continued on next page.)

\* For an actuator with manual mechanism, order A-12946.

- SIGNAL ON
- AIR PRESSURE
- SIGNAL OFF
- AIR EXHAUST

## ELECTRIC SIGNAL OR SUPPLY PRESSURE, SINGLE-EXHAUST SOLENOID – A-14983\*

To allow the actuator to fail in position on loss of supply pressure, a three-way switching valve is set to 10 psi (0.7 bar) below the maximum operating pressure. When pressure at port “D” is above set points, ports “A” and “B” are connected and port “C” is blocked. When operating pressure falls below the set point, ports “A” and “C” are connected and port “B” is blocked. If the actuator is in the valve’s open position when port “B” is blocked, the valve will remain open. If the actuator is in the valve’s closed position when port “B” is blocked, the valve will remain in the closed position.

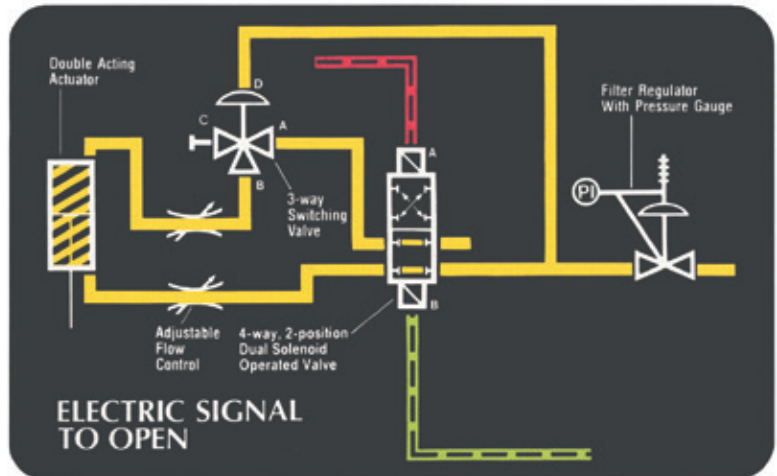
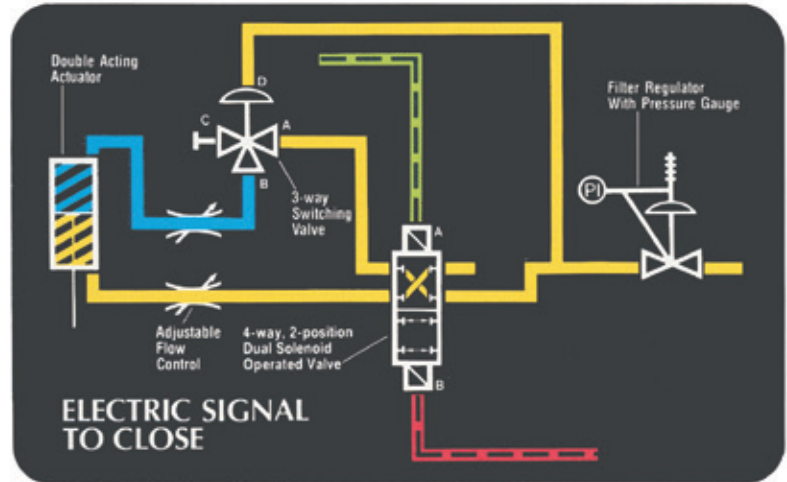

\* For an actuator with manual mechanism, order A-12946.

- SIGNAL ON
- AIR PRESSURE
- SIGNAL OFF
- AIR EXHAUST

## VERRIDE OPERATION

To operate the manual override mechanism, on packages so equipped, you must relieve pressure from the actuator by use of the three-way valves. Only one three-way valve is to be operated at any one time. The valve to be operated is determined by the position of the actuator.

If the valve is to be locked into an already cycled position by using the manual mechanism, operating the three-way valves is not required.

- AIR PRESSURE
- AIR EXHAUST

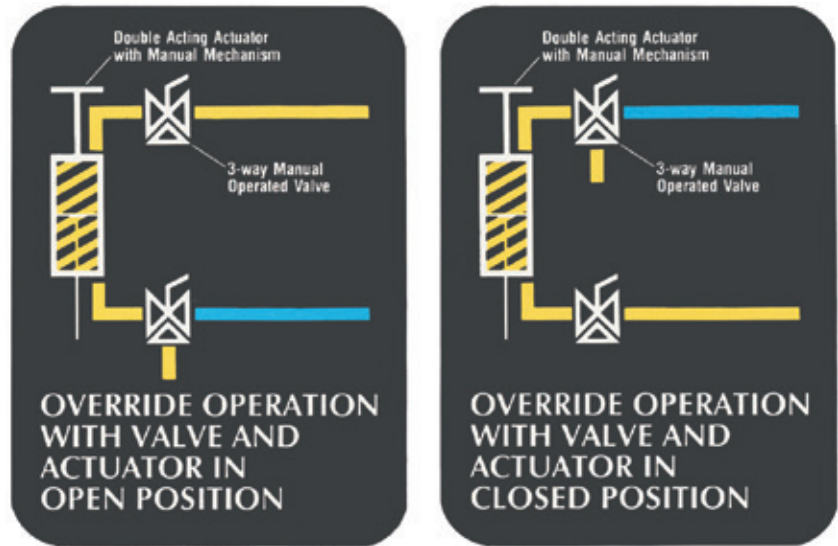

### Information Required to Order Pneumatic Automated Systems Other Than Standard Packages

1. Valve Size, Rating and Trim
2. Full or Reduced Port
3. End Connection
4. Actuator Type: Double-acting, Spring-close or Spring-open
5. Manual Override: None Required, One-way or Two-way
6. Position of Valve Stem: Vertical or Horizontal
7. Operating Source (Air or Gas) and Pressure
8. Speed of Operation in Seconds
9. Maximum Differential Pressure Across Closed Valve Applied from Preferred Pressure End and From Seat End
10. Type: Fail Close on Loss of Signal, Loss of Signal and Supply or Other  
Type: Fail Open on Loss of Signal, Loss of Signal and Supply or Other  
Type: Fail in Position (Lock) on Loss of Signal, Loss of Signal and Supply or Other  
Type: Any Other Control System Information
11. Signal: Single or Dual  
If Electric: Voltage DC or AC, Phase, Hz  
If Pneumatic: Control Signal Pressure
12. Material:  
Tubing – Stainless Steel, Copper, Other; Components (i.e., Solenoid Valve, Switching Valve) – Brass, Stainless Steel, Other
13. Electrical Area Classification and Required Approvals or Listings
14. Other System Requirements
15. Limit Switches: Open, Close, Other; Type CX, Pneumatic, Proximity, Other
16. Number of Contacts Required: In Open Position, Closed Position, Other

## ADAPTATION OF CX MICRO SWITCH TO ORBIT DIAPHRAGM AND PISTON ACTUATORS

### Diaphragm Actuators

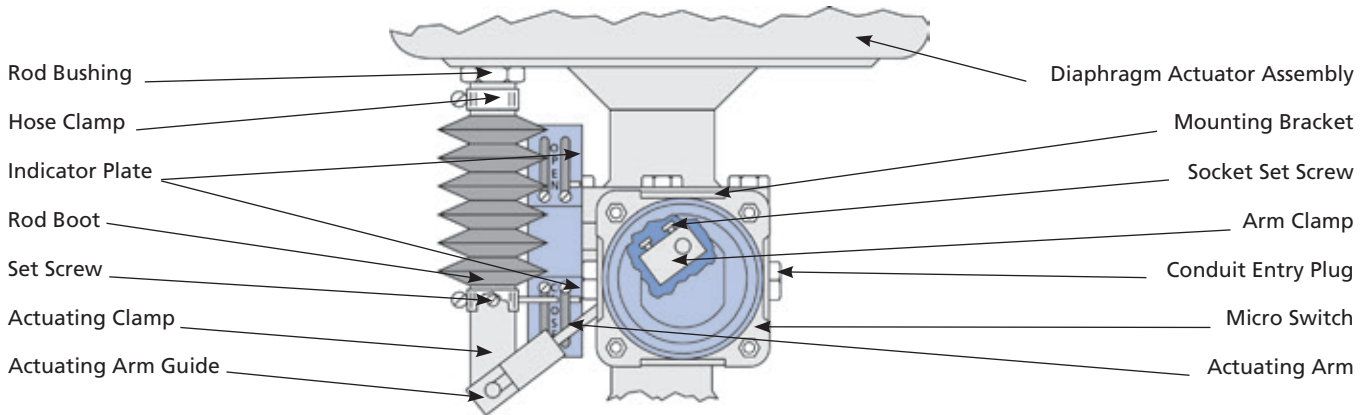

### Piston Actuators

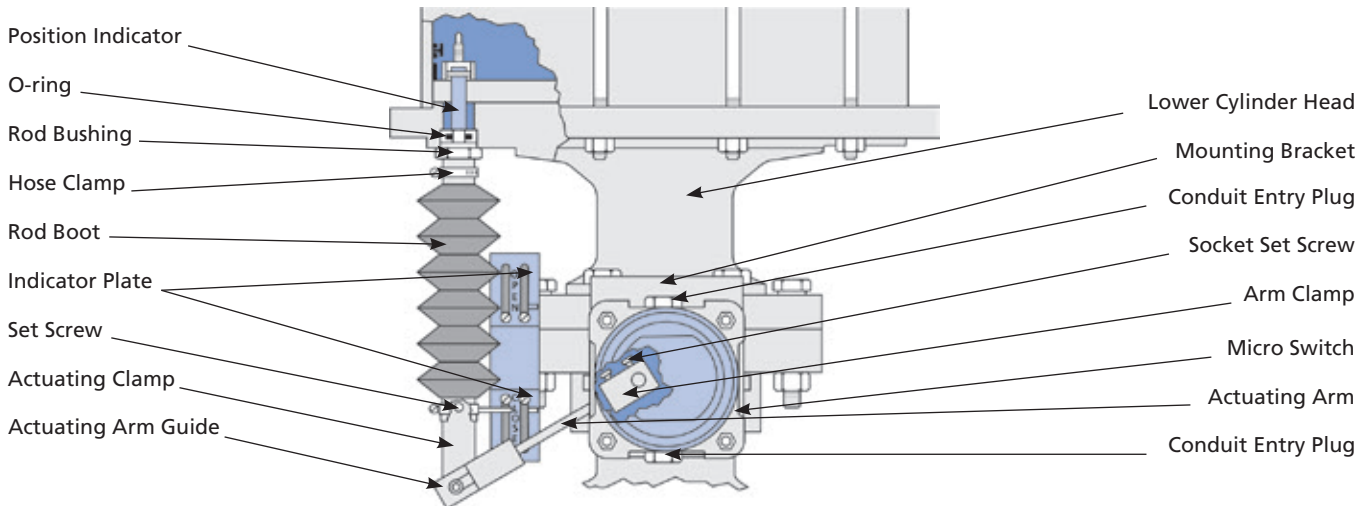

The Honeywell CX Micro Switch™ consists of a rugged cast-aluminum housing with threaded cover and is built especially for outdoor use in hazardous atmospheres.

CX switches are actuated by cams mounted on the shaft, and the cams are individually adjustable to actuate each switch element at any point in the stem travel. The CX switch is offered standard with two or four single-pole double-throw (SPDT) basic switches.

Only one conduit connection is required, and the switch elements are readily replaceable without disturbing the conduit. All the mounting screws are of generous size, so the switch is not vulnerable to being knocked or pulled out of position. The switches can be adjusted to operate as near to the end of travel as desired.

The CX switch is weather-tight, rugged, adjustable, repairable, and requires only one conduit connection for as many as four circuits. It is UL listed, CSA approved, NEMA classified as explosion-proof for hazardous locations, and is water-tight and dust-tight for outside service.

The electrical rating is 20 amps at 125 or 250 AC and 0.5 amps at 125 DC. Hermetically sealed basic switches rated for 1 amp at 120 V AC and NEMA 4X housings also are available.

Micro-valves, proximity switches, intrinsically safe sensors and other types of switches are available on request.



## PROXIMITY TYPE LIMIT SWITCHES FOR ORBIT VALVES AND ACTUATORS

### Diaphragm Actuators

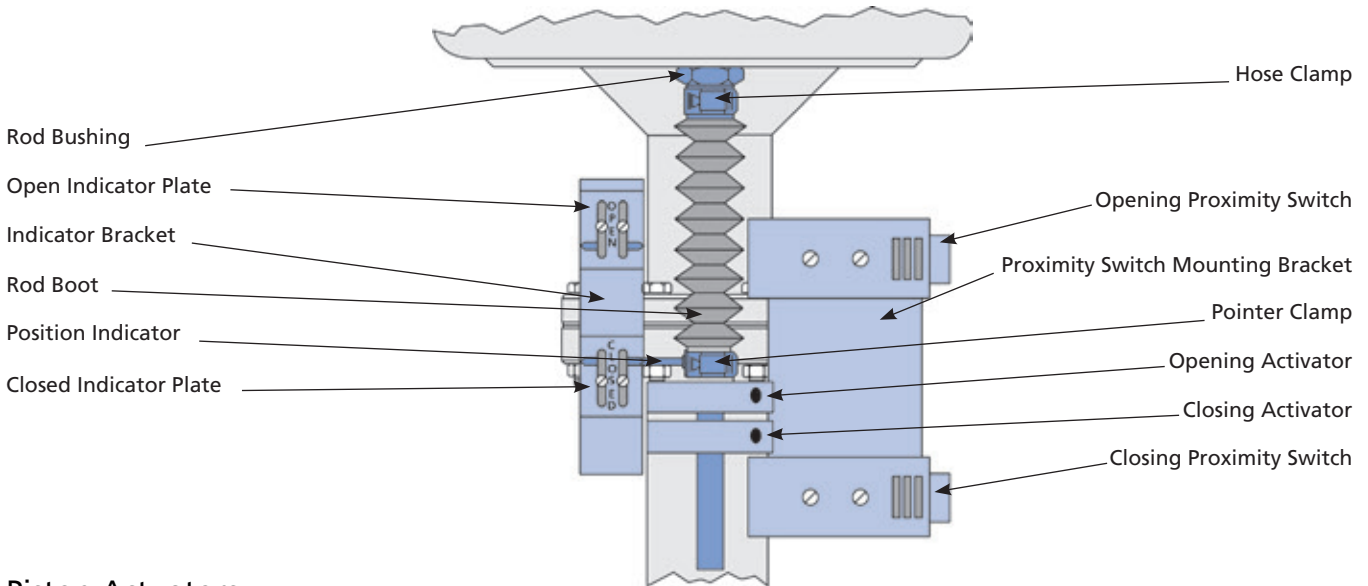

### Piston Actuators

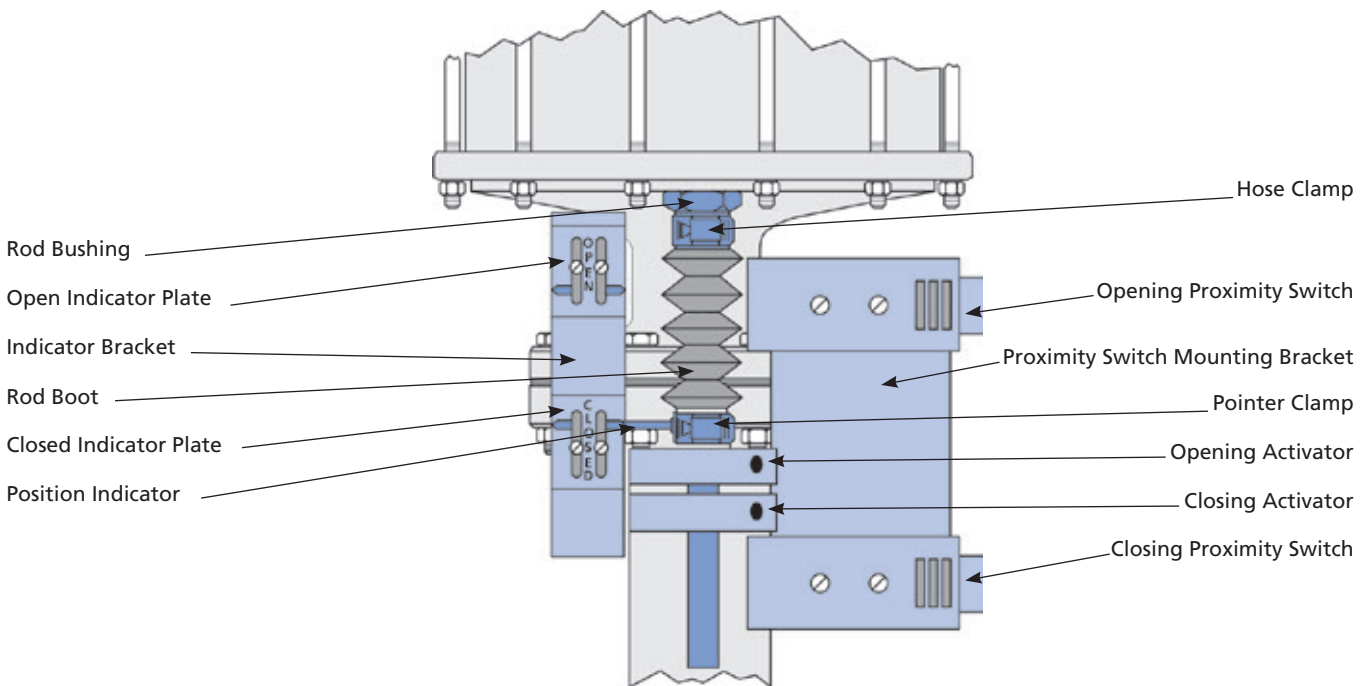

Proximity limit switches are available for both manual and automated ORBIT valves. They are totally enclosed, hermetically sealed switches and are available with brass or stainless steel housings for hazardous atmospheres. ORBIT valves' standard proximity switches include SPDT with brass or stainless steel housings, or double-pole, double-throw with stainless steel housings.

Standard assemblies include two switches; one for the valve open position and one for the valve's closed position. Commonly used switches are FM- and CSA-approved for Class 1, Division 1 hazardous locations. They are suitable for  $-40^{\circ}\text{F}$  to  $250^{\circ}\text{F}$  ( $-40^{\circ}\text{C}$  to  $121^{\circ}\text{C}$ ) temperature range and are rated for 10 amps at 125 V AC and 0.9 amps at 24 V DC.

## CAMSERV™ Aftermarket Services for Valves and Actuation

WE BUILD IT. WE BACK IT.



### Global Network and Local Support

Cameron is well-positioned to deliver total aftermarket support, quickly and efficiently, with unmatched OEM expertise. Our highly skilled engineers and technicians are available around the clock, seven days a week, to respond to customer queries, troubleshoot problems and offer reliable solutions.

### Easily Accessible Parts and Spare Valves

- OEM spare valves, actuators and parts (including non-Cameron brands)
- Handling, storage, packaging and delivery
- Dedicated stocking program

### Comprehensive Aftermarket Services Portfolio

- Parts and spare valves
- Repair
- Field services
- Preventative maintenance
- Equipment testing and diagnostics
- Remanufacturing
- Asset preservation
- Customer property management
- Training and recertification services
- Warranty

### Customized Total Valve Care<sup>SM</sup> (TVC) Programs

Customized asset management plans that optimize uptime, availability and dedicated services.

- Engineering consultancy
- Site management
- Flange management
- Startup and commissioning
- Spare parts and asset management





3250 Briarpark Drive, Suite 300  
Houston, TX 77042  
USA  
Toll Free 1 800 323 9160

For more information on ORBIT products:

[www.c-a-m.com/ORBIT](http://www.c-a-m.com/ORBIT)

[ORBIT@c-a-m.com](mailto:ORBIT@c-a-m.com)



#### **HSE Policy Statement**

At Cameron, we are committed ethically, financially and personally to a working environment where no one gets hurt and nothing gets harmed.