

Service
Service
Service

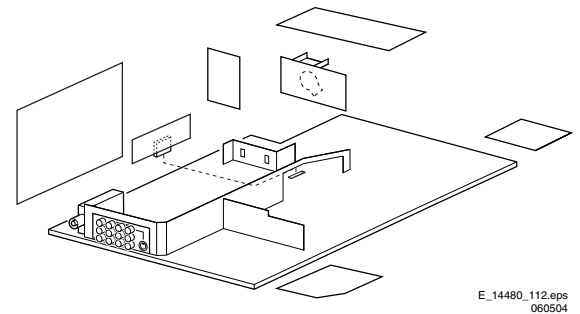

E_14480_112.eps
060504

Service Manual

Contents	Page
1. Technical Specifications, Connections, and Chassis Overview	2
2. Safety and Maintenance Instructions, Warnings, and Notes	4
3. Directions for Use	6
4. Mechanical Instructions	7
5. Service Modes, Error Codes, and Faultfinding	9
6. <i>Block Diagrams, Testpoint Overviews, and Waveforms</i>	
Wiring Diagram	21
Block Diagram Supply and Deflection	22
Testpoint Overview Mono Carrier	23
Block Diagram Video	24
Testpoint Overview CRT, LTI & PIP Panel	25
Block Diagram Audio/Control	26
I2C and Supply Voltage Overview	27
7. <i>Circuit Diagrams and PWB Layouts</i>	<i>Diagram PWB</i>
Power Supply (Diagram A1)	28 40-45
Diversity Table for A1 (Power Supply)	29 40-45
Deflection (Diagram A2)	30 40-45
Diversity Table for A2 (Deflection)	31 40-45
Tuner IF (Diagram A3)	32 40-45
Hercules (Diagram A4)	33 40-45
Features & Connectivities (Diagram A5)	34 40-45
Class D - Audio Amplifier (Diagram A6)	35 40-45
Audio Amplifier (Diagram A7)	36 40-45
Rear I/O Cinch (Diagram A8)	37 40-45
Front Control (Diagram A9)	38 40-45
DVD Power Supply (Reserved) (Diagram A10)	39 40-45
CRT Panel (Diagram B1)	46 48-49
ECO Scavem Panel (Diagram B2)	47 48-49
Side AV + HP Panel (PV2) (Diagram D)	50 51
Side AV + HP Panel (FL-9) (Diagram D)	52 53
Top Control Panel (PV2) (Diagram E)	54 54

Contents	Page
Top Control Panel (FL9) (Diagram E)	55 55
Power Supply PIP Panel (Diagram F1)	56 58-59
Tuner IF and Demodulator PIP (Diagram F2)	57 58-59
Linearity & Panorama Panel (Diagram G)	60 60
LTI/CTI Interface Panel (Diagram H)	61 62
Front Interface Panel (PV2) (Diagram J)	63 63
Front Interface Panel (FL-9) (Diagram J)	64 64
8. Alignments	65
9. Circuit Descriptions	73
Abbreviation List	82
IC Data Sheets	84
10 Spare Parts List	86
11 Revision List	90

©Copyright 2004 Philips Consumer Electronics B.V. Eindhoven, The Netherlands.
All rights reserved. No part of this publication may be reproduced, stored in a retrieval system or transmitted, in any form or by any means, electronic, mechanical, photocopying, or otherwise without the prior permission of Philips.



Block Diagram Supply and Deflection

SUPPLY AND DEFLECTION

SUPPLY

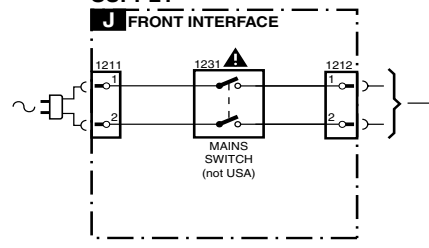

A1 POWER SUPPLY

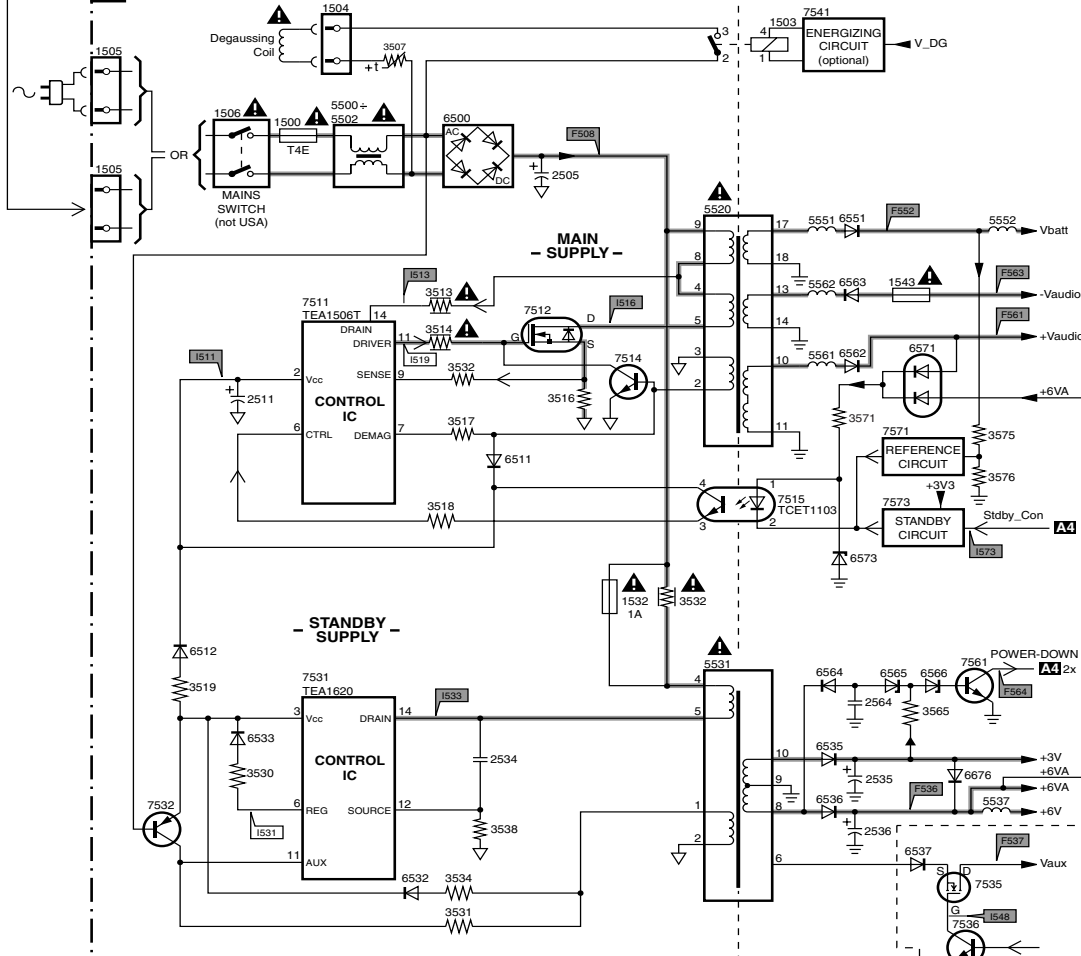

- F508 268V / div DC
- F511 15V5 / div DC
- F531 2V7 / div DC
- F537 0V (N.A.)
- F552 130V / div DC
- F561 15V9 / div DC
- F564 9V4 / div DC
- F573 0V (N.A.)

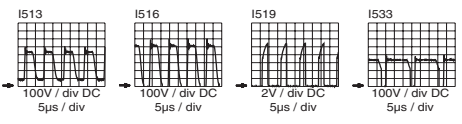

DEFLECTION

A4 HERCULES

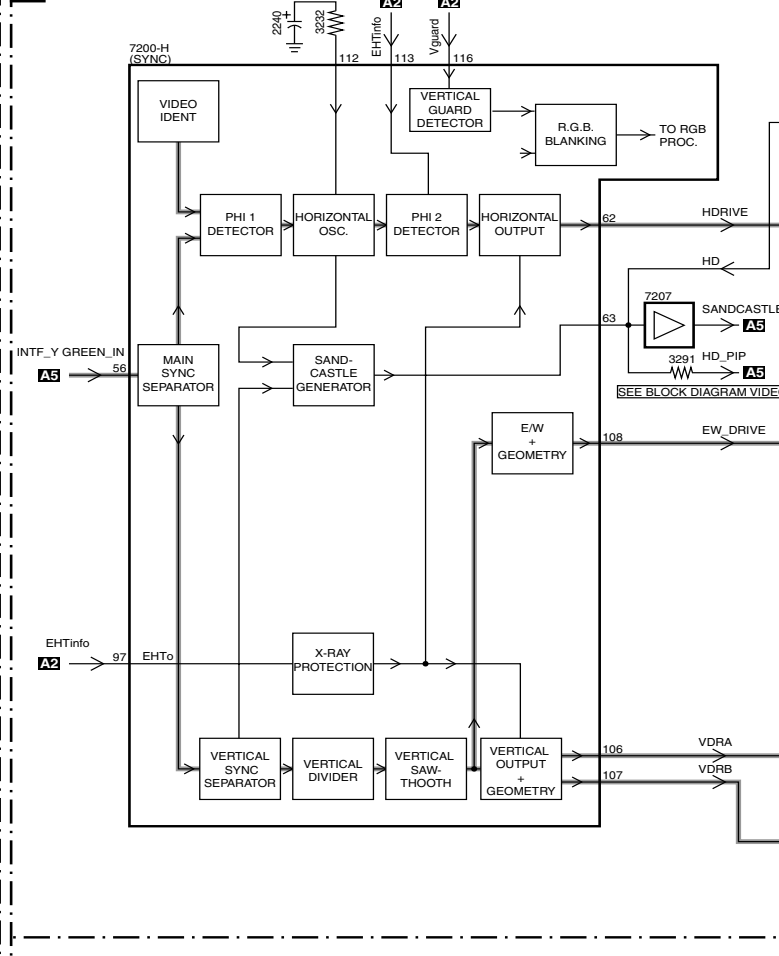

- F401 130V / div DC
- F402 32V8 / div DC
- F412 2V / div DC 20µs / div
- F414 200V / div DC 20µs / div
- F418 5V / div DC 20µs / div
- F452 -13V4 / div DC
- F453 190V8 / div DC

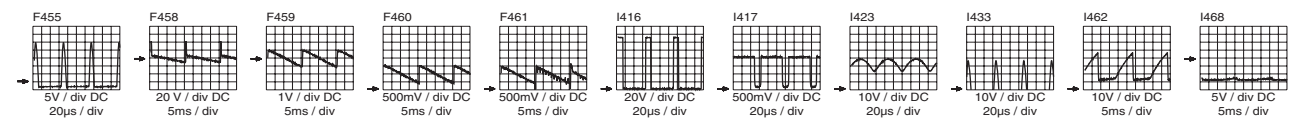

A2 LINE + FRAME DEFLECTION

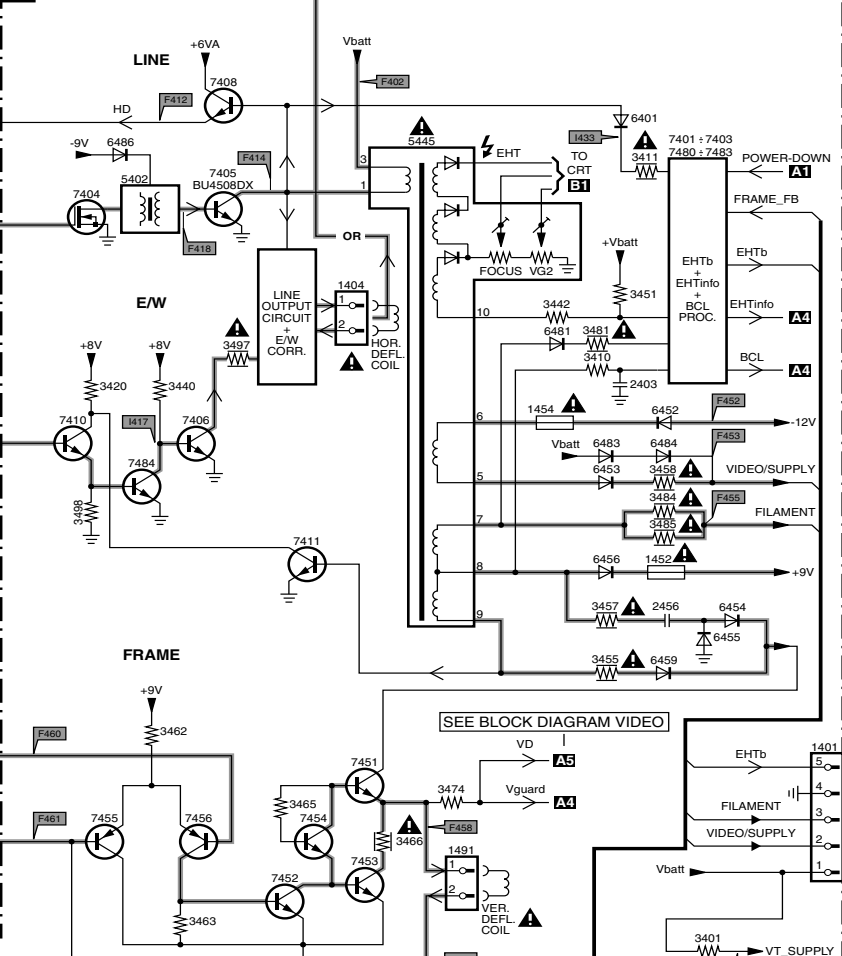

C LINEARITY & PANORAMA

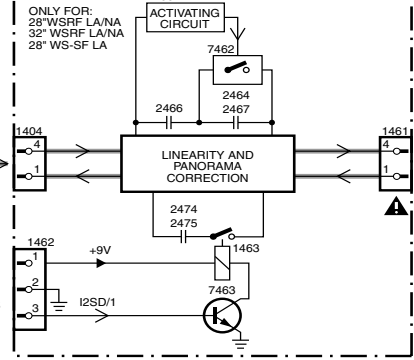

Block Diagram Video

VIDEO

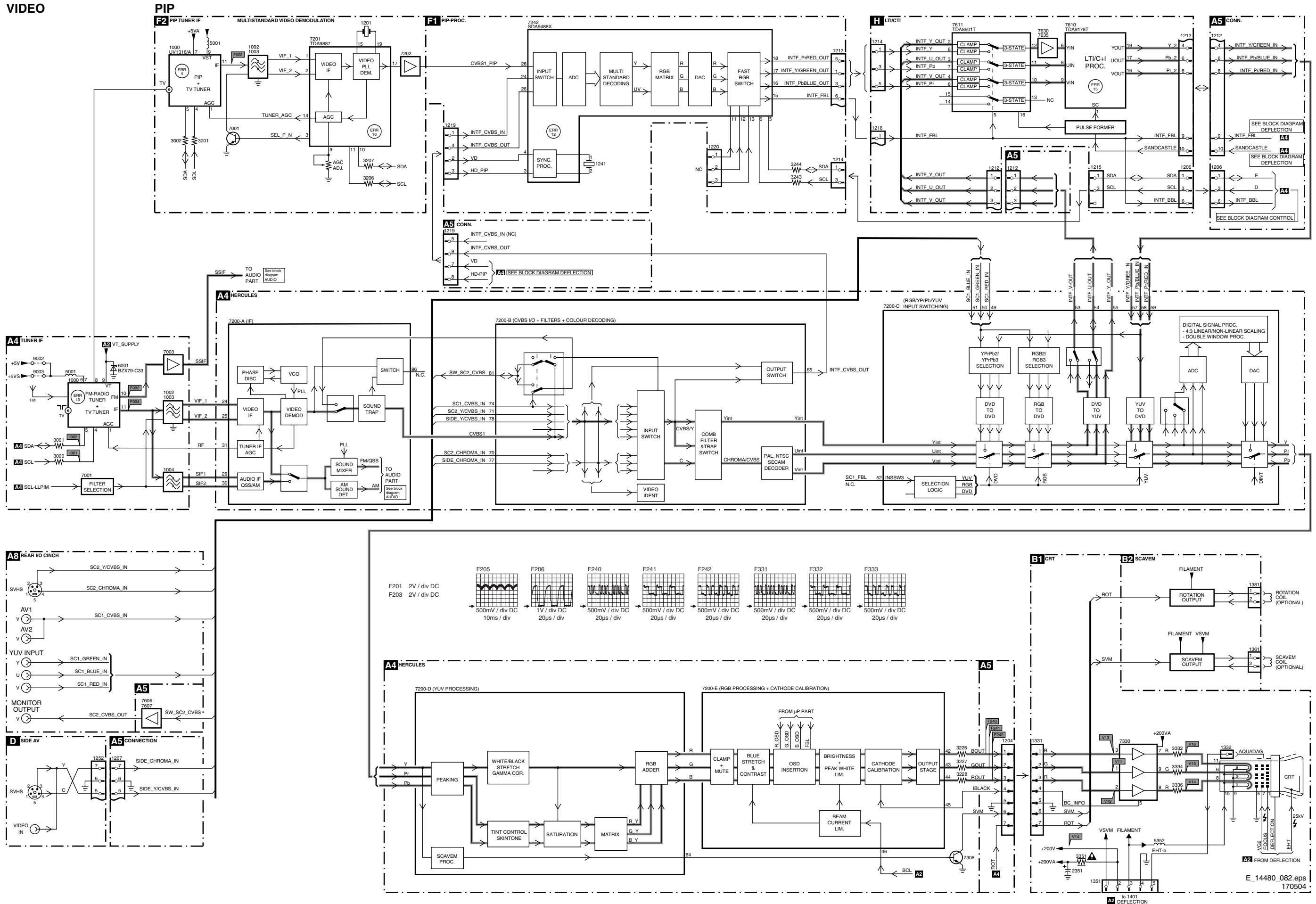

Block Diagram Audio/Control

AUDIO

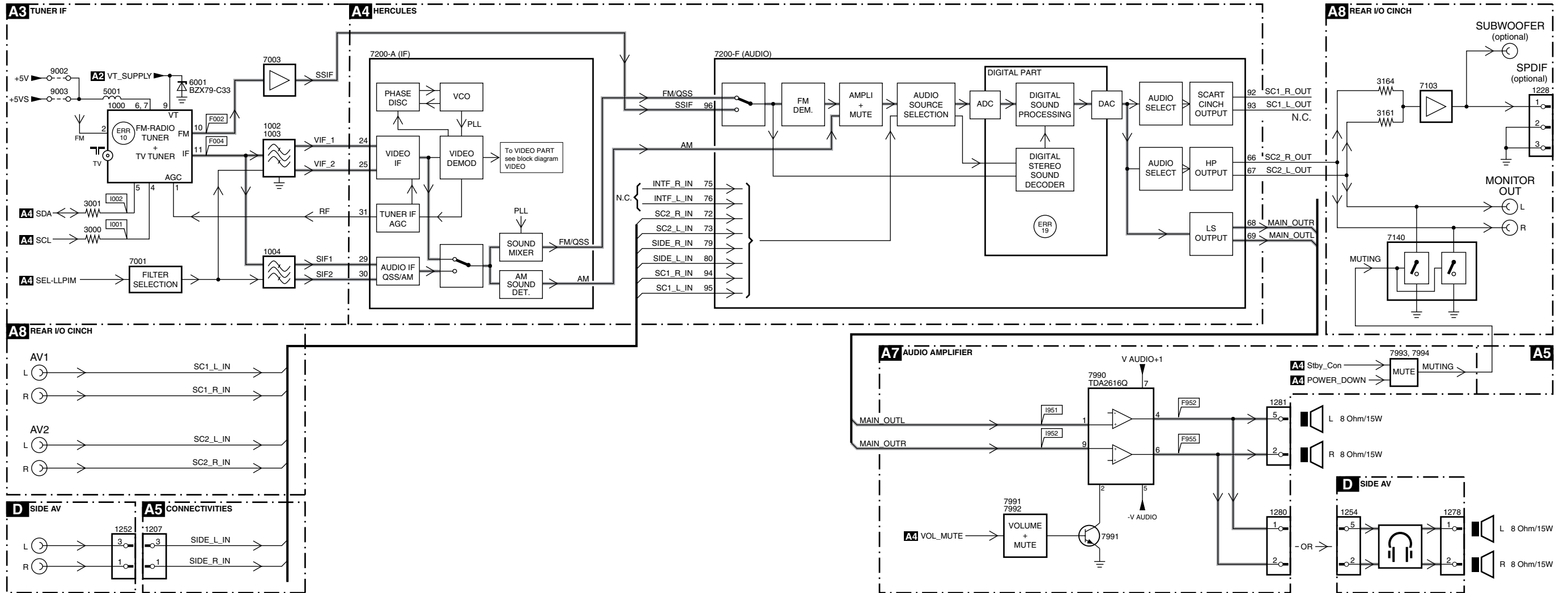

CONTROL

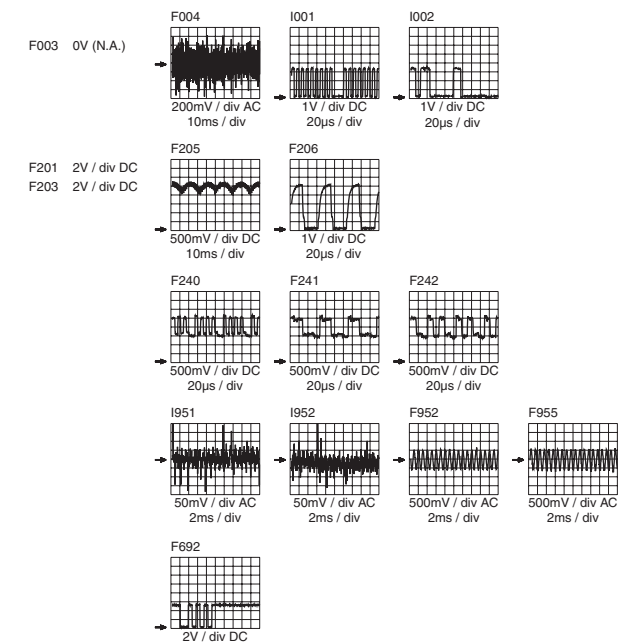
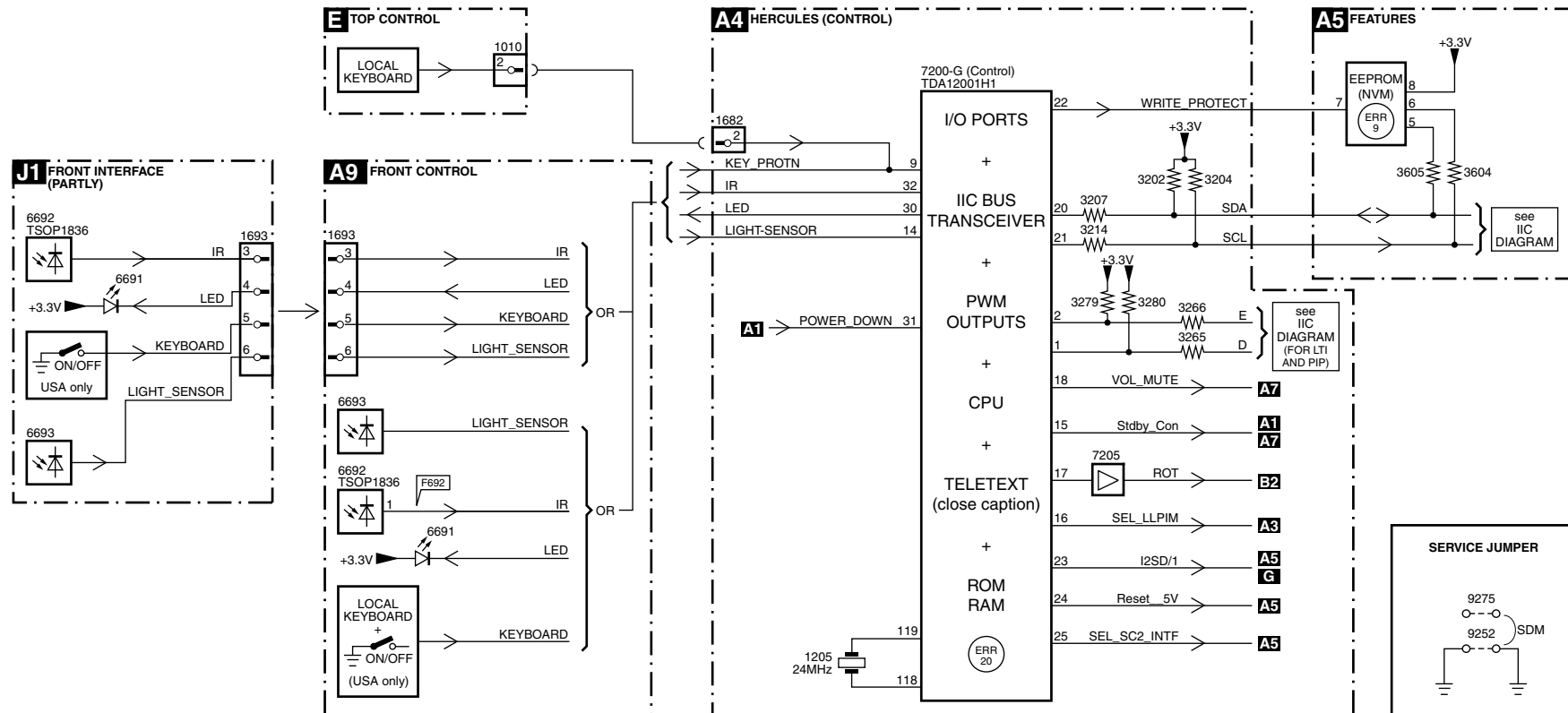

I2C and Supply Voltage Overview

SUPPLY LINES DIAGRAM

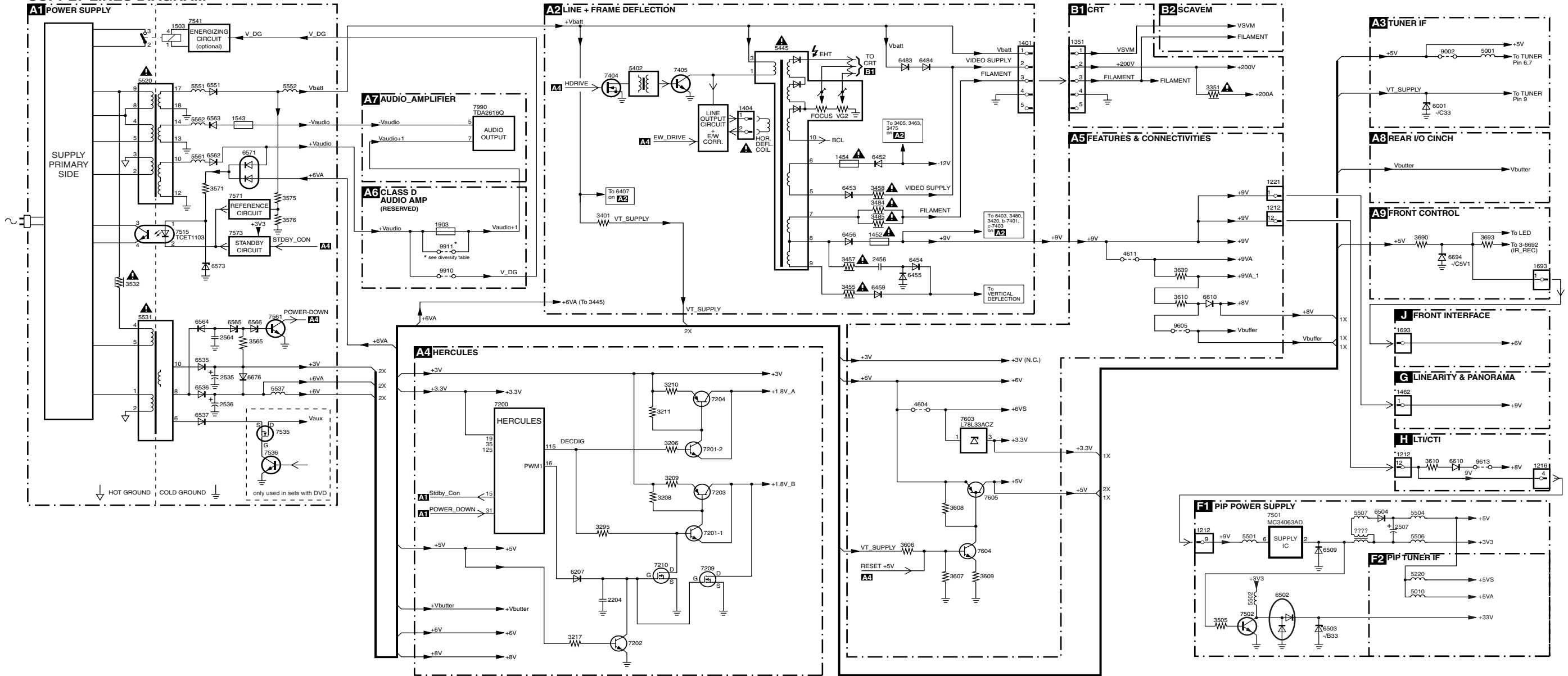

I2C BUS INTERCONNECTION DIAGRAM

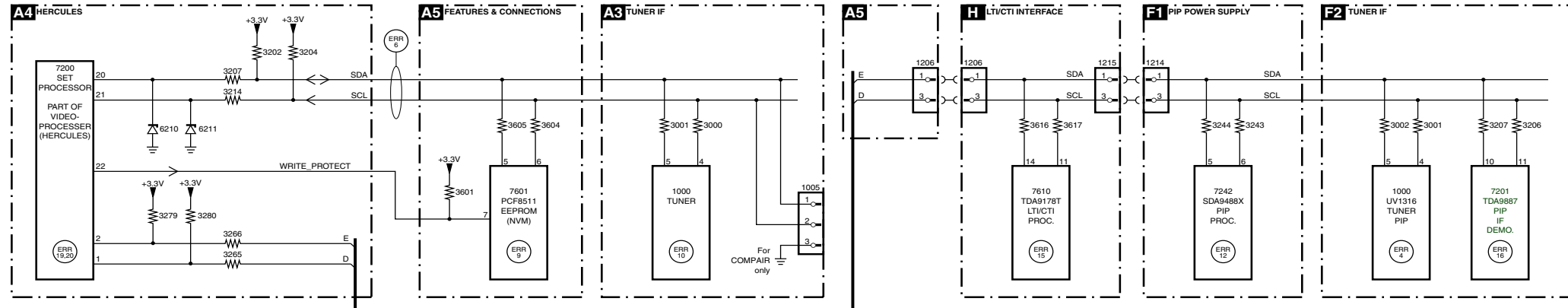

ERROR CODE LIST

ERROR	Device	Error description	Check Item	Diagram
0	Not applicable	No Error		
1	Not applicable	X-Ray / over-voltage protection (US only)	2411, 2412, 2413, 6404, 6411, 6412	A2
2	Not applicable	High beam (BCI) protection	3404, 7405	A2
3	Not applicable	Vertical guard protection	3446, 7451, 7452, 7453, 7454	A2
4	Tuner UA1316/A	I ² C error while communicating with 2nd tuner	1000, 5010 (PIP Module)	F2
5	Not applicable	-5v protection	7604, 7605	A5
6	Not applicable	General I ² C error	7200, 3207, 3214	A4
7	Not applicable	-	-	-
8	Not applicable	-	-	-
9	Not applicable	I ² C error while communicating with the EEPROM	7601, 3604, 3605	A5
10	Tuner	I ² C error while communicating with the PLL tuner	1000, 5001	A3
11	TDA6107/A	Black current loop instability protection	7330, 3351, CRT	B1
12	SDA9488X	I ² C error while communicating with the PIP processor	7242 (PIP Module)	F1
13	Not applicable	-	-	-
14	DVD Loader	I ² C error while communicating with the DVD Interface module	DVD Interface module	DVD Loader
15	TDA9178T/N1	I ² C error while communicating with LTI module	7610	H
16	TDA9887	I ² C error while communicating with PIP Demodulator	7201	F2
17	Not applicable	-	-	-
18	Not applicable	-	-	-
19	TDA1200	I ² C error while communicating with SSD stereo sound decoder	7200	A4
20	TDA1200	I ² C error while communicating with video cosmic in Hercules IC	7200	A4

7. Circuit Diagrams and PWB Layouts

Mono Carrier: Power Supply

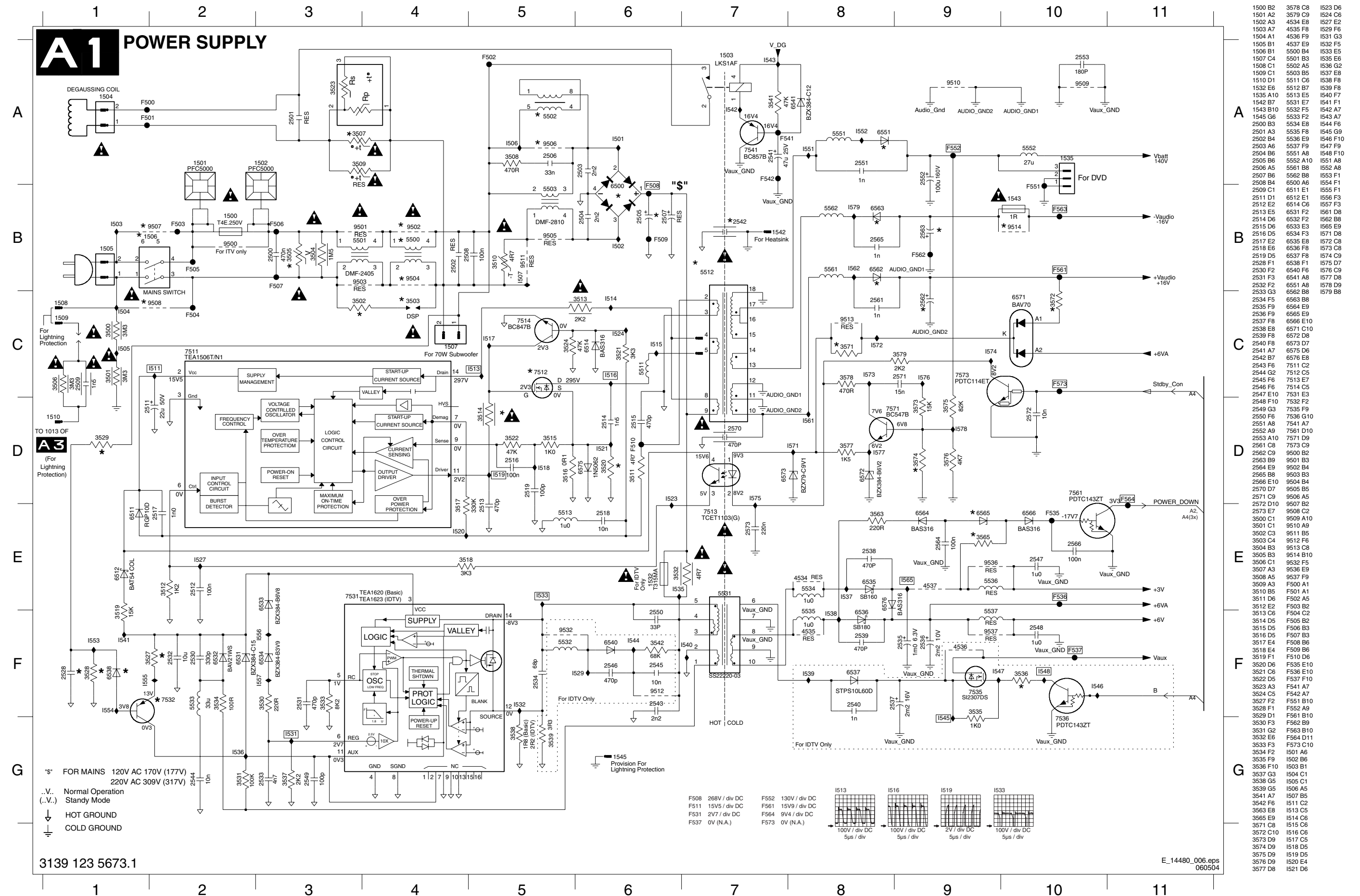

Mono Carrier: Deflection

A2 LINE + FRAME DEFLECTION

From LOT 5450
(For A80ERF042X14
Tube Only)

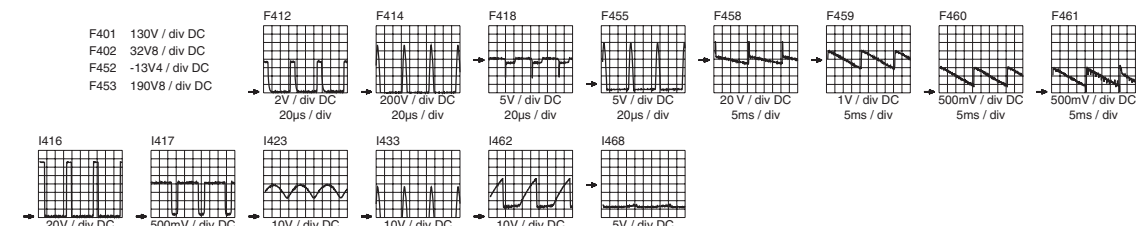
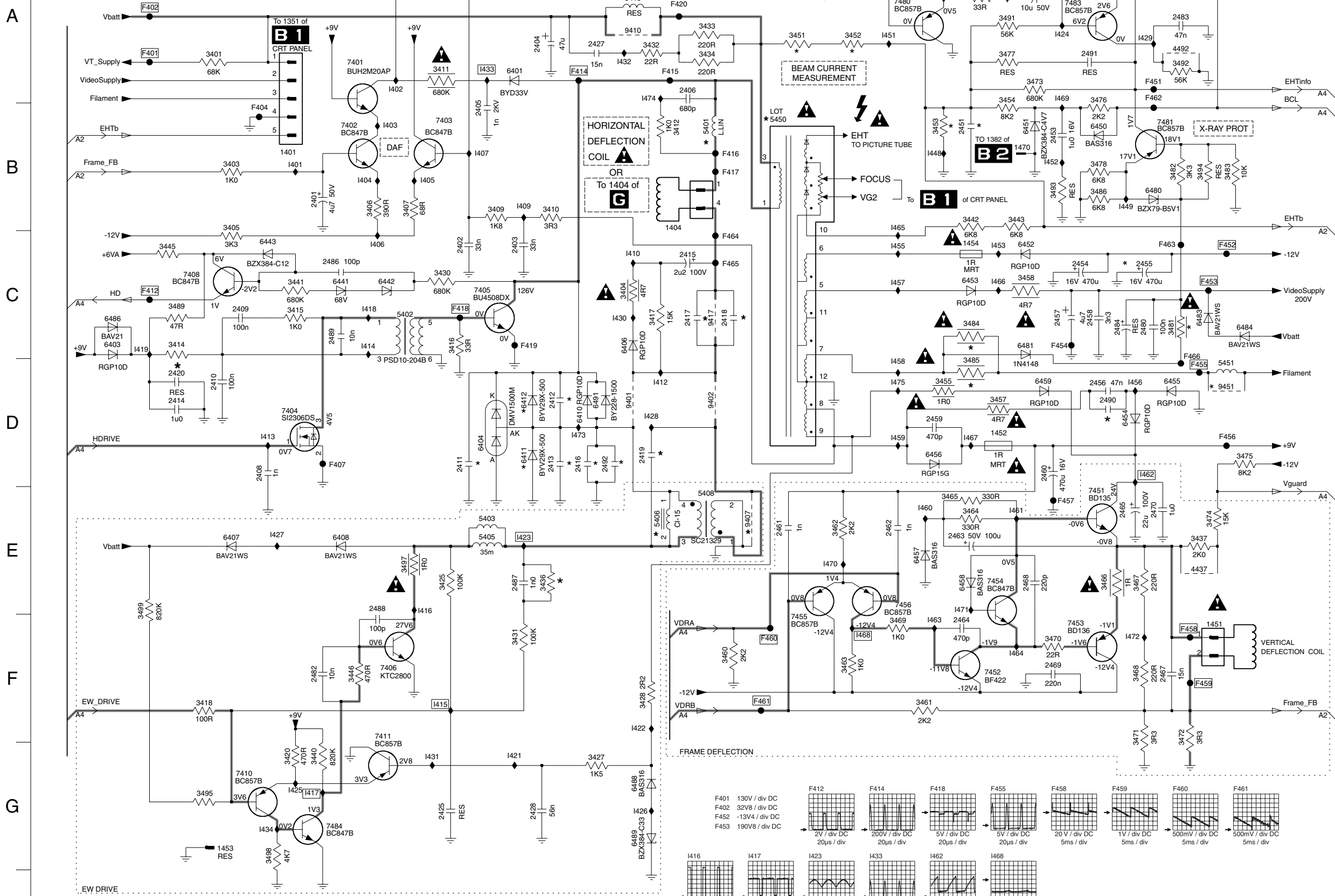

1401 B2	5451 D10
1402 A3	6401 A4
1404 B5	6403 C1
1451 F9	6404 D4
1452 D8	6406 C5
1453 G2	6407 E2
1454 C8	6408 E3
1470 B8	6410 D5
2401 B3	6411 D4
2402 C4	6412 D4
2403 C4	6441 C3
2404 A4	6442 C3
2405 B4	6443 C2
2406 A5	6450 B9
2408 D2	6451 B8
2409 C2	6452 C8
2410 D2	6453 C8
2411 D4	6454 D9
2412 D4	6455 D9
2413 C4	6456 D7
2414 D1	6457 E7
2415 C5	6458 E8
2416 D5	6459 D8
2417 C5	6460 B9
2418 C6	6481 C8
2419 D5	6482 A10
2420 D1	6483 C9
2425 G4	6484 C10
2427 A5	6486 C1
2428 G4	6488 G5
2451 B8	6489 G5
2452 C9	7401 A3
2454 C9	7401 A3
2455 C9	7402 B3
2456 D9	7403 B4
2457 C8	7404 D2
2458 C9	7405 C4
2459 D7	7406 F3
2460 D8	7408 C2
2461 E5	7410 D2
2462 E7	7411 F3
2463 E8	7451 E9
2464 F8	7452 F8
2465 E9	7453 F8
2467 F9	7454 E8
2468 E8	7455 E6
2469 F8	7456 E7
2470 E9	7480 A7
2480 C9	7481 B9
2481 A8	7482 A9
2482 F3	7483 A8
2483 A9	7484 G3
2484 C9	9401 D5
2486 C3	9402 D6
2487 E4	9407 E6
2488 E3	9410 A5
2489 C3	9411 C5
2490 D9	9451 D10
2491 A9	F401 A1
2492 D5	F402 A1
3401 A2	F404 B2
3403 B2	F407 D3
3404 C5	F412 C1
3405 B2	F414 A5
3406 B3	F415 A5
3407 B3	F416 B6
3409 B4	F417 B6
3410 B4	F418 C4
3411 A4	F419 C4
3412 B5	F420 A5
3414 C1	F451 A9
3415 C2	F452 C10
3416 C3	F453 C10
3417 C5	F454 C8
3418 F2	F455 D9
3420 G2	F456 D10
3425 E4	F457 E8
3427 G5	F458 F9
3428 F5	F459 F9
3430 C4	F460 F6
3431 F4	F461 F6
3432 E5	F462 A9
3433 A6	F463 C9
3434 A6	F464 C6
3436 E4	F465 C6
3437 E9	F466 D9
3440 G3	I401 B2
3441 C2	I402 A3
3442 B8	I403 B3
3443 B8	I404 B3
3445 C1	I405 B3
3446 F3	I406 C3
3451 A6	I407 B4
3452 A7	I409 B4
3453 B7	I410 C5
3454 A8	I412 D5
3455 D7	I413 D2
3457 D8	I414 C3
3458 C8	I415 F3
3460 F6	I416 E3
3461 F7	I417 G2
3462 E7	I418 C3
3463 F7	I419 C1
3464 E8	I421 G4
3465 E7	I422 F5
3466 E8	I423 E2
3467 E9	I424 A8
3468 F9	I425 G2
3469 F7	I426 G5
3470 F8	I427 E2
3471 F9	I428 D5
3472 F9	I429 A9
3473 A8	I430 C5
3474 E10	I431 C3
3475 D10	I432 A5
3476 A9	I433 A4
3477 A8	I434 G2
3478 B9	I437 A7
3480 A7	I444 A7
3481 C9	I445 A8
3482 B9	I446 A9
3483 B10	I448 B7
3484 C8	I449 B9
3485 D8	I451 A7
3486 B9	I452 B8
3487 A8	I453 C8
3488 A7	I455 C7
3489 C1	I456 D9
3490 A8	I457 C7
3491 A8	I458 D7
3492 A9	I459 D7
3493 B8	I460 E7
3494 B9	I461 E8
3495 G2	I462 D9
3497 E3	I463 F7
3498 G2	I464 F8
3499 E1	I465 B7
4437 E9	I466 C8
4492 A9	I467 D8
5401 B6	I468 F7
5402 C3	I469 A8
5403 E4	I470 E7
5405 E4	I471 E8
5406 E5	I472 F9
5408 E6	I473 D5
5410 A5	I474 A5
5450 B6	I475 D7

3139 123 5673.1

E_14480_007.eps
170504

Mono Carrier: Tuner IF

A3 TUNER IF

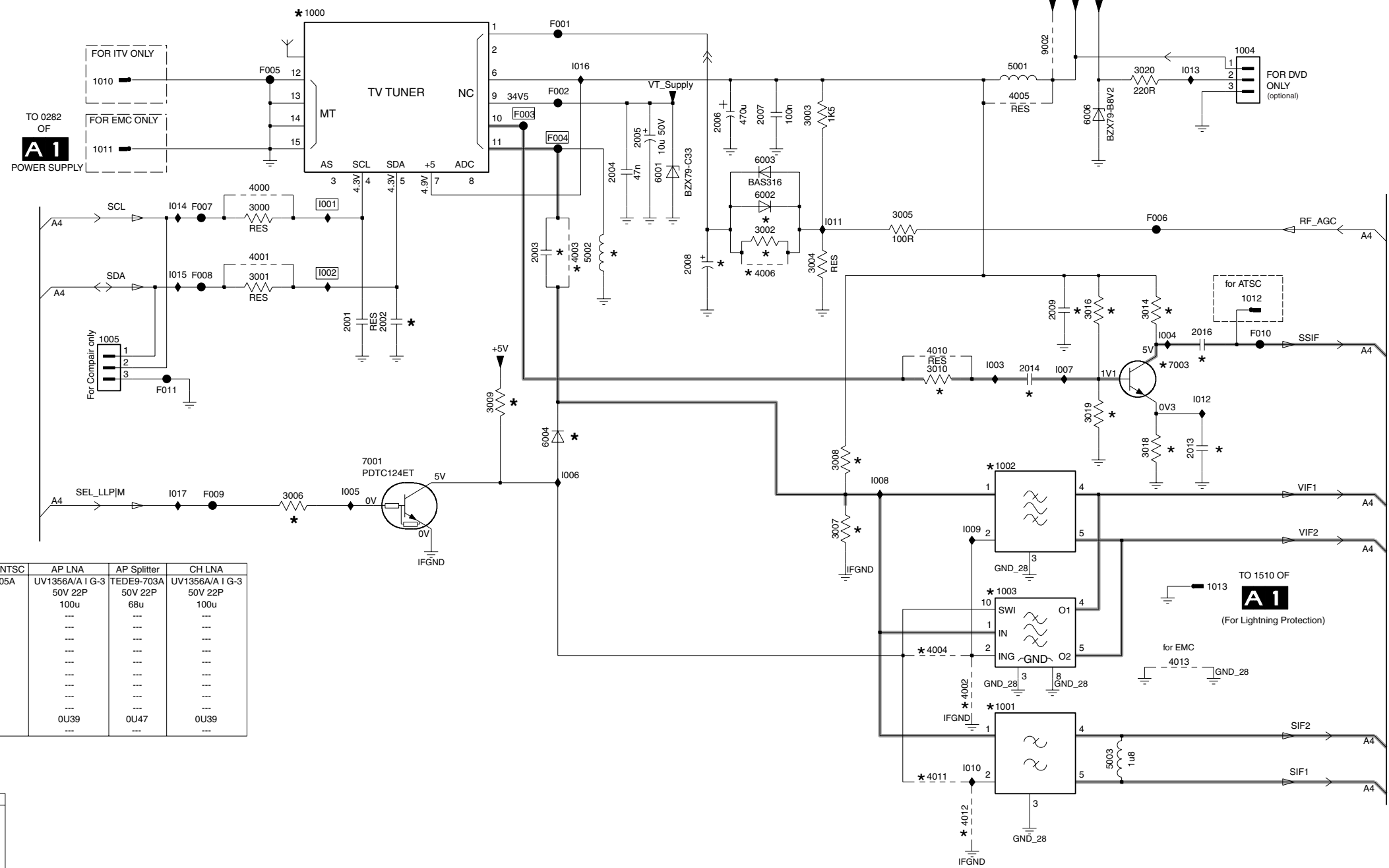

ITEM	EU Normal	EU FM Radio	EU Splitter	NA/LA/AP NTSC	AP LNA	AP Splitter	CH LNA
1000	UV1316E/A 1-4	UR1316/A 1-3	TEDE9-703A	TEDH9-305A	UV1356A/A 1 G-3	TEDE9-703A	UV1356A/A 1 G-3
2002	50V 22P	50V 22P	50V 22P	---	50V 22P	50V 22P	50V 22P
2008	68u	68u	68u	100u	100u	68u	100u
2009	---	16V 100N	---	---	---	---	---
2013	---	25V 1N	---	---	---	---	---
2014	---	25V 1N	---	---	---	---	---
2016	---	25V 1N	---	---	---	---	---
3010	---	330R	---	---	---	---	---
3014	---	820R	---	---	---	---	---
3016	---	100K	---	---	---	---	---
3018	---	560R	---	---	---	---	---
3019	---	150K	---	---	---	---	---
5002	0U47	0U47	0U47	0U39	0U39	0U47	0U39
7003	---	BFS20	---	---	---	---	---

ITEM	EU-QSS	NA/LA/AP INT	AP QSS	CH QSS
1001	K9656M	---	K9362M	K9352M
1002	K3953M	M1971M	K7257M	---
1003	---	---	---	K6274M
2003	50V 10N	---	50V 10N	50V 10N
3002	10K	---	---	---
3006	10K	---	10K	10K
3007	2K2	---	2K2	2K2
3008	6K8	---	6K8	6K8
3009	2K2	---	2K2	2K2
4002	JMP	JMP	---	JMP
4003	---	JMP	---	JMP
4004	---	JMP	JMP	JMP
4006	---	JMP	JMP	JMP
4011	JMP	---	---	JMP
4012	---	---	JMP	JMP
6002	BAS316	---	1SS356	1SS356
6004	1SS356	---	1SS356	1SS356
7001	PDTC124ET	---	PDTC124ET	PDTC124ET

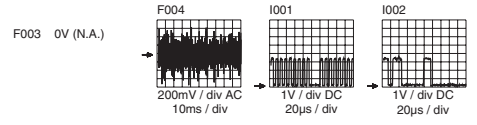

- 1000 A4
- 1001 E8
- 1002 D8
- 1003 D8
- 1004 A10
- 1005 C3
- 1010 A3
- 1011 B3
- 1012 C10
- 1013 D10
- 2001 C4
- 2002 C4
- 2003 B5
- 2004 B6
- 2005 B6
- 2006 A6
- 2007 A7
- 2008 B6
- 2009 C9
- 2013 C9
- 2014 C8
- 2016 C9
- 3000 B4
- 3001 B4
- 3002 B7
- 3003 A7
- 3004 B7
- 3005 B8
- 3006 D4
- 3007 D7
- 3008 D7
- 3009 C5
- 3010 C8
- 3014 C9
- 3016 C9
- 3018 C9
- 3019 C9
- 3020 A9
- 4000 B4
- 4001 B4
- 4002 E8
- 4003 B6
- 4004 E8
- 4005 A8
- 4006 B7
- 4010 C8
- 4011 E8
- 4012 F8
- 4013 E9
- 5001 A8
- 5002 B6
- 5003 E9
- 6001 B6
- 6002 B7
- 6003 B7
- 6004 C5
- 6006 A9
- 7001 D4
- 7003 C9
- 9002 A8
- F001 A5
- F002 A5
- F003 A5
- F004 B5
- F005 A4
- F006 B9
- F007 B3
- F008 B3
- F009 D3
- F010 C10
- F011 C3
- I001 B4
- I002 B4
- I003 C8
- I004 C9
- I005 D4
- I006 D6
- I007 C9
- I008 D7
- I009 D8
- I010 E8
- I011 B7
- I012 C9
- I013 A9
- I014 B3
- I015 B3
- I016 A6
- I017 D3

Mono Carrier: Hercules

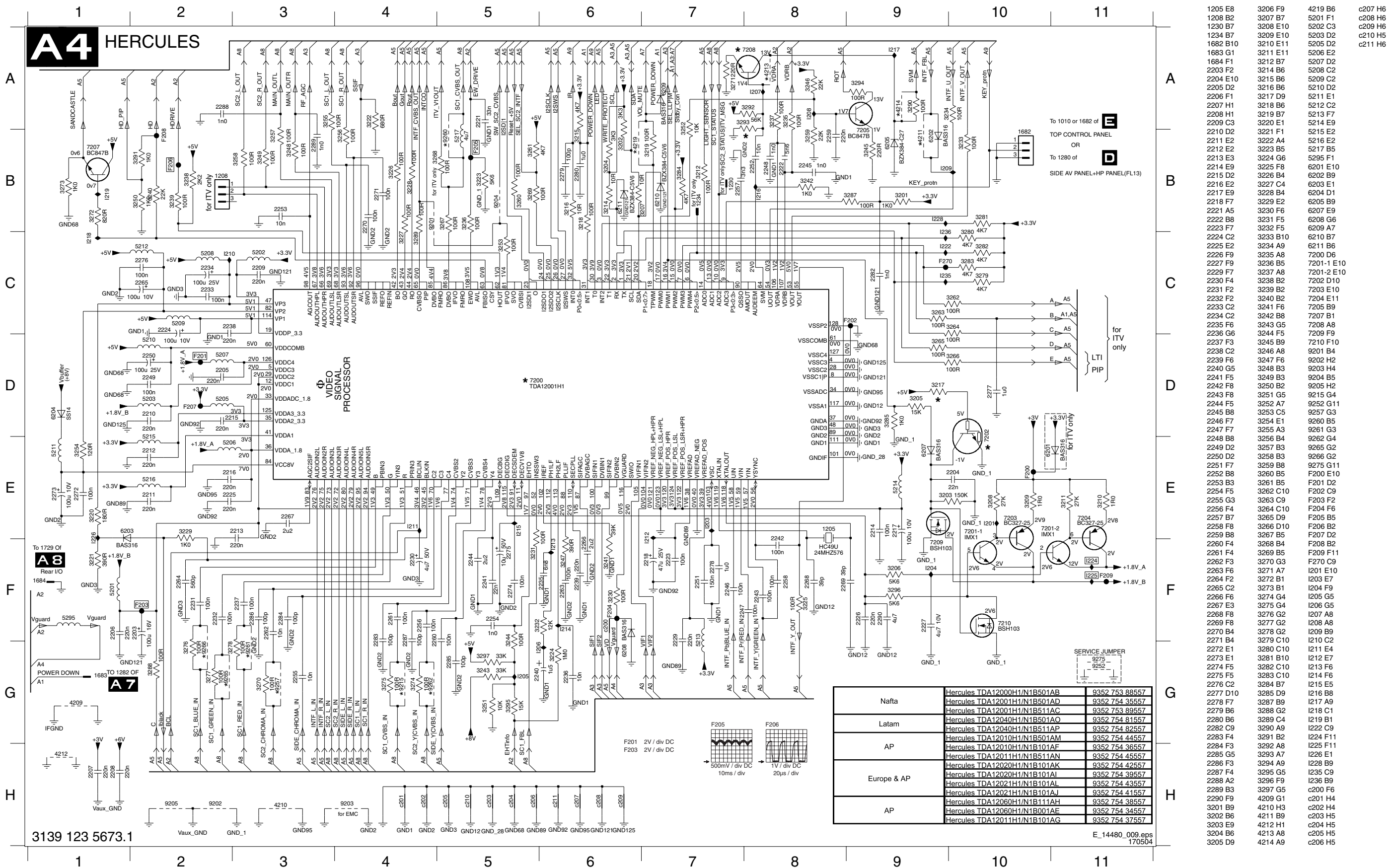

Mono Carrier: Features & Connectivities

A5 FEATURES & CONNECTIVITIES

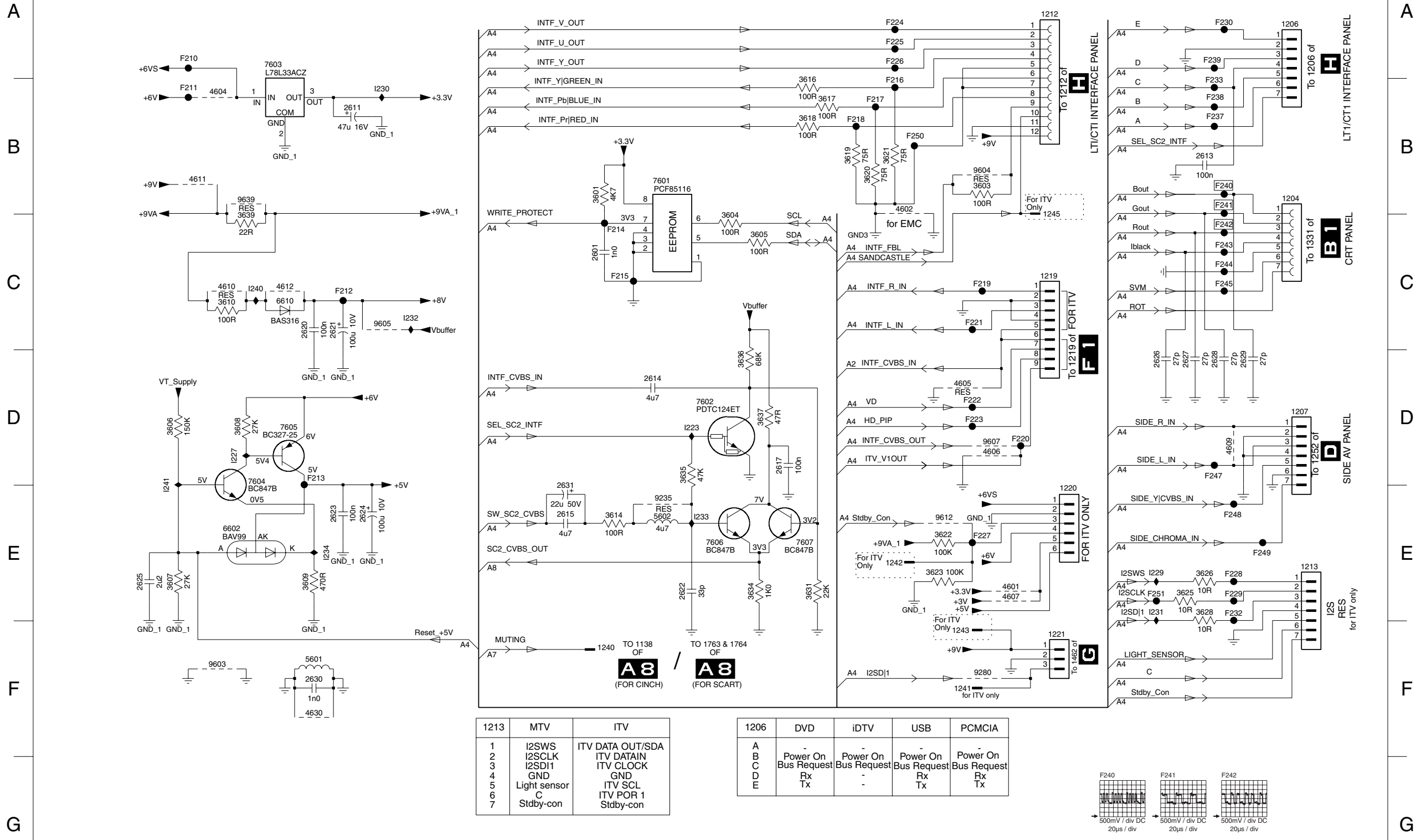

1213	MTV	ITV
1	I2SWS	ITV DATA OUT/SDA
2	I2SCLK	ITV DATAIN
3	I2SDI1	ITV CLOCK
4	GND	GND
5	Light sensor	ITV SCL
6	C	ITV POR 1
7	Stdby-con	Stdby-con

1206	DVD	iDTV	USB	PCMCIA
A	-	-	-	-
B	Power On	Power On	Power On	Power On
C	Bus Request	Bus Request	Bus Request	Bus Request
D	Rx	-	Rx	Rx
E	Tx	-	Tx	Tx

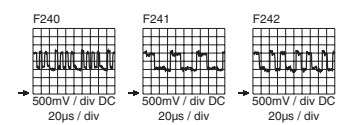

- 1204 B9
- 1206 A9
- 1207 D9
- 1212 A7
- 1213 E9
- 1219 C8
- 1220 E8
- 1221 F8
- 1240 F4
- 1241 F7
- 1242 E6
- 1243 F7
- 1245 C7
- 2601 C4
- 2611 B2
- 2613 B9
- 2614 D5
- 2615 E4
- 2617 D6
- 2620 C2
- 2621 C2
- 2622 E5
- 2623 E2
- 2624 E2
- 2625 E1
- 2626 D8
- 2627 D9
- 2628 D9
- 2629 D9
- 2630 F2
- 2631 E4
- 3601 B4
- 3603 B7
- 3604 C5
- 3605 C5
- 3606 D1
- 3607 E1
- 3608 D2
- 3609 E2
- 3610 C1
- 3614 E4
- 3616 B6
- 3617 B6
- 3618 B6
- 3619 B6
- 3620 B6
- 3621 B6
- 3622 E7
- 3623 E7
- 3625 E9
- 3626 E9
- 3628 E9
- 3631 E6
- 3634 E5
- 3635 D5
- 3636 D5
- 3637 D5
- 3639 C2
- 4601 E7
- 4602 B6
- 4604 B1
- 4605 D7
- 4606 D7
- 4607 E7
- 4609 D9
- 4610 C1
- 4611 B1
- 4612 C2
- 4630 F2
- 5601 F2
- 5602 E5
- 6602 E1
- 6610 C2
- 7601 B5
- 7602 D5
- 7603 A2
- 7604 D2
- 7605 D2
- 7606 E5
- 7607 E6
- 9235 E5
- 9280 F7
- 9603 F1
- 9604 B7
- 9605 C3
- 9607 D7
- 9612 E7
- 9639 B2
- F210 A1
- F211 B1
- F212 C2
- F213 D2
- F214 C4
- F215 C4
- F216 B6
- F217 B6
- F218 B6
- F219 C7
- F220 D7
- F221 C7
- F222 D7
- F223 D7
- F224 A6
- F225 A6
- F226 A6
- F227 E7
- F228 E9
- F229 E9
- F230 A9
- F232 E9
- F233 B9
- F237 B9
- F238 B9
- F239 B9
- F240 B9
- F241 B9
- F242 C9
- F243 C9
- F244 C9
- F245 C9
- F247 D9
- F249 E9
- F250 B7
- F251 E8
- I223 D5
- I227 D1
- I229 E8
- I230 B3
- I231 E8
- I232 C3
- I233 E5
- I234 E2
- I240 C2
- I241 D1

Mono Carrier: Audio Amplifier

A7 AUDIO_AMPLIFIER

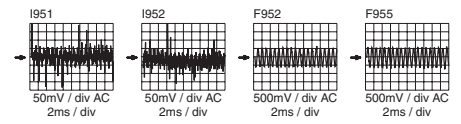
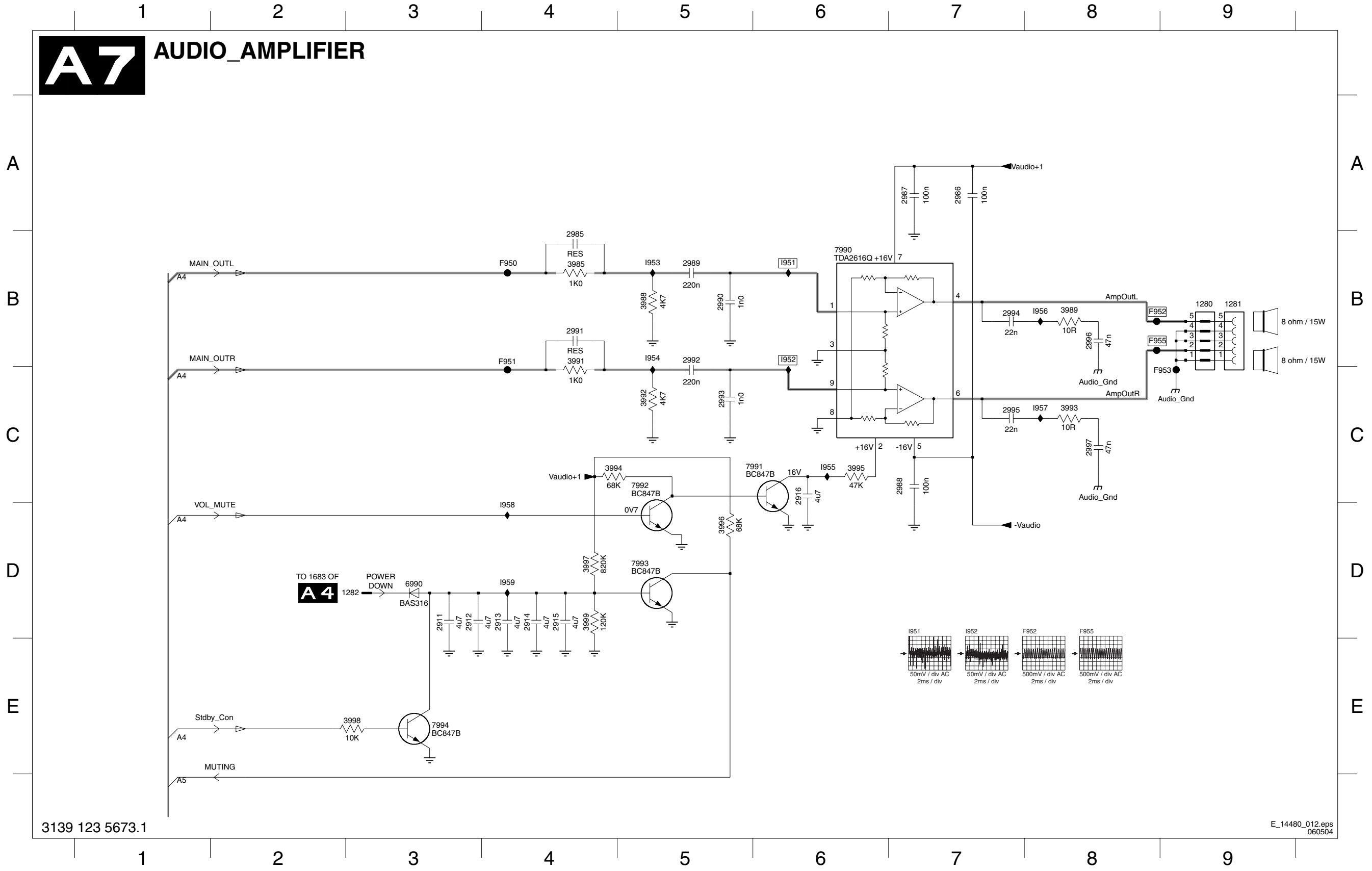

- 1280 B9
- 1281 B9
- 1282 D3
- 2911 D3
- 2912 D3
- 2913 D4
- 2914 D4
- 2915 D4
- 2916 C6
- 2985 B4
- 2986 A7
- 2987 A7
- 2988 C7
- 2989 B5
- 2990 B5
- 2991 B4
- 2992 B5
- 2993 C5
- 2994 B7
- 2995 C7
- 2996 B8
- 2997 C8
- 3985 B4
- 3988 B5
- 3989 B8
- 3991 B4
- 3992 C5
- 3993 C8
- 3994 C4
- 3995 C6
- 3996 D5
- 3997 D4
- 3998 E3
- 3999 D4
- 6990 D3
- 7990 B6
- 7991 C6
- 7992 C5
- 7993 D5
- 7994 E3
- F950 B4
- F951 B4
- F952 B8
- F953 C9
- F955 B8
- I951 B6
- I952 B6
- I953 B5
- I954 B5
- I955 C6
- I956 B8
- I957 C8
- I958 D4
- I959 D4

Mono Carrier: Rear I/O Cinch

A8 REAR I/O CINCH

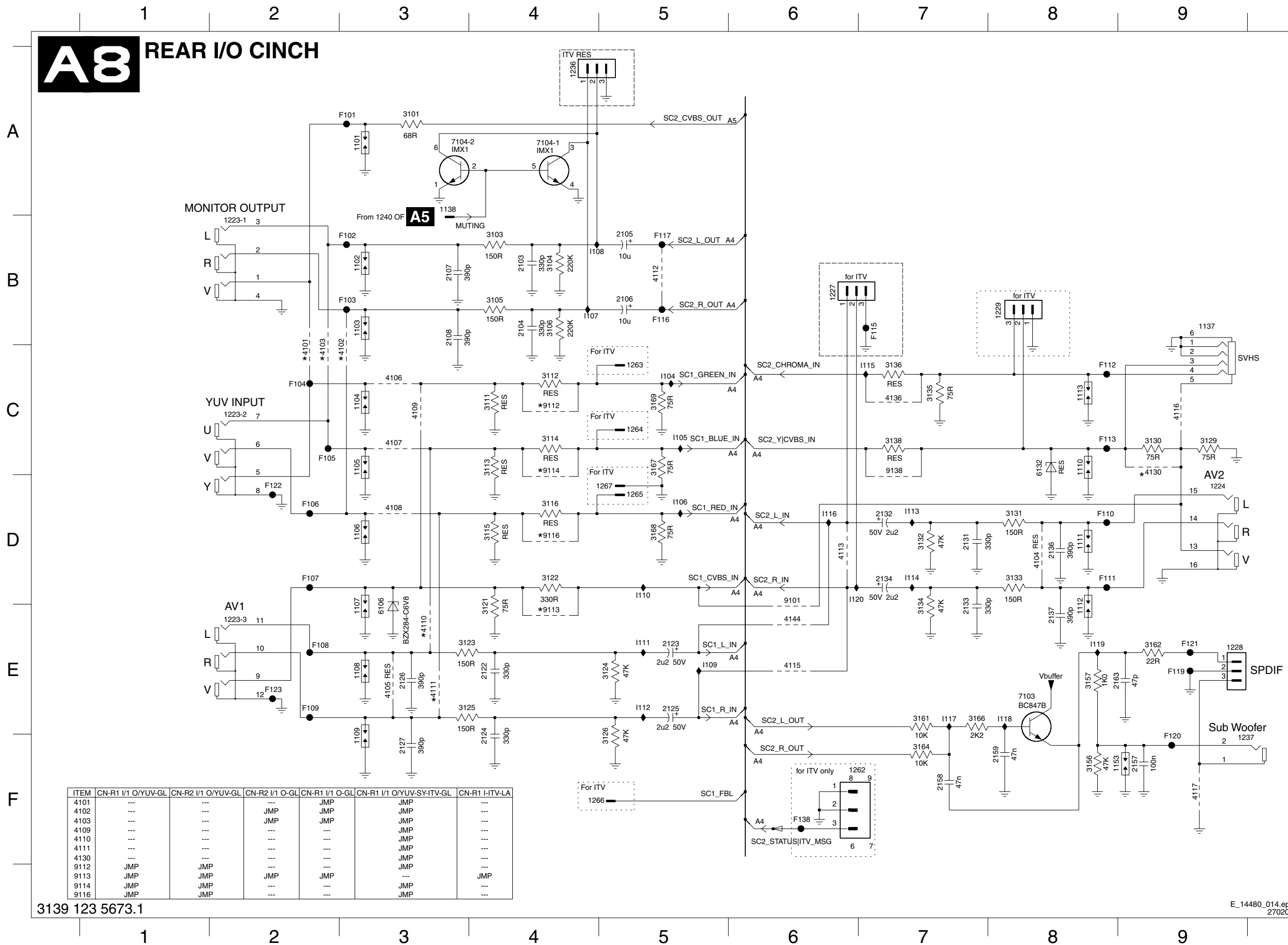

- 1101 A3
- 1102 B3
- 1103 B3
- 1104 C3
- 1105 C3
- 1106 D3
- 1107 E3
- 1108 E3
- 1109 F3
- 1110 C8
- 1111 D8
- 1112 E8
- 1113 C8
- 1137 B9
- 1138 A3
- 1153 F9
- 1223-1 B2
- 1223-2 C2
- 1223-3 E2
- 1227 B6
- 1228 E9
- 1229 B8
- 1236 A4
- 1237 F9
- 1262 F6
- 1263 C5
- 1264 C5
- 1265 D5
- 1266 F5
- 1267 D5
- 2103 B4
- 2104 B4
- 2105 B5
- 2106 B5
- 2107 B3
- 2108 B3
- 2122 E4
- 2123 E5
- 2124 F4
- 2125 E5
- 2126 E3
- 2127 F3
- 2131 D7
- 2132 D7
- 2133 E7
- 2134 D7
- 2136 D8
- 2137 E8
- 2157 F7
- 2158 F7
- 2159 F8
- 2163 E9
- 3101 A3
- 3103 B4
- 3104 B4
- 3105 B4
- 3106 B4
- 3111 C4
- 3112 C4
- 3113 C4
- 3114 C4
- 3115 C4
- 3116 C4
- 3121 C4
- 3122 C4
- 3123 C4
- 3124 C4
- 3125 C4
- 3126 C4
- 3127 C4
- 3128 C4
- 3129 C4
- 3130 C4
- 3131 C4
- 3132 C4
- 3133 C4
- 3134 C4
- 3135 C4
- 3136 C4
- 3137 C4
- 3138 C4
- 3139 C4
- 3140 C4
- 3141 C4
- 3142 C4
- 3143 C4
- 3144 C4
- 3145 C4
- 3146 C4
- 3147 C4
- 3148 C4
- 3149 C4
- 3150 C4
- 3151 C4
- 3152 C4
- 3153 C4
- 3154 C4
- 3155 C4
- 3156 C4
- 3157 C4
- 3161 E7
- 3162 E9
- 3164 F7
- 3166 E7
- 3167 C5
- 3168 D5
- 3169 C5
- 4101 C2
- 4102 C3
- 4103 C2
- 4104 D8
- 4105 E3
- 4106 C3
- 4107 C3
- 4108 D3
- 4109 C3
- 4110 E3
- 4111 E3
- 4112 B5
- 4113 D6
- 4115 E6
- 4116 C9
- 4117 F9
- 4130 C9
- 4136 C7
- 4144 E6
- 6106 E3
- 6132 C8
- 7103 E8
- 7104-1 A4
- 7104-2 A4
- 9101 D6
- 9112 C4
- 9113 E4
- 9114 C4
- 9116 D4
- 9138 C7
- F101 A3
- F102 B3
- F103 B3
- F104 A3
- F105 A3
- F106 A3
- F107 A3
- F108 A3
- F109 A3
- F109 E2
- F110 D8
- F111 D8
- F112 C8
- F113 C8
- F115 B7
- F116 B5
- F117 B5
- F119 E9
- F120 F9
- F121 E9
- F122 D2
- F123 E2
- F138 F6
- I104 C5
- I105 C5
- I106 D5
- I107 B4
- I108 B4
- I109 B4
- I110 B4
- I111 B4
- I112 B4
- I113 B4
- I114 B4
- I115 B4
- I116 B4
- I117 B4
- I118 B4
- I119 B4
- I120 B4
- I121 B4
- I122 B4
- I123 B4
- I124 B4
- I125 B4
- I126 B4
- I127 B4
- I128 B4
- I129 B4
- I130 B4
- I131 B4
- I132 B4
- I133 B4
- I134 B4
- I135 B4
- I136 B4
- I137 B4
- I138 B4
- I139 B4
- I140 B4
- I141 B4
- I142 B4
- I143 B4
- I144 B4
- I145 B4
- I146 B4
- I147 B4
- I148 B4
- I149 B4
- I150 B4
- I151 B4
- I152 B4
- I153 B4
- I154 B4
- I155 B4
- I156 B4
- I157 B4
- I158 B4
- I159 B4
- I160 B4
- I161 B4
- I162 B4
- I163 B4
- I164 B4
- I165 B4
- I166 B4
- I167 B4
- I168 B4
- I169 B4
- I170 B4
- I171 B4
- I172 B4
- I173 B4
- I174 B4
- I175 B4
- I176 B4
- I177 B4
- I178 B4
- I179 B4
- I180 B4
- I181 B4
- I182 B4
- I183 B4
- I184 B4
- I185 B4
- I186 B4
- I187 B4
- I188 B4
- I189 B4
- I190 B4
- I191 B4
- I192 B4
- I193 B4
- I194 B4
- I195 B4
- I196 B4
- I197 B4
- I198 B4
- I199 B4
- I200 B4

3139 123 5673.1

E_14480_014.eps
270204

Mono Carrier: Front Control

A9 FRONT CONTROL

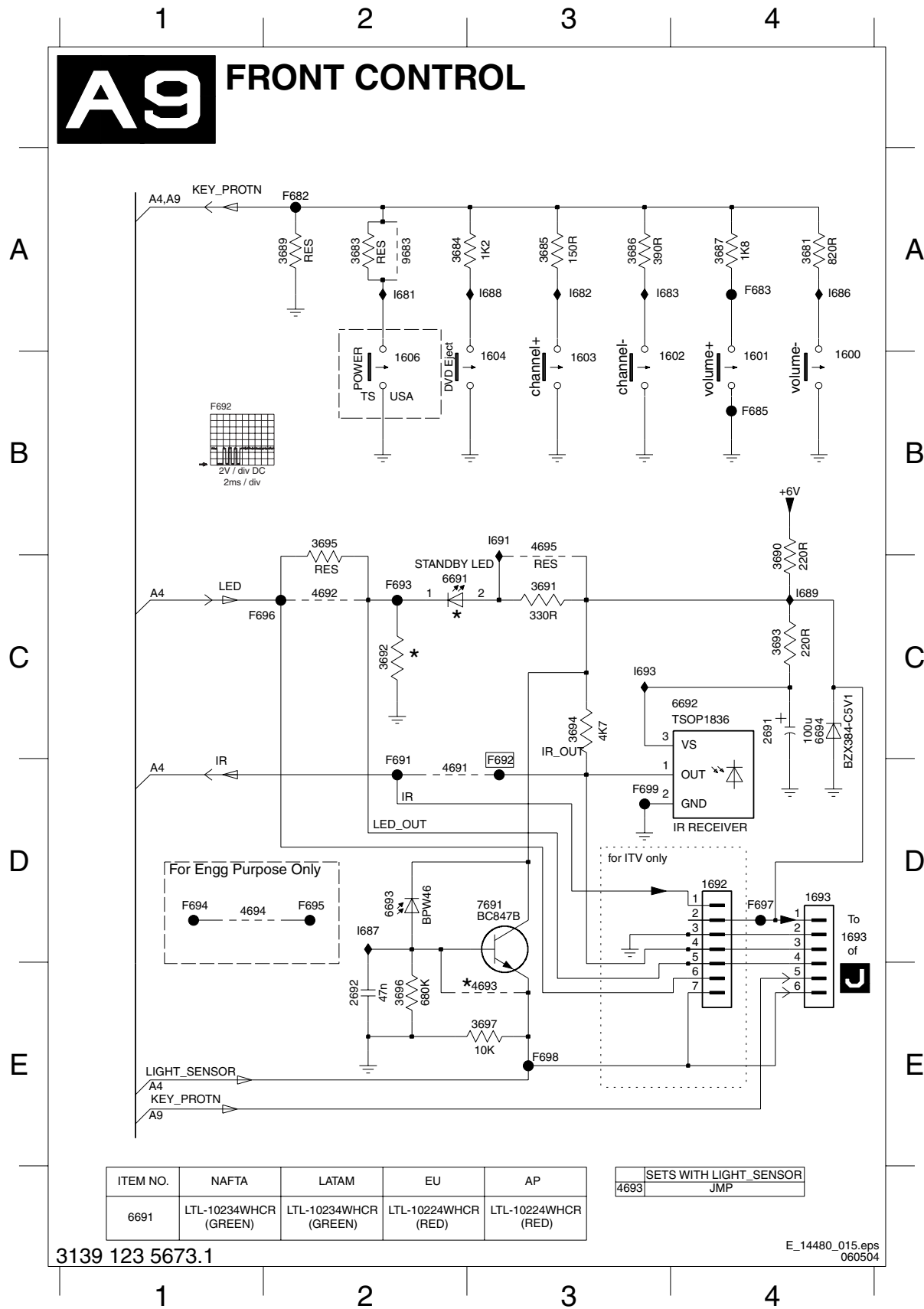

- 1600 A4
- 1601 A4
- 1602 A4
- 1603 B3
- 1604 B3
- 1606 B2
- 1692 D4
- 1693 D4
- 2691 C4
- 2692 E2
- 3681 A4
- 3683 A2
- 3684 A2
- 3685 A3
- 3686 A3
- 3687 A4
- 3689 A2
- 3690 C4
- 3691 C3
- 3692 C2
- 3693 C4
- 3694 C3
- 3695 B2
- 3696 E2
- 3697 E3
- 4691 D2
- 4692 C2
- 4693 E3
- 4694 D1
- 4695 B3
- 6691 C3
- 6692 C4
- 6693 D2
- 6694 C4
- 7691 D3
- 9683 A2
- F682 A2
- F683 A4
- F685 B4
- F691 D2
- F692 D3
- F693 C2
- F694 D1
- F695 D2
- F696 C1
- F697 D4
- F698 E3
- F699 D3
- I681 A2
- I682 A3
- I683 A3
- I684 A4
- I686 A4
- I687 D2
- I688 A3
- I689 C4
- I691 B3
- I693 C3

CRT Panel

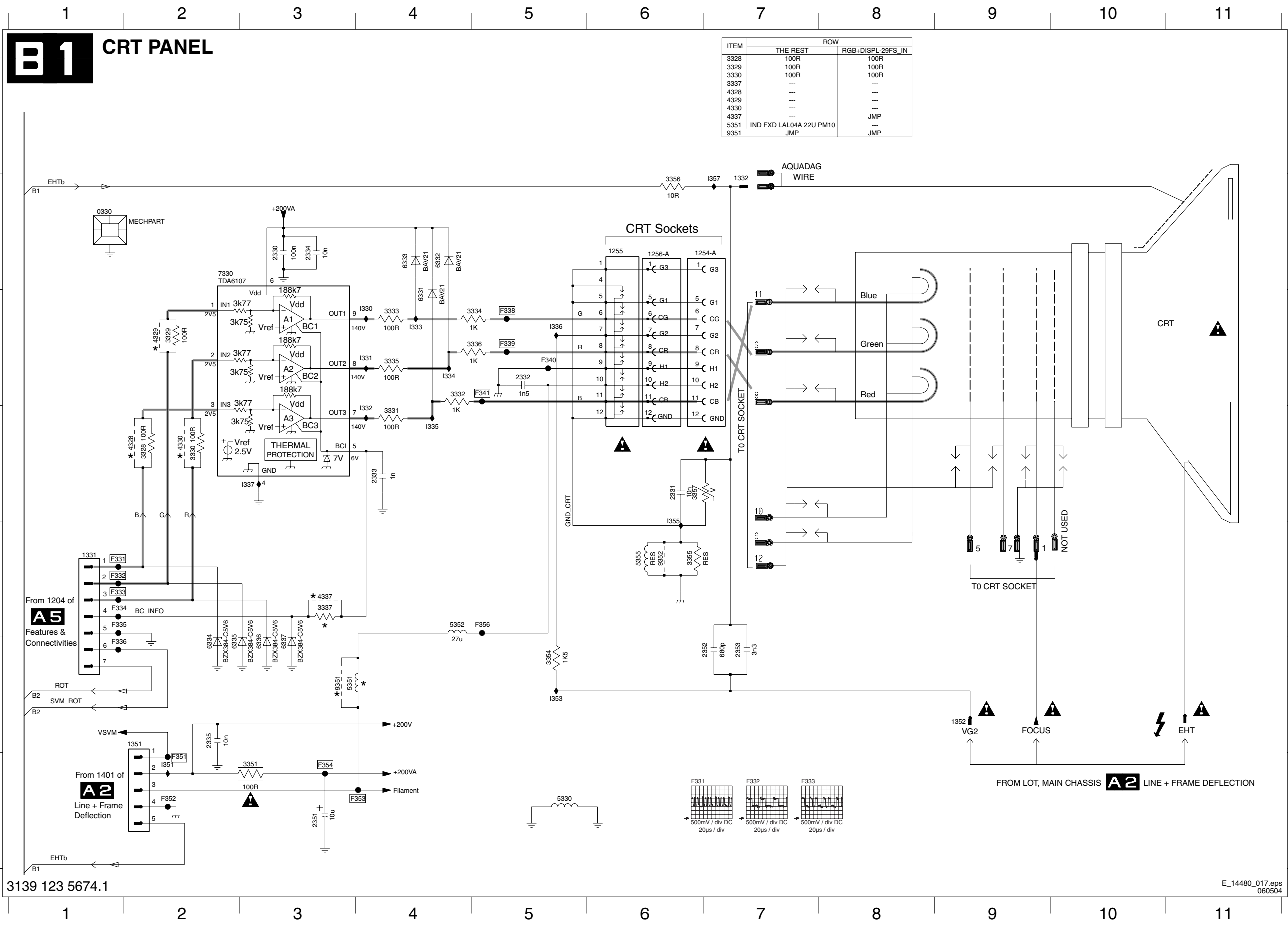

- 0330 B1
- 1254-A B7
- 1255 B6
- 1256-A B6
- 1331 E1
- 1332 B7
- 1351 F2
- 1352 F9
- 2330 B3
- 2331 D6
- 2332 C5
- 2333 D4
- 2334 B3
- 2335 F2
- 2351 G3
- 2352 F6
- 2353 F7
- 3328 D2
- 3329 C2
- 3330 D2
- 3331 D4
- 3332 C4
- 3333 C4
- 3334 C5
- 3335 C4
- 3336 C5
- 3337 E3
- 3351 G3
- 3354 F5
- 3355 E6
- 3356 B6
- 3357 D6
- 4328 D2
- 4329 C2
- 4330 D2
- 4337 E3
- 5330 G5
- 5351 F3
- 5352 E4
- 5355 E6
- 6331 C4
- 6332 B4
- 6333 B4
- 6334 F2
- 6335 F2
- 6336 F3
- 6337 F3
- 7330 B2
- 9351 F3
- 9352 E6
- F331 E1
- F332 E1
- F333 E1
- F334 E1
- F335 E1
- F336 F1
- F338 C5
- F339 C5
- F340 C5
- F341 C5
- F351 G2
- F352 G2
- F353 G4
- F354 G3
- F356 E5
- I330 C4
- I331 C4
- I333 C4
- I334 C4
- I335 D4
- I336 D4
- I337 D3
- I351 G2
- I353 F5
- I355 D6
- I357 B7

3139 123 5674.1

E_14480_017.eps 060504

CRT Panel: Eco Scavem

B2 ECO SCAVEM

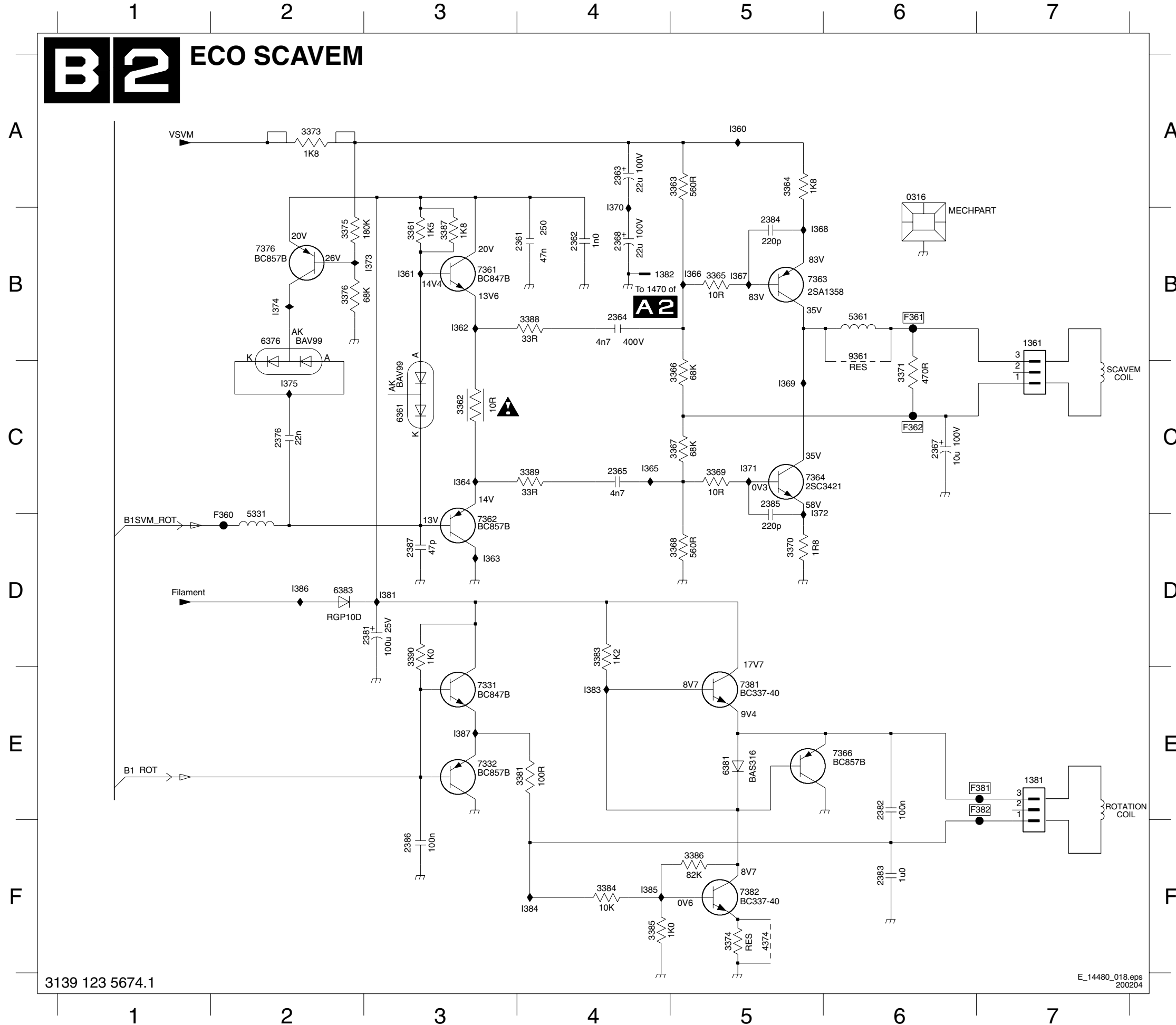

- 0316 A6
- 1361 B7
- 1381 E7
- 1382 B4
- 2361 B4
- 2362 B4
- 2363 A4
- 2364 B4
- 2365 C4
- 2367 C6
- 2368 B4
- 2376 C2
- 2381 D3
- 2382 E6
- 2383 F6
- 2384 B5
- 2385 C5
- 2386 F3
- 2387 D3
- 3361 B3
- 3362 C3
- 3363 A5
- 3364 A5
- 3365 B5
- 3366 C5
- 3367 C5
- 3368 D5
- 3369 C5
- 3370 D5
- 3371 C6
- 3373 A2
- 3374 F5
- 3375 B2
- 3376 B2
- 3381 E4
- 3383 D4
- 3384 F4
- 3385 F4
- 3386 F5
- 3387 B3
- 3388 B4
- 3389 C4
- 3390 D3
- 4374 F5
- 5331 D2
- 5361 B6
- 6361 C3
- 6376 B2
- 6381 E5
- 6383 D2
- 7331 E3
- 7332 E3
- 7361 B3
- 7362 D3
- 7363 B5
- 7364 C5
- 7366 E6
- 7376 B2
- 7381 E5
- 7382 F5
- 9361 B6
- F360 D2
- F361 B6
- F362 C6
- F381 E7
- F382 E7
- I360 A5
- I361 B3
- I362 B3
- I363 D3
- I364 C3
- I365 C4
- I366 B5
- I367 B5
- I368 B5
- I369 C5
- I370 A4
- I371 C5
- I372 C5
- I373 B3
- I374 B2
- I375 C2
- I381 D3
- I383 E4
- I384 F4
- I385 F4
- I386 D2
- I387 E3

Side AV + Headphone Panel (PV-2)

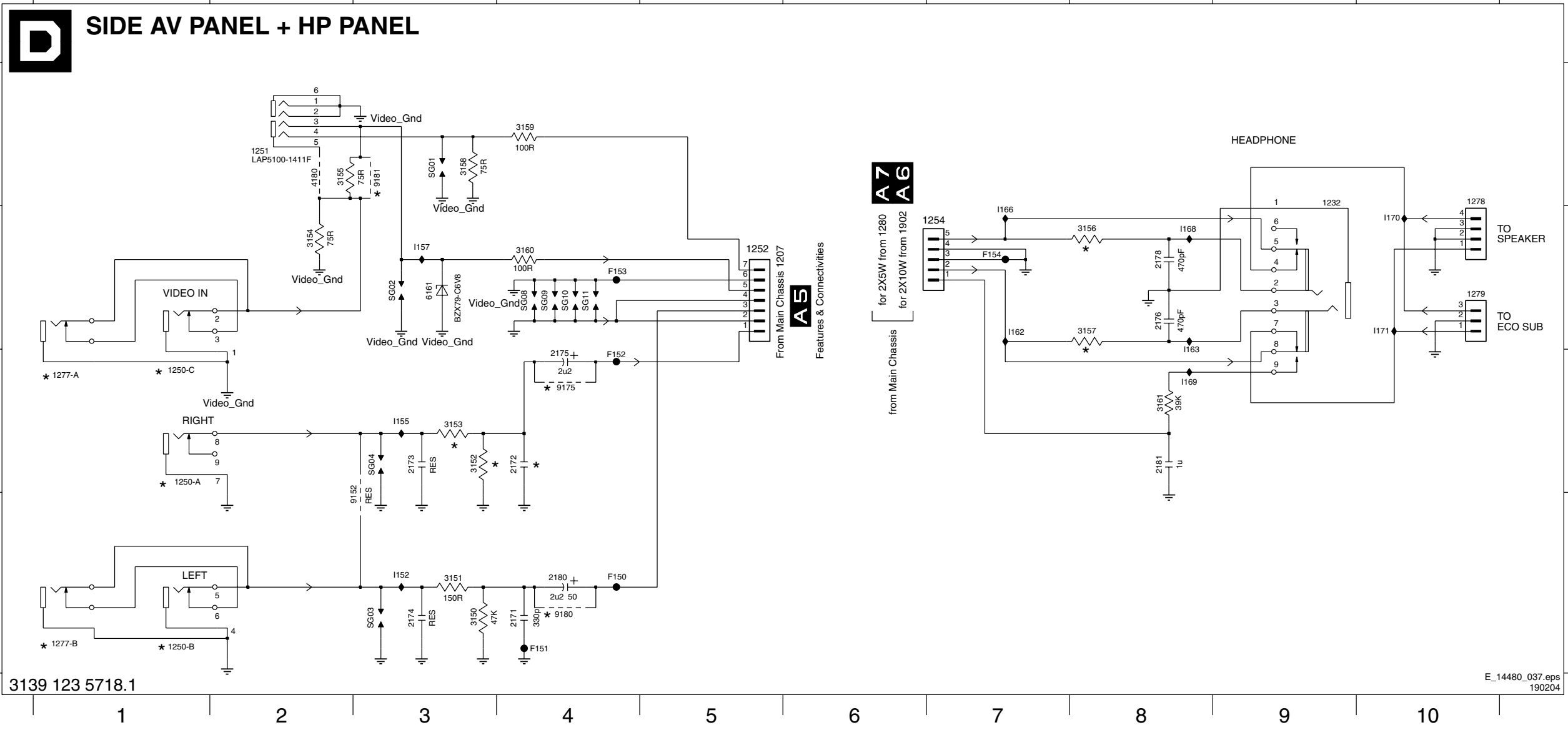

3139 123 5718.1

E_14480_037.eps
190204

- 1232 A9
- 1250-A C1
- 1250-B D1
- 1250-C C1
- 1251 A2
- 1252 B5
- 1254 B6
- 1277-A C1
- 1277-B D1
- 1278 A10
- 1279 B10
- 2171 D4
- 2172 C4
- 2173 C3
- 2174 D3
- 2175 C4
- 2176 B8
- 2178 B8
- 2180 D4
- 2181 C8
- 3150 D3
- 3151 D3
- 3152 C3
- 3153 C3
- 3154 B2
- 3155 A2
- 3156 B8
- 3157 B8
- 3158 A3
- 3159 A4
- 3160 B4
- 3161 C8
- 4180 A2
- 6161 B3
- 9152 D3
- 9175 C4
- 9180 D4
- 9181 A3
- F150 D4
- F151 D4
- F152 C4
- F153 B4
- F154 B7
- I152 D3
- I155 C3
- I157 B3
- I162 B7
- I163 C8
- I166 B7
- I168 B8
- I169 C8
- I170 B10
- I171 B10
- SG01 A3
- SG02 B3
- SG03 D3
- SG04 C3
- SG08 B4
- SG09 B4
- SG10 B4
- SG11 B4

Side AV + Headphone Panel (FL-9)

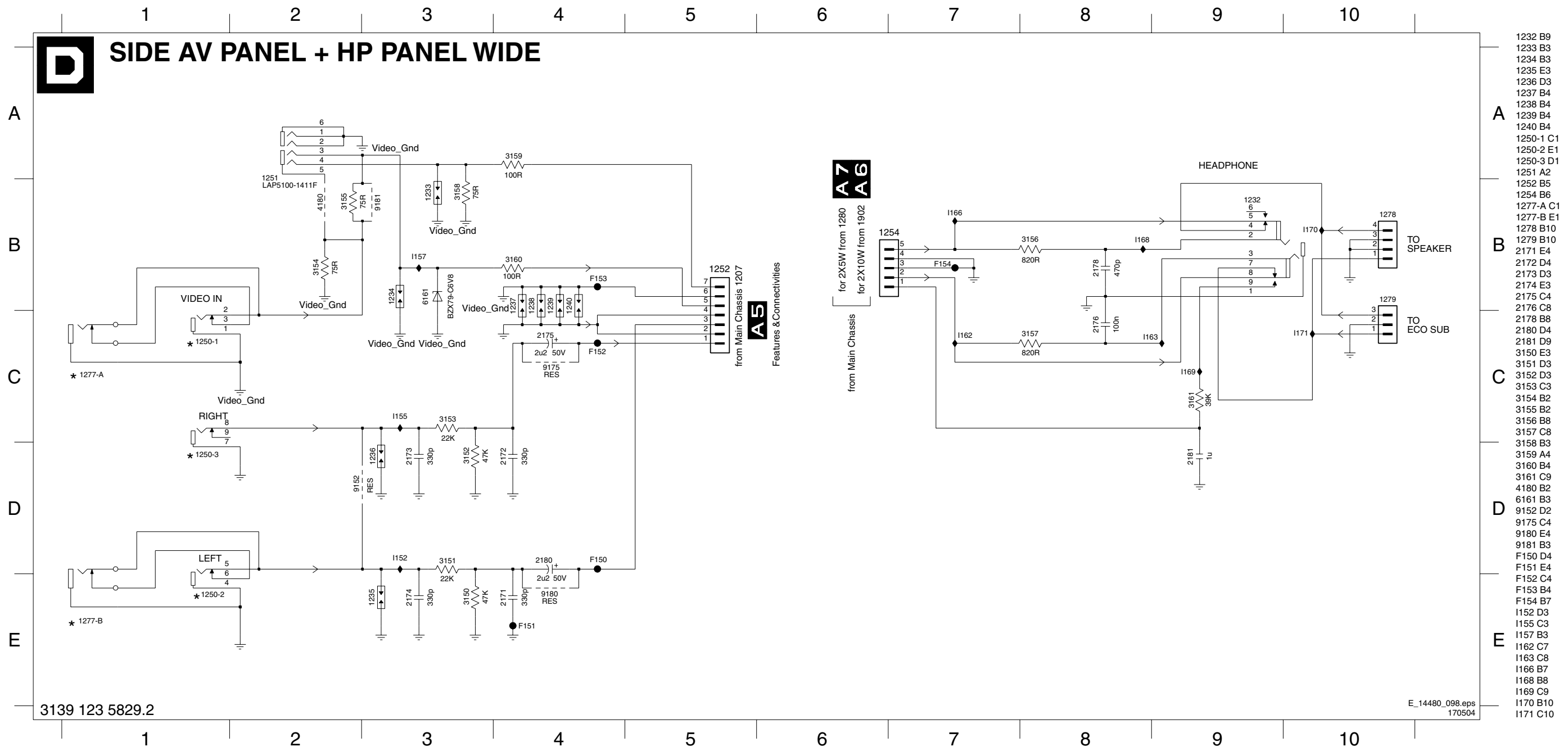

Power Supply PIP Panel

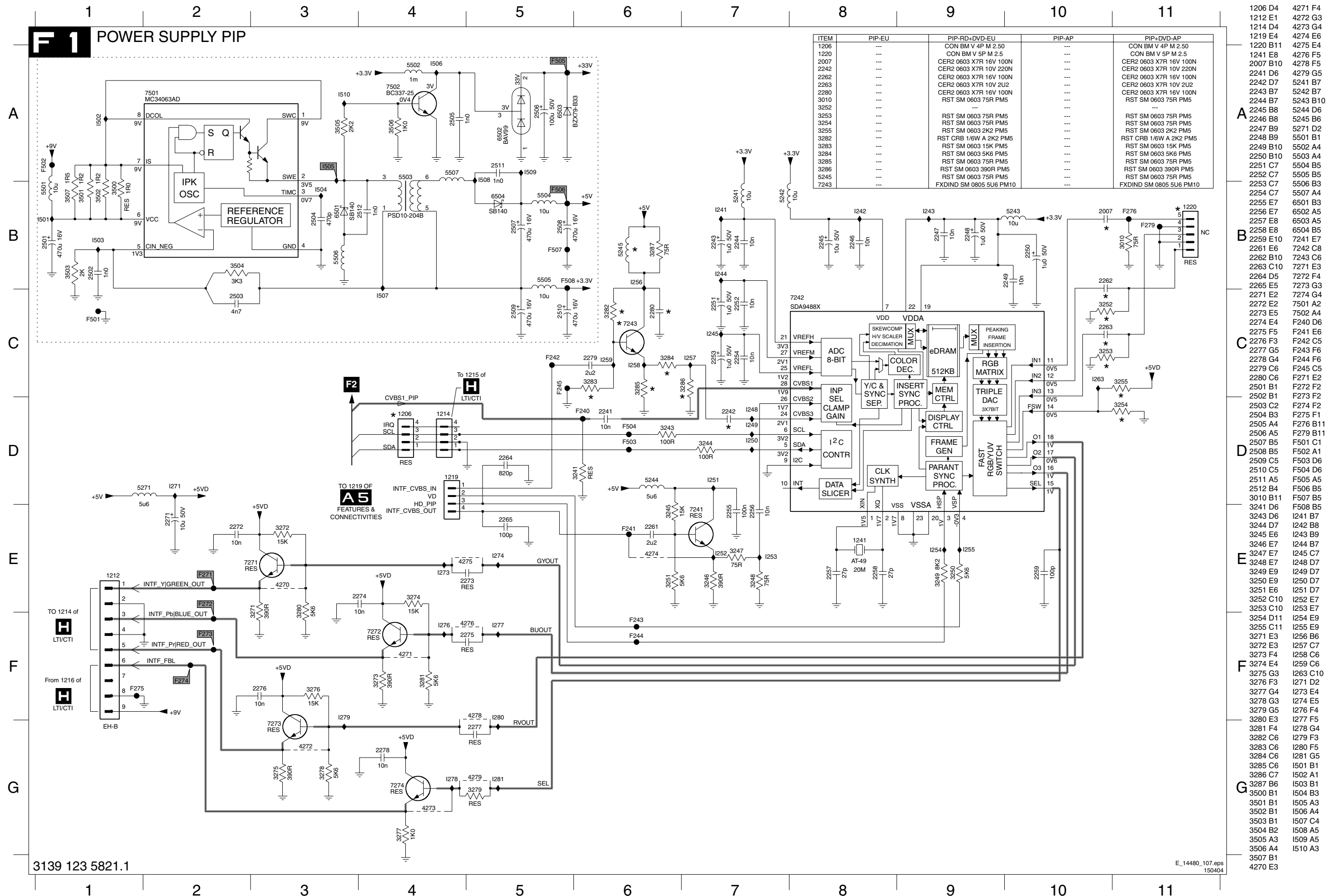

Tuner IF and Demodulator PIP Panel

F2 TUNER IF & DEMODULATOR PIP

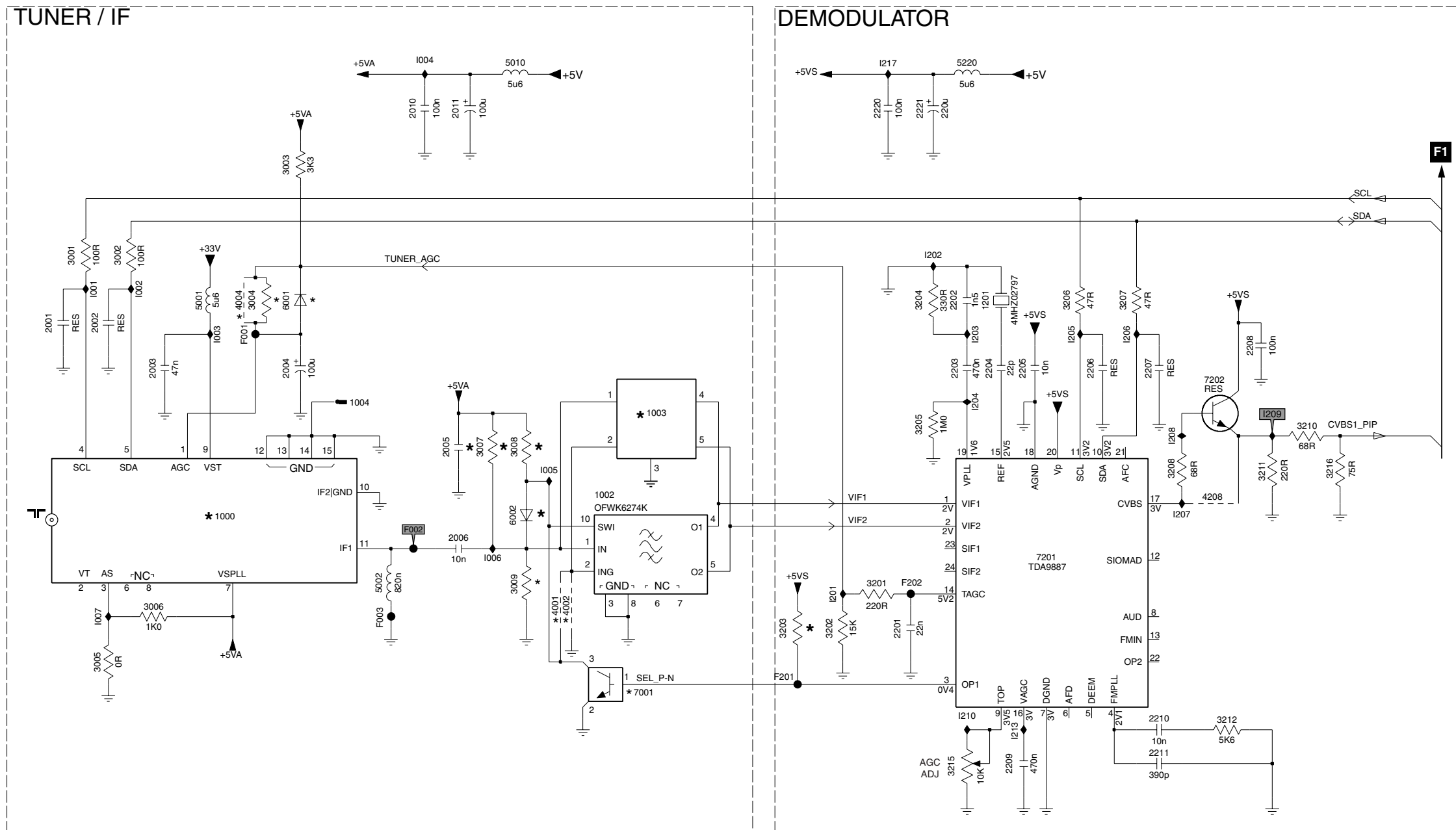

ITEM	PIP-EU	PIP-RD+DVD-EU	PIP-AP	PIP+DVD-AP
1000	TUNER UV1316E/A I-4	TUNER UV1316T/A I X-3	TUNER UV1316T/A I-4	TUNER UV1316T/A I-4
1003	FIL SAW 38MHZ9 OFWK3953	FIL SAW 38MHZ9 OFWK3953	FIL SAW 38MHZ9 OFWK7257	FIL SAW 38MHZ9 OFWK7257
2005	CER2 0603 X7R 50V 10N	CER2 0603 X7R 50V 10N
3004	RST SM 0603 10K PM5	RST SM 0603 10K PM5
3007	RST SM 0603 6K8 PM5	RST SM 0603 6K8 PM5
3008	RST SM 0603 2K2 PM5	RST SM 0603 2K2 PM5
3009	RST SM 0603 2K2 PM5	RST SM 0603 2K2 PM5
3203	RST CRB 1/6W A 4K7 PM5	RST CRB 1/6W A 4K7 PM5
4001	RST SM 0603 JUMP 0R05	RST SM 0603 JUMP 0R05
4002	RST SM 0603 JUMP 0R05	RST SM 0603 JUMP 0R05
4004	RST SM 0603 JUMP 0R05	RST SM 0603 JUMP 0R05
6001	DIO SIG SM 1SS356 (RH)	DIO SIG SM 1SS356 (RH)
6002	DIO SIG SM 1SS356 (RH)	DIO SIG SM 1SS356 (RH)
7001	TRA SIG SM PDTTC124ET (C)	TRA SIG SM PDTTC124ET (C)

- 1000 D3
- 1002 D5
- 1003 D5
- 1004 D3
- 1201 C7
- 2001 C1
- 2002 C2
- 2003 C2
- 2004 C3
- 2005 D4
- 2006 D4
- 2010 B4
- 2011 B4
- 2201 E7
- 2202 C7
- 2203 C7
- 2204 C7
- 2205 C8
- 2206 C8
- 2207 C8
- 2208 C9
- 2209 F7
- 2210 F8
- 2211 F8
- 2220 B7
- 2221 B7
- 3001 C2
- 3002 C2
- 3003 B3
- 3004 C3
- 3005 E2
- 3006 E2
- 3007 D4
- 3008 D4
- 3009 E4
- 3201 E7
- 3202 E6
- 3203 E6
- 3204 C7
- 3205 D7
- 3206 C8
- 3207 C8
- 3208 D9
- 3210 D9
- 3211 D9
- 3212 F9
- 3215 F7
- 3216 D10
- 4001 E5
- 4002 E5
- 4004 C3
- 4208 D9
- 5001 C2
- 5002 E3
- 5010 A4
- 5220 A7
- 6001 C3
- 6002 D4
- 7001 E5
- 7201 E8
- 7202 C9
- F001 C3
- F002 D4
- F003 E4
- F201 E6
- F202 E7
- I001 C2
- I002 C2
- I003 C2
- I004 A4
- I005 D5
- I006 E4
- I007 E2
- I201 E6
- I202 C7
- I203 C7
- I204 D7
- I205 C8
- I206 C8
- I207 D9
- I208 D8
- I209 D9
- I210 F7
- I213 F7
- I217 A7

Linearity & Panorama Panel

Layout Linearity & Panorama Panel (Top Side)

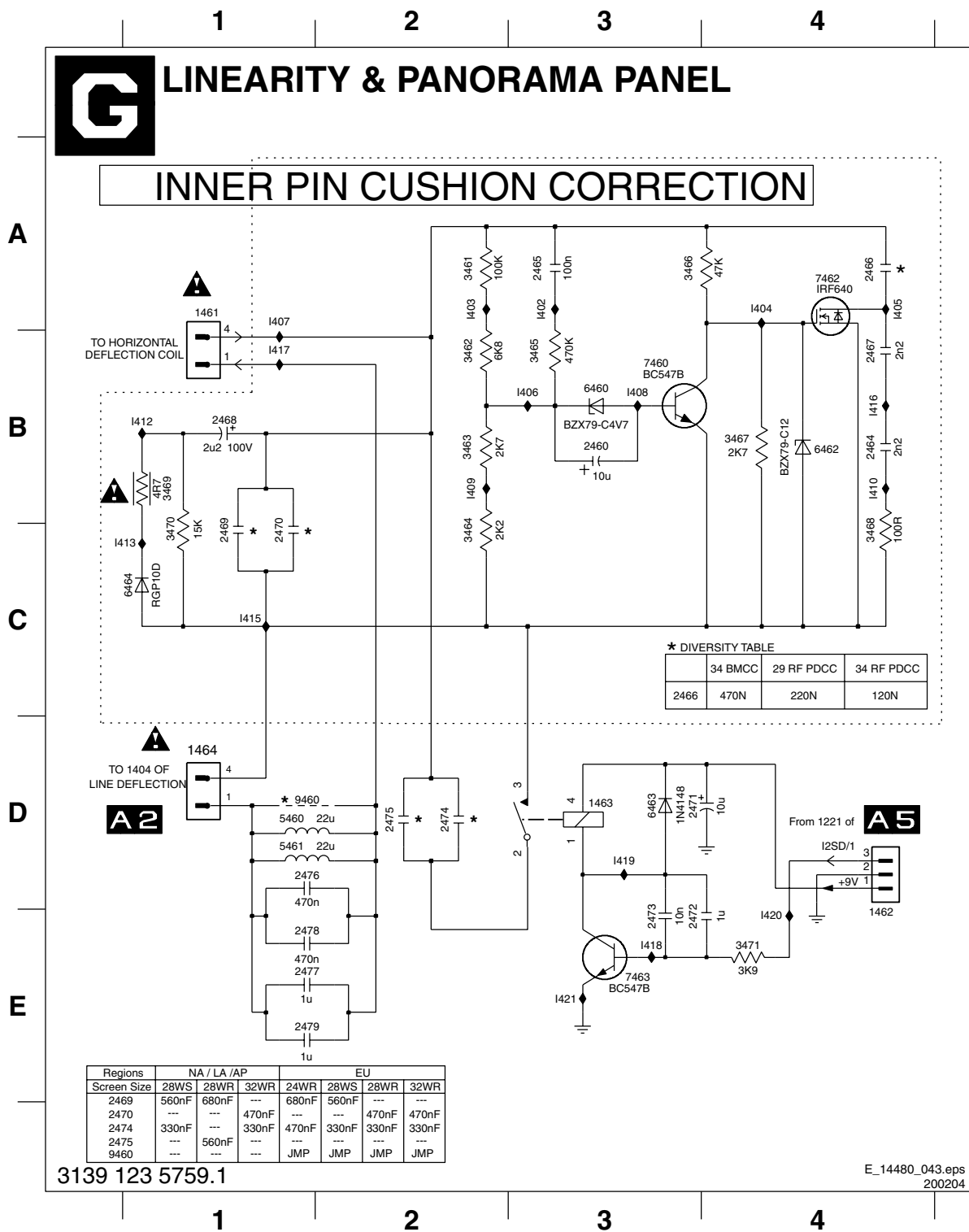

- 1461 A1
- 1462 D4
- 1463 D3
- 1464 D1
- 2460 B3
- 2464 B4
- 2465 A3
- 2466 A4
- 2467 B4
- 2468 B1
- 2469 C1
- 2470 C1
- 2471 D3
- 2472 E3
- 2473 E3
- 2474 D2
- 2475 D2
- 2476 D1
- 2477 E1
- 2478 E1
- 2479 E1
- 3461 A2
- 3462 B2
- 3463 B2
- 3464 C2
- 3465 B3
- 3466 A3
- 3467 B4
- 3468 C4
- 3469 B1
- 3470 C1
- 3471 E4
- 5460 D1
- 5461 D1
- 6460 B3
- 6462 B4
- 6463 D3
- 6464 C1
- 7460 B3
- 7462 A4
- 7463 E3
- 9460 D1
- I402 A3
- I403 A2
- I404 A4
- I405 A4
- I406 B3
- I407 A1
- I408 B3
- I409 B2
- I410 B4
- I412 B1
- I413 C1
- I415 C1
- I416 B4
- I417 B1
- I418 E3
- I419 D3
- I420 E4
- I421 E3

- 1461 B2
- 1462 D2
- 1463 D3
- 1464 C2
- 2460 A1
- 2464 B2
- 2465 B1
- 2466 B2
- 2467 A2
- 2468 C2
- 2469 B2
- 2470 B1
- 2471 D2
- 2472 D2
- 2473 D2
- 2474 D2
- 2475 C2
- 2476 C2
- 2477 C2
- 2478 C2
- 3461 B2
- 3462 B1
- 3463 B1
- 3464 B1
- 3465 B1
- 3466 B2
- 3467 A2
- 3468 A2
- 3469 C2
- 3470 C1
- 3471 C2
- 5460 B2
- 5461 C2
- 6460 A1
- 6461 A2
- 6462 D2
- 6463 C1
- 7460 A1
- 7461 A2
- 7462 D2
- 9460 B2

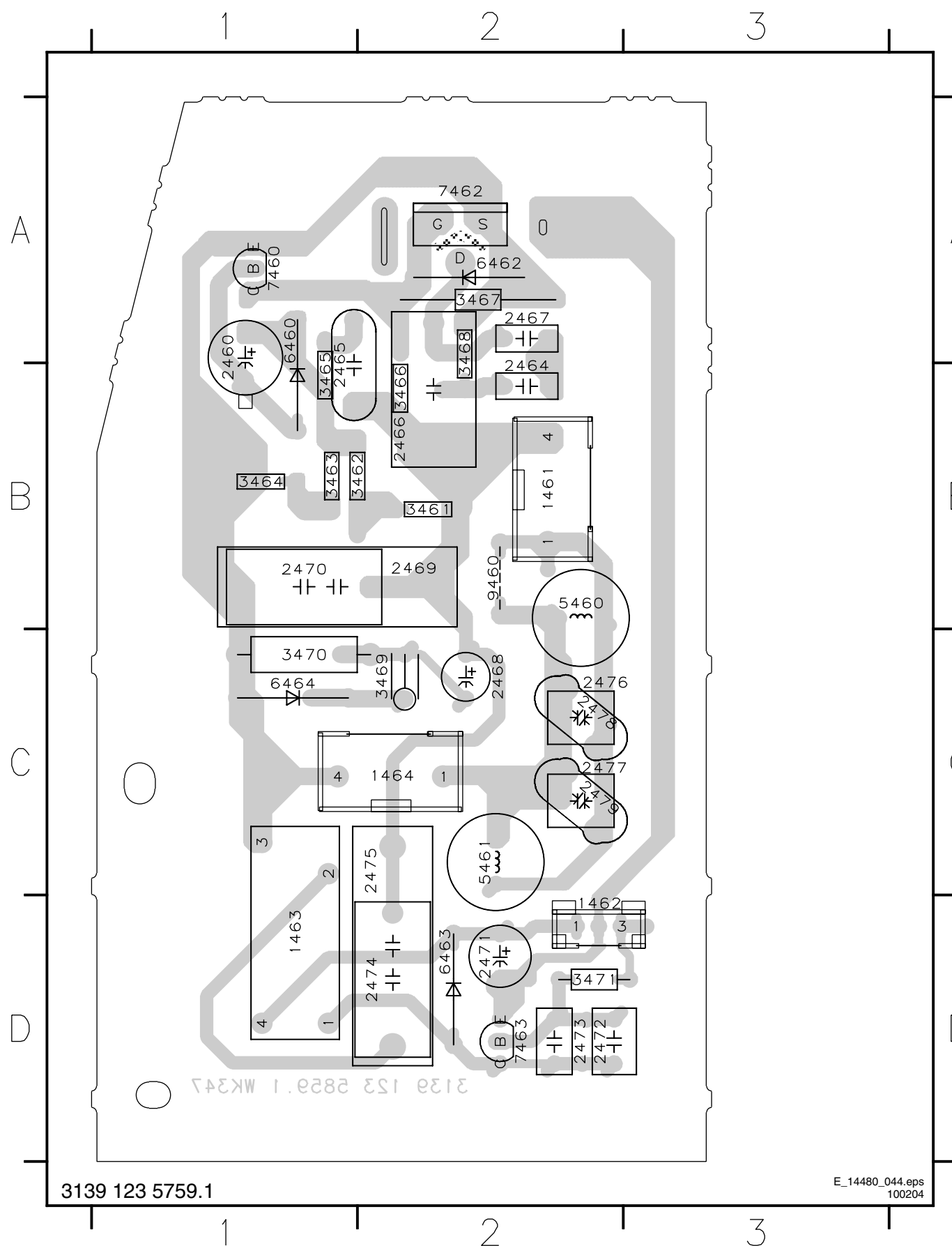

LTI/CTI Interface Panel

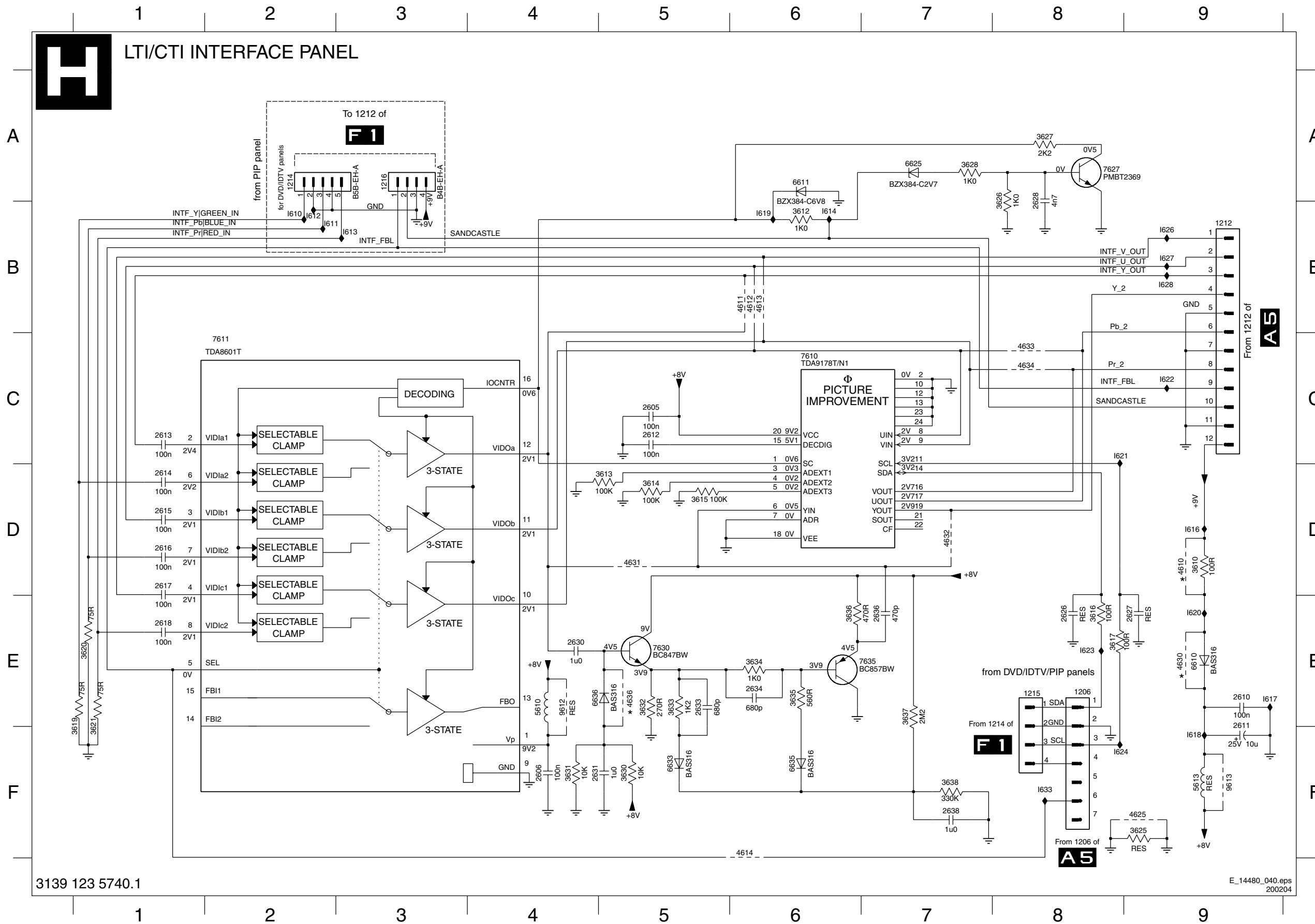

3139 123 5740.1

E_14480_040.eps
200204

- 1206 E8
- 1212 B9
- 1214 A2
- 1215 E8
- 1216 A3
- 2605 C5
- 2606 F4
- 2610 E9
- 2611 E9
- 2612 C5
- 2613 C1
- 2614 D1
- 2615 D1
- 2616 D1
- 2617 D1
- 2618 E1
- 2626 E8
- 2627 E9
- 2628 A8
- 2630 E4
- 2631 F4
- 2633 E5
- 2634 E6
- 2636 E7
- 2638 F7
- 3610 D9
- 3612 B6
- 3613 D5
- 3614 D5
- 3615 D5
- 3616 E8
- 3617 E8
- 3619 E1
- 3620 E1
- 3621 E1
- 3625 F9
- 3626 A8
- 3627 A8
- 3628 A7
- 3630 F5
- 3631 F4
- 3632 E5
- 3633 E5
- 3634 E6
- 3635 E6
- 3636 E6
- 3637 E7
- 3638 F7
- 4610 D9
- 4611 B6
- 4612 B6
- 4613 B6
- 4614 F6
- 4625 F9
- 4630 E9
- 4631 D5
- 4632 D7
- 4633 C8
- 4634 C8
- 4636 E5
- 5610 E4
- 5613 F9
- 6610 E9
- 6611 A6
- 6625 A7
- 6633 F5
- 6635 F6
- 6636 E4
- 7610 C6
- 7611 C2
- 7627 A8
- 7630 E5
- 7635 E6
- 9612 E4
- 9613 F9
- 1610 B2
- 1611 B2
- 1612 E2
- 1613 B3
- 1614 B6
- 1616 D9
- 1617 E9
- 1618 F9
- 1619 B6
- 1620 E9
- 1621 C8
- 1622 C9
- 1623 E8
- 1624 F8
- 1626 B9
- 1627 B9
- 1628 B9
- 1633 F8

Front Interface Panel (PV-2)

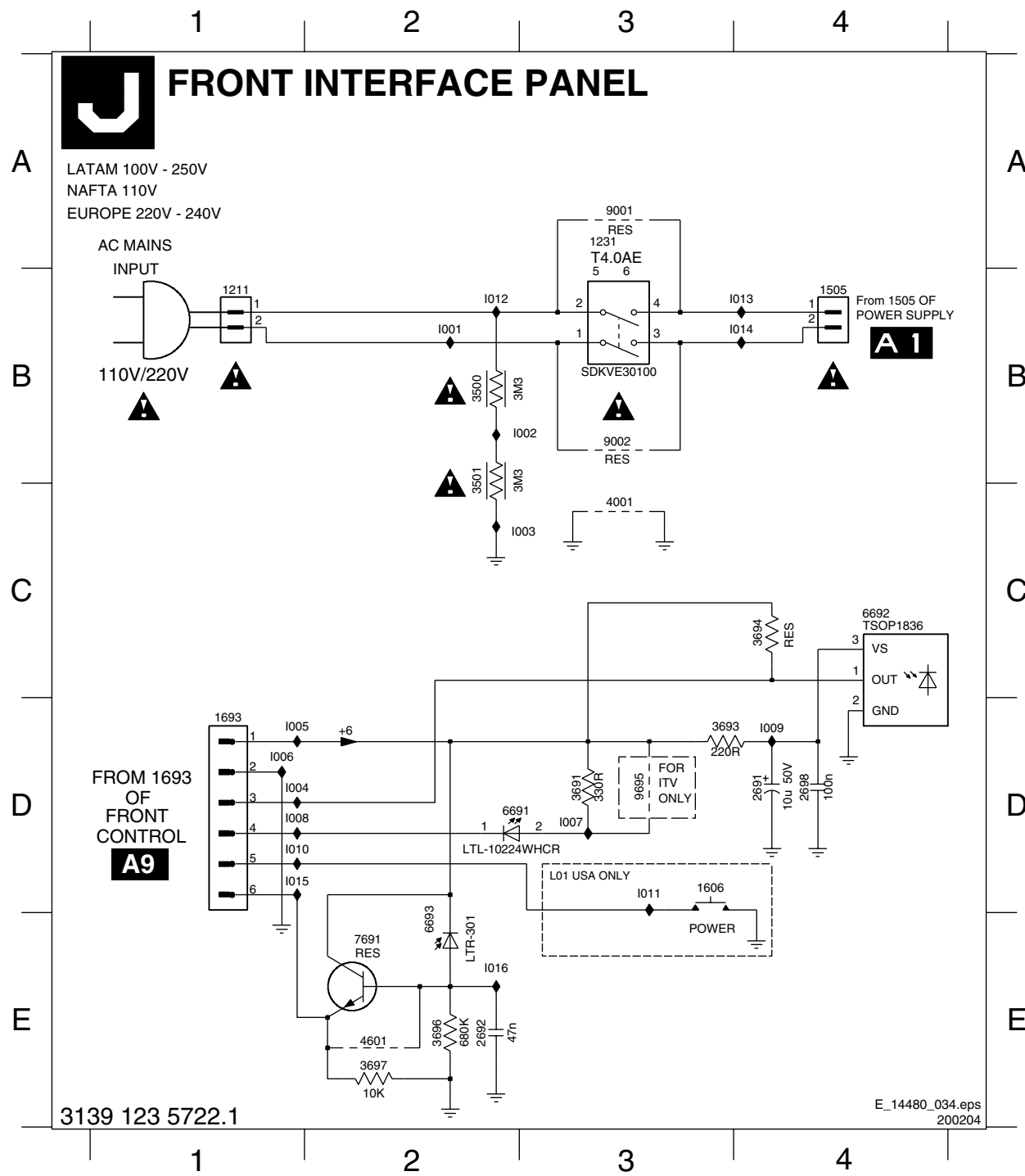

- 1211 B1
- 1231 A3
- 1505 B4
- 1606 D3
- 1693 D1
- 2691 D4
- 2692 E2
- 2698 D4
- 3500 B2
- 3501 B2
- 3691 D3
- 3693 D3
- 3694 C4
- 3696 E2
- 3697 E2
- 4001 C3
- 4601 E2
- 6691 D3
- 6692 C4
- 6693 E2
- 7691 E2
- 9001 A3
- 9002 B3
- 9695 D3
- 1001 B2
- 1002 B3
- 1003 C3
- 1004 D1
- 1005 D1
- 1006 D1
- 1007 D3
- 1008 D1
- 1009 D4
- 1010 D1
- 1011 D3
- 1012 B2
- 1013 B4
- 1014 B4
- 1015 D1
- 1016 E2

Layout Front Interface Panel (PV-2) (Top Side)

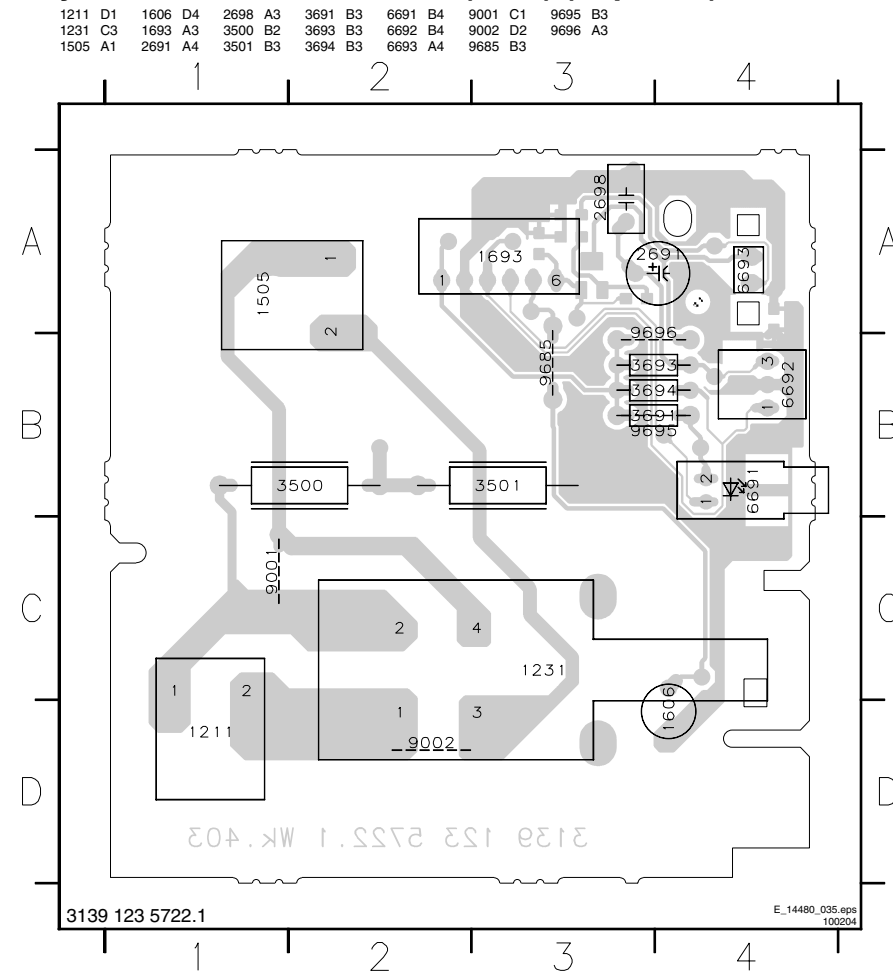

Layout Front Interface Panel (PV-2) (Bottom Side)

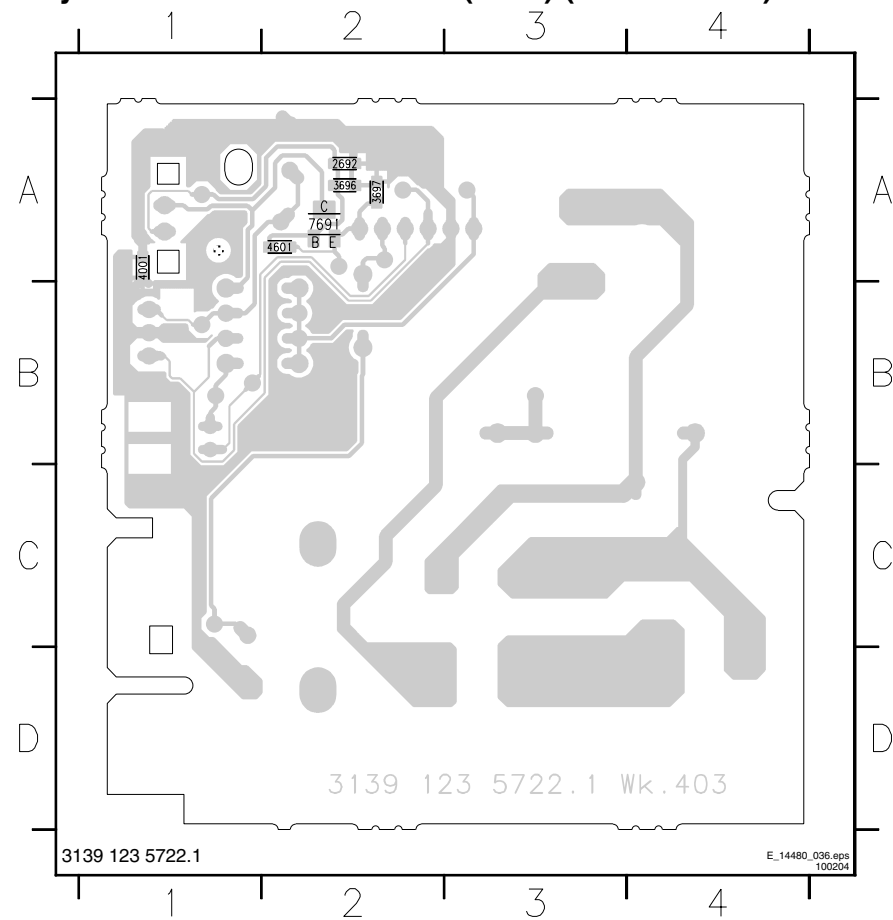

Front Interface Panel (FL-9)

Layout Front Interface Panel (FL-9) (Top Side)

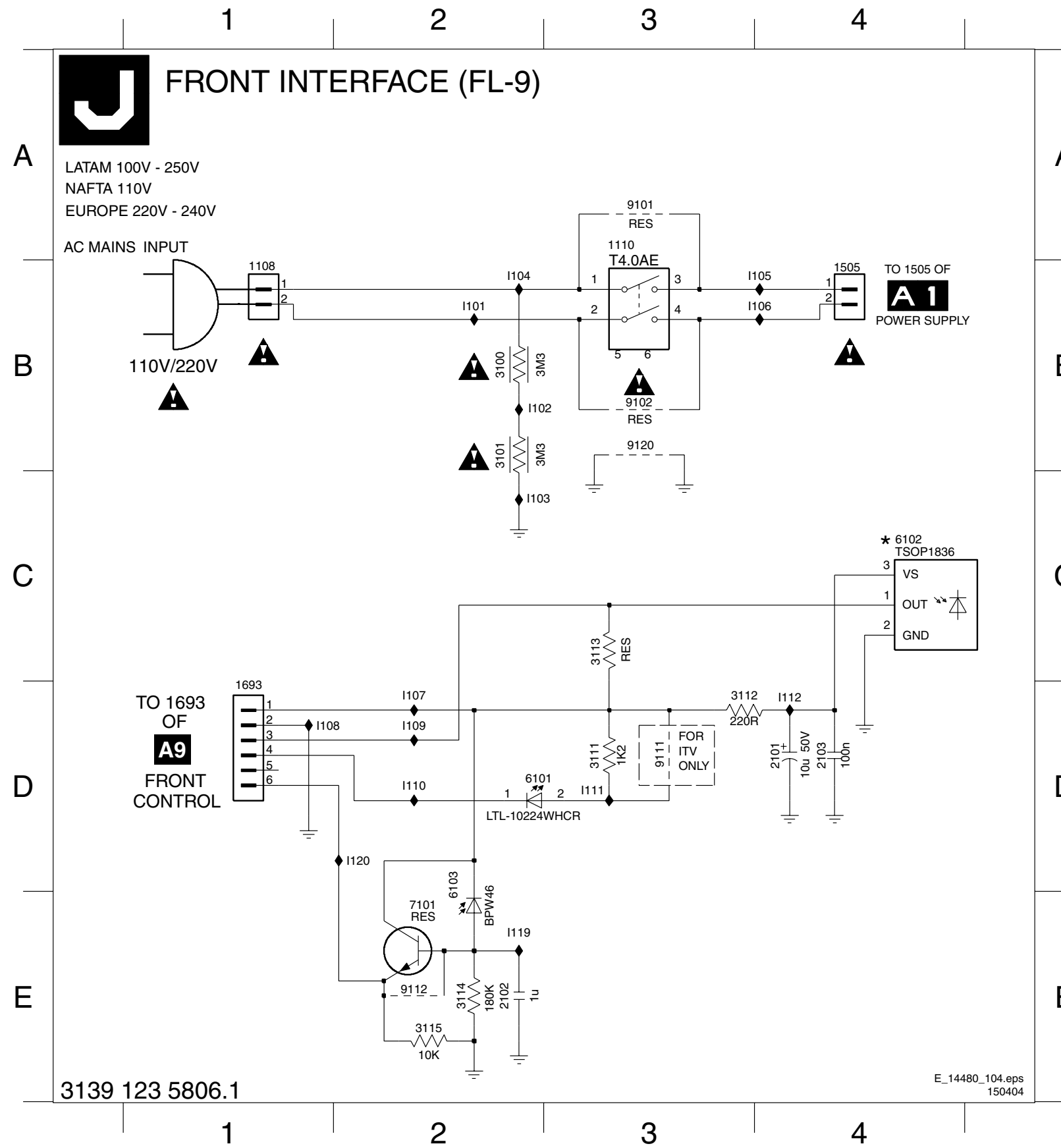

- 1108 B1
- 1110 A3
- 1505 B4
- 1693 D1
- 2101 D4
- 2102 E2
- 2103 D4
- 3100 B2
- 3101 B2
- 3111 D3
- 3112 D3
- 3113 C3
- 3114 E2
- 3115 E2
- 6101 D3
- 6102 C4
- 6103 E2
- 7101 E2
- 9101 A3
- 9102 B3
- 9111 D3
- 9112 E2
- 9120 B3
- I101 B2
- I102 B2
- I103 C2
- I104 B2
- I105 B4
- I106 B4
- I107 D2
- I108 D1
- I109 D2
- I110 D2
- I111 D3
- I112 D4
- I119 E2
- I120 D2

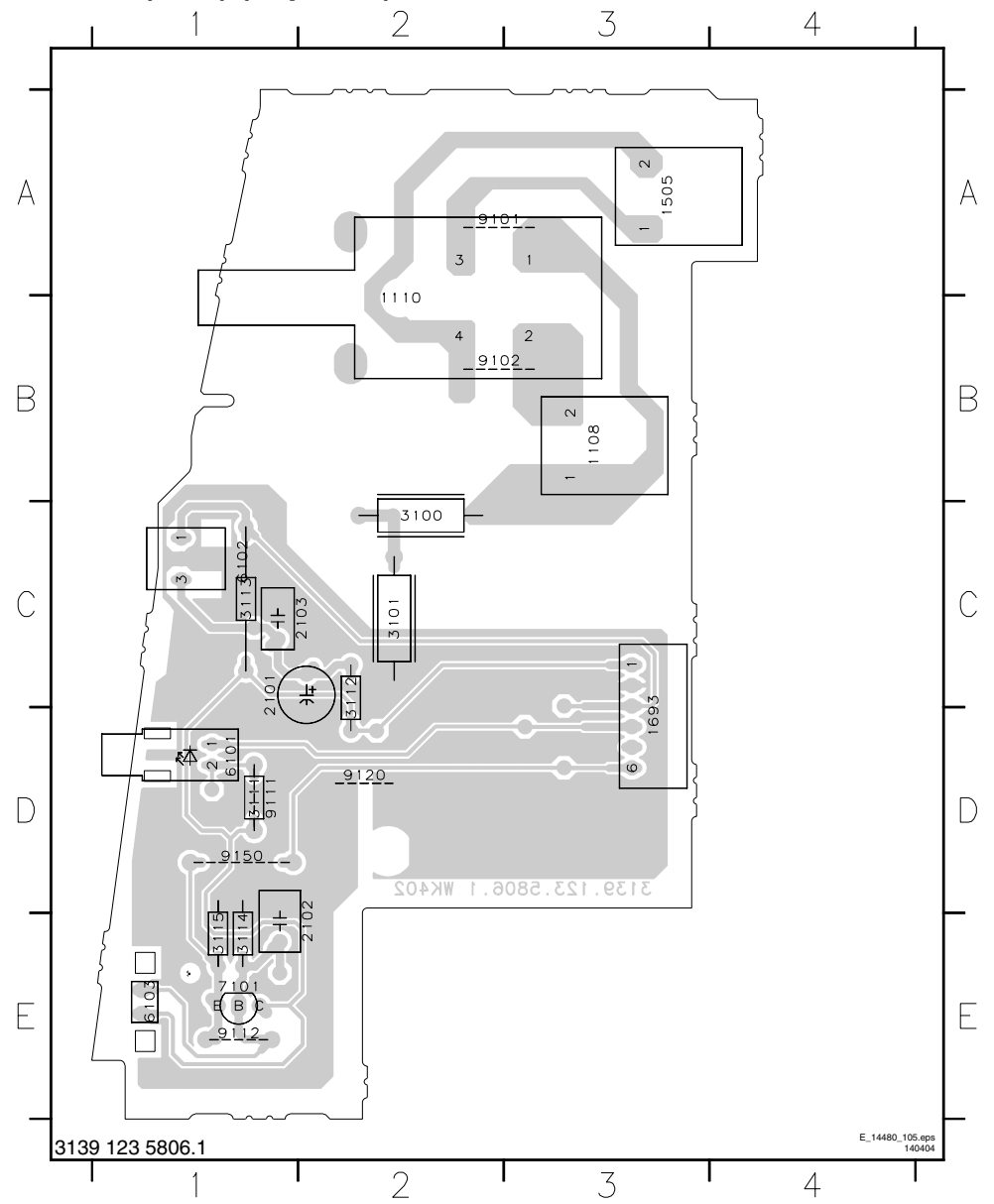

3139 123 5806.1

E_14480_104.eps
150404

3139 123 5806.1

E_14480_105.eps
140404

www.s-manuals.com