

# 3.2 OVERALL CONNECTION DIAGRAM(GUIDE PAGE)

Note: When ordering service parts, be sure to refer to "EXPLODED VIEWS AND PARTS LIST" or "ELECTRICAL PARTS LIST".

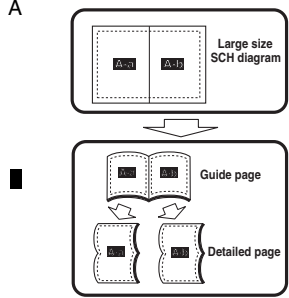

**A-a**

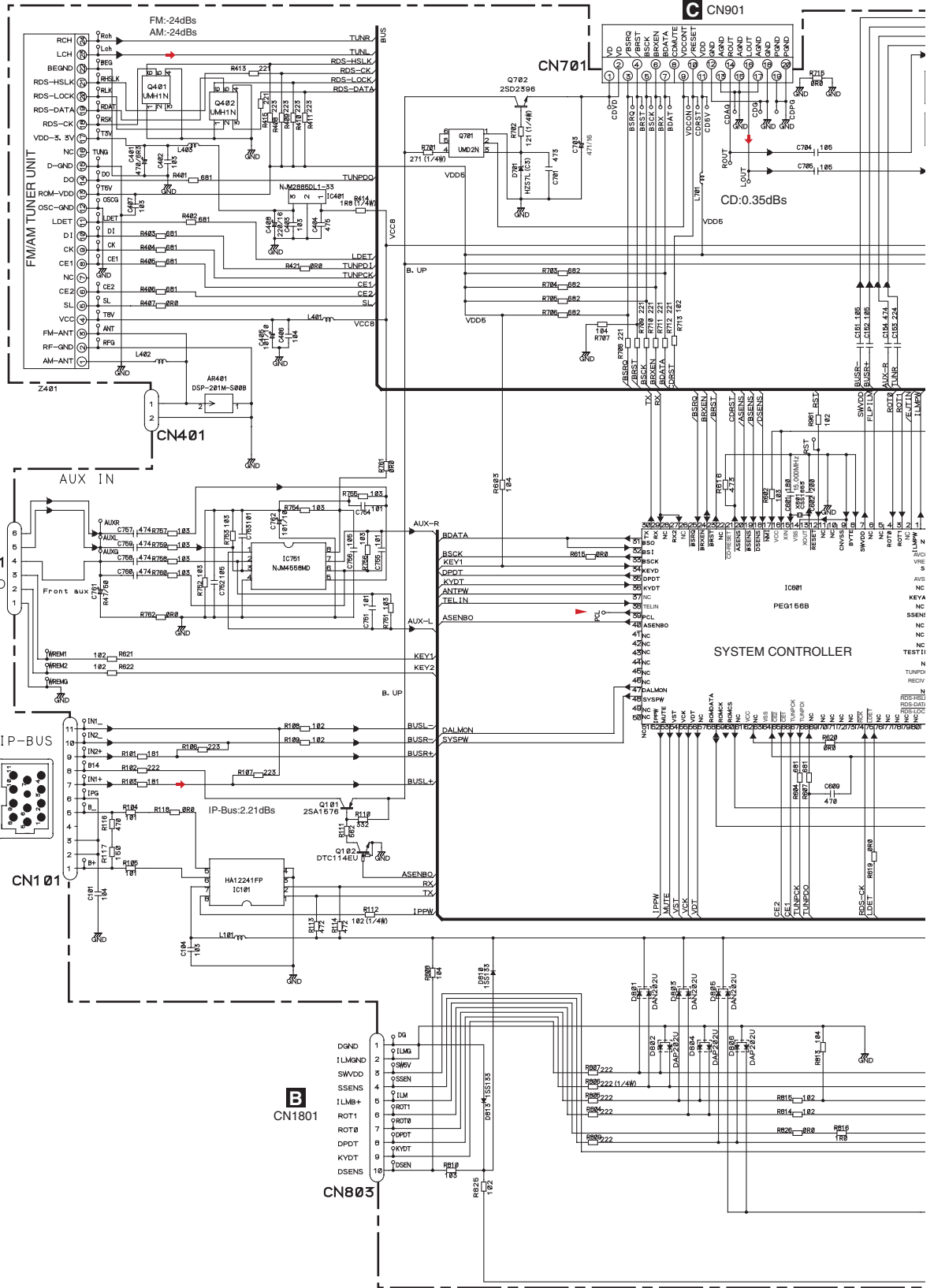
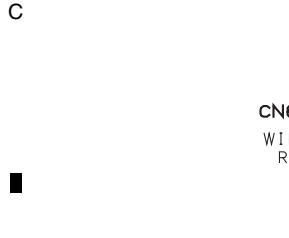

**A**



# 3.3 KEYBOARD UNIT

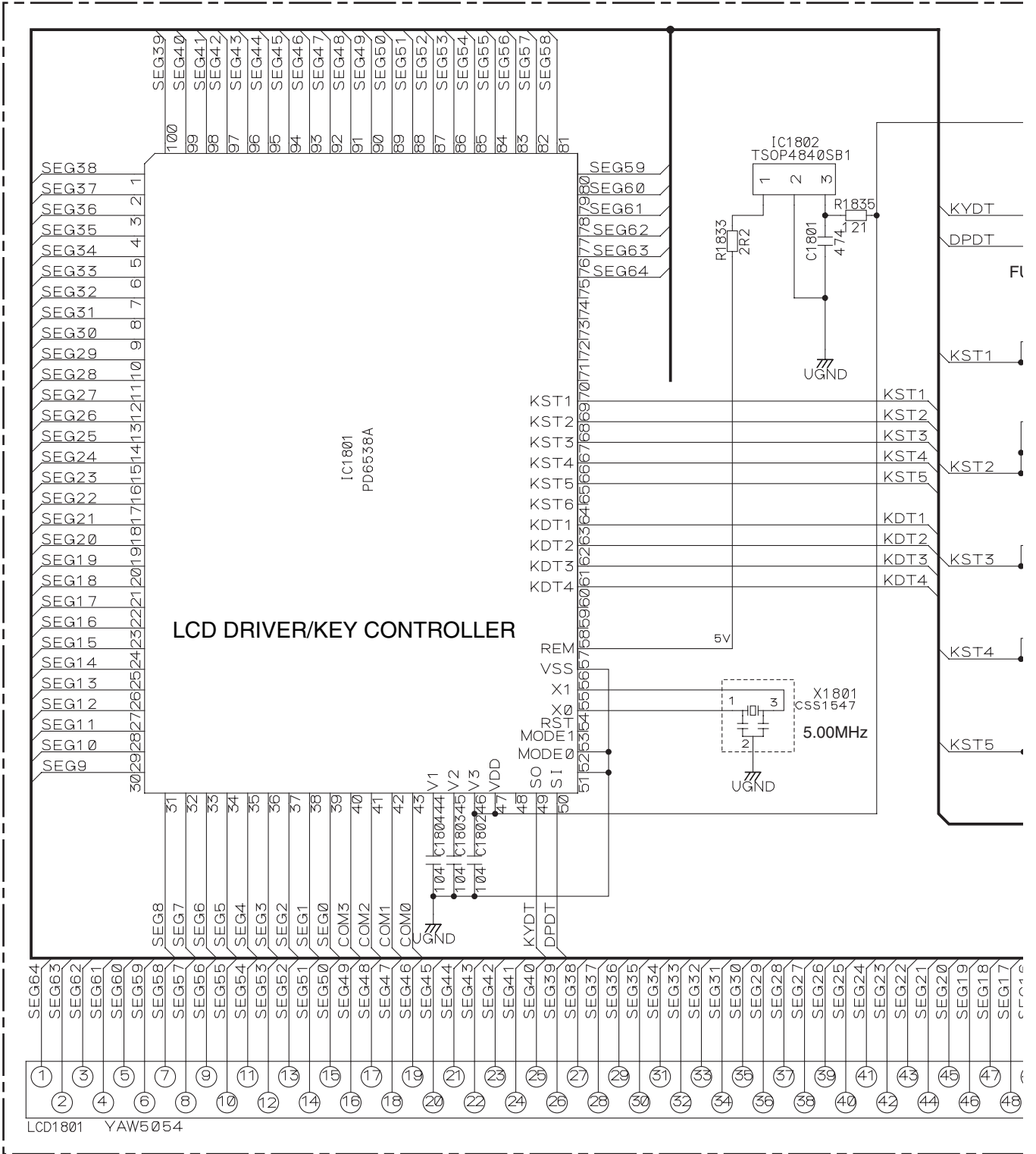

**B**

# B KEYBOARD UNIT

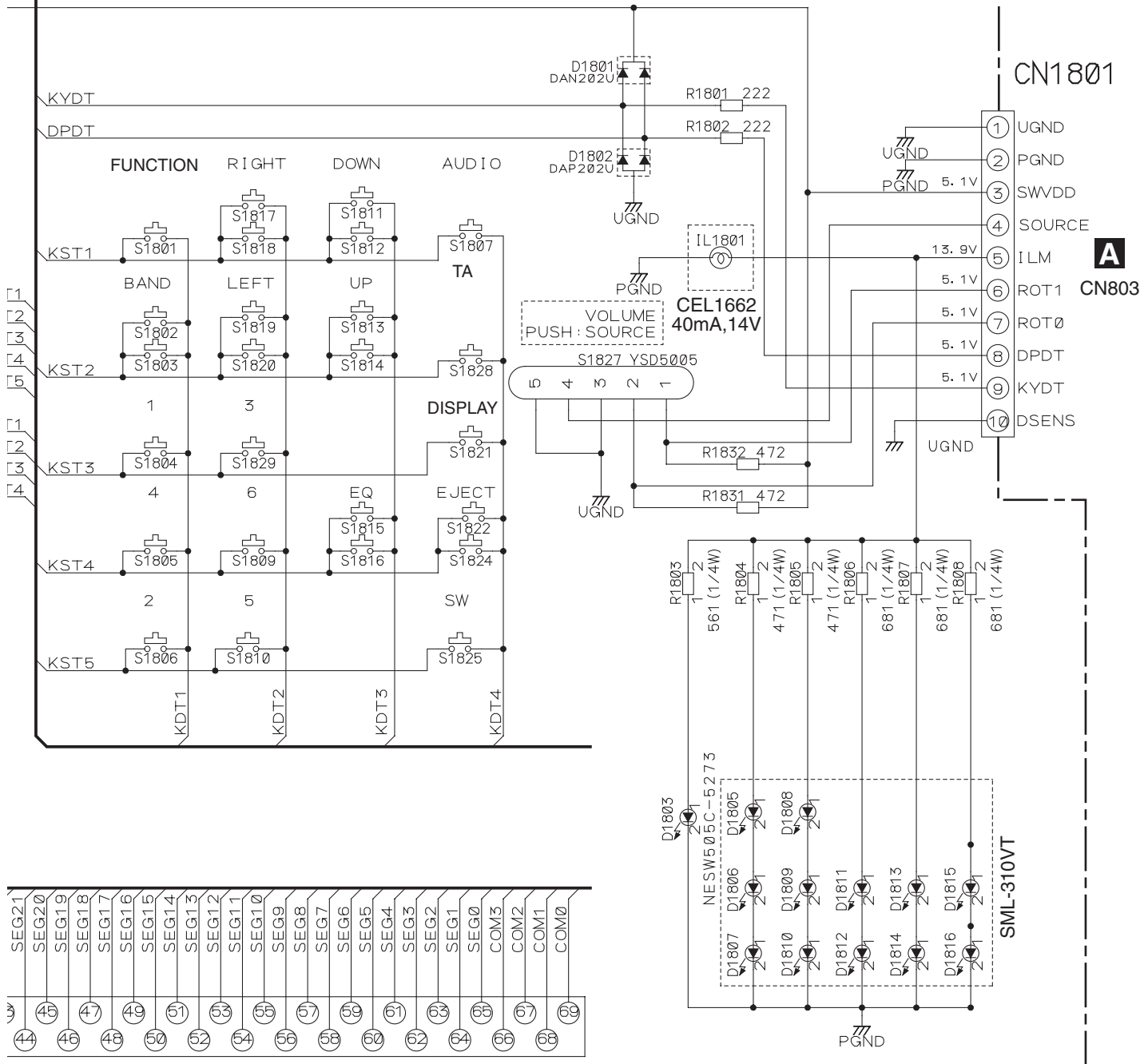

A  
B  
C  
D  
E  
F

B

# 3.4 CD MECHANISM MODULE(GUIDE PAGE)

C-a

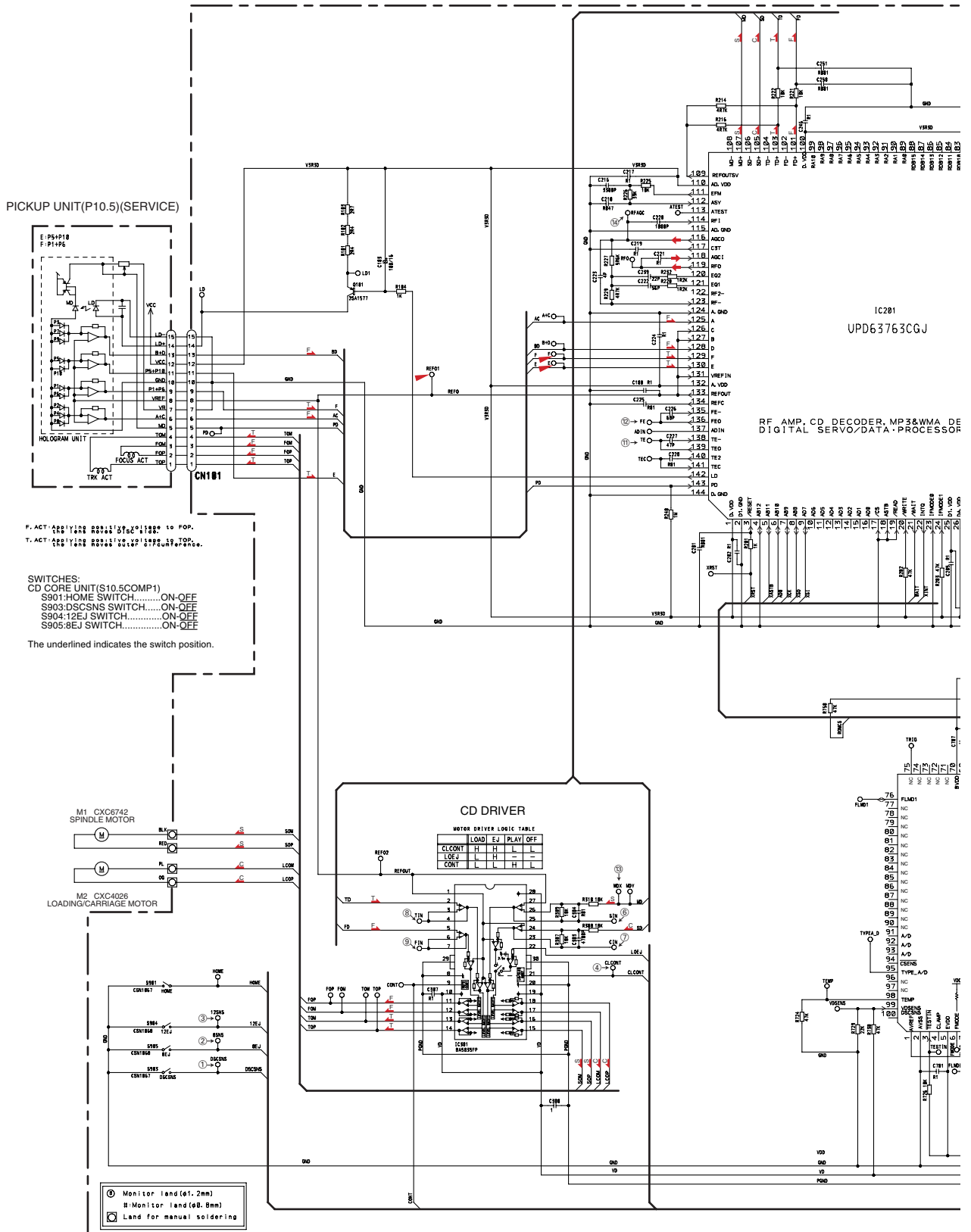

NOTE1) GND ... CD LSI, RFAMP, CPU  
 PGND ... Actuator, Motor Driver  
 AGND ... Audio  
 These GND's are not connected to each other on PCB.  
 PGND is connected to a floating mechanism part by a screw.

C

A  
B  
C  
D  
E  
F

# C-b

A  
B  
C  
D  
E  
F

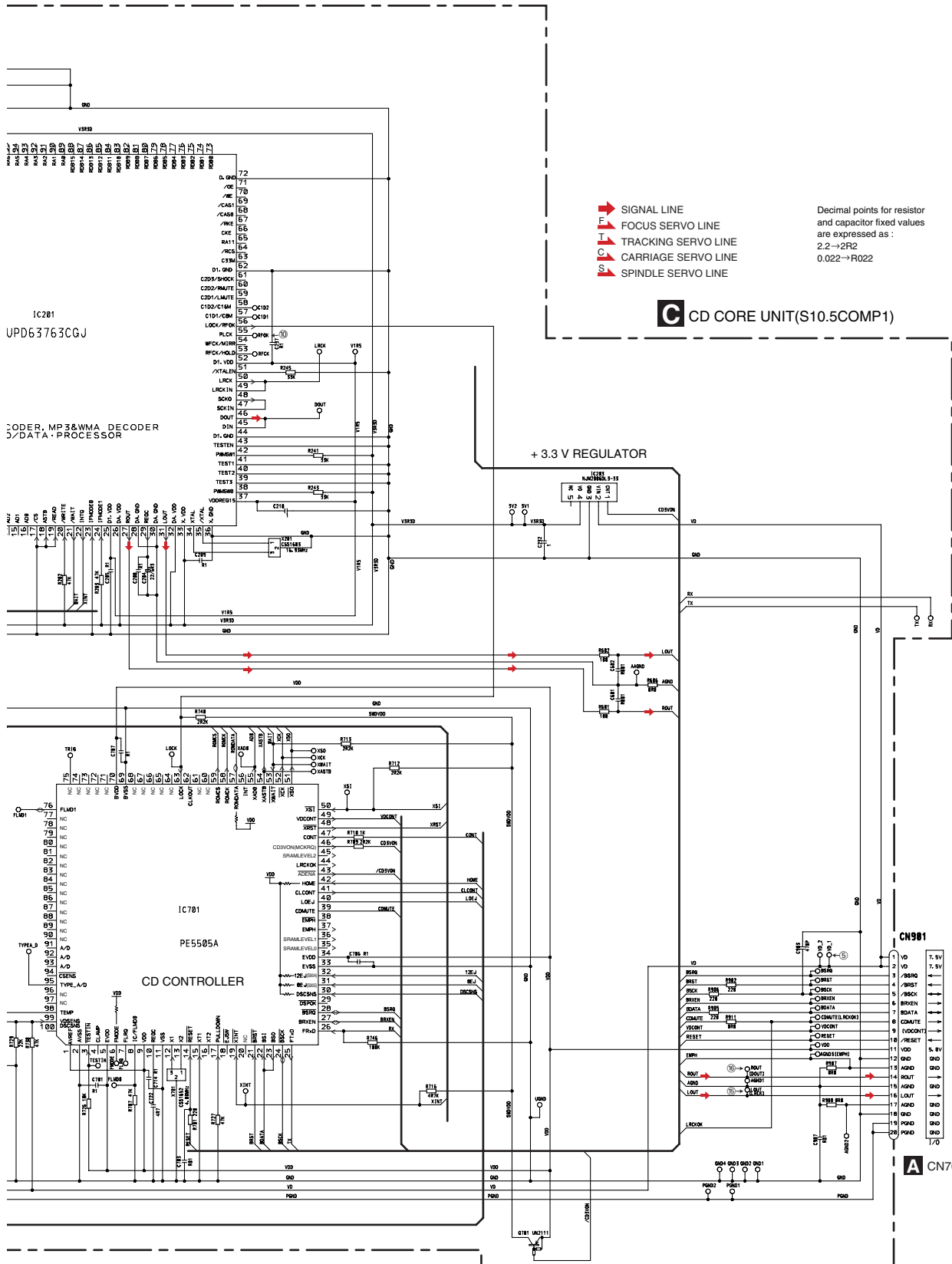

# C

[www.s-manuals.com](http://www.s-manuals.com)