

EAT•N

Aeroquip

Crimp Specifications

For use with Aeroquip Assembly Machines



How To Use This Bulletin

This bulletin contains crimp details for Aeroquip hose and crimp fittings. Specific crimp machine setting instructions are contained in the owner's manual received with each machine.

Fill in the "Crimp Machine Setting" columns for the fittings that you use after consulting the machine calibration instructions in your crimp machine manual.

This bulletin is a comprehensive reference source for owners of Eaton crimp assembly machines. It should be used as a supplement to the owner's manuals developed for Eaton

machines. Checking both sources will make it easier for you to accurately crimp Aeroquip hose and fittings. Specifications subject to change without notice.

WARNING

Eaton fitting tolerances are engineered to match Eaton's Aeroquip hose tolerances. The use of Eaton fittings on hose supplied by other manufacturers and/or the use of Eaton's Aeroquip hose with fittings supplied by other manufacturers may result in the production of unreliable and unsafe hose assemblies and is neither recommended nor authorized by Eaton Corporation or any of its affiliates or subsidiaries.

Failure to follow Eaton process and product instructions and limitations could lead to premature hose assembly failures resulting in property damage, serious injury or death.

The user must exercise extreme care when operating any Eaton assembly equipment with powered moving components. Safety glasses must be worn at all times when using any Eaton assembly equipment.

Read and understand the owners and operators manual before attempting to operate any equipment.

Eaton hereby disclaims any obligation or liability (including incidental and consequential damages) arising from breach of contract, warranty, or tort (under negligence or strict liability theories) should Aeroquip hose, fittings or assembly equipment be used with the hose, fittings or assembly equipment supplied by another manufacturer or in the event that product instructions for each specified hose assembly are not followed.

EATON CUSTOMER SERVICE IS AVAILABLE TO ANSWER ANY QUESTIONS.

Index

HOSE STYLE	CRIMP STYLE	PAGE #	HOSE STYLE	CRIMP STYLE	PAGE #	HOSE STYLE	CRIMP STYLE	PAGE #	HOSE STYLE	CRIMP STYLE	PAGE #	
1503	100R5	16	FC325	Internal Skive	35	FC659	Global TTC12	26	How to Measure Crimp Diameters			4
1529	Global Skive	18	FC350	100R5	17	FC690	Flat	32	Hose Preparation Instructions			
2583	Barrel Field	29	FC355	100R5	17	FC693	Global TTC	26	Global Skive		5	
	Global OTC	27	FC363	Flat	33	FC699	Global OTC	28	Global Nipple with			
2661	Barrel Field	29		Global OTC	28		G. OTC w/FW1097	28	Low Pressure Hose		6	
	Flat Field	31	FC364	Flat	33	FC727	Global Skive	20	Global Spiral			
	Global Nipple with			Global OTC	28		Flat	32	TTC, TTC12 & OTC		7	
	Low Pressure Hose	21	FC372	Flat	14, 32	FC735	Global Skive	19	Barrel & Flat		8	
	Global OTC	27		Global Skive	20		Global TTC	24	Flat (Polyon)		9	
	Global TTC & TTC12	26	FC373	Flat	14, 32	FC736	Global TTC12	26	Flat (PTFE)		10	
2681	Global Skive	18		Global Skive	20		Spiral Single Skive	36	Skive Type - 1 & 2 Piece		11	
2766	Global Skive	18	FC374	Flat	15, 32	FC805	Global TTC12	26	Crimp Equipment Accessories Reference			37
2781	Global Skive	18	FC375	Flat	15, 32	FC806	Global Spiral TTC	34	Crimp Machines and Die Suffix Reference			38-39
2807	Flat	33	FC376	Flat	32	FC807	Flat	33	MatchMate Plus Crimp Machine Target Settings			40-41
FC136	Global TTC12	26		Flat (protective guard collars)	32		Flat (Brass Only)	33	Crimp Machine Capabilities with MatchMate Plus Fittings			42
	Internal Skive	35	FC377	Flat	32	FC839B	Global Skive	18	Tooling Compatibility Chart			42
	Spiral Single Skive	36		Flat (protective guard collars)	32		Global TTC	25				
FC186	Flat	33	FC390	Flat	32	FC849	Global Skive	20				
FC194	Global Skive	18	FC465	Flat	33		Global TTC	25				
FC195	Global Skive	18	FC466	Global Nipple with	21	FC849B	Global Skive	19				
FC211	Barrel Field	29		Low Pressure Hose	27		Global TTC	25				
	Flat Field	31	FC498	Global Nipple with	21	GH120	Global Skive	19				
	Global Skive	18		Low Pressure Hose	21		Global TTC	12, 23				
	Global TTC	22		Global OTC	28	GH194	Global TTC	13, 22				
FC212	Barrel Field	29	FC510	Barrel Field	30		Global Skive	18				
	Flat Field	31		Global Skive	19	GH195	Global TTC	13, 22				
	Global Skive	18		Global TTC	24		Global Skive	18				
	Global TTC	23	FC563	Flat	33	GH466	Global Spiral TTC	34				
FC234	100R5	16	FC579	Global Skive	20	GH493	Global TTC12	13, 26				
FC254	Internal Skive	35		Global TTC	25		Spiral Single Skive	36				
	Spiral Single Skive	36	FC598	Global Nipple with	21	GH506	Global Spiral TTC	34				
	Global Spiral TTC	34		Low Pressure Hose	21	GH663	Barrel Field	29				
FC273	Internal Skive	35		Global OTC	28		Flat Field	31				
	Spiral Single Skive	36	FC606	Internal Skive	35		Global Skive	18				
	Global Spiral TTC	34		Global Spiral TTC	34	GH681	Global Skive	18				
FC273B	Global Spiral TTC	34	FC606B	Global Spiral TTC	34		Global TTC	25				
FC300	100R5	16	FC611	Global TTC	23	GH683	Global TTC	24				
FC310	Barrel Field	30	FC613	Global Skive	18		Global Skive	20				
	Flat Field	31		Global TTC	22	GH781	Global Skive	19				
	Global Skive	19	FC616	Global TTC	25		Global TTC	12, 23				
	Global TTC	24	FC619	Global OTC	27	GH793	Barrel Field	29				
FC318	Barrel Field	29		Global TTC	26		Flat Field	30				
	Flat Field	31	FC636	Global TTC12	26		Global Skive	18				
	Global TTC & TTC12	26	FC639	Global Skive	20		Global TTC	12, 23				
	Global OTC	27		Global TTC	25							
	Global Nipple with		FC640	Global Skive	20							
	Low Pressure Hose	21		Global TTC	25							
FC323	Internal Skive	35										
	Spiral Single Skive	36										
FC324	Internal Skive	35										
	Spiral Single Skive	36										

How to Measure Crimp Diameters

Crimp Diameter Measurement Locations

Diameter measurements are to be taken at the center (top to bottom, side to side) of the specified fitting section.

Use of the Aeroquip Calidapter (part no. FT1297) is recommended for measurement of barrel field crimp diameters. See accessories on page 37.

NOTE: The example and drawing on this page show an Aeroquip MatchMate Plus fitting. Refer to the figures within this document for the correct measurement locations for other types of fittings.

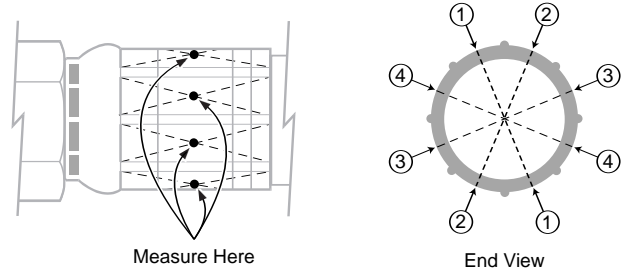

Crimp Diameter Measurement Location
(MatchMate Plus fitting shown)

Crimp Diameter

The crimp diameter is the average of the four diameter measurements around the fitting. These measurements are to be taken at the same relative locations indicated in the illustration above.

NOTE: Aeroquip defines the crimp diameter as the average of four measurements, not just one measurement (see the "End View" illustration above).

$$\frac{\text{Measurement 1} + \text{Measurement 2} + \text{Measurement 3} + \text{Measurement 4}}{4} = \text{Crimp Diameter}$$

Crimp Ovality

Crimp ovality is the largest diameter measurement minus the smallest diameter measurement.

Example

GH781-12 hose with a 1AA12FJ12 fitting measures:

Measurement 1 = 31,57mm (1.243 in.)

Measurement 2 = 31,60mm (1.244 in.)

Measurement 3 = 31,65mm (1.246 in.)

Measurement 4 = 31,65mm (1.246 in.)

$$\text{Crimp Diameter} = \frac{31,51\text{mm (1.243in)} + 31,60\text{mm (1.244in)} + 31,65\text{mm (1.246in)} + 31,65\text{mm (1.246in)}}{4} = 31,62\text{mm (1.245in)}$$

$$\text{Crimp Ovality} = 31,65\text{mm (1.246in)} - 31,57\text{mm (1.243in)} = 0,08\text{mm (0.003in)}$$

Hose Preparation Instructions

Global Skive Crimp Style

Select a matching hose and fitting combination from the current Aeroquip catalog.

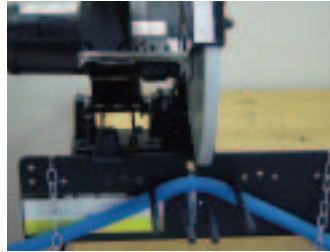

Step 1: Cut the Hose

Cut the hose squarely and to the proper length using a suitable cut off saw. The cut angle must not exceed 5°. Aeroquip recommends using saws similar to the S1104 or FT1500 for large bore and spiral hose, and the FT1258 for FC372 and FC373 hose. Read the saw operation manual for cutting instructions and blade applications.



Step 2: Skive the Hose

Using a suitable skive tool remove the outer hose cover (Do not skive FC372 and FC373). It is crucial that the hose is skived to the proper length and depth and the reinforcement is visible and undamaged around the entire skived area. Improper skiving may lead to fitting/hose separation and lack of weather seal. Refer to the Hose Style Index for proper skive tool and skive length and to Bulletin JA253 for skive tool instructions.



Step 3: Clean the Hose Bore

Using the FT1355-01 Jetcleaner or hose compatible solvent, bottle brush, and/or compressed air, flush contaminants from the hose bore. See operating instructions for the FT1355-01. Follow shop safety rules.



Step 4: Insert the Fitting into the Hose

Place the socket over the hose end until the socket retaining shoulder contacts the hose end. Insert the nipple into the socketed hose until the nipple shoulder bottoms against the hose tube. Slide the socket up against the nipple shoulder or hex and mark the hose cover next to the skirt of the socket.

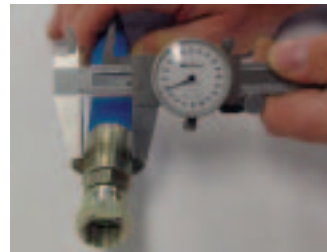

Step 5: Crimp the Fitting

Crimp the fitting then measure the crimp diameter, ovality dimension (see page 2) and inspect the nipple/socket position. Refer to the Crimp Specification bulletin for this information. If the hose mark is not within 3mm (1/8") of the socket skirt, reject the assembly. Refer to your hose in the Hose Style Index for die selection, finished crimp diameter, ovality measurements and operating and crimping instructions.

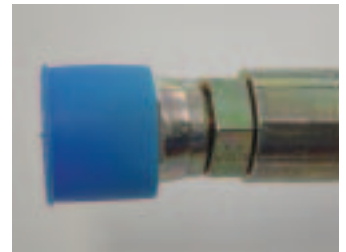

Step 6: Plug or Cap Fitting Ends

Use 23055 dust plugs and caps to protect the fitting threads and seal out contamination until hose assembly is installed

Hose Preparation Instructions

Global Nipple with Low Pressure Hose

Select a matching hose and fitting combination from the current Aeroquip catalog.



Step 1: Cut the Hose

Cut the hose squarely and to the proper length using a suitable cut off saw. The cut angle must not exceed 5°. Aeroquip recommends using saws similar to the S1104 or FT1500 for large bore hoses. Read the saw operation manual for cutting instructions and blade applications.



Step 2: Buffing the Hose

Note: Some hoses require the cover to be buffed. Refer to the appropriate section of the crimp specifications bulletin prior to proceeding. Buff the hose to the proper length and diameter. Remove just enough of the cover to slide the socket on the hose. Do not expose the wire reinforcement. Refer to your hose in the Hose Style Index for more information.



Step 3: Clean the Hose Bore

Using the FT1355-01 Jetcleaner or hose compatible solvent, bottle brush, and/or compressed air, flush contaminants from the hose bore. See operating instructions for the FT1355-01. Follow shop safety rules.



Step 4: Insert the Fitting into the Hose

Place socket over buffed hose end until the socket retaining shoulder contacts the hose end. Insert the nipple into the socketed hose until the nipple shoulder bottoms against the hose tube. Slide the socket up against the nipple shoulder or hex and mark the hose cover next to the skirt of the socket.



Step 5: Crimp the Fitting

Crimp the fitting then measure the crimp diameter, ovality dimension and inspect the nipple/socket position. Refer to the Crimp Specification bulletin for this information. If the hose mark is not within 3mm (1/8") of the socket skirt, reject the assembly. Refer to your hose in the Hose Style Index for die selection, finished crimp diameter, ovality measurements and operating and crimping instructions.

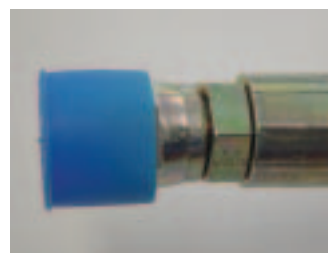

Step 6: Plug or Cap the Fitting Ends

Use 23055 dust plugs and caps to protect the fitting threads and seal out contamination until hose assembly is installed.

Hose Preparation Instructions

Global Spiral TTC, TTC, TTC12 and OTC Crimp Style Fittings

Select a matching hose and fitting combination from the current Aeroquip catalog.

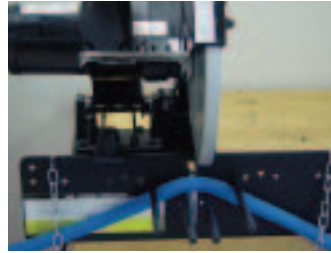

Step 1: Cut the Hose

Cut the hose squarely and to the proper length using a suitable cut off saw. The cut angle must not exceed 5°. Aeroquip recommends using saws similar to the S1104 or FT1500 for large bore and spiral hose. Read the saw operation manual for cutting instructions and blade applications.



Step 2: Clean the Hose Bore

Using the FT1355-01 Jetcleaner or hose compatible solvent, bottle brush, and compressed air, flush contaminants from the hose bore. See operating instructions for the FT1355-01. Follow shop safety rules.

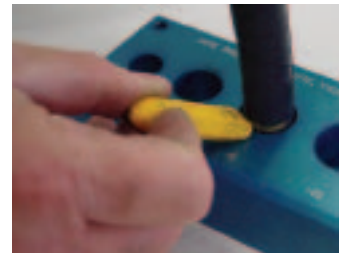

Step 3a: For TTC, TTC12, OTC: Insert the Fitting into the Hose

To determine the fitting insertion depth, use the appropriate FF90308 hose insertion gage or align the end of the hose with the scribe line (located on socket taper) and mark the hose where the gage or socket ends. Insert the fitting into the hose until the bottom of the socket is aligned with the mark on the hose or it bottoms out.



Step 3b: For Spiral TTC: Insert the Fitting into the Hose

To determine the fitting insertion depth, use the appropriate FF90308 hose insertion gage or align the end of the hose with the top of the stenciled part number (located on socket taper) and mark the hose where the gage or socket ends. Insert the fitting into the hose until the bottom of the socket is aligned with the mark on the hose or it bottoms out.



Step 4: Crimp the Fitting

Crimp the fitting then measure the crimp diameter, ovality dimension (see page 2) and inspect the nipple/socket position. Refer to the Crimp Specification bulletin for this information. If the hose mark is not within 3mm (1/8") of the socket skirt reject the assembly. Refer to your hose in the Hose Style Index for die selection, finished crimp diameter, ovality measurements and operating and crimping instructions.



Step 5: Plug or Cap the Fittings Ends

Use 23055 dust plugs and caps to protect the fitting threads and seal out contamination until hose assembly is installed.

Hose Preparation Instructions

Barrel and Flat Field Crimp Style Fittings

Select a matching hose and fitting combination from the current Aeroquip catalog.



Step 1: Cut the Hose

Cut the hose squarely and to the proper length using a suitable cut off saw. The cut angle must not exceed 5°. Aeroquip recommends using saws similar to the S1104. Read the saw operation manual for cutting instructions and blade applications.



Step 2: Clean the Hose Bore

Using the FT1355-01 Jetcleaner or hose compatible solvent, bottle brush, and compressed air, flush contaminants from the hose bore. See operating instructions for the FT1355-01. Follow shop safety rules.



Step 3: Insert the Fitting into the Hose

Insert the fitting into hose until the nipple shoulder bottoms against the hose. Mark the hose where the socket ends with a grease pencil.



Step 4: Crimp the Fitting

Crimp the fitting then measure the crimp diameter, ovality dimension (see page 2) and inspect the nipple/socket position. Refer to the Crimp Specification bulletin for this information. If the hose mark is not within 3mm (1/8") of the socket skirt reject the assembly.

Refer to your hose in the Hose Style Index for die selection, finished crimp diameter, ovality measurements and operating and crimping instructions. Measure Barrell crimp with Aeroquip calidapter (FT1297) and dial calipers or use a thread micrometer. Flat Field measurement does not require calidapters.



Step 5: Plug or Cap the Fitting Ends

Use 23055 dust plugs and caps to protect the fitting threads and seal out contamination until hose assembly is installed.

Hose Preparation Instructions

Swage or Flat Crimp Style Fittings (Polyon)

Select a matching hose and fitting combination from the current Aeroquip catalog.

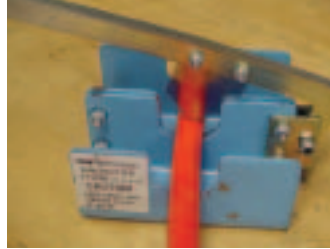

Step 1: Cut the Hose

Cut the hose squarely and to the proper length using the FT1258 cut off tool. The angle of cut must not exceed 5°. Read your cut-off tool operator's manual for cutting instructions.



Step 2: Clean the Hose Bore

Using the FT1355-01 Jetcleaner or hose compatible solvent, bottle brush, and compressed air, flush contaminants from the hose bore. See operating instructions for the FT1355-01. Follow shop safety rules.



Step 3: Insert the Fitting into the Hose

Using the bottom edge of the fitting part number as a reference point, determine the length of the hose to be inserted into the socket. Mark the hose for insertion length with a grease pencil. Lightly lubricate the fitting nipple and push the fitting onto the hose leaving the socket edge even with the mark placed on the hose. Do not bottom the hose in the fitting.



Step 4: Swage the Fitting

Refer to the FT1242 or FT1282 Swage Machine owner's manual and the Hose Style Index for tooling specifications for your swage machine.



Step 5: Crimp the Fitting

Crimp the fitting then measure the crimp diameter, ovality dimensions (see page 2) and inspect the nipple/socket position. Refer to the Crimp Specification bulletin for this information. If the hose mark is not within 3mm (1/8") of the socket skirt, reject the assembly. Refer to your hose in the Hose Style Index for die selection, finished crimp diameter, ovality measurement and operating and crimp instructions.



Step 6: Plug or Cap the Fitting Ends

Use 23055 dust plugs and caps to protect the fitting threads and seal out contamination until hose assembly is installed.

Hose Preparation Instructions

Flat Crimp Style Fittings (PTFE)

Select a matching hose and fitting combination from the current Aeroquip catalog.



Step 1: Cut the Hose

Place 1-1/2 wraps of filament tape around area to be cut. In the center of the taped area, cut the hose squarely and to the proper length using a suitable cut-off saw. Aeroquip recommends using a saw similar to the S1104. When complete, the angle of cut must not exceed 5° and a thin band of tape must be left on the hose to keep the wires in place. Read the saw operation manual for cutting instructions and blade applications.



Step 2: Clean the Hose Bore

Using a hose compatible solvent, bottlebrush, or compressed air, flush contaminants from the hose bore. Follow shop safety rules.



Step 3a: Insert the Fitting into the Hose - Convoluted PTFE

Slide the socket over the hose until the socket bottoms out, or you can see the hose at the top of the socket. Insert the nipple into the hose, turning it inward, until the shoulder comes in contact with the hose. Slide the socket up over the shoulder and flush with the hex. To ensure the fitting does not move during crimping, mark the hose at the bottom of the socket. Swivel Type Fittings: Screw a plug or adapter into the swivel threads and secure the fitting in a vise. Thread the hose onto the nipple until it is snug against the nipple assembly shoulder. Male pipe and flange fittings may be secured in vise without an adapter.



Step 3b: Insert the Fitting into the Hose - Smooth Bore PTFE

Place socket over taped hose end until the socket retaining shoulder contacts the hose end. Insert the nipple into the socketed hose until the nipple bottoms against the hose tube. Slide the socket up against the nipple shoulder and hex and mark the hose cover next to the skirt of the socket.



Step 4: Crimp the Fitting

Crimp the fitting and check the crimp diameter, ovality dimension (see page 2) and inspect the nipple/socket position. Refer to the Crimp Specification bulletin for this information. If hose mark is not within 3mm (1/8") of the socket skirt, reject the assembly. PTFE hose requires a crimp machine with a positive backstop. Refer to your hose in the Hose Style Index for die selection, finished crimp diameter, ovality measurements and operating and crimping instructions.



Step 5: Plug or Cap the Fitting Ends

Use 23055 dust plugs and caps to protect the fitting threads and seal out contamination until hose assembly is installed.

Hose Preparation Instructions

Skive Type - 1 and 2 Piece Crimp Style Fittings

Select a matching hose and fitting combination from the current Aeroquip catalog.



Step 1: Cut the Hose

Cut the hose squarely and to the proper length using a suitable cut off saw. The cut angle must not exceed 5°. Aeroquip recommends using saws similar to the S1104 or FT1500 for large bore and spiral hose. Read the saw operation manual for cutting instructions and blade applications.



Step 2: Skive the Hose

Using a suitable skive tool, remove the outer hose cover. It is crucial that the hose is skived to the proper length and depth and the reinforcement is visible all around the circumference of the hose and undamaged around the entire skived area. Improper skiving may lead to fitting/hose separation and lack of weather seal. Refer to your hose in the Hose Style Index for proper skive tool and skive length. Refer to Bulletin JA253 for skive tool instructions.



Step 3: Clean the Hose Bore

Using the FT1355-01 Jetcleaner or hose compatible solvent, bottle brush, and/or compressed air, flush contaminants from the hose bore. See operating instructions for the FT1355-01. Follow shop safety rules.



Step 4a: One Piece Fitting: Insert the Fitting into the Hose

To determine the fitting insertion depth, align the end of the hose with the top of the stenciled part number (located on socket taper) and mark the hose where the socket ends. Insert the fitting into the hose until the bottom of the socket is aligned with the mark on the hose or it bottoms out.



Step 4b: Two Piece Fitting: Insert the Fitting into the Hose

Place the socket over the skived hose end until the socket retaining shoulder contacts the hose end. Insert the nipple into the socketed hose until the nipple shoulder bottoms against the hose tube. Slide the socket up against the nipple shoulder or hex and mark the hose cover next to the skirt of the socket.



Step 5: Crimp the Fitting

Crimp the fitting then measure the crimp diameter, ovality dimension (see page 2) and inspect the nipple/socket position. Refer to the Crimp Specification bulletin for this information. If the hose mark is not within 3mm (1/8") of the socket skirt, reject the assembly. Refer to your hose in the Hose Style Index for die selection, finished crimp diameter, ovality measurements and operating and crimping instructions.



Step 6: Plug or Cap the Fitting Ends

Use 23055 dust plugs and caps to protect the fitting threads and seal out contamination until hose assembly is installed.

ET1000

MatchMate™ Tooling

* Max. crimp ovality .20 mm/.008 in.

** Die ring adapter part number =
ET1000AR-001.

Figure 5

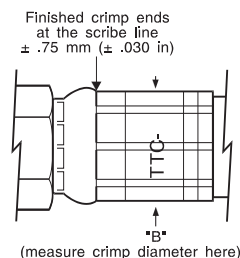

HOSE STYLE	SOCKET PART #	COLLET PART #	SPACER RING	SPACER RING PART #	FLAT SIDE (UP/DOWN)	CRIMP DIA. B*	SEE FIG. #	DIE RING ADAPTER REQ'D**
						± .015 mm ± .006 in		
GH781-								
GH781-04	TTC	ET400DC-M150S	Yellow	ET1000SR-M115D	Up	16.89 mm 0.665 in	5	Yes
GH781-06	TTC	ET400DC-M195S	Black	ET1000SR-M265D	Down	20.70 mm 0.815 in	5	Yes
GH781-08	TTC	ET400DC-M230S	Lt. Green	ET1000SR-M190D	Up	24.77 mm 0.975 in	5	Yes
GH781-10	TTC	ET1000DC-M250S	Black	ET1000SR-M265D	Up	28.32 mm 1.115 in	5	No
GH781-12	TTC	ET1000DC-M295S	Black	ET1000SR-M265D	Down	31.62 mm 1.245 in	5	No
GH781-16	TTC	ET1000DC-M390S	Orange	ET1000SR-M315A	Up	39.75 mm 1.565 in	5	No
GH781-20	TTC	ET1000DC-M475S	Orange	ET1000SR-M315A	Up	48.26 mm 1.900 in	5	No
GH793-								
GH793-04	TTC	ET400DC-M150S	Lt. Green	ET1000SR-M190D	Up	17.27 mm 0.680 in	5	Yes
GH793-06	TTC	ET400DC-M195S	Yellow	ET1000SR-M115D	Up	21.21 mm 0.835 in	5	Yes
GH793-08	TTC	ET400DC-M230S	Black	ET1000SR-M265D	Up	25.15 mm 0.990 in	5	Yes
GH793-10	TTC	ET1000DC-M250S	Silver	ET1000SR-M395D	Up	28.70 mm 1.130 in	5	No
GH793-12	TTC	ET1000DC-M295S	Black	ET1000SR-M265D	Up	32.51 mm 1.280 in	5	No
GH793-16	TTC	ET1000DC-M390S	Lt. Green	ET1000SR-M190D	Up	41.40 mm 1.630 in	5	No
GH793-20	TTC	ET1000DC-M475S	Yellow	ET1000SR-M115D	Up	49.78 mm 1.960 in	5	No
GH120-								
GH120-04	TTC	ET400DC-M150S	Black	ET1000SR-M265D	Down	16.26 mm 0.640 in	5	Yes
GH120-06	TTC	ET400DC-M195S	Tan	T-400-112	Up	20.32 mm 0.800 in	5	Yes
GH120-08	TTC	ET400DC-M230S	Lt. Green	ET1000SR-M190D	Up	24.77 mm 0.975 in	5	Yes
GH120-10	TTC	ET1000DC-M250S	Black	ET1000SR-M265D	Up	28.32 mm 1.115 in	5	No
GH120-12	TTC	ET1000DC-M295S	Black	ET1000SR-M265D	Down	31.62 mm 1.245 in	5	No
GH120-16	TTC	ET1000DC-M390S	Orange	ET1000SR-M315A	Up	39.75 mm 1.565 in	5	No
GH120-20	TTC	ET1000DC-M475S	Orange	ET1000SR-M315A	Up	48.26 mm 1.900 in	5	No

ET1000

MatchMate™ Tooling

* Max. crimp ovality .20 mm/.008 in.

** Die ring adapter part number = ET1000AR-001.

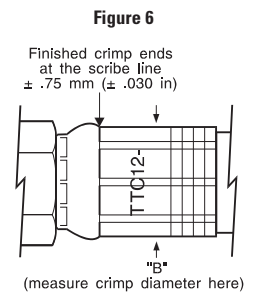
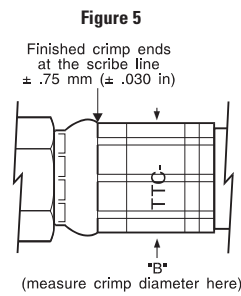

HOSE STYLE	SOCKET PART #	COLLET PART #	SPACER RING	SPACER RING PART #	FLAT SIDE (UP/DOWN)	CRIMP DIA. B*	SEE FIG. #	DIE RING ADAPTER REQ'D**
						± .015 mm ± .006 in		
GH663-								
GH663-04	TTC	ET400DC-M150S	Purple	ET1000SR-M100A	Up	15.75 mm 0.620 in	5	Yes
GH663-06	TTC	ET400DC-M195S	Purple	ET1000SR-M100A	Up	19.94 mm 0.785 in	5	Yes
GH663-08	TTC	ET400DC-M230S	Black	ET1000SR-M265D	Down	23.88 mm 0.940 in	5	Yes
GH663-10	TTC	ET1000DC-M250S	Purple	ET1000SR-M100A	Up	26.80 mm 1.055 in	5	No
GH663-12	TTC	ET1000DC-M295S	Yellow	ET1000SR-M115D	Up	31.75 mm 1.250 in	5	No
GH663-16	TTC	ET1000DC-M390S	Purple	ET1000SR-M100A	Up	40.39 mm 1.590 in	5	No
GH663-20	TTC	ET1000DC-M430S	Black	ET1000SR-M265D	Up	46.00 mm 1.811 in	5	No
GH195-								
GH195-04	TTC	ET400DC-M150S	Yellow	ET1000SR-M115D	Up	16.89 mm 0.665 in	5	Yes
GH195-06	TTC	ET400DC-M195S	Yellow	ET1000SR-M115D	Up	21.21 mm 0.835 in	5	Yes
GH195-08	TTC	ET400DC-M230S	Black	ET1000SR-M265D	Up	25.15 mm 0.990 in	5	Yes
GH195-10	TTC	ET1000DC-M250S	Silver	ET1000SR-M395D	Up	28.70 mm 1.130 in	5	No
GH195-12	TTC	ET1000DC-M295S	Black	ET1000SR-M265D	Up	32.51 mm 1.280 in	5	No
GH195-16	TTC	ET1000DC-M390S	Black	ET1000SR-M265D	Up	41.66 mm 1.640 in	5	No
GH195-20	TTC	ET1000DC-M475S	Silver	ET1000SR-M395D	Up	50.80 mm 2.000 in	5	No
GH194-								
GH194-04	TTC	ET400DC-M150S	Purple	ET1000SR-M100A	Up	15.75 mm 0.620 in	5	Yes
GH194-06	TTC	ET400DC-M195S	Green	T-400-37	Up	19.56 mm 0.770 in	5	Yes
GH194-08	TTC	ET400DC-M230S	Black	ET1000SR-M265D	Down	23.88 mm 0.940 in	5	Yes
GH194-10	TTC	ET1000DC-M250S	Purple	ET1000SR-M100A	Up	26.80 mm 1.055 in	5	No
GH194-12	TTC	ET1000DC-M295S	Yellow	ET1000SR-M115D	Up	31.75 mm 1.250 in	5	No
GH194-16	TTC	ET1000DC-M390S	Purple	ET1000SR-M100A	Up	40.39 mm 1.590 in	5	No
GH194-20	TTC	ET1000DC-M430S	Black	ET1000SR-M265D	Up	45.72 mm 1.800 in	5	No
GH493-								
GH493-06	TTC12	ET400DC-M230S	Red	T-400-38	Up	22.76 mm 0.896 in	6	Yes
GH493-08	TTC12	ET1000DC-M250S	Lt. Green	ET1000SR-M190D	Up	27.81 mm 1.095 in	6	No
GH493-10	TTC12	ET1000DC-M295S	Orange	ET1000SR-M315A	Up	30.48 mm 1.200 in	6	No
GH493-12	TTC12	ET1000DC-M320S	Black	ET1000SR-M265D	Down	34.42 mm 1.355 in	6	No
GH493-16	TTC12	ET1000DC-M430S	Orange	ET1000SR-M315A	Up	43.82 mm 1.725 in	6	No

ET1000

Polyon Tooling

* Max. crimp ovality .20 mm/.008 in.

** Die ring adapter part number =
ET1000AR-001.

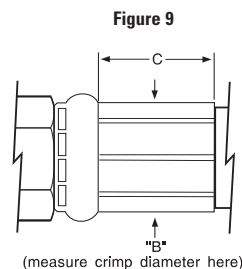

HOSE STYLE	SOCKET PART #	COLLET PART #	SPACER RING	SPACER RING PART #	FLAT SIDE (UP/DOWN)	CRIMP DIA. B	CRIMP LENGTH C	SEE FIG. #	DIE RING ADAPTER REQ'D
						± .12 mm ± .005 in	± .38 mm ± .015 in		
FC372-									
FC372-02	FC1006	ET1000DC-M095S	Red	T-400-38	Up	9.52 mm 0.375 in	11.94 mm .470 in	9	Yes
FC372-03	FC1006	T-400-2C	Red	T-400-38	Up	12.75 mm 0.502 in	19.94 mm .785 in	9	Yes
FC372-04	FC1006	T-400-109C	Green	T-400-37	Up	14.47 mm 0.570 in	22.48 mm .885 in	9	Yes
FC372-05	FC1006	T-400-109C	Black/Red	T-400-47R	Up	16.26 mm 0.640 in	27.94 mm 1.100 in	9	Yes
FC372-06	FC1006	T-400-122C	Tan	T-400-112	Up	17.90 mm 0.705 in	32.39 mm 1.275 in	9	Yes
FC372-08	FC1006	ET1000DC-M215S	Magenta	ET1000SR-M215A	Up	21.71 mm 0.855 in	37.47 mm 1.475 in	9	Yes
FC372-12	FC1006	T-420-30C	Purple	ET1000SR-M100A	Up	28.19 mm 1.110 in	38.10 mm 1.500 in	9	No
FC372-16	FC1006	ET1000DC-M320S	Magenta	ET1000SR-M215A	Up	33.78 mm 1.330 in	51.44 mm 2.025 in	9	No
FC373-									
FC373-02	FC1006	ET1000DC-M095S	Red	T-400-38	Up	9.52 mm 0.375 in	11.94 mm .470 in	9	Yes
FC373-03	FC1006	T-400-2C	Red	T-400-38	Up	12.75 mm 0.502 in	19.94 mm .785 in	9	Yes
FC373-04	FC1006	T-400-109C	Green	T-400-37	Up	14.47 mm 0.570 in	22.48 mm .885 in	9	Yes
FC373-05	FC1006	T-400-109C	Black/Red	T-400-47R	Up	16.26 mm 0.640 in	27.94 mm 1.100 in	9	Yes
FC373-06	FC1006	T-400-122C	Tan	T-400-112	Up	17.90 mm 0.705 in	32.39 mm 1.275 in	9	Yes
FC373-08	FC1006	ET1000DC-M215S	Magenta	ET1000SR-M215A	Up	21.71 mm 0.855 in	37.47 mm 1.475 in	9	Yes
FC373-12	FC1006	T-420-30C	Purple	ET1000SR-M100A	Up	28.19 mm 1.110 in	38.10 mm 1.500 in	9	No
FC373-16	FC1006	ET1000DC-M320S	Magenta	ET1000SR-M215A	Up	33.78 mm 1.330 in	51.44 mm 2.025 in	9	No

ET1000

Polyon Tooling

* Max. crimp ovality .20 mm/.008 in.

** Die ring adapter part number = ET1000AR-001.

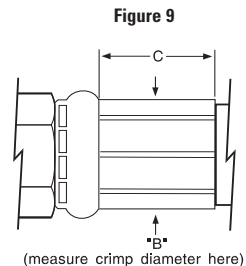

HOSE STYLE	SOCKET PART #	COLLET PART #	SPACER RING	SPACER RING PART #	FLAT SIDE (UP/DOWN)	CRIMP DIA. B	CRIMP LENGTH C	SEE FIG. #	DIE RING ADAPTER REQ'D
						± .12 mm ± .005 in	± .38 mm ± .015 in		
FC374-									
FC374-03	FC1006	T-400-2C	Red	T-400-38	Up	12.75 mm 0.502 in	19.94 mm .785 in	9	Yes
FC374-04	FC1006	T-400-109C	Red	T-400-38	Up	14.22 mm 0.560 in	22.48 mm .885 in	9	Yes
FC374-06	FC1006	T-400-122C	Purple	ET1000SR-M100A	Up	17.65 mm 0.695 in	32.39 mm 1.275 in	9	Yes
FC374-08	FC1006	ET1000DC-M215S	Red	T-400-38	Up	21.46 mm 0.845 in	37.47 mm 1.475 in	9	Yes
FC374-12	FC1006	T-420-30C	Red	T-400-38	Up	27.68 mm 1.090 in	38.10 mm 1.500 in	9	No
FC374-16	FC1006	ET1000DC-M320S	Magenta	ET1000SR-M215A	Up	33.78 mm 1.330 in	51.44 mm 2.025 in	9	No
FC375-									
FC375-03	FC1006	T-400-2C	Red	T-400-38	Up	12.75 mm 0.502 in	19.94 mm .785 in	9	Yes
FC375-04	FC1006	T-400-109C	Red	T-400-38	Up	14.22 mm 0.560 in	22.48 mm .885 in	9	Yes
FC375-06	FC1006	T-400-122C	Purple	ET1000SR-M100A	Up	17.65 mm 0.695 in	32.39 mm 1.275 in	9	Yes
FC375-08	FC1006	ET1000DC-M215S	Red	T-400-38	Up	21.46 mm 0.845 in	37.47 mm 1.475 in	9	Yes
FC375-12	FC1006	T-420-30C	Red	T-400-38	Up	27.68 mm 1.090 in	38.10 mm 1.500 in	9	No
FC375-16	FC1006	ET1000DC-M320S	Magenta	ET1000SR-M215A	Up	33.78 mm 1.330 in	51.44 mm 2.025 in	9	No

100R5

Crimp Die Part Numbers

FT1307-200-R5-**-04 through -32)

FT1330-275-R5-**-04 through -20)

FT1380-275-R5-**-04 through -20)

* Max. crimp ovality .20 mm/.008 in.

**Must be replaced by appropriate dash size when ordering.

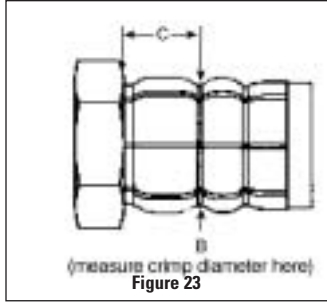

HOSE DASH SIZE	SOCKET PART #	CRIMP DIA. B*	CRIMP LENGTH C	DIE SUFFIX #	SEE FIGURE #	CRIMP MACHINE SETTING
		± .15 mm ± .006 in	± .38 mm ± .015 in			
1503						
-04	FW1186	12.55 mm 0.494 in	13.10 mm 0.516 in	-R5-04	23	
-05	FLH186	13.35 mm 0.525 in	13.10 mm 0.516 in	-R5-05	23	
-06	FLH186	16.35 mm 0.644 in	13.10 mm 0.516 in	-R5-06	23	
-08	FLH186	18.35 mm 0.722 in	13.10 mm 0.516 in	-R5-08	23	
-10	FLH186	22.05 mm 0.868 in	13.10 mm 0.516 in	-R5-10	23	
-12	FLH186	25.95 mm 1.022 in	13.40 mm 0.528 in	-R5-12	23	
-16	FLH186	30.55 mm 1.203 in	16.80 mm 0.661 in	-R5-16	23	
-20	FLH186	36.35 mm 1.431 in	18.40 mm 0.724 in	-R5-20	23	
-24	FLH186	41.65 mm 1.640 in	19.30 mm 0.760 in	-R5-24	23	
-32	FLH186	55.55 mm 2.187 in	25.90 mm 1.020 in	-R5-32	23	
FC234						
-05	FLH186	14.05 mm 0.553 in	13.10 mm 0.516 in	-R5-05	23	
-06	FLH186	17.05 mm 0.671 in	13.10 mm 0.516 in	-R5-06	23	
-08	FLH186	19.05 mm 0.750 in	13.10 mm 0.516 in	-R5-08	23	
-10	FLH186	23.35 mm 0.919 in	13.10 mm 0.516 in	-R5-10	23	
-12	FLH186	26.25 mm 1.034 in	13.40 mm 0.528 in	-R5-12	23	
-16	FLH186	30.55 mm 1.203 in	16.80 mm 0.661 in	-R5-16	23	
FC300						
-04	FLH186	12.55 mm 0.494 in	13.10 mm 0.516 in	-R5-04	23	
-05	FLH186	13.55 mm 0.533 in	13.10 mm 0.516 in	-R5-05	23	
-06	FLH186	16.65 mm 0.656 in	13.10 mm 0.516 in	-R5-06	23	
-08	FLH186	18.75 mm 0.738 in	13.10 mm 0.516 in	-R5-08	23	
-10	FLH186	22.35 mm 0.880 in	13.10 mm 0.516 in	-R5-10	23	
-12	FLH186	26.15 mm 1.030 in	13.40 mm 0.528 in	-R5-12	23	
-16	FLH186	30.55 mm 1.203 in	16.80 mm 0.661 in	-R5-16	23	
-20	FLH186	36.25 mm 1.427 in	18.40 mm 0.724 in	-R5-20	23	
-24	FLH186	41.85 mm 1.648 in	19.30 mm 0.760 in	-R5-24	23	
-32	FLH186	55.05 mm 2.167 in	25.90 mm 1.020 in	-R5-32	23	

Crimp Die Part Numbers

FT1307-200-R5-** (-04 through -32)

FT1330-275-R5-** (-04 through -20)

FT1380-275-R5-** (-04 through -20)

* Max. crimp ovality .20 mm/.008 in.

**Must be replaced by appropriate dash size when ordering.

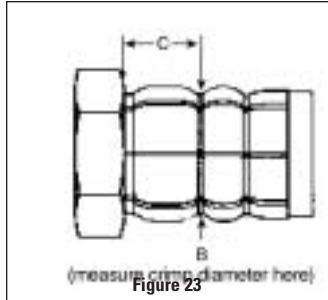

HOSE DASH SIZE	SOCKET PART #	CRIMP DIA. B*	CRIMP LENGTH C	DIE SUFFIX #	SEE FIGURE #	CRIMP MACHINE SETTING
		± .15 mm ± .006 in	± .38 mm ± .015 in			
FC350						
-04	FW1186	12.55 mm 0.494 in	13.10 mm 0.516 in	-R5-04	23	
-05	FLH186	13.65 mm 0.537 in	13.10 mm 0.516 in	-R5-05	23	
-06	FLH186	16.35 mm 0.644 in	13.10 mm 0.516 in	-R5-06	23	
-08	FLH186	0.734 mm 18.65 in	13.10 mm 0.516 in	-R5-08	23	
-10	FLH186	22.35 mm 0.880 in	13.10 mm 0.516 in	-R5-10	23	
-12	FLH186	26.15 mm 1.030 in	13.40 mm 0.528 in	-R5-12	23	
-16	FLH186	30.55 mm 1.203 in	16.80 mm 0.661 in	-R5-16	23	
-20	FLH186	36.35 mm 1.431 in	18.40 mm 0.724 in	-R5-20	23	
-24	FLH186	42.35 mm 1.667 in	19.30 mm 0.760 in	-R5-24	23	
FC355						
-04	FLH186	12.55 mm 0.494 in	13.10 mm 0.516 in	-R5-04	23	
-05	FLH186	13.55 mm 0.533 in	13.10 mm 0.516 in	-R5-05	23	
-06	FLH186	16.55 mm 0.652 in	13.10 mm 0.516 in	-R5-06	23	
-08	FLH186	18.65 mm 0.734 in	13.10 mm 0.516 in	-R5-08	23	
-10	FLH186	22.35 mm 0.880 in	13.10 mm 0.516 in	-R5-10	23	
-12	FLH186	26.15 mm 1.030 in	13.40 mm 0.528 in	-R5-12	23	
-16	FLH186	30.55 mm 1.203 in	16.80 mm 0.661 in	-R5-16	23	
-20	FLH186	36.75 mm 1.447 in	18.40 mm 0.724 in	-R5-20	23	
-24	FLH186	42.25 mm 1.663 in	19.30 mm 0.760 in	-R5-24	23	
-32	FLH186	55.55 mm 2.187 in	25.90 mm 1.020 in	-R5-32	23	

Global Skive Crimp Style

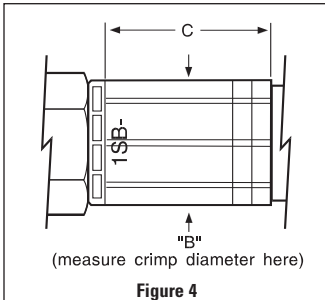
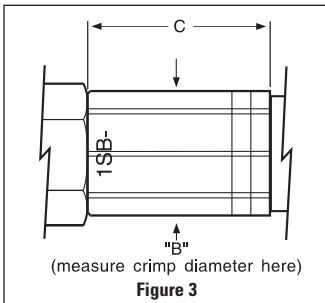
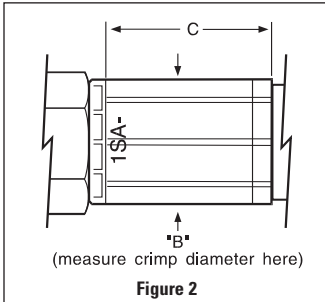
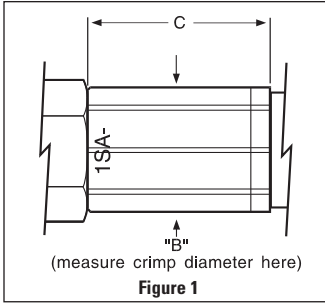
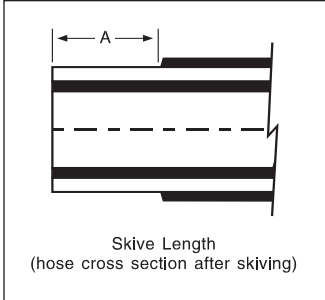

* Max. crimp ovality .20 mm/.008 in.

** Crimp full length of socket.

1 -20 Global sockets must be pre-crimped to nipple to achieve complete crimp on FT1330 and FT1380 machines.

2 FT1209-200-23 not approved.

3 Crimp diameter for 2766-4 only

HOSE DASH SIZE	SOCKET PART #	SKIVE LENGTH A	CRIMP DIA. B*	CRIMP LENGTH C	DIE SUFFIX #	SEE FIGURE #	CRIMP MACHINE SETTING
		± .50 mm ± .020 in	± .15 mm ± .006 in	± .76 mm ± .030 in			
GH194, GH663, 2681, FC194, FC211, FC613							
-03	1SA3	14.00 mm .550 in	12.83 mm .505 in	**	-M120 -90	1	
-04	1SA4	16.30 mm .640 in	15.75 mm .620 in	**	-M150 -2	1	
-05	1SA5	18.30 mm .720 in	17.78 mm .700 in	**	-M180 -93	1	
-06	1SA6	16.50 mm .650 in	20.83 mm .820 in	**	-M210 -3	1	
-08	1SA8	20.00 mm .790 in	23.24 mm .915 in	**	-M210 -4	1	
-10	1SA10	21.00 mm .830 in	26.80 mm 1.055 in	**	-M240 -5	1	
-12	1SA12	21.60 mm .850 in	30.73 mm 1.210 in	**	-M280 -6	1	
-16	1SA16	25.90 mm 1.020 in	38.10 mm 1.500 in	**	-M370 -8	1	
-20	1SA20	30.70 mm 1.210 in	47.75 mm 1.880 in	**	-M465 -9	1	
-20 ¹	1SA20 Pre-Crimped	30.70 mm 1.210 in	47.75 mm 1.880 in	38.10 mm 1.500 in	-M465 -9	2	
-24	1SA24	32.80 mm 1.290 in	55.37 mm 2.180 in	**	-M550 -11	1	
-32	1SA32	33.00 mm 1.300 in	70.87 mm 2.790 in	**	-M690 -17 -23 ²	1	
GH195, GH793, 1529, 2766³, 2781, FC195, FC212							
-04	1SB4	16.30 mm .640 in	15.88 mm .625 in 16.38 mm ³ .645 in ³	**	-M150 -2	3	
-05	1SB5	19.30 mm .760 in	17.78 mm .700 in	**	-M180 -93	3	
-06	1SB6	16.50 mm .650 in	20.57 mm .810 in	**	-M210 -3	3	
-08	1SB8	20.00 mm .790 in	23.24 mm .915 in	**	-M210 -4	3	
-10	1SB10	21.00 mm .830 in	26.80 mm 1.055 in	**	-M240 -5	3	
-12	1SB12	21.60 mm .850 in	30.73 mm 1.210 in	**	-M280 -6	3	
-16	1SB16	25.90 mm 1.020 in	38.10 mm 1.500 in	**	-M370 -8	3	
-20	1SB20	30.70 mm 1.210 in	47.75 mm 1.880 in	**	-M465 -9	3	
-20 ¹	1SB20 Pre-Crimped	30.70 mm 1.210 in	47.75 mm 1.880 in	38.10 mm 1.500 in	-M465 -9	4	
-24	1SB24	32.80 mm 1.290 in	55.37 mm 2.180 in	**	-M550 -11	3	
-32	1SB32	33.00 mm 1.300 in	70.87 mm 2.790 in	**	-M690 -17 -23 ²	3	
GH681							
-4	1SA4	16.30 mm .640 in	15.37 mm .605 in	**	-M150 -2	1	
-6	1SA6	16.50 mm .650 in	20.83 mm .820 in	**	-M210 -3	1	
-8	1SA8	20.10 mm .790 in	23.24 mm .915 in	**	-M210 -4	1	

Global Skive Crimp Style

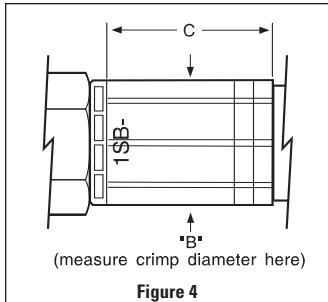
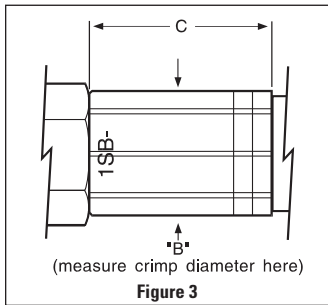
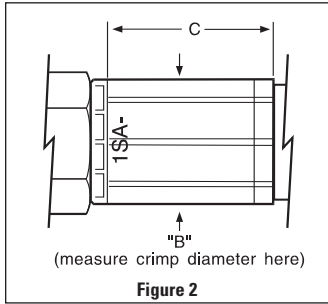
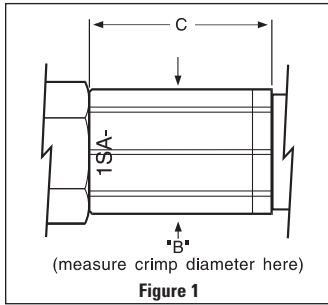
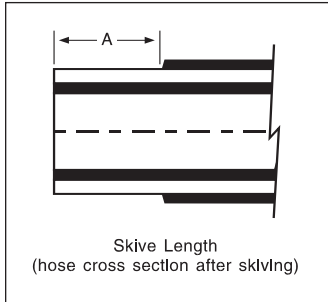

HOSE DASH SIZE	SOCKET PART #	SKIVE LENGTH A	CRIMP DIA. B*	CRIMP LENGTH C	DIE SUFFIX #	SEE FIGURE #	CRIMP MACHINE SETTING
		± .50 mm ± .020 in	± .15 mm ± .006 in	± .76 mm ± .030 in			

GH120², GH781, FC735

-04	1SB4	16.30 mm .640 in	15.37 mm .605 in 15.10 mm ² .595 in ²	**	-M150 -2	3	
-06	1SB6	16.50 mm .650 in	19.69 mm .775 in	**	-M180 -3	3	
-08	1SB8	20.00 mm .790 in	22.99 mm .905 in	**	-M210 -4	3	
-10	1SB10	21.00 mm .830 in	25.78 mm 1.015 in	**	-M240 -4	3	
-12	1SB12	21.60 mm .850 in	30.10 mm 1.185 in	**	-M280 -6	3	
-16	1SB16	25.90 mm 1.020 in	37.47 mm 1.475 in	**	-M370 -8	3	
-20	1SB20	30.70 mm 1.210 in	45.34 mm 1.785 in	**	-M420	3	
-20 ¹	1SB20 Pre-Crimped	30.70 mm 1.210 in	45.34 mm 1.785 in		38.10 mm 1.500 in	4	

FC310, FC510

-03	1SA3	14.00 mm .550 in	12.83 mm .505 in	**	-M120 -90	1	
-04	1SA4	16.30 mm .640 in	15.75 mm .620 in	**	-M150 -2	1	
-05	1SA5	19.30 mm .760 in	17.78 mm .700 in	**	-M180 -93	1	
-06	1SA6	16.50 mm .650 in	20.96 mm .825 in	**	-M210 -3	1	
-08	1SA8	20.00 mm .790 in	23.11 mm .910 in	**	-M210 -4	1	
-10	1SA10	21.00 mm .830 in	26.80 mm 1.055 in	**	-M240 -5	1	
-12	1SA12	21.60 mm .850 in	31.75 mm 1.250 in	**	-M320 -6	1	
-16	1SA16	25.90 mm 1.020 in	37.59 mm 1.480 in	**	-M370 -8	1	
-20	1SA20	30.70 mm 1.210 in	46.74 mm 1.840 in	**	-M465	1	
-20 ¹	1SA20 Pre-Crimped	30.70 mm 1.210 in	46.74 mm 1.840 in		38.10 mm 1.500 in	2	

FC849, FC849B

-06	1SB6	16.50 mm .650 in	20.55 mm .810 in	**	M180 -3	3	
-08	1SB8	20.10 mm .790 in	23.25 mm .915 in	**	M210 -4	3	
-10	1SB10	21.10 mm .830 in	26.65 mm 1.049 in	**	M240 -5	3	
-12	1SB12	21.60 mm .850 in	30.75 mm 1.210 in	**	M280 -6	3	

* Max. crimp ovality .20 mm/.008 in.

** Crimp full length of socket.

1 -20 Global sockets must be pre-crimped to nipple to achieve complete crimp on FT1330 and FT1380 machines.

2 Crimp diameter for GH120-04 only.

Global Skive Crimp Style

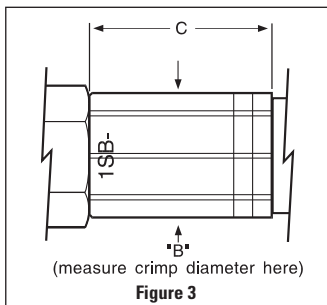
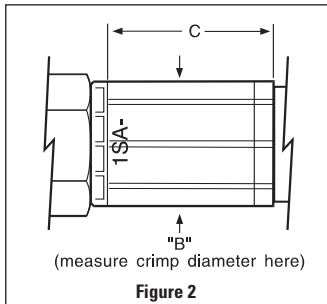
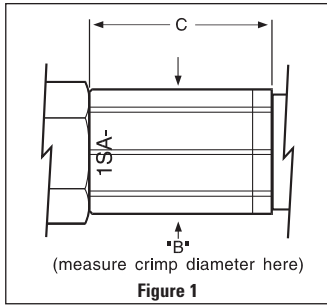
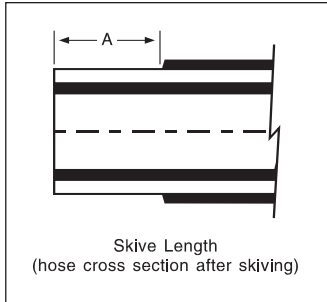

HOSE DASH SIZE	SOCKET PART #	SKIVE LENGTH A	CRIMP DIA. B*	CRIMP LENGTH C	DIE SUFFIX #	SEE FIGURE #	CRIMP MACHINE SETTING
		± .50 mm ± .020 in	± .15 mm ± .006 in	± .76 mm ± .030 in			
FC639, FC839B							
-04	1SA4	16.30 mm .640 in	15.45 mm .610 in	**	M150 -2	1	
-06	1SA6	16.50 mm .650 in	20.85 mm .820 in	**	M210 -3	1	
-08	1SA8	20.10 mm .790 in	23.15 mm .910 in 23.24 mm [†] .915 in [†]	**	M210 -4	1	
-10	1SB10	21.10 mm .830 in	25.75 mm 1.056 in	**	M240 -5	3	
-12	1SB12	21.60 mm .850 in	30.10 mm 1.185 in	**	M280 -6	3	
-16	1SB16	25.90 mm 1.020 in	37.25 mm 1.465 in	**	M370 -8	3	
FC579							
-04	1SB4	16.30 mm .640 in	15.37 mm .605 in	**	M150 -2	3	
-06	1SB6	16.50 mm .650 in	20.55 mm .810 in	**	M210 -3	3	
FC640							
-04	1SB4	16.30 mm .640 in	15.85 mm .625 in	**	M150 -2	3	
-06	1SA6	16.50 mm .650 in	21.35 mm .840 in	**	M210	1	
-08	1SA8	20.00 mm .790 in	23.25 mm .915 in	**	M210	1	
-10	1SA10	21.00 mm .830 in	27.55 mm 1.085 in	**	M280	1	
-12	1SA12	21.60 mm .850 in	31.75 mm 1.250 in	**	M320	1	
-16	1SA16	25.90 mm 1.020 in	37.25 mm 1.465 in	**	M370	1	
GH683							
-4	1SB4	No skive required.	15.85 mm .625 in	**	M150 -2	3	
-6	1SB6	No skive required.	20.55 mm .810 in	**	M210 -3	3	
FC372, FC373, FC727							
-03	1SA3	No skive required.	13.25 mm .520 in	**	M120	1	
-04	1SB4	No skive required.	15.65 mm .618 in	**	M150	3	
-05	1SB5	No skive required.	17.25 mm .680 in	**	M150	3	
-06	1SB6	No skive required.	20.15 mm .795 in	**	M180	3	
-08	1SB8	No skive required.	23.75 mm .935 in	**	M210	3	
-12	1SB12	No skive required.	30.45 mm 1.200 in	**	M280	3	
-16	1SB16	No skive required.	36.05 mm 1.420 in	**	M320 ¹	3	

* Max. crimp ovality .20 mm/.008 in.

** Crimp full length of socket.

† Crimp diameter for FC839B-8 only.

¹ FT1380-200-M320 not approved

Global Nipple with Low Pressure Hose

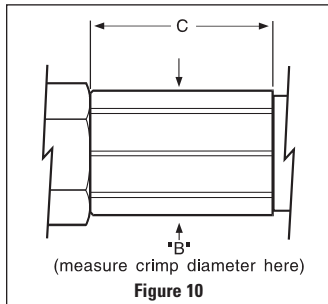
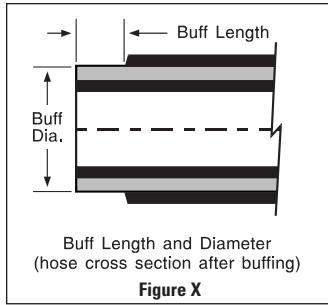
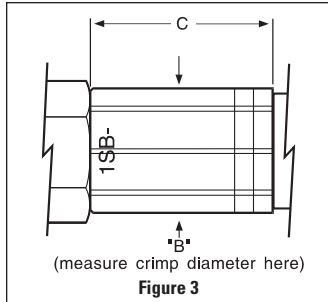

HOSE DASH SIZE	SOCKET PART #	CRIMP DIA. B*	CRIMP LENGTH C	DIE SUFFIX #	SEE FIGURE #	CRIMP MACHINE SETTING
		± .15 mm ± .006 in	minimum			
FC466						
-04	1SB4	15.62 mm .615 in	**	-M150 -2	3	
-06	1SB6	20.20 mm .795 in	**	-M180 -3	3	
-08	1SB8	23.12 mm .910 in	**	-M210 -4	3	
-10	1SB10	25.78 mm 1.015 in	**	-M240 -4	3	
-12	1SB12	30.36 mm 1.195 in	**	-M280 -6	3	
FC498, FC598						
-04	1SB4	15.62 mm .615 in	**	-M150 -2	3	
-06	1SB6	20.45 mm .805 in	**	-M180 -3	3	
-08	1SB8	23.12 mm .910 in	**	-M210 -4	3	
-10	1SB10	26.77 mm 1.054 in	**	-M240 -4	3	
-12	1SB12	30.36 mm 1.195 in	**	-M280 -6	3	

HOSE DASH SIZE	SOCKET PART #	MIN. BUFF DIA. ¹	BUFF LENGTH	CRIMP DIA. B	CRIMP LENGTH C	DIE SUFFIX #	FIG. #	CRIMP MACHINE SETTING
			± .76 mm ± .030 in	± .15 mm ± .006 in	± .76 mm ± .030 in			
2661, FC318								
-40	FC3023	78.2 mm	64.8 mm	78.26 mm	**	-18 ²	10	
		3.08 in	2.55 in	3.081 in				

* Max. crimp ovality .20 mm / .008 in.

** Crimp full length of socket.

1 Buffing may be required to obtain socket assembly. Do not exceed the minimum buff diameter.

2 For FT1049 machine only.

Global TTC and TTC12 Crimp Style

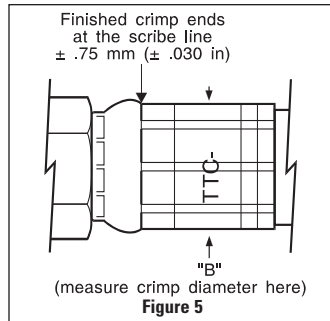

* Max. crimp ovality .20 mm/.008 in.

1 FT1209-200-23 not approved.

2 FT1330-200-9 not approved.

3 FT1049-100-M465 only.

HOSE DASH SIZE	SOCKET PART #	CRIMP DIA. B*	DIE SUFFIX #	SEE FIGURE #	CRIMP MACHINE SETTING
		± .15 mm ± .006 in			
GH194					
-04	TTC-4	15.75 mm .620 in	-M150 -2	5	
-06	TTC-6	19.56 mm .770 in	-M180 -3	5	
-08	TTC-8	23.88 mm .940 in	-M240 -4	5	
-10	TTC-10	26.80 mm 1.055 in	-M240 -5	5	
-12	TTC-12	31.75 mm 1.250 in	-M320 -6	5	
-16	TTC-16	40.39 mm 1.590 in	-M370 -8	5	
-20	TTC-20 (1-Ring)	45.72 mm 1.800 in	-M420	5	
GH195					
-04	TTC-4	16.89 mm .665 in	-M150 -2	5	
-06	TTC-6	21.21 mm .835 in	-M210 -3	5	
-08	TTC-8	25.15 mm .990 in	-M240 -4	5	
-10	TTC-10	28.70 mm 1.130 in	-M280 -5	5	
-12	TTC-12	32.51 mm 1.280 in	-M320 -6	5	
-16	TTC-16	41.66 mm 1.640 in	-M370 -8	5	
-20	TTC-20 (2 Rings)	50.80 mm 2.000 in	-M465 -9 ²	5	
-24	TTC-24	57.66 mm 2.270 in	-M550 -11	5	
-32	TTC-32	70.36 mm 2.770 in	-M690 -23 ¹ -17	5	
FC613, GH663, FC211					
-04	TTC-4	15.75 mm .620 in	-M150 -2	5	
-06	TTC-6	19.94 mm .785 in	-M180 -3	5	
-08	TTC-8	23.88 mm .940 in	-M240 -4	5	
-10	TTC-10	26.80 mm 1.055 in	-M240 -5	5	
-12	TTC-12	31.75 mm 1.250 in	-M320 -6	5	
-16	TTC-16	40.39 mm 1.590 in	-M370 -8	5	
-20	TTC-20 (1 Ring)	46.00 mm 1.811 in	-M420 -M465 ³	5	
-24	TTC-24	55.40 mm 2.181 in	-M550	5	
-32	TTC-32	68.61 mm 2.701 in	-M690	5	

Global TTC and TTC12 Crimp Style

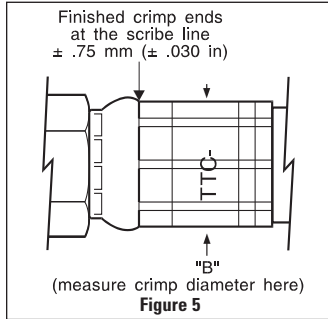

* Max. crimp ovality .20 mm/.008 in.

- 1 FT1209-200-23 not approved.
- 2 FT1330-200-9 not approved.
- 3 FT1049-100-M465 only.

HOSE DASH SIZE	SOCKET PART #	CRIMP DIA. B*	DIE SUFFIX #	SEE FIGURE #	CRIMP MACHINE SETTING
		± .15 mm ± .006 in			
FC611					
-04	TTC-4	16.00 mm .630 in	-M150 -2	5	
-06	TTC-6	19.69 mm .775 in	-M180 -3	5	
-08	TTC-8	23.62 mm .930 in	-M240 -4	5	
-12	TTC-12	31.62 mm 1.245 in	-M320 -6	5	
-16	TTC-16	40.26 mm 1.585 in	-M370 -8	5	
-20	TTC-20 (1 Ring)	47.50 mm 1.870 in	-M465 -9 ²	5	
-24	TTC-24	54.74 mm 2.155 in	-M550	5	
-32	TTC-32	68.58 mm 2.700 in	-M690	5	
GH793, FC212					
-04	TTC-4	17.27 mm .680 in	-M150 -2	5	
-06	TTC-6	21.21 mm .835 in	-M210 -3	5	
-08	TTC-8	25.15 mm .990 in	-M240 -4	5	
-10	TTC-10	28.70 mm 1.130 in	-M280 -5	5	
-12	TTC-12	32.51 mm 1.280 in	-M320 -6	5	
-16	TTC-16	41.40 mm 1.630 in	-M370 -8	5	
-20	TTC-20 (2 Rings)	49.78 mm 1.960 in	-M465 -9 ²	5	
-24	TTC-24	57.66 mm 2.270 in	-M550 -11	5	
-32	TTC-32	70.87 mm 2.790 in	-M690 -17 -23 ¹	5	
GH120					
-04	TTC-4	16.26 mm .640 in	-M150 -2	5	
-06	TTC-6	20.32 mm .800 in	-M210 -3	5	
-08	TTC-8	24.77 mm .975 in	-M240 -4	5	
-10	TTC-10	28.32 mm 1.115 in	-M280 -5	5	
-12	TTC-12	31.62 mm 1.245 in	-M320 -6	5	
-16	TTC-16	39.75 mm 1.565 in	-M370 -8	5	
-20	TTC-20 (2 Rings)	48.26 mm 1.900 in	-M465 -9 ²	5	
-24	TTC-24	54.75 mm 2.155 in	-M550	5	
-32	TTC-32	68.55 mm 2.700 in	-M690	5	

Global TTC and TTC12 Crimp Style

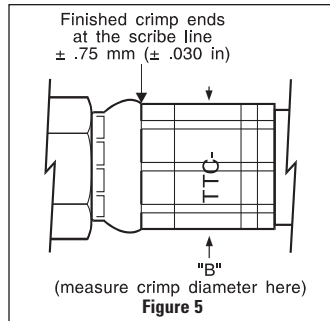

- * Max. crimp ovality .20 mm/.008 in.
- 1 FT1330-200-9 not approved.
- 2 For FT1049 and FT1330 crimp machines only.

HOSE DASH SIZE	SOCKET PART #	CRIMP DIA. B*	DIE SUFFIX #	SEE FIGURE #	CRIMP MACHINE SETTING
		± .15 mm ± .006 in			
GH683					
-04	TTC-4	15.37 mm .605 in	-M150 -2	5	
-06	TTC-6	19.94 mm .785 in	-M180 -3	5	
-08	TTC-8	23.88 mm .940 in	-M240 -4	5	
GH781, FC735					
-04	TTC-4	16.89 mm .665 in	-M150 -2	5	
-06	TTC-6	20.70 mm .815 in	-M210 -3	5	
-08	TTC-8	24.77 mm .975 in	-M240 -4	5	
-10	TTC-10	28.32 mm 1.115 in	-M280 -5	5	
-12	TTC-12	31.62 mm 1.245 in	-M320 -6	5	
-16	TTC-16	39.75 mm 1.565 in	-M370 -8	5	
-20	TTC-20 (2 Rings)	48.26 mm 1.900 in	-M465 -9 ¹	5	
-24	TTC-24	54.75 mm 2.155 in	-M550	5	
-32	TTC-32	68.55 mm 2.700 in	-M690	5	
FC310					
-04	TTC-4	16.26 mm .640 in	-M150 -2	5	
-06	TTC-6	20.19 mm .795 in	-M180 -3	5	
-08	TTC-8	23.62 mm .930 in	-M240 -4	5	
-10	TTC-10	26.80 mm 1.055 in	-M240 -5	5	
-12	TTC-12	31.75 mm 1.250 in	-M320 -6	5	
-16	TTC-16	40.13 mm 1.580 in	-M370 -8	5	
-20	TTC-20 (1 Ring)	45.21 mm 1.780 in	-M420 -8 ²	5	
FC510					
-04	TTC-4	16.51 mm .650 in	-M150 -2	5	
-06	TTC-6	20.70 mm .815 in	-M210 -3	5	
-08	TTC-8	23.24 mm .915 in	-M210 -4	5	
-10	TTC-10	26.80 mm 1.055 in	-M240 -5	5	
-12	TTC-12	31.75 mm 1.250 in	-M320 -6	5	
-16	TTC-16	40.13 mm 1.580 in	-M370 -8	5	
-20	TTC-20 (1 Ring)	45.21 mm 1.780 in	-M420 -8 ²	5	

Global TTC and TTC12 Crimp Style

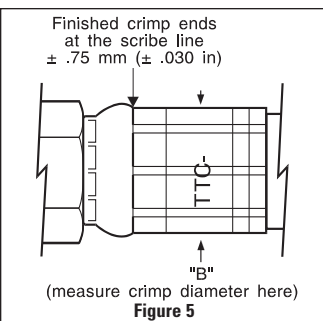

* Max. crimp ovality .20 mm/.008 in.

HOSE DASH SIZE	SOCKET PART #	CRIMP DIA. B*	DIE SUFFIX #	SEE FIGURE #	CRIMP MACHINE SETTING
		± .15 mm ± .006 in			
GH681					
-06	TTC-6	19.68 mm .775 in	-M180 -3	5	
FC849, FC849B					
-04	TTC-4	17.25 mm .680 in	M150 -2	5	
-06	TTC-6	21.25 mm .835 in	M210 -3	5	
-08	TTC-8	25.15 mm .990 in	M240 -4	5	
-10	TTC-10	28.65 mm 1.129 in	M280 -5	5	
-12	TTC-12	32.65 mm 1.286 in	M320	5	
FC579					
-04	TTC-4	16.89 mm .665 in	M150 -2	5	
-06	TTC-6	21.25 mm .835 in	M210 -3	5	
FC640					
-04	TTC-4	17.25 mm .680 in	M150	5	
-06	TTC-6	20.05 mm .790 in	M180	5	
-08	TTC-8	23.45 mm .925 in	M240	5	
-10	TTC-10	27.45 mm 1.080 in	M240	5	
-12	TTC-12	31.65 mm 1.245 in	M320	5	
-16	TTC-16	38.95 mm 1.535 in	M370	5	
FC639, FC839B					
-04	TTC-4	15.85 mm .625 in	M150	5	
-06	TTC-6	19.65 mm .775 in	M180	5	
-08	TTC-8	23.45 mm .925 in	M210	5	
-10	TTC-10	28.35 mm 1.115 in	M280	5	
-12	TTC-12	32.35 mm 1.275 in	M320	5	
-16	TTC-16	39.58 mm 1.575 in	M370	5	
FC616					
-06	TTC-6	22.75 mm .896 in	M210 -4	5	

Global TTC and TTC12 Crimp Style

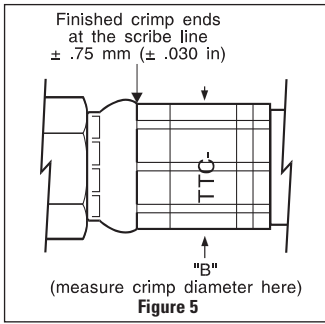

Figure 5

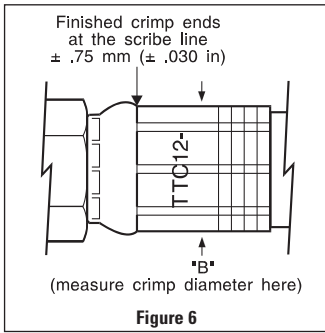
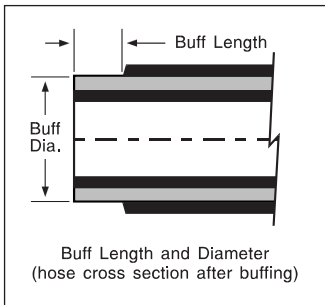

Figure 6



Buff Length and Diameter (hose cross section after buffing)

* Max. crimp ovality .20 mm/.008 in.

** Max. crimp ovality .30 mm/.012 in.

1 Approved at SAE 100R12 pressures only.

2 FT1330-275-M370, FT1330-200-8 and FT1049-100-8 also approved.

3 FT1380-200-M465, FT1330-275-M465 and FT1049-100-9 also approved.

4 FT1209-200-23 not approved.

5 Buffing may be required to obtain socket assembly only. Do not exceed the minimum buff diameter.

6 FT1380-200-M465, FT1330-275-M465 also approved.

7 FT1330-200-9 not approved.

8 Use FT1209-200-17 or FT1049-100-17.

9 FT1330-200-6, FT1049-100-8, and FT1307-200-8 also approved.

HOSE DASH SIZE	SOCKET PART #	CRIMP DIA. B*	DIE SUFFIX #	SEE FIGURE #	CRIMP MACHINE SETTING
		± .15 mm ± .006 in			
GH493, FC136¹, FC659, FC736, FC805					
-06	TTC12-6	22.76 mm .896 in	-M210 -4	6	
-08	TTC12-8	27.81 mm 1.095 in	-M280 -5	6	
-10	TTC12-10	30.48 mm 1.200 in	-M280 -6	6	
-12	TTC12-12	34.42 mm 1.355 in	-M320 -6	6	
-16	TTC12-16	43.82 mm** 1.725 in	-M420 ²	6	
-20	TTC12-20	52.20 mm** 2.055 in	-M520 ³	6	
-24	TTC12-24	55.88 mm** 2.200 in	-M550 -11	6	
-32	TTC12-32	69.16 mm** 2.723 in	-M690 -23 ⁴	6	
FC636					
-12	TTC12-12	34.29 mm 1.350 in	-M320 -6	6	
-16	TTC12-16	43.69 mm 1.720 in	-M420 ²	6	
-20	TTC12-20	52.58 mm 2.070 in	-M520 ³	6	
-24	TTC12-24	56.13 mm 2.210 in	-M550 -11	6	
FC693					
-04	TTC-04	17.40 mm .685 in	-M150 -2	5	
-06	TTC-06	21.21 mm .835 in	-M210 -3	5	
-08	TTC-08	25.40 mm 1.000 in	-M240 -4	5	

HOSE DASH SIZE	SOCKET PART #	MIN. BUFF DIA. ⁵	BUFF LENGTH	CRIMP DIA. B	DIE SUFFIX #	SEE FIGURE #	CRIMP MACHINE SETTING
			± .76 mm ± .030 in	± .15 mm ± .006 in			
2661, FC318							
-12	TTC-12	30 mm 1.18 in	19 mm .75 in	35.59 mm 1.401 in	-M320 -6	5	
-12	TTC12-12	N/A	N/A	35.99 mm 1.417 in	-M320 -6	6	
-16	TTC-16	N/A	N/A	43.38 mm 1.708 in	-M420 -8	5	
-20	TTC-20 (2 Rings)	N/A	N/A	51.79 mm 2.039 in	-M520 ⁶ -9 ⁷	5	
-24	TTC-24	N/A	N/A	58.19 mm 2.291 in	-M570 -11	5	
-32	TTC-32	N/A	N/A	70.31 mm 2.768 in	-M690 -17 ⁸ -23 ⁴	5	
FC619							
-12	TTC-12	30mm 1.18 in	19mm .75 in	33.55 mm 1.320 in	-M320 -6	5	
-16	TTC-16	N/A	N/A	41.40 mm 1.630 in	-M370 ⁹	5	
-20	TTC-20 (2 Rings)	N/A	N/A	49.95 mm 1.970 in	-M465 -9 ⁷	5	
-24	TTC-24	N/A	N/A	56.35 mm 2.220 in	-M550 -11	5	
-32	TTC-32	N/A	N/A	70.15 mm 2.760 in	-M690 -17 ⁸ -23 ⁴	5	

Global OTC Crimp Style

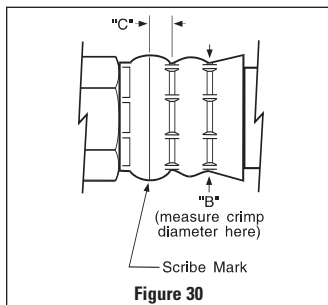
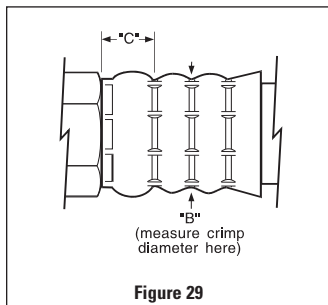
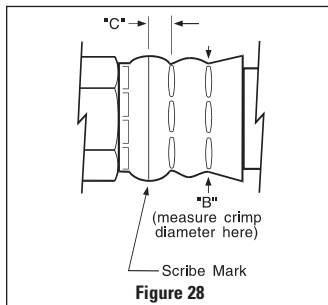
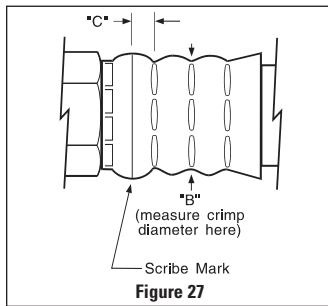
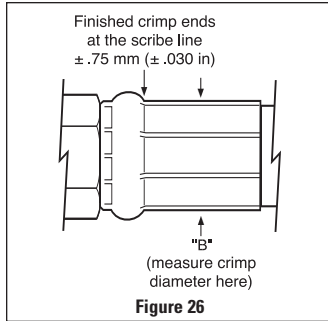

HOSE DASH SIZE	SOCKET PART #	CRIMP DIA. B*	CRIMP LENGTH C	DIE SUFFIX #	SEE FIGURE #	CRIMP MACHINE SETTING
		± .15 mm ± .006 in	± .76 mm ± .030 in			
2583						
-4	1G4	14.00 mm .551 in	**	-M120 -1	26	
-6	1G6	20.00 mm .787 in	**	-M180 -3	26	
-8	1G8	23.30 mm .917 in	**	-M210 -4	26	
-12	1G12	31.60 mm 1.244 in	**	-M320 -6	26	
-16	1G16	37.40 mm 1.472 in	**	-M370 -8	26	
-20	1G20	42.50 mm 1.673 in	**	-M420	26	
2661, FC318						
-12	1G12	29.65 mm 1.167 in	5.0 mm .197 in	-51 ² -54 ¹	28	
		29.72 mm 1.170 in	5.8 mm .228 in	-184	30	
-16	1G16	35.35 mm 1.392 in	8.0 mm .315 in	-51	28	
		36.45 mm 1.435 in	7.6 mm .299 in	-185	30	
-20	1G20	43.85 mm 1.726 in	5.0 mm .197 in	-86	27	
		43.31 mm 1.705 in	9.6 mm .378 in	-186	30	
-24	1G24	51.70 mm 2.035 in	19.1 mm .752 in	-31	29	
-32	1G32	62.30 mm 2.453 in	17.0 mm .669 in	-32	29	
FC619						
-12	1G12	31.45 mm 1.240 in	**	-M320 -6	26	
-16	1G16	36.85 mm 1.450 in	**	-M370 -8	26	
-20	1G20	44.45 mm 1.750 in	**	-M420	26	
-24	1G24	51.05 mm 2.010 in	**	-M520	26	
-32	1G32	64.52 mm 2.540 in 2.540 in	**	-M630 23 ⁴ 17 ³	26	
FC466						
-4	1G4	12.70 mm .500 in	**	-M120 -1 -90	26	
-6	1G6	17.80 mm .701 in	**	-M180 -2	26	
-8	1G8	20.60 mm .811 in	**	-M210 -3	26	
-12	1G12	27.70 mm 1.091 in	**	-M280 -5	26	

* Max. crimp ovality .20 mm/.008 in.

** Finished crimp ends at the scribe mark ±.75 mm (±.030 in.)

1 FT1307 die cage only.

2 FT1204-100-51 and FT1307-200-51 not approved.

3 Use FT1209-200-17 or FT1049-100-17.

4 FT1209-200-23 not approved.

Global OTC Crimp Style

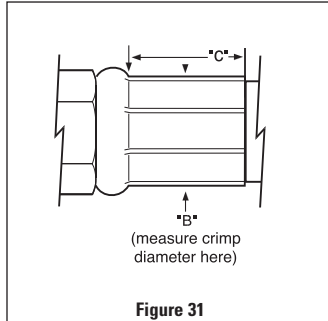
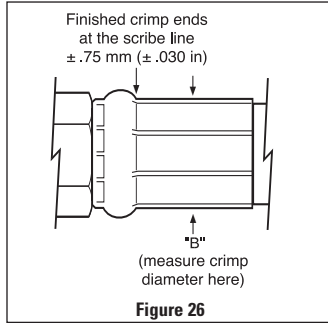

* Max. crimp ovality .20 mm/.008 in.

** Finished crimp ends at the scribe mark ±.75 mm (±.030 in.)

HOSE DASH SIZE	SOCKET PART #	CRIMP DIA. B*	CRIMP LENGTH C	DIE SUFFIX #	SEE FIGURE #	CRIMP MACHINE SETTING
		± .15 mm ± .006 in	± .76 mm ± .030 in			
FC498, FC598						
-4	1G4	13.00 mm .512 in	**	-M120 -1	26	
-6	1G6	17.80 mm .701 in	**	-M180 -2	26	
-8	1G8	21.40 mm .843 in	**	-M210 -3	26	
-10	1G10	24.51 mm .965 in	**	-M240	26	
-12	1G12	28.50 mm 1.122 in	**	-M280 -5	26	
FC363, FC364						
-10	1G10	21.75 mm .857 in	**	M210	26	
-12	1G12	26.55 mm 1.045 in	**	M240	26	
-16	1G16	32.75 mm 1.291 in	**	M320	26	
-20	1G20	39.15 mm 1.543 in	**	M370	26	
-24	1G24	44.95 mm 1.771 in	**	M420	26	
FC699						
-04	1G4	12.85 mm .507 in	**	M120	26	
-06	1G6	17.85 mm .701 in	**	M180	26	
-08	1G8	20.60 mm .811 in	**	M210	26	
-10	1G10	24.35 mm .957 in	**	M240	26	
-12	1G12	28.55 mm 1.124 in	**	M280	26	
-16	1G16	34.75 mm 1.367 in	**	M320	26	
FC699 w/ FW1097						
-04	FW1097	13.15 mm .517 in	13.5 ±.4 (.575±.015)	M120	31	
-06	FW1097	15.55 mm .613 in	14.6 ±.4 (.575±.015)	M150	31	
-08	FW1097	18.65 mm .733 in	14.6 ±.4 (.575±.015)	M180	31	
-10	FW1097	22.55 mm .889 in	17.4 ±.4 (.685±.015)	M210	31	
-12	FW1097	25.75 mm 1.015 in	17.4 ±.4 (.685±.015)	M240	31	

Barrel Field Crimp Style

Use of the Aeroquip Calidapter (part no. FT1297) is recommended for measurement of barrel field crimp diameters. See accessories on page 37.

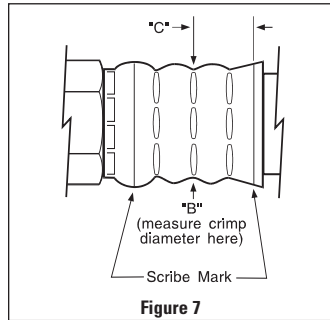

* Max. crimp ovality .30 mm/.012 in.

- 1 FT1008 dies only.
- 2 FT1049-100-SIZE, FT1204-100-SIZE and FT1307-200-SIZE only.
- 3 FT1204-100-51 and FT1307-200-51 not approved.
- 4 FT1204-100-52 and FT1307-200-52 not approved.
- 5 Approved at SAE 100R1 pressures only.
- 6 Approved at SAE 100R2 pressures only.

HOSE DASH SIZE	SOCKET PART #	CRIMP DIA. B*	CRIMP LENGTH C	DIE SUFFIX #	SEE FIGURE #	CRIMP MACHINE SETTING
		± .18 mm ± .007 in	± .76 mm ± .030 in			
2583, 2661, FC318						
-04	FC1130	13.21 mm .520 in	19.05 mm .750 in	-5 ¹ -52	7	
-06	FC1130	18.54 mm .730 in	19.05 mm .750 in	-5 ¹ -52	7	
-08	FC1130	22.00 mm .865 in	19.05 mm .750 in	-5 ¹ -52 ² -53 ³	7	
-12	FC1130	31.12 mm 1.225 in	19.05 mm .750 in	-4 ¹ -51 ³ -54 ²	7	
-16	FC1130	37.21 mm 1.465 in	19.05 mm .750 in	-4 ¹ -51	7	
-20	FC1130	43.81 mm 1.725 in	19.05 mm .750 in	-86 -88	7	
GH663⁵, FC211						
-04	FC1130	12.45 mm .490 in	19.05 mm .750 in	-5 ¹ -52	7	
-06	FC1130	16.90 mm .665 in	19.05 mm .750 in	-5 ¹ -52	7	
-08	FC1130	19.56 mm .770 in	19.05 mm .750 in	-5 ¹ -52 ² -53 ³	7	
-12	FC1130	27.80 mm 1.090 in	19.05 mm .750 in	-4 ¹ -51 ³ -54 ²	7	
-16	FC1130	35.94 mm 1.415 in	19.05 mm .750 in	-4 ¹ -51	7	
GH793⁶, FC212						
-04	FC1130	13.84 mm .545 in	19.05 mm .750 in	-5 ¹ -52	7	
-06	FC1130	17.02 mm .700 in	19.05 mm .750 in	-5 ¹ -52	7	
-08	FC1130	20.57 mm .810 in	19.05 mm .750 in	-5 ¹ -52 ² -53 ³	7	
-10	FC1130	22.99 mm .905 in	19.05 mm .750 in	-52 -53 ³	7	
-12	FC1130	28.70 mm 1.130 in	19.05 mm .750 in	-4 ¹ -51 ³ -54 ²	7	
-16	FC1130	36.45 mm 1.435 in	19.05 mm .750 in	-4 ¹ -51	7	
-20	FC1130	46.10 mm 1.815 in	19.05 mm .750 in	-86 -88	7	

Barrel Field Crimp Style

Use of the Aeroquip Calidapter (part no. FT1297) is recommended for measurement of barrel field crimp diameters. See accessories on page 37.

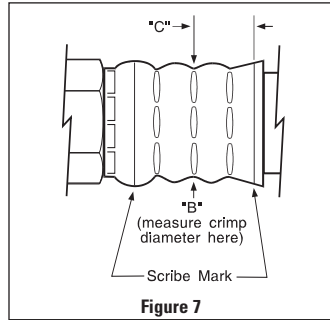

Figure 7

* Max. crimp ovality .30 mm/.012 in.

1 FT1008 dies only.

2 FT1049-100-SIZE, FT1204-100-SIZE and FT1307-200-SIZE only.

3 Qualified only for maximum +200°F hydraulic service with barrel field crimp fittings.

HOSE DASH SIZE	SOCKET PART #	CRIMP DIA. B*	CRIMP LENGTH C	DIE SUFFIX #	SEE FIGURE #	CRIMP MACHINE SETTING
		± .18 mm ± .007 in	± .76 mm ± .030 in			
FC310						
-04	FC1130	12.32 mm .485 in	19.05 mm .750 in	-51 -52	7	
-06	FC1130	16.13 mm .635 in	19.05 mm .750 in	-51 -52	7	
-08	FC1130	19.18 mm .755 in	19.05 mm .750 in	-51 -52 -53 ²	7	
-10	FC1130	21.13 mm .832 in	19.05 mm .750 in	-51 -52 -53 ²	7	
-12	FC1130	27.31 mm 1.075 in	19.05 mm .750 in	-4 ¹ -51 -54 ²	7	
-16	FC1130	33.40 mm 1.315 in	19.05 mm .750 in	-41 -51	7	
-20	FC1130	40.08 mm 1.578 in	19.05 mm .750 in	-86	7	
FC510³ (Note: Qualified only for maximum +200°F hydraulic service)						
-04	FC1130	12.07 mm .475 in	19.05 mm .750 in	-5 ¹ -52	7	
-06	FC1130	16.21 mm .638 in	19.05 mm .750 in	-5 ¹ -52	7	
-08	FC1130	19.10 mm .752 in	19.05 mm .750 in	-5 ¹ -52 -53 ²	7	
-10	FC1130	21.01 mm .827 in	19.05 mm .750 in	-5 ¹ -52 -53 ²	7	
-12	FC1130	26.64 mm 1.049 in	19.05 mm .750 in	-4 ¹ -54 ²	7	
-16	FC1130	32.13 mm 1.265 in	19.05 mm .750 in	-4 ¹ -51 -54 ²	7	

Flat Field Crimp Style

Use of the Aeroquip Calidapter (part no. FT1297) is recommended for measurement of barrel field crimp diameters. See accessories on page 37.

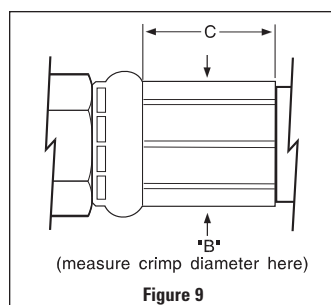
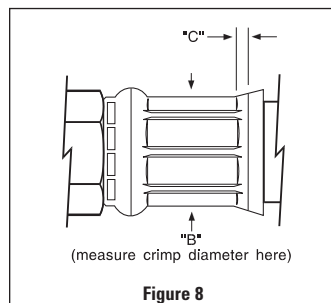

* Max. crimp ovality .30 mm/.012 in.

- 1 Use FT1204-100-0016 or FT1307-200-0016.
- 2 Use FT1208-100-1620 or FT1330-200-1620.
- 3 Use with FT1204-100-11 or FT1307-200-11.
- 4 Use FT1209-200-16 or FT1049-100-16.
- 5 Use FT1209-200-17 or FT1049-100-17.
- 6 Approved at SAE 100R1 pressures only.
- 7 Approved at SAE 100R2 pressures only.

HOSE DASH SIZE	SOCKET PART #	CRIMP DIA. B*	CRIMP LENGTH C	DIE SUFFIX #	SEE FIGURE #	CRIMP MACHINE SETTING
		± .18 mm ± .007 in	± .51 mm ± .020 in			
GH663⁶, FC211						
-04	FC1130	14.55 mm .573 in	5.08 mm .200 in	-0004	8	
-06	FC1130	19.23 mm .757 in	5.08 mm .200 in	-0608	8	
-08	FC1130	22.10 mm .870 in	5.08 mm .200 in	-0608	8	
-12	FC1130	28.50 mm 1.122 in	5.08 mm .200 in	-1012	8	
-16	FC1130	36.98 mm 1.456 in	5.08 mm .200 in	-0016 ¹ -1620 ²	8	
GH793³, FC212						
-04	FC1130	16.00 mm .630 in	5.08 mm .200 in	-0004	8	
-06	FC1130	20.07 mm .790 in	5.08 mm .200 in	-0608	8	
-08	FC1130	24.00 mm .945 in	5.08 mm .200 in	-0608	8	
-12	FC1130	31.06 mm 1.223 in	5.08 mm .200 in	-1012	8	
-16	FC1130	38.48 mm 1.515 in	5.08 mm .200 in	-0016 ¹ -1620 ²	8	
-24	FC1130	60.27 mm 2.373 in	46.23 mm 1.820 in	-11 ³ -16 ⁴ -M550	9	
-32	FC1130	73.96 mm 2.912 in	58.67 mm 2.310 in	-17 ⁵ -M690	9	
FC310						
-04	FC1130	15.29 mm .602 in	5.08 mm .200 in	-0004	8	
-06	FC1130	18.54 mm .730 in	5.08 mm .200 in	-0608	8	
-08	FC1130	22.17 mm .873 in	5.08 mm .200 in	-0608	8	
-10	FC1130	25.50 mm 1.004 in	5.08 mm .200 in	-1012	8	
-12	FC1130	28.70 mm 1.130 in	5.08 mm .200 in	-1012	8	
-16	FC1130	36.32 mm 1.430 in	5.08 mm .200 in	-0016 ¹ -1620 ²	8	
2661, FC318						
-12	FC1130	32.26 mm 1.270 in	5.08 mm .200 in	-1012	8	
-16	FC1130	38.20 mm 1.504 in	5.08* mm .200 in	-0016 ¹ -1620 ²	8	

Flat Crimp Style

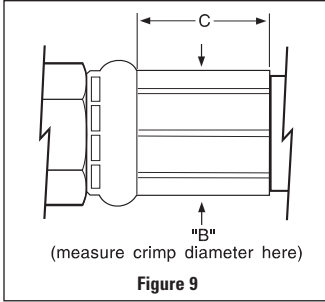

Figure 9

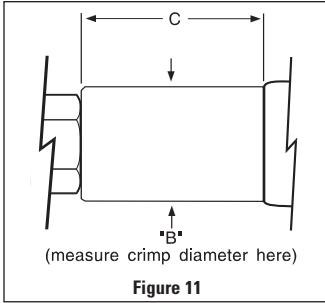

Figure 11

* Max. crimp ovality .20 mm/.008 in.

** Crimp full length of collar.

HOSE DASH SIZE	SOCKET PART #	CRIMP DIA. B*	CRIMP LENGTH C	DIE SUFFIX #	SEE FIGURE #	CRIMP MACHINE SETTING
		± .12 mm ± .005 in	± .38 mm ± .015 in			

FC372, FC373, FC390, FC690, FC727

-02	FC1006	9.52 mm .375 in	11.94 mm .470 in	-M090	9	
-03	FC1006	12.75 mm .502 in	19.94 mm .785 in	-M120 -90	9	
-04	FC1006	14.47 mm .570 in	22.48 mm .885 in	-M120 -91	9	
-05	FC1006	16.26 mm .640 in	27.94 mm 1.100 in	-M150 -92	9	
-06	FC1006	17.90 mm .705 in	32.39 mm 1.275 in	-M180 -93	9	
-08	FC1006	21.71 mm .855 in	37.47 mm 1.475 in	-M210 -94	9	
-10	FC1006	24.58 mm .968 in	38.10 mm 1.500 in	-M240 -94	9	
-12	FC1006	28.19 mm 1.110 in	38.10 mm 1.500 in	-M280 -95	9	
-16	FC1006	33.78 mm 1.330 in	51.44 mm 2.025 in	-M320 -100	9	

FC374, FC375

-03	FC1006	12.75 mm .502 in	19.94 mm .785 in	-M120 -90	9	
-04	FC1006	14.22 mm .560 in	22.48 mm .885 in	-M120 -91	9	
-06	FC1006	17.65 mm .695 in	32.39 mm 1.275 in	-M180 -93	9	
-08	FC1006	21.46 mm .845 in	37.47 mm 1.475 in	-M210 -94	9	
-12	FC1006	27.68 mm 1.090 in	38.10 mm 1.500 in	-M280 -95	9	
-16	FC1006	33.78 mm 1.330 in	51.44 mm 2.025 in	-M320 -100	9	

FC376, FC377

-03	FC1579	13.97 mm .550 in	21.59 mm .850 in	-M120 -91	9	
-04	FC1579	15.75 mm .620 in	27.94 mm 1.100 in	-M150 -92	9	
-06	FC1579	19.73 mm .777 in	30.48 mm 1.200 in	-M180 -147	9	

HOSE DASH SIZE	COLLAR PART #	COLLAR LENGTH	CRIMP DIA. B*	CRIMP LENGTH C	DIE SUFFIX #	SEE FIG. #	CRIMP MACHINE SETTING
			± .12 mm ± .005 in				

FC376, FC377 (protective guard collars)

-03	FF9843	21.84 mm .860 in	24.13 mm .950 in	**	-M240 -4	11	
-04	FF9843	23.62 mm .930 in	26.67 mm 1.050 in	**	-M240 -5	11	
-06	FF9843	25.40 mm 1.000 in	30.35 mm 1.195 in	**	-M280 -6	11	

Flat Crimp Style

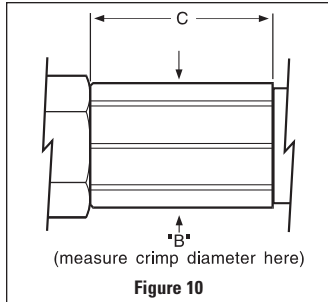

Figure 10

NOTE: A positive backstop for fitting location is required for all hose sizes.

* Max. crimp ovality .08 mm/.006 in.

** Crimp full length of socket.

1 FC563 requires the removal of the polyester overbraid w/a thermal stripping tool (Aeroquip part number S1364) prior to crimping. Contact your customer service representative for more details.

2 The -M570 die cage spring plate cut-outs must be lengthened an additional 0.80mm (1/32") to allow the dies to retract sufficiently to accommodate -32 size fittings.

HOSE DASH SIZE	SOCKET PART #	CRIMP DIA. B*	CRIMP LENGTH C	DIE SUFFIX #	SEE FIGURE #	CRIMP MACHINE SETTING
		± .08 mm ± .003 in				
2807, FC186, FC465						
-03	FC3596	6.99 mm .275 in	**	-M070 -39	10	
-04	FC3596	8.56 mm .337 in	**	-M090 -39	10	
-05	FC3443-04	10.34 mm .407 in	**	-M090 -40	10	
-06	FC3443-05	11.86 mm .467 in	**	-M120 -41	10	
-08	FC3596	14.40 mm .567 in	**	-M150 -36	10	
-10	FC3443-08	16.94 mm .667 in	**	-M150 -37	10	
-12	FC3596	19.99 mm .787 in	**	-M180 -37	10	
-16	FC3596	27.25 mm 1.073 in	**	-M240 -5	10	

HOSE DASH SIZE	SOCKET PART #	SKIVE LENGTH A	CRIMP DIA. B*	CRIMP LENGTH C	DIA. SUFFIX #	SEE FIGURE #	CRIMP MACHINE SETTING
		± .51 mm ± .020 in	± .08 mm ± .003 in				
FC363, FC364, FC563¹							
-06	FC1347	29.97 mm 1.180 in	16.64 mm .655 in	**	-M150 -92	10	
-08	FC1347	29.97 mm 1.180 in	21.46 mm .845 in	**	-M210 -94	10	
-12	FC1347	29.97 mm 1.180 in	27.91 mm 1.099 in	**	-M280 -109	10	
-16	FC1347	29.97 mm 1.180 in	33.96 mm 1.337 in	**	-M320 -110	10	
-20	FC1347	29.97 mm 1.180 in	40.56 mm 1.597 in	**	-M370 -101	10	
-24	FC1347	35.56 mm 1.400 in	46.23 mm 1.820 in	**	-M465 -102	10	
-32	FC1347	35.56 mm 1.400 in	58.34 mm 2.297 in	**	-M570 ² -103	10	

HOSE DASH SIZE	SOCKET PART #	SKIVE LENGTH A	CRIMP DIA. B*	CRIMP LENGTH C	DIA. SUFFIX #	SEE FIGURE #	CRIMP MACHINE SETTING
		± .51 mm ± .020 in	± .12 mm ± .005 in				
FC807							
-03	FC3596	7.00 mm .278 in	15.20 mm .600 in	**	M070 -39	10	
-04	FC3596	8.56 mm .337 in	16.50 mm .650 in	**	M090 -39	10	
-05	FC3443	10.34 mm .407 in	16.50mm .650 in	**	M090 -40	10	
-06	FC3443	11.86 mm .467 in	16.50 mm .650 in	**	M120 -41	10	
-08	FC3596	14.40 mm .567 in	23.90 mm .940 in	**	M150 -36	10	
-10	FC3443	16.94 mm .667 in	23.90 mm .940 in	**	M150 -37	10	
-12	FC3596	19.99 mm .787 in	23.90 mm .940 in	**	M180 -37	10	
-16	FC3596	27.25 mm 1.073 in	24.60 mm .970 in	**	M240 -5	10	
FC807 Brass Only							
-12	FW1386	20.80 mm .819 in	20.78 mm .818 in	**	M180 -37	10	

Global Spiral TTC Crimp Style

Note: To achieve full flat crimp, locate back edge of socket approximately 3 mm (1/8") from back edge of crimp jaws.

On 1EA12FJ12 and 1EA12FR12 fittings, a 19.05 mm (3/4") to 31.75 mm (1-1/4") crimp locating rule should be used. Use the standard 3 mm (1/8") guideline for all other Spiral TTC fittings.

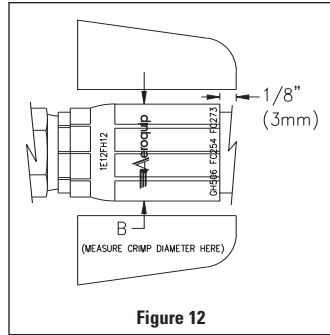

Figure 12

To achieve full flat crimp back edge of socket approximately 3mm (1/8") from the back edge of the crimp jaws as shown in Figure 12.

* Max. crimp ovality .30 mm/.012 in.

HOSE DASH SIZE	SOCKET PART #	CRIMP DIA. B*	DIE SUFFIX #	SEE FIGURE #	CRIMP MACHINE SETTING
		± .015 mm ± .006 in			
FC254					
-12	1E12	36.50 mm 1.437 in	-82	12	
-16	1E16	45.40 mm 1.787 in	-46	12	
-20	1E20	53.20 mm 2.094 in	-14	12	
-24	1E24	61.15 mm 2.409 in	-20	12	
-32	1E32	73.65 mm 2.898 in	-23	12	
FC273, FC273B					
-12	1E12	36.70 mm 1.445 in	-82	12	
-16	1E16	45.40 mm 1.787 in	-46	12	
-20	1Z20	57.10 mm 2.248 in	-15	12	
-24	1Z24	64.15 mm 2.524 in	-16	12	
-32	1Z32	79.05 mm 3.114 in	-21	12	
FC606, FC606B					
-16	1Z16	49.10 mm 1.933 in	-46	12	
-20	1Z20	56.20 mm 2.213 in	-15	12	
-24	1Z24	64.15 mm 2.525 in	-16	12	
GH466					
-20	1Z20	56.90 mm 2.240 in	-15	12	
-24	1Z24	64.25 mm 2.531 in	-16	12	
GH506					
-12	1E12	36.20 mm 1.425 in	-82	12	
-16	1E16	44.90 mm 1.768 in	-46	12	
-20	1E20	53.50 mm 2.106 in	-14	12	
-24	1E24	60.40 mm 2.378 in	-20	12	
-32	1E32	73.65 mm 2.898 in	-23	12	
FC806					
-16	1E16	44.90 mm 1.768 in	-46	12	

Internal Skive Crimp Style

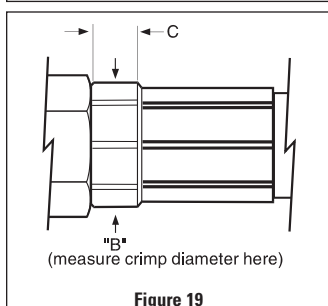
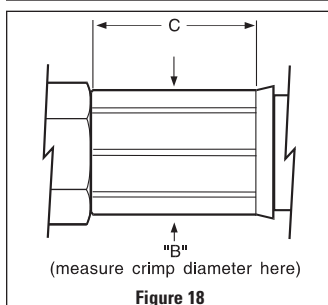
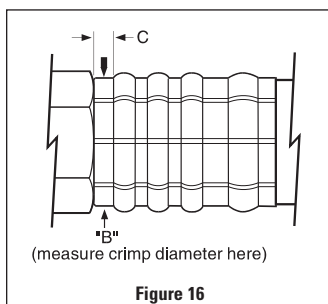
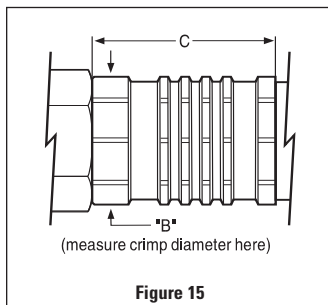
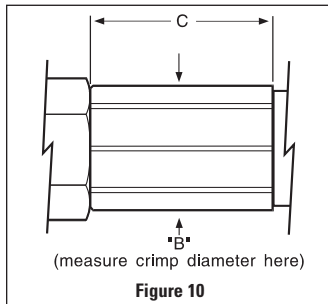
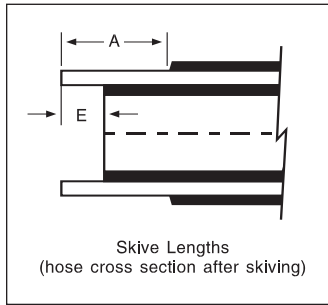

HOSE DASH SIZE	SOCKET PART #	SKIVE EXTERNAL LENGTH A	EXTERNAL TOOL	SKIVE INTERNAL LENGTH E	INTERNAL TOOL	CRIMP DIA. B*	CRIMP POS. C	DIE SUFFIX #	FIG. #	CRIMP MACHINE SETTING
		± .051mm ± .020 in		± .051mm ± .020 in		± .015mm ± .007 in	± .051mm ± .020 in			
FC254										
-08	FC2540	34.04 mm 1.340 in	FT1231-8	7.62 mm .300 in	FT1240-150-8	27.94 mm 1.100 in	**	-83 ¹ -M280 ¹	15	
-12	FC2717	35.56 mm 1.400 in	FT1231-12	11.18 mm .440 in	FT1240-150-12	35.56 mm 1.400 in	**	-82 ²	15	
-16	FC2540	46.99 mm 1.850 in	FT1231-16	11.94 mm .470 in	FT1240-150-16	41.53 mm 1.635 in	12.83 mm .505 in	-96 ²	16	
-20	FC2540	52.07 mm 2.050 in	FT1231-20	11.94 mm .470 in	FT1240-150-20	50.80 mm 2.000 in	**	-14 ²	15	
-24	FC2540	52.07 mm 2.050 in	FT1231-24	14.48 mm .570 in	FT1240-150-24	57.15 mm 2.250 in	**	-15 ²	15	
-32	FC2540	58.42 mm 2.300 in	FT1231-32	18.80 mm .740 in	FT1240-150-32	72.26 mm 2.845 in	**	-23 ²	15	
FC136										
-16	FC2540	46.99 mm 1.850 in	FT1231-16	11.94 mm .470 in	FT1240-150-16	41.53 mm 1.635 in	12.83 mm .505 in	-96 ²	16	
-20	FC2540	52.07 mm 2.050 in	FT1231-20	11.94 mm .470 in	FT1240-100-20	50.80 mm 2.000 in	**	-14 ²	15	
-24	FC2540	52.07 mm 2.050 in	FT1231-24	14.48 mm .570 in	FT1240-100-24	57.15 mm 2.250 in	**	-15 ²	15	
-32	FC2540	58.42 mm 2.300 in	FT1231-32	18.80 mm .740 in	FT1240-100-32	72.26 mm 2.845 in	**	-23 ²	15	
FC273										
-12	FC2717	35.56 mm 1.400 in	FT1231-12	11.18 mm .440 in	FT1240-100-12	36.07 mm 1.420 in	**	-82 ²	15	
-16	FC2540	46.99 mm 1.850 in	FT1231-16	11.94 mm .470 in	FT1240-150-16	42.29 mm 1.665 in	12.83 mm .505 in	-96 ²	16	
-20	FC2717	52.07 mm 2.050 in	FT1231-20	11.94 mm .470 in	FT1240-100-20	55.37 mm 2.180 in	**	-15 ²	15	
-24	FC2717	52.07 mm 2.050 in	FT1231-24	14.48 mm .570 in	FT1240-100-24	62.23 mm 2.450 in	**	-16 ²	15	
-32	FC2717	29.21 mm 1.150 in***	FT1231-32A	18.80 mm .740 in	FT1240-100-32	78.61 mm 3.095 in	**	-18 ²	15	
FC323, FC324										
-12	FC2717	35.56 mm 1.400 in	FT1231-12	11.18 mm .440 in	FT1240-100-12	35.56 mm 1.400 in	**	-82 ²	15	
-16	FC2540	46.99 mm 1.850 in	FT1231-16	11.94 mm .470 in	FT1240-150-16	42.04 mm 1.655 in	12.83 mm .505 in	-96 ²	16	
-20	FC2540	52.07 mm 2.050 in	FT1231-20	11.94 mm .470 in	FT1240-100-20	51.18 mm 2.015 in	**	-14 ²	15	
-24	FC2540	52.07 mm 2.050 in	FT1231-24	14.48 mm .570 in	FT1240-100-24	57.79 mm 2.275 in	**	-15 ²	15	
-32	FC2540	58.42 mm 2.300 in	FT1231-32	18.80 mm .740 in	FT1240-100-32	72.77 mm 2.865 in	**	-23 ²	15	
FC325										
-12	FC2717	35.56 mm 1.400 in	FT1231-12	11.18 mm .440 in	FT1240-100-12	35.94 mm 1.415 in	**	-82 ²	15	
-16	FC2540	46.99 mm 1.850 in	FT1231-16	11.94 mm .470 in	FT1240-150-16	42.72 mm 1.682 in	12.83 mm .505 in	-96 ²	16	
FC606										
-16	FC1601	57.15 mm 2.250 in	FT1229-16B	11.94 mm .470 in	FT1240-150-16	45.21 mm 1.780 in	**	-46 ²	10	
-20	FC1601	69.85 mm 2.750 in	FT1229-20B	11.94 mm .470 in	FT1240-150-20	53.64 mm .650 in	16.51 mm	-151 ²	19	

* Max. crimp ovality .30 mm/.012 in. 1 FT1320, FT1330 and FT1380 not approved.
 ** Crimp full length of socket. 2 FT1049-100-SIZE or FT1209-200-SIZE only.
 *** This is the correct measurement.

Spiral Single Skive Crimp Style

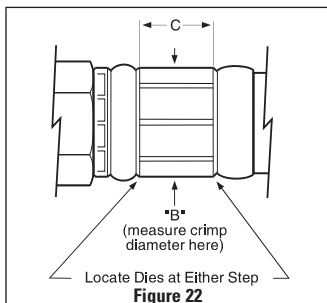
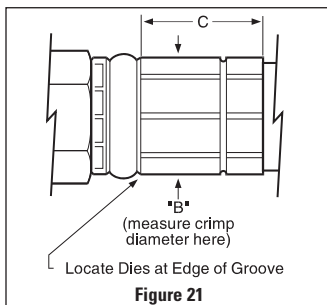
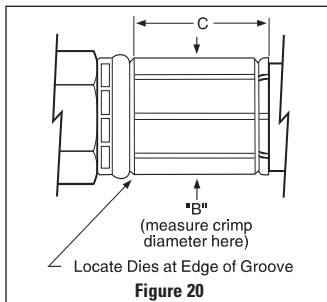
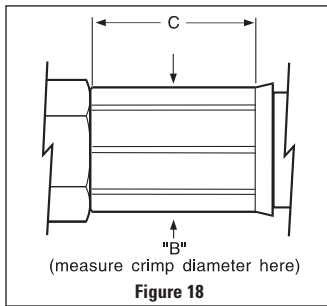
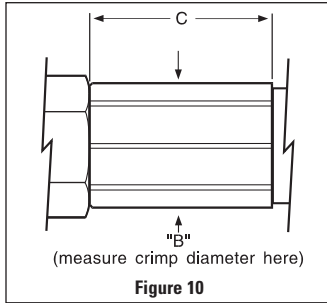
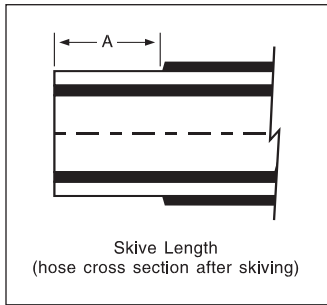

HOSE DASH SIZE	SOCKET PART #	SKIVE LENGTH A	CRIMP DIA. B*	CRIMP LENGTH C	DIE SUFFIX #	SEE FIGURE #	CRIMP MACHINE SETTING
		± .50 mm ± .020 in	± .18 mm ± .007 in	± .38 mm ± .015 in			

FC254							
-12	FC1414	35.60 mm	34.42 mm	37.47 mm	-M320 ¹	21	
	Pre-Crimped	1.400 in	1.355 in	1.475 in	-6 ¹	22	
-16	FC1414	47.00 mm	41.28 mm	39.50 mm	-M370 ¹	21	
	Pre-Crimped	1.850 in	1.625 in	1.555 in	-8 ¹	22	
-20	FC1410	47.80 mm	47.88 mm	46.99 mm	-M465 ¹	20	
	Pre-Crimped	1.880 in	1.885 in	1.850 in	-9 ¹		
-24	FC1410	55.40 mm	56.01 mm	52.32 mm	-M550	20	
	Pre-Crimped	2.180 in	2.205 in	2.060 in	-11		

FC273							
-12	FC1414	35.60 mm	34.42 mm	37.47 mm	-M320 ¹	21	
	Pre-Crimped	1.400 in	1.355 in	1.475 in	-6 ¹	22	
-16	FC1414	47.00 mm	41.28 mm	39.50 mm	-M370 ¹	21	
	Pre-Crimped	1.850 in	1.625 in	1.555 in	-8 ¹	22	

FC323							
-12	FC1410	30.70 mm	32.64 mm	37.47 mm	-M320	10	
		1.210 in	1.285 in	1.475 in	-6	18	
-16	FC1410	33.00 mm	38.86 mm	39.50 mm	-M370	10	
		1.300 in	1.530 in	1.555 in	-8	18	
-20	FC1410	47.80 mm	48.64 mm	46.99 mm	-M465 ¹	20	
	Pre-Crimped	1.880 in	1.915 in	1.850 in	-9 ¹		
-24	FC1410	55.40 mm	56.64 mm	52.32 mm	-M550	20	
	Pre-Crimped	2.180 in	2.230 in	2.060 in	-11		

FC324							
-08	FC1410	31.80 mm	24.13 mm	33.65 mm	-M240	10	
		1.250 in	.950 in	1.325 in	-4	18	
-12	FC1410	30.70 mm	32.64 mm	37.47 mm	-M320	10	
		1.210 in	1.285 in	1.475 in	-6	18	
-16	FC1410	33.00 mm	38.74 mm	39.50 mm	-M370 ¹	10	
		1.300 in	1.525 in	1.555 in	-8 ¹	18	

* Max. crimp ovality .30 mm/.012 in.
1 FT1320, FT1330 and FT1380 not approved.

HOSE DASH SIZE	SOCKET PART #	SKIVE LENGTH A	CRIMP DIA. B*	CRIMP LENGTH C	DIE SUFFIX #	SEE FIGURE #	CRIMP MACHINE SETTING
		± .50 mm ± .020 in	± .12 mm ± .005 in	± .38 mm ± .015 in			

FC736, GH493, FC136							
-06	FC3471	22.90 mm	20.74 mm	29.97 mm	-M210	10	
		.900 in	.817 in	1.180 in	-3	18	
-08	FC3471	26.40 mm	24.45 mm	33.65 mm	-M240	10	
		1.040 in	.963 in	1.325 in	-4	18	
-10	FC3471	30.00 mm	28.50 mm	36.32 mm	-M280	10	
		1.180 in	1.122 in	1.430 in	-5	18	
-12	FC1410	30.70 mm	32.64 mm	37.47 mm	-M320	10	
		1.210 in	1.285 in	1.475 in	-6	18	
-16	FC1410	33.00 mm	39.12 mm	39.50 mm	-M370	10	
		1.300 in	1.540 in	1.555 in	-8	18	
-20	FC1410	47.80 mm	48.64 mm	46.99 mm	-M465 ¹	20	
	Pre-Crimped	1.880 in	1.915 in	1.850 in	-9 ¹		
-24	FC1410	55.40 mm	56.64 mm	52.32 mm	-M550	22	
	Pre-Crimped	2.180 in	2.230 in	2.060 in	-11		
-32	FC1345	52.10 mm	71.37 mm	50.80 mm	-M690	22	
	Pre-Crimped	2.050 in	2.810 in	2.000 in	-23 ²		

* Max. crimp ovality .20 mm/.008 in.
1 FT1320, FT1330 and FT1380 not approved.
2 FT1209-200-23 not approved.

Crimp Equipment Accessories Reference

Die Cage Repair Kit



Complete cage, less dies.

To Repair

FT1209-200-SIZE
 FT1307-200-SIZE
 FT1330-200-SIZE
 FT1330-275-SIZE
 FT1380-200-SIZE
 FT1380-201-SIZE
 FT1380-275-SIZE
 FT1390-200-SIZE

Order Part No.

FT1209-2-9
 FT1307-2-9
 FT1330-2-9
 FT1330-2-9M
 FT1380-2-9
 FT1380-2-9A
 FT1380-2-9
 FT1390-2-9

MatchMate Plus Crimp Die Cage Decal Kit



Part No. JA286B

One sheet of pre-cut, color decals which match each of the six styles and all sizes of MatchMate Plus and MatchMate BLUE hose. These decals are to be applied to crimp die cages for ease of matching and mating hose to tooling.

FT1380-2-3 Die Cage Conversion Kit



Part No. FT1380-2-3

For use with FT1330 die cage so it can be used in an FT1380 crimp machine. Includes FT1380 backplate and installation instructions.

Removable Die Cage Kit



Part No. FT1307-2-13

For use with FT1204-100-SIZE individual dies to make a die cage.

Calidapters



Part No. FT1297

The Aeroquip FT1297 Calidapters can be attached to most calipers. These calidapters are ideal for measuring the crimp diameter of Aeroquip field crimp fittings after crimping.

MatchMate Plus Fitting Locators

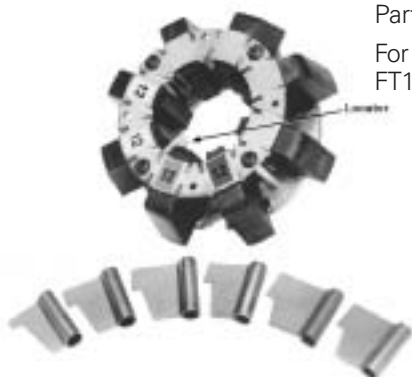

Part No. FT1330-XL

For use with FT1330 and FT1380 "M" series die cages.

Crimp Equipment and Die Suffix Reference

FT1008 Crimp Machine



Uses barrel crimp fittings only
Die part numbers:
FT1008-100-4 or
FT1008-100-5 only
Individual dies
Eight pieces required

Discontinued model. Replaced by FT1380.

FT1244 Crimp Machine



Die part number:
FT1204-100-SIZE
Individual dies
Eight pieces required

Discontinued model. Replaced by FT1390.

FT1049 Crimp Machine



Die part number:
FT1049-100-SIZE
Individual dies
Eight pieces required

Discontinued model. Replaced by FT1390.

FT1307 Crimp Machine



Die cage part numbers:
FT1307-200-SIZE or
FT1209-200-SIZE*

Discontinued model. Replaced by FT1390.

FT1204 Crimp Machine



Die part number:
FT1204-100-SIZE
Individual dies
Eight pieces required

Discontinued model. Replaced by FT1390.

FT1310 Mini-Crimp Machine



The FT1310 tooling part numbers correspond with the hose dash size, ie: -06 die set will crimp -06 hose. The tooling part numbers for other crimp machines in this bulletin do not apply to the FT1310 Mini-Crimp machine. For complete crimping details, refer to the owner's manual (FT1310-500).

FT1208 Crimp Machine



Die part number:
FT1208-100-SIZE
Individual dies
Eight pieces required

Discontinued model. Replaced by FT1380.

FT1320 Crimp Machine



Die cage part numbers:
FT1330-200-SIZE or
FT1330-275-SIZE

Discontinued model. Replaced by ET1280.

FT1209 Crimp Machine



Die cage part numbers:
FT1209-200-SIZE* or
FT1307-200-SIZE

Discontinued model. Replaced by FT1390.

* FT1209 die cages are for use with internal skive type fittings.

FT1330 Crimp Machine



Die cage part numbers:
FT1330-200-SIZE or
FT1330-275-SIZE

Discontinued model.
Replaced by FT1380.

Crimp Equipment and Die Suffix Reference

FT1340 Crimp Machine



Die cage part numbers:
FT1307-200-SIZE or
FT1209-200-SIZE*
Discontinued model. Replaced by FT1390.

ProCrimp™ 1380 Crimp Machine



Die cage part numbers:
FT1380-200-SIZE or
FT1380-275-SIZE

FT1360 Crimp Machine



Die cage part numbers:
FT1307-200-SIZE or
FT1209-200-SIZE*
Discontinued model. Replaced by FT1390.

FT1380P Crimp Machine



Die cage part numbers:
FT1380-200-SIZE or
FT1380-275-SIZE

Discontinued model. Replaced by ET1280.

FT1370 Crimp Machine



Die cage part numbers:
FT1380-200-SIZE or
FT1380-275-SIZE
Discontinued model. Replaced by ET1000.

ET1000 Crimp Machine



Collet part numbers:
ET400DC or ET1000DC or
ET420DC or T-400 or T-420

ProCrimp™ 1390 Crimp Machine



Die cage part numbers:
FT1307-200-SIZE or
FT1209-200-SIZE* or
FT1390-200-SIZE

ET1280 Crimp Machine



Die cage part numbers:
FT1380-200-SIZE or
FT1380-275-SIZE

* FT1209 die cages are for use with internal skive type fittings.

MatchMate Plus Crimp Machine

Target Settings

The FT1320 target settings are for use with the FT1320-550 crimp control sleeve. The FT1330 and FT1340 target settings are for use with the digital encoders on those machines. The FT1307 target settings are for use with the micrometer on the machine.

HOSE DASH SIZE	DIE CAGE	FT1320 -550 SLEEVE	FT1330	FT1360 AND FT1340	ET1280 AND FT1380	FT1390	TARGET DIA.
							± .15 mm ± .006 in
GH194 with TTC Fittings							
-4	-M150	51	760	855	067	233	15.75mm .620 in
	-2	72	555	836	-	-	
-6	-M180	59	680	810	095	261	19.56mm .770 in
	-3	60	675	950	-	-	
-8	-M240	43	838	922	036	199	23.88mm .940 in
	-4	70	574	842	-	-	
-10	-M240	70	576	720	147	311	26.80mm 1.055 in
	-5	60	674	918	-	-	
-12	-M320	42	850	936	024	193	31.75mm 1.250 in
	-6	75	518	810	-	-	
-16	-M370	74	531	688	166	332	40.39mm 1.590 in
	-8	85	419	730	-	-	
-20	-M420	-	518	670	176	340	45.72mm 1.800 in
GH195 with TTC Fittings							
-4	-M150	61	665	770	112	277	16.89mm .665 in
	-2	81	460	765	-	-	
-6	-M210	45	815	880	047	211	21.21mm .835 in
	-3	73	535	810	-	-	
-8	-M240	53	735	824	087	247	25.15mm .990 in
	-4	80	470	736	-	-	
-10	-M280	48	791	859	063	230	28.71mm 1.130 in
-12	-M320	48	790	895	049	223	32.51mm 1.280 in
	-6	81	460	770	-	-	
-16	-M370	83	325	598	216	381	41.66mm 1.640 in
	-8	95	450	640	-	-	
-20	-M465	-	466	636	194	361	50.80mm 2.000 in
	-9	-	-	744	-	-	
-24	-M550	-	-	760	-	297	57.66mm 2.270 in
	-11	-	-	805	-	-	
-32	-M690	-	-	855	-	244	70.36mm 2.770 in
	-23	-	-	710	-	-	

HOSE DASH SIZE	DIE CAGE	FT1320 -550 SLEEVE	FT1330	FT1360 AND FT1340	ET1280 AND FT1380	FT1390	TARGET DIA.
							± .15 mm ± .006 in
GH663 with TTC Fittings							
-4	-M150	50	770	854	068	237	15.75mm .620 in
	-2	71	560	855	-	-	
-6	-M180	62	650	766	104	275	19.94mm .785 in
	-3	62	645	902	-	-	
-8	-M240	42	850	920	034	199	23.88mm .940 in
	-4	68	585	828	-	-	
-10	-M240	57	700	712	-	-	26.80mm 1.055 in
	-5	62	650	724	-	-	
-12	-M320	41	855	950	018	191	31.75mm 1.250 in
	-6	73	535	830	-	-	
-16	-M370	72	545	688	161	331	40.39mm 1.590 in
	-8	83	435	730	-	-	
-20	-M420	-	490	650	187	351	46.00mm 1.811 in
					-	-	
GH781 with TTC Fittings							
-4	-M150	60	665	775	111	286	16.89mm .665 in
	-2	80	470	760	-	-	
-6	-M210	41	855	915	026	200	20.70mm .815 in
	-3	68	585	844	-	-	
	-M180	69	580	704	-	-	
-8	-M240	50	765	846	071	234	24.77mm .975 in
	-4	77	500	760	-	-	
-10	-M280	46	810	890	045	214	28.32mm 1.115 in
	-5	72	545	810	-	-	
-12	-M320	39	875	960	013	184	31.62mm 1.245 in
	-6	73	540	835	-	-	
-16	-M370	66	605	728	137	306	39.75mm 1.565 in
	-8	78	490	780	-	-	
-20	-M465	-	680	806	091	262	48.26mm 1.900 in
	-9	-	-	915	-	-	
-24	-M550	-	-	-	-	182	54.74mm 2.155 in
-32	-M690	-	-	-	-	175	68.58mm 2.700 in

To determine the target setting, refer to the equipment operator's manual.

MatchMate Plus Crimp Machine

Target Settings

HOSE DASH SIZE	DIE CAGE	FT1320 -550 SLEEVE	FT1330	FT1360 AND FT1340	ET1280 AND FT1380	FT1390	TARGET DIA.
							± .15 mm ± .006 in
GH793 with TTC Fittings							
-4	-M150	63	635	740	125	302	17.27mm
	-2	84	430	735	-	-	.680 in
-6	-M210	45	815	880	046	211	21.21mm
	-3	73	535	810	-	-	.835 in
-8	-M240	53	735	824	086	247	25.15mm
	-4	80	470	736	-	-	.990 in
-10	-M280	50	770	865	061	230	28.70mm
	-5	76	505	785	-	-	1.130 in
-12	-M320	48	790	895	048	222	32.51mm
	-6	81	460	770	-	-	1.280 in
-16	-M370	81	460	618	204	371	41.40mm
	-8	92	345	660	-	-	1.630 in
-20	-M465	-	560	706	149	320	49.78mm
	-9	-	-	814	-	-	1.960 in
-24	-M550	-	-	760	-	297	57.66mm
	-11	-	-	805	-	-	2.270 in
	-M570	-	-	868	-	-	
-32	-M690	-	-	815	-	266	70.87mm
	-23	-	-	670	-	-	2.790 in
	-17	-	-	745	-	-	

HOSE DASH SIZE	DIE CAGE	FT1320 -550 SLEEVE	FT1330	FT1360 AND FT1340	ET1280 AND FT1380	FT1390	TARGET DIA.
							± .15 mm ± .006 in
GH493 with TTC12 Fittings							
-6	-M210	59	680	784	105	271	22.76mm
	-4	56	708	915	-	-	.896 in
-8	-M280	41	855	936	025	191	27.81mm
	-5	68	590	855	-	-	1.095 in
-10	-M280	64	633	721	130	298	30.48mm
							1.200 in
-12	-M320	64	625	758	120	296	34.42mm
	-6	97	300	630	-	-	1.355 in
-16	-M420	-	690	802	100	264	43.82mm
	-8	-	145	-	-	-	1.725 in
	-M370	-	250	-	290	-	
-20	-M520	-	-	920	-	197	52.20mm
	-M465	-	360	-	239	-	2.055 in
-24	-M550	-	-	885	-	226	55.88mm
	-11	-	-	945	-	-	2.200 in
-32	-M690	-	-	945	-	188	69.16mm
							2.723 in

To determine the target setting, refer to the equipment operator's manual.

NOTE: These target settings for Aeroquip crimp machines are provided to aid in establishing actual settings. While the settings on this chart will give crimp diameters close to, or at, the specified value, the machine operator must check to verify the actual diameter. Before using these target settings, the crimp machine must be properly calibrated. Consult your Aeroquip equipment manual for calibration procedures.

Aeroquip Crimp Machine Capabilities with MatchMate Plus Fittings

CURRENT MODELS	TTC	TTC12
ET1000	Thru -20	Thru -16
FT1380, ET1280	Thru -20	Thru -20
FT1390	All sizes	All sizes

PREVIOUS MODELS	TTC	TTC12
FT1049*, FT1204, FT1209, FT1244, FT1307, FT1340 and FT1360	All sizes	All sizes
FT1208	Thru -12	Thru -12
FT1310	Thru -16	N/A
FT1320	Thru -16	Thru -12
FT1330 Model "A"***	Thru -16	Thru -12
FT1330 Model "B", FT1380P	Thru -20	Thru -20
FT1370	Thru -20	Thru -16

* Requires the addition of an FT1049-130-5 backstop spring for crimping TTC and TTC12 fittings.

** Model "A" discontinued in September 1991.

Tooling Compatibility Chart

CRIMP MACHINES																		
TOOLING	FT1008	FT1049	FT1204	FT1208	FT1209	FT1244	FT1307	FT1310	FT1320	FT1330	FT1340	FT1360	FT1370	FT1380	FT1380P	FT1390	ET1000	ET1280
FT1008-100-SIZE	X																	
FT1049-100-SIZE		X																
FT1204-100-SIZE			X		X ¹	X	X ¹				X ¹	X ¹				X ¹		
FT1208-100-SIZE				X														
FT1209-200-SIZE					X		X				X	X				X		
FT1307-200-SIZE					X		X				X	X				X		
FT1310-200-SIZE								X										
FT1330-200-SIZE									X	X								
FT1330-275-SIZE									X	X								
FT1380-200-SIZE														X	X	X		X
FT1380-201-SIZE														X	X	X		X
FT1380-275-SIZE														X	X	X		X
FT1390-200-SIZE					X		X				X	X				X		
ET400-SIZE																		X
ET420-SIZE																		X
ET1000-SIZE																		X
T-400-SIZE																		X
T-420-SIZE																		X

¹ Individual dies. Requires the use of die cage kit FT1307-2-9 or removable die cage FT1307-2-13.

Eaton
14615 Lone Oak Road
Eden Prairie, MN 55344
USA
Tel: 952 937-9800
Fax: 952 974-7722
www.hydraulics.eaton.com

Eaton
20 Rosamond Road
Footscray
Victoria 3011
Australia
Tel: (61) 3 9319 8222
Fax: (61) 3 9318 5714

Eaton
Dr.-Reckeweg-Str. 1
D-76532 Baden-Baden
Germany
Tel: (49) 7221 682-0
Fax: (49) 7221 682-788



Aeroquip

© 2005 Eaton Corporation
All Rights Reserved
Printed in USA
Document No. A-EQCR-TM001-E
Supersedes JA55G
November 2005