

Copyright

Fujitsu PC Corporation has made every effort to ensure the accuracy and completeness of this document. However, as ongoing development efforts are continually improving the capabilities of our products, we cannot guarantee the accuracy of the contents of this document. We disclaim liability for errors, omissions, or future changes.

Fujitsu, the Fujitsu logo, and LifeBook are registered trademarks of Fujitsu Limited.

The following are registered trademarks of Microsoft Corporation: MS, MS-DOS, Windows.

PCMCIA is a trademark of the Personal Computer Memory Card International Association.

Intel and Pentium are registered trademarks and SpeedStep is a trademark of Intel Corporation or its subsidiaries in the United States and other countries.

Adobe Acrobat Reader is a registered trademark of Adobe System Inc.

Earthlink is a registered trademark of EarthLink Network, Inc.

Quicken is a registered trademark of Intuit, Inc.

Sony MiniDisk is a trademark of Sony Electronics, Inc.

Philips is a trademark of Koninklijke Philips Electronics N.V.

WinDVD is a trademark of InterVideo, Inc.

Netscape 6 is a registered trademark of Netscape Communications Corporation.

PowerQuest and Drive Image are registered trademarks of PowerQuest Corp.

ATI and Radeon are registered trademarks of ATI Technologies, Inc.

McAfee is a registered trademark of Network Associates/McAfee.com, Inc.

BayManager is a registered trademark of Softex, Inc.

The DVD player found in some models of the LifeBook notebook incorporates copyright protection technology that is protected by method claims of certain U.S. patents and other intellectual property rights owned by Macrovision Corporation and other rights users. Use of this copyright protection technology must be authorized by Macrovision Corporation, and is intended for home and other limited viewing uses only unless authorized by Macrovision Corporation. Reverse engineering or disassembly is prohibited.

Dolby Headphone manufactured under license from Dolby Laboratories. "Dolby", "Pro Logic", and the double-D symbol are trademarks of Dolby Laboratories. Confidential Unpublished works. Copyrights 1992-1999 Dolby Laboratories. All rights reserved.

All other trademarks mentioned herein are the property of their respective owners.

© Copyright 2002 Fujitsu PC Corporation. All rights reserved. No part of this publication may be copied, reproduced, or translated, without prior written consent of Fujitsu PC Corporation. No part of this publication may be stored or transmitted in any electronic form without the written consent of Fujitsu PC Corporation.

B5FH-5281-01EN-00



DECLARATION OF CONFORMITY

according to FCC Part 15

Responsible Party Name:	Fujitsu PC Corporation
Address:	5200 Patrick Henry Drive Santa Clara, CA 95054
Telephone:	(408) 982-9500
Declares that product:	Model Configurations: LifeBook E7010 LifeBook E7110 Complies with Part 15 of the FCC Rules.

This device complies with Part 15 of the FCC rules. Operations are subject to the following two conditions: (1) This device must not be allowed to cause harmful interference, (2) This device must accept any interference received, including interference that may cause undesired operation.

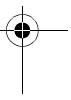
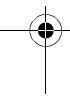

LifeBook E Series

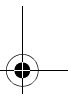
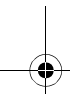
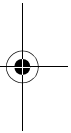
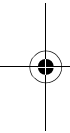

Fujitsu LifeBook® E Series

Table of Contents

1

PREFACE

Preface

About This Guide	3
Fujitsu Contact Information	3
Warranty	3

2

GETTING TO KNOW YOUR LIFEBOOK NOTEBOOK

Overview

Unpacking	7
---------------------	---

Locating the Controls and Connectors

Top and Front Components	8
Left-Side Panel Components	10
Right-Side Panel Components	11
Back Panel Components	12
Bottom Components	13

Status Indicator Panel

Power Indicator	14
AC Adapter Indicator	14
Battery Level Indicators	14
Battery Charging Indicators	15
Media Drive Access Indicator	15
Hard Drive or Removable Media Drive Access Indicator	15
Floppy Disk Drive Access Indicator	15
PC Card Access Indicators	15
NumLk Indicator	15
CapsLock Indicator	16
ScrLk Indicator	16
Security Indicator	16

Keyboard

Using the Keyboard	17
Numeric Keypad	17
Windows Keys	17
Cursor Keys	17
Function Keys	18

Wireless Infrared Mouse

Preparing Your IR Mouse for Use	19
---	----

TouchPad Pointing Device

Clicking	21
Double-Clicking	21
Dragging	22
TouchPad Control Adjustment	22

Flexible Bay Devices

Removing and Installing Modular Devices	23
---	----

LifeBook Security/Application Panel

Setting up Your LifeBook Security Panel	26
Passwords	26
Operating Your LifeBook Security Application Panel	27
Precautions	27
Uninstalling the Security Panel Application	27
Launching Applications with the Security/Application Panel	28

3

GETTING STARTED

Power Sources

Connecting the Power Adapters	33
---	----

Display Panel

Opening the Display Panel	34
Adjusting Display Panel Brightness	34
Closing the Display Panel	34

Starting Your LifeBook Notebook

Power On	35
Boot Sequence	35
BIOS Setup Utility	35
Booting the System	36
Windows Product Activation (Windows XP Only)	36
Registering Your LifeBook Notebook	37
Installing Click Me!	37

Power Management

Power and Suspend/Resume Button	38
Suspend Mode	38
Hibernation (Save-to-disk) Feature	39
Display Timeout	39
Hard Disk Timeout	39
Windows 98 Second Edition Power Management	39
Restarting the System	40
Power Off	40

4

USER-INSTALLABLE FEATURES

Lithium ion Battery

Recharging the Batteries	43
Replacing the Battery	44

External USB Floppy Disk Drive

Loading a Disk	45
Ejecting a Disk	45
Preparing a Disk for Use	45

Media Drive

Media Player Software	46
Loading a DVD, CD, CD-R, CD-RW, or Combo ("Media")	46
Removing Media	47
Emergency DVD/CD-ROM Tray Release	47
Using the Media Player Software	47
Using Dolby Headphone	48
Using the Media Player on Battery Power	48
Auto Insert Notification Function	49

Hard Disk Drive

Formatting the Hard Disk Drive	50
--------------------------------------	----

PC Cards

Installing PC Cards	51
Removing PC Cards	51
SmartCard Reader	52

Memory Upgrade Module

Installing a Memory Upgrade Module	53
Removing a Memory Upgrade Module	53
Checking the Computer Recognition of New Memory Capacity	54

Device Ports

Communications Ports	55
LAN Port	55
IEEE 1394 Jack	55
Parallel Port	55
Serial Port	55
PS/2 Port	55
Universal Serial Bus Ports	55
Infrared Port	55
Wireless Infrared Mouse Port	56
Microphone Jack	56
S-Video Out Port	56
Headphone/SPDIF Jack	56
Docking Port	57
External Monitor Port	57

5

TROUBLESHOOTING

Troubleshooting

Fujitsu Service Assistant	61
Identifying the Problem	61
Specific Problems	62
Troubleshooting Table	62
Power On Self Test Messages	70
Modem Result Codes	71

Restoring Your Pre-installed Software

Drive Image Special Edition (DISE)	72
Using DISE with Windows 2000/XP	72
Installing and Using DISE with Windows 98	73

6

CARE AND MAINTENANCE

Care and Maintenance

LifeBook Notebook	77
Batteries	78
Floppy Disks and Drives	78
DVDs and CDs	78
PC Cards	79

7

SPECIFICATIONS

Specifications

Configuration Label	83
Microprocessor	83
Memory	83
Video	83
Audio	83
Mass Storage Device Options	83
Features	83
Device Ports	84
Power	84
Dimensions	84
Environmental Requirements	84
Popular Accessories	85
Pre-Installed Software	86
CD-Based Software	86
Application Descriptions	87

8

GLOSSARY

Glossary	91
--------------------	----

REGULATORY INFORMATION

Notice	97
------------------	----

Appendix

INTEGRATED WIRELESS LAN USER'S GUIDE

FCC Regulatory Information	103
Before Using This Device	104
Connecting Windows 98/2000 Systems	105
Network Connection: Windows 98	106
Network Connection: Windows 2000	108
Connecting Windows XP Systems	111
Troubleshooting	115
If a Second LAN Device is Installed	121
About IP Addresses	121
Wireless LAN Specifications	122

LifeBook E Series

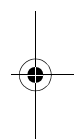
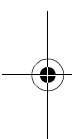

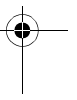
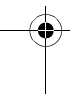

1 Preface

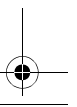
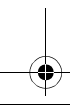
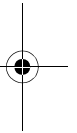
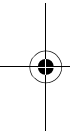

LifeBook E Series - Section 1

Preface

ABOUT THIS GUIDE

The LifeBook® E Series notebook from Fujitsu PC Corporation is a powerful notebook computer. It is powered by an Intel microprocessor, has a built-in color display, a number of possible configurations, and brings the computing power of desktop personal computers (PCs) to a portable environment.

This manual explains how to operate your LifeBook notebook's hardware and built-in system software. Your notebook is compatible with the IBM® PC AT.

It comes with Microsoft® Windows® 98 Second Edition, Windows 2000 Professional, Windows XP Home Edition, or Windows XP Professional pre-installed.

The LifeBook notebook is a completely self-contained unit with either an active-matrix XGA or SXGA+ TFT color LCD display. It has a powerful interface that enables it to support a variety of optional features.

Conventions Used in the Guide

Keyboard keys appear in brackets.

Example: [Fn], [F1], [ESC], [ENTER] and [CTRL].

Pages with additional information about a specific topic are cross-referenced within the text.

Example: (*See page xx.*)

On screen buttons or menu items appear in bold

Example: Click **OK** to restart your LifeBook notebook.

DOS commands you enter appear in Courier type.

Example: Shut down the computer?

POINT

The point icon highlights information that will enhance your understanding of the subject material.

CAUTION

The caution icon highlights information that is important to the safe operation of your computer, or to the integrity of your files. Please read all caution information carefully.

WARNING

The warning icon highlights information that can be hazardous to either you, your LifeBook notebook, or your files. Please read all warning information carefully.

FUJITSU CONTACT INFORMATION

Service and Support

You can contact Fujitsu Service and Support the following ways:

- Toll free: 1-800-8Fujitsu (1-800-838-5487)
- Fax: 1-901-259-5700
- E-mail: 8fujitsu@fujitsupc.com
- Web site: <http://www.fujitsupc.com>

Before you place the call, you should have the following information ready so that the customer support representative can provide you with the fastest possible solution:

- Product name
- Product configuration number
- Product serial number
- Purchase date
- Conditions under which the problem occurred
- Any error messages that have occurred
- Hardware configuration
- Type of device connected, if any

Fujitsu Online

You can go directly to the online Fujitsu Product catalog for your LifeBook notebook by clicking on the LifeBook Accessories Web site URL link, located in the Windows Start menu.

You can also reach Fujitsu Service and Support online by clicking on the Fujitsu Service and Support Web site URL link, located in the Service and Support Software folder of the Windows Start menu.

POINT

You must have an active internet connection to use the on-line URL links.

WARRANTY

Depending upon the configuration of your LifeBook notebook, your system is backed by either a one-year or three-year International Limited Warranty. Check the information that came with your LifeBook notebook for further warranty terms and conditions.

LifeBook E Series - Section 1



2

Getting to Know Your LifeBook Notebook

LifeBook E Series - Section 2

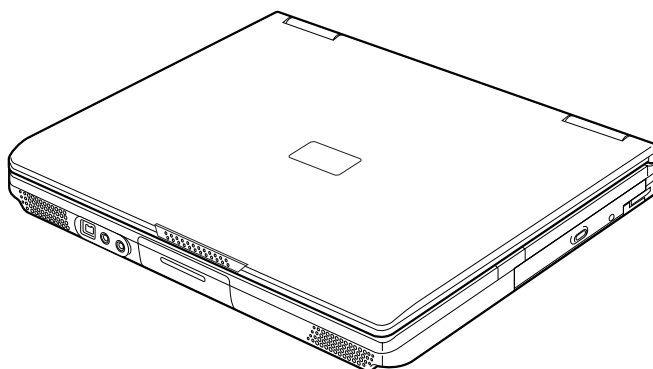

Figure 2-1. LifeBook E Series

Overview

This section describes the components of your Fujitsu LifeBook notebook. We strongly recommend that you read it before using your LifeBook notebook – even if you are already familiar with notebook computers.

UNPACKING

When you receive your LifeBook notebook, unpack it carefully, and compare the parts you have received with the items listed below.

For a pre-configured model you should have:

- LifeBook E Series notebook computer (*Figure 2-1*)
- Lithium ion battery, pre-installed
- AC adapter with AC power cord (*Figure 2-2*)
- USB floppy disk drive
- Weight Saver
- Phone/Modem (RJ-11) telephone cable
- Drivers and Applications Restore CD
- Getting Started Guide
- User's Guide (this guide)
- Fujitsu Service Assistant CD
- International Limited Warranty Brochure
- Microsoft-associated materials
- Premium Care registration card and envelope

Depending upon the configuration of your system, one or more of the following items may also be included in the box:

- Infrared (IR) Mouse (*Figure 2-3*)
- DVD Application CD
- CD-RW Application CD
- Additional battery(ies)

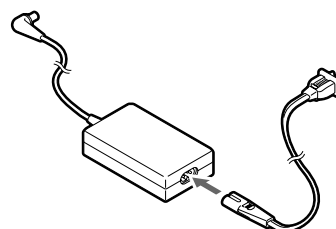

Figure 2-2. AC Adapter

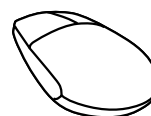

Figure 2-3. Infrared Mouse

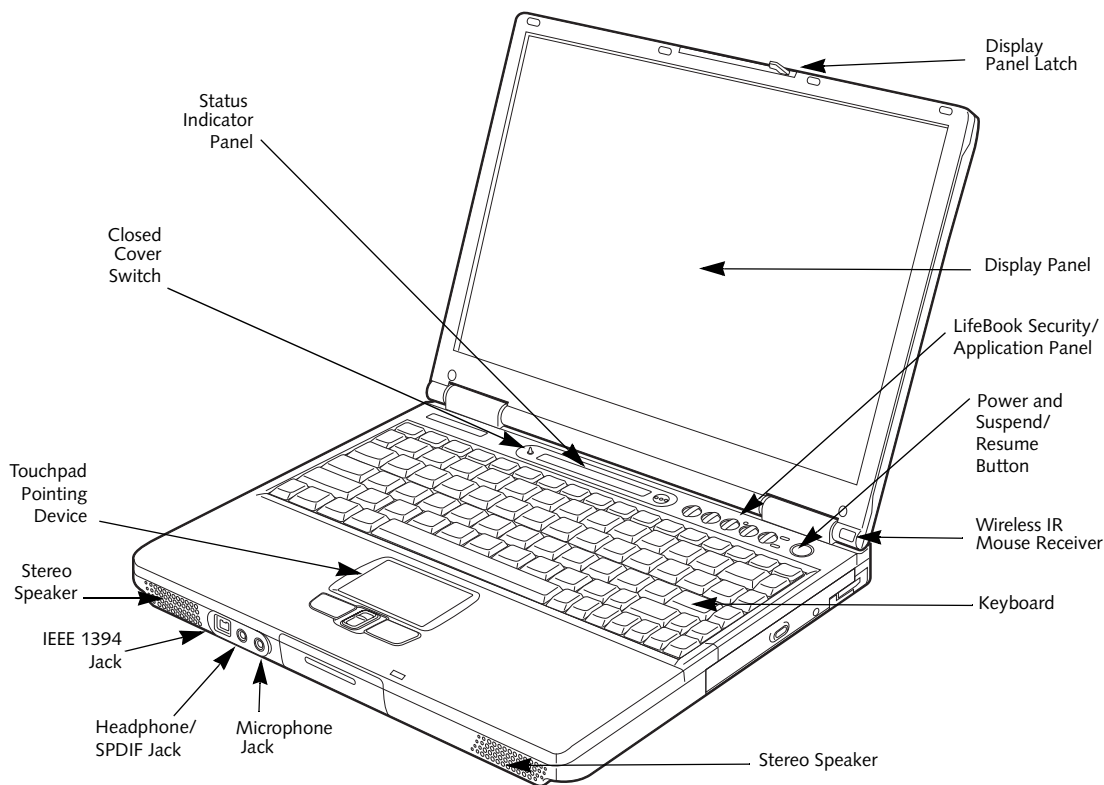

Figure 2-4. LifeBook notebook with display open

Locating the Controls and Connectors

TOP AND FRONT COMPONENTS

The following is a brief description of your LifeBook notebook's top and front components.

Display Panel Latch

The display panel latch locks and releases the display panel.

Display Panel

The display panel is a color LCD panel with back lighting for the display of text and graphics.

Status Indicator Panel

The Status Indicator Panel displays symbols that correspond with specific components of your LifeBook notebook. (See *Status Indicator Panel on page 14 for more information*)

Wireless IR Mouse Receiver

The Wireless IR Mouse Receiver allows you to use a wireless IR Mouse.

Power and Suspend/Resume Button

The Power and Suspend/Resume button is always used to Power On your LifeBook notebook from its Off state. It is also used as the Suspend/Resume button. This allows you to suspend notebook activity without powering off, resume your notebook from suspend mode, and power on your LifeBook notebook when it has been shut down. (See *Power On on page 35 for more information*) and (See *Power and Suspend/Resume Button on page 38 for more information*)

Stereo Speakers

The built-in dual speakers allow for stereo sound.

Closed Cover Switch

The closed cover switch turns off the LCD backlighting when the display panel is closed.

Keyboard

A full-size keyboard with dedicated Windows keys.
(See *Using the Keyboard on page 17 for more information*)

Touchpad Pointing Device

The pointing device is a Touchpad that allows you simple cursor control. (See *TouchPad Pointing Device on page 21 for more information*)

LifeBook Security/Application Panel

The LifeBook Security/Application Panel provides hardware security and one-touch application launch capability. (See *LifeBook Security/ Application Panel on page 26 for more information*)

Microphone Jack

The microphone jack allows you to connect an external mono microphone. (See *Microphone Jack on page 56 for more information*)

Headphone/SPDIF Jack

The headphone/SPDIF jack allows you to connect headphones or powered external speakers. (See *Headphone/SPDIF Jack on page 56 for more information*)

The SPDIF jack allows you to download digital audio onto a MiniDisc recorder's SPDIF (Sony Philips Digital Interface) format. (See *Optical Digital Audio-Out Connector on page 49 for more information*)

IEEE 1394 Jack

The 1394 jack is used to connect between your LifeBook notebook and a peripheral device such as a digital video camera. See "IEEE 1394 Jack" on page 55.

LifeBook E Series – Section 2

Figure 2-5. LifeBook notebook left-side panel

LEFT-SIDE PANEL COMPONENTS

Following is a brief description of your LifeBook notebook's left-side components.

Modem Port

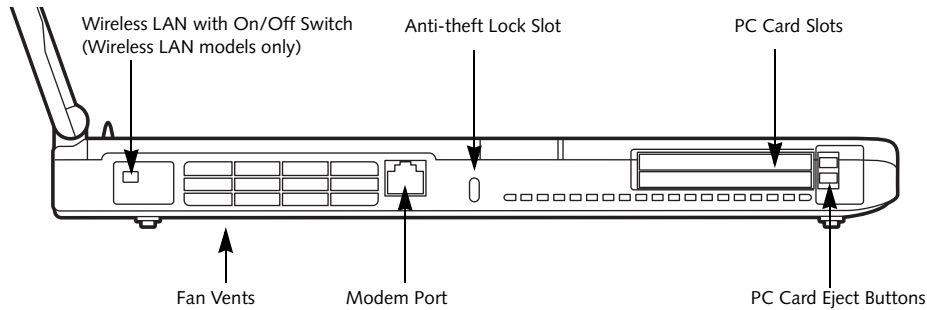
The modem port is designed to accept a Modem (RJ-11) telephone jack for the multi-national internal 56K modem. (See *Communications Ports on page 55 for more information*)

Wireless LAN On/Off Switch

(On wireless LAN models only)

The Wireless LAN On/Off Switch turns the wireless LAN device on and off.



POINT

The internal modem is designed to the ITU-T V.90 standard. Its maximum speed of 53000bps is the highest allowed by FCC, and its actual connection rate depends on the line conditions. The maximum upload speed is 33600bps.



CAUTION

The internal modem is not intended for use with Digital PBX systems. Do not connect the internal modem to a digital PBX as it may cause serious damage to the internal modem or your entire LifeBook notebook. Consult your PBX manufacturer's documentation for details. Some hotels have Digital PBX systems. Be sure to find out BEFORE you connect your modem. Third-party hardware is available to allow modem-to-PBX interface.

PC Card Slots

The PC Card Slots allow you to install two Type I or Type II PC Cards or one Type III PC Card. (See *PC Cards on page 51 for more information*)

Anti-theft Lock Slot

The anti-theft lock slot allows you to attach an optional physical lock down device.

Fan Vents

The fan vents assist in the proper cooling of the system.

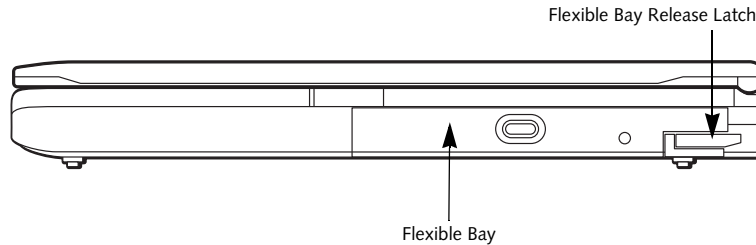

Figure 2-6. LifeBook notebook right-side panel

RIGHT-SIDE PANEL COMPONENTS

Following is a brief description of your LifeBook notebook's right-side components.

Flexible Bay

The Flexible Bay can accommodate one of the following devices. (See *Flexible Bay Devices on page 23 for more information*)

- Modular DVD/CD-RW combo drive
- Modular DVD drive
- Modular CD-ROM drive
- Modular Lithium ion bay battery

Flexible Bay Release Latch

The Flexible Bay release latch releases the Flexible Bay device.

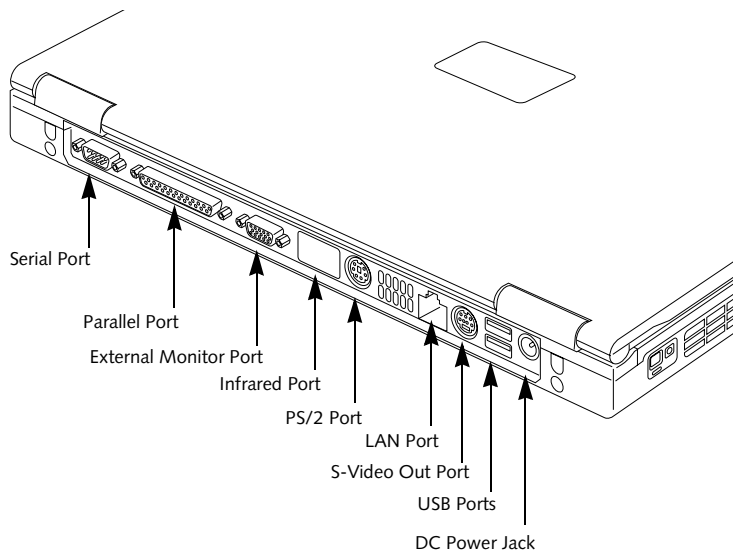

Figure 2-7. LifeBook notebook back panel

BACK PANEL COMPONENTS

Following is a brief description of your LifeBook notebook's rear panel components.

Serial Port

The serial port allows you to connect serial (RS-232C) devices. (This is also sometimes referred to as a COMM port.) (See *Serial Port on page 55 for more information*)

Parallel Port

The parallel port allows you to connect parallel devices. (This is also sometimes referred to as an LPT port.) (See *Parallel Port on page 55 for more information*)

External Monitor Port

The external monitor port allows you to connect an external monitor. (See *External Monitor Port on page 57 for more information*)

Infrared Port

The fast IrDA compatible port allows you to communicate with another IrDA compatible infrared device without a cable.

PS/2 Port

The PS/2 port allows you to connect an external PS/2 keyboard, mouse or numeric keypad. (See *PS/2 Port on page 55 for more information*)

LAN Port

The LAN port is designed to accept a Local Area Network (LAN) RJ-45 jack. (See *Communications Ports on page 55 for more information*)

S-Video Out Port

The S-Video out port is used to transmit a higher resolution video signal to a compatible TV or VCR. (See *S-Video Out Port on page 56 for more information*)

USB Ports

The USB ports allow you to connect Universal Serial Bus devices. (See *Universal Serial Bus Ports on page 55 for more information*)

DC Power Jack

The DC power jack allows you to plug in the AC adapter or the optional Auto/Airline adapter to power your LifeBook notebook and charge the internal Lithium ion battery.

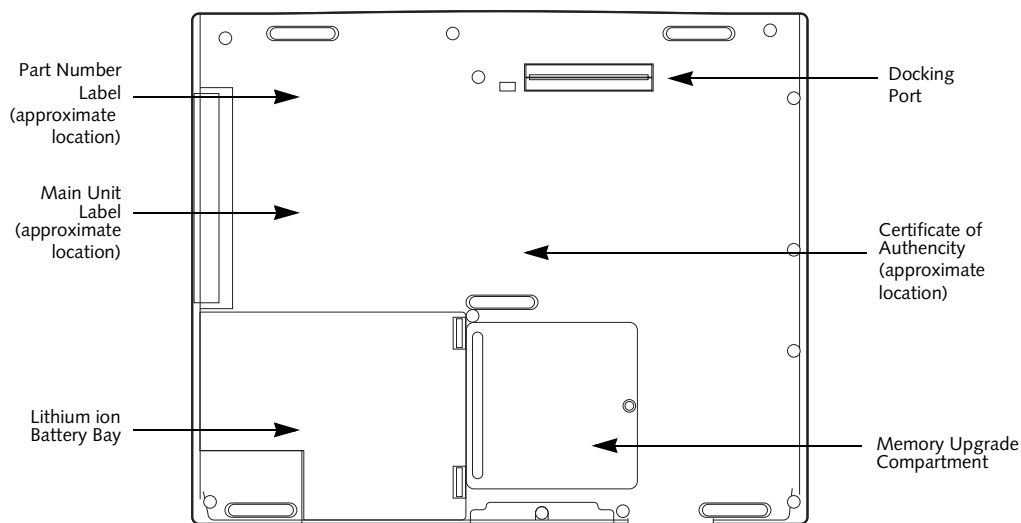

Figure 2-8. LifeBook notebook bottom panel

BOTTOM COMPONENTS

Following is a brief description of your LifeBook notebook's bottom panel components.

Configuration Label and Version Label

The configuration label shows the configuration part number, the Fujitsu part number, and the various components that make up your LifeBook notebook. The version label contains the system part number and serial number. These labels provide manufacturer information that you will need to give your support representative in the event you find it necessary to contact Fujitsu.

Lithium ion Battery Bay

The battery bay contains the internal Lithium ion battery. It can be opened for the removal of the battery when stored over a long period of time or for swapping a discharged battery with a charged Lithium ion battery. (See *Lithium ion Battery* on page 43 for more information)

Docking Port

The docking port allows you to connect an optional port replicator or docking station. (See *Docking Port* on page 57 for more information)

Memory Upgrade Compartment

Your LifeBook notebook comes with high speed PC2100 DDR266 SO-DIMM memory. The memory upgrade compartment allows you to expand the system memory capacity of your LifeBook notebook, hence improving overall performance. (See *Memory Upgrade Module* on page 53 for more information)

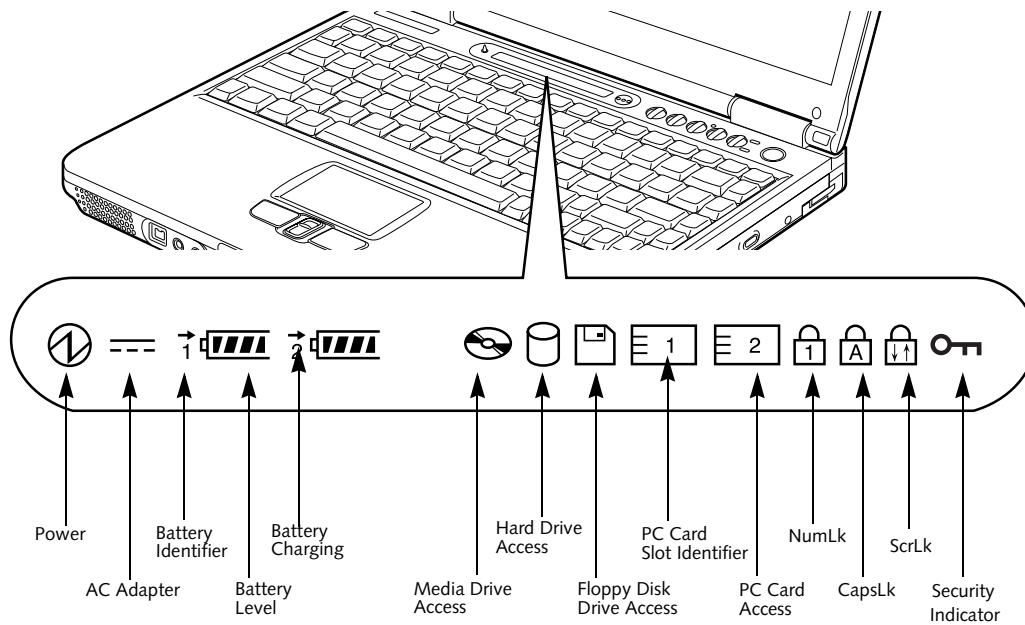

Figure 2-9 Status Indicator Panel

Status Indicator Panel

The Status Indicator panel is located in the recess just above your keyboard. Within this panel are symbols that correspond with a specific component of your LifeBook notebook. These symbols tell you how each of those components are operating. (Figure 2-9)

POWER INDICATOR

The Power indicator symbol states whether your system is operational. It has several different states, each of which tells you what mode your LifeBook notebook is in at that time.

- **Steady On:** This means that there is power to your LifeBook notebook and that it is ready for use.
- **Flashing:** This means that your LifeBook notebook is in Suspend mode.
- **Steady Off:** This means that your system is either in Save-to-Disk mode, or that your LifeBook notebook has been turned off with the power switch.

If you are charging your battery, the Power indicator symbol remains on even if your notebook is shut off. The Power indicator symbol will also remain on if you have either adapter connected and are shut down from Windows, but have not turned off the power switch.

AC ADAPTER INDICATOR

The AC Adapter indicator states whether your LifeBook notebook is operating from the AC adapter, the Auto/Airline adapter or the batteries. This icon has two

different states that can tell you what power source your LifeBook notebook is using.

- **On:** This means that either of the adapters are currently in use.
- **Off:** Power is only coming from the batteries, and you do not have an adapter connected.

BATTERY LEVEL INDICATORS

The two Battery Level indicators state whether or not the primary Lithium ion battery and/or the optional second Lithium ion battery are installed (Battery 1 refers to the primary Lithium ion battery, while Battery 2 refers to the Flexible Bay optional second battery). In addition, this symbol states how much charge is available within each installed battery. The symbol will only be displayed for a battery that is currently installed in your LifeBook notebook. (Figure 2-10)

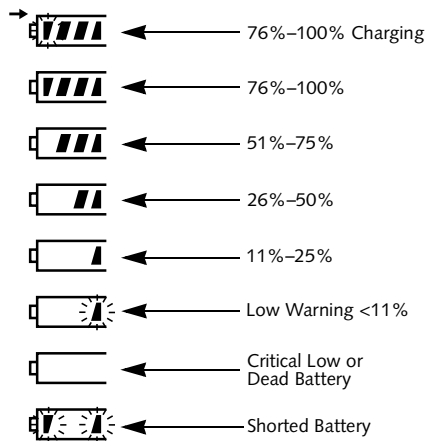

Figure 2-10 Battery Level Indicator

CAUTION

A shorted battery is damaged and must be replaced immediately.

POINT

If there is no battery activity, the power adapters are not connected, and the power switch is Off, the Battery Level indicators will also be off.

→ BATTERY CHARGING INDICATORS

Located to the left of each of the Battery Level indicators is a small arrow symbol. This symbol states whether that specific battery is charging. This indicator operates whether the power switch is in the On or Off position, and will flash if the battery is too hot or cold to charge.

CAUTION

Batteries subjected to shocks, vibration or extreme temperatures can be permanently damaged.

MEDIA DRIVE ACCESS INDICATOR

The Media Drive Access indicator tells you that the DVD or CD-RW drive is being accessed. If the Auto Insert function is active, the indicator will flash periodically when your system is checking the DVD or CD-RW drive. If the Auto Insert Notification function is not active, the indicator will only flash when you access the DVD or CD-RW drive. The default setting is the Auto Insert Notification function active. (See *Auto Insert Notification Function on page 49 for more information*)

POINT

The Windows DVD/CD Auto Insert Notification function will periodically check for a DVD/CD installed in the drive, causing the Media Drive Access indicator to flash. The DVD/CD Auto Insert Notification function allows your system to automatically start a DVD/CD as soon as it is inserted in the drive and the tray is closed. It will begin playing an audio DVD/CD or will start an application if the DVD/CD has an auto-run file. (See *Auto Insert Notification Function on page 49 for more information*)

HARD DRIVE OR REMOVABLE MEDIA DRIVE ACCESS INDICATOR

The Hard Drive Access indicator states whether your internal hard drive or optional second hard drive is being accessed.

POINT

The Hard Drive Access indicator does not show which hard drive is being accessed.

FLOPPY DISK DRIVE ACCESS INDICATOR

The Floppy Disk Drive Access indicator states whether the floppy disk drive is being accessed. This indicator will flash if your software tries to access a disk even if no floppy disk drive is installed. (See *External USB Floppy Disk Drive on page 45 for more information*)

PC CARD ACCESS INDICATORS

The PC Card Access indicator(s) state whether or not your LifeBook notebook is accessing a PC Card(s). The indicator will flash if your software tries to access a PC Card even if there is no card installed. The number inside the indicator refers to which PC Card slot is being accessed. (See *PC Cards on page 51 for more information*)

NUMLK INDICATOR

The NumLk indicator states that the internal keyboard is set in ten-key numeric keypad mode. (See *Using the Keyboard on page 17 for more information*)

POINT

If you are using the optional external numerical keypad, pressing the [NumLk] key will activate the external keypad. The indicator will come on, however it will not change any of the functionality of your keyboard keys.



CAPSLock INDICATOR

The CapsLock indicator states that your keyboard is set to type in all capital letters. (See *Using the Keyboard on page 17 for more information*)



SCRlK INDICATOR

The ScrLk indicator states that your scroll lock is active. (See *Using the Keyboard on page 17 for more information*)



SECURITY INDICATOR

The Security Indicator flashes (if a password was set) when the system resumes from Off or Suspend modes. You must enter the password that was set in the Security Panel before your system will resume operation.

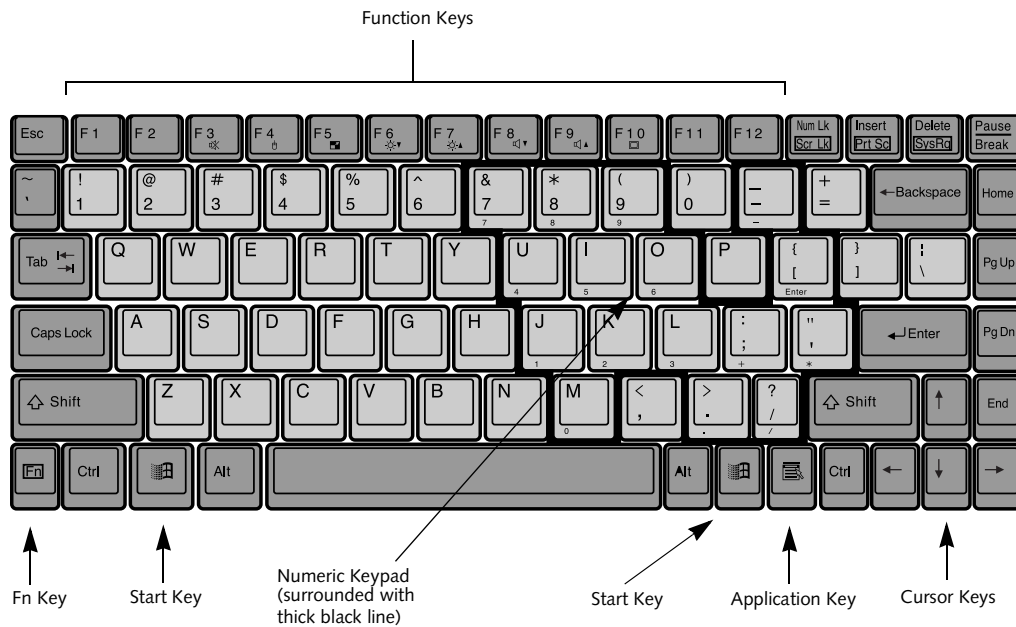

Figure 2-11 Keyboard

Keyboard

USING THE KEYBOARD

Your Fujitsu LifeBook notebook has an integral 87-key keyboard. The keys perform all the standard functions of a 101-key keyboard, including the Windows keys and other special function keys. This section describes the following keys.

- **Numeric keypad:** Your LifeBook notebook allows certain keys to serve dual purposes, both as standard characters and as numeric and mathematical keys. The ability to toggle between the standard character and numerical keys is controlled through the [NumLk] key.
- **Cursor keys:** Your keyboard contains four arrow keys for moving the cursor or insertion point to the right, left, up, or down within windows, applications and documents.
- **Function keys:** The keys labeled [F1] through [F12] are used in conjunction with the [Fn] key to produce special actions that vary depending on what program is running.
- **Windows keys:** These keys work with your Windows operating system and function the same as the onscreen Start menu button, or the right button on your pointing device.

NUMERIC KEYPAD

Certain keys on the keyboard perform dual functions as both standard character keys and numeric keypad keys. NumLk can be activated by pressing the [NumLk] keys. Turning off the NumLk feature is done the same way.

Once this feature is activated you can enter numerals 0 through 9, perform addition (+), subtraction (-), multiplication (*), or division (/), and enter decimal points (.) using the keys designated as ten-key function keys. The keys in the numeric keypad are marked on the front edge of the key to indicate their secondary functions.

POINT

If you are using the optional external numerical keypad, pressing the [NumLk] key will activate the external keypad. The indicator will come on, however it will not change any of the functionality of your keyboard keys.

WINDOWS KEYS

Your LifeBook notebook has three Windows keys: two Start keys and an Application key. The two Start keys display the Start menu. This button functions the same as your onscreen Start menu button. The Application key functions the same as your right mouse button and displays shortcut menus for the selected item. (Please refer to your Windows documentation for additional information regarding the Windows keys.)

CURSOR KEYS

The cursor keys are the four arrow keys on the keyboard which allow you to move the cursor up, down, left and right in applications. In programs such as Windows Explorer, it moves the "focus" (selects the next item up, down, left, or right).

FUNCTION KEYS

Your LifeBook notebook has 12 function keys, F1 through F12. The functions assigned to these keys differ for each application. You should refer to your software documentation to find out how these keys are used.

The [Fn] key provides extended functions for the notebook and is always used in conjunction with another key.

- [Fn+F3]: Pressing [F3] while holding [Fn] will toggle the Audio Mute on and off.
- [Fn+F4]: Pressing [F4] while holding [Fn] will toggle the touchpad on and off. (This function key combination only works if the BIOS setting for Advanced>Keyboard/Mouse Features>Internal Pointing Device is set to Manual Setting.)
- [Fn+F5]: Pressing [F5] while holding [Fn] allows you to toggle between video compensation and no compensation. (Video compensation controls spacing on the display. When it is enabled, displays with less than 1024 x 768 or 800 x 600 pixel resolution will still cover the entire screen.)
- [Fn+F6]: Pressing [F6] repeatedly while holding [Fn] will lower the brightness of your display.
- [Fn+F7]: Pressing [F7] repeatedly while holding [Fn] will increase the brightness of the display.
- [Fn+F8]: Pressing [F8] repeatedly while holding [Fn] will decrease the volume of your LifeBook notebook.
- [Fn+F9]: Pressing [F9] repeatedly while holding [Fn] will increase the volume of your LifeBook notebook.
- [Fn+F10]: Pressing [F10] while holding [Fn] allows you to change your selection of where to send your display video. Each time you press the combination of keys you will step to the next choice. The choices, in order, are: built-in display panel only, both built-in display panel and external monitor or external monitor only.

Wireless Infrared Mouse

This section contains information on using the optional Wireless Infrared (IR) Mouse with your LifeBook notebook.

PREPARING YOUR IR MOUSE FOR USE

To prepare your IR Mouse, you need to:

1. Activate the port in your notebook's BIOS.
2. Purchase and install two AAA batteries.
3. Turn the IR Mouse power switch to your preferred setting.

POINT

By activating the IR Mouse, your PS/2 port may not work. If you need to use the PS/2 port, you need to change your BIOS setting again.

To activate the IR Mouse Port in your BIOS

1. Power On or Restart your notebook.
2. Press [F2] as soon as the Fujitsu screen appears.
3. When you see the Phoenix[®] BIOS Setup Utility, press the right arrow key once to display the Advanced Menu.
4. Press the down arrow three times until **Keyboard/Mouse Features** is highlighted.
5. Press [Enter].
6. Once the Keyboard/Mouse Features Menu appears, press the down arrow three times until **Infrared Mouse** is highlighted.
7. Press the [Spacebar] once to enable the Infrared Mouse setting.
8. Press [F10], then [Enter] to save the changes, exit the BIOS, and restart your notebook.

Range of Operation

Your IR Mouse communicates with the IR Mouse port on your notebook, located at the bottom right-hand corner of your Display Panel. In order for your mouse to communicate effectively with your notebook, you will need to keep it within the area in which the signals from the mouse can be received by your notebook. This area is pie-shaped, with the tip at the front of the mouse, and the back approximately 1.5 feet from the port on the L setting and 3 feet on the H setting (optimal settings).

This area, and the effective distance at either the L or the H setting is subject to environment, type of use, and other factors, and will vary. (Figure 2-12)

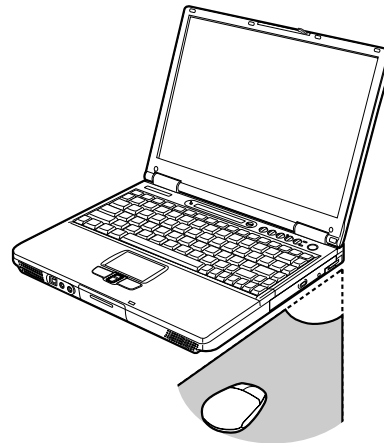

Figure 2-12. IR Mouse Area of Operation

To Install the Batteries

Turn your IR Mouse over, release the battery compartment cover by depressing the tab, remove the cover, and set it aside. Insert the batteries in the compartment, making sure that the “+” on the batteries corresponds with the “+” in the compartment. Replace the cover. (Figure 2-13)



Figure 2-13. IR Mouse Battery Installation

Power Switch and Settings

The power switch is located on the bottom of the mouse. Use your fingernail or the tip of a pen to slide it from the off position to either the L or the H setting. (Figure 2-14)

On the L setting, your mouse can communicate with the computer up to approximately 1.5 feet away. On the H setting it can communicate up to approximately 3 feet away. The H setting, however, depletes the mouse's batteries more quickly.

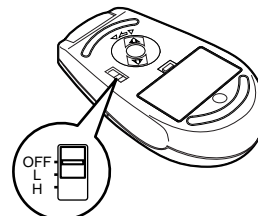

Figure 2-14. IR Mouse Power Switch

CAUTION

Be careful when using any other IR devices—such as TV remote controls—in the vicinity of your LifeBook notebook while using your IR Mouse. Your notebook could have difficulty distinguishing the signals.

Extending Battery Life

The life of the batteries in your IR Mouse is subject to many factors, including operating environment, types of use, and consistency of use.

To extend the life of the batteries:

1. Turn the IR Mouse off when not in use.
2. Use the L setting whenever possible.
3. Keep the IR Mouse port on your notebook and the IR port on the front of your mouse clean by wiping with a clean, dry, soft cloth.
4. Keep the ball and ball chamber clean.

Cleaning the Ball and Ball Chamber

In the bottom of your IR Mouse you will find a ring, with a ball underneath it. The ball, and the chamber in which it rolls, may require cleaning from time to time.

In order to clean the ball and chamber (*Figure 2-15*):

1. Turn the ring counter-clockwise until it stops. Lift the ring out, and set it aside.
2. Turn the mouse over, and let the ball fall into the palm of your other hand.
3. Clean the ball, the inside of the chamber, the rollers, and the back of the ring with a clean, dry, soft cloth.
4. Place the ball back into the chamber, replace the ring (being careful to set the ring flush against the back of the mouse), then turn the ring clockwise until it stops.

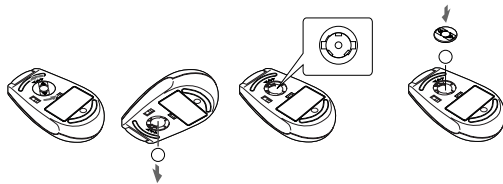

Figure 2-15. Cleaning the IR Mouse

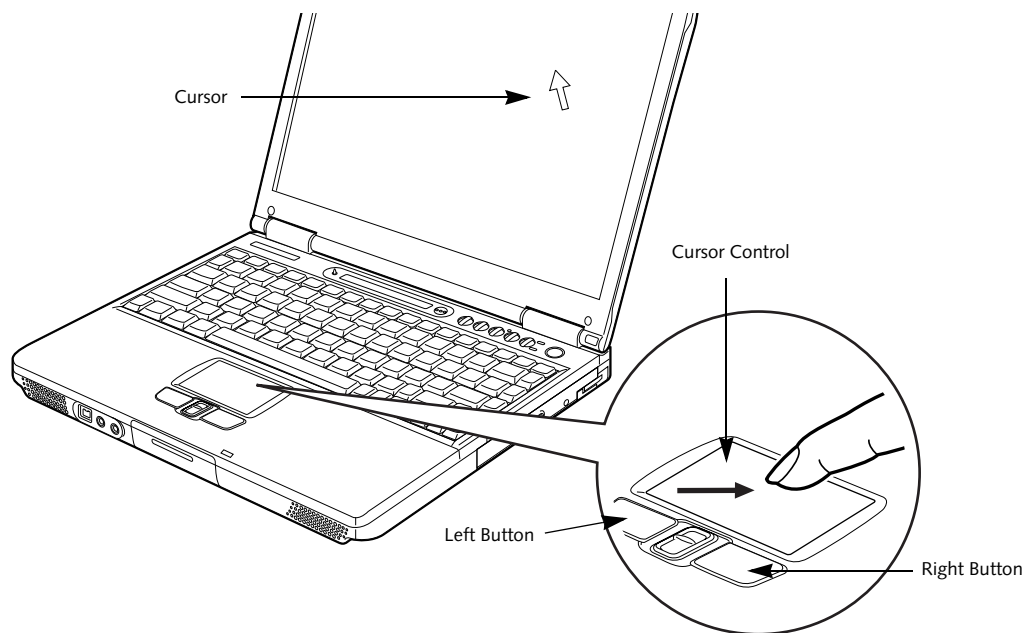

Figure 2-16. TouchPad pointing device

TouchPad Pointing Device

The TouchPad pointing device may come built into your Fujitsu LifeBook notebook. It is used to control the movement of the pointer to select items on your display panel. The TouchPad is composed of a cursor control and a left and right button. The cursor control works the same way a mouse does, and moves the cursor around the display. It only requires light pressure with the tip of your finger, and the more pressure you use, the faster the cursor will move. The left and right buttons function the same as mouse buttons. The actual functionality of the buttons may vary depending on the application that is being used. (Figure 2-16)

POINT

An external mouse can be connected to either the USB or PS/2 port on your LifeBook notebook, and be used simultaneously with the TouchPad. However, if you boot the system with an external mouse connected the TouchPad will be disabled or enabled depending on your BIOS settings. Also, if the Infrared Mouse is enabled, your PS/2 external device will be disabled. (See *BIOS Setup Utility* on page 35 for more information)

CLICKING

Clicking means pushing and releasing a button. To left-click, move the cursor to the item you wish to select, press the left button once, and then immediately release it. To right-click, move the mouse cursor to

the item you wish to select, press the right button once, and then immediately release it. You also have the option to perform the clicking operation by tapping lightly on the TouchPad once. (Figure 2-17)

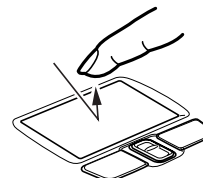

Figure 2-17. Clicking

DOUBLE-CLICKING

Double-clicking means pushing and releasing the left button twice in rapid succession. This procedure does not function with the right button. To double-click, move the cursor to the item you wish to select, press the left button twice, and then immediately release it. You also have the option to perform the double-click operation by tapping lightly on the TouchPad twice. (Figure 2-18)



Figure 2-18. Double-clicking

**POINT**

If the interval between clicks is too long, the double-click will not be executed.

TOUCHPAD CONTROL ADJUSTMENT

The Windows Control Panel allows you to customize your TouchPad with selections made from within the Mouse Properties dialog box.

DRAGGING

Dragging means pressing and holding the left button, while moving the cursor. To drag, move the cursor to the item you wish to move. Press and hold the left button while moving the item to its new location and then release it. Dragging can also be done using the TouchPad. First, tap the TouchPad twice over the item you wish to move making sure to leave your finger on the pad after the final tap. Next, move the object to its new location by moving your finger across the TouchPad, and then release your finger. (Figure 2-19)

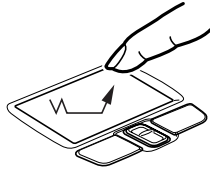

Figure 2-19. Dragging

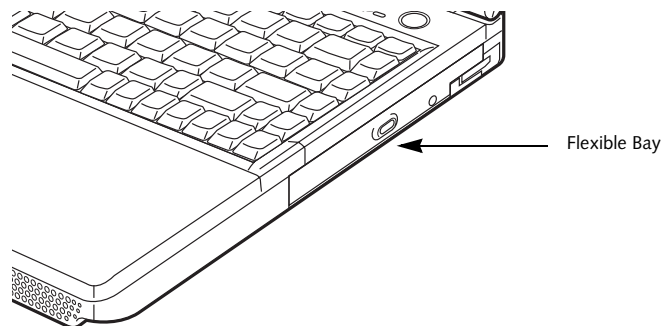

Figure 2-20 Flexible Bay

Flexible Bay Devices

Your LifeBook notebook contains a Flexible Bay. The Flexible Bay can accommodate a modular CD-ROM drive, DVD drive, DVD/CD-RW drive, Lithium ion battery, or weight saver. (Figure 2-20)

Your Flexible Bay will have one of the following devices installed. All devices listed here are also options which can be purchased separately. (Figure 2-21)

- Modular CD-ROM drive: This allows you to access software and audio CDs.
- Modular DVD drive: This allows you to access movies, software, and audio DVD/CDs.
- Modular DVD-CD-RW combo drive: This allows you to access movies, software, and audio DVD/CDs as well as to write to CDs.
- Modular Lithium ion battery: This is a rechargeable battery that can be used to power your LifeBook notebook when an adapter is not connected.
- Weight Saver: This is used to fill the bay when no device is needed.

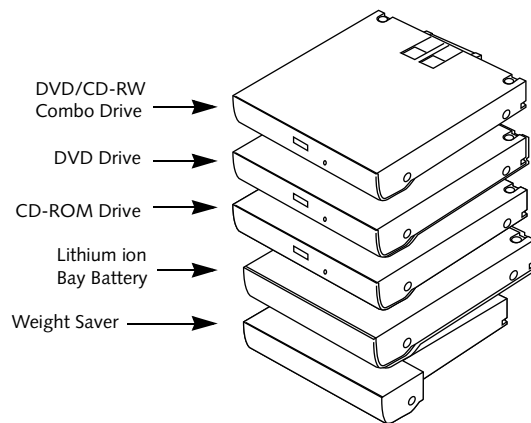

Figure 2-21 Flexible Bay Devices

POINT

You should never leave your Flexible Bay empty when the LifeBook notebook is in operation.

REMOVING AND INSTALLING MODULAR DEVICES

There are two ways to remove and install modular devices in the Flexible Bay:

- Cold-swapping: Swapping devices while your LifeBook notebook is powered off. (Reference the following section.)
- Hot-swapping: Swapping devices while your system is active using BayManager™ software. (Reference the sections of this chapter entitled "Hot-swapping with BayManager..." and "Hot-swapping under Windows 2000 Professional and Windows XP".)

Cold-swapping

To cold-swap modular devices in your Flexible Bay follow these easy steps: (Figure 2-22)

1. Close any open files.
2. Shut down your LifeBook notebook.
3. Pull out the Flexible Bay release latch, then press the latch in to release the modular device. This will push your device out slightly, allowing you to remove the device.
4. Slide your device out until it is clear of the bay. This will require light force.

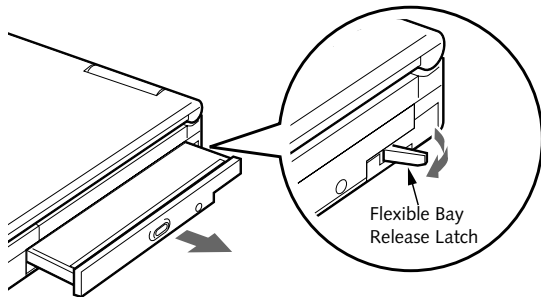

Figure 2-22 Removing a device from the Flexible Bay

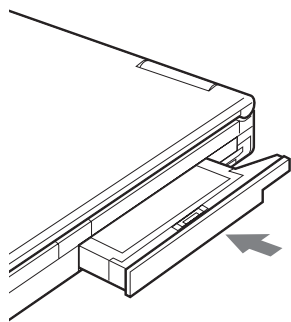

Figure 2-23 Installing a device in the Flexible Bay

CAUTION

Be careful when aligning and seating devices in the bay. If the fit is incorrect, you may damage the bay or the device. If the device does not move easily in the bay, remove it, and check for dirt or foreign objects. It will require a firm push to latch the device in place.

5. Slide the device you are installing into your LifeBook notebook until it clicks into place.
6. It is now safe to turn your notebook back on.
7. You can now access and use the device.

Your LifeBook notebook will automatically detect the new device and activate it within your system. The drive letters associated with the device will be created and listed under My Computer and Windows Explorer.

Hot-swapping with BayManager under Windows 98 Second Edition

BayManager provides a simple yet powerful method of switching modular devices on your LifeBook notebook without having to reboot. Windows 98 Second Edition does not natively support hot-swapping. With BayManager, you can swap modular devices while your OS is running, this is called hot-swapping.

POINT

BayManager does not support hot-swapping devices in Full Dock II device bay.

CAUTION

If you are swapping out a bay battery module, make sure that a charged main battery is installed or an AC Adapter is connected to the system. Failure to do so could result in data loss.

Using BayManager

It's easy to swap modular devices on your LifeBook notebook using BayManager.

Please wait for 30 seconds after Windows 98 Second Edition boots up or resuming from Standby/Hibernation before using the BayManager.

To hot-swap modular devices follow these easy steps:

1. Point your mouse on the BayManager icon on the Windows Taskbar (it looks like an open laptop computer).
2. Double-click the left mouse button to display the Softex BayManager Window.

POINT

A device is protected from being removed while the OS is using it. If the device is in use, an Error Message window pops up and requests you to close any open files. Close any open files and restart procedure at step 1.

3. Click **Remove/Swap** or **Insert** button to change a device in the Flexible Bay. A message appears telling you that it is safe to swap devices.
4. Swap the modular devices.
5. Click **OK** button.

After the "System Device Change" message disappears, you will be able to access and use the device.

Your LifeBook notebook will automatically detect the new device and activate it within your system. The drive letters associated with the device will be created and listed under My Computer and Windows Explorer.

Key information About BayManager

You can see the type of device present in the Flexible Bay by pointing to the BayManager icon on the taskbar or in Storage Devices tab of BayManager Properties.

The information about BayManager will appear as follows:

- Modular CD-RW/DVD drive:
Identified as *CD-ROM*.
- Modular floppy disk drive (FDD). FDD connected via specific connector on the connector box, or USB FDD:
Identified as *Floppy*.

Tips About Using BayManager

- If you have BayManager installed in your notebook, and want to enable Direct Memory Access (DMA) to a bay device, click the device icon on the Storage Devices tab of the BayManager dialogue box to check DMA. Please note that not all devices support DMA.
- Before running the software to swap or remove the current Flexible Bay device, be sure to close all open applications that could be using the current bay device.
- If you swapped or inserted your Flexible Bay device with My Computer or Windows Explorer opened, click View, and then click Refresh.
- After you swap or insert your Flexible Bay device, the DVD Autorun might stop. To work around this problem, double-click on My Computer, then double-click the icon for DVD drive.
- If a LifeBook notebook with an external USB FDD connected is put on Standby, the drive letter for the FDD might change (from A) after the computer is brought out of the power saving state. This phenomenon does not affect operations adversely.
- If Windows is started on a LifeBook notebook with an external USB FDD connected, an icon for the FDD might not appear in My Computer or Windows Explorer. If you encounter this problem, remove the FDD from your LifeBook notebook then reconnect it.
- If the FDD (A:) is not shown in My Computer or Windows Explorer even if the FDD is connected, execute [Insert] by using BayManager.

Hot-swapping under Windows 2000 Professional, XP Home, and XP Professional

Under Windows 2000 and XP, hot-swapping is provided through the Unplug or Eject Hardware utility. The icon for the utility appears on the taskbar. Refer to your Windows manual on using this feature.

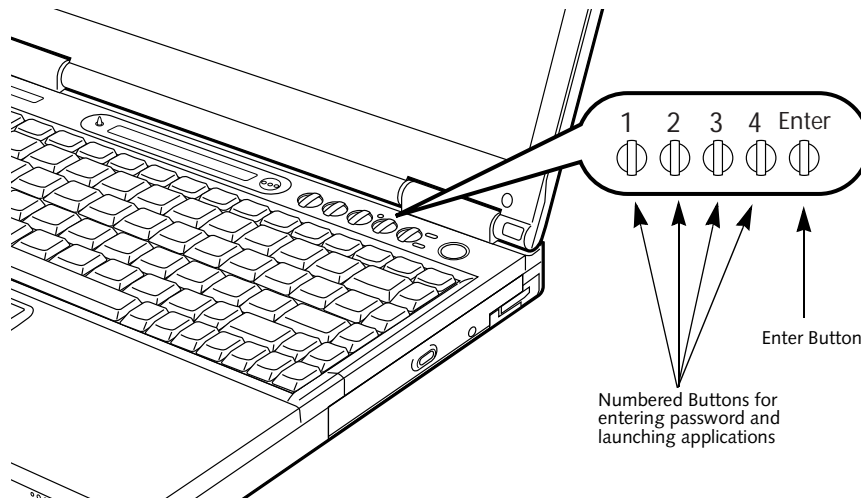

Figure 2-24 LifeBook Security/Application Panel

LifeBook Security/ Application Panel

A unique feature of your LifeBook notebook is the Security/Application Panel that allows you to secure your notebook from unauthorized use. The Security/Application Panel also allows you to launch applications with the touch of a button when your system is on.

If the security system is activated, upon starting your LifeBook notebook or resuming from suspend mode the security system requires you to enter a password code using the buttons on the Security/Application Panel. After entering a correct password, your LifeBook notebook resumes system operation. (Figure 2-24)

SETTING UP YOUR LIFEBOOK SECURITY PANEL

When you receive your LifeBook notebook, the security panel application is pre-installed without any passwords.

The following sections provide detailed information on your security panel, and how to set, change or remove passwords.

Numbered Buttons

Use these buttons to enter your password. (Figure 2-24)

Enter Button

After entering the button strokes, push this button to enter the password into the notebook. (Figure 2-24)

PASSWORDS

The user and supervisor password may be set on this LifeBook notebook. A supervisor password is typically the same for all notebooks in a working group, office, or company to allow for system management. Individual

notebooks in a group environment should not use a common password. A password consists of one to five button strokes plus the enter button. A valid stroke consists of pushing one or up to four buttons simultaneously. The following are valid button strokes:

- Pushing [4] by itself
- Pushing [2] and [3] at the same time
- Pushing [1], [2], and [4] at the same time
- Pushing [1], [2], [3], and [4] at the same time

The following are valid passwords. The numbers within braces ({ }) are button strokes using more than one button.

- {[2]+[3]}, [1], [enter]
- [4], [enter]
- {[1]+[3]}, {[2]+[3]+[4]}, [1], [4], [2], [enter]

Setting Passwords

When shipped from the factory, no passwords are set. You have a choice of having no password or setting a supervisor and user password. You must set the supervisor password before the user password.

POINTS

- The purpose of supervisor password is to be able to bypass the user password in case the user password is forgotten. The supervisor password alone will not lock the system.
- You have to set both the supervisor and user passwords for the security panel to work.

Setting Supervisor Password

You must have set a supervisor password before setting any user passwords. The supervisor password can bypass the user password.

1. Go to the **Start** menu.
2. Click on **Run**.
3. Type in
"C:\Program Files\Fujitsu\
Security Panel Application\
Supervisor\FJSECS.EXE" (be sure to use
the quotation marks), then press [Enter]
4. Follow the on-screen instructions to set the
Supervisor password.

Setting User Password

1. Go to the **Start** menu.
2. Click on **Programs**.
3. Click on **Security Panel Application > Security
Panel Application**.
4. Follow the on-screen instructions to set the
user password.

POINT

You may change or remove the supervisor or user password by repeating the steps defined above.

OPERATING YOUR LIFEBOOK SECURITY APPLICATION PANEL

The security lock feature is in effect both when the system resumes from OFF or suspend state. You always need to push the Suspend/Resume button to input the user password. Your system will not begin the boot sequence without entering your supervisor/user password.

From Off State

1. Turn on your system.
2. When the Security Indicator flashes, enter the password and press Enter button.
For example, if the password is 22222,
Press Button Number 2 five times and press Enter button.
The LifeBook notebook will boot to normal operation.

From Suspend State

1. Press your Suspend/Resume button.
2. When the Security Indicator flashes, enter the password and press Enter button.
The notebook should resume normal operation.

Incorrect Password Entry

If an invalid supervisor or user password is entered three times in succession, the system will "beep" for about one

minute. If a valid password is entered within a minute (while system beeps), the beeping will stop and the LifeBook notebook will resume normal operation. If no password or an invalid password is entered while the system beeps, the system will return to its previous locked state (suspend or off) and the Security Indicator will go off. To reactivate the LifeBook notebook after a password failure, you must press the Suspend/Resume button, then enter a correct password.

POINT

Remember the user password you specified on the Security Panel Application. If you forget the password you will not be able to use your computer. The supervisor password can override the user password.

PRECAUTIONS

Opening and Closing the Cover

Closing the cover may place the notebook into suspend mode. Opening the cover does not automatically place the notebook into normal operation. Instead, you must enter the proper security password after pushing the Suspend/Resume button.

Low Battery Operations

If your LifeBook notebook has a low battery, pushing the suspend/resume button only turns on the Security Indicator. Your notebook does not unlock, and the Security Indicator LED turns off after one minute. To resume normal operation, first attach a power supply to the LifeBook notebook. Then you may unlock the notebook.

UNINSTALLING THE SECURITY PANEL APPLICATION

You have two options when uninstalling the security panel application:

- Uninstall the security panel application software. This will disable all security feature.
- Uninstall the security panel application with password still active. This will not allow any changes to the password.

Uninstalling the Security Panel Application Software

Remove passwords when User wants no password protection whatsoever and doesn't want to give anybody the utility to set a password on their computer. In this case, if passwords (supervisor, user, or both) are set, the passwords must first be cleared BEFORE removing the application. To clear passwords, follow same procedure in SETTING PASSWORD CODES except this time, select REMOVE, enter current password then click Next. When asked to confirm select Yes.

Removing Security Panel Application with Passwords Still Active

Using this feature will not allow any changes to the password.



POINT

Removing the applications does not remove the password. It simply removes the utility to change/add/remove passwords. To change your password you must reinstall the application.

User:

1. Go to **Start Menu**, Click on **Control Panel**.
2. Open **Add/Remove Programs Properties** in the Control Panel.
3. Select the **Security Panel Application** in the list, and click **Add/Remove**.
4. When the **Confirm File Deletion** box appears, click **Yes**.

Supervisor:

1. Go to **Start Menu**, Click on **Control Panel**.
2. Open **Add/Remove Programs Properties** in the Control Panel.
3. Select the **Security Panel Application for Supervisor** in the list, and click **Add/Remove**.
4. When the **Confirm File Deletion** box appears, click **Yes**.

Reinstalling the Security Application Panel

To reinstall supervisor or user security application, you will need your Drivers and Applications Restore CD. The **Secpanel** folder located in the **Utilities\Security Panel** contains the setup files for supervisor and user security application.

1. Double-click the **Setup FJSECS.EXE** file. The **Installing Security Panel Application** window will appear. Follow the instructions on the screen.
2. Double-click the **Setup FJSECU.EXE** file. The **Installing Security Panel Application** window will appear. Follow the instructions on the screen.

Supervisor and user passwords can be set by the Windows Software which are FJSECS.EXE and FJSECU.EXE respectively. FJSECU.EXE for user password cannot run without supervisor password. First you need to run FJSECS.EXE to set supervisor password before setting user password. Follow instructions under **Setting Passwords** on page 26.

If you forget both passwords, contact Fujitsu Service and Support at 1-800-8Fujitsu (1-800-838-5487). Fujitsu charges a service fee for unlocking a password restricted LifeBook notebook. When calling please have a valid credit card and provide proof of ownership. You

will then be given instructions on where to ship your LifeBook notebook.

LAUNCHING APPLICATIONS WITH THE SECURITY/APPLICATION PANEL

The security panel also enables you to launch applications with the touch of a button when your system is on. Pressing any of the buttons will launch a user-defined application. Your LifeBook notebook is pre-installed with software utilities that let you operate and configure your LifeBook Security/Application Panel. These utilities are found under the Start menu, under Programs, then under LifeBook Application Panel. They include Application Panel Setup, Guide, Activate Panel and Deactivate Panel.

Configuring your LifeBook Application Panel

When you start Windows, the LifeBook Application Panel is automatically activated. An icon resembling a finger pressing a button will appear on the system tray (the indented portion of the status bar where the clock is displayed). When you see this icon you will know that LifeBook Application Panel is active.

As an application launcher, the LifeBook Application Panel is very flexible, giving you a variety of options. To set up the Panel to best suit your needs, we have provided the Application Panel Setup utility that quickly and easily helps you make the most of this valuable feature.

To configure your LifeBook Application Panel with Application Panel Setup:

1. Click on **Start**.
2. Click on **Programs**.
3. Click on **LifeBook Application Panel**.
4. Click on **Application Panel Setup**.

The Application Panel Setup utility will appear. There are tabs that correspond to the application buttons on the LifeBook Application Panel. When you receive your LifeBook notebook, these buttons are pre-configured to launch the associated programs, as defined in Chapter 7.



POINT

The tabs in Application Panel Setup may not be in the same order as the buttons on your LifeBook notebook, please select the tab you wish to change carefully.

To change an application associated with the Application buttons, click on the tab for the button you would like to reconfigure – for example, Application A. Click on **Browse** from Start Menu, scroll down the list of applications, click on the application you wish to launch with this button, and then click **OK**. The button will now launch the new application.

Getting to Know Your LifeBook

The Internet tab is different. It comes set to launch your Windows default Internet browser (Internet Explorer), unless you have changed this in Windows. In order to reconfigure it to launch another program follow these easy steps:

1. Click on **Other** from the Internet browser box.
2. Click on **Browse** from Start Menu.
3. Scroll down the list of applications, and then click on the application you wish to launch with this button.
4. Click **OK**.

The button will now launch the new application. If you want to return to launching your Windows default Internet browser with this button, you need only click on "Default Internet Browser" from the Internet browser box. Be aware that you will erase the settings for the "other application". If you wish to go back to launching the "other application" from this button, you will need to reconfigure it as described above.

 **POINT**

The Internet or E-mail buttons can be configured to launch any application you wish, not just an Internet browser or e-mail program.

When you have finished with Application Panel Setup click OK, and the new settings will take effect. You can reconfigure your LifeBook Application Panel as often as you like.

Deactivating and Activating the LifeBook Application Panel

To deactivate the LifeBook Application Panel, follow these easy steps:

1. Click on **Start**.
2. Click on **Programs**.
3. Click on **LifeBook Application Panel**.
4. Click on **Deactivate Panel**.

To reactivate, follow the same procedure, except for step 4. Click on **Activate Panel** instead.

 **POINT**

Every time you start Windows the LifeBook Application Panel is activated, even if you deactivated it before you shut down.



LifeBook E Series - Section 2

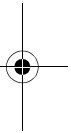
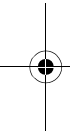

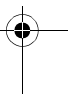
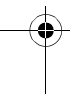

3

Getting Started

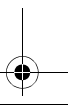
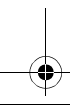
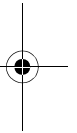
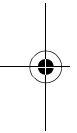

LifeBook E Series - Section 3

Getting Started

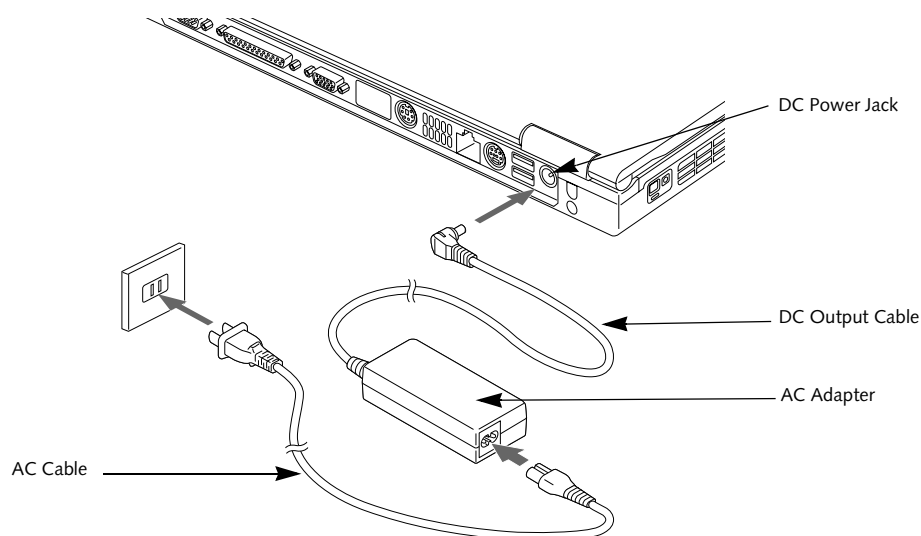

Figure 3-1 Connecting the AC Adapter

Power Sources

Your Fujitsu LifeBook notebook has four possible power sources: a primary Lithium ion battery, a secondary Lithium ion battery (for Flexible Bay installation), an AC adapter, or an optional Auto/Airline adapter.

CONNECTING THE POWER ADAPTERS

The AC adapter or optional Auto/Airline adapter provides power for operating your LifeBook notebook and charging the batteries.

Connecting the AC Adapter

1. Plug the DC output cable into the DC power jack of your LifeBook notebook.
2. Plug the AC adapter into an AC electrical outlet. (Figure 3-1)

Connecting the Optional Auto/Airline Adapter

1. Plug the DC output cable into the DC power jack on your LifeBook notebook.

2. Plug the Auto/Airline adapter into the cigarette lighter of an automobile with the ignition key in the On or Accessories position.

OR

3. Plug the Auto/Airline adapter into the DC power jack on an airplane seat.

Switching from AC Adapter Power or the Auto/Airline Adapter to Battery Power

1. Be sure that you have at least one charged battery installed.
2. Remove the AC adapter or the Auto/Airline adapter.

POINT

The Lithium ion battery is not charged upon purchase. Initially, you will need to connect either the AC adapter or the Auto/Airline adapter to use your LifeBook notebook.

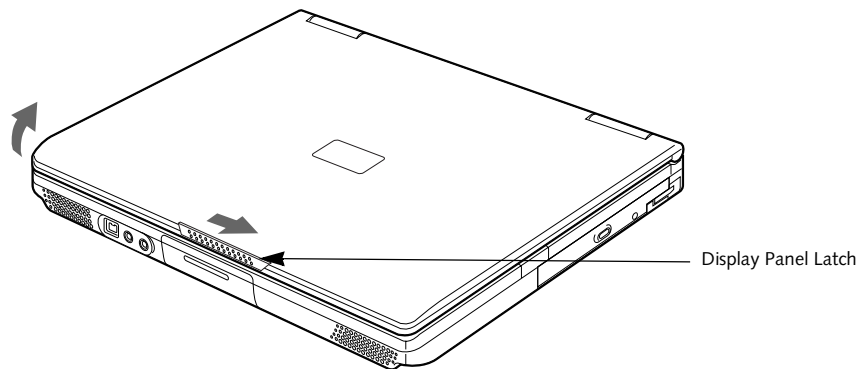

Figure 3-2 Opening the Display Panel

Display Panel

Your Fujitsu LifeBook notebook contains a display panel that is backlit for easier viewing in bright environments and maintains top resolution through the use of active-matrix technology.

OPENING THE DISPLAY PANEL

1. Slide the display panel latch to the right to release the locking mechanism.
2. Lift the display panel backwards, being careful not to touch the screen, until it is at a comfortable viewing angle.

ADJUSTING DISPLAY PANEL BRIGHTNESS

Once you have turned on your LifeBook notebook, you may want to adjust the brightness level of the screen to a more comfortable viewing level. There are two ways to adjust the brightness keyboard and power management utility

Keyboard

- [Fn+F6]: Pressing repeatedly will lower the brightness of your display.
- [Fn+F7]: Pressing repeatedly will increase the brightness of the display.

POINT

If using AC power, your LifeBook notebook's brightness setting is set to its highest level by default. If using battery power, the brightness setting is set to its middle level by default.

POINT

The higher the brightness level, the more power the LifeBook notebook will consume and the faster your batteries will discharge. For maximum battery life, set the brightness level as low as possible.

Using the BatteryAid Utility (Windows 98 and 2000 only)

Adjusting the brightness using the Power Management Utility changes the setting permanently.

1. Double-click the Battery Icon in the lower right corner of your display (it looks like a small battery with a leaf extending from the top). This will open the BatteryAid Properties dialog box.
2. Click on the Fujitsu BatteryAid 2/2 tab and adjust your LCD Backlighting to the desired level.
3. Click OK or Apply to permanently change the settings.

You may need to readjust the brightness level periodically depending on your operating environment.

CLOSING THE DISPLAY PANEL

1. Holding the edge of your display panel, pull it forward until it is flush with the body of your LifeBook notebook.
2. Push down until you hear a click. This will engage the locking mechanism and prevent your display panel from opening unexpectedly.

Starting Your LifeBook Notebook

POWER ON

Power and Suspend/Resume Button

The Power and Suspend/Resume button is used to power on your LifeBook notebook, to resume from Standby or Save-to-Disk mode, to place your notebook in Standby or Save-to-Disk mode or to power off. You can also turn off your notebook by choosing **Shut Down** from the Windows Start menu.

Once you have connected your AC adapter or charged the internal Lithium ion Battery, you can press this button to Power On your LifeBook notebook. (See *Figure 2-4 on page 8 for location*)

POINT

When you turn on your LifeBook notebook be sure you have a power source. This means that at least one battery is installed and charged, or that the AC or Auto/Airline adapter is connected and has power.

CAUTION

Do not carry your LifeBook notebook around with the power on or subject it to shocks or vibration, as you risk damaging your notebook.

When you Power On your notebook, it will perform a Power On Self Test (POST) to check the internal parts and configuration for correct functionality. If a fault is found, your notebook will emit an audio warning and/or an error message will be displayed. (See *Power On Self Test Messages on page 70 for more information*)

Depending on the nature of the problem, you may be able to continue by starting the operating system or by entering the BIOS setup utility and revising the settings.

After satisfactory completion of the Power On Self Test (POST), your LifeBook notebook will load your operating system.

POINT

Never turn off your LifeBook notebook during the Power On Self Test (POST) or it will cause an error message to be displayed when you turn your notebook on the next time. (See *Power On Self Test Messages on page 70 for more information*)

BOOT SEQUENCE

The procedure for starting-up your Fujitsu LifeBook notebook is termed the Bootup sequence and involves your notebook's BIOS. When your notebook is first turned on, the main system memory is empty, and it needs to find instructions to start up your notebook. This information is in the BIOS program. Each time you power up or restart your notebook, it goes through a boot sequence which displays a Fujitsu logo until your operating system is loaded. During booting, your notebook is performing a standard boot sequence including a Power On Self Test (POST). When the boot sequence is completed without a failure and without a request for the BIOS Setup Utility, the system displays the operating system's opening screen.

The boot sequence is executed when:

- You turn on the power to your LifeBook notebook.
- You restart your LifeBook notebook from the Windows Shut Down dialog box.
- The software initiates a system restart. Example: When you install a new application.
- You reset the system by pressing the three keys [CTRL+ALT+DEL].

BIOS SETUP UTILITY

The BIOS Setup Utility is a program that sets up the operating environment for your LifeBook notebook. Your BIOS is set at the factory for normal operating conditions, therefore there is no need to set or change the BIOS' environment to operate your LifeBook notebook.

The BIOS Setup Utility configures:

- Device control feature parameters, such as changing I/O addresses and boot devices.
- System Data Security feature parameters, such as passwords.

Entering the BIOS Setup Utility

To enter the BIOS Setup Utility do the following:

1. Turn on or restart your LifeBook notebook.
2. Press the [F2] key once the Fujitsu logo appears on the screen. This will open the main menu of the BIOS Setup Utility with the current settings displayed.
3. Press the [RIGHT ARROW] or [LEFT ARROW] key to scroll through the other setup menus to review or alter the current settings. Additional navigational information is located at the bottom of the BIOS screen.

BIOS Guide

A guide to your LifeBook notebook's BIOS is available online. Please visit our service and support Web site at www.fujitsupc.com/support. Once there, select Support, then select Notebooks under User's Guides. Select LifeBook BIOS Guides from the pull-down menu for your LifeBook series. If you are unsure of your notebook's BIOS number, refer to your packing slip.

POINT

If your data security settings require it, you may be asked for a password before the BIOS main menu will appear.

BOOTING THE SYSTEM

We strongly recommend that you do not attach any external devices and do not put a CD or floppy disk in any drive until you have gone through the initial power on sequence.

When you turn on your LifeBook notebook for the first time, it will display a Fujitsu logo on the screen. If you do nothing, the system will load the operating system, and then the Windows Welcome will begin.

Designed to accommodate the needs of users in many different countries, Windows needs to be configured the first time you use it. Windows has three parts:

- **Getting Started:** You have the opportunity to enter custom information for your configuration file and setup your modem so that your LifeBook notebook will be prepared to dial out.
- **Registration:** Easy online registration for Windows with Microsoft, and for your LifeBook notebook with Fujitsu.
- **Windows License Agreement and Final Settings:** You have the opportunity to review the Windows.

POINT

If you reject the terms of the license agreement you will be asked to review the license agreement for information on returning Windows 2000 Professional or to shut down your LifeBook notebook.

Getting Started

Read the instructions on the screens carefully and fill in the information as directed. You will be asked for such items as the language you wish to use, the country in which you live, your first and last name, and about how you dial out from where you will be using your notebook. For the modem settings, enter your current location information where you will be using your LifeBook notebook. If you are not connected to a phone

line and plan to register at a later time, you may click the **Skip** button, and you will go directly to the condition of use page.

Once you have set up your notebook to dial out, Windows will make a free telephone call which will test these settings. If the call is unsuccessful, you will be returned to the phone settings page where you may try to fix them. If you are unable to fix the settings please contact Fujitsu Service and Support. (*See Fujitsu Contact Information on page 3 for more information*).

If you would simply like to move on, and register at a later time, you may click the **Skip** button, and you will go directly to the Condition of Use page.

Registration

If your connection is successful, you will go to the Registration Confirmation page. On this page simply enter the requested information, and then check the box at the bottom to register your copy of Windows with Microsoft. Once you have finished, click the **Next** button to continue.

POINT

If you do not register at this time you can do it later simply by double-clicking on the **LifeBook Registration** icon on your desktop and following the instructions.

You will then go through the Fujitsu registration process. Follow the instructions on the screens, and enter all of the necessary information. Be as specific as possible so that if you need help the service and support team will be able to serve you better.

Final Settings

The first part of your final settings is the Windows End User License Agreement. Read the agreement carefully. When you finish reading you must accept or reject the terms of the agreement and then click on the **Next** button.

POINT

If you reject the terms of the license agreement you will be asked to review the license agreement for information on returning to Windows or to shut down your LifeBook notebook.

WINDOWS PRODUCT ACTIVATION (WINDOWS XP ONLY)

If your system has Windows XP as an operating system, it has already been pre-installed and pre-activated when you receive the system.

In the event you need to re-install Windows XP (e.g., after making significant configuration changes), it may

be necessary to reactivate the operating system. To do so, use the following information.

- After re-installing Windows XP, you have thirty days to activate it. Product activation ensures that you are the only authorized user of this copy of Windows.
- Until you activate the product, you will be prompted whenever you turn on the system that activation is required. Follow the on-screen directions to activate your operating system. The product only needs to be activated once, unless significant hardware changes are made to your system.
- Note that Product Activation and Registration are not the same thing. Registration is optional, whereas Product Activation is a required procedure.

REGISTERING YOUR LIFEBOOK NOTEBOOK

What are the benefits of registering?

You will receive an identification label for your LifeBook notebook, which, if your notebook is ever lost, may help in getting it returned to you. You also receive technical support access and useful product mailings. Proof of purchase is not required if you register within 30 days of your purchase.

How do I register?

With Windows, it is a part of the Windows Welcome process. If you do not register during the Welcome process you can double-click on the LifeBook Registration icon on your desktop and then follow the instructions. The LifeBook Registration icon is the only way to register Windows 2000 Professional.

POINT

Make sure you have connected a phone line to your modem before you use E-Registration.

You may also complete the pre-printed registration form and either:

- Fax to 1-800-577-9989
- Mail to:
Fujitsu PC Corporation
750 139th Ave.
San Leandro, CA 94578

You may also register on our Web site:

- www.fujitsupc.com/support.
- You will need to be set up with an Internet Service Provider (ISP) to use this option.

INSTALLING CLICK ME!

The first time you boot up your system, you will see an icon called Click Me! (The icon is located on the desktop for Windows 98 and in the Start menu for Windows XP systems). When you click the Click Me! icon, your system will automatically build the icon tray in the bottom right of the screen. These icons provide links to utilities that you will frequently access.

The icon is automatically deleted after you launch Click Me! and restart the system.

Power Management

Your LifeBook notebook has many options and features for conserving battery power. Some of these features are automatic and need no user intervention, such as those for the internal modem. However, others depend on the parameters you set to best suit your operating conditions, such as those for the display brightness. Internal power management for your LifeBook notebook may be controlled from settings made in your operating system or from settings made in the BIOS setup utility.

Besides the options available for conserving battery power, there are also some things that you can do to prevent your battery from running down as quickly. For example, you can create an appropriate power saving profile, put your notebook into Suspend mode when it is not performing an operation, and you can limit the use of high power devices. As with all mobile, battery powered computers, there is a trade-off between performance and power savings.

POWER AND SUSPEND/RESUME BUTTON

When your LifeBook notebook is active, the Power and Suspend/Resume button can be used to manually put your notebook into Suspend mode. Push the Power and Suspend/Resume button when your notebook is active, but not actively accessing anything, and immediately release the button. You will hear two short beeps and your system will enter Suspend mode.

If your notebook is suspended, pushing the Power and Suspend/Resume button will return your notebook to active operation. You can tell whether or not your system is in Suspend mode by looking at the Power indicator. (See *Figure 2-9 on page 14 for location*) If the indicator is visible and not flashing, your LifeBook notebook is fully operational. If the indicator is both visible and flashing, your notebook is in Suspend mode. If the indicator is not visible at all, the power is off or your notebook is in Save-to-Disk mode. (See *Save-to-Disk Mode*)

SUSPEND MODE

Suspend or Standby mode in Windows 98 Second Edition or Windows 2000 Professional saves the contents of your LifeBook notebook's system memory during periods of inactivity by maintaining power to critical parts. This mode will turn off the CPU, the display, the hard drive, and all of the other internal components except those necessary to maintain system memory and allow for restarting. Your LifeBook notebook can be put in Suspend mode by:

- Pressing the Power/Suspend/Resume button when your system is turned on.
- Selecting Standby from the Windows Shut Down menu.

- Timing out from lack of activity.
- Allowing the battery to reach the Dead Battery Warning condition.

Your LifeBook notebook's system memory typically stores the file(s) on which you are working, open application(s) information, and any other data required to support the operation(s) in progress. When you resume operation from Suspend mode, your LifeBook notebook will return to the point where it left off. You must use the Power and Suspend/Resume button to resume operation, and there must be an adequate power source available, or your LifeBook notebook will not resume.



POINTS

- If you are running your LifeBook notebook on battery power, be aware that the battery continues to discharge while your LifeBook notebook is in Suspend mode, though not as fast as when fully operational.
- Disabling the Suspend/Resume button prevents it from being used to put your LifeBook notebook in Suspend or Save-to-Disk mode. The resume function of the button cannot be disabled.
- The Suspend or Hibernation (Save-to-Disk) mode should not be used with certain PC Cards. Check your PC Card documentation for more information.
- When PC Cards or external devices are in use, Hibernation (Save-to-Disk) mode cannot return to the exact state prior to suspension because all of the peripheral devices will be re-initialized when the system re-starts.
- If your LifeBook notebook is actively accessing information when you enter the Suspend or Hibernation (Save-to-Disk) mode, changes to open files are not lost. The files are left open and memory is kept active during Suspend mode, or the memory is transferred to the internal hard drive during Hibernation mode.
- The main advantage of using the Hibernation (Save-to-Disk) function is that power is not required to maintain your data. This is particularly important if you will be leaving your LifeBook notebook in a suspended state for a prolonged period of time. The drawback of using Hibernation mode is that it lengthens the power down and power up sequences and resets peripheral devices.

 **POINT**

Save-to-Disk mode requires allocating a significant amount of hard drive capacity for saving all system memory, which reduces your usable disk space. When you purchase your LifeBook notebook it will have space allocated for the memory installed. If you upgrade the original system by adding a memory upgrade module without changing the size of your Save-to-Disk allocation you will get an error message when you try to activate Save-to-Disk mode and it will not work. Use the PHDISK Utility (Windows 98 only) to increase the size of the Save-to-Disk file, SAVE2DSK.BIN. You can download the Save-to-Disk File Allocation information from our Web site at www.8fujitsu.com. If you need help, contact your support representative for recommendations.

HIBERNATION (SAVE-TO-DISK) FEATURE

The Hibernation feature saves the contents of your LifeBook notebook's system memory to the hard drive as a part of the Suspend/Resume mode. You can enable or disable this feature.

Enabling or Disabling the Hibernation Feature

The default setting is not enabled. To enable or disable the Hibernation feature follow these easy steps:

1. From the **Start** menu, select **Settings**, and then select **Control Panel**.
2. From the **Control Panel**, select **Power Management**.
3. Select **Hibernation** tab. Select the box to enable or disable this feature.

Using the Hibernation Feature

1. From the **Start** menu, select **Settings**, and then select **Control Panel**.
2. From the **Control Panel**, select **Power Management** -> **Power Options**.
3. Select **Advanced** tab, then select **Hibernate** from the pull-down menu for Power buttons.

DISPLAY TIMEOUT

The Video Timeout is one of the power management parameters. This feature saves power by turning off the display if there is no keyboard or pointer activity for the user selected timeout period. Any keyboard or pointer activity will cause the display to restart automatically. This feature is independent of the Power and Suspend/Resume button and can be enabled and disabled in Windows and BIOS setup utility. (See *BIOS Setup Utility* on page 35 for more information)

HARD DISK TIMEOUT

The Hard Disk Timeout is another one of the power management parameters. This feature saves power by

turning off the hard drive if there is no hard drive activity for the user selected timeout period. Any attempt to access the hard drive will cause it to restart automatically. This feature is independent of the Power and Suspend/Resume button and can be enabled and disabled in Windows and BIOS setup utility. (See *BIOS Setup Utility* on page 35 for more information)

WINDOWS 98 SECOND EDITION POWER MANAGEMENT**Power Management**

The Power Management icon located in the Windows 98 Second Edition Control Panel allows you to configure some of the power management settings. For example, you can use the Power Management to set the timeout values for turning off the display and hard disks whether you are running the LifeBook notebook on battery power or one of the adapters.

ACPI and Windows 98 Second Edition

Short for Advanced Configuration & Power Interface, a power management specification developed by Intel, Microsoft, and Toshiba. ACPI, which is part of the Windows 98 Second Edition operating system, enables the operating system to control the amount of power given to each device attached to the computer. With ACPI, the operating system can turn off peripheral devices, such as the CD-ROM player, when it is not in use. Your operating system has been pre-configured for ACPI power management.

RESTARTING THE SYSTEM

If your system is on and you need to restart it, be sure that you use the following procedure.

1. Click the **Start** button, and then click **Shut Down**.
2. Select the **Restart** option from within the Windows Shut Down dialog box.
3. Click **OK** to restart your LifeBook notebook. Your notebook will shut down and then reboot.



POINT

Turning off your LifeBook notebook without exiting Windows or turning on your notebook within 10 seconds of the notebook being shut off may cause an error when you start the next time.



CAUTION

Never turn your LifeBook notebook off while an application is running. Be sure to close all files, exit all applications, and shut down your operating system prior to turning off the power with the power switch. If files are open when you turn the power off, you will lose any changes that have not been saved, and may cause disk errors.

POWER OFF

Before turning off the power by choosing Shut Down from the Windows 98 Second Edition or Windows 2000 Professional Start menu, check that the Hard Drive, DVD, CD-ROM, CD-RW, PC Card and the Floppy Disk Drive Access indicators are all Off. (See *Figure 2-9 on page 14*) If you turn off the power while accessing a disk or PC Card there is a risk of data loss. To assure that your LifeBook notebook shuts down without error, use the Windows shut down procedure.

Using the correct procedure to shut down from Windows allows your LifeBook notebook to complete its operations and turn off power in the proper sequence to avoid errors. The proper sequence is:

1. Click the **Start** button, and then click **Shut Down**.
2. Select the **Shut Down** option from within the Windows Shut Down dialog box.
3. Click **OK** to shutdown your LifeBook notebook.

If you are going to store your notebook for a month or more see Care and Maintenance Section.

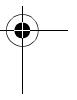
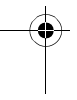

4

User-Installable Features

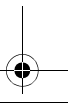
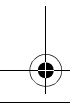
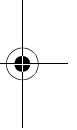
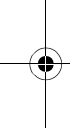

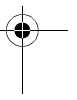
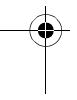

LifeBook E Series - Section 4

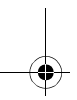
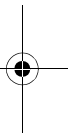
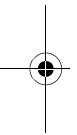

Lithium ion Battery

Your Fujitsu LifeBook notebook has a Lithium ion battery that provides power for operating your notebook when no external power source is available. The rechargeable battery is durable and long lasting, but should not be exposed to extreme temperatures, high voltages, chemicals or other hazards.

The Lithium ion battery operating time may become shorter if it is used under the following conditions:

- When used at temperatures that exceed a low of 5°C (40°F) or a high of 35°C (95°F). Extreme temperatures not only reduce charging efficiency, but can also cause battery deterioration. The charging icon on the Status Indicator panel will flash when you try to charge a battery that is outside its operating temperature range. (See *Battery Charging Indicators* on page 15 for more information)
- When using a high current device such as a modem, DVD drive, CD-RW drive, or the hard drive, using the AC adapter will conserve your battery life.

CAUTION

- Do not leave a faulty battery in your LifeBook notebook. It may damage your AC adapter, optional Auto/Airline adapter, another battery or your notebook itself. It may also prevent operation of your notebook by draining all available current into the bad battery.
- Under federal, state, or local law it may be illegal to dispose of batteries by putting them in the trash. Please take care of our environment and dispose of batteries properly. Check with your local government authority for details regarding recycling or disposing of old batteries. If you cannot find this information elsewhere, contact your support representative at 1-800-8FUJITSU (1-800-838-5487).

POINT

Actual battery life will vary based on screen brightness, applications, features, power management settings, battery condition and other customer preferences. DVD, CD-RW drive, or hard drive usage may also have a significant impact on battery life. The battery charging capacity is reduced as the battery ages. If your battery is running low quickly, you should replace it with a new one.

RECHARGING THE BATTERIES

If you want to know the condition of the primary Lithium ion battery, check the Battery Level indicator located on the Status Indicator panel. The indicator changes as the battery level changes.

The Lithium ion battery is recharged internally using the AC adapter or Auto/Airline adapter. To recharge the battery make sure the battery that needs to be charged is installed in your LifeBook notebook and connect the AC or Auto/Airline adapter.

POINT

Make sure that the Battery Charging indicator and the percentage charge is shown inside the Battery Level icon on the Status Indicator Panel.

There is no memory effect on the Lithium ion battery therefore you do not need to discharge the battery completely before recharging. The charge times will be significantly longer if your LifeBook notebook is in use while the battery is charging. If you want to charge the battery more quickly, put your LifeBook into Suspend mode, or turn it off while the adapter is charging the battery. (See *Power Management* on page 38 for more information on Suspend mode and shutdown procedure)

POINT

Using heavy current devices such as a Modem or frequent DVD or CD-RW accesses may prevent complete charging.

Low Battery State

When the battery is running low, a low battery notification message will appear. If you do not respond to the low battery message, the batteries will continue to discharge until they are too low to operate. When this happens, your LifeBook notebook will go into Suspend mode. There is no guarantee that your data will not be lost once the notebook reaches this point.

CAUTION

To prevent loss of data, you should save all your active data and put your LifeBook notebook into Suspend mode when the low battery message first appears, until you can provide a new power source. You should provide power to your notebook from a charged battery, an AC power adapter, or Auto/Airline as soon as possible.

CAUTION

When you are in Suspend mode there must always be at least one power source active. If you turn off the power with the power switch, or remove all power sources while your LifeBook notebook is in Suspend mode, any data that has not been saved to the hard drive will be lost.

Dead Battery Suspend mode shows on the Status indicator just like the normal Suspend mode. Once your LifeBook notebook goes into Dead Battery Suspend mode you will be unable to resume operation until you provide a source of power either from an adapter, or a charged battery. Once you have provided power, you will need to press the Suspend/Resume button to resume operation. In the Dead Battery Suspend mode, your data can be maintained for some time, but if a power source is not provided promptly, the Power indicator will stop flashing and go out, meaning that you have lost the data that was not stored. Once you provide power, you can continue to use your LifeBook notebook while an adapter is charging the battery.

Shorted Batteries

The Status Indicator panel uses a symbol inside the battery outline of the Battery Level indicator to display the operating level available in that battery.

(See *Figure 2-10 on page 15*) If this display shows a Shorted Battery, it means that the battery is damaged and must be replaced so it does not damage any other parts of your LifeBook notebook.

REPLACING THE BATTERY

With the purchase of an additional battery, you can have a fully charged spare to swap with one that is not charged.

Follow the steps below to replace a battery (*Figure 4-1*):

1. Have a charged battery ready to install.
2. Shut down your notebook and disconnect the AC adapter.
3. Press the battery release latches toward the battery.
4. Lift the battery by the latch end and remove it from the bay.
5. Slide a charged battery into the bay and press it down until the latches click into place.
6. Plug in the AC adapter and turn the power on.

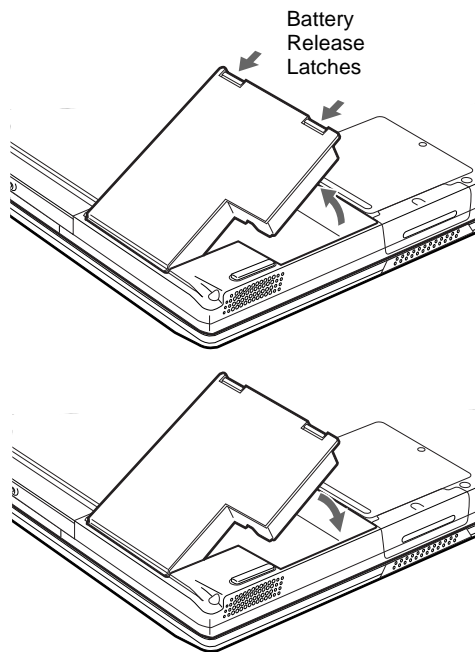

Figure 4-1 Replacing the Battery

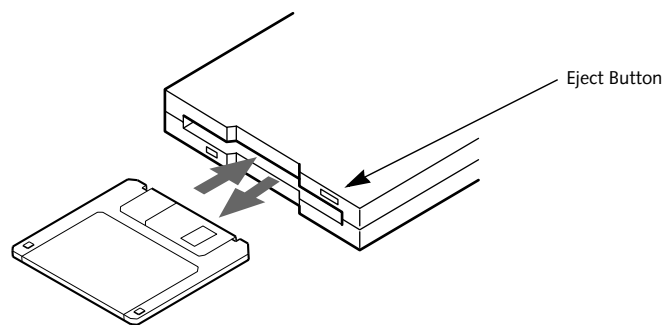

Figure 4-2 Loading/Ejecting a 3.5" Floppy Disk

External USB Floppy Disk Drive

Your LifeBook notebook has an external USB floppy disk drive which can read and write information on removable 1.44MB and 720KB floppy disks.

POINT

Your LifeBook notebook is preconfigured to boot from a USB floppy drive. Reference the BIOS manual for further information on changing the default boot drive. The BIOS manual can be found on the Fujitsu PC web site: www.FujitsuPC.com, under Support.

LOADING A DISK

To load a disk into your disk drive, follow these easy steps:

1. Orient the disk so that its label is facing upwards and the shutter side is pointing towards the drive. (Figure 4-2)
2. Push the disk into the drive until the Eject button pops out and you hear a click.

POINT

When there is no disk in the drive, the Eject button is flush with your notebook.

EJECTING A DISK

To eject a disk from the disk drive, follow these easy steps:

1. Check that the Floppy Disk Drive Access indicator is inactive.
2. Press the Eject button. This will push your disk partially out of the drive.
3. Remove the disk.

CAUTION

If you eject the disk while the Floppy Disk Drive Access indicator is active, there is a risk of damaging the data on the disk, the disk itself or even the disk drive.

PREPARING A DISK FOR USE

Before you can use a new disk, it needs to be prepared so your LifeBook notebook knows where to store information. This preparation is called formatting or initializing a disk. You will need to format new disks, unless they are preformatted. (*Please refer to your operating system manual for step-by-step instructions on formatting a disk*)

To prevent accidental erasure of the data stored on a disk, slide the "write protect" tab until a small hole is exposed. This sets the disk into a protected state where nothing can be added or removed. If you want to add or remove data on a protected disk, slide the "write protect" tab to close the small hole. (Figure 4-3)

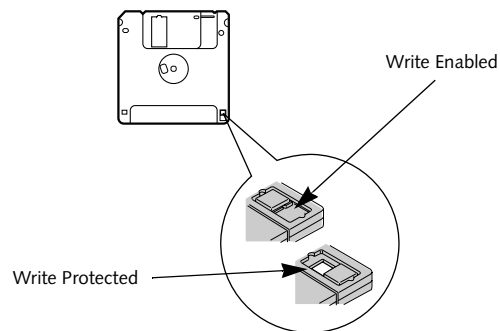

Figure 4-3 Floppy Disk Write Protect

CAUTION

Formatting a floppy disk that already contains data will erase all of the information on the disk.

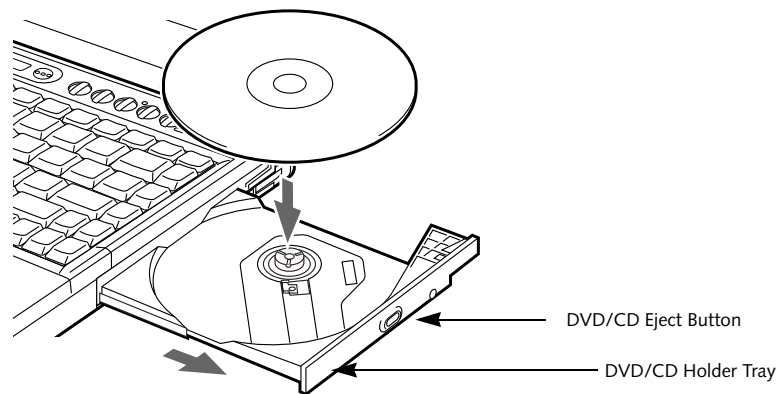

Figure 4-4. Media Player Drive

Media Drive

Your Fujitsu LifeBook notebook contains a media player drive which is either a CD, DVD, or DVD/CD-RW combo player. A DVD player gives you access to movie, software, and audio DVD/CDs. A DVD/CD-RW player allows you to write data onto recordable CDs in addition to all of the standard DVD drive functions.

MEDIA PLAYER SOFTWARE

DVD model only: With the media player drive and media player software you can play DVD movies on your LifeBook notebook. The media player includes controls which allow you to take full advantage of the features of a DVD movie, as well as standard features such as fast forward, fast reverse, pause, etc.

DVD/CD-RW Combo model only: With the combo drive, you can play DVD movies, read audio CDs, and write data onto recordable CD-R or CD-RW discs.



POINTS

- **Prior to using your Media Player, you must install the Media Player software.** Refer to the applicable readme file on the Driver Applications CD-ROM for instructions on installing your Media Player software.
- You should periodically check the Fujitsu Web site at www.fujitsupc.com for current updated drivers.



CAUTION

Do not operate your media player drive unless your LifeBook notebook is sitting on a flat surface. Using a drive when the system is not level may damage the drive or prevent proper operation.



POINT

Prolonged use of the media player drive, such as watching a DVD movie, will substantially reduce your battery life.

LOADING A DVD, CD, CD-R, CD-RW, OR COMBO ("MEDIA")

To load a disc into your media player drive, follow these steps:

1. Push and release the eject button on the front of the media player drive to open the holder tray. The tray will come out of the notebook a short distance.
2. Gently pull the tray out until a media disc can easily be placed in the tray.



CAUTION

There may be a protective sheet in the tray from when it was shipped; please make sure it is removed before operating the drive, otherwise your drive may be damaged.

3. Place the media into the tray, label side up, with the hole in the center of the disc. Snap the disc onto the raised circle in the center of the tray.
4. Gently push the holder tray back in until you hear a click. (Figure 4-5)



POINT

If you have disabled the Auto Insert Notification Function, you will have to start the drive from your desktop, since your notebook will not automatically recognize that media has been loaded.

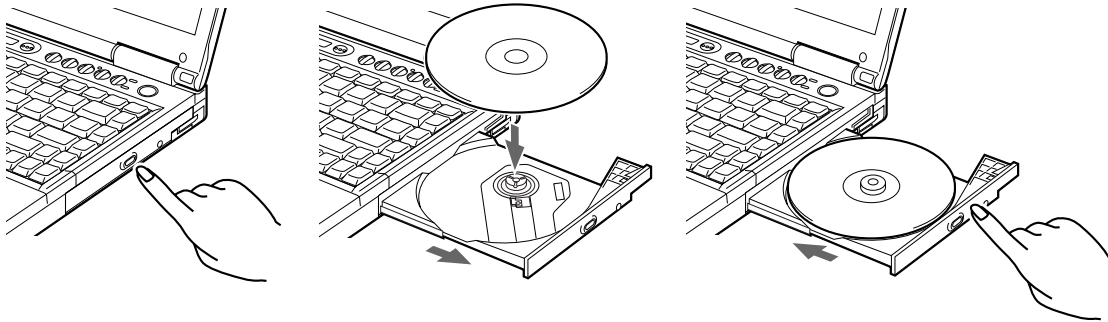

Figure 4-5 Loading/Ejecting Media

REMOVING MEDIA

1. Push and release the eject button on the front of the media player drive. This will stop the drive and the holder tray will come out of the notebook a short distance.
2. Gently pull the tray out until the disc can easily be removed from the tray.
3. Carefully remove the media disc from the holder tray.
4. Gently push the holder tray back in until you hear a click.

EMERGENCY DVD/CD-ROM TRAY RELEASE

If for some reason the eject button fails, you can open the DVD/CD-ROM tray with a paper clip or your pen inserted into the eject hole in the far right side of the front of the tray. Straighten one side of a paper clip and push it gently into the hole. The tray will pop out a short distance.

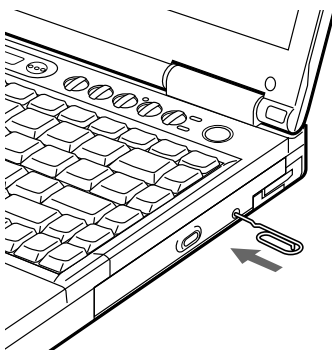

Figure 4-6 Emergency Removal of a CD/DVD

USING THE MEDIA PLAYER SOFTWARE

POINTS

- Prior to using your Media Player, you must install the Media Player software.
- For details on using your media player, consult the Help file that accompanies the software.

Starting a DVD Movie (DVD Models only)

1. Insert the DVD movie into the media player drive of your notebook. If the CD AutoRun feature activates, skip Step 2.
- 2a. *Windows 98 and 2000 only:* From the Start menu, select **Programs**, then select **InterVideo WINDVD** and click **InterVideo WINDVD** or double-click on the **InterVideo WINDVD** icon on the desktop. This will launch the DVD movie.
- 2b. *Windows XP only:* The first time you insert a movie into the DVD/CD-RW tray, you will be prompted to select what you want the system to do when discs are inserted (e.g., start automatically or wait for a prompt). Until you make a selection, you will receive the same prompt whenever you insert a disc.
3. Click **OK** to close the About DVD Player Performance dialog box and the movie will begin.

Opening the DVD/CD-RW Drive Control Panel

With most DVD-ROMs, you have the option of altering how the movie should play and what you wish to view. You can do this by using the DVD/CD-RW Combo Drive control panel and the mouse.

1. Right-click on the movie screen to open a dropdown menu for options.
2. Select **View**, then **Player** for all the controls available. This will open the control panel into the bottom of the screen.

Using the Media Player Control Panel

The Media Player software allows you to watch the movie much like a VCR player. You have the option to pause, rewind, fast-forward and stop the movie at any point.

1. To Pause the movie, click the **||** button.
2. To Rewind the movie, click the **◀** button to rewind to a specific portion of the movie, or the **◀◀** button to return to the opening screen.
3. To Fast-forward the movie, click the **▶▶** button to forward to a specific portion of the movie, or the **▶** button to jump to the ending credits.
4. To Stop the movie, click the **■** button.

Exiting the Media Player

1. Click on the **X** located in the upper right corner of the title bar. This will open a Media Player dialog box.
2. Click **Yes** to stop and exit the movie, or **No** to close the Media Player dialog box and return to the movie.

USING DOLBY™ HEADPHONE

The Dolby Headphone utility lets you enjoy multi-channel sound sources, such as movies, with realistic surround sound using your *conventional* stereo headphones.

Dolby Headphone is a signal processing system that enables your stereo headphones to realistically portray the sound of a five-speaker playback system.

POINTS

- Media discs which do not have the Dolby Surround 5:1 symbol will not support Dolby Headphone.
- After making changes to the Dolby Headphone feature and clicking OK, wait at least ten seconds before making another change in order to allow the system to stabilize.

To use the Dolby Headphone feature, perform the following steps:

1. Double click the InterVideo WinDVD icon on your desktop.
2. On the toolbar that appears, click the Properties button (the fourth button from the left, with the image of a wrench).
3. On the Properties window, select the Dolby Headphone tab.
4. To enable Dolby Headphone, check the Enable Dolby Headphone box. To change the type of surround sound, select one of the radio buttons listed under Room Filter Setting.

5. Click OK. The Dolby Headphone feature will now be enabled until you disable it by unchecking Enable Dolby Headphone.

USING THE MEDIA PLAYER ON BATTERY POWER

Since media player drives consume a lot of power, your overall battery life will be shorter when operating the media player drive continuously (such as watching a DVD movie). Many movie run-times are longer than your LifeBook notebook can support on a single battery. If you are watching a DVD movie on battery power you may need to swap in an additional, charged battery or attach AC power during the movie to view it in its entirety.

POINTS

- Prolonged use of the media player drive, such as watching a DVD movie, will substantially reduce your notebook's battery life.
- Many movie run-times are longer than your system can support on a single battery. If you are watching a DVD movie on battery power you may need to swap in an additional, charged battery or attach AC power during the movie to view it in its entirety.
- An additional fully-charged battery is highly recommended if you will be watching DVD movies on battery power. If you don't have an additional battery, you may purchase one either on-line at www.fujitsu-supc.com or call 1-877-372-3473.

To Watch a Movie on Battery Power:

1. Have an additional fully-charged battery or your AC adapter ready for use.
2. Start watching your DVD movie.
3. When the low battery warning occurs, immediately stop the movie and exit the media player.

CAUTION

If you do not stop the media player quickly and the LifeBook notebook attempts to auto-suspend (critical battery low state) the notebook will shut down improperly. If this occurs, you will need to perform a hard reset and follow the instruction, if any, presented to you before the system will reboot.

4. Manually place your notebook into suspend mode by depressing the Suspend button and replace the discharged battery with an additional full-charged battery. Or if you do not have an additional battery, you may attach AC power as soon as you see the low battery warning.

5. Resume your notebook by pressing the Suspend button again. This step is not required if you attached AC power without entering suspend mode.
6. Restart your media player, locate and skip to the chapter of the movie you were last watching.
7. Continue watching your DVD movie.

**POINT**

Some shorter DVD movies may not require you to swap batteries or attach AC power to complete them. However, it is best to be prepared since actual battery life while operating the media player drive cannot be guaranteed.

AUTO INSERT NOTIFICATION FUNCTION

The Auto Insert Notification function allows your Life-Book notebook to automatically start a DVD/CD as soon as it is inserted in the media player drive and the tray is closed. Your notebook will begin playing an audio DVD/CD or will start an application if the DVD/CD includes an auto run file.

To prevent a CD from playing automatically as soon as it is inserted, refer to the related help file for your specific operating system.

Hard Disk Drive

Your Fujitsu LifeBook notebook hard disk drive capacity is dependent on which model you are using. Some LifeBook notebooks may also contain a removable hard disk drive in addition to the internal hard disk drive. (See *Specifications on page 83 for more information*)

FORMATTING THE HARD DISK DRIVE

The internal hard disk drive is formatted, or initialized, at the factory. You do not need to format it under normal circumstances. If you decide to reformat due to corruption or upgrade, please refer to your operating system documentation for the correct procedure.



CAUTION

Reformatting the hard disk drive will erase all of the data currently stored on it, including the operating system and installed programs.

Before you reformat your hard disk drive, please note:

- Any data that currently resides on your hard disk drive must be backed-up to floppy disks or other data storage media, or it will be permanently lost. These back-up disks can then be used to reinstall and restore your data. (See *your operating system manual for more information on backing-up your data files*)
- All application software that is installed on the hard disk drive, must be reinstalled from the original source.
- The factory-installed software, including the operating system, can be restored using the Drive Image Special Edition (DISE) software that came with your LifeBook notebook (See *Drive Image Special Edition (DISE) on page 72 for more information*).

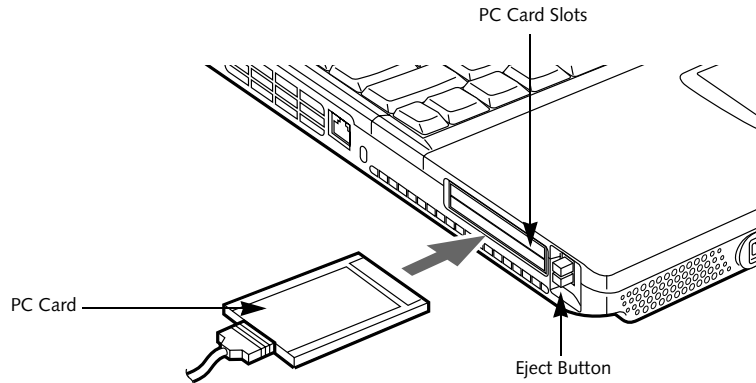

Figure 4-7 Installing/Removing PC Cards

PC Cards

Your LifeBook notebook supports two Type I and II and one Type III PC Cards, which can perform a variety of functions depending on which type of PC Card you install.

Some types of PC Cards available on the market include:

- Fax/data modem
- Local area network (LAN)
- Wireless LAN PC card
- IDE solid-state disk
- SCSI
- Other PC Cards that conform to PCMCIA™ 2.1 or CardBus standards.

For further information, refer to the instructions supplied with your PC Card.

INSTALLING PC CARDS

PC Cards are installed in the PC Card slots. To install a PC Card, follow these easy steps:

CAUTIONS

- Installing or removing a PC Card during your LifeBook notebook's shutdown or bootup process may damage the card and/or your notebook.
- Do not insert a PC Card if it not clean and dry. Inserting a dirty or wet card could damage your notebook.

1. See your PC Card manual for specific instructions on the installation of your card. Some PC Cards may require your LifeBook notebook to be Off while installing them.
2. Make sure there is no PC Card currently occupying the slot. If there is, see Removing PC Cards.

3. If either of the eject buttons is extended, press it in until it clicks.
4. Insert your PC Card into the slot with the product label facing up.
5. Push the card into the slot firmly until it is seated in the opening.

REMOVING PC CARDS

To remove a PC Card, perform the following steps:

1. See your PC Card manual for specific instructions on removing your card. Some PC Cards may require your notebook to be Off while removing them.

CAUTION

Loss of data could occur if proper shutdown procedures are not observed.

Windows 98 Second Edition has a shutdown procedure for PC Cards that must be followed before removing a card. Review your operating system manual for the correct procedure.

Windows 2000 Professional PC Cards should be stopped using the Unplug or Eject Hardware utility on the taskbar. Refer to your operating system manual for the correct procedure.

Windows XP has a Safe Removal of Hardware utility on the taskbar. Refer to your operating system manual for the correct procedure.

POINT

If the dialog box states that the device cannot be removed, you must save all of your open files, close any open applications and shut down your LifeBook notebook. Once your notebook has been shut down, you must turn Off the power using the power switch.

LifeBook E Series – Section 4

2. Unlock the PC Card from the slot by first pressing the eject button associated with the slot the card is in. When pressed, the button will pop up.
3. Firmly press the button again until it is flush with the notebook. This will push the PC Card slightly out of the slot allowing you to remove the card.

**CAUTION**

If the PC Card has an external connector and cable, do not pull the cable when removing the card.

SMARTCARD READER

An embedded SmartCard Reader is provided on your LifeBook notebook. SmartCards are the same size and shape as credit cards, but they contain an integrated microprocessor chip. The chip can hold a variety of different information, and provides the user with many possible options, such as allowing them to make secure purchases, pay for phone calls, store security information, and provide personal identification and information.

**POINT**

In order to use the embedded SmartCard Reader, you must purchase an optional SmartCard adapter for installation into an available Type II PC Card slot. For more information, visit our online store at www.fujitsupc.com.

Memory Upgrade Module

Your LifeBook notebook comes with 128MB or 256MB of memory factory installed. To increase your LifeBook notebook's memory capacity, you may install an additional memory upgrade module. You can also replace the original memory module with a higher capacity module. The memory upgrade must be a PC2100 DDR266 SO-DIMM module, but it can be any capacity up to 1024MB (total). To ensure 100% compatibility, we recommend that you only purchase additional memory from the Fujitsu on-line accessory store at: www.fujitsupc.com/accessories.

CAUTION

Do not remove any screws from the memory upgrade module compartment, except the ones specifically shown in the directions for installing and removing the memory upgrade module.

INSTALLING A MEMORY UPGRADE MODULE

1. Turn off power to your LifeBook notebook using the power switch, and remove any power adapter (AC or auto/airline).
2. Make sure that all the connector covers are closed.
3. Turn the LifeBook notebook bottom side up, with the front panel toward you.
4. Remove the screw at the front of the memory upgrade module compartment. (Figure 4-8)
5. Remove the cover by tilting the front edge up and then pulling forward until the tabs on the cover are free.

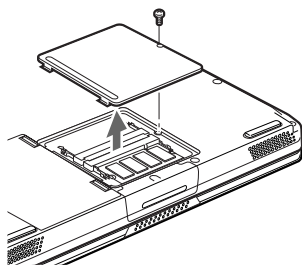

Figure 4-8. Opening the Memory Upgrade Compartment

CAUTION

The memory upgrade module can be severely damaged by electro-static discharge (ESD). Be sure you are properly grounded when handling and installing the module.

6. Remove the memory upgrade module from the static guarded sleeve.
7. Align the memory upgrade module with the part side up. Align the connector edge of the memory upgrade module with the connector slot in the compartment. The connector will be pointing toward the rear of the LifeBook notebook.
8. Insert the memory upgrade module at a 45° angle. Press the connector edge of the module firmly down and into the connector until it lodges under the retaining clip. You will hear a click when it is properly in place. (Figure 4-9)

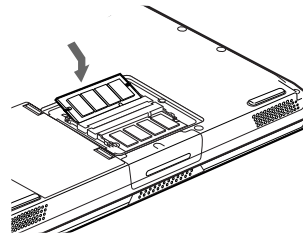

Figure 4-9. Installing a Memory Upgrade Module

9. Replace the cover by hooking the tabs under the rear edge of the compartment opening and tilting down until flush with the bottom of your LifeBook notebook.
10. Replace the screw.

POINT

The memory upgrade module is not something you should routinely remove from your notebook. Once it is installed, you should leave it in place unless you want to increase system memory capacity.

REMOVING A MEMORY UPGRADE MODULE

1. Perform steps 1 through 5 of Installing a Memory Upgrade Module.
2. Pull the clips sideways away from each side of the memory upgrade module at the same time.
3. While holding the clips out, remove the module from the slot by lifting it up and pulling towards the rear of your LifeBook notebook. (Figure 4-10)

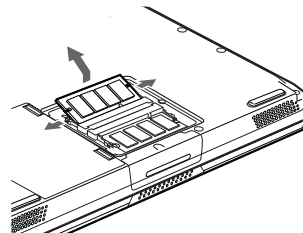

Figure 4-10. Removing a Memory Upgrade Module

4. Store the memory upgrade module in a static guarded sleeve.
5. Replace the cover by following steps 9 and 10 of Installing a Memory Upgrade Module.

POINT

After installing your added memory module, you must complete the Resetting the Save-to-Disk Parameters procedure in order for the Save-to-Disk mode to operate properly on your LifeBook notebook. (See *Hibernation (Save-to-disk) Feature on page 39 for more information*)

CHECKING THE COMPUTER RECOGNITION OF NEW MEMORY CAPACITY

Once you have changed the system memory capacity by either adding or removing a memory upgrade module, be sure to check that your notebook has recognized the change.

You can check the memory capacity by looking at the main menu of the BIOS setup:

1. Turn on the power to your LifeBook notebook using the power switch.
2. Allow the system to start booting and press the F2 key once the Fujitsu logo appears on the screen. This will open the main menu of the BIOS setup with the current settings displayed. (See *BIOS Setup Utility on page 35 for more information*)

The System Memory and the Extended Memory capacity, as detected by your LifeBook notebook during the Power On Self Test (POST), are displayed at the bottom of the main menu screen. The chart below shows you the possible displays that can be shown on the main menu screen. In the chart, Slot 1 is the original DR266 memory compartment while Slot 2 is the upgrade compartment located in the center of your LifeBook notebook.

POINT

If the total memory displayed is incorrect, check that your memory upgrade module is properly installed. (If the module is properly installed and the capacity is still not correctly recognized, see the Troubleshooting section starting on page 61)

Installed			Displayed	
Slot 1	Slot 2	Total RAM Installed	System Memory	Extended Memory
128MB	0MB	128MB	640K	127MB
128MB	128MB	256MB	640K	255MB
128MB	256MB	384MB	640K	383MB
256MB	0MB	256MB	640K	255MB
256MB	128MB	384MB	640K	383MB
256MB	256MB	512MB	640K	511MB
512MB	128MB	640MB	640K	639MB
512MB	256MB	768MB	640K	767MB
512MB	512MB	1024MB	640K	1023MB

Device Ports

Your LifeBook notebook comes equipped with multiple ports to which you can connect an external device including: disk drives, keyboards, modems, printers, etc.

COMMUNICATIONS PORTS

Your LifeBook has a Modem jack (RJ-11) and a LAN jack (RJ-45) to accommodate external communications.

Modem (RJ-11) Telephone Jack

The modem (RJ-11) telephone jack is used for your internal modem. To connect the telephone cable follow these easy steps: (See *Figure 2-5 on page 10 for location*)

1. Align the connector with the port opening.
2. Push the connector into the port until it is seated.
3. Plug the other end of the telephone cable into a telephone outlet.



CAUTION

Do not connect the internal modem to a Digital PBX as it may cause serious damage to the modem or your LifeBook notebook. It should be noted that some hotels use the Digital PBX systems, please be sure to find out BEFORE you connect your modem. Consult your PBX manufacturer's documentation for more information.



POINT

The internal modem is designed to the ITU-T V.90 standard. Its maximum speed of 53000bps is the highest allowed by the FCC, and its actual connection rate depends on the line conditions. The maximum speed is 33600bps at upload.

LAN PORT

This port allows you to connect a LAN (RJ-45) cable for high-speed network or broadband connections (e.g., DSL, cable modem). When your LifeBook notebook is connected to the Port Replicator, the LAN port on the system is not accessible; the Port Replicator LAN port is the only one that should be used when it is attached to the system. (See *Figure 2-5 on page 10 for location*)

WIRELESS LAN PORT

The optional Wireless LAN port allows you to connect with another device wirelessly. (See *Integrated Wireless LAN User's Guide on page 101 for more information*)

IEEE 1394 JACK

The 4-pin IEEE 1394 jack allows you to download digital files (such as digital video and images) to the computer at up to 400Mbps. Hot-swappable and plug-n-play, it is much faster than USB, CardBus, or parallel port. In order to connect a 1394 device, follow these steps: (See *Figure 2-4 on page 8 for location*)



POINT

The 1393 port in this system uses a four-pin configuration. If you intend to interface with devices which have a six-pin configuration, you will need to purchase an adapter.

PARALLEL PORT

The parallel port, or LPT port, allows you to connect parallel devices, such as a printer to your LifeBook notebook. In order to connect a parallel interface device follow these easy steps: (See *Figure 2-7 on page 12 for location*)

1. Align the connector with the port opening.
2. Push the connector into the port until it is seated.
3. Tighten the two hold-down screws, located on each end of the connector.

SERIAL PORT

The serial port, or COMM port, allows you to connect serial devices, such as printers or scanners. In order to connect a serial interface device follow these steps: (See *Figure 2-7 on page 12 for location*)

1. Align the connector with the port opening.
2. Push the connector into the port until it is seated.
3. Tighten the two hold-down screws, located on each end of the connector.

PS/2 PORT

The PS/2 port allows you to connect an external keyboard, numeric keypad, or mouse. In order to connect a PS/2 interface device follow these steps: (See *Figure 2-7 on page 12 for location*)

1. Align the connector with the port opening.
2. Push the connector into the port until it is seated.



POINTS

- A mouse, keyboard, or keypad may be installed and automatically recognized by your notebook without restarting or changing setups.
- The use of two PS/2 devices simultaneously from the port requires a PS/2 splitter.

UNIVERSAL SERIAL BUS PORTS

The Universal Serial Bus ports (USB) allow you to connect USB devices such as external game pads, pointing devices, keyboards and/or speakers. In order to connect a USB device follow these steps: (See *Figure 2-7 on page 12 for location*)

1. Align the connector with the port opening.
2. Push the connector into the port until it is seated.

INFRARED PORT

The Infrared IrDA 1.1 (4Mbps) port allows for wireless data transfer between your LifeBook notebook and other IrDA-compatible devices, such as another computer or a printer, without the use of a cable. (See Figure 2-5 on page 10 for location)

It is important to keep in mind that while carrying out this form of communication, both devices must be placed so their infrared ports are directly facing each other without obstruction. The devices must also be separated by at least 6" but no more than 36" for maximum performance.

The following conditions may interfere with infrared communications:

- A television, radio remote control unit, or a wireless headphone is being used nearby.
- Direct sunlight, fluorescent light, or incandescent light shines directly on the port.

**CAUTIONS**

- Do not move either device while communication is active as it may interrupt data transmission.
- Be careful not to scratch the infrared port lens. Scratches, dirt, or other surface marks can degrade operation.

**POINT**

With Windows 98 Second Edition, you can use the Infrared Recipient application for infrared file transfers.

With Windows 2000 Professional, file transfer is provided through Wireless Link in the Control Panel.

WIRELESS INFRARED MOUSE PORT

The optional Wireless Infrared Mouse Port allows you to use your wireless infrared (IR) Mouse. The IR Mouse communicates directly with the IR Mouse port without the use of a cable. (See Figure 2-4 on page 8 for location)

MICROPHONE JACK

The microphone jack allows you to connect an external mono microphone. Your microphone must be equipped with a 1/8" (3.5 mm) mono mini-plug in order to fit into the microphone jack of your LifeBook notebook. In order to connect a microphone follow these easy steps: (See Figure 2-4 on page 8 for location)

1. Align the connector with the port opening.
2. Push the connector into the port until it is seated.

S-VIDEO OUT PORT

The S-Video port allows you to connect and use directly any S-Video device, such as a VCR or television. The

S-Video standard provides for a higher quality picture than NTSC or PAL. In order to connect an S-Video device, follow these easy steps: (See Figure 2-7 on page 12 for location)

1. Align the connector with the port opening.
2. Push the connector into the port until it is seated.

HEADPHONE/SPDIF JACK

The headphone/SPDIF jack allows you to connect headphones, powered external speakers, or a MiniDisc recorder to your LifeBook notebook. Your device must be equipped with a 1/8" (3.5 mm) stereo mini-plug. In order to connect headphones or speakers follow these easy steps: (See Figure 2-4 on page 8 for location)

1. Align the connector with the port opening.
2. Push the connector into the port until it is seated.

**POINT**

If you plug headphones into the headphone jack, you will disable the built-in stereo speakers.

The optical digital audio-out feature of this jack allows you to download digital audio to MiniDisc recorders using SPDIF (Sony Philips Digital Interface) format. Please use the following setting when using the jack for digital audio-out.

1. Click on **Start -> Settings**, then click on **Control Panel**.
2. Select **Yamaha Ds-XG Audio Configuration**.
3. Click on the **SPDIF** tab and click **ON (Digital Sources Only)**. If you don't see this setting, the optical digital is always on by default.

**POINTS**

- The frequency of the digital sound output from the SPDIF output connector is fixed to 48KHz. If a sampling rate convertor is not installed in your connecting digital electronic device (e.g., MD player), recording is not possible. Please see the user manuals for the electronic devices for further details.
- The sound recorded through connecting a digital electronic device (e.g., MD player) to the SPDIF output connector cannot be used as digital output. All output data from the SPDIF output connector has copyright protection information included.
- Be careful in your choice of cable, as there are several types of cables for connecting a digital electronic device (e.g. MD player) to the digital audio-out connector, depending on the connector type. The connector on your computer is a Optical Mini Plug (3.5mm diameter mini plug).

DOCKING PORT

The docking port is used for the connection of your notebook to an optional port replicator or docking station. In order to connect your notebook to one of these devices follow the instructions that came with your port replicator or docking station. (See *Figure 2-7 on page 12 for location*)

CAUTION

Some LifeBook notebooks have a sliding panel that encloses the ports. The sliding panel can be damaged if it is left open while the notebook is moved.

EXTERNAL MONITOR PORT

The external monitor port allows you to connect an external monitor. In order to connect an external monitor follow these easy steps: (See *Figure 2-7 on page 12 for location*)

1. Align the connector with the port opening.
2. Push the connector into the port until it is seated.
3. Tighten the two hold-down screws, located on each end of the connector.

POINT

Pressing the [Fn] + [F10] keys allows you to change your selection of where to send your display video. Each time you press the key combination, you will step to the next choice, starting with the built-in display panel only, moving to the external monitor only, finally moving to both the built-in display panel and an external monitor.

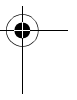
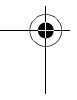

LifeBook E Series - Section 4

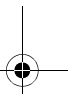
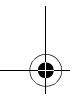
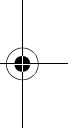
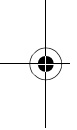

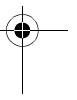
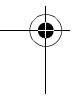

5 Troubleshooting

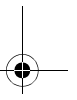
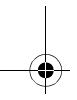
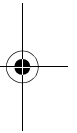
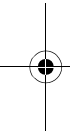

LifeBook E Series - Section 5

Troubleshooting

Your LifeBook notebook is sturdy and subject to few problems in the field. However, you may encounter simple setup or operating problems that you can solve on the spot, or problems with peripheral devices, that you can solve by replacing the device. The information in this section helps you isolate and resolve some of these straightforward problems and identify failures that require service.

FUJITSU SERVICE ASSISTANT

Your LifeBook notebook includes a sophisticated, full-featured troubleshooting utility that can assist you in solving most problems you might encounter. The Fujitsu Service Assistant is an interactive support tool that provides automated diagnosis and solutions for your hardware and software problems. This tool is located in one or more of the following locations:

- A Fujitsu Service Assistant icon on your desktop
- In the Start -> Service and Support folder
- On a separate Fujitsu Service Assistant CD included with your system

New support information for the Fujitsu Service Assistant tool may be available after the purchase of your notebook. You should periodically connect to the Internet while using the Fujitsu Service Assistant tool to ensure that you are using the most current version.

IDENTIFYING THE PROBLEM

If you encounter a problem that cannot be solved using the Fujitsu Service Assistant, go through the following procedure before pursuing further troubleshooting:

1. Turn off your LifeBook notebook.
2. Make sure the AC adapter is plugged into your LifeBook notebook and to an active AC power source.
3. Make sure that any card installed in the PC Card slot is seated properly. You can also remove the card from the slot, thus eliminating it as a possible cause of failure.
4. Make sure that any devices connected to the external connectors are plugged in properly. You can also disconnect such devices, thus eliminating them as possible causes of failure.
5. Turn on your LifeBook notebook. Make sure it has been off at least 10 seconds before you turn it on.
6. Go through the boot sequence.
7. If the problem has not been resolved, refer to the Troubleshooting Table, that follows, for more detailed troubleshooting information.

POINT

If you keep notes about what you have tried, your support representative may be able to help you more quickly by giving additional suggestions over the phone.

8. If you have tried the solutions suggested in the Troubleshooting Table without success, contact your support representative:

Toll free: 1-800-8Fujitsu (1-800-838-5487)

Fax: 1-901-259-5700

E-mail: 8fujitsu@fujitsupc.com

Web site: <http://www.fujitsupc.com>.

Before you place the call, you should have the following information ready so that the customer support representative can provide you with the fastest possible solution:

- Product name
- Product configuration number
- Product serial number
- Purchase date
- Conditions under which the problem occurred
- Any error messages that have occurred
- Hardware configuration
- Type of device connected, if any

See the Configuration Label on the bottom of your LifeBook notebook for configuration and serial numbers. (See Figure 2-8 on page 13 for location)

POINT

Do not return a failed LifeBook notebook to Fujitsu PC Corporation until you have received a Return Material Authorization (RMA) number from a support representative.

SPECIFIC PROBLEMS

Using the Troubleshooting Table

When you have problems with your LifeBook notebook, try to find the symptoms under the Problem column of the troubleshooting table for the feature giving you difficulty.

TROUBLESHOOTING TABLE

You will find a description of common causes for that symptom under the column Possible Cause and what, if anything, you can do to correct the condition under Possible Solutions. All possible causes or solutions may not apply to your LifeBook notebook.

Problem	Page
Audio Problems	page 62
DVD/CD-ROM Drive Problems	page 62
Docking Problems	page 63
Floppy Disk Drive Problems	page 63
Hard Drive Problems	page 63
Keyboard or Mouse Problems	page 63
Memory Problems	page 64
Modem Problems	page 64
Parallel, Serial and USB Device Problems	page 64
PC Card Problems	page 65
Power Failures	page 65
Shutdown and Start-up Problems	page 67
Video Problems	page 67
Miscellaneous Problems	page 69

Problem	Possible Cause	Possible Solutions
Audio Problems		
There is no sound coming from the built-in speakers.	The volume is turned too low.	Adjust the volume control on your notebook.
	The software volume control is set too low.	Adjust the sound volume control settings in your software, operating system and applications.
	Headphones are plugged into your notebook.	Plugging in headphones disables the built-in speakers, remove the headphones.
	BIOS audio settings are incorrect.	Set the BIOS setup utility to the default values within the Multimedia Device Configuration menu. <i>(See BIOS Setup Utility on page 35 for more information)</i>
	Software driver is not configured correctly.	Refer to your application and operating system documentation for help.
DVD/CD-ROM Drive Problems		
Notebook fails to recognize DVD/CDs.	DVD/CD is not pushed down onto raised center circle of the drive.	Open DVD/CD-ROM tray and re-install DVD/CD properly.
	DVD/CD-ROM tray is not latched shut.	Push on the front of the DVD/CD-ROM tray until it latches.
	Setup utility is set to something other than DVD/CD-ROM or Auto for the Secondary Master Controller.	Revise BIOS settings for the Secondary Master Controller. <i>(See BIOS Setup Utility on page 35 for more information)</i>
	Wrong drive designator was used for DVD/CD in the application.	Verify that the drive designator used by the application is the same as that used by the operating system. When the operating system is booted from a DVD/CD, drive designations are automatically adjusted.
	Windows DVD/CD Auto Insert Notification function is disabled.	Start the DVD/CD from the desktop or application software or re-enable the Windows DVD/CD Auto Insert Notification function. <i>(See Auto Insert Notification Function on page 49 for more information)</i>
	DVD/CD is dirty or defective.	Wipe DVD/CD with a non-abrasive CD cleaning cloth and reinsert. If it still will not work try another DVD/CD in the drive.

Troubleshooting

Problem	Possible Cause	Possible Solutions
LifeBook notebook fails to auto-play DVD movie.	DVD Player Software is not installed.	Install DVD Player Software using the DVD Application.
The DVD/CD-ROM Access indicator on the Status Indicator Panel blinks at regular intervals when no disk is in the tray or the DVD drive is not installed.	The Windows DVD/CD Auto Insert Notification function is active and is checking to see if a DVD/CD is ready to run.	This is normal. However, you may disable this feature. (See <i>Auto Insert Notification Function on page 49 for more information</i>)
Docking Problems		
Notebook does not turn on when installed in Docking Station.	LAN Dock AC adapter is not plugged in.	Provide power to the LAN Docking Station.
	Notebook is not properly seated in the LAN Dock.	Remove and re-dock your notebook and verify that the Docked LED illuminates.
Floppy Disk Drive Problems		
You cannot access your floppy disk.	You tried to write to a write protected floppy disk.	Eject the floppy disk and set it to write enable. (See <i>External USB Floppy Disk Drive on page 45 for more information</i>)
	Floppy disk is not loaded correctly.	Eject floppy disk, check orientation and reinsert. (See <i>External USB Floppy Disk Drive on page 45 for more information</i>)
	BIOS setup utility states Diskette Controller: Disabled.	Revise the setup utility Main menu settings to enable Diskette Controller. (See <i>BIOS Setup Utility on page 35 for more information</i>)
	The floppy disk drive may not be properly installed.	Remove and reinstall your floppy disk drive. (See <i>Flexible Bay Devices on page 23 for more information</i>)
	Security is set to protect access to floppy disk data.	Verify your password and security settings.
Hard Drive Problems		
You cannot access your hard drive.	The setup utility is incorrectly set for your internal hard drive.	Set Primary Master correctly in the BIOS. (See <i>BIOS Setup Utility on page 35 for more information</i>)
	The wrong drive designator was used by an application when a bootable CD-ROM was used to start the notebook.	Verify drive designator used by application is in use by the operating system. When the operating system is booted from a CD, drive designations are automatically adjusted.
	Security is set so your operating system cannot be started without a password.	Verify your password and security settings.
Keyboard or Mouse Problems		
The built-in keyboard does not seem to work.	The notebook has gone into Suspend mode.	Push the Power and Suspend/Resume button.
	Your application has locked out your keyboard.	Try to use your intergrated pointing device to restart your system. If this fails, turn your LifeBook notebook off using the power switch, wait 10 seconds or more, and then turn it back on.
	The NumLock key is set.	Press the NumLock key to reset it.

LifeBook E Series – Section 5

Problem	Possible Cause	Possible Solutions
You have installed an external keyboard or mouse, and it does not seem to work.	Your external device is not properly installed.	Reinstall your device. (See <i>Device Ports</i> on page 55 for more information)
	Your operating system software is not set up with the correct driver for that device.	Check your device and operating system documentation and activate the proper driver.
	Your mouse or keyboard is connected to the wrong PS/2 port on the LAN Dock.	Plug the mouse into the PS/2 Mouse port and the external keyboard or numeric key pad into the PS/2 Keyboard port. (See <i>Device Ports</i> on page 55 for more information)
You have connected an external keyboard or a mouse and it seems to be locking up the system.	Your operating system software is not setup with the correct software driver for that device.	Check your device and operating system documentation and activate the proper driver.
	Your system has crashed.	Try to restart your LifeBook notebook. If that fails, turn off the power using the power switch, wait at least 10 seconds, and then power on.
Memory Problems		
Your Power On screen, or Main menu of the BIOS setup utility information, does not show the correct amount of installed memory.	Your memory upgrade module is not properly installed.	Remove and reinstall your memory upgrade module. (See <i>Memory Upgrade Module</i> on page 53 for more information)
	You have a memory failure.	Check for Power On Self Test (POST) messages. (See <i>Power On Self Test Messages</i> on page 70 for more information)
Modem Problems		
Messages about modem operation.	Messages about modem operation are generated by whichever modem application is in use.	See your application software documentation for additional information.
Parallel, Serial, and USB Device Problems		
You have installed a parallel port device, a serial port device or a USB device. Your LifeBook notebook does not recognize the device, or the device does not seem to work properly.	The device is not properly installed.	Remove and reinstall the device. (See <i>Device Ports</i> on page 55 for more information)
	The device may have been installed while an application was running, so your notebook is not aware of its installation.	Close the application and restart your LifeBook notebook.
	Your software may not have correct software driver active.	See your software documentation and activate the correct driver.
	You may have the wrong I/O address selected for your device.	See your device documentation and software documentation to determine the required I/O address. Change the settings in the BIOS setup utility. (See <i>BIOS Setup Utility</i> on page 35 for more information)
	Your device and another device are assigned the same I/O address.	Check all I/O addresses located within the BIOS setup utility and any other installed hardware or software to make sure there are no duplications.
	Parallel port is set to output only.	Check parallel port setting in the BIOS and set to bi-directional or ECP.

Troubleshooting

Problem	Possible Cause	Possible Solutions
PC Card Problems		
A card inserted in the PC Card slot does not work or is locking up the system.	The card is not properly installed.	Remove and reinstall the card. (See <i>PC Cards on page 51 for more information</i>)
	The card may have been installed while an application was running, so your notebook is not aware of its installation.	Close the application and restart your LifeBook notebook.
	Your software may not have the correct driver active.	See your software documentation and activate the correct driver.
	You may have the wrong I/O address selected for your PC Card device.	See your PC Card documentation to determine the required I/O address. Change the settings in the BIOS. (See <i>BIOS Setup Utility on page 35 for more information</i>)
	Your PC Card device and another device are assigned the same I/O address.	Check all I/O addresses located within the BIOS setup utility and any other installed hardware or software to make sure there are no duplications.
Power Failures		
You turn on your LifeBook notebook and nothing seems to happen.	The installed primary battery is completely discharged, there is no optional second battery installed or there is no Power adapter (AC or Auto/Airline) installed.	Check the Status Indicator Panel to determine the presence and condition of the batteries. (See <i>Status Indicator Panel on page 14 for more information</i>) Install a charged battery or a Power adapter.
	The primary battery is installed but is faulty.	Use the Status Indicator panel to verify the presence and condition of the batteries. (See <i>Status Indicator Panel on page 14 for more information</i>) If a battery is indicating a short, remove that battery and operate from another power source or replace that battery.
	The battery or batteries are low.	Check the Status Indicator Panel to determine the presence and condition of the batteries. (See <i>Status Indicator Panel on page 14 for more information</i>) Use a Power adapter to operate until a battery is charged or install a charged battery.
	The power adapter (AC or auto/airline) is not plugged in properly.	Verify that your adapter is connected correctly. (See <i>Power Sources on page 33 for more information</i>)
	The Power adapter (AC or auto/airline) has no power from the AC outlet, airplane seat jack, or the car's cigarette lighter.	Move the AC cord to a different outlet, check for a line switch or tripped circuit breaker for the AC outlet. If you are using an auto/airline adapter in a car make sure the ignition switch is in the On or Accessories position.
	The Power adapter (AC or auto/airline) is faulty.	Try a different Power adapter or install a charged optional second battery.

LifeBook E Series – Section 5

Problem	Possible Cause	Possible Solutions
Your LifeBook notebook turns off all by itself.	The power management parameters are set for auto timeouts which are too short for your operating needs.	Press any button or key on the keyboard, or move the mouse to restore operation. If that fails, push the Power and Suspend/Resume button. Check your power management settings, or close your applications and go to the Power Savings menu of the setup utility to adjust the timeout values to better suit your operation needs.
	You are operating on battery power only and have ignored a low battery alarm until the batteries are all at the dead battery state and your machine has gone into Dead Battery Suspend mode.	Install a power adapter and then push the Power and Suspend/Resume button. (<i>See Power Sources on page 33 for more information</i>)
	You have a battery failure.	Verify the condition of the batteries using the Status Indicator panel, and replace or remove any batteries that are shorted. (<i>See Status Indicator Panel on page 14 for more information</i>)
	Your power adapter has failed or lost its power source.	Make sure the adapter is plugged in and the outlet has power.
Your LifeBook notebook will not work on battery alone.	The installed batteries are dead.	Replace the battery with a charged one or install a Power adapter.
	No batteries are installed.	Install a charged battery.
	The batteries are improperly installed.	Verify that the batteries are properly connected by re-installing them.
	Your installed batteries are faulty.	Verify the condition of the batteries using the Status Indicator panel and replace or remove any batteries that are shorted. (<i>See Status Indicator Panel on page 14 for more information</i>)
The batteries seem to discharge too quickly.	You are running an application that uses a great deal of power due to frequent hard drive access or DVD/CD-ROM access, use of a modem card or a LAN PC card.	Use both the primary battery and an optional second battery and/or use a power adapter for this application when at all possible.
	The power savings features may be disabled.	Check the power management and/or setup utility settings in the Power Savings menu and adjust according to your operating needs.
	The brightness is turned all the way up.	Turn down the brightness adjustment. The higher the brightness the more power your display uses.
	The batteries are very old.	Replace the batteries.
	The batteries have been exposed to high temperatures.	Replace the batteries.
	The batteries are too hot or too cold.	Restore the LifeBook notebook to normal operating temperature. The Charging icon on the Status Indicator panel will flash when the battery is outside its operating range.

Troubleshooting

Problem	Possible Cause	Possible Solutions
Shutdown and Startup Problems		
The Power and Suspend/Resume button does not work.	The Power and Suspend/Resume button is disabled from the Power -> Advanced submenu of the setup utility.	Enable the button from the setup utility.
	You did not hold the button in long enough.	Hold the button longer. This may need to be a few seconds if your application is preventing the CPU from checking for button pushes.
	There may be a conflict with the application software.	Close all applications and try the button again.
The system powers up, and displays power on information, but fails to load the operating system.	The boot sequence settings of the setup utility are not compatible with your configuration.	Set the operating source by pressing the [ESC] key while the Fujitsu logo is on screen or use the [F2] key and enter the setup utility and adjust the source settings from the Boot menu. <i>(See BIOS Setup Utility on page 35 for more information)</i>
	You have a secured system requiring a password to load your operating system.	Make sure you have the right password. Enter the setup utility and verify the Security settings and modify them accordingly. <i>(See BIOS Setup Utility on page 35 for more information)</i>
	Internal hard drive was not detected.	Use the BIOS setup utility or Primary Master submenu, located within the Main menu, to try to auto detect the internal hard drive.
Your system display won't turn on when the system is turned on or when the system has resumed.	The system may be password-protected.	Check the status indicator panel to verify that the Security icon is blinking. If it is blinking, enter your password.
An error message is displayed on the screen during the notebook (boot) sequence.	Power On Self Test (POST) has detected a problem.	See the POST messages to determine the meaning and severity of the problem. Not all messages are errors; some are status indicators. <i>(See Power On Self Test Messages on page 70 for more information)</i>
Your LifeBook notebook appears to change setup parameters when you start it.	BIOS setup changes were not saved when you exited the BIOS setup utility, returning it to previous settings.	Make sure you select Save Changes And Exit when exiting the BIOS setup utility.
	The BIOS CMOS hold-up battery has failed.	Contact your support representative for repairs. This is not a user serviceable part but has a normal life of 3 to 5 years.
Video Problems		
The built-in display is blank when you turn on your LifeBook notebook.	Something is pushing on the Closed Cover switch.	Clear the Closed Cover switch. <i>(See Figure 2-4 on page 8 for location)</i>
	The angle of the display and the brightness settings are not adequate for your lighting conditions.	Move the display and the brightness control until you have adequate visibility.

LifeBook E Series – Section 5

Problem	Possible Cause	Possible Solutions
The built-in display is blank when you turn on your LifeBook notebook. (continued)	The LifeBook notebook is set for an external monitor only.	Pressing [F10] while holding down the [Fn] key allows you to change your selection of where to send your display video. Each time you press the combination of keys you will step to the next choice. The choices, in order are: built-in display only, external monitor only, both built-in display and external monitor.
	The power management time-outs may be set for very short intervals and you failed to notice the display come on and go off again.	Press any button or key on the keyboard, or move the mouse to restore operation. If that fails, push the Power and Suspend/Resume button. (The display may be shut off by Standby mode, Auto Suspend or Video Timeout.)
The LifeBook notebook turned on with a series of beeps and your built-in display is blank.	Power On Self Test (POST) has detected a failure which does not allow the display to operate.	Contact your support representative.
Your system display won't turn on when the system is turned on or when the system has resumed.	The system may be password-protected.	Check the status indicator panel to verify that the Security icon is blinking. If it is blinking, enter your password.
The display goes blank by itself after you have been using it.	The notebook has gone into Video timeout, Standby mode, Suspend mode or Save-to-Disk mode because you have not used it for a period of time.	Press any button or key on the keyboard, or move the mouse to restore operation. If that fails, push the Power and Suspend/Resume button. Check your power management settings, or close your applications and go to the Power Savings menu of the setup utility to adjust the timeout values to better suit your operation needs. (See <i>BIOS Setup Utility on page 35 for more information</i>)
	Something is pushing on the Closed Cover switch.	Check the Closed Cover switch. (See <i>Figure 2-4 on page 8 for location</i>)
	The power management time-outs may be set for very short intervals and you failed to notice the display come on and go off again.	Press any button or key on the keyboard, or move the mouse to restore operation. If that fails, push the Power and Suspend/Resume button. (The display may be shut off by Standby Mode, Auto Suspend or Video Timeout.)
The Built-in Display does not close.	A foreign object, such as a paper clip, is stuck between the display and the keyboard.	Remove all foreign objects from the keyboard.
The Built-in Display has bright or dark spots.	If the spots are very tiny and few in number, this is normal for a large LCD display.	This is normal; do nothing.
	If the spots are numerous or large enough to interfere with your operation needs.	Display is faulty; contact your support representative.
You have connected an external monitor and it does not come on.	Your external monitor is not compatible with your LifeBook notebook.	See your monitor documentation and the External Monitor Support portions of the Specifications section on page 83.

Troubleshooting

Problem	Possible Cause	Possible Solutions
The application display uses only a portion of your screen and is surrounded by a dark frame.	You are running an application that does not support 800 x 600 pixel resolution display and display compression is enabled.	Display compression gives a clearer but smaller display for applications that do not support 800 x 600 pixel resolution. You can fill the screen but have less resolution by changing your display compression setting, (See the Video Features submenu, located within the Advanced menu of the BIOS.) (See <i>BIOS Setup Utility on page 35 for more information</i>)
You have connected an external monitor and it does not display any information.	Your BIOS setup is not set to enable your external monitor.	Try toggling the video destination by pressing [Fn] and [F10] together, or check your BIOS setup and enable your external monitor. (See the Video Features submenu, located within the Advanced Menu of the BIOS.) (See <i>BIOS Setup Utility on page 35 for more information</i>)
	Your external monitor is not properly installed.	Reinstall your device. (See <i>External Monitor Port on page 57 for more information</i>)
	Your operating system software is not setup with the correct software driver for that device.	Check your device and operating system documentation and activate the proper driver.
Miscellaneous Problems		
An error message is displayed on the screen during the operation of an application.	Application software often has its own set of error message displays.	See your application manual and help displays screens for more information. Not all messages are errors some may simply be status.

POWER ON SELF TEST MESSAGES

The following is an alphabetic list of error-and-status messages that Phoenix BIOS and/or your operating system can generate and an explanation of each message. Error messages are marked with an *. The most common errors are marked with a #. If an error message is displayed that is not in this list, write it down and check your operating system documentation both on screen and in the manual. If you can find no reference to the message and its meaning is not clear, contact your support representative for assistance.

nnnn Cache SRAM Passed

Where nnnn is the amount of system cache in kilobytes successfully tested by the Power On Self Test. (This can only appear if you have an SRAM PC Card installed.)

***Diskette drive A error or Diskette drive B error**

Drive A: or B: is present but fails the BIOS Power On Self Test diskette tests. Check to see that the drive is defined with the proper diskette type in the Setup Utility, (*See BIOS Setup Utility on page 35 for more information*) and that the diskette drive is installed correctly. If the disk drive is properly defined and installed, avoid using it and contact your support representative.

***Extended RAM Failed at offset: nnnn**

Extended memory not working or not configured properly. If you have an installed memory upgrade module, verify that the module is properly installed. If it is properly installed, you may want to check your Windows Setup to be sure it is not using unavailable memory until you can contact your support representative.

nnnn Extended RAM Passed

Where nnnn is the amount of memory in kilobytes successfully tested.

***Failing Bits: nnnn The hex number nnnn**

This is a map of the bits at the memory address (in System, Extended, or Shadow memory) which failed the memory test. Each 1 (one) in the map indicates a failed bit. This is a serious fault that may cause you to lose data if you continue. Contact your support representative.

***Fixed Disk x Failure or Fixed Disk Controller Failure (where x = 1-4)**

The fixed disk is not working or not configured properly. This may mean that the hard drive type identified in your setup utility does not agree with the type detected by the Power On Self Test. Run the setup utility to check for the hard drive type settings and correct them if necessary. If the settings are OK and the message appears when you restart the system, there may be a serious fault which might cause you to lose data if you continue. Contact your support representative.

***Incorrect Drive A type – run SETUP**

Type of floppy drive A: not correctly identified in Setup. This means that the floppy disk drive type identified in your setup utility does not agree with the type detected by the Power On Self Test. Run the setup utility to correct the inconsistency.

***Incorrect Drive B type – run SETUP**

Type of floppy drive B: not correctly identified in Setup. This means that the floppy disk drive type identified in your setup utility does not agree with the type detected by the Power On Self Test. Run the setup utility to correct the inconsistency.

***Invalid NVRAM media type**

Problem with NVRAM access. In the unlikely case that you see this message you may have some display problems. You can continue operating but should contact your support representative for more information.

***Keyboard controller error**

The keyboard controller test failed. You may have to replace your keyboard or keyboard controller but may be able to use an external keyboard until then. Contact your support representative.

***Keyboard error**

Keyboard not working. You may have to replace your keyboard or keyboard controller but may be able to use an external keyboard until then. Contact your support representative.

***Keyboard error nn**

BIOS discovered a stuck key and displays the scan code for the stuck key. You may have to replace your keyboard but may be able to use an external keyboard until then. Contact your support representative.

***Monitor type does not match CMOS – Run SETUP**

Monitor type not correctly identified in Setup. This error probably means your BIOS is corrupted, run the setup utility and set all settings to the default conditions. If you still get this error, contact your support representative.

#*Operating system not found

Operating system cannot be located on either drive A: or drive C:. Enter the setup utility and see if both the fixed disk, and drive A: are properly identified and that the boot sequence is set correctly. Unless you have changed your installation greatly, the operating system should be on drive C:. If the setup utility is correctly set, your hard drive may be corrupted and your system may have to be reinstalled from your back up media.

***Parity Check 1 nnnn**

Parity error found in the system bus. BIOS attempts to locate the address and display it on the screen. If it cannot locate the address, it displays ????. This is a potentially data-destroying failure. Contact your support representative.

***Parity Check 2 nnnn**

Parity error found in the I/O bus. BIOS attempts to locate the address and display it on the screen. If it cannot locate the address, it displays ????. This is a potentially data destroying failure. Contact your support representative.

Press <F1> to resume, <F2> to SETUP

Displayed after any recoverable error message. Press the [F1] key to continue the boot process or the [F2] key to enter Setup and change any settings.

Previous boot incomplete – Default configuration used

Previous Power On Self Test did not complete successfully. The Power On Self Test will load default values and offer to run Setup. If the previous failure was caused by incorrect values and they are not corrected, the next boot will likely fail also. If using the default settings does not allow you to complete a successful boot sequence, you should turn off the power with the Power Switch and contact your support representative.

***Real time clock error**

Real-time clock fails BIOS test. May require board repair. Contact your support representative.

***Shadow RAM Failed at offset: nnnn**

Shadow RAM failed at offset nnnn of the 64k block at which the error was detected. You are risking data corruption if you continue. Contact your support representative.

nnnn Shadow RAM Passed

Where nnnn is the amount of shadow RAM in kilobytes successfully tested.

***System battery is dead – Replace and run SETUP**

The BIOS CMOS RAM memory hold up battery is dead. This is part of your BIOS and is a board mounted battery which requires a support representative to change. You can continue operating but you will have to use setup utility default values or reconfigure your setup utility every time you turn off your LifeBook notebook. This battery has an expected life of 2 to 3 years.

System BIOS shadowed

System BIOS copied to shadow RAM.

***System CMOS checksum bad – run SETUP**

BIOS CMOS RAM has been corrupted or modified incorrectly, perhaps by an application program that changes data stored in BIOS memory. Run Setup and reconfigure the system.

***System RAM Failed at offset: nnnn**

System memory failed at offset nnnn of in the 64k block at which the error was detected. This means that there is a fault in your built-in memory. If you continue to operate, you risk corrupting your data. Contact your support representative for repairs.

nnnn System RAM Passed

Where nnnn is the amount of system memory in kilobytes successfully tested.

***System timer error**

The timer test failed. The main clock that operates the computer is faulty. Requires repair of system board. Contact your support representative for repairs.

UMB upper limit segment address: nnnn

Displays the address of the upper limit of Upper Memory Blocks, indicating released segments of the BIOS memory which may be reclaimed by a virtual memory manager.

Video BIOS shadowed

Video BIOS successfully copied to shadow RAM.

MODEM RESULT CODES

The operating system and application software that is factory installed detects the modem characteristics and provides the necessary command strings to operate the modem. The internal modem operation is controlled by generic AT commands from the operating system and application software. The standard long form result codes may, in some cases, be displayed on your screen to keep you informed of the actions of your modem. The operating system and application software may suppress display of the result codes.

Examples of result codes are:

- OK
- NO CARRIER
- NO DIALTONE
- CONNECT 53000 (Connection complete at 53,000 bps.)
- ERROR
- FAX
- RING (This means an incoming call.)
- BUSY
- NO ANSWER

When using the internal modem with applications that are not factory installed refer to the application documentation.

Restoring Your Pre-installed Software

Your system has been loaded with a valuable utility that allows you to restore your LifeBook notebook disk drive contents as they were originally shipped from the factory. Most often this is necessary if files or software programs (only those files/programs that came pre-installed) become corrupted or are accidentally erased.



POINT

Look for and open files with .doc and .txt extensions.

DRIVE IMAGE SPECIAL EDITION (DISE)

PowerQuest Drive Image Special Edition® (DISE) provides a way to restore your computer if you experience a hard disk crash or other system failure. Fujitsu has used DISE to create an image of everything installed on the computer at the time you purchased it. The image is saved on a separate partition on the hard disk. You can use DISE to restore the factory image and return your computer to the state in which it shipped from Fujitsu.

NOTE: Systems with the Windows 98 operating system installed have the DISE directory structure in place, but without the disk image or the DISE software installed. (See *Installing and Using DISE With Windows 98 Systems* on page 73 for more information)

Although it is not necessary, you can use DISE to store additional image files that you create. For example, if you install several applications and save data files on your hard disk, you can create a new image file that includes them and then save that image file on the hard disk. Then, in the event of a hard disk failure, you can restore the image that includes the applications and data files you use.

Fujitsu recommends that you create a DISE disk as a “rescue disk.” If your computer fails, you can boot and run DISE from the rescue disk.



POINT

Using the DISE feature will reduce the amount of usable disk space on your hard disk drive.

USING DISE WITH WINDOWS 2000/XP

Creating a Drive Image SE Diskette

You can use a DISE disk to boot your machine and run DISE if your machine is unbootable or if you do not have access to Windows.

Insert a formatted floppy disk in your machine.

From the Drive Image Special Edition main window, click **Options > Create Drive Image SE Diskette**.

Running DISE from Diskettes

1. Insert the Drive Image SE Disk 1 in the floppy drive.
2. Reboot your computer.
3. Insert Disk 2, type DISE, then press <Enter>.

Creating a Backup Image

You can create a backup image of your C:\ drive at any time. The C:\ partition must be a FAT, FAT32, or NTFS partition, and it must be directly before the backup partition on your hard disk.

1. At the Drive Image Special Edition main screen, click **Options> Create New Backup**.
There is also a button on the main DISE screen that performs the same function.
2. You will be prompted to type a password. Type a password (or leave the password fields blank), then click **OK**. DISE displays a warning that it must go to DOS to create the image.

3. Click **Yes**.

DISE creates an image file in the backup partition. If you created a backup image previously, the new image overwrites the old one.

Enlarging the Backup Partition

If there is not enough unused space in the backup partition on your hard disk, DISE will resize the partition. DISE will display the minimum, maximum, and recommended sizes for the backup partition. You choose the size you want.

DISE takes the space from the FAT, FAT32, or NTFS partition that you are backing up. If there is not enough unused space in that partition to take, you will not be able to resize the backup partition and create an image file. You can delete files from the FAT, FAT32, or NTFS partition to create more unused space on the hard disk.

Restoring a Backup Image

You can restore either a factory image or a backup image you created. Be aware that restoring a backup image will replace the contents of the C:\ partition with the image you restore.

1. Disable virus protection software in the BIOS. If virus protection software is enabled, DISE will hang.
2. From the DISE main window, click **Options > Restore Backup** to restore an image you created, or click **Options > Restore Factory Backup** to restore the factory image.

DISE shuts down to DOS and restores the image file.

Drivers and Applications Restore CD

The Drivers and Application CD can be used to selectively re-install drivers and/or applications that may have been un-installed or corrupted. Please refer to installation instructions located in the Drivers and Applications Restore CD.

 **POINT**

Look for and open files with the extensions .WRI, .DOC, .PDF and/or .TXT.

INSTALLING AND USING DISE WITH WINDOWS 98 SYSTEMS

Systems with Windows 98 installed have the DISE directory structure in place, but without the disk image or the DISE software installed.

When DISE is completely installed, the DISE backup partition requires approximately 1.8GB of hard disk space in Windows 98 systems. This number reflects the size of the original Fujitsu Factory Image; if additional applications are added by the reseller, the amount of space required will be proportionately greater.

Factory Backup Image: This is the image that is originally delivered from the factory or the reseller.

User Backup Image: This is the modified Factory Image containing any applications or changes that have been added by the user.

This document outlines the procedure for creating the Factory Backup Image on the hard drive using the DISE utility. (The User Backup Image is designed for the end-user, and can be invoked from the desktop using the DISE icon.)

 **POINT**

If a DISE backup partition is not created for Master and/or User backups, the Factory Backup Image may not be recoverable.

Creating the Backup Partition and Installing DISE on Windows 98

In order to provide a dedicated area on the hard disk to store the image, you must first partition the disk.

1. Go to the C:\FPC\INSTALL\POWERQUEST directory and double-click on SETUP.EXE. The Welcome screen appears.
2. Click Next.
3. Depending upon whether you are creating a Factory Backup Image, a User Backup Image, or both, check the applicable box(es). Be aware that the numbers displayed represent Megabytes of disk space that will be reserved to store the image. The following list indicates the approximate size of the partition required for Windows 98 systems:
One image - 1024MB
Two images - 1.8GB

4. Click [Next]. If the information displayed is correct, click Finish to create the partition. The system will automatically reboot and complete the operation.
5. When the message "The operation completed successfully" appears, click [OK]. The system will reboot.

Creating a Factory Backup Image

To create a Factory Backup Image, first partition the disk, as outlined above. After the disk is partitioned, proceed with the following steps.

 **POINT**

The following step may require a bootable DOS diskette.

1. Boot the system up into DOS.
2. From the DISE directory, type and enter the following command (Note the spaces after "DISE", ".TXT", and ".PQI"):

```
DISE /CMD=CREATE.TXT /IMG=FACTORY.PQI /SEC
```

3. After the Factory Backup Image is created, an "Operation completed successfully" message appears. Click [OK]. The system will reboot automatically.

Creating Drive Image SE Diskettes

It is recommended that you create DISE diskettes for the system. You can use a DISE disk to boot the machine and run DISE in the event the machine is unbootable or if you do not have access to Windows.

1. Insert a formatted floppy disk in the drive.
2. From the Drive Image Special Edition main window, click **Options > Create Drive Image SE Diskette**. Follow the instructions displayed.
3. After diskettes have been created, label them Disk 1 and Disk 2.

Running Drive Image SE from Diskettes

1. Insert Drive Image SE Disk 1 in the drive.
2. Reboot the computer.
3. Insert Disk 2, type DISE, then press <Enter>.

Additional information about DISE is contained in the following location on the hard drive:

C:\DISE\dise_end.pdf. There is also a shortcut icon on the desktop to access the DISE readme file.

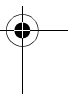
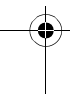

LifeBook E Series - Section 5

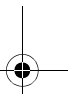
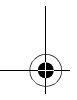
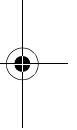
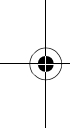



6

Care and Maintenance

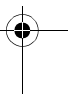
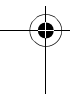

LifeBook E Series - Section 6

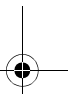
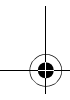
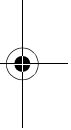
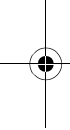

Care and Maintenance

If you use your LifeBook notebook carefully, you will increase its life and reliability. This section provides some tips for looking after the notebook and its devices.

WARNING

Electrical equipment may be hazardous if misused. Operations of this product or similar products, must always be supervised by an adult. Do not allow children access to the interior of any electrical products and do not permit them to handle any cables.

LIFEBOOK NOTEBOOK

Caring for your Notebook

- Your LifeBook notebook is a durable but sensitive electronic device. Treat it with respect and care.
- Make a habit of transporting it in a suitable carrying case.
- Do not attempt to service the computer yourself. Always follow installation instructions closely.
- Keep it away from food and beverages.
- If you accidentally spill liquid on your notebook:
 1. Turn it off.
 2. Position it so that the liquid can run out.
 3. Let it dry out for 24 hours, or longer if needed.
 4. If your notebook will not boot after it has dried out, call your support representative.
- Do not use your LifeBook notebook in a wet environment (near a bathtub, swimming pool).
- Always use the AC adapter and batteries that are approved for your LifeBook notebook.
- Avoid exposure to sand, dust and other environmental hazards.
- Do not expose your LifeBook notebook to direct sunlight for long periods of time as temperatures above 140° F (60° C) may damage your notebook.
- Keep the covers closed on the connectors and slots when they are not in use.
- Do not put heavy or sharp objects on the computer.
- If you are carrying your LifeBook notebook in a briefcase, or any other carrying case, make sure that there are no objects in the case pressing on the lid.
- Do not drop your LifeBook notebook.
- Do not touch the screen with any sharp objects.

Cleaning your LifeBook notebook





- Always disconnect the power plug. (Pull the plug, not the cord.)
- Clean your LifeBook notebook with a damp, lint-free cloth. Do not use abrasives or solvents.
- Use a soft cloth to remove dust from the screen. Never use glass cleaners.

Storing your LifeBook notebook

- If storing your LifeBook notebook for a month or longer, turn your LifeBook off and remove all Lithium ion batteries.
- Store your LifeBook notebook and batteries separately. If you store your notebook with a battery installed, the battery will discharge, and battery life will be reduced. In addition, a faulty battery might damage your notebook.
- Store your notebook in a cool, dry location. Temperatures should remain between 13°F (-25°C) and 140°F (60°C).

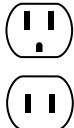
Traveling with your LifeBook notebook

- Do not transport your LifeBook notebook while it is turned on.
- Do not check your LifeBook notebook as baggage. Carry it with you.
- Always bring your System Recovery CD (Windows 98 and Windows 2000 systems only) that came with your notebook when you travel. If you experience system software problems while traveling, you may need it to correct any problems.
- When traveling with the hard drive removed, wrap the drive in a non-conducting materials (cloth or paper). If you have the drive checked by hand, be ready to install the drive if needed. Never put your hard drive through a metal detector. Have your hard drive hand-inspected by security personnel. You can however, put your hard drive through a properly tuned X-ray machine.
- Take the necessary plug adapters if you're traveling overseas. Check the following diagram to determine which plug adapter you'll need or ask your travel agent.

Outlet Type	Location
	United States, Canada, parts of Latin America, Japan, Korea, the Philippines, Taiwan
	Russia and the Commonwealth of Independent States (CIS), most of Europe, parts of Latin America, the Middle East, parts of Africa, Hong Kong, India, most of South Asia
	Mexico, United Kingdom, Ireland, Malaysia, Singapore, parts of Africa
	China, Australia, New Zealand

BATTERIES

Caring for your Batteries

- Always handle batteries carefully.
- Do not short-circuit the battery terminals (that is, do not touch both terminals with a metal object). Do not carry loose batteries in a pocket or purse where they may mix with coins, keys, or other metal objects. Doing so may cause an explosion or fire.
- Do not drop, puncture, disassemble, mutilate or incinerate the battery.
- Recharge batteries only as described in this manual and only in ventilated areas.
- Do not leave batteries in hot locations for more than a day or two. Intense heat can shorten battery life.
- Do not leave a battery in storage for longer than 6 months without recharging it.

Increasing Battery Life

- Power your LifeBook notebook through the AC or optional auto/airline adapter whenever possible.
- If your LifeBook notebook is running on battery power all day, connect it to the AC adapter overnight to recharge the battery.
- Keep brightness to the lowest level comfortable.
- Set the power management for maximum battery life.
- Put your LifeBook notebook in Suspend mode when it is turned on and you are not actually using it.
- Limit your DVD/CD-RW/CD-ROM access.

- Disable the Windows CD Auto Insert function.
- Always use fully charged batteries.
- Eject PCMCIA cards when not in use.

FLOPPY DISKS AND DRIVES

Caring for your Floppy Disks

- Avoid using the floppy disks in damp and dusty locations.
- Never store a floppy disk near a magnet or magnetic field.
- Do not use a pencil or an eraser on a disk or disk label.
- Avoid storing the floppy disks in extremely hot or cold locations, or in locations subject to severe temperature changes. Store at temperatures between 50° F (10°C) and 125°F (52°C).
- Do not touch the exposed part of the disk behind the metal shutter.

Caring for your Floppy Disk Drive

- To clean, wipe the floppy disk drive clean with a dry soft cloth, or with a soft cloth dampened with water or a solution of neutral detergent. Never use benzene, paint thinner or other volatile material.
- Avoid storing the floppy disk drive in extremely hot or cold locations, or in locations subject to severe temperature changes. Store at temperatures between 50° F (10°C) and 125°F (52°C).
- Keep the floppy disk drive out of direct sunlight and away from heating equipment.
- Avoid storing the floppy disk drive in locations subject to shock and vibration.
- Never use the floppy disk drive with any liquid, metal, or other foreign matter inside the floppy disk drive or disk.
- Never disassemble or dismantle your floppy disk drive.

DVDs AND CDs

Caring for your DVDs and CDs

DVDs and CDs are precision devices and will function reliably if given reasonable care.

- Always store your DVD/CDs in its case when it is not in use.
- Always handle DVD/CDs by the edges and avoid touching the surface.
- Avoid storing any DVD/CDs in extreme temperatures.
- Do not bend DVD/CDs or set heavy objects on them.
- Do not spill liquids on DVD/CDs.
- Do not scratch DVD/CDs.

- Do not put a label on DVD/CDs.
- Do not get dust on DVD/CDs.
- Never write on the label surface with a ballpoint pen or pencil. Always use a felt pen.
- If a DVD/CD is subjected to a sudden change in temperature, cold to warm, condensation may form on the surface. Wipe the moisture off with a clean, soft, lint free cloth and let it dry at room temperature. DO NOT use a hair dryer or heater to dry DVD/CDs.
- If a DVD/CD is dirty, use only a DVD/CD cleaner or wipe it with a clean, soft, lint free cloth starting from the inner edge and wiping to the outer edge.

Caring for your Media Drive

Your media drive is durable but you must treat it with care. Please pay attention to the following points:

- The drive rotates the compact disk at a very high speed. Do not carry it around or subject it to shock or vibration with the power on.
- Avoid using or storing the drive where it will be exposed to extreme temperatures.
- Avoid using or storing the drive where it is damp or dusty.
- Avoid using or storing the drive near magnets or devices that generate strong magnetic fields.
- Avoid using or storing the drive where it will be subjected to shock or vibration.
- Do not disassemble or dismantle the DVD drive or CD-RW drive.

PC CARDS

Caring for your PC Cards

PC Cards are durable, but you must treat them with care. The documentation supplied with your PC Card will provide specific information, but you should pay attention to the following points:

- To keep out dust and dirt, store PC Cards in their protective sleeves when they are not installed in your LifeBook notebook.
- Avoid prolonged exposure to direct sunlight or excessive heat.
- Keep the cards dry.
- Do not flex or bend the cards, and do not place heavy objects on top of them.
- Do not force cards into the slot.
- Avoid dropping cards, or subjecting them to excessive vibration.



LifeBook E Series - Section 6

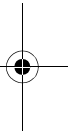
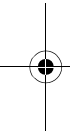

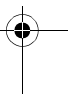
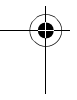

7 Specifications

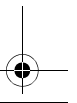
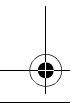
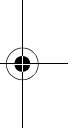
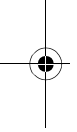

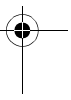
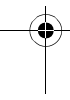

LifeBook E Series - Section 7

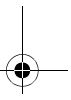
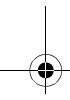
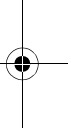
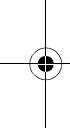

Specifications

Specifications

This section provides the general hardware and environmental specifications for your LifeBook notebook. Specific details about your system may vary from those referenced here. For an updated list of current configurations, please go to the Fujitsu PC Web site at: www.fujitsupc.com.

POINT

All options listed are accurate as of the date of print; substitutions may have been made subsequent to date of publication.

CONFIGURATION LABEL

Your LifeBook notebook contains a configuration label located on the bottom of the system (See Figure 2-8 on page 13 for location). This label contains specific information regarding the options you've chosen for your notebook. Following is an example label, and information about its various parts.

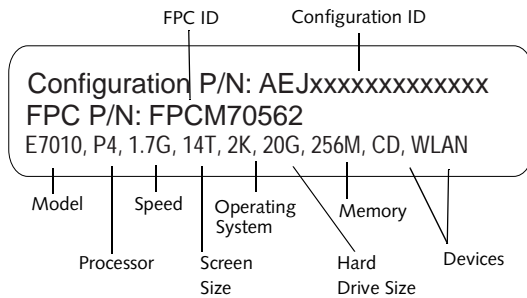

Figure 7-1 Configuration Label

MICROPROCESSOR

- Mobile Intel Pentium 4 Processor-M
- 1.8GHz, 1.7GHz, 1.6GHz

MEMORY

System Memory Range:
Upgradeable to 1GB, DDR266 (512MB x 2)
2 DIMM slots

Cache Memory
512K On-die L2

BIOS Memory
1MB Flash ROM
256 Bytes CMOS-RAM with back-up battery

VIDEO

Built-in color flat-panel XGA TFT active matrix LCD display with simultaneous display capability.

Video Color and Resolution

- Internal:
 - 14.1" XGA - 1024 x 768 pixel resolution, 16M colors
 - 15" SXGA+ - 1400 x 1050 pixel resolution, 64K colors

- External: 1600 x 1200 pixel resolution, 64K colors at 60Hz
- Simultaneous Video: 1024 x 768, 16M colors max, XGA, SVGA and VGA compatible

Graphics Accelerator Card

ATI® Rage® Mobility Radeon™ 7500 with 32MB Embedded DDR Video RAM

4x AGP supported

AUDIO

- AC97 Codec Sigmatel 9767
- Optical Digital Out (SPDIF)/stereo headphone jack, 1 Vrms or less, minimum impedance 32 Ohms
- Mono microphone jack, 100mVrms or less, minimum impedance 10K Ohms
- Two built-in stereo speakers, elliptical (~15 x 35 mm diameter)

MASS STORAGE DEVICE OPTIONS

Floppy Disk Drive

- External USB Floppy Disk Drive

Hard Disk Drive

20GB, 30GB, or 40GB, Ultra DMA 100

Media Drive

- Modular CD, or,
- Modular DVD drive, or,
- Modular DVD/CD-RW combo drive

FEATURES

Integrated Pointing Device:

- Touchpad
- Wireless Infrared Mouse

Depending upon the configuration of your system, you may also have:

LifeBook Security/Application Panel

Security Panel: 4-button security combination for both hardware and software.

One Touch Panel: 4-button application launcher for Internet, e-mail and software while your LifeBook notebook is On state. Your LifeBook Application Panel buttons are assigned the following defaults:

Button Label	Button Function	Default Application
1	Application A	Notepad
2	Application B	Calculator
3	Internet	Internet Explorer
4	E-Mail	Netscape Messenger/ Outlook Express

Table 7-1. Application Launcher Buttons

Theft Prevention Lock Slot

Lock slot for use with physical restraining security systems. The locking system by Kensington is recommended.

Communications

Integrated 10/100 base-Tx Ethernet LAN Internal V.90 standard 56K* fax/modem (ITU V.90, 56K data, 14.4K fax).

Optional: Integrated Wireless LAN (802.11b)** with On/Off button.

* Actual data transfer rate over U.S. telephone lines varies and is less than 56Kbps due to the current FCC regulations and line conditions.

** Operates at 2.4GHz; communications range may vary, depending upon surrounding environment.

DEVICE PORTS

- Combination PC Card slot for one Type III/two Type II cards: PCMCIA Standard 2.1 with CardBus support
- One 6-pin mini DIN PS/2 compatible connector, for external keyboard, external mouse or external numeric keypad
- Embedded Smart Card Reader (requires optional Smart Card holder)
- One 25-pin D-SUB two-way Centronics type connector for parallel input/output devices; Bi-directional, output only or ECP
- One 120-pin connector for docking devices.
- One 15-pin D-SUB connector for VGA external monitor (see Display specifications)
- One 9-pin D-SUB connector for RS-232C serial input/output devices
- One IEEE 1394 (4-pin) port
- One S-Video Out port
- Two connectors for USB (Universal Serial Bus) input/output devices
- IR Receiver for Fujitsu wireless mouse
- Fast IR (up to 4 Mbps) compatible infrared port for wireless data transfer
- One Optical Digital Out (SPDIF)/stereo headphone jack (See Audio specifications)
- One mono microphone jack (See Audio specifications)
- One modular modem (RJ-11) connector
- One modular LAN (RJ-45) connector

KEYBOARD

Built-in keyboard with all functions of 87 key PS/2 compatible keyboards.

- Total number of keys: 87
- Function keys: 12, [F1] through [F12]
- Feature extension key: [Fn]
- Windows keys: 3, two Start keys and an application key

- Key pitch: 19 mm
- Key stroke: 2.7 mm
- Built-in Touchpad pointing device with left and right buttons

External Keyboard Support

- PS/2-compatible
- USB-compatible

External Numeric Keypad Support

- PS/2-compatible
- USB-compatible

External Mouse Support

- PS/2-compatible
- USB-compatible

Management Standard

DMI 2.0-ready, WFM 2.0-compliant (LAN models only)

POWER**Batteries**

Main 8-cell Lithium ion battery, rechargeable, 14.4V, 3800 mAh

Option: Second 6-cell Lithium ion battery, rechargeable, 10.8V, 3400 mAh (for Flexible Bay installation)

Adapters

AC Adapter: Autosensing 100-240V AC, 80W, supplying 19V DC, 4.22A, to the LifeBook notebook, Fujitsu Model FPCAC33AP, which includes an AC cable.

Option: Auto/Airline Adapter: Converts the DC voltage from an automobile cigarette lighter or aircraft DC power outlet to the DC voltage needed to power your notebook.

Power Management

Conforms to ACPI (Advanced Configuration & Power Interface)

Electrostatic Discharge (ESD)

9 kV

DIMENSIONS**Overall Dimensions**

12.13" x 10.39" x 1.28" (308 mm x 264 mm x 32.5 mm)

ENVIRONMENTAL REQUIREMENTS**Temperature**

Operating: 5° to 35° C (41° to 95° F)

Non-operating: -15° to 60° C (5° to 140° F)

Humidity

Operating: 20% to 85%, relative, non-condensing.

Non-operating: 8% to 85%, relative, non-condensing

Altitude

Operating: 10,000 feet (3,048 m) maximum

Specifications**POPULAR ACCESSORIES**

For ordering or additional information on Fujitsu accessories please visit our Web site at: www.fujitsupc.com or call 1-800-733-0884.

Memory Upgrades

PC2100 DDR266 Memory Modules:

- 128MB
- 256MB
- 512MB

Docking

- Port Replicator

Expansions

- External USB floppy disk drive

Power

- Additional main Lithium ion battery
- Modular Lithium ion battery
- Auto/Airline Adapter
- Additional AC Adapter

Flexible Bay Devices

- Modular CD-ROM drive
- Modular DVD-ROM drive
- Modular DVD/CD-RW combo drive
- Modular Lithium ion battery (for Flexible Bay installation)

Additional Accessories

- Wireless Infrared (IR) Mouse
- Wireless Keyboard and Mouse
- Numeric Keypad
- Presentation Audio System
- MindPath PocketPoint
- TeleAdapt 16' TeleCord
- Notebook Guardian Lock
- IBM Modem Saver
- Monitor Stand

Carrying Cases

- Diplomat
- ProPack Backpack
- Executive Plus

PRE-INSTALLED SOFTWARE

Software Application (Vendor)	Windows 2000	Windows 98 SE	Windows XP Home	Windows XP Pro
Adobe Acrobat Reader	X*	X*	X*	X*
Fujitsu BatteryAid/HotKey Utility	X	X	X	X
Fujitsu Service Assistant	**	**	**	**
Softex BayManager		X		
PowerQuest Drive Image Special Edition	X	X***	X	X
LifeBook Application Panel Software	X	X	X	X
Security Application Panel Software	X	X	X	X
McAfee.com Scan for Virus	*	*	X	X
Earthlink			X	*
Netscape 6	*	*	*	*
Quicken 2002 New User Edition			X	
Intel SpeedStep	X	X		

* This software is located on CDs, as noted below.

** The installer is pre-loaded; the full version is included on the Fujitsu Service Assistant CD.

*** Systems with Windows 98 have the DISE files included on the hard disk drive. (See *Installing and Using DISE With Windows 98 Systems on page 73 for more information*).

CD-BASED SOFTWARE

In the following table, "DAR" stands for "Drivers and Applications Restore CD".

Software Application (Vendor)	Windows 2000	Windows 98 SE	Windows XP Home	Windows XP Pro
Adobe Acrobat Reader (updated version)	DAR	DAR	DAR	DAR
Fujitsu Service Assistant (separate CD)	CD	CD	--	CD
McAfee.com Scan for Virus	DAR	DAR	DAR	DAR
Netscape 6	DAR	DAR	DAR	DAR
Earthlink	DAR	DAR	DAR	DAR
PowerQuest Drive Image Special Edition	--	DAR	--	--

Your Fujitsu LifeBook notebook comes with pre-installed software for playing audio and video files of various formats. The software configuration installed is dependent upon the operating system that is pre-installed on your system. (Refer to Table 7-2.) In addition, there is file transfer software, virus protection software and Power Management software.

Software vendors occasionally update their software packages. To ensure that you are using the optimal version for your LifeBook in the future, visit the software company web sites periodically.

Manuals

Included with your LifeBook notebook you will find manuals for your operating system and other pre-installed software. Manuals that are not included are available online through the help system of the software.

We recommend that you review these manuals for general information on the use of these applications.

Tutorials

All operating systems and most application software have tutorials built-into them upon installation. We highly recommend that you step through the tutorial before you use an application.

APPLICATION DESCRIPTIONS

Adobe Acrobat Reader

The Adobe Acrobat Reader allows you to view, navigate, and print PDF files from across all of the major computing platforms.

Fujitsu BatteryAid (Windows 98 and 2000)/ HotKey (Windows XP)

Fujitsu BatteryAid allows you to optimize system power by monitoring and managing battery status. Fujitsu HotKey allows you to monitor and manage the status of the screen brightness and system volume. (See your *BatteryAid online help for more information on the correct way to use this program*)

POINT

As your notebook does not support the CPU Clock control, the option is not active within the Power Control menu of BatteryAid.

Softex BayManager (Windows 98)

BayManager provides a simple and powerful method of switching drives of a LifeBook notebook computer without having to reboot the computer. Windows 98 Second Edition does not natively support hot swapping. With BayManager, you can swap bay devices while your OS is running, this is called hot-swapping.

BayManager Features

- Allows hot-swapping of devices on your LifeBook notebook. You do not need to shut down the system to exchange devices.
- Works under Windows 98 Second Edition.
- Works under ACPI and APM.
- Provides power management integrity for devices that enter and leave the system.

Drive Image Special Edition (DISE) by PowerQuest

DISE by PowerQuest provides a way to restore your computer if you experience a hard disk crash or other system failure. DISE is used to restore the factory image and restore the system to its original state. Note that on systems with Windows 98 installed, the DISE directory structure is in place, but the drive image and DISE software have not yet been installed. (See *Drive Image Special Edition (DISE) on page 72 for more information*)

Intel SpeedStep (Windows 98 and 2000)

Intel SpeedStep allows your Lifebook to operate in dual mode. When connected to AC source, the system operates in Maximum Performance mode. When powered by battery, the system switches to Battery Optimized mode to conserve battery life. SpeedStep software is automatically loaded when you start your system and appears on the system tray as flags in one of two modes: (1) A checker flag indicates that the system is set for

Maximum Performance mode. (2) A blue flag with a green center square indicates that the system is set for Battery Optimized mode. You can change the setting or disable the software by double-clicking the flag icon and changing the settings in the Intel SpeedStep Technology window.

LifeBook Application Panel Software

Your LifeBook notebook is pre-installed with software utilities that let you operate and configure your LifeBook Application Panel. These utilities are found under the Start menu, under Programs, then under LifeBook Application Panel. They include a CD Player, Application Panel Setup, Application Panel Guide, Activate Panel, Deactivate Panel and E-mail LED Setup.

LifeBook Security Panel Software

LifeBook Security Panel allows you to secure your LifeBook notebook from unauthorized use. If the security system is activated, upon starting your LifeBook notebook or resuming from Suspend mode the security system requires you to enter a password code using the buttons on the 5-button Security Panel. After entering a correct password, your LifeBook notebook resumes system operation.

McAfee.com Scan for Virus

Scan for Virus, by McAfee.com, is a web-based antivirus program that can be run from the McAfee.com website after loading data or programs onto your LifeBook notebook. It assists in the protection of the data currently residing on your hard disk from destruction or contamination due to computer virus. (See your *online help, or go to the McAfee web site at: <http://www.mcafee.com> for more information on how and when to run this program*)

Netscape 6

Netscape 6 provides a suite of Internet tools.

Quicken 2002 New User Edition

Quicken 2002 by Intuit is a personal money management program. It has features such as portfolio management, account registries, on-line banking and bill paying features.

Fujitsu Service Assistant

The Fujitsu Service Assistant is an interactive support tool that provides automated diagnosis and solutions for your hardware and software problems. The Fujitsu Service Assistant has the ability to automatically detect new messages when online. This tool is located in one or both of the following locations:

- A Fujitsu Service Assistant icon on your desktop
- In the Start -> Service and Support folder.

New support information for the Fujitsu Service Assistant tool may be available after the purchase of your notebook. To receive the most up-to-date information, please connect to the Internet prior to using the Fujitsu

LifeBook E Series - Section 7

Service Assistant tool for the first time. We recommend that you periodically connect to the Internet while using the Fujitsu Service Assistant tool.

You may occasionally receive an "Administrative Rights" message. The network test is designed to test the configuration of your network card and determine your network connection status. Due to the security features built into the Windows 2000 operating system, only users with Administrator level access are able to run this particular test. Please consult your network administrator for further assistance with this issue.

For further information about the Fujitsu Service Assistant, call 1-800-Fujitsu (1-800-838-5487), or visit the FPC support website at: www.fujitsupc.com/support.

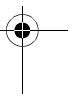
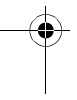

8 Glossary

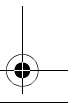
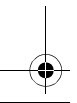
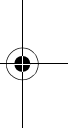
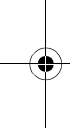

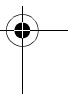
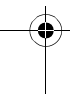

LifeBook E Series - Section 8

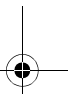
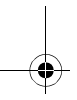
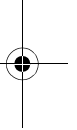
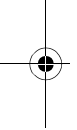

Glossary

AC Adapter

A device which converts the AC voltage from a wall outlet to the DC voltage needed to power your LifeBook notebook.

ACPI

Advanced Configuration & Power Interface. A power management tool, which is part of the Windows 98 Second Edition operating system, that enables the operating system to control the amount of power given to each device attached to the computer. With ACPI, the operating system can turn off peripheral devices, such as the CD-ROM player, when it is not in use.

Active-Matrix Display

A type of technology for making flat-panel displays which has a transistor or similar device for every pixel on the screen.

Auto/Airline Adapter

A device which converts the DC voltage from an automobile cigarette lighter or aircraft DC power outlet to the DC voltage needed to power your LifeBook notebook.

BatteryAid

Utility that allows the user to change the display brightness in order to optimize battery life.

BIOS

Basic Input-Output System. A program and set of default parameters stored in ROM which tests and operates your LifeBook notebook when you turn it on until it loads your installed operating system from disk. Information from the BIOS is transferred to the installed operating system to provide it with information on the configuration and status of the hardware.

Bit

An abbreviation for binary digit. A single piece of information which is either a one (1) or a zero (0).

bps

An abbreviation for bits per second. Used to describe data transfer rates.

Boot

To start-up a computer and load its operating system from disk, ROM or other storage media into RAM.

Bus

An electrical circuit which passes data between the CPU and the sub-assemblies inside your LifeBook notebook.

Byte

8 bits of parallel binary information.

Cache Memory

A block of memory built into the microprocessor which is much faster to access than your system RAM and used in specially structured ways to make your overall data handling time faster.

CardBus

A faster, 32-bit version of the PC Card interface which offers performance similar to the 32-bit PCI architecture.

CMOS RAM

Complementary metal oxide semiconductor random access memory. This is a technology for manufacturing random access memory which requires very low levels of power to operate.

COMM Port

Abbreviation for communication port. This is your serial interface connection.

Command

An instruction which you give your operating system. Example: run a particular application or format a floppy disk.

Configuration

The combination of hardware and software that makes up your system and how it is allocated for use.

CRT

Cathode Ray Tube. A display device which uses a beam of electronic particles striking a luminescent screen. It produces a visual image by varying the position and intensity of the beam.

Data

The information a system stores and processes.

DC

Direct current. A voltage or current that does not fluctuate periodically with time.

DDR

Double Data Rate

Fast version of SDRAM that provides twice the bandwidth of standard SDRAMs.

Default Value

A pre-programmed value to be used if you fail to set your own.

DIMM

Dual-in-line memory module.

DISE

Drive Image Special Edition (DISE) by PowerQuest. Provides a way to restore your computer if you experience a hard disk crash or other system failure. DISE is used to restore the factory image and restore the system to its original state.

Disk

A spinning platter of magnetic data storage media. If the platter is very stiff it is a hard drive, if it is highly flexible it is a floppy disk, if it is a floppy disk in a hard housing with a shutter it is commonly called a diskette.

Disk Drive

The hardware which spins the disk and has the heads and control circuitry for reading and writing the data on the disk.

Diskette

A floppy disk in a hard housing with a shutter.

DMA

Direct Memory Access. Special circuitry for memory to memory transfers of data which do not require CPU action.

DMI

Desktop Management Interface. A standard that provides PC management applications with a common method of locally or remotely querying and configuring PC computer systems, hardware and software components, and peripherals.

DOS

Disk Operating System (MS-DOS is a Microsoft Disk Operating System).

Driver

A computer program which converts application and operating system commands to external devices into the exact form required by a specific brand and model of device in order to produce the desired results from that particular equipment.

DVD

Digital Video Disc. This is a form of optical disc storage for video, audio and computer data, envisioned to replace current digital storage formats (CD-ROM, laser and audio CD) because of its capability for storing

greater amounts of data. A typical single layer, single-sided DVD, for example, can contain 4.7GB of data and a maximum of 17GB for the double-sided discs.

ECP

Extended Capability Port. A set of standards for high speed data communication and interconnection between electronic devices.

ESD

Electrostatic Discharge. The sudden discharge of electricity from a static charge which has built-up slowly. Example: the shock you get from a doorknob on a dry day or the sparks you get from brushing hair on a dry day.

Extended Memory

All memory more than the 640KB recognized by MS-DOS as system memory.

FCC

Federal Communication Commission.

Floppy Disk

A spinning platter of magnetic data storage media which is highly flexible.

GB

Gigabyte.

Hard drive

A spinning platter of magnetic data storage media where the platter is very stiff.

Hexadecimal

A decimal notation for the value of a 4 bit binary number. (0-9, A, B, C, D, E, F) Example: 2F in hexadecimal = 00101111 in binary = 47 in decimal.

I/O

Input/Output. Data entering and leaving your LifeBook notebook in electronic form.

I/O Port

The connector and associated control circuits for data entering and leaving your LifeBook notebook in electronic form.

IDE

Intelligent Drive Electronics. A type of control interface for a hard drive which is inside the hard drive unit.

IEEE 1394

A type of data transfer protocol that allows for fast transfer of digital files and data with devices such as digital cameras.

Infrared

Light just beyond the red portion of the visible light spectrum which is invisible to humans.

IR

An abbreviation for infrared.

IrDA

Infrared Data Association. An organization which produces standards for communication using infrared as the carrier.

IRQ

Interrupt Request. An acronym for the hardware signal to the CPU that an external event has occurred which needs to be processed.

KB

Kilobyte.

LAN

Local Area Network. An interconnection of computers and peripherals within a single limited geographic location which can pass programs and data amongst themselves.

LCD

Liquid Crystal Display. A type of display which makes images by controlling the orientation of crystals in a crystalline liquid.

Lithium ion Battery

A type of rechargeable battery which has a high power-time life for its size and is not subject to the memory effect as Nickel Cadmium batteries.

LPT Port

Line Printer Port. A way of referring to parallel interface ports because historically line printers were the first and latter the most common device connected to parallel ports.

MB

Megabyte.

Megahertz

1,000,000 cycles per second.

Memory

A repository for data and applications which is readily accessible to your LifeBook notebook's CPU.

MHz

Megahertz.

MIDI

Musical Instrument Digital Interface. A standard communication protocol for exchange of information between computers and sound producers such as synthesizers.

Modem

A contraction for MODulator-DEModulator. The equipment which connects a computer or other data terminal to a communication line.

Monoaural

A system using one channel to process sound from all sources.

MPU-401

A standard for MIDI interfaces and connectors.

NTSC

National TV Standards Commission. The standard for TV broadcast and reception for the USA.

Operating System

A group of control programs that convert application commands, including driver programs, into the exact form required by a specific brand and model of micro-processor in order to produce the desired results from that particular equipment.

Parallel Port

A connection to another device through which data is transferred as a block of bits simultaneously with a wire for each bit in the block and with other wires only for control of the device not for transfer of data.

Partition

A block of space on a hard drive which is set aside and made to appear to the operating system as if it were a separate disk, and addressed by the operating system accordingly.

PCMCIA

PCMCIA is a trademark of the Personal Computer Memory Card International Association. The Personal Computer Memory Card International Association is an organization that sets standards for add-in cards for personal computers.

Peripheral Device

A piece of equipment which performs a specific function associated with but not integral to a computer. Examples: a printer, a modem, a CD-ROM.

Pitch (keyboard)

The distance between the centers of the letter keys of a keyboard.

Pixel

The smallest element of a display, a dot of color on your display screen. The more pixels per area the clearer your image will appear.

POST

Power On Self Test. A program which is part of the BIOS which checks the configuration and operating condition of your hardware whenever power is applied to your LifeBook notebook. Status and error messages may be displayed before the operating system is loaded. If the self test detects failures that are so serious that operation can not continue, the operating system will not be loaded.

Program

An integrated set of coded commands to your computers telling your hardware what to do and how and when to do it.

PS/2

An IBM series of personal computers which established a number of standards for connecting external devices such as keyboards and monitors.

RAM

Random Access Memory. A hardware component of your LifeBook notebook that holds binary information (both program and data) as long as it has the proper power applied to it.

RAM Module

A printed circuit card with memory and associated circuitry which allows the user to add additional memory to the computer without special tools.

Reset

The act of reloading the operating system. A reset erases all information stored in RAM.

Restart

See Reset.

Resume

To proceed after interruption. In your LifeBook notebook this refers to returning to active operation after having been in one of the suspension states.

ROM

Read Only Memory. A form of memory in which information is stored by physically altering the material. Data

stored in this way can not be changed by your LifeBook notebook and does not require power to maintain it.

SDRAM

Synchronous Dynamic Random Access Memory.

Serial Port

A connection to another device through which data is transferred one bit at a time on a single wire with any other wires only for control of the device not for transfer of data.

Shadow RAM

A technique of copying data or applications stored in ROM (Read Only Memory) into RAM (Random Access Memory) for access during actual operation. RAM is much faster to access than ROM, however ROM contents are not lost when power is removed. Shadowing allows permanently stored information to be rapidly accessed.

Smart Card

Smart Cards are the same size and shape as credit cards, but they contain an integrated microprocessor chip. The chip can hold a variety of different information, and provides the user with many possible options, such as allowing them to make secure purchases, pay for phone calls, store security information, and provide personal identification and information.

SRAM

Static Random Access Memory. A specific technology of making RAM which does not require periodic data refreshing.

Status Indicator

A display which reports the condition of some portion of your hardware. On your LifeBook notebook this is an LCD screen just above the keyboard.

Stereo (audio)

A system using two channels to process sound from two different sources.

Stroke (keyboard)

The amount of travel of a key when it is pressed from resting to fully depressed.

Suspend

To make inoperative for a period of time. Your LifeBook notebook uses various suspension states to reduce power consumption and prolong the charge of your battery.

SVGA

Super VGA.

Glossary**S-Video**

Super Video. A component video system for driving a TV or computer monitor.

System Clock

An oscillator of fixed precise frequency which synchronizes the operation of the system and is counted to provide time of day and date.

TFT

Thin Film Transistor – A technology for flat display panels which uses a thin film matrix of transistors to control each pixel of the display screen individually.

UL

Underwriters Laboratories – An independent organization that tests and certifies the electrical safety of devices.

VGA

Video Graphics Array. A video display standard originally introduced by IBM with the PS/2 series of personal computers.

VRAM

Video Random Access Memory. A memory dedicated to video display data and control.

WFM

Wired for Management is Intel's broad-based initiative to reduce the total cost of ownership (TCO) of business computing without sacrificing power and flexibility.

Write Protect

Prevent alteration of the binary state of all bits in a storage media. Example: all information on a device such as a floppy diskette; a block of space in a storage media such as a partition of a hard drive; a file or directory of floppy diskette or hard drive.

XGA

Extended VGA.

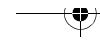

LifeBook E Series

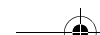
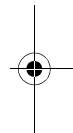
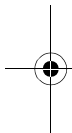

Regulatory Information

NOTICE

Changes or modifications not expressly approved by Fujitsu could void this user's authority to operate the equipment.

FCC NOTICES

Notice to Users of Radios and Television

These limits are designed to provide reasonable protection against harmful interference in a residential installation. This equipment generates, uses, and can radiate radio frequency energy and, if not installed and used in accordance with the instructions, may cause harmful interference to radio communications. However, there is no guarantee that interference will not occur in a particular installation. If this equipment does cause harmful interference to radio or television reception, which can be determined by turning the equipment off and on, the user is encouraged to try to correct the interference by one or more of the following measures:

- Reorient or relocate the receiving antenna.
- Increase the separation between the equipment and receiver.
- Connect the equipment into an outlet that is on a different circuit than the receiver.
- Consult the dealer or an experienced radio/TV technician for help.

Shielded interconnect cables must be employed with this equipment to ensure compliance with the pertinent RF emission limits governing this device.

Notice to Users of the US Telephone Network

Your LifeBook notebook may be supplied with an internal modem which complies with Part 68 of the FCC rules. On this LifeBook notebook is a label that contains the FCC Registration Number and the Ringer Equivalence Number (REN) for this equipment among other information. If requested, the user must provide their telephone company with the following information:

1. The telephone number to which the LifeBook notebook is connected.
2. The Ringer Equivalence Number (REN) for this equipment.
3. The equipment requires a standard modular jack type USOC RJ-11C which is FCC Part 68 compliant.
4. The FCC Registration Number.

This equipment is designed to be connected to the telephone network or premises wiring using a standard modular jack type USOC RJ-11C which is FCC Part 68 compliant and a line cord between the modem and the telephone network with a minimum of 26AWG.

The REN is used to determine the number of devices that you may connect to your telephone line and still

have all of those devices ring when your number is called. Too many devices on one line may result in failure to ring in response to an incoming call. In most, but not all, areas the sum of the RENs of all of the devices should not exceed five (5). To be certain of the number of devices you may connect to your line, as determined by the RENs, contact your local telephone company.

If this equipment causes harm to the telephone network, your telephone company may discontinue your service temporarily. If possible, they will notify you in advance. If advance notice is not practical they will notify you as soon as possible. You will also be advised of your right to file a complaint with the FCC.

This fax modem also complies with fax branding requirements per FCC Part 68.

Your telephone company will probably ask you to disconnect this equipment from the telephone network until the problem is corrected and you are sure that the equipment is not malfunctioning. This equipment may not be used on coin-operated telephones provided by your telephone company. Connection to party lines is subject to state tariffs. Contact your state's public utility commission, public service commission or corporation commission for more information.

This equipment includes automatic dialing capability. When programming and/or making test calls to emergency numbers:

- Remain on the line and briefly explain to the dispatcher the reason for the call.
- Perform such activities in off-peak hours, such as early morning or late evening.

FCC rules prohibit the use of non-hearing aid compatible telephones in the following locations or applications:

- All public or semipublic coin-operated or credit card telephones.
- Elevators, highways, tunnels (automobile, subway, railroad or pedestrian) where a person with impaired hearing might be isolated in an emergency.
- Places where telephones are specifically installed to alert emergency authorities such as fire, police or medical assistance personnel.
- Hospital rooms, residential health care facilities, convalescent homes and prisons.
- Hotel, motel or apartment lobbies.
- Stores where telephones are used by patrons to order merchandise.
- Public transportation terminals where telephones are used to call taxis or to reserve lodging or rental cars.
- In hotel and motel rooms as at least ten percent of the rooms must contain hearing aid-compatible telephones or jacks for plug-in hearing aid compatible telephones which will be provided to hearing impaired customers on request.

DOC (INDUSTRY CANADA) NOTICES**Notice to Users of Radios and Television**

This Class B digital apparatus meets all requirements of Canadian Interference-Causing Equipment Regulations.

CET appareil numérique de la class B respecte toutes les exigences du Règlement sur le matériel brouilleur du Canada.

Notice to Users of the Canadian Telephone Network

NOTICE: This equipment meets the applicable Industry Canada Terminal Equipment Technical Specifications. This is confirmed by the registration number. The abbreviation, IC, before the registration number signifies that registration was performed based on a Declaration of Conformity indicating that Industry Canada technical specifications were met. It does not imply that Industry Canada approved the equipment.

Before connecting this equipment to a telephone line the user should ensure that it is permissible to connect this equipment to the local telecommunication facilities. The user should be aware that compliance with the certification standards does not prevent service degradation in some situations.

Repairs to telecommunication equipment should be made by a Canadian authorized maintenance facility. Any repairs or alterations not expressly approved by Fujitsu or any equipment failures may give the telecommunication company cause to request the user to disconnect the equipment from the telephone line.

NOTICE: The Ringer Equivalence Number (REN) for this terminal equipment is 0.0. The REN assigned to each terminal equipment provides an indication of the maximum number of terminals allowed to be connected to a telephone interface. The termination on an interface may consist of any combination of devices subject only to the requirement that the sum of the Ringer Equivalence Numbers of all the devices does not exceed five.

**CAUTION**

For safety, users should ensure that the electrical ground of the power utility, the telephone lines and the metallic water pipes are connected together. Users should NOT attempt to make such connections themselves but should contact the appropriate electric inspection authority or electrician. This may be particularly important in rural areas.

Avis Aux Utilisateurs Du Réseau Téléphonique Canadien

AVIS: Le présent matériel est conforme aux spécifications techniques d'Industrie Canada applicables au matériel terminal. Cette conformité est confirmée par le numéro d'enregistrement. Le sigle IC, placé devant le numéro d'enregistrement, signifie que l'enregistrement s'est effectué conformément à une déclaration de conformité et indique que les spécifications techniques d'Industrie Canada ont été respectées. Il n'implique pas qu'Industrie Canada a approuvé le matériel.

Avant de connecter cet équipement à une ligne téléphonique, l'utilisateur doit vérifier s'il est permis de connecter cet équipement aux installations de télécommunications locales. L'utilisateur est averti que même la conformité aux normes de certification ne peut dans certains cas empêcher la dégradation du service.

Les réparations de l'équipement de télécommunications doivent être effectuées par un service de maintenance agréé au Canada. Toute réparation ou modification, qui n'est pas expressément approuvée par Fujitsu, ou toute défaillance de l'équipement peut entraîner la compagnie de télécommunications à exiger que l'utilisateur déconnecte l'équipement de la ligne téléphonique.

AVIS: L'indice d'équivalence de la sonnerie (IES) du présent matériel est de 0.0. L'IES assigné à chaque dispositif terminal indique le nombre maximal de terminaux qui peuvent être raccordés à une interface téléphonique. La terminaison d'une interface peut consister en une combinaison quelconque de dispositifs, à la seule condition que la somme d'indices d'équivalence de la sonnerie de tous les dispositifs n'excède pas 5.

**AVERTISSEMENT**

Pour assurer la sécurité, les utilisateurs doivent vérifier que la prise de terre du service d'électricité, les lignes téléphoniques et les conduites d'eau métalliques sont connectées ensemble. Les utilisateurs NE doivent PAS tenter d'établir ces connexions eux-mêmes, mais doivent contacter les services d'inspection d'installations électriques appropriés ou un électricien. Ceci peut être particulièrement important en régions rurales.

Regulatory Information

UL Notice

This unit requires an AC adapter to operate. Use only UL Listed Class 2 adapter, output rating 19V DC, 4.22 A. Refer to the illustration below for the correct AC Adapter output polarity:



 **CAUTION**

To reduce the risk of fire, use only #26 AWG or larger telecommunications line cord.

For Authorized Repair Technicians Only

 **CAUTION**

For continued protection against risk of fire, replace only with the same type and rating fuse.

 **WARNING**

Danger of explosion if Lithium (CMOS) battery is incorrectly replaced. Replace only with the same or equivalent type recommended by the manufacturer. Dispose of used batteries according to the manufacturer's instruction.

LifeBook E Series



Appendix

Integrated Wireless LAN User's Guide

LifeBook E Series - Appendix

FC FCC REGULATORY INFORMATION

Please note the following regulatory information related to your wireless LAN device.

Regulatory Notes and Statements

Wireless LAN, Health and Authorization for use

Radio frequency electromagnetic energy is emitted from Wireless LAN devices. The energy levels of these emissions, however, are far much less than the electromagnetic energy emissions from wireless devices such as mobile phones. Wireless LAN devices are safe for use by consumers because they operate within the guidelines found in radio frequency safety standards and recommendations. The use of Wireless LAN devices may be restricted in some situations or environments, such as:

- On board an airplane, or
- In an explosive environment, or
- In situations where the interference risk to other devices or services is perceived or identified as harmful.

In cases in which the policy regarding use of Wireless LAN devices in specific environments is not clear (e.g., airports, hospitals, chemical/oil/gas industrial plants, private buildings), obtain authorization to use these devices prior to operating the equipment.

Regulatory Information/Disclaimers

Installation and use of this Wireless LAN device must be in strict accordance with the instructions included in the user documentation provided with the product. Any changes or modifications made to this device that are not expressly approved by the manufacturer may void the user's authority to operate the equipment. The Manufacturer is not responsible for any radio or television interference caused by unauthorized modification of this device, or the substitution or attachment of connecting cables and equipment other than those specified by the manufacturer. It is the responsibility of the user to correct any interference caused by such unauthorized modification, substitution or attachment. The Manufacturer and its authorized resellers or distributors will assume no liability for any damage or violation of government regulations arising from failure to comply with these guidelines.

Federal Communications Commission statement

This device complies with Part 15 of FCC Rules.

Operation is subject to the following two conditions: (1) This device may not cause interference, and, (2) This device must accept any interference, including interference that may cause undesired operation of this device.

FCC Interference Statement

This equipment has been tested and found to comply with the limits for a Class B digital device, pursuant to Part 15 of the FCC Rules. These limits are designed to provide reasonable protection against harmful interference in a residential installation. This equipment generates, uses, and can radiate radio frequency energy. If not installed and used in accordance with the instructions, it may cause harmful interference to radio communications. However, there is no guarantee that interference will not occur in a particular installation.

If this equipment does cause harmful interference to radio or television reception, which can be determined by turning the equipment off and on, the user is encouraged to try and correct the interference by one or more of the following measures:

1. Reorient or relocate the receiving antenna.
2. Increase the distance between the equipment and the receiver.
3. Connect the equipment to an outlet on a circuit different from the one the receiver is connected to.
4. Consult the dealer or an experienced radio/TV technician for help.

FCC Radio Frequency Exposure statement

This Wireless LAN radio device has been evaluated under FCC Bulletin OET 65C and found compliant with the requirements as set forth in CFR 47 Sections 2.1091, 2.1093, and 15.247 (b) (4) addressing RF Exposure from radio frequency devices. The radiated output power of this Wireless LAN device is far below the FCC radio frequency exposure limits. Nevertheless, this device shall be used in such a manner that the potential for human contact during normal operation is minimized. When using this device, a certain separation distance between antenna and nearby persons must be maintained to ensure RF exposure compliance. In order to comply with RF exposure limits established in the ANSI C95.1 standards, the distance between the antennas and the user should not be less than 20 cm (8 inches).

Export restrictions

This product or software contains encryption code which may not be exported or transferred from the US or Canada without an approved US Department of Commerce export license. This device complies with Part 15 of FCC Rules., as well as ICES 003 B / NMB 003 B. Operation is subject to the following two conditions: (1) this device may not cause harmful interference, and (2) this device must accept any interference received, including interference that may cause undesirable operation. Modifications not expressly authorized by Fujitsu PC Corporation may invalidate the user's right to operate this equipment.

BEFORE USING THIS DEVICE

Thank you for purchasing a Fujitsu LifeBook with an Integrated Wireless LAN. This manual describes the basic operating procedures for the Wireless LAN (referred to as the “device” in this manual) and how to set up a wireless LAN network. Before using this device, read this manual carefully to ensure correct operation of the device. Keep this manual in a safe place for reference while using the device.

Characteristics of the Device

This device consists of a wireless LAN card that is attached to the computer via a mini-PCI slot.

The main characteristics are as follows:

- It uses the power saving communications system in the 2.4 GHz band, and does not require any license for radio communication.
- It uses Direct Sequence Spread Spectrum (DS-SS), which is resistant to noise.
- This device complies with Wi-Fi, and is able to communicate at the maximum transfer rate of 11 Mbps.
- The maximum communication range is approximately 80 feet (25 meters) inside a building. The range may be shorter depending upon the installation factors, such as walls and columns.
- Unauthorized access can be prevented with the use of SSID and encryption key.

Wireless LAN Modes Using this Device

AdHoc Mode

The “AdHoc Mode” refers to the network connecting two computers using wireless LAN cards. This connection is called an “AdHoc network.”

Using an AdHoc network, you can obtain a network connection easily and at a low cost.

In the AdHoc mode, you can use the function supported by Microsoft Network, such as File and Print Sharing to exchange files and share a printer or other peripheral devices.

To use the AdHoc Mode, you must set the same SSID and the same encryption key for all the computers that are connected. All connected computers can communicate with each other within the communication range.

Infrastructure Mode

If a number of computers are connected simultaneously in the AdHoc mode, the transfer rate may be reduced, communications may become unstable, or the network connection could fail. This is because all wireless LAN cards are using the same radio frequency in the network.

To improve this situation, you can use a wireless LAN access point, which is sold separately. The wireless LAN network is in the “Infrastructure mode” when it uses an access point, and such a connection is called the “Infrastructure Network.”

By using an access point, you can set and use a different communication channel for each network group. Each channel is given a different radio frequency, and it eliminates the collision of communications and provides a more stable communications environment. Infrastructure mode is most suitable when you are configuring multiple wireless LAN networks on the same floor.

To connect a wireless LAN network to a wired LAN, you need an access point.

How to Handle This Device

The Integrated Wireless LAN device is already installed in your LifeBook computer. Under normal circumstances, it should not be necessary for you to remove or re-install it. The LAN has been configured to support the operating system with which your system shipped.

CONNECTING WINDOWS 98/2000 SYSTEMS

This chapter describes how to set the wireless LAN connection for computers running Windows 98 or Windows 2000.



POINT

When you receive your LifeBook, the integrated wireless LAN device and drivers have already been installed. This procedure outlines the steps for setting the device parameters.

Updated drivers and/or utilities may become available after this manual is printed; see any addenda or fliers that may be included in the system packaging or visit our web site at: www.fujitsupc.com for the latest drivers..

Workflow

The proper setup of the wireless LAN requires several steps which must be performed in the proper order. Following is a general outline of the steps that must be performed. Each step is detailed later in this procedure.

1. Setting parameters
 - Setting the profile
 - Setting the encryption
2. Network settings
 - Setting the protocol and checking the network
 - Setting file and printer sharing
 - Checking the connection

Setting Parameters

1. Click [Start] -> [Settings] -> [Control Panel].
2. Double-click the [PRISM Settings] icon. The [PRISM Wireless Settings] appears.
3. Set the profile as specified in Table 1. Ask your network administrators to check the setting.
4. When you finish your entry, click [Apply].

Item	Description
Profile	Enter the system file name in which the parameter information is to be saved.
Mode	<i>Ad Hoc Network:</i> Click the down arrow and select "802.11 AdHoc". <i>Infrastructure Network:</i> Click the down arrow and select "Infrastructure".
SSID	Enter the network name to which you want to connect

Item	Description
Transmit Rate	Obtain the information from your network administrator. If you do not have a network administrator, select "Fully Automatic".
Power Save Enabled	Not supported.
AdHoc Channel	<i>AdHoc Network:</i> Select the same channel, 1-11, for all connected computers. If there is more than one wireless LAN nearby (such as on the same floor), we recommend that the channels for each LAN be 5 numbers apart (e.g., if there are two other LANs nearby, the channels used should be 1, 6, and 11). <i>Infrastructure Network:</i> Not an option.

Table 1: Profile Parameters

5. Click the [Encryption] tab.
6. Set the encryption items in accordance with Table 2.
 - *AdHoc Network:* Specify the same value for all the computers for which the encryption key is used for connection.
 - *Infrastructure Network:* Specify the identical encryption keys to the encryption keys set for the access point. For instructions on how to check the encryption keys set for the access point, refer to the access point manual.



POINT

Make sure that you specify the encryption keys. If you do not specify the keys, any computer with a wireless LAN card can be connected. This presents a risk that your data may be stolen or destroyed.

Item	Description
Encryption (WEP)	<p>Click the down arrow and select an encryption option.</p> <ul style="list-style-type: none"> ▪ <i>Disable</i>: Disables the encryption. In this case, "Create keys with Passphrase" and subsequent items are greyed out, and you cannot enter anything. ▪ <i>40 bit*</i>: The encryption is set. Select either "Create keys with Passphrase", "Create keys manually", or "ASCII Input", and enter the encryption keys. ▪ <i>104 bit*</i>: The encryption is set. Select either "Create keys with Passphrase", "Create keys manually", or "ASCII Input", and enter the encryption keys.
Create Keys with Passphrase	Not supported.
Passphrase	Not supported.
Create Keys Manually (Hexadecimal Input)	<p>Select this to use hexadecimal character codes to set the encryption keys (Keys 1 - 4).</p> <p>Enter a 10-digit value when you have selected [40 bit]* for the encryption. Enter a 26-digit value when you have selected [104 bit]* for encryption.</p> <p>Select if the network contains a card that is set with the encryption key using the character code. Specify the encryption keys with the same value used for other wireless LAN cards that are already set.</p>
ASCII Input	<p>Select to use the ASCII codes to set encryption keys (Keys 1 - 4). Select this if network does not contain other wireless LAN cards that are set with encryption key using character codes.</p> <p>Enter a 5-digit value when you have selected [40 bit]* for the encryption. Enter a 13-digit value when you have selected [104 bit]* for encryption.</p> <p>You can use the following characters: 0 - 9, A - Z, a - z, _ (underscore).</p> <p>For example, to set "ABC12" for the encryption key, enter "ABC12."</p>
Default Key	Click the down arrow, and select a key from Keys 1 - 4.

Table 2: Encryption Key Setup

7. When you finish your entry, click [Apply].
 8. Click [OK]. [PRISM Wireless Settings] closes.
- You have completed the parameter settings.

**POINT**

When using ADSL (PPPoE) with the infrastructure network to connect to the Internet, you must change the computer's MTU size set. To change MTU size, refer to the manual that comes with the access point.

* 40 bit and 104 bit encryption is the wireless LAN equivalent of 64 bit and 128 bit encryption, as set by Microsoft and wireless LAN manufacturers. This is the same encryption rate that is used by the Windows XP operating system, and was selected in order to align it closer to the wireless LAN standard. For consistency, the Windows 98 and 2000 utilities reflect the same modes.

Outside of wireless LAN environments, encryption is generally set at either 64 bit or 128 bit. However, the wireless LAN standard requires that 24 bits be reserved for fixed data. As a result, the user can only use 40 bits (64 minus 24) or 104 bits (128 minus 24) for encryption. This requirement also fixes the number of characters used for 128 bit encryption to 13 which is calculated as (13 x 8 bits = 104).

NETWORK CONNECTION: WINDOWS 98

The section describes how to set the network connection if your computer running Windows 98.

Network Settings

In this section, you set "TCP/IP Settings," and complete "Checking Computer Name and Workgroup" required for the network connection.

TCP/IP Settings

1. Click [Start]-> [Settings]->[Control Panel].
2. Double-click the [Network] icon. [Network] appears.
3. Perform the following steps.
 - Click [TCP/IP].
 - Click [Properties].

**POINT**

If you have more than one [TCP/IP..] entry, select [TCP/IP -> Intersil PRISM Wireless LAN PCI Card]. [TCP/IP Properties] appears.

4. Set an IP address. (When you are done, ask your network administrator to check the setting).

- AdHoc Network: Select [IP address], and enter a value for [IP address] and [Subnet Mask]. Refer to "About IP Addresses" on page 120 to set an IP address and subnet mask.
 - Infrastructure Network: Select [Obtain an IP address automatically].
5. Click [OK]. [Network] appears again.

In the next step, you will check the computer name and workgroup.

Checking the Computer Name and Workgroup

1. Click the [Identification] tab on the [Network] window.



POINT

If this tab is not found on the [Network] window, click [Start] -> [Settings] -> [Control Panel], and double-click the [Network] icon.

2. Check the entry for [Computer name] and [Workgroup]. Ask your network administrator and check the setting, if you have a network administrator.

Item	Description
Computer Name	A name to identify the computer on the network. You can specify any name for any computer. Use up to 15 single-byte characters. For easiest identification, use the model name or user name.
Workgroup	The name of the network group. Use up to 15 single-byte characters. <ul style="list-style-type: none"> ▪ <i>AdHoc Network</i>: Specify the same name to all computers within the same network. ▪ <i>Infrastructure Network</i>: Specify a workgroup name to connect to.
Computer Description	Additional description for the computer. This is not necessary.

Table 3: Computer Name and Workgroup



POINT

Including a period or other special characters may prevent you from connecting to the network.

3. Click [OK]. When a message appears prompting you to restart the computer, click [Yes].

Sharing

In this section, you set sharing of the drive, folder, and printer.

You need to set this only when you are sharing files or a printer with other computers on the network. When you share a drive, folder, or printer, you can use these from any computer on the network.

Setting File and Printer Sharing for Networks

1. Click [Start] -> [Settings] -> [Control Panel].
2. Double-click the [Network] icon. The [Network] window appears.
3. Click [File and Print Sharing...]. [File and Print Sharing] appears.
4. Click and check one or both of the options.
5. Click [OK]. [File and Printer Sharing for Microsoft Networks] is added under [The following network components are installed] on [Configuration] tab.
6. Click [OK]. [Network Properties] closes. Follow the instructions on the screen.
7. When a message appears prompting you to restart the computer, click [Yes].

Sharing Files

The following example shows how to set sharing the "Work" folder on the c drive.

1. Double-click [My Computer] -> [C: drive] on the desktop.
2. Right-click the "Work" folder, then click [Sharing] from the menu that appears. The [Work Properties] window appears.
3. Click [Sharing], and select items, as specified below.

Item	Description
Share Name	Specify a share name for the drive or folder that you want to share.
Access Type	Limits the read/write permission for the drive to be shared. <ul style="list-style-type: none"> ▪ Read-Only Password: Specifies read-only for the drive to be shared. ▪ Full Access Password: Allows read and write for the drive to be shared. ▪ Depends On Password: Identifies either Read-Only or Full, depending upon the password.
Passwords	A password used for [Access Type]. <ul style="list-style-type: none"> ▪ Read-Only Password: Specify a password to allow read. ▪ Full Access Password: Specify a password to allow read and write.

Table 4: Password Setup

4. Click [OK]. The folder is set for sharing, and the "Work" folder icon changes.

Printer Sharing

1. Click [Start] -> [Settings] -> [Printers]. [Printers] appears, showing the printers that are connected.
2. Right click the printer that you want to share, and then click [Sharing] from the menu that appears.
3. Click [Sharing], and select necessary items.

Item	Description
Not Shared	Disables printer sharing.
Shared as	Enables printer sharing
Share Name	Specifies a share name for the printer to be shared.
Comment	Enter a description of the printer to be shared.
Passwords	Specify passwords. If you specify a password, you need to enter it when using the printer.

Table 5: Printer Sharing

4. Click [OK]. The printer is set for sharing, and the printer icon changes.

Checking the Connection

After the network setting is completed, access the shared drive on another computer to check the connectivity of the wireless LAN network.

Accessing Another Computer

1. Double-click the [Network Neighborhood] on the desktop. The computers that are connected to the network are displayed.
2. Double-click the computer that you want to access. The drive that you set with "Sharing" is displayed. The drive is not displayed unless it is set for sharing, even if it exists.
3. Double-click the drive that you want to access. The drive is displayed showing its contents and made available to you.

If you have a question or problem, refer to "Troubleshooting" on page 115.

Checking the Connectivity

1. Click [Start] -> [Settings] -> [Control Panel].
2. Double-click the [PRISM Settings] icon. [PRISM Wireless Settings] appears.
3. Check the connectivity on the [Link] tab. The current condition of connection is displayed.

Item	Description
State	Shows the current condition of connection. The MAC address of the other computer that you are connected to is displayed, when the connection is successfully made. If you are connected to more than one computer, the computer that has the best connectivity is displayed.
Current Channel	Shows the current channel used for the connection.
Current Tx Rate	Shows the current transfer rate in Mbits/sec.
[Radio Off]/ [Radio On]	Click [Radio Off] to disconnect. Click [Radio On] to connect to network.
Rescan	Click to search for others to connect to.
Throughput (Bytes/sec)	Shows the actual transfer rate of the transfer data for send (Tx) and receive (Rx).
Link Quality	Shows [Excellent], [Good], [Fair], [Poor], or [Not Connected], depending on the link quality. This is not shown for the AdHoc connection.
Signal Strength	Shows [Excellent], [Good], [Fair], [Poor], or [Not Connected], depending on the signal strength. This is not shown for the AdHoc connection.

Table 6: Connectivity Condition

NETWORK CONNECTION: WINDOWS 2000

The section describes how to set the network connection for a computer with Windows 2000.

Network Settings

In this section, you set "TCP/IP Settings," and complete "Checking Computer Name and Workgroup," required for the network connection.

TCP/IP Settings

1. Click [Start] -> [Settings] -> [Control Panel].

2. Double-click the [Network and Dial-up Connections] icon. The [Network and Dial-up Connections] window appears.
3. Right click the [Local Area Connection], then click [Properties] from the menu that appears. The [Local Area Connection Properties] window appears.

POINT

More than one network adapter is installed in your system if more than one [Local Area Connection] entry is displayed. In this case, select the [Local Area Connection] entry with [Intersil PRISM Wireless LAN PCI Card] displayed under [Device Name].

4. Perform the following steps.
 - Click [Internet Protocol (TCP/IP)].
 - Click [Properties]. The [Internet Protocol (TCP/IP) Properties] window appears.
5. Set an IP address as indicated in Table 7. Ask your network administrator to check the setting.

Item	Description
For AdHoc Network	Set the IP address and subnet mask: Click [Use the following IP address], and enter a value for [IP address] and [Subnet mask]. Refer to "Setting IP Addresses" on page 120 to set an IP address and subnet mask.
For Infrastructure Network	Select [Obtain an IP address automatically]: For the DNS server, select [Obtain DNS server address automatically]. For the IP address, DNS server, and default gateway, follow the network administrator's instructions, if any.

Table 7: Setting an IP Address

6. Click [OK]. The [Local Area Connection Properties] window appears again.
7. Click [OK]. When a message appears prompting you to restart the computer, click [Yes].

Checking the full computer name and workgroup

1. Click [Start] -> [Settings] -> [Control Panel].
2. Double-click the [System] icon. [System Properties] appears.
3. Click the [Network Identification] tab.
4. Check [Full computer name] and [Workgroup]. Ask your network administrator and check the setting.

Item	Description
Full Computer Name	A name to identify the computer on the network. You can specify any name to each computer. For easier identification, use the model name or user name.
Workgroup	A name for the network group: <ul style="list-style-type: none"> ▪ <i>AdHoc Network:</i> Specify the same name to all computers within the same network. ▪ <i>Infrastructure Network:</i> Specify a workgroup name to connect to. To change the setting, click [Properties], and follow the instructions on the screen. [System Properties] appears again.

Table 8: Checking computer name and workgroup

5. Click [OK]. When a message appears prompting you to restart the computer, click [Yes].

Sharing

In this section, you set sharing of the drive, folder, and printer.

You only need to set this when you are sharing files or a printer with other computers on the network.

When you share a drive, folder, or printer, you can use them from any computer on the network.

Setting [File and Printer Sharing for Microsoft Networks]

1. Click [Start] -> [Settings] -> [Control Panel].
2. Double-click the [Network and Dial-up Connections] icon. The [Network and Dial-up Connections] windows appears.
3. Right click the [Local Area Connection], then click [Properties] from the menu that appears. [Local Area Connection Properties] appears.

POINT

More than one network adapter is installed in your system if more than one [Local Area Connection] entry is displayed. In this case, select the [Local Area Connection] entry with [Intersil PRISM Wireless LAN PCI Card] displayed under [Device Name].

4. If [File and Printer Sharing for Microsoft Networks] is displayed in the list, make sure that it is checked. If it is not checked, check it and click [OK]. You do not have to perform the following steps. Go to the next section, entitled “Sharing Files.”
If [File and Printer Sharing for Microsoft Networks] is **not** found in the list, click [Install], and perform Step 5 and subsequent steps. When you click [Install], the [Select Network Component Type] window appears.
5. Perform the following steps.
 - Click [Service].
 - Click [Add]. The [Select Network Service] window appears.
6. Perform the following steps.
 - Click [File and Printer Sharing for Microsoft Networks].
 - Click [OK]. You will go back to [Local Area Connection Properties], and [File and Printer Sharing for Microsoft Networks] is added to the list.
7. Click [OK].

 **POINT**
If you have changed the setting, [Close] is shown instead. Click [Close].

Sharing Files

The following example shows how to set sharing the “Work” folder on the c: drive.

1. On the desktop, double-click [My Computer]-> C: drive.
2. Right-click the “Work” folder, then click [Sharing] from the menu. The [Work Properties] window appears.
3. Click [Share this folder] and set necessary items, as indicated in the following table.

Item	Description
Share name	You can specify a share name for the drive or folder that you want to share.
Comment	You can enter the description for the drive or folder that you want to share.
User limit	Specifies the limit for the number of sharing users.
Permissions	Specifies the folder access privileges.
Caching	Specifies the caching for the folder.

Table 9: Sharing files

4. Click [OK]. The folder is set shared, and the “Work” folder icon changes.

Printer Sharing

1. Click [Start] -> [Settings] -> [Printers]. The Printers window appears, showing the printers that are connected.
2. Right click the printer that you want to share, then click [Sharing] from the menu that appears.
3. Click [Sharing], and select necessary items.

Item	Description
Not Shared	Disables printer sharing.
Shared As	Enables printer sharing.
Share Name	Specifies a share name of the printer to be shared.
Comment	Enter the description of the printer to be shared.
Passwords	If you specify a password, you need to enter it when using the printer.

Table 10: Printer Sharing

4. Click [OK]. The printer sharing is set, and the icon changes.

Checking the Connection

After the network setting is completed, access the shared drive on another computer to check the connectivity of the wireless LAN network.

Accessing Another Computer

1. Double-click the [My Network Places] icon on the desktop. [My Network Places] appears.
2. Double-click [Computers near me]. The computers that are connected to the network are displayed.
3. Double-click the computer that you want to access. The drive that you set with “Sharing” are displayed.
4. Double-click the drive that you want to access. The drive is displayed showing its contents and made available to you. If you have any questions or problems, refer to “Troubleshooting Table” on page 115.

Checking the Connectivity

1. Click [Start] -> [Settings] -> [Control Panel].
2. Double-click the [PRISM Settings] icon. [PRISM Wireless Settings] appears.
3. Check the connectivity on the [Link] tab. The current condition of connection is displayed.

Item	Description
State	Shows the current condition of connection. The MAC address of the other computer to which you are connected is displayed when the connection is successful. If you are connected to more than one computer, the computer that has the best connectivity is displayed.
Current Channel	Shows the current channel used for the connection.
Current Tx Rate	Shows the current transfer rate in Mbits/sec.
[Radio Off]/ [Radio On]	Click [Radio Off] to disconnect. Click [Radio On] to connect to the network.
[Rescan] button	Click this button to search for others to connect to.
Throughput (Bytes/sec)	Shows the actual transfer rate of the data transfer for send (Tx) and receive (Rx).
Link Quality	Shows either [Excellent], [Good], [Fair], [Poor], or [Not Connected], depending on the link quality. Not shown for AdHoc connection.
Signal Strength	Shows either [Excellent], [Good], [Fair], [Poor], or [Not Connected], depending on the signal strength. Not shown for AdHoc connection.

Table 11: Checking connectivity

CONNECTING WINDOWS XP SYSTEMS

This chapter describes how to set up the wireless LAN connection for computers that are running Windows XP.



POINT

When you receive your LifeBook, the integrated wireless LAN device and drivers have already been installed. This procedure outlines the steps for setting the device parameters.

Updated drivers and/or utilities may become available after this manual is printed; see any addenda or fliers that may be included in the system packaging.

Workflow

The proper setup of the wireless LAN connection requires that several steps be performed in the proper order. Following is a general outline of the steps to be performed. Each step is detailed later in this procedure.

1. Setting parameters
 - Setting the profile
 - Setting the encryption
2. Network settings
 - Setting the protocol and checking the network
 - Setting file and printer sharing
 - Checking the connection

Setting Parameters

1. Click [Start] -> [Control Panel].
2. Click [Network and Internet connection].
3. Click [Network connection]. A list of networks that are currently installed is displayed.
4. Right click [Intersil PRISM Wireless LAN PCI Card] in the list, and click [Properties] from the menu that is displayed. [Wireless Network Connection 2 Properties] appears.
5. Click the [Wireless Networks] tab. The [Wireless Networks] tab appears.
6. Perform the following steps.
 - Make sure that [Use Windows to configure my wireless network settings] is checked.
 - Click [Add] under [Preferred networks]. [Wireless Network Properties] appears.
7. Set parameters.
 - For the AdHoc network, specify the same value to all the computers, for which the encryption key is used for connection.
 - For the infrastructure network, specify the encryption key (network key) with the same value to the encryption key of the access point. For how to check

the encryption keys set for the access point, refer to the manual supplied with the access point.

POINT

Be sure to specify the encryption keys. If you do not specify the keys, any computer with a wireless LAN card can be connected. This presents a risk that other users may steal or destroy your data.

Item	Description	
Network Name SSID	Enter the network name to which you want to connect. This is a required item. For the network name, ask your LAN administrator. <i>AdHoc network:</i> Set the same name for all of the computers that are to be connected. <i>Infrastructure network:</i> Specify the same name as that specified on the access point that is to be connected. For access point instructions, refer to the manual that comes with the access point.	
Key Format	Click the down arrow and select the input for the Network key.	
	ASCII characters	Select this when using ASCII characters for the Network Key. Characters that can be used follow: 0-9, A-Z, a-z, and _ (underscore) <i>Example:</i> To set the key to "ABC12", input "ABC12".
	Hexadecimal characters	Select this when using hexadecimal characters for the Network Key. Use this if there is a wireless LAN card in the network that has the Network Key set to a character code. In 'Network Key', input the same value as the other wireless LAN card.

Table 12: Setting parameters

8. When you finish your entry, click [OK]. [Wireless Network Connection 2 Properties] appears again.
9. Make sure the network name you specified for the SSID in Step 7 is added under [Preferred networks].

Network Connection

The section describes how to set the network connection for a computer running Windows XP.

Network Settings

In this section, you set "TCP/IP Settings," and complete "Checking Computer Name and Workgroup" required for the network connection.

TCP/IP Settings

1. On [Wireless Network Connection Properties], click [General].

POINT

If [Wireless Network Connection 2 Properties] is not displayed, click [Start] -> [Settings] -> [Control Panel], and double-click the [Network Connection] icon.

Right click the [Wireless Network Connection], and then click [Properties] from the menu that appears.

2. Perform the following steps.
 - Click [Internet Protocol (TCP/IP)].
 - Click [Properties]. [Internet Protocol (TCP/IP) Properties] appears.
3. Set an IP address. Ask your network administrator and check the setting.

Item	Description
AdHoc Network	Set the IP address and subnet mask. Click [Use the following IP address]. Enter a value for [IP address] and [Subnet mask]. See "Setting IP Addresses" on page 120 to set IP address and subnet mask.
For Infrastructure Network	Select [Obtain an IP address automatically]. For the DNS server, select [Obtain DNS server address automatically]. For the IP address, DNS server, and default gateway, follow the network administrator's instructions, if any.

Table 13: Setting an IP address

5. Click [OK].

POINT

If you have changed the setting, [Close] is shown instead. Click [Close].

6. Close [Network Connection].

Checking the Full Computer Name and Workgroup

1. Click [Start] -> [Control Panel]. Make sure the Classic View is selected.
2. Double-click the [System] icon. [System Properties] appears.
3. Click the [Computer Name] tab.
4. Check [Full computer name] and [Workgroup]. Ask your network administrator and check the setting.

Item	Description
Computer Name	A name to identify the computer on the network. You can specify any name to each computer. Use up to 15 single-byte characters. For easier identification, use the model name or user name.
Workgroup	A name of the network group. Use up to 15 single-byte characters. <i>AdHoc Network:</i> Specify the same name to all computers within the same network. <i>Infrastructure Network:</i> Specify the workgroup name to connect to.

Table 14: Setting computer name and workgroup

To change the setting, click [Change], and follow the instructions on the screen. [System Properties] appears.

5. Click [OK]. When a message appears prompting you to restart the computer, click [Yes].

Sharing

In this section, you set sharing of the drive, folder, and printer.

You need to set this only when you are sharing files or a printer with other computers on the network.

When you share a drive, folder, or printer, you can use these from any computer on the network.

Setting [File and Printer Sharing for Microsoft Networks]

1. Click [Start] -> [Control Panel]. Make sure the Classic View is selected.
2. Double-click the [Network Connection] icon.
3. Right click the [Wireless Network Connection], and then click [Properties] from the menu that appears. [Wireless Network Connection Properties] appears.
4. If [File and Printer Sharing for Microsoft Networks] is displayed in the list:

Make sure that it is checked. If it is not checked, check it, and click [OK]. You do not have to perform the following steps. Go to “Sharing Files” section.

If [File and Printer Sharing for Microsoft Networks] is **not** found in the list, click [Install], and perform Step 5 and the subsequent steps. When you click [Install], [Select Network Component Type] appears.

5. Perform the following steps.
 - Click [Service].
 - Click [Add]. [Select Network Service] appears.
6. Perform the following steps.
 - Click [File and Printer Sharing for Microsoft Networks].
 - Click [OK]. You will go back to [Wireless Network Connection 2 Properties], and [File and Printer Sharing for Microsoft Networks] is added to the list.
7. Click [Close].

Sharing Files

The following example shows how to set sharing the “Work” folder on the c: drive.

1. Click [Start] -> [My Computer].
2. Double-click the [Local Disk (c:)] icon.
3. Right click the “Work” folder, and then click [Sharing and Security] from the menu that appears. [Work Properties] appears.
4. Click [If you understand the security risks but want to share files without running the wizard, click here].



POINT

If you have already clicked [If you understand the security risks but want to share files without running the wizard, click here], this window does not appear.

In the [Work Properties] window, the description under [Network Sharing and security] changes.

5. Check [Share this folder on the network]. Uncheck [Allow network users to change my files], if the shared folder is for read only.
6. Click [OK]. The folder is set shared, and the “Work” folder icon changes.

Printer Sharing

1. Press [Start]->[Control Panel] (or [Settings], if viewing in Classic mode)-> [Printers and Faxes]. The Printers and Faxes display will appear and the connected printers will be displayed.
2. Right-click the printer to be shared, and click [Sharing] from the menu that appears. The properties of the printer to be shared will be displayed. Set printer sharing.

On the display, the printer sharing setting is recommended by the Network Setup Wizard, but for the wireless LAN network, security is maintained by network name (SSID) or network key. The following steps allow you to set up printer sharing without using the Network Setup Wizard.

3. Click 'If you understand the security risks but want to share printers without running the wizard, click here. 'Enable Printer Sharing' will be displayed.
4. Select 'Just enable printer sharing'.
5. Click 'OK'. The printer properties will be indicated.
6. Select 'Share this printer'.
7. Enter the sharing printer name in 'Share name'.
8. Click OK. The printer will be shared, and the printer icon will become a sharing icon.

Checking the Connection

After the network setting is completed, access the shared drive on another computer to check the connectivity of the wireless LAN network.

Accessing Another Computer

1. Click [Start] -> [My Computer].
2. From the left menu in [Other Places], click [My Network Places].
3. From the left menu in [Network Tasks], click [View workgroup computers]. The workgroup in which you are participating will appear.
4. Double click the computer to which you want to connect. The drive that you set in [Computer Sharing] appears.
5. Double click the drive to which you want to connect. The contents of the drive will appear, and is available for use.

If you have a question or problem, refer to “Troubleshooting Table” on page 115.

Checking the Connectivity

1. Click [Start] -> [Control Panel].
2. Double-click the [PRISM Settings] icon. [PRISM Wireless Setting] appears.
3. Check the connectivity on the [Link] tab. The current condition of connection is displayed.

Item	Description
State	Shows the current condition of connection. The MAC address of the other computer that you are connected to is displayed, when the connection is successfully made. If you are connected to more than one computer, the computer that has the best connectivity is displayed.
Current Channel	Shows the current channel used for the connection.
Current Tx Rate	Shows the current transfer rate in Mbits/sec.
Radio Off/ Radio On	Click [Radio OFF] to disconnect. Click [Radio On] to connect to the network.
Rescan	Click this button to search for others to connect to.
Throughput (Bytes/sec)	Shows the actual transfer rate of the transfer data for send (Tx) and receive (Rx).
Link Quality	Shows the link quality. This is not shown for the AdHoc connection.
Signal Strength	Shows the signal strength. This is not shown for the AdHoc connection.

Table 15: Checking connectivity

TROUBLESHOOTING

This section contains troubleshooting information, including causes and actions, for problems you may find while using this device.

Troubleshooting Table

Problem	Possible Cause	Possible Solution
Exclamation mark (!) or cross (x) is attached to [Intersil PRISM Wireless LAN PCI Card].	Failure to recognize the device.	Restart the computer.
	Failure in installing the driver.	Restart the computer.
Other computers are not displayed when the [Network Computer] icon is double-clicked.	You didn't enter the password when Windows 98 started. You clicked [Cancel] or [ESC] when User Name/Password window was shown.	Make sure that you enter user name and password and click [OK] when starting Windows 98. If you forget your password, enter another user name. A new user name and password is registered in the computer.
	The network has not been set up correctly.	Check the setting for the protocol, workgroup, and sharing. To check this, you need a different procedure, depending upon the operating system that you use. Refer to the appropriate section of this chapter.
	It takes time before the network is searched and the computer connected is displayed.	Perform the following steps to search for the computer. <ul style="list-style-type: none"> ▪ Click [Start] -> [Search] -> [Other Computers]. ▪ Enter the computer name that you are connecting to in [Name], and click [Search]. ▪ Double-click icon of the computer that has been searched.
	Failure in installing the driver.	Make sure that the driver is correctly installed.
	The TCP/IP protocol is not installed, or, the IP address is not set correctly.	Make sure the TCP/IP protocol is installed. To check this, you need a different procedure, depending on the operating system that you use. Refer to the appropriate section of this manual.
Other computers are not displayed when the [Network Computer] icon is double-clicked.	The TCP/IP protocol is not installed, or, the IP address is not set correctly.	<p>If the TCP/IP protocol is installed, do the following to check the IP address:</p> <ol style="list-style-type: none"> 1. Windows 98: Click [Start] -> [Programs] -> [MS-DOS Prompt]. Windows 2000: Click [Start] -> [Programs] -> [Accessories] -> [Command Prompt]. Windows XP: Click [Start] -> [All Programs] -> [Accessories] -> [Command Prompt]. 2. Enter "IPCONFIG" command, and press [Enter]. (If your hard disk is C drive, enter C:\>ipconfig) <p>Check that the IP address is correctly displayed under the IP Address. Example: IP address: 10.0.1.3 Subnet Mask: 255.255.255.0 Default Gateway: 10.0.1.1</p>

LifeBook E Series – Appendix

Problem	Possible Cause	Possible Solution
<p>Other computers are not displayed when the [Network Computer] icon is double-clicked.</p> <p>(continued)</p>	<p>No communication due to poor radio signal.</p>	<p>Shorten the distance between computers or remove visible obstacles between them, and retry the connection.</p>
<p>IP packet isn't reaching its destination</p>	<p>Run the PING command to check the connection</p>	<p>Perform the following steps to run the PING command to check if the IP packet is correctly delivered to the destination.</p> <p>To run the PING command, the TCP/IP protocol must be installed. First you will determine your IP address, then you will make sure your IP address can respond, and then you will make sure other computers can be addressed.</p> <ol style="list-style-type: none"> 1. Windows 98: Click [Start] -> [Programs] -> [MS-DOS Prompt]. Windows 2000: Click [Start] -> [Programs] -> [Accessories] -> [Command Prompt]. Windows XP: Click [Start] -> [All Programs] -> [Accessories] -> [Command Prompt]. 2. Type: <code>ipconfig > directory\filename</code> where <i>directory</i> and <i>filename</i> represent the location at which you want to find the IP address. 3. Click [Enter], then go to the location you specified above. The IP address for your system will be contained in the file. 4. To check that your IP address is functioning properly, go back to the DOS prompt and type: <code>ping <IP address></code>, then press [Enter]. You will receive several replies, followed by the PING statistics (similar to below). 5. To check that your system is communicating with other systems, go to the DOS prompt and type: <code>\>ping XXX.XXX.XXX.XXX</code>. (With the destination IP address in place of XXX.XXX.XXX.XXX). <p>Example: if the destination IP address is 10.0.1.3:</p> <pre>C:\>ping 10.0.1.3</pre> <p>A message similar to the following appears if the connection is successful.</p> <p>Pinging 10.0.1.3 with 32 bytes of data:</p> <pre>Reply from 10.0.1.3: bytes=32 time=1ms TTL=32 Reply from 10.0.1.3: bytes=32 time<10ms TTL=32 Reply from 10.0.1.3: bytes=32 time=4ms TTL=32 Reply from 10.0.1.3: bytes=32 time<10ms TTL=32</pre> <p>If the connection fails, [Request timed out], [Destination host unreachable], or a similar message appears. In this case, refer to the "Other computers are not displayed" portion of this chapter.</p>

Wireless LAN User's Guide

Problem	Possible Cause	Possible Solution
Cannot connect to the network	There are several possible causes, as listed to the right. Refer to the specific section of this manual or your user's manual.	<p>The following causes are possible. Check each one of them.</p> <ul style="list-style-type: none"> ▪ The network name or encryption key is not right. ▪ The driver has not correctly started. ▪ The destination computer is not turned on. ▪ You do not have the access privilege to the destination computer. ▪ The card has failed. ▪ Hardware conflict.
I want to remove the driver. (Windows 98)		<p>Windows 98: When removing the driver, make sure that the device is attached to the computer. If you try to remove the driver while the device is detached from the computer, the driver is not removed.</p> <ol style="list-style-type: none"> 1. Right click the [My Computer] icon on the desktop, and then click [Properties] from the menu that appears. [System Properties] appears. 2. Click the [Device Manager] tab. 3. Click [+] beside [Network adapters]. 4. Perform the following steps. <ul style="list-style-type: none"> ▪ Click [Intersil PRISM Wireless LAN PCI Card]. ▪ Click [Remove]. [Confirm Device Removal] appears. 5. Click [OK]. The device is removed, and [System Settings Change] appears. 6. Click [No]. 7. Close [System Properties]. 8. Make sure that the icon has disappeared from the task tray in the lower right corner of the screen. 9. Click [Start] -> [Settings] -> [Control Panel]. [Control Panel] appears. 10. Double-click [Add/Remove Programs]. [Add/Remove Programs Properties] appears. 11. Double-click [PRISM 11Mbps Wireless LAN for Windows]. A window appears asking you if you really want to remove the driver. 12. Click [Yes]. When the driver is removed, a window appears showing that the driver has been removed. 13. Click [OK]. 14. Close [Add/Remove Programs Properties] and [Control Panel]. 15. Shut down Windows, and turn off the computer.

LifeBook E Series – Appendix

Problem	Possible Cause	Possible Solution
I want to remove the driver (Windows 2000)		<p>Windows 2000: When removing the driver, make sure that the device is attached to the computer. If you try to remove the driver while the device is detached from the computer, the driver is not removed.</p> <ol style="list-style-type: none"> 1. Right click the [My Computer] icon on the desktop, and then click [Properties] from the menu that appears. [System Properties] appears. 2. Click the [Hardware] tab. 3. Click [Device Manager...]. The [Device Manager] window appears. 4. Click [+] beside [Network adapters]. 5. Right click [Intersil PRISM Wireless LAN PCI Card], and click [Uninstall] from the menu that is displayed. [Confirm Device Removal] appears. 6. Click [OK]. 7. Close [System Properties]. 8. Make sure that the icon has disappeared from the task tray in the lower right corner of the screen. 9. Click [Start] -> [Settings] -> [Control Panel]. 10. Double-click [Add/Remove Programs]. [Add/Remove Programs] appears. 11. Perform the following steps. <ul style="list-style-type: none"> ▪ Click [PRISM 11Mbps Wireless LAN for Windows]. ▪ Click [Change/Remove]. <p>A window appears asking you if you really want to remove the driver.</p> <ol style="list-style-type: none"> 12. Click [Yes]. <p>When the driver is removed, a window appears showing that the driver has been removed.</p> <ol style="list-style-type: none"> 13. Click [OK]. 14. Close [Add/Remove Programs] and [Control Panel]. 15. Shut down Windows, and turn off the computer.

Problem	Possible Cause	Possible Solution
I want to remove the driver (Windows XP)		<p>Windows XP: When removing the driver, make sure that the device is attached to the computer. If you try to remove the driver while the device is detached from the computer, the driver is not removed.</p> <ol style="list-style-type: none"> 1. Click [Start], right click [My Computer], and then click [Properties] from the menu that appears. [System Properties] appears. 2. Click the [Hardware] tab. 3. Click [Device Manager]. 4. Click [+] beside [Network adapters]. 5. Right click [Intersil PRISM Wireless LAN PCI Card], and click [Uninstall] from the menu that is displayed. [Confirm Device Removal] appears. 6. Click [OK]. 7. Close [System Properties]. 8. Make sure that the icon has disappeared from the task tray in the lower right corner of the screen. 9. Click [Start] -> [Control Panel]. [Control Panel] appears. 10. Double-click [Add/Remove Programs]. [Add/Remove Programs] appears. 11. Perform the following steps. <ul style="list-style-type: none"> ▪ Click [PRISM 11Mbps Wireless LAN for Windows]. ▪ Click [Change/Remove]. <p>A window appears asking you if you really want to remove the driver.</p> <ol style="list-style-type: none"> 12. Click [Yes]. <p>When the driver is removed, a window appears showing that the driver has been removed.</p> <ol style="list-style-type: none"> 13. Click [OK]. 14. Close [Add/Remove Programs] and [Control Panel]. 15. Shut down Windows, and turn off the computer.

IF A SECOND LAN DEVICE IS INSTALLED

Instructions for disabling another LAN device

If you have another LAN card on your computer running Windows 98, perform the following steps to disable that LAN card before installing the driver.

For Windows 98

1. Click [Start] -> [Settings] -> [Control Panel].
2. Double-click [System]. [System Properties] appears.
3. Click [+] beside [Network adapters], and double-click the standard built-in LAN device.

The following devices appear depending on your computer model.

- [Intel(R) 82559 Fast Ethernet LOM with Alert on LAN 2*]
- [Intel(R) 8255x-based PCI Ethernet Adapter(10/100)]
- [Realtek RTL8139(A/B/C/8130)PCI Fast Ethernet NIC]
- or others.

The LAN Card Properties window appears.

4. Check [Set disable with this hardware profile], and click [OK]. An [x] mark is added to the LAN card icon.
5. Click [OK].
6. Restart the system.

If the IP address is already assigned to the computer in the network, ask the network administrator to check the IP address to be set for the computer.

If no access point is found in the network:

An IP address is expressed with four values in the range between 1 and 255.

Set the each computer as follows: The value in parentheses is a subnet mask.

<Example>

Computer A: 192.168.100.2 (255.255.255.0)

Computer B: 192.168.100.3 (255.255.255.0)

Computer C: 192.168.100.4 (255.255.255.0)

:

:

Computer X: 192.168.100.254 (255.255.255.0)

ABOUT IP ADDRESSES

Setting IP Addresses

If you are not sure how to set the IP address, refer to the following procedure.

If you have an access point (DHCP server) on the network, set the IP address as follows:

Windows 98: [Obtain an IP address automatically]

Windows 2000: [Obtain an IP address automatically]

Windows XP: [Obtain an IP address automatically]



POINT

A DHCP server is a server that automatically assigns IP addresses to computers or other devices in the network. There is no DHCP server for the AdHoc network.

SPECIFICATIONS

Technical Specifications for Integrated Wireless LAN Device

Item	Description
Network Type	IEEE 802.11b
Transfer Rate	11/5.5/2/1Mbps (auto change)
Frequency Range	2,400 - 2,473 MHz
Channels	One of 11 channels is used
Card Type	Non-intelligent
VCC	Class B
Security	Network name, encryption key
Supported Operating Systems	Windows 98, Windows 2000, Windows XP
Power Current	Max: 350mA
Maximum number of units recommended for wireless LAN (AdHoc network)	10 or less

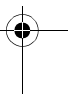
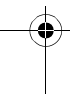

LifeBook E Series - Appendix

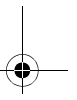
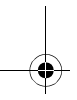
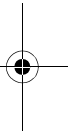
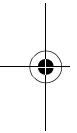

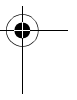
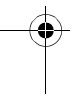

Index

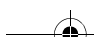
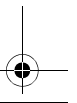
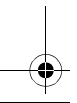
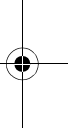
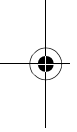

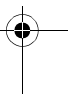
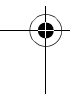
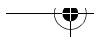

LifeBook E Series

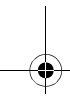
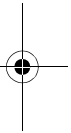
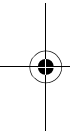

A

AC	
adapter	33, 84, 91
indicator	14
plug adapters	77
ACPI	39
Anti-theft Lock Slot	10
Audio	83
Auto Insert Notification	49
Auto/Airline Adapter	33, 91

B

Battery	66
bay	13
care	78
charging indicator	15
conserving power	38
dead	66
faulty	66
increasing life	78
level indicators	14
lithium ion battery	43, 93
low	43
recharging	43
replacing	44
shorted	44
suspend mode	43
BayManager	24, 87
BIOS	91
Guide	36
memory	83
setup utility	35
Boot	91
Boot Sequence	35
Built-in Speakers	62

C

Cache Memory	83, 91
CapsLock	16
CD-RW Drive	83
Clicking	21
Closed Cover Switch	8
Cold-swap	23
COMM Port	91

Communications	83
Communications Port	55
Configuration Label	13
Control	47
Cursor	21
Cursor Keys	17

D

DC Output Cable	33
DC Power Jack	33
DC power jack	12
Device Ports	55, 84
Disk	
access indicator	15
care	78
Display	34, 67, 68
Display Panel	8
adjusting	34
brightness	34
closing	34
latch	8
opening	34
Display Timeout	39
Docking Port	12, 57
Docking Station	63
Dolby Headphone	48
Double-Clicking	21
Dragging	22
Drivers and Application CD	72
DVD/CD-ROM	
care	79
drive	46
tray release	47
DVD/CD-RW drive	
Control Panel	47

E

Error Messages	70
Extended Memory	92
External Monitor Port	12, 57

F	
F7	18
F8	18
F9	18
Flexible	23
Flexible Bay	11
cold-swapping	23
devices	23
hot-swapping	24
installing	23
release button	11
removing	23
Floppy Disk	
ejecting	45
formatting	45
initializing	45
loading	45
preparing	45
write protect	45
Floppy Disk Drive	45, 63, 83
access indicator	15
care	78
Fujitsu Service Assistant	87
Function Key	
F10	18
F3	18
F4	18
F5	18
F6	18
F7	18
F8	18
F9	18
FN	18
H	
Hard Disk Drive	50, 63
access indicator	15
formatting	50
internal	50
Hard Disk Timeout	39
Headphone Jack	9, 56
Hibernation Feature	39
Hot-swap	24
I	
Infrared Port	12, 55
Integrated Pointing Device	83
IR Wireless Mouse Receiver	8
IrDA	55
K	
Keyboard	9, 17, 63
cursor keys	17
function keys	17
numeric keypad	17
windows keys	17
L	
LAN port	12, 55
LifeBook	
care	77
storing	77
traveling	77
LifeBook Security Application Panel	9, 83, 87
buttons	28
configuring	28
deactivating	29
launching applications	28
operating	27
passwords	26
uninstalling	27
LS-120	
drive	83
M	
Media drive	
access indicator	15
Media Player	
Control Panel	
loading	46
removing	47
Software	46
using	48
Memory	83
capacity	54
compartment	13, 53
extended	54
installing	53
removing	53
system	54
upgrade module	53
Memory Upgrade Module	64
Microphone Jack	9, 56

- Modem Jack 55
- Modem port 10
- Modem Result Codes 71
- Modular Devices 23
- installing 23
- removing 23
- Mouse
- See ErgoTrac and/or Touchpad
- N**
- Numeric Keypad 17
- NumLk 15
- P**
- Parallel Port 12, 55, 64, 93
- PC Card 51, 65
- access indicator 15
- care 79
- installing 51
- removing 51
- slot 10
- type II 51
- unlock 52
- PC Card Slots 10
- Pointing Device 9
- POST 94
- Power 84
- AC adapter 33
- Auto/Airline adapter 33
- button 8
- failure 65
- indicator 14
- management 38
- off 40
- on 35
- power 33
- Power and Suspend/Resume button 35, 38, 67
- Power Management 39
- Power On Self Test 35, 70
- Pre-Installed Software 86
- manuals 87
- tutorials 86
- PS/2 94
- PS/2 Port 12, 55
- R**
- Registration 36, 37
- Resolution 83
- Restarting 40
- RJ-11 55
- S**
- ScrLk 16
- Security 16
- Security Indicator 16
- Security indicator 16
- Serial Port 12, 55, 64, 94
- Setting 26
- Shut Down 40
- Software 46
- See Pre-installed Software
- Specifications 83
- Status Indicator Panel 8, 14
- Stereo Speakers 8
- Suspend 94
- Suspend Mode 38
- S-Video Out Port 12
- System Memory 83
- T**
- Theft Prevention Lock 84
- TouchPad 21
- Touchpad 21
- buttons 21
- controls 22
- Troubleshooting 61
- U**
- Universal Serial Bus Port 55
- USB 55, 64
- port 12
- V**
- Video 83
- Video RAM 83

W

Windows keys	17
Application key	17
Start keys	17
Windows Product Activation	36
Wireless Infrared Mouse Port	56
Wireless LAN	
before using	104
characteristics	104
Connecting Windows 98/2000 Systems	105
Connecting Windows XP Systems	111
Troubleshooting	115