



# Packaged Cooling with Electric Heat Rooftop Units

---

Precedent™  
TSC060-120  
50 Hz





## Introduction

---



**Precedent™ . . . The same Trane quality.. with added flexibility.** Precedent is a flexible line of packaged units that covers a wide variety of applications.

ReliaTel™ microprocessor controls provide superior flexibility for the simplest to the most sophisticated applications. In addition to controls, Precedent offers many other outstanding features and option choices.

With its sleek compact cabinet, rounded corners and beveled top, it may just be the most aesthetically pleasing packaged unit on the planet. And, of course, Precedent carries the Trane reputation for excellence, quality and reliability. *It's hard to stop a Trane.*

From simple applications, to the most complex, Precedent has the solution.

# Contents

---

<b>Introduction</b>	<b>2</b>
<b>Features and Benefits</b>	<b>4</b>
<b>Application Considerations</b>	<b>9</b>
<b>Selection Procedure</b>	<b>10</b>
<b>Model Number Description</b>	<b>12</b>
<b>General Data</b>	<b>13</b>
<b>Performance Data</b>	<b>14</b>
<b>Zone Controls</b>	<b>33</b>
<b>Electrical Data</b>	<b>34</b>
<b>Jobsite Connections</b>	<b>35</b>
<b>Dimensional Data</b>	<b>36</b>
<b>Weights</b>	<b>44</b>
<b>Mechanical Specifications</b>	<b>45</b>

# Features and Benefits



### Unit Cabinet

The compact cabinet with rounded corners takes up less room and is less costly to ship. The beveled and ribbed top is not only aesthetically pleasing, it is designed to prevent water from pooling.

### Single Point Power

A single electrical connection powers the unit.



### Compressors

Precedent™ contains the best compressor technology available to achieve the highest possible performance. Our compressor line includes Trane built reciprocating and scrolls.

### Easy Access Panels

Easy access panels reduce the number of possible water entry points.

### Low Ambient Cooling

All Precedent units have cooling capabilities down to 0°F as standard.

### Easy Access Panels

Remove two screws for access to the standardized internal components and wiring.

### Easy-Adjust Idler Arm

With the Easy-Adjust Idler Arm, the belt and sheaves can be quickly adjusted without moving the mounted fan motor. The result is a major savings in time and money.

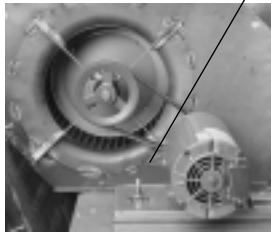

### Patented Condenser Coil

Precedent boasts a patented 1+1+1 Hybrid coil, permanently gapped for easy of cleaning.



### Colored And Numbered Wiring

You save time and money tracing wires and diagnosing the unit.

### Convertible Units

- The units ship in a downflow configuration. They can be easily converted to horizontal by simply moving two panels.
- Units come complete with horizontal duct flanges so the contractor doesn't have to field fabricate them. These duct flanges are a time and cost saver.



### Sloped Drain Pans

Every Precedent unit has a non-corrosive, removable, double-sloped drain pan that's easy to clean and reversible to allow installation of drain trap on either side of the unit.

### Through the Base Condensate

Every unit includes provisions for through the base condensate drain connections. This allows the drain to be connected through the roof curb instead of a roof penetration.

### Foil-Faced Insulation

All panels in the Evaporator section of the unit have cleanable foil-faced insulation. All edges are either captured or sealed to ensure no fibers get into the airstream.

### Unit Base

For added water integrity, Precedent has a raised 29 mm (1 1/8") lip around the unit's downflow supply and return to prevent water from blowing into the ductwork.

# Features and Benefits

---

## Standardized Components

- Components are placed in the same location on all Precedent™ units. Familiarize yourself with one Precedent and you are familiar with every Precedent.

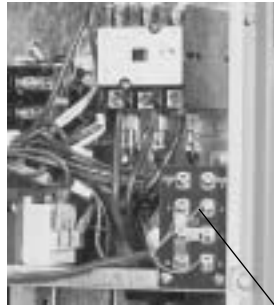

## Easy Access Low Voltage Terminal Board

Precedent's Low Voltage Terminal Board is external to the electrical control cabinet. It is extremely easy to locate and attach the thermostat wire. This is another cost and time saving installation feature.

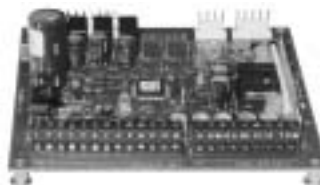

## Low Voltage Connections

The wiring of the low voltage connections to the unit and the zone sensors is as simple as 1-1, 2-2, and 3-3. This simplified system makes it easy for the installer to wire

## Single-Side Service

Single-side service is standard on all Precedent units.

## Flexible Applications

- Only two roof curbs for the 5-10 ton Precedent line. . .simplifies curb selection.
- ReliaTel microprocessor controls to meet either the simple or the more complex application.
- Airflow is outstanding. The Precedent can replace an older machine with old ductwork and, in many cases, improve comfort through better air distribution.
- Belt drive — standard or oversized supply fan motors meet a wide airflow range.
- Precedent offers ultimate flexibility. Options and components are not pre-packaged at the factory. Units are built to order in our standard "shortest in the industry" ship cycle time.

# Features and Benefits

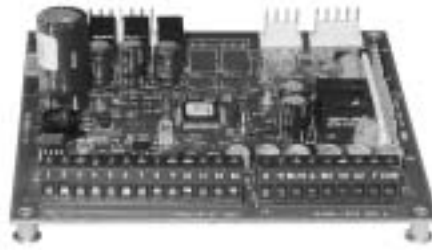

## Micro Controls

Several years ago, Trane was the first to introduce microprocessor controls into the Light Commercial Market. That design, along with immeasurable experience, has provided the technology for Trane's second-generation ReliaTel™ microprocessor controls.

### ReliaTel™ Micro:

- Provides unit control for heating, cooling, and ventilating by utilizing input from sensors that measure outdoor and indoor temperature.
- Improves quality and reliability through the use of time-tested microprocessor controls and logic.
- Prevents the unit from short cycling, considerably improving compressor life.
- Ensures that the compressor will run for a specific amount of time, which allows oil to return for better lubrication, enhancing the reliability of the compressor.
- Reduces the number of components required to operate the unit, thereby reducing possibilities for component failure.

- Eliminates the need for field-installed components with its built-in anti-short-cycle timer, time delay relay and minimum "on" time controls. These controls are factory tested to assure proper operation.
- Requires no special tools to run the Precedent unit through its paces during testing. Simply place a jumper between Test 1 and Test 2 terminals on the Low Voltage Terminal Board and the unit will walk through its operational steps. The unit automatically returns control to the zone sensor after stepping through the test mode a single time, even if the jumper is left on the unit.
- As long as the unit has power and the LED is lit, the Micro is operational. The light indicates that the Micro is functioning properly.
- Features expanded diagnostic capabilities when used with Trane's Integrated Comfort™ Systems.
- As an energy benefit, softens electrical "spikes" by staging on fans, compressors and heaters.
- The Intelligent Fallback or Adaptive Control is a benefit to the building occupant. If a component goes astray, the unit will continue to operate at predetermined temperature set points.
- Intelligent Anticipation is a standard feature of the Micro. Functioning constantly, the Micro and zone sensors work together in harmony, to provide tight comfort control.

# Features and Benefits

---

## Factory-installed Options

### Hinged Access Doors

These doors permit easy access to the filter, fan/heat, and compressor/control sections. They reduce the potential roof damage from screws or sharp access door corners.

### Economizer

Equipped with either dry bulb, reference or comparative enthalpy sensing, this feature provides free cooling as the outdoor temperature and/or humidity decreases. Economizers, correctly installed, offer a valuable energy savings. Factory-installed economizers save time and ensure proper installation.

### Clogged Filter/Fan Fail Switches

These sensors allow a zone sensor service light or Integrated Comfort System to indicate a dirty filter or a fan that's not working. The field installation charges for these valuable feedback devices often eliminate them from consideration. Factory installation can make such features a good investment.

### Comm-3/4 Trane Communication Interface

Available factory or field-installed. This module when applied with ReliaTel™ easily interfaces with Trane's Integrated Comfort™ System.



The following options round-out the complete line of Precedent™ options:

- 0 - 50% Manual or Motorized Outside Air
- Hail Protection Quality Coil Guards
- Electric Heaters (available as field installed accessories)
- Discharge Air Sensor
- Wide array of Zone Sensors and Thermostats
- Factory built Roof Curb

### One of Our Finest Assets:

Trane Sales Representatives are a Support group that can assist you with:

- Product
- Application
- Service
- Training
- Special Applications
- Specifications
- Computer Programs and much more

Precedent has the features and benefits that make it first class in the light commercial rooftop market. Designed with input from field contractors and engineers, its airflow performance is outstanding.

**Precedent...The same Trane quality...with added flexibility.**

# Features and Benefits

## Quality And Reliability Testing

- All Precedent™ designs were rigorously rain tested at the factory to ensure water integrity.
  - Actual shipping tests were performed to determine packaging requirements. Units were test shipped around the country to determine the best packaging.
  - Factory shake and drop tests were used as part of the package design process to help assure that the unit arrives at the job site in top condition.
  - Rigging tests include lifting a unit into the air and letting it drop one foot, assuring that the lifting lugs and rails hold up under stress.
- We perform a 100% coil leak test at the factory. The evaporator and condenser coils are leak tested at 1375 kPa (200 psig) and pressure tested to 3100 kPa (450 psig).
  - All parts are inspected at the point of final assembly. Sub-standard parts are identified and rejected immediately.
  - Every unit receives a 100% unit run test before leaving the production line to make sure it lives up to rigorous Trane requirements.

**We test designs at our factory not on our customers!**

## VariTrac™

### VariTrac

When Trane's changeover VAV System for light commercial applications is coupled with Precedent, it provides the latest in technological advances for comfort management systems and can allow thermostat control in every zone served by VariTrac.

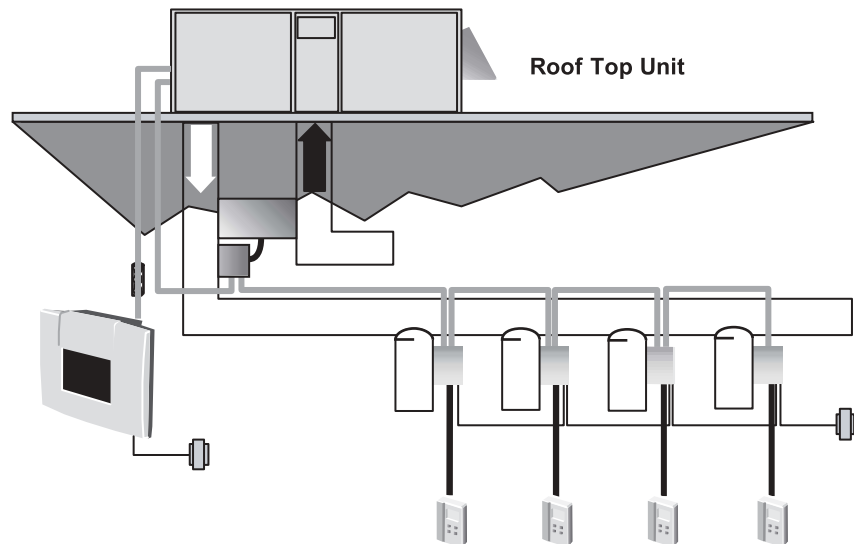



# Application Considerations

---

Application of this product should be within the cataloged airflow and cooling considerations.

## **Low Ambient Cooling**

The Precedent™ line features, with ReliaTel™ microprocessor controls, low ambient cooling down to 18°C (0°F). Contact your local Trane Representative for more assistance with low ambient cooling applications.

## **Barometric Relief**

This product line offers an optional barometric relief damper. for use in conjunction with economizer option. This accessory consists of gravity dampers which open with increased pressure. As the building air pressure increases, the pressure in the unit return air section also increases, opening the dampers and relieving the conditioned space.

NOTE: THE EFFECTIVENESS OF BAROMETRIC RELIEF DAMPER DURING ECONOMIZING OPERATION IS SYSTEM RELATED.

PRESSURE DROP OF THE RETURN AIR SYSTEM SHOULD BE CONSIDERED TO CONTROL BUILDING PRESSURIZATION.

## **Condensate Trap**

The evaporator is a draw-thru configuration. A trap must be field provided prior to start-up on the cooling cycle.

## **Clearance Requirements**

The recommended clearances identified with unit dimensions should be maintained to assure adequate service maximum capacity and peak operating efficiency. Actual clearances which appear inadequate should be reviewed with the local Trane sales personnel.

## **Unit Pitch**

These units have reversible sloped condensate drain pans. Units must be installed level, any unit slope must be toward the side of unit where condensate drain is connected.



# Selection Procedure - SI Units

## Cooling Capacity

### Step 1

Calculate the building's total and sensible cooling loads at design conditions. Use the Trane calculation methods or any other standard accepted method.

Factors used in unit selection:

#### A

Total Cooling Load: 16.7 kW

#### B

Sensible Cooling Load: 11.7 kW

#### C

Airflow: 3400 m<sup>3</sup>/h

#### D

Electrical Characteristics: 380-415/50/3

#### E

Summer Design Conditions: Entering Evaporator Coil: 27 DB, 19 WB Outdoor Ambient: 35

#### F

External Static Pressure: 110 Pa

### Step 2

Table PD-1 shows that a TSC060AD has a gross cooling capacity of 17.8 kW and 14.4 kW sensible capacity at 3400 m<sup>3</sup>/h and 35 DB outdoor ambient with 27 DB, 19 WB air entering the evaporator.

#### To Find Capacity at Intermediate Conditions Not in the Table

When the design conditions are between two numbers that are in the capacity table, interpolation is required to approximate the capacity. Note: Extrapolation outside of the table conditions is not recommended.

### Step 3

In order to select the correct unit which meets the building's requirements, the fan motor heat must be deducted from the gross cooling capacity. The amount of heat that the fan motor generates is dependent on the effort by the motor - cfm and static pressure. To determine the total unit static pressure:

External Static (duct system)	110 Pa
Standard Filter 1 in. from Table PD-21	37 Pa
Economizer (100% Return Air) Table PD-21	5 Pa
Electric Heater Size 7.5 kW from Table PD-21	17 Pa
Total Static Pressure	169 Pa

**Note:** The Evaporator Fan Performance Table PD-6 has deducted the pressure drop for a 25 mm filter already in the unit (see note below Table PD-6). Therefore, the actual total static pressure is 169-17 (from Table PD-21) = 152 Pa.

With 3400 m<sup>3</sup>/h and 152 Pa Table PD-6 shows .67 kW for this unit. Note below the table gives a formula to calculate Fan Motor Heat, Fan Motor Heat (kW) = 1.144 x (Fan kW) + 0.132 = 1.144 x 0.67 + 0.132 = 0.90 kW

Now subtract the fan motor heat from the gross cooling capacity of the unit:  
Net Total Cooling Capacity = 17.8 kW - 0.9 = 16.9 kW.

Net Sensible Cooling Capacity = 14.4 kW - 0.9 = 13.5 kW.

### Step 4

If the performance will not meet the required load of the building's total or sensible cooling load, try a selection at the next higher size unit.

## Heating Capacity

### Step 1

Calculate the building heating load using the Trane calculation form or other standard accepted method.

### Step 2

Size the system heating capacity to match the calculated building heating load. The following are building heating requirements:

#### A

Total heating load of 5 kW

#### B

2000 cfm

#### C

380 volt/3 phase Power Supply

The electric heat accessory capacities are listed in Table PD-23. From the table, the smallest heater will deliver 7.5 kW at 380 V. Referring to Table ED-2, the electric heater selection is BAYHTRR412A.

#### Air Delivery Selection

External static pressure drop through the air distribution system has been calculated to be 110 Pa. From Table PD-21 static pressure drop through the economizer is 5 Pa and the 7.5 kW heater is 17 Pa (110 + 5 + 17). Enter Table PD-6 for a TSC060AD at 3400 m<sup>3</sup>/h and 132 Pa static pressure. The standard motor will give the desired airflow at a rated kW of 0.64.

#### Accessory Selection

Select accessories needed to accommodate the application.

# Selection Procedure - IP Units

## Cooling Capacity

### Step 1

Calculate the building's total and sensible cooling loads at design conditions. Use the Trane calculation methods or any other standard accepted method.

Factors used in unit selection:

#### A

Total Cooling Load: 59 MBh

#### B

Sensible Cooling Load: 40 MBh

#### C

Airflow: 2000 cfm

#### D

Electrical Characteristics: 380-415/50/3

#### E

Summer Design Conditions: Entering Evaporator Coil: 80 DB, 67 WB Outdoor Ambient: 95

#### F

External Static Pressure: 0.45 in. wg

### Step 2

Table PD-1a shows that a TSC060AD has a gross cooling capacity of 62.0 MBh and 46.4 MBh sensible capacity at 2000 cfm and 95 DB outdoor ambient with 80 DB, 67 WB air entering the evaporator.

### To Find Capacity at Intermediate Conditions Not in the Table

When the design conditions are between two numbers that are in the capacity table, interpolation is required to approximate the capacity. Note: Extrapolation outside of the table conditions is not recommended.

### Step 3

In order to select the correct unit which meets the building's requirements, the fan motor heat must be deducted from the gross cooling capacity. The amount of heat that the fan motor generates is dependent on the effort by the motor - cfm and static pressure. To determine the total unit static pressure:

External Static (duct system)	0.45 wg
Standard Filter 1 in. from Table PD-21a	0.15 wg
Economizer (100% Return Air) Table PD-21a	0.02 wg from
Electric Heater Size 26 MBh from Table PD-21a	0.07 wg
Total Static Pressure	0.69 wg

**Note:** The Evaporator Fan Performance Table PD-6a has deducted the pressure drop for a 1 in. filter already in the unit (see note below Table PD-6a). Therefore, the actual total static pressure is 0.69 - 0.15 (from Table PD-21a) = 0.50 wg.

With 2000 cfm and 0.50 wg, Table PD-6a shows .83 bhp for this unit. Note below the table gives a formula to calculate Fan Motor Heat, Fan Motor Heat (MBh) =  $2.915 \times (\text{Fan BHP}) + 0.451$  =  $2.915 \times 0.83 + 0.451 = 2.87$  MBh

Now subtract the fan motor heat from the gross cooling capacity of the unit:  
 Net Total Cooling Capacity = 62 MBh - 2.87 = 59.1 MBh.

Net Sensible Cooling Capacity = 46.4 MBh - 2.87 = 43.5 MBh.

### Step 5

If the performance will not meet the required load of the building's total or sensible cooling load, try a selection at the next higher size unit.

## Heating Capacity

### Step 1

Calculate the building heating load using the Trane calculation form or other standard accepted method.

### Step 2

Size the system heating capacity to match the calculated building heating load. The following are building heating requirements:

#### A

Total heating load of 15 MBH

#### B

2000 cfm

#### C

380 volt/3 phase Power Supply

The electric heat accessory capacities are listed in Table PD-23a. From the table, the smallest heater will deliver 26 MBh at 380 volts. Referring to Table ED-2, the electric heater accessory selection is BAYHTRR412A.

### Air Delivery Selection

External static pressure drop through the air distribution system has been calculated to be 0.45 inches of water. From Table PD-21a static pressure drop through the economizer is 0.02 and the 26 kW heater is 0.07 inches of water (0.45 + 0.02 + 0.07). Enter Table PD-6a for a TSC060AD at 2000 cfm and 0.54 static pressure. The standard motor will give the desired airflow at a rated bhp of about 1.01.

### Accessory Selection

Select accessories needed to accommodate the application.



# Model Number Description

**T S C 060 A D R O A \*\* C 0 0 0 0 0 0 0 0 0 0 0 1**  
**1 2 3 4,5,6 7 8 9 10 11 12,13 14 15 16 17 18 19 20 21 22 23 24 25**

**Digit 1 - Unit Function**

T = DX Cooling

**Digit 2 - Efficiency**

S = Standard Efficiency

**Digit 3 - Airflow**

C = Convertible

**Digits 4,5,6 - Nominal Gross Cooling Capacity (MBh)**

	kW	Tons
060	17.6	5
072	21.1	6
090	26.4	7.5
102	29.9	8.5
120	35.1	10

**Digit 7 - Major Design Sequence**

A = First

**Digit 8 - Unit Voltage**

D = 380-415/50/3

**Digit 9 - Unit Controls**

R = ReliaTel™ Microprocessor

**Digit 10 - Heating Capacity**

0 = No Electric Heat

**Digit 11 - Minor Design Sequence**

A = First Sequence

**Digits 12, 13 - Service Sequence**

\*\* = Factory Assigned

**Digit 14 - Fresh Air Selection**

0 = No Fresh Air

A = Manual Outside Air Damper 0-50%

B = Motorized Outside Air Damper 0-50%

C = Economizer, Dry Bulb 0-100%

without Barometric Relief

D = Economizer, Dry Bulb 0-100%

with Barometric Relief

E = Economizer, Reference Enthalpy

0-100% without Barometric Relief

F = Economizer, Reference Enthalpy

0-100% with Barometric Relief

G = Economizer, Comparative Enthalpy

0-100% without Barometric Relief

H = Economizer, Comparative Enthalpy

0-100% with Barometric Relief

**Digit 15 - Supply Fan/Drive Type/Motor**

0 = Standard Drive

1 = Oversized Motor

**Digit 16 - Hinged Service Access/Filters**

0 = Standard Panels/Standard Filters

A = Hinged Access Panels/Standard Filters

B = Standard Panels/

50 mm (2") Pleated Filters

C = Hinged Access Panels/

50 mm (2") Pleated Filters

**Digit 17 - Condenser Coil Protection**

0 = Standard Coil

1 = Standard Coil with Hail Guard

2 = Epoxy Coated Condenser Coil

3 = Epoxy Coated Condenser Coil with

Hail Guard

**Digit 18 - Through the Base Provisions**

0 = No Through the Base Provisions

**Digit 19 - Disconnect/Circuit Breaker**

0 = No Disconnect or Circuit Breaker

**Digit 20 - Convenience Outlet**

0 = No Convenience Outlet

**Digit 21 - Communications Options**

0 = No Communications Interface

1 = Comm-3/4 Communications Interface

2 = Comm-5 Communications Interface

**Digit 22 - Refrigeration System Option**

0 = Standard Refrigeration System

**Digit 23 - Refrigeration Controls**

0 = No Refrigeration Control

**Digit 24 - Smoke Detector**

0 = No Smoke Detector

**Digit 25 - Monitoring Controls**

0 = No Monitoring Control

1 = Clogged Filter Switch

2 = Fan Failure Switch

3 = Discharge Air Sensing Tube

4 = Clogged Filter Switch and Fan Fail

Switch

5 = Clogged Filter Switch and Discharge

Air Sensing Tube

6 = Fan Fail Switch and Discharge Air

Sensing Tube

7 = Clogged Filter and Fan Fail Switches

and Discharge Air Sensing Tube

# General Data

**Table GD - 1 — General Data**

	Convertible Units TSC060AD	Convertible Units TSC072AD	Convertible Units TSC090AD	Convertible Units TSC102AD	Convertible Units TSC120AD
<b>Cooling Performance <sup>1</sup></b>					
Gross Capacity - kW (MBh)	18.2 (62.0)	23.2 (79.0)	26.7 (91.0)	31.1 (106.0)	34.9 (119.0)
COP (EER) <sup>2</sup>	2.99 (10.2)	3.08 (10.5)	3.02 (10.3)	3.02 (10.3)	2.99 (10.2)
Nominal Airflow - m <sup>3</sup> /h (cfm)	3400 (2000)	4080 (2400)	5100 (3000)	5780 (3400)	6800 (4000)
Rated Airflow - m <sup>3</sup> /h (cfm)	3400 (2000)	3570 (2100)	4460 (2625)	5100 (3000)	5950 (3500)
Net Capacity - kW (MBh)	17.3 (59.0)	22.0 (75.0)	25.2 (86.0)	29.9 (102.0)	33.1 (113.0)
System Power - kW	5.78	7.14	8.35	9.90	11.08
<b>Compressor</b>					
Number - Type	1-Climatuff Scroll	1-Trane 3-D Scroll	1-Trane 3-D Scroll	2-Climatuff Scroll	2-Climatuff Scroll
<b>Outdoor Sound Rating - dB<sup>3</sup></b>	80	85	85	83	79
<b>Outdoor Coil - Type</b>					
Tube Size - in. OD	Lanced	Lanced	Lanced	Lanced	Lanced
Face Area - m <sup>2</sup> (sq ft)	0.3125	0.3125	0.3125	0.3125	0.3125
Rows / FPI	1.02 (10.96)	1.29 (13.88)	1.29 (13.88)	1.75 (18.89)	2.41 (25.92)
<b>Indoor Coil - Type</b>					
Tube Size OD - in.	Lanced	Lanced	Lanced	Lanced	Lanced
Face Area - m <sup>2</sup> (sq ft)	0.3125	0.3125	0.3125	0.3125	0.3125
Rows / FPI	0.62 (6.68)	0.92 (9.89)	0.92 (9.89)	1.15 (12.36)	1.15 (12.36)
Refrigerant Control	3 / 16	2 / 16	3 / 16	3 / 16	4 / 16
Drain Connection No. / Size - in.	Short Orifice	Short Orifice	Short Orifice	Short Orifice	Short Orifice
<b>Outdoor Fan - Type</b>					
No. Used / Diameter - in.	1 / 0.75 NPT	1 / 0.75 NPT	1 / 0.75 NPT	1 / 0.75 NPT	1 / 0.75 NPT
Drive Type / No. Speeds	Propeller	Propeller	Propeller	Propeller	Propeller
CFM	1 / 22	1 / 26	1 / 26	1 / 26	1 / 26
No. Motors / kW (HP)	Direct / 1	Direct / 1	Direct / 1	Direct / 1	Direct / 1
Motor RPM	2900	5100	5200	5500	5800
<b>Belt Drive Indoor Fan - Type</b>					
No. Used	1 / 0.30 (0.40)	1 / .56 (0.75)	1 / .56 (0.75)	1 / .56 (0.75)	1 / .56 (0.75)
Fan Diameter x Width - mm (in.)	950	950	950	950	950
Drive Type / No. Speeds	FC Centrifugal	FC Centrifugal	FC Centrifugal	FC Centrifugal	FC Centrifugal
No. Motors	1	1	1	1	1
Standard Motor Power - kW (HP)	280 X 280 (11 x 11)	305 X 305 (12 x 12)	305 X 305 (12 x 12)	381 X 381 (15 x 15)	381 X 381 (15 x 15)
Oversized Motor Power - kW (HP)	Belt / Variable Speed	Belt / Variable Speed	Belt / Variable Speed	Belt / Variable Speed	Belt / Variable Speed
Motor RPM - Standard / Oversized	1	1	1	1	1
Motor Frame Size	1.1 (1.5)	1.1 (1.5)	1.5 (2.0)	1.5 (2.0)	2.2 (3.0)
<b>Filters - Type Furnished</b>					
(No.) Size Recommended - mm	1450 / -	1450 / 1450	1450 / 2850	1450 / 2850	2850 / -
(No.) Size Recommended - in.	56	56	56	56	56
<b>Refrigerant Charge - kg (lbs) of R-22<sup>4</sup></b>					
	Throwaway	Throwaway	Throwaway	Throwaway	Throwaway
	(2) 508 X 762 X 25	(4) 406 X 635 X 50	(4) 406 X 635 X 50	(4) 508 X 635 X 50	(4) 508 X 635 X 50
	(2) 20 X 30 X 1	(4) 16 X 25 X 2	(4) 16 X 25 X 2	(4) 20 X 25 X 2	(4) 20 X 25 X 2
	3.7 (8.2)	3.7 (8.2)	4.5 (10.0)	Circuit 1 - 3.8 (8.3) Circuit 2 - 2.0 (4.4)	Circuit 1 - 3.4 (7.5) Circuit 2 - 3.3 (7.3)

**Notes:**

- Cooling Performance is rated at 35.0 C (95 F) ambient, 26.7 C (80 F) entering dry bulb, 19.4 C (67 F) entering wet bulb. Gross capacity does not include the effect of fan motor heat. Net capacity includes the effect of fan motor heat. Units are suitable for operation to ± 20 % of nominal airflow.
- EER are rated at ARI conditions.
- Outdoor Sound rating shown is tested in accordance with ARI Standard 270. For more information refer to Performance Data Table "Sound Power Level".
- Refrigerant charge is an approximate value. For a more precise value, see unit nameplate and service literature.















# Performance Data

**Table PD-6 — Belt Drive Evaporator Fan Performance - TSC060AD - Downflow Configuration (SI)**

m³/h	External Static Pressure (Pascals)																			
	25		50		75		100		125		150		175		200		225		250	
	RPM	kW	RPM	kW	RPM	kW	RPM	kW	RPM	kW	RPM	kW	RPM	kW	RPM	kW	RPM	kW	RPM	kW
1.12 Nom kW Standard Motor & Low Static Drive										1.12 Nom kW Standard Motor & Drive										
2720	-	-	703	0.27	757	0.31	806	0.35	854	0.39	899	0.43	944	0.49	985	0.54	1023	0.59	1060	0.64
3060	706	0.32	760	0.35	815	0.40	861	0.45	904	0.49	947	0.54	988	0.58	1028	0.64	1067	0.70	1104	0.76
3400	773	0.43	821	0.46	873	0.51	918	0.57	958	0.62	998	0.67	1036	0.71	1073	0.76	1111	0.82	1147	0.89
3740	840	0.56	885	0.60	930	0.65	977	0.71	1016	0.77	1053	0.82	1089	0.88	1124	0.93	1158	0.98	1191	1.03
4080	909	0.71	950	0.76	990	0.80	1034	0.87	1074	0.93	1110	1.00	1143	1.06	1177	1.12	1209	1.17	1241	1.23

CFM	External Static Pressure (Pascals)									
	275		300		325		350		375	
	RPM	kW	RPM	kW	RPM	kW	RPM	kW	RPM	kW
1.12 Nom kW Standard Motor & Drive										
2720	1093	0.69	1126	0.74	1160	0.79	1190	0.84	1222	0.90
3060	1138	0.82	1171	0.87	1203	0.93	1232	0.98	1262	1.04
3400	1182	0.96	1215	1.02	1246	1.09	1276	1.15	1306	1.21
3740	1226	1.10	1258	1.17	1290	1.25	-	-	-	-
4080	1272	1.29	-	-	-	-	-	-	-	-

← 1.12 Nom kW Standard Motor & Hi Static Drive

**Notes:**

Data Includes Pressure Drop Due To Wet Coils And Filters.  
 1.12 kW - Fan Motor Heat (kW) = 1.144 x Fan kW + 0.132

Factory Supplied Motors, In Commercial Equipment, Are Definite Purpose Motors, Specifically Designed And Tested To Operate Reliably And Continuously At All Cataloged Conditions. Using The Full Horsepower Range Of Our Fan Motors As Shown In Our Tabular Data Will Not Result In Nuisance Tripping Or Premature Motor Failure. Our Product's Warranty Will Not Be Affected.

**Table PD-6a — Belt Drive Evaporator Fan Performance - TSC060AD - Downflow Configuration (IP)**

CFM	External Static Pressure (Inches of Water)																			
	.10		.20		.30		.40		.50		.60		.70		.80		.90		1.00	
	RPM	BHP	RPM	BHP	RPM	BHP	RPM	BHP	RPM	BHP	RPM	BHP	RPM	BHP	RPM	BHP	RPM	BHP	RPM	BHP
1-1/2 HP Standard Motor & Low Static Drive								1-1/2 HP Standard Motor & Drive												
1600	-	-	703	0.36	757	0.41	806	0.47	854	0.52	899	0.58	944	0.65	985	0.73	1023	0.79	1060	0.86
1800	706	0.42	760	0.47	815	0.54	861	0.60	904	0.66	947	0.72	988	0.78	1028	0.86	1067	0.94	1104	1.02
2000	773	0.57	821	0.62	873	0.69	918	0.76	958	0.83	998	0.90	1036	0.96	1073	1.02	1111	1.10	1147	1.19
2200	840	0.75	885	0.80	930	0.87	977	0.95	1016	1.03	1053	1.10	1089	1.17	1124	1.24	1158	1.31	1191	1.39
2400	909	0.96	950	1.02	990	1.08	1034	1.16	1074	1.25	1110	1.34	1143	1.419	1177	1.50	1209	1.57	1241	1.65

CFM	External Static Pressure (Inches of Water)									
	1.10		1.20		1.30		1.40		1.50	
	RPM	BHP	RPM	BHP	RPM	BHP	RPM	BHP	RPM	BHP
1-1/2 HP Standard Motor & Drive										
1600	1093	0.92	1126	0.99	1160	1.06	1190	1.13	1222	1.20
1800	1138	1.10	1171	1.17	1203	1.25	1232	1.32	1262	1.39
2000	1182	1.28	1215	1.37	1246	1.46	1276	1.54	1306	1.62
2200	1226	1.48	1258	1.57	1290	1.67	-	-	-	-
2400	1272	1.73	-	-	-	-	-	-	-	-

← 1-1/2 HP Standard Motor & Hi Static Drive

**Notes:**

Data Includes Pressure Drop Due To Wet Coils And Filters.  
 1 1/2 HP - Fan Motor Heat (MBH) = 2.915 x Fan BHP + 0.451

Factory Supplied Motors, In Commercial Equipment, Are Definite Purpose Motors, Specifically Designed And Tested To Operate Reliably And Continuously At All Cataloged Conditions. Using The Full Horsepower Range Of Our Fan Motors As Shown In Our Tabular Data Will Not Result In Nuisance Tripping Or Premature Motor Failure. Our Product's Warranty Will Not Be Affected.



# Performance Data

**Table PD-7 - Belt Drive Evaporator Fan Performance- TSC060AD - Horizontal Configuration - (SI)**

m <sup>3</sup> /h	External Static Pressure (Pascals)																					
	25		50		75		100		125		150		175		200		225		250			
RPM	kW	RPM	kW	RPM	kW	RPM	kW	RPM	kW	RPM	kW	RPM	kW	RPM	kW	RPM	kW	RPM	kW	RPM	kW	
1.12 Nom kW Std Motor & Low Static Drive											1.12 Nom kW Standard Motor & Drive											
2720	707	0.26	774	0.31	837	0.37	898	0.43	953	0.48	1001	0.54	1045	0.59	1087	0.65	1129	0.71	1168	0.77		
3060	778	0.36	840	0.41	897	0.48	953	0.54	1008	0.60	1058	0.67	1102	0.73	1143	0.79	1181	0.85	1219	0.92		
3400	850	0.48	908	0.54	961	0.60	1012	0.67	1062	0.74	1111	0.81	1157	0.88	1198	0.95	1237	1.02	1274	1.09		
3740	923	0.63	978	0.69	1028	0.76	1075	0.83	1120	0.91	1166	0.99	1211	1.06	1254	1.14	1294	1.22	1330	1.29		
4080	997	0.80	1049	0.87	1096	0.94	1140	1.02	1183	1.10	1223	1.18	1266	1.27	-	-	-	-	-	-	-	-

1.12 Nom kW Standard Motor & Hi Static Drive

CFM	External Static Pressure (Pascals)										
	275		300		325		350		375		
RPM	kW	RPM	kW	RPM	kW	RPM	kW	RPM	kW	RPM	kW
1.12 Nom kW Standard Motor & Drive						1.12 Nom kW Standard Motor & Hi Static Drive					
2720	1206	0.83	1241	0.89	1275	0.96	1306	1.02	1338	1.09	
3060	1256	0.99	1291	1.05	1326	1.12	1359	1.19	1390	1.26	
3400	1309	1.16	1343	1.24	1376	1.31	-	-	-	-	
3740	-	-	-	-	-	-	-	-	-	-	
4080	-	-	-	-	-	-	-	-	-	-	

1.12 Nom kW Standard Motor & Hi Static Drive

**Notes:**

Data Includes Pressure Drop Due To Wet Coils And Filters.  
1.12 kW - Fan Motor Heat (kW) = 1.144 x Fan kW + 0.132

Factory Supplied Motors, In Commercial Equipment, Are Definite Purpose Motors, Specifically Designed And Tested To Operate Reliably And Continuously At All Cataloged Conditions. Using The Full Horsepower Range Of Our Fan Motors As Shown In Our Tabular Data Will Not Result In Nuisance Tripping Or Premature Motor Failure. Our Product's Warranty Will Not Be Affected.

**Table PD-7a - Belt Drive Evaporator Fan Performance- TSC060AD - Horizontal Configuration - (IP)**

CFM	External Static Pressure (Inches of Water)																					
	0.10		0.20		0.30		0.40		0.50		0.60		0.70		0.80		0.90		1.00			
RPM	BHP	RPM	BHP	RPM	BHP	RPM	BHP	RPM	BHP	RPM	BHP	RPM	BHP	RPM	BHP	RPM	BHP	RPM	BHP	RPM	BHP	
1-1/2 HP Standard Motor & Low Static Drive								1-1/2 HP Standard Motor & Drive														
1600	707	0.35	774	0.42	837	0.50	898	0.57	953	0.65	1001	0.72	1045	0.80	1087	0.87	1129	0.95	1168	1.03		
1800	778	0.48	840	0.56	897	0.64	953	0.72	1008	0.81	1058	0.89	1102	0.98	1143	1.06	1181	1.15	1219	1.23		
2000	850	0.65	908	0.73	961	0.81	1012	0.90	1062	1.00	1111	1.09	1157	1.19	1198	1.28	1237	1.37	1274	1.47		
2200	923	0.84	978	0.93	1028	1.02	1075	1.12	1120	1.22	1166	1.32	1211	1.43	1254	1.53	1294	1.63	1330	1.74		
2400	997	1.07	1049	1.17	1096	1.27	1140	1.37	1183	1.48	1223	1.59	1266	1.70	-	-	-	-	-	-	-	-

1-1/2 HP Standard Motor & Hi Static Drive

CFM	External Static Pressure (Inches of Water)										
	1.10		1.20		1.30		1.40		1.50		
RPM	BHP	RPM	BHP	RPM	BHP	RPM	BHP	RPM	BHP	RPM	BHP
1/2 HP Standard Motor & Drive						1-1/2 HP Standard Motor & Hi Static Drive					
1600	1206	1.12	1241	1.20	1275	1.28	1306	1.37	1338	1.46	
1800	1256	1.32	1291	1.41	1326	1.50	1359	1.60	1390	1.69	
2000	1309	1.56	1343	1.66	1376	1.76	-	-	-	-	
2200	-	-	-	-	-	-	-	-	-	-	
2400	-	-	-	-	-	-	-	-	-	-	

**Notes:**

Data Includes Pressure Drop Due To Wet Coils And Filters.  
1 1/2 HP - Fan Motor Heat (MBH) = 2.915 x Fan BHP + 0.451

Factory Supplied Motors, In Commercial Equipment, Are Definite Purpose Motors, Specifically Designed And Tested To Operate Reliably And Continuously At All Cataloged Conditions. Using The Full Horsepower Range Of Our Fan Motors As Shown In Our Tabular Data Will Not Result In Nuisance Tripping Or Premature Motor Failure. Our Product's Warranty Will Not Be Affected.



# Performance Data

**Table PD-8 — Belt Drive Evaporator Fan Performance -TSC072AD - Downflow Configuration (S)**

m³/h	External Static Pressure (Pascals)																			
	25		50		75		100		125		150		175		200		225		250	
	RPM	kW	RPM	kW	RPM	kW	RPM	kW	RPM	kW	RPM	kW	RPM	kW	RPM	kW	RPM	kW	RPM	kW
1.12 Nom kW Standard Motor & Low Static Drive										1.12 Nom kW Standard Motor & Drive										
3260	-	-	-	-	573	0.25	630	0.30	680	0.36	726	0.41	769	0.47	811	0.52	851	0.58	889	0.65
3670	-	-	548	0.26	602	0.31	656	0.37	706	0.43	751	0.49	792	0.55	832	0.61	871	0.67	908	0.74
4080	-	-	584	0.33	635	0.38	682	0.45	732	0.51	777	0.58	818	0.64	856	0.71	893	0.77	930	0.84
4490	569	0.35	621	0.42	670	0.47	715	0.54	758	0.60	802	0.68	845	0.75	883	0.82	919	0.89	953	0.96
4890	612	0.45	660	0.51	706	0.58	749	0.64	789	0.71	830	0.79	870	0.87	909	0.95	945	1.02	979	1.10

CFM	External Static Pressure (Pascals)									
	275		300		325		350		375	
	RPM	kW	RPM	kW	RPM	kW	RPM	kW	RPM	kW
1.12 Nom kW Std Motor & Drive					1.12 Nom kW Standard Motor & Hi Static Drive					
3260	925	0.71	960	0.77	994	0.83	1026	0.89	1057	0.95
3670	944	0.81	978	0.87	1010	0.94	1043	1.01	1073	1.08
4080	964	0.91	998	0.99	1030	1.06	1063	1.14	1092	1.21
4490	986	1.04	1019	1.11	1051	1.19	1082	1.27	1112	1.35
4890	1011	1.18	1043	1.26	1073	1.34	1103	1.42	1133	1.51

1.12 Nom kW Standard Motor & Hi Static Drive ↗

**Notes:**

Data Includes Pressure Drop Due To Wet Coils And Filters.  
 1.12 kW - Fan Motor Heat (kW) = 1.144 x Fan kW + 0.132  
 1.50 kW - Fan Motor Heat (kW) = 1.178 x Fan kW + 0.464

Factory Supplied Motors, In Commercial Equipment, Are Definite Purpose Motors, Specifically Designed And Tested To Operate Reliably And Continuously At All Cataloged Conditions. Using The Full Horsepower Range Of Our Fan Motors As Shown In Our Tabular Data Will Not Result In Nuisance Tripping Or Premature Motor Failure. Our Product's Warranty Will Not Be Affected.

**Table PD-8a — Belt Drive Evaporator Fan Performance -TSC072AD - Downflow Configuration (IP)**

CFM	External Static Pressure (Inches of Water)																			
	.10		.20		.30		.40		.50		.60		.70		.80		.90		1.00	
	RPM	BHP	RPM	BHP	RPM	BHP	RPM	BHP	RPM	BHP	RPM	BHP	RPM	BHP	RPM	BHP	RPM	BHP	RPM	BHP
1-1/2 HP Standard Motor & Low Static Drive										1-1/2 HP Standard Motor & Drive										
1920	-	-	-	-	573	0.34	630	0.41	680	0.48	726	0.55	769	0.62	811	0.70	851	0.78	889	0.87
2160	-	-	548	0.35	602	0.42	656	0.50	706	0.58	751	0.65	792	0.73	832	0.81	871	0.90	908	0.99
2400	-	-	584	0.45	635	0.52	682	0.60	732	0.69	777	0.77	818	0.86	856	0.95	893	1.04	930	1.13
2640	569	0.47	621	0.56	670	0.64	715	0.72	758	0.81	802	0.91	845	1.01	883	1.10	919	1.20	953	1.29
2880	612	0.60	660	0.69	706	0.78	749	0.86	789	0.96	830	1.06	870	1.16	909	1.27	945	1.37	979	1.48

CFM	External Static Pressure (Inches of Water)									
	1.10		1.20		1.30		1.40		1.50	
	RPM	BHP	RPM	BHP	RPM	BHP	RPM	BHP	RPM	BHP
1-1/2 HP Standard Mtr & Drive					1-1/2 HP Standard Motor & Hi Static Drive					
1920	925	0.95	960	1.03	994	1.11	1026	1.19	1057	1.27
2160	944	1.08	978	1.17	1010	1.26	1043	1.36	1073	1.44
2400	964	1.22	998	1.32	1030	1.42	1063	1.53	1092	1.63
2640	986	1.39	1019	1.49	1051	1.60	1082	1.71	1112	1.81
2880	1011	1.58	1043	1.69	1073	1.79	1103	1.90	1133	2.02

1-1/2 HP Standard Motor & Hi Static Drive ↗

← 1-1/2 HP Standard Motor & Hi Static Drive

**Notes:**

Data Includes Pressure Drop Due To Wet Coils And Filters.  
 1 1/2 HP - Fan Motor Heat (MBH) = 2.915 x Fan BHP + 0.451  
 2 HP - Fan Motor Heat (MBH) = 3.000 x Fan BHP + 0.500

Factory Supplied Motors, In Commercial Equipment, Are Definite Purpose Motors, Specifically Designed And Tested To Operate Reliably And Continuously At All Cataloged Conditions. Using The Full Horsepower Range Of Our Fan Motors As Shown In Our Tabular Data Will Not Result In Nuisance Tripping Or Premature Motor Failure. Our Product's Warranty Will Not Be Affected.



# Performance Data

**Table PD-9 — Belt Drive Evaporator Fan Performance -TSC072AD - Horizontal Configuration (SI)**

m³/h	External Static Pressure (Pascals)																			
	25		50		75		100		125		150		175		200		225		250	
	RPM	kW	RPM	kW	RPM	kW	RPM	kW	RPM	kW	RPM	kW	RPM	kW	RPM	kW	RPM	kW	RPM	kW
<b>1.12 Nom kW Standard Motor &amp; Low Static Drive</b>										<b>1.12 Nom kW Standard Motor &amp; Drive</b>										
3260	-	-	565	0.23	627	0.29	679	0.34	726	0.39	771	0.45	814	0.51	857	0.57	899	0.63	939	0.70
3670	566	0.26	609	0.31	663	0.36	716	0.42	762	0.48	804	0.54	843	0.60	883	0.67	922	0.74	960	0.81
4080	619	0.35	660	0.40	701	0.45	751	0.51	798	0.59	839	0.65	877	0.71	914	0.78	950	0.85	984	0.93
4490	672	0.45	710	0.51	745	0.56	788	0.62	833	0.69	875	0.77	914	0.85	949	0.91	984	0.98	1016	1.06
4890	726	0.58	762	0.64	795	0.70	828	0.76	869	0.82	911	0.91	950	0.99	986	1.07	1019	1.14	1051	1.22
<b>1.12 Nom kW Standard Motor &amp; Drive</b>										<b>1.12 Nom kW Standard Motor &amp; Hi Static Drive</b>										

CFM	External Static Pressure (Pascals)									
	275		300		325		350		375	
	RPM	kW	RPM	kW	RPM	kW	RPM	kW	RPM	kW
<b>1.12 Nom kW Standard Motor &amp; Hi Static Drive</b>										
3260	978	0.76	1015	0.83	1051	0.90	1086	0.97	1118	1.04
3670	996	0.87	1034	0.95	1069	1.02	1103	1.09	1136	1.17
4080	1020	1.00	1055	1.08	1089	1.16	1122	1.23	1154	1.31
4490	1049	1.14	1081	1.23	1113	1.31	1144	1.40	1176	1.48
4890	1081	1.30	1112	1.38	1141	1.47	1170	1.57	1199	1.66
<b>1.50 Nom kW Over-Sized Motor &amp; Hi Static Drive</b>										

Notes:  
 Data Includes Pressure Drop Due To Wet Coils And Filters.  
 1.12 kW - Fan Motor Heat (kW) = 1.144 x Fan kW + 0.132  
 1.50 kW - Fan Motor Heat (kW) = 1.178 x Fan kW + 0.464

Factory Supplied Motors, In Commercial Equipment, Are Definite Purpose Motors, Specifically Designed And Tested To Operate Reliably And Continuously At All Cataloged Conditions. Using The Full Horsepower Range Of Our Fan Motors As Shown In Our Tabular Data Will Not Result In Nuisance Tripping Or Premature Motor Failure. Our Product's Warranty Will Not Be Affected.

**Table PD-9a — Belt Drive Evaporator Fan Performance -TSC072AD - Horizontal Configuration (IP)**

CFM	External Static Pressure (Inches of Water)																			
	.10		.20		.30		.40		.50		.60		.70		.80		.90		1.00	
	RPM	BHP	RPM	BHP	RPM	BHP	RPM	BHP	RPM	BHP	RPM	BHP	RPM	BHP	RPM	BHP	RPM	BHP	RPM	BHP
<b>1-1/2 HP Standard Motor &amp; Low Static Drive</b>									<b>1-1/2 HP Standard Motor &amp; Drive</b>											
1920	-	-	565	0.31	627	0.39	679	0.45	726	0.52	771	0.60	814	0.69	857	0.77	899	0.85	939	0.93
2160	566	0.35	609	0.41	663	0.48	716	0.57	762	0.64	804	0.72	843	0.80	883	0.90	922	0.99	960	1.08
2400	619	0.47	660	0.54	701	0.60	751	0.69	798	0.78	839	0.87	877	0.95	914	1.04	950	1.14	984	1.24
2640	672	0.61	710	0.68	745	0.76	788	0.83	833	0.93	875	1.04	914	1.13	949	1.22	984	1.31	1016	1.42
2880	726	0.77	762	0.86	795	0.94	828	1.02	869	1.11	911	1.21	950	1.33	986	1.44	1019	1.53	1051	1.63
<b>1-1/2 HP Standard Motor &amp; Drive</b>									<b>1-1/2 HP Std Motor &amp; Hi Static Drive</b>											

CFM	External Static Pressure (Inches of Water)									
	1.10		1.20		1.30		1.40		1.50	
	RPM	BHP	RPM	BHP	RPM	BHP	RPM	BHP	RPM	BHP
<b>1-1/2 HP Standard Motor &amp; Hi Static Drive</b>										
1920	978	1.02	1015	1.11	1051	1.20	1086	1.30	1118	1.39
2160	996	1.17	1034	1.27	1069	1.36	1103	1.46	1136	1.56
2400	1020	1.35	1055	1.45	1089	1.55	1122	1.66	1154	1.76
2640	1049	1.53	1081	1.65	1113	1.76	1144	1.87	1176	1.98
2880	1081	1.74	1112	1.86	1141	1.97	1170	2.10	1199	2.22
<b>2 HP Over-Sized Motor &amp; High Static Drive</b>										

Notes:  
 Data Includes Pressure Drop Due To Wet Coils And Filters.  
 1 1/2 HP - Fan Motor Heat (MBH) = 2.915 x Fan BHP + 0.451  
 2 HP - Fan Motor Heat (MBH) = 3.000 x Fan BHP + 0.500

Factory Supplied Motors, In Commercial Equipment, Are Definite Purpose Motors, Specifically Designed And Tested To Operate Reliably And Continuously At All Cataloged Conditions. Using The Full Horsepower Range Of Our Fan Motors As Shown In Our Tabular Data Will Not Result In Nuisance Tripping Or Premature Motor Failure. Our Product's Warranty Will Not Be Affected.



# Performance Data

**Table PD-10 — Belt Drive Evaporator Fan Performance -TSC090AD - Downflow Configuration (SI)**

m³/h	External Static Pressure (Pascals)																			
	25		50		75		100		125		150		175		200		225		250	
	RPM	kW	RPM	kW	RPM	kW	RPM	kW	RPM	kW	RPM	kW	RPM	kW	RPM	kW	RPM	kW	RPM	kW
<b>1.50 Nom kW Standard Motor &amp; Low Static Drive</b>									<b>1.50 Nom kW Standard Motor &amp; Drive</b>											
4080	-	-	-	-	-	-	701	0.47	750	0.54	794	0.60	834	0.67	873	0.73	909	0.80	945	0.87
4590	-	-	-	-	699	0.53	743	0.59	787	0.66	830	0.74	871	0.82	908	0.89	943	0.96	977	1.04
5100	-	-	703	0.61	747	0.68	789	0.74	827	0.82	867	0.90	906	0.98	944	1.06	980	1.15	1013	1.23
5610	713	0.69	755	0.77	797	0.85	836	0.92	873	1.00	908	1.08	944	1.17	980	1.26	1016	1.35	1050	1.45
6120	771	0.88	809	0.96	848	1.06	885	1.14	921	1.22	954	1.30	986	1.39	1019	1.49	1052	1.58	1085	1.69

1.50 Nom kW Standard Motor & Hi Static Drive ↗

CFM	External Static Pressure (Pascals)									
	275		300		325		350		375	
	RPM	kW	RPM	kW	RPM	kW	RPM	kW	RPM	kW
<b>1.50 Nom kW Std Motor &amp; Drive</b>					<b>1.50 Nom kW Standard Motor &amp; Hi Static Drive</b>					
4080	980	0.95	1013	1.02	1046	1.10	1076	1.17	1106	1.25
4590	1010	1.11	1043	1.19	1074	1.27	1105	1.36	1134	1.44
5100	1045	1.31	1076	1.39	1105	1.47	1134	1.56	1163	1.65
5610	1081	1.54	1111	1.63	1141	1.72	1168	1.80	1197	1.90
6120	1116	1.79	1148	1.89	1177	1.99	1204	2.08	1232	2.18

2.24 Nom kW Over-Sized Motor & Hi Static Drive

Notes:  
 Data Includes Pressure Drop Due To Wet Coils And Filters.  
 1.50 kW - Fan Motor Heat (kW) = 1.178 x Fan kW + 0.464  
 2.24 kW - Fan Motor Heat (kW) = 1.138 x Fan kW + 0.139

Factory Supplied Motors, In Commercial Equipment, Are Definite Purpose Motors, Specifically Designed And Tested To Operate Reliably And Continuously At All Cataloged Conditions. Using The Full Horsepower Range Of Our Fan Motors As Shown In Our Tabular Data Will Not Result In Nuisance Tripping Or Premature Motor Failure. Our Product's Warranty Will Not Be Affected.

**Table PD-10a — Belt Drive Evaporator Fan Performance -TSC090AD - Downflow Configuration (IP)**

CFM	External Static Pressure (Inches of Water)																			
	.10		.20		.30		.40		.50		.60		.70		.80		.90		1.00	
	RPM	BHP	RPM	BHP	RPM	BHP	RPM	BHP	RPM	BHP	RPM	BHP	RPM	BHP	RPM	BHP	RPM	BHP	RPM	BHP
<b>2 HP Standard Motor &amp; Low Static Drive</b>								<b>2 HP Standard Motor &amp; Drive</b>												
2400	-	-	-	-	-	-	701	0.63	750	0.72	794	0.81	834	0.90	873	0.98	909	1.08	945	1.17
2700	-	-	-	-	699	0.70	743	0.79	787	0.89	830	0.99	871	1.09	908	1.19	943	1.29	977	1.39
3000	-	-	703	0.81	747	0.91	789	0.99	827	1.10	867	1.20	906	1.31	944	1.43	980	1.54	1013	1.65
3300	713	0.93	755	1.03	797	1.15	836	1.24	873	1.34	908	1.45	944	1.57	980	1.69	1016	1.82	1050	1.94
3600	771	1.19	809	1.29	848	1.42	885	1.53	921	1.63	954	1.74	986	1.87	1019	1.99	1052	2.13	1085	2.26

2 HP Standard Motor & Hi Static Drive ↗

CFM	External Static Pressure (Inches of Water)									
	1.10		1.20		1.30		1.40		1.50	
	RPM	BHP	RPM	BHP	RPM	BHP	RPM	BHP	RPM	BHP
<b>2 HP Standard Mtr &amp; Drive</b>					<b>2 HP Standard Motor &amp; Hi Static Drive</b>					
2400	980	1.27	1013	1.37	1046	1.47	1076	1.57	1106	1.68
2700	1010	1.49	1043	1.60	1074	1.71	1105	1.82	1134	1.93
3000	1045	1.76	1076	1.87	1105	1.98	1134	2.09	1163	2.21
3300	1081	2.06	1111	2.18	1141	2.30	1168	2.42	1197	2.55
3600	1116	2.39	1148	2.53	1177	2.66	1204	2.79	1232	2.93

3 HP Over-Sized Mtr & Hi Static Drive

Notes:  
 Data Includes Pressure Drop Due To Wet Coils And Filters.  
 2 HP - Fan Motor Heat (MBH) = 3.000 x Fan BHP + 0.500  
 3 HP - Fan Motor Heat (MBH) = 2.900 x Fan BHP + 0.475

Factory Supplied Motors, In Commercial Equipment, Are Definite Purpose Motors, Specifically Designed And Tested To Operate Reliably And Continuously At All Cataloged Conditions. Using The Full Horsepower Range Of Our Fan Motors As Shown In Our Tabular Data Will Not Result In Nuisance Tripping Or Premature Motor Failure. Our Product's Warranty Will Not Be Affected.



# Performance Data

**Table PD-11 — Belt Drive Evaporator Fan Performance -TSC090AD - Horizontal Configuration (SI)**

		External Static Pressure (Pascals)																			
		25		50		75		100		125		150		175		200		225		250	
m <sup>3</sup> /h		RPM	kW	RPM	kW	RPM	kW	RPM	kW	RPM	kW	RPM	kW	RPM	kW	RPM	kW	RPM	kW	RPM	kW
<b>1.50 Nom kW Std Motor &amp; Low Static Drive</b>											<b>1.50 Nom kW Standard Motor &amp; Drive</b>										
4080	-	-	-	673	0.42	718	0.47	769	0.54	814	0.61	855	0.67	893	0.73	929	0.81	965	0.88	999	0.96
4590	702	0.51	738	0.56	773	0.62	817	0.68	862	0.76	904	0.85	941	0.92	975	0.98	1009	1.06	1041	1.14	
5100	771	0.68	805	0.74	837	0.81	870	0.87	912	0.94	951	1.03	989	1.12	1025	1.21	1056	1.28	1088	1.36	
5610	842	0.89	873	0.96	903	1.03	930	1.10	963	1.17	1000	1.25	1037	1.34	1073	1.45	1106	1.55	1136	1.63	
6120	913	1.14	942	1.22	970	1.30	996	1.37	1021	1.45	1052	1.52	1086	1.61	1121	1.71	1153	1.82	1184	1.93	
<b>1.50 Nom kW Standard Motor &amp; Drive</b>											<b>1.50 Nom kW Standard Motor &amp; Hi Static Drive</b>					<b>2.24 Nom kW OS Motor &amp; Hi Static Drive</b>					

		External Static Pressure (Pascals)									
		275		300		325		350		375	
CFM		RPM	kW	RPM	kW	RPM	kW	RPM	kW	RPM	kW
<b>1.50 Nom kW Standard Motor &amp; Hi Static Drive</b>											
4080	1035	1.04	1070	1.12	1104	1.19	1137	1.27	1168	1.35	
4590	1073	1.22	1104	1.31	1136	1.40	1167	1.48	1198	1.57	
5100	1117	1.44	1146	1.53	1176	1.62	1205	1.72	1233	1.82	
5610	1165	1.72	1194	1.80	1220	1.88	1248	1.98	1275	2.08	
6120	1215	2.04	1242	2.13	1269	2.22	1295	2.31	1319	2.40	
<b>2.24 Nom kW Over-Sized Motor &amp; Hi Static Drive</b>											

Notes:  
 Data Includes Pressure Drop Due To Wet Coils And Filters.  
 1.50 kW - Fan Motor Heat (kW) = 1.178 x Fan kW + 0.464  
 2.24 kW - Fan Motor Heat (kW) = 1.138 x Fan kW + 0.139

Factory Supplied Motors, In Commercial Equipment, Are Definite Purpose Motors, Specifically Designed And Tested To Operate Reliably And Continuously At All Cataloged Conditions. Using The Full Horsepower Range Of Our Fan Motors As Shown In Our Tabular Data Will Not Result In Nuisance Tripping Or Premature Motor Failure. Our Product's Warranty Will Not Be Affected.

**Table PD-11a — Belt Drive Evaporator Fan Performance -TSC090AD - Horizontal Configuration (IP)**

		External Static Pressure (Inches of Water)																			
		.10		.20		.30		.40		.50		.60		.70		.80		.90		1.00	
CFM		RPM	BHP	RPM	BHP	RPM	BHP	RPM	BHP	RPM	BHP	RPM	BHP	RPM	BHP	RPM	BHP	RPM	BHP	RPM	BHP
<b>2 HP Std Motor &amp; Low Static Drive</b>											<b>2 HP Standard Motor &amp; Drive</b>										
2400	-	-	-	673	0.56	718	0.63	769	0.72	814	0.82	855	0.90	893	0.98	929	1.08	965	1.18	999	1.29
2700	702	0.68	738	0.76	773	0.83	817	0.92	862	1.02	904	1.13	941	1.23	975	1.32	1009	1.42	1041	1.52	
3000	771	0.91	805	1.00	837	1.08	870	1.17	912	1.26	951	1.38	989	1.51	1025	1.62	1056	1.72	1088	1.82	
3300	842	1.19	873	1.29	903	1.38	930	1.47	963	1.57	1000	1.68	1037	1.80	1073	1.94	1106	2.08	1136	2.19	
3600	913	1.53	942	1.63	970	1.74	996	1.84	1021	1.94	1052	2.04	1086	2.16	1121	2.29	1153	2.44	1184	2.59	
<b>2 HP Standard Motor &amp; Drive</b>											<b>2 HP Std Motor &amp; Hi Static Drive</b>					<b>3 HP Over-Sized Motor &amp; Hi Static Drive</b>					

		External Static Pressure (Inches of Water)									
		1.10		1.20		1.30		1.40		1.50	
CFM		RPM	BHP	RPM	BHP	RPM	BHP	RPM	BHP	RPM	BHP
<b>2 HP Standard Motor &amp; Hi Static Drive</b>											
2400	1035	1.39	1070	1.50	1104	1.60	1137	1.70	1168	1.81	
2700	1073	1.64	1104	1.76	1136	1.87	1167	1.99	1198	2.11	
3000	1117	1.93	1146	2.05	1176	2.17	1205	2.31	1233	2.44	
3300	1165	2.30	1194	2.41	1220	2.52	1248	2.66	1275	2.79	
3600	1215	2.73	1242	2.86	1269	2.98	1295	3.10	1319	3.22	
<b>3 HP Over-Sized Motor &amp; High Static Drive</b>											

Notes:  
 Data Includes Pressure Drop Due To Wet Coils And Filters.  
 2 HP - Fan Motor Heat (MBH) = 3.000 x Fan BHP + 0.500  
 3 HP - Fan Motor Heat (MBH) = 2.900 x Fan BHP + 0.475

Factory Supplied Motors, In Commercial Equipment, Are Definite Purpose Motors, Specifically Designed And Tested To Operate Reliably And Continuously At All Cataloged Conditions. Using The Full Horsepower Range Of Our Fan Motors As Shown In Our Tabular Data Will Not Result In Nuisance Tripping Or Premature Motor Failure. Our Product's Warranty Will Not Be Affected.



# Performance Data

**Table PD-12 — Belt Drive Evaporator Fan Performance -TSC102AD - Downflow Configuration (SI)**

m³/h	External Static Pressure (Pascals)																				
	25		50		75		100		125		150		175		200		225		250		
	RPM	kW	RPM	kW	RPM	kW	RPM	kW	RPM	kW	RPM	kW	RPM	kW	RPM	kW	RPM	kW	RPM	kW	
<b>1.50 Nom kW Standard Motor &amp; Low Static Drive</b>											<b>1.50 Nom kW Standard Motor &amp; Drive</b>										
4620	-	-	-	-	-	-	613	0.45	655	0.54	695	0.62	733	0.71	769	0.81	802	0.90	833	1.00	
5200	-	-	-	-	611	0.48	650	0.55	688	0.64	725	0.73	761	0.83	796	0.93	828	1.03	861	1.13	
5780	-	-	612	0.51	651	0.59	689	0.68	724	0.76	759	0.86	792	0.96	825	1.07	856	1.18	887	1.28	
6350	622	0.56	659	0.64	693	0.72	729	0.82	764	0.92	795	1.01	826	1.11	857	1.22	887	1.34	916	1.46	
6930	671	0.71	706	0.80	738	0.89	770	0.98	804	1.09	834	1.19	864	1.30	892	1.40	920	1.52	948	1.64	

**1.50 Nom kW Standard Motor & Hi Static Drive**

m³/h	External Static Pressure (Pascals)																			
	275		300		325		350		375		400		425		450		475		500	
	RPM	kW	RPM	kW	RPM	kW	RPM	kW	RPM	kW	RPM	kW	RPM	kW	RPM	kW	RPM	kW	RPM	kW
<b>1.50 Nom kW Std Mtr &amp; Drive</b>								<b>1.50 Nom kW Std Mtr &amp; Hi Static Dr</b>												
4620	863	1.11	892	1.21	920	1.33	946	1.44	973	1.55	999	1.67	1025	1.79	1050	1.90	1073	2.02	1098	2.14
5200	891	1.24	919	1.35	946	1.46	973	1.58	999	1.71	1024	1.83	1048	1.96	1072	2.09	1096	2.22	1119	2.34
5780	917	1.40	946	1.51	974	1.63	1001	1.75	1026	1.88	1051	2.01	1074	2.14	1099	2.27	1121	2.41	1143	2.55
6350	945	1.58	974	1.70	1001	1.82	1028	1.95	1054	2.08	1079	2.20	1103	2.34	1126	2.48	1148	2.62	1170	2.76
6930	976	1.78	1002	1.91	1029	2.04	1055	2.17	1081	2.30	1105	2.43	1130	2.58	1154	2.72	1176	2.85	1199	3.01

**2.24 Nom kW Over-Sized Motor & High Static Drive**

**Notes:**

Data Includes Pressure Drop Due To Wet Coils And Filters.  
 1.50 kW - Fan Motor Heat (kW) = 1.178 x Fan kW + 0.464  
 2.24 kW - Fan Motor Heat (kW) = 1.138 x Fan kW + 0.139

Factory Supplied Motors, In Commercial Equipment, Are Definite Purpose Motors, Specifically Designed And Tested To Operate Reliably And Continuously At All Cataloged Conditions. Using The Full Horsepower Range Of Our Fan Motors As Shown In Our Tabular Data Will Not Result In Nuisance Tripping Or Premature Motor Failure. Our Product's Warranty Will Not Be Affected.

**Table PD-12a — Belt Drive Evaporator Fan Performance -TSC102AD - Downflow Configuration (IP)**

CFM	External Static Pressure (Inches of Water)																			
	.10		.20		.30		.40		.50		.60		.70		.80		.90		1.00	
	RPM	BHP	RPM	BHP	RPM	BHP	RPM	BHP	RPM	BHP	RPM	BHP	RPM	BHP	RPM	BHP	RPM	BHP	RPM	BHP
<b>2 HP Standard Motor &amp; Low Static Drive</b>								<b>2 HP Standard Motor &amp; Drive</b>												
2720	-	-	-	-	-	-	613	0.60	655	0.72	695	0.84	733	0.95	769	1.08	802	1.21	833	1.34
3060	-	-	-	-	611	0.64	650	0.74	688	0.85	725	0.98	761	1.11	796	1.25	828	1.38	861	1.52
3400	-	-	612	0.68	651	0.79	689	0.91	724	1.02	759	1.15	792	1.29	825	1.43	856	1.58	887	1.72
3740	622	0.76	659	0.86	693	0.97	729	1.10	764	1.23	795	1.35	826	1.49	857	1.64	887	1.79	916	1.96
4080	671	0.96	706	1.08	738	1.19	770	1.32	804	1.46	834	1.60	864	1.74	892	1.88	920	2.04	948	2.20

**2 HP Standard Motor & Hi Static Drive**

CFM	External Static Pressure (Inches of Water)																			
	1.10		1.20		1.30		1.40		1.50		1.60		1.70		1.80		1.90		2.00	
	RPM	BHP	RPM	BHP	RPM	BHP	RPM	BHP	RPM	BHP	RPM	BHP	RPM	BHP	RPM	BHP	RPM	BHP	RPM	BHP
<b>2 HP Standard Mtr &amp; Drive</b>								<b>2 HP Std Motor &amp; Hi Static Drive</b>												
2720	863	1.48	892	1.63	920	1.78	946	1.93	973	2.08	999	2.24	1025	2.39	1050	2.55	1073	2.71	1098	2.88
3060	891	1.66	919	1.81	946	1.96	973	2.12	999	2.29	1024	2.46	1048	2.63	1072	2.80	1096	2.98	1119	3.14
3400	917	1.87	946	2.03	974	2.18	1001	2.34	1026	2.52	1051	2.69	1074	2.86	1099	3.05	1121	3.23	1143	3.41
3740	945	2.11	974	2.28	1001	2.44	1028	2.61	1054	2.78	1079	2.96	1103	3.14	1126	3.32	1148	3.51	1170	3.71
4080	976	2.38	1002	2.56	1029	2.73	1055	2.91	1081	3.09	1105	3.26	1130	3.45	1154	3.65	1176	3.83	1199	4.03

**3 HP Over-Sized Motor & Drive**

**Notes:**

Data Includes Pressure Drop Due To Wet Coils And Filters.  
 2 HP - Fan Motor Heat (MBH) = 3.000 x Fan BHP + 0.500  
 3 HP - Fan Motor Heat (MBH) = 2.900 x Fan BHP + 0.475

Factory Supplied Motors, In Commercial Equipment, Are Definite Purpose Motors, Specifically Designed And Tested To Operate Reliably And Continuously At All Cataloged Conditions. Using The Full Horsepower Range Of Our Fan Motors As Shown In Our Tabular Data Will Not Result In Nuisance Tripping Or Premature Motor Failure. Our Product's Warranty Will Not Be Affected.



# Performance Data

**Table PD-13 — Belt Drive Evaporator Fan Performance -TSC102AD - Horizontal Configuration (SI)**

m³/h	External Static Pressure (Pascals)																			
	25		50		75		100		125		150		175		200		225		250	
	RPM	kW	RPM	kW	RPM	kW	RPM	kW	RPM	kW	RPM	kW	RPM	kW	RPM	kW	RPM	kW	RPM	kW
1.50 Nom kW Std Mtr & Low Static Drive										1.50 Nom kW Standard Motor & Drive										
4620	-	-	-	-	646	0.50	689	0.58	734	0.67	781	0.77	826	0.88	865	0.98	898	1.07	928	1.16
5200	616	0.51	654	0.57	693	0.64	735	0.73	773	0.82	812	0.92	855	1.03	897	1.15	934	1.27	969	1.38
5780	675	0.68	711	0.75	743	0.82	781	0.91	819	1.01	853	1.11	886	1.21	925	1.34	964	1.47	1000	1.60
6350	735	0.89	770	0.97	799	1.04	830	1.12	865	1.23	899	1.34	930	1.45	960	1.56	994	1.68	1028	1.82
6930	796	1.14	828	1.23	857	1.31	883	1.39	913	1.48	945	1.60	977	1.72	1006	1.84	1034	1.96	1061	2.08
										1.50 Nom kW Std Mtr & High Static Drive					2.24 Nom kW Over-Sized Motor & High Static Drive					

m³/h	External Static Pressure (Pascals)																			
	275		300		325		350		375		400		425		450		475		500	
	RPM	kW	RPM	kW	RPM	kW	RPM	kW	RPM	kW	RPM	kW	RPM	kW	RPM	kW	RPM	kW	RPM	kW
1.50 Nom kW Standard Motor & High Static Drive										2.24 Nom kW Over-Sized Motor & High Static Drive										
4620	956	1.25	982	1.33	1008	1.42	1033	1.51	1056	1.60	1079	1.69	1102	1.78	1125	1.87	1146	1.95	1168	2.04
5200	999	1.49	1026	1.58	1052	1.68	1078	1.78	1101	1.88	1124	1.98	1146	2.08	1168	2.18	1188	2.27	1209	2.37
5780	1034	1.73	1067	1.86	1094	1.97	1120	2.08	1145	2.20	1168	2.31	1191	2.42	1213	2.53	1234	2.63	1254	2.74
6350	1063	1.96	1098	2.11	1129	2.26	1158	2.40	1185	2.53	1210	2.66	1234	2.78	1256	2.90	1278	3.03	1299	3.15
6930	1093	2.23	1125	2.38	1157	2.53	1188	2.70	1218	2.86	1245	3.01	1273	3.16	1297	3.31	-	-	-	-

Notes:  
 Data Includes Pressure Drop Due To Wet Coils And Filters.  
 1.50 kW - Fan Motor Heat (kW) = 1.178 x Fan kW + 0.464  
 2.24 kW - Fan Motor Heat (kW) = 1.138 x Fan kW + 0.139  
 Factory Supplied Motors, In Commercial Equipment, Are Definite Purpose Motors, Specifically Designed And Tested To Operate Reliably And Continuously At All Cataloged Conditions. Using The Full Horsepower Range Of Our Fan Motors As Shown In Our Tabular Data Will Not Result In Nuisance Tripping Or Premature Motor Failure. Our Product's Warranty Will Not Be Affected.

**Table PD-13a — Belt Drive Evaporator Fan Performance -TSC102AD - Horizontal Configuration (IP)**

CFM	External Static Pressure (Inches of Water)																			
	.10		.20		.30		.40		.50		.60		.70		.80		.90		1.00	
	RPM	BHP	RPM	BHP	RPM	BHP	RPM	BHP	RPM	BHP	RPM	BHP	RPM	BHP	RPM	BHP	RPM	BHP	RPM	BHP
2 HP Std Mtr & Low Static Drive								2 HP Standard Motor & Drive												
2720	-	-	-	-	646	0.67	689	0.78	734	0.90	781	1.04	826	1.18	865	1.31	898	1.44	928	1.56
3060	616	0.69	654	0.77	693	0.86	735	0.98	773	1.10	812	1.23	855	1.39	897	1.55	934	1.70	969	1.85
3400	675	0.92	711	1.01	743	1.10	781	1.22	819	1.36	853	1.49	886	1.62	925	1.79	964	1.97	1000	2.14
3740	735	1.20	770	1.30	799	1.40	830	1.51	865	1.65	899	1.79	930	1.94	960	2.09	994	2.26	1028	2.44
4080	796	1.53	828	1.65	857	1.76	883	1.86	913	1.99	945	2.15	977	2.30	1006	2.47	1034	2.63	1061	2.79
								2 HP Std Motor & Hi Static Drive				3 HP Over-Sized Mtr & Drive								

CFM	External Static Pressure (Inches of Water)																			
	1.10		1.20		1.30		1.40		1.50		1.60		1.70		1.80		1.90		2.00	
	RPM	BHP	RPM	BHP	RPM	BHP	RPM	BHP	RPM	BHP	RPM	BHP	RPM	BHP	RPM	BHP	RPM	BHP	RPM	BHP
2 HP Standard Motor & High Static Drive								3 HP Over-Sized Motor & Drive												
2720	956	1.67	982	1.79	1008	1.91	1033	2.03	1056	2.14	1079	2.26	1102	2.38	1125	2.5	1146	2.62	1168	2.74
3060	999	1.99	1026	2.12	1052	2.26	1078	2.39	1101	2.52	1124	2.66	1146	2.79	1168	2.92	1188	3.05	1209	3.18
3400	1034	2.32	1067	2.49	1094	2.64	1120	2.79	1145	2.94	1168	3.09	1191	3.24	1213	3.39	1234	3.53	1254	3.68
3740	1063	2.63	1098	2.84	1129	3.03	1158	3.21	1185	3.39	1210	3.56	1234	3.73	1256	3.89	1278	4.06	1299	4.23
4080	1093	2.99	1125	3.19	1157	3.40	1188	3.62	1218	3.83	1245	4.03	1273	4.24	1297	4.44	-	-	-	-

Notes:  
 Data Includes Pressure Drop Due To Wet Coils And Filters.  
 2 HP - Fan Motor Heat (MBH) = 3.000 x Fan BHP + 0.500  
 3 HP - Fan Motor Heat (MBH) = 2.900 x Fan BHP + 0.475  
 Factory Supplied Motors, In Commercial Equipment, Are Definite Purpose Motors, Specifically Designed And Tested To Operate Reliably And Continuously At All Cataloged Conditions. Using The Full Horsepower Range Of Our Fan Motors As Shown In Our Tabular Data Will Not Result In Nuisance Tripping Or Premature Motor Failure. Our Product's Warranty Will Not Be Affected.



# Performance Data

**Table PD-14 — Belt Drive Evaporator Fan Performance -TSC120AD - Downflow Configuration (SI)**

m³/h	External Static Pressure (Pascals)																			
	25		50		75		100		125		150		175		200		225		250	
	RPM	kW	RPM	kW	RPM	kW	RPM	kW	RPM	kW	RPM	kW	RPM	kW	RPM	kW	RPM	kW	RPM	kW
<b>2.24 Nom kW Standard Motor &amp; Low Static Drive</b>											<b>2.24 Nom kW Standard Motor &amp; Drive</b>									
5440	-	-	-	-	-	-	-	-	718	0.72	754	0.82	789	0.93	822	1.03	856	1.14	887	1.25
6120	-	-	-	-	-	-	731	0.81	764	0.90	797	0.99	829	1.10	860	1.22	892	1.34	922	1.46
6800	-	-	715	0.81	747	0.90	782	1.01	814	1.11	844	1.21	874	1.32	903	1.44	932	1.56	960	1.69
7480	741	0.95	773	1.04	803	1.14	834	1.24	864	1.36	894	1.48	922	1.59	948	1.70	975	1.82	1001	1.95
8160	803	1.21	833	1.31	861	1.42	887	1.52	916	1.64	945	1.77	972	1.90	997	2.02	1022	2.14	1046	2.27
<b>2.24 Nom kW Standard Motor &amp; High Static Drive</b>											<b>2.24 Nom kW Standard Motor &amp; Drive</b>									
	275		300		325		350		375		400		425		450		475		500	
	RPM	kW	RPM	kW	RPM	kW	RPM	kW	RPM	kW	RPM	kW	RPM	kW	RPM	kW	RPM	kW	RPM	kW
5440	917	1.36	945	1.47	973	1.60	999	1.72	1024	1.84	1048	1.97	1072	2.10	1095	2.23	1117	2.37	1140	3.36
6120	951	1.57	979	1.69	1007	1.82	1033	1.94	1059	2.07	1082	2.20	1107	2.34	1130	2.49	1152	2.63	1173	3.71
6800	988	1.82	1015	1.95	1042	2.08	1068	2.21	1093	2.35	1117	2.48	1142	2.63	1164	2.76	1187	2.91	1209	4.11
7480	1028	2.09	1053	2.23	1078	2.38	1103	2.52	1128	2.66	1152	2.81	1176	2.95	1198	3.10	1221	3.25	-	-
8160	1071	2.41	1095	2.55	1119	2.70	1142	2.86	1166	3.02	1189	3.17	1212	3.33	-	-	-	-	-	-

Notes:  
 Data Includes Pressure Drop Due To Wet Coils And Filters.  
 2.24 kW - Fan Motor Heat (kW) = 1.138 x Fan kW + 0.139

Factory Supplied Motors, In Commercial Equipment, Are Definite Purpose Motors, Specifically Designed And Tested To Operate Reliably And Continuously At All Cataloged Conditions. Using The Full Horsepower Range Of Our Fan Motors As Shown In Our Tabular Data Will Not Result In Nuisance Tripping Or Premature Motor Failure. Our Product's Warranty Will Not Be Affected.

**Table PD-14a — Belt Drive Evaporator Fan Performance -TSC120AD - Downflow Configuration (IP)**

CFM	External Static Pressure (Inches of Water)																			
	.10		.20		.30		.40		.50		.60		.70		.80		.90		1.00	
	RPM	BHP	RPM	BHP	RPM	BHP	RPM	BHP	RPM	BHP	RPM	BHP	RPM	BHP	RPM	BHP	RPM	BHP	RPM	BHP
<b>3 HP Standard Motor &amp; Low Static Drive</b>									<b>3 HP Standard Motor &amp; Drive</b>											
3200	-	-	-	-	-	-	-	-	718	0.97	754	1.10	789	1.25	822	1.38	856	1.53	887	1.67
3600	-	-	-	-	-	-	731	1.08	764	1.20	797	1.33	829	1.48	860	1.63	892	1.79	922	1.95
4000	-	-	715	1.09	747	1.21	782	1.35	814	1.49	844	1.63	874	1.77	903	1.93	932	2.09	960	2.27
4400	741	1.27	773	1.40	803	1.53	834	1.67	864	1.82	894	1.98	922	2.13	948	2.28	975	2.44	1001	2.62
4800	803	1.62	833	1.76	861	1.90	887	2.04	916	2.20	945	2.38	972	2.55	997	2.71	1022	2.87	1046	3.04
<b>3 HP Standard Motor &amp; High Static Drive</b>									<b>3 HP Standard Motor &amp; Drive</b>											
	1.10		1.20		1.30		1.40		1.50		1.60		1.70		1.80		1.90		2.00	
	RPM	BHP	RPM	BHP	RPM	BHP	RPM	BHP	RPM	BHP	RPM	BHP	RPM	BHP	RPM	BHP	RPM	BHP	RPM	BHP
3200	917	1.82	945	1.97	973	2.14	999	2.30	1024	2.47	1048	2.65	1072	2.82	1095	3.00	1117	3.17	1140	3.36
3600	951	2.11	979	2.27	1007	2.43	1033	2.60	1059	2.78	1082	2.95	1107	3.14	1130	3.33	1152	3.52	1173	3.71
4000	988	2.44	1015	2.62	1042	2.79	1068	2.97	1093	3.15	1117	3.33	1142	3.52	1164	3.70	1187	3.91	1209	4.11
4400	1028	2.81	1053	3.00	1078	3.19	1103	3.38	1128	3.57	1152	3.77	1176	3.96	1198	4.15	1221	4.36	-	-
4800	1071	3.23	1095	3.42	1119	3.62	1142	3.83	1166	4.04	1189	4.25	1212	4.46	-	-	-	-	-	-

Notes:  
 Data Includes Pressure Drop Due To Wet Coils And Filters.  
 3 HP - Fan Motor Heat (MBH) = 2.900 x Fan BHP + 0.475

Factory Supplied Motors, In Commercial Equipment, Are Definite Purpose Motors, Specifically Designed And Tested To Operate Reliably And Continuously At All Cataloged Conditions. Using The Full Horsepower Range Of Our Fan Motors As Shown In Our Tabular Data Will Not Result In Nuisance Tripping Or Premature Motor Failure. Our Product's Warranty Will Not Be Affected.



# Performance Data

**Table PD-15 — Belt Drive Evaporator Fan Performance -TSC120AD - Horizontal Configuration (SI)**

m³/h	External Static Pressure (Pascals)																				
	25		50		75		100		125		150		175		200		225		250		
	RPM	kW	RPM	kW	RPM	kW	RPM	kW	RPM	kW	RPM	kW	RPM	kW	RPM	kW	RPM	kW	RPM	kW	
<b>2.24 Nom kW Standard Motor &amp; Low Static Drive</b>											<b>2.24 Nom kW Standard Motor &amp; Drive</b>										
5440	-	-	691	0.67	730	0.75	771	0.84	807	0.94	844	1.04	886	1.16	926	1.28	965	1.41	1000	1.53	
6120	729	0.84	761	0.91	792	0.99	829	1.08	865	1.19	898	1.30	930	1.41	965	1.53	1002	1.67	1038	1.81	
6800	802	1.13	833	1.22	860	1.29	890	1.38	923	1.50	956	1.62	986	1.73	1015	1.85	1044	1.98	1077	2.12	
7480	876	1.49	905	1.58	931	1.67	955	1.75	983	1.86	1014	1.99	1045	2.12	1072	2.25	1098	2.37	1125	2.51	
8160	950	1.91	977	2.02	1002	2.11	1025	2.20	1048	2.30	1074	2.42	1102	2.56	1131	2.71	1156	2.84	1181	2.98	
<b>2.24 Nom kW Standard Motor &amp; High Static Drive</b>																					

m³/h	External Static Pressure (Pascals)																				
	275		300		325		350		375		400		425		450		475		500		
	RPM	kW	RPM	kW	RPM	kW	RPM	kW	RPM	kW	RPM	kW	RPM	kW	RPM	kW	RPM	kW	RPM	kW	
<b>2.24 Nom kW Std Mtr &amp; Drive</b>											<b>2.24 Nom kW Standard Motor &amp; High Static Drive</b>										
5440	1029	1.64	1057	1.75	1084	1.86	1108	1.96	1132	2.06	1155	2.17	1177	2.27	1198	2.37	1219	2.48	1239	3.46	
6120	1072	1.95	1106	2.10	1134	2.22	1160	2.35	1185	2.47	1209	2.59	1231	2.70	1252	2.82	1274	2.94	1295	4.10	
6800	1111	2.28	1143	2.43	1174	2.58	1204	2.74	1232	2.90	1260	3.05	1283	3.18	1306	3.32	-	-	-	-	
7480	1152	2.65	1182	2.81	1211	2.97	1241	3.14	1270	3.31	-	-	-	-	-	-	-	-	-	-	
8160	1205	3.12	1229	3.27	-	-	-	-	-	-	-	-	-	-	-	-	-	-	-	-	

Notes: Factory Supplied Motors, In Commercial Equipment, Are Definite Purpose Motors, Specifically Designed And Tested To Operate Reliably And Continuously At All Cataloged Conditions. Using The Full Horsepower Range Of Our Fan Motors As Shown In Our Tabular Data Will Not Result In Nuisance Tripping Or Premature Motor Failure. Our Product's Warranty Will Not Be Affected.

Data Includes Pressure Drop Due To Wet Coils And Filters.  
 2.24 kW - Fan Motor Heat (kW) = 1.138 x Fan kW + 0.139

**Table PD-15a — Belt Drive Evaporator Fan Performance -TSC120AD - Horizontal Configuration (IP)**

CFM	External Static Pressure (Inches of Water)																				
	.10		.20		.30		.40		.50		.60		.70		.80		.90		1.00		
	RPM	BHP	RPM	BHP	RPM	BHP	RPM	BHP	RPM	BHP	RPM	BHP	RPM	BHP	RPM	BHP	RPM	BHP	RPM	BHP	
<b>3 HP Standard Motor &amp; Low Static Drive</b>											<b>3 HP Standard Motor &amp; Drive</b>										
3200	-	-	691	0.89	730	1.00	771	1.13	807	1.26	844	1.39	886	1.55	926	1.72	965	1.89	1000	2.06	
3600	729	1.13	761	1.22	792	1.32	829	1.45	865	1.60	898	1.74	930	1.89	965	2.06	1002	2.24	1038	2.43	
4000	802	1.52	833	1.63	860	1.73	890	1.86	923	2.01	956	2.17	986	2.32	1015	2.48	1044	2.65	1077	2.85	
4400	876	1.99	905	2.12	931	2.24	955	2.35	983	2.49	1014	2.66	1045	2.84	1072	3.01	1098	3.18	1125	3.36	
4800	950	2.56	977	2.70	1002	2.84	1025	2.96	1048	3.08	1074	3.24	1102	3.43	1131	3.63	1156	3.81	1181	4.00	
<b>3 HP Standard Motor &amp; High Static Drive</b>																					

CFM	External Static Pressure (Inches of Water)																				
	1.10		1.20		1.30		1.40		1.50		1.60		1.70		1.80		1.90		2.00		
	RPM	BHP	RPM	BHP	RPM	BHP	RPM	BHP	RPM	BHP	RPM	BHP	RPM	BHP	RPM	BHP	RPM	BHP	RPM	BHP	
<b>3 HP Std Mtr &amp; Drive</b>											<b>3 HP Standard Motor &amp; High Static Drive</b>										
3200	1029	2.20	1057	2.35	1084	2.49	1108	2.63	1132	2.77	1155	2.91	1177	3.05	1198	3.18	1219	3.32	1239	3.46	
3600	1072	2.62	1106	2.81	1134	2.98	1160	3.15	1185	3.31	1209	3.47	1231	3.63	1252	3.78	1274	3.94	1295	4.10	
4000	1111	3.05	1143	3.26	1174	3.47	1204	3.68	1232	3.88	1260	4.09	1283	4.27	1306	4.46	-	-	-	-	
4400	1152	3.55	1182	3.76	1211	3.99	1241	4.21	1270	4.44	-	-	-	-	-	-	-	-	-	-	
4800	1205	4.19	1229	4.39	-	-	-	-	-	-	-	-	-	-	-	-	-	-	-	-	

Notes: Factory Supplied Motors, In Commercial Equipment, Are Definite Purpose Motors, Specifically Designed And Tested To Operate Reliably And Continuously At All Cataloged Conditions. Using The Full Horsepower Range Of Our Fan Motors As Shown In Our Tabular Data Will Not Result In Nuisance Tripping Or Premature Motor Failure. Our Product's Warranty Will Not Be Affected.

Data Includes Pressure Drop Due To Wet Coils And Filters.  
 3 HP - Fan Motor Heat (MBH) = 2.900 x Fan BHP + 0.475

# Performance Data

**Table PD-16 — Standard Motor & Sheave/Fan Speed (RPM)**

Unit	6 Turns	5 Turns	4 Turns	3 Turns	2 Turns	1 Turns	
Model No.	Open	Open	Open	Open	Open	Open	Closed
TSC060AD	N/A	898	967	1036	1105	1174	1243
TSC072AD	N/A	698	751	806	859	913	967
TSC090AD	N/A	752	806	860	914	968	1020
TSC102AD	N/A	688	737	786	835	885	934
TSC120AD	N/A	782	838	894	950	1006	1062

Factory set at 3 turns open

**Table PD-17 — Standard Motor & Low Static Drive Accessory Sheave/Fan Speed (RPM)**

Unit	6 Turns	5 Turns	4 Turns	3 Turns	2 Turns	1 Turns	
Model No.	Open	Open	Open	Open	Open	Open	Closed
TSC060AD	N/A	691	760	829	898	967	1036
TSC072AD	N/A	537	590	644	698	752	806
TSC090AD	N/A	671	714	757	800	843	886
TSC102AD	N/A	629	664	701	737	773	811
TSC120AD	N/A	717	754	799	844	885	922

Factory set at 3 turns open

**Table PD-18 — Standard Motor & High Static Drive Accessory Sheave/Fan Speed (RPM)**

Unit	6 Turns	5 Turns	4 Turns	3 Turns	2 Turns	1 Turns	
Model No.	Open	Open	Open	Open	Open	Open	Closed
TSC060AD	N/A	1243	1311	1379	1450	1515	1588
TSC072AD	N/A	967	1021	1075	1128	1183	1235
TSC090AD	1020	1073	1127	1181	1235	1289	N/A
TSC102AD	936	981	1032	1083	1134	1182	N/A
TSC120AD	1062	1118	1174	1229	1285	1341	N/A

Factory set at 3 turns open

**Table PD-19 — Oversized Motor & Drive Sheave/Fan Speed (RPM)**

Unit	6 Turns	5 Turns	4 Turns	3 Turns	2 Turns	1 Turns	
Model No.	Open	Open	Open	Open	Open	Open	Closed
TSC072AD	N/A	967	1021	1075	1128	1183	1235
TSC090AD	1112	1182	1252	1322	1392	1460	N/A
TSC102AD	N/A	971	1041	1111	1181	1251	1321
TSC120AD	N/A	N/A	N/A	N/A	N/A	N/A	N/A

Factory set at 3 turns open

**Table PD-20 — Sound Power Level - dB (ref. 10<sup>-12</sup> Watts)**

Unit	Octave Center Frequency							Overall	
Model No.	63	125	250	500	1000	2000	4000	8000	dBA
TSC060AD	84	91	79	77	74	71	68	63	80
TSC072AD	83	90	86	82	79	75	70	63	85
TSC090AD	83	90	86	83	80	75	71	64	85
TSC102AD	83	89	84	81	77	72	69	62	83
TSC120AD	83	86	80	77	73	69	66	60	79

Note:

Tests follow ARI 270-95



# Performance Data

**Table PD-21 — Static Pressure Drops Through Accessories - (Pascals)**

Unit Model No.	Airflow (m <sup>3</sup> /h)	Standard Filters <sup>1</sup>	Pleated Filters (50 mm)	Economizer OA/RA Dampers <sup>2</sup>				Electric Heater Accessory (kW) <sup>3</sup>		
				100% OA Downflow	100% RA	100% OA Horizontal	100% RA	9	13-27	40
TSC060AD	2720	25	37	30	11	30	4	11	13	-
	3400	37	55	46	17	46	6	17	21	-
	4080	55	72	64	26	64	9	25	30	-
TSC072AD	3260	10	17	25	2	15	5	-	5	-
	4080	15	22	27	5	20	5	-	8	-
	4890	22	30	33	10	25	10	-	13	-
TSC090AD	4080	15	22	27	5	20	5	-	8	-
	5100	25	32	35	12	30	12	-	16	-
	6120	35	45	52	17	62	20	-	25	-
TSC102AD	4620	12	20	31	7	22	10	-	6	-
	5780	20	27	47	15	45	15	-	10	-
	6930	30	40	75	17	77	22	-	15	-
TSC120AD	5440	17	25	42	12	35	12	-	9	10
	6800	27	37	65	17	75	20	-	14	17
	8160	40	50	85	22	87	25	-	20	26

**Notes:**

1. Tested with standard filters. The TSC060AD has 25 mm (1 inch) standard filters. The TSC072AD - 120AD has 50 mm (2 inch) standard filters. The difference in pressure drop should be considered when utilizing optional 50 mm (2 inch) pleated filters.
2. OA = Outside Air and RA = Return Air
3. Nominal kW ratings at 415 V

**Table PD-21a — Static Pressure Drops Through Accessories - (Inches of Water Column)**

Unit Model No.	Airflow (CFM)	Standard Filters <sup>1</sup>	Pleated Filters (2 inch)	Economizer OA/RA Dampers <sup>2</sup>				Electric Heater Accessory (kW) <sup>3</sup>		
				100% OA Downflow	100% RA	100% OA Horizontal	100% RA	9	13-27	40
TSC060AD	1600	0.10	0.15	0.12	0.04	0.12	0.01	0.045	0.053	-
	2000	0.15	0.22	0.18	0.07	0.18	0.02	0.070	0.083	-
	2400	0.22	0.29	0.26	0.10	0.26	0.04	0.100	0.120	-
TSC072AD	1920	0.04	0.07	0.10	0.01	0.06	0.02	-	0.021	-
	2400	0.06	0.09	0.11	0.02	0.08	0.02	-	0.034	-
	2880	0.09	0.12	0.13	0.04	0.10	0.04	-	0.052	-
TSC090AD	2400	0.06	0.09	0.11	0.02	0.08	0.02	-	0.034	-
	3000	0.10	0.13	0.14	0.05	0.12	0.05	-	0.063	-
	3600	0.14	0.18	0.21	0.07	0.25	0.08	-	0.102	-
TSC102AD	2720	0.05	0.08	0.12	0.03	0.09	0.04	-	0.026	-
	3400	0.08	0.11	0.19	0.06	0.18	0.06	-	0.041	-
	4080	0.12	0.16	0.30	0.07	0.31	0.09	-	0.059	-
TSC120AD	3200	0.07	0.10	0.17	0.05	0.14	0.05	-	0.036	0.042
	4000	0.11	0.15	0.26	0.07	0.30	0.08	-	0.056	0.070
	4800	0.16	0.20	0.34	0.09	0.35	0.10	-	0.081	0.106

**Notes:**

1. Tested with standard filters. The TSC060AD has 25 mm (1 inch) standard filters. The TSC072AD - 120AD has 50 mm (2 inch) standard filters. The difference in pressure drop should be considered when utilizing optional 50 mm (2 inch) pleated filters.
2. OA = Outside Air and RA = Return Air
3. Nominal kW ratings at 415 V

**Table PD-22 - Electric Heater Voltage Correction Factors (Apply to Auxiliary Electric Heat Capacity)**

Nominal Voltage	Distribution Voltage	Capacity Multiplier
415	380	0.84
	400	0.93
	415	1.00



# Performance Data

**Table PD-23 — Auxiliary Electric Heat Capacity (SI)**

Unit Model No.	Unit Voltage	Total <sup>2</sup>		Stage 1	Stage 2
		KW	No. Stages	KW	KW
TSC060AD	380-415/50/3	7.5 / 9.0	2	3.75 / 4.5	3.75 / 4.5
		10.9 / 13.0	2	5.45 / 6.5	5.45 / 6.5
		14.4 / 17.2	2	8.95 / 10.7	5.45 / 6.5
TSC072AD	380-415/50/3	11.3 / 13.5	1	11.3 / 13.5	—
		16.9 / 20.2	2	11.3 / 13.5	5.6 / 6.7
		22.6 / 26.9	2	11.3 / 13.5	11.3 / 13.5
TSC090AD	380-415/50/3	11.3 / 13.5	1	11.3 / 13.5	—
		16.9 / 20.2	2	11.3 / 13.5	5.6 / 6.7
		22.6 / 26.9	2	11.3 / 13.5	11.3 / 13.5
TSC102AD	380-415/50/3	16.9 / 20.2	2	11.3 / 13.6	5.6 / 6.7
		22.6 / 26.9	2	11.3 / 13.7	11.3 / 13.5
		16.9 / 20.2	2	11.3 / 13.8	5.6 / 6.7
TSC120AD	380-415/50/3	22.6 / 26.9	2	11.3 / 13.9	11.3 / 13.5
		33.9 / 40.4	2	11.3 / 13.10	22.5 / 26.9

Notes:

1. Does not include indoor fan power or heat
2. Heaters are rated at 380V / 415V. For other than rated voltage, CAP=(Voltage/Rated Voltage)<sup>2</sup> x Rated Cap.

**Table PD-23A — Auxiliary Electric Heat Capacity (IP)**

Unit Model No.	Unit Voltage	Total <sup>2</sup>		Stage 1	Stage 2
		MBH	No. Stages	MBH	MBH
TSC060AD	380-415/50/3	26 / 31	2	13 / 16	13 / 16
		38 / 45	2	19 / 23	19 / 23
		50 / 59	2	31 / 37	19 / 23
TSC072AD	380-415/50/3	39 / 47	1	39 / 47	—
		58 / 69	2	39 / 47	20 / 23
		78 / 92	2	39 / 47	39 / 47
TSC090AD	380-415/50/3	39 / 47	1	39 / 47	—
		58 / 69	2	39 / 47	20 / 23
		78 / 92	2	39 / 47	39 / 47
TSC102AD	380-415/50/3	58 / 69	2	39 / 47	20 / 23
		78 / 92	2	39 / 47	39 / 47
		58 / 69	2	39 / 47	20 / 23
TSC120AD	380-415/50/3	78 / 92	2	39 / 47	39 / 47
		116 / 138	2	39 / 47	77 / 92

Notes:

1. Does not include indoor fan power or heat
2. Heaters are rated at 380 / 415V. For other than rated voltage, CAP=(Voltage/Rated Voltage)<sup>2</sup> x Rated Cap.



# Performance Data

**Table PD-24 — Air Temperature Rise Across Electric Heaters (Degrees C)**

kW 380V / 415V	Voltage	Stages	3400 m <sup>3</sup> /h	4100 m <sup>3</sup> /h	5100 m <sup>3</sup> /h	5800 m <sup>3</sup> /h	6800 m <sup>3</sup> /h
			TSC060AD	TSC072AD	TSC090AD	TSC102AD	TSC120AD
07.5 / 09.0	380-415/50/3	2	6.6 / 7.9	—	—	—	—
10.9 / 13.0	380-415/50/3	2	9.6 / 11.4	—	—	—	—
11.3 / 13.5	380-415/50/3	1	—	8.3 / 9.9	6.6 / 7.9	—	—
14.4 / 17.2	380-415/50/3	2	12.6 / 15.1	—	—	—	—
16.9 / 20.2	380-415/50/3	2	—	12.4 / 14.8	9.9 / 11.8	8.7 / 10.4	7.4 / 8.9
22.6 / 26.9	380-415/50/3	2	—	16.5 / 19.7	13.2 / 15.7	11.7 / 13.9	9.9 / 11.8
33.8 / 40.4	380-415/50/3	2	—	—	—	—	14.8 / 17.7

Note:  
 For minimum design airflow, see performance table for each unit.  
 To calculate temp rise at different airflow, use following formula:  
 Temp. Rise (C°) across Elect Htr = (kW x 2985)/(m<sup>3</sup>/h)

**Table PD-24A — Air Temperature Rise Across Electric Heaters (Degrees F)**

kW 380V / 415V	Voltage	Stages	2000 CFM	2400 CFM	3000 CFM	3400 CFM	4000 CFM
			TSC060AD	TSC072AD	TSC090AD	TSC102AD	TSC120AD
07.5 / 09.0	380-415/50/3	2	11.9 / 14.2	—	—	—	—
10.9 / 13.0	380-415/50/3	2	17.2 / 20.5	—	—	—	—
11.3 / 13.5	380-415/50/3	1	—	14.9 / 17.8	11.9 / 14.2	—	—
14.4 / 17.2	380-415/50/3	2	22.8 / 27.2	—	—	—	—
16.9 / 20.2	380-415/50/3	2	—	22.3 / 26.6	17.8 / 21.3	15.7 / 18.8	13.4 / 16.0
22.6 / 26.9	380-415/50/3	2	—	29.8 / 35.4	23.8 / 28.3	21.0 / 25.0	17.9 / 21.3
33.8 / 40.4	380-415/50/3	2	—	—	—	—	26.7 / 31.9

Note:  
 For minimum design airflow, see performance table for each unit.  
 To calculate temp rise at different airflow, use following formula:  
 Temp. Rise (F°) across Elect Htr = (kW x 3414)/(1.08 x CFM)



# Zone Controls

## Zone Sensors

**Zone Sensors** are the building occupant's comfort control devices for Precedent™ units with the ReliaTel control. The zone sensor offering operates with the ReliaTel microprocessor

**Manual Changeover** — Heat, Cool or Off System Switch. Fan Auto or Off Switch. One temperature setpoint lever.

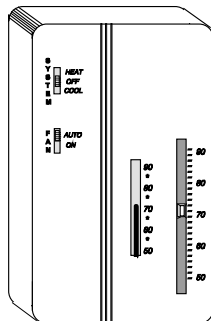

**Manual/Automatic Changeover** — Auto, Heat, Cool or Off System Switch. Fan Auto or Off Switch. Two temperature setpoint levers. Optional Status Indication LED lights, System On, Heat, Cool, or Service.

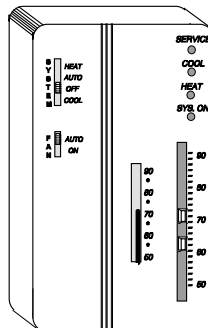

**Remote Sensor** — Sensor(s) available for all zone sensors to provide remote sensing capabilities.

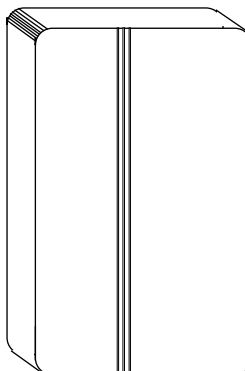

**Non-programmable manual auto changeover with digital LCD Display** — Auto, heat, cool or off mode selection button. Auto or off fan bottom. Status indication LCD indicators — System on, heat, cool, or service.

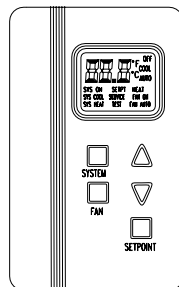

**Programmable Night Setback** — Auto or manual changeover with seven-day programming. Keyboard selection of Heat, Cool, Fan, Auto, or On. All programmable sensors have

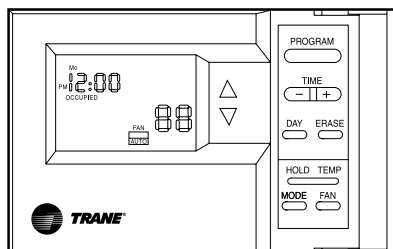

System On, Heat, Cool, Service LED/ indicators as standard. Night Setback Sensors have one (1) Occupied, one (1) Unoccupied, and two (2) Override programs per day.

**Integrated Comfort™ System** — Sensor(s) available with optional temperature adjustment and override buttons to provide central control through a Trane Integrated Comfort™ system.

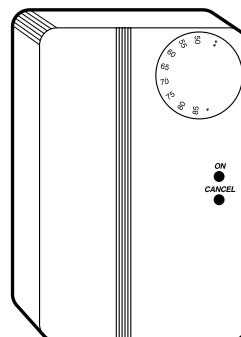

## Conventional Thermostats

**Conventional Thermostats** are the building occupant's comfort control devices when a generic thermostat is desired.

**Manual Changeover** — One Heat, One Cool Thermostat. Heat, Cool or Off System Switch. Fan Auto or On Switch. Set Point Dial. Adjustable Heat Anticipator.

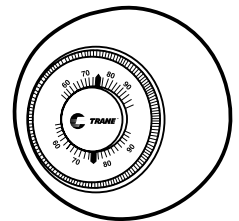

**Automatic Changeover** — One Heat, Two Cool Thermostat. Off, Auto System Switch. Auto/On Fan Switch.

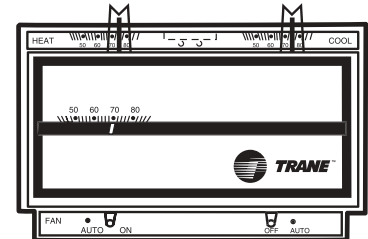

**Programmable Electronic Night Setback Thermostat** — Heating setback and cooling setup with 7-day, programming capability. Available in two-stage heating/cooling or one-stage heating/cooling versions with automatic changeover.

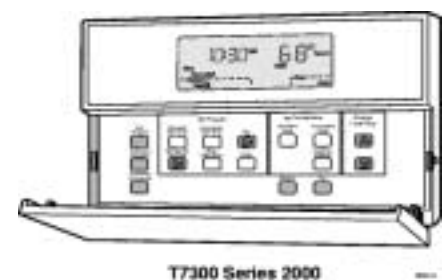



# Electrical Data

**Table ED-1 — Unit Wiring**

Unit Model No.	Unit Operating Voltage Range	Standard Indoor Fan Motor		Oversized Indoor Fan Motor	
		Minimum Circuit Ampacity	Maximum Fuse Size Or Maximum Circuit Breaker <sup>1</sup>	Minimum Circuit Ampacity	Maximum Fuse Size Or Maximum Circuit Breaker <sup>1</sup>
TSC060AD	342-456	17.7	25	17.7	25
TSC072AD	342-456	23.2	35	24.2	35
TSC090AD	342-456	24.8	35	26.5	35
TSC102AD	342-456	26.8	35	28.5	35
TSC120AD	342-456	31.2	40	31.2	40

Notes:

1. All units to be installed under local codes

**Table ED-2 — Unit Wiring With Electric Heat Single Point Connection — 380-415 Volts**

Unit Model No.	Heater Model No.	Heater <sup>2</sup>		Control Stages	Standard Indoor Fan Motor		Oversized Indoor Fan Motor	
		kW Rating	MBH		Minimum Circuit Ampacity	Maximum Fuse Size Or Maximum Circuit Breaker <sup>1</sup>	Minimum Circuit Ampacity	Maximum Fuse Size Or Maximum Circuit Breaker <sup>1</sup>
TSC060AD	BAYHTRR412A	7.5 / 9.0	26 / 31	2	19.8 / 21.0	25 / 25	19.8 / 21.0	25 / 25
	BAYHTRR418A	10.9 / 13.0	38 / 45	2	26.1 / 28.0	30 / 30	26.1 / 28.0	30 / 30
	BAYHTRR423A	14.4 / 17.2	50 / 59	2	32.8 / 35.3	35 / 40	32.8 / 35.3	35 / 40
TSC072AD	BAYHTRS418A	11.3 / 13.5	39 / 47	1	26.9 / 28.9	35 / 35	28.1 / 30.1	35 / 35
	BAYHTRS427A	16.9 / 20.2	58 / 69	2	37.5 / 40.5	40 / 45	38.8 / 41.8	40 / 45
	BAYHTRS436A	22.6 / 26.9	78 / 92	2	48.3 / 52.1	50 / 60	49.5 / 53.4	50 / 60
TSC090AD	BAYHTRS418A	11.3 / 13.5	39 / 47	1	28.1 / 30.1	35 / 35	30.3 / 32.3	35 / 35
	BAYHTRS427A	16.9 / 20.2	58 / 69	2	38.8 / 41.8	40 / 45	40.9 / 43.9	45 / 45
	BAYHTRS436A	22.6 / 26.9	78 / 92	2	49.5 / 53.4	50 / 60	51.6 / 55.5	60 / 60
TSC102AD	BAYHTRT427A	16.9 / 20.2	58 / 69	2	38.8 / 41.8	40 / 45	40.9 / 43.9	45 / 45
	BAYHTRT436A	22.6 / 26.9	78 / 92	2	49.5 / 53.4	50 / 60	51.6 / 55.5	60 / 60
TSC120AD	BAYHTRT427A	16.9 / 20.2	58 / 69	2	40.9 / 43.9	45 / 45	40.9 / 43.9	45 / 45
	BAYHTRT436A	22.6 / 26.9	78 / 92	2	51.6 / 55.5	60 / 60	51.6 / 55.5	60 / 60
	BAYHTRT454A	33.8 / 40.4	116 / 138	2	73.1 / 79.0	80 / 80	73.1 / 79.0	80 / 80

Notes:

1. All units to be installed under local codes
2. kW and MBH shown for 380V / 415V

**Table ED-3 — Electrical Characteristics - Evaporator Fan Motor - 50 Hz**

Unit Model No.	Standard Evaporator Fan Motor						Oversized Evaporator Fan Motor					
	No.	Volts	Phase	HP	Amps		No.	Volts	Phase	HP	Amps	
					FLA	LRA					FLA	LRA
TSC060AD	1	380-415	3	1.5	4.3	25.3	-	-	-	-	-	-
TSC072AD	1	380-415	3	1.5	4.3	25.3	1	380-415	3	2.0	5.3	36.4
TSC090AD	1	380-415	3	2.0	5.3	36.4	1	380-415	3	3.0	7.0	57.0
TSC102AD	1	380-415	3	2.0	5.3	36.4	1	380-415	3	3.0	7.0	57.0
TSC120AD	1	380-415	3	3.0	7.0	57.0	-	-	-	-	-	-

**Table ED-4 — Electrical Characteristics - Compressor Motor and Condenser Motor - 50 Hz**

Unit Model No.	Compressor Motor							Condenser Fan Motor				
	No.	Volts	Phase	HP <sup>1</sup>	RPM	Amps		No.	Phase	HP	Amps	
						RLA <sup>1</sup>	LRA <sup>1</sup>				FLA	LRA
TSC060AD	1	380-415	3	5.7	2875	9.5	74.00	1	1	0.40	1.9	2.8
TSC072AD	1	380-415	3	7.5	2875	12.7	95.00	1	1	0.75	2.8	7.1
TSC090AD	1	380-415	3	8.3	2875	13.20	100.00	1	1	0.75	2.8	7.1
TSC102AD	2	380-415	3	6.0/3.8	2875	9.3/6.9	74.0/48.0	1	1	0.75	2.8	7.1
TSC120AD	2	380-415	3	6.0/4.8	2875	9.9/8.5	74.0/61.8	1	1	0.75	2.8	7.1

Note:

1. Comp1/Comp2

# Jobsite Connections

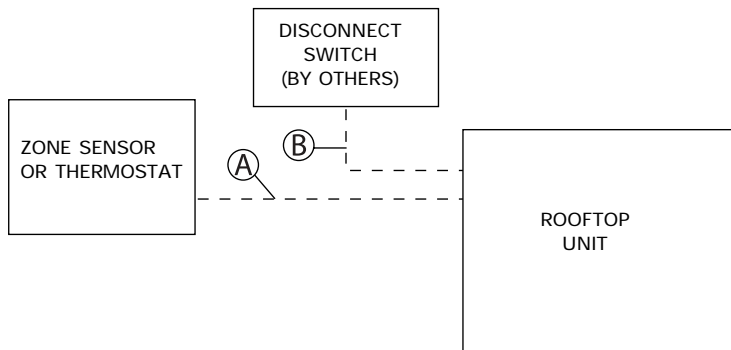

## Zone Sensors — Typical Number Of Wires

A — Manual Changeover . . . . .	4
Manual/Auto Changeover . . . . .	5
Manual/Auto Changeover with Status Indication LED's . . . . .	10
Programmable Night Setback with Status Indication LED's . . . . .	7

## Thermostats — Typical Number of Wires

- A — 3 wires, 24-volts, Cooling Only
- 4 wires, 24-volts, with Electric Heat
- B — 3 Power Wires + 1 Ground Wire (three phase)
- 2 Power Wires + 1 Ground Wire (single phase)

For specific wiring information, see the installation instructions.

All wiring except power wires is low voltage.

All customer supplied wiring to be copper and must conform to NEC or CEC and local electrical codes. Wiring shown dotted is to be furnished and installed by the customer.

# Dimensional Data

## TSC060

All dimensions are in inches/millimeters.

### TSC060

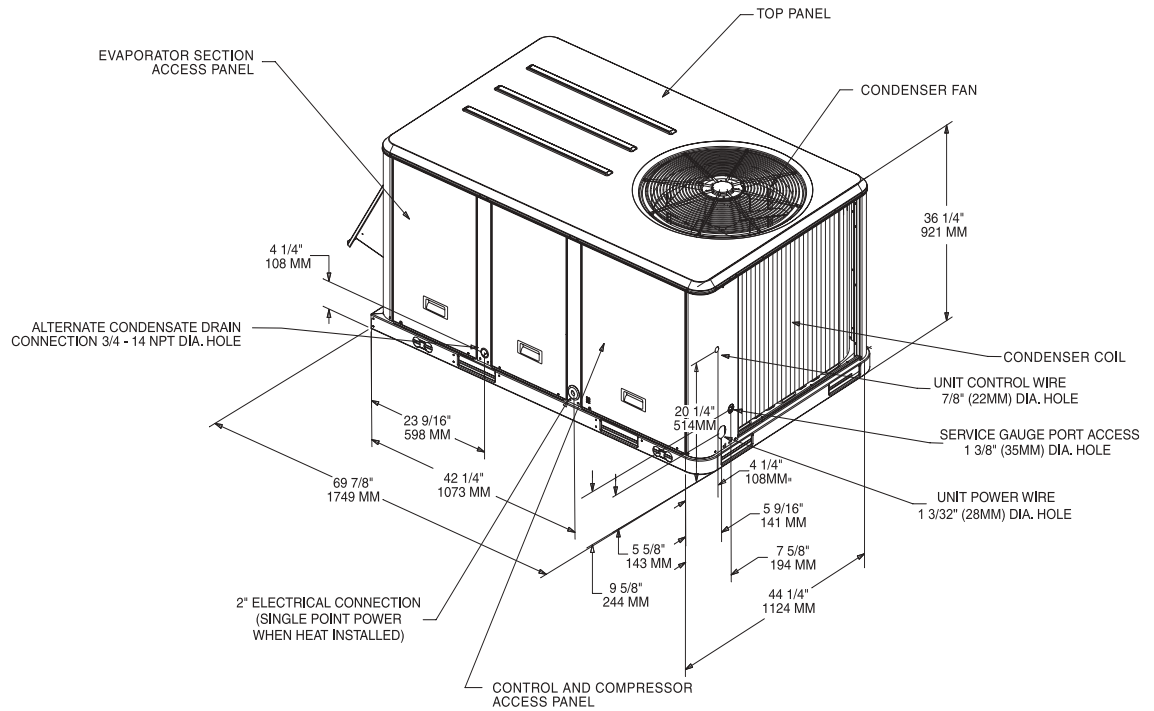

# Dimensional Data

## TSC060

All dimensions are in inches/millimeters.

*TSC060 — Downflow Airflow Supply/Return*

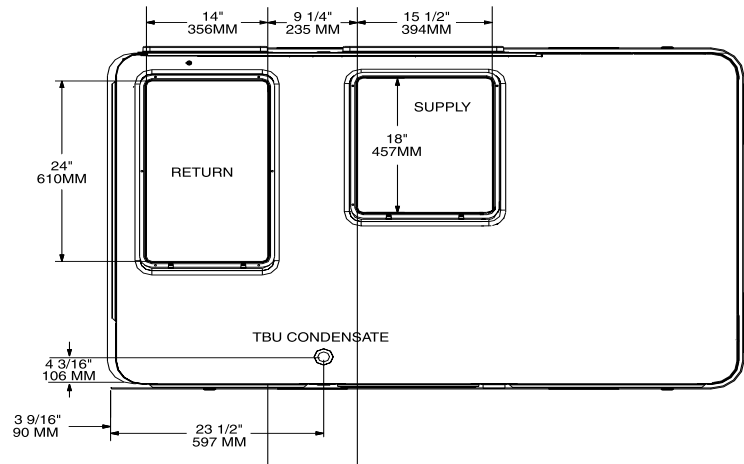

*TSC060 — Horizontal Airflow Supply/Return*

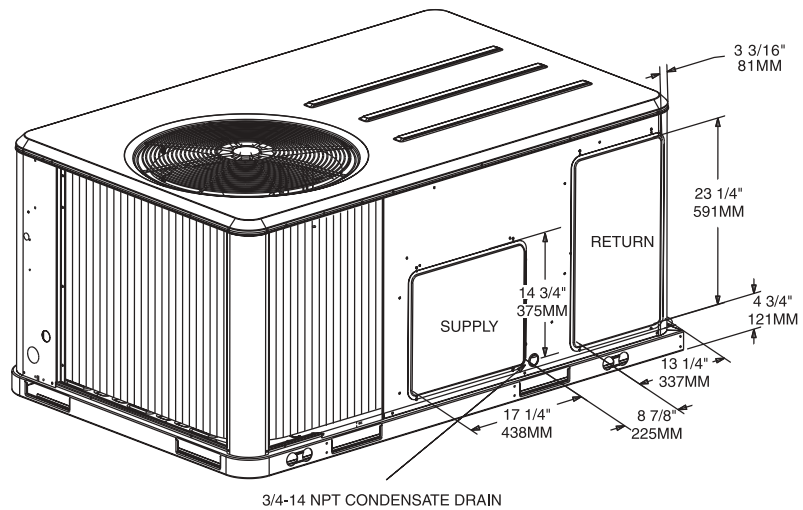

*TSC060 — Unit Clearance and Roof Opening*

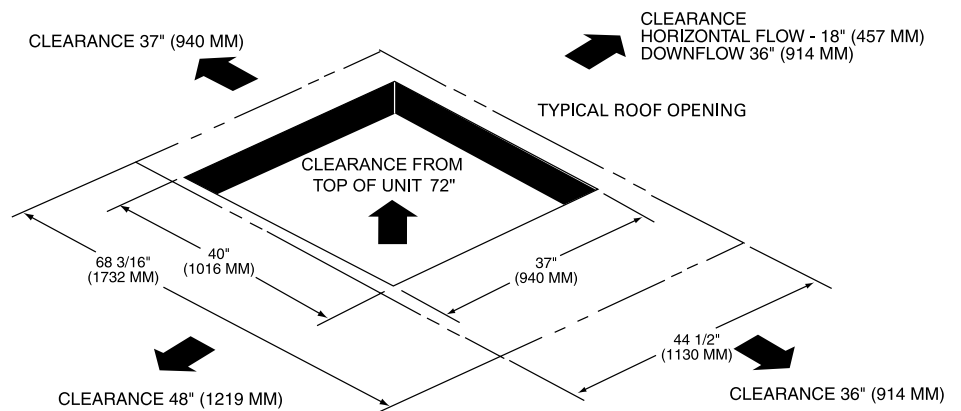

# Dimensional Data

## TSC060

All dimensions are in inches/millimeters.

**TSC060 — Roof Curb**

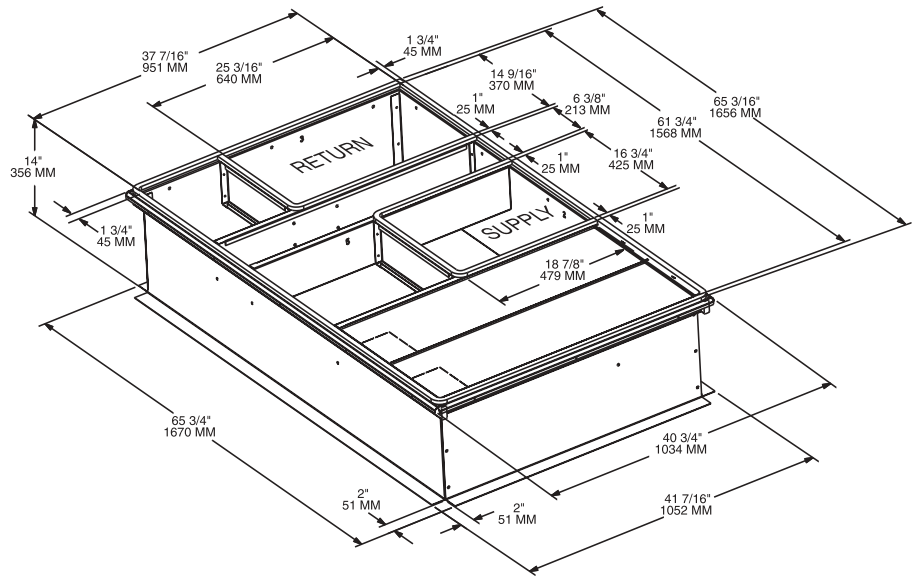

**TSC060 — Downflow Duct Connections — Field Fabricated**

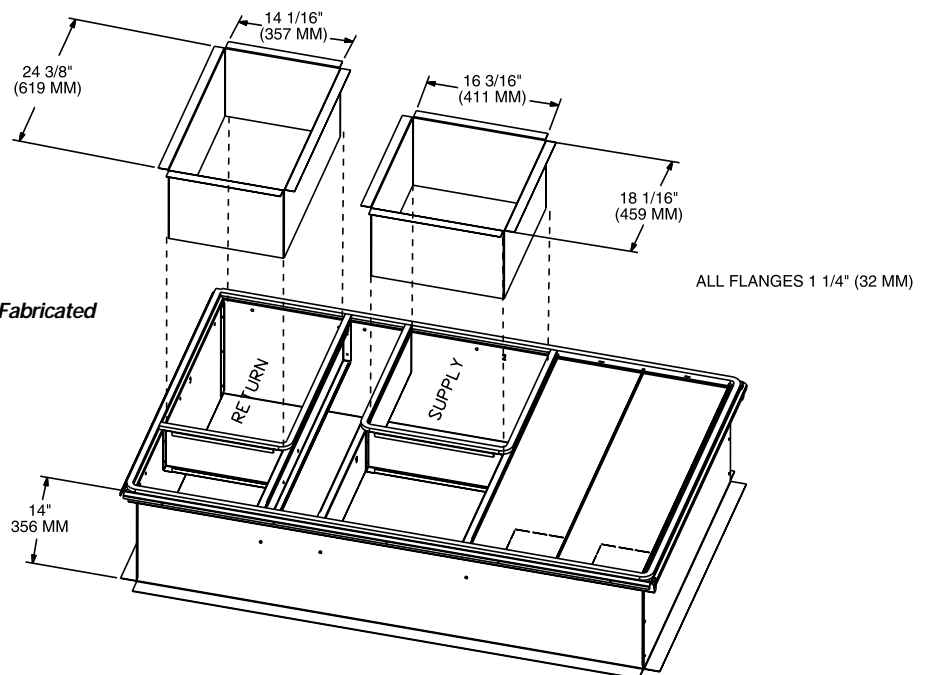

# Dimensional Data

## TSC072-120

All dimensions are in inches/millimeters.

**TSC072-090**

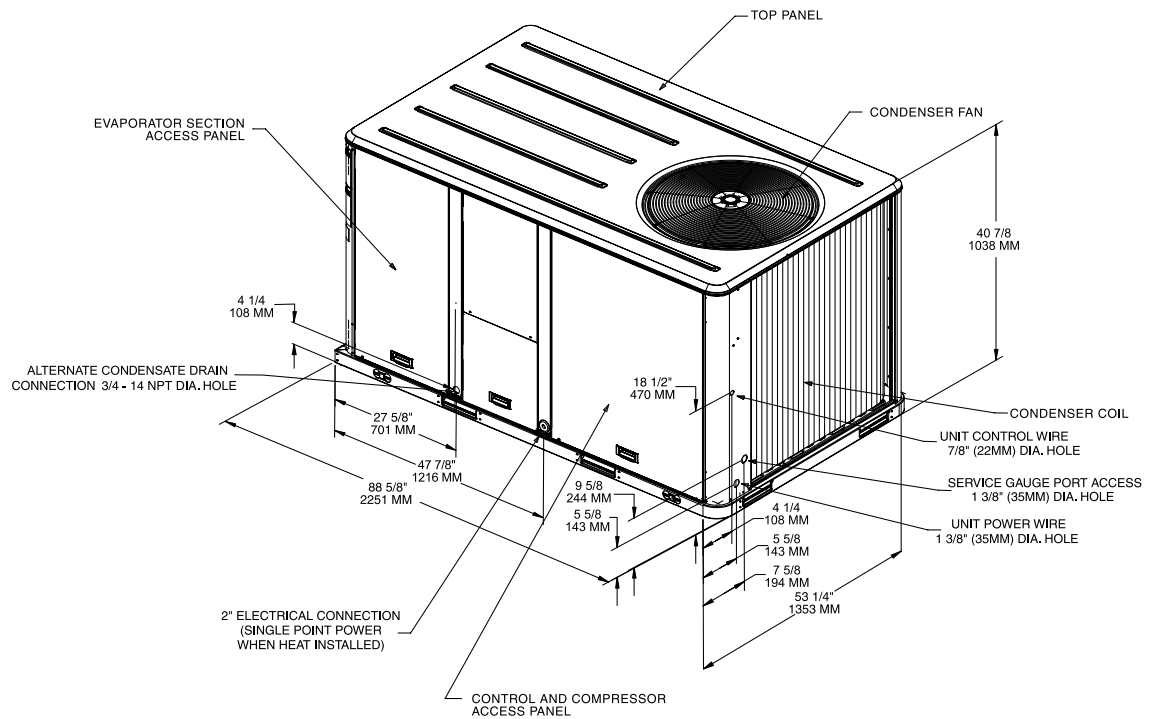

**TSC102-120**

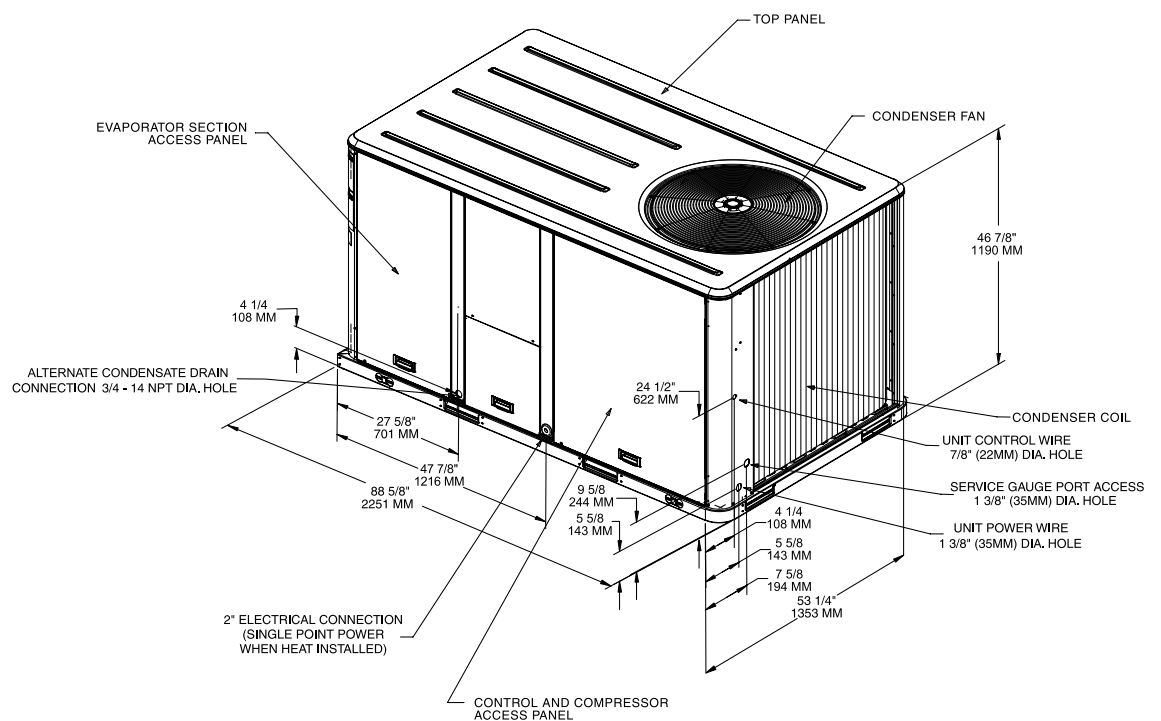



# Dimensional Data

## TSC072-120

All dimensions are in inches/millimeters.

**TSC072-120 — Downflow Airflow Supply and Return**

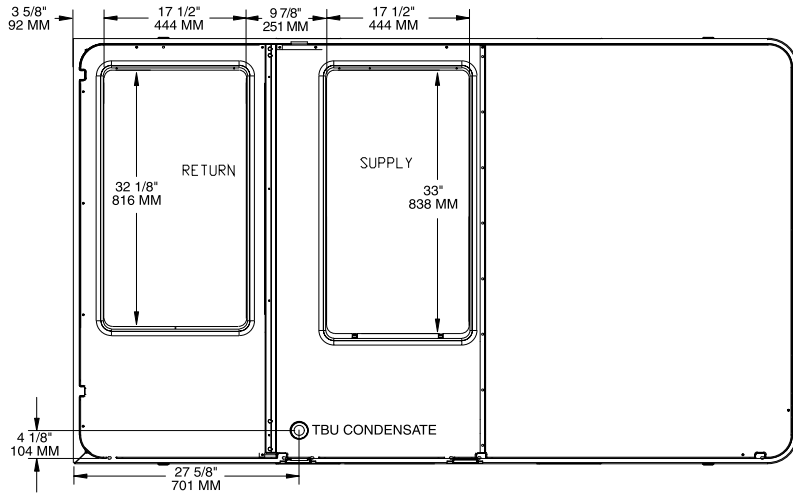

**TSC072-120 — Horizontal Airflow Supply and Return**

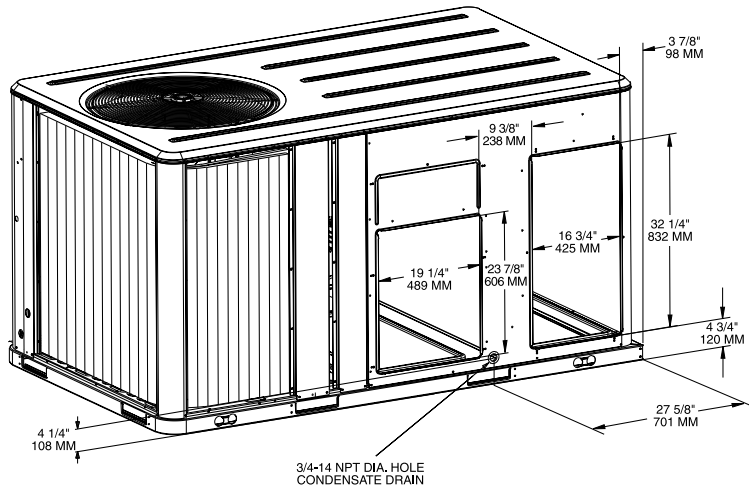

**TSC072-120 — Unit Clearance and Roof Opening**

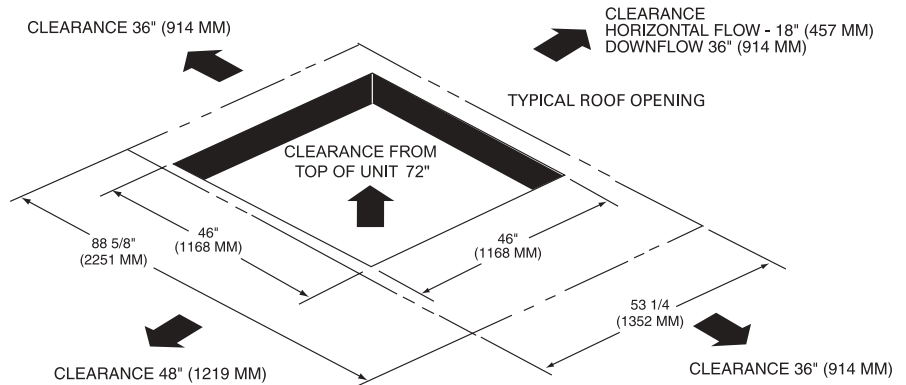



# Dimensional Data

## TSC072-120

All dimensions are in inches/millimeters.

**TSC072-120 — Roof Curb**

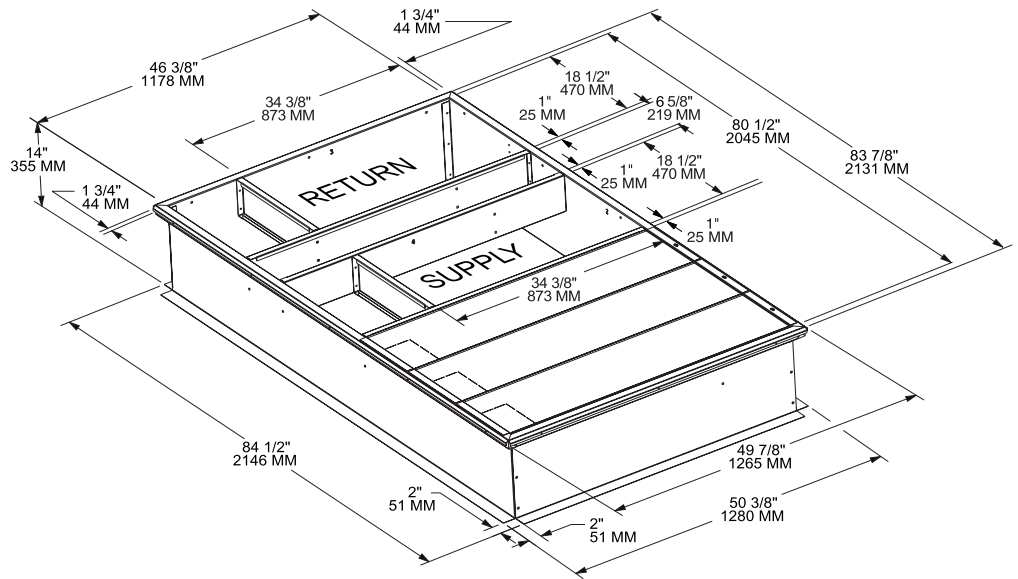

**TSC072-120 — Downflow Duct Connections — Field Fabricated**

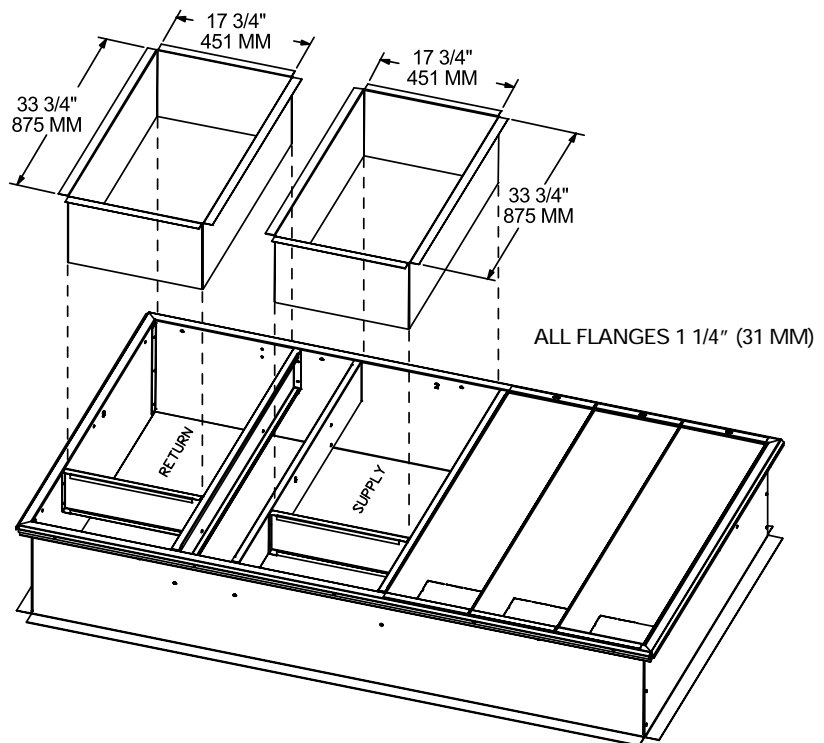



# Dimensional Data

# TSC060 Options/Accessories

All dimensions are in inches/millimeters.

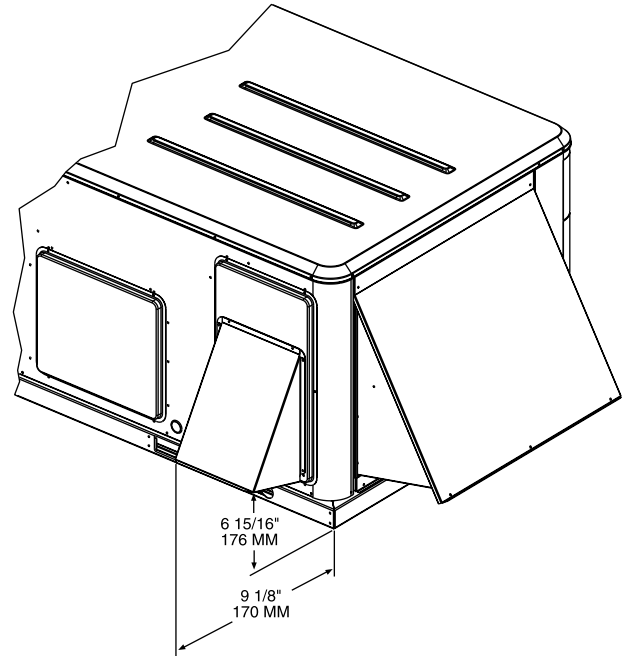
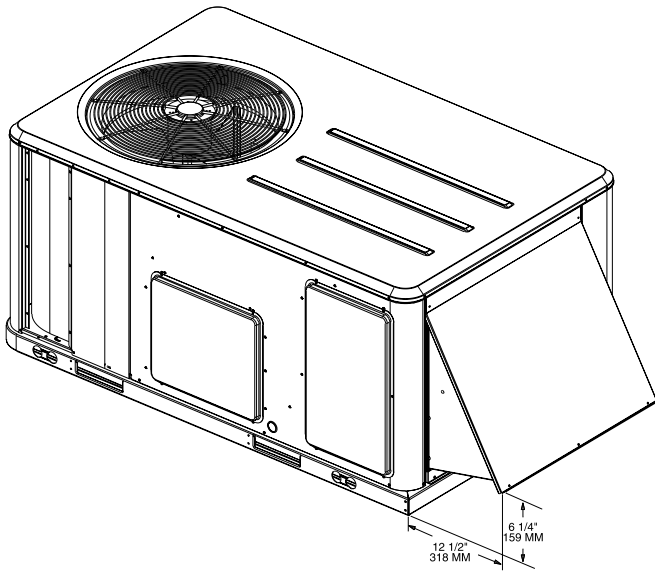

*TSC060 — Economizer , Manual or Motorized Fresh Air Damper*

*TSC060 — Barometric Relief Damper Hood*

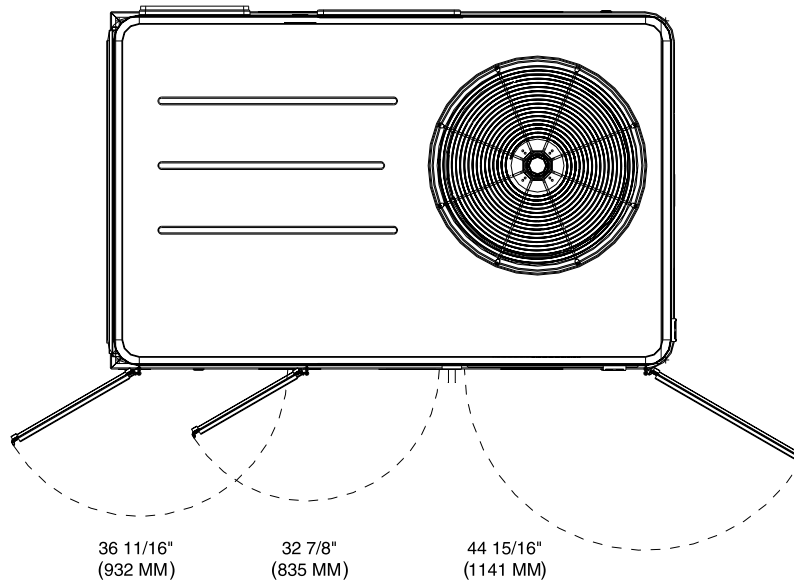

*TSC060 — Swing Diameter for Hinged Doors Option*

# Dimensional Data

# TSC072-120 Options/Accessories

All dimensions are in inches/millimeters.

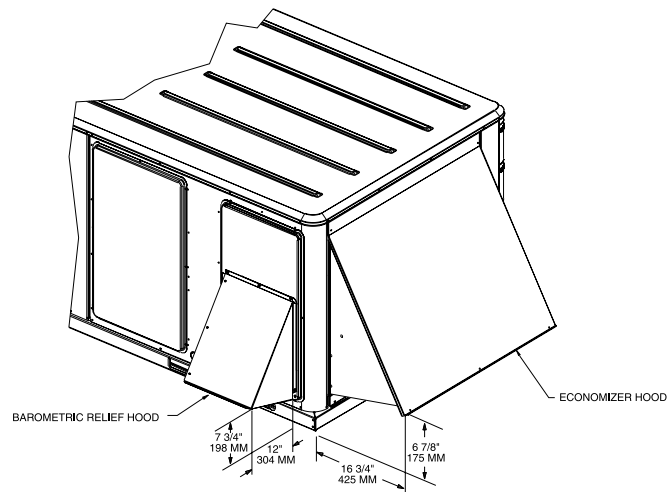

***TSC072-120 — Economizer and Barometric Relief Damper Hoods***

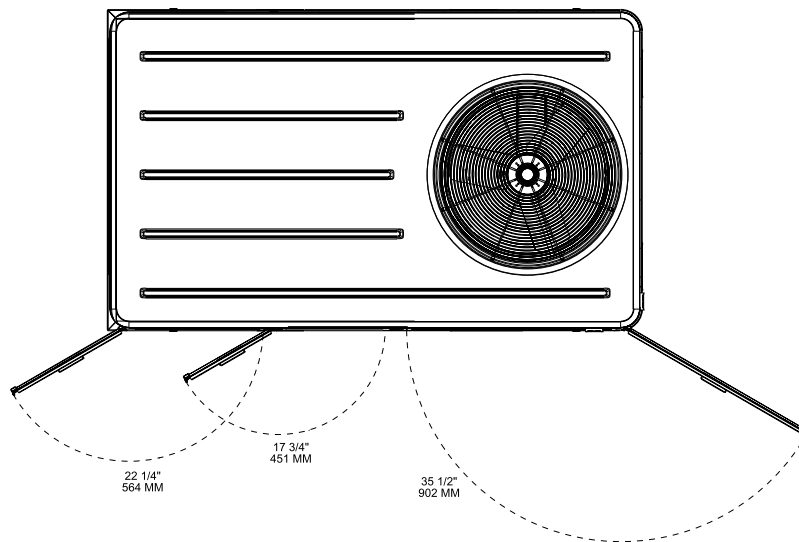

***TSC072-120 — Swing Diameter for Hinged Door(s) Option***

# Weights

**Table W-1 - Maximum Unit and Corner Weights and Center of Gravity Dimensions (SI)**

Unit Model No.	Maximum Weights <sup>(2)</sup> (kg)		Corner Weights <sup>(1)</sup> (kg)				Center of Gravity (mm)	
	Shipping <sup>(2)</sup>	Net <sup>(2)</sup>	A	B	C	D	Length	Width
TSC060AD	259	235	75	56	48	56	790	480
TSC072AD	365	326	107	83	58	78	970	560
TSC090AD	428	389	131	101	67	89	970	530
TSC102AD	445	405	133	106	72	94	990	560
TSC120AD	485	445	147	115	81	104	990	560

Notes:

- (1) Corner weights are given for information only. All models must be supported continuously by a curb or equivalent frame support.
- (2) Weights are approximate.

**Table W-1a - Maximum Unit and Corner Weights and Center of Gravity Dimensions (IP)**

Unit Model No.	Maximum Weights (lbs)		Corner Weights <sup>(1)</sup> (lbs)				Center of Gravity (in)	
	Shipping <sup>(2)</sup>	Net	A	B	C	D	Length	Width
TSC060AD	572	518	165	124	105	124	31	19
TSC072AD	805	718	235	182	128	173	38	22
TSC090AD	944	857	289	222	148	197	38	21
TSC102AD	980	893	294	233	159	207	39	22
TSC120AD	1069	982	323	253	178	229	39	22

Notes:

- (1) Corner weights are given for information only. All models must be supported continuously by a curb or equivalent frame support.
- (2) Weights are approximate.

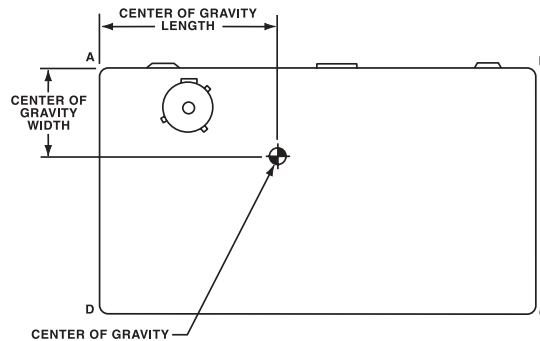

**Table W-2 - Accessory Net Weights<sup>(1) (2)</sup> (kg)**

Accessory <sup>(3)</sup>	Net Weights <sup>(2)</sup>	
	TSC060	TSC072-120
Economizer	12	16
Barometric Relief	3	5
Motorized Outside Air Damper	9	14
Manual Outside Air Damper	7	12
Roof Curb	32	52
Oversized Motor	2	4
Coil Guards	5	9
Hinged Doors	5	5
Electric Heaters	7	14

Notes:

- (1) Weights for options not listed are < 3 kg.
- (2) Net weight should be added to unit weight when ordering factory-installed accessories.
- (3) Some accessories not available on all units.

**Table W-2a - Accessory Net Weights<sup>(1) (2)</sup> (lbs)**

Accessory <sup>(3)</sup>	Net Weights <sup>(2)</sup>	
	TSC060	TSC072-120
Economizer	26	36
Barometric Relief	7	10
Motorized Outside Air Damper	20	30
Manual Outside Air Damper	16	26
Roof Curb	70	115
Oversized Motor	5	8
Coil Guards	12	20
Hinged Doors	10	12
Electric Heaters	15	30

Notes:

- (1) Weights for options not listed are < 5 lbs.
- (2) Net weight should be added to unit weight when ordering factory-installed accessories.
- (3) Some accessories not available on all units.

# Mechanical Specifications

---

## General

The units shall be convertible airflow. The operating range shall be between 46°C and -18°C (115°F and 0°F) in cooling as standard from the factory for all units. All units shall be factory assembled, internally wired, fully charged with R-22, and 100 percent run tested to check cooling operation, fan and blower rotation, and control sequence before leaving the factory. Wiring internal to the unit shall be colored and numbered for simplified identification.

## Casing

Unit casing shall be constructed of zinc coated, heavy gauge, galvanized steel. Exterior surfaces shall be cleaned, phosphatized, and finished with a weather-resistant baked enamel finish. Cabinet construction shall allow for all maintenance on one side of the unit. Service panels shall have lifting handles and be removed and reinstalled by removing only a single fastener while providing a water and air tight seal. All exposed vertical panels and top covers in the indoor air section shall be insulated with a cleanable foil-faced, fire-retardent permanent, odorless glass fiber material. The base of the unit shall be insulated with 13 mm, 16 kg (1/2 inch, 1 pound) density foil-faced, closed-cell material. All insulation edges shall be either captured or sealed. The unit's base pan shall have no penetrations within the perimeter of the curb other than the raised 29 mm (1 1/8 inch high downflow supply/return openings to provide an added water integrity precaution, if the condensate drain backs up. The base of the unit shall have provisions for forklift and crane lifting, with forklift capabilities on three sides of the unit.

## Unit Top

The top cover shall be one piece construction or where seams exist, it shall be double-hemmed and gasket-sealed. The ribbed top adds extra strength and prevents water from pooling on unit top.

## Filters

One inch, throwaway filters shall be standard on all 5 ton units. The filter rack can be converted to two inch capability. 50 mm (2 inch) filters shall be factory supplied on all 6-10 ton units. Optional 50 mm (2 inch) pleated filters shall be available.

## Compressors

All units shall have direct-drive, hermetic, scroll type compressors with centrifugal type oil pumps. Motor shall be suction gas-cooled and shall have a voltage utilization range of plus or minus 10 percent of unit nameplate voltage. Internal overloads shall be provided with the scroll compressors. Low and high pressure switches shall be standard.

## Refrigerant Circuits

Service pressure ports, and refrigerant line filter driers are factory-installed as standard. An area shall be provided for replacement suction line driers.

## Evaporator and Condenser Coils

Internally finned, 8 mm (5/16") copper tubes mechanically bonded to a configured aluminum plate fin shall be standard. Coils shall be leak tested at the factory to ensure the pressure integrity. The evaporator coil and condenser coil shall be leak tested to 1375 kPa (200 psig) and pressure tested to 3100 kPa (450 psig). The condenser coil shall have a patent pending 1 + 1 + 1 hybrid coil designed with slight gaps for ease of cleaning. A removeable, reversible, double-sloped condensate drain pan with provision for through the base condensate drain is standard.

## Outdoor Fans

The outdoor fan shall be direct-drive, statically and dynamically balanced, draw-through in the vertical discharge position. The fan motor shall be permanently lubricated and shall have built-in thermal overload protection.

## Indoor Fan

All units shall have belt drive motors. Units with belt drive motors shall have an adjustable idler-arm assembly for quick-adjustment to fan belts and motor sheaves. All motors shall be thermally protected. Oversized motors shall be available for high static operations.

## Controls

Unit shall be completely factory-wired with necessary controls and contactor pressure lugs or terminal block for power wiring. Units shall have single point power connection as standard. Unit shall provide an external location for mounting a fused disconnect device.

Microprocessor controls provide for all 24 volt control functions. The resident control algorithms shall make all heating, cooling, and/or ventilating decisions in response to electronic signals from sensors measuring indoor and outdoor temperatures. The control algorithm maintains accurate temperature control, minimizes drift from set point, and provides better building comfort. A centralized Microprocessor shall provide anti-short cycle timing and time delay between compressors to provide a higher level of machine protection.



# Mechanical Specifications

---

## Accessories/Options

**Electric Heaters** — Field-installed electric heat modules shall be available for installation within basic unit. Electric heater elements shall be constructed of heavy-duty nickel chromium elements internally delta connected for 200 volt, wye connected for 380-415 volt. Staging shall be achieved through the unitary control processor (UCP). Each heater package shall have automatically reset high limit control operating through heating element contactors. All heaters shall be individually fused from the factory, where required. Power assemblies shall provide single-point connection.

**Roof Curb** — The roof curb shall be designed to mate with the unit's downflow supply and return and provide support and a water tight installation when installed properly. The roof curb design shall allow field-fabricated rectangular supply/return ductwork to be connected directly to the curb. Curb shall be shipped knocked down for field assembly and shall include wood nailer strips.

**Economizer** — This accessory shall be either field or factory-installed and shall be available with or without barometric relief. The assembly includes fully modulating 0-100 percent motor and dampers, minimum position setting, preset linkage, wiring harness with plug, spring return actuator and fixed dry bulb control. The barometric relief shall provide a pressure operated damper that shall be gravity closing and shall prohibit entrance of outside air during the equipment "off" cycle. Optional solid state or differential enthalpy control shall be available for either factory or field installation. The factory-installed economizer arrives in the shipping position and shall be moved to the operating position by the installing contractor.

**Remote Potentiometer** — The minimum position setting of the economizer shall be adjusted with this accessory.

**Manual Outside Air Damper** — Factory or field-installed rain hood and screen shall provide up to 50 percent outside air.

**Motorized Outside Air Dampers** — Factory or field-installed manually set outdoor air dampers shall provide up to 50 percent outside air. Once set, outdoor air dampers shall open to set position when indoor fan starts. The damper shall close to the full closed position when indoor fan shuts down.

**Discharge Air Sensing** — This factory or field-installed option provides true discharge air sensing in heating models. This sensor is a status indicator readable through Tracer™ or Tracker™.

**Oversized Motors** — Factory or field-installed oversized motors shall be available for high static applications.

**Clogged Filter/Fan Failure Switch** — A dedicated differential pressure switch is available, factory-installed, to achieve active fan failure indication and/or clogged filter indication. These indications will be registered with either a zone sensor with status indication lights or an Integrated Comfort™ System.

# Mechanical Specifications

---

**High Pressure Cutout** — Standard on all units.

**Hinged Access Doors** — Sheet metal hinges are available factory-installed on the Filter/Evaporator, Supply Fan/Heat, and the Compressor/Control Access Doors.

**Black Epoxy Coated Condenser Coil** — The coil provides corrosion protection to condenser coils for seacoast application. The protection is a factory-applied thermoset vinyl coating, bonded to normal aluminum fin stock. The uniform thickness of the bonded vinyl layer exhibits excellent corrosion protection.

## Control Options

**Comm-3/4 Trane Communication Interface** — This factory or field-installed option shall be provided to interface microprocessor controlled units with the Trane Integrated Comfort™ systems.

**Comm-5 LonTalk Communication Interface** — This factory or field-installed option shall be provided to allow the unit to communicate as a Trane Comm-5 device or directly with generic LonTalk Network Building Automation System Controls.

**Zone Sensor** — This field-installed control shall be provided to interface with the Micro equipped units and shall be available in either manual, automatic programmable with night setback, with system malfunction lights, or remote sensor options.

**Thermostats** — Two stage heating and cooling operation or one stage heating and cooling shall be available, for field installation, in either manual or automatic changeover. Automatic programmable electronic with night set back shall also be available.

**Differential Pressure Switches** — These factory or field-installed sensors allow individual fan failure and dirty filter indication for microprocessor controlled units. The fan failure switch will disable all unit functions and “flash” the Service LED on the zone sensor. The dirty filter switch will light the Service LED on the zone sensor and will allow continued unit operation.

**Reference Enthalpy Control** — Replaces the dry bulb control with a wet bulb changeover controller which has a fully adjustable set point. Enthalpy control offers a higher level of comfort control, along with energy savings potential, than the standard dry bulb control. This is due to the additional wet bulb sensing capability. This option shall be available for microprocessor controlled units. It can be field-installed, or factory-installed with the factory-installed economizer.

**Differential Enthalpy Control** — Replaces the standard dry bulb control with two enthalpy sensors that compare total heat content of the indoor air and outdoor air to determine the most efficient air source. This control option offers the highest level of comfort control, plus energy efficiency, available. This option shall be available for microprocessor controlled units. It can be field-installed, or factory-installed with the factory-installed economizer.

**Low Ambient Cooling** — All microprocessor units shall have cooling capabilities down to 18°C (0°F) as standard.



**Trane**  
**A business of American Standard Companies**  
**[www.trane.com](http://www.trane.com)**

*For more information, contact your local district office or e-mail us at [comfort@trane.com](mailto:comfort@trane.com)*

---

Literature Order Number	RT-PRC016-EN
File Number	PL:UN-000-RT-PRC016-EN-11-03
Supersedes	PL:UN-000-RT-PRC016-EN-10-03
Stocking Location	03-03 Webb/Mason 11-03 Electronic Only

---

*Trane has a policy of continuous product and product data improvement and reserves the right to change design and specifications without notice*