



**Hot beverage vending Machine**

# **RUBINO 200**

# **RUBINO 200 T.T.T.**

**Model:**

**ESPRESSO**



**TYPE: SG200E**



**OPERATION AND MAINTENANCE**

**WARNING:** This instruction manual is intended exclusively for specialized personnel.

For more information visit [www.Gumball.com](http://www.Gumball.com) | 800-260-0010 | +1-214-550-5079

# MAIN PARTS

## RUBINO 200

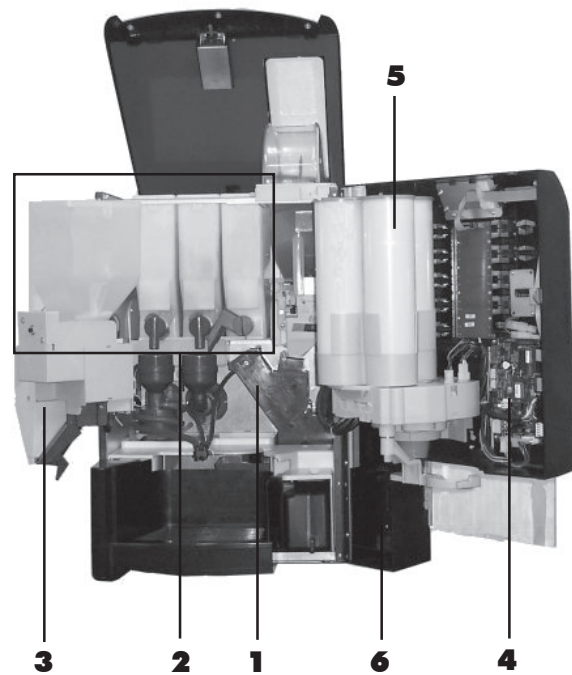
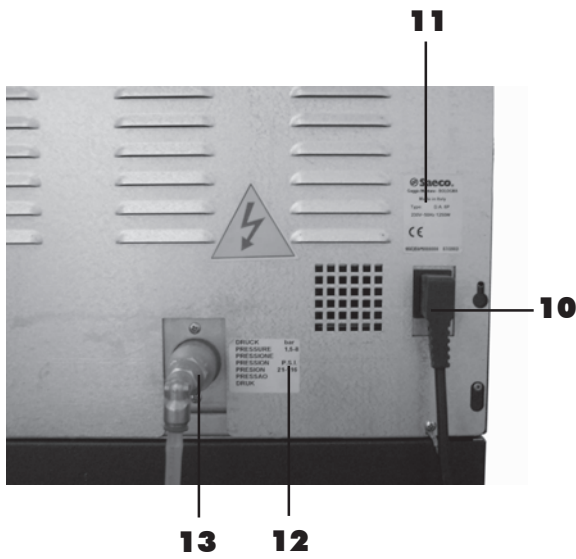

## RUBINO 200 T.T.T.

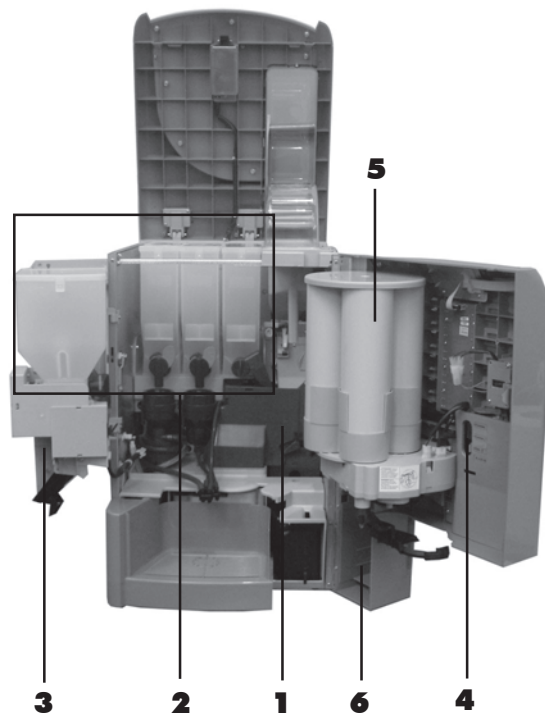
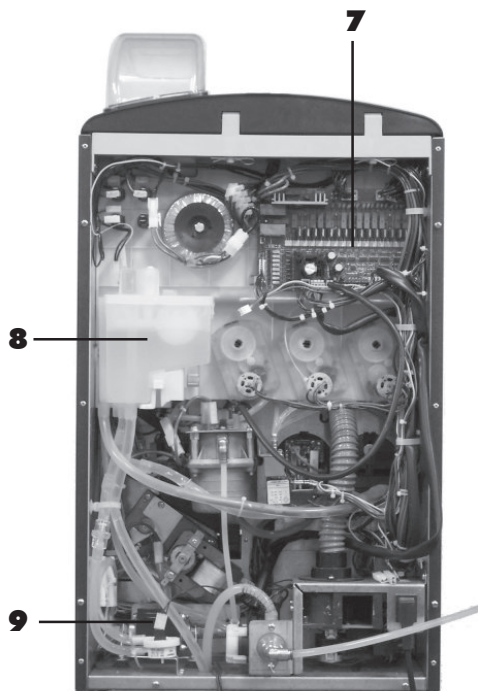

- 1** Brew group and coffee grinder
- 2** Brewing hopper group
- 3** Sugar and stirrer dispensing group
- 4** CPU card
- 5** Cup dispenser
- 6** Payment system area
- 7** POWER card

- 8** Water circuit equipped with air-break device
- 9** Pump
- 10** Tray socket
- 11** Data plate
- 12** Data plate showing the minimum and maximum water pressure
- 13** Water mains connection

# TABLE OF CONTENTS

<b>1 - INTRODUCTION TO THE MANUAL .....</b>	<b>4</b>	<b>7 - PAYMENT SYSTEM INSTALLATION .....</b>	<b>24</b>
1.1 Foreword .....	4	7.1 Payment system installation on the machine .....	24
1.2 Symbols used .....	4	7.2 Payment system installation on the cabinet .....	25
1.3 General instructions.....	5	<b>8 - PROGRAMMING AND MAINTENANCE MENU .....</b>	<b>26</b>
1.4 Operator requirements .....	7	8.1 Description of programming and maintenance phase keys	27
<b>2 - TECHNICAL SPECIFICATIONS</b>	<b>7</b>	8.2 Programming menu	27
<b>3 - SAFETY STANDARDS .....</b>	<b>8</b>	8.2.1 Entering the programming menu	27
3.1 Foreword .....	8	8.2.2 Structure of the programming menu	35
3.2 General safety rules .....	8	8.2.3 Functions of the programming menu	35
<b>4 - HANDLING AND STORAGE ..</b>	<b>9</b>	8.3 Maintenance menu	46
4.1 Handling and transport .....	9	8.3.1 Access to the maintenance menu	46
4.2 Storage .....	9	8.3.2 Description of maintenance menu messages	48
4.3 Packaging .....	10	8.4 Software updating (machine re-programming)	51
<b>5 - GENERAL TECHNICAL DESCRIPTION .....</b>	<b>10</b>	<b>9 - MAINTENANCE AND INACTIVITY .....</b>	<b>52</b>
5.1 Permitted use .....	10	9.1 Cleaning and loading .....	52
5.2 Versions and Models .....	10	9.1.1 Daily cleaning .....	52
5.3 Basic operating concepts .....	10	9.1.2 Weekly cleaning .....	54
<b>6 - INSTALLATION .....</b>	<b>13</b>	9.1.3 Product loading .....	55
6.1 Positioning .....	13	9.2 Maintenance .....	55
6.2 Receipt .....	14	9.2.1 Scheduled and unscheduled maintenance .....	56
6.3 Unpacking .....	15	9.2.2 Brew group maintenance .....	56
6.4 Water mains connection .....	16	9.3 Adjustments .....	57
6.5 Electric mains connection .....	16	9.3.1 Dose and grinding adjustment .....	57
6.6 Machine start-up .....	17	9.4 Cup releasing device cleaning and .....	58
6.7 Installation .....	18	adjustment .....	58
6.7.1 Cleaning and filling of resin-based water softener .....	18	9.5 Resin regeneration - where the water .	60
6.7.2 Water circuit filling .....	19	softner is provided .....	60
6.7.3 Cleaning the parts in contact with foodstuff .....	20	<b>10 - INACTIVITY .....</b>	<b>61</b>
6.8 Product loading .....	21	<b>11 - DISMANTLING .....</b>	<b>61</b>
6.8.1 Container loading .....	21	<b>12 - TROUBLESHOOTING GUIDE FOR THE MOST COMMON FAILURES OR ERRORS .....</b>	<b>62</b>
6.8.2 Label insertion .....	22	<b>13 - VISUAL SIGNALS (LEDs) .....</b>	<b>66</b>
6.8.3 Cup loading .....	22	<b>14 - INSTRUCTIONS FOR END-OF-LIFE DISPOSAL TREATMENT .....</b>	<b>69</b>
6.8.4 Stirrer loading .....	23		

# 1 - INTRODUCTION TO THE MANUAL

## 1.1 Foreword



### Important

This publication is an integral part of the machine and should be read carefully in order to use it in a correct way. Complying with safety requirements is also essential

This manual contains the technical information necessary to carry out the procedures of use, cleaning, installation and maintenance of the vending machine mod. RUBINO 200 correctly. Always consult this publication before carrying out any operation.

Manufacturer: **Saeco International Group**  
Via Panigali, 39 - 40041 Gaggio Montano (BO).

This manual should be kept with care and go with the machine throughout its operational life, also in case of changes of ownership.

If this manual should be lost or worn out, it is possible to require another copy to the Manufacturer or to an Authorized Service Centre. In this event, please indicate the data on the plate located on the back of the machine.

All the images in this manual refer to the RUBINO 200 model.

The data that refers to a single model is indicated.

## 1.2 Symbols used

A number of symbols are used in this manual to classify situations according to their degree of danger, and that require technicians with different skills.

The symbol is integrated with a message suggesting operating procedures or behaviours and providing useful information concerning the machine performance.



### Warning

This symbol indicates dangerous situations for the users, supply operators and maintenance technicians dealing with either the vending machine or the product to be dispensed.



### Important

This symbol indicates operations that keep the machine in good working conditions, if properly carried out.



### Recommended solutions

This symbol indicates the procedures that make the programming and/or maintenance operations quicker.



### User

This symbol indicates the machine user, who is not authorized to clean or service the vending machine.



### Supply operator

It is used to indicate operations to be exclusively carried out by personnel in charge of machine supplying and cleaning.

Maintenance is exclusive task of the maintenance technician, and cannot be performed by the supply operator.



### Maintenance technician

This symbol is used to indicate operations to be only performed by specialized maintenance personnel.

The maintenance technician is the only person authorized to keep the MAIN SWITCH ACTIVATION KEY, which allows disabling the safety system.



## Read

This symbol indicates that the user should read the instruction manual carefully before operating the machine.

### 1.3 General instructions



## Warning

*Before using the vending machine, read this manual carefully. A good knowledge of the information and instructions contained in this document is essential for a correct use of the vending machine, in compliance with essential safety requirements.*



## Warning

*L'addetto al rifornimento non deve per alcun motivo accedere a quelle parti del distributore automatico le cui protezioni sono bloccate da mezzi che richiedano un utensile per essere liberati.*

*For no reason whatsoever should the personnel in charge of the machine reach those parts of the machine that are protected by guards requiring special instruments for their removal.*

Some maintenance operations (to be carried out solely by specialised technicians) expressly require that certain safety devices be switched off.

knowledge and absolute respect, from a technical point of view, of the safety standards and warnings contained in this manual, are fundamental for installing, using and servicing the machine under reduced risk conditions.

- It is the buyer's responsibility to ascertain that the machine operators have been trained and informed of all the indications and specifications contained in the documentation supplied. Even so, the operator should be aware of the potential risks that exist while operating the automatic vending machine.
- Operating reliability and the efficiency of the machine performance are guaranteed only if original spare parts are used.
- The user will be held entirely responsible for any modifications made on the machine. All the operations necessary to keep the machine in good working order, before and during use, are user's duty.
- Altering and tampering with the machine without prior consent of the manufacturer, will release the latter from any liability for any damage or injury resulting from, or connected to the above modifications.
- This manual reflects the state of the art of the automatic vending machine at the moment of the issue on the market. Possible modifications, improvements or adjustments that are made to machines that are subsequently marketed, do not oblige the Saeco International Group either to intervene on the previously supplied machine or consider it and the relevant manual to be defective or inadequate.
- Vending machine operator is only allowed for interventions under his own responsibility and specialization.  
The user should have a good knowledge of all mechanisms of the machine, as far as he is concerned.

- However, the Saeco International Group, whenever necessary and for valid reasons is entitled to update existing manuals and send to his customers all updating sheets that have to be kept with the original manual. Any technical problems that may arise can easily be solved by consulting this manual. For further information, contact the dealer where the machine was purchased, or one of the authorized service centres.

When calling, please, provide the following information:

- the data written on the *data plate* located on the rear side of the vending machine (fig. 1)

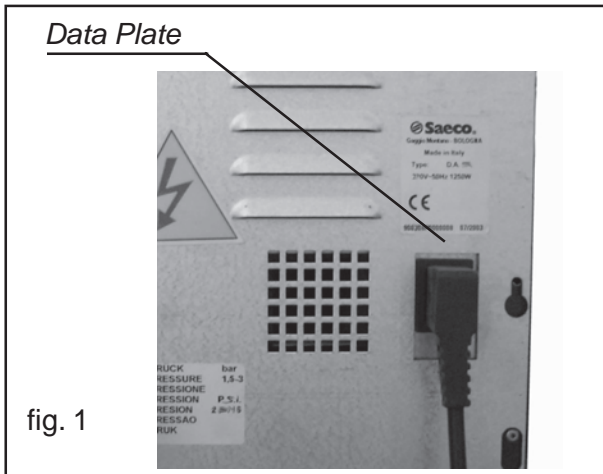

- The program version in the microprocessor (see adhesive label on the component mounted on the CPU card) (ref.'1', fig. 2).

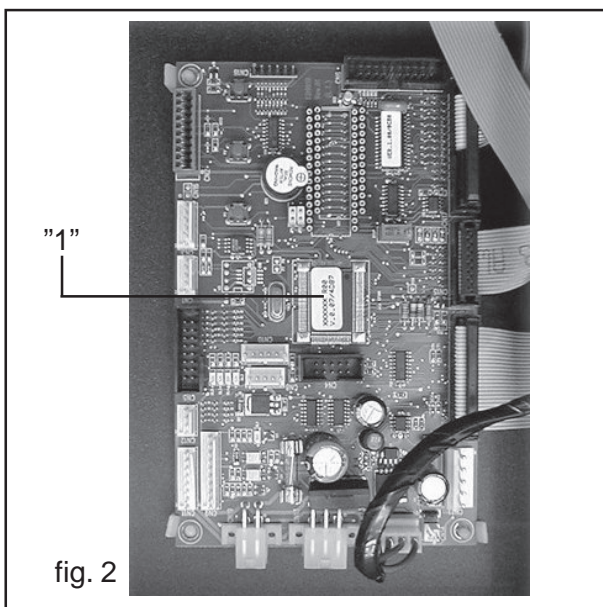

- The card code and version, to be found on the component side of the CPU card (ref.'2', fig. 2).

**Warning**

It is absolutely forbidden to tamper with or modify the data plate.

The Saeco International Group declines all responsibility for injuries to people or damage to things resulting from:

- incorrect installation
- inappropriate electrical and/or water connection
- inadequate cleaning and maintenance
- unauthorized modification
- improper use of the vending machine
- non-original spare parts

- The Saeco International Group will not be obliged in any case to indemnify any damage caused as a result of the forced inactivity of the machine due to failure.

- Installation and maintenance must be only carried out by qualified technicians.

- Use only specific foodstuffs suitable for vending machines.

- The automatic vending machine is not suitable for outside installation. The machine must be installed in dry places, with temperatures not below 1°C and it must not be installed in places where cleaning is made with water hoses (e.g. large kitchens, etc.).

- If at the time of installation, the usage conditions are different from those established or are subject to change over time, please contact the manufacturer immediately before using the machine. Furthermore, always act in compliance with national or local standards.

## 1.4 Operators requirements

To guarantee safety, three different machine users are to be distinguished, each having specific characteristics:



### User

Access to the inside of the machine is forbidden to the user.



### Supply operator

The safekeeping of the access key to the inside of the machine is entrusted to the Supply operator by the Maintenance Technician. He has the task of supplying the products, external cleaning, activating and stopping the machine.



### Warning

The Supply Operator is not authorized to carry out operations that are indicated as competence of the Maintenance technician in this publication.



### Maintenance technician

Is the only person authorized to carry out and start programming procedures for adjusting, setting up and upkeep the machine.

## 2 - TECHNICAL SPECIFICATIONS

Weight	40 Kg
Overall dimensions	See fig. 3



Power consumption	see <i>Data plate (fig. 1)</i>
Mains voltage:	see <i>Data plate (fig. 1)</i>
Electric voltage frequency.	see <i>Data plate (fig. 1)</i>
Power cord length	1,600 mm
Connection to water mains	3/8 gas type
Water system pressure:	from 1.5 up to 8 bar (fig. 4)
A-Weighted sound pressure level:	lower than 70 db

**Data plate showing the minimum and maximum water pressure**

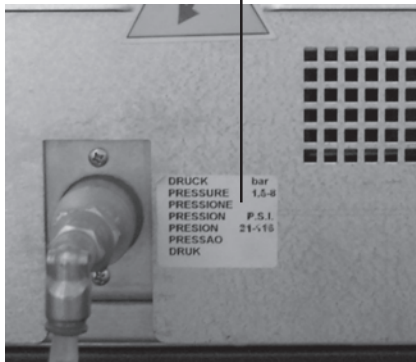

fig. 4

### CUP DISPENSER

suitable for cups with 70-71 mm dia. and for cups with 73 mm dia. through an adequate release ring.

### BOILER HEATING ELEMENTS

armoured types:  
from 1,000 Watt for coffee boiler

### CONTAINER CAPACITY

Coffee beans	2.0 Kg
Instant coffee	0.6 Kg (instead of tea)
Granular milk	0.85 Kg
Chocolate	1.7 Kg (or 2.6)
Tea	2.0 Kg
Sugar	2.0 Kg
Cups	195
Stirrers	185



### Important

To guarantee the correct functioning and durability of the vending machine, follow the indications below:

- room temperature: from +1°C to +40°C
- maximum humidity: 90% (without condensation water)

## 3 - SAFETY STANDARDS

### 3.1 Foreword

In compliance with the Machine Directive 98/37/EEC, Low Tension Directive 73/23/EEC and CE Marking Directive 93/68/EEC, the Saeco International Group has drawn up a technical file on RUBINO 200 vending machine at its plants, acknowledging during the design phase the regulations listed in the Declaration of Conformity inside any vending machine.

### 3.2 General safety rules



#### Warning

- Before using the vending machine, read this manual carefully.
- Installation and maintenance must only be carried out by qualified technicians.
- For no reason whatsoever shall the operator reach those parts of the machine that are protected by guards requiring special instruments for removal.
- Good knowledge and absolute respect, from a technical point of view, of the safety standards and danger warnings contained in this manual, are imperative for installing, using, servicing and maintaining the machine in minimum minimum risk conditions.



#### Warning

Always disconnect the POWER CABLE before servicing or cleaning the machine.  
Under no circumstances neither service the machine, nor remove safety guards before hot parts have cooled down!



- Operating reliability and the efficiency of the machine performance are only guaranteed if original spare parts are used.
- The automatic vending machine is not suitable for outside installation. The machine must be installed in dry places, with temperatures never below 1°C and it must not be installed in places where cleaning is made with water hoses (e.g. large kitchens, etc).
- In order to guarantee the performance of the machine, always keep the automatic vending machine in perfect cleaning conditions.
- The Saeco International Group declines all responsibility for injuries to people or damage to things as a consequence of:
  - Use individual protection devices during installation, testing and maintenance.
  - incorrect installation
  - inappropriate electrical and/or water connection
  - inadequate cleaning and maintenance
  - unauthorized modification
  - improper use of the vending machine
  - non-original spare parts



### Important

It is forbidden to:

- Tamper with or cut off the safety systems installed on the vending machine;
- Use water jets to clean the machine.

Furthermore, always act in compliance with national or local standards.



### Warning

*In case of failure or malfunctioning, contact exclusively qualified CUSTOMER SERVICE CENTER repairmen.*

## 4- HANDLING AND STORAGE

### 4.1 Handling and transport

The transport of the vending machine should be carried out by skilled personnel.

The vending machine is delivered on a pallet; for handling purposes use a fork lift truck and move it slowly in order to avoid any possible overturning or dangerous oscillations.



### Important

*Avoid:*

- lifting the vending machine with ropes or presses;
- dragging the vending machine
- turning over or laying down the vending machine during transport
- shaking the vending machine

*Avoid the machine:*

- being bumped into
- being overloaded with other parcels
- being exposed to rain, frost or heat sources
- being kept in damp places

### 4.2 Storage

In the event of storage, avoid any stacking of several machines, keep them in a vertical position, in dry places with temperatures not below 1°C.

### 4.3 Packaging

The vending machine is protected by cardboard angles, by a transparent polypropylene film and it is supplied in a box. The vending machine will be delivered in a package, so as to ensure protection against any mechanical and environmental agent.

Labels are applied on the packaging, indicating:

- handle with care
- do not overturn
- protect from rain
- do not stack
- protect from heat sources
- not shock resistant
- machine type and serial number



#### Important

*Once the transport is over, the packaging should be undamaged, which means it should not:*

- show any crushed parts, sign of shocks, buckling or breaking
- show wet parts or signs that could lead to suppose its exposure to rain, frost or heat
- show signs of tampering

## 5 - GENERAL TECHNICAL DESCRIPTION

### 5.1 Permitted use

The vending machine is to be used exclusively for the dispensing of beverages, prepared by mixing foodstuffs with water (by brewing, as to coffee).

To this purpose, use products that the manufacturer has declared as being suitable for vending in open containers. Beverages are brewed in suitable plastic cups, which the machine dispenses automatically. The stirrer used for mixing sugar is automatically dispensed. Beverage should be drunk at once and under no circumstances can they be kept for subsequent consumption.

### 5.2 Versions and models



#### Warning:

*This manual refers to the top-of-the -range model: it is therefore possible to find descriptions or explanations not relating to the machine you have.*

### 5.3 Basic operating concepts

During normal operation, the vending machine is in standby mode. By introducing the amount corresponding to the price displayed and by pressing the key relevant to the desired beverage, you will start the dispensing cycle. This one basically consists of:

### BEVERAGE SELECTION

The machine can dispense 8 beverages. A beverage can be selected according to the following conditions:

- the vending machine has reached the set temperature after start-up. Otherwise, once a key is pressed, the display shows the message ' PLEASE WAIT'.

- the available credit is sufficient or the vending machine has been set in free mode. If this is not the case, the display shows the message 'INSERT ...';
- there is no error condition that prevents beverage brewing. If it is not the case the display shows the error message 'BEVERAGE... OUT OF SERVICE' alternated to a 'NOT AVAILABLE' message;
- the selected beverage has been enabled. If this is not the case, the message 'NOT AVAILABLE' will be displayed;
- the selected beverage is not prevented. Otherwise, before pressing the key, the message 'BEVERAGE ...' alternated to a 'NOT AVAILABLE' message is displayed. After pressing the key, the display shows 'NOT AVAILABLE';

During hot beverage brewing:

- payment systems are disabled;
- the first line on the display shows the programmable dispensing message (default message is: 'WAIT FOR PRODUCT').

#### *Beverage selection*

If the vending machine has not been programmed to freely dispense beverages insert the required credit

Press the key corresponding to the beverage requested. After beverage dispensing, the message 'REMOVE CUP' is displayed. Take the beverage from the dispensing outlet.



#### **Warning**

Not to burn your hand, wait for the signal - 'REMOVE CUP' - before introducing your hand. Do not open the dispensing outlet door while the VM is brewing.

In case of failures or product missing during the brewing phase, the display indicates the causes.

### **CUP, SUGAR AND STIRRER DISPENSING**

This is the first operation that the vending machine activates (except for 'without cup' dispensing selection):

- the cup bracket motor is activated and moves under the cup chute. At the same time, it operates the cup scrolls to separate the first cup and let it drop into the special support fork.
- The same motor draws the cup under the sugar dispenser – there it stops for 2 seconds. In this way dispensing is enabled and, where it is set or required, a stirrer is dispensed. Finally, it sets the cup under the beverage brewing nozzles.
- The stirrer dispensing is controlled through a solenoid which actuates the stirrer ejector. The stirrer is then dropped into the cup by means of the proper chute.

When selecting a beverage, sugar is dosed through a motor that activates the sugar hopper screw.

### **INSTANT BEVERAGE BREWING**

This process takes place after dispensing of cup, sugar and stirrer.

According to the type of beverage selected and machine model, the following processes are activated.

- If present, the motor mixer starts.
- the instant product solenoid valve (ref.'1' fig.5), located on the coffee boiler, starts and allows to fill the mixer with the preset amount of water. The pump (ref.'2' fig.5) is then activated and the preset amount of water dispensed, under the control of an appropriate electronic device (volumetric meter) (ref.'3' fig.5).

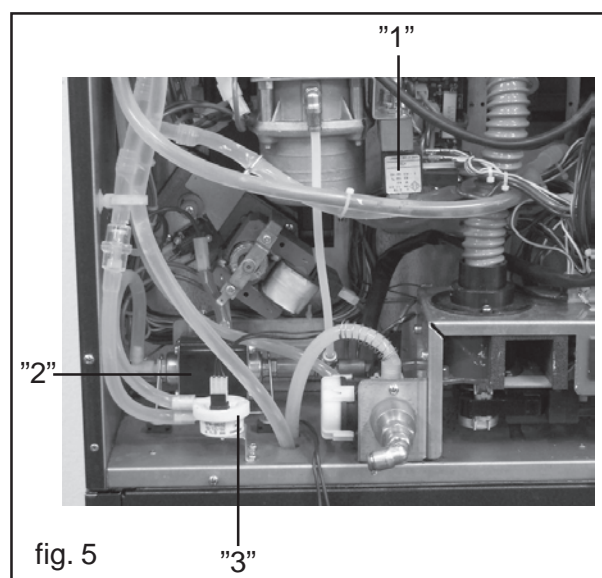

fig. 5

- the gear motor of the instant product activates the screw, dispensing the desired amount of product into the mixer.
- once the pre-set amount of water and product is dispensed, the mixer is disconnected.

## ESPRESSO COFFEE BREWING

This process takes place only after the dispensing of cup, sugar and stirrer.

- the grinder (ref.1 fig.6) is activated until the quantity of coffee set on the dosing unit (ref.2 fig.6) is reached
- the activation of the dosing unit solenoid (ref. '3' fig. 6) causes the door to open and, as a consequence, the coffee is dispensed into the cup.

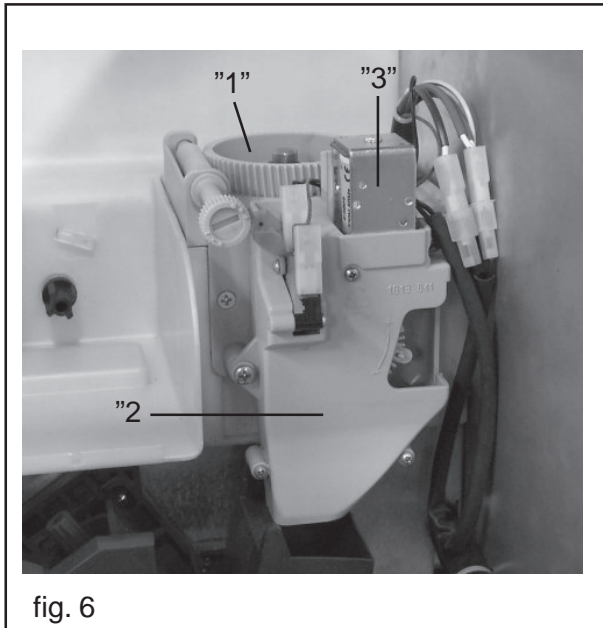

fig. 6

- the unit rotation gear motor activates, thus moving the unit to the brewing position. The coffee tablet is pressed simultaneously.
- the pump brewing the set quantity of water activates, under the control of an appropriate electronic device (volumetric meter) (ref. '3' fig. 5).
- the brew group gear motor is restarted, and goes back to the rest position. During this movement the coffee tablet is ejected.

The grinder and dosing unit activation sequence can take place in reverse order, according to the program selected (see programming menu).

## FRESH BREW WITH PRE-GROUND COFFEE

- unlike the figure of the espresso coffee brewing, the fresh brew coffee cycle with preground coffee does neither imply the activation of the coffee grinder nor of the doser soleoid. The gearmotor of the pre-ground coffee, contained in the third instant product container, activates the screw conveyor so

as to dispense the preset amount of product into the brewing cup through the appropriate channel.

- The group rotation gearmotor, which moves the group in an advance brewing position as regards to the one reached during the espresso coffee brewing, is activated. As a result, the compression of the coffee tablet is lower so as to obtain a beverage which is noticeably less full-bodied as regards to espresso coffee.
- The cycle ends as described above in the two final phases of the espresso coffee brewing.

## FRESH BREW WITH COFFEE BEANS

- As for the espresso coffee brewing, the brewing cup is filled through the activation of the coffee grinder and, then, of the doser solenoid.
- The group rotation gearmotor, which moves the group in an advance brewing position as regards to the one reached during the espresso coffee brewing, is activated. As a result, the compression of the coffee tablet is lower so as to obtain a beverage which is noticeably less full-bodied as regards to espresso coffee.
- The cycle ends as described above in the two final phases of the espresso coffee brewing.

## ESPRESSO WITH PRE-GROUND COFFEE

- As shown for the brewing of fresh brew coffee with pre-ground coffee, the espresso coffee cycle with pre-ground coffee does neither imply the activation of the coffee grinder nor of the doser soleoid. The gearmotor of the pre-ground coffee, contained in the third instant product container, activates the screw conveyor so as to dispense the preset amount of product into the brewing cup through the appropriate channel.
- the group rotation gearmotor, which moves the group to the brewing position and simultaneously compresses the coffee tablet, is activated.
- the pump is activated and dispenses the preset quantity of water under the control of an appropriate electronic device (volumetric counter) (ref. "3" fig. 5).  
The Brew Group gearmotor is activated again, and goes back to the rest position. During this movement the coffee tablet is ejected.

## 6 - INSTALLATION

### 6.1 Positioning



#### Warning

*The vending machine cannot be installed in external areas, avoid placing it in areas where the temperature is less than 1°C or more than 40°C and in particularly humid or dusty areas and it should not be installed in places subject to explosion or fire hazards, or where cleaning is done with water jets.*

- If positioned near a wall, there must be a minimum distance of at least 5 cm from the wall (fig. 7), so as to allow regular ventilation. Under no circumstances cover the vending machine with cloths or similar.

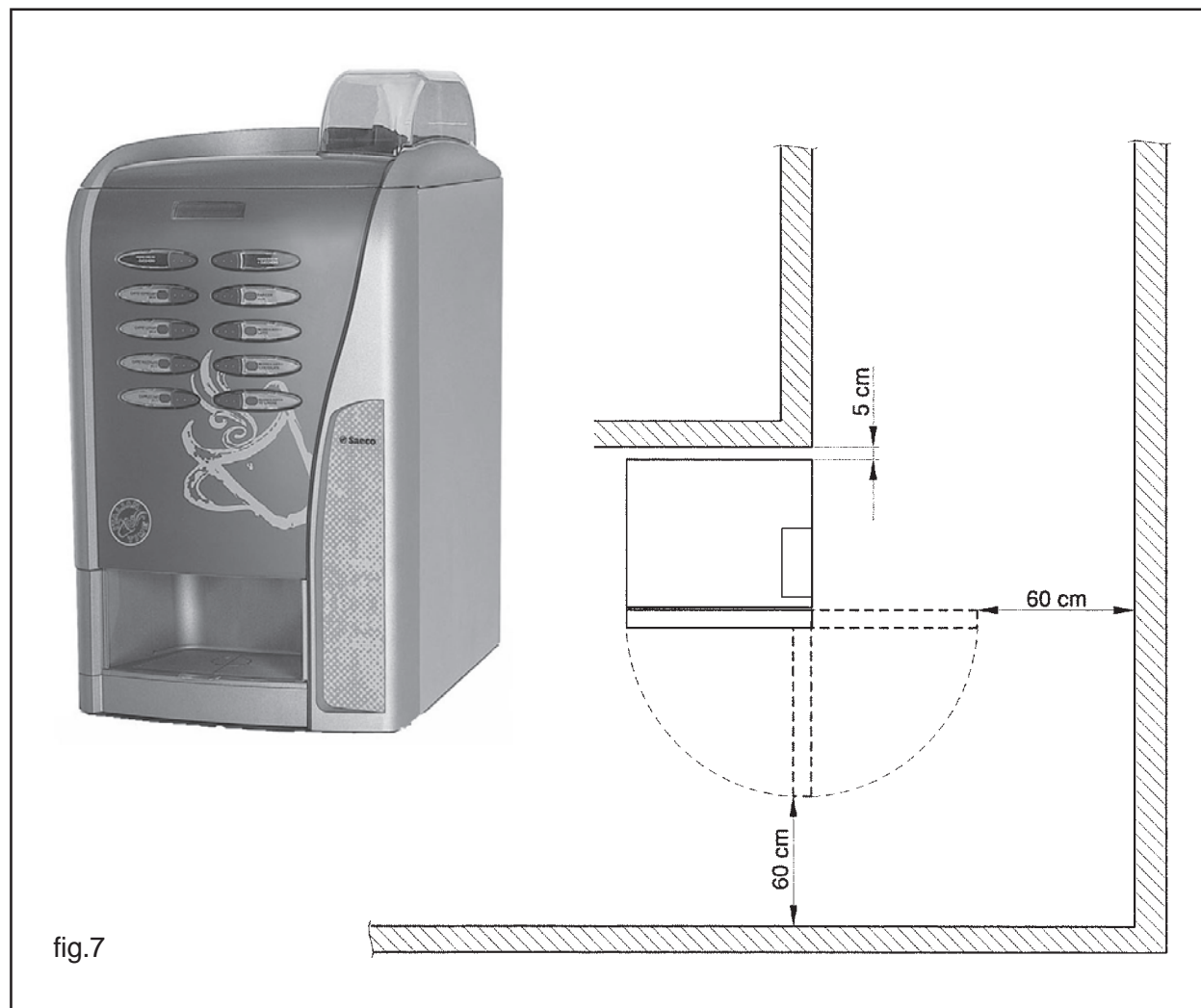

- When positioning the vending machine, check its levelling by means of the adjustable feet already fitted under the vending housing (fig. 8) or under the cabinet (fig. 9) Make sure that the vending machine does not have an inclination exceeding 2 degrees.

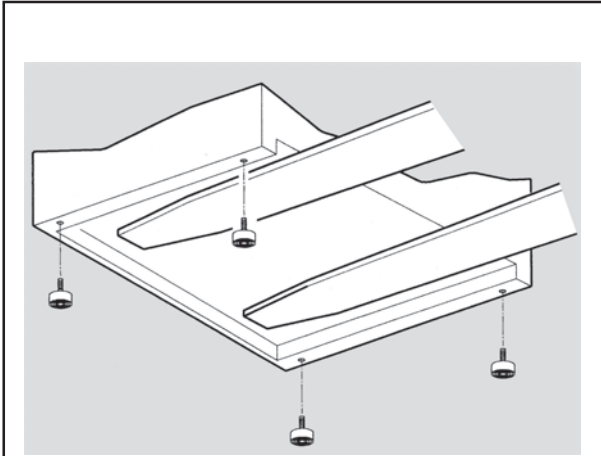

fig.8

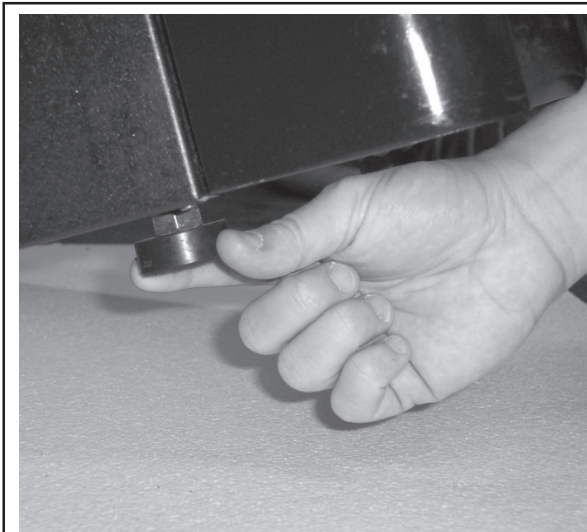

fig. 9

The **Saeco International Group** declines all responsibility for troubles due to the failure in observing the assembly rules.

If installation takes place in safety evacuation corridors, make sure that the machine with the door open assure sufficient space for people to pass by (fig. 7).

In order to avoid the floor from getting dirty as a result of accidental spillage of products, place a sufficiently wide protection to cover the working area under the vending machine.

## 6.2 Receipt



Upon receipt of the automatic vending machine, it is necessary to check it has not suffered damage during transport. If damage of any kind is noticed, immediately place a claim with the forwarder.

An envelope is supplied with the vending machine, called '**CUSTOMER KIT**'. It contains the objects shown in Fig. 10.

- Instruction manual.
- Powder tank plates and prices in euro.
- Push-button panel selection plates.
- Instruction plates.
- Wiring and hydraulic diagram.
- Power cord.
- Safety switch key (Technical engineer).
- Declaration of conformity



fig. 10

### 6.3 Unpacking

- Free the vending machine from the package.
- Remove the vending machine from the transport pallet. Unloose its fastening screws (fig. 11).

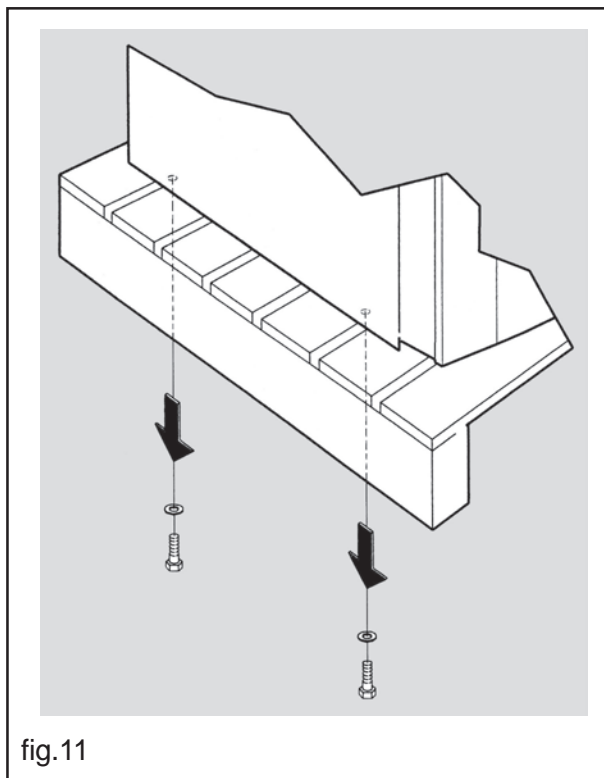

Open the door of the vending machine and remove the adhesive tape from the components concerned.

- Remove polystyrene securing internal components (fig. 13)

 **Warning:**

*The packing material must not be accessible to unauthorized people, as it is a potential source of danger. For the disposal please contact qualified companies.*

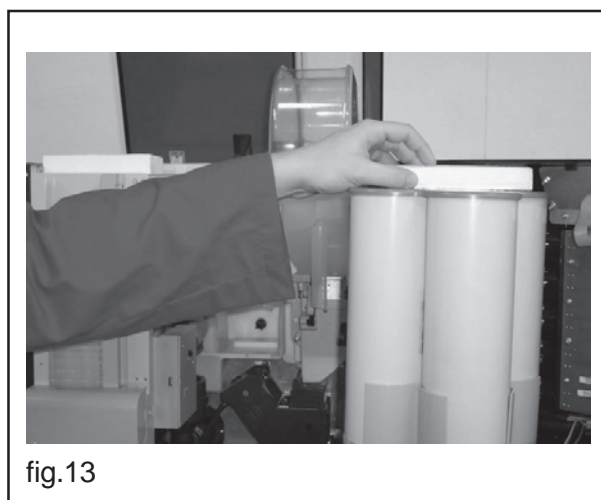

- Remove the key from the beverage dispensing outlet (fig. 12).



## 6.4 Water system connection

Before connecting the vending machine to the water mains, make sure that the water is:

- drinkable, if necessary by means of a test laboratory certification
- has a pressure ranging between 1.5 and 8 bar, otherwise use a pump or a water pressure reducer accordingly.
- if not already fitted, install a tap in an accessible position, so as to separate the equipment from the water mains, should it be necessary (fig. 14).

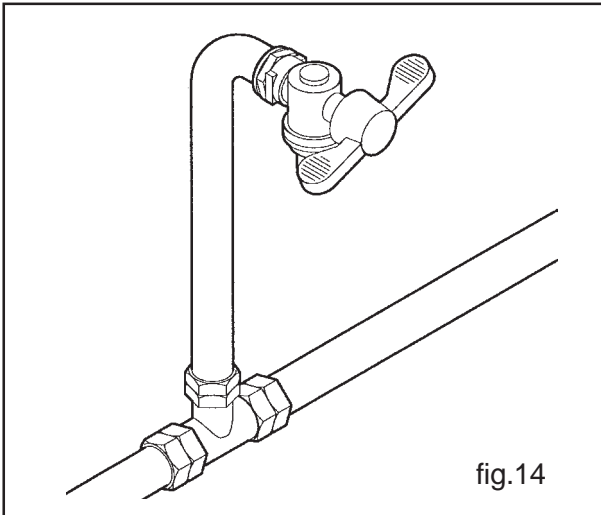

- let some water flow out of the tap in order to eliminate possible traces of impurities and dirt (fig.15).

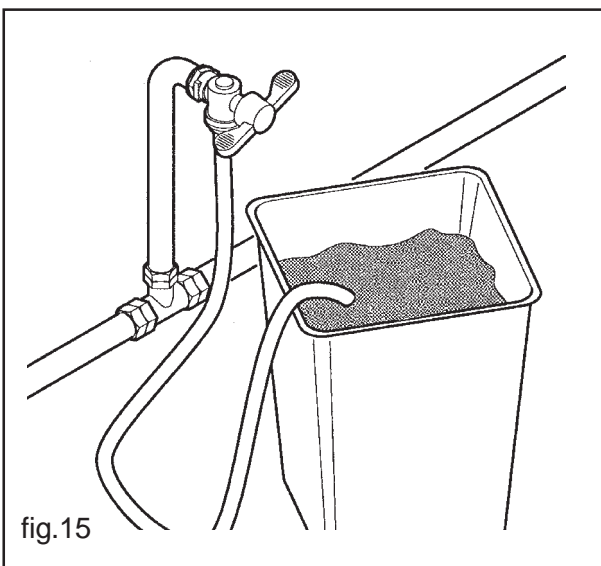

- connect the tap to the vending machine, using a copper or nylon hose, suitable for foodstuff and resistant to the supply pressure. Should a flexible hose be used, it is necessary to assemble the reinforcement bearing inside, supplied with the machine.

- Use a 3/8 gas-type connection.

## 6.5 Power supply connection



### Warning

The Maintenance Technician, who is responsible for the vending machine installation, must ensure that:

- the electric system complies with current regulations on safety;
- the mains voltage corresponds to that indicated on the data plate.

If in doubt, do not proceed with the installation but ask skilled personnel, qualified to carry out these tasks, to carefully check the system.

- The machine is equipped with power cord (fig.16)

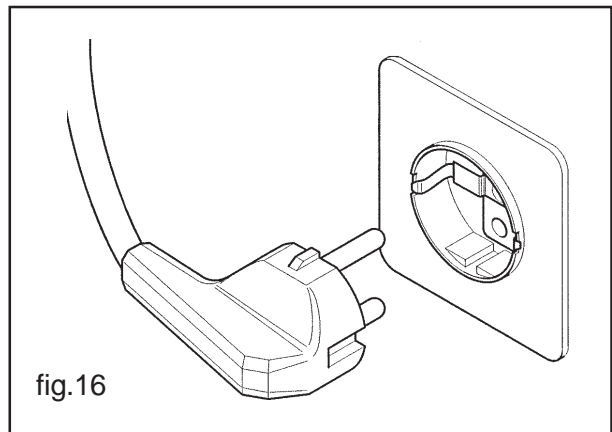



- The sockets that are not compatible with the plug of the machine should be replaced.
- The use of extensions, adapters and/or multiple plugs is forbidden (fig 17).

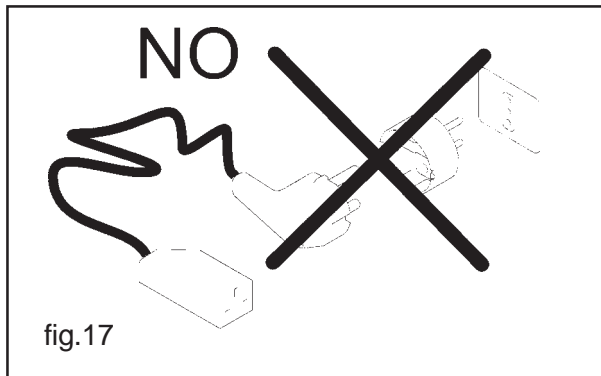

## 6.6 Machine start-up



The machine is equipped with a safety switch - located on its top cover (fig. 18) which disconnects the utilities whenever the door is opened (see wiring diagram).

Therefore, open the door or unplug the installation in case of need.

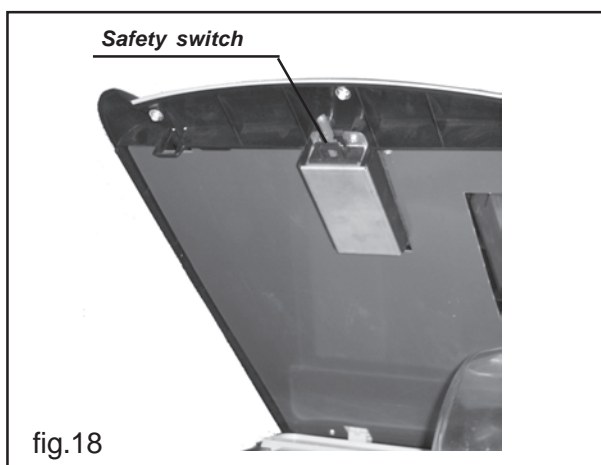

### Warning

*During the setting-up phase, before powering up the machine, make sure you have connected it to the hydraulic system and opened the water tap.*



### Warning

*The safety switch remains live (ref. '1', fig. 18)*

- For some operations, it is however necessary to operate with the door open but the vending machine connected to the mains.

Skilled technicians may operate in this way, by inserting the special plastic key, supplied with the machine, into the switch located on the machine top cover, turning it of 90° (fig. 18).



### Warning

*The opening and possible machine start with door open must only be performed by authorized and technically qualified personnel. Do not leave the machine unattended while it is open.*

Give the key to qualified and authorized personnel only.

Whenever the machine is switched on a test cycle is performed in order to verify the correct position of the moving parts and the presence of water and other products.

## 6.7 Installation



**IMPORTANT:** When switched on, the machine automatically fills the water circuit and the related boilers. For a correct automatic installation in case of a water softener system being used, it is necessary that the latter is completely filled with water and properly relieved of any air bubbles.

### 6.7.1 Cleaning and filling of resin-based water softener



**IMPORTANT:** Before installing the water softener in the machine and using it, clean the resins and fill the water softener. *Then install the water softener already filled with water and cleaned.*

In order to fill in the water softener before installing it on the machine, stick to the following instructions:

- Insert the hose of the bottom tap into a drain container suitable for this purpose.
- open the bottom tap (fig. 19) and the upper plug of the water softener so as to remove the air bubble.

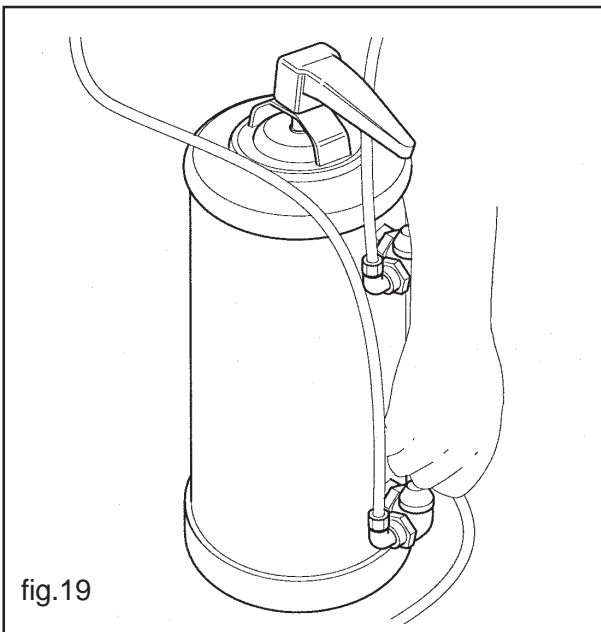

fig.19

- fill up the water softener and let the water flow out of the drain hose until it is clear (fig.20).



fig.20

- close upper plug and turn off the bottom tap

### 6.7.2 Water circuit filling



The machine automatically activates the pump and starts filling the espresso coffee boiler.

#### **IMPORTANT:**

Before powering the machine, thus starting the automatic installation:

1. *Make sure that the water softener is filled with water and the air bubbles removed.*
2. *Load the reachable columns of the cup holder.*

#### **NOTE:**

If the filling of the boiler is not successful, the machine cannot be set into service. A failure message will be shown on the display. Should it be the case, eliminate the cause and reset the error recorded (section 8 'Programming and maintenance menu'), then repeat the automatic installation, switching the machine on once again. After a testing phase on start-up, the machine automatically fills the water circuit of the tray equipped with a float and of the brew group boiler. During this stage, the heating element of the boiler remains automatically off. If the machine detects that the boiler is already filled, it passes to the heating stage.

The sequence of operations will be:

- insert the special key in the machine cover switch
- on start-up of the machine, the filling of the tray equipped with a float starts automatically, while the machine carries out the automatic testing phase.

During testing, the following components start up in the given order:

- the brew group, so as to reach the correct start-up position
- the cup holder, so as to load the first cup column into the releasing device.

During the setting-up phase:

- the coffee boiler and the water tank are filled up
- once the water circuit is filled, the heating phase starts up, thus switching on automatically the boiler heating element.



#### **Recommended solutions**

When the boiler is completely filled, wash the mixer repeatedly in order to remove possible residues from the hydraulic circuits. NB: see section 8 - Programming and Maintenance menu, in order to start test or cleaning brewing.

- After performing these operations, wait a few minutes for the machine to reach service temperature and make beverages available.

### 6.7.3 Cleaning the parts in contact with foodstuffs



Clean all the parts of the vending machine which are in contact with foodstuffs.

- wash your hands carefully.
- prepare a chlorine-based anti-bacterial cleaning solution - they can be purchased at chemists - following the concentrations given on the product instruction label.
- remove all the product containers from the vending machine (fig. 21).



fig.21

- remove their covers, bushes and conveyors (fig. 22). Plunge all parts into the solution, apart from the steel spiral conveyor.



#### Important

Do not plunge the spiral conveyor into the chlorine-based solution; clean it with washing up detergent and rinse carefully.

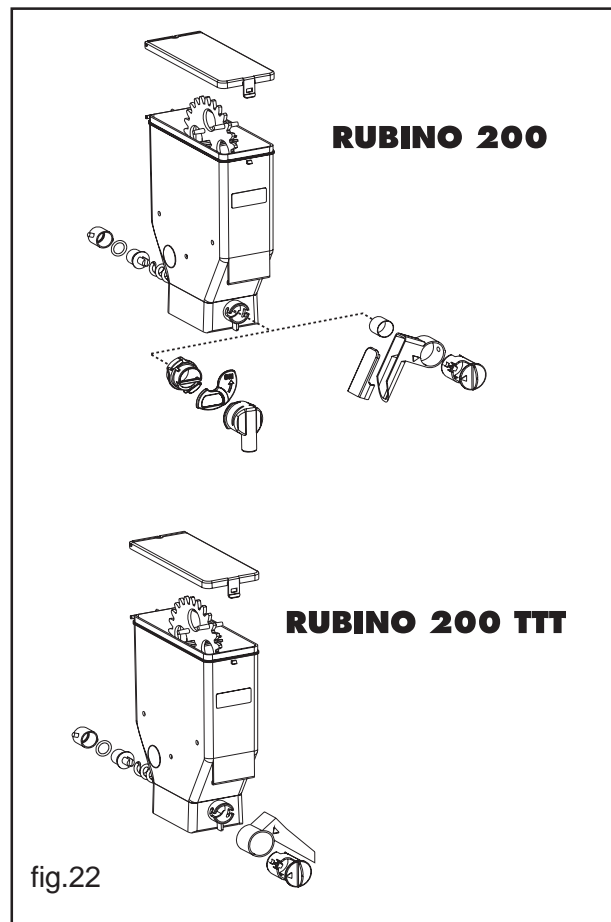

fig.22

- remove all the powder conveyors, water funnels, mixer chambers and fans, silicone hoses and plunge them into the solution (fig.23).



fig.23

- clean also the mixer bases with a cloth soaked in the solution (fig.24)

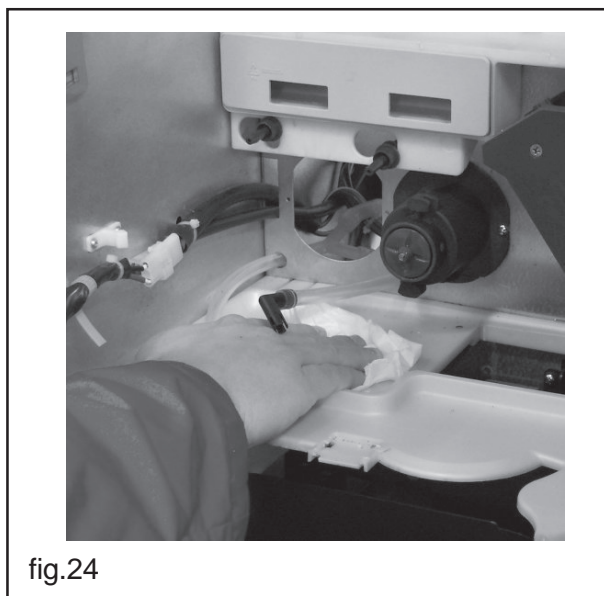

- leave all parts in the solution for the time specified on the packaging
- take all parts off, rinse and wipe carefully, then reassemble them into the vending machine.

### Warning

*For safety's sake, carry out several automatic washings so as to remove possible residues.*

## 6.8 Product loading

### 6.8.1 Container loading

- product containers can be loaded without removing them; however, should it be necessary to remove them, make sure the sliding panel on the product outlet is closed (fig.25). In particular, it is necessary to close the panel located on the hopper before removing the coffee bean container. NB:containers can also be loaded without removing them from their supports

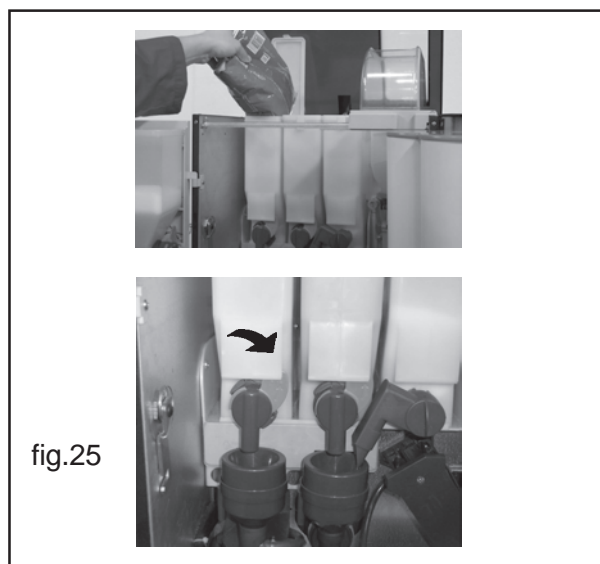

- lift the container cover and fill with the product.
- make sure there is no lump, avoid pressing the product and using too much of it, so as to prevent it from ageing. It is advisable to fill the containers with the exact amount of product necessary for the estimated consumption between two consecutive refillings.

Check each container capacity in the TECHNICAL SPECIFICATIONS section.



### Warning

- *For correct operation of the swivelling conveyor follow the indications below: before starting up, brew the product 3 - 4 times so as to have the duct full (fig.26)*
- *After filling up the sugar container, make sure the bracket is properly repositioned - the jack on the side is supposed to click.*

## 6.8.2 Label insertion

- Selection labels are to be placed in the proper seat, under the transparent plastic plates, following the order set in the Programming and Maintenance Menu.

Perform the operation as follows:

- remove the cup holder (fig. 27)



fig.27

- release the transparent plates from the internal side of the door by pressing the retaining tabs (fig.28)

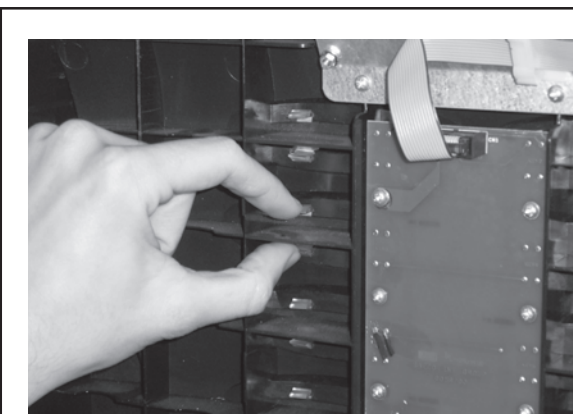

fig.28

- insert product plates on the external side of the door in the desired order (fig. 29)
- apply the transparent plates by snapping them (fig.30)



fig.29/30

- reassemble the cup holder

## 6.8.3 Cup loading

Use only cups suitable for automatic distribution, having 70-71 mm diameter, without pressing them while loading.

### Important

**DO NOT ATTEMPT TO TURN THE COLUMN MANUALLY.**

During installation, with the cup dispenser empty, proceed as follows:

- before powering up the vending machine, load the most easy-to-reach columns (fig. 31).



fig.31

- insert the key into the cover switch (see fig.18) and wait for the column to position itself into the dispensing hole.
- load the other two columns which in the meantime have become reachable (fig.31).
- if you want to fill up the column near the cup conveyor, remove the holder retainer (fig.32 ref. 1) and lean the whole cup dispenser as much as permitted (fig.32 ref. 2), complete the cup column loading and then put back the dispenser and the retainer.

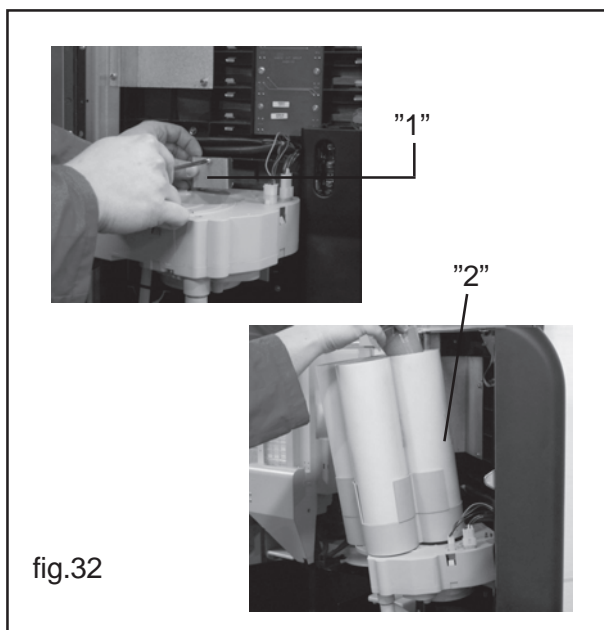

- replace the cover on the container.

#### 6.8.4 Stirrer loading



- Remove the counterbalance bar from the stirrer guides (fig.33)

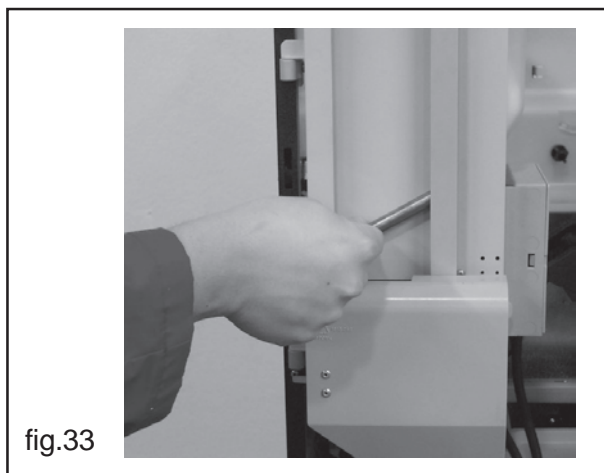

- Introduce stirrers tightened with the band into the column; once they are on the bottom, cut the band and remove it (fig.34)

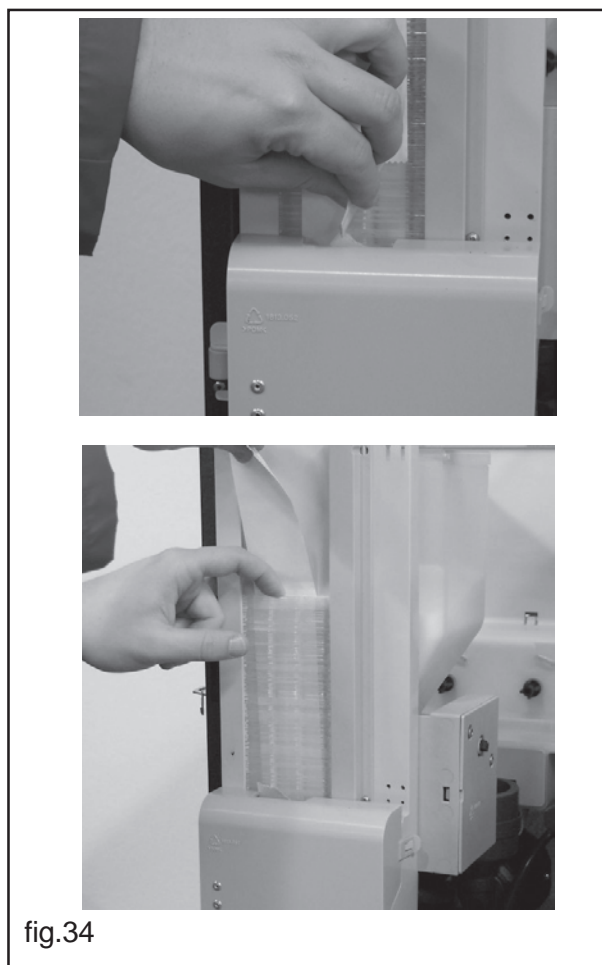

- put back the counterbalance bar (fig.35) after completing the loading

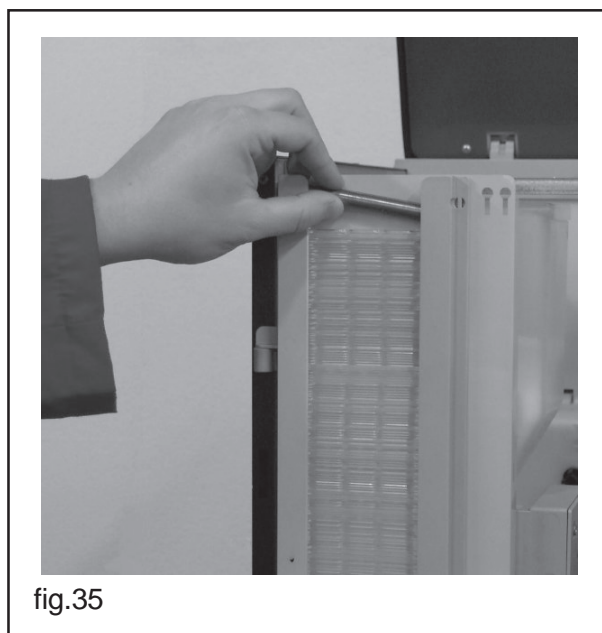

- make sure stirrers have no seams, are not bent and all lay horizontally.

## 7 - PAYMENT SYSTEM INSTALLATION



### 7.1 Payment system installation on the machine



The vending machine has no payment system. The responsibility for possible damages to the machine and other objects and for personal injuries caused by an incorrect installation of the payment system falls on the person who installed the system.

- remove the cup dispenser
- from the internal side of the door, cut the external film following the punched shape which corresponds to the desired cashless payment or coin validation system (fig. 36)

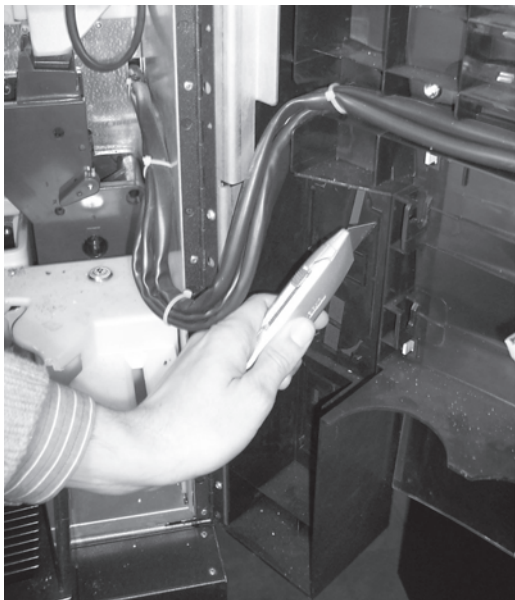

fig.36

- cut away plastic door joints by means of an hacksaw (fig.37)

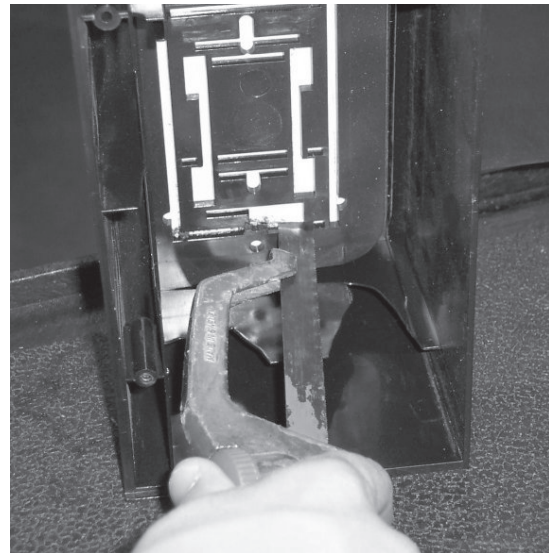

fig.37

- after finishing the whole perimeter, install and secure the payment system
- connect the payment system to the CPU card
- reassemble the cup dispenser

NOTE: a special interface card is required for connecting 12 Vcd coins validation systems to the CPU card.

- Then enter programming so as to choose convenient settings.

See section 8 'PROGRAMMING AND MAINTENANCE MENU' in order to check parameter setting, which should be in line with the system used.



## 7.2 Payment system installation on the base cabinet



The base cabinet has no payment system. The responsibility for possible damages to the machine and other objects and for personal injuries caused by an incorrect installation of the payment system falls on the person who installed the system.

- remove or turn the coiner supporting plate (fig.38, ref.1)
- hook and secure the coiner to the support (fig.38, ref.2)
- reassemble and lock the support to the cabinet door (fig.38, ref.3)

- connect the coiner to the CPU card

NOTE: Executive, MDB and BDV serial systems are connected to the CPU card using a cable and an interface in necessary, both included in the special kit.

- Then enter the programming menu so as to choose convenient settings.

See section 8 'PROGRAMMING AND MAINTENANCE MENU' in order to check parameter setting, which should be in line with the system used.

fig.38, rif.1



fig.38, rif.2



fig.38, rif.3



fig.38

# 8 - PROGRAMMING AND MAINTENANCE MENU



### Important

This chapter illustrates how to set up or modify the machine programming and maintenance parameters.

It should therefore be read carefully, to fully understand the correct sequence of operations to be performed.



### Important

Fig. 39 shows the standard position of keys on the door keypad; to which all the following sections will refer to.

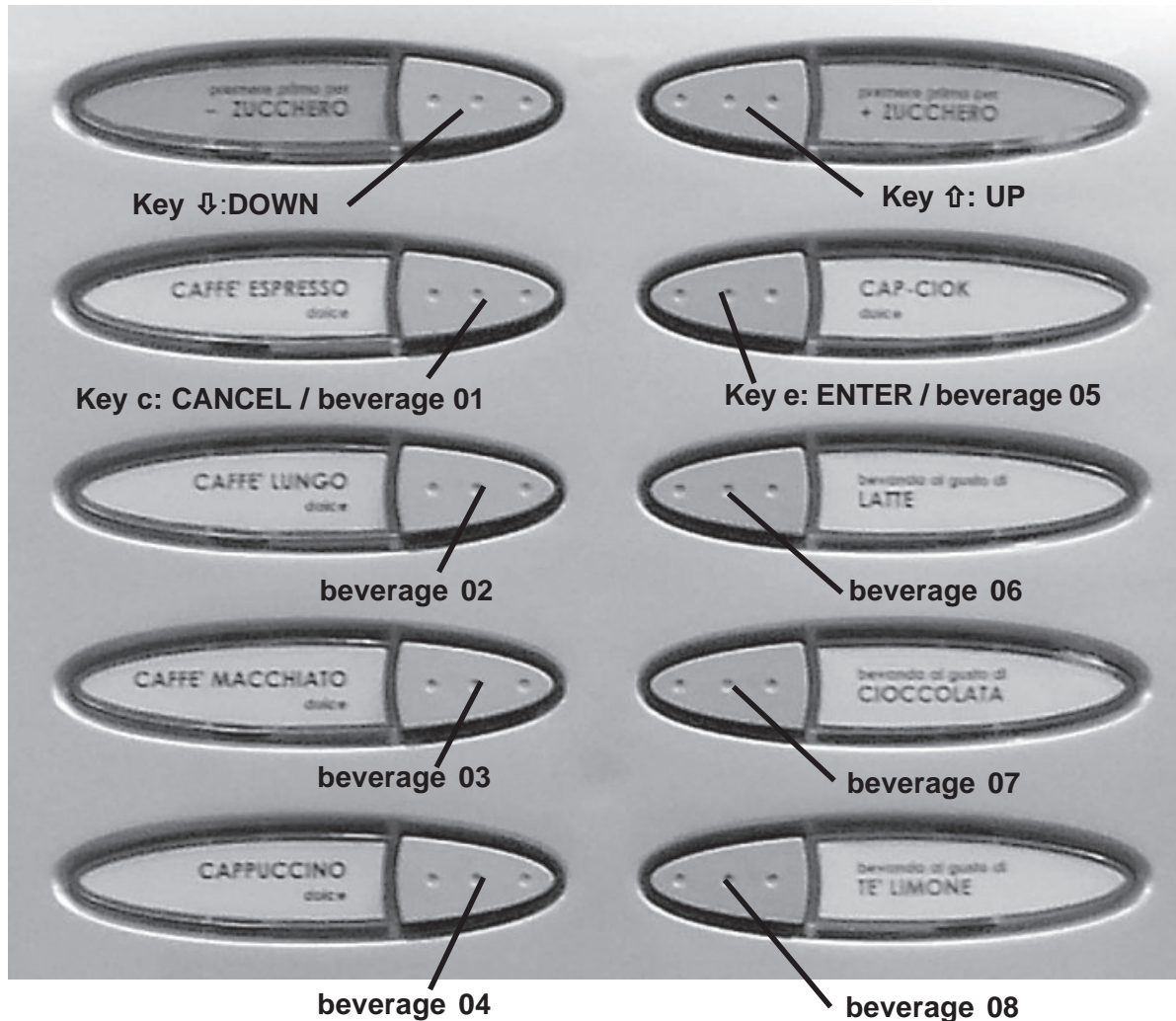

fig.39

## 8.1 Description of programming and maintenance phase keys

To surf inside the menu of the vending machine use the keys described below.

### Key e: ENTER / beverage 05 (fig. 39)

By pressing this key it is possible to access the following level of programming or maintenance. Furthermore it is possible to modify or confirm the values set in the entries of the programming or maintenance menus.

### Key c: CANCEL /beverage 01 (fig. 39)

By pressing this key it is possible to go back to the previous level of the programming or maintenance menu. It is also possible to avoid storing the values of the previously required modification.

### Key ↓: DOWN / - sugar (fig. 39)

By pressing this key it is possible to access the preceding entry inside the same menu level. If used after requesting to modify a datum, it decreases its value of this same datum.

### Key ↑: UP / - sugar (fig. 39)

By pressing this key it is possible to access the following entry inside the same menu level. If used after requesting to modify a datum, it increases the value of this same datum.

## 8.2 Programming menu

The structure of the programming menu is shown in 8.2.2.

8.2.3 describes all the entries in the programming menu.

### 8.2.1 Entering the programming menu

Open the door, insert the key into the safety switch (fig.18) and press key **P1**, located on the CPU card (fig.40, ref. 1) so as to enter the programming menu.

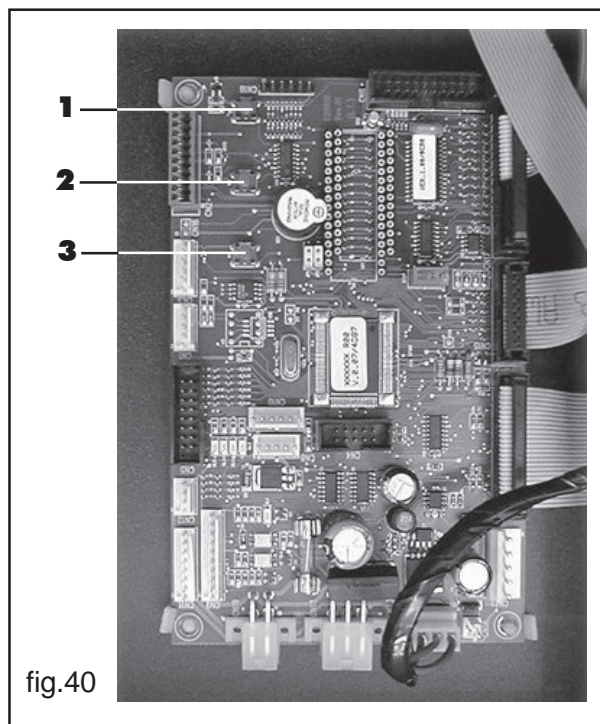

fig.40

If no password has been assigned you enter the programming menu directly.



### Important

If a password to enable the programming menu was assigned to the vending machine, 'PASSWORD 0000' will appear on display with a flashing cursor on the first digit.

Now enter the password using **UP** and **DOWN** keys. Confirm the digit entered pressing the **ENTER** key.

To exit the programming menu and return to the normal operation of the vending machine:

- press key **P1** again;
- remove the key from the safety switch to turn off the vending machine;
- close the door and wait for the self-configuration process to end.

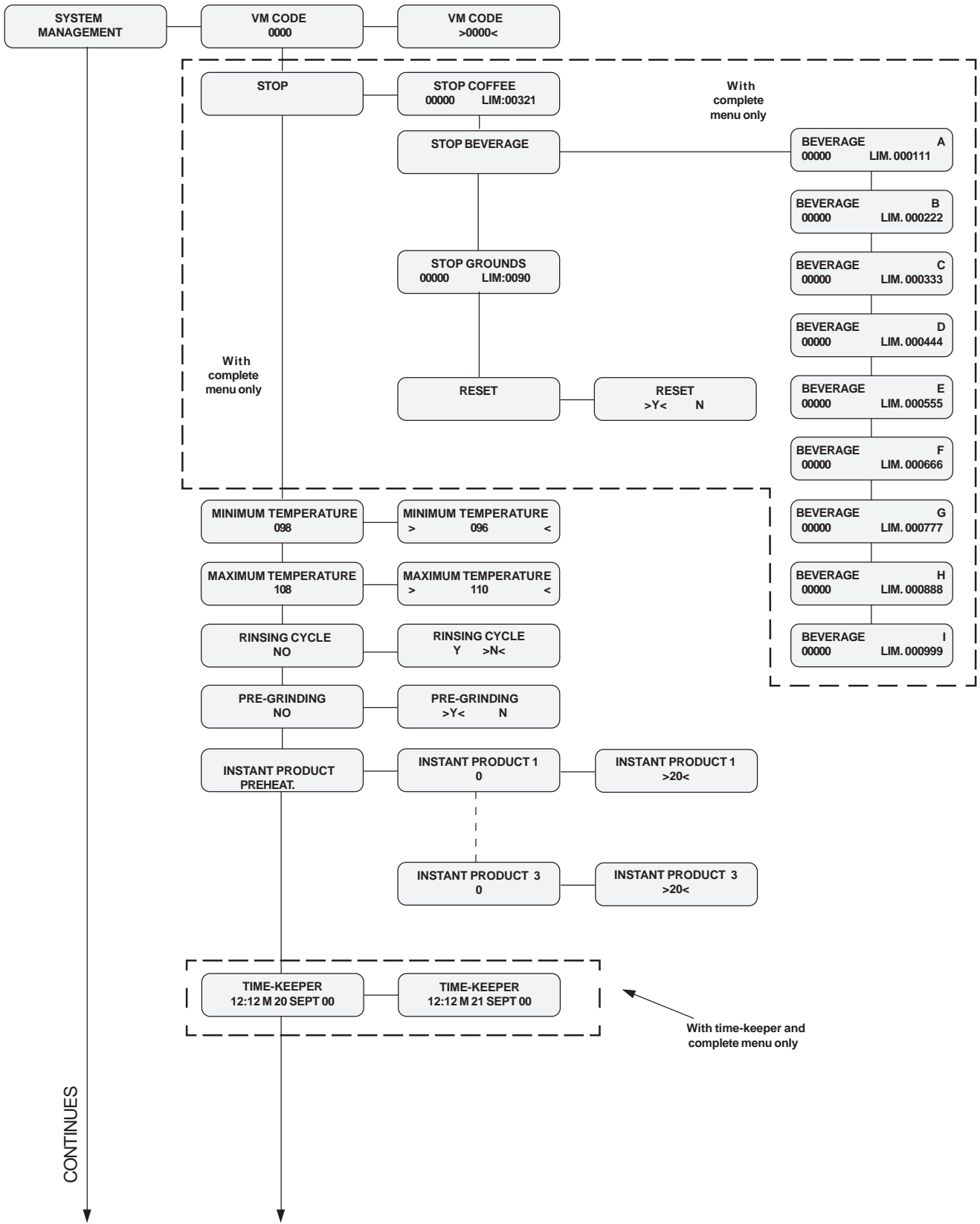

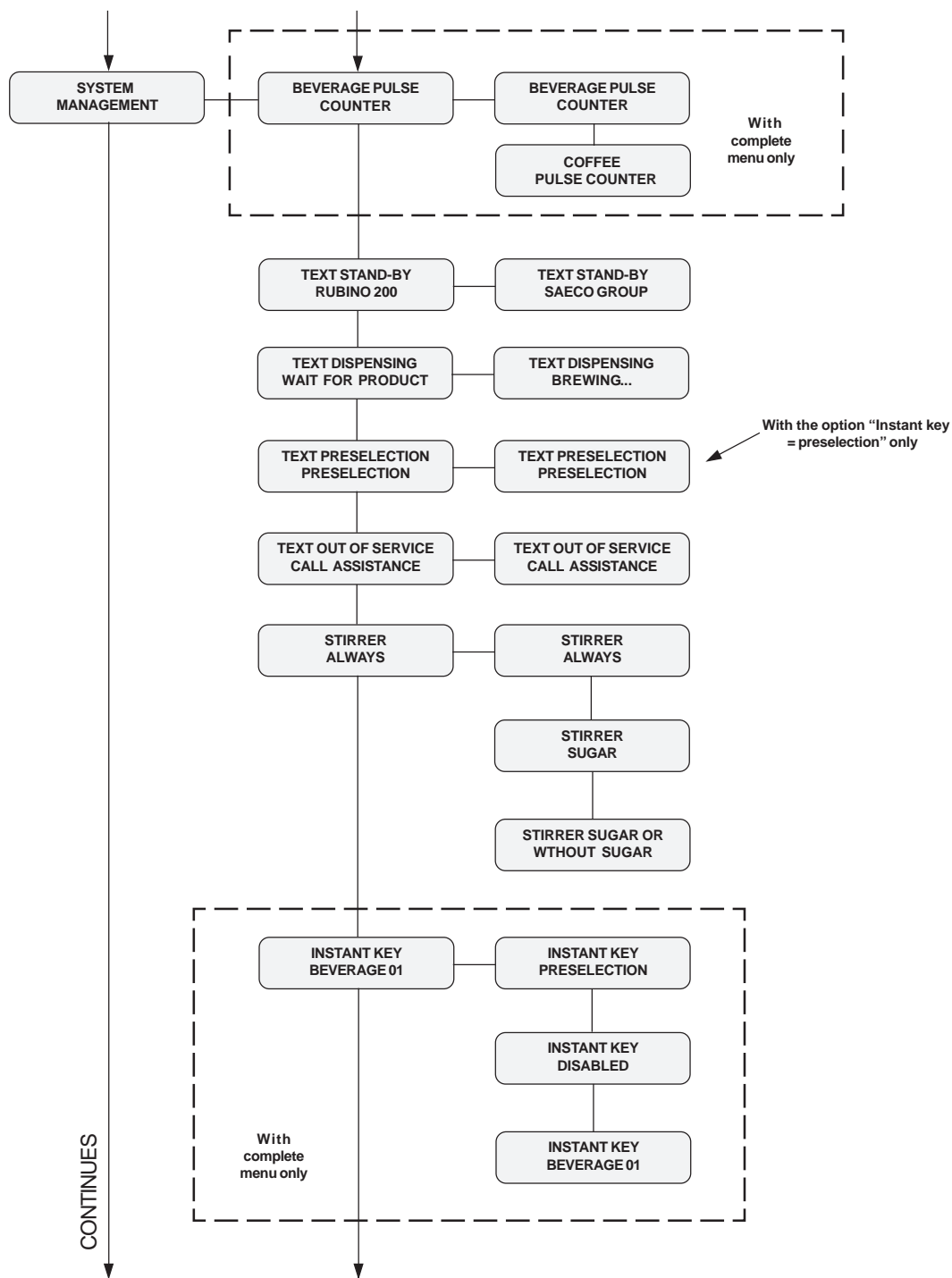

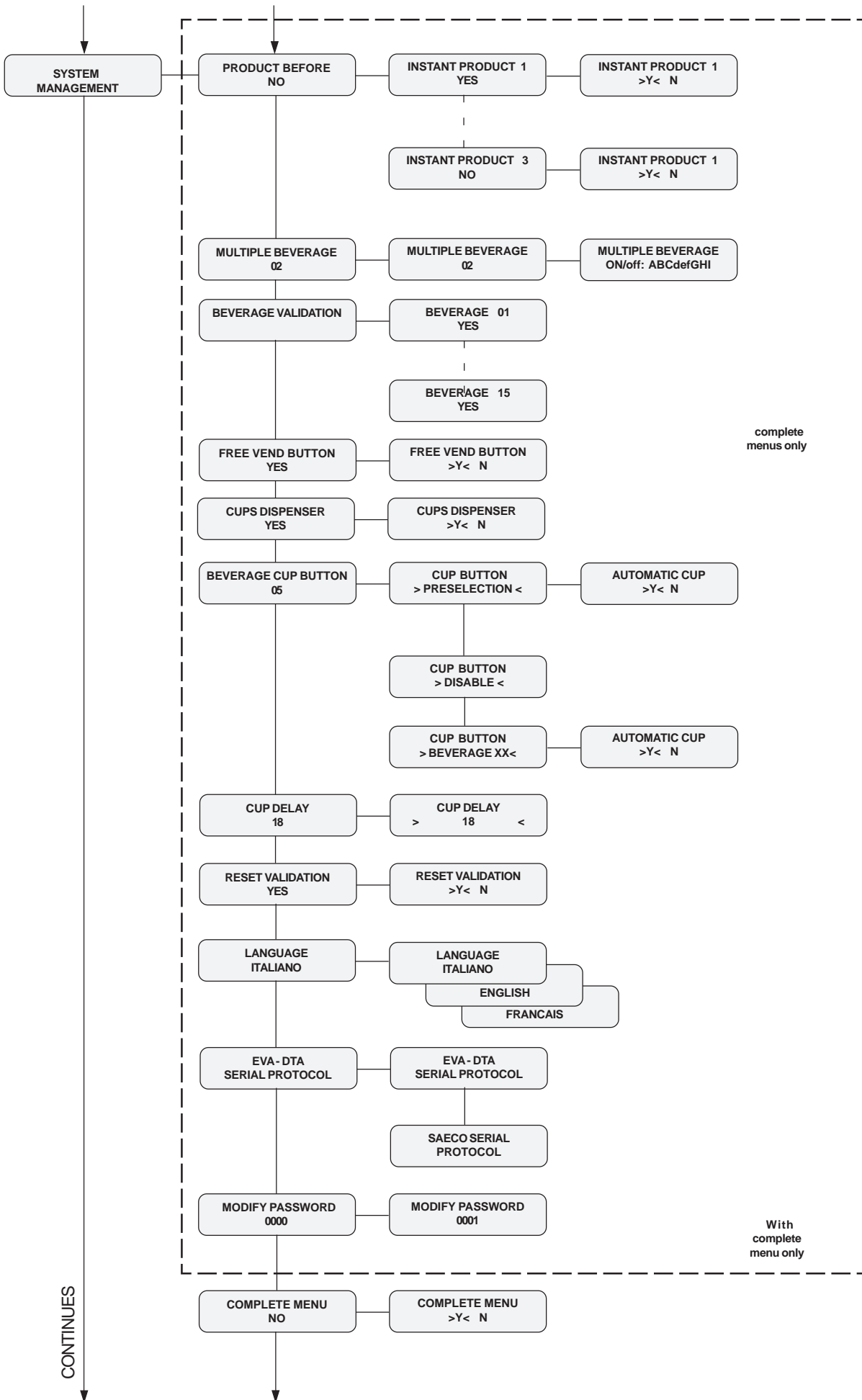

CONTINUES

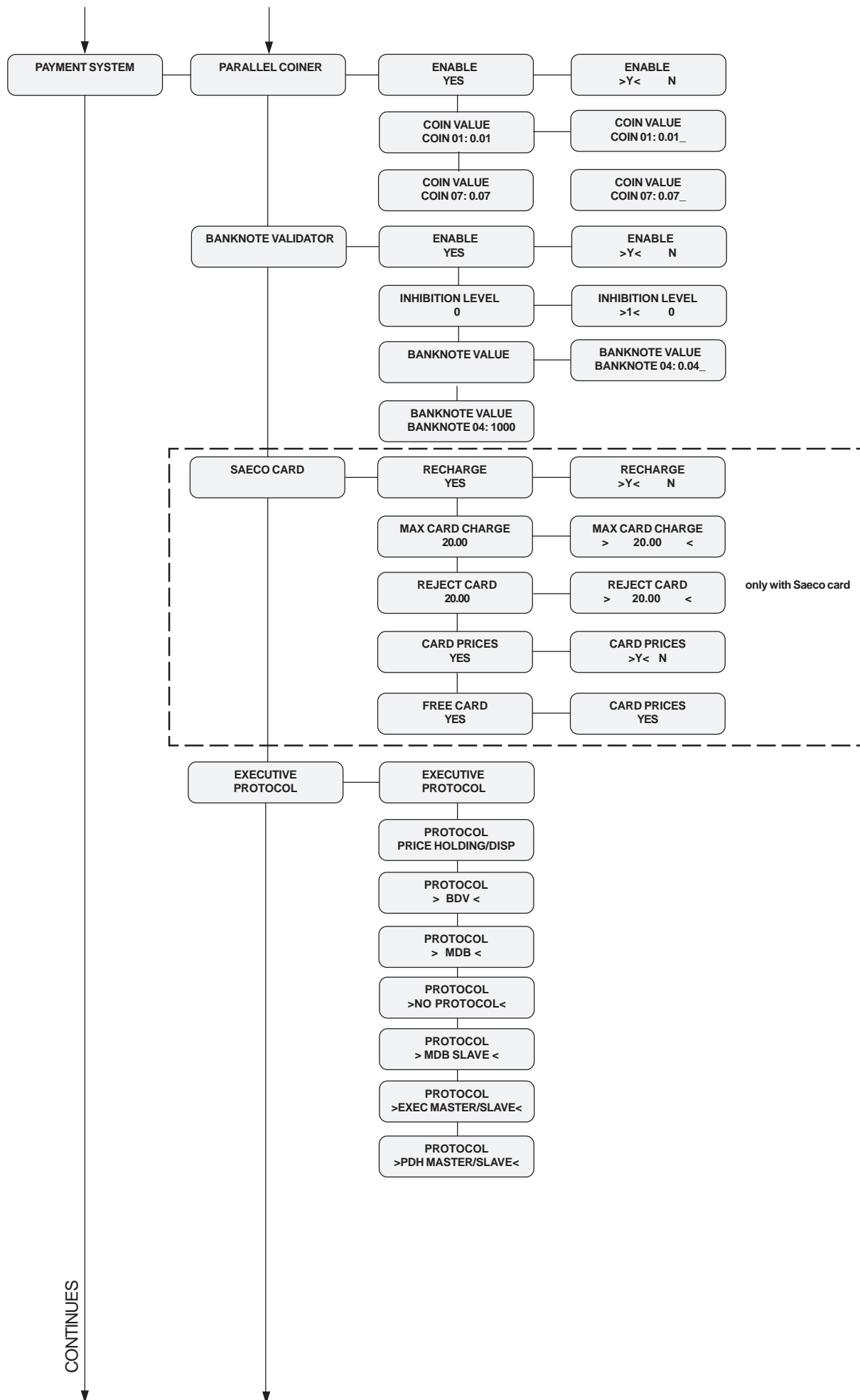

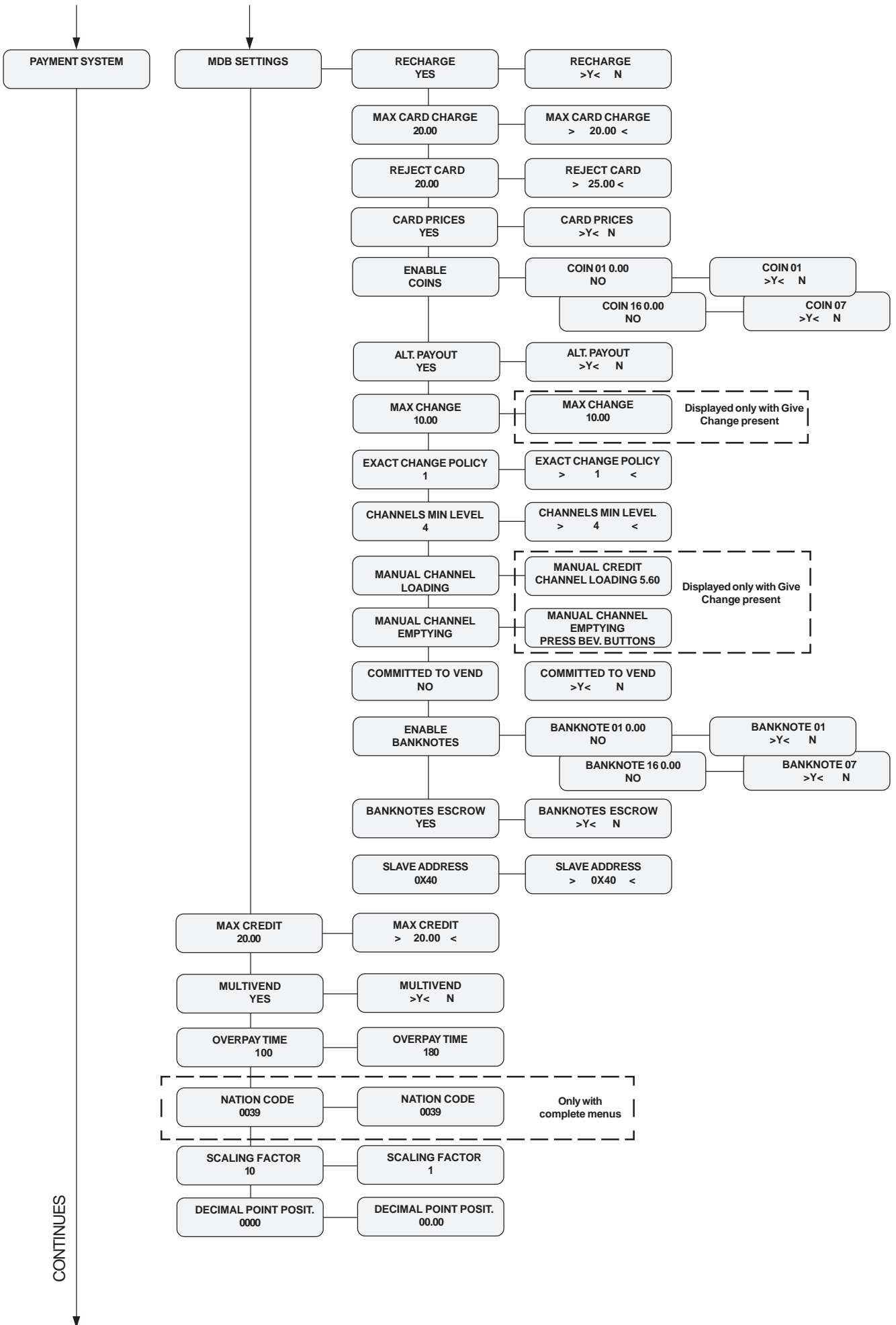



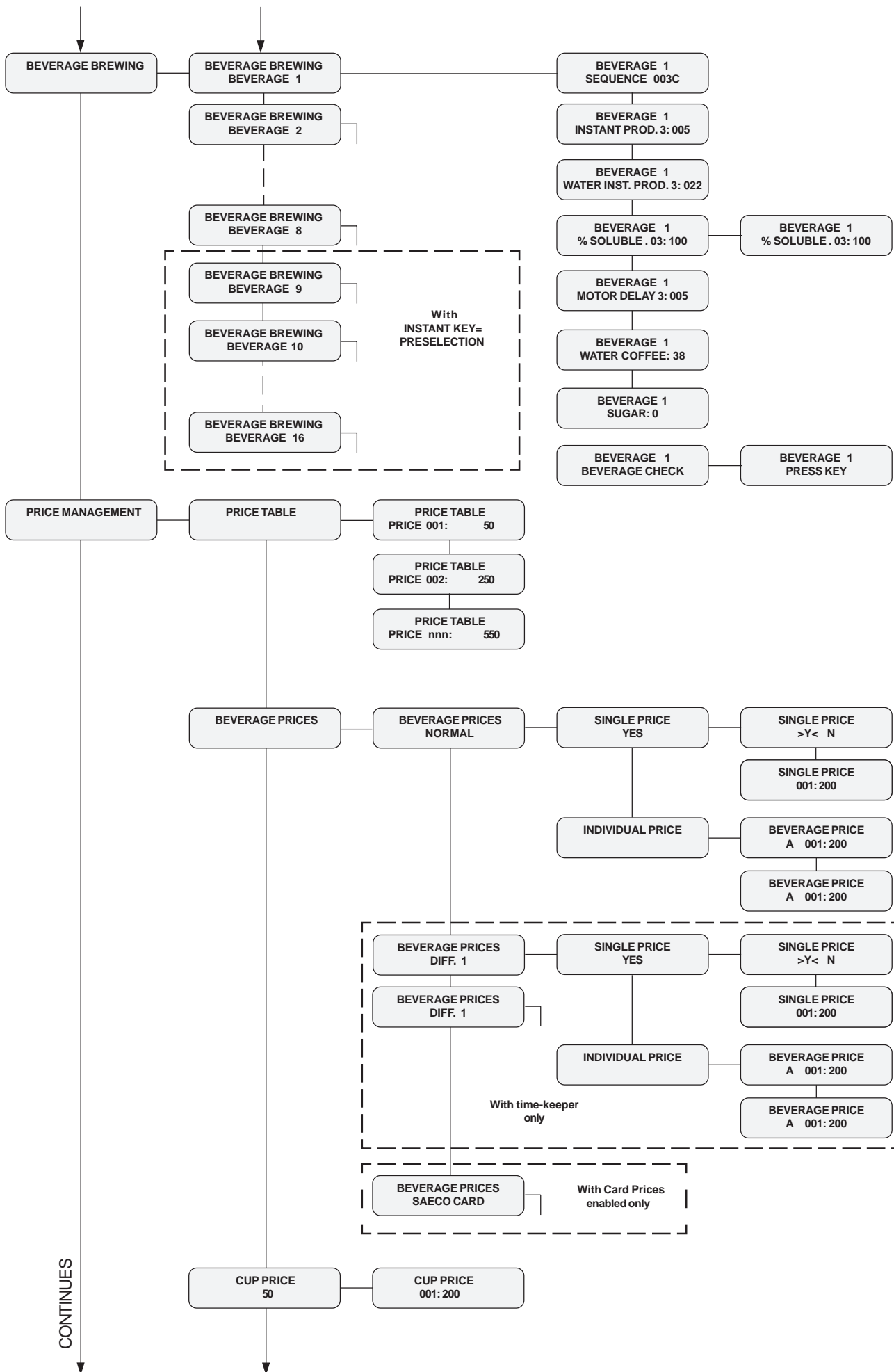

CONTINUES

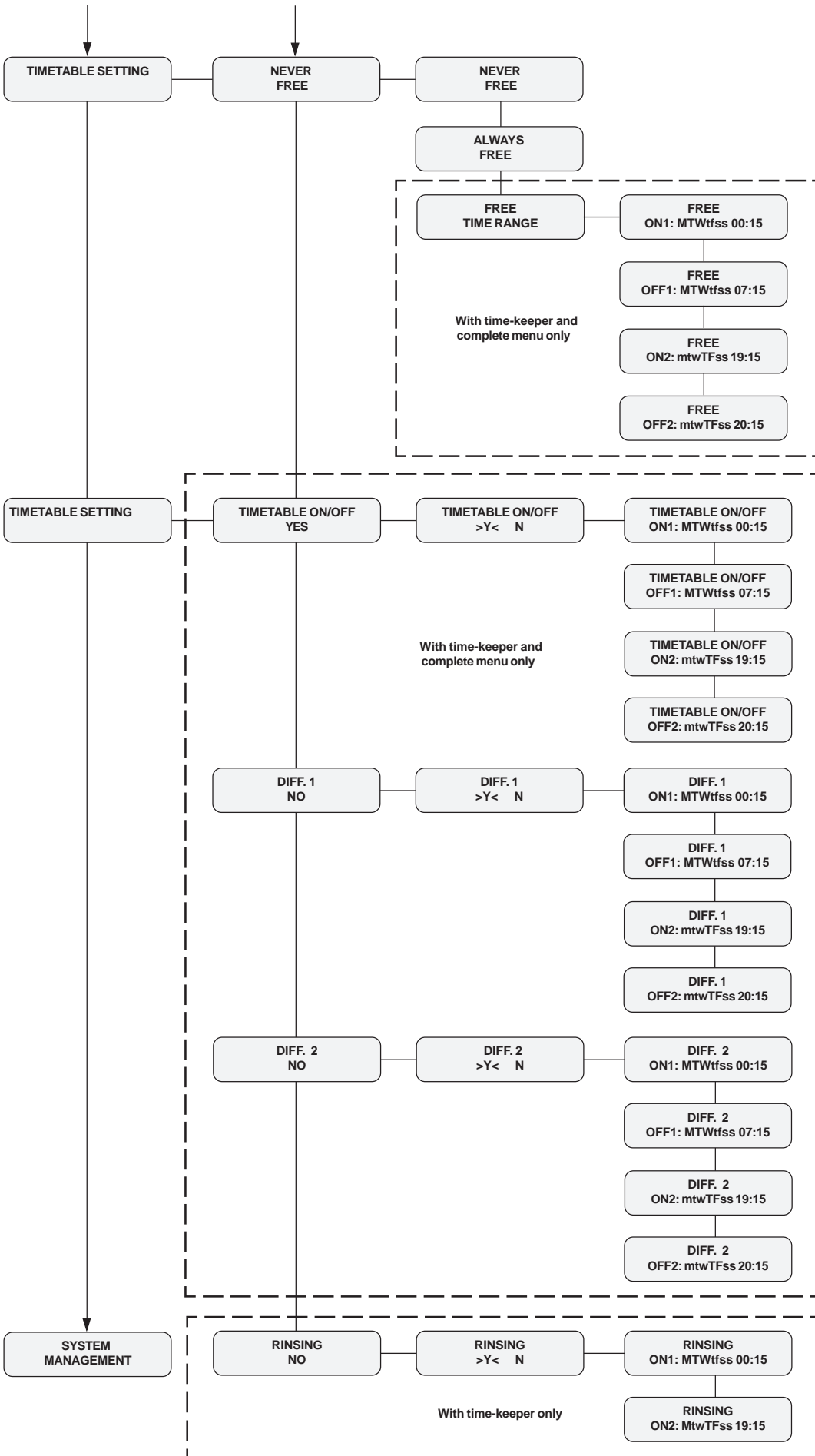

## 8.2.2 Structure of the programming menu

Example of parameter setting To set the PRICE level 3 at 0.3 :

- access the programming menu as indicated in 8.2.1, if the password is not requested, the entry 'SYSTEM MANAGEMENT' will appear;
- scroll the menu items with the **UP** key until 'PRICE MANAGEMENT' is displayed;
- press the **ENTER** key until the following message is displayed: 'PRICE TABLE'
- scroll the menu items with the **UP** key until the following message is displayed: 'PRICE 03'
- press the **ENTER** key (the cursor on the value to be modified will flash);
- increase or reduce the value with the **UP** and/ or **DOWN** keys until reaching 0.3 and press the **ENTER** key to confirm the value desired the cursor disappears.

## 8.2.3 Functions of the programming menu

### SYSTEM MANAGEMENT

The entries of the SYSTEM MANAGEMENT are:

#### - Vending Machine Code

It allows you to assign an identification code for the vending machine.

#### - Stops

It allows you to set the maximum amount of beverage or coffee. Once reached the maximum amount, the vending machine stops the brewing of relevant beverages.

The first digit on the left ('00000') refers to the quantity of the product dispensed from the last 'RESET' (partial counters reset).

The left hand digit, preceded by 'LIM', shows the maximum dispensable quantity (changeable value).

#### - Stop coffee

It allows to set the maximum number of coffee cups to be brewed before the stop.

#### - Stop beverage

It allows you to set the maximum number of individual beverages to be brewed before the stop.

#### - Stop grounds

It allows you to set the maximum number of coffee cups to be brewed, corresponding to maximum dump box capacity. Once reached the set quantity, coffee-based beverages dispensing is stopped. The display shows the blinking message 'REMOVE DUMPS' before brewing the last ten coffees.



#### Important

This stop can be reset by removing the dump box for at least 5 sec.



#### Recommended solutions

It is advisable to set a max. of 100 coffees when using the dump box supplied with the machine



#### Important

Do not set any stop value if you are using the machine together with the supporting cabinet, which is equipped with its own dump box which is not controlled electronically

#### - Reset

It allows you to reset partial counters of stop functions.

#### - Minimum temperature

It allows you to set the temperature that the vending machine keeps for a few minutes after a beverage has been brewed. Set value is not expressed in centigrade.

### - **Maximum temperature**

It allows you to assign the temperature to which the vending machine is brought after a certain time from the last dispensing, so that the natural lowering of the temperature of the hydraulic circuits can be compensated. Set value is not expressed in centigrade.

### - **Wash cycle**

It enables starting the mixing bowls automatic wash.

The automatic wash is performed as follows: the first wash take place 10 minutes after the 'machine ready' status; if necessary, other washes occur 7 hours after the last brewing.



### **Recommended solutions**

Automatic washes should be set only if the machine is used together with the cabinet, which is equipped with a large discharge fluid tank.

### - **Pre-grinding**

It validates instant pre-grinding of the coffee dose

### - **Instant product preheating**

It allows enabling preheating only for selected products.

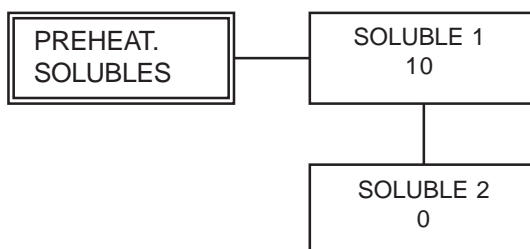

By validating this function the vending machine execute a preliminary water brewing through the circuit corresponding to the selected instant product. The user can choose the instant products for which to validate the prewash by setting a value >0 for the water to be used for prewashing.

Example: the settings shown in the figure validate preheating for instant product 1 with 10 units of water and do not validate preheating for instant product 2.

Preheating for an instant product is executed if: at least 3 minutes have passed since the mixing bowl was used; the amount of water for the instant product is < 50 units.



### **Recommended solutions**

Instant product preheating should be set only if the machine is used together with the cabinet, which is equipped with a large discharge fluid tank.

- **Clock** (shown only if the clock module has been installed)

It allows you to set current hours, minutes, day of the week, day of the month, month and year.

- **Coffee / beverage pulse counter** - shown only if the 'complete menus' option is validated  
The electromechanical pulse counter 24V dc (option) allows to choose whether to count only coffee or all the beverages brewed.

- **Text: Stand-by**

It allows you to enter the message displayed when the vending machine is in normal operating mode.

- **Text: Dispensing**

It allows you to set the message displayed when the vending machine is brewing a product.

- **Text: Out of Service**

It allows you to set the message displayed when the vending machine stops for a failure.

- **Text: Preselection**

It allows you to set the message displayed when the preselection mode is activated.

### - **Stirrer**

It allows you to select the stirrer dispensing mode  
STIRRER ALWAYS: the stirrer is dispensed anyway;

STIRRER SUGAR: the stirrer is dispensed only if the beverage is served with sugar;

STIRRER SUGAR or WITHOUT SUGAR: the stirrer is dispensed for all the beverages which should be served with sugar, although the user demands the beverage without it.

### - **key Instant**

While the machine is normal operation mode, it allows to validate the key **beverage 01** (Fig.39) as:

1 - '**Preselection**' in this case, by pressing the key the vending machine displays the preselection message - 'preselection' by default - and makes another beverage group available (from 09 to 15). The beverages or recipes that the vending machine can now prepare and brew are 14.

Example: after pressing the key "beverage 01" PRESELECTION is activated and by pressing the key "beverage 02' the vending machine brews the beverage/receipt 09 instead of the beverage 2.



### **Important**

With this configuration it is necessary to set the new beverage/receipt group available - see the BEVERAGE PREPARATION menu.

2 - '**Beverage 01**': in this case, by pressing this key the beverage/receipt 01 is brewed.

3 - '**Disabled**': in this case, by pressing this key no beverage will be brewed.

### - **Product before**

It allows selecting the instant product for which you wish to enable powder dispensing before water dispensing. This brewing cycle will be carried out only when the quantity of powder to be brewed does not exceed 22.

### - **Multiple beverage**

It allows to set beverage multiple dispensing.

It allows to select which beverages will be enabled for multiple dispensing and the number of dispensing.

The upper line will remain the same for all following operations, while the lower one will show the number of consecutive beverages. It is possible to set a value between 2 and 8.

### - **Beverage validation**

It allows to enable or disable the beverage keys.

The combination KEY - BEVERAGE NUMBER is indicated in fig.41.

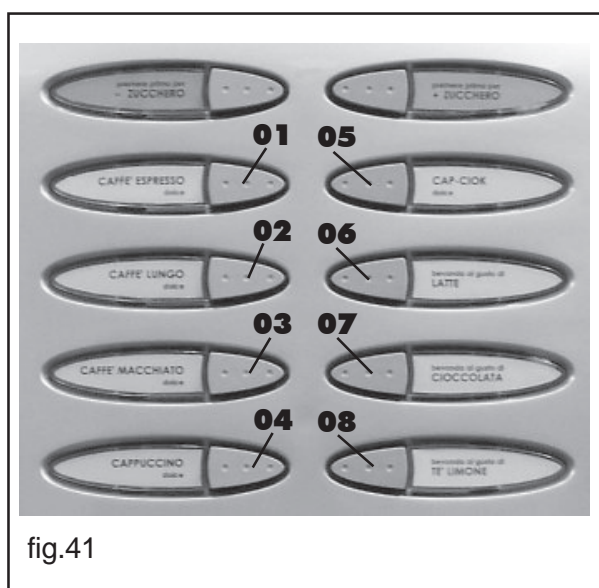

fig.41

By pressing a disabled key during operation, the message "NOT AVAILABLE" will be displayed.

### - **Free vend button**

It allows to enable key **P3** (Fig. 40, ref. 3) of the CPU card to the free dispensing of a product during the normal operating phase.

### - **Cups dispenser**

It allows you to set the use the vending machine without cup, stirrers and sugar. To effect this' it will be had to plan No. The vending machine won't introduce conditions of error tied to such operations (error 06: Cup bracket not in position).

#### - **Cup key**

It allows to enable or disable the key 'beverage 05' (fig. 39) as:

1 - **'No cup'**: By pressing the No-CUP key before choosing a beverage allows to have it brewed without the cup.

After pushing the preselection key, the user has 8 seconds to select the desired product. After this time the preselection is cancelled.

If CUPS DISPENSER are planned on No, the voice PRESELECTION won't have shown.

2 - **'Beverage 05'**: in this case, by pressing this key the beverage 05 is brewed.

3 - **'Disabled'**: in this case, by pressing this key no beverage will be brewed.

#### - **Cup delay (only with complete menus ON)**

While loading cups, the cup holder of the vending machine turns until the new cup column has activated the cup detection microswitch. This item enables to set the delay between the activation of the cup detection microswitch and the holder motor stop. Adjust this value according to the cup type used on the vending machine. The default value is 18.

#### - **Reset validation**

It allows to 'RESET' the data in the maintenance menu (STATISTICS).

#### - **Language**

It allows to select the language to be used by the machine.

#### - **Serial protocol**

It allows selecting the protocol to be used by the vending machine when interacting with the serial interface (optional).

#### - **Modify password**

It allows to set a password or to modify the set one. The password consists of a number between 0001 and 65536. The 0000 value (default value) means no password. To set the password, press the **UP** and **DOWN** keys and confirm using the **ENTER** key.

#### - **Complete menu**

It allows to choose whether the entries of the programming menu should be shown entirely or only partially. The least frequently used entries are highlighted by a frame outlined at 8.2.2 and can be shown only if in the data 'Y' is set in this function.

## PAYMENT SYSTEMS

The entries of the PAYMENT SYSTEM are:

### - **Parallel coiner**

It allows the enabling of the parameters of the parallel coiner, the mechanical coiner, the cancelling machine and the choice of the values to be assigned to the single money channels.

### - **Enable**

By setting:

- “Y”, the management of the parallel coiner, the mechanical coiner and the cancelling machine is enabled.
- “N”, any parallel coiner connected to the vending machine is disabled.

### - **Coin value**

It enables to set the value of the coins transferred to the vending machine from the parallel coiner, the mechanical coiner and the cancelling machine.

The following table shows the channel / payment system combinations.

Channel	Payment system
1	Parallel coiner
2	parallel coiner
3	Parallel coiner
4	Parallel coiner
5	Parallel coiner
6	Parallel coiner/mechanical coiner
7	Canceling machine/mechanical coiner

### - **Banknote Validator**

It enables the parameters of the parallel banknote validator and the choice of values to be assigned to single banknote channels.

### - **Enable**

By setting:

- “Y”, the management of the parallel banknote validator is enabled.
- “N”, any parallel banknote validator connected to the vending machine is disabled.

### - **Inhibition Level**

It allows the setting of the active level of the banknote validator’s inhibition level.

### - **Banknote Value**

It enables to set the value of the banknotes transferred to the vending machine from the parallel validator.

- **Saeco Card**

If the Saeco card module (automatically detected by the VM) is present, the following entries are added to the PAYMENT SYSTEM programming menu:

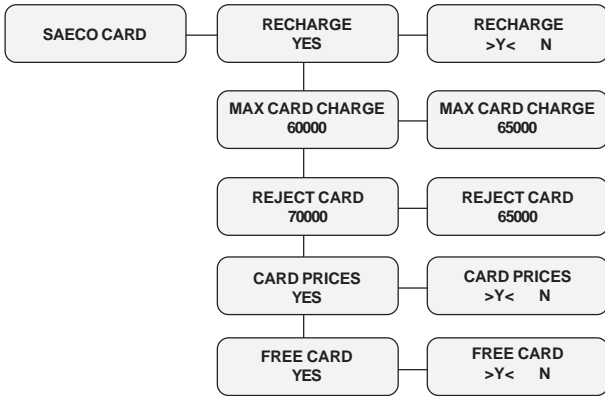

Entry description:

• **Recharge:**

It allows disabling or enabling the possibility of performing any Saeco card recharge operation. By setting RECHARGE = NO the vending machine will only deduct the cost from Saeco cards.

• **Max card recharge**

It enables to set the maximum credit level, beyond which all recharge operations (if enabled) are ineffective. By setting MAX RECHARGE = 20.00, the credit on the vending machine will be transferred to the card if the sum of the credit on the vending machine and on the card does not exceed 20.00.

• **Reject card**

It enables to set the maximum credit level, beyond which the card is rejected by the system. By setting REJECT CARD = 25.00, the vending machine will reject all cards with a credit which exceeds this amount. If this card is detected, the display will not show the credit but a “ —— ” message will be displayed and no sale will be carried out.

• **Card prices**

This function enables the application of differentiated prices if the card is used for payment. By setting CARD PRICES = YES a new menu entry will appear in PRICE MANAGEMENT, enabling setting the price level to be applied to the product (beverage or snack) if payment is made by card.

• **Free Card**

It allows enabling or disabling the use of free service cards. By setting FREE CARD = NO, free service cards will not be accepted by the vending machine.

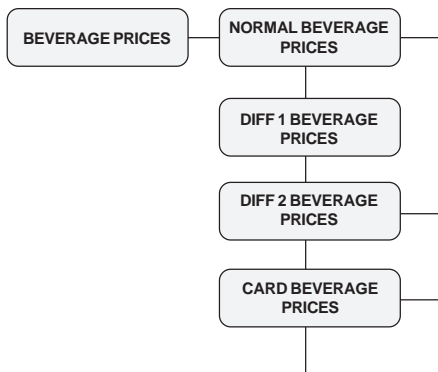



### - **Protocol**

It enables the selection of the protocol used by the vending machine to dialogue with the payment system installed on it:

- **EXECUTIVE Protocol;**
- **PRICE HOLDING (ECS) Protocol;**
- **BDV Protocol;**
- **MBD Protocol;**
- **NO PROTOCOL (no serial protocol);**
- **MDB SLAVE (the vending machine operates as slave to another vending machine);**
- **Master / Slave executive (the vending machine operates as master for another vending machine).**
- **PDH Master / Slave (the vending machine operates as master for another vending machine) .**

The **NO PROTOCOL** setting shall be used when the VM is not equipped with a payment system operating with one of the protocols provided in the other settings: **EXECUTIVE, PRICE HOLDING, BDV, MBD** or **MDB SLAVE**.

This setting is necessary since the VM continuously checks for dialogue with the provided payment system. If the VM detects no dialogue, it signals this fault on the display through the message "NO LINK". This signal cannot be considered an error condition.

### - **MDB settings**

It enables access to particular functions of the MDB protocol.

#### • Recharge

It allows disabling or enabling the possibility of performing any MDB card recharge operation. By setting RECHARGE = NO the vending machine will only deduct the cost from MDB cards.

#### • Max card charge

It enables to set the maximum credit level, beyond which all recharge operations (if enabled) are ineffective. By setting MAX RECHARGE = 20.00, the credit on the vending machine will be transferred to the card if the sum of the credit on the vending machine and on the card does not exceed 20.00.

#### • Reject card

It enables to set the maximum credit level, beyond which the card is rejected by the system.

By setting REJECT CARD = 25.00, the vending machine will reject all cards with a credit which exceeds this amount. If this card is detected, the display will not show the credit but a " —— " message will be displayed and no sale will be carried out.

#### • Card prices

This function enables the application of differentiated prices if the card is used for payment. By setting CARD PRICES = YES a new menu entry will appear in PRICE MANAGEMENT, enabling setting the price level to be applied to the product (beverage or snack) if payment is made by card.

#### • Enable coins

It enables the selection of which coins will be accepted by the change-giving coiner. By setting 'Y' a specific coin will be accepted. On the contrary, the 'N' setting prevents the change-giving coiner from accepting a particular coin. Coins beneath the vending machine scale factor are always disabled and display the 'N' setting.

#### • Alt. payout

It enables / disables the use of Alternative Payout for the level 3 MDB change-giving coiner. By setting Yes, the change-giving coiner is called on to dispense change. Change is limited to 255 times the scaling factor of the change-giving coiner (typically 12.75 for the Euro area - with scaling factor of 5). By setting No, change is given by exploiting the vending machine's algorithm. Max. change is 60000 units (typically 600 for the Euro area).

#### • Maximum change

It enables setting of the maximum change which can be dispensed by the change-giving coiner. Default = 10.00.

#### • Exact change policy

In MDB change-giving coiners, the condition of **no change available** can be selected within the following table:

Key:

**L** = channel with the lowest coin value below the minimum level

**M** = channel with the medium-low coin value below the minimum level

**HL** = channel with the medium-high coin value below the minimum level

**HH** = channel with the highest coin value below the minimum level

No.	Description
0	L or M or HL or HH
1	L or M
2	HL or HH
3	L or HH
4	L
5	M
6	HL
7	L and HH
8	HL and HH
9	L and M
10	L and M and HL and HH
11	L and HL or L and HH
12	L or HL and HH
13	HH
14	L and M and HL
15	Never (change always available)

#### Notes

Even if the **no change available** message is displayed, the vending machine continues to give change as long as coins are present in the channels. The minimum level (the same for all channels) can be set on a special menu item.

- Channel minimum level

It enables setting of the minimum number of coins in the channels. Default = 4.

- Manual channel loading

It allows the change-giving coiner channels to be filled manually. Press Esc to exit the channel loading mode.

- Manual channel emptying

It allows the change-giving coiner channels to be emptied by pressing the beverage selection buttons.

- Committed to vend

By setting 'N', the credit inserted can be returned even if no sale has been made. This function may be useful, for example, for changing banknotes into coins. By setting 'Y', the credit inserted can be returned as change only after the sale has been completed. Default = YES.

- Enable banknotes

It enables selection of which banknotes will be accepted by the MDB banknote reader. By setting 'Y' a specific banknote will be accepted. On the contrary, the 'N' setting prevents the banknote reader from accepting a specific banknote. Default = All enabled.

- Banknotes escrow

By setting 'Y', an inserted banknote is stored in the escrow position (if the banknote reader supports it); this function is supported by the banknote reader. In this way, if the sale fails or the card system fails to charge, the banknote will be returned. By setting 'N', any inserted banknote goes to the banknote reader's stacker, so that the banknotes cannot be returned. Default = No.

- Slave address

When the vending machine is in Master mode, this menu enables setting of the address of any slave connected vending machine. If the vending machine is in Slave mode, it enables setting of its address. Possible addresses are 0x40, 0x48 and 0x50. Default = 0x40.

- **Maximum credit**

It allows the user to set the maximum credit which can be accepted by the vending machine. Once this limit has been reached, the payment systems are disabled so that no more credit can be accepted. Default = 20.00.

- **Multivend**

It enables the user to use any residual credit to purchase other beverages. By setting "N" (no), the vending machine will store residual credit.

- **Overpay Time**

It establishes the maximum time (expressed in seconds) beyond which the vending machine collects the displayed residual credit. The time is adjustable at intervals of 10 seconds. Setting "000" the function is disabled.

- **Nation code (displayed only with "Complete menus" option enabled)**

It enables to set the country code, which corresponds to the international dialling code (E.g. ITALY = 0039).

- **Scale factor**

It enables to set the number of fixed zeros of the credit.

- **Point position**

It enables to set the position of the decimal point of the credit.

## RUBINO 200

### BEVERAGE BREWING

The vending machine can brew 8 beverages by direct selection or up to 14 beverages, 7 of which in preselection mode. Each beverage can be prepared using coffee beans and/or instant products. The technician can choose the desired products for the receipt (max 4) and the order of use. Each component is identified by a number or a digit (fig. 42a).

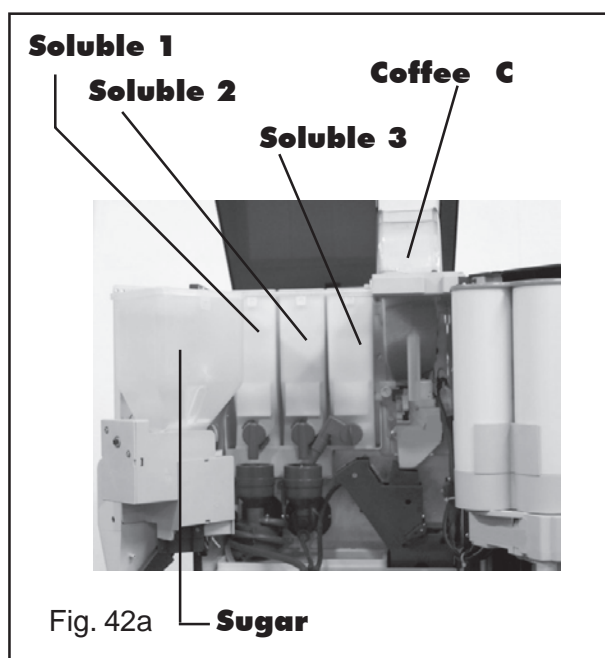

#### - Sequence:

Is the order in which the products making up the beverage are brewed.

'0' means no product. Thus, the combination of digits 'C300' or 'C030' or '0C30', means that product 3 and coffee beans will always be dispensed.

Based on the sequence, the settings of the parameters relevant to the products making up the beverage will be requested.

## RUBINO 200 T.T.T.

### BEVERAGE BREWING

The vending machine can brew 8 beverages by direct selection or up to 14 beverages, 7 of which in preselection mode. Each beverage can be prepared using coffee beans and/or instant products. The technician can choose the desired products for the receipt (max 4) and the order of use. Each component is identified by a number or a digit (fig. 42b).

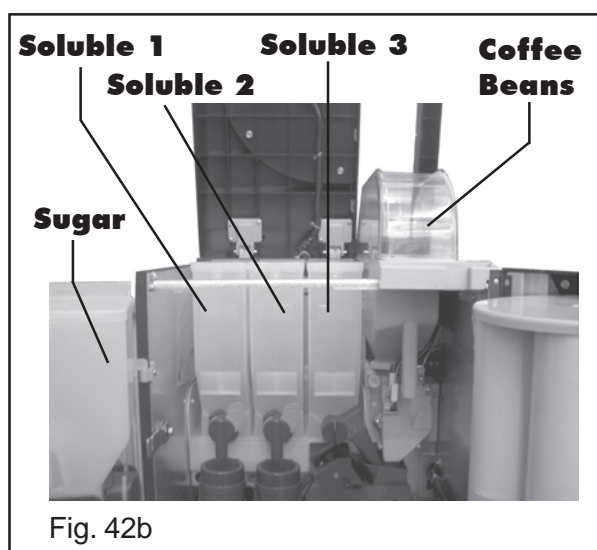

#### - Sequence:

Is the order in which the products making up the beverage are brewed.

Available products are: 1,2,C,B,P,F

The table explains the meaning of each component:

Comp.	Result
1.....	Dr ink made with soluble 1
2.....	Dr ink made with soluble 2
C.....	Espresso coffee made with freshly milled coffee beans
B.....	Fresh brew coffee made with freshly milled coffee beans
F.....	Fresh brew coffee made with premilled coffee (captured from soluble container 3)
P.....	Espresso coffee made with premilled coffee (captured from soluble container 3)

"0" means no product. Thus, the combination of digits "C200" or "C020" or "0C20", means that product 2 and coffee beans will always be dispensed. Based on the sequence, the settings of the parameters relevant to the products making up the beverage will be requested.

**- Instant product:**

It defines the quantity of instant product to be dispensed.

Example:



'005' indicates that 5 units of instant product 3 will be used.

The quantity of instant product can be adjusted from '0' to '250' with steps of 1.

**- Instant water:**

It defines the amount of water to be mixed with powder instant product.

Example:

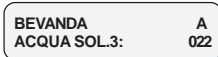

'3' indicates that water will be mixed with instant product 3. '022' indicates that 22 units of water will be brewed with the instant product.

The amount of water can be adjusted from '0' to '500' with steps of 2.

Coffee beans C



**Important**

In case the sequence includes more instant products, the sequence 'INSTANT - WATER' will appear again.

If parameter programming concerning the instant product ('INSTANT - WATER') is such to extend powder brewing beyond water brewing, the vending machine stops powder dosing as to avoid an insufficient mixer rinsing and emits a beep. Check again the parameters set, in order to obtain a correct dispensing. Powder dispensing must end a few instants before the water dispensing so as to allow a good mixer rinsing.

**- % Soluble**

This defines the speed at which the instant powder and water are brewed (see chart).

Brewing speed of instant powder and hot water is adjustable from "10" to "120" in steps of 10.

By setting a value of "10", the pump works at the maximum capacity, while the instant product is brewed with impulses at minimum capacity.

By setting "100", both the instant product and water will be brewed at maximum capacity.

By setting "120" the pump works with impulses at minimum capacity, while the instant product is brewed at maximum capacity.

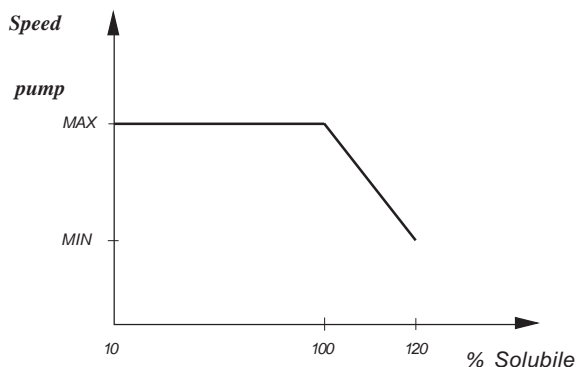
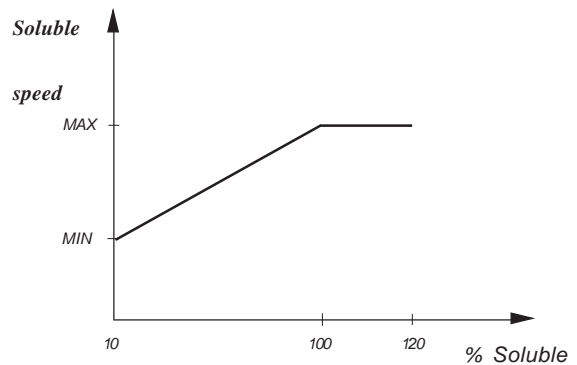

If pre-ground coffee is used, the %instant product item defines only the speed with which water is dispensed in the group, since the adjustment of the ground coffee brewing into the brewing cup has no effect on the end product.

The relationship between the water pump adjustment and the %instant product item is described in the table below:

% INSTANT PRODUCT	BREWING TYPE
100	Pump at 100%
110	Pump adjusted at 90%
120	Pump adjusted at 80%

### - Motor delay

This option allows entering a programmable engaging delay on instant product motors.

### - Coffee Water:

It defines the quantity of coffee to be brewed.

Example: 

BEVANDA	01
ACQUA CAFFE':	38

'38' indicates that 38 water units will be brewed. The quantity of coffee can be adjusted from '0' to '500' with steps of 2.

### - Sugar

It defines the quantity of sugar to be brewed with the beverage.

The following table shows the result of the different settings.

Setting	Sugar in the beverage without preselection	Sugar in the beverage with preselection
0	No sugar	Preselected quantity
1	1	Preselected quantity
2	2	Preselected quantity
3	3	Preselected quantity
4	4	Preselected quantity
NO	No Sugar	No Sugar

### - Beverage check:

It allows you to perform brewing tests on the beverage just set.

By pressing ENTER the display shows 'PRESS KEY' and you can choose which key to press based on the type of brewing test:

- Key 2 Full beverage;
- Key 3 Beverage without cup, sugar and stirrer;
- Key 4 Only water;
- Key 5 Only powder.

### TIMETABLE SETTING

The items of the TIMETABLE SETTING menu are:

- *Never free*  
Products and beverages supplied should be paid.
- *Always free*  
Products and beverages supplied are free.



### Important

When the Time Keeper module is present, it is possible to set:

- washing times;
- witching on and off times;
- differentiated pricing times;
- free dispensing times.

## PRICE MANAGEMENT

The items of the PRICE MANAGEMENT are:

### - Price table

99 price levels can be set.

### - Beverage prices

It allows to combine each beverage with one of the price levels set in the PRICE TABLE.

The combination can be:

- GLOBAL (all beverages are given the same price level);
- SINGLE (each beverage will be given a special price level).
- Global setting

By pressing the **UP** and **DOWN** keys and confirming with **ENTER**, it allows you to choose the price level to be combined with all beverages.

- Individual setting

It allows you to choose the price level for each beverage.

Select the beverage using the **UP** and **DOWN** keys and confirm with **ENTER**, then select the price level - from 001 to 099 - with **UP** and **DOWN** and confirm again with **ENTER**.

- **Cup Price** (displayed only if the Cup key is set in PRESELECTION mode)

It allows you to assign a price to the cup if cup preselection is activated.

The VMC will calculate the cost of the product based on two components:

- a beverage
- a cup

therefore the operator will have to set the price of both components. The amount paid by the user for each product is the sum of the beverage price plus the cup price.

Here is a practical example.

If:

price level 1 = 0.50

price level 2 = 0.05

	Beverage Price	Cup Price	Final Cost	Counters increased
<b>Beverage with cup</b>	Level 1	Level 1	0.55	Beverage counter and cup counter
<b>Beverage without cup</b>	Level 2	Level 2	0.50	Beverage counter

## 8.3 Maintenance menu

### 8.3.1 Accessing the maintenance menu



Open the door, insert the key into the safety switch (fig. 18) and press key P2, located on the CPU card (fig. 40, ref. 2) so as to enter the maintenance menu.

Press P2 again, remove the key from the safety switch and close the VM and wait for the self-configuration process to end.

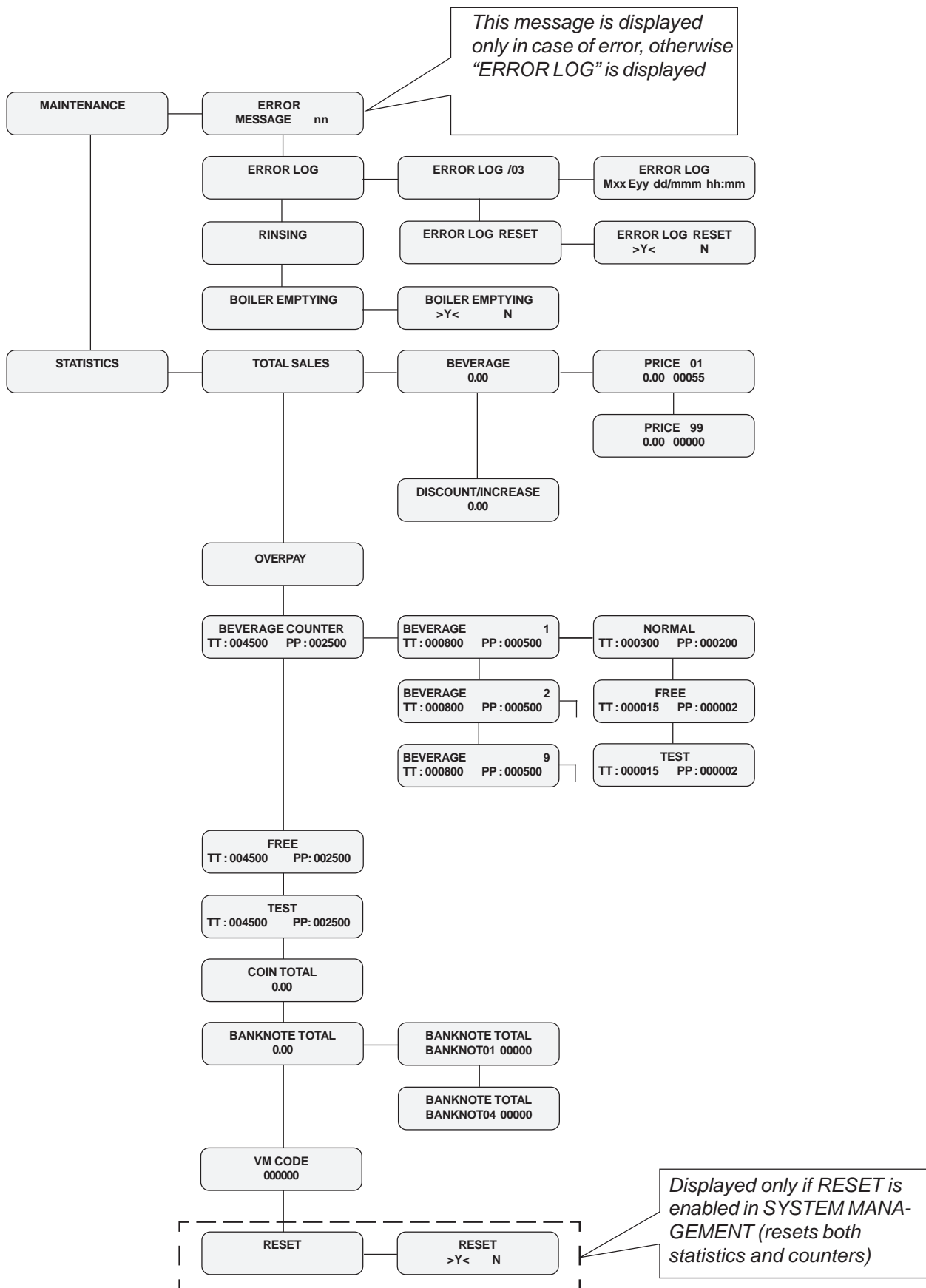

### 8.3.2 Description of maintenance menu messages



#### MAINTENANCE

This function allows to show and reset the errors that may be present. It is also possible to upkeep the vending machine.

The error can be reset through the maintenance menu or using the Automatic Error Reset mode.



#### Important

The latter, designed to be used by unskilled technical personnel, can be activated without entering the programming/maintenance menu and tries to remove automatically any (non-critical) error conditions that may occur in the V.M.

This mode does not eliminate all error conditions, but only those caused by operational defects.

Errors are divided into two groups (defect and failures) according to their criticality and therefore according to the easiness of removing the causes that determined them.

Defects include error conditions automatically recovered when their cause ceases to exist, as well as those conditions requiring an operator's intervention that, consequently, can be removed only upon the operator's request.

Failures, on the contrary, always require a technical intervention of skilled personnel.

The following table shows the error conditions divided into their two categories

Operational defects		Failures
Self-reset	automatic reset	manual reset
No cups (cod. 08) Drain tank full (cod. 09) No brew group (cod. 20)	No water (cod. 01) No coffee (cod. 02) Brew group blocked (cod. 03/04) Cup s blocked (cod. 10) Beverage/s blocked (cod. - -)	Flowmeter (cod. 05) Arm blocked (cod. 06/07) Boiler 1 temp. sensor (cod. 14) Eeprom memory (cod. 16) Cup basket blocked (cod. 17) No timekeeper (cod. 25) Position of decimal point (cod. 31)



#### Recommended solutions

In maintenance mode it is possible to:

- move the gear motor of the brew group by pressing beverage key 2;
- have the mixer rinsed by pressing beverage key 3;
- display for 5 seconds total and partial counters by pressing the beverage key 4.
- move the cup release / cup bracket gear motor by pressing beverage key 6;
- reset errors by pressing beverage key 8

#### - Error / Message nn

It describes the current error - check the cause in section 12 Error messages. If there are no errors present, this message is not displayed.

After checking the cause of the error, press the **ENTER** key to reset the vending machine - for the complete list of errors see section 12.



### - **Automatic Error Reset**

Simplified mode (for technical unskilled personnel) for error reset that, when implemented, tries to remove any non-critical error condition in the VM operation.

#### Starting the Error Reset Procedure

The error-reset procedure is started by pressing both the **P1** 'Programming' and **P2** 'Maintenance' simultaneously for at least 5 seconds - see fig. 40, ref. 1 and ref. 2.

A beep signals the procedure start.

#### Reset Procedure in Absence of Errors

If no failure is present, the display shows the message 'Ok - 0/0'. The user can go back to the standard mode by pressing **ENTER**.

In this way, a quick system check-up by the operator is also assured.

#### Reset Procedure in Presence of Errors

In presence of errors the procedure consists of two phases:

1. Error list;
2. Error removal (attempt to remove).

##### 1- Error list

The VM displays a list of errors detected. The first line of the display indicates the total number of errors 'ERRORS XX'.

The second one displays their descriptions on one or more screens. This list shows current error or trouble messages: Each message is displayed on a single screen page containing their descriptions, for example: 'NO WATER 01'. The user can pass to the following screen page by pressing **ENTER**.

By pressing **ENTER** again after viewing the last screen, the user will remove the errors.

##### 2 - Error removal (attempt to remove).

The VM tries, in sequential order, to remove the errors automatically. During this phase the error subject to the reset procedure is displayed;

In the second line of the display there is a 'status bar': the bar elements are made by points (".").

At the end of each attempt the display shows the message Ok/Fail and then proceeds with the following step.

If, at the end of the sequence, all the errors have been removed, the reset has been carried out successfully; otherwise - if one or more errors could not be removed - it failed.

#### Successful Reset

The VM shows the message 'Ok - N/N' with a long single beep.

N indicates the number of errors removed.

The vending machine is reset by pressing the **ENTER** key.

#### Reset failed

If, at the end of this procedure, at least one error condition remains unchanged, the display will show the message 'Fail X/N' where X is the number of errors that could not be removed and N the total number of errors detected.

The message is accompanied by some short beeps.

The vending machine is reset by pressing the **ENTER** key.

### - **Error Log**

The VM stores in its internal storage significant incidents occurring in the VMC (for example errors, trouble signals etc.)

The storage takes place at the detection of the error condition and consists in storing the following information:

1. error or failure code
2. location of the signal source  
(for instance, which spiral motor if the error is due to a spiral motor, or which coffee or instant product)
3. day, month, hour and minute of the error detection - this information is given only if the VM is equipped with a timekeeper.

The information is included in a list that can contain up to 50 elements, over that limit the information is stored starting by position 1 (previous information will be lost).

The following menu displays the LOG:

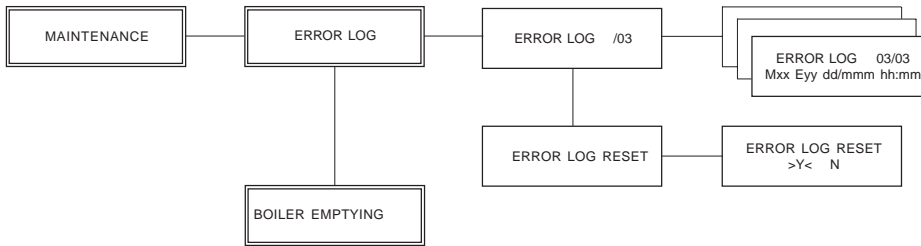

Notes:

All errors or faults are stored, except when blocks occur (coffee, instant product, beverage, water).

Ways of accessing stored information:

OPERATION	METHOD	DISPLAY MESSAGE
Accessing log	Using the Maintenance/ LOG MONITOR menu	LOG MONITOR Exx aabb ddmhhh hh:mm  <b>Exx</b> = error (Exx) or warning (Wxx) code <b>aabb</b> = Indicates “WHERE” the error has occurred (S = instant product, C = coffee, L = rinsing, e.g. S01 = instant product 01). <b>dd</b> = day of the month <b>mmm</b> = month <b>hh</b> = hour <b>mm</b> = minute Use ‘+’ and ‘-’ to scroll the list.
Resetting log	Use the appropriate menu	Actually, the log will not be erased, the VM will merely display the information stored subsequent to this operation
Viewing all the information (including cancelled information)	Enter the error list and press the beverage button 5	The VM will once again display all information.

### - Washing

It allows to rinse the brewing circuits of instant products.

By pressing the **ENTER** key the automatic cycle starts, thus activating in sequence each instant product circuit.



### Recommended solutions

To wash the circuit of a single instant product you need to keep the beverage keys pressed:

- Beverage key 2: instant 1 wash
- Beverage key 3: instant 2 wash
- Beverage key 4: instant 3 wash

### - Boiler emptying

It enables starting the automatic boiler discharging cycle.

## STATISTICS

This item enables displaying statistical data, total sales amount (which can be divided per beverage), total and partial number of brewings, the amount of coins and banknotes.

## 8.4 Software updating

The VM control program is in the flash memory inside the microcontroller.

The software can be updated by using an external EPROM or FLASH memory. The following is the general procedure of the operations to be carried out for the above mentioned updates.

### External EPROM or FLASH memory

The procedure is the following:

- turn off the vending machine;
- disassemble the TIMEKEEPER (if any);
- insert the external memory on a strip of 16x2 (fig.43) with the section showing PIN 1 turned upwards. Make sure the memory pins are all fully fitted, so that it perfectly fits the strip 16x2.

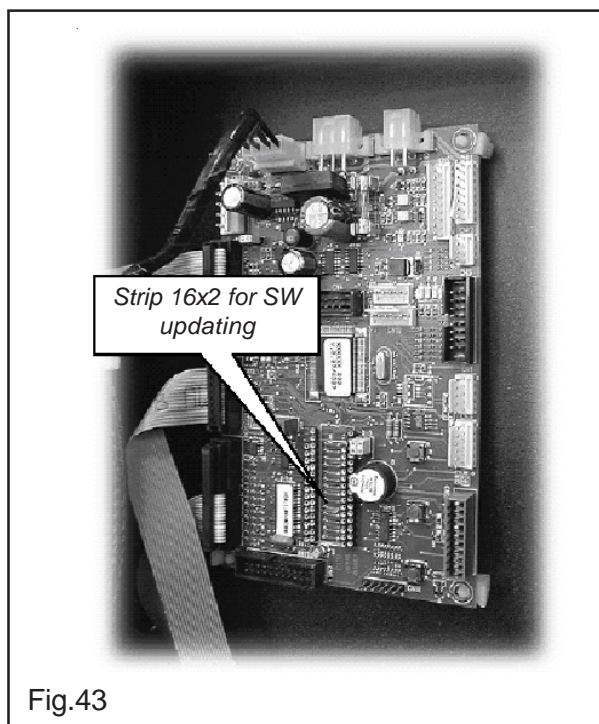

Fig.43

- switch on the vending machine. The vending machine checks if a suitable external memory is present. If this is the case, the following message is displayed:

PRESS P1 TO UPDATE  
FROM VX.yz > TO A.bc

- the message on the second line indicates that if the program is updated you will pass from the current version (X.yz) to the update flash version (A.bc);
- to upgrade the software press the internal key P1 (near the corner) of the CPU card, any other key will have no effect.
- The software requires about 30 seconds to be updated and the procedure end is signalled by a message on the display;
- turn off the vending machine;

UPDATE COMPLETED

- disassemble the external memory;
- assemble the TIMEKEEPER (if present).

## 9 - MAINTENANCE



### 9.1 Cleaning and loading



#### Important

Some operations should be carried out regularly in order to guarantee the correct operation of the machine; some of these operations are essential so as to comply with sanitary rules in force. These operations should be executed with the vending machine off and open; cleaning should be done prior to product loading.



#### Warning

*Wash components with warm water only, without using detergents or solvents that could change the shape and the performance of the machine. Do not wash removable components in the dishwasher.*

*During the cleaning and maintenance operations do not stress the machine electrical parts. Do not clean these electrical parts with wet clothes and/or degreasing detergents. Remove powder residues with a jet of dried compressed air or with an antistatic cloth.*

#### 9.1.1 Daily cleaning

It is aimed at preventing the proliferation of bacteria in the areas in contact with foodstuffs. These operations are to be performed with drinkable water, clean brushes and cloths.

Proceed as follows:

Remove and rinse carefully:

- powder conveyors, suction chamber, water conveyor ring, mixing chamber and fan, brewing spouts (fig.44)

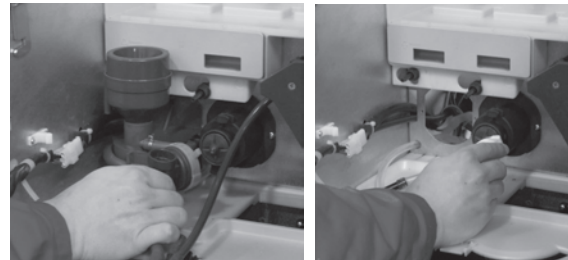

Fig.44

- brewing outlet - clean inside and outside - (fig.45 ref. 1 and ref. 2)

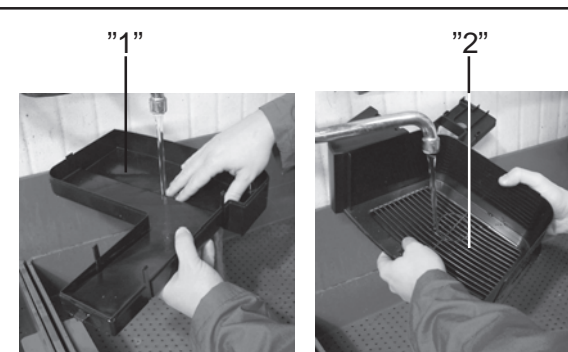

Fig.45

- remove the unit in order to make cleaning easier (fig.46) and then remove coffee powder residues with a brush.



Fig.46

- empty and clean the dump box (fig.47) or clean the conveyor.



fig.47

moisten a cloth and wipe carefully:

- all the visible parts of the brewing area (fig.49 and 50).



fig.49

- empty and clean the coffee residue drawer (fig.48)

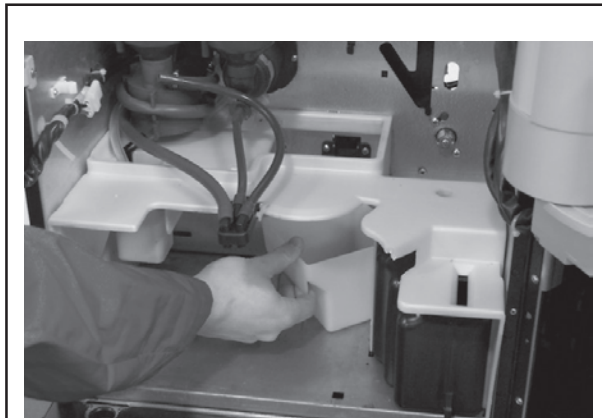

fig.48

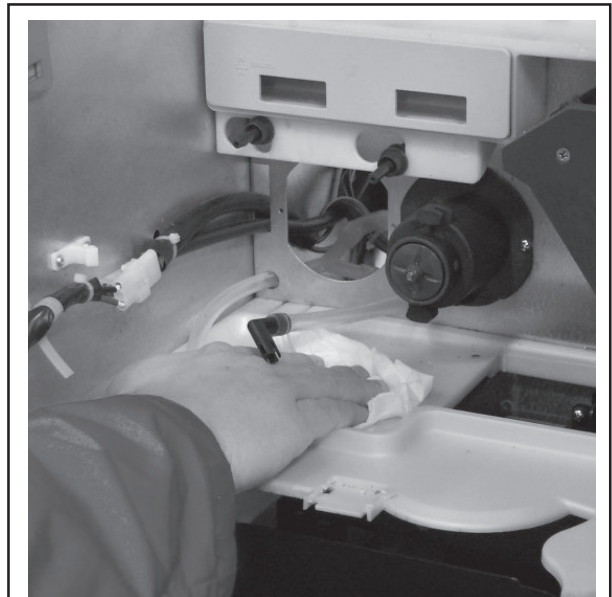

Fig.50

- the drain channel of the coffee group (fig.51).



Fig.51

- silicon drain hoses (fig.52)

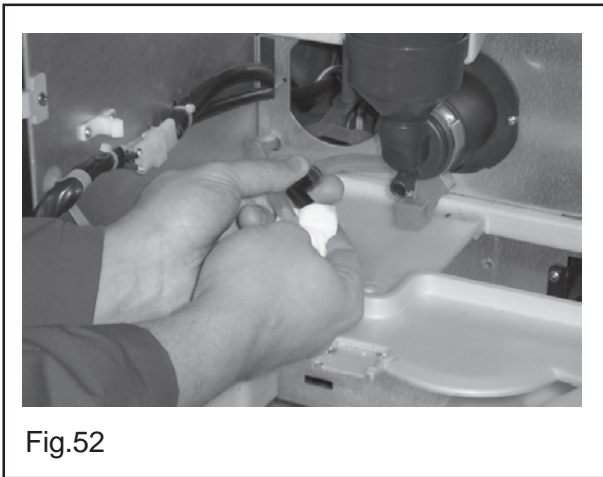

Fig.52



**Important**

Carefully blot all parts before reassembling them.

**9.1.2 Weekly cleaning**



Remove all containers and wipe with a damp cloth all container supporting areas, the bottom and outside of the machine and above all the brewing area (fig. 53).

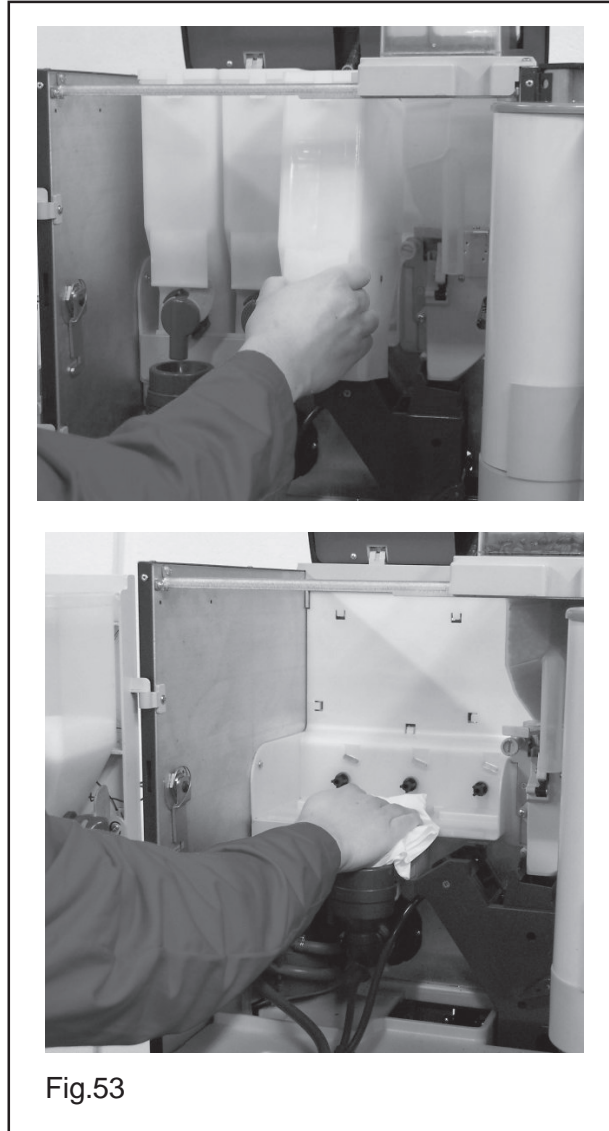

Fig.53

### 9.1.3 Product loading



Load products and/or consumable stores when necessary.

For these operations refer to the first-installation procedure, described in section 6.8.

## 9.2 Maintenance



	EVERY DAY	EVERY WEEK	EVERY MONTH	EVERY SIX MONTHS	EVERY 10,000 STROKES
Remove and rinse all the visible parts of the brewing area.	■				
Empty the liquid waste trays, rinse and/or replace them.	■				
Empty the dump box.	■				
Remove all containers and wipe with a damp cloth all container supporting areas, the bottom and outside of the machine and above all the brewing area.		■			
Disinfect all parts in contact with foodstuffs.			■		
Remove and rinse the COFFEE GROUP, lubricate all moving parts with silicon grease for food use.			■		
Replace gaskets and filters.					■



### Important

Carefully blot the upper and lower filter and blow with compressed air.

During cleaning and maintenance operations do not stress the following electrical parts: keyboard card, cpu card, dosing coil, sugar coil.

### 9.2.1 Scheduled and unscheduled maintenance



The operations described in this section are intended as an example as they depend on different variables, such as: water hardness, humidity, products used, conditions and quantity of work



#### Warning

*Make sure the vending machine is off before performing any operation requiring to disassemble some of its parts.*

Have the following operations performed by qualified personnel only. If the operations are to be performed with the machine on, choose trained personnel.

More complex interventions, such as removing limescale from the boiler, require a deep knowledge of the machine.

Disinfect all the parts in contact with foodstuffs using chlorine-based products on a monthly base, as described in section 4.0.

### 9.2.2 Brew group maintenance

Plastic group. It is advisable to remove it and rinse carefully with hot water on a monthly base; every 5,000 strokes and, in any case, every month all moving parts of the group must be lubricated with silicon grease for food use (fig.54).

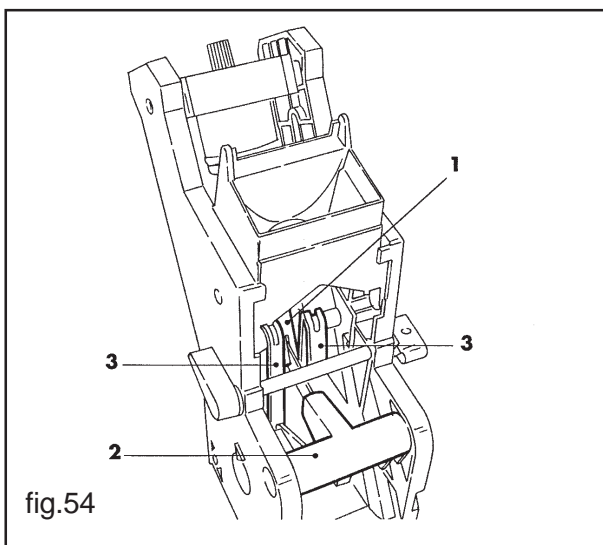

- lower filter rod (1).
- connecting rod (2)
- rails (3)

Replace gaskets and filters every 10,000 strokes.

- gaskets

Upper filter (fig. 55):

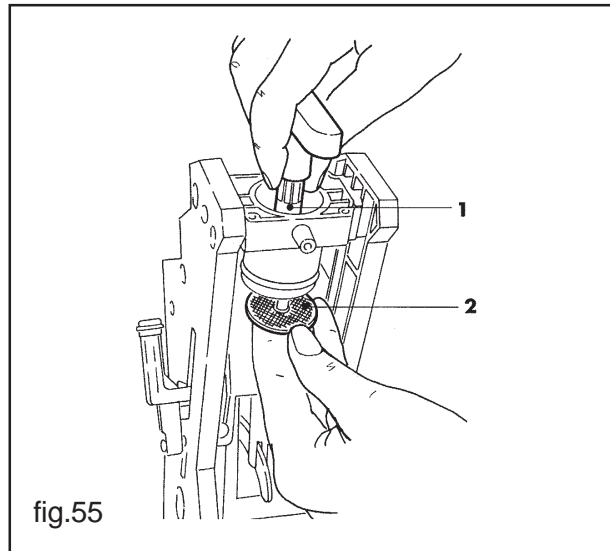

- loosen the upper pin (1) with the wrench supplied with the machine.
- manually unscrew the filter (2).

Lower filter:

- unscrew the two side screws (ref. 1, fig. 56) and remove the upper piston stop (2).

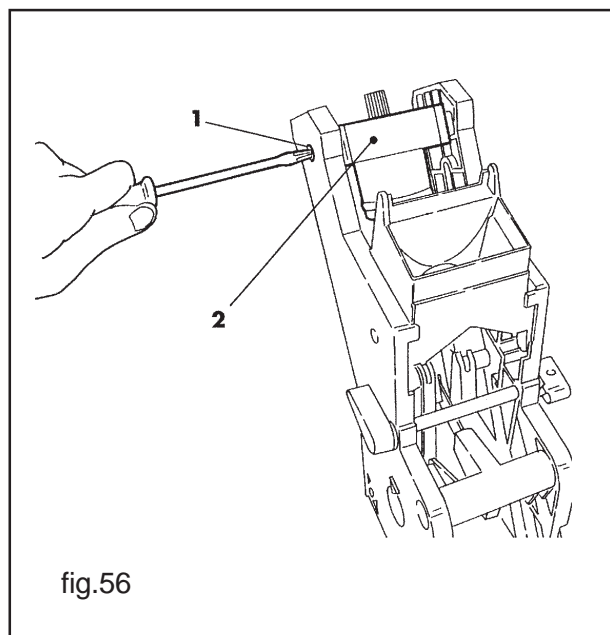



- manually rotate using the wrench supplied with the machine until the lower filter is flush with the cup (fig. 57).
- unscrew screw (1) and replace filter (2) (fig.57).
- reassemble all the parts following the reverse order.

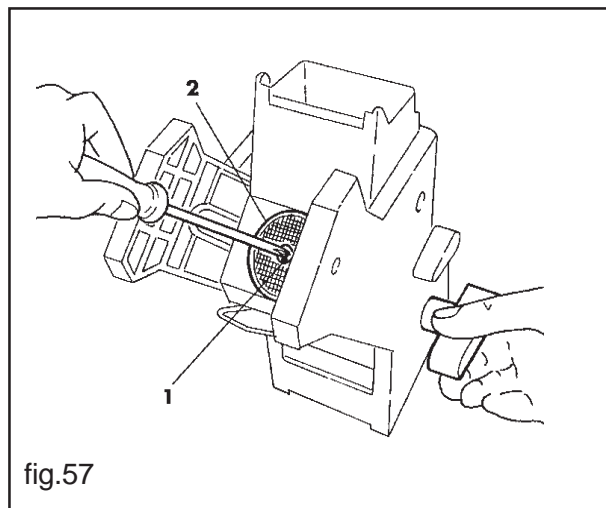

### Important

Carefully blot the upper and lower filter and blow with compressed air.

## 9.3 Adjustments



### 9.3.1 Dose and grinding adjustment



The vending machine is delivered having standard values set by the manufacturer, in particular:

- around 7.0 g of coffee powder

In order to make the most of the product used, check the following:

- ground coffee quantity adjustment. Modify the quantity used by means of the two levels of adjustment:
  - 1- coarse adjustment: release the adjustment lever from the rack and place the dragging tooth of the inner bulkhead on one of the 4 positions available, which indicate the basic quantity area (6 g – 7 g – 8 g – 9gr) (fig.58A)

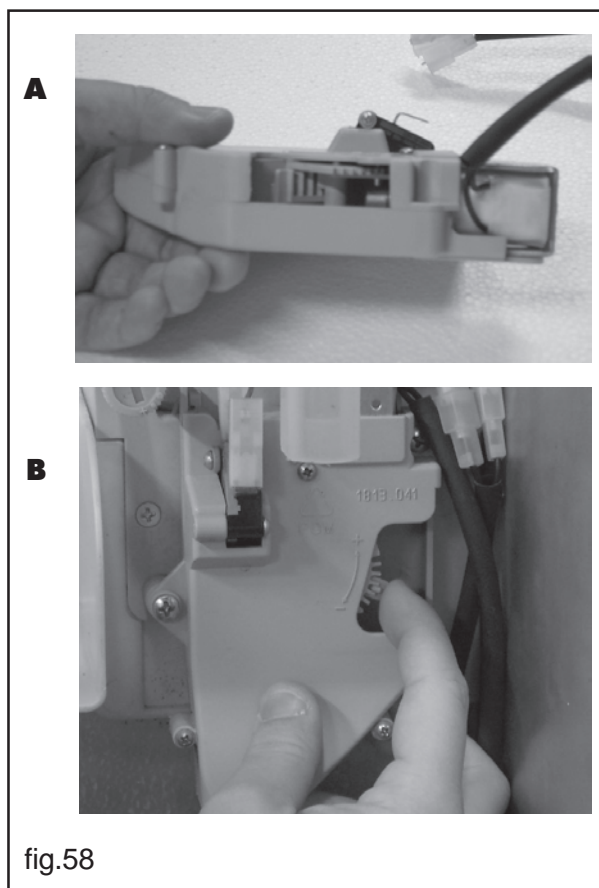

- 2- fine adjustment: engage the adjusting lever into the rack slot corresponding to the dose you require. (fig.58B).
- coffee grinding adjustment. Turn the rack (fig.59) until you get the grinding. After any adjustment three selections are necessary before the new setting becomes effective.

## 9.4 Cup releasing device cleaning and adjustment



### Importante

*Before removing the cup releasing device, make sure the cup bracket is in the brewing position - that is the fork that holds the cup is positioned under the brewing nozzles. If this is not the case, stop and then restart the machine to allow the automatic positioning of the cup bracket.*

Remove the release ring locking screw.  
Remove the device by unhooking the elastic hook of the ring (fig. 60)  
Check the satellite scrolls and, if need be, rinse the device so as to remove dirt.



fig.60



### Important

Carefully blow all the inner parts with compressed air before assembling the ring, making sure that the cup bracket is in the brewing position - that is the fork that holds the cup is positioned under the brewing nozzles. If this is not the case, stop and then restart the machine to allow the automatic positioning of the cup bracket.

Reassemble the release ring making sure that the operating knob arrow is aligned with the reference notch on the cup dispenser housing (fig.61)



fig.61

In case of disassembly of all the internal parts of release ring assembly, refer to the specific assembling instructions (fig.62)

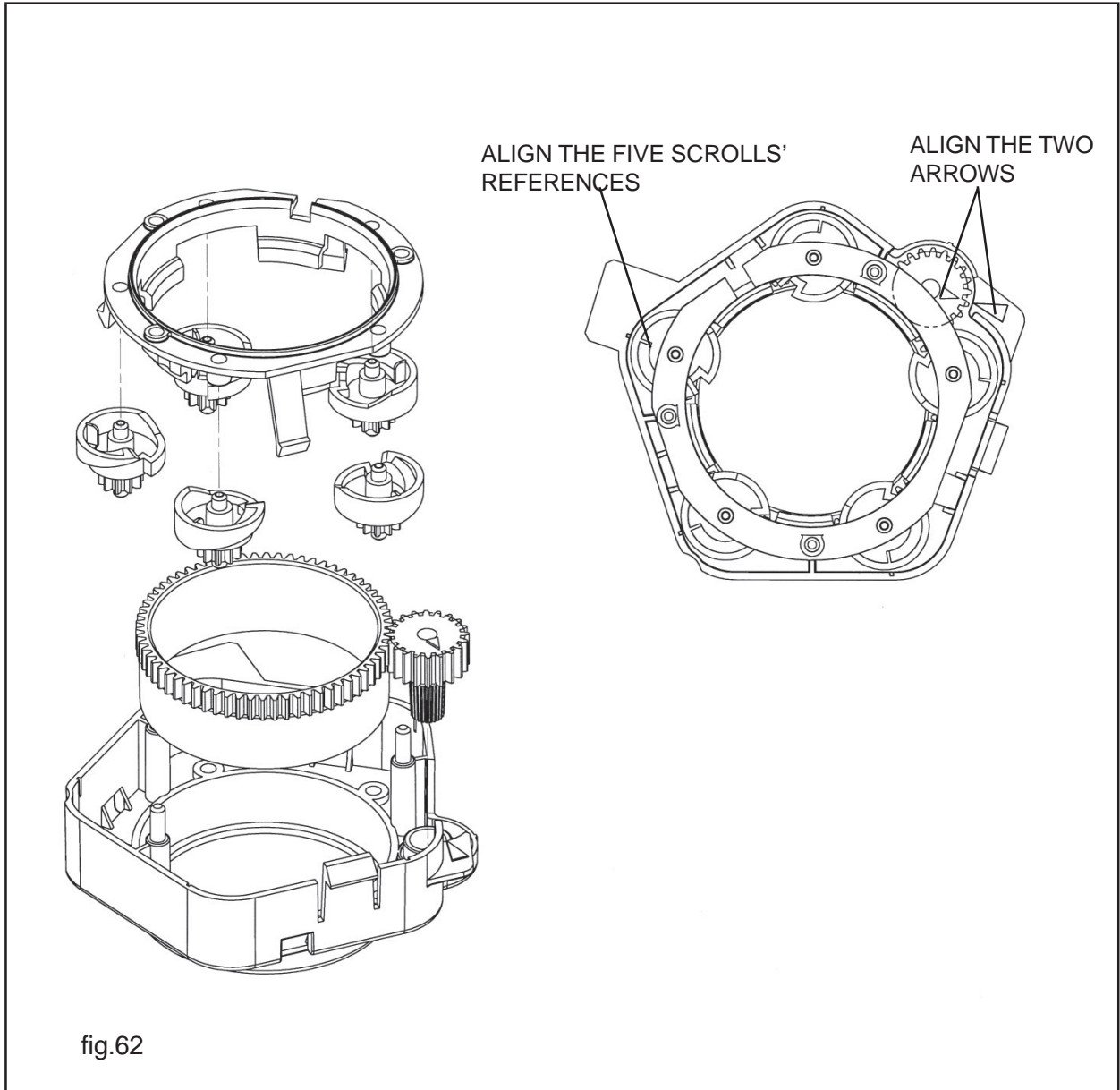

### 9.5 Resin regeneration (where the water softener is provided)



Resin regeneration is to be carried out according to the water of the system to which the dispenser is connected.

Use the table below as a reference:

WATER HARDNESS	SELECTION NUMBER	
	60cc	130cc
°French		
10	25000	12500
20	12500	6000
30	9500	4500
40	6500	3000
50	5000	2500

The appropriate kits available on the market can be used to check water hardness and therefore the times and modes for intervention.

The operation can be carried out as follows:

- power the machine off
- turn the lower tap taking care to place the related hose into a bucket or better into a drain system (fig.63).

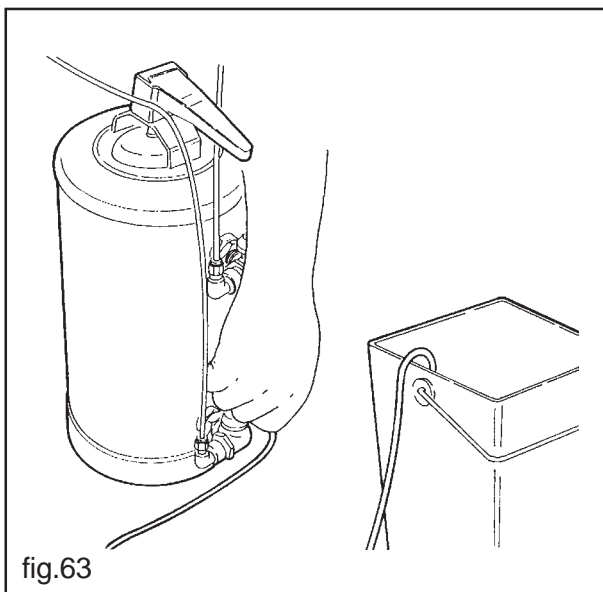

- remove the cover and introduce 1.5 kg salt
- refit the cover
- turn the machine on and drain the water until it is no longer salty
- power the machine off and close the tap.

This operation takes about 30/45 minutes.

## 10 - INACTIVITY



If the automatic vending machine remains inactive for a long time it is necessary to take certain preventive measures:

- with the machine on, start the automatic emptying process of both the hydraulic circuit and the boiler (see PROGRAMMING AND MAINTENANCE MENU in section 8).
- once it is over, disconnect the machine from the power and hydraulic supply
- disassemble the closing panel on the back of the machine.
- complete the emptying of the tank with float by removing the hose clamp located on the air-break device drain hose
- once the emptying is over, refit the hose clamp (fig.64)

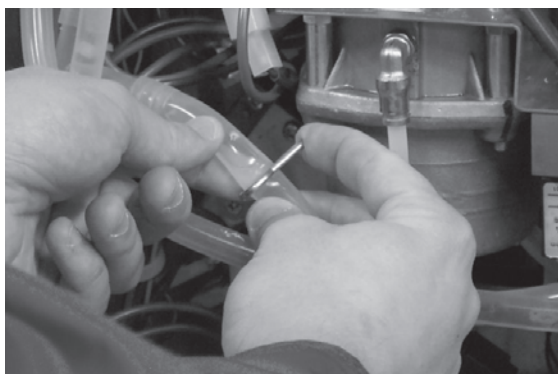

fig.64

- assemble the closing panel on the back of the machine.
- unload all products from the containers
- wash all the components that are in contact with foodstuff as previously described
- empty the trays from dry and liquid dumps, then clean them accurately
- clean all vending machine internal and external surfaces with a cloth
- protect the outside of the machine with plastic film or a bag
- store in dry, sheltered environments at a temperature not lower than 1°C

## 11 - DISMANTLING



Empty the products and water as described in the previous section. For dismantling, it is advisable to disassemble the machine parts according to their composition - plastic, metal etc. Afterwards, deliver the divided parts to the specialised companies. If a refrigerating unit is present, give it without disassembling it to companies authorized for the disposal of this particular part.

# 12 -TROUBLESHOOTING GUIDE FOR THE MOST COMMON FAILURES OR ERRORS



## DISPLAY MESSAGES

This section will show the messages displayed:

1. during normal operation;
2. in case of failure (error messages).

### Messages during operation

The table below shows a list of messages displayed during the standard operating phases.

Error code	Messaggio	Cause	Cure
/	RUBINO 200	The vending machine is waiting	
/	WAIT FOR PRODUCT	Beverage dispensing in progress	
/	SUGAR 1-X SUGAR 2-XX SUGAR 3-XXXXX SUGAR 4-XXXXXXX	SUGAR QUANTITY to be dispensed with the beverage.	
/	PRESELECTION	preselection enabled	
/	COFFEE NOT AVAILABLE	Coffee bean container is empty	Carry out the supply (see section 7)
/	NOT AVAILABLE	Type of product not available	
/	NO CHANGE AVAILABLE	The coin stacking tube level is under the preset limit	Add coins into the change giving coiner
/	NO LINK	The VM does not detect any communication if the payment system is selected	Check the dialogue with the payment system

## Out of service/Failure conditions

In particular situations, the VM can be fully or partially out of service.

There are 3 categories (classified by severity):

- A. failures due to scheduled maintenance conditions which partially block the VM. By these failures (out of coffee, too many dump in the box, out of cups – in case of cup preselection) the VM is not out of service but its dispensing function is somehow limited ;
- B. failures due to scheduled maintenance conditions which block the VM fully. By these failures (out of cups, no water, too many dumps in the box, too high water level in the residues tray) the VM product dispensing is disabled, thus inhibiting the payment systems;
- C. out of service conditions which disable the entire VM. The VM is brought to this condition when it detects failures which are not solvable with scheduled maintenance. In this condition, the payment systems are inhibited and no VM load can be operated.

The following table resumes all failure and/or error conditions which may occur on the VM, listing for any of them:

- possible cause description
- category;
- associated code (i.e. the code shown in maintenance and registered in the error log);
- effect on the VM state;
- how to restore the VM normal operation - once the failure/error cause has been removed

Description	Failure/ error category	Error code - if any	Effect on the VM	Reset to normal operation			
				Manual reset	Simplified reset	Self-reset	Reset by start-up
no water (see air-break device control section)	B/C	1	stop VM	SI	SI*	YES (the VM makes 20 attempts, one every 10 minutes, in case of failure, it displays error 01)	SI
no coffee	A	2	stop beverages with coffee beans	SI	SI	NO	NO
brew group did not reach the dispensing position	A	3	Stop beverages which use the group	YES	YES*	NO	YES
brew group did not reach the rest position	A	4	Stop beverages which use the group	YES	YES*	NO	YES
turbine impulses not read	B	5	stop VM	YES	NO	NO	NO
cup bracket not in position	A/B	6	beverages without cup / stop VM	YES	NO	NO	YES
no cups	A/B	--- (8)	beverages without cup / stop VM	---	---	YES	YES
dump tray	B	--- (9)	stop VM	---	---	YES	YES
the cup release mechanism did not end its movement	A/C	10	beverages without cup / stop VM	YES	YES	NO	YES
wrong value of the temperature sensor	C	14	stop VM	YES	NO	NO	YES
corrupted data in eeprom data	C	16	stop VM	YES	NO	NO	YES
no brew group	A	20	stop beverages with coffee beans	YES	YES*	YES	YES
no dump box	B	--- (21)	stop VM	---	---	YES	YES
the last three coffees had a scarce brewing flow	A	22	Stop beverages which use the group	YES	YES	NO	NO
pump error	failure	23	failure record only				
saeco card without clock (timekeeper)	C	25	stop VM	YES	NO	NO	YES
payment system decimal point not in line with the VM settings	C	31	stop VM	YES	NO	---	YES
(credit handler signal)	---	32	signal only	---	---	---	---



Description	Failure/ error category	Error code - if any	Effect on the VM	Reset to normal operation			
				Manual reset	Simplified reset	Self-reset	Reset by start-up
voluntary VM stop	C	33	stop VM		NO	NO	NO
(signal of the successful recovery of the scarce flow coffee)	---	34	signal only		---	---	---
(BDV error signal)	---	41	signal only		---	---	---
Operation of the watch dog timer	---	72	signal only		---	---	---
Error in the MDB* coiner	---	80**	signal only		---	---	---
presence of a beverage or coffee stop	A	---	stop relevant beverages	YES	YES	NO	NO

\* Only MDB coiners of 3rd level or higher

\*\* The error of the change-giving coiner is identified by two codes Z1 and Z2 on the right of the W80 mark in the error log. As regards to the error description, please refer to the MDB protocol manual.

To bring the vending machine back into full working order, you need to remove the cause of the failure and possibly carry out the error reset procedure described in section 8.3.1.

# 13 - VISUAL SIGNALS (LED)

## On the CPU card

LED	State	Function
DL1- TX	Flashing	Data transmission from the CPU to serial payment systems (EXEC, BDV, MDB)
DL2- RX	Flashing	Data reception from serial payment systems (EXEC, BDV, MDB)
DL3	Flashing	Program on the CPU is running – fast flashing while starting up the VM or by any error/failure
DL4	—	—
DL5	Permanently on	Presence of the power +5V
DL6	Permanently on	MDB, BDV and Executive payment systems with +24V power supply.

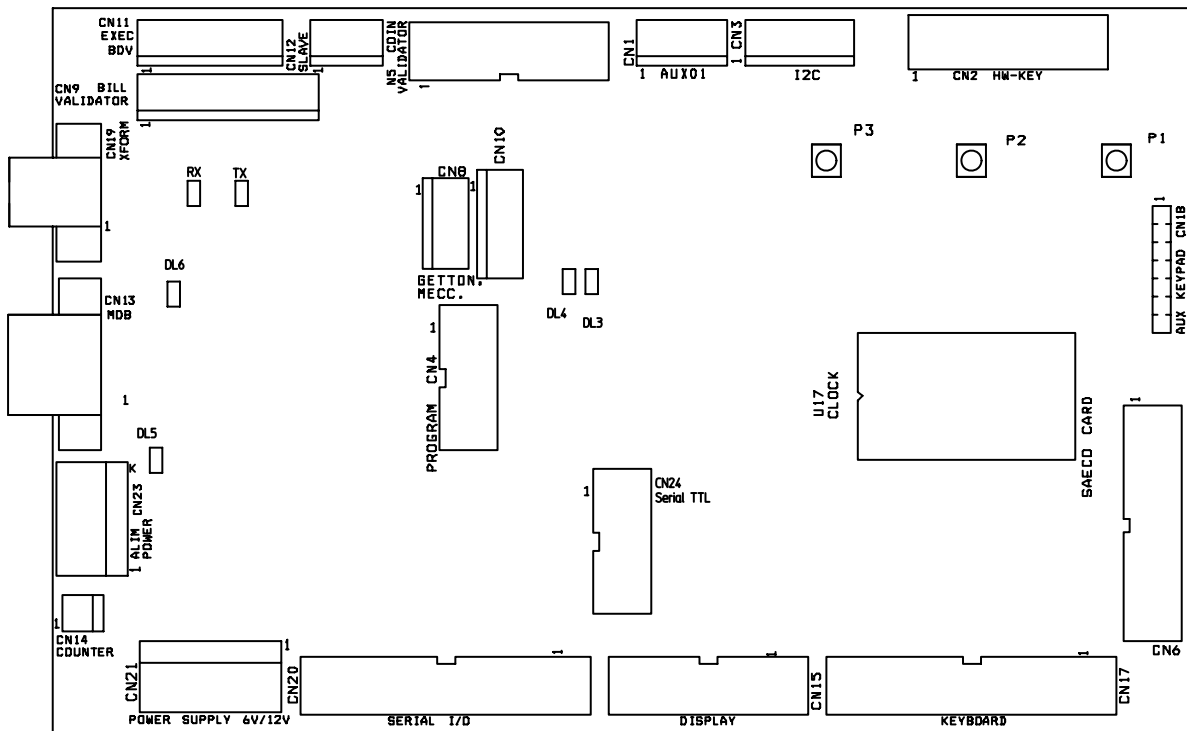

CN21	= optional feeder kit for payment systems
CN20	= POWER card connection
CN15	= display
CN17	= keyboard
CN6	= Saeco Card module
CN18	= auxiliary buttons
CN2	= copy key
CN16	= external buzzer
CN3	= external I2C devices
CN1	= product releasing control (spirals)
CN5	= 24Vdc parallel coin validator
CN12	= EXECUTIVE slave
CN11	= EXECUTIVE/BDV/MDB slave payment systems
CN9	= parallel banknote validator
CN19	= EXECUTIVE/BDV/MDB systems power supply inlet
CN13	= MDB payment systems
CN23	= power supply from POWER card
CN14	= 24Vdc electromechanical pulse counter
CN4	= firmware programming
CN8	= mechanical coiner
CN10	= cancelling machine
CN24	= serial connection for RS232 and IRDA modules
U6	= 32 pin base for firmware updating eprom
U17	= timekeeper base

## On the Power card (I/O)

LED	State	Function
DL1	On	Power 24 V
DL2	On	Cup empty microswitch (cups available)
DL3	On	Cup release microswitch
DL4	On	Cup bracket microswitch
DL5	On	Drain tank microswitch
DL6	On	Brew group presence microswitch
DL7	On	House group microswitch
DL8	On	Coffee dosing unit microswitch
DL9	On	Auxiliary microswitch
DL10	On	Auxiliary microswitch
DL11	On	Air-break microswitch
DL12	Flashing	Turbine sensor impulses
DL13	On	Boiler enabled

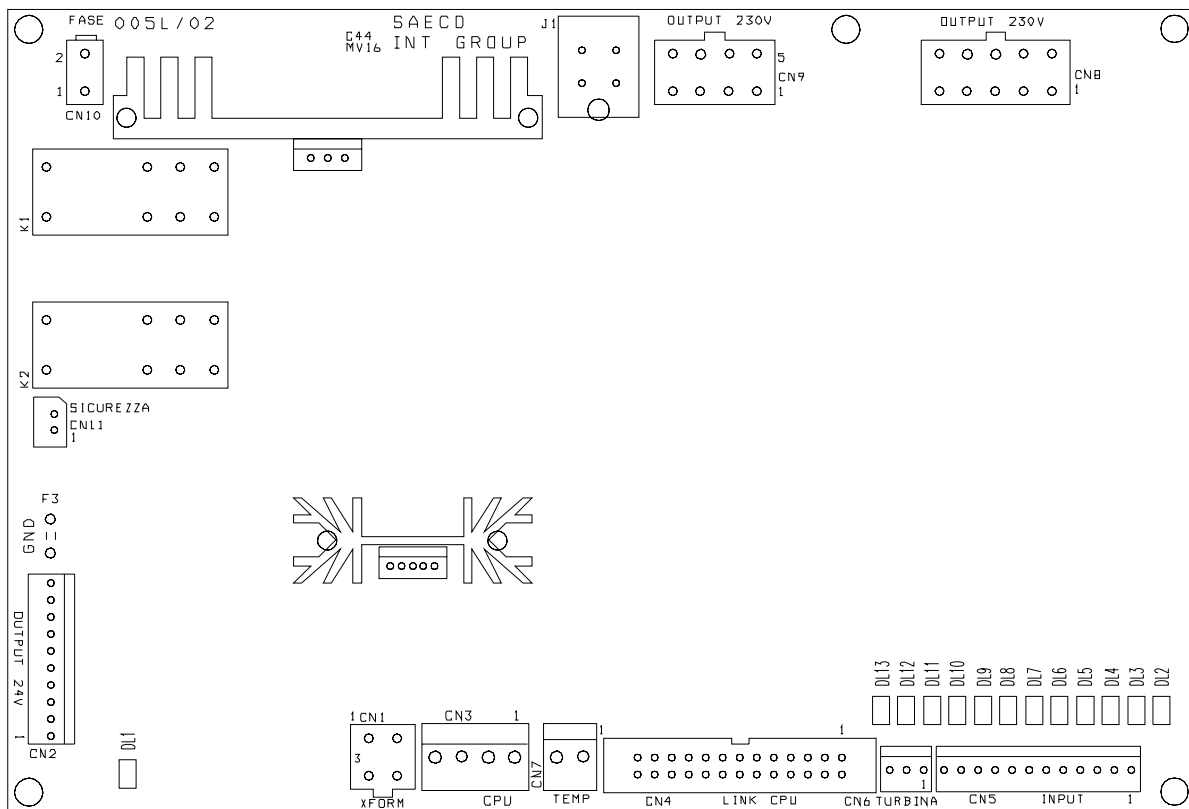

- CN8 = high voltage actuator connectors (and NEUTRALinput)
- CN9 = high voltage actuator connectors (and NEUTRALinput)
- CN10 = high voltage input connector (PHASE)
- CN11 = dump box presence microswitch connector
- CN2 = low voltage actuator connector
- CN1 = transformer input connector
- CN3 = CPU card supply
- CN7 = temperature probe connector
- CN4 = CPU card connection
- CN6 = flowmeter connectors
- CN5 = microswitch connectors

## 14 INSTRUCTIONS FOR END-OF-LIFE DISPOSAL TREATMENT

This product complies with EU Directive 2002/96/EC.



The symbol  on the product or on its packaging indicates that this product may not be treated as household waste. Instead it shall be handed over to the applicable collection point for the recycling of electrical and electronic equipment.

By ensuring this product is disposed of correctly, you will help prevent potential negative consequences for the environment and human health, which could otherwise be caused by inappropriate waste handling of this product. For more detailed information about recycling of this product, please contact your local city office, your household waste disposal service or the shop where you purchased the product.

### Important

The disposal of the vending machine or of a part of it must be carried out with full respect of the environment and according to local laws in force.

**Notes:**

**Notes:**

Cod. 1813-956-ED07

For more information visit [www.Gumball.com](http://www.Gumball.com) | 800-260-0010 | +1-214-550-5079