

# **ruggedBOARD – A5D2x**

## **Hardware Manual**

**Document No.** : **RB-HWR-001-A0**  
**SBC Part No.** :  
**CB PCB Number** :  
**SOM PCB Number** :

**Edition – March, 2019**

## Conventions, Abbreviations and Acronyms

This hardware manual describes the phyCore-A5D2x, the following is referred to as Industrial ruggedBOARD. The manual specifies the Industrial ruggedBOARD's design and function. Precise specifications for the Texas Instruments A5D2x microcontrollers can be found in the Texas Instrument's A5D2x Data Sheet and Technical Reference Manual.

SIP	System-In-Package
SOM	System On Module
DDR2-SDRAM	Double Data Rate 2 Synchronous Dynamic Random-Access Memory
DSC	Direct Solder Connection
ESD	Electrostatic discharge
Mbit	Megabit
EMI/EMC	Electromagnetic Interference/Electromagnetic Compatibility
DDR	Double Data Rate
BGA	Ball Grid Array
RTC	Real-Time Clock
USB	Universal Serial Bus
TFT-LCD	Thin Film Transistor - Liquid Crystal Display.
ADC	Analog-to-Digital Converter
PWM	Pulse width Modulation
QSPI	Queued Serial Peripheral Interface
UART	universal asynchronous receiver-transmitter
IIC	Inter-Integrated Circuit
eMMC	embedded Multi-Media Controller"
PCB	Printed Circuit Board
PMIC	Power Management IC
POR	Power On reset
GPIO	General Purpose Input/output

## List of Figures

Figure 1	:	Connectors and PIN Header.....	12
Figure 2	:	Block Diagram.....	13
Figure 3	:	Power in.....	14
Figure 4	:	USB PWR / DBG CONSOLE.....	14
Figure 5	:	Ethernet.....	15
Figure 6	:	Secure digital Memory card + SIM (Dual Connector).....	16
Figure 7	:	RS-232.....	17
Figure 8,9	:	DIN and DOUT(0-24V).....	17
Figure 10	:	USB 2.0.....	18
Figure 11	:	RS-485.....	19
Figure 12	:	CAN Interface.....	19
Figure 13	:	Expansion Header.....	20
Figure 14	:	RTC Battery.....	22
Figure 15	:	User LED GPIO.....	22
Figure 16	:	DBG PORT.....	23
Figure 17	:	LCD Connector.....	23
Figure 18	:	mPCIe Connector.....	24
Figure 19	:	ATWILC3000.....	26
Figure 20	:	mikroBUS Connector.....	28
Figure 21	:	mikroBUS Standard PIN outs.....	29

## List of Tables

Table 1	: Features.....	9
Table 2	: Overview.....	11
Table 3	: Power Information.....	14
Table 4	: USB PWR / DBG CONSOLE .....	14
Table 5	: Ethernet.....	15
Table 6	: Secure digital Memory card + SIM (Dual Connector).....	16
Table 7, 8,9	: RS232 DIN and DOUT(0-24V).....	17
Table 10	: USB 2.0.....	18
Table 11	: RS-485.....	20
Table 11	: CAN Interface.....	20
Table 12	: Expansion Header.....	20
Table 13	: RTC Battery.....	22
Table 14	: User LED GPIO.....	22
Table 15	: DBG PORT.....	23
Table 16	: LCD Connector.....	23
Table 17	: mPCIe Connector.....	25
Table 18	: ATWILC3000.....	27
Table 19	: mikro-BUS Connector.....	29
Table 20	: Power Consumption.....	31

## Table of Contents

i)	LIST OF FIGURES.....	2
ii)	LIST OF TABLES.....	3
	Table of Contents.....	5
	<b>Ordering Information</b> .....	6
	<b>Product Specific Information and Technical Support</b> .....	6
	<b>Declaration of Electro Magnetic Conformity of the ruggedBoard [To Be Decided]</b> .....	7
1.	INTRODUCTION .....	9
1.1.	Hardware overview .....	9
2.	Accessing the RuggedBOARD.....	11
2.1.	Overview .....	11
2.1.1.	Connectors and PIN Header.....	12
2.1.2.	Block Diagram .....	13
2.2.	Functional Components .....	13
2.2.1.	Power Supply (P2) .....	13
2.2.2	Ethernet (J3).....	15
2.2.3	Secure digital Memory card + SIM (Dual Connector) (J4).....	16
2.2.4	RS-232 (P4).....	17
2.2.5	DIN and DOUT(0-24V) (P5 and P6).....	17
2.2.6	USB 2.0 (P7).....	18
2.2.7	RS-485 (P9).....	19
2.2.8	CAN (P9) .....	19
2.2.9	Expansion Header (P10) .....	20
2.2.10	RTC Battery (P11) .....	22
2.2.11	User LED GPIO (D17, D7, D4) .....	22
2.2.12	DBG PORT (P13) .....	23
2.2.13	LCD Connector (P16) .....	23
2.2.14	mPCIe Connector (P8).....	24
2.2.15	ATWILC3000 (U17) – [Optional Mount].....	26
2.2.16	mikro-BUS Connector (M1).....	28
2.2.17	Real Time Clock Module with I <sup>2</sup> C-Bus .....	29
2.2.18	POWER CONSUMPTION TABLE .....	31

**Note:** The BSP delivered with the phyCORE-A5D2x usually includes drivers and/or software for controlling all components such as interfaces, memory, etc. Therefore, programming close to hardware at register level is not necessary in most cases. For this reason, this manual contains no detailed description of the controller's registers, or information relevant for software development. Please refer to the A5D2x *Reference Manual*, if such information need to connect customer designed applications.

## Ordering Information

The part numbering of the phyCORE-A5D2x has the following structure:

**CHECK AND ORDER ONLINE!!**

[www.ruggedboard.com](http://www.ruggedboard.com)

## Product Specific Information and Technical Support

In order to receive product specific information on changes and updates in the best way also in the future, we recommend to register at:

<http://www.ruggedboard.com/> or <https://ruggedboard.wixsite.com/rugged-board/forum>

Contact Information	
Address	PHYTEC Embedded Pvt. Ltd. 27th Main, HSR Layout, Bengaluru 560102
Phone Number	+91-9741652770
E-Mail	<a href="mailto:info@ruggedboard.com">info@ruggedboard.com</a>
Technical Support	<a href="https://ruggedboard.wixsite.com/rugged-board/forum">https://ruggedboard.wixsite.com/rugged-board/forum</a>
Website	<a href="http://www.ruggedboard.com">www.ruggedboard.com</a>

Assembly options include choice of Controller; RAM (Size/Type); Size of NOR Flash, etc.; Interfaces available; Vanishing; Temperature Range; and other features. Please contact our sales team to get more information on the ordering options available.

## Declaration of Electro Magnetic Conformity of the ruggedBoard [To Be Decided]



phyCORE-A5D2x: RuggedBOARD System on Module (henceforth products) are designed for installation in electrical appliances or as dedicated Evaluation Boards (i.e.: for use as a test and prototype platform for hardware/software development) in laboratory environments.

### Caution!

RuggedBOARD products lacking protective enclosures are subject to damage by ESD and, hence, may only be unpacked, handled or operated in environments in which sufficient precautionary measures have been taken in respect to ESD-dangers. It is also necessary that only appropriately trained personnel (such as electricians, technicians and engineers) handle and/or operate these products.

RuggedBOARD products fulfill the norms of the European Union's Directive for Electro Magnetic Conformity only in accordance to the descriptions and rules of usage indicated in this hardware manual (particularly in respect to the pin header row connectors, power connector and serial interface to a host-PC).

### Note:

Implementation of RuggedBOARD into target devices, as well as user modifications and extensions of RuggedBOARD products, is subject to renewed establishment of conformity to, and certification of, Electro Magnetic Directives. Users should ensure conformance following any modifications to the products as well as implementation of the products into target systems.

Products EMI/EMC standards test Specifications and qualified for CE

- IEC/EN 61000-4-6 (RE conducted susceptibility test) : 1G to 3G
- IEC/EN 61000-4-2 (Electro Static Discharge immunity test)
- IEC/EN 61000-4-5 (Surge immunity test)
- **IEC /EN\*\* Vibration Test (Shockproof with Multiple drops from 5' (1.5 m) (TBD)**

## ESD Warning:



Electronic components and circuits are sensitive to Electrostatic Discharge (ESD). When handling any circuit board assemblies including Pico Computer carrier assemblies, it is recommended that ESD safety precautions be observed. ESD safe best practices include, but are not limited to:

- Leaving circuit boards in their antistatic packaging until they are ready to be installed.
- Using a grounded wrist strap when handling circuit boards, at a minimum you should touch a grounded metal object to dissipate any static charge that may be present on you.
- Only handling circuit boards in ESD safe areas, which may include ESD floor and table mats, wrist strap stations and ESD safe lab coats.
- Avoiding handling circuit boards in carpeted areas.
- Try to handle the board by the edges, avoiding contact with components

## Power Supply Warning:



Hardware Power Supply Limitation: Powering the board with voltages higher than **3.3V ± 5%** may damage the module. We recommend Supply voltage to SOM module from Carrier Board is **3.3V ± 5%**.

In addition, for proper operation of the module into the target application also requires connecting all GND pins common.



# 1. INTRODUCTION

## 1.1. Hardware overview

The ruggedBOARD-A5d2x for phyCORE-A5D2x modules is a low-cost, feature-rich software development platform supporting the microchip Semiconductor phyCORE-A5D2x microprocessors. Moreover, due to the numerous standard interfaces the ruggedBOARD-A5D2x can serve as bedrock for your application. At the core of the ruggedBOARD phyCORE-A5D2x is the phyCORE A5D2x System On Module (SOM), containing the processor, DRAM, NAND Flash, power regulation, supervision, transceivers, and other core functions required to support the phyCORE A5d2x processor. Surrounding the SOM is the ruggedBOARD phyCORE-A5D2x carrier board, adding power input, buttons, connectors, signal breakout, and Ethernet connectivity amongst other peripherals.

The phyCORE-A5D2x is a connector-less, BGA style System On Module (SOM) in a direct solder form factor. Unlike traditional Phytex SOM products that support high density connectors, the phyCORE-A5D2x SOM is directly soldered down to the ruggedBOARD-A5D2x using Half-Hole Technology. This solution offers an ultra-low cost Single Board Computer for the phyCORE-A5D2x processor, while maintaining most of the advantages of the SOM concept.

Adding the phyCORE-A5D5x into your own design is as simple as ordering the connected version and making use of our rugged Board’s Carrier Board reference schematics.

### Features:

The Industrial ruggedBOARD has the following features.

Name	Interface	Numbers	Details
Input DC Power Supply	Power Section		Either USB or 5V DC Power adaptor (~1.5 to 2A )
Power Management	Power Section		Step -down regulators
RTC Power Header (3V) Use SOM Internal RTC function	Power Section		RTC power Header : 2 Pin
Reset Switch(Board at board Edge) 2pin SMD	Reset Dedicated	1	
User Switch ; GPIO Control	User Switch	1	
Debug Port : TTL 3.3V as well USB Micro Port	UART /USB	1	3 pin Header / USB Port Via FTDI Bridge chipset
Combi Connector : uSIM and uSD Socket	SDIO and SIM	1	
Ethernet RJ45 Connector(10BASE-T/100BASE-TX)	10/100 ETHERNET MDI	1	
USB 2.0 Host Port/ GSM/Wifi	USB 2.0	2	Dual Port Stack USB Header
CAN Interface (Transceiver Non Isolated)	CAN interface	1	5 Pin Header ; Shared between RS485 and CAN

Serial Port RS485 (Non-Isolated)	UART	1	5 Pin Header ; Shared between RS485 and CAN
Serial Port RS232 (Non-Isolated) and with Full Modem (RTS,CTS)	UART	1+1	5 Pin Header : Configured as Full Modem / Half Modem
Digital Inputs x 4 (Isolated ) upto 24V Support	GPIO	1	5 Pin Header
Digital outputs x 4 (Isolated ) upto 24V Support	GPIO	1	5 Pin Header
mikroBus Header	SPI,UART,I2C,PWM , INPT	1	Female header
LED's (Power , User Configurable LED's)	GPIO	4	On board as well Panel Mount Header provision
LCD Back Light Circuit (Fixed Voltage)	Power Section	1	
LCD Interface FPC lock type Connector	RGB with Control Signals	1	
SAM L11 (RTC,WTD,RTC) with 3.3V Expansion Header	GPIO	1	24 Position
Pico Expansion Header: GPIO's	GPIO	1	60 Position
PCB Form factor: Board Size : 100x72.5mm			4 layer impedance controlled PCB

Table 1

## 2. Accessing the RuggedBOARD

Rugged board's Industrial picoComputer is fully equipped with all mechanical and electrical components necessary for the speedy and secure start-up.

### 2.1. Overview

The Industrial ruggedBOARD is depicted in Figure 2. It features many different interfaces and is equipped with the components as listed in Table 2, and Table 3. For a more detailed description of each peripheral refer to the appropriate chapter listed in the applicable table. Figure 2 highlights the location of each peripheral for easy identification.

Reference Designator	Description	Temperature Parameters
P1	Power Supply 5V (1. Phoenix combicon 3-pole connector) <b>TBD</b> (Power IN 5V as well 24V DC IN ( While Using 24V DC IN, USB Ports (HOST) Not accessible to User)	-40°C to 105°C
P2	USB power/ Debug Console (2. USB Micro-AB connector 5V Power supply)	-40°C to 105°C
P4	RS232	-25°C to 85°C
P5	Digital Input(0-24v)	-25°C to 85°C
P6	Digital Output(0-24v)	-25°C to 85°C
P7	USB 2.0	-40°C to 105°C
P8	mPCIe (Supports multiple Cellular Modules 2G/3G/4G/Cat-M/NB-IoT, Supports AI & ML VPU/TPU co-processor).	<b>DNM</b>
P9	CAN & RS-485	-25°C to 85°C
P10	Expansion Header	-40°C to 105°C
P11	RTC Battery	-25°C to 85°C
P12	LED GPIO	<b>DNM</b>
P13	Debug port	-40°C to 120°C
P16	LCD Connector	-
P17	ATSAML 11E 16-GPIO Connector	<b>DNM</b>
SW2	Reset	-30°C to 85°C
M1	mikroBUS Expansion (Supports multiple IoT wireless modules (ZigBee/BLE/LoRa/6LoWPAN), Supports multiple IoT Sensor modules based on UART/I2C/SPI Interface)	-40°C to 105°C
U14	ATSAML11E16-A	<b>DNM</b>
U17	ATWILC3000	<b>DNM</b>
J3	Ethernet (RJ45 10/100Mbps )	-40°C to 85°C
J4	SD card + SIM (Dual connector)	-
D3	Power LED	-55°C to 85°C
D4/D7/D17	User Level /RGB tricolour LEDs	-55°C to 85°C

Table 2

### 2.1.1. Connectors and PIN Header

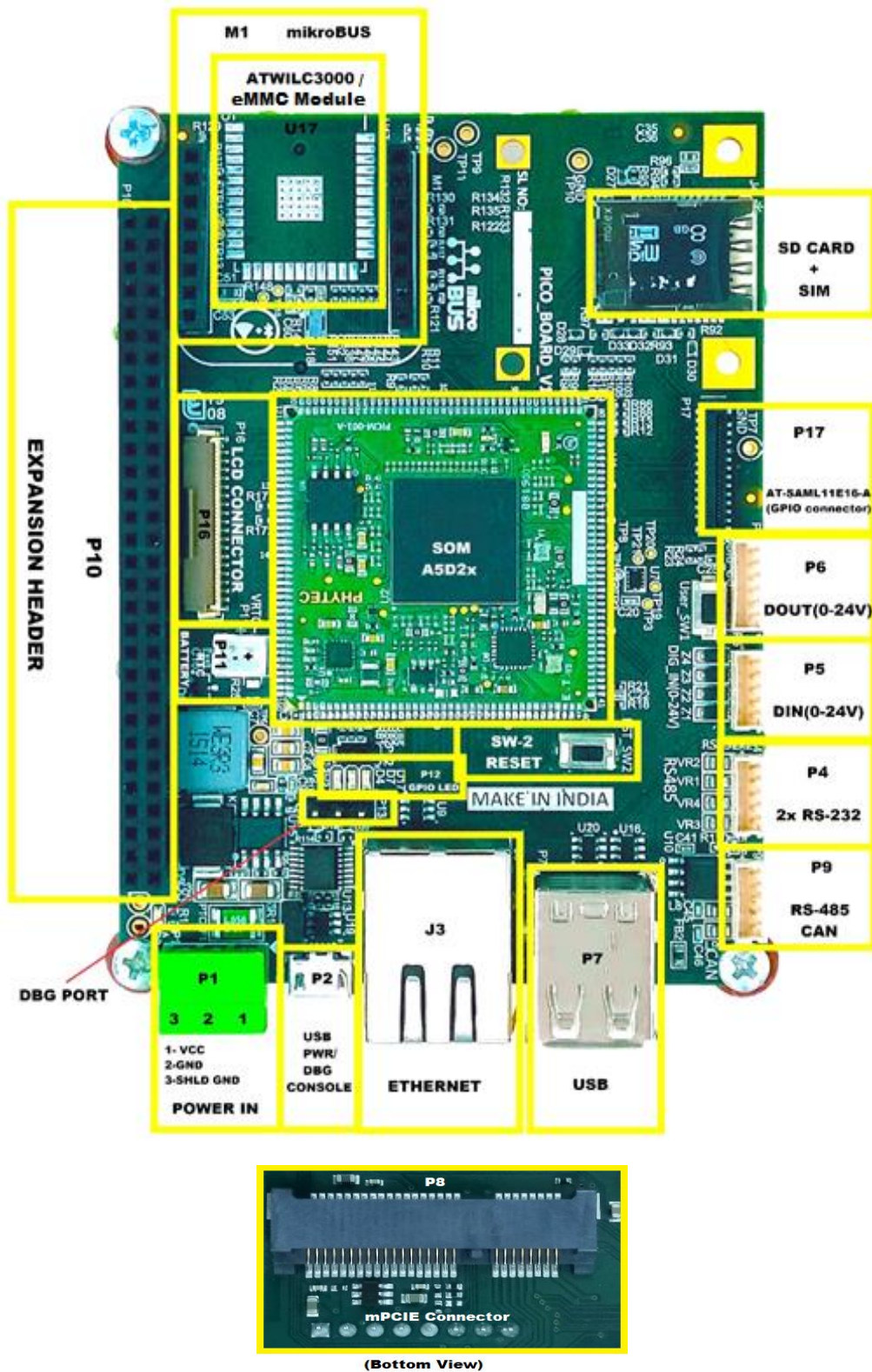

Fig. 1

## 2.1.2. Block Diagram

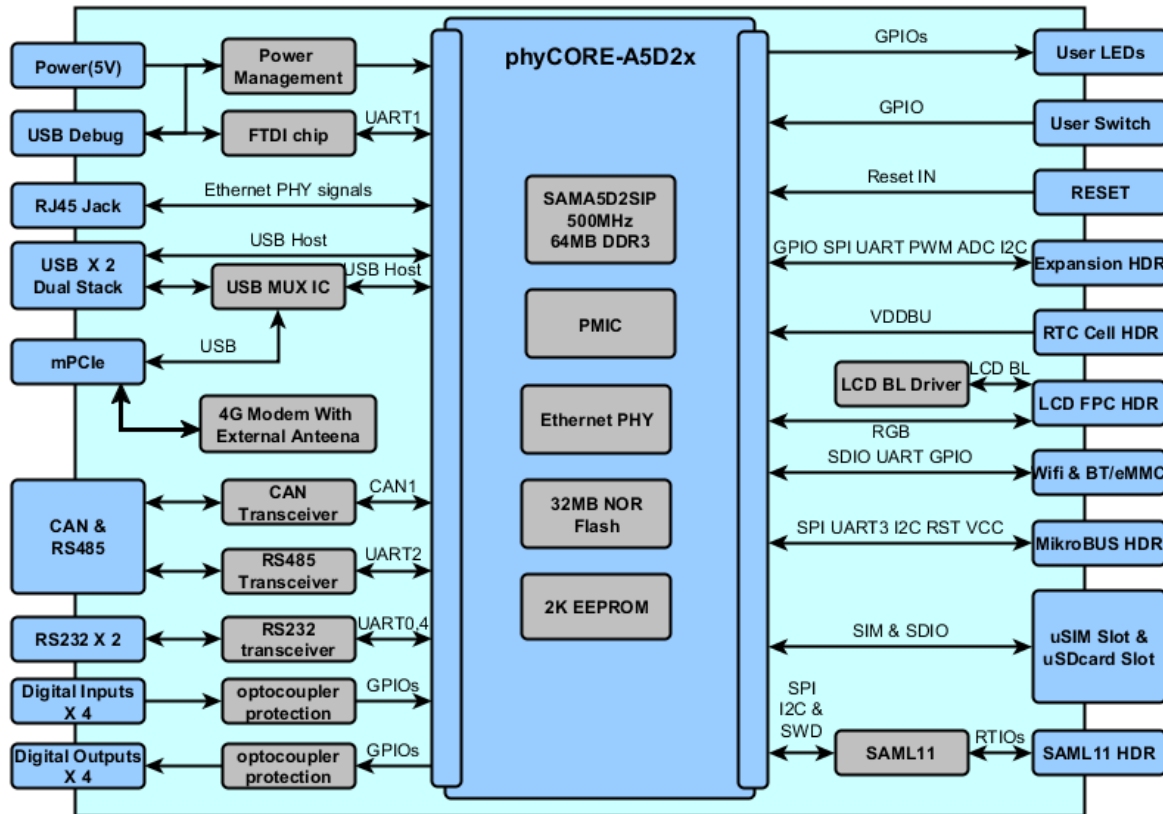

Fig. 2

## 2.2. Functional Components

This section describes the functional components of the Industrial RuggedBOARD (Rugged board). Each subsection details a particular connector/interface and associated jumpers for configuring that interface.

### 2.2.1. Power Supply (P2)

The Industrial ruggedBOARD is available with two different power supply connectors.

### 2.2.1.1 Power IN

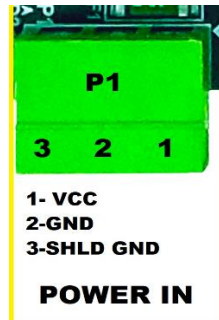

Fig. 3

A 3-pole Phoenix Contact MINI COMBICON base strip 3.5 mm connector (P1) suitable for a single 5 V supply voltage (Fig. 3)

PIN	Description
1	VCC (5V)
2	GND
3	SHLD

Table 3

### 2.2.1.2 USB PWR / DBG CONSOLE



Fig. 4

A USB Micro-AB connector (P2) to connect a standard 5V USB power supply.

(Fig. 4)

PIN NO	SIGNAL NAME	DESCRIPTION
1	DC_IN/USB	VBUS
2	Debug_D_N	DM
3	Debug_D_P	DP
4	ID	ID
5	GND	GND
6 7 8 9 10 11	SH1	SHLD_GND

Table 4

## 2.2.2 Ethernet (J3)

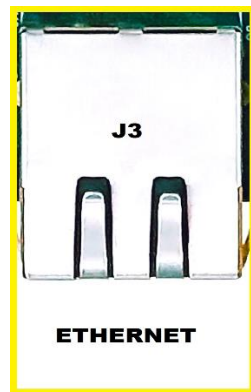

Fig. 5

Ethernet Connectivity (J3) The Ethernet interfaces of the Industrial Pico Computer are accessible at J3. Figure 6: Ethernet Interface at Connector (J3) Ethernet interface is configured as 10/100Base-T networks. The LEDs for LINK (green) and SPEED (yellow) indication are integrated in the connector. Ethernet transceiver support HP Auto-MDIX, they detect the TX and RX pins of the connected device and automatically configure the PHY TX and RX pins accordingly.

PIN NO	SIGNAL NAME	DESCRIPTION
1	ETH_TX_P	TD+
2	ETH_TX_N	TD-
3	ETH_RX_P	RD+
4	Poe_V+/TDCT	PoE_V+
5	Poe_V+/RDCT	PoE_V+
6	ETH_RX_N	RD-
7	Poe_V-/NC	SHLD
8	Poe_V-/CH_GND	PoE_V-
9	LED1-A	
10	LED1-k	
11	LED2-k	ETH_LED0
12	LED2-A	VCC_3V3
13	SHIELD1	SHIELD
14	SHIELD2	SHIELD

Table 5

### 2.2.3 Secure digital Memory card + SIM (Dual Connector) (J4)

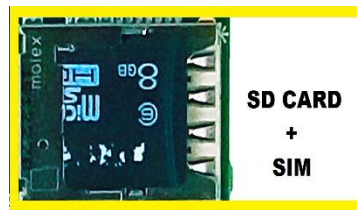

Fig. 6

The Industrial RuggedBOARD provides a standard micro SDHC card slot at J4 for connection to MMC/SD interface cards. It allows easy and convenient connection to peripheral devices like SD and MMC cards. Power to the SD interface is supplied by inserting the appropriate card into the MMC/SD connector which features card detection, a lock mechanism and a smooth extraction function by Push-in/ Push-out of card. DIP switch S4 allows to toggle between NAND boot and boot from SD card.

PIN	SIGNAL NAME	DESCRIPTION
T1	PA20_SDMMC1_DAT2	DAT2
T2	PA21_SDMMC1_DAT3	DAT3
T3	PA28_SDMMC1_CMD	CMD
T4	VCC_3V3	VCC
T5	PA22_SDMMC1_CLK	CLK
T6	GND	GND
T7	PA18_SDMMC1_DAT0	DAT0
T8	PA19_SDMMC1_DAT1	DAT1
SW	PA30_SDMMC1_CD	SW1
C1	SIM_VCC	SIM_VCC
C2	SIM_RST	SIM_RST
C3	SIM_CLK	SIM_CLK
C4	SIM_GND	GND
C5	SIM_VPP	SIM_VPP
C6	SIM_IO	SIM_IO
G1 G2 G3 G4 G5 G6 G7 G8	GND	GND

Table. 6



## 2.2.4 RS-232 (P4)



Fig. 7

Two RS-232 transceivers on the ruggedBOARD convert the TTL level signals of UART0 (the standard console) and UART4 from the phyCOREA5D2X to RS-232 level signals. Serial Port RS232 (Non-Isolated) and with Full Modem (RTS, CTS). 5 Pin Header: Configured as Full Modem / Half Modem.

PIN NO	DESCRIPTION
1	RS232_TX_1
2	RS232_RX_1
3	GND
4	RS232_TX_2
5	RS232_RX_2

Table 7

## 2.2.5 DIN and DOUT(0-24V) (P5 and P6)



Fig. 8



Fig. 9

The Industrial RuggedBOARD comes with an isolated Digital IOs(0-24V). The ruggedBOARD provides four digital IOs that are designed for processing DC-signals with up to 24 V DC. The digital output voltage depends on the input voltage of the board. Input and output signals are routed to the CPU (SAM-A5D2x) through two discrete optocouplers for galvanic isolation. Thus, it is possible to write and read the status of every single GPIO of the ruggedBOARD simultaneously.

 <b>WARNING!</b>	<p>Please consider that the GPIOs do not have a separate current driver on board. In case the GPIOs are used as outputs, the current is self-limited by the output-optocoupler and should not exceed 750mA for each GPIO channel. These outputs are low WARNING! side outputs.</p>
--	--

P5 Connector:

PIN NO	DESCRIPTION
1	DIN(0-24V)_01
2	DIN(0-24V)_02
3	DIN(0-24V)_03
4	DIN(0-24V)_04
5	DGND_ISO_IN

Table 8

P6 Connector:

PIN NO	DESCRIPTION
1	ISO_VCC_IN
2	DOUT(0-24V)_04
3	DOUT(0-24V)_03
4	DOUT(0-24V)_02
5	DOUT(0-24V)_01
6	DGND_ISO_IN

Table 9

## 2.2.6 USB 2.0 (P7)

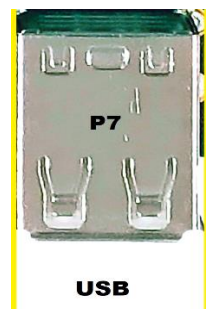

Fig. 10

SIGNAL NAME	DESCRIPTION
VBUS	VBUS_HOST1
DM	USBA_N

DP	USBA_P
GND	GND
VBUS 9	VBUS_HOST2
DM 10	USBD_HOST_N
DP 11	USBD_HOST_P
GND 12	GND

Table.10

### 2.2.7 RS-485 (P9)



Fig. 11

A), EIA-485, is a standard defining the electrical characteristics of drivers and receivers for use in serial communications systems.... Digital communications networks implementing the standard can be used effectively over long distances and in electrically noisy environments.

An RS-485 transceiver on the Industrial ruggedBOARD converts the TTL level signals of UART1 from the SAMA5D2x to RS-485 level signals. The RS-485 level signals are available at the connector P9. Figure shows a detailed view of the P9 connector.

Refer Table from section 2.2.8 for pinout details.

### 2.2.8 CAN (P9)



Fig. 12

The Controller Area Network (CAN) bus offers a low-bandwidth, prioritized message fieldbus for serial communication between microcontrollers. It efficiently supports distributed real time control with a high level of security. The DCAN module of the SAMA5D2x implements the CAN protocol according to the CAN 2.0B protocol specification and supports bit rates up to 1 Mbit/s. The CAN interface of the Industrial ruggedBOARD SAMA5D2x is connected to the CAN-controller DCAN1 of the SAMA5D2x

SOM. The CAN interface of the Industrial ruggedBOARD SAMA5D2x is accessible at the connector P9.

PIN	Description
1	CANH (CAN)
2	CANL (CAN)
3	GND
4	B (RS485)
5	A (RS485)

Table 11

### 2.2.9 Expansion Header (P10)

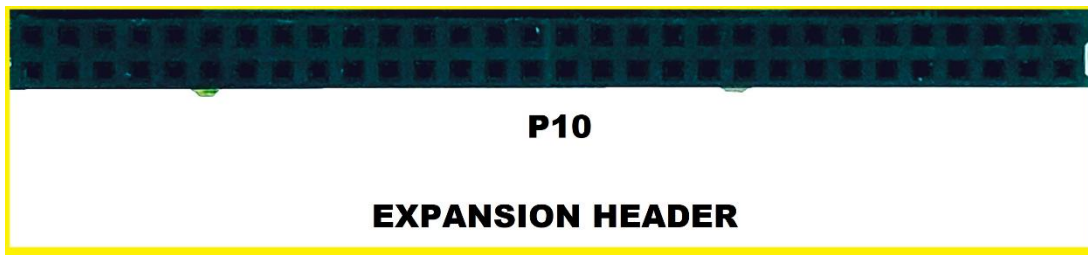

Fig. 13

Expansion connector P10 provides an easy way to add other functions and features to the Industrial ruggedBOARD Standard interfaces such as UART, SPI and I2 C as well as different supply voltages and some GPIOs are available at the expansion female connector. The expansion connector is intended to add specific functions with custom expansion boards.

The pinout of the expansion connector is shown in Table given below:

PIN NO	DESCRIPTION
1	VCC 3V
2	VCC 5V_IN
3	VCC 3V
4	VCC 5V_IN
5	VCC 3V
6	VCC 5V_IN
7	CLK_AUDIO
8	COMPP
9	STROBE
10	COMPN
11	PIOBU6
12	PD19/PCK0/TWD1/AD0
13	PD20/TIOA2/TWCK1/AD1
14	PD30_AIN_SEN4
15	PD27_AIN_SEN2
16	PD28_AIN_SEN3
17	PIOBU4
18	PIOBU3
19	PIOBU2
20	PD26_AIN_SEN1

21	PIOBU1
22	RXD
23	PD08/NANDRDY/PTCROW5
24	PD4
25	PD07/NWR1/NBS1/PTCROW4
26	PD06/PCK1/NCS2/PTCROW3
27	GND
28	GND
29	GND
30	GND
31	PD22_I2SC0_DI0_SCL
32	PD21_I2SC0_WS_SDA
33	DATA
34	PIOBU7
35	PC11/ISI_D2/TCLK4/CANRX0/A0/NBS0
36	PC25/ISI_FIELD/A14
37	PC23/ISI_HSYNC/A12
38	PC18/ISI_D9/FLEXCOM3_IO2/A7
39	PA13/SDMMC0_CD/FLEXCOM3_IO1/D8
40	PA12/SDMMC0_WP/IRQ/NRD/NANDOE
41	PA31/SPI0_MISO/PWML0/CLASSD_L3
42	SHDN
43	PA29/TCLK1/SPI0_NPCS1/SDMMC1_WP/CLASSD_L1
44	PA14/SPI0_SPCK/TK1/QSPI0_SCK/I2SMCK1/FLEXCOM3_IO2/D9
45	PC31/FLEXCOM4_IO3/URXD3/A20
46	PC16/ISI_D7/RK0/A5
47	PB09/TIOA3/PWMFI1/QSPI1_IO2
48	PB07/TIOB2/PWMH3/QSPI1_IO0
49	GND
50	GND
51	PB05/TCLK2/PWMH2/QSPI1_SCK
52	PB10/TIOB3/PWMEXTRG1/QSPI1_IO3
53	PB08/TCLK3/PWML3/QSPI1_IO1
54	VLED+
55	nRST
56	VLED+
57	GND
58	GND
59	GND
60	GND

Table 12

### 2.2.10 RTC Battery (P11)



Fig. 14

**Real-time clock(RTC)** is a (most often in the form of an) that keeps track of the current.

The Industrial ruggedBOARD uses RTC for real-time or time driven applications. Please note that if the RTC's interrupt is needed, at expansion connector P11 need to be shortcut (section 3.1). The Industrial ruggedBOARD is equipped with a Gold Capacitor (placed next to connector P11) which is also intended to back up the external RTC.

PIN No.	Description
1	VCC 3V
2	GND

Table 13

### 2.2.11 User LED GPIO (D17, D7, D4)



Fig. 15

LED GPIO (P12) as shown in the above figure, consists of D17, D7, D4

The Industrial ruggedBOARD is populated with Three LEDs to indicate the status of the USB VBUS voltages, the power supply voltages, and the RUN/STOP and ERROR. Figure 15 shows the location of the LEDs. Their functions are listed in Table given below.

PIN NO	LED	Description
3	D17	RGB LED(GPIO_LED)
2	D7	RGB LED(GPIO_LED)
1	D4	RGB LED(GPIO_LED)
4	VCC_3V3	

Table 14

### 2.2.12 DBG PORT (P13)



Fig. 16

**Debug port** is a **port** included in a device to simplify development and **debugging** which is not necessary for normal functioning of it. **Debug ports** are usually not removed or disabled.

Debugging facility is also available in Micro USB connector P2.

The table below shows the pin description:

PIN No	Description
1	PD2_URXD1_DBG
2	PD3_UTXD1_DBG
3	GND

Table 15

### 2.2.13 LCD Connector (P16)

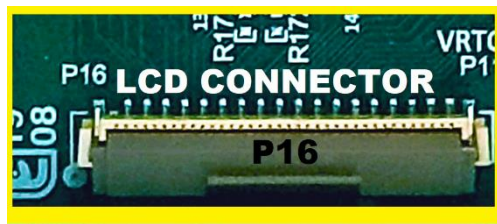

Fig. 17

Meanwhile there are a few LVDS displays on the market with kind of standardized interfaces. In the following table is a complete overview of the LVDS display connector pin assignment.

PIN No.	DESCRIPTION
1	PC4_SAM_SPI1_NPCS0
2	PC05/LCDVSYNC/TCLK1/SPI1_NPCS1/I2SDO0
3	PC08/LCDDEN/FIQ/PCK0/UTXD1
4	PC07/LCDPCK/TWCK1/SPI1_NPCS3/URXD1
5	PC06/LCDHSYNC/TWD1/SPI1_NPCS2
6	PC1_SAM_SPI1_SPCK/LCDDAT22
7	PC3_SAM_SPI1_MISO
8	PC00/LCDDAT21/FLEXCOM0_IO4
9	PB31/LCDDAT20/FLEXCOM0_IO3
10	PB29/LCDDAT18/FLEXCOM0_IO1/TIOB5

11	PC2_SAM_SPI1_MOSI/LCDDAT23
12	PB11_URXD3/LCDDAT0
13	PB14/LCDDAT3/TK1/I2SMCK1
14	PB12_UTXD3/LCDDAT1
15	PB18/LCDDAT7/RK1/I2SDO1
16	PB16_I2SC1_WS
17	PB20/LCDDAT9/TK0/TIOB3/PCK1
18	PB19/LCDDAT8/RF1/TIOA3
19	PB25/LCDDAT14/RF0/FLEXCOM3_IO4
20	PB13/LCDDAT2/PCK1
21	PB17_I2SC1_DI0_GPIO
22	PB22/LCDDAT11/TD0/TIOA2/FLEXCOM3_IO1
23	PB23/LCDDAT12/RD0/TIOB2/FLEXCOM3_IO0
24	PB15/LCDDAT4/TF1/I2SCK1
25	PB27_UTXD0/LCDDAT16
26	PB21/LCDDAT10/TF0/TCLK3/FLEXCOM3_IO2
27	PB30/LCDDAT19/FLEXCOM0_IO2/TCLK5
28	PB28/LCDDAT17/FLEXCOM0_IO0/TIOA5
29	PB24/LCDDAT13/RK0/TCLK2/FLEXCOM3_IO3
30	PB26_URXD0/LCDDAT15
31	PD22_I2SC0_DI0_SCL
32	PD21_I2SC0_WS_SDA
33	VCC_3V3
34	GND
35	VCC_3V3
36	GND

Table 16

### 2.2.14 mPCIe Connector (P8)

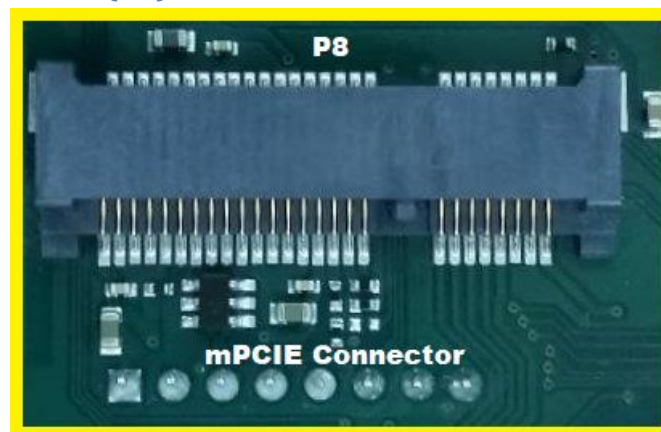

Fig. 18

The mPCIe interface is brought out at the Mini PCIe connector. The SIM/UIM card signals of a connected mPCIe module can be made available at expansion connector J4. Please refer to Table for more information about the jumper settings. Soldering jumpers allow to connect the USB host interface to the Mini PCIe connector P8 (Table 17). In the following table is a complete overview of the Mini PCI Express connector pin Assignment:



<b>PIN NO</b>	<b>SIGNAL NAME</b>	<b>DESCRIPTION</b>
1	WAKE	VCC_3V3
2	+3.3V_1	VCC_3V3
3	RSVD1	
4	GND7	GND
5	RSVD2	
6	+1.5V_1	
7	CLKREQ	
8	RSVD13	SIM_VCC
9	GND1	GND
10	RSVD14	SIM_IO
11	REFCLK-	
12	RSVD15	SIM_CLK
13	REFCLK+	
14	RSVD16	SIM_RST
15	GND2	GND
16	RSVD17	SIM_VPP
17	RSVD3	
18	GND8	GND
19	RSVD4	
20	RSVD18	VCC_3V3
21	GND3	GND
22	PERST	PA11/GPIO_RST_GSM
23	PER_N0	
24	+3.3V_AUX	VCC_3v3
25	PER_P0	
26	GND9	GND
27	GND4	GND
28	+1.5V_2	
29	GND5	GND
30	SMB_CLK	
31	PET_N0	
32	SMB_DATA	
33	PET_P0	

34	GND10	GND
35	GND6	GND
36	USB_D-	USB_mPCIe_N
37	RSVD5	GND
38	USB_D+	USB_mPCIe_P
39	RSVD6	VCC_3V3/GND
40	GND11	GND
41	RSVD7	VCC_3V3/GND
42	LED_WWAN	VCC_3v3
43	RSVD8	GND
44	LED_WLAN	
45	RSVD9	
46	LED_WPAN	
47	RSVD10	
48	+1.5V_3	
49	RSVD11	
50	GND12	GND
51	RSVD12	
52	+3.3V_2	VCC_3V3/GND
S1	GNDM1	GND
S2	GNDM1	GND
M1	GNDM3	GND
M2	GNDM4	GND

Table 17

### 2.2.15 ATWILC3000 (U17) - [Optional Mount]

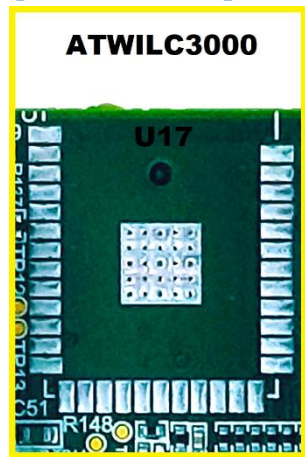

Fig. 19

ATWILC3000 is a single chip IEEE 802.11 b/g/n RF/Baseband/MAC link controller and Bluetooth 5. The ATWILC1000 connects to Microchip AVR/SMART MCUs, SMART MPUs, and other processors with minimal resource requirements with simple SPI/SDIO-to-Wi-Fi and UART-toBluetooth interfaces.

The ATWILC3000 supports single stream 1x1 802.11n mode providing tested throughput of up to 46 Mbps UDP & 28 Mbps TCP/IP. The ATWILC3000 features fully integrated Power Amplifier, LNA, Switch and Power Management. Implemented in low-power CMOS technology, the ATWILC3000 offers very low power consumption while simultaneously providing high performance and minimal bill of materials.

The ATWILC3000 utilizes highly optimized 802.11-Bluetooth coexistence protocols. The only external clock sources needed for the ATWILC3000 is a high-speed crystal or oscillator and a 32.768 kHz clock for sleep operation. □ IEEE 802.11 b/g/n 20MHz (1x1) Wi-Fi plus Bluetooth 5 Low Energy Module Supports Personal & Enterprise IEEE 802.11 WEP, WPA, WPA2 Security, SPI, SDIO, I2C, and UART host interfaces Operating temperature range of -40C to +85C Bluetooth 5 Certified Module is Agency Certified in over 75 Countries.

PIN NO	SIGNAL NAME	DESCRIPTION	PIN OF PROCESSOR
1	GND	GND	1
2	GND/SDIO MODE	SDIO/SPI_CFG	2
3	NC		3
4	NC		4
5	NC		5
6	NC		6
7	A26/GPIO_PRST_WIFI	RESETN	7
8	PB11_URXD3/LCDDAT0	BT_TXD	8
9	PB11_URXD3/LCDDAT1	BT_RXD	9
10	TP12	BT_RTS	10
11	TP13	BT_CTS	11
12	VCC_3V3	DVDDIO	12
13	GND	GND	13
14	GPIO3		14
15	GPIO4		15
16	TP14	UART_TXD	16
17	TP15	UART_RXD	17
18	VCC_3V3	VBAT	18
19	PD5/WIFI_GPIO_EN	CHIP_EN	19

20	ASH7KW(OUT)	RTC	20
21	GND	GND	21
22	PA0_SDMMC0_CK	SD_CLK/GPIO8	22
23	PA1_SDMMC0_CMD	SD_CMD/SPI_CLK	23
24	PA2_SDMMC0_DAT0	SD_DATA0/SPI_MISO	24
25	PA3_SDMMC0_DAT1	SD_DAT1/SPI_SSN	25
26	PA4_SDMMC0_DAT2	SD_DAT2/SPI_MOSI	26
27	PA5_SDMMC0_DAT3	SD_DAT3/GPIO7	27
28	GND	GND	28
29	GPIO17		29
30	GPIO18		30
31	GPIO19		31
32	GPIO20		32
33	PA25_WIFI_INRPT	IRQN	33
34	TP11	I2C_SDA_M	34
35	TP9	I2C_SCL_M	35
36	GND	GND	36
37	GND	PADDLE	37

Table 18

### 2.2.16 mikro-BUS Connector (M1)

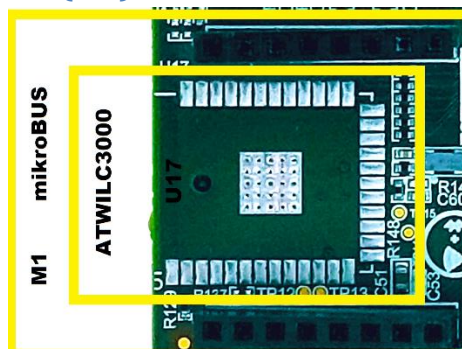

Fig. 20

All Industrial pico- computer has many dual row, 20-pin, 100-mil extension headers. The Industrial ruggedBOARD have male headers, while the explained Pro-extensions have their female counterparts. The following table provides the pin description of all the connected pins. Info: Not all pins are always connected on all extension headers. The extension headers can be used to connect a variety of Add-On modules to Industrial ruggedBOARD or to access the pins of the target microcontroller on the Industrial RuggedBOARD.

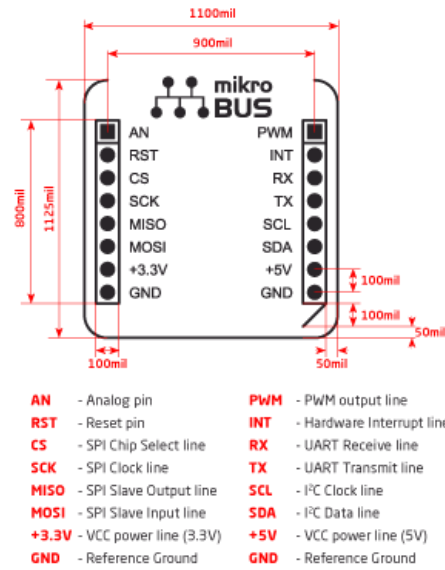

Fig. 21

PIN NO	SIGNAL NAME	DESCRIPTION
01	PD25_AN_mBUS1	AN
2	PB2_RST_mBUS1	RST
3	PD0_NPCS1_mBUS	CS
4	PC30_SPCK_mBUS1	SCK
5	PC29_MISO_mBUS1	MISO
6	PC28_MOSI_mBUS1	MOSI
7	VCC_3V3	3V
8	GND	GND
9	GND	GND
10	VCC5V_IN	5V
11	PD21_I2SC0_WS_SDA	SDA
12	PD22_I2SC0_DI0_SCL	SCL
13	PB11_URXD3/LCDDAT0	TX
14	PB12_UTXD3/LCDDAT1	RX
15	PB00_INT_mBUS1	INT
16	PB01_PWM_mBUS1	PWM

Table 19

### 2.2.17 Real Time Clock Module with I<sup>2</sup>C-Bus

The RV-4162-C7 is a SMT Real-Time Clock Module that incorporates an integrated CMOS circuit together with an XTAL. It operates under vacuum in a hermetically sealed ceramic package with metal lid.

The testing process of RTC and EEPROM with I<sup>2</sup>C Bus is shown below:

\*\*\*\*\*

RTC testing:

\*\*\*\*\*

```
root@phyboard-regor-am335x-1:~# date 032315432019.22
```

```
Sat Mar 23 15:43:22 UTC 2019
```

```
root@phyboard-regor-am335x-1:~# hwclock -w -f /dev/rtc0
```

```
root@phyboard-regor-am335x-1:~# hwclock -r -f /dev/rtc0
```

```
Sat Mar 23 15:43:35 2019 0.000000 seconds
```

```
root@phyboard-regor-am335x-1:~#
```

```
root@phyboard-regor-am335x-1:~#
```

```
root@phyboard-regor-am335x-1:~#
```

```
root@phyboard-regor-am335x-1:~# date
```

```
Sat Mar 23 15:43:39 UTC 2019
```

```
root@phyboard-regor-am335x-1:~# date
```

```
Sat Mar 23 15:44:31 UTC 2019
```

```
root@phyboard-regor-am335x-1:~# after reboot
```

```
-sh: after: command not found
```

```
root@phyboard-regor-am335x-1:~# date
```

```
Sat Mar 23 15:44:38 UTC 2019
```

```
root@phyboard-regor-am335x-1:~#
```

.....

EEPROM testing:

\*\*\*\*\*

```
echo ganesh > /sys/class/i2c-adapter/i2c-2/2-0050/eeprom
```

```
cat /sys/class/i2c-adapter/i2c-2/2-0050/eeprom
```

```
ganesh
```

.....

### 2.2.18 POWER CONSUMPTION TABLE

Peripherals	TEST Scenario	Current Consumption
Board	While booting with SD card	90mA
USB Slot	Tested with Pen drive	130 mA
Ethernet	Tested connecting board to HOST system	110 mA
RTC battery		100mA
CAN	PCAN	TBD
RS485	Tested using phyBOARD Regor	TBD
DIN (5V)		100mA
DOUT (5V)		100mA
mikroBUS		TBD
GPIOs		TBD

Table 20

