

---

# Secure Console Servers

## SCS, SCS-R and Sentinel Models Product Manual



***thinklogical***<sup>tm</sup>  
Extend • Distribute • Innovate

Thinklogical™ Inc.  
100 Washington Street  
Milford, Connecticut 06460 U.S.A.

Telephone: 1-203-647-8700  
Fax: 1-203-783-9949  
[www.thinklogical.com](http://www.thinklogical.com)

Revision J

---

## **Copyright Notice**

Copyright ©2010. All Rights Reserved. Printed in the U.S.A.

**Thinklogical™, a subsidiary of Logical Solutions, Incorporated**  
**100 Washington Street**  
**Milford, Connecticut 06460 U.S.A.**  
**Telephone: 1-203- 647-8700**

*All trademarks and services marks are property of their respective owners.*

Appendix C copyright ©2003, by Multi-Tech Systems, Inc.

**Subject:** SCS80 / SCS1 60 / SCS320 / SCS480 / SCS80R /  
SCS1 60R / SCS320R / SCS480R / Sentinel 32

**Revision:** J, December 2010.

## SCS, SCS-R and Sentinel 32 Product Manual

### TABLE OF CONTENTS

<b>PREFACE (Notes &amp; Warnings)</b>	<b>7</b>
<b>1. Introduction</b>	<b>7</b>
1.1 SCS Models Covered in this Manual	8
1.2 System Features	11
1.3 Software Features	11
1.4 Hardware Features	12
1.4.1 SCS80R, SCS160R, and SCS320R Hardware	12
1.4.2 SCS480R Hardware	12
1.4.3 Sentinel 32 Hardware	13
1.5 Technical Specifications	14
1.6 Documentation	14
<b>2. Product Overview</b>	<b>15</b>
2.1 Intended Application	15
2.2 System Chassis	16
2.2.1 SCS80 / SCS160 / SCS320 / SCS480	16
2.2.2 SCS80R / SCS160R / SCS320R / SCS480R	16
2.2.3 Sentinel 32	16
2.3 Connecting to the SCS	16
2.3.1 Serial Devices	17
2.3.1.1 Break Safe	17
2.3.2 IP Network	17
2.3.3 AC Power	18
2.3.3.1 SCS80 / SCS160 / SCS320 / SCS480	18
2.3.3.2 SCS80R / SCS160R / SCS320R / Sentinel 32	18
2.3.3.3 SCS480R	18
2.3.4 DC Power	18
2.4 User Access Control	18
2.4.1 User Sessions	19
2.5 Port buffers	19
2.5.1 How to Disable Buffering	19
<b>3. Installation</b>	<b>19</b>
3.1 Mounting the SCS	19
3.1.1 Rack Mount or Desktop	19
3.1.2 Front Panel Display and Buttons	20
3.1.3 Convection Cooled	20
3.2 Connections	20
3.2.1 Power	22
3.2.2 AC Input	22
3.2.3 Connecting to the Network Port	22
3.2.3.1 SCS-R and Sentinel 32 Dual NIC Interface	22
3.2.4 Connect your Console	23
3.2.4.1 SCS-R and Sentinel 32 Dual Console Interface	23
3.2.5 Connect to the Ports	23
3.2.5.1 Automated Port Configuration Tests	24

3.2.5.2 Port Adapters	24
3.2.5.3 Serial Port Pin-out	24
3.3 SCS-R and Sentinel Power Modules	25
3.3.1 Power Module Replacement	25
3.4 SCS-R and Sentinel -48VDC Power Modules	26
3.4.1 Wiring the -48VDC Connector	27
3.4.2-48VDC Power Module Replacement	28
<b>4. Initial Configuration</b>	<b>29</b>
4.1 Default Configuration	29
4.2 Initial System Security Concerns	29
4.3 Front Panel Network Setup	29
4.3.1 Front Panel Edit Mode	29
4.3.1.1 Start Front Panel Edit Mode	30
4.3.1.2 Program Network	30
4.4 Initial Connection via Network	35
4.4.1 Network Connection Requirements	35
4.4.2 Route via Linux Workstation	35
4.4.3 Route via Windows Workstation	35
4.5 Initial Connection via Console port	37
4.6 How to Access the LSI SCS Web Setup Interface	37
<b>5. System Overview</b>	<b>37</b>
5.1 SCS Systems are Linux-based	37
5.1.1 Linux General Public License	37
5.1.3 SCS System Architecture	38
5.2 Initial System Administrator (sysadmin) Access	38
5.2.1 Enter Commands	38
5.2.2 Log Out	38
5.3 Default Services	38
5.3.1 Configure the Services	39
<b>6. Commands</b>	<b>40</b>
6.1 System Commands	40
6.1.1 save	40
6.1.2 reboot	40
6.1.3 power off	41
6.1.4 Other Linux Commands	41
6.2 Change Logging Level	43
<b>7. System Administration</b>	<b>43</b>
7.1 Security	43
7.2 Change Network Address	43
7.2.1 Run netconfig	43
7.2.1.1 Save your netconfig changes	44
7.2.2 More Than One Nameserver	45
7.3 Change Hostname	45
7.4 Time Configuration	45
7.5 Change NIC Speed	45
7.6 Configure Authentications	46
7.7 Front Panel Display Options	46
7.7.1 Display Mode Parameters	47

7.7.1.1 Edit	47
7.7.1.2 View	47
7.7.1.3 LINE_1=	47
7.7.1.4 LINE_2=	47
7.7.1.5 Display OFF	48
7.8 Network Time Service	48
7.8.1 Configure NTP	48
7.8.2 Start the NTP Service	48
7.9 NIS and User Port Permissions	48
7.9.1 User Port Control	49
7.9.2 NIS Port Access	49
7.9.3 User Names and Groups	50
7.9.4 NIS Database file	50
7.9.5 NIS Make file	50
7.9.6 NIS Configuration File	51
7.10 NFS	51
7.10.1 Remote NFS Directory	51
7.11 SNMP	52
7.11.1 Start SNMP	52
7.12 syslog	52
7.13 Timeouts	52
7.14 Changing Serial Port Settings	52
7.14.1 Disable Buffering while in Interactive	53
<b>8. Administering Users</b>	<b>53</b>
8.1 User Setup	53
8.1.1 adduser	53
8.1.2 edituser	54
8.1.3 deluser	54
8.1.4 Other Editing Commands	54
8.1.4.1 editbrk <name>	54
8.1.4.2 editesc <name>	54
<b>9. User Operations</b>	<b>55</b>
9.1 User Accounts	55
9.1.1 SCS users	55
9.1.2 root user	55
9.2 Port Identities	55
9.3 What Users Can Do	55
9.3.1 Access via Network	55
9.3.1.1 Secure Shell Host (ssh) to a Port	55
9.3.2 Access via console port	55
9.3.3 Interactive Mode	55
9.3.3.1 Break Sequence	55
9.3.3.2 Escape Sequence	56
9.4 Monitor Mode	56
9.5 Browse the buffers	56
9.6 Clear the Port buffers	57

<b>10. Regulatory &amp; Safety</b>	<b>57</b>
10.1 Safety Requirements	57
10.1.1 Symbols found on the Product	57
10.2 Regulatory Compliance	57
10.2.1 North America	57
10.2.2 European Union	57
10.2.2.1 Declaration of Conformity	57
10.2.2.2 Standards to Which Our Products Comply	58
10.2.2.3 Supplemental Information	58
10.3 Product Serial Number	59
10.4 Lithium Battery	59
10.5 SCS-R Models and Sentinel 32 Power Modules	59
<b>11. How to Contact Us</b>	<b>59</b>
11.1 Customer Support	59
11.1.1 Website	60
11.1.2 E-mail	60
11.1.3 Telephone	60
11.1.4 Fax	61
11.2 Product Support	61
11.2.1 Limited Warranty Information	61
11.2.2 Our Address	62
<b>APPENDICES</b>	
<b>A</b> File System	63
<b>B</b> FAQ	64
<b>C</b> Sentinel 32 Modem Commands	65
<b>D</b> DC Power	86
<b>E</b> Assigning IP Addresses to a Device Port	88
<b>F</b> Adapter Pin-outs	88
<b>G</b> Quick Start Guide	93

## PREFACE

### NOTES and WARNINGS

As you read this manual you will notice certain highlighted conventions that bring your attention to important information. These are **Notes** and **Warnings**. Be sure to read each highlighted note and warning before proceeding. Examples are shown below.



**Note:** Important Notes appear in blue text preceded by a yellow exclamation point symbol, like this.

A note is meant to call the reader's attention to helpful information at a point in the text that is relevant to the subject being discussed.



**Warning!** All Warnings appear in red text preceded by a red stop sign, like this.

A warning is meant to call the reader's attention to critical information at a point in the text that is relevant to the subject being discussed.

**BEFORE STARTING ANY PROCEDURE, IT IS RECOMMENDED THAT YOU READ THE INSTRUCTIONS THOROUGHLY BEFORE PROCEEDING.**

## 1. Introduction

This document pertains to the **Secure Console Server (SCS)** line of products developed and built by Thinklogical<sup>™</sup>, Inc. of Milford, Connecticut, USA and covers the installation, configuration and operation of all SCS models. This document also covers User and Administrator Operations, Regulatory & Safety Requirements and Customer Support information.

## 1.1 SCS Models Covered in this Manual

All Thinklogical<sup>™</sup> Secure Console Server (SCS) models covered in this manual are similar in physical appearance, setup and functionality.



- **SCS80** - 8-Port 1U Secure Console Server



- **SCS160** - 16-Port 1U Secure Console Server



- **SCS320** - 32-Port 1U Secure Console Server





- **SCS480** - 48-Port 1U Secure Console Server

The **SCS80R**, **SCS160R**, **SCS320R** and **SCS480R** models are designed with dual hot-swappable Power Modules which operate redundantly and two network ports and console port connections. The 'R' models are otherwise very similar to the SCS80, SCS160 and SCS320.



- **SCS80R** - 8-Port 1U Redundant Power, Secure Console Server



- **SCS160R** - 16-Port 1U Redundant Power, Secure Console Server



- **SCS320R** - 32-Port 1U Redundant Power, Secure Console Server



- **SCS480R** - 48-Port 1U Redundant Power, Secure Console Server

The **Sentinel 32** model is also designed with dual hot-swappable redundant Power Modules. In addition, the Sentinel 32 offers field replaceable, modular eight-port circuit cards, modular network and console port connections, and an analog modem option.



- **Sentinel 32** - 32-Port 1U Modular, Redundant Power, Secure Console Server

## International Models

The following SCS models are available for International customers and are shipped with regionally appropriate power cord sets. Otherwise, each international model is similar to the domestic **SCS80 / SCS160 / SCS320 / SCS480 / SCS80R / SCS160R / SCS320R / SCS480R** and **Sentinel 32** models.

- **SCS801** - 8-Port 1 U Secure Console Server, International
- **SCS1601** - 16-Port 1U Secure Console Server, International
- **SCS3201** - 32-Port 1 U Secure Console Server, International
- **SCS4801** - 48-Port 1 U Secure Console Server, International
- **SCS801R** - 8-Port 1 U Redundant Power Secure Console Server, International
- **SCS1601R** - 16-Port 1 U Redundant Power Secure Console Server, International
- **SCS3201R** - 32-Port 1 U Redundant Power Secure Console Server, International
- **SCS4801R** - 48-Port 1 U Redundant Power Secure Console Server, International
- **Sovereign 32** - 32-Port 1 U Modular, Redundant Power Secure Console Server, International

## 1.2 System Features

*Each SCS system includes the following features:*

- Linux operating system and command set
- Connections for up to 16, 32 or 48 EIA-232 serial console ports
- 10 baseT/100 baseTX network compatibility
- Pre-configured from the factory: User ready, right from the box
- Open **secure shell host** (ssh)
- NFS and NIS support
- ssh to a Serial Port support
- Break Safe - No undesired “break” signals are sent to connected servers.

*The **SCS-R** models also offer the following additional features:*

- Dual Hot-Swappable, Redundant Power Modules
- Dual 10 baseT/100 baseTX Network Port interfaces
- Dual console port interfaces (one DTE, one DCE)
- Power Monitoring with Module outage notification

*The **Sentinel 32 and Sovereign 32** include the all features of the **SCS-R** models **plus:***

- Hot-swappable, modular console/network and serial port circuit cards
- Optional analog modem in place of the second console port.

## 1.3 Software Features

**All SCS Models are designed with network administrators in mind. No special administration tools, training or procedures required. You know Linux, we run Linux.**

- Open-source Linux Operating System (Red Hat compatible).
- Proprietary SCS features command-line options that follow the standard Linux / UNIX command formats for ease of administration.
- Factory pre-configured to be operational out-of-the-box.

The SCS line allows up to 250 simultaneous user sessions to access up to 48 serial ports. The attached components may be any variety of network center servers, workstations or other devices with a serial port that must be monitored.

## 1.4 Hardware Features

SCS systems mount in industry-standard 19-inch equipment racks or can be placed on a shelf or table top. Each SCS operates independently and is accessible using a secure network connection or a local serial terminal (setup by your **System Administrator** or “**sysadmin**”).

- Rack-mount (19 inch), 1U tall (1.75 in./ 4.5 cm) metal chassis
- 16, 32 or 48 serial ports (CAT5 cables with RJ45 connectors)
- Front panel LCD with push buttons for network setup
- 10/100 BaseT Network Port
- Console port (CAT5 cables with RJ45 connectors)
- Universal AC power input (100-240V, 50/60 Hz)
- Convection cooling
- 256KB-per-port Buffer for Port data

**The SCS can help troubleshoot your networking environment.** The SCS is a "listening" system that monitors messages (ASCII data, server error information, etc.) from the serial ports of the device to which each Port is connected. The SCS captures the data by writing it to a port buffer that can hold 256K bytes of data per port. This buffered data gives the sysadmin a history of console port messages that can be reviewed for troubleshooting a connected device. Having access to the console port messages can make problems easier to identify, minimizing downtime. **In most cases the sysadmin can save the buffered data from each port buffer to another server (e.g., via NFS) in your network.** *This is important to note because the Port data (buffered) is stored in RAM and will be lost if the SCS is powered down.*



**NOTE: Console port messages are stored in RAM and will be lost when the SCS is powered down.**

### 1.4.1 SCS80R, SCS160R and SCS320R Hardware

The **SCS80R**, **SCS160R**, and **SCS320R** models offer hardware redundancy for power, network and console ports. Features include dual NIC inputs, dual console port inputs and hot-swappable Power Modules with discrete inputs. This allows the customer to use redundant power sources with the SCS system and, if necessary, can be field-replaced. Power supply status alerts the system administrator in the event of a power failure from one of the power supplies.

### 1.4.2 SCS480R Hardware

The **SCS480R** offers redundant, hot-swappable, front-panel-accessible power supplies, dual NIC interfaces, dual console ports and 48 serial ports.

### 1.4.3 Sentinel 32 Hardware

The Sentinel 32 offers redundant power supplies as described in Section 1.4.1. The dual network and console ports are also field replaceable. A **dual network/console/modem module** is available which replaces the second console port with an **analog modem**. In addition, the Sentinel uses **hot-swappable circuit modules that allow for field replacement of groups of eight serial ports** without affecting the other ports.

#### Sentinel 32 modules:



*Console/Network Module*



*Console/Network/Modem Module*



*8 Port Interface Module*

## 1.5 Technical Specifications

Each Thinklogical™ SCS system is designed to the following specifications:

<b>User Interface</b>	Linux command-line access via ssh or local console port. Backlit 2-line front-panel LCD display showing network configuration. Five front-panel push buttons with UI for network setup.
<b>Serial Interface (Ports)</b>	SCS80/SCS80R = <b>8 Ports</b> ; SCS160/SCS160R = <b>16 Ports</b> ; SCS320/SCS320R/Sentinel 32 = <b>32 Ports</b> ; SCS480/SCS480R = <b>48 Ports</b> . RJ45-type 8-conductor connector (DTE or DCE; software selectable). Software selectable data rate from 300-115K Baud. Software selectable EIA-232 parameters. 256KB FIFO Buffer in RAM (per Port).
<b>Serial Interface (Console)</b>	80/160/320/480: RJ45-type 8-conductor connector (DCE configuration) 80R/160R/320R/Sentinel 32: Dual RJ45-type 8-conductor connector - one DTE, one DCE Software selectable data rate from 300-115K Baud Software selectable EIA-232 parameters
<b>Network interface (Network)</b>	80/160/320/480: 10/100 BaseT RJ45 8-conductor Ethernet 80R/160R/320R/480R/Sentinel 32: Dual 10/100 BaseT RJ45 8-conductor Ethernet TCP/IP
<b>Modem</b>	A V.92 analog modem is available as an option with the Sentinel 32 for those users who require a connection over a telephone network
<b>CPU &amp; Memory</b>	AMD SC520 CPU, operating at 133MHz. 256MB Compact Flash (CF) memory (non-volatile). 128MB RAM for real time use.
<b>Power Supply</b>	Universal AC Power Input, 100-240VAC, 50/60 Hz, 0.5A each input IEC-type regional cord set(s) included. "R" Models are also available with a -48VDC Power Supply option.
<b>Dimensions</b>	1U: 1.75" H x 17.25" W x 14.75" D (4.5cm x 43.8cm x 37.5cm)
<b>Weight</b>	4.5 kg (10 lbs)
<b>Temperature</b>	Operating: 0° to 50°C (32° to 122°F), 30-90% RH, non-condensing Storage: -20° to 70°C (-4° to 158°F), 10-90% RH, non-condensing
<b>Relative Humidity</b>	Operating: 10- 90% non-condensing (40-60% recommended) Storage: 10-90% non-condensing

## 1.6 Documentation

The SCS comes with the standard Linux manual pages (hereafter referred to as "man pages") installed; English is the default language, but several other language versions (including German, French & Italian) are also available.

While this manual gives a brief description of some LSI programs, the SCS contains the latest man pages for the LSI programs, scripts and configuration files. If the man page conflicts with this manual, the man page should be followed. Therefore, the SCS is the primary source for software documentation, not the manual. We make every effort to keep the manual current, but if you find a discrepancy, please let us know.

If 'standard' Linux programs (sty is one) are modified by LSI, the corresponding man pages will reflect the changes.

Selected Linux HOWTOs and READMEs can be found at `/usr/local/doc`. More documentation can be found at [www.tldp.org](http://www.tldp.org).

## 2. Product Overview

*Optimize your System Administration and Network Resources*

### 2.1 Intended Application

Thinklogical™ Secure Console Servers are used to securely monitor and centrally manage up to 48 of your networking systems (servers, routers, switches, etc.). They do so by monitoring the console port of your network center's devices and systems. Each attached component must have an EIA-232 compatible serial port. The SCS80 and SCS80R support **8 ports**, SCS160 and SCS160R support **16 ports**, SCS320, SCS320R, and Sentinel 32 support **32 ports** and the SCS480 and SCS480R support **48 ports**. Security is maintained through encryption and user passwords.

The SCS80R, SCS160R, SCS320R, SCS480R, and Sentinel 32 systems are used where redundant power concerns exist, where hot-swap replacement of Power Modules is a concern or where more than one network connection or console port connection is required.

User accounts are set up by the root user, or sysadmin of the SCS. A user can access the attached servers using commands from a local terminal or through an ssh-protocol (secure) network connection. In order to interact with a device the user must have **read, review** or **write** access to that port.

Users can interact with each of the attached devices by logging into the SCS and entering the connect command and the Port number or Port name at the command prompt. The SCS acts as a conduit for the connection but does not interfere. When the user is not interacting with a network system, the SCS can log the output of the console port to a file so that data may be reviewed later.

User commands are discussed in *Section 9, User Operations*, beginning on page 55.



## 2.2 System Chassis

Each SCS is housed in a rack-mountable metal chassis. Vents are found on both sides of the chassis. Removable 3-position rack mount brackets are provided. The front panel of the SCS features a two-line, backlit LCD display with five user buttons.



### 2.2.1 SCS80 / SCS160 / SCS320 / SCS480

Each SCS chassis has rear-panel connections for 8, 16, 32 or 48 serial ports, one console port, one network port and power input. The SCS has a built-in universal power supply, a rear-panel power switch and protective fuse.

### 2.2.2 SCS80R / SCS160R / SCS320R / SCS480R

Each SCS-R chassis has rear-panel connections for 8, 16, 32, or 48 serial ports, two console ports and two network ports. The SCS-R has two hot-swappable Universal Power Modules, each with its own power switch and protective fuse (located on the rear of the chassis of the SCS80R, SCS160R and SCS320R; located on the front of the chassis of the SCS480R). Each Power Module is secured with a captive mounting screw.

### 2.2.3 Sentinel 32

Each Sentinel 32 chassis has rear panel connections for 32 serial ports, two console ports, two network ports and two hot-swappable Universal Power Modules, each with its own power switch and protective fuse. The serial ports are arranged in four modules of eight ports each for easy field replacement. The two console and two network ports are in a single module. A module with two network ports, one console port and a V.92 modem port is available as an option. All the modules are hot-swappable.

## 2.3 Connecting to the SCS

All physical connections to the product are made on the rear panel using industry-standard cabling and connectors (purchased separately). All serial connections and network connections use conventional Category 5 cabling with RJ45 jacks. Power is connected using the cord set provided with each SCS system.



**Rear View of SCS320 Chassis**

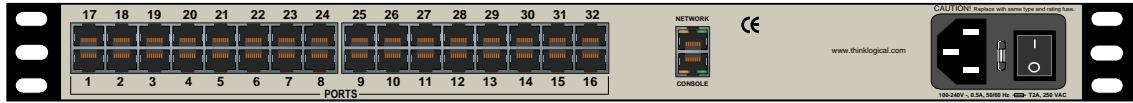

Standard SCS models are similar in size and layout, offering a different number of port connectors. The SCS-R models and Sentinel 32 also have dual NIC, dual console ports and dual power inputs. The rack-mount brackets, extending from both sides of each model, may be removed if desired.

**Rear View of Sentinel 32 Chassis**

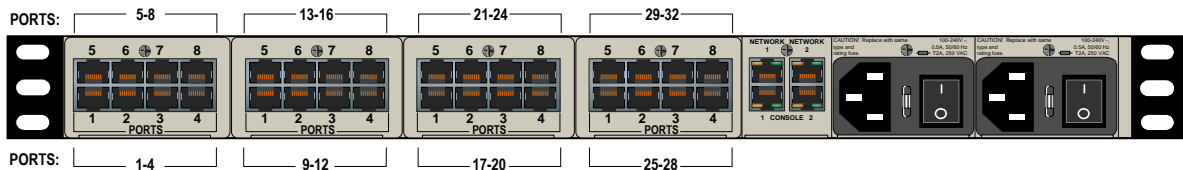

**Note:** Due to the modular design, the Sentinel 32 Serial Port connections on the rear of the chassis are numbered differently from the other SCS models.

**2.3.1 Serial Devices**

All network components attached to both the Console Ports and must be compatible with the EIA-232 standard. CAT5 cabling with RJ45 connectors is used for the Port connections and for the console port. System ports (numbered from **1** to up to **48**) are default-configured as DCE data ports and support a range of baud rates from 300-115.2K. All Port parameters, including DTE or DCE type and other data parameters, are configurable on a per-port basis.

Each port may also be assigned a unique name: *default port names are port1, port2, etc.*

**2.3.1.1 Break Safe**

Thinklogical™ SCS systems are “break-safe”: They will not send a “break” command or other data on the serial ports connected to your servers unless initiated by a user. An unwanted “break” signal could cause problems with your servers.

**2.3.2 IP Network**

The SCS network interface is an auto-sensing 10 BaseT/1 00 BaseTX network connector (equipped with an RJ45 jack with dual LEDs) for use with a conventional TCP/IP network using standard RJ45 CAT5 cables. A default IP address is coded into the system (**10.9.8.7**), but the network settings should be configured by your system administrator for your site’s requirements and equipment. SCS products are preconfigured for ssh (secure shell host) access.



**Note:** The SCS-R and Sentinel 32 models offer two independent network interface ports. Only the first port (NETWORK 1) is enabled by default.

### 2.3.3 AC Power

#### 2.3.3.1 SCS80 / SCS160 / SCS320 / SCS480

A single IEC-type Power Entry Module is located on the rear of the chassis. The power entry module incorporates a replaceable protective fuse (2A) and an On/Off switch. An IEC cord set is provided with each SCS chassis. Connect the cord set to a local AC power source. Turn the power switch on.

#### 2.3.3.2 SCS80R / SCS160R / SCS320R / Sentinel 32

Two removable AC Power Modules, identified as *Left* and *Right* are found on the rear of the chassis. Either AC module can fully support the system and, with both turned on, operate redundantly. The SCS-R and Sentinel 32 systems have an AC power monitoring capability to alert the system administrator in the event of an AC power outage.

Each AC Module has an IEC-type power entry module. The power entry module features a replaceable, protective fuse (2A) and an On/Off switch. Two IEC cord-sets are provided with each SCS-R and Sentinel 32 chassis. Connect both cord sets to a standard AC power source. Turn both power switches ON ( I ).



**Caution!** *BEFORE* removing a power module it is important to *first turn the module off and then remove its power cord. A hazardous voltage condition might otherwise exist.*

#### 2.3.3.3 SCS480R

Two removable AC Power Modules, identified as *Left* and *Right* are found on the front of the chassis. Either AC module can fully support the system and if both are turned on, will operate redundantly. The SCS-R and Sentinel 32 systems have an AC power monitoring capability to alert the system administrator in the event of an AC power outage. A 250VAC 2A fuse is provided on each SCS480R Power Module and can be replaced when the module is removed from the unit.

### 2.3.4 DC Power

The Sentinel and SCS-Rs can be equipped with optional removable -48 VDC Power Modules in place of the AC Power Modules described in paragraph 2.3.3. Either module will fully power the system and will operate redundantly if power is applied to both. The power monitoring circuitry of the SCS-R and Sentinel alert the system administrator in the event of power loss to either module.

## 2.4 User Access Control

Access to a Port is controlled on a per-user basis via a user profile which is stored as a file on the local SCS. This profile is created by the root user using the command 'adduser'. See

Section 8.1.1, *adduser*, on page 54. NIS support is also available.

## 2.4.1 User Sessions

Each SCS supports up to 250 simultaneous user sessions.

## 2.5 Port Buffers

Thinklogical<sup>™</sup> Secure Console Servers provide real-time serial port data buffering. Each port buffer stores up to 256KB of data held in a separate RAM file for each attached device. The data may be viewed when no users are interacting with the attached port. Port buffers are enabled by default.

### 2.5.1 How to Disable Buffering

**Buffering is always ON when no one is connected in Interactive mode.** Buffering may be disabled during an interactive session to ensure privacy after the session ends. (See the `man` page for `stty --buffer` option.)

## 3. Installation

### 3.1 Mounting the SCS

You may choose to rack mount your SCS unit or place it on a desktop. The front panel display should be visible and front panel buttons accessible. All connections are made to the rear of the chassis.

#### 3.1.1 Rack Mount or Desktop

SCS products may be installed either in an EIA-standard 19-inch rack (1U tall) or on a shelf or desktop. For desktop use, rubber feet are provided and the rack mount brackets may be removed. The SCS chassis does not need to be opened or accessed and the sturdy metal case allows units to be stacked as required.

Each rack mount bracket is held on by 4 screws. The brackets may be positioned so that the unit sits forward, flush or recessed in your rack. If the brackets are removed or repositioned, it is not necessary to re-install the extra rack-mount screws.

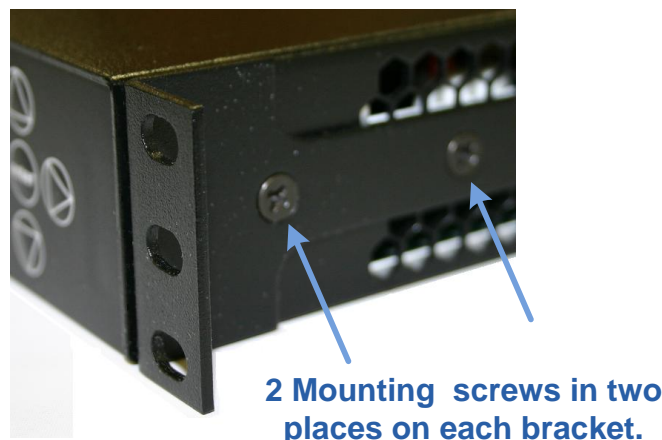

## 3.1.2 Front Panel Display and Buttons

The front-panel LCD display should be visible and accessible during system setup. It typically displays the current network settings and the date/time. The front panel buttons are only used during setup or to review existing SCS settings.



The LCD display can be customized by the root user. See *Section 7.7, Front Panel Display Options*, on page 46 for more information.

## 3.1.3 Convection Cooled

The SCS does not require special cooling or ventilation other than what is normally provided in a standard equipment rack. No fan means that it does not add to the ambient noise in your equipment room. Be sure not to block the air vents on the sides of the unit and leave at least 2” of space on both sides. If mounted in an enclosed rack, it is recommended that the rack have a ventilation fan to provide adequate airflow through the unit(s).



**Note:** Be sure to leave a minimum of 2” of ventilation room on both sides of the SCS chassis, especially if units are being stacked.

## 3.2 Connections

All connections are found on the rear panel of the SCS chassis. Each port is clearly labeled. See the following backpanel diagrams on page 21:

# thinklogical™ Secure Console Servers

Extend • Distribute • Innovate

## SCS320 Secure Console Server

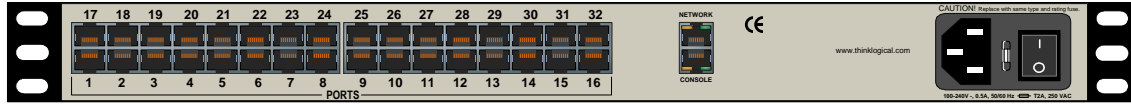

## SCS320R Secure Console Server

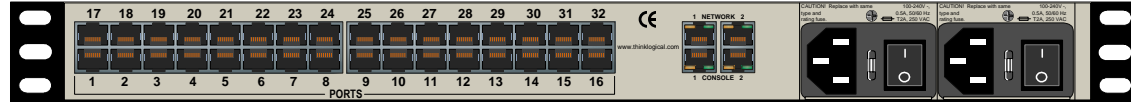

## SCS320M Secure Console Server

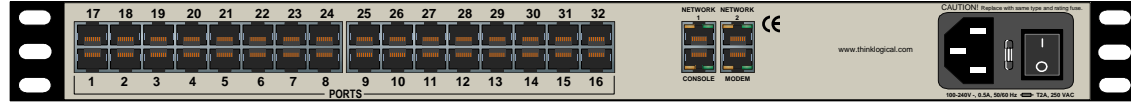

## SCS320RM Secure Console Server

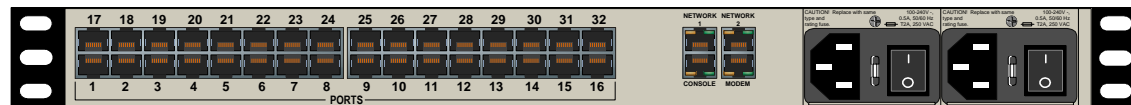

## SCS480 Secure Console Server

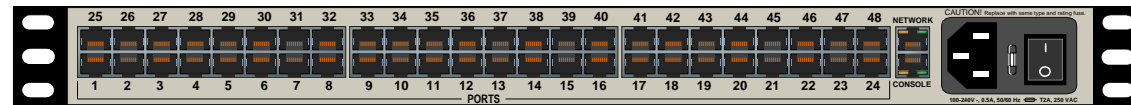

## SCS480R Secure Console Server (ON/OFF Switch located on front panel)

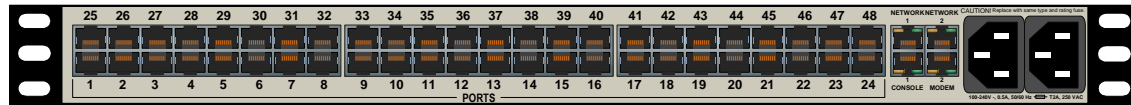

## SCS80 Secure Console Server



## SCS80R Secure Console Server



## SCS160 Secure Console Server

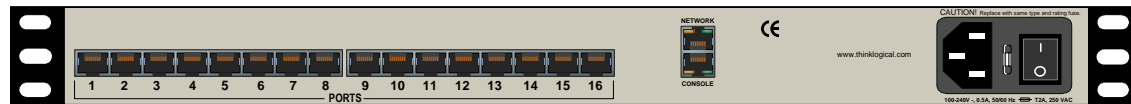

## SCS160R Secure Console Server

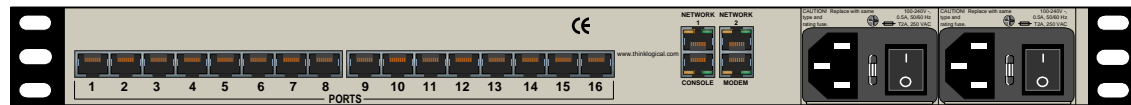

## Sentinel 32

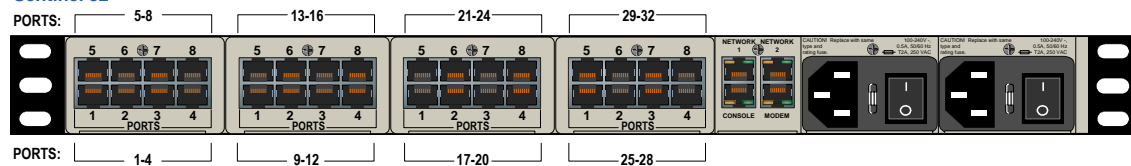

## 3.2.1 Power

SCS products have an internal universal Power Supply. Each SCS unit requires approximately 15W of electrical power. The switching power supply accepts nominal AC input voltage between 100-240 VAC with a frequency range of 50-60 Hz.



**Note:** The optional -48VDC Power Module is described in *Section Appendix D, DC Power*, on page 87.

## 3.2.2 AC Input

A single IEC-type AC power entry module with an integral safety fuse and power switch is located on the rear of the chassis in each AC Power Module. The power input to the chassis uses a removable IEC-type cord set. One is provided with each AC Power Module. Be sure that your AC power source is properly grounded.

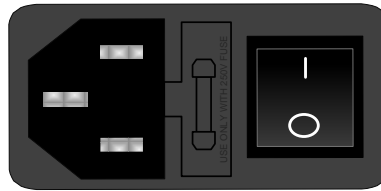

## 3.2.3 Connecting to the Network Port

Use a conventional, fully-pinned Category 5 cable (CAT5) to connect your network to the NETWORK (RJ45) jack on the rear of the chassis.

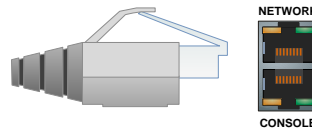

The SCS's network port (auto-selecting 10/100) allows remote access to the attached networking components by the users and the sysadmin functions by the root user. You can change the network parameters from the front panel of the SCS or you may ssh into the default address and make changes using Linux commands.

### 3.2.3.1 SCS-R and Sentinel 32 Dual NIC Interface

The SCS80R / SCS160R / SCS320R / SCS480R / Sentinel 32 have dual network Ports. Initially, only the first NIC is functional (NETWORK 1 = device `eth0`). The second NIC (NETWORK 2 = device `eth1`) must be enabled by the sysadmin.

**To configure the second NIC, the sysadmin will log in and use one of the following commands:**

```
netconfig -d eth1 or netconfig --device=eth1
```

*Refer to Section 6 for other System Commands.*

### 3.2.4 Connect Your Console

The console port is used for local access to the SCS. Connect your terminal or computer to the console port with a terminal emulation package. The SCS's console port has a DCE configuration with adjustable parameters.

The default communication parameters for the console port are:

- **9600 baud**
- **8 data bits**
- **No parity**
- **1 stop bit**
- **Xon/Xoff flow control**

Use a conventional CAT5 cable to connect your terminal or computer to the CONSOLE jack (RJ45) on the rear of the chassis.

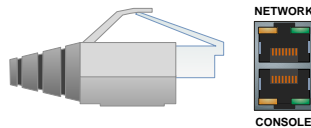

**Login to the SCS:** When connected to the SCS, the `login` as prompt will appear. Log in as `root`. Press **Enter** to continue.

The `password:` prompt comes up next. Enter `root` (the default root password) and press **Enter**.

#### 3.2.4.1 SCS-R and Sentinel 32 Dual Console Interface

The SCS80R / SCS160R / SCS320R / SCS480R / Sentinel 32 have dual Console Ports, with **Console Port 1 pinned as DCE** and **Console Port 2 pinned as DTE**. Console Port 2 is disabled in the default configuration. To use the second console port, the `sysadmin` must enable it.

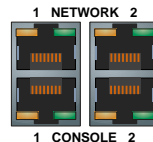

Console Port 2 is activated by editing the file `/etc/inittab`. Refer to Section 6 for other System Commands.

### 3.2.5 Connect to the Ports

Any system (e.g., server, router, switch) with a serial port may be connected to the SCS for consolidated system administration. Server Ports are individually configurable. Consult your server documentation as needed.

The default communication parameters for the server Ports are:

- 9600 baud
- 8 data bits
- No parity
- 1 stop bit
- Xon/Xoff flow control
- DCE Port type

Each Port can be individually configured for baud rates of 300-115K for specified data parameters and as DTE or DCE types.



**Note:** Ports may also be individually disabled if desired.

### 3.2.5.1 Automated Port Configuration Tests

A script named `pm` is available to test the device ports and report the correct DTE/DCE setting for each port. A `man` page exists for `pm`. This can be used to troubleshoot SCS to server connections. Hardware signals from the server are tested but Baud rates are not.

### 3.2.5.2 Port Adapters

You may need to adapt the cable connection for your server device. Thinklogical™ offers serial-to-RJ45 adapters for serial ports, both DB9 and DB25, for many common network-equipment product applications. See Appendix F on page 89 for more information.

### 3.2.5.3 Serial Port Pin-out

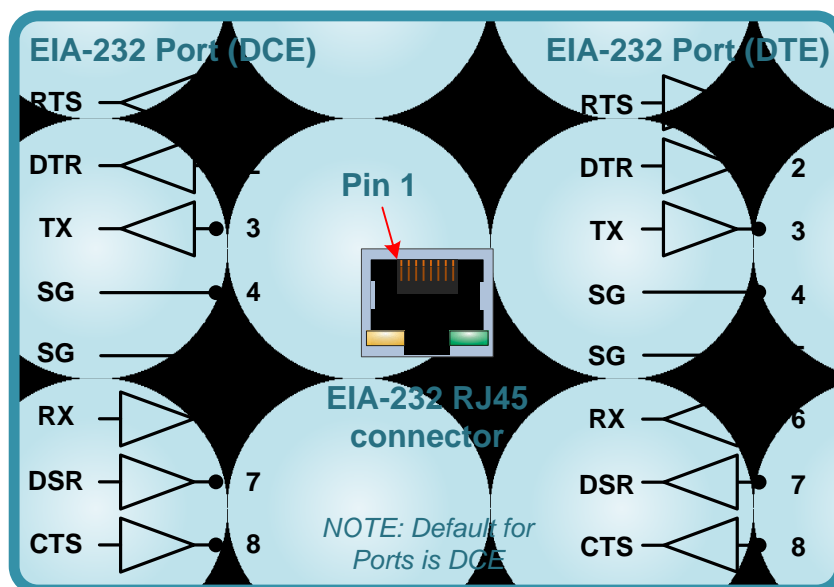

Serial Port pin-out



### 3.3 SCS-R and Sentinel Power Modules

The SCS80R, SCS160R, SCS320R, and Sentinel 32 provide **dual AC Power Modules** which are field-replaceable and connect to the rear panel of the SCS chassis. Each Power Module has a power entry connection with an IEC-type power connector.

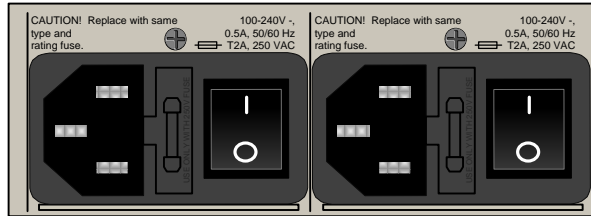

The SCS80R, SCS160R, SCS320R, and Sentinel 32 have a power monitoring display shown on the front panel to indicate if one of the power supplies is not powering the system (either AC power failure, a Module is turned off or the supply has failed).

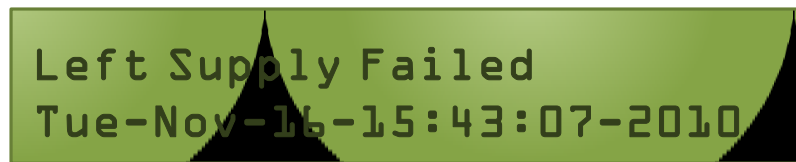

*SCS Front Panel display: Left Power Supply failure*

The SCS480R Power Module is mounted in the front panel of the SCS480R. It has the same capabilities as the SCSR and Sentinel Modules. It is not necessary to remove the AC power cord from the SCS480R when replacing a module.



**Note: The Power Modules in the SCS160/320/480 are not field serviceable. This option applies to the SCS80R, SCS160R, SCS320R, SCS480R and Sentinel 32 only.**

Each Power Module can fully support the SCS80R, SCS160R, SCS320R, SCS480R and Sentinel 32 system. However, the intended design is to have two power sources running your SCS system. When both supplies are active, they will share the system load. If one fails, the remaining supply can then take the full load.

The SCS80R, SCS160R, SCS320R, SCS480R, and Sentinel 32 ship with two AC power cords – one for each module to allow separate AC power source connections. Plug the IEC connection into the SCS AC Power Module and connect the AC cord to a standard AC power source.

#### 3.3.1 Power Module Replacement

The Power Modules of the SCS-R and Sentinel 32 Models may be hot-swapped. Each slide-in Power Module is held in place with a single captive screw and does not need to be removed except for replacement.

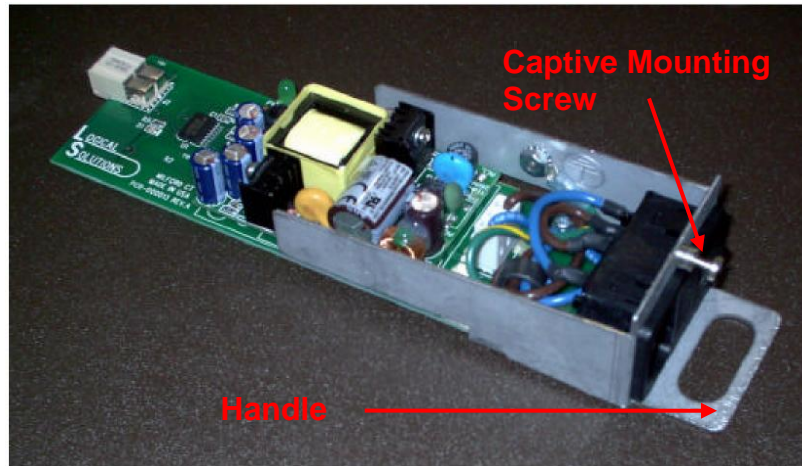

*AC Power Module (removed from SCS Chassis)*

### **SCS80R, SCS160R, SCS320R and Sentinel 32:**

If the front panel display indicates that one of the power supply modules has failed, it may need to be replaced.

A single captive screw (visible from the rear of the SCS80R, SCS160R, SCS320R or Sentinel 32 chassis) holds the Power Module in place and also establishes a protective Earth ground. Be sure to turn off the failed power module and remove its power cord connection. Unscrew the module and remove it from the chassis using the built-in handle on the front of the module.

### **SCS480R:**

If you need to replace one of the SC480R power supply modules, note that the module slides in and out from the front of the chassis.

A single captive screw (visible from the front of the SCS480R chassis) holds the Power Module in place and also establishes a protective Earth ground. Be sure to turn off the failed power module (press switch to O position). It is not necessary to remove the power cord. Unscrew the module and remove it from the chassis using the built-in handle on the front of the module.

Insert the replacement power module and tighten the screw. Reconnect the power cord if necessary and turn on the switch. When power is restored the failure message on the front panel display will clear.

## **3.4 SCS-R and Sentinel -48VDC Power Modules**

The SCS80R, SC160R, SCS320R, and Sentinel 32 provide dual -48VDC Power Modules which are field-replaceable and connect to the rear panel of the SCS chassis. **Each Power Module has a Power IN port with a WAGO MCS power connector.** The SCS80R, SCS160R, SCS320R and Sentinel 32 have a front panel display to indicate if one of the power supplies is not powering the system (either DC power failure, a Module is turned off, or the supply has failed).

The SCS480R Power Module is mounted in the front panel of the SCS480R and has the same capabilities as the SCSR and Sentinel Modules. It is not necessary to remove the DC power cord from the SCS480R when replacing a module.



**Note: The Power Modules in the SCS160/320/480 are NOT FIELD SERVICEABLE. This option only applies to the SCS80R, SCS160R, SCS320R, SCS480R and Sentinel 32.**

Each -48VDC Power Module can fully support the SCS80R, SCS160R, SCS320R, SCS480R and Sentinel 32 systems. However, the intended design is to have two power sources running your SCS system. When both supplies are active, they will share the system load. If one fails, the remaining supply can then take the full load.

The SCS80R, SCS160R, SCS320R, SCS480R and Sentinel 32 ship with two WAGO MCS connectors, one for each module, to allow separate DC power source connections. Plug the WAGO MCS connector into the SCS DC Power Module and connect to a regulated DC power source.

### 3.4.1 Wiring the -48Vdc Connector

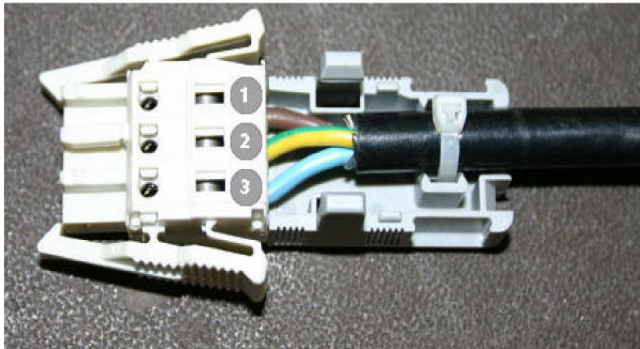

**WAGO MCS DC Power Connector:**

- 1. Brown = -48VDC**
- 2. Green/Yellow = Chassis Ground**
- 3. Blue = Common**

The WAGO DC Power Connector consists of 3 pieces: The *connector plug* and *two halves of the strain-relief back shell*. After installing the wires as depicted above, the three pieces fit together as shown (right) and snap firmly into place.

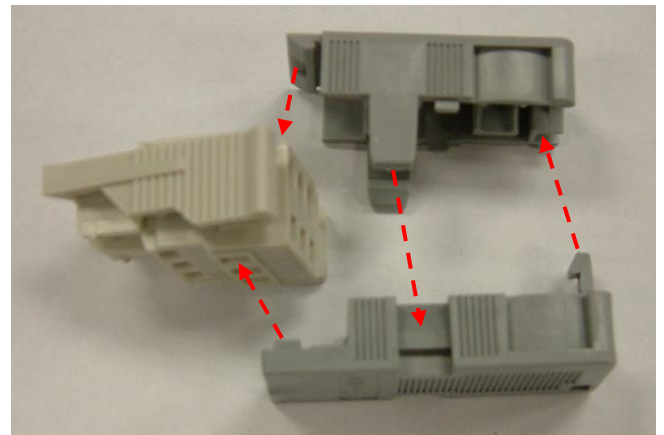

### 3.4.2 -48VDC Power Module Replacement

The Power Modules of the SCS-R and Sentinel 32 Models may be hot-swapped if necessary. Each slide-in Power Module is held in place with a single screw and does not need to be removed except for replacement.



*-48VDC Power Module and WAGO Connector (shown removed from Sentinel 32)*

#### **SCS80R, SCS160R, SCS320R, and Sentinel 32:**

If the front panel display indicates that one of the power supply modules has failed, it may need to be replaced.

A single captive screw (visible from the rear of the SCS80R, SCS160R, SCS320R, or Sentinel 32 chassis holds the Power Module in place and also establishes a protective Earth ground. Be certain to turn off the failed power module (press switch to O position), then remove its power cord connection. Unscrew the module and remove it from the chassis using the built-in handle.

#### **SCS480R:**

If the front panel display indicates that one of the power supply modules has failed, it may need to be replaced. **The power modules insert from the front of the chassis.**

A single captive screw, visible from the front of the SCS480R chassis, holds each Power Module in place and establishes a protective Earth ground. Be certain to turn OFF the failed power module by pressing the switch to the OFF (O) position). Unscrew the failed module and remove it from the chassis using the built-in handle.

You may now Insert the replacement power module and tighten the captive screw. Connect the power cord to the module and turn the switch ON ( I ). When power is restored, the failure message on the front panel display will clear.

## 4. Initial Configuration

*The SCS is Pre-Configured. Just set your IP Address and add Users.*

### 4.1 Default Configuration

The SCS is pre-configured right out of the box, ready to generate ssh keys with an IP address set to a generic default value of **10.9.8.7 / NetMask 255.0.0.0**. It is likely that the sysadmin will want to change to a local IP address.

When you first connect the unit to your network and turn the power on **it will take about two minutes for the SCS to perform the initial ssh key generation**. The front panel display will show the following display after the SCS's power-up is complete and the system is ready:



*SCS Front Panel Display default, normal mode shown*

The top line of the display is the SCS's host and domain name and the second line is a clock display showing day and date (initially set to Eastern Time Zone).

### 4.2 Initial System Security Concerns

*The first login will require several steps to fully secure the SCS.*

When you first connect the SCS and turn it on, it will build the ssh keys during the first two minutes of system startup. During this time, the front panel LCD second line will read `start sshd`, and the console port will read `Starting sshd`.

The root user should also configure the `ntp` and the `ssh config` files. Network 2 and the dual console/modem are disabled. Root is not allowed to login on console 2.

### 4.3 Front Panel Network Setup

**If you changed the network settings via `netconfig`, you can skip this section.**

The Front Panel Display and buttons can be used to set the basic network parameters. There are four **arrow** buttons (Left, Right, Up, Down) and one **enter** button. The front panel can be used to change the *IP Address*, *Subnet Mask*, and *Gateway* settings. By default, the front panel will show the Host name and the Date/Time.

#### 4.3.1 Front Panel Edit Mode

By default the Front Panel Display's Edit mode is enabled. The **View** mode is similar to **Edit** mode except that the front panel cannot be used to change the settings. This is described in *Section 7.7, Front Panel Display Options* on page 46 of this manual.



**Note:** The Front Panel Edit Mode can be disabled if desired. See *Section 7.7, Front Panel Display Options* beginning on page 46.



With Edit mode enabled, use the arrow buttons on the front panel to access the **front panel edit** subroutine and change the default network settings (showing the IP address *Netmask* and *Gateway*) for your SCS system. The front panel controls are self-prompting for the appropriate entries.



SCS Front Panel Display showing the Network Edit Mode



**Note:** Use the *Enter* button to ‘continue’ or to ‘accept’ the current setting. *Your front panel entries must be NO LONGER THAN 30 SECONDS APART or the front panel entry program will time out and discard your entries.*

An asterisk at the far right indicates there is a parameter that has changed from the currently-stored value. These entries will be accepted and held. As you exit this programming mode you are given the opportunity to Save or Cancel your new changes. *If you do not **Save** your settings at this time, your new changes will be discarded.*



**Note:** Front panel changes are not written to the Compact Flash memory until the *sysadmin* uses the command-line ‘save’ command. *Do NOT turn the system power off or these changes will be lost.*

#### 4.3.1.1 Start Front Panel Edit Mode

To start the Edit mode, press the **Up** or **Down** Arrow button on the front panel. The display will change from the default *Domain Name / Date & Time* to the *Edit Mode*. You can scroll through the available Edit functions by pressing the **Up** or **Down** arrows: *Program Network Settings* or *View SCS Settings*



**Note:** If you do not press a button within 30 seconds the display will revert to the normal display and no changes will be made.

Scroll to the **Program Network Settings** display.

#### 4.3.1.2 Program Network

When the *Program Network Settings* mode is selected, you will step through the parameter entry for *Network IP Address*, *Net Mask* and *Gateway*, then *Exit* to the previous menu. The *Up* and *Down* arrows are used to scroll through the available options.

## Network IP Address



*SCS Front Panel Display for Network Programming mode*

Press the **Enter** button to continue.



*SCS Front Panel Display showing the current IP Address*

The current IP Address will be displayed with leading zeroes. **The factory default is 10.9.8.7.** If you do nothing, the display will revert to the previous display after 30 seconds and no changes will be made. To change the IP Address press the **Enter** button.



*SCS Front Panel Display showing Edit IP Address*

A cursor appears under the first character of the existing address. Press the **Left** or **Right** arrow button to move the cursor to the first digit to be changed. To change a digit, use the **Up** or **Down** arrows.



**Note: Ignore any leading zeroes in the display entry. The SCS will adjust for them and will not store the leading zeroes when saving the data.**

As soon as you change a digit an asterisk (\*) will appear at the top-right indicating that a parameter has changed. Input the complete address.



*SCS Front Panel Display (example) with an Asterisk indicating a change*

When the address input is complete, press the **Enter** button to accept the entry. The display will look like the following example:



*SCS Front Panel Display after editing the IP Address*

The new value will be stored when you finish setting all the Network parameters.

## **Net Mask**

Press the **Down Arrow** once to advance to the *Net Mask* parameter.



*SCS Front Panel Display showing the current Net Mask*

Press the **Enter** button to change the *Net Mask* parameter. The current *Net Mask* setting will be displayed with a cursor under the first digit. The factory default is 255.000.000.000. Press the **Left** or **Right** arrow button to move the cursor to the first digit to be changed. To change a digit, use the **Up** or **Down** arrows.



*SCS Front Panel Display editing the Net Mask setting*

As soon as you change a digit an asterisk (\*) will appear at the top-right indicating that a parameter has changed. Change the *Net Mask* as desired.



**Note: Ignore any leading zeroes in the display entry. The SCS will adjust for them and will not store the leading zeroes when saving the data.**

When you have completed entering the parameter values press the **Enter** button to accept the entry. The display will show the following:



*SCS Front Panel Display showing the new Net Mask display.*



The new value will be stored when all the Network parameters are set.

### Gateway

You may now enter your *Gateway* parameter information. Press the **Down** arrow once to continue.



*SCS Front Panel Display showing the current Gateway setting*

Press the **Enter** button to edit the *Gateway* parameter. The current *Gateway* setting will be displayed with a cursor under the first digit.



*SCS Front Panel Display to Edit the Gateway setting*

Press the **Left or Right** arrow button to move the cursor to the first digit to be changed. To change a digit, use the **Up or Down** arrows. As soon as you change a digit an asterisk (\*) will appear at the top-right indicating that a parameter has changed.



**Note: Ignore any leading zeroes in the display entry. The SCS will adjust for them and will not store the leading zeroes when saving the data.**



*SCS Front Panel Display editing the Gateway setting*

When you have the completed entering the parameter values, press the **Enter** button to accept the entry. The display will show the following:



*SCS Front Panel Display showing new Gateway setting*

Your new value will be stored when you are finished setting all the Network parameters.

### Exit to Main Menu

You will now be prompted to *Exit* to the Main Menu. Press **Enter** to continue.



*SCS Front Panel Display exiting the LCD Mode*

You are given the choice to *Save* your changes or to *Cancel* them.



*SCS Front Panel Display to Save or Cancel Changes*

Press **Enter** to save your network changes or press the **Up** arrow to discard them. When you have completed the changes, the system must restart the *Network Daemon*. (The *Network Daemon* periodically connects to the network to check for updates and notifications.) This process will be displayed on the front panel display. The display will revert to a normal display when the network is restored.



*SCS Front Panel Display - Saving and Restarting*

When the system has restarted the network services, the following is displayed:



*Returned to normal SCS Front Panel Display*

To **permanently save** your new Network settings in the system, you must use the SAVE command to write the values to the Compact Flash memory.



**NOTE: If the system loses power before using the command-line SAVE command, the front-panel-entered network parameter changes will be lost.**

## 4.4 Initial Connection via Network

You can access the SCS using ssh (secure shell host) commands with your existing network. If you add a route to your workstation, you can connect to the SCS via its default address. For security reasons, a telnet server is not active on the SCS.

### 4.4.1 Network Connection Requirements

- Have your SCS system connected to the network before you turn it on.
- Know your computer's IP address.

### 4.4.2 Route via Linux Workstation

*If using a Windows workstation, you may go to section 4.4.3.*

**If you are accessing the network from your Linux / UNIX workstation, enter:**

```
route add -net 10.9.8.7 netmask 255.255.255.255 gw <your  
workstation's IP address>.
```

**To access the SCS system using ssh, from your command line, enter:**

```
ssh root@10.9.8.7
```

Default root password is `root`.

You should now be at the SCS's root command prompt.

**It is recommended that one of the first changes you make is to your SCS's network address. See Section 7.2, Change Network Address, on page 43.**

### 4.4.3 Route via Windows Workstation

*If using a Linux workstation, you may skip this section.*

If using Windows 9x/2000/XP you can connect to the SCS using your networked Windows PC and an ssh-capable terminal emulation package.



**Note:** If you don't have an ssh-capable terminal emulation package, an available option is PuTTY, a freely-distributed package you can download at the following address:

<http://www.chiark.greenend.org.uk/~sgtatham/putty/>.

**(PuTTY is a client program for the ssh, Telnet and Rlogin network protocols. These protocols are all used to run a remote session on a computer over a network.)**

**If you use a Windows PC to login to the SCS:**

1. Determine your PC's IP network address. One method: open a DOS prompt window and type `ipconfig`, then press **Enter**. Your PC's IP address is listed, among other things.
2. Add the route between the PC and the SCS. From a DOS prompt, enter:  

```
route add 10.9.8.7 mask 255.255.255.255 <workstation's IP address>  
then press Enter
```

3. “Ping” the SCS to assure that your network connection is now functioning. (The ping command is a way to verify a network connection.) Type `ping 10.9.8.7` at the DOS prompt, then press **Enter**. Check for a completed connection.
4. Connect to the SCS with your terminal package using ssh. Launch your terminal package and connect to the default IP address of the SCS of 10.9.8.7 using ssh.

If using PuTTY (shown below), set the Session window IP address to 10.9.8.7, select the ssh radio button and press **Open**.

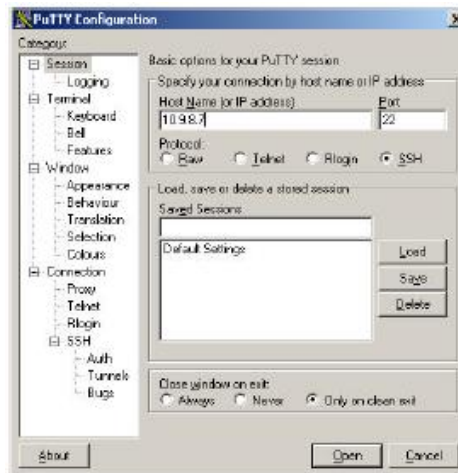

*PuTTY configuration Screen*

The first time you connect using ssh you will get a warning about the ssh authentication keys. Accept the newly-generated keys by choosing **yes**.

5. Login to the SCS. When connected to the SCS, the “login as:” prompt will appear. Log in as **root**. Press **Enter** to continue.

The “password:” prompt comes up next. Enter **root** (the default root password) and press **Enter**.

Upon pressing **Enter** you will be at the SCS’s root command prompt. For this case, connect using PuTTY to ssh into 10.9.8.7:

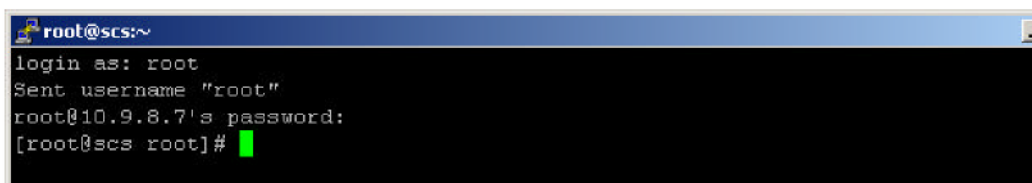

*Terminal screen showing a typical root login to SCS*

When successfully logged in, you will see the command prompt ending with # followed by the cursor.

**It is recommended that one of the first changes you make is to your SCS’s network**

**address.** See *Section 7.2, Change Network Address*, on page 43.

## 4.5 Initial Connection via Console port

See *Section 3.2.4, Connect your Console*, on page 23.

## 4.6 How to Access the LSI SCS Web Setup Interface

Be sure to add the proper route statement (`route add 10.9.8.7...`) to your workstation (see paragraph 4.4.3, Step 2, on page 35).

1. From your browser, type: <https://10.9.8.7:8098/>
2. A predefined SSL (**Secure Sockets Layer**) certificate will be used. Your browser may warn you that the certificate does not match the host. You may continue using this certificate, but you should create a new certificate after setting up the SCS.
3. Refer to the file `/usr/local/doc/ssl.cert.README` for more information about creating certificates.
4. Press **Start**.
5. Enter `root` as the user name and `root` as the password.
6. The main configuration menu is displayed. Make your changes. `Help` is available for each page.
7. When all your changes are made, select **Control Panel** from the Main Menu and then select **Shutdown/Reboot**. Reboot the SCS and all your changes will take effect.

This interface is for setup only. It cannot be used to access the device ports. To disable the web interface, see the instructions located in `/lsi/README`.

## 5. System Overview

### 5.1 SCS Systems are Linux-based

Thinklogical<sup>™</sup> Secure Console Server products use the GNU/Linux operating system.

#### 5.1.1 Linux General Public License

The GNU/Linux source code used in this product has been distributed under a General Public License (GPL) from the Free Software Foundation. You may read about the GNU GPL by reviewing the text version of the GPL, which can be found at <http://www.gnu.org/licenses/gpl.txt>.

You will find additional GNU license information online at <http://www.gnu.org/licenses/licenses.html#GPL>.

Please contact **Thinklogical<sup>™</sup> Product Support** (1-203-647-8700 or toll-free at 1-800-291-3211) if you need a copy of this source code.

### 5.1.2 SCS System Architecture

SCS software design uses both RAM (volatile) and Compact Flash (non-volatile) memory. All system changes are maintained in RAM until they are written to the Compact Flash memory. A read-only memory system is used since Compact Flash memory devices have a limited number of read-write cycles.

After making administrative changes to the system, the root user must run the `SAVE` command to write the changes to the non-volatile memory. If the data changes are not saved, the parameter changes will be lost in the event of a power failure or power-down.

## 5.2 Initial System Administrator (sysadmin) Access

When the SCS is first powered up, you may need to configure it to operate with your network. Use `ssh` to access the SCS or the local console (*Section 3.2.4, Connect Your Console*, on page 23).

The SCS uses familiar Linux commands to administer the system. This manual lists those Linux commands that are important for the SCS sysadmin to know (See table on page 40).

### 5.2.1 Enter Commands

The system administrator enters Linux commands using the command-line interface. Unless otherwise shown, commands are all lower-case and may have modifiers. SCS commands are discussed in *Section 6, Commands*, beginning on page 40.

### 5.2.2 Log Out

To log out from a session, use the command `logout`. If logging out from a network session, the Console Server will disconnect the `ssh` session.

## 5.3 Default Services

The following Services are enabled by default:

- `network`
- `ssh`
- `syslog`
- `cron`

You may add other features and services, depending on your application. When you first log into the system, you will get the following reminder message for configuration:

To customize the SCS configuration for your location, we suggest you do the following:

```
*CHANGE THE ROOT PASSWORD!!!  
*reconfigure the network (netconfig)  
*set the time zone, if not in the Eastern U.S. (timeconfig)  
*add users (adduser)  
*edit the ntp.conf file and then enable the ntpd service
```

**For extra security:**

```
*edit the sshd_config file to not allow root logins  
*when all settings are changed, reboot the system to save the changes
```

*SCS login advice (displayed on-screen when you first log in)*

### 5.3.1 Configure the Services

When you first install the SCS system, you should configure the default services for your needs. This addresses *network*, *date/time*, *authorizations* and *system hostname*. The feature commands described below are discussed in *Section 7, System Administration*, beginning on page 43.

*In order to configure the basic services, you must:*

1. **Run some or all of the following:**  
(netconfig, changehostname, timeconfig, authconfig).
2. **Run** save
3. **Run** service network restart **to restart the network.**

*To configure the existing features, use the following commands:*

- **For the Network parameters, use** netconfig
- **To change the host and domain name, use** changehostname
- **For the Date/Time, use** timeconfig
- **To change the time zone for the authentication protocols, use** authconfig

## 6. Commands

*A summary of special SCS Commands*

### 6.1 System Commands

SCS products use Linux commands and `man` pages are available for all system commands. The root user can access the following commands to configure the special features of the SCS:

COMMAND	PURPOSE	CHPT.
<code>adduser</code>	Add a User (creates a new user account)	8
<code>deluser</code>	Delete a User account	8
<code>editbrk</code>	Edit the 'break' sequence	8
<code>editesc</code>	Edit Interactive mode 'escape' sequence	8
<code>edituser</code>	Edit user settings for existing User accounts	8
<code>save</code>	Commit programming changes to non-volatile memory	6
<code>stty</code>	Configure Port parameters (see Linux commands)	6
<code>versions</code>	Show version information	6

*The commands are discussed in the chapter numbers noted on the right.*

#### 6.1.1 save

SCS systems will maintain your settings in RAM memory as long as system power is applied and the system remains in a normal operating condition. To permanently store your parameters, the root user must use the `save` command to write the data changes to the non-volatile Compact Flash memory card. This will ensure that your data is permanently saved.

The `save` command does not store buffered port data, which is held in RAM.



**Note: The root user should run `save` any time that the system configuration has been changed. This includes user password changes and any command-line system administration changes**

The `save` command is automatically run when you execute the `reboot` or the `poweroff` commands. It will copy files located in `/etc`, `/home`, `/usr` and `/root` to the Compact Flash and restore them when the system is restarted.

#### 6.1.2 reboot

The `reboot` command may be run at any time. The `save` command is run as a part of the reboot process which occurs immediately after your data has been saved. A `reboot` takes a



minute or so to complete. After the reboot has run the underlying commands, the system will reset and then begin the start-up process as it does at power on.



**Note: No ‘break’ commands will be sent on the serial Ports during a SCS system reboot. Your servers will not be affected.**

Thinklogical™ SCS systems are “break-safe”, meaning that they will not send a ‘break’ command (unless user initiated) or other data on the serial ports connected to your servers. An unwanted ‘break’ could cause problems with your server.

### **6.1.3 poweroff**

*If you want to turn the SCS off, you must first run the `poweroff` command.*



**Note: No ‘break’ commands will be sent on the serial Ports during a SCS system poweroff cycle. Your servers will not be adversely affected.**

`poweroff` may be run at any time. The `save` command is run as part of the `poweroff` process. Once you have entered the `poweroff` command, the operating system will shut down and the SCS will cease operating. The front panel display will show `OK to Power Off`. You may now turn the power switch off.

The only way to recover from a `poweroff` command is to turn the system power off and then turn the power back on.

### **6.1.4 Other Linux Commands**

*The following Linux commands, among others, will be used with the SCS systems.*

#### **logout**

Use `logout` to quit your session with the system.

#### **man**

Use `man <command name>` to search for a help file (online manual pages) or descriptive information for that Linux / UNIX command.

**Three general man pages are available for the Logical Solutions™, Inc. commands and files. They are:**

1. `lsi.1` for user commands
2. `lsi.8` for system commands
3. `lsi.5` for Logical Solutions™, Inc. file descriptions

#### **passwd**

***The root user should change the default root password as soon as possible to prevent unauthorized access.*** To change the default root password, type `passwd` (all lower case) at the root login prompt.

## **scp**

Use `scp` for **secure copy** using `ssh` (secure shell host) between two hosts. The process is encrypted and inherently secure. Refer to the `man` pages for `scp` for a description and any command options.

## **sftp**

Use `sftp` for a **secure file transfer** transaction between two servers using `ssh`. This process is similar to `ftp` except that it is encrypted for security. *Refer to the `man` pages for `sftp` for a description and any command options.*

## **ssh**

The SCS systems use `ssh` to establish secure connections over your network. The configuration file for the `ssh` server is `/etc/ssh/sshd_config`. This controls `ssh` connections **to** the SCS.

Use `ssh` to establish a secure connection between two hosts or to transfer files or data between the systems. The Secure Console Server is a client device and will be connected to an `ssh` elsewhere. The security keys for `ssh` may need to be generated using `ssh-keygen`, depending on your application of `ssh`. *Refer to the `man` pages for `ssh` for a description and any command options.*

## **ssh-keygen**

Use `ssh-keygen` to create keys for users so passwords do not have to be used for `ssh` login. You can generate the security keys for your client system (in this case, the SCS is the client) to interact with an `ssh` host elsewhere. After the keys have been generated, the user can establish a secure shell connection using `ssh` over a network. *Refer to the `man` pages for `ssh` for a description and any command options.*

## **stty**

Use `stty` to change the configuration for each Port. The system provides a default configuration for the system Ports (`tttyB1` through `tttyB48`), and for the console port (`tttyS0`).



**Note: Port changes made using `stty` are temporary (not written to memory). In order to keep any changes, you must edit the configuration file in `/etc/rc.d/rc.serial` and then run `save`.**

The Ports are identified as `/dev/ttyB1` through `/dev/ttyB48` for ports 1 through 48, respectively, and `/dev/ttyS0` for the console port.



**Note: For example, to administer Port 7 you would edit the file `rc.serial` and use `stty -F /dev/ttyB7`.**

*Refer to the `man` pages for `stty` for a description and any command options.*

## **versions**

Use `versions` to see a listing of the release versions of the LSI files in the SCS.

## 6.2 Change Logging Level

The `sysadmin` may wish to change the logging level of `syslog`.

1. Login as `root`
2. Edit the file `/etc/syslog.conf` (`vi/etc/syslog.conf`)
3. Restart the system logger by entering: `service syslog restart`
4. Run `save`.

## 7. System Administration

*This section outlines the administration functions and commands that are accessed using the network or console ports.*

### 7.1 Security

Thinklogical<sup>™</sup> Secure Console Servers use `ssh` to provide encryption for a secure network connection. There is only one level of system administration access in the SCS and that is at the root level.



**Caution: Anyone with the root password has the ability to access all SCS features and functions. Your root password should be carefully guarded.**

In general, users cannot interact with the system-level features. Only users with permission to interact with a port can access the buffers or clear the buffered data.

### 7.2 Change Network Address

You may use the Front Panel setup (see *Section 4.3, Front Panel Network Setup*, beginning on page 29) to configure the SCS's IP address. This will temporarily change the IP address to allow you to connect to the SCS. Front panel changes are temporary because there is no way to write the new parameters to non-volatile memory using the front panel keys.

You must run `netconfig` once you have accessed the SCS to change the network parameter options and then save the parameters to non-volatile memory.

#### 7.2.1 Run `netconfig`

After you establish a connection to the SCS (either through your console port or via `ssh` using the default address of 10.9.8.7), you may need to change the IP address setting of the SCS to the desired address on your network, using `netconfig`. The `netconfig` command is a self-prompting program to set up your system's network information. It supports DHCP/BOOTP setup or static addressing. Use the **space bar** to select/deselect a value (e.g., DHCP). Use the **arrow keys** to move up and down between the entry fields.



**Note: Use of a static IP address is recommended with the SCS.**

You will need the following information before running `netconfig`:

- Using DHCP/BOOTP (yes/no)? **If No, you will need the following:**
- IP Address
- Net Mask
- Default Gateway
- Primary Nameserver

You can add the secondary and tertiary nameservers (if required) by editing the `resolv.conf` file at any time. After entering the requested information, you are returned to the root prompt. See *Section 7.2.2: More Than One Nameserver* on page 45.

### 7.2.1.1 Save your `netconfig` changes

After running `netconfig` to set up your system, you must run the `save` command to keep your changes. Then restart the network using the following steps:

1. Make all changes
2. Run `save`
3. Run `service network restart` to restart the network
4. Make a new `ssh` connection.



**Note:** If you are making several changes to the system configuration, you may complete all the changes and then run `save`.

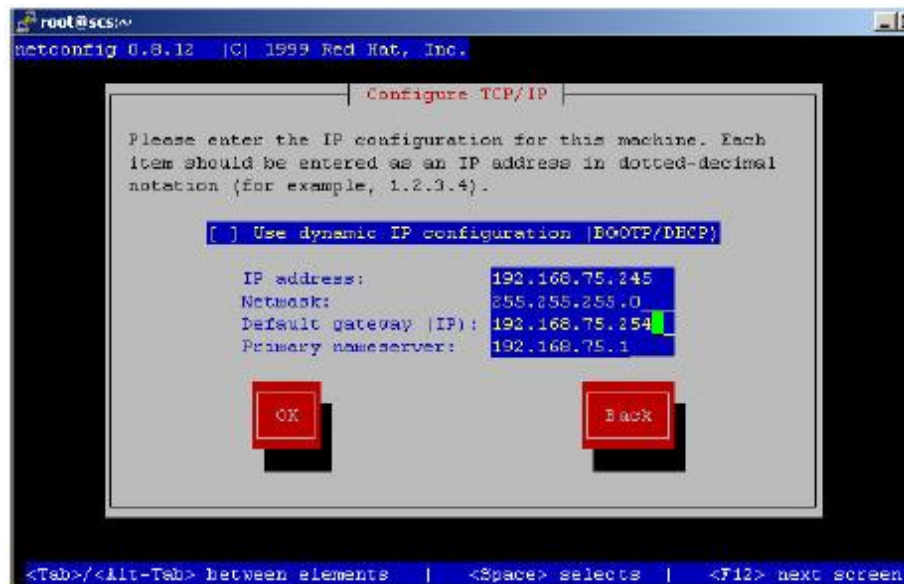

Example of `netconfig` fill-in fields

When you have filled in the fields, **arrow down** to the **OK** button and press **Enter** to accept your entries.

## 7.2.2 More Than One Nameserver

The `netconfig` command allows the user to set up one nameserver's IP address. It is possible to have multiple nameservers, which must be done outside of the `netconfig` command. The nameserver data is in the file `/etc/resolv.conf`. If you want to have more than one nameserver, you must edit the file. *For more information, refer to the man page for `resolv.conf`.*

In this file, you will find the IP address you entered with `netconfig`. You can add the address of additional nameservers. (a maximum of 3 nameservers is allowed) to this file. The format of a line is: `nameserver <IP address>`.

## 7.3 Change Hostname

The SCS includes a command `changehostname` which allows the root user to change the long hostname of the SCS unit.

1. Log in as `root`.
2. Type `changehostname`. The current hostname is displayed and you are prompted to choose `y/n` to proceed.
3. If you select `y` (yes) to change, you are prompted to enter the new hostname.



**Note:** If you make a mistake in your entry, do not attempt to edit it. Reject the incorrect entry and re-enter the value properly.

4. Enter your new hostname value. Press `y` to accept the new value.
5. Remember to run `save` when done to keep your new values.
6. After changing the hostname and/or clock settings, reboot to make the changes permanent. These two settings (clock and hostname) are only saved during an orderly shutdown. Loss of power before reboot will revert to the old values.

## 7.4 Time Configuration

Use the command `timeconfig` to set up the date/time and time coordinates. This is a self-prompting utility. To keep your values, run `save` when completed. After changing clock settings, reboot the SCS to make changes permanent.



**Note:** If changing the Time Zone (during `timeconfig` changes) restart the LCD display service so the front panel display can update. Use the command `service lcd restart` after completing the `timeconfig` options.

## 7.5 Change NIC Speed

You can change the NIC interface configuration to *auto-sensing* or *fixed*, to *full* or *half duplex*, and to *10Mb* or *100Mb*. The following file information is found in the file `/etc/modules.conf` with some additional instructions on to how to set the NIC speed.

This file already has the various commands in place, but they are commented out (rendered inactive by the preceding #). Edit the `/etc/modules.conf` as required. Remove the leading # from **one** of the `#options` lines below to make it active, then reload the NIC driver.

```
alias eth0 eepro100
alias char-major-72 exser
alias char-major-4 off
options -k exser
##
## options to control NIC speed and mode
## remove the leading '#' from ONE of the options lines below
##
### 100Mbit half-duplex
#options eepro100 options=0x20, 0x30
### 10Mbit half-duplex
#options eepro100 options=0x40, 0x50
```

The SCS system power should be cycled (using **poweroff**, not **reboot**). The power-off is done to inform the switch connected to the NIC that it is now *off*.



**Note:** In the SCS-R and Sentinel 32 Models, these changes affect **BOTH** network ports. It is not possible to change only one of the network ports.

## 7.6 Configure Authentications

Use `authconfig` to set up the authentication protocols. You may only need to run this if you need remote authentication such as NIS, LDAP, Kerberos, etc.

The first checkbox, `cache information`, will start the `nscd` daemon if selected. Refer to the `man` page `nscd` for configuration options. This is not required for normal operation and need not be selected.

Other aspects of the authentication options in `authconfig` are self-prompting for parameters for NIS, LDAP and/or Hesiod.

Remember to run `save` to keep your new values.

## 7.7 Front Panel Display Options

The front panel display is a two line, 24 character, backlit LCD. It displays system messages during various system events (e.g., network restart, poweroff), but most of the time is idle and shows the default display.

The default display shows the **Hostname on the top line** and the **Date/Time on the lower line**, but this can be customized to show other information in either line or both. This can be helpful in labeling each SCS in a rack with multiple units. Also, the default display can be turned off and **the editing of IP address information using the front panel buttons can be disabled to prevent unauthorized changes**.



*Default Front Panel Display,*

The front panel will display system messages during events such as reboot or save, but will return to the default display following these events.

### 7.7.1 Display Mode Parameters

The various LCD Display modes are controlled by entries maintained in the file:

`/etc/sysconfig/lsci`

- LCD\_LINE\_1=
- LCD\_LINE\_2=
- LCD\_DISPLAY\_SETTING=
- LCD\_LINE\_1= and LCD\_LINE\_2= (allows text entry of up to 24 characters to be displayed)
- LCD\_DISPLAY\_SETTING= (can be set to EDIT [default], VIEW, or OFF)

#### 7.7.1.1 Edit

The Edit mode (LCD\_DISPLAY=EDIT) allows the front panel display to show the current display information and allows anyone to use the front panel display to change the network parameters (IP Address, Net Mask, and Gateway).

#### 7.7.1.2 View

The View mode (LCD\_DISPLAY=VIEW) allows the front panel display to show the current information, but disables editing using the front panel buttons. This prohibits unauthorized changes to your network settings from the front panel.

#### 7.7.1.3 LINE\_1=

LINE\_1= allows the user to customize data on the upper line of the display. The root user may enter a left-justified text line of up to 24 characters to replace the SCS Host-name.



*LINE\_1 Changed in SCS Front Panel Display,*

#### 7.7.1.4 LINE\_2=

LINE\_2= allows the customer to customize data on the lower line of the display. The root user may enter a left-justified text line of up to 24 characters to replace the clock/date display.





LINE\_2 Changed in SCS Front Panel Display

### 7.7.1.5 Display OFF

LCD\_DISPLAY=OFF disables the front panel LCD display when no events are taking place. The backlighting will remain on, but the display is blank.

## 7.8 Network Time Service

*Network Time Service* is supported. To use the network time service, the user must edit the files `/etc/ntp.conf` and `/etc/ntp/step-tickers` and start the `ntpd` service as described in the following paragraphs. (More information is available at [www.ntp.org](http://www.ntp.org))

### 7.8.1 Configure NTP

The file `/etc/ntp.conf` has many options. To define the time server to be used, the hostname (or IP address) of the time server is needed. Using your editor, add the line: `server <my time server name or IP address>` to the end of the file.

**Example:** For the hostname `ts1.mydomain` your entry is `server ts1.mydomain` (The user will type the *actual hostname* [or IP address] of the time server in place of `ts1.mydomain`.)

The user should also add the server names to the file `/etc/ntp/step-tickers`. This file requires the *name* of the time server (the word 'server' as used in the file `/etc/ntp.conf` is not needed)

### 7.8.2 Start the NTP Service

To start the NTP service manually: `service ntpd start`

To cause NTP to start automatically during startup: `chkconfig ntpd on`

## 7.9 NIS and User Port Permissions

The SCS can use NIS to control user access to the Ports in addition to controlling user access to the SCS itself. Since this is an extension to the normal NIS capabilities, some of the NIS files must be installed on your NIS server. The user must create/ modify the NIS database to include records containing user port permissions.



**Note:** Source documents, including this information, are stored on the SCS system. NIS information is located in `/usr/local/doc/nis`.

### 7.9.1 User Port Control

The SCS can use NIS to control which user can access a port on the SCS. To use this feature, a database must be created on the NIS server. **The following files are needed to set up the port access database:**

<code>lsi_port_access</code>	Port Access Permission Definition file
<code>lsi_port_user</code>	Port Access User Definition file
<code>lsi_port_awk</code>	Port Access AWK file (required for the Make file)
<code>Makefilenis.portAccess</code>	Make file used to build the LSI database

### 7.9.2 NIS Port Access

The file `lsi_port_access` contains the port permissions for **connect**, **monitor** and **clear** and is referenced by a *group*. Users may define as many *groups* as needed. The following example, where **perm** = *permission*, illustrates how the group file is constructed:

```
group name:console server name:connect perm:monitor perm:clear perm
```

*where:* **group name** is the name of the user's group  
**console server name** is the SCS's hostname  
**connect perm** is the port that a group can connect with  
**monitor perm** are the ports that a group can monitor  
**clear perm** are the ports that a group is allowed to clear

For example: `pbxgrp:tvscs320:1,2-6,13:5-9:1-7`  
`itgrp:tvscs160:8-16:7:1,3,5,7-11`

*The above example shows two groups, pbxgrp and itgrp, that are allowed to access ports on a Secure Console Server.*

The first group, `pbxgrp`, can access an SCS with the hostname of `tvscs320`. The group can connect to ports 1, 2, 3, 4, 5, 6 and 13. It can monitor ports 5, 6, 7, 8 and 9. This group is allowed to clear ports 1, 2, 3, 4, 5, 6 and 7.

The second group, `itgrp`, can access the SCS with a hostname of `tvscs160`. This group can connect to ports 8, 9, 10, 11, 12, 13, 14, 15 and 16. It can monitor port 7, and can clear ports 1, 3, 5, 7, 8, 9, 10 and 11.

#### LSI Port Access Permission file

Port Access Permission for the user defined group names\* are defined below.

*Permissions can be any or all of the following forms:*

- decimal value
- decimal range using a dash (-) as the range indicator
- a comma (,) used to separate digits and/or ranges
- a colon (:) used as the field separator, as in:

*group name:console server name:connect perm:monitor perm:clear perm*

```
* user_group1:scs160_milford:1-16:1-3,5,8,16:0
* user_group2:scs320_boston:1-6:12,15:3-7
```

### 7.9.3 User Names and Groups

The *LSI Port User Definition* file (`/nis/lsi_port_users`) is used to assign a user to a given Port Access group. This file information is found in `/usr/local/doc/nis`.

The following example illustrates how it is set up:

```
User name:group name
where:  user name is a valid SCS user
       group name is a valid users' group
```

For example:

```
tomv:pbxgrp
billf:itgrp
```

The above example shows two users, **tomv** and **billf**. User **tomv** is in the group `pbxgrp` and **billf** is in the group `itgrp`. When used with the `lsi_port_access` file, it illustrates how **tomv** can log into `tvscs320` and be able to connect, monitor and clear the ports that were set up in the previous example. The same goes for **billf**.

#### LSI Port Access User definition file

Port Access user and respective port access group names are defined below.

- Users must be valid system usernames.
- Group names are those defined in the `lsi_port_access` file.

```
lsiuser1:user_group1
lsiuser2:user_group1
lsiuser3:user_group2
lsiuser4:user_group2
```

#### Group Permissions

A user might not have access to a particular port, depending on group permissions. Only members of the `scsusers` group (group ID of 701) may access SCS ports. Only members of the `monitor` group (group ID of 702) may access SCS monitor ports.

### 7.9.4 NIS Database file

The `lsi_port_awk` file is used to create the lsi database file (`lsiportdbase`) on the NIS server. It contains the `awk` code that the Make file needs.

### 7.9.5 NIS Make file

The file `Makefile.nis.portAccess` is used to create the lsi port database.

To build the database, the above files (listed in *Section 7.9, NIS and User Port Permissions*, on page 48) need to be loaded onto the NIS server. The system has been tested on a Linux CPU running RedHat 8.0. The files were placed in the `/var/yp` directory. After executing the Make

file, the `lsi` database file was placed in the NIS host directory.

### 7.9.6 NIS Configuration File

The NIS configuration file (located at `/etc/nsswitch.conf`) must be edited by the user to support your NIS server. To do this:

1. Open the file `/etc/nsswitch.conf` using your editor.
2. Edit (add or modify) a line to your config file that supports local files for local users and, if not assigned locally, refers to the NIS database. The line should read:  
`port_access:filesnis`
3. Save your updated `nsswitch.conf` file.

## 7.10 NFS

NFS information can be obtained from the `man` pages, which is an overview of setup information for an NFS application as it pertains to the SCS. Refer to the following:

`man` pages:`nfs`, `mount`, `fstab`.

### 7.10.1 Remote NFS Directory

To mount a remote directory onto the SCS you must start the `portmap` and `netfs` services. To manually start `portmap` and `netfs` services, enter the commands:

```
service portmap start
service netfs start
```

To automatically start `portmap` and `netfs` services at *Power On*, enter the commands:

```
chkconfig portmap on
chkconfig netfs on
```

Determine which local directory name you will use to refer to the remote directory. The standard name is `/mnt`. If you need more than one remote directory mounted, create the additional directories under the `/mnt` directory. (e.g., `/mnt/dir1`, `/mnt/dir2`, `/mnt/dir3...`)

To test the mounting, enter the following:

```
mount -t nfs <remote server name>:<remote directory name> <local
directory name>
```

**Example:** `mount -t nfs nyc:/usr/local/cvs/mnt/dir2`



**Note:** To have this mount occur at startup, you must edit the file `/etc/fstab`. See the `man` pages noted above for details.

For example:

```
nyc:/usr/local/cvs/mnt/dir2nfs, intr
```

## 7.11 SNMP

*Simple Network Management Protocol* (SNMP) governs network management and the monitoring of network devices and their functions. Network management stations monitor and control the network components. SNMP is supported in the SCS as “read only”. Refer to the `man` pages for more details.

### 7.11.1 Start SNMP

Start SNMP with the command

```
service snmpd start chkconfig snmpd on
```

## 7.12 syslog

Using default settings, the SCS will log all warnings and higher events. The SCS keeps a system log file called `/var/log/messages`. The level of logging is controlled by the file `/etc/syslog.conf`.

SCS products can log the following:

**Notice level events:**

- Port settings changed
- Begin and end Interactive mode
- Port buffer cleared

**Info level events:**

- User settings modified
- Port buffer accessed

The default file entry is `*.notice`, with lower level settings in `*.info`. (A lower level setting generates more messages.)

## 7.13 Timeouts

The SCS system supports *timeout* on the network port. Refer to the `man` page for `timeout` options. Use the commands `timeoutd` and `timeouts`.

## 7.14 Changing Serial Port Settings

Use `stty` to change things like the port name, baud rate or hard/soft flow control. Note that these changes are temporary and will be lost on the next reboot. To make the changes permanent, edit the file `/etc/rc.d/rc.serial`. This file contains a list of `stty` commands (one for each port).

### 7.14.1 Disable buffering while in Interactive

To prevent unauthorized access, do not store data in the Port buffer while in *Interactive mode*. Under normal conditions, all data from the serial device is stored in the buffer and can be viewed at a later time. To disable buffering (only while the Interactive mode is in progress), use the command:

```
stty -F/dev/ttyBn -buffer
```

## 8. Administering Users

The following commands are used to change settings for users. You can define as many users as you wish, up to the memory capacity of the system. The limiting factor for users is not the number of users but the number of simultaneous sessions invoked by any number of users (250 sessions maximum).

### 8.1 User Setup

Each user account must have a unique name and its own password. Each User account has the following parameters:

PARAMETER	CONSTRAINTS
<i>Name</i>	A unique user name made up of contiguous characters that cannot be renamed. This name will be displayed at the command prompt when a user has logged in.
<i>Password</i>	Linux password for this user account.
<i>Port range or Port group (used below)</i>	Default is set to access all ports in the SCS chassis (1-16, 1-32 or 1-48). Ports can be assigned individually (1), in a contiguous range (2-7), in random ports (3,6,9,15) or any combination of the above valid port numbers for that chassis (1, 4-7, 12, 15-16).
<i>ESCAPE_SEQ</i>	Escape sequence. Default is "Esc-A". Displayed in ASCII (x1bA)
<i>BREAK_SEQ</i>	Break sequence. Default is "Esc-B". Displayed in ASCII (x1bB)
<i>ALLOW_CLEAR</i>	Range or group of Ports for which this User account can Clear the Port Buffers.
<i>ALLOW_CONNECT</i>	Range or group of Ports to which this User account can connect
<i>ALLOW_MONITOR</i>	Range or group of Ports which the User can monitor

There are three permissions in the user config files:

- **ALLOW\_CONNECT:** The user can enter *Interactive mode*. The file name is `/dev/ttyBnnn` . To browse a buffer a user must have connect permissions on that port.
- **ALLOW\_MONITOR:** The user can view a specified port. The file name is `/dev/monitor_portnnn` and must be opened in Read-Only mode.
- **ALLOW\_CLEAR:** A user can clear a specified buffer. The file name is `/proc/port_buffers/nnn`

#### 8.1.1 adduser

SCS users are identified with a user name and the `adduser` command is used to create a new user account. The user's name, password and port access configurations are set, along with the `escape` and `break` command keystrokes. After a user has been added, this user can log into the system from a network or console port connection.

### 8.1.2 edituser

The `edituser` command is used to change the parameters for an existing user. **The user name cannot be edited using `edituser`.** In order to modify a user's name you must generate a new user account and enter the appropriate assignments. You should then delete the original user account (paragraph 8.1.3).

### 8.1.3 deluser

The `del user` command deletes an existing user account.



**Note:** The following command modifiers (options) apply to the `add user` and `edituser` commands.

### 8.1.4 Other Editing Commands

The following commands may be entered to change the following parameters. The root user may change the preset values for these parameters and a user may use this command to change the parameters for the Port they are connected to.

#### 8.1.4.1 editbrk <name>

Use `editbrk <name>` to edit the `break` sequence for a user. The `break` sequence is presented in its ASCII form. (User key stroke default is **ESC – B.**)

#### 8.1.4.2 editesc <name>

Use `editesc <name>` to edit the `escape` sequence for a user. The `escape` sequence is presented in its ASCII form. (User key stroke default is **ESC – A.**)

## 9. User Operations

*Commands that End Users need to connect to their Servers through the SCS*

### 9.1 User Accounts

The SCS has two types of user accounts: `user` and `root` and supports multiple user accounts, each having a unique combination of read, write and review privileges for each of the Ports. Each user account is password protected and a defined user may or may not have permission to interact with the attached servers.

#### 9.1.1 SCS users

SCS users are the individuals that will connect to any or all of the attached networking devices for service, support or access needs. There can be many users defined and each user, when connecting to the system, establishes a session with a selected device by entering the `connect` command. There can be up to 250 simultaneous user sessions.

#### 9.1.2 root user

The **root user** differs from other SCS users in that the root user will act as the System



Administrator (sysadmin) for the full SCS system and has full access to the each of the SCS Ports. *There is only one root user for each SCS system.*

The root user defines the access rights of all users in the SCS system. The root user's access is secured with the root password (default password is **root**). The root password should be changed regularly and carefully guarded to prevent unauthorized access.

## 9.2 Port Identities

Each Port is numbered and has a default name (`port1`, `port2`, etc.) but may be given any name by the sysadmin. Each user interacts with the servers connected to ports by entering a command associated with either the port number or port name.

## 9.3 What Users Can Do

**Remember:** Use `connect <Port number or name>` to access a specific server or network device.

### 9.3.1 Access via Network

To access a connected server via the SCS network port, the user should use an ssh client to ssh to the IP address of the SCS.

#### 9.3.1.1 Secure Shell Host (ssh) to a Port

You can ssh directly to a port by using the following command:

```
ssh user@scs -t -t connect <port number or name>
```

### 9.3.2 Access via console port

The console port is normally used by the System Administrator during service events. However, it can be used by any user that has access to the terminal and has a password to log into the system and access system Ports.

### 9.3.3 Interactive Mode

For a user to interact directly with an attached server, the user must enter the *Interactive mode*. Use `connect <port name or number>` to connect to a port (only applies to ports for which the user is allowed *Connect* access).

The user's terminal is then connected to the. The SCS displays the last page of the port buffer along with a system information message indicating which Port is selected as the user enters Interactive mode. If a user attempts to connect to a port that is in use, they will receive the message `Device or Resource busy`.

The *Interactive Mode Escape Sequence* is a series of two to ten characters that allows the user to exit Interactive Mode and return to the System Prompt. The default for the Interactive mode escape sequence is `<ESC>A` (**escape** key, then uppercase **A**). The user may change the sequence by using the command `editesc`.

#### 9.3.3.1 Break Sequence

The user is not connected directly to the server, but rather is connected through the SCS, and

therefore cannot use the **break** key. While a user is connected to a port in the Interactive mode the user can, however, send a break command to that port. The default sequence is <ESC>B

### editbrk

When not in the Interactive mode, a user can enter `editbrk` to edit or view their preset break sequence. The break sequence is presented in its ASCII form (x1bB). The user key stroke default is <ESC>B. Press **Enter** to keep the existing setting.



**Caution: Because the sysadmin is responsible for configuration changes, it is generally recommended that only the sysadmin should be allowed to change the break sequence.**

### 9.3.3.2 Escape Sequence

A user-defined sequence of keys is used to leave the Interactive mode. The default sequence is <ESC>A



**Note: Do NOT use combinations of the <CTRL> key and other keys for the escape sequence as these combinations are usually reserved for sending and receiving special characters through a terminal.**

**Edit Escape Sequence:** It is recommended that only the sysadmin edit the `escape` command sequence. When logged in, enter `editesc` to edit or view the preset `escape` sequence. The `escape` sequence is presented in its ASCII form (x1bA). The user key stroke default is <ESC>A. Press **Enter** to keep the existing setting.



**Caution: Because the sysadmin is responsible for configuration changes, it is generally recommended that the sysadmin should be the one to change the escape sequence.**

## 9.4 Monitor Mode

*Monitor Mode* allows a user to view the traffic on a port, but not to interact with it. Once in *Monitor Mode*, pressing any key will close the connection. Multiple users may monitor the same port at one time, unlike Interactive mode, which is limited to one user. A port may be monitored while an interactive session is in progress. The `monitor` command uses the same syntax as the `connect` command.

## 9.5 Browse the Buffers

Any of the Linux text browsing commands (`less`, `more`, `ftp`, `tftp`, `scp`, etc.) may be used to view the Port buffers. These buffers are named:

```
/lsi/ports/buf_<name> or /proc/port_buffers/<number>
```

## 9.6 Clear the Port Buffers

Use the following commands to erase the data in a Port buffer:

```
stty --clear -F/proc/port_buffers/<n>
```

or

```
stty --clear -F/lsi/ports/buf_<name>
```

# 10. Regulatory and Safety Compliance

## 10.1 Safety Requirements

### 10.1.1 Symbols Found on Our Products

*Markings and labels on our products follow industry-standard conventions. Regulatory markings found on our products comply with all domestic and many international requirements.*

## 10.2 Regulatory Compliance

Thinklogical Secure Console Server™ products are designed and made in the USA. They have been tested by a nationally recognized testing laboratory and found to be compliant with the following standards (both domestic USA and many international locations).

### 10.2.1 North America

**These products comply with the following standards:**

#### Safety

- ANSI/UL60950-1: 1<sup>st</sup> Edition (2003)
- CAN/CSA C22.2 No. 60950-1-03

#### Electromagnetic Interference

- FCC CFR47, Part 15, Class A
- Industry Canada ICES-003 Issue 2, Revision 1

### 10.2.2 European Union

#### 10.2.2.1. Declaration of Conformity

##### Product name

- Model: SCS80 Secure Console Server, SCS801 Secure Console Server
- Model: SCS160 Secure Console Server, SCS1601 Secure Console Server
- Model: SCS320 Secure Console Server, SCS3201 Secure Console Server
- Model: SCS480 Secure Console Server, SCS4801 Secure Console Server
- Model: SCS80R Secure Console Server, SCS801 R Secure Console Server
- Model: SCS160R Secure Console Server, SCS1601 R Secure Console Server
- Model: SCS320R Secure Console Server, SCS3201 R Secure Console Server
- Model: SCS480R Secure Console Server, SCS4801 R Secure Console Server
- Model: Sentinel 32 Secure Console Server, Sovereign 32 Secure Console Server

These products comply with the requirements of Low Voltage Directive 72/23/EEC and EMC Directive

89/336/EEC.

### 10.2.2.2 Standards to Which Our Products Comply

#### Safety

- IEC60950:1992+A1, A2, A3, A4, A11

#### Electromagnetic Emissions

- EN55022: 1994 (IEC/CSPR22:1993)
- EN61000-3-2/A14: 2000
- EN61000-3-3: 1994

#### Electromagnetic Immunity

- EN55024:1998 Information Technology Equipment-Immunity Characteristics
- EN61000-4-2:1995 Electro-Static Discharge Test
- EN61000-4-3:1996 Radiated Immunity Field Test
- EN61000-4-4:1995 Electrical Fast Transient Test
- EN61000-4-5:1995 Power Supply Surge Test
- EN61000-4-6:1996 Conducted Immunity Test
- EN61000-4-8:1993 Magnetic Field Test
- EN61000-4-11:1994 Voltage Dips & Interrupts Test

### 10.2.2.3 Supplemental Information

The following statements may be appropriate for certain geographical regions but might not apply to your location.



**Note:** This equipment has been tested and found to comply with the limits for a Class A digital device, pursuant to part 15 of the FCC Rules. These limits are designed to provide reasonable protection against harmful interference when the equipment is operated in a commercial environment. This equipment uses, generates and can radiate radio frequency energy and, if not installed and used in accordance with the instruction manual, may cause harmful interference to radio communications, in which case the user may be required to correct the interference.



**Note:** This Class A digital apparatus complies with Canadian ICES-003 and has been verified as compliant within the Class A limits of the FCC Radio Frequency Device Rules (FCC Title 47, Part 15, Subpart B Class A), measured to CISPR 22: 1993 limits and methods of measurement of Radio Disturbance Characteristics of Information Technology Equipment.

This Class A digital apparatus meets all requirements of the Canadian Interference-Causing Equipment Regulations.

Cet appareil numérique de la classe A respecte toutes les exigences du Règlement sur le matériel brouilleur du Canada.



**Note:** Users may notice degraded audio performance in the presence of electromagnetic fields.

## 10.3 Product Serial Number

Secure Console Server products have a unique serial number, imprinted on a small silver label that is placed on the bottom of the chassis. The serial number includes a date-code. The format for the date-code is two digits for the month; two digits for the day and two digits for the year and two or three digits for a unique unit number. This serial number is also found on the original shipping carton.

## 10.4 Lithium Battery

The SCS products have a replaceable, long-life Lithium battery (CR2032, 3 volt) to support the system BIOS which will likely never need field replacement. However, if it ever does need to be replaced, the following caution statement applies:



**Caution:** There is a risk that the battery could explode if it is replaced by an incorrect type. Be sure to use only a CR2032, 3 volt lithium battery. Properly dispose of unused batteries.

## 10.5 SCS-R Models and Sentinel 32 Power Modules

The SCS80R, SCS160R, SCS320R, SCS480R and Sentinel 32 systems have hot-swappable Power Modules that can be replaced in the field without interrupting service. Each Power Module is held in place with a single captive screw.



**Caution:** When replacing a Power Module in the field, first turn the power switch off, then remove the Power Cord BEFORE loosening the captive screw and pulling the module out. When replacing the module, fully insert the module and tighten its screw before replacing the power cord.

# 11. How to Contact Us

## 11.1 Customer Support

**Thank you for choosing Thinklogical™ products for your application.**

We appreciate your business and are dedicated to helping you successfully use our products, so you can be confident that Thinklogical™ will always be here to help you. **To contact us, please use the following telephone numbers and internet-based methods:**

### 11.1.1 Website

Visit our website at [www.thinklogical.com](http://www.thinklogical.com) for more product information, current updates and the full line of Thinklogical<sup>™</sup> products.

Our internet website offers product information on all current systems, including technical specification sheets and Quick Start Guides (for viewing online or for download), product diagrams showing physical connections and other useful information. **We are continually updating our website, so be sure to update your browser when visiting the Thinklogical<sup>™</sup> website to see our most up-to-date information.**



**Note:** Most online documents are stored as Adobe Acrobat .pdf files. If you do not have the Adobe Acrobat reader needed to view .pdf files, visit [www.adobe.com](http://www.adobe.com) for a download.

### 11.1.2 Email

Thinklogical<sup>™</sup> is staffed Monday through Friday from 8:30am to 5:30pm, Eastern Time Zone. We will try to respond to your email inquiries promptly. Please use the following email addresses for your various needs:

[Info@thinklogical.com](mailto:Info@thinklogical.com) – Information about Thinklogical<sup>™</sup> and our products.

[sales@thinklogical.com](mailto:sales@thinklogical.com) – Sales Department: orders or questions.

[support@thinklogical.com](mailto:support@thinklogical.com) – Product support, technical issues or questions, product repairs and request for *Return Merchandise Authorization*.

### 11.1.3 Telephone

**Telephone Sales:** Please contact our expert sales staff in Milford, CT at **1-203-647-8700** or, if in the continental US, use our toll-free number **1-800-291-3211**. We are here Monday through Friday from 8:30am to 5:30pm, Eastern Time Zone. Be sure to ask for your sales representative's direct dial phone number when you call.

**Telephone Product Support:** Please contact our expert Product Support staff in Milford, Connecticut at **1-203-647-8700**. The support lines are manned Monday through Friday, 8:30am to 5:30pm, Eastern Time Zone.

**International Sales:** Please contact our expert Sales Staff in Milford, Connecticut, USA at **1-203-647-8700**. We are here Monday through Friday, 8:30am to 5:30pm, Eastern Time Zone (same as New York City). If leaving a voice message, please provide a preferred time to call back so we may reach you at your convenience.

Our switchboard attendant will direct your call during regular business hours. We have an automated attendant answering our main telephone switchboard after regular business hours and on holidays. You may leave a voice message for any of our representatives at any time. Each of our sales and service representatives has a direct number to accommodate your calls.

### 11.1.4 Fax

Our company facsimile number is **1-203-783-9949**. Please indicate the nature of the fax on your cover sheet and provide return contact information, including your phone number.

## 11.2 Product Support

Thinklogical's<sup>™</sup> support personnel are available Monday through Friday from 8:30am to 5:30pm, Eastern Time Zone. If you require assistance at some time outside of our normal business hours, please contact us beforehand and we will do our best to make arrangements to assist you.

### 11.2.1. Limited Warranty Information

Thinklogical<sup>™</sup>, LLC ("Thinklogical") warrants this product against defects in materials and workmanship for a period of one (1) year from the date of delivery (ordinary wear and tear excluded). This limited warranty does not cover defects resulting from (i) use of the product other than as described in the applicable documentation for the product; (ii) modifications to or repairs of the product that are made by any party other than Thinklogical<sup>™</sup> or a party acting on Thinklogical's<sup>™</sup> behalf, or (iii) combination of the product with third party products that is not consented to by Thinklogical<sup>™</sup>. Occurrences of events described in (i) – (iii) shall void the foregoing warranty. This warranty gives you specific legal rights, and you may also have other rights which vary from state to state.

**Except for the express warranty set forth above, to the fullest extent permitted under applicable law, Thinklogical<sup>™</sup>, LLC and its suppliers disclaim any and all other warranties, express and implied, including without limitation the implied warranties of merchantability, fitness for a particular purpose, title and non-infringement.**

If the defective product is returned to the authorized dealer within one (1) year of the delivery date, repair or replacement of the product will be made. Repairs may be made with refurbished parts. If repair or replacement is not possible, Thinklogical<sup>™</sup> may keep the defective product and refund the amount that you paid for the defective product. These are Thinklogical's<sup>™</sup> sole obligations, and your exclusive remedies, for a breach of the limited warranty set forth above.

To return a defective product, contact the Thinklogical<sup>™</sup> authorized dealer from whom you purchased the product. Do not return a product directly to Thinklogical<sup>™</sup> without prior authorization from your dealer.

If you have received prior authorization from your dealer and are returning a product directly to Thinklogical<sup>™</sup>:

1. Contact your sales representative, or call Customer Support at (800)291–3211 or + (203)647–8700.
2. Describe the product defect and Customer Support will issue a *Return Merchandise Authorization Number (RMA#)*.
3. If possible, pack the product in all of its original packing and be sure to include the RMA number with the address, so it is clearly visible on the outside of the box.



4. Return the product to:

**Thinklogical, LLC**

**Attn: RMA#** (Insert the RMA# issued to you by Thinklogical™, here.)

**100 Washington Street**

**Milford, CT 06460 USA**

### **11.2.2 Our Address**

If you have any issues with our products, have product questions or need technical assistance, please call us at **1-203-647-8700** and let us help.

If shipping something with an RMA number, use the address above. If you'd like to write us, our street address is:

**Thinklogical**, a subsidiary of *Logical Solutions™, Inc.*

**100 Washington Street**

**Milford, CT 06460 USA**

## Appendix A: File System

### A.1 Read-Only vs. Read-Write

In some instances you may need to interact directly with the SCS's file system, in which case you must mount it for **read-write (R/W) access** before changes can be made to the system's Compact Flash.

**To mount R/W:** `mount -o remount,rw/`



**Caution: Regular SCS use does not require changes to the Read-Write operation. The sysadmin may only need to use this to interact with the SCS's Linux file system directly. Do not leave the system in Read-Write mode. Leaving the system in read-write mode could shorten the life span of the SCS.**

The SCS's file system is normally mounted in a **read-only mode** and is run from RAM to prolong the life (read-write cycles) of the system's Compact Flash memory card. **Leaving the system in read-write mode could shorten the life span of the SCS.**

**To mount R/O:** `mount -o remount,ro/`

#### A.1.1 Read-Only Mode for Normal Use



**Note: It is VERY IMPORTANT to remount as Read-Only when you are done with any changes.**

During system startup, the *tar* file is expanded into RAM. The root file system is then mounted as Read-Only. It must be remounted as Read-Write in order to make changes (e.g. `mount -o remount,rw/`)

#### A.1.2 LSI Directories

The following LSI directories are those most often used with SCS products:

```
/etc  
/home  
/var  
/root  
/lsi
```

The `save` command tars these directories and stores the tar file in `/misc`.

## Appendix B: FAQ

*A few frequently-asked questions*

### B.1 How To...

This section is a collection of tips and hints for various setup items. The root user can change any of the following features using the given command steps:

#### B.1.1 Change Port Parameters

Serial Port settings are modified via the `stty` command (see `man` page `stty`). The serial port settings are modified in the `rc.serial` file to be permanently changed. Note the following:

- Changing port names is persistent over a reboot
- Changing port communication settings (baud rate, parity etc.) is temporary. The file `/etc/rc.serial` must be edited in order to save the settings.

To change the Port Parameters, edit the file: `/etc/rc.d/rc.serial`

For example, to change the baud rate for Port 5 to 19,200 baud, enter:

```
Stty -F/dev/ttyB5 19200 {other options}
```

#### B.1.2 Change the Name of a Port

You can change the name of a Port if you know the original name. For example, to change the Port `<current name>` to `payroll`, enter:

```
Stty --name=payroll -F/lsi/ports/<current name>
```

#### B.1.3 View a Buffer

Use `less` or `cat` to view a port's buffer. There are at least two methods:

```
/lsi/ports/buf_<portname> or /proc/port_buffers/<portnumber>
```

## Appendix C: Sentinel 32 Modem Commands

The following modem commands information has been extracted, with the permission of the modem's manufacturer, from the Multi-Tech Systems, Inc., Developer's Guide.



### Introduction

The AT commands are used to control the operation of your modem. They are called *AT* commands because the characters AT must precede each command to get the *AT*tention of the modem.

AT commands can be issued only when the modem is in command mode or online command mode.

The modem is in *command mode* whenever it is not connected to another modem.

The modem is in *data mode* whenever it is connected to another modem and ready to exchange data. *Online command mode* is a temporary state in which you can issue commands to the modem while connected to another modem.

To put the modem into online command mode from data mode, you must issue an *escape sequence* (+++) followed immediately by the AT characters and the command, e.g., +++ATH to hang up the modem. To return to data mode from online command mode, you must issue the command ATO.

To send AT commands to the modem you must use a communications program, such as the HyperTerminal applet in Windows 98/ 95 and NT 4.0, or some other available terminal program. You can issue commands to the modem either directly, by typing them in the terminal window of the communications program, or indirectly, by configuring the operating system or communications program to send the commands automatically. Fortunately, communications programs make daily operation of modems effortless by hiding the commands from the user. Most users, therefore, need to use AT commands only when reconfiguring the modem, e.g., to turn auto answer on or off.

The format for entering an AT command is **ATXn**, where X is the command and n is the specific value for the command, sometimes called the command *parameter*. The value is always a number. If the value is zero, you can omit it from the command; thus, **AT&W** is equivalent to **AT&W0**. Most commands have a *default value*, which is the value that is set at the factory. The default values are shown in the "AT Command Summary" (See below).

You must press ENTER (it could be some other key depending on the terminal program) to send the command to the modem. Any time the modem receives a command, it sends a response known as a *result code*. The most common result codes are *OK*, *ERROR*, and the *CONNECT* messages that the modem sends to the computer when it is connecting to another modem. See a table of valid result codes at the end of this chapter.

You can issue several commands in one line, in what is called a command *string*. The command string begins with AT and ends when you press ENTER. Spaces to separate the commands are optional; the command interpreter ignores them. The most familiar command string is the *initialization string*, which is used to configure the modem when it is turned on or reset, or when your communications software calls another modem.

### AT Command Summary

Organization of AT Commands on the following pages: 1st, by the initial command character (&, +, %) 2nd, alphabetized by the second command character (Except for listing of AT)

Command	Description
AT	Attention Code
A	Answer
A/	Repeat Last Command
Bn	Communication Standard Setting
Ds	Dial
DS=y	Dial Stored Telephone Number
En	Echo Command Mode Characters
Fn	Echo Online Data Characters
Hn	Hook Control

# **thinklogical<sup>™</sup>** Secure Console Servers

Extend • Distribute • Innovate

<b>Command</b>	<b>Description</b>
<b>In</b>	Information Request
<b>Mn</b>	Monitor Speaker Mode
<b>Nn</b>	Modulation Handshake
<b>On</b>	Return Online to Data Mode
<b>P</b>	Pulse Dialing
<b>Qn</b>	Result Codes Enable/Disable
<b>Sr=n</b>	Set Register Value
<b>Sr?</b>	Read Register Value
<b>T</b>	Tone Dialing
<b>Vn</b>	Result Code Format
<b>Wn</b>	Result Code Options
<b>Xn</b>	Result Code Selection
<b>Zn</b>	Modem Reset
<b>&amp;Cn</b>	Data Carrier Detect (DCD) Control
<b>&amp;Dn</b>	Data Terminal Ready (DTR) Control
<b>&amp;En</b>	XON/XOFF Pass-Through
<b>&amp;Fn</b>	Load Factory Settings
<b>&amp;Gn</b>	V.22bis Guard Tone Control
<b>&amp;Kn</b>	Flow Control Selection
<b>&amp;Ln</b>	Leased Line Operation
<b>&amp;Pn</b>	Pulse Dial Make-to-Break Ratio Selection
<b>&amp;Qn</b>	Asynchronous Communications Mode
<b>&amp;Sn</b>	Data Set Ready (DSR) Control
<b>&amp;Tn</b>	Loopback Test (V.54 Test) Commands
<b>&amp;V</b>	Display Current Settings
<b>&amp;Wn</b>	Store Current Configuration
<b>&amp;Zy=x</b>	Store Dialing Command
<b>\An</b>	Select Maximum MNP Block Size
<b>\Bn</b>	Transmit Break
<b>\Kn</b>	Break Control
<b>\Nn</b>	Error Correction Mode Selection
<b>\Qn</b>	Flow Control Selection
<b>\Tn</b>	Inactivity Timer
<b>\Vn</b>	Protocol Result Code
<b>-Cn</b>	Data Calling Tone
<b>%A</b>	Adaptive Answer Result Code Enable
<b>%B</b>	View Numbers in Blacklist
<b>%Cn</b>	Data Compression Control
<b>%DCn</b>	AT Command Control
<b>%En</b>	Fallback and Fall Forward Control
<b>%Hn</b>	Direct Connect Enable
<b>%Rn</b>	Cisco Configuration
<b>%Sn</b>	Command Speed Response
<b>\$EBn</b>	Asynchronous Word Length
<b>\$Dn</b>	DTR Dialing
<b>\$MBn</b>	Online BPS Speed
<b>\$SBn</b>	Serial Port Baud Rate
<b>#CBAn</b>	Callback Attempts

Command	Description
#CBD <i>n</i>	Callback Delay
#CBF?	Callback Failed Attempts Display
#CBFR	Callback Failed Attempts Reset
#CBI <i>n</i>	Local Callback Inactivity Timer
#CBN <i>y=n</i>	Store Callback Password
#CBP <i>n</i>	Callback Parity
#CBR <i>y</i>	Callback Security Reset
#CBS <i>n</i>	Callback Enable/Disable
#P <i>n</i>	Set 11-bit Parity
#S <i>x</i>	Enter Setup Password
#S= <i>x</i>	Store Setup Password
+VDR= <i>x, y</i>	Distinctive Ring Report
+++AT<CR>	Escape Sequence
%%ATMTSMODEM<CR>	Remote Configuration Escape Sequence
V.92 Commands	

## AT Commands

Command: **AT** **Attention Code**

Values: n/a

Description: The attention code precedes all command lines except **A**, **A**: and escape sequences.

Command: **ENTER Key**

Values: n/a

Description: Press the ENTER (RETURN) key to execute most commands.

Command: **A** **Answer**

Values: n/a

Description: Answer call before final ring.

Command: **A/** **Repeat Last Command**

Values: n/a

Description: Repeat the last command string. Do not precede this command with **AT**. Do not press ENTER to execute.

Command: **B*n*** **Communication Standard Setting**

Values: *n* = 0–3, 15, 16

Default: 0 and 15

Description:

- B0 Select ITU-T V.22 mode when modem is at 1200 bps.
- B1 Select Bell 212A when modem is at 1200 bps.
- B2 Deselect V.23 reverse channel (same as **B3**).
- B3 Deselect V.23 reverse channel (same as **B2**).
- B15 Select V.21 when the modem is at 300 bps.
- B16 Select Bell 103J when the modem is at 300 bps.

Command: **D*s*** **Dial**

Values: *s* = dial string (phone number and dial modifiers)

Default: none

Description: Dial telephone number *s*, where *s* may up to 40 characters long and include the 0–9, \*, #, , B, C, and D characters, and the **L**, **P**, **T**, **V**, **W**, **S**, comma (,), semicolon (;), !, @, ^ and \$ dial string modifiers. **Dial string modifiers:**

- L** Redial last number. (Must be placed immediately after **ATD**.)
- P** Pulse-dial following numbers in command.
- T** Tone-dial following numbers in command (default).

- ✓ Switch to speakerphone mode and dial the following number. Use **ATH** command to hang up. **W** Wait for a new dial tone before continuing to dial. (**X2**, **X4**, **X5**, **X6**, or **X7** must be selected.)
- ,
- ;
- ! Hook flash. Causes the modem to go on-hook for one-half second, then off-hook again.
- @ Wait for quiet answer. Causes modem to wait for a ringback, then 5 seconds of silence, before processing next part of command. If silence is not detected, the modem returns a NO ANSWER code.
- ^ Disable data calling tone transmission.
- \$ Detect AT&T call card "bong" tone. The character should follow the phone number and precede the user's call card number: **ATDT1028806127853500\$123456789**

<p>Command:           <b>DS=y</b></p> <p>Values:             </p> <p>Default:           </p> <p>Description:       </p>	<p><b>Dial Stored Telephone Number</b></p> <p><i>n</i> = 0–2 (0–1 for SMI-Parallel {internal})</p> <p>none</p> <p>Dial a number previously stored in directory number <i>y</i> by the <b>&amp;Zy=x</b> command. Example: <b>ATDS=2</b></p>
<p>Command:           <b>En</b></p> <p>Values:             </p> <p>Default:           </p> <p>Description:       </p>	<p><b>Echo Command Mode Characters</b></p> <p><i>n</i> = 0 or 1</p> <p>1</p> <p>E0     Do not echo keyboard input to the terminal.</p> <p>E1     Do echo keyboard input to the terminal.</p>
<p>Command:           <b>Fn</b></p> <p>Values:             </p> <p>Default:           </p>	<p><b>Echo Online Data Characters</b></p> <p><i>n</i> = 1</p> <p>1</p> <p>F0     Enable online data character echo. (Not supported.)</p> <p>F1     Disable online data character echo (included for backward compatibility with some software).</p>
<p>Command:           <b>Hn</b></p> <p>Values:             </p> <p>Default:           </p> <p>Description:       </p>	<p><b>Hook Control</b></p> <p><i>n</i> = 0 or 1</p> <p>0</p> <p>H0     Go on-hook (hang up).</p> <p>H1     Go off-hook (make the phone line busy).</p>
<p>Command:           <b>In</b></p> <p>Values:             </p> <p>Default:           </p> <p>Description:       </p>	<p><b>Information Request</b></p> <p><i>n</i> = 0–5, 9, 11</p> <p>None</p> <p>I0     Display default speed and controller firmware version.</p> <p>I1     Calculate and display ROM checksum (e.g., <i>12AB</i>).</p> <p>I2     Check ROM and verify the checksum, displaying <i>OK</i> or <i>ERROR</i>.</p> <p>I3     Display default speed and controller firmware version.</p> <p>I4     Display firmware version for data pump (e.g., <i>94</i>).</p> <p>I5     Display the board ID: software version, hardware version, and country ID</p> <p>I9     Display the country code (e.g., <i>NA Ver. 1</i>).</p> <p>I11    Display diagnostic information for the last modem connection, such as DSP and firmware version, link type, line speed, serial speed, type of error correction/data compression, number of past retrains, etc.</p>
<p>Command:           <b>Mn</b></p> <p>Values:             </p> <p>Default:           </p> <p>Description:       </p>	<p><b>Monitor Speaker Mode</b></p> <p><i>n</i> = 0, 1, 2, or 3</p> <p>1</p> <p>M0     Speaker always off.</p> <p>M1     Speaker on until carrier signal detected.</p> <p>M2     Speaker always on when modem is off-hook.</p> <p>M3     Speaker on until carrier is detected, except while dialing.</p>



**Command: Nn Modulation Handshake**

Values: *n* = 0 or 1

Default: 1

Description: N0 Modem performs handshake only at communication standard specified by **S37** and the **B** command.

N1 Modem begins handshake at communication standard specified by **S37** and the **B** command. During handshake, fallback to a lower speed can occur.

**Command: On Return Online to Data Mode**

Values: 0, 1, 3

Default: None

Description: O0 Exit online command mode and return to data mode (see **+++AT<CR>** escape sequence).

O1 Issue a retrain and return to online data mode.

O3 Issue a rate renegotiation and return to data mode.

**Command: P Pulse Dialing**

Values: P, T

Default: T

Description: Configures the modem for pulse (non-touch-tone) dialing. Dialed digits are pulsed until a **T** command or dial modifier is received.

**Command: Qn Result Codes Enable/Disable**

Values: *n* = 0 or 1

Default: 0

Description: Q0 Enable result codes.

Q1 Disable result codes.

Q2 Returns an *OK* for backward compatibility with some software.

**Command: Sr=n Set Register Value**

Values: *r* = S-register number; *n* varies

Default: None

Description: Set value of register *Sr* to value of *n*, where *n* is entered in decimal format (e.g., **S0=1**).

**Command: Sr? Read Register Value**

Values: *r* = S-register number

Default: None

Description: Read value of register *Sr* and display it in 3-digit decimal form (e.g., **S2?** gives the response *043*).

**Command: T Tone Dialing**

Values: P, T

Default: T

Description: Configures the modem for DTMF (touch-tone) dialing. Dialed digits are tone dialed until a **P** command or dial modifier is received.

**Command: Vn Result Code Format**

Values: *n* = 0 or 1

Default: 1

Description: V0 Displays result codes as digits (terse response).

V1 Displays result codes as words (verbose response).

**Command: Wn Result Code Options**

Values: *n* = 0, 1, or 2

Default: 2

Description: W0 CONNECT result code reports serial port speed, disables protocol result codes.

W1 CONNECT result code reports serial port speed, enables protocol result codes.

W2 CONNECT result code reports line speed, enables protocol result codes.

Command: **Xn** **Result Code Selection**  
 Values:  $n = 0-7$   
 Default: 4

Description: X0 Basic result codes (*CONNECT*); does not look for dial tone or busy signal.  
 X1 Extended result codes (*CONNECT 46000 V42bis*); does not look for dial tone or busy signal.  
 X2 Extended result codes with *NO DIALTONE*; does not look for busy signal.  
 X3 Extended result codes with *BUSY*; does not look for dial tone.  
 X4 Extended result codes with *NO DIALTONE* and *BUSY*.  
 X5 Extended result codes with *NO DIALTONE* and *BUSY*.  
 X6 Extended result codes with *NO DIALTONE* and *BUSY*.  
 X7 Basic result codes with *NO DIAL TONE* and *BUSY*.

Command: **Zn** **Modem Reset**  
 Values:  $n = 0$  or  $1$   
 Default: None

Description: Z0 Reset modem to profile saved by the last **&W** command.  
 Z1 Same as **Z0**.

Command: **&Cn** **Data Carrier Detect (DCD) Control**

Values:  $n = 0, 1, 2$   
 Default: 1

Description: &C0 Forces the DCD circuit to be always ON.  
 &C1 DCD goes ON when the remote modem's carrier signal is detected, and goes OFF when the carrier signal is not detected.  
 &C2 DCD turns OFF upon disconnect for time set by S18. It then goes high again (for some PBX phone systems).

Command: **&Dn** **Data Terminal Ready (DTR) Control**

Values:  $n = 0, 1, 2,$  or  $3$   
 Default: 2

Description: &D0 Modem ignores true status of DTR signal and responds as if it is always on.  
 &D1 If DTR drops while in online data mode, the modem enters command mode, issues an *OK*, and remains connected.  
 &D2 If DTR drops while in online data mode, the modem hangs up. If the signal is not present, the modem will not answer or dial.  
 &D3 If DTR drops, modem hangs up and resets as if **ATZ** command were issued.

Command: **&En** **XON/XOFF Pacing Control**

Values:  $n = 12$  or  $13$   
 Default: 12

Description: &E12 Disables XON/XOFF pacing.  
 &E13 Enables XON/XOFF pacing.

Command: **&Fn** **Load Factory Settings**

Values:  $n = 0$   
 Default: None

Description: &F0 Load factory settings as active configuration.

**Note:** See also the **Z** command.

Command: **&Gn** **V.22bis Guard Tone Control**

Values:  $n = 0, 1,$  or  $2$   
 Default: 0

Description: &G0 Disable guard tone.  
 &G1 Set guard tone to 550 Hz.  
 &G2 Set guard tone to 1800 Hz.

**Note:** The **&G** command is not used in North America.

Command:           **&Kn**           **Flow Control Selection**  
 Values:              $n = 0, 3, \text{ or } 4$   
 Defaults:            3  
 Description:        &K0 Disable flow control.  
                       &K3 Enable CTS/RTS hardware flow control.  
                       &K4 Enable XON/XOFF software flow control.

Command:           **&Ln**           **Leased Line Operation**  
 Values:              $n = 0, 1, \text{ or } 2$   
 Defaults:            0  
 Description:        &L0 The modem is set for standard dial-up operation.  
                       &L1 The modem is set for leased line operation in originate mode.  
                       &L2 The modem is set for leased line operation in answer mode.

**Note:** For **&L1** and **&L2**, there is a 30-second window between power up and the starting of the leased line handshake. During this time, you can turn off the command, if desired.

Command:           **&Pn**           **Pulse Dial Make-to-Break Ratio Selection**  
 Values:              $n = 0, 1, \text{ or } 2$   
 Default:            0  
 Description:        &P0 60/40 make-to-break ratio  
                       &P1 67/33 make-to-break ratio  
                       &P2 20 pulses per second

**Note:** The **&P2** command is available only if the country code is set to Japan.

Command:           **&Qn**           **Asynchronous Communications Mode**  
 Values:              $n = 0, 5, 6, 8, \text{ or } 9$   
 Default:            5  
 Description:        &Q0 Asynchronous with data buffering. Same as **W0**.  
                       &Q5 Error control with data buffering. Same as **W3**.  
                       &Q6 Asynchronous with data buffering. Same as **W0**.  
                       &Q8 MNP error control mode. If MNP error control is not established, the modem falls back according to the setting in **S36**.  
                       &Q9 V.42 or MNP error control mode. If neither error control is established, the modem falls back according to the setting in **S36**.

Command:           **&Sn**           **Data Set Ready (DSR) Control**  
 Values:              $n = 0 \text{ or } 1$   
 Default:            0  
 Description:        &S0 DSR is always ON.  
                       &S1 DSR goes ON only during a connection.

Command:           **&Tn**           **Loopback Test (V.54 Test) Commands**  
 Values:              $n = 0, 1, 3, 6$   
 Default:            None  
 Description:        The modem can perform selected test and diagnostic functions. A test can be run only when the modem is operating in non-error-correction mode (normal or direct mode). For tests 3 and 6, a connection between the two modems must be established. To terminate a test in progress, the escape sequence (**+++AT**) must be entered.  
                       &T0 Stops any test in progress.  
                       &T1 Starts a local analog loopback, V.54 Loop 3, test. If a connection exists when this command is issued, the modem hangs up. When the test starts, a *CONNECT* message is displayed.  
                       &T3 Starts local digital loopback, V.54 Loop 2, test. If no connection exists, *ERROR* is returned.  
                       &T6 Initiates a remote digital loopback, V.54 Loop 2, test without self-test. If no connection exists, *ERROR* is returned.

Command:	<b>&amp;V</b>	<b>Display Current Settings</b>
Values:		n/a
Description:		Displays the active modem settings.
Command:	<b>&amp;Wn</b>	<b>Store Current Configuration</b>
Values:		n = 0 or 1
Default:		1
Description:		&W0 Stores current modem settings in non-volatile memory and causes them to be loaded at power-on or following the <b>ATZ</b> command instead of the factory defaults. See <b>&amp;F</b> command. &W1 Clears user default settings from non-volatile memory and causes the factory defaults to be loaded at power-on or following the <b>ATZ</b> command.
Command:	<b>&amp;Zy=x</b>	<b>Store Dialing Command</b>
Values:		y = 0–2 (0–1SMI-Parallel (internal)) x = Dialing command
Default:		None
Description:		Stores dialing command x in memory location y. Dial the stored number using the command <b>ATDS=y</b> . See Also the <b>#CBS</b> command, a callback security command.
Command:	<b>\An</b>	<b>Select Maximum MNP Block Size</b>
Values:		n = 0, 1, 2, or 3
Default:		3
Description:		\A0 64-character maximum \A1 128-character maximum \A2 192-character maximum \A3 256-character maximum
Command:	<b>\Bn</b>	<b>Transmit Break</b>
Values:		n = 0–9 in 100 ms units
Default:		3
Description:		In non-error-correction mode only, sends a break signal of the specified length to a remote modem. Works in conjunction with the <b>\K</b> command.
Command:	<b>\Kn</b>	<b>Break Control</b>
Values:		n = 0–5
Default:		5
Description:		Controls the modem's response to a break received from: computer, remote modem, or <b>\B</b> command. Response is different for each of three different states. <b>Data mode. Modem receives the break from the computer:</b> <b>\K0</b> Enter online command mode, no break sent to the remote modem. <b>\K1</b> Clear data buffers and send break to the remote modem. <b>\K2</b> Same as <b>\K0</b> . <b>\K3</b> Send break immediately to the remote modem. <b>\K4</b> Same as <b>\K0</b> . <b>\K5</b> Send break to the remote modem in sequence with the transmitted data. <b>Data mode. Modem receives the break from the remote modem:</b> <b>\K0</b> Clear data buffers and send break to the computer. <b>\K1</b> Same as <b>\K0</b> . <b>\K2</b> Send break immediately to the computer. <b>\K3</b> Same as <b>\K2</b> . <b>\K4</b> Send break to the computer in sequence with the received data. <b>\K5</b> Same as <b>\K4</b> . <b>Online command mode. Modem receives a \Bn command from the computer:</b> <b>\K0</b> Clear data buffers and send break to the remote modem. <b>\K1</b> Same as <b>\K0</b> . <b>\K2</b> Send break immediately to the remote modem. <b>\K3</b> Same as <b>\K2</b> . <b>\K4</b> Send break to the remote modem in sequence with the transmitted data. <b>\K5</b> Same as <b>\K4</b> .

Command:	<b>\Nn</b>	<b>Error Correction Mode Selection</b>
Values:		n = 0–5, or 7
Default:		3
Description:		<p>\N0 Non-error correction mode with data buffering (buffer mode; same as <b>&amp;Q6</b>).</p> <p>\N1 Direct mode.</p> <p>\N2 MNP reliable mode. If the modem cannot make an MNP connection, it disconnects.</p> <p>\N3 V.42/MNP auto-reliable mode. The modem attempts first to connect in V.42 error correction mode, then in MNP mode, and finally in non-error correction (buffer) mode with continued operation.</p> <p>\N4 V.42 reliable mode. If the modem cannot make a V.42 connection, it disconnects.</p> <p>\N5 V.42, MNP, or non-error correction (same as <b>\N3</b>). \N7 V.42, MNP, or non-error correction (same as <b>\N3</b>).</p>
Command:	<b>\Qn</b>	<b>Flow Control Selection</b>
Values:		n = 0, 1, or 3
Default:		3
Description:		<p>\Q0 Disable flow control (same as <b>&amp;K0</b>).</p> <p>\Q1 XON/XOFF software flow control (same as <b>&amp;K4</b>).</p> <p>\Q2 CTS-only flow control. Not supported.</p> <p>\Q3 RTS/CTS hardware flow control (same as <b>&amp;K3</b>).</p>
Command:	<b>\Tn</b>	<b>Inactivity Timer</b>
Values:		n = 0, 1–255
Default:		0
Description:		<p>Sets the time (in minutes) after the last character is sent or received that the modem waits before disconnecting. A value of zero disables the timer. Applies only in buffer mode.</p> <p><b>Note:</b> You can also set the inactivity timer by changing the value of <b>S30</b>.</p>
Command:	<b>\Vn</b>	<b>Protocol Result Code</b>
Values:		n = 0, 1, or 2
Default:		1
Description:		<p>\V0 Disables the appending of the protocol result code to the DCE speed.</p> <p>\V1 Enables the appending of the protocol result code to the DCE speed.</p> <p>\V2 Same as <b>\V1</b>.</p>
Command:	<b>\Xn</b>	<b>XON/XOFF Pass-Through</b>
Values:		n = 0 or 1
Default:		0
Description:		<p>\X0 Modem responds to and discards XON/XOFF characters. \X1 Modem responds to and passes XON/XOFF characters. <b>Note:</b> This is also controlled via <b>&amp;E6</b> and <b>&amp;E7</b>.</p>
Command:	<b>-Cn</b>	<b>Data Calling Tone</b>
Values:		n = 0 or 1
Defaults:		1
Description:		<p>-C0 Disable V.25 data calling tone to deny remote data/fax/voice discrimination.</p> <p>-C1 Enable V.25 data calling tone to allow remote data/fax/voice discrimination.</p>
Command:	<b>%A</b>	<b>Adaptive Answer Result Code Enable</b>
Values:		n = 0 or 1
Default:		0
Description:		<p>The %A command controls whether the DATA or FAX result codes will be sent by the modem. The modem must be in fax mode for this command to work. Also, the modem must be set to <b>+FAA=1</b>, which enables the modem to distinguish between a fax and a data call. When these commands are enabled, the modem sends DATA to the computer when it detects data tones and FAX when it detects fax tones. These strings are used by some servers to select the appropriate communication program. %A0 Disables adaptive answer result codes.</p> <p>%A1 Enables adaptive answer result codes.</p>

Command:	<b>%B</b>	<b>View Numbers in Blacklist</b>
Values:		n/a
Description:		If blacklisting is in effect, <b>AT%B</b> displays the numbers for which the last call attempted in the previous two hours failed. In countries that do not require blacklisting, the <i>ERROR</i> result code appears.
Command:	<b>%Cn</b>	<b>Data Compression Control</b>
Values:		n = 0 or 1
Default:		1
Description:		%C0 Disable V.42bis/MNP 5 data compression. %C1 Enable V.42bis/MNP 5 data compression.
Command:	<b>%DCn</b>	<b>AT Command Control</b>
Values:		n = 0 or 1
Default:		0
Description:		%DC0 The modem responds to AT commands. %DC1 The modem ignores AT commands. <b>Note:</b> The modem will respond to <b>AT%DC</b> for 10 seconds after power-up.
Command:	<b>%En</b>	<b>Fallback and Fall Forward Control</b>
Values:		n = 0, 1, or 2
Default:		2
Description:		%E0 Disable fallback and fall forward. %E1 Enable fallback, disable fall forward. %E2 Enable fallback and fall forward.
Command:	<b>%Hn</b>	<b>Direct Connect Enable</b>
Values:		n = 0, 1
Default:		0
Description:		%H0 Sets callback security to normal operation. %H1 All callback security calls will be direct connect regardless of whether the password or phone number has the - character.
Command:	<b>%Rn</b>	<b>Cisco Configuration</b>
Values:		n = 0, 1
Default:		0
Description:		%R0 Disables Cisco configuration. %R1 Sets <b>E0, Q1, &amp;D0, VN0, \$SB9600</b> , and <b>%S1</b> for operation with a Cisco router.
Command:	<b>%Sn</b>	<b>Command Speed Response</b>
Values:		n = 0, 1
Default:		0
Description:		%S0 Sets modem to respond to AT commands at all normal speeds. %S1 AT commands accepted at 115200 bps only. Commands at other speeds are ignored.
Command:	<b>\$Dn</b>	<b>DTR Dialing</b>
Values:		n = 0 or 1
Default:		0
Description:		\$D0 Disables DTR dialing. \$D1 Dials the number in memory location 0 when DTR goes high.
Command:	<b>\$EBn</b>	<b>Asynchronous Word Length</b>
Values:		n = 0 or 1
Default:		0
Description:		\$EB0 Enables 10-bit mode. \$EB1 Enables 11-bit mode.

Command:	<b>\$MBn</b>	<b>Online BPS Speed</b>
Values:		<i>n</i> = speed in bits per second
Default:		28,800
Description:		<p>\$MB75        Selects CCITT V.23 mode</p> <p>\$MB300      Selects 300 bps on-line</p> <p>\$MB1200     Selects 1200 bps on-line</p> <p>\$MB2400     Selects 2400 bps on-line</p> <p>\$MB4800     Selects 4800 bps on-line</p> <p>\$MB9600     Selects 9600 bps on-line</p> <p>\$MB14400    Selects 14400 bps on-line</p> <p>\$MB19200    Selects 19200 bps on-line</p> <p>\$MB28800    Selects 28800 bps on-line</p> <p>\$MB33600    Selects 33600 bps on-line</p>
Command:	<b>\$RPn</b>	<b>Ring Priority vs. AT Command Priority</b>
Values:		<i>n</i> = 0 or 1
Default:		1
Description:		<p>\$RP0        The AT command will have priority over the ring. S1 will be reset to 0 if an AT command is received. This command is storable to memory.</p> <p>\$RP1        The ring will have priority over the AT command. S1 will increment even if an AT command and ring are received together and the incoming call will be answered when S1 is equal to S0. <b>Note:</b> SocketModems do not detect ring cadence of TelTone telephone line simulators as a valid ring.</p>
Command:	<b>\$SBn</b>	<b>Serial Port Baud Rate</b>
Values:		<i>n</i> = speed in bits per second
Default:		115200
Description:		<p>\$SB300       Sets serial port to 300 bps</p> <p>\$SB1 200     Sets serial port to 1200 bps</p> <p>\$SB2400      Sets serial port to 2400 bps</p> <p>\$SB4800      Sets serial port to 4800 bps</p> <p>\$SB9600      Sets serial port to 9600 bps</p> <p>\$SB1 9200    Sets serial port to 19200 bps</p> <p>\$SB38400     Sets serial port to 38400 bps</p> <p>\$SB57600     Sets serial port to 57600 bps</p> <p>\$SB1 15200   Sets serial port to 115200 bps</p> <p>\$SB230400   Sets serial port to 230400 bps</p>
Command:	<b>+VDR=x, y</b>	<b>Distinctive Ring Report</b>
Values:		<p>x = 0, 1        Distinctive Ring report control. See description.</p> <p>y = 0–255      Minimum ring interval in 100 ms units. See description.</p>
Default:		0, 0
Description:		<p>Enables reporting of ring cadence information to the DTE and specifies the minimum ring cadence that will be reported.</p> <p>The report format is one line per silence period and one line per ring period. The length of the silence period is in the form DROF=number in units of 100 ms&lt;CR&gt;&lt;LF&gt;, and the length of the ring is in the form DRON=number in units of 100 ms&lt;CR&gt; &lt;LF&gt;. The modem may produce a Ring event code after the DRON message if enabled by the y parameter. The y parameter must be set to a value equal to or smaller than the expected ring cadence in order to pass the report to the DTE.</p> <p>+VDR=0, n/a    Disables Distinctive Ring cadence reporting.</p> <p>+VDR=1, 0      Enables Distinctive Ring cadence reporting. Other call progress result codes (including RING) are reported as normal.</p> <p>+VDR=1, &gt;0    Enables Distinctive Ring cadence reporting. The RING result code is reported after the falling edge of the ring pulse (i.e., after the DRON report).</p> <p>+VDR=?         Displays the allowed values.</p> <p>+VDR?          Displays the current value.</p>



Command:	<b>#CBAn</b>	<b>Callback Attempts</b>
Values:		n = 1–255
Default:		4
Description:		Sets the number of callback attempts that are allowed after passwords have been exchanged between modems.
Command:	<b>#CBDn</b>	<b>Callback Delay</b>
Values:		n = 0–255
Default:		15
Description:		Sets the length of time (in seconds) that the modem waits before calling back the remote modem.
Command:	<b>#CBF?</b>	<b>Callback Failed Attempts Display</b>
Values:		n/a
Default:		n/a
Description:		Requests the number of failed callback passwords since reset or power-up. This number can be stored to nonvolatile memory using the <b>&amp;W</b> command.
Command:	<b>#CBFR</b>	<b>Callback Failed Attempts Reset</b>
Values:		n/a
Default:		n/a
Description:		Resets the number of failed callback passwords to 0. This does not reset the number stored in nonvolatile memory.
Command:	<b>#CBIn</b>	<b>Local Callback Inactivity Timer</b>
Values:		n = 1–255
Default:		20
Description:		Sets the time (in minutes) that the modem waits for a command before forcing the user to enter the setup password again.
Command:	<b>#CBNy=x</b>	<b>Store Callback Password</b>
Values:		y = 0–29 x = password
Defaults:		None
Description:		Sets the callback security password for the y memory location. The password must have 6 to 10 characters, and cannot include the + or - characters.
Command:	<b>#CBPn</b>	<b>Callback Parity</b>
Values:		n = 0, 1, or 2
Default:		0
Description:		Sets parity for the callback security messages. #CBP0 No parity. #CBP1 Odd parity. #CBP2 Even parity.
Command:	<b>#CBRy</b>	<b>Callback Security Reset</b>
Values:		y = 0–29
Default:		None
Description:		Clears the password and phone number in the y memory location.
Command:	<b>#CBSn</b>	<b>Callback Enable/Disable</b>
Values:		n = 0, 1, 2, or 3
Default:		0
Description:		#CBS0 Disables callback security. #CBS1 Enables local and remote callback security. #CBS2 Enables remote callback security only. #CBS3 Disables callback security until local hangup or reset.

Command:	<b>#Pn</b>	<b>Set 11-bit Parity</b>
Values:		n = 0 or 1
Default:		2
Description:		#P0 No parity. #P1 Odd parity. #P2 Even parity.
Command:	<b>#Sx</b>	<b>Enter Setup Password</b>
Values:		x= password (1–8 characters, case sensitive)
Default:		MTSMODEM
Description:		Enters the remote configuration setup password.
Command:	<b>#S=x</b>	<b>Store Setup Password</b>
Values:		x= password (1–8 characters, case sensitive)
Default:		MTSMODEM
Description:		Stores a new remote configuration setup password.

## Escape AT Commands

Command:	<b>+++AT&lt;CR&gt;</b>	<b>Escape Sequence</b>
Values:		n/a
Description:		Puts the modem in command mode (and optionally issues a command) while remaining online. Type <b>+++AT</b> and up to six optional command characters; then press ENTER. Used mostly to issue the hang-up command: <b>+++ATH&lt;CR&gt;</b> .
Command:	<b>%%%ATMTSMODEM&lt;CR&gt;</b>	<b>Remote Configuration Escape Sequence</b>
Values:		n/a
Description:		Initiates remote configuration mode while online with remote modem. The remote configuration escape character (%) is defined in register <b>S13</b> .

## V.92 Commands

Command:	<b>+MS=</b>	<b>Modulation Selection</b>
Values:		See description.
Defaults:		See description.
Description:		This extended-format command selects modulation, enables or disables automode, and specifies the highest downstream and upstream connection rates using one to four subparameters. The command syntax is <b>+MS=[mod][,[automode][,[0][,[max_rate][,[0][,[max_rx_rate]]]]]]&lt;CR&gt;</b> Subparameters that are not entered retain their current value. Commas separate optional subparameters, and must be inserted to skip a subparameter. Example: <b>+MS=,0&lt;CR&gt;</b> disables automode and keeps all other settings at their current values.
	<b>+MS=?</b>	Reports supported options in the format (list of supported mod values),(list of supported automode values),(0),(list of supported max_rate values),(0),(list of supported max_rx_rate values). Example: <b>+MS: (BELL103, V21, BELL212A, V22, V22B, V23C, V32, V32B, V34, V90, V92), (0, 1), (0), (0-33600), (0), (0- 56000)</b>
	<b>+MS?</b>	Reports current options in the format mod, automode, 0, max_rate, 0, max_rx_rate. Example: <b>+MS: V92,1, 0, 31200, 0, 56000.</b>
	<b>mod</b>	<b>Subparameters</b> Specifies the preferred modulation (automode enabled) or the modulation to use in originating or answering a connection (automode disabled). The default is V92.

<i>mod</i>	Modulation	Possible rates (bps) <sup>1</sup>							
V92 <sup>2</sup>	V92	66, 53333, 52000,	50666,	49333,	48000,	46666,	45333,	44000,	
V903	V.90	66, 53333, 52000,	50666,	49333,	48000,	46666,	45333,	44000,	
V34	V.34	33600, 31200, 28800, 26400,	24000,	21600,	19200,	16800,	14400,	12000,	
V32B	V.32bis	14400, 12000, 9600, 7200, or 4800							
V32	V.32	9600 or 4800							
V22B	V.22bis	2400 or 1200							
V22	V.22	1200							
V23C	V.23	1200							
V21	V.21	300							
Bell212A	Bell 212A	1200							
Bell103	Bell 103	300							
<b>Notes:</b>									
1. See optional <i>&lt;automode&gt;</i> , <i>&lt;max_rate&gt;</i> , and <i>&lt;max_RX_rate&gt;</i> subparameters.									
2. Selects V.92 modulation as first priority. If a V.92 connection cannot be established, the modem attempts V.90, V.34, V.32bis, etc.									

*automode* An optional numeric value that enables or disables automatic modulation negotiation using V.8 bis/V.8 or V.32 bis Annex A. Automode is disabled if values are specified for the *max\_rate* and *max\_rx\_rate* parameters. The options are:

- 0 Disable automode
- 1 Enable automode (default)

*max\_rate* An optional number that specifies the highest rate at which the modem may establish an upstream (transmit) connection. The value is decimal coded in units of bps, for example, 33600 specifies the highest rate to be 33600 bps.

- 0 Maximum rate determined by the modulation selected in *mod* (default).
- 300–33600 Maximum rate value limited by the modulation selected in *mod*. For valid *max\_rate* values for each *mod* value, see the following table.

<i>mod</i> value	Valid <i>max_rate</i> values (bps)										
V92, V90, V34	31200,	28800,	26400,	24000,	21600,	19200,	16800,	14400,	12000,	9600,	7200,
V32B	19200,	16800,	14400,	12000,	9600,	7200,	4800				
V32	14400,	12000,	9600,	7200,	4800						
V22B	2400										
V22, V23C, Bell212A	1200										
V21, Bell103	300										

*max\_rx\_rate*:

An optional number that specifies the highest rate at which the modem may establish a downstream (receive) connection. The value is decimal coded in units of bps, e.g., 28800 specifies the highest rate to be 28800 bps.

- 0 Maximum rate determined by the modulation selected in *mod* (default).
- 300–56000 Maximum rate value limited by the modulation selected in *mod*. See “Possible rates” in the *mod* table.

Command: **+PCW=n** Call Waiting Enable  
 Values: n = 0, 1, or 2  
 Default: 2

Description: Controls the action to be taken upon detection of a call waiting tone in V.92 mode. Values specified by this command are not modified when an **AT&F** command is issued.

- +PCW=0 Toggles V.24 Circuit 125 and collects Caller ID if enabled by +VCID
- +PCW=1 Hangs up
- +PCW=2 Ignores V.92 call waiting
- +PCW=? Displays the allowed values
- +PCW? Displays the current value

Command: **+PIG=n PCM Upstream Ignore**  
 Values: n = 0 or 1  
 Default: 1  
 Description: Controls the use of PCM upstream during V.92 operation. PCM upstream allows faster upload speeds to a V.92 server.

- +PIG=0 Disables PCM upstream
- +PIG=1 Enables PCM upstream
- +PIG=? Displays the allowed values
- +PIG? Displays the current value

Command: **+PMH=n Modem on Hold Enable**  
 Values: n = 0 or 1  
 Default: 1  
 Description: Controls if modem on hold procedures are enabled during V.92 operation. Normally controlled by a modem on hold program. Values specified by this command are not modified when an **AT&F** command is issued.

- +PMH=0 Enables V.92 modem on hold
- +PMH=1 Disables V.92 modem on hold
- +PMH=? Displays the allowed values
- +PMH? Displays the current value

Command: **+PMHF V.92 Modem Hook Flash**  
 Values: n/a  
 Default: n/a  
 Description: Causes the DCE to go on-hook for a specified period of time, and then return off-hook for at least a specified period of time. The specified period of time is normally one-half second, but may be governed by national regulations. "ERROR" is returned if MOH is not enabled.

Command: **+PMHR=n Modem on Hold Initiate**  
 Values: n = 0–13  
 Default: 0  
 Description: +PMHR is an action command that causes the modem to initiate MOH with the central site modem. It returns the following values to indicate what has been negotiated. Valid only if MOH is enabled and the modem is off-hook or in data mode. Otherwise, ERROR will be returned.

- +PMHR=0 Deny MOH request
- +PMHR=1 Grant MOH request with 10 second timeout
- +PMHR=2 Grant MOH request with 20 second timeout
- +PMHR=3 Grant MOH request with 30 second timeout
- +PMHR=4 Grant MOH request with 40 second timeout
- +PMHR=5 Grant MOH request with 1 minute timeout
- +PMHR=6 Grant MOH request with 2 minute timeout
- +PMHR=7 Grant MOH request with 3 minute timeout
- +PMHR=8 Grant MOH request with 4 minute timeout
- +PMHR=9 Grant MOH request with 6 minute timeout
- +PMHR=10 Grant MOH request with 8 minute timeout
- +PMHR=11 Grant MOH request with 12 minute timeout
- +PMHR=12 Grant MOH request with 16 minute timeout
- +PMHR=13 Grant MOH request with indefinite timeout
- +PMHR=? Displays the allowed values
- +PMHR? Displays the current value

Command: **+PMHT=n Modem on Hold Timer**  
 Values:  $n = 0-13$   
 Default: 0  
 Description: Determines if the modem will accept a V.92 Modem on Hold (MOH) request and will set the MoH timeout.

+PMHT=0	Deny MOH request
+PMHT=1	Grant MOH request with 10 second timeout
+PMHT=2	Grant MOH request with 20 second timeout
+PMHT=3	Grant MOH request with 30 second timeout
+PMHT=4	Grant MOH request with 40 second timeout
+PMHT=5	Grant MOH request with 1 minute timeout
+PMHT=6	Grant MOH request with 2 minute timeout
+PMHT=7	Grant MOH request with 3 minute timeout
+PMHT=8	Grant MOH request with 4 minute timeout
+PMHT=9	Grant MOH request with 6 minute timeout
+PMHT=10	Grant MOH request with 8 minute timeout
+PMHT=11	Grant MOH request with 12 minute timeout
+PMHT=12	Grant MOH request with 16 minute timeout
+PMHT=13	Grant MOH request with indefinite timeout
+PMHT=?	Displays the allowed values
+PMHT?	Displays the current value

Command: **+PQC=n Quick Connect Control**  
 Values:  $n = 0, 1, 2, \text{ or } 3$   
 Default: 3  
 Description: Controls V.92 shortened Phase 1 and Phase 2 startup procedures (Quick Connect). When line conditions are stable, quick connect results in shortened connect times; however, significant fluctuation in line conditions from call to call can cause longer connect times; thus, it may be advisable to disable quick connect.

+PQC=0	Enables Short Phase 1 and Short Phase 2 (Quick Connect)
+PQC=1	Enables Short Phase 1
+PQC=2	Enables Short Phase 2
+PQC=3	Disables Short Phase 1 and Short Phase 2
+PQC=?	Displays the allowed values
+PQC?	Displays the current value

Command: **+VCID=n Caller ID Selection**  
 Values:  $n = 0, 1, \text{ or } 2$   
 Default: 0  
 Description: Enables Caller ID detection and configures the reporting and presentation of the Caller ID data that is detected after the first ring. The reported data includes the date and time of the call, the caller's name and number, and a message. Set S0=2.

+VCID=0	Disables Caller ID
+VCID=1	Enables Caller ID with formatted data
+VCID=2	Enables Caller ID with unformatted data
+VCID=?	Displays the allowed values
+VCID?	Displays the current value

Command: **+VDR=x, y Distinctive Ring Report**  
 Values:  $x = 0, 1$  Distinctive Ring report control. See description.  
 $y = 0-255$  Minimum ring interval in 100 ms units. See description.  
 Default: 0, 0  
 Description: Enables reporting of ring cadence information to the DTE and specifies the minimum ring cadence that will be reported.

Report format is one line per silence period and one line per ring period. The length of the silence period is in the form DROF=number in units of 100 ms<CR><LF>, and the length of the ring is in the form DRON=number in units of 100 ms<CR> <LF>. The modem may produce a Ring event code after the DRON message if enabled by the y parameter. The y parameter must be set to a value equal to or smaller than the expected ring cadence in order to pass the report to the DTE.

+VDR=0, n/a Disables Distinctive Ring cadence reporting.  
 +VDR=1, 0 Enables Distinctive Ring cadence reporting. Other call progress result codes (including RING) are reported as normal.  
 +VDR=1, >0 Enables Distinctive Ring cadence reporting. RING result code is reported after falling edge of the ring pulse (after the DRON report).  
 +VDR=? Displays the allowed values.  
 +VDR? Displays the current value.

Command: **#CBAn            Callback Attempts**  
 Values: n = 1–255  
 Default: 4  
 Description: Sets the number of callback attempts that are allowed after passwords have been exchanged between modems.

Command: **#CBDn            Callback Delay**  
 Values: n = 0–255  
 Default: 15  
 Description: Sets the length of time (in seconds) that the modem waits before calling back the remote modem.

Command: **#CBF?            Callback Failed Attempts Display**  
 Values: n/a  
 Default: n/a  
 Description: Requests the number of failed callback passwords since reset or power-up. This number can be stored to nonvolatile memory using the &W command.

Command: **#CBFR            Callback Failed Attempts Reset**  
 Values: n/a  
 Default: n/a  
 Description: Resets the number of failed callback passwords to 0. This does not reset the number stored in nonvolatile memory.

Command: **#CBIn            Local Callback Inactivity Timer**  
 Values: n = 1–255  
 Default: 20  
 Description: Sets the time (in minutes) that the modem waits for a command before forcing the user to enter the setup password again.

Command: **#CBNy=x        Store Callback Password**  
 Values: y = 0–29  
 x = password  
 Defaults: None  
 Description: Sets the callback security password for the y memory location. The password must have 6 to 10 characters, and cannot include the + or - characters.

Command: **#CBPn            Callback Parity**  
 Values: n = 0, 1, or 2  
 Default: 0  
 Description: Sets parity for the callback security messages.  
 #CBP0            No parity.  
 #CBP1            Odd parity.  
 #CBP2            Even parity.

Command: **#CBRy            Callback Security Reset**  
 Values: y = 0–29  
 Default: None  
 Description: Clears the password and phone number in the y memory location.

Command:                   **#CBSn**                   **Callback Enable/Disable**  
 Values:                    n = 0, 1, 2, or 3  
 Default:                   0  
 Description:               #CBS0           Disables callback security.  
                               #CBS1           Enables local and remote callback security.  
                               #CBS2           Enables remote callback security only.  
                               #CBS3           Disables callback security until local hangup or reset.

Command:                   **#Pn**                   **Set 11-bit Parity**  
 Values:                    n = 0 or 1  
 Default:                   2  
 Description:               #P0            No parity.  
                               #P1            Odd parity.  
                               #P2            Even parity.

Command:                   **#Sx**                   **Enter Setup Password**  
 Values:                    x= password (1–8 characters, case sensitive)  
 Default:                   MTSMODEM  
 Description:               Enters the callback security setup password.

Command:                   **#S=x**                   **Store Setup Password**  
 Values:                    x= password (1–8 characters, case sensitive)  
 Default:                   MTSMODEM  
 Description:               Stores a new callback security and remote configuration setup password.

## S-Registers

Certain modem values, or parameters, are stored in memory locations called S-Registers. Use the **S** command to read or to alter the contents of S-Registers (see previous section).

Register	Unit	Range	Default	Description
<b>S0</b>	1 ring	0, 1–255	1	Sets the number of rings until the modem answers. <b>ATS0=0</b> disables auto answer completely.
<b>S1</b>	1 ring	0–255	0	Counts the rings that have occurred.
<b>S2</b>	decimal	0–127 128–255	43 (+)	Sets ASCII code for the escape sequence character. Values greater than 127 disable escape.
<b>S3</b>	decimal	0–127	13 (^M)	Sets the ASCII code for the carriage return character.
<b>S4</b>	decimal	0–127	10 (^J)	Sets the ASCII code for the line feed character.
<b>S5</b>	decimal	0–32 33–1 27	8 (^H)	Sets the ASCII code for the backspace character. Values greater than 32 disable backspace.
<b>S6</b>	seconds	2–65*	2*	Sets the time the modem waits after it goes off-hook before it begins to dial the telephone number.
<b>S7</b>	seconds	35–65*	50*	Sets the time the modem waits for a carrier signal before aborting a call. Also sets the wait for silence time for the @ dial modifier.
<b>S8</b>	seconds	0–65	2	Sets the length of a pause caused by a comma character in a dialing command.
<b>S9</b>	decimal	0, 1–127	37 (%)	Sets ASCII code for remote configuration escape character. <b>S9=0</b> disables remote configuration.
<b>S10</b>	100 ms	1–254	20	Sets how long a carrier signal must be lost before the modem disconnects.
<b>S11</b>	1 ms	50–1 50*	95*	Sets spacing and duration of dialing tones.
<b>S28</b>	decimal	0, 1–255	1	0 disables, 1–255 enables V.34 modulation.
<b>S30</b>	1 minute	0, 1–255	0	Sets the length of time that the modem waits before disconnecting when no data is sent or received. A value of zero disables the timer. See also the <b>IT</b> command



<b>S35</b>	decimal	0–1	1	0 disables, 1 enables the V.25 calling tone, which allows remote data/fax/voice discrimination.
<b>S36</b>	decimal	0–7	7	Specifies the action to take in the event of a negotiation failure when error control is selected. (See <b>S48</b> .)
<b>S37</b>	decimal	0–19	0	Sets the maximum V.34 “upstream” speed at which the modem attempts to connect.

- 0 = maximum speed
- 1 = reserved
- 2 = 1200/75 bps
- 3 = 300 bps
- 4 = reserved
- 5 = 1200 bps
- 6 = 2400 bps
- 7 = 4800 bps
- 8 = 7200 bps
- 9 = 9600 bps
- 10 = 12000 bps
- 11 = 14400 bps
- 12 = 16800 bps
- 13 = 19200 bps
- 14 = 21600 bps
- 15 = 24000 bps
- 16 = 26400 bps
- 17 = 28800 bps
- 18 = 31200 bps
- 19 = 33600 bps

**S38** decimal 0–23 1 Sets “downstream” data rate where V.90 provides rates of 28,000 to 56,000 bps in increments of 1,333 bps.

- 0 = V.90 disabled
- 1 = V.90 auto rate
- 2 = 28,000 bps
- 3 = 29,333 bps
- 4 = 30,666 bps
- 5 = 32,000 bps
- 6 = 33,333 bps
- 7 = 34,666 bps
- 8 = 36,000 bps
- 9 = 37,333 bps
- 10 = 38,666 bps
- 11 = 40,000 bps
- 12 = 41,333 bps
- 13 = 42,666 bps
- 14 = 44,000 bps
- 15 = 45,333 bps
- 16 = 46,666 bps
- 17 = 48,000 bps
- 18 = 49,333 bps
- 19 = 50,666 bps
- 20 = 52,000 bps
- 21 = 53,333 bps
- 22 = 54,666 bps
- 23 = 56,000 bps

**Upstream data rates:** Upstream V.90 data rates are 4800 to 33,600 bps in 2400 bps increments.

**S43** decimal 0–1 1 For testing and debugging only. Enables/disables V.32bis start-up auto mode operation.  
0 = disable; 1 = enable.

**S48** decimal 7 or 128 7 Enables (7) or disables (128) LAPM negotiation. The following table lists the **S36** and **S48** configuration settings for certain types of connections.

	<b>S48=7</b>	<b>S48=128</b>
S36=0, 2	LAPM or hang up	Do not use
S36=1, 3	LAPM or async	Async
S36=4, 6	LAPM, MNP, or hang up	MNP or hang up
S36=5, 7	LAPM, MNP, or async	MNP or async

<b>S89</b>	seconds	0, 5–255	10	<p>Sets the length of time in the off-line command mode before the modem goes into standby mode or “sleep mode”. A value of zero prevents standby mode; a value of 1–4 sets the value to 5. Standby mode (sleep mode or low power mode) is controlled by <b>S89</b>. It programs the number of seconds of inactivity before the modem will go to sleep. The default value is 0. A value of 0 disables standby mode. The modem will wake on an incoming ring or an AT command.</p>
<b>S108</b>	decimal	0–3, 6, 7	6	<p>Selects the 56K digital loss if using the modem through a PBX line. The default value is -6 dB loss, the value used when calling from a typical POTS line long distance.</p> <p>0 = -0 dB digital loss, no robbed-bit signaling            1 = -3 dB PBX digital loss            2 = -2 dB digital loss            3 = -3 dB digital loss            6 = -6 dB digital loss            7 = -0 dB digital loss with robbed-bit signaling</p>

## Result Codes

In command mode your modem can send responses called **Result Codes** to your computer. Result codes are used by communications programs and can also appear on your monitor.

Terse	Verbose	Description
0	OK	Command executed
1	CONNECT	Modem connected to line
2	RING	Ring signal detected
3	NO CARRIER	Carrier signal lost or not detected
4	ERROR	Invalid command
5 *	CONNECT 1200	Connected at 1200 bps
6	NO DIALTONE	No dial tone detected
7	BUSY	Busy signal detected
8	NO ANSWER	No answer at remote end
9	CONNECT 75	Connected at 75 bps
10*	CONNECT 2400	Connected at 2400 bps
11*	CONNECT 4800	Connected at 4800 bps
12*	CONNECT 9600	Connected at 9600 bps
13*	CONNECT 14400	Connected at 14400 bps
14*	CONNECT 19200	Connected at 19200 bps
18	CONNECT 57600	Connected at 57600 bps
24*	CONNECT 7200	Connected at 7200 bps
25*	CONNECT 12000	Connected at 12000 bps
28	CONNECT 38400	Connected at 38400 bps
40*	CONNECT 300	Connected at 300 bps
55*	CONNECT 21600	Connected at 21600 bps
56*	CONNECT 24000	Connected at 24000 bps
57*	CONNECT 26400	Connected at 26400 bps
58*	CONNECT 28800	Connected at 28800 bps
59*	CONNECT 31200	Connected at 31200 bps
60*	CONNECT 33600	Connected at 33600 bps
70	CONNECT 32000	Connected at 32000 bps
71	CONNECT 34000	Connected at 34000 bps
72	CONNECT 36000	Connected at 36000 bps
73	CONNECT 38000	Connected at 38000 bps
74	CONNECT 40000	Connected at 40000 bps
75	CONNECT 42000	Connected at 42000 bps
76	CONNECT 44000	Connected at 44000 bps
7	CONNECT 46000	Connected at 46000 bps
78	CONNECT 48000	Connected at 48000 bps
79	CONNECT 50000	Connected at 50000 bps

80	CONNECT 52000	Connected at 52000 bps
81	CONNECT 54000	Connected at 54000 bps
82	CONNECT 56000	Connected at 56000 bps
83	CONNECT 58000	Connected at 58000 bps
84	CONNECT 60000	Connected at 60000 bps
86	CONNECT 16800	Connected at 16800 bps
87	CONNECT 115200	Connected at 115200 bps
88	DELAYED	Delay is in effect for the dialed number
89	BLACKLISTED	Dialed number is blacklisted
90	BLACKLIST FULL	Blacklist is full
91	CONNECT 230400	Connected at 230400 bps
100	CONNECT 28000	Connected at 28000 bps
101	CONNECT 29333	Connected at 29333 bps
102	CONNECT 30666	Connected at 30666 bps
103	CONNECT 33333	Connected at 33333 bps
104	CONNECT 34666	Connected at 34666 bps
105	CONNECT 37333	Connected at 37333 bps
106	CONNECT 38666	Connected at 38666 bps
107	CONNECT 41333	Connected at 41333 bps
108	CONNECT 42666	Connected at 42666 bps
109	CONNECT 45333	Connected at 45333 bps
110	CONNECT 46666	Connected at 46666 bps
111	CONNECT 49333	Connected at 49333 bps
112	CONNECT 50666	Connected at 50666 bps
113	CONNECT 53333	Connected at 53333 bps
114	CONNECT 54666	Connected at 54666 bps
115	CONNECT 25333	Connected at 25333 bps
116	CONNECT 26666	Connected at 26666 bps

\* EC is added to these result codes when the extended result codes configuration option is enabled. EC is replaced by one of the following codes, depending on the type of error control connection:

*V42bis* – V.42 error control (LAP-M) and V.42bis data compression

*V42* – V.42 error control (LAP-M) only

*MNP5* – MNP 4 error control and MNP 5 data compression

*MNP4* – MNP 4 error control only

*NoEC* – No error control protocol).

## Appendix D: DC Power

### D.1: Assembly of the WAGO MCS DC Power Connector

**What you will need:** Small flat-blade screwdriver, Wire stripper, DC power connector kit (provided with DC models), 48 VDC power cord (See Step 2, below and Appendix D.3)

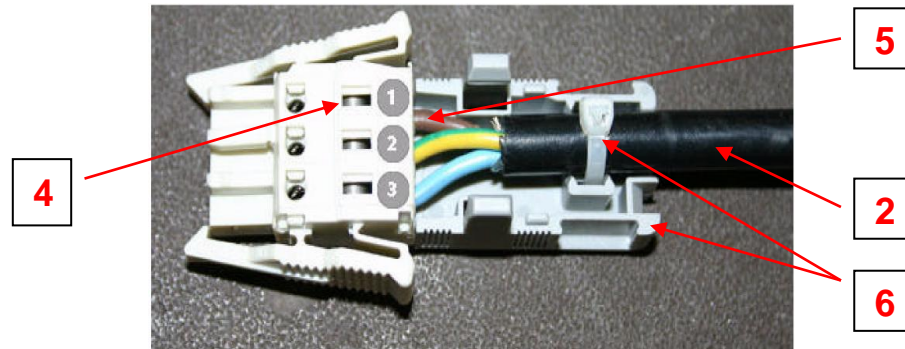

**WAGO MCS DC power connector:**

- 1. Brown = -48VDC**
- 2. Green/Yellow = Power Supply Ground**
- 3. Blue = Common**

1. Turn off the circuit breaker to the DC power supply.
2. Select a UL style 1028 or other UL 1581 (VW-1) compliant equivalent 16 AWG three-wire set (-48V, Power Supply Ground and Common).
3. Strip 0.35 inches (9 mm) of insulation from each wire.
4. Insert a small flat-blade screwdriver, one at a time, into each of the connector's clamp slots to depress the internal wire clamp.
5. Insert the appropriate wire into the connector. Remove the screwdriver. Check that the clamp has captured the wire. Repeat steps 4 and 5 for the other two wires.
6. Attach the provided strain relief to the connector. Be sure to use a tie-wrap to firmly attach the strain relief to the cable.
7. Attach the connector to the socket on the back of the Console Server. Repeat the above steps to attach each power module input

WAGO MCS DC power connector



*-48VDC Power Supply (removed from back panel)*

**Input voltage: -48VDC**

Minimum voltage: -40 VDC

Maximum voltage: -60 VDC

**Maximum operating current: 0.5A**

**The DC power source must be:**

- Electrically isolated from any AC source
- Reliably connected to earth ground
- Capable of providing up to 100 Watts of continuous power

## D.2: Over-Current Protection

Over-current protection requirements:

- 10 Amp fast trip
- Double pole
- DC rated

Over-current protection devices (e.g., circuit breakers) must be provided as part of each equipment rack and are not included with the Console Server. The device must be located between the DC power source and the Console Server.

## D.3: DC Supply Connector

The supply input *connectors* are provided with each Console Server; the *conductors* are not.

**Conductor specifications:**

- *Material:* copper only
- *Wire gauge:* 16 AWG
- *Insulation rating:* 75 °C minimum, low smoke-fume, flame retardant Branch circuit cable.
- *Insulation color:* per applicable national electrical codes.
- *Grounding cable insulation color:* green/yellow

The cable type should be one of the following:

- UL style 1028 or other UL 1581 (VW-1) compliant equivalent
- IEEE 383 compliant
- IEEE 1202-1 991 compliant

## Appendix E: Assign an IP Address to a Device Port

Version 1.7-9 of the SCS software can assign an IP address to the SCS's device ports. The user can use `ssh` to access a port directly without having to first login to the SCS. If DNS is used to give names to each address it becomes easier to associate device ports with the corresponding server.

To do this, modify the `openSSH` server code. The SCS ships with the original `ssh` code installed and running. Several steps are taken to use the modified `ssh` program and to assign addresses to the device ports. There is a README file called: `/usr/local/doc/README.lsisshd` that explains the steps to use the feature.

The steps are:

1. Run a `makefile` to replace the original `ssh` with our modified version
2. Edit the configuration file that defines the IP addressing
3. Run a `makefile` that creates the IP configuration

## Appendix F: Adapter Pin-Outs

The following pages show the pin-out drawings for the adapters which are supplied in the accessory kit with each Console Server.

**KIT-000001 contains:**

ADP-000005, ADP-000006, ADP-000007, ADP-000008, ADP-000009, ADP-000010, ADP-000011, ADP-000012

**ADP-000005 RJ45 to 25-pin Male**  
**ADP-000006 RJ45 to 25-pin Female**

**Wire key:**

- 1-Blue
- 2-Orange
- 3-Black
- 4-Red
- 5-Green
- 6-Yellow
- 7-Brown
- 8-White

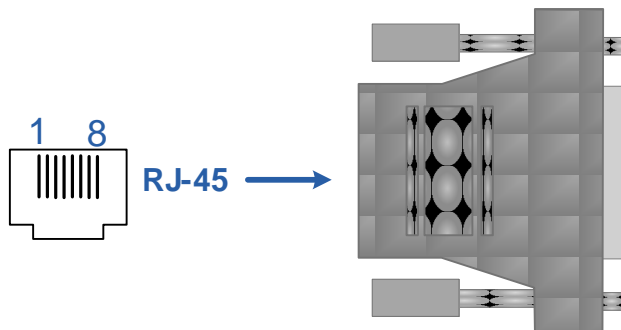
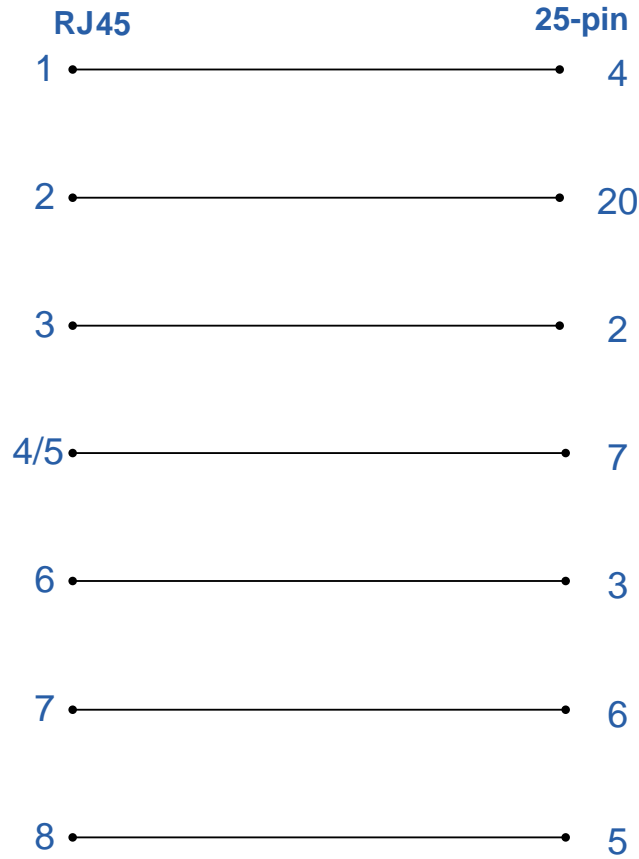



**ADP-00007-R RJ45 to DB9 Male**  
**ADP-00008-R RJ45 to DB9 Female**

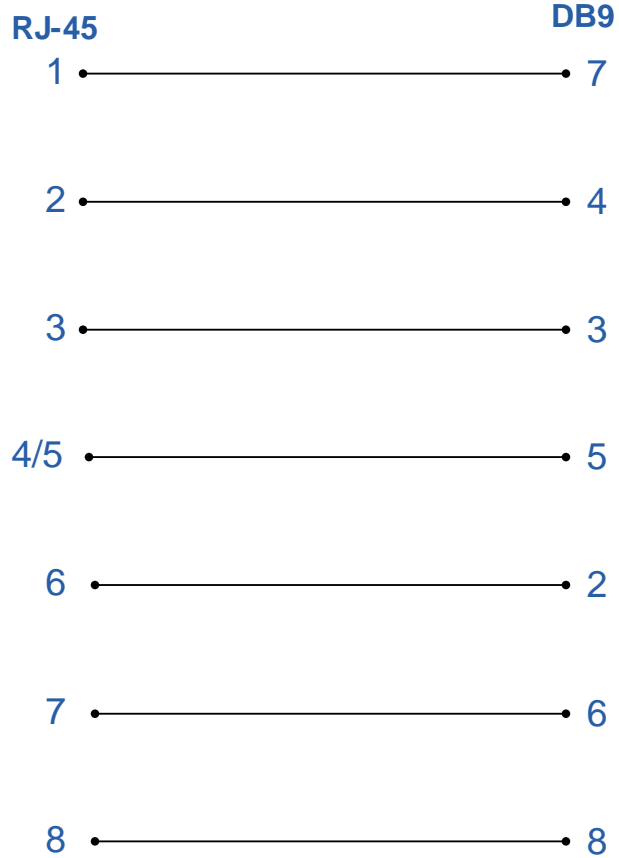

**Wire key:**

- 1-Blue
- 2-Orange
- 3-Black
- 4-Red
- 5-Green
- 6-Yellow
- 7-Brown
- 8-White

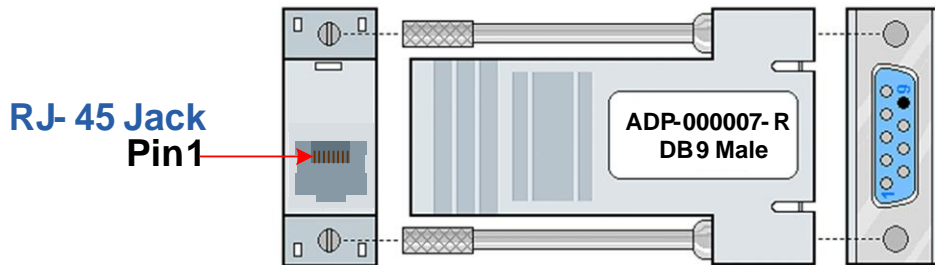

**ADP-000009 RJ45 to 25-pin Male**  
**ADP-000010 RJ45 to 25-pin Female**

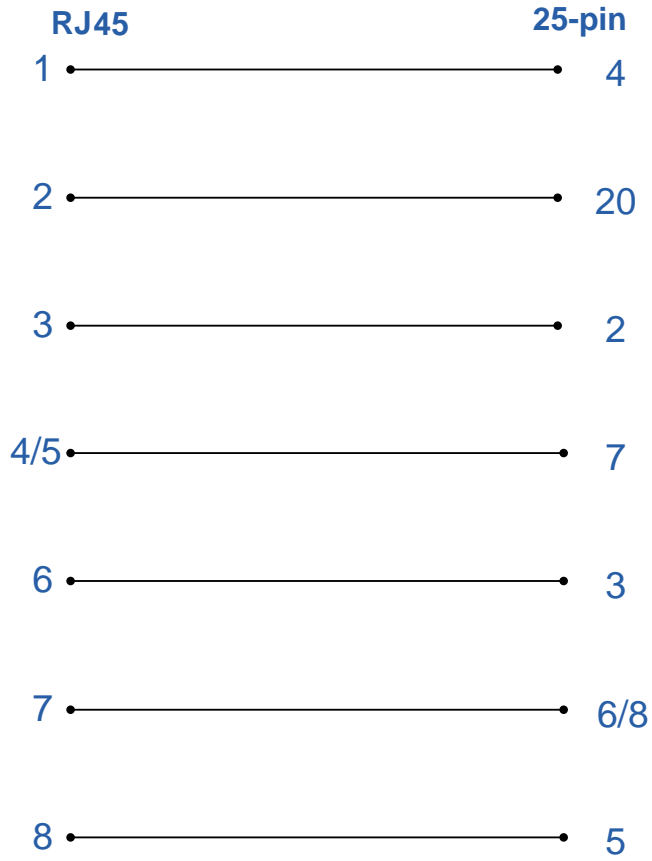

**Wire key:**

- 1-Blue
- 2-Orange
- 3-Black
- 4-Red
- 5-Green
- 6-Yellow
- 7-Brown
- 8-White

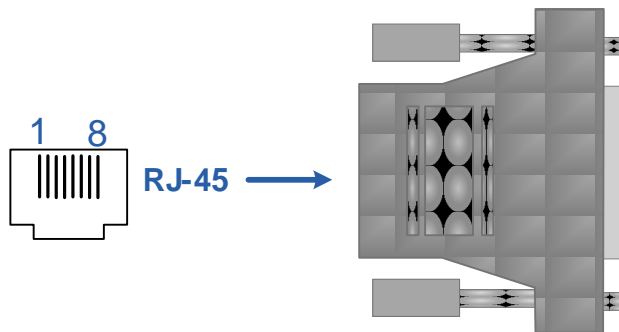

**ADP-000011-R RJ45 to DB9 Male**  
**ADP-000012-R RJ45 to DB9 Female**

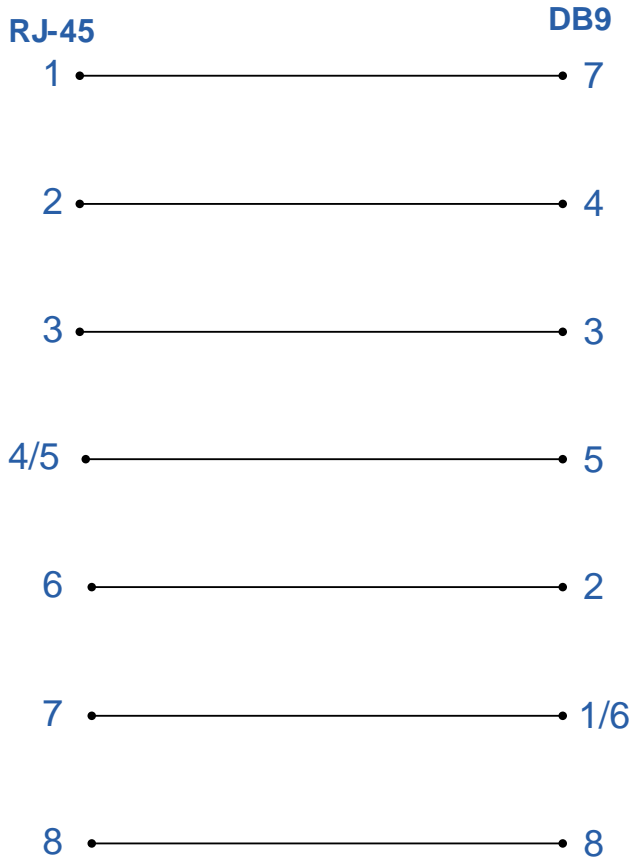

**Wire key:**

- 1-Blue
- 2-Orange
- 3-Black
- 4-Red
- 5-Green
- 6-Yellow
- 7-Brown
- 8-White

**RJ-45 Jack**  
**Pin1**

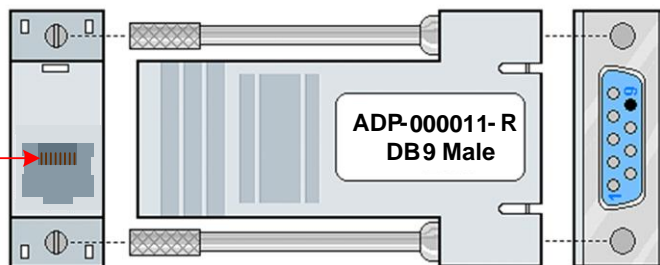

## Appendix G: Quick Start Guide

### SECURE CONSOLE SERVER QUICK START GUIDE

SCS, SCS-R and Sentinel 32 Models

Standard Models:	
SCS80 & SCS80R:	8 Ports
SCS160 & SCS160R:	16 Ports
SCS320 & SCS320R:	32 Ports
SCS480 & SCS480R:	48 Ports
Sentinel 32:	32 Ports

- All models are available with the following options:
- AC or DC power (SCSxx0 or SCSxx1)
  - dual hot-swappable redundant Power Supplies (SCSxxxR)
  - dual Console Port Interfaces – 1 DTE, 1 DCE (SCSxxx-D)
  - 32-bit CardBus (SCSxxx-C)
  - Modem (SCSxxx-M)



The core of *Thinklogical's™* Secure Console Server is an x86-based computer running *GNU/Linux*. In addition, the SCS has built in technologies such as 4 GB Compact Flash Drive and support for plug-compatible micro drives. Upon setup the SCS generates a unique set of Secure Shell Host (SSH) keys, a crucial security feature lacking in some traditional console servers. Also featured is a full distribution, non-embedded *Linux* operating system. The SCS is the only console server on the market that is able to integrate into existing system and configuration management software programs. This enables users to customize the capacity of the SCS, as well as its level of integration into their particular environment. In addition, users are able to match security technology to fit their processes while modifying and enhancing features to meet their specifications.

**Contents (SCS AC):**  
Secure Console Server  
Rack Mount Brackets  
AC Power Cord (PWR-000006-R)  
Adapter Kit (KIT-000001-R)  
Adapter Kit (KIT-000003-R)  
Users' Manual CD

**Contents (SCS DC):**  
Secure Console Server  
Rack Mount Brackets  
Adapter Kit (KIT-000001-R)  
Adapter Kit (KIT-000003-R)  
Users' Manual CD

**STEP 1:** Connect to the Network with a CAT5 cable.

**STEP 2:** (Optional) Connect to the Console with a CAT5 cable.

**STEP 3:** Ensure that the ON/OFF switch is in the OFF (0) position. Connect the supplied AC Power Cord and plug it into a standard AC source.

**STEP 4:** Switch the unit ON (1). The initial startup takes about 2 minutes to generate the predefined ssh host keys. The boot progress is displayed on the front panel LCD.

**STEP 5:** Verify port connections.

*Thinklogical's™* SCS-R series of Secure Console Servers provides server and network management as well as secure console and integrated power management with enterprise-class security features. Unique to this line of console servers are the **redundant AC and DC power supplies** that function in a current sharing mode. The SCS-R power supplies are also **hot-swappable**, enabling users to remove a failed power supply while the unit is operating. In addition, users can access and control any combination of serial devices (servers, LAN/WAN devices, routers, workstations, etc.) through dual console and network ports.

**Contents (SCS-R & Sentinel AC):**  
Secure Console Server  
Rack Mount Brackets  
2 AC Power Cords (PWR-000006-R)  
AC 'Y' Power Cord (PWR-000008-R)  
Adapter Kit (KIT-000001-R)  
Adapter Kit (KIT-000003-R)  
Users' Manual CD

**Contents (SCS-R & Sentinel -48VDC):**  
Secure Console Server  
Rack Mount Brackets  
Adapter Kit (KIT-000001-R)  
Adapter Kit (KIT-000003-R)  
Users' Manual CD

**STEP 1:** Connect to Networks 1 and/or Network 2 with CAT5 cable.

**STEP 2:** (Optional) Connect to Console 1 and/or Console 2 with CAT5 cable.

**STEP 3:** Ensure that both ON/OFF switches are in the OFF (0) position. Connect the supplied AC Power Cords and plug them into a standard AC source.

**STEP 4:** Put both switches in the ON (1) position. The initial startup takes about 2 minutes to generate the predefined ssh host keys. The boot progress is displayed on the front panel LCD.

**STEP 5:** Verify port connections.

**All of the Sentinel 32's hot-swappable modules are designed for easy field replacement. Replace serial ports in groups of 8 without affecting any of the other ports.**

#### Setting Up Via the Network

- Have the following Network addresses ready:
  - Your workstation/PC's IP address (If the SCS is using Dynamic Host Configuration Protocol (DHCP) addressing, nothing more is required.)
  - If assigning a static address to the SCS, the following are required: IP address, Network mask, Gateway address, Primary Domain Name System (DNS) server address.
- Settings
  - Create a route from your workstation/PC to the SCS default IP address of 10.9.8.7
    - Linux: `route add -net 10.9.8.7 netmask 255.255.255.255 gw <PC IP address>`
    - Windows command line: `route add 10.9.8.7 mask 255.255.255.255 <PC IP address>`
    - Solaris: `route add -net 10.9.8.7 -netmask 255.255.255.255.0 <PC IP address>`
- Run `timeonfig` if you are not in the Eastern Time Zone.
- Run `netconfig` to set the SCS network parameters for Network 1 (eth0). Network 2 is disabled. See on-line documentation to enable Network 2.
  - From a console connection run `service network restart`
  - From a SSH connection run `service network restart && exit` (You will then have to restart your SSH session.)
- Use the `stty` command to change things like port names, baud rates, etc. These are temporary changes and will be lost at reboot. To make permanent changes, edit `/etc/rc.d/rc.serial`. This file contains a list of `stty` commands (one for each port). Further information is available in the User's Manual (CD provided).

#### \*Using Secure Shell Host (SSH)

You must use SSH to connect to the SCS. From the command line, run the following: `ssh root@10.9.8.7`

#### Documentation

*Thinklogical™* uses *Linux man* (short for manual) pages to document its software. The command `man 1 lsi` will list user commands. The command `man 8 lsi` will list the administrator commands and `man 5 lsi` will list the various configuration files. Individual command documentation can be accessed via `man xxx` where `xxx` is the command. Examples: `man ls`, `man tar`, `man lsd`, `man adduser`

#### User Commands

- The commands `connect` and `monitor` allow the user to use a short version of the port names. You may use just the port number (1 through 48) or leave off `/lsi/ports/`
- Connect `<portname or number>`
  - `connect 5`
  - `connect port5`
  - `connect /lsi/ports/port5`
  - `connect /dev/tty/B5`

**Note:** To exit `connect`, the default key sequence is 'Esc A'.
- Monitor `<portname or number>`
  - `monitor 5`
  - `monitor port5`
  - `monitor /lsi/ports/port5`
  - `monitor /dev/tty/B5`
- Browsing the port buffers
  - `less /lsi/ports/buf_port5`
  - `less /proc/port_buffers/5`
  - `more </proc/port_buffers/7`
- `help` is available for all SCS commands via `man` pages. The command `man -a lsi` will bring up an overview of the SCS commands and files.
- Several HOWTO's covering system setup and configuration can be found at `/usr/local/doc`

#### Setting Up the Serial Console

- Serial Console Settings 9600, N, 8, 1
- Login as root. The password is root.
  - Note:** Console Port 1 is in Data Circuit-terminating Equipment (DCE) mode. Console Port 2 is in Data Terminal Equipment (DTE) mode and is not enabled for logins. To use Console Port 2 the system administrator must enable it. Port 2 is activated by editing the `/etc/inittab` file.

#### \*Testing Port Connections

The command `pm` can be used to verify device port connections. `pm --all` will test all ports and report the correct DTE/DCE settings.

Copyright © 2010. All rights reserved. Printed in the U.S.A. All trademarks and service marks are the property of their respective owners. Secure\_Console\_Server\_Manual\_Quick\_Start\_Per\_A