

SHARP SERVICE MANUAL

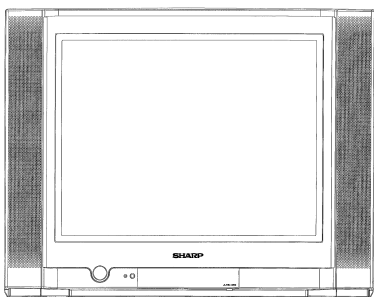

No. S75L821JFG1RU

COLOUR TELEVISION *Chassis No. GA-4M*

MODEL 21J-FG1RU

In the interests of user-safety (Required by safety regulations in some countries) the set should be restored to its original condition and only parts identical to those specified should be used.

FEATURES

- Multi 18 Systems
- Full Auto Channel Preset and Auto Channel Skip
- 100-CH Program Memory
- CATV (Hyper Band) Ready
<Used Frequency Synthesizer Tuner>
- Black Stretch Circuit
- On Timer / Off Timer / Reminder Timer
- Blue Back Function
- Front AV IN & Rear AV IN / OUT Terminals
- Front Headphone Jack
- Aperture Control Circuit
- Auto Fine Tuning
- NTSC Colour Comb Filter (AV THRU)
- High Contrast Picture
- Hotel Mode
- Russian and English Languages OSD
- White Temperature Select
- Component In
- Surround Sound Effect
(With Bass / Treble / Balance)
- AV Stereo

CONTENTS

CHAPTER 1. SPECIFICATIONS

[1] SPECIFICATIONS 1-1

CHAPTER 2. IMPORTANT SERVICE NOTES

[1] IMPORTANT SERVICE NOTES 2-1

CHAPTER 3. ADJUSTMENT PRECAUTIONS

[1] ADJUSTMENT PRECAUTIONS 3-1

[2] ADJUSTMENT 3-14

CHAPTER 4. MEMORY MAP

[1] MEMORY MAP 4-1

CHAPTER 5. TROUBLE SHOOTING FLOWCHART

[1] TROUBLE SHOOTING FLOWCHART 5-1

CHAPTER 6. SOLID STATE DEVICE BASE DIAGRAM

[1] SOLID STATE DEVICE BASE DIAGRAM..... 6-1

CHAPTER 7. CHASSIS LAYOUT

[1] CHASSIS LAYOUT 7-1

CHAPTER 8. BLOCK DIAGRAM

[1] BLOCK DIAGRAM: CRT UNIT 8-1

[2] BLOCK DIAGRAM: HEADPHONE UNIT..... 8-1

[3] BLOCK DIAGRAM: MAIN UNIT 8-2

CHAPTER 9. DESCRIPTION OF SCHEMATIC DIAGRAM

[1] DESCRIPTION OF SCHEMATIC DIAGRAM..... 9-1

CHAPTER 10. WAVEFORM

[1] WAVEFORMS 10-1

CHAPTER 11. SCHEMATIC DIAGRAM

[1] SCHEMATIC DIAGRAM: MAIN UNIT..... 11-1

[2] SCHEMATIC DIAGRAM: CRT UNIT 11-3

[3] SCHEMATIC DIAGRAM: HEADPHONE UNIT 11-3

CHAPTER 12. PRINTED WIRING BOARD ASSEMBLIES

[1] PWB-B: CRT UNIT 12-1

[2] PWB-C: HEADPHONE UNIT 12-1

[3] PWB-A: MAIN UNIT 12-2

Parts Guide

WARNING

The chassis in this receiver is partially hot. Use an isolation transformer between the line cord plug and power receptacle, when servicing this chassis. To prevent electric shock, do not remove cover. No user - serviceable parts inside. Refer servicing to qualified service personnel.

CHAPTER 2. IMPORTANT SERVICE NOTES

[1] IMPORTANT SERVICE NOTES

Maintenance and repair of this receiver should be done by qualified service personnel only.

1. SERVICE OF HIGH VOLTAGE SYSTEM AND PICTURE TUBE

When servicing the high voltage system, remove static charge from it by connecting a 10K ohm resistor in series with an insulated wire (such as a test probe) between picture tube dag and 2nd anode lead. (AC line cord should be disconnected from AC outlet.)

- 1) Picture tube in this receiver employs integral implosion protection.
- 2) Replace with the same type number of picture tube for continued safety.
- 3) Do not lift picture tube by the neck.
- 4) Handle the picture tube only when wearing shatterproof goggles and after discharging the high voltage completely.

2. X-RAY

This receiver is designed so that any X-Ray radiation is kept to an absolute minimum. Since certain malfunctions or servicing may produce potentially hazardous radiation with prolonged exposure at close range, the following precautions should be observed:

- 1) When repairing the circuit, please make sure do not increase the high voltage of the set to more than 30.0kV (at beam 0 μ A).
- 2) To keep the set in a normal operation, please make sure it's function at 26.5kV \pm 0.5kV (at beam 1,000 μ A). The set has been factory - adjusted to the above-mentioned high voltage.
*If there is a possibility that the high voltage fluctuates as a result of the repairs, never forget to check for such high voltage after the work.
- 3) Do not substitute a picture tube with unauthorized types and/or brands which may cause excessive X-ray radiation.

3. BEFORE RETURNING THE RECEIVER

Before returning the receiver to the user, perform the following safety checks.

- 1) Inspect all lead dress to make certain that leads are not pinched or that hardware is not lodged between the chassis and other metal parts in the receiver.
- 2) Inspect all protective devices such as non-metal control knobs, insulating materials, cabinet backs, adjustment and compartment covers or shields, isolation resistor-capacity networks, mechanical insulators etc.

CHAPTER 3. ADJUSTMENT PRECAUTIONS

[1] ADJUSTMENT PRECAUTIONS

This model's settings are adjusted in two different ways: through the I2C bus control and in the conventional analog manner. The adjustments via the I2C bus control include preset-only items and variable data.

CAUTION: Make sure TV set in "Normal condition" before switch to Service Mode for adjustment.

1. Setting the service mode by the microprocessor.

- i) Press SERVICE key on the remote controller to set the TV set to SERVICE mode position, and the microprocessor is in input mode. (Adjustment through the I2C bus control).
- ii) Press the MENU key on the remote controller to get ready to select the mode (Adjustment mode, Setting mode, Check mode and Option mode) one by one.
- iii) Press the CH DOWN / UP key on the remote controller to select the item in Adjustment mode, Setting mode or Option mode.
- iv) Using the VOLUME UP/ DOWN key on the remote controller, the data can be modified. Please wait approximately 200 msec for data storage in EEPROM before select to another mode.
- v) In Check mode the data cannot be changed.
- vi) Press the SERVICE key again, it will switch to the NORMAL mode position, and the microprocessor is out of the SERVICE mode.

2. Factory Presetting.

- i) Power ON the TV set, press the SERVICE key on the remote controller, then press both the CH UP and VOL UP button on the set simultaneously for 5secs. Initial values are automatically preset, only when a new EEPROM is used.
- ii) The initial data are preset as listed in page 3-7 to 3-12.
- iii) Make sure the data need modification or not (Initial data).

Precaution: If haven't done this initialization, it may possibly generate excessive Beam current.

3. For reference please check with memory map RH-IXB226WJZZ (See Page 4-1 ~ 4-16)

1. ADJUSTMENT ITEM

***Below are the adjustment items that should be done, PLS FOLLOW THE PROCEDURE. Otherwise some adjustment items will not be accurate.

NO ***	ADJUSTMENT ITEM	EFFECTIVE MODEL	REVISION
1	BUS SET UP	21J-FG1RU	
2	OPTION SET UP		
3	H-VCO		
4	VIF-VCO		
5	S-TRAP fo		
6	RF-AGC		
7	PURITY ADJ		
8	CONVERGENCE ADJ		
9	FOCUS ADJ		
10	V-SHIFT (50 Hz)		
11	H-SHIFT (50 Hz)		
12	V-SIZE (50 Hz)		
13	SCREEN		
14	WHITE BALANCE		
15	SUB-BRIGHTNESS		
16	SUB-CONTRAST		
17	SUB-TINT		
18	SUB-COLOR		
19	SECAM-OFFSET		
20	SIF VCO ADJ		
21	BEAM CURRENT CHECK		
22	BEAM PROTECTOR CHECK		
23	HV PROTECTOR CHECK		
24	OTHER PROTECTOR CHECK		
25	AV OUT CHECK		
26	AV IN CHECK		
27	COMPONENT IN CHECK		
28	CONTRAST CONTROL CHECK		
29	COLOR CONTROL CHECK		
30	BRIGHTNESS CONTROL CHECK		
31	TINT CONTROL CHECK		
32	SHARPNESS CONTROL CHECK		
33	CH DISPLAY COLOR CHECK		
34	NORMAL DISPLAY CHECK		
35	WHITE TEMP CONTROL CHECK		
36	COLOR SYSTEM CHECK		
37	SURROUND CHECK		
38	TREBLE CHECK		
39	BASS CHECK		
40	BALANCE CHECK		
41	SOUND SYSTEM CHECK		
42	NOISE MUTE CHECK		
43	OSD LANGUAGE QUANTITY CHECK		
44	HEAD PHONE CHECK		
45	SHOCK TEST CHECK		

2. USER DATA IN SERVICE MODE

- 1) While SERVICE mode ON, EEPROM DATA will switch to the service data. Also, once SERVICE mode OFF, EEPROM will switch back to previous USER DATA.
- 2) In the service mode, the user data establish as below,

	USER DATA
CONTRAST	MAX (60)
COLOUR	CENT (0)
BRIGHTNESS	CENT (0)
TINT	CENT (0)
SHARPNESS	CENT (0)
WHITE TEMP	STANDARD
S-VOLUME	MIN
SURROUND	OFF
TREBLE	CENT (0)
BASS	CENT (0)
BALANCE	CENT (0)
BLUE BACK	OFF
C SYSTEM	AUTO
S SYSTEM	*1

*1: For each CH, data is same as before switch to Service mode.

The flow of Mode list as following,

* Direct Key-in Mode for Service Items in Service Mode

RC CODE (HEX)	R/C KEY NAME	SERVICE-ITEM
80	POS 1	R-C UP (IN SERVICE MODE V00)
40	POS 2	G-C UP (IN SERVICE MODE V00)
C0	POS 3	B-C UP (IN SERVICE MODE V00)
20	POS 4	R-C DOWN (IN SERVICE MODE V00)
A0	POS 5	G-C DOWN (IN SERVICE MODE V00)
60	POS 6	B-C DOWN (IN SERVICE MODE V00)
E0	POS 7	R-D UP (IN SERVICE MODE V00)
10	POS 8	B-D UP (IN SERVICE MODE V00)
50	POS 0	B-D DOWN (IN SERVICE MODE V00)
E4	FLASHBACK	R-D DOWN (IN SERVICE MODE V00)
E4	FLASHBACK	Y-MUTE (BESIDES OF SERVICE MODE V00)
75	WHITE TEMP UP	RF-AGC (V01)
F5	WHITE TEMP DOWN	VIF-VC0 (V02)
C2	TUNE DOWN	H-VCO (V03)
8D	SHARPNESS DOWN	SUB-CON (V04)
D6	BALANCE LEFT	SUB-COL (V05)
0D	SHARPNESS UP	SUB-BRIGHT (V06)
36	BALANCE RIGHT	SUB-TINT (V07)
46	TREBLE UP	SUB-SHP (V08)
C6	TREBLE DOWN	SUB-COL-YUV (V09)
26	BASS UP	SUB-TINT-YUV (V10)
24	COLOUR UP	V-SIZE (V11), V-SIZE60 (V17)
54	BRIGHTNESS DOWN	V-SHIFT (V12), V-SHIFT60 (V18)
74	TINT DOWN	H-SHIFT (V13), H-SHIFT60 (V19)
66	SURROUND UP	SCM-BR (V14)
E6	SURROUND DOWN	SCM-BB (V15)
C4	CONTRAST DOWN	SUB-VOL (V16)
4C	PICTURE	S-TRAP-BG (V20)
CC	HOLD	S-TRAP-I (V21)
2C	TEXT	S-TRAP-DK (V22)
AC	CANCEL	S-TRAP-M (V23)
EC	SIZE	S-TRAP-574 (V24)
80	POS 1	R-C UP YUV (IN SERVICE MODE V25)
40	POS 2	G-C UP YUV (IN SERVICE MODE V25)
C0	POS 3	B-C UP YUV (IN SERVICE MODE V25)
20	POS 4	R-C DOWN YUV (IN SERVICE MODE V25)

RC CODE (HEX)	R/C KEY NAME	SERVICE-ITEM
A0	POS 5	G-C DOWN YUV (IN SERVICE MODE V25)
60	POS 6	B-C DOWN YUV (IN SERVICE MODE V25)
E0	POS 7	R-D UP YUV (IN SERVICE MODE V25)
10	POS 8	B-D UP YUV (IN SERVICE MODE V25)
50	POS 0	B-D DOWN YUV (IN SERVICE MODE V25)
E4	FLASHBACK	R-D DOWN YUV (IN SERVICE MODE V25)
C1		AUTO ADJ FOR V01, V02, V03, V20, V21, V22, V23, V24
CA		T-SET
81		SERVICE MODE

1) Please set the MCL to MCL1 as below.

2) After set the MCL , please set the INITIAL SETTING.

INITIAL 5: For Russia (All Channel Sound System are set to D/K)

MCL1 (HEX AE)		
CH-No	Fv (MHz)	Sound Sys
0		
1	48.25	B/G
2	62.25	B/G
3	77.25	D/K
4	175.25	B/G
5	182.25	B/G
6	183.25	D/K
7	191.25	D/K
8	196.25	B/G
9	199.25	M
10	210.25	B/G
11	224.25	B/G
12	471.25	B/G
13	487.25	I
14	503.25	B/G
15	575.25	B/G
16	583.25	B/G
17	599.25	B/G
18	621.25	M
19	639.25	D/K
20	703.25	B/G
21	735.25	I
22	767.25	B/G
23	815.25	B/G
24	855.25	I
25	855.25	B/G
26	55.25	M
27	83.25	M
28	183.25	M
29	193.25	M
30	217.25	M
31	471.25	M
32	477.25	M
33	693.25	M
34	885.25	M
35	112.25	B/G
36	168.25	B/G
37		
38	294.25	B/G
39	463.25	B/G
40		
41	647.25	B/G
42	663.25	B/G
43	679.25	B/G
44	174.95	B/G
45	175.55	B/G

MCL1 (HEX AE)		
CH-No	Fv (MHz)	Sound Sys
46		
47		
48		
49		
50		
51		
52		
53		
54		
55		
56		
57		
58		
59		
60		
61		
62		
63		
64		
65		
66		
67		
68		
69		
70		

NOTE: PLL DATA OF ABOVE FREQ SHOULD TAKE THE ACCOUNT OF PIF SETTING IN SERVICE OPTION 004 (VIF) BEFORE STORING INTO EEPROM

3. SHIPPING SETTING & CHECKING

1) The following default data has been factory-set for the E2PROM follow by INITIAL DATA selected.

ITEMS	DATA SETTING
LAST POWER	ON
LAST TV/AV MODE	TV MODE
LAST POSITION	CH 1
FLASHBACK CHANNEL	CH 1
1/2 DIGIT ENTRY	2 DIGIT ENTRY
VOLUME	0 (Min)
BLUE BACK	OFF
OFF TIMER	--:--
ON TIMER	--:--
ON TIMER POSITION	--
ON TIMER VOLUME	--
REMINDER	--:--
AFT	ALL CH ON
COLOR SYSTEM	ALL CH AUTO
SKIP	ALL CH OFF
CONTRAST	60
COLOR	0
BRIGHTNESS	0
TINT	0
SHARPNESS	0
WHITE TEMP	0
SURROUND	OFF
TREBLE	0
BASS	0
BALANCE	0(CENTER)

INITIAL	LANGUAGE	SOUND SYSTEM
1	CHINESE	D/K
2	CHINESE	I
3	ENGLISH	B/G
4	ARABIC	B/G
5	RUSSIAN	D/K
6	MALAY	B/G
7	FRENCH	D/K

FACTORY SETTING BY MODEL

(Reference: Geomagnetism Adjustment)

MODEL	MAGNETIC FIELD(V, H) nT	BACKGROUND	LANG.	S-SYS	LANG QTY	
RUSSIA	45000	20000	7500°K	RUSSIAN	D/K	2

*NOTE FOR OSD TYPE:

2: ENGLISH/RUSSIAN

21J-FG1RU

**AFTER INITIALIZED THE EEPROM (REFER TO FACTORY PRESETTING), READ DATA FROM EEPROM ADDRESS 00H ~ 03H, AND COMPARE TO THE LIST BELOW, IF DIFFERENT, INITIALIZE THE EEPROM.

ADDRESS	DATA	ADDRESS	DATA
00H:	7BH	02H:	72H
01H:	72H	03H:	76H

*** There are four stages of service mode data. First stage data from V00~V31 (Adjustment Mode).

To go into second stage of service mode data, press MENU key. Second stage data from F01~F142 (Setting Mode).

To go into third stage of service mode data, press MENU key. Third stage data is Check Mode.

To go into fourth stage of service mode data, press MENU key. Fourth stage data from O01~O31 (Option Mode).

ADJUSTMENT MODE (FIRST STAGE)					
EEPROM ITEMS	OSD	DATA LENGTH	INITIAL DATA	FIX/ADJ/AUTO	REMARK
R-DRIVE	V00	0~127	63	ADJ	PLS REFER TO ADJ ITEM FOR SCREEN AND WHITE BALANCE
B-DRIVE	V00	0~127	63	ADJ	
R-CUT	V00	0~255	127	ADJ	
G-CUT	V00	0~255	127	ADJ	
B-CUT	V00	0~255	127	ADJ	
RF-AGC	V01	0~127	50	AUTO	
VIF-VCO	V02	0~63	31	AUTO	
H-VCO	V03	0~7	3	AUTO	
SUB-CONTRAST	V04	0~127	100	ADJ	
SUB-COLOR	V05	0~127	63	ADJ	
SUB-BRIGHT	V06	0~255	127	ADJ	
SUB-TINT	V07	0~127	63	ADJ	
SUB-SHARPNESS	V08	0~63	43	*FIX	BUS SETUP
SUB-COLOR -YUV	V09	0~127	90	*FIX	BUS SETUP
SUB-TINT-YUV	V10	0~127	63	FIX	
V-SIZE 50 Hz	V11	0~63	38	ADJ	
V-SHIFT 50 Hz	V12	0~7	3	ADJ	
H-SHIFT 50 Hz	V13	0~31	9	ADJ	
SECAM-BR	V14	0~63	37	ADJ	
SECAM-BB	V15	0~63	22	ADJ	
SUB-VOL	V16	0~60	60	FIX	
V-SIZE 60 Hz	V17	-31~0~+31	0	FIX	IF NECESSARY, ADJ
V-SHIFT 60 Hz	V18	-7~0~+7	-1	FIX	IF NECESSARY, ADJ
H-SHIFT 60 Hz	V19	-15~0~+15	+2	FIX	IF NECESSARY, ADJ
S-TRAP (BG)	V20	0~15	7	AUTO	
S-TRAP (I)	V21	0~15	7	AUTO	
S-TRAP (DK)	V22	0~15	7	AUTO	
S-TRAP (M)	V23	0~15	7	AUTO	
S-TRAP (5.74)	V24	0~15	7	AUTO	
CUTOFF/BKGD YUV	V25				
R-DRI YUV	V25	0~127	63	FIX	
B-DRI YUV	V25	0~127	63	FIX	
R-CUT YUV	V25	0~255	127	FIX	
G-CUT YUV	V25	0~255	127	FIX	
B-CUT YUV	V25	0~255	127	FIX	
SUB-CON YUV	V26	0~127	100	FIX	
SUB-BRGHT YUV	V27	0~255	127	FIX	
VS-CORRECT	V28	0~63	32	FIX	ONLY FOR M61266
VC-CORRECT OFFSET	V29	-13~+13	0	FIX	ONLY FOR M61266
V LINEARITY	V30	0~63	32	FIX	ONLY FOR M61266
V LINEARITY OFFSET	V31	-13~+13	0	FIX	ONLY FOR M61266

SETTING MODE (SECOND STAGE)						
EEPROM ITEMS	FUNCTION	OSD	DATA LENGTH	INITIAL DATA	FIX/ADJ/AUTO	REMARK
C.CLIP-LVL	CLIP LEVEL CONTRAST CONTROL OF RGB INPUT	F01	0(20H) / 1(40H)	0	FIX	
RGB-CLIP	CLIPPING OF RGB CONTRAST CONTROL	F02	0 (CLIP OFF) / 1(CLIP ON)	0	FIX	
BS	BLACK STRETCH	F03	0(ON) / 1(OFF)	0	FIX	
ABCL	ABCL PROCESSING (ACL PROCESSING)	F04	0(OFF) / 1(ON)	0	FIX	
ABCL-GAIN	ABCL PROCESSING GAIN	F05	0(LOW) / 1(HIGH)	0	FIX	
S-OUT-LVL	AUDIO OUTPUT GAIN CONTROL	F06	0~127	95	FIX	
VIF-G	P-IF DETECTION GAIN OUTPUT	F07	0~7	4	FIX	
SHPG	SHARPNESS GAIN	F08	0(NORMAL) / 1(HIGH)	0	FIX	
SHPG-P	SHARPNESS GAIN PAL	F09	0(NORMAL) / 1(HIGH)	0	FIX	
SHPG-S	SHARPNESS GAIN SECAM	F10	0(NORMAL) / 1(HIGH)	0	FIX	
SHPG-N4	SHARPNESS GAIN N443	F11	0(NORMAL) / 1(HIGH)	0	FIX	
SHPG-N3	SHARPNESS GAIN N358	F12	0(NORMAL) / 1(HIGH)	1	FIX	
YDL	Y SIGNAL DELAY	F13	0~7	5	FIX	
YDL-P	Y SIGNAL DELAY PAL	F14	0~7	5	FIX	
YDL-S	Y SIGNAL DELAY SECAM	F15	0~7	7	FIX	
YDL-N4	Y SIGNAL DELAY N443	F16	0~7	5	FIX	
YDL-N3	Y SIGNAL DELAY N358	F17	0~7	5	FIX	
YDL-AV	Y SIGNAL DELAY AV	F18	0~7	6	FIX	
YDL-AV-P	Y SIGNAL DELAY PAL (AV)	F19	0~7	6	FIX	
YDL-AV-S	Y SIGNAL DELAY SECAM (AV)	F20	0~7	7	FIX	
YDL-AV-N4	Y SIGNAL DELAY N443 (AV)	F21	0~7	6	FIX	
YDL-AV-N3	Y SIGNAL DELAY N358 (AV)	F22	0~7	6	FIX	
YDL-YUV	Y SIGNAL DELAY YUV	F23	0~7	6	FIX	
COL-AV (OFFSET)	COLOUR OFFSET AV	F24	-31~0~+31	+10	FIX	
COL-P (OFFSET)	COLOUR OFFSET PAL	F25	-31~0~+31	0	FIX	
COL-S (OFFSET)	COLOUR OFFSET SECAM	F26	-31~0~+31	+9	FIX	
COL-N4 (OFFSET)	COLOUR OFFSET N443	F27	-31~0~+31	-8	FIX	
COL-N3 (OFFSET)	COLOUR OFFSET N358	F28	-31~0~+31	-7	FIX	
COL-ADJ (OFFSET)	COLOUR OFFSET ADJUST	F29	-31~0~+31	0	FIX	
SHP-AV (OFFSET)	SHARPNESS OFFSET AV	F30	-31~0~+31	+5	*FIX	BUS SETUP
SHP-YUV (OFFSET)	SHARPNESS OFFSET YUV	F31	-31~0~+31	0	FIX	
SHP-P (OFFSET)	SHARPNESS OFFSET PAL	F32	-31~0~+31	0	FIX	
SHP-S (OFFSET)	SHARPNESS OFFSET SECAM	F33	-31~0~+31	-5	FIX	
SHP-N4 (OFFSET)	SHARPNESS OFFSET N443	F34	-31~0~+31	0	FIX	
SHP-N3 (OFFSET)	SHARPNESS OFFSET N358	F35	-31~0~+31	0	FIX	
TINT-AV (OFFSET)	TINT OFFSET AV	F36	-63~0~+63	0	FIX	
TINT-ADJ (OFFSET)	TINT OFFSET ADJUST	F37	-63~0~+63	0	FIX	
TINT-YUV-ADJ (OFFSET)	TINT YUV OFFSET ADJUST	F38	-63~0~+63	0	FIX	
R-R (OFFSET)	R-DRIVE OFFSET WHEN WHITE TEMP IS RED	F39	-63~0~+63	+8	FIX	
B-R (OFFSET)	B-DRIVE OFFSET WHEN WHITE TEMP IS RED	F40	-63~0~+63	-10	FIX	
R-B (OFFSET)	R-DRIVE OFFSET WHEN WHITE TEMP IS BLUE	F41	-63~0~+63	-3	FIX	
B-B (OFFSET)	B-DRIVE OFFSET WHEN WHITE TEMP IS BLUE	F42	-63~0~+63	+13	*FIX	BUS SETUP
TRAP	CENTER VALUE OF CHROMA TRAP	F43	0~3	2	FIX	
TRAP-P	CENTER VALUE OF CHROMA TRAP PAL	F44	0~3	2	FIX	
TRAP-S	CENTER VALUE OF CHROMA TRAP SECAM	F45	0~3	2	FIX	
TRAP-N4	CENTER VALUE OF CHROMA TRAP N443	F46	0~3	2	FIX	
TRAP-N3	CENTER VALUE OF CHROMA TRAP N358	F47	0~3	2	FIX	
1W-TV	VERT SYNC DETECTION MODE FOR AV (1 WINDOW/2 WINDOW)	F48	ACCEPTABLE PERIOD: 0(AUTOMATIC CHANGE) / 1(FIX (WIDE))	0	FIX	

SETTING MODE (SECOND STAGE)						
EEPROM ITEMS	FUNCTION	OSD	DATA LENGTH	INITIAL DATA	FIX/ADJ/AUTO	REMARK
1W-AV	VERT SYNC DETECTION MODE FOR TV (1 WINDOW/2 WINDOW)	F49	ACCEPTABLE PERIOD: 0(AUTOMATIC CHANGE) / 1(FIX (WIDE))	1	FIX	
V-FREE (NO SYNC)	SET VERTICAL TO FORCED FREE RUN MODE	F50	0(NORMAL) / 1(FRE-ERUN)	0	FIX	
AFC2 (NO SYNC)	HORIZONTAL AFC2 GAIN	F51	0(NORMAL) / 1(DOWN)	0	FIX	
GAMMA	GAMMA CORRECTION QTY	F52	0~3	0	FIX	
BS-D/C	BLACK STRETCH CONTROL LEVEL	F53	0~15	10	FIX	
BS-GAIN	BLACK STRETCH LEVEL	F54	0(NORMAL) / 1(DOWN)	0	FIX	
OM-DET	OVER MODULATION DETECT	F55	0(OFF) / 1(ON)	0	FIX	
SL-TV	SLICE LEVEL OF SYNC DETECTION TV	F56	0~7	2	FIX	
SL-AV	SLICE LEVEL OF SYNC DETECTION AV	F57	0~7	4	FIX	
SL-YUV	SLICE LEVEL OF SYNC DETECTION YUV	F58	0~7	4	FIX	
VD2/VD1/AS/FBP-TV	VD2 & VD1-VERT SYNC DETECT MIN WIDTH MSB & LSB RESPECTIVELY, AS-TV/AV/YUV SWITCH & CH CHANGE, FBP-FLYBACK PULSE SLICE LEVEL (TV)	F59	0~15	6	FIX	
VD2/VD1/AS/FBP-AV	VD2 & VD1-VERT SYNC DETECT MIN WIDTH MSB & LSB RESPECTIVELY, AS-TV/AV/YUV SWITCH & CH CHANGE, FBP-FLYBACK PULSE SLICE LEVEL (AV)	F60	0~15	14	FIX	
VD2/VD1/AS/FBP-YUV	VD2 & VD1-VERT SYNC DETECT MIN WIDTH MSB & LSB RESPECTIVELY, AS-TV/AV/YUV SWITCH & CH CHANGE, FBP-FLYBACK PULSE SLICE LEVEL (YUV)	F61	0~15	14	FIX	
VDL	COLOUR DIFF. INPUT PHASE ADJ	F62	0~3	0	FIX	
UDL	COLOUR DIFF. INPUT PHASE ADJ	F63	0~3	0	FIX	
AUTO-SCM-KIL-TV	SECAM COLOUR KILLER SENSITIVITY (TV)	F64	0~3	1	FIX	
SECAM-BGP	INTERNAL SECAM BGP TIMING	F65	0~3	0	FIX	
N45	INHIBIT 50Hz NTSC 4.43	F66	0(NORMAL) / 1(INHIBIT)	0	FIX	
TXT-POS-H (TELETEXT)	TELETEXT HORIZONTAL POSITION	F67	0~63	30	FIX	
TXT-POS-V (TELETEXT)	TELETEXT VERTICAL POSITION	F68	0~63	34	FIX	
OSD-POS	OSD POSITION	F69	0~127	9	FIX	
CP	CHARGE PUMP	F70	0(FAST TUNING) / 1(MODERATE SPEED TUNING)	1	FIX	
SMALL-SURR (S-CTRL)	SURROUND MODE SELECT	F71	0(EALA EFFECT LARGE) / 1(EALA EFFECT SMALL)	0	FIX	
SUB-BASS (S-CTRL)	SUB BASS CONTROL	F72	0(0dB), 1(-1dB), 2(-2dB), 3(-3dB), 4(0dB), 5(+1dB), 6(+2dB), 7(+3dB)	6	*FIX	BUS SETUP
SUB-TREB (S-CTRL)	SUB TREBLE CONTROL	F73	0(0dB), 1(-1dB), 2(-2dB), 3(-3dB), 4(0dB), 5(+1dB), 6(+2dB), 7(+3dB)	0	*FIX	BUS SETUP
AGC-ADJ (S-CTRL)	AGC LEVEL ADJUST	F74	0(AGC Off), 1(300mVrms), 2(400mVrms), 3(500Vrms), 4(600mVrms)	0	*FIX	BUS SETUP
AGC-SW-OFF (NICAM)	NICAM AGC SWITCH OFF	F75	0(DISABLE, FIX GAIN), 1(ENABLE)	1	FIX	
AGC-GAIN-ADJ (NICAM)	NICAM AGC GAIN ADJUST	F76	0~31	16	FIX	
FM-LEVEL-ADJ (NICAM)	FM LEVEL ADJUST	F77	-15~0~+15	0	FIX	
IGR-LEVEL-ADJ (NICAM)	IGR LEVEL ADJUST	F78	-15~0~+15	+1	FIX	
NICAM-BG-LVL-ADJ (NICAM)	NICAM B/G LEVEL ADJUST	F79	-15~0~+15	-2	FIX	
NICAM-I-LVL-ADJ (NICAM)	NICAM I LEVEL ADJUST	F80	-15~0~+15	+3	FIX	
NICAM-DK-LVL-ADJ (NICAM)	NICAM D/K LEVEL ADJUST	F81	-15~0~+15	-1	FIX	

SETTING MODE (SECOND STAGE)						
EEPROM ITEMS	FUNCTION	OSD	DATA LENGTH	INITIAL DATA	FIX/ADJ/AUTO	REMARK
NICAM-LOW-ERR-LIM (NICAM)	NICAM LOWER ERROR LIMIT	F82	0~255	35	FIX	
NICAM-UPP-ERR-LIM (NICAM)	NICAM UPPER ERROR LIMIT	F83	0~255	70	FIX	
IGR-GAIN-ADJ (IGR)	IGR GAIN ADJUST	F84	-6~0~+7	0	FIX	
FM-ID-SPEED (NICAM)	FM SOUND IDENTIFICATION MODE	F85	0(SLOW) / 1(MEDIUM) / 2(FAST) / 3(OFF)	1	FIX	
NICAM-AUTO-MUTE	NICAM AUTO DETECTION	F86	0(MUTE) / 1(DEMUTE)	0	FIX	
AUTO-SCM-KIL-AV-YUV	SECAM COLOUR KILLER SENSITIVITY (AV/YUV)	F87	0~3	1	FIX	
AFC1-GAIN-TV	MSB OF HORIZONTAL AFC GAIN1 (TV)	F88	0(NORMAL) / 1(x2) / 2(x1.5) / 3(3.5)	0	FIX	
AFC1-GAIN-AV	MSB OF HORIZONTAL AFC GAIN1 (AV)	F89	0(NORMAL) / 1(x2) / 2(x1.5) / 3(3.5)	3	FIX	
AFC1-GAIN-YUV	MSB OF HORIZONTAL AFC GAIN1 (YUV)	F90	0(NORMAL) / 1(x2) / 2(x1.5) / 3(3.5)	3	FIX	
CON-REDUCE	CONTRAST (PICTURE LEVEL) CONTROL	F91	0(0%)~1(25%)~2(50%)	0	FIX	
TAKE-OFF-TV	TAKEOFF/BPF OF CHROMA BPF PROCESSING TV	F92	0(BPF) / 1(TAKEOFF)	1	FIX	
TAKE-OFF-AV	TAKEOFF/BPF OF CHROMA BPF PROCESSING AV	F93	0(BPF) / 1(TAKEOFF)	0	FIX	
TAKE-OFF-YUV	TAKEOFF/BPF OF CHROMA BPF PROCESSING YUV	F94	0(BPF) / 1(TAKEOFF)	0	FIX	
C-ANGLE (103 DEG/ 95 DEG)	CHROMA MODULATION ANGLE	F95	0(103DEG) / 1(95DEG)	1	FIX	
AC-FAIL-WO-BRIGHT	PICTURE BLACK LEVEL (BRIGHT) CONTROL - AC FAILURE	F96	0~255	255	FIX	
FORCED-SCM-KIL-TV	FORCED SECAM COLOUR KILLER SENSITIVITY (TV)	F97	0~3	2	FIX	
FORCED-SCM-KIL-AV-YUV	FORCED SECAM COLOUR KILLER SENSITIVITY (AV/YUV)	F98	0~3	2	FIX	
R-Y ADJ.	COLOUR EDGE IMPROVEMENT	F99	0(DISABLE) / 1(ENABLE)	1	FIX	
V-DEMUTE-DELAY	VIDEO DEMUTE DELAY	F100	0~255	0	*FIX	BUS SETUP
S-DEMUTE-DELAY	SOUND DEMUTE DELAY	F101	0~255	0	*FIX	BUS SETUP
MER	S-BOOSTER FREQ. CHARACTERISTIC CONTROL	F102	0~255	70	FIX	
MEL1	S-BOOSTER LEVEL1	F103	0~255	150	FIX	
MEL2	S-BOOSTER LEVEL2	F104	0~255	156	FIX	
MEL3	S-BOOSTER LEVEL3	F105	0~255	163	FIX	
MEL4	S-BOOSTER LEVEL4	F106	0~255	165	FIX	
MEL5	S-BOOSTER LEVEL5	F107	0~255	170	FIX	
MEL6	S-BOOSTER LEVEL6	F108	0~255	180	FIX	
S-ST-POINT	S-BOOSTER START POINT	F109	0~60	21	FIX	
S-SP-POINT	S-BOOSTER STOP POINT	F110	0~60	60	FIX	
S-STEP	S-BOOSTER STEP	F111	0~60	7	FIX	
POW-STORAGE	CONTRAST/BRIGHTNESS INCREASE GRADUALLY	F112	0(DISABLE) / 1(ENABLE)	1	FIX	
S-B-BASS	S-BOOSTER BASS LIMITER (WHEN S-BOOSTER ON)	F113	-30~0~+30	+15	FIX	
S-B-TREB	S-BOOSTER TREBLE LIMITER (WHEN S-BOOSTER ON)	F114	-30~0~+30	+15	FIX	
S-BASS	S-BOOSTER BASS LIMITER (WHEN S-BOOSTER OFF)	F115	-30~0~+30	+30	FIX	
S-TREB	S-BOOSTER TREBLE LIMITER (WHEN S-BOOSTER OFF)	F116	-30~0~+30	+30	FIX	
V-STD-TV	VERTICAL STANDARD SIGNAL DETECTOR SWITCH (TV)	F117	0(DISABLE) / 1(ENABLE)	0	FIX	
V-STD-AV	VERTICAL STANDARD SIGNAL DETECTOR SWITCH (AV)	F118	0(DISABLE) / 1(ENABLE)	0	FIX	
V-STD-YUV	VERTICAL STANDARD SIGNAL DETECTOR SWITCH (YUV)	F119	0(DISABLE) / 1(ENABLE)	0	FIX	
WO-Bright-after-WO-TIME	WHITE OUT BRIGHT AFTER WHITE OUT TIME	F120	0~255	255	FIX	
WO-Contrast-after-WO-TIME	WHITE OUT CONTRAST AFTER WHITE OUT TIME	F121	0~127	127	FIX	

SETTING MODE (SECOND STAGE)						
EEPROM ITEMS	FUNCTION	OSD	DATA LENGTH	INITIAL DATA	FIX/ADJ/AUTO	REMARK
WO-Bright-before-WO-TIME	WHITE OUT BRIGHT BEFORE WHITE OUT TIME	F122	0~255	255	FIX	
WO-Contrast-before-WO-TIME	WHITE OUT CONTRAST BEFORE WHITE OUT TIME	F123	0~127	127	FIX	
WO-TIME	WHITE OUT	F124	0~31	0	FIX	
A2-ID-Response	SETTING IDENTIFICATION RESPONSE TIME	F125	0(NORMAL) / 1(FAST)	1	FIX	
R-DRI YUV OFFSET	RGB OUTPUT RED GAIN OFFSET (YUV)	F126	-63~0~+63	0	*FIX	BUS SETUP
B-DRI YUV OFFSET	RGB OUTPUT BLUE GAIN OFFSET (YUV)	F127	-63~0~+63	0	*FIX	BUS SETUP
R-CUT YUV OFFSET	RGB OUTPUT-RED BIAS LEVEL OFFSET (YUV)	F128	-63~0~+63	0	*FIX	BUS SETUP
G-CUT YUV OFFSET	RGB OUTPUT-GREEN BIAS LEVEL OFFSET (YUV)	F129	-63~0~+63	0	*FIX	BUS SETUP
B-CUT YUV OFFSET	RGB OUTPUT-BLUE BIAS LEVEL OFFSET (YUV)	F130	-63~0~+63	0	FIX	
CON YUV OFFSET	SUB-CONTRAS OFFSET (YUV)	F131	-63~0~+63	0	FIX	
BRT YUV OFFSET	SUB-BRIGHT OFFSET (YUV)	F132	-63~0~+63	0	*FIX	BUS SETUP
SHP ANT-ONII OFFSET	SHARP ANT-ON II OFFSET FOR VIDEO TONE	F133	-31~0~+31	0	FIX	
WAIT MD TIME	SETTING CYCLE PROCESS TIME AT LOW POWER	F134	0~4	2	FIX	
Contrast OFFSET	CONTRAST (PICTURE LEVEL) OFFSET	F135	-63~0~+63	0	FIX	
Bright OFFSET	PICTURE BLACK LEVEL (BRIGHT) OFFSET	F136	-63~0~+63	0	FIX	
CR-PEDESTEL-ADJ	Cr SIGNAL LEVEL ADJUSTMENT	F137	0~15	8	FIX	ONLY FOR M62166
CB-PEDESTEL-ADJ	Cb SIGNAL LEVEL ADJUSTMENT	F138	0~15	8	FIX	ONLY FOR M62166
SIF-PAL	SOUND S/N SWITCH FOR PAL	F139	0(DISABLE) / 1(ENABLE)	0	FIX	ONLY FOR M62166
AV2 BRIGHTNESS OFFSET	AV2 BRIGHT OFFSET	F140	-15~0~+15	+7	FIX	
BASS OFFSET	BASS OFFSET	F141	-30~0~+30	0	FIX	
TREBLE OFFSET	TREBLE OFFSET	F142	-30~0~+30	0	FIX	

OPTION MODE (FOURTH STAGE)				
EEPROM ITEMS	OSD	DATA LENGTH	INITIAL DATA	REMARK
***HOTEL MODE	O01	0 (OFF) / 1 (ON)	0	OPTION SET UP
***HTL-POS	O02	0~99,--	--	OPTION SET UP
***HTL-VOL	O03	0~60,--	--	OPTION SET UP
VIF	O04	0 (38.0) / 1 (38.9)	1	OPTION SET UP
SECAM	O05	0 (DISABLE) / 1 (ENABLE)	1	OPTION SET UP
N443(RF)	O06	0 (DISABLE) / 1 (ENABLE)	1	OPTION SET UP
N358(RF)	O07	0 (DISABLE) / 1 (ENABLE)	1	OPTION SET UP
FORCE-COL	O08	0 (DISABLE) / 1 (ENABLE)	0	OPTION SET UP
S-SYS	O09	1(BG ONLY)~15(ALL)	15	OPTION SET UP
AV	O10	0 (DISABLE) / 1 (ENABLE)	1	OPTION SET UP
AV2	O11	0 (DISABLE) / 1 (ENABLE)	1	OPTION SET UP
YUV	O12	0 (DISABLE) / 1 (ENABLE)	1	OPTION SET UP
S-CTRL	O13	0 (DISABLE) / 1 (ENABLE)	1	OPTION SET UP
NICAM	O14	0 (DISABLE) / 1 (ENABLE)	0	OPTION SET UP
A2	O15	0 (DISABLE) / 1 (ENABLE)	0	OPTION SET UP
TELETEXT	O16	0 (DISABLE) / 1 (ENABLE)	0	OPTION SET UP
BILINGUAL	O17	0 (DISABLE) / 1 (ENABLE)	0	OPTION SET UP
LANGUAGE	O18	1~255	63	OPTION SET UP
SEARCH-SPEED	O19	1(350)~2(450)~3(550)~4(650)~5(750)	3	OPTION SET UP
R/C-MENU	O20	0 (ENABLE) / 1 (DISABLE)	0	OPTION SET UP
LED-CONT	O21	0 (ONE LED) / 1 (TWO LED)	0	OPTION SET UP
S-BOOSTER	O22	0 (DISABLE) / 1 (ENABLE)	0	OPTION SET UP
SHARP-LOGO	O23	0 (DISABLE) / 1 (ENABLE)	0	OPTION SET UP
YUV BKGD ADJ	O24	0 (DISABLE) / 1 (ENABLE)	0	OPTION SET UP
WHITE BACK	O25	0 (DISABLE) / 1 (ENABLE)	1	OPTION SET UP
BOOSTER	O26	0 (DISABLE) / 1 (ENABLE)	0	OPTION SET UP
****MESSAGE	O27	0 (DISABLE) / 1 (ENABLE)	0	OPTION SET UP
****MESSAGE SCROLL TIME	O28	Message Display Timing	0	OPTION SET UP
LNA TUNER	O29	0(Alps) / 1(Matsushita)	0	OPTION SET UP
ONE CHIP IC	O30	0(M61260 & M61262) / 1(M61266)	0	OPTION SET UP
MESSAGE INPUT TIMMING	O31	0~4	2	OPTION SET UP

***** HOTEL MODE**

OPERATION OF HOTEL MODE:

WHEN CHANGE SERVICE DATA O01 TO 1, HOTEL MODE IS ON

WHEN HOTEL MODE IS ON,

1. Max volume data is determined by option setting HTL-VOL (O03)
2. Channel position after POWER ON is determined by option setting HOTEL-POS (O02) (if option setting HOTEL-POS is not set, processing is according to last position data).
3. User data updates of EEPROM regarding the video and audio control is not allowed.
4. Preset mode is disable.
5. CH SETTING menu is not available.

4. ADJ ITEM: BUS SET UP (1 ST & 2ND STAGE SERVICE DATA)

SERVICE ITEMS		21J-FG1RU
V08	SUB-SHARPNESS	46
V09	SUB-COLOR YUV	105
F30	SHP-AV	+1
F42	B-B (OFFSET)	+16
F72	SUB-BASS (S-CTRL)	0
F73	SUB-TREB (S-CTRL)	3
F74	AGC-ADJ (S-CTRL)	3
F100	V-DEMUTE-DELAY	25
F101	S-DEMUTE-DELAY	40
F126	R-DRI YUV OFFSET	-1
F127	B-DRI YUV OFFSET	-3
F128	R-CUT YUV OFFSET	+14
F129	G-CUT YUV OFFSET	+35
F132	BRT YUV OFFSET	-27

5. ADJ ITEM: OPTION SET UP (4TH STAGE SERVICE DATA)

SERVICE ITEMS		21J-FG1RU
O01	HTL MODE 0 (OFF) / 1 (ON)	0
O02	HTL-POS 0>99,--	--
O03	HTL-VOL 0>60,--	--
O04	VIF 0 (38.0) / 1 (38.9)	1
O05	SECAM 0 (DISABLE) / 1 (ENABLE)	1
O06	N443(RF) 0 (DISABLE) / 1 (ENABLE)	1
O07	N358(RF) 0 (DISABLE) / 1 (ENABLE)	0
O08	FORCE-COL 0 (DISABLE) / 1 (ENABLE)	0
O09	S-SYS 1(BG ONLY)>15(ALL)	7
O10	AV 0 (DISABLE) / 1 (ENABLE)	1
O11	AV2 0 (DISABLE) / 1 (ENABLE)	1
O12	YUV 0 (DISABLE) / 1 (ENABLE)	1
O13	S-CTRL 0 (DISABLE) / 1 (ENABLE)	1
O14	NICAM 0 (DISABLE) / 1 (ENABLE)	0
O15	A2 0 (DISABLE) / 1 (ENABLE)	0
O16	TEXT 0 (DISABLE) / 1 (ENABLE)	0
O17	BIL 0 (DISABLE) / 1 (ENABLE)	0
O18	LANG 1>255	9
O19	SEARCH-SP 1(350)>2(450)>3(550)>4(650)>5(750)	3
O20	R/C MENU 0 (ENABLE) / 1 (DISABLE)	0
O21	LED-CONT 0 (ONE LED) / 1 (TWO LED)	0
O22	S-BOOSTER 0 (DISABLE) / 1 (ENABLE)	0
O23	SHARP-LOGO 0 (DISABLE) / 1 (ENABLE)	0
O24	YUV BKGD ADJ 0 (DISABLE) / 1 (ENABLE)	0
O25	WHITE BACK 0 (DISABLE) / 1 (ENABLE)	0
O26	BOOSTER 0 (DISABLE) / 1 (ENABLE)	0
O27	MESSAGE 0 (DISABLE) / 1 (ENABLE)	0
O28	MESSAGE SCROLL TIME 0 > 20	0
O29	LNA TUNER 0(Alps) / 1(Matsushita)	0
O30	ONE CHIP IC 0(M61260<FmSdata>[amp JM61262) / 1(M61266)	0
O31	MSG IN TM	2

[2] ADJUSTMENT

ADJUSTMENT PRECAUTION: Make sure TV Set is in "Normal Condition" before switch to Service Mode for Adjustment.

1. PIF ADJUSTMENT

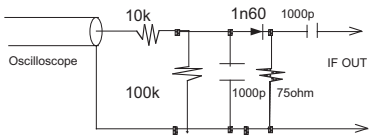
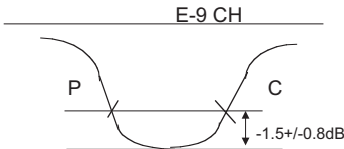
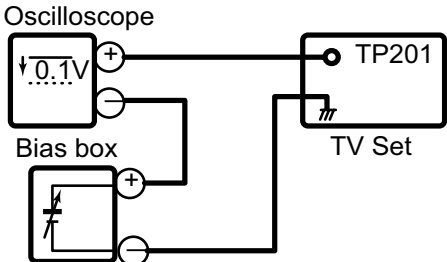
No.	Adjustment point	Adjustment procedure/conditions	Waveform and others
1	<p>Tuner IFT (PRESET)</p>	<ol style="list-style-type: none"> 1. Get the tuner ready to receive the CH. E - 9 signal, but with no signal input. Adjust the PLL data. 2. Connect the sweep generator's output cable to the tuner antenna. (RF SWEEP) 3. Adjust the sweep generator's to 80dBμV. 4. Connect the response lead (use LOW IMPEDANCE probe with wave detector ; see Fig.1) to the tuner's IF output terminal. (This terminal must have the probe alone connected). 5. Set the RF AGC to 0 - 6 V with no saturation with the waveform. 6. Adjust the tuner IF coil to obtain the waveform as shown in Fig. 2. <p>Note: Be sure to keep the tuner cover in position during this adjustment.</p>	 <p>Fig.1</p>  <p>Fig.2</p>
2	<p>RF-AGC TAKE OVER POINT ADJUSTMENT (I²C BUS CONTROL)</p> <p>(AUTO & MANUAL ADJ)</p>	<ol style="list-style-type: none"> 1. Receive "PAL COLOUR BAR" signal. <ul style="list-style-type: none"> • Signal Strength: 56 \pm 1 dBμV (75 ohm open) 2. Connect the oscilloscope to TP201 (Tuner's AGC Terminal) as shown in Fig. 3-1. <div data-bbox="570 1094 1015 1354" data-label="Diagram">  <p>• Bias box: About 4.5 V</p> </div> 3. Call "V01" mode in service mode. Adjust the "V01" bus data to obtain the Tuner output pin drop 0.1~1.0V below maximum voltage. 4. Change the antenna input signal to 63~67dBμV, and make sure there is no noise. 5. Turn up the input signal to 90~95 dBμV to be sure that there is no cross modulation beat. 	<p>* for Auto ADJ</p> <ol style="list-style-type: none"> 1) Receive "PAL COLOUR BAR" signal. signal strength: 56 \pm 1dBμV(75 ohm open) 1) Go to service mode. 2) Go to service data V01, press R/C to operate auto key (Hex C1) and confirm the 'OK' display on the screen. 3) If appear NG, increase data some step and pls repeat step 2. 4) Proceed step 4 & 5 in manual mode.

2. PURITY ADJUSTMENT

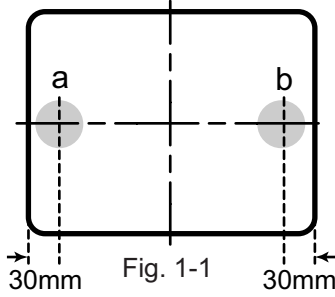
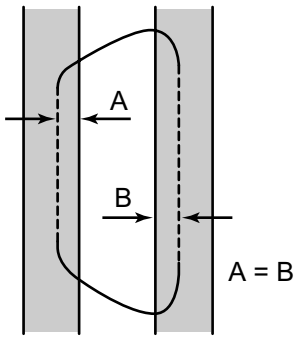
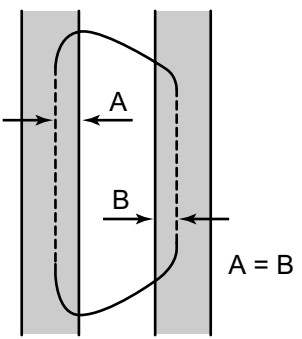
No.	Adjustment point	Adjustment procedure/conditions	Waveform and others
1	<p>PURITY ADJ.</p>	<ol style="list-style-type: none"> 1. Receive the GREEN-ONLY signal. Adjust the beam current to $\sim 700 \mu\text{A}$. 2. Degauss the CRT enough with the degaussing coil. Note: Follow the Job Instruction Sheet to adjust the magnetic field. Vertical Bv: $+0.045 \text{ mT}$ (0.45 gauss) Horizontal Bh: $+0.020 \text{ mT}$ (0.20 gauss) (Reference: page 3-6) 3. Maintain the purity magnet at the zero magnetic field and keep the static convergence roughly adjusted. 4. Observe the points a, b, as shown in Fig. 1-1 through the microscope. Adjust the landings to A rank requirement. 5. Orient the raster rotation to 0 eastward. 6. Tighten up the deflection coil screws. • Tightening torque: $108 \pm 20 \text{ N}$ ($11 \pm 2 \text{ kgf}$) 7. Make sure the CRT corners landing meet the A rank requirements. If not, stick the magnet sheet to correct it. <p>Note: This adjustment must be done after warming up the unit for 30 minutes or longer with a beam current over $700 \mu\text{A}$.</p> <p>Note: Set to service mode by remote controller then press factory process R/C RGB key to change to RGB mono colour mode.</p> <p>* For the following colours press R/C RGB(Hex 7E) key to change.</p> <pre> graph LR GREEN[GREEN ONLY] --> BLUE[BLUE ONLY] BLUE --> RED[RED ONLY] RED --> Screen[Signal-colour screen cleared] Screen --> GREEN </pre>	 <p>Fig. 1-1</p>  <p>Fig. 1-2 Rank "A" (on the right of the CRT)</p>  <p>Fig. 1-3 Rank "A" (on the left of the CRT)</p> <p>* Press R/C RGB key for 1 second in NORMAL MODE, the colour will change to RGB mono colour mode.</p>

3. CONVERGENCE ADJUSTMENT

No.	Adjustment point	Adjustment procedure/conditions	Waveform and others
1	<p>CONVERGENCE ADJ. (To be done after the purity adjustment.)</p>	<p>1. Receive the "Crosshatch Pattern" signal. 2. Using the remote controller, call NORMAL mode.</p> <p>Static convergence</p> <p>1. Turn the 4-pole magnet to a proper opening angle in order to superpose the blue and red colours. 2. Turn the 6-pole magnet to a proper opening angle in order to superpose the green colour over the blue and red colours.</p> <p>Dynamic convergence</p> <p>1. Adjust the convergence on the fringes of the screen in the following steps. a) Fig. a: Drive the wedge at point "a" and swing the deflection coil upward. b) Fig. b: Drive the wedge at point "b" and "c" and swing the deflection coil downward. c) Fig. c: Drive the "c" wedge deeper and swing the deflection coil rightward. d) Fig. d: Drive the "b" wedge deeper and swing the deflection coil leftward.</p> <p>2. Fix all the wedges on the CRT and apply glass tape over them. 3. Apply lacquer to the deflection yoke lock screw, magnet unit (purity, 4-pole, 6-pole magnets) and magnet unit lock screw.</p> <p>Finally received the Red-only and Blue-only signals to make sure there is no other colours on the screen.</p> <div data-bbox="600 1234 998 1543" data-label="Diagram"> </div> <div data-bbox="1120 1213 1518 1512" data-label="Diagram"> </div>	<div data-bbox="1193 241 1469 430" data-label="Figure"> <p>Fig. a</p> </div> <div data-bbox="1193 483 1469 672" data-label="Figure"> <p>Fig. b</p> </div> <div data-bbox="1161 724 1445 913" data-label="Figure"> <p>Fig. c</p> </div> <div data-bbox="1161 955 1445 1144" data-label="Figure"> <p>Fig. d</p> </div>

4. H-VCO, VIF-VCO & S-TRAP fo ADJUSTMENT

No.	Adjustment point	Adjustment procedure/conditions	Waveform and others
1	H-VCO ADJ (I ² C BUS CONTROL) (AUTO & MANUAL ADJ)	(MANUAL ADJ) 1) In No signal (RASTER) condition. 2) Go to service mode, choose service data V03 . 3) Connect oscilloscope to IC801 pin11 , adj V03 until freq become 15.625 ± 0.15 KHz (Auto Adj) 1) In No signal (RASTER) condition. 2) Go to service mode. 3) Choose service data V03 , by pressing R/C Auto (Hex C1) key, OSD will appear "OK" at screen. 4) If appear "NG" pls repeat step 3.	
2	VIF-VCO ADJ (I ² C BUS CONTROL) (AUTO & MANUAL ADJ)	(Manual ADJ) 1) In No signal (RASTER) condition. 2) Go to service mode, choose service data V02 . 3) Connect oscilloscope to IC801 pin2 , adj V02 until voltage become 2.5 ± 1 V . (Auto Adj) 1) In No signal (RASTER) condition. 2) Go to service mode, choose service data V02 . 3) Press the R/C Auto (Hex C1) key, OSD will appear "OK" at screen. 4) If appear "NG" pls repeat step 3.	This adjustment must be done after aging at least 3 minutes.
3	S-TRAP fo ADJ (I ² C BUS CONTROL) (AUTO & MANUAL ADJ)	(Manual ADJ) 1) In No signal (RASTER) condition. 2) Go to service mode, choose service data V21 . 3) Connect oscilloscope to TP 801 , adj V21 until voltage become Min (below 5 V). 4) After that pls adj service data V20 & V24 same as "V21" , V22 to "V21-1" , V23 to "V21+2" . (Auto Adj) 1) In No signal (RASTER) condition. 2) Go to service mode, choose service data V21 . 3) Press the R/C Auto (Hex C1) key, OSD will appear "OK" at screen. 4) If appear "NG" pls repeat step 3.	

5. SCREEN, WHITE BALANCE, SUB-BRIGHTNESS & SUB-CONTRAST ADJUSTMENT

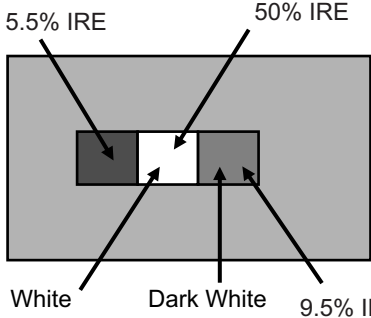
No.	Adjustment point	Adjustment procedure/conditions	Waveform and others																				
1	SCREEN ADJUSTMENT (I²C BUS CONTROL)	<p>1) In window pattern signal condition.</p> <p>2) Go to service mode, then select V00.</p> <p>3) By pressing R/C key S-Mute (Hex E8), R-D auto switch to 63, B-D auto switch to 63, R-C auto switch to 127, G-C auto switch to 127, B-C auto switch to 127, Sub-brightness V06 auto switch to 127. Y-mute & Vertical off, screen will be in vertical cut-off condition.</p> <p>4) Adjust the Screen so that cut-off line appear in low bright, then judge that whether the cut-off line appear in Red or Green or Blue color, in this condition between R-C & G-C & B-C, fix the data of the color appear in cut-off line and adj the other two cut-off data (Note 1) so that cut-off line color become white.</p> <p>5) Turn the screen VR of FBT so that cut-off line just disappear and use R/C by pressing key S-Mute (Hex E8) to disable the Y-mute & V-cut so that picture appear in normal mode.</p>	<table border="0"> <tr> <td>R-CUTOFF (R-C) UP</td> <td>RC key "1" (HEX 80)</td> </tr> <tr> <td>R-CUTOFF (R-C) DOWN</td> <td>RC key "4" (HEX 20)</td> </tr> <tr> <td>G-CUTOFF (G-C) UP</td> <td>RC key "2" (HEX 40)</td> </tr> <tr> <td>G-CUTOFF (G-C) DOWN</td> <td>RC key "5" (HEX A0)</td> </tr> <tr> <td>B-CUTOFF (B-C) UP</td> <td>RC key "3" (HEX C0)</td> </tr> <tr> <td>B-CUTOFF (B-C) DOWN</td> <td>RC key "6" (HEX 60)</td> </tr> <tr> <td>R-DRIVE (R-D) UP</td> <td>RC key "7" (HEX E0)</td> </tr> <tr> <td>R-DRIVE (R-D) DOWN</td> <td>RC key "Flashback" (HEX E4)</td> </tr> <tr> <td>B-DRIVE (B-D) UP</td> <td>RC key "8" (HEX 10)</td> </tr> <tr> <td>B-DRIVE (B-D) DOWN</td> <td>RC key "0" (HEX 50)</td> </tr> </table>	R-CUTOFF (R-C) UP	RC key "1" (HEX 80)	R-CUTOFF (R-C) DOWN	RC key "4" (HEX 20)	G-CUTOFF (G-C) UP	RC key "2" (HEX 40)	G-CUTOFF (G-C) DOWN	RC key "5" (HEX A0)	B-CUTOFF (B-C) UP	RC key "3" (HEX C0)	B-CUTOFF (B-C) DOWN	RC key "6" (HEX 60)	R-DRIVE (R-D) UP	RC key "7" (HEX E0)	R-DRIVE (R-D) DOWN	RC key "Flashback" (HEX E4)	B-DRIVE (B-D) UP	RC key "8" (HEX 10)	B-DRIVE (B-D) DOWN	RC key "0" (HEX 50)
R-CUTOFF (R-C) UP	RC key "1" (HEX 80)																						
R-CUTOFF (R-C) DOWN	RC key "4" (HEX 20)																						
G-CUTOFF (G-C) UP	RC key "2" (HEX 40)																						
G-CUTOFF (G-C) DOWN	RC key "5" (HEX A0)																						
B-CUTOFF (B-C) UP	RC key "3" (HEX C0)																						
B-CUTOFF (B-C) DOWN	RC key "6" (HEX 60)																						
R-DRIVE (R-D) UP	RC key "7" (HEX E0)																						
R-DRIVE (R-D) DOWN	RC key "Flashback" (HEX E4)																						
B-DRIVE (B-D) UP	RC key "8" (HEX 10)																						
B-DRIVE (B-D) DOWN	RC key "0" (HEX 50)																						
2	WHITE BALANCE ADJ (to be done after screen adj) (I²C BUS CONTROL)	<p>1) WHITE (HIGH BEAM) (In Window Pattern Signal) First use Minolta Color Analyzer CA100, let the gun point at Dark White position (as drawing attach), Adj V06 until LUMINANCE Y become 5 cd/m², then let the gun point at White position (as drawing attach), Adj V04 until LUMINANCE Y become: 160 cd/m². Adj the R-D & B-D until the axis of color temperature become X=0.30, Y=0.31 7500°K</p> <p>2) DARK WHITE (LOW BEAM) (In Window Pattern Signal) Let the gun point at Dark White position, if the color temperature data shift away from the data adjusted in step 1, adjust R-C, G-C & B-C but between them, first color appears in Screen adj item 1)-4 is fixed, adj the other two so that to obtain the similar axis as above. ** Repeat step 1 & 2 to get a regulated position.</p>	<p style="text-align: center;">WINDOW PATTERN SIGNAL</p>  <p style="text-align: center;">*Note : Signal using W/B Pattern Generator SX-1006 (IWATSU) or equivalent. Window Pattern Signal output level are as above:</p>																				

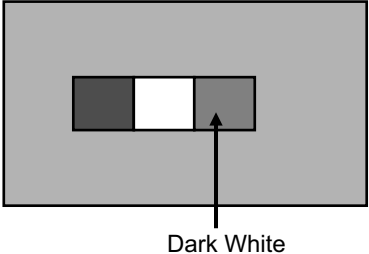
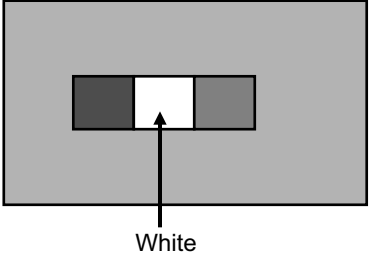
No.	Adjustment point	Adjustment procedure/conditions	Waveform and others
3	SUB-BRIGHTNESS (to be done after screen, white balance adj) (I ² C BUS CONTROL)	1) In Window Pattern Signal condition. 2) Using Minolta Color Analyzer CA-100, let the gun point at Dark White position (as attach drawing), adjust V06 Bus data until LUMINANCE Y = 3 ± 0.5 cd/m² .	WINDOW PATTERN SIGNAL 
4	SUB-CONTRAST (to be done after screen, white balance adj, sub-brightness adj) (I ² C BUS CONTROL)	1) In Window Pattern Signal condition. 2) Using Minolta Color Analyzer CA-100, let the gun point at White position (as attach drawing), adjust V04 Bus data until LUMINANCE Y = 160 ± 10cd/m²	WINDOW PATTERN SIGNAL 
5	Beam Current Check	1) Receive the "Monoscope Pattern" signal. 2) Press R/C to set Picture NORMAL condition. 3) Connect the DC miliammeter between TP 603 (+) & TP 602 (-). (Full Scale: 3mA Range) 4) Beam current must be within 1000 ± 100 μA .	

6. HORIZONTAL, VERTICAL, DEFLECTION LOOP and FOCUS ADJUSTMENT

No.	Adjustment point	Adjustment procedure/conditions	Waveform and others
1	H-SHIFT (I ² C BUS CONTROL) (to be done after purity adj)	1) Receive Monoscope Pattern Signal (PAL 50 Hz) 2) Choose the service data V13 . 3) Adjust the V13 bus data to have a balance position to spec of A=B (as attach drawing) 4) If cannot make it to A=B , adjust from the best point so that B slightly smaller than A .	
2	V-SHIFT (I ² C BUS CONTROL) (to be done after purity adj)	1) Receive Monoscope Pattern Signal (PAL 50 Hz) 2) Choose the service data V12 . 3) Adjust V12 bus data to have a most acceptable vertical position, the monoscope pattern should be Balance in vertical position. Note: B line (Monoscope middle line) must same or nearest higher position to the A mark (Tube middle mark), refer to the attach drawing.	Figure:
3	V-SIZE (I ² C BUS CONTROL) (to be done after purity, V-shift adj)	1) Receive Monoscope Pattern Signal (PAL 50 Hz) 2) Choose the service data V11 . 3) Adjust V11 bus data until the overscan become 10 ± 1.5 % Caution1: Pls aging TV more than 10 minutes before adjustment. Caution2: for H-shift & V-shift & V-size adj, after adj pls switch to Monoscope pattern signal (NTSC 60 Hz) to confirm all position are the same.	
4	SUB-SHARPNESS	1) Confirm Service data V08 is 46 .	
5	Focus	1) Receive the "Monoscope Pattern" signal. 2) Press R/C to set Picture NORMAL condition. 3) Adjust the focus control to get the best focusing.	

7. PAL CHROMA ADJUSTMENT

No.	Adjustment point	Adjustment procedure/conditions	Waveform and others
1	SUB COLOUR (I ² C BUS CONTROL) (to be done after sub-picture, sub-tint adj)	1) Receive the "PAL Colour Bar" signal. 2) Press R/C to set Picture Normal condition. 3) Connect the oscilloscope to R-Amp Transistor Base(TP 851). Range : 100mV/Div (AC) (Using 10:1 Probe) Sweep Time : 10 μ sec/Div 4) Using the R/C call V05 in SERVICE mode. Adjust V05 bus data, so that the 75% White & Red portions of PAL Colour Bar be at the same level shown as Fig 1-1. 5) Clear the SERVICE mode.	<p>Fig. 1-1</p>

8. NTSC CHROMA ADJUSTMET

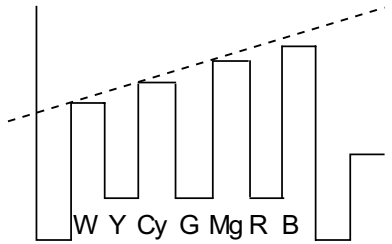
No.	Adjustment point	Adjustment procedure/conditions	Waveform and others
1	<p>SUB-TINT (I²C BUS CONTROL)</p>	<ol style="list-style-type: none"> 1) Receive the "NTSC3.58 Colour Bar" signal thru AV in. 2) Connect the oscilloscope to B-Amp Transistor Base (TP853). <ul style="list-style-type: none"> ● Range : 100mV/Div. (AC)(Use Probe 10:1) ● Sweep time : 10 μsec/Div. 3) In Service mode, go to V07, press R/C Y-mute(Hex E4) or FLASHBACK Key. 4) Call the "V07" data in service mode. Adjust the "V07" bus data to obtain the waveform shown as Fig. 1-1. 5) Disable Y-Mute by pressing key(Hex E4) or FLASHBACK, then clear the SERVICE mode. 	 <p style="text-align: center;">Fig. 1-1</p>

9. SECAM CHROMA ADJUSTMENT

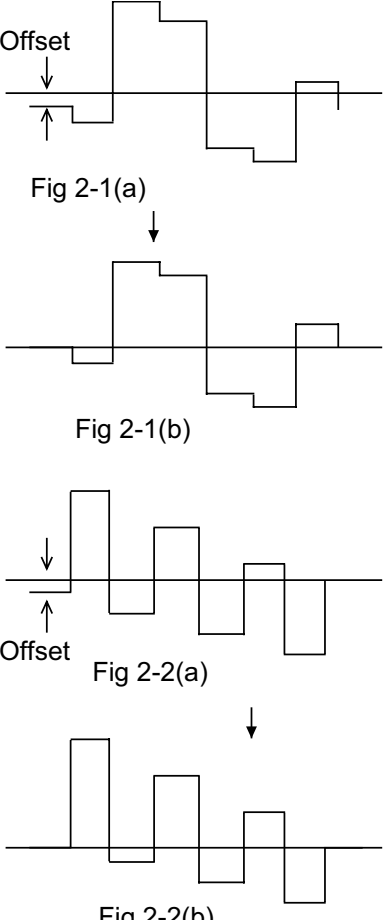
No.	Adjustment point	Adjustment procedure/conditions	Waveform and others
1	<p>SECAM BLACK LEVEL R-Y/B-Y (I²C BUS CONTROL)</p>	<ol style="list-style-type: none"> 1) Receive "SECAM COLOUR BAR" signal. 2) In the service mode, select service data V14. 3) Connect oscilloscope to TP 801. <ul style="list-style-type: none"> ● Range : 20mV/Div. (AC)(Use Probe 10:1) ● Sweep time : 20 μsec/Div. 4) Adjust the V14 so that the offset of R-Y is minimum, shown in Fig 2-1(b), it means adjust the offset of between No signal line and Signal line to minimum. 5) In the service mode, select service data V15. 6) Connect oscilloscope to TP 801. <ul style="list-style-type: none"> ● Range : 20mV/Div. (AC)(Use Probe 10:1) ● Sweep time : 20 μsec/Div. 7) Adjust the V15 so that the offset of B-Y to minimum, shown in Fig 2-2(b), it means adjust the offset of between No signal line and Signal line to minimum. 	 <p style="text-align: center;">Fig 2-1(a)</p> <p style="text-align: center;">Fig 2-1(b)</p> <p style="text-align: center;">Fig 2-2(a)</p> <p style="text-align: center;">Fig 2-2(b)</p>

10. PROTECTOR OPERATION CHECKING

No.	Adjustment point	Adjustment procedure/conditions	Waveform and others
1	BEAM PROTECTOR	1) Receive "Monoscope Pattern" signal. 2) Set CONTRAST MAX. 3) Set BRIGHT MAX. 4) During the Collector & Emitter of Q853/4/5 short, make sure the protector ON and switch to standby mode.	* Select one of Q853/4/5 to do each short.
2	H, V PROTECTOR	1) Receive "Monoscope Pattern" signal. 2) Connect output of Bias Box to D602 cathode (C602 positive). 3) Set voltage of Bias Box to 18V and make sure the protector is not working. 4) Set voltage of Bias Box to 27V , and make sure the protector is working.	
3	OTHER PROTECTOR	1) Once finish rectified Electrolytic Capacitor short testing in +B line, check all possible damaged components on +B line. (Use random selected set for inspection)	

11. A/V INPUT, OUTPUT & COMPONENT IN CHECKING

No.	Adjustment point	Adjustment procedure/conditions	Waveform and others
1	VIDEO AND AUDIO OUTPUT CHECK	1) Receive the "PAL Color Bar" signal (100% White Color Bar, Sound 400 Hz 100% Mod). 2) Terminate the Video output with a 75 ohm impedance. Make sure the output is as specified (1.0 Vp-p ± 3 dB) . 3) Terminate the Audio output with a 10K ohm impedance. Make sure the O/P is as specified (1.5 Vp-p ± 3 dB) .	
2	VIDEO AND AUDIO INPUT CHECK	1) Using the TV/VIDEO key on the remote controller, make sure that the modes change in order of TV, AV1, AV2 & TV again and the video & audio output are according to the input terminal for each mode.	
3	COMPONENT IN CHECK	1) Connect YUV & Audio signal to Component In terminal and Audio terminal. 2) Using the TV/VIDEO key on the remote controller, press it until the modes change to COMPONENT, confirm output is appear.	

12. FUNCTION OPERATION CHECKING (VIDEO AND AUDIO)

No.	Adjustment point	Adjustment procedure/conditions	Waveform and others
1	CONTRAST key	1) Receive "Monoscope Pattern" signal. 2) Set MENU, then go into PICTURE mode to select CONTRAST. 3) Press Volume Up/Down key to check whether the CONTRAST effect is OK or not.	
2	COLOUR key	1) Receive "Colour Bar" signal. 2) Set MENU, then go into PICTURE mode to select COLOUR. 3) Press Volume Up/Down key to check whether the COLOUR effect is OK or not.	
3	BRIGHTNESS key	1) Receive "Monoscope Pattern" signal. 2) Set MENU, then go into PICTURE mode to select BRIGHTNESS. 3) Press Volume Up/Down key to check whether the BRIGHTNESS effect is OK or not.	
4	TINT key	1) Receive the "NTSC Colour Bar" signal thru AV in. 2) Set MENU, then go into PICTURE mode to select TINT. 3) Press Volume Up/Down key to check TINT, UP for GREEN direction and DOWN for PURPLE direction whether is OK or not.	
5	SHARPNESS Key	1) Receive "Monoscope Pattern" signal. 2) Set MENU, then go into PICTURE mode to select SHARPNESS. 3) Press Volume Up/Down key to check whether the SHARPNESS effect is OK or not.	
6	CH DISPLAY COLOUR	1) All Ch (1~99) will have an OSD display of the channel number in green colour under AFT ON condition.	
7	NORMAL Key	1) Once in PICTURE or SOUND Mode, and the NORMAL key is pressed, all the settings will be preset to normal setting accordingly. (Normal setting value for every mode) PICTURE MODE *SOUND MODE CONTRAST : MAX SURROUND : OFF COLOUR : CENTER TREBLE : CENTER BRIGHTNESS : CENTER BASS : CENTER TINT : CENTER BALANCE : CENTER SHARPNESS : CENTER WHITE TEMP : CENTER	In NORMAL Mode, when press NORMAL key, will appear NORMAL OSD and all setting PICTURE, SOUND functions set to NORMAL.
8	WHITE TEMP	1) Receive "Monoscope Pattern" signal. 2) Set MENU, then go into PICTURE mode to select WHITE TEMP. 3) Press Volume Up/Down key to check WHITE TEMP function The back ground will change to (shift right) bluish and (shift left) reddish.	

No.	Adjustment point	Adjustment procedure/conditions	Waveform and others
9	COLOUR SYSTEM	1)Receive the "PAL COLOUR BAR" signal, press MENU, choose CH-SETTING to select COLOR modes except PAL, check the COLOUR is not working properly. Then, select the "PAL" mode. Check again its colour so that it is working properly. 2)Receive "SECAM COLOUR BAR" signal, press MENU, choose CH-SETTING to select COLOR modes except SECAM, check the COLOUR is not working properly. Then, select the "SECAM" mode. Check again its colour so that it is working properly. 3)Receive "NTSC 4.43" signal, press MENU, choose CH-SETTING to select COLOR modes except N443, check the COLOUR is not working properly. Then, select the N443 mode. Check again its colour so that it is working properly. 4)Receive "NTSC 3.58" signal thru AV, press MENU, choose CH-SETTING to select COLOR modes except N358, check the COLOUR is not working properly. Then, select the N358 mode. Check again its colour so that it is working properly.	
10	SURROUND	1)Receive "music" sound signal. 2)Set MENU, then go into SOUND MENU to select SURROUND. 3)Press VOLUME UP/DOWN key to check SURROUND I, II and OFF effect.	
11	TREBLE	1)Receive "music" sound signal. 2)Set MENU, then go into SOUND MENU to select TREBLE. 3)Press VOLUME UP/DOWN key to check whether the TREBLE effect is OK or not.	
12	BASS	1)Receive "music" sound signal. 2)Set MENU, then go into SOUND MENU to select BASS. 3)Press VOLUME UP/DOWN key to check whether the BASS effect is OK or not.	
13	BALANCE	1)Receive mono-tone signal. 2)Set MENU, then go into SOUND MENU to select BALANCE. 3)Press VOLUME UP/DOWN key to check whether the left to right BALANCE effect is OK or not.	
14	NOISE MUTE CHECKING	1)Receive "PAL COLOUR BAR" signal. 2)Turn up the volume control to maximum, make sure the sound is heard from the speakers. Then put the unit in no signal state. 3)Check the sound mute is effective. 4)Finally turn sound level of CTV to minimum.	

No.	Adjustment point	Adjustment procedure/conditions	Waveform and others																
15	SOUND SYSTEM	<p>1)Receive "PAL-D/K" signal, press MENU, choose CH-SETTING then go into SOUND mode to select B/G, I, M. Check the sound output is not working properly. Select D/K and check the sound output to make sure it is working properly.</p> <p>2)Receive "PAL-I" signal, press MENU, choose CH-SETTING then go into SOUND mode to select B/G, D/K, M. Check the sound output is not working properly. Select I and check the sound output to make sure it is working properly.</p> <p>3)Receive "PAL-B/G" signal, press MENU, choose CH-SETTING then go into SOUND mode to select I, D/K, M. Check the sound output is not working properly. Select B/G and check the sound output to make sure it is working properly.</p>																	
16	OSD LANGUAGE QUANTITY CHECK	<p>1)Check OSD LANGUAGE quantity and type for respect model.</p> <table border="1"> <thead> <tr> <th>MODEL</th> <th>QUANTITY</th> <th>ENGLISH</th> <th>RUSSIAN</th> <th>CHINESE</th> <th>FRENCH</th> <th>ARABIC</th> <th>MALAY</th> </tr> </thead> <tbody> <tr> <td>21J-FG1RU</td> <td>2</td> <td>0</td> <td>0</td> <td>-</td> <td>-</td> <td>-</td> <td>-</td> </tr> </tbody> </table>	MODEL	QUANTITY	ENGLISH	RUSSIAN	CHINESE	FRENCH	ARABIC	MALAY	21J-FG1RU	2	0	0	-	-	-	-	
MODEL	QUANTITY	ENGLISH	RUSSIAN	CHINESE	FRENCH	ARABIC	MALAY												
21J-FG1RU	2	0	0	-	-	-	-												

13. HEADPHONE JACK CHECKING

No.	Adjustment point	Adjustment procedure/conditions	Waveform and others
1	HEADPHONE OUTPUT CHECKING	<p>1) Receive PAL COLOUR BAR with SOUND 400Hz, 100% MODULATION (± 50kHz Dev).</p> <p>2) Maximum volume, and check the headphone output with 400Hz sound and no sound output from speaker.</p>	

14. SHOCK TEST CHECKING

No.	Adjustment point	Adjustment procedure/conditions	Waveform and others
1	SHOCK TEST	<p>1) Hit at the top of TV set for two time.</p> <p>2) Check TV set not damage and TV operation operate correctly.</p>	

15. ROM CORRECTION CHECKING

No.	Adjustment point	Adjustment procedure/conditions	Waveform and others																															
1	ROM CORRECTION CHECK	<p>1) Go to SERVICE mode, press "MENU" key until the SERVICE mode display as in Figure 1 appeared.*</p> <p>2) Check the ROM CORRECTION status by monitoring the screen, follow the model's setting.</p> <table border="1"> <thead> <tr> <th>MODEL</th> <th>Micon Version</th> <th>CHK1</th> <th>CHK2</th> <th>FIGURE</th> </tr> </thead> <tbody> <tr> <td>21J-FG1RU</td> <td>RH-IXB226WJZZ(Software Ver. 1.0)</td> <td>ACT</td> <td>NO</td> <td></td> </tr> </tbody> </table> <p>CHK1: AC-DET protection loop is to be exited when AD3 (Prot) is detected HIGH so that protection mode can perform properly</p>	MODEL	Micon Version	CHK1	CHK2	FIGURE	21J-FG1RU	RH-IXB226WJZZ(Software Ver. 1.0)	ACT	NO		<p>* OTHERS:</p> <table border="1"> <thead> <tr> <th colspan="3">INFO</th> </tr> </thead> <tbody> <tr> <td>SLV1</td> <td>0</td> <td>0</td> </tr> <tr> <td>SLV2</td> <td>0</td> <td>0</td> </tr> <tr> <td>SLV4</td> <td>0</td> <td>0</td> </tr> <tr> <td>SLV7</td> <td>0</td> <td>0</td> </tr> <tr> <td>MICON: ZZ</td> <td>CHK1: ACT</td> <td></td> </tr> <tr> <td>SOFT : 1.0</td> <td>CHK2: NO</td> <td></td> </tr> </tbody> </table> <p>Figure 1</p>	INFO			SLV1	0	0	SLV2	0	0	SLV4	0	0	SLV7	0	0	MICON: ZZ	CHK1: ACT		SOFT : 1.0	CHK2: NO	
MODEL	Micon Version	CHK1	CHK2	FIGURE																														
21J-FG1RU	RH-IXB226WJZZ(Software Ver. 1.0)	ACT	NO																															
INFO																																		
SLV1	0	0																																
SLV2	0	0																																
SLV4	0	0																																
SLV7	0	0																																
MICON: ZZ	CHK1: ACT																																	
SOFT : 1.0	CHK2: NO																																	

ROM CORRECTION DATA

MCU:	M37160MAH-052FP									
Soft Ver.	V1.00H									
ROMCORRECT1...	AC-DET protection loop is to be exited when AD3(Prot) is detected HIGH so that protection mode can perform properly									
ROMCORRECT2...										
EEPROM Data										
Slave	Sub.	Data								Comment
\$A2	\$76	A0								ROMCORRECT1 Permission
\$A2	\$77	92								ROMCORRECT1 Address(H)
\$A2	\$78	14								ROMCORRECT1 Address(L)
\$A2	\$79	0F								ROMCORRECT1 Code length
\$A2	\$7A	07								ROMCORRECT1 Checksum
\$A2	\$7B	FF								ROMCORRECT2 Permission
\$A2	\$7C	FF								ROMCORRECT2 Address(H)
\$A2	\$7D	FF								ROMCORRECT2 Address(L)
\$A2	\$7E	FF								ROMCORRECT2 Code length
\$A2	\$7F	FF								ROMCORRECT2 Checksum
\$A2	\$80-87	A2	40	A9	02	20	D2	F3	90	ROMCORRECT1 Data
\$A2	\$88-\$8F	03	4C	CD	91	4C	17	92	FF	ROMCORRECT1 Data
\$A2	\$90-\$97	FF	FF	FF	FF	FF	FF	FF	FF	ROMCORRECT1 Data
\$A2	\$98-\$9F	FF	FF	FF	FF	FF	FF	FF	FF	ROMCORRECT1 Data
\$A2	\$A0-\$A7	FF	FF	FF	FF	FF	FF	FF	FF	ROMCORRECT2 Data
\$A2	\$A8-\$AF	FF	FF	FF	FF	FF	FF	FF	FF	ROMCORRECT2 Data
\$A2	\$B0-\$B7	FF	FF	FF	FF	FF	FF	FF	FF	ROMCORRECT2 Data
\$A2	\$B8-\$BF	FF	FF	FF	FF	FF	FF	FF	FF	ROMCORRECT2 Data

NOTE: Add ROM Correction for countermeasure for data change when AGING and AC POWER OFF. There is possibility of changing background color if no implement ROM Correction when AGING and AC power OFF.

CHAPTER 4. MEMORY MAP

[1] MEMORY MAP

SLAVE ADDRESS : A0(00-FF) A2(100-1FF) A4(200-2FF) A6(300-3FF) A8(400-4FF)

ADDRESS (HEX)	DATA							MICON DEFAULT	EEPROM RANGE	EEPROM WRITE(CPU)	CHASSIS		CTV FINAL		LAST INITIAL SETTING DATA	REMARK		
	D7	D6	D5	D4	D3	D2	D1				D0	CHECK DATA	CHECK TYPE	CHECK DATA			CHECK TYPE	
00	EEPROM INITIALIZATION JUDGEMENT BYTE-0							7B	00-FF									
01	EEPROM INITIALIZATION JUDGEMENT BYTE-1							72	00-FF									
02	EEPROM INITIALIZATION JUDGEMENT BYTE-2							72	00-FF								* depend on hcode, current this model is XB226 so set as 7B 72 72 76.	
03	EEPROM INITIALIZATION JUDGEMENT BYTE-3							76	00-FF									
04	ROM VERSION							00	00-FF									
05	SOFTWARE VERSION (HIGH BYTE)							00	00-FF									
06	SOFTWARE VERSION (LOW BYTE)							46	00-FF								*depend on final release version. If version 0.70 so it will become 00 & 46	
07																		
08	TUNING FREQUENCY (LOW BYTE)								00-FF									
09	TUNING FREQUENCY (HIGH BYTE)								00-FF								POS 0	
0A	TUNING FREQUENCY (LOW BYTE)								00-FF								POS 1	
0B	TUNING FREQUENCY (HIGH BYTE)								00-FF								POS 2	
0C	TUNING FREQUENCY (LOW BYTE)								00-FF								POS 3	
0D	TUNING FREQUENCY (HIGH BYTE)								00-FF								POS 4	
0E	TUNING FREQUENCY (LOW BYTE)								00-FF								POS 5	
0F	TUNING FREQUENCY (HIGH BYTE)								00-FF								POS 6	
10	TUNING FREQUENCY (LOW BYTE)								00-FF								POS 7	
11	TUNING FREQUENCY (HIGH BYTE)								00-FF								POS 8	
12	TUNING FREQUENCY (LOW BYTE)								00-FF								POS 9	
13	TUNING FREQUENCY (HIGH BYTE)								00-FF								POS 10	
14	TUNING FREQUENCY (LOW BYTE)								00-FF								POS 11	
15	TUNING FREQUENCY (HIGH BYTE)								00-FF								POS 12	
16	TUNING FREQUENCY (LOW BYTE)								00-FF								POS 13	
17	TUNING FREQUENCY (HIGH BYTE)								00-FF								POS 14	
18	TUNING FREQUENCY (LOW BYTE)								00-FF								POS 15	
19	TUNING FREQUENCY (HIGH BYTE)								00-FF								POS 16	
1A	TUNING FREQUENCY (LOW BYTE)								00-FF								POS 17	
1B	TUNING FREQUENCY (HIGH BYTE)								00-FF								POS 18	
1C	TUNING FREQUENCY (LOW BYTE)								00-FF								POS 19	
1D	TUNING FREQUENCY (HIGH BYTE)								00-FF								POS 20	
1E	TUNING FREQUENCY (LOW BYTE)								00-FF								POS 21	
1F	TUNING FREQUENCY (HIGH BYTE)								00-FF								POS 22	
20	TUNING FREQUENCY (LOW BYTE)								00-FF								POS 23	
21	TUNING FREQUENCY (HIGH BYTE)								00-FF								POS 24	
22	TUNING FREQUENCY (LOW BYTE)								00-FF								POS 25	
23	TUNING FREQUENCY (HIGH BYTE)								00-FF								POS 26	
24	TUNING FREQUENCY (LOW BYTE)								00-FF								POS 27	
25	TUNING FREQUENCY (HIGH BYTE)								00-FF									
26	TUNING FREQUENCY (LOW BYTE)								00-FF									
27	TUNING FREQUENCY (HIGH BYTE)								00-FF									
28	TUNING FREQUENCY (LOW BYTE)								00-FF									
29	TUNING FREQUENCY (HIGH BYTE)								00-FF									
2A	TUNING FREQUENCY (LOW BYTE)								00-FF									
2B	TUNING FREQUENCY (HIGH BYTE)								00-FF									
2C	TUNING FREQUENCY (LOW BYTE)								00-FF									
2D	TUNING FREQUENCY (HIGH BYTE)								00-FF									
2E	TUNING FREQUENCY (LOW BYTE)								00-FF									
2F	TUNING FREQUENCY (HIGH BYTE)								00-FF									
30	TUNING FREQUENCY (LOW BYTE)								00-FF									
31	TUNING FREQUENCY (HIGH BYTE)								00-FF									
32	TUNING FREQUENCY (LOW BYTE)								00-FF									
33	TUNING FREQUENCY (HIGH BYTE)								00-FF									
34	TUNING FREQUENCY (LOW BYTE)								00-FF									
35	TUNING FREQUENCY (HIGH BYTE)								00-FF									
36	TUNING FREQUENCY (LOW BYTE)								00-FF									
37	TUNING FREQUENCY (HIGH BYTE)								00-FF									
38	TUNING FREQUENCY (LOW BYTE)								00-FF									
39	TUNING FREQUENCY (HIGH BYTE)								00-FF									
3A	TUNING FREQUENCY (LOW BYTE)								00-FF									
3B	TUNING FREQUENCY (HIGH BYTE)								00-FF									
3C	TUNING FREQUENCY (LOW BYTE)								00-FF									
3D	TUNING FREQUENCY (HIGH BYTE)								00-FF									
3E	TUNING FREQUENCY (LOW BYTE)								00-FF									
3F	TUNING FREQUENCY (HIGH BYTE)								00-FF									
MODEL								MODEL										
LETTER NO.								LETTER NO.										

21J-FG1RU

MEMORY MAP (Continued)

SLAVE ADDRESS : A0(00-FF) A2(100-1FF) A4(200-2FF) A6(300-3FF) A8(400-4FF)

ADDRESS (HEX)	DATA								MICON DEFAULT	EEPROM RANGE	EEPROM WRITE(CPU)	CHASSIS		CTV FINAL		LAST INITIAL SETTING DATA	REMARK				
	D7	D6	D5	D4	D3	D2	D1	D0				CHECK DATA	CHECK TYPE	CHECK DATA	CHECK TYPE						
80	TUNING FREQUENCY (LOW BYTE)									00-FF								POS 60			
81	TUNING FREQUENCY (HIGH BYTE)									00-FF											
82	TUNING FREQUENCY (LOW BYTE)									00-FF									POS 61		
83	TUNING FREQUENCY (HIGH BYTE)									00-FF											
84	TUNING FREQUENCY (LOW BYTE)									00-FF									POS 62		
85	TUNING FREQUENCY (HIGH BYTE)									00-FF											
86	TUNING FREQUENCY (LOW BYTE)									00-FF									POS 63		
87	TUNING FREQUENCY (HIGH BYTE)									00-FF											
88	TUNING FREQUENCY (LOW BYTE)									00-FF									POS 64		
89	TUNING FREQUENCY (HIGH BYTE)									00-FF											
8A	TUNING FREQUENCY (LOW BYTE)									00-FF									POS 65		
8B	TUNING FREQUENCY (HIGH BYTE)									00-FF											
8C	TUNING FREQUENCY (LOW BYTE)									00-FF									POS 66		
8D	TUNING FREQUENCY (HIGH BYTE)									00-FF											
8E	TUNING FREQUENCY (LOW BYTE)									00-FF									POS 67		
8F	TUNING FREQUENCY (HIGH BYTE)									00-FF											
90	TUNING FREQUENCY (LOW BYTE)									00-FF									POS 68		
91	TUNING FREQUENCY (HIGH BYTE)									00-FF											
92	TUNING FREQUENCY (LOW BYTE)									00-FF									POS 69		
93	TUNING FREQUENCY (HIGH BYTE)									00-FF											
94	TUNING FREQUENCY (LOW BYTE)									00-FF									POS 70		
95	TUNING FREQUENCY (HIGH BYTE)									00-FF											
96	TUNING FREQUENCY (LOW BYTE)									00-FF									POS 71		
97	TUNING FREQUENCY (HIGH BYTE)									00-FF											
98	TUNING FREQUENCY (LOW BYTE)									00-FF									POS 72		
99	TUNING FREQUENCY (HIGH BYTE)									00-FF											
9A	TUNING FREQUENCY (LOW BYTE)									00-FF									POS 73		
9B	TUNING FREQUENCY (HIGH BYTE)									00-FF											
9C	TUNING FREQUENCY (LOW BYTE)									00-FF									POS 74		
9D	TUNING FREQUENCY (HIGH BYTE)									00-FF											
9E	TUNING FREQUENCY (LOW BYTE)									00-FF									POS 75		
9F	TUNING FREQUENCY (HIGH BYTE)									00-FF											
A0	TUNING FREQUENCY (LOW BYTE)									00-FF									POS 76		
A1	TUNING FREQUENCY (HIGH BYTE)									00-FF											
A2	TUNING FREQUENCY (LOW BYTE)									00-FF									POS 77		
A3	TUNING FREQUENCY (HIGH BYTE)									00-FF											
A4	TUNING FREQUENCY (LOW BYTE)									00-FF									POS 78		
A5	TUNING FREQUENCY (HIGH BYTE)									00-FF											
A6	TUNING FREQUENCY (LOW BYTE)									00-FF									POS 79		
A7	TUNING FREQUENCY (HIGH BYTE)									00-FF											
A8	TUNING FREQUENCY (LOW BYTE)									00-FF									POS 80		
A9	TUNING FREQUENCY (HIGH BYTE)									00-FF											
AA	TUNING FREQUENCY (LOW BYTE)									00-FF									POS 81		
AB	TUNING FREQUENCY (HIGH BYTE)									00-FF											
AC	TUNING FREQUENCY (LOW BYTE)									00-FF									POS 82		
AD	TUNING FREQUENCY (HIGH BYTE)									00-FF											
AE	TUNING FREQUENCY (LOW BYTE)									00-FF									POS 83		
AF	TUNING FREQUENCY (HIGH BYTE)									00-FF											
B0	TUNING FREQUENCY (LOW BYTE)									00-FF									POS 84		
B1	TUNING FREQUENCY (HIGH BYTE)									00-FF											
B2	TUNING FREQUENCY (LOW BYTE)									00-FF									POS 85		
B3	TUNING FREQUENCY (HIGH BYTE)									00-FF											
B4	TUNING FREQUENCY (LOW BYTE)									00-FF									POS 86		
B5	TUNING FREQUENCY (HIGH BYTE)									00-FF											
B6	TUNING FREQUENCY (LOW BYTE)									00-FF									POS 87		
B7	TUNING FREQUENCY (HIGH BYTE)									00-FF											
B8	TUNING FREQUENCY (LOW BYTE)									00-FF									POS 88		
B9	TUNING FREQUENCY (HIGH BYTE)									00-FF											
BA	TUNING FREQUENCY (LOW BYTE)									00-FF									POS 89		
BB	TUNING FREQUENCY (HIGH BYTE)									00-FF											
BC	TUNING FREQUENCY (LOW BYTE)									00-FF									POS 90		
BD	TUNING FREQUENCY (HIGH BYTE)									00-FF											
BE	TUNING FREQUENCY (LOW BYTE)									00-FF									POS 91		
BF	TUNING FREQUENCY (HIGH BYTE)									00-FF											
MODEL									MODEL												
LETTER NO.									LETTER NO.												

MEMORY MAP (Continued)

SLAVE ADDRESS : A0(00-FF) A2(100-1FF) A4(200-2FF) A6(300-3FF) A8(400-4FF)

ADDRESS (HEX)	DATA								MICON DEFAULT	EEPROM RANGE	EEPROM WRITE(CPU)	CHASSIS		CTV FINAL		LAST INITIAL SETTING DATA	REMARK					
	D7	D6	D5	D4	D3	D2	D1	D0				CHECK DATA	CHECK TYPE	CHECK DATA	CHECK TYPE							
C0	TUNING FREQUENCY (LOW BYTE)									00-FF							POS 92					
C1	TUNING FREQUENCY (HIGH BYTE)									00-FF												
C2	TUNING FREQUENCY (LOW BYTE)									00-FF												
C3	TUNING FREQUENCY (HIGH BYTE)									00-FF							POS 93					
C4	TUNING FREQUENCY (LOW BYTE)									00-FF												
C5	TUNING FREQUENCY (HIGH BYTE)									00-FF							POS 94					
C6	TUNING FREQUENCY (LOW BYTE)									00-FF												
C7	TUNING FREQUENCY (HIGH BYTE)									00-FF												
C8	TUNING FREQUENCY (LOW BYTE)									00-FF							POS 96					
C9	TUNING FREQUENCY (HIGH BYTE)									00-FF												
CA	TUNING FREQUENCY (LOW BYTE)									00-FF												
CB	TUNING FREQUENCY (HIGH BYTE)									00-FF							POS 97					
CC	TUNING FREQUENCY (LOW BYTE)									00-FF												
CD	TUNING FREQUENCY (HIGH BYTE)									00-FF							POS 98					
CE	TUNING FREQUENCY (LOW BYTE)									00-FF												
CF	TUNING FREQUENCY (HIGH BYTE)									00-FF							POS 99					
D0	FAVORITE CHANNEL 1								0A	00-65							POS 10					
D1	FAVORITE CHANNEL 2								14	00-65							POS 20					
D2	FAVORITE CHANNEL 3								1E	00-65							POS 30					
D3	FAVORITE CHANNEL 4								28	00-65							POS 40					
D4	LAST CONTRAST								3C	00-3C												
D5	LAST COLOUR								1E	00-3C												
D6	LAST BRIGHTNESS								1E	00-3C												
D7	LAST TINT								1E	00-3C												
D8	LAST SHARPNESS								1E	00-3C												
D9	LAST WHITE TEMP.								01	00-02												
DA	LAST SURROUND MODE								00	00-02												
DB	LAST TREBLE								1E	00-3C												
DC	LAST BASS								1E	00-3C												
DD	LAST BALANCE								1E	00-3C												
DE						Message Screen	Message Display	S-Booster	01	00-01						(1) Add Message Display ON/OFF setting.						
DF																						
E0	POS 7	POS 6	POS 5	POS 4	POS 3	POS 2	POS 1	POS 0	FF	00-FF												
E1	POS15	POS14	POS13	POS12	POS11	POS10	POS 9	POS 8	FF	00-FF												
E2	POS23	POS22	POS21	POS20	POS19	POS18	POS17	POS16	FF	00-FF												
E3	POS31	POS30	POS29	POS28	POS27	POS26	POS25	POS24	FF	00-FF												
E4	POS39	POS38	POS37	POS36	POS35	POS34	POS33	POS32	FF	00-FF												
E5	POS47	POS46	POS45	POS44	POS43	POS42	POS41	POS40	FF	00-FF												
E6	POS55	POS54	POS53	POS52	POS51	POS50	POS49	POS48	FF	00-FF												
E7	POS63	POS62	POS61	POS60	POS59	POS58	POS57	POS56	FF	00-FF												
E8	POS71	POS70	POS69	POS68	POS67	POS66	POS65	POS64	FF	00-FF												
E9	POS79	POS78	POS77	POS76	POS75	POS74	POS73	POS72	FF	00-FF												
EA	POS87	POS86	POS85	POS84	POS83	POS82	POS81	POS80	FF	00-FF												
EB	POS95	POS94	POS93	POS92	POS91	POS90	POS89	POS88	FF	00-FF												
EC					POS99	POS98	POS97	POS96	FF	00-0F												
ED																						
EE	Blue Back	1/2 digit	TEXT				LANGUAGE			48	00-FF											
EF	LAST VOLUME								00	00-3C												
F0	POS 7	POS 6	POS 5	POS 4	POS 3	POS 2	POS 1	POS 0	01	00-FF												
F1	POS15	POS14	POS13	POS12	POS11	POS10	POS 9	POS 8	00	00-FF												
F2	POS23	POS22	POS21	POS20	POS19	POS18	POS17	POS16	00	00-FF												
F3	POS31	POS30	POS29	POS28	POS27	POS26	POS25	POS24	00	00-FF												
F4	POS39	POS38	POS37	POS36	POS35	POS34	POS33	POS32	00	00-FF												
F5	POS47	POS46	POS45	POS44	POS43	POS42	POS41	POS40	00	00-FF												
F6	POS55	POS54	POS53	POS52	POS51	POS50	POS49	POS48	00	00-FF												
F7	POS63	POS62	POS61	POS60	POS59	POS58	POS57	POS56	00	00-FF												
F8	POS71	POS70	POS69	POS68	POS67	POS66	POS65	POS64	00	00-FF												
F9	POS79	POS78	POS77	POS76	POS75	POS74	POS73	POS72	00	00-FF												
FA	POS87	POS86	POS85	POS84	POS83	POS82	POS81	POS80	00	00-FF												
FB	POS95	POS94	POS93	POS92	POS91	POS90	POS89	POS88	00	00-FF												
FC					POS99	POS98	POS97	POS96	00	00-0F												
FD	POWER								AA	AA(On), 5S(Off)												
FE	ON TIMER VOLUME								FF	00-3C, FF												
FF	ON TIMER CHANNEL								FF	00-65, FF												
MODEL								MODEL														
LETTER NO.								LETTER NO.														

MEMORY MAP (Continued)

SLAVE ADDRESS : A0(00-FF) A2(100-1FF) A4(200-2FF) A6(300-3FF) A8(400-4FF)

ADDRESS (HEX)	DATA								MICON DEFAULT	EEPROM RANGE	EEPROM WRITE(CPU)	CHASSIS		CTV FINAL		LAST INITIAL SETTING DATA	REMARK
	D7	D6	D5	D4	D3	D2	D1	D0				CHECK DATA	CHECK TYPE	CHECK DATA	CHECK TYPE		
140	ANT-BOOSTER (POS64)		S-SYSTEM (POS64)			C-SYSTEM (POS64)			00	00-9C							
141	ANT-BOOSTER (POS65)		S-SYSTEM (POS65)			C-SYSTEM (POS65)			00	00-34							
142	ANT-BOOSTER (POS66)		S-SYSTEM (POS66)			C-SYSTEM (POS66)			00	00-34							
143	ANT-BOOSTER (POS67)		S-SYSTEM (POS67)			C-SYSTEM (POS67)			00	00-34							
144	ANT-BOOSTER (POS68)		S-SYSTEM (POS68)			C-SYSTEM (POS68)			00	00-34							
145	ANT-BOOSTER (POS69)		S-SYSTEM (POS69)			C-SYSTEM (POS69)			00	00-34							
146	ANT-BOOSTER (POS70)		S-SYSTEM (POS70)			C-SYSTEM (POS70)			00	00-34							
147	ANT-BOOSTER (POS71)		S-SYSTEM (POS71)			C-SYSTEM (POS71)			00	00-34							
148	ANT-BOOSTER (POS72)		S-SYSTEM (POS72)			C-SYSTEM (POS72)			00	00-34							
149	ANT-BOOSTER (POS73)		S-SYSTEM (POS73)			C-SYSTEM (POS73)			00	00-34							
14A	ANT-BOOSTER (POS74)		S-SYSTEM (POS74)			C-SYSTEM (POS74)			00	00-34							
14B	ANT-BOOSTER (POS75)		S-SYSTEM (POS75)			C-SYSTEM (POS75)			00	00-34							
14C	ANT-BOOSTER (POS76)		S-SYSTEM (POS76)			C-SYSTEM (POS76)			00	00-34							
14D	ANT-BOOSTER (POS77)		S-SYSTEM (POS77)			C-SYSTEM (POS77)			00	00-34							
14E	ANT-BOOSTER (POS78)		S-SYSTEM (POS78)			C-SYSTEM (POS78)			00	00-34							
14F	ANT-BOOSTER (POS79)		S-SYSTEM (POS79)			C-SYSTEM (POS79)			00	00-34							
150	ANT-BOOSTER (POS80)		S-SYSTEM (POS80)			C-SYSTEM (POS80)			00	00-34							
151	ANT-BOOSTER (POS81)		S-SYSTEM (POS81)			C-SYSTEM (POS81)			00	00-34							
152	ANT-BOOSTER (POS82)		S-SYSTEM (POS82)			C-SYSTEM (POS82)			00	00-34							
153	ANT-BOOSTER (POS83)		S-SYSTEM (POS83)			C-SYSTEM (POS83)			00	00-34							
154	ANT-BOOSTER (POS84)		S-SYSTEM (POS84)			C-SYSTEM (POS84)			00	00-34							
155	ANT-BOOSTER (POS85)		S-SYSTEM (POS85)			C-SYSTEM (POS85)			00	00-34							
156	ANT-BOOSTER (POS86)		S-SYSTEM (POS86)			C-SYSTEM (POS86)			00	00-34							
157	ANT-BOOSTER (POS87)		S-SYSTEM (POS87)			C-SYSTEM (POS87)			00	00-34							
158	ANT-BOOSTER (POS88)		S-SYSTEM (POS88)			C-SYSTEM (POS88)			00	00-34							
159	ANT-BOOSTER (POS89)		S-SYSTEM (POS89)			C-SYSTEM (POS89)			00	00-34							
15A	ANT-BOOSTER (POS90)		S-SYSTEM (POS90)			C-SYSTEM (POS90)			00	00-34							
15B	ANT-BOOSTER (POS91)		S-SYSTEM (POS91)			C-SYSTEM (POS91)			00	00-34							
15C	ANT-BOOSTER (POS92)		S-SYSTEM (POS92)			C-SYSTEM (POS92)			00	00-34							
15D	ANT-BOOSTER (POS93)		S-SYSTEM (POS93)			C-SYSTEM (POS93)			00	00-34							
15E	ANT-BOOSTER (POS94)		S-SYSTEM (POS94)			C-SYSTEM (POS94)			00	00-34							
15F	ANT-BOOSTER (POS95)		S-SYSTEM (POS95)			C-SYSTEM (POS95)			00	00-34							
160	ANT-BOOSTER (POS96)		S-SYSTEM (POS96)			C-SYSTEM (POS96)			00	00-34							
161	ANT-BOOSTER (POS97)		S-SYSTEM (POS97)			C-SYSTEM (POS97)			00	00-34							
162	ANT-BOOSTER (POS98)		S-SYSTEM (POS98)			C-SYSTEM (POS98)			00	00-34							
163	ANT-BOOSTER (POS99)		S-SYSTEM (POS99)			C-SYSTEM (POS99)			00	00-34							
164	C-SYSTEM (AV2)				C-SYSTEM (AV1)				00	00-44							
165	SLV1 (HIGH)								00	00-FF							
166	SLV1 (LOW)								00	00-FF							
167	SLV2 (HIGH)								00	00-FF							
168	SLV2 (LOW)								00	00-FF							
169	SLV3 (HIGH)								00	00-FF							
16A	SLV3 (LOW)								00	00-FF							
16B	SLV4 (HIGH)								00	00-FF							
16C	SLV4 (LOW)								00	00-FF							
16D	SLV5 (HIGH)								00	00-FF							
16E	SLV5 (LOW)								00	00-FF							
16F	SLV6 (HIGH)								00	00-FF							
170	SLV6 (LOW)								00	00-FF							
171	SLV7 (HIGH)								00	00-FF							
172	SLV7 (LOW)								00	00-FF							
173	TV/AV								00	0(TV), 1(AV1), 2(AV2)							
174	LAST CHANNEL POSITION								01	00-63							
175	FLASH BACK POSITION								01	00-FF							
176	ROM CORRECTION-1 ID									00-FF						Valid (A0)	
177	ROM CORRECTION-1 HIGH BYTE ADDRESS									00-FF							
178	ROM CORRECTION-1 LOW BYTE ADDRESS									00-FF							
179	ROM CORRECTION-1 DATA LENGTH									00-FF							
17A	ROM CORRECTION-1 CHECKSUM									00-FF							
17B	ROM CORRECTION-2 ID									00-FF						Valid (A0)	
17C	ROM CORRECTION-2 HIGH BYTE ADDRESS									00-FF							
17D	ROM CORRECTION-2 LOW BYTE ADDRESS									00-FF							
17E	ROM CORRECTION-2 DATA LENGTH									00-FF							
17F	ROM CORRECTION-2 CHECKSUM									00-FF							
MODEL								MODEL									
LETTER NO.								LETTER NO.									

MEMORY MAP (Continued)

SLAVE ADDRESS : A0(00-FF) A2(100-1FF) A4(200-2FF) A6(300-3FF) A8(400-4FF)

ADDRESS (HEX)	DATA								MICON DEFAULT	EEPROM RANGE	EEPROM WRITE(CPU)	CHASSIS		CTV FINAL		LAST INITIAL SETTING DATA	REMARK
	D7	D6	D5	D4	D3	D2	D1	D0				CHECK DATA	CHECK TYPE	CHECK DATA	CHECK TYPE		
180										00-FF							
181										00-FF							
182										00-FF							
183										00-FF							
184										00-FF							
185										00-FF							
186										00-FF							
187										00-FF							
188										00-FF							
189										00-FF							
18A										00-FF							
18B										00-FF							
18C										00-FF							
18D										00-FF							
18E										00-FF							
18F										00-FF							
190										00-FF							
191										00-FF							
192										00-FF							
193										00-FF							
194										00-FF							
195										00-FF							
196										00-FF							
197										00-FF							
198										00-FF							
199										00-FF							
19A										00-FF							
19B										00-FF							
19C										00-FF							
19D										00-FF							
19E										00-FF							
19F										00-FF							
1A0										00-FF							
1A1										00-FF							
1A2										00-FF							
1A3										00-FF							
1A4										00-FF							
1A5										00-FF							
1A6										00-FF							
1A7										00-FF							
1A8										00-FF							
1A9										00-FF							
1AA										00-FF							
1AB										00-FF							
1AC										00-FF							
1AD										00-FF							
1AE										00-FF							
1AF										00-FF							
1B0										00-FF							
1B1										00-FF							
1B2										00-FF							
1B3										00-FF							
1B4										00-FF							
1B5										00-FF							
1B6										00-FF							
1B7										00-FF							
1B8										00-FF							
1B9										00-FF							
1BA										00-FF							
1BB										00-FF							
1BC										00-FF							
1BD										00-FF							
1BE										00-FF							
1BF										00-FF							
MODEL								MODEL									
LETTER NO.								LETTER NO.									

MEMORY MAP (Continued)

SLAVE ADDRESS : A0(00-FF) A2(100-1FF) A4(200-2FF) A6(300-3FF) A8(400-4FF)

ADDRESS (HEX)	DATA								MICON DEFAULT	EEPROM RANGE	EEPROM WRITE(CPU)	CHASSIS		CTV FINAL		LAST INITIAL SETTING DATA	REMARK
	D7	D6	D5	D4	D3	D2	D1	D0				CHECK DATA	CHECK TYPE	CHECK DATA	CHECK TYPE		
1C0									FF	00-FF							
1C1									FF	00-FF							
1C2									FF	00-FF							
1C3									FF	00-FF							
1C4									FF	00-FF							
1C5									FF	00-FF							
1C6									FF	00-FF							
1C7									FF	00-FF							
1C8									FF	00-FF							
1C9									FF	00-FF							
1CA									FF	00-FF							
1CB									FF	00-FF							
1CC									FF	00-FF							
1CD									FF	00-FF							
1CE									FF	0-FF							
1CF									FF	0-FF							
1D0									FF	0-FF							
1D1									FF	0-FF							
1D2									FF	0-FF							
1D3									FF	0-FF							
1D4									FF	0-FF							
1D5									FF	0-FF							
1D6									FF	0-FF							
1D7									FF	0-FF							
1D8									FF	0-FF							
1D9									FF	0-FF							
1DA									FF	0-FF							
1DB									FF	0-FF							
1DC									FF	0-FF							
1DD									FF	0-FF							
1DE									FF	0-FF							
1DF									FF	0-FF							
1E0									FF	0-FF							
1E1									FF	0-FF							
1E2									FF	0-FF							
1E3									FF	0-FF							
1E4									FF	0-FF							
1E5									FF	0-FF							
1E6									FF	0-FF							
1E7									FF	0-FF							
1E8									FF	0-FF							
1E9									FF	0-FF							
1EA									FF	0-FF							
1EB									FF	0-FF							
1EC									FF	0-FF							
1ED									FF	0-FF							
1EE									FF	0-FF							
1EF									FF	0-FF							
1F0									FF	0-FF							
1F1									FF	0-FF							
1F2									FF	0-FF							
1F3									FF	0-FF							
1F4									FF	0-FF							
1F5									FF	0-FF							
1F6									FF	0-FF							
1F7									FF	0-FF							
1F8									FF	0-FF							
1F9									FF	0-FF							
1FA									FF	0-FF							
1FB									FF	0-FF							
1FC									FF	0-FF							
1FD									FF	0-FF							
1FE									FF	0-FF							
1FF									FF	0-FF							
MODEL									MODEL								
LETTER NO.									LETTER NO.								

1) Add new area for Message Data for Favorite Message Three.

21J-FG1RU

MEMORY MAP (Continued)

SLAVE ADDRESS : A0(00-FF) A2(100-1FF) A4(200-2FF) A6(300-3FF) A8(400-4FF)

ADDRESS (HEX)	DATA							MICON DEFAULT	EEPROM RANGE	EEPROM WRITE(CPU)	CHASSIS		CTV FINAL		LAST INITIAL SETTING DATA	REMARK				
	D7	D6	D5	D4	D3	D2	D1				D0	CHECK DATA	CHECK TYPE	CHECK DATA			CHECK TYPE			
200								3F	00-7F											
201								3F	00-7F											
202								7F	00-FF											
203								7F	00-FF											
204								7F	00-FF											
205								32	00-7F											
206								1F	00-3F											
207								03	00-07											
208								64	00-7F											
209								3F	00-7F											
20A								7F	00-FF											
20B								3F	00-7F											
20C								2B	00-3F											
20D								5A	00-7F											
20E								3F	00-7F											
20F								26	00-3F											
210								03	00-07											
211								09	00-1F											
212								25	00-3F											
213								16	00-3F											
214								3C	00-3C											
215								1F	00-3E											
216								06	00-0E											
217								11	00-1E											
218								07	00-0F											
219								07	00-0F											
21A								07	00-0F											
21B								07	00-0F											
21C								07	00-0F											
21D								3F	00-7F							(1) New Item V25				
21E								3F	00-7F							(1) New Item V25				
21F								7F	00-FF							(1) New Item V25				
220								7F	00-FF							(1) New Item V25				
221								7F	00-FF							(1) New Item V25				
222								64	00-7F							(1) New Item V26				
223								7F	00-FF							(1) New Item V27				
224								20	00-3F											
225								0D	00-1A											
226								20	00-3F											
227								0D	00-1A											
228																				
229																				
22A																				
22B																				
22C								5F	00-7F											
22D								04	00-07											
22E								05	00-07											
22F								05	00-07											
230								07	00-07											
231								05	00-07											
232								05	00-07											
233								06	00-07											
234								06	00-07											
235								07	00-07											
236								06	00-07											
237								06	00-07											
238								06	00-07											
239								29	00-3E											
23A								1F	00-3E											
23B								28	00-3E											
23C								17	00-3E											
23D								18	00-3E											
23E								1F	00-3E											
23F								24	00-3E											
MODEL								MODEL												
LETTER NO.								LETTER NO.												

MEMORY MAP (Continued)

SLAVE ADDRESS : A0(00-FF) A2(100-1FF) A4(200-2FF) A6(300-3FF) A8(400-4FF)

ADDRESS (HEX)	DATA							MICON DEFAULT	EEPROM RANGE	EEPROM WRITE(CPU)	CHASSIS		CTV FINAL		LAST INITIAL SETTING DATA	REMARK
	D7	D6	D5	D4	D3	D2	D1				D0	CHECK DATA	CHECK TYPE	CHECK DATA		
2C0								FF	0-FF							
2C1								FF	0-FF							
2C2								FF	0-FF							
2C3								FF	0-FF							
2C4								FF	0-FF							
2C5								FF	0-FF							
2C6								FF	0-FF							
2C7								FF	0-FF							
2C8								FF	0-FF							
2C9								FF	0-FF							
2CA								FF	0-FF							
2CB								FF	0-FF							
2CC								FF	0-FF							
2CD								FF	0-FF							
2CE								FF	0-FF							
2CF								FF	0-FF							
2D0								FF	0-FF							
2D1								FF	0-FF							
2D2								FF	0-FF							
2D3								FF	0-FF							
2D4								FF	0-FF							
2D5								FF	0-FF							
2D6								FF	0-FF							
2D7								FF	0-FF							
2D8								FF	0-FF							
2D9								FF	0-FF							
2DA								FF	0-FF							
2DB								FF	0-FF							
2DC								FF	0-FF							
2DD								FF	0-FF							
2DE								FF	0-FF							
2DF								FF	0-FF							
2E0								FF	0-FF							
2E1								FF	0-FF							
2E2								FF	0-FF							
2E3								FF	0-FF							
2E4								FF	0-FF							
2E5								FF	0-FF							
2E6								FF	0-FF							
2E7								FF	0-FF							
2E8								FF	0-FF							
2E9								FF	0-FF							
2EA								FF	0-FF							
2EB								FF	0-FF							
2EC								FF	0-FF							
2ED								FF	0-FF							
2EE								FF	0-FF							
2EF								FF	0-FF							
2F0								FF	0-FF							
2F1								FF	0-FF							
2F2								FF	0-FF							
2F3								FF	0-FF							
2F4								FF	0-FF							
2F5								FF	0-FF							
2F6								FF	0-FF							
2F7								FF	0-FF							
2F8								FF	0-FF							
2F9								FF	0-FF							
2FA								FF	0-FF							
2FB								FF	0-FF							
2FC								FF	0-FF							
2FD								FF	0-FF							
2FE								FF	0-FF							
2FF								FF	0-FF							
1) Add new area for Message Data for Inbox Message.																
MODEL								MODEL								
LETTER NO.								LETTER NO.								

*1 0 : individually selectable rating system 1 : threshold selectable rating system
 *2 0 : CATEGORY bit mask with (01,05) 1st character 1 : CATEGORY bit mask with (01,05) 2nd character

MEMORY MAP (Continued)

SLAVE ADDRESS : A0(00-FF) A2(100-1FF) A4(200-2FF) A6(300-3FF) A8(400-4FF)

ADDRESS (HEX)	DATA								MICON DEFAULT	EEPROM RANGE	EEPROM WRITE(CPU)	CHASSIS		CTV FINAL		LAST INITIAL SETTING DATA	REMARK					
	D7	D6	D5	D4	D3	D2	D1	D0				CHECK DATA	CHECK TYPE	CHECK DATA	CHECK TYPE							
300	A2 FM	A2 ST	A2 BIL1	NCM FM	NCM MONO	NCM ST	NCM BIL2	NCM BIL1	4C	00-FF						POS 0						
301	A2 FM	A2 ST	A2 BIL1	NCM FM	NCM MONO	NCM ST	NCM BIL2	NCM BIL1	4C	00-FF						POS 1						
302	A2 FM	A2 ST	A2 BIL1	NCM FM	NCM MONO	NCM ST	NCM BIL2	NCM BIL1	4C	00-FF						POS 2						
303	A2 FM	A2 ST	A2 BIL1	NCM FM	NCM MONO	NCM ST	NCM BIL2	NCM BIL1	4C	00-FF						POS 3						
304	A2 FM	A2 ST	A2 BIL1	NCM FM	NCM MONO	NCM ST	NCM BIL2	NCM BIL1	4C	00-FF						POS 4						
305	A2 FM	A2 ST	A2 BIL1	NCM FM	NCM MONO	NCM ST	NCM BIL2	NCM BIL1	4C	00-FF						POS 5						
306	A2 FM	A2 ST	A2 BIL1	NCM FM	NCM MONO	NCM ST	NCM BIL2	NCM BIL1	4C	00-FF						POS 6						
307	A2 FM	A2 ST	A2 BIL1	NCM FM	NCM MONO	NCM ST	NCM BIL2	NCM BIL1	4C	00-FF						POS 7						
308	A2 FM	A2 ST	A2 BIL1	NCM FM	NCM MONO	NCM ST	NCM BIL2	NCM BIL1	4C	00-FF						POS 8						
309	A2 FM	A2 ST	A2 BIL1	NCM FM	NCM MONO	NCM ST	NCM BIL2	NCM BIL1	4C	00-FF						POS 9						
30A	A2 FM	A2 ST	A2 BIL1	NCM FM	NCM MONO	NCM ST	NCM BIL2	NCM BIL1	4C	00-FF						POS 10						
30B	A2 FM	A2 ST	A2 BIL1	NCM FM	NCM MONO	NCM ST	NCM BIL2	NCM BIL1	4C	00-FF						POS 11						
30C	A2 FM	A2 ST	A2 BIL1	NCM FM	NCM MONO	NCM ST	NCM BIL2	NCM BIL1	4C	00-FF						POS 12						
30D	A2 FM	A2 ST	A2 BIL1	NCM FM	NCM MONO	NCM ST	NCM BIL2	NCM BIL1	4C	00-FF						POS 13						
30E	A2 FM	A2 ST	A2 BIL1	NCM FM	NCM MONO	NCM ST	NCM BIL2	NCM BIL1	4C	00-FF						POS 14						
30F	A2 FM	A2 ST	A2 BIL1	NCM FM	NCM MONO	NCM ST	NCM BIL2	NCM BIL1	4C	00-FF						POS 15						
310	A2 FM	A2 ST	A2 BIL1	NCM FM	NCM MONO	NCM ST	NCM BIL2	NCM BIL1	4C	00-FF						POS 16						
311	A2 FM	A2 ST	A2 BIL1	NCM FM	NCM MONO	NCM ST	NCM BIL2	NCM BIL1	4C	00-FF						POS 17						
312	A2 FM	A2 ST	A2 BIL1	NCM FM	NCM MONO	NCM ST	NCM BIL2	NCM BIL1	4C	00-FF						POS 18						
313	A2 FM	A2 ST	A2 BIL1	NCM FM	NCM MONO	NCM ST	NCM BIL2	NCM BIL1	4C	00-FF						POS 19						
314	A2 FM	A2 ST	A2 BIL1	NCM FM	NCM MONO	NCM ST	NCM BIL2	NCM BIL1	4C	00-FF						POS 20						
315	A2 FM	A2 ST	A2 BIL1	NCM FM	NCM MONO	NCM ST	NCM BIL2	NCM BIL1	4C	00-FF						POS 21						
316	A2 FM	A2 ST	A2 BIL1	NCM FM	NCM MONO	NCM ST	NCM BIL2	NCM BIL1	4C	00-FF						POS 22						
317	A2 FM	A2 ST	A2 BIL1	NCM FM	NCM MONO	NCM ST	NCM BIL2	NCM BIL1	4C	00-FF						POS 23						
318	A2 FM	A2 ST	A2 BIL1	NCM FM	NCM MONO	NCM ST	NCM BIL2	NCM BIL1	4C	00-FF						POS 24						
319	A2 FM	A2 ST	A2 BIL1	NCM FM	NCM MONO	NCM ST	NCM BIL2	NCM BIL1	4C	00-FF						POS 25						
31A	A2 FM	A2 ST	A2 BIL1	NCM FM	NCM MONO	NCM ST	NCM BIL2	NCM BIL1	4C	00-FF						POS 26						
31B	A2 FM	A2 ST	A2 BIL1	NCM FM	NCM MONO	NCM ST	NCM BIL2	NCM BIL1	4C	00-FF						POS 27						
31C	A2 FM	A2 ST	A2 BIL1	NCM FM	NCM MONO	NCM ST	NCM BIL2	NCM BIL1	4C	00-FF						POS 28						
31D	A2 FM	A2 ST	A2 BIL1	NCM FM	NCM MONO	NCM ST	NCM BIL2	NCM BIL1	4C	00-FF						POS 29						
31E	A2 FM	A2 ST	A2 BIL1	NCM FM	NCM MONO	NCM ST	NCM BIL2	NCM BIL1	4C	00-FF						POS 30						
31F	A2 FM	A2 ST	A2 BIL1	NCM FM	NCM MONO	NCM ST	NCM BIL2	NCM BIL1	4C	00-FF						POS 31						
320	A2 FM	A2 ST	A2 BIL1	NCM FM	NCM MONO	NCM ST	NCM BIL2	NCM BIL1	4C	00-FF						POS 32						
321	A2 FM	A2 ST	A2 BIL1	NCM FM	NCM MONO	NCM ST	NCM BIL2	NCM BIL1	4C	00-FF						POS 33						
322	A2 FM	A2 ST	A2 BIL1	NCM FM	NCM MONO	NCM ST	NCM BIL2	NCM BIL1	4C	00-FF						POS 34						
323	A2 FM	A2 ST	A2 BIL1	NCM FM	NCM MONO	NCM ST	NCM BIL2	NCM BIL1	4C	00-FF						POS 35						
324	A2 FM	A2 ST	A2 BIL1	NCM FM	NCM MONO	NCM ST	NCM BIL2	NCM BIL1	4C	00-FF						POS 36						
325	A2 FM	A2 ST	A2 BIL1	NCM FM	NCM MONO	NCM ST	NCM BIL2	NCM BIL1	4C	00-FF						POS 37						
326	A2 FM	A2 ST	A2 BIL1	NCM FM	NCM MONO	NCM ST	NCM BIL2	NCM BIL1	4C	00-FF						POS 38						
327	A2 FM	A2 ST	A2 BIL1	NCM FM	NCM MONO	NCM ST	NCM BIL2	NCM BIL1	4C	00-FF						POS 39						
328	A2 FM	A2 ST	A2 BIL1	NCM FM	NCM MONO	NCM ST	NCM BIL2	NCM BIL1	4C	00-FF						POS 40						
329	A2 FM	A2 ST	A2 BIL1	NCM FM	NCM MONO	NCM ST	NCM BIL2	NCM BIL1	4C	00-FF						POS 41						
32A	A2 FM	A2 ST	A2 BIL1	NCM FM	NCM MONO	NCM ST	NCM BIL2	NCM BIL1	4C	00-FF						POS 42						
32B	A2 FM	A2 ST	A2 BIL1	NCM FM	NCM MONO	NCM ST	NCM BIL2	NCM BIL1	4C	00-FF						POS 43						
32C	A2 FM	A2 ST	A2 BIL1	NCM FM	NCM MONO	NCM ST	NCM BIL2	NCM BIL1	4C	00-FF						POS 44						
32D	A2 FM	A2 ST	A2 BIL1	NCM FM	NCM MONO	NCM ST	NCM BIL2	NCM BIL1	4C	00-FF						POS 45						
32E	A2 FM	A2 ST	A2 BIL1	NCM FM	NCM MONO	NCM ST	NCM BIL2	NCM BIL1	4C	00-FF						POS 46						
32F	A2 FM	A2 ST	A2 BIL1	NCM FM	NCM MONO	NCM ST	NCM BIL2	NCM BIL1	4C	00-FF						POS 47						
330	A2 FM	A2 ST	A2 BIL1	NCM FM	NCM MONO	NCM ST	NCM BIL2	NCM BIL1	4C	00-FF						POS 48						
331	A2 FM	A2 ST	A2 BIL1	NCM FM	NCM MONO	NCM ST	NCM BIL2	NCM BIL1	4C	00-FF						POS 49						
332	A2 FM	A2 ST	A2 BIL1	NCM FM	NCM MONO	NCM ST	NCM BIL2	NCM BIL1	4C	00-FF						POS 50						
333	A2 FM	A2 ST	A2 BIL1	NCM FM	NCM MONO	NCM ST	NCM BIL2	NCM BIL1	4C	00-FF						POS 51						
334	A2 FM	A2 ST	A2 BIL1	NCM FM	NCM MONO	NCM ST	NCM BIL2	NCM BIL1	4C	00-FF						POS 52						
335	A2 FM	A2 ST	A2 BIL1	NCM FM	NCM MONO	NCM ST	NCM BIL2	NCM BIL1	4C	00-FF						POS 53						
336	A2 FM	A2 ST	A2 BIL1	NCM FM	NCM MONO	NCM ST	NCM BIL2	NCM BIL1	4C	00-FF						POS 54						
337	A2 FM	A2 ST	A2 BIL1	NCM FM	NCM MONO	NCM ST	NCM BIL2	NCM BIL1	4C	00-FF						POS 55						
338	A2 FM	A2 ST	A2 BIL1	NCM FM	NCM MONO	NCM ST	NCM BIL2	NCM BIL1	4C	00-FF						POS 56						
339	A2 FM	A2 ST	A2 BIL1	NCM FM	NCM MONO	NCM ST	NCM BIL2	NCM BIL1	4C	00-FF						POS 57						
33A	A2 FM	A2 ST	A2 BIL1	NCM FM	NCM MONO	NCM ST	NCM BIL2	NCM BIL1	4C	00-FF						POS 58						
33B	A2 FM	A2 ST	A2 BIL1	NCM FM	NCM MONO	NCM ST	NCM BIL2	NCM BIL1	4C	00-FF						POS 59						
33C	A2 FM	A2 ST	A2 BIL1	NCM FM	NCM MONO	NCM ST	NCM BIL2	NCM BIL1	4C	00-FF						POS 60						
33D	A2 FM	A2 ST	A2 BIL1	NCM FM	NCM MONO	NCM ST	NCM BIL2	NCM BIL1	4C	00-FF						POS 61						
33E	A2 FM	A2 ST	A2 BIL1	NCM FM	NCM MONO	NCM ST	NCM BIL2	NCM BIL1	4C	00-FF						POS 62						
33F	A2 FM	A2 ST	A2 BIL1	NCM FM	NCM MONO	NCM ST	NCM BIL2	NCM BIL1	4C	00-FF						POS 63						
MODEL								MODEL														
LETTER NO.								LETTER NO.														

MEMORY MAP (Continued)

SLAVE ADDRESS : A0(00-FF) A2(100-1FF) A4(200-2FF) A6(300-3FF) A8(400-4FF)

ADDRESS (HEX)	DATA								MICON DEFAULT	EEPROM RANGE	EEPROM WRITE(CPU)	CHASSIS		CTV FINAL		LAST INITIAL SETTING DATA	REMARK
	D7	D6	D5	D4	D3	D2	D1	D0				CHECK DATA	CHECK TYPE	CHECK DATA	CHECK TYPE		
340	A2 FM	A2 ST	A2 BIL1	NCM FM	NCM MONO	NCM ST	NCM BIL2	NCM BIL1	4C	00-FF						POS 64	
341	A2 FM	A2 ST	A2 BIL1	NCM FM	NCM MONO	NCM ST	NCM BIL2	NCM BIL1	4C	00-FF						POS 65	
342	A2 FM	A2 ST	A2 BIL1	NCM FM	NCM MONO	NCM ST	NCM BIL2	NCM BIL1	4C	00-FF						POS 66	
343	A2 FM	A2 ST	A2 BIL1	NCM FM	NCM MONO	NCM ST	NCM BIL2	NCM BIL1	4C	00-FF						POS 67	
344	A2 FM	A2 ST	A2 BIL1	NCM FM	NCM MONO	NCM ST	NCM BIL2	NCM BIL1	4C	00-FF						POS 68	
345	A2 FM	A2 ST	A2 BIL1	NCM FM	NCM MONO	NCM ST	NCM BIL2	NCM BIL1	4C	00-FF						POS 69	
346	A2 FM	A2 ST	A2 BIL1	NCM FM	NCM MONO	NCM ST	NCM BIL2	NCM BIL1	4C	00-FF						POS 70	
347	A2 FM	A2 ST	A2 BIL1	NCM FM	NCM MONO	NCM ST	NCM BIL2	NCM BIL1	4C	00-FF						POS 71	
348	A2 FM	A2 ST	A2 BIL1	NCM FM	NCM MONO	NCM ST	NCM BIL2	NCM BIL1	4C	00-FF						POS 72	
349	A2 FM	A2 ST	A2 BIL1	NCM FM	NCM MONO	NCM ST	NCM BIL2	NCM BIL1	4C	00-FF						POS 73	
34A	A2 FM	A2 ST	A2 BIL1	NCM FM	NCM MONO	NCM ST	NCM BIL2	NCM BIL1	4C	00-FF						POS 74	
34B	A2 FM	A2 ST	A2 BIL1	NCM FM	NCM MONO	NCM ST	NCM BIL2	NCM BIL1	4C	00-FF						POS 75	
34C	A2 FM	A2 ST	A2 BIL1	NCM FM	NCM MONO	NCM ST	NCM BIL2	NCM BIL1	4C	00-FF						POS 76	
34D	A2 FM	A2 ST	A2 BIL1	NCM FM	NCM MONO	NCM ST	NCM BIL2	NCM BIL1	4C	00-FF						POS 77	
34E	A2 FM	A2 ST	A2 BIL1	NCM FM	NCM MONO	NCM ST	NCM BIL2	NCM BIL1	4C	00-FF						POS 78	
34F	A2 FM	A2 ST	A2 BIL1	NCM FM	NCM MONO	NCM ST	NCM BIL2	NCM BIL1	4C	00-FF						POS 79	
350	A2 FM	A2 ST	A2 BIL1	NCM FM	NCM MONO	NCM ST	NCM BIL2	NCM BIL1	4C	00-FF						POS 80	
351	A2 FM	A2 ST	A2 BIL1	NCM FM	NCM MONO	NCM ST	NCM BIL2	NCM BIL1	4C	00-FF						POS 81	
352	A2 FM	A2 ST	A2 BIL1	NCM FM	NCM MONO	NCM ST	NCM BIL2	NCM BIL1	4C	00-FF						POS 82	
353	A2 FM	A2 ST	A2 BIL1	NCM FM	NCM MONO	NCM ST	NCM BIL2	NCM BIL1	4C	00-FF						POS 83	
354	A2 FM	A2 ST	A2 BIL1	NCM FM	NCM MONO	NCM ST	NCM BIL2	NCM BIL1	4C	00-FF						POS 84	
355	A2 FM	A2 ST	A2 BIL1	NCM FM	NCM MONO	NCM ST	NCM BIL2	NCM BIL1	4C	00-FF						POS 85	
356	A2 FM	A2 ST	A2 BIL1	NCM FM	NCM MONO	NCM ST	NCM BIL2	NCM BIL1	4C	00-FF						POS 86	
357	A2 FM	A2 ST	A2 BIL1	NCM FM	NCM MONO	NCM ST	NCM BIL2	NCM BIL1	4C	00-FF						POS 87	
358	A2 FM	A2 ST	A2 BIL1	NCM FM	NCM MONO	NCM ST	NCM BIL2	NCM BIL1	4C	00-FF						POS 88	
359	A2 FM	A2 ST	A2 BIL1	NCM FM	NCM MONO	NCM ST	NCM BIL2	NCM BIL1	4C	00-FF						POS 89	
35A	A2 FM	A2 ST	A2 BIL1	NCM FM	NCM MONO	NCM ST	NCM BIL2	NCM BIL1	4C	00-FF						POS 90	
35B	A2 FM	A2 ST	A2 BIL1	NCM FM	NCM MONO	NCM ST	NCM BIL2	NCM BIL1	4C	00-FF						POS 91	
35C	A2 FM	A2 ST	A2 BIL1	NCM FM	NCM MONO	NCM ST	NCM BIL2	NCM BIL1	4C	00-FF						POS 92	
35D	A2 FM	A2 ST	A2 BIL1	NCM FM	NCM MONO	NCM ST	NCM BIL2	NCM BIL1	4C	00-FF						POS 93	
35E	A2 FM	A2 ST	A2 BIL1	NCM FM	NCM MONO	NCM ST	NCM BIL2	NCM BIL1	4C	00-FF						POS 94	
35F	A2 FM	A2 ST	A2 BIL1	NCM FM	NCM MONO	NCM ST	NCM BIL2	NCM BIL1	4C	00-FF						POS 95	
360	A2 FM	A2 ST	A2 BIL1	NCM FM	NCM MONO	NCM ST	NCM BIL2	NCM BIL1	4C	00-FF						POS 96	
361	A2 FM	A2 ST	A2 BIL1	NCM FM	NCM MONO	NCM ST	NCM BIL2	NCM BIL1	4C	00-FF						POS 97	
362	A2 FM	A2 ST	A2 BIL1	NCM FM	NCM MONO	NCM ST	NCM BIL2	NCM BIL1	4C	00-FF						POS 98	
363	A2 FM	A2 ST	A2 BIL1	NCM FM	NCM MONO	NCM ST	NCM BIL2	NCM BIL1	4C	00-FF						POS 99	
364																	
365																	
366																	
367																	
368									FF	0-FF							
369									FF	0-FF							
36A									FF	0-FF							
36B									FF	0-FF							
36C									FF	0-FF							
36D									FF	0-FF						1) Add in for Favorite Message Three.	
36E									FF	0-FF							
36F									FF	0-FF							
370									FF	0-FF							
371									FF	0-FF							
372									FF	0-FF							
373									FF	0-FF							
374									FF	0-FF							
375									FF	0-FF							
376									FF	0-FF						1) Add in for Favorite Message Two.	
377									FF	0-FF							
378									FF	0-FF							
379									FF	0-FF							
37A									FF	0-FF							
37B									FF	0-FF							
37C									FF	0-FF							
37D									FF	0-FF							
37E									FF	0-FF						1) Add in for Favorite Message One.	
37F									FF	0-FF							
	MODEL								MODEL								
	LETTER NO.								LETTER NO.								

MEMORY MAP (Continued)

SLAVE ADDRESS : A0(00-FF) A2(100-1FF) A4(200-2FF) A6(300-3FF) A8(400-4FF)

ADDRESS (HEX)	DATA						MICON DEFAULT	EEPROM RANGE	EEPROM WRITE(CPU)	CHASSIS		CTV FINAL		LAST INITIAL SETTING DATA	REMARK
	D7	D6	D5	D4	D3	D2				D1	D0	CHECK DATA	CHECK TYPE		
380								FF	00-FF						
381								FF	00-FF						
382								FF	0-FF						
383								FF	0-FF						
384								FF	0-FF						
385								FF	0-FF						
386								FF	0-FF						
387								FF	0-FF						
388								FF	0-FF						
389								FF	0-FF						
38A								FF	0-FF						
38B								FF	0-FF						
38C								FF	0-FF						
38D								FF	0-FF						
38E								FF	0-FF						
38F								FF	0-FF						
390								FF	0-FF						
391								FF	0-FF						
392								FF	0-FF						
393								FF	0-FF						
394								FF	0-FF						
395								FF	0-FF						
396								FF	0-FF						
397								FF	0-FF						
398								FF	0-FF						
399								FF	0-FF						
39A								FF	0-FF						
39B								FF	0-FF						
39C								FF	0-FF						
39D								FF	0-FF						
39E								FF	0-FF						
39F								FF	0-FF						
3A0								FF	0-FF						
3A1								FF	0-FF						
3A2								FF	0-FF						
3A3								FF	0-FF						
3A4								FF	0-FF						
3A5								FF	0-FF						
3A6								FF	0-FF						
3A7								FF	0-FF						
3A8								FF	0-FF						
3A9								FF	0-FF						
3AA								FF	0-FF						
3AB								FF	0-FF						
3AC								FF	0-FF						
3AD								FF	0-FF						
3AE								FF	0-FF						
3AF								FF	0-FF						
3B0								FF	0-FF						
3B1								FF	0-FF						
3B2								FF	0-FF						
3B3								FF	0-FF						
3B4								FF	0-FF						
3B5								FF	0-FF						
3B6								FF	0-FF						
3B7								FF	0-FF						
3B8								FF	0-FF						
3B9								FF	0-FF						
3BA								FF	0-FF						
3BB								FF	0-FF						
3BC								FF	0-FF						
3BD								FF	0-FF						
3BE								FF	0-FF						
3BF								FF	0-FF						
MODEL								MODEL							
LETTER NO.								LETTER NO.							

1) Add new area for Message Data for Favorite Message One.

MEMORY MAP (Continued)

SLAVE ADDRESS : A0(00-FF) A2(100-1FF) A4(200-2FF) A6(300-3FF) A8(400-4FF)

ADDRESS (HEX)	DATA								MICON DEFAULT	EEPROM RANGE	EEPROM WRITE(CPU)	CHASSIS		CTV FINAL		LAST INITIAL SETTING DATA	REMARK
	D7	D6	D5	D4	D3	D2	D1	D0				CHECK DATA	CHECK TYPE	CHECK DATA	CHECK TYPE		
3C0									FF	0-FF							
3C1									FF	0-FF							
3C2									FF	0-FF							
3C3									FF	0-FF							
3C4									FF	0-FF							
3C5									FF	0-FF							
3C6									FF	0-FF							
3C7									FF	0-FF							
3C8									FF	0-FF							
3C9									FF	0-FF							
3CA									FF	0-FF							
3CB									FF	0-FF							
3CC									FF	0-FF							
3CD									FF	0-FF							
3CE									FF	0-FF							
3CF									FF	0-FF							
3D0									FF	0-FF							
3D1									FF	0-FF							
3D2									FF	0-FF							
3D3									FF	0-FF							
3D4									FF	0-FF							
3D5									FF	0-FF							
3D6									FF	0-FF							
3D7									FF	0-FF							
3D8									FF	0-FF							
3D9									FF	0-FF							
3DA									FF	0-FF							
3DB									FF	0-FF							
3DC									FF	0-FF							
3DD									FF	0-FF							
3DE									FF	0-FF							
3DF									FF	0-FF							
3E0									FF	0-FF							
3E1									FF	0-FF							
3E2									FF	0-FF							
3E3									FF	0-FF							
3E4									FF	0-FF							
3E5									FF	0-FF							
3E6									FF	0-FF							
3E7									FF	0-FF							
3E8									FF	0-FF							
3E9									FF	0-FF							
3EA									FF	0-FF							
3EB									FF	0-FF							
3EC									FF	0-FF							
3ED									FF	0-FF							
3EE									FF	0-FF							
3EF									FF	0-FF							
3F0									FF	0-FF							
3F1									FF	0-FF							
3F2									FF	0-FF							
3F3									FF	0-FF							
3F4									FF	0-FF							
3F5									FF	0-FF							
3F6									FF	0-FF							
3F7									FF	0-FF							
3F8									FF	0-FF							
3F9									FF	0-FF							
3FA									FF	0-FF							
3FB									FF	0-FF							
3FC									FF	0-FF							
3FD									FF	0-FF							
3FE									FF	0-FF							
3FF									FF	0-FF							
MODEL									MODEL								
LETTER NO.									LETTER NO.								

1) Add new area for Message Data for Favorite Message Two.

CHAPTER 5. TROUBLE SHOOTING FLOWCHART

[1] TROUBLE SHOOTING FLOWCHART

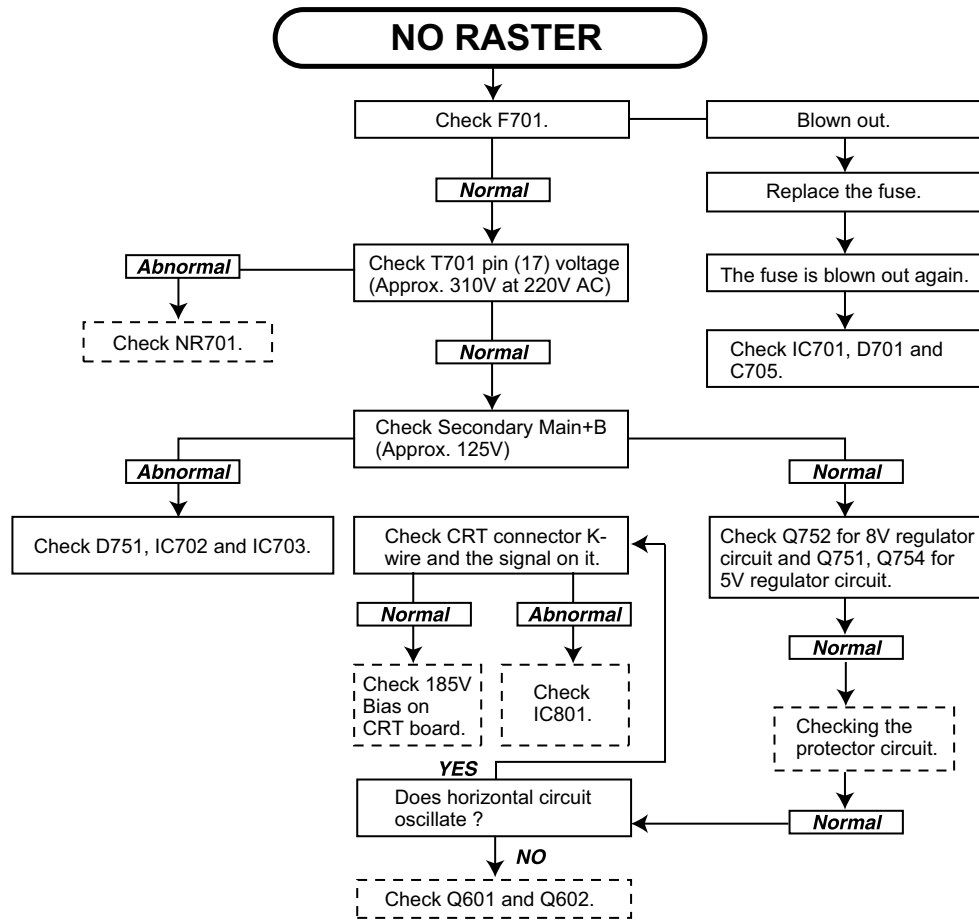

CIRCUITS TO BE CHECKED:

- Tuner.
- PIF.
- Automatic Gain Control.
- (5V), (32V) Power Source.

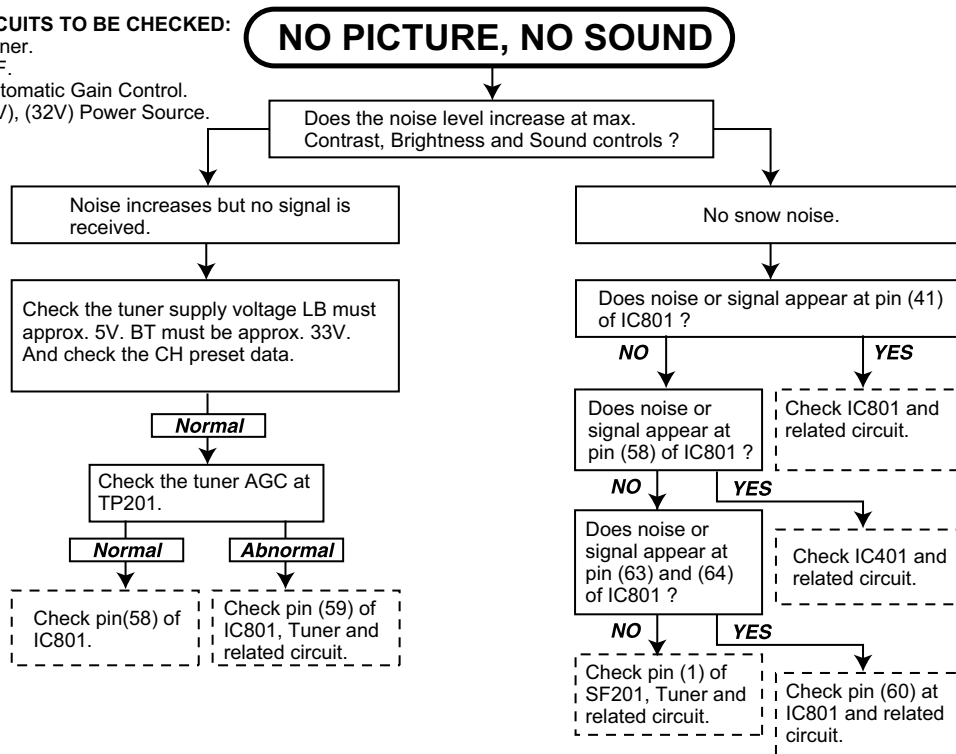

CIRCUITS TO BE CHECKED:

- Sound Detector Circuit.
- Sound Switch and Att. Control.
- Audio Output Circuit.

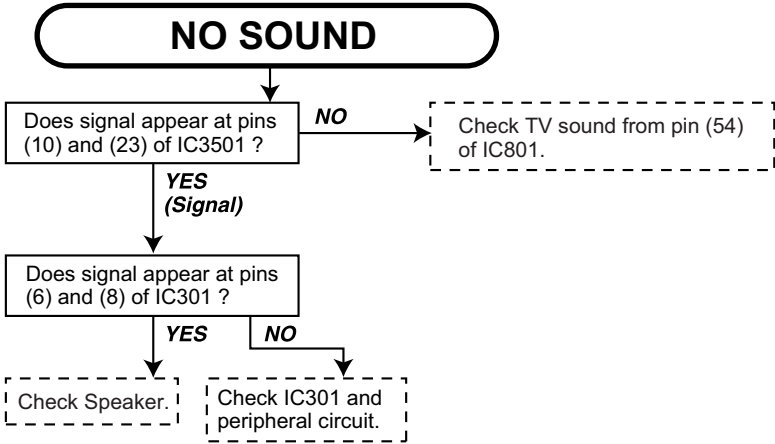

NEITHER VERTICAL NOR HORIZONTAL SYNCHRONIZATION

CIRCUIT TO BE CHECKED:

- Sync. Separator Circuit.

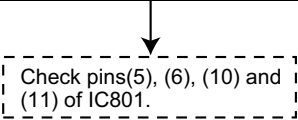

DEFECTIVE VERTICAL AMP. AND VERTICAL LINEARITY

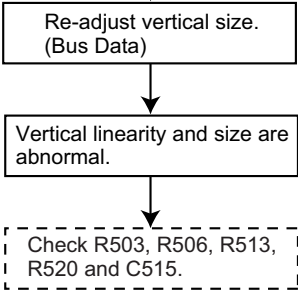

NO VERTICAL SCAN

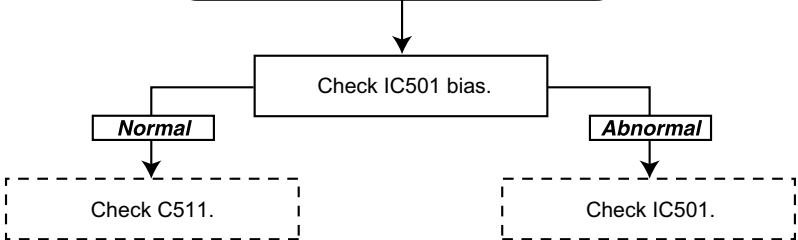

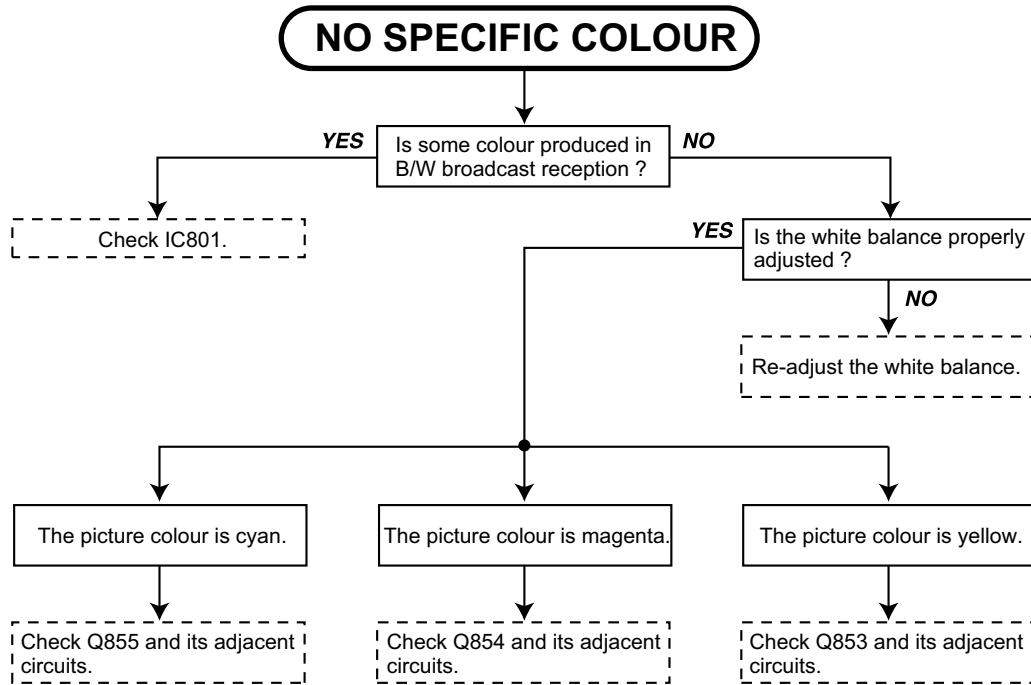

**NO SPECIFICATION COLOUR
"PAL / SECAM"
(NO COLOUR SYNCHRONIZATION)**

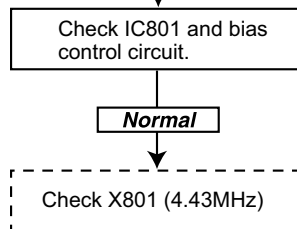

CHAPTER 6. SOLID STATE DEVICE BASE DIAGRAM

[1] SOLID STATE DEVICE BASE DIAGRAM

TOP VIEW

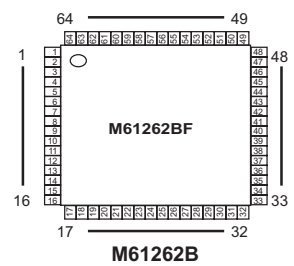
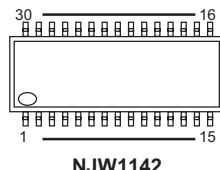
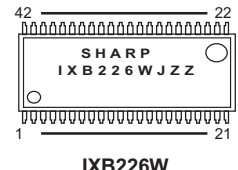
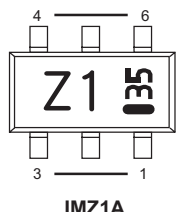
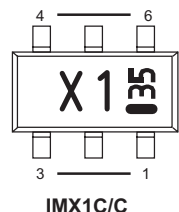
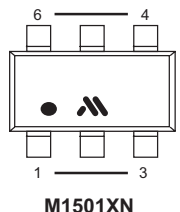
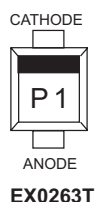
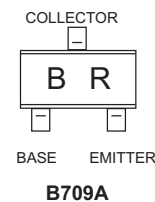
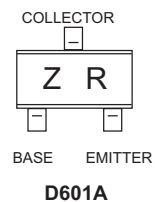
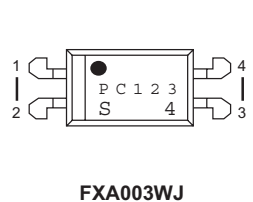
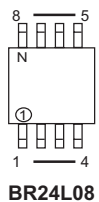

SIDE VIEW

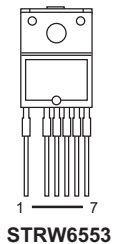
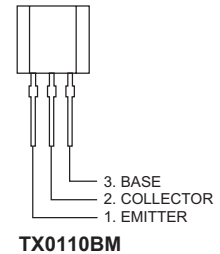
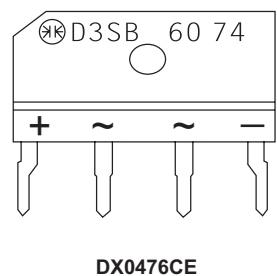
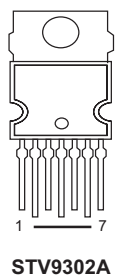
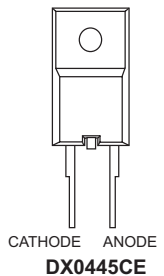
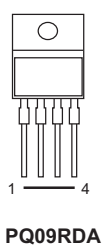
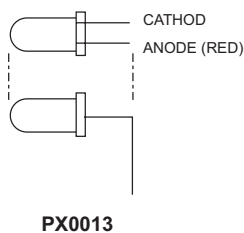
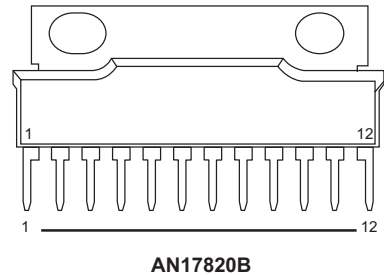
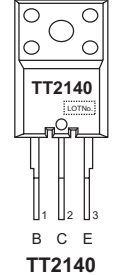
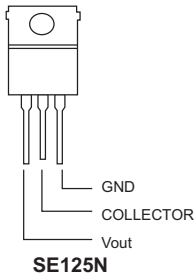
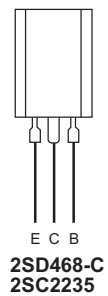
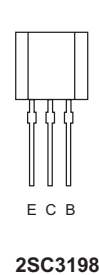

CHAPTER 7. CHASSIS LAYOUT

[1] CHASSIS LAYOUT

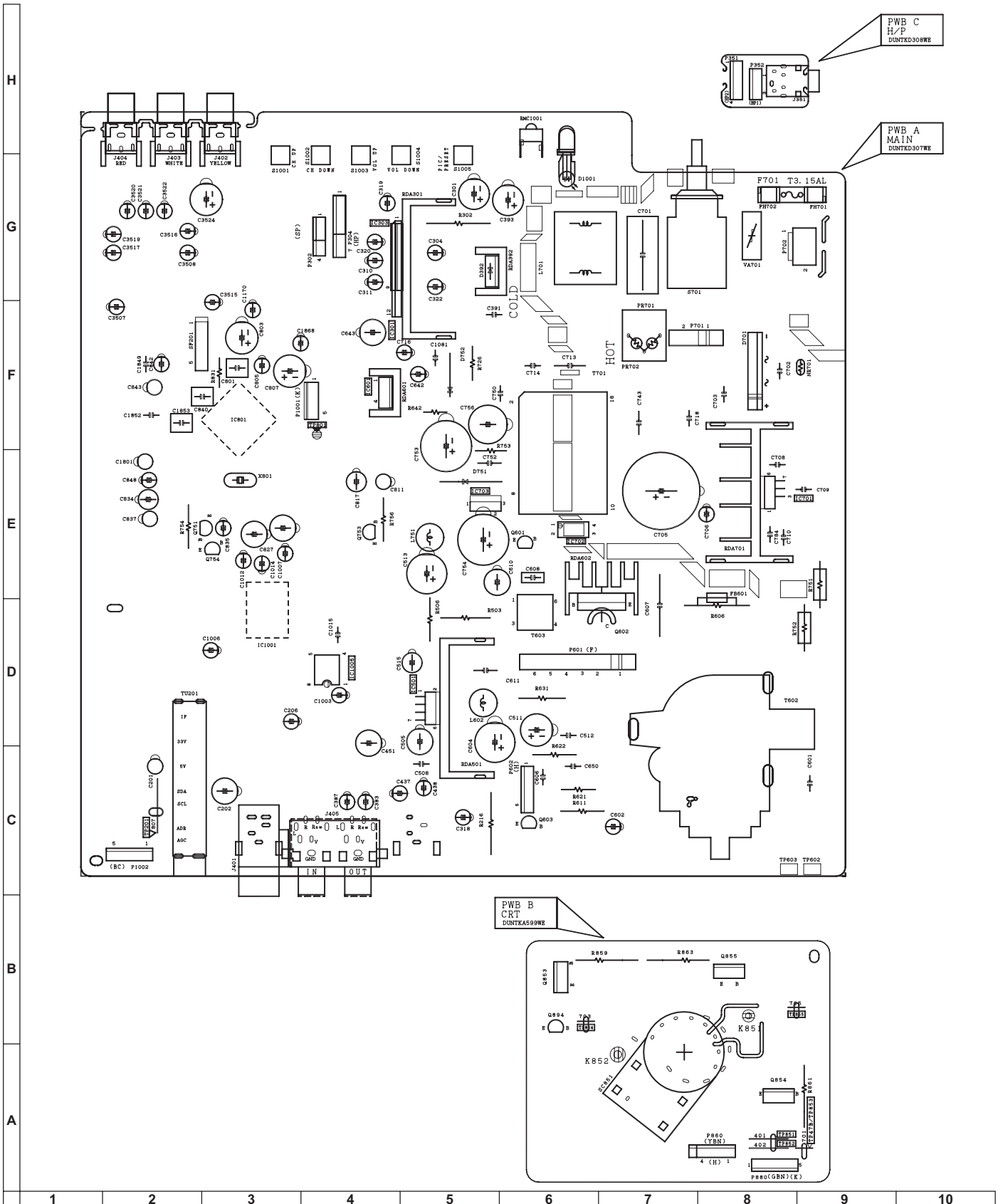

CHAPTER 8. BLOCK DIAGRAM

[1] BLOCK DIAGRAM: CRT UNIT

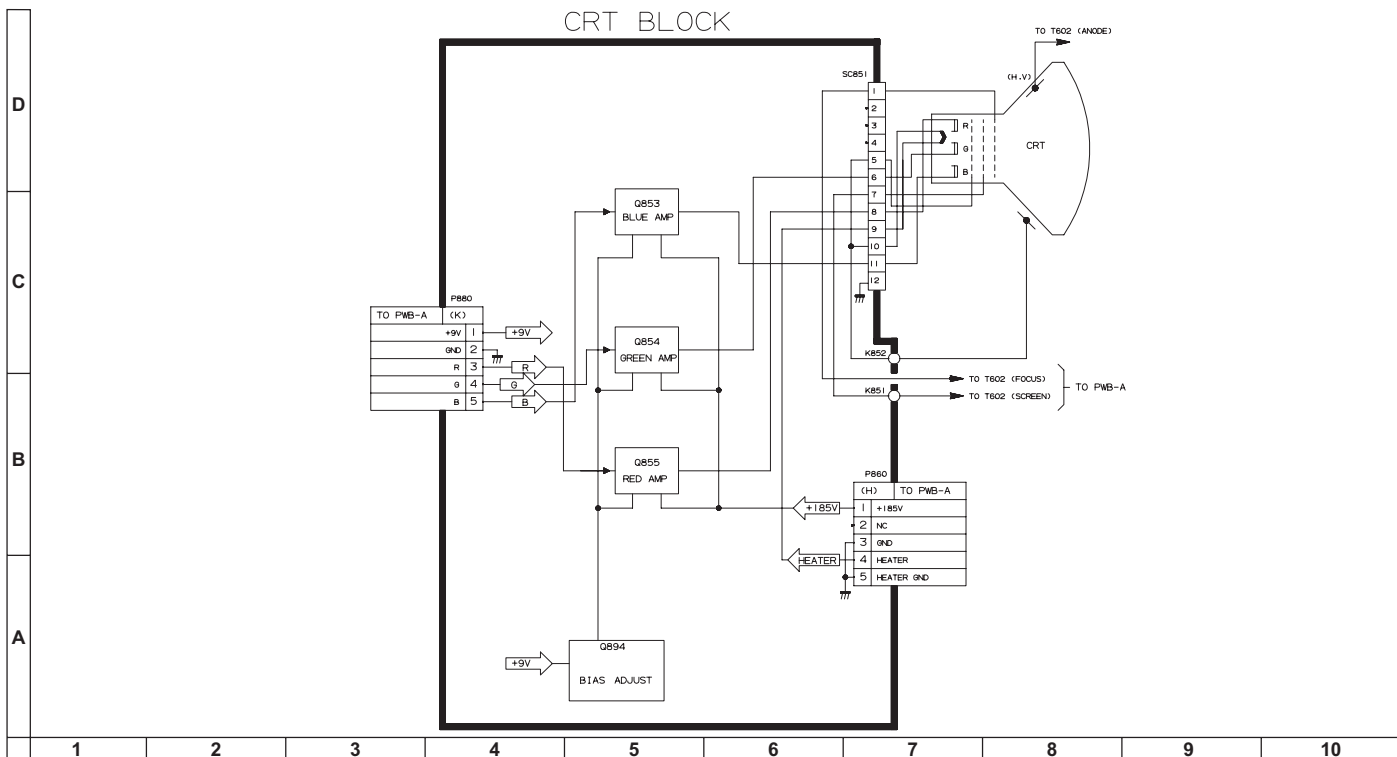

[2] BLOCK DIAGRAM: HEADPHONE UNIT

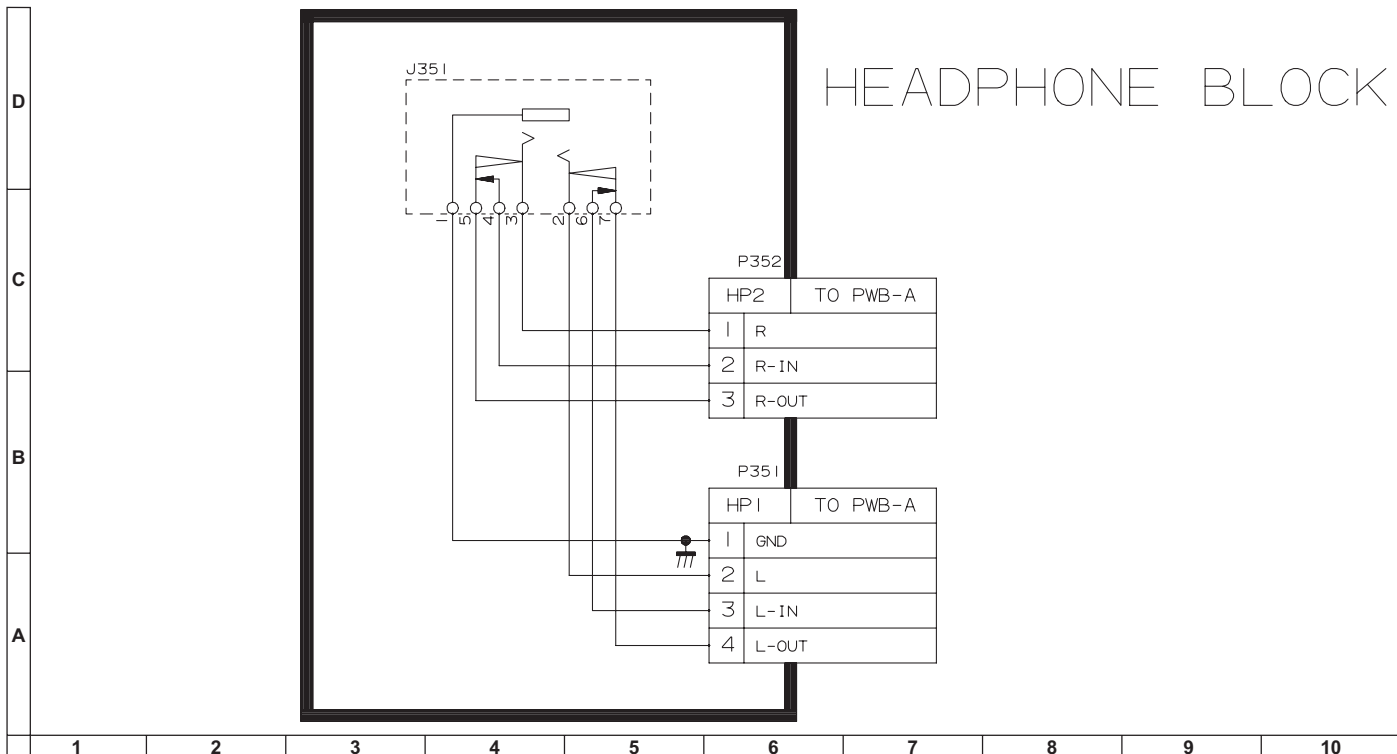

[3] BLOCK DIAGRAM: MAIN UNIT

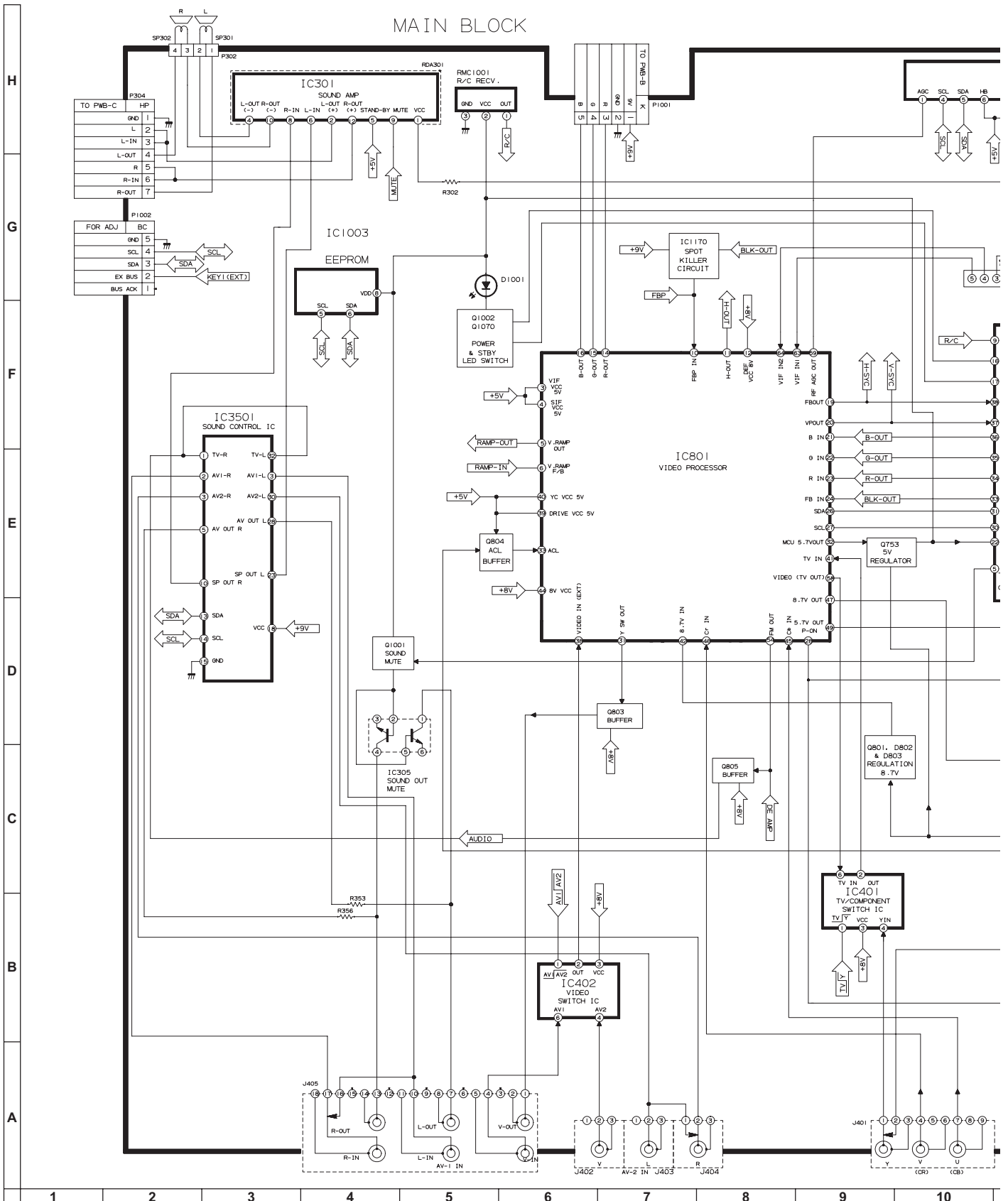

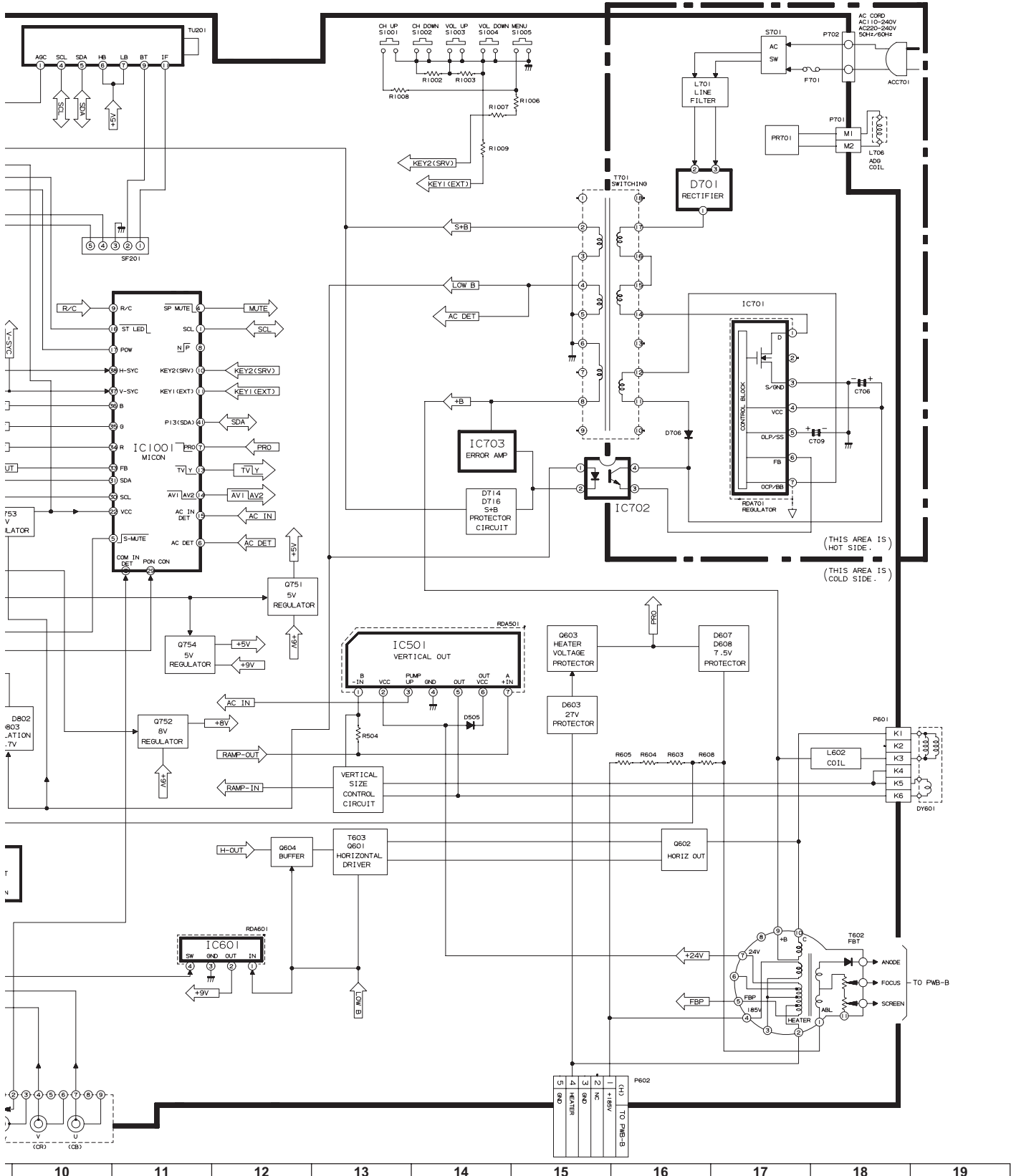



CHAPTER 9. DESCRIPTION OF SCHEMATIC DIAGRAM

[1] DESCRIPTION OF SCHEMATIC DIAGRAM

SAFETY NOTES:

1. DISCONNECT THE AC PLUG FROM THE AC OUTLET BEFORE REPLACING PARTS.
2. SEMICONDUCTOR HEAT SINKS SHOULD BE REGARDED AS POTENTIAL SHOCK HAZARDS WHEN THE CHASSIS IS OPERATING.

IMPORTANT SAFETY NOTICE:

PARTS MARKED WITH "  " () ARE IMPORTANT FOR MAINTAINING THE SAFETY OF THE SET. BE SURE TO REPLACE THESE PARTS WITH SPECIFIED ONES FOR MAINTAINING THE SAFETY AND PERFORMANCE OF THE SET.

SERVICE PRECAUTION:

THE AREA ENCLOSED BY THIS LINE (— — —) IS DIRECTLY CONNECTED WITH AC MAINS VOLTAGE. WHEN SERVICING THE AREA, CONNECT AN ISOLATING TRANSFORMER BETWEEN TV RECEIVER AND AC LINE TO ELIMINATE HAZARD OF ELECTRIC SHOCK.

CAUTION:

This circuit diagram is a standard one, prited circuits may be subject to change for product improvement without prior notice.

NOTES:

1. The unit of resistance "ohm" is omitted. (K = 1000 ohms, M = Mega ohm).
2. All resistors are 1/16 watt, unless otherwise noted.
3. All capacitors are μF , unless otherwise noted. (P = $\mu\mu\text{F}$).

VOLTAGE MEASUREMENT CONDITIONS:

1. Voltages in parenthesis measured with no signal.
2. Voltages without parenthesis measured with 3mV B & W or Colour signal.
3. All the voltages in each point are measured with VTVM.

WAVEFORM MEASUREMENT CONDITIONS:

1. The colour bar generator signal of 1.0V peak applied at pin (41) of IC801.
2. Approximately 4V AGC bias.

CHAPTER 10. WAVEFORM

[1] WAVEFORMS

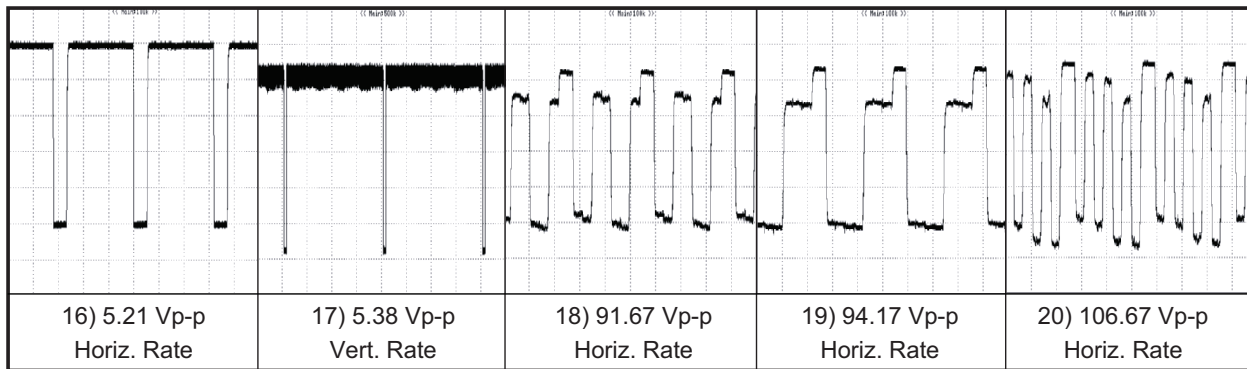
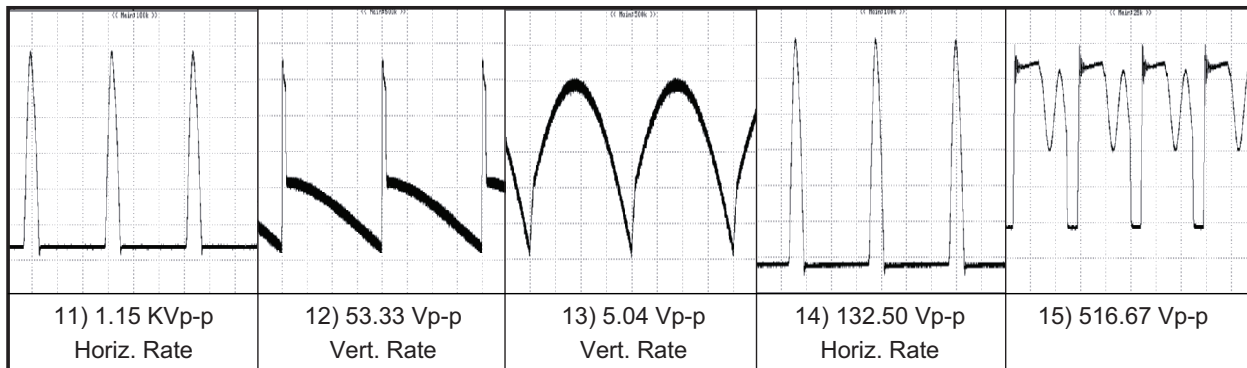
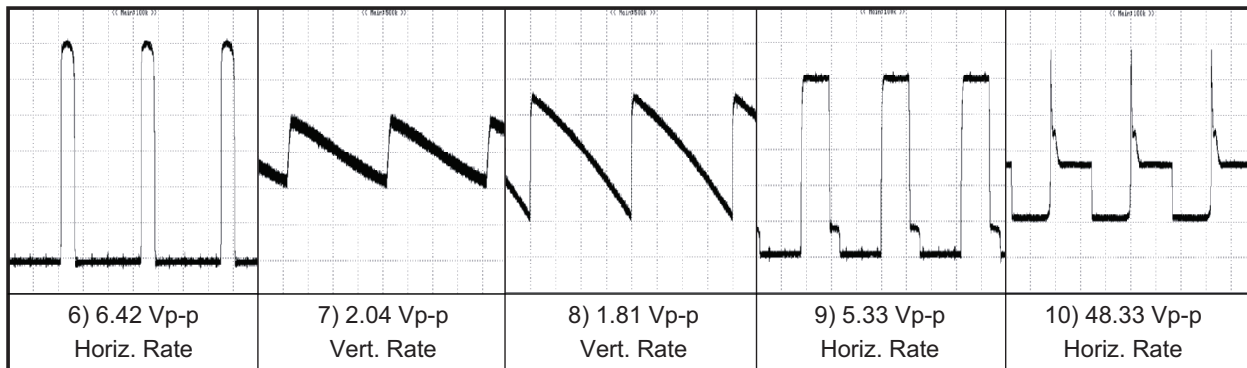
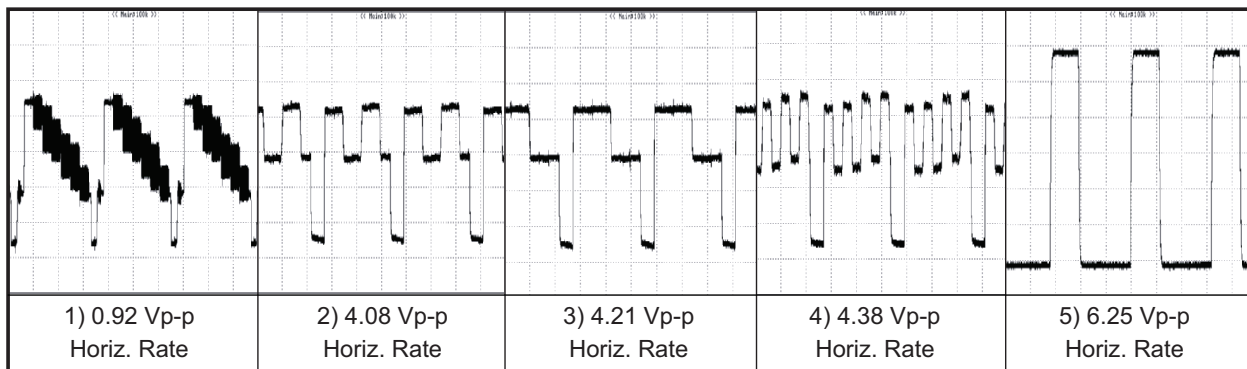

CHAPTER 11. SCHEMATIC DIAGRAM

[1] SCHEMATIC DIAGRAM: MAIN UNIT

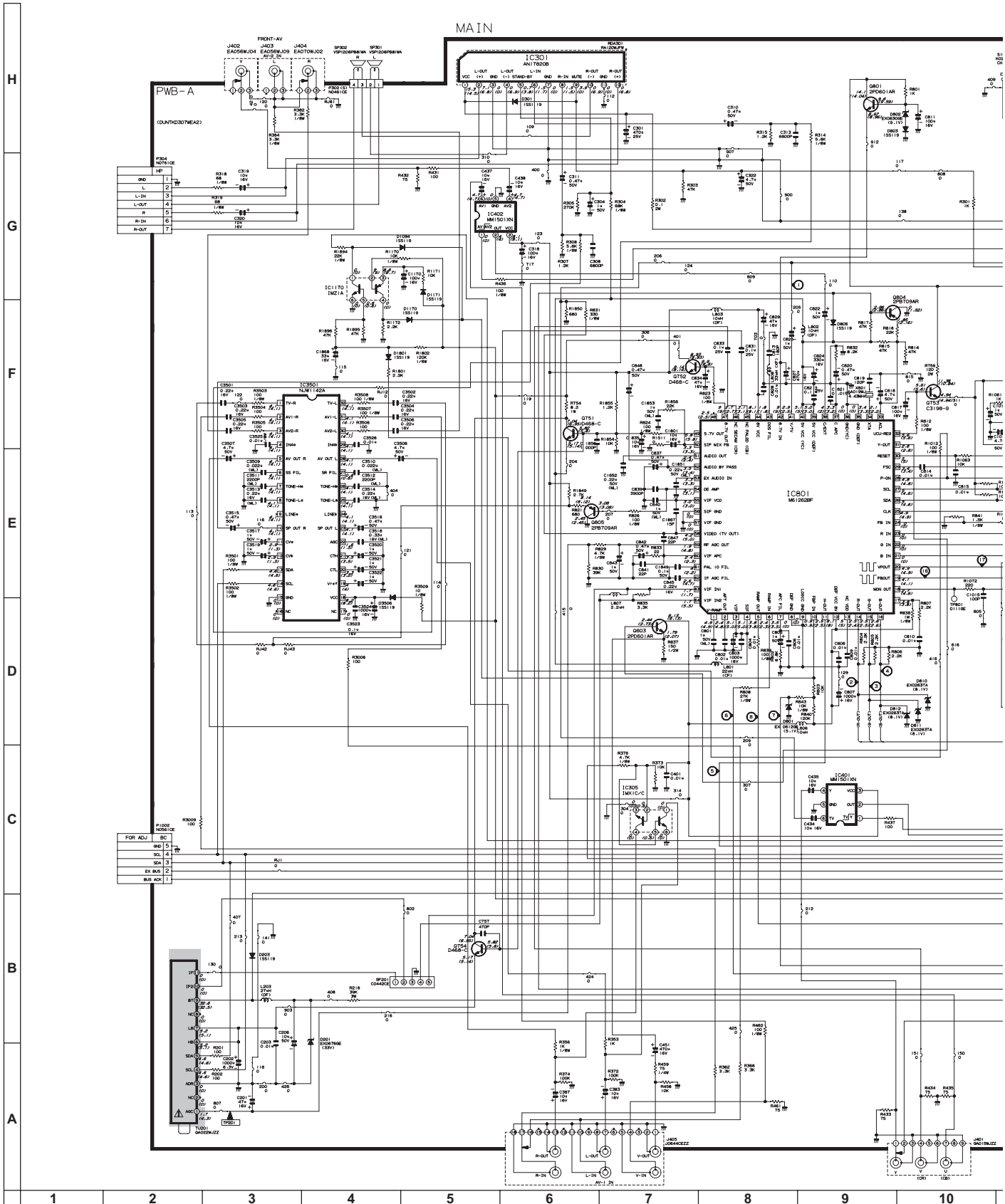

NOTE 1: THE UNIT OF RESISTANCE "OHM" IS OMITTED (10K=1000 OHMS, 100K=10000 OHMS, ETC.)
 2: ALL RESISTORS ARE 1/8W WATT UNLESS OTHERWISE NOTED.
 3: UNIT OF ALL CAPACITORS ARE P WITH PREFIX SYMBOL (e.g. P, ETC.).

▲ AND SHADED COMPONENTS = SAFETY RELATED PARTS.
 ▲ MARK = X-RAY RELATED PARTS.

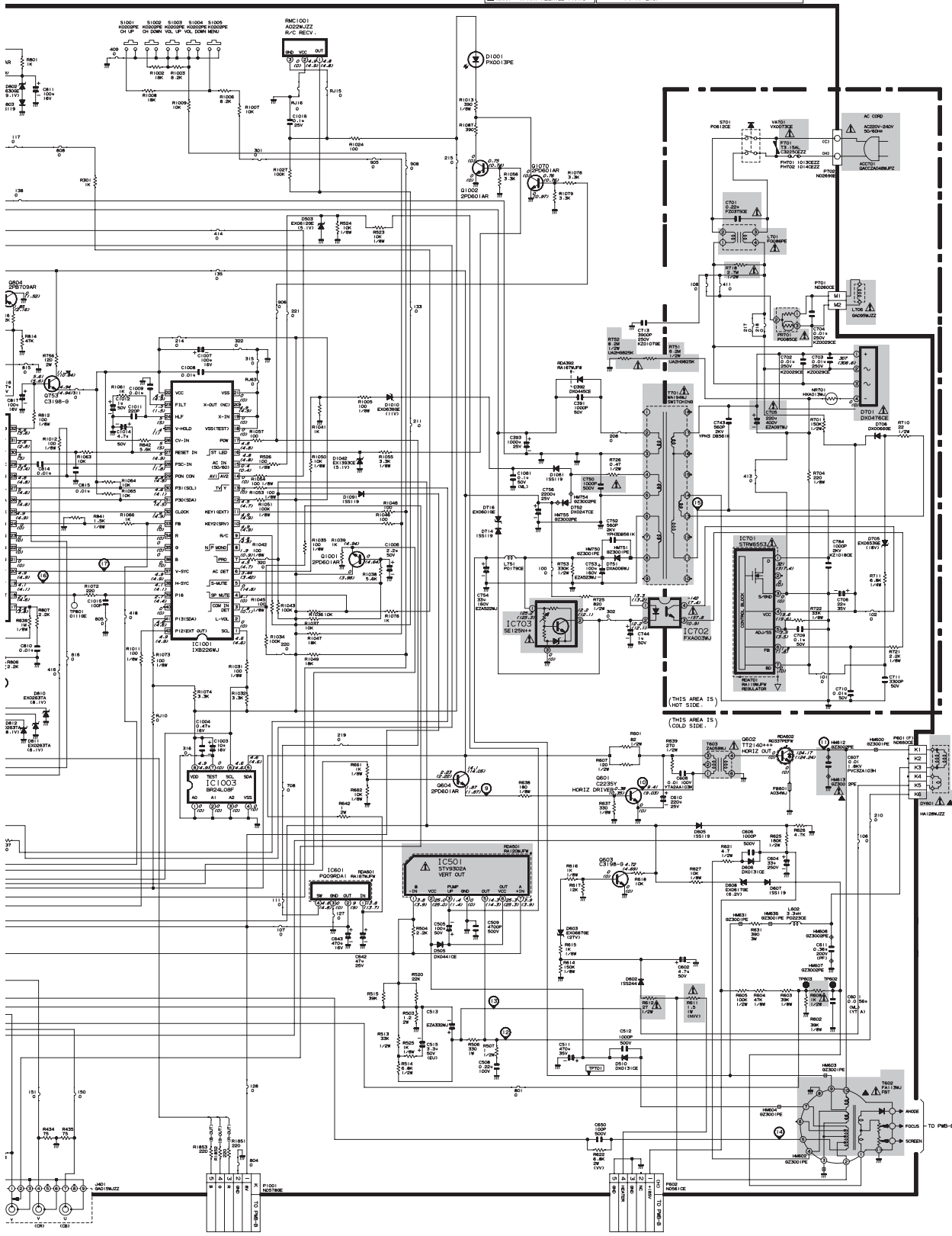

10	11	12	13	14	15	16	17	18	19
----	----	----	----	----	----	----	----	----	----

[2] SCHEMATIC DIAGRAM: CRT UNIT

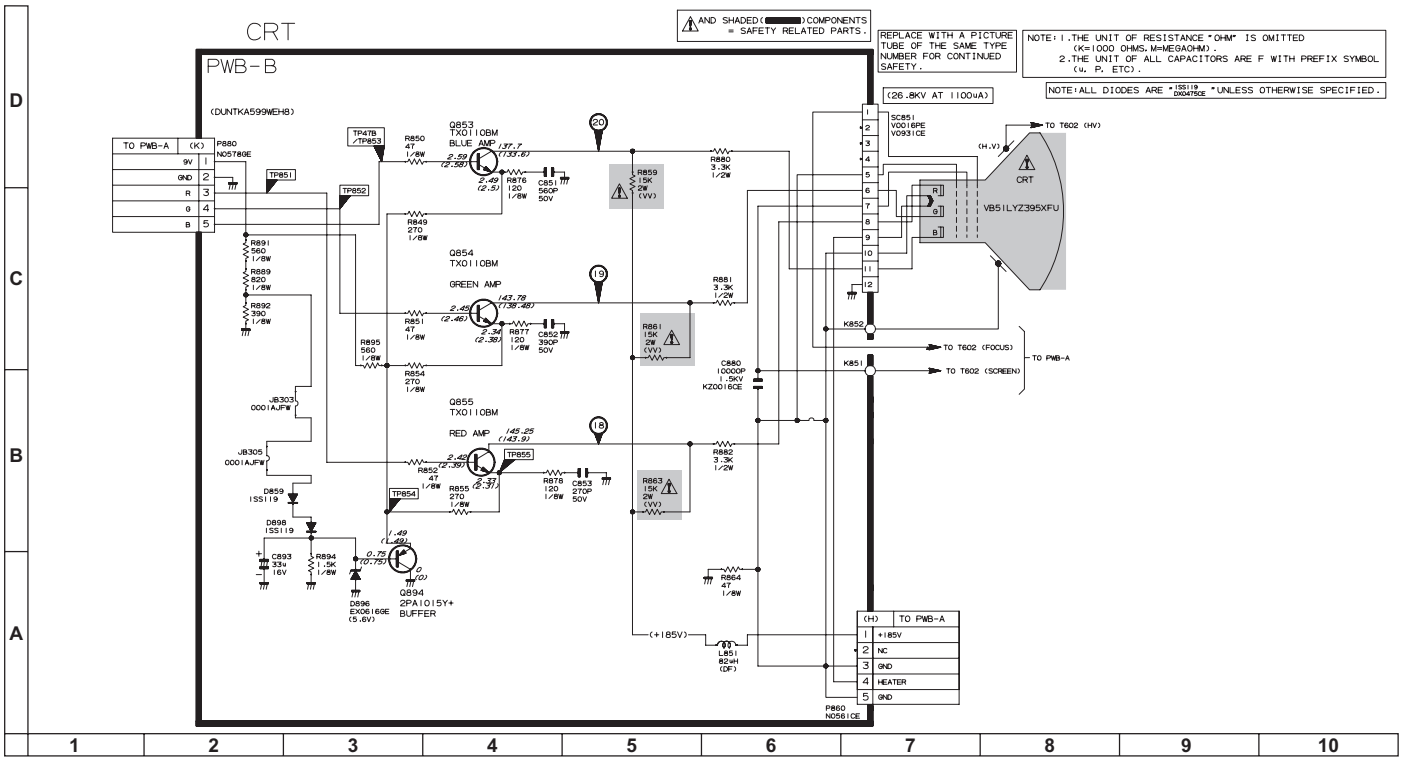

[3] SCHEMATIC DIAGRAM: HEADPHONE UNIT

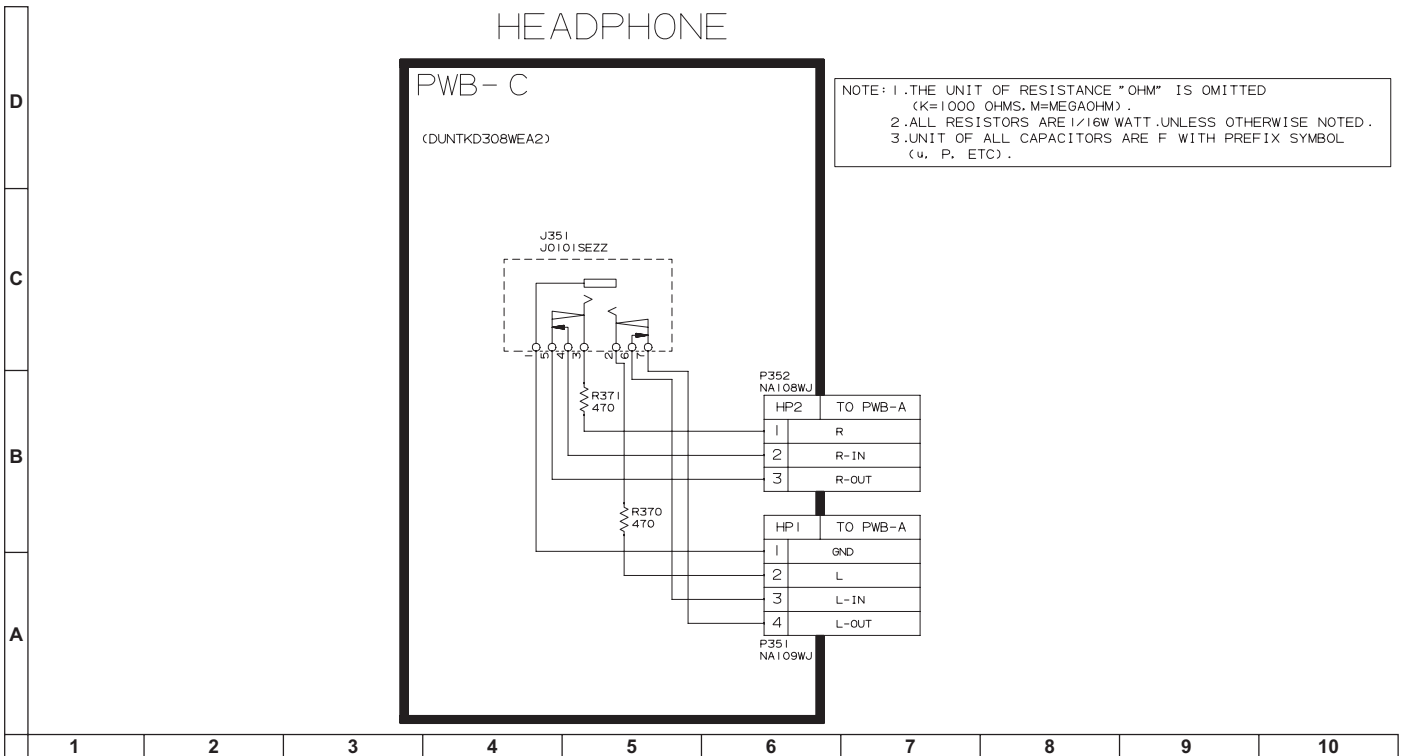

CHAPTER 12. PRINTED WIRING BOARD ASSEMBLIES

[1] PWB-B: CRT UNIT

1. CRT UNIT (Component Side)

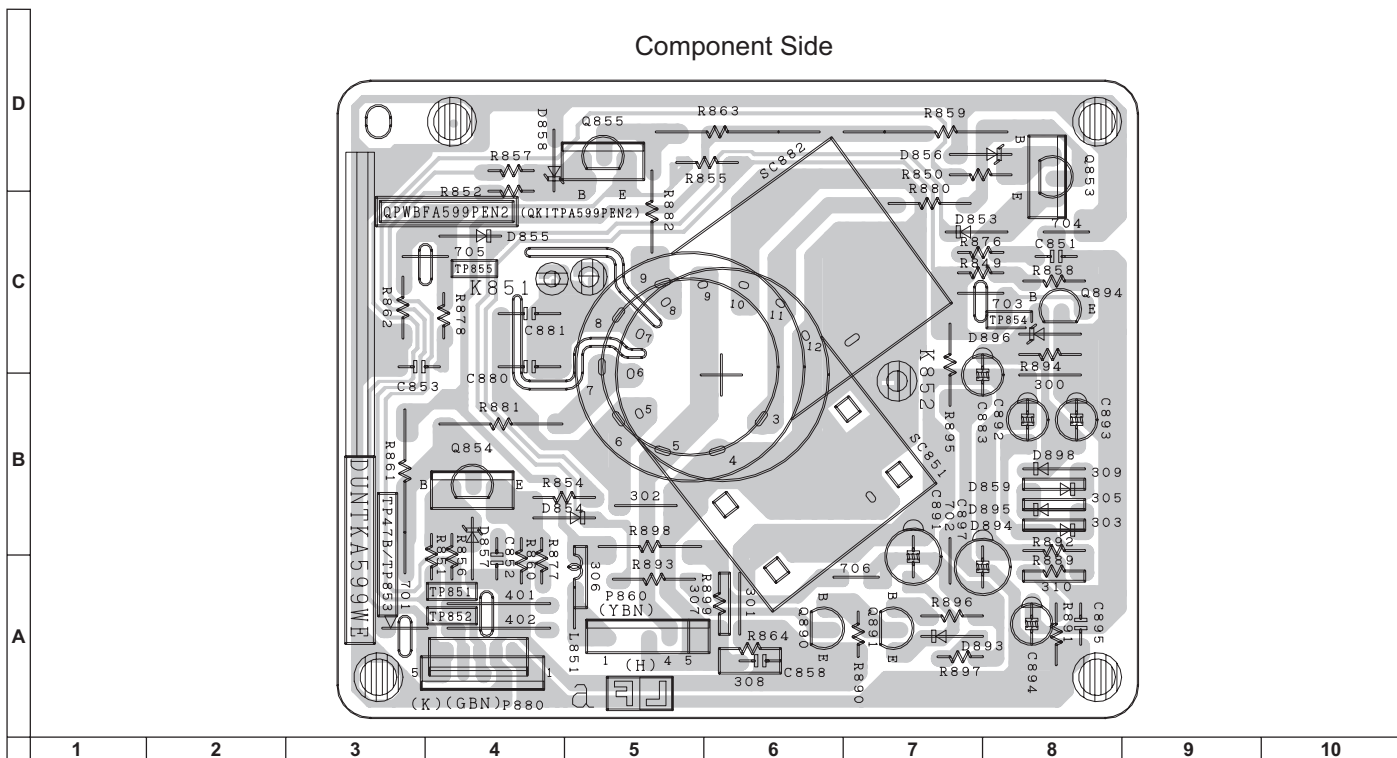

[2] PWB-C: HEADPHONE UNIT

1. HEADPHONE UNIT (Component Side) (Chip Parts Side)

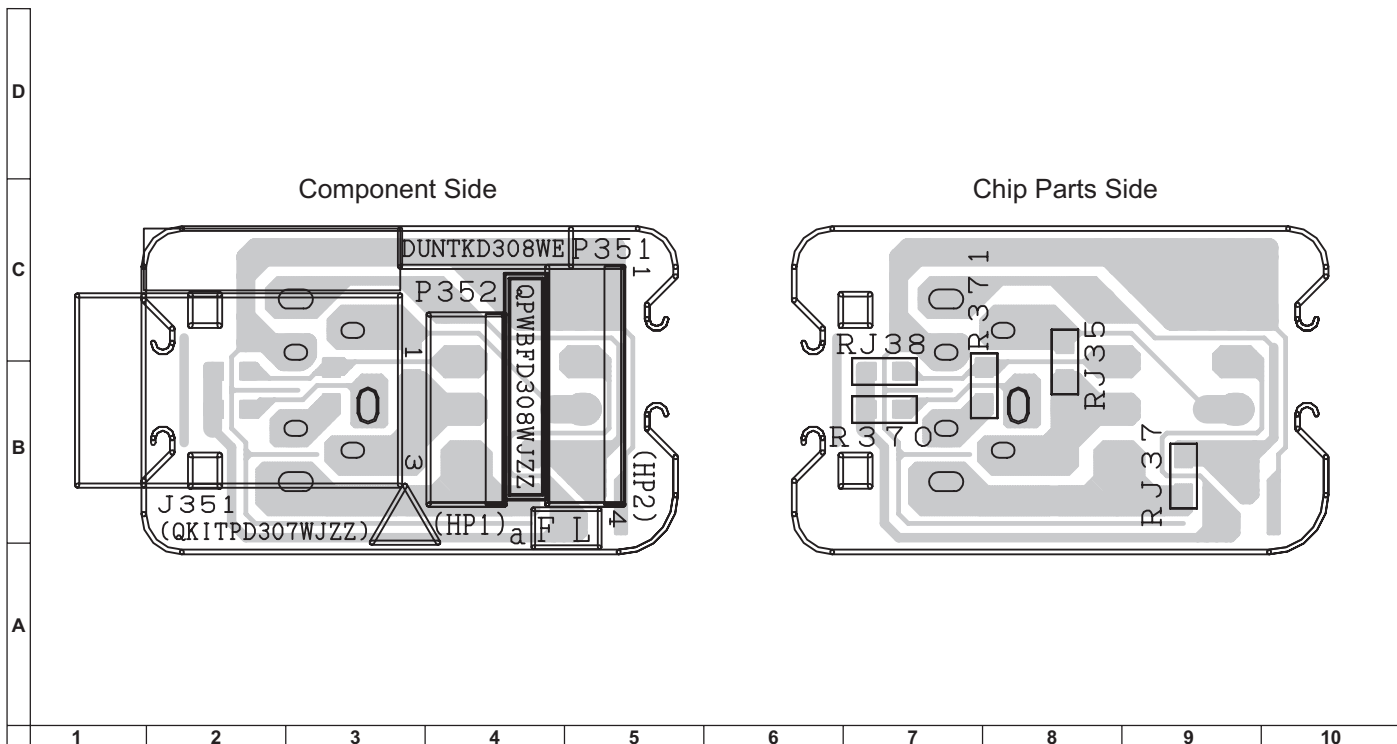

[3] PWB-A: MAIN UNIT

1. MAIN UNIT (Component Side)

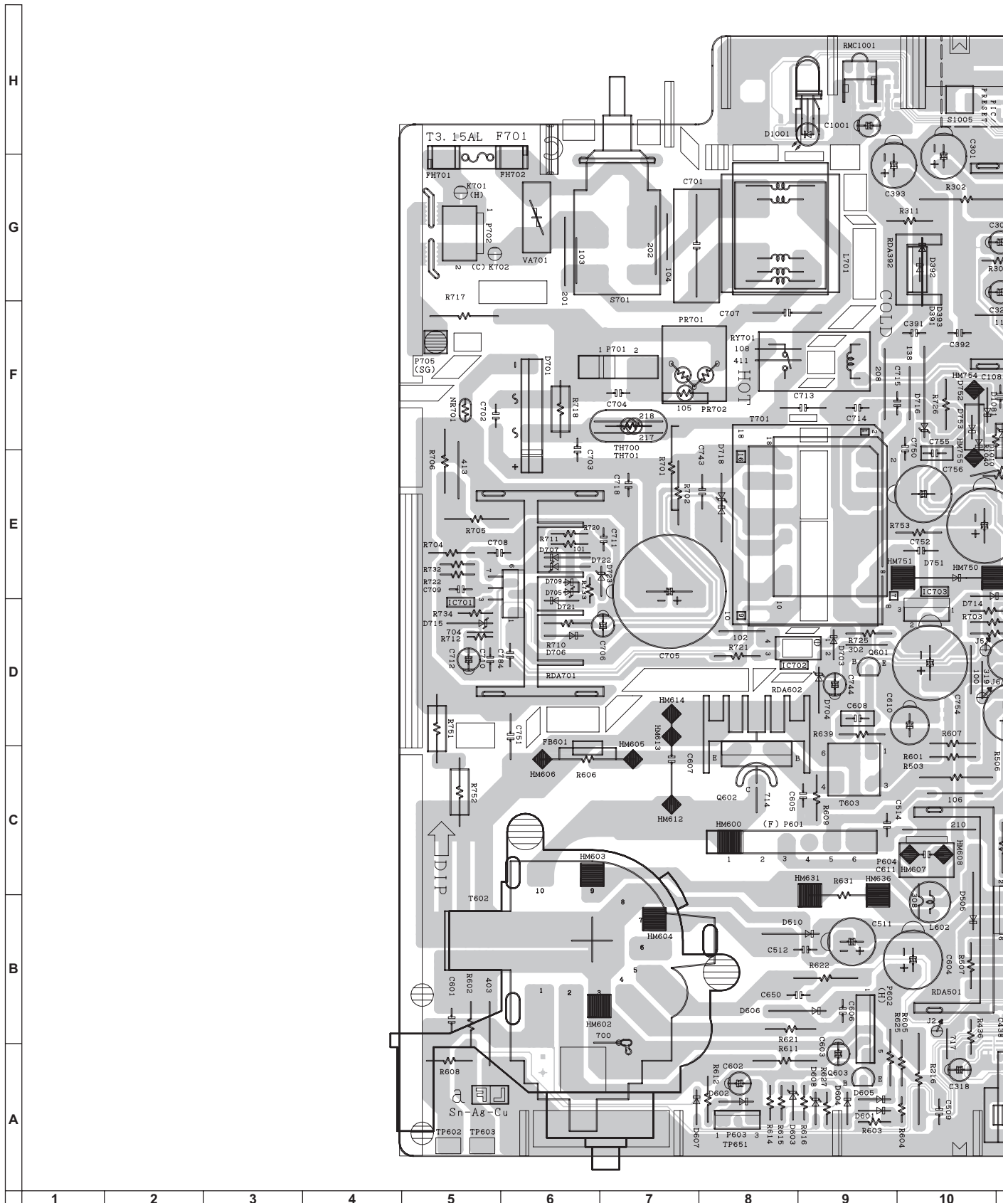

2. MAIN UNIT (Chip Parts Side)

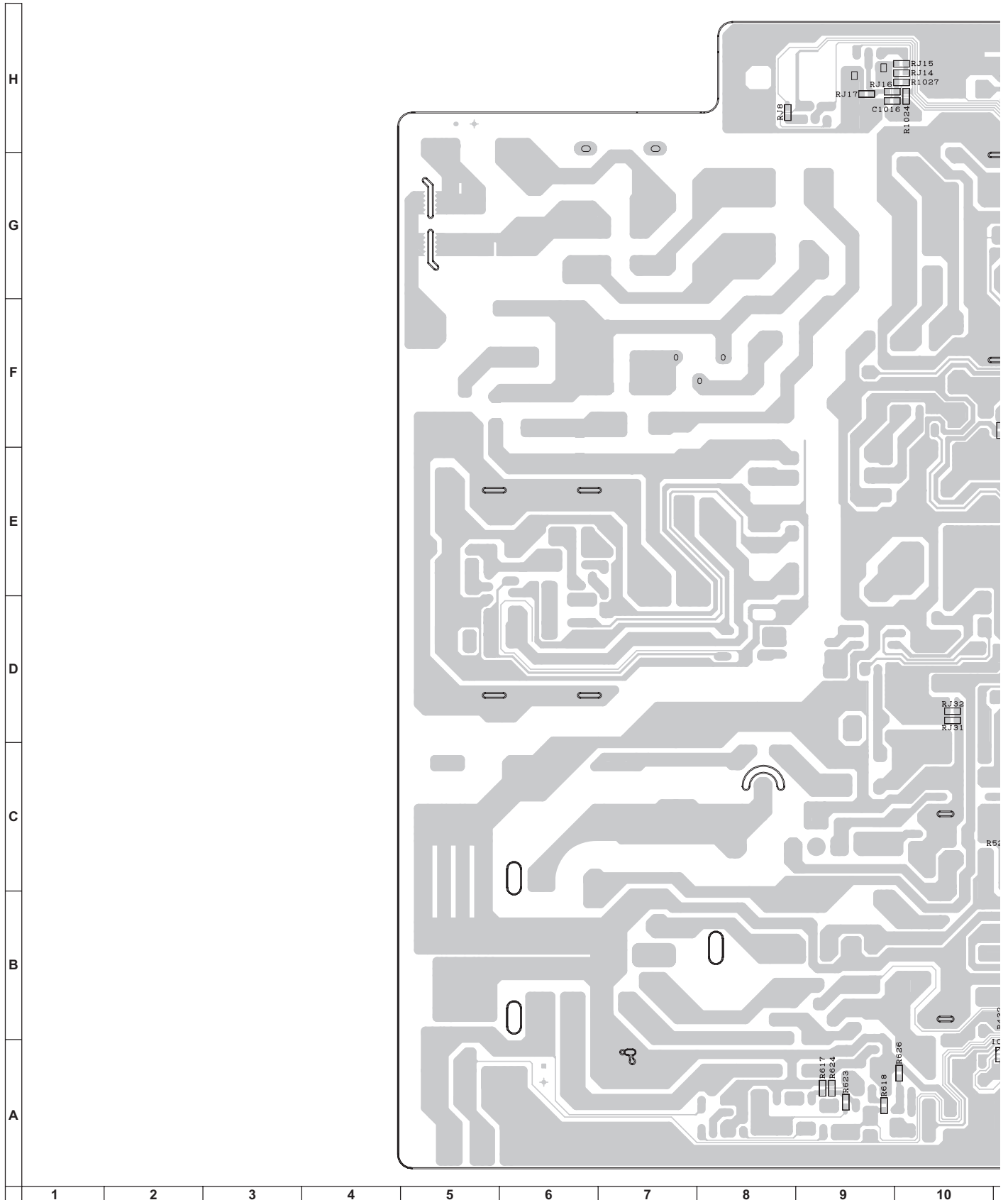

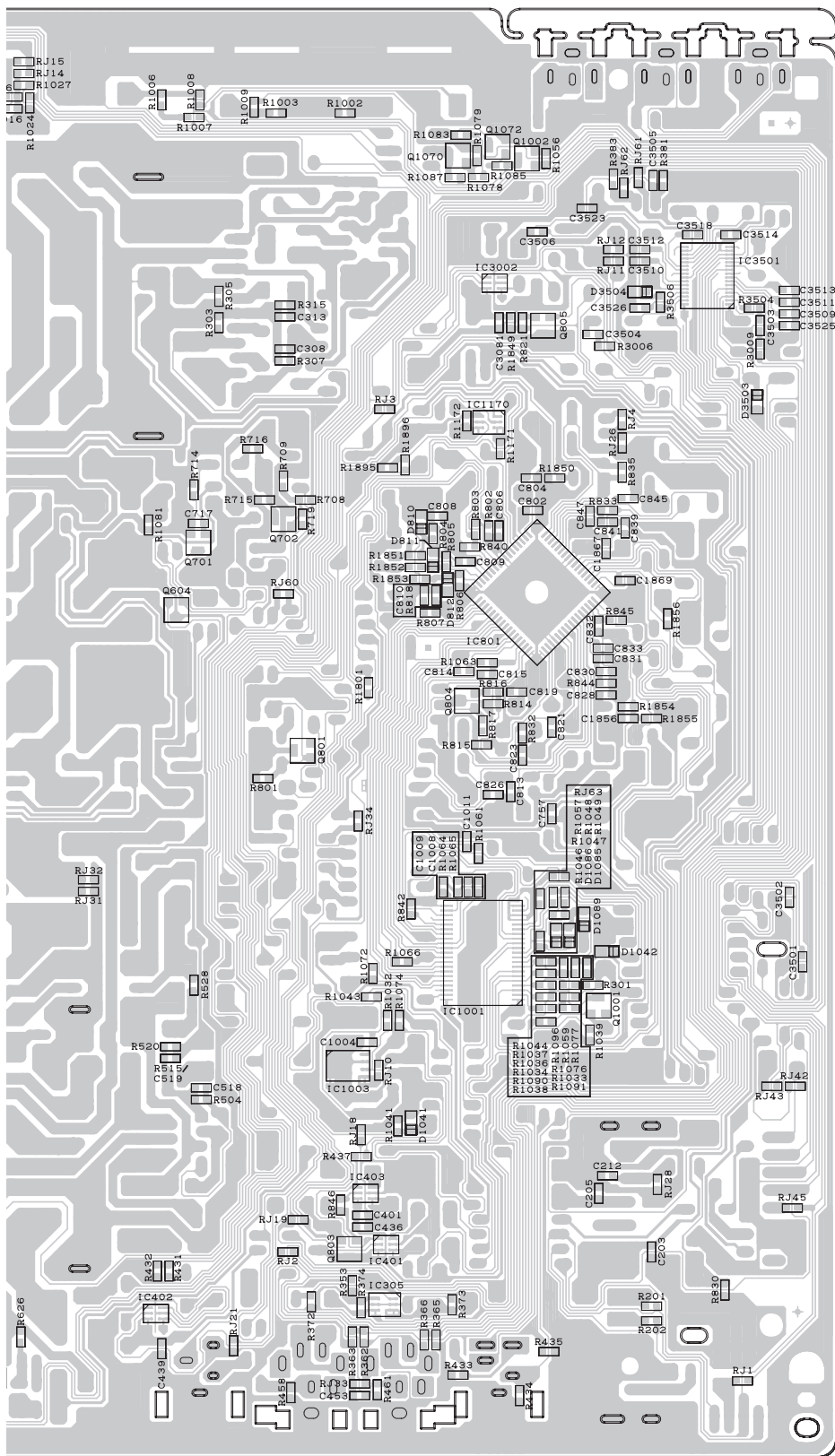

10	11	12	13	14	15	16	17	18	19
----	----	----	----	----	----	----	----	----	----

SHARP PARTS GUIDE

No. S75L821JFG1RU

MODEL **21J-FG1RU**

CONTENTS

- | | |
|--|--------------------------|
| [1] PICTURE TUBE | [6] MISCELLANEOUS PARTS |
| [2] PRINTED WIRING BOARD
ASSEMBLIES | [7] CABINET PARTS |
| [3] MAIN UNIT | [8] SUPPLIED ACCESSORIES |
| [4] CRT UNIT | [9] PACKING PARTS |
| [5] HEADPHONE UNIT | |

Parts marked with "△" are important for maintaining the safety of the set. Be sure to replace these parts with specified ones for

NO.	PARTS CODE	PRICE RANK	NEW MARK	PART RANK	DESCRIPTION	
[1] PICTURE TUBE						
	VB51LYZ395XFU			R	Picture Tube	
△	L706	RCILGA095WJZZ	AM		R	Degaussing Coil
△	DY601	RCILHA128WJZZ			R	Deflection Yoke
		QEARCA012WJZZ	AG		R	Corting Earth
		PMAGF3046CEZZ	AF		R	Purity Mag.
		PSPAG0003PEZZ	AD		R	Rubber Wedge
		LHLDW0003PEKZ	AB		R	Wire Holder
		LHLDW1075PEKZ	AC		R	Wire Holder
[2] PRINTED WIRING BOARD ASSEMBLIES						
					(NOT REPLACEMENT ITEM)	
		DUNTKD307WEA2	-	-	MAIN Unit	
		DUNTKA599WEH8	-	-	CRT Unit	
		DUNTKD308WEA2	-	-	HEADPHONE Unit	
[3] MAIN UNIT						
					PWB-A: DUNTKD307WEA2	
△	TU201	RTUNQA022WJZZ	AT		R	Tuner
	IC301	VHIAN17820B-1	AL		R	Audio IC, AN17820B
	IC305	VSIMX1C/C//1Y	AC		R	Transistor, IMX1C/C
	IC401	VHIMM1501XN-1Y	AE		R	MM1501XNRE
	IC402	VHIMM1501XN-1Y	AE		R	MM1501XNRE
△	IC501	VHISTV9302A-1	AH		R	VertiCal IC, STV9302A
	IC601	VHIPQ09RDA1-1	AF		R	PQ090RDA1SZ
△	IC701	VHISTRW6553-1			R	Power IC, STRW6553
△	IC702	RH-FXA003WJZZ	AD		R	Power IC,
△	IC703	VHISE125N++-F	AG		R	Hybrid IC, SE125N
	IC801	VHIM61262BF1EQ	AZ		R	1 Chip IC, M61262BFP
	IC1001	RH-IXB226WJZZ			R	Micon, M37160MAH
	IC1003	VHIBR24L08F-1Y	AE		R	EEPROM IC, BR24L08F
	IC1170	VSIMZ1A///-1Y	AC		R	Transistor, IMZ1A
	IC3501	VHINJW1142A-1Y	AM		R	S-Control IC, NJW1142A
	Q601	VS2SC2235Y/1E+	AE		R	Transistor, 2SC2235Y1E
	Q602	VS2T2140+++F	AG		R	Transistor, TT2140-F
	Q603	VS2SC3198-G-1+	AA		R	Transistor, 2SC3198-G
	Q604	VS2PD601AR/-1Y	AB		R	Transistor, 2PD601AR
	Q751	VS2SD468-C/-1+	AD		R	Transistor, 2SD468-C
	Q752	VS2SD468-C/-1+	AD		R	Transistor, 2SD468-C
	Q753	VS2SC3198-G-1+	AA		R	Transistor, 2SC3198-G
	Q754	VS2SD468-C/-1+	AD		R	Transistor, 2SD468-C
	Q801	VS2PD601AR/-1Y	AB		R	Transistor, 2PD601AR
	Q803	VS2PD601AR/-1Y	AB		R	Transistor, 2PD601AR
	Q804	VS2PB709AR/-1Y	AB		R	Transistor, 2PB709AR
	Q805	VS2PB709AR/-1Y	AB		R	Transistor, 2PB709AR
	Q1001	VS2PD601AR/-1Y	AB		R	Transistor, 2PD601AR
	Q1002	VS2PD601AR/-1Y	AB		R	Transistor, 2PD601AR
	Q1070	VS2PD601AR/-1Y	AB		R	Transistor, 2PD601AR
	D201	RH-EX0676GEZZY	AA		R	Zener Diode, 32.5V
	D203	VHD1SS119//1Y	AA		R	Diode, 1SS119
	D301	VHD1SS119//1Y	AA		R	Diode, 1SS119
	D392	RH-DX0445CEZZ	AL		R	Diode
	D503	RH-EX0612GEZZY	AB		R	Zener Diode, 5.2V
	D505	RH-DX0441CEZZY	AC		R	Diode
	D510	RH-DX0131CEZZY	AC		R	Diode
	D602	VHD1SS244//1Y	AB		R	Diode, 1SS244
	D603	RH-EX0667GEZZY	AA		R	Zener Diode, 26.26V
	D605	VHD1SS119//1Y	AA		R	Diode, 1SS119
	D606	RH-DX0131CEZZY	AC		R	Diode
	D607	VHD1SS119//1Y	AA		R	Diode, 1SS119
	D608	RH-EX0617GEZZY	AA		R	Zener Diode, 6V
△	D701	RH-DX0476CEZZ	AG		R	Diode
	D705	RH-EX0653GEZZY	AA		R	Zener Diode, 18.33V
	D706	RH-DX0066GEZZY	AC		R	Diode
	D714	VHD1SS119//1Y	AA		R	Diode, 1SS119
	D716	RH-EX0601GEZZY	AA		R	Zener Diode, 3.7V
	D751	RH-DXA006WJZZ	AD		R	Diode
	D752	RH-DX0247CEZZ	AE		R	Diode
	D801	RH-EX0612GEZZY	AB		R	Zener Diode, 5.2V
	D802	RH-EX0630GEZZY	AA		R	Zener Diode, 9V
	D803	VHD1SS119//1Y	AA		R	Diode, 1SS119
	D806	VHD1SS119//1Y	AA		R	Diode, 1SS119
	D810	RH-EX0263TAZZY	AC		R	Zener Diode, 8.36V
	D811	RH-EX0263TAZZY	AC		R	Zener Diode, 8.36V
	D812	RH-EX0263TAZZY	AC		R	Zener Diode, 8.36V
	D1001	RH-PX0013PEZZ	AC		R	LED
	D1010	RH-EX0636GEZZY	AC		R	Zener Diode, 10.7V
	D1042	RH-EX1393CEZZY	AB		R	Zener Diode, 5.2V
	D1081	VHD1SS119//1Y	AA		R	Diode, 1SS119
	D1091	VHD1SS119//1Y	AA		R	Diode, 1SS119
	D1094	VHD1SS119//1Y	AA		R	Diode, 1SS119
	D1170	VHD1SS119//1Y	AA		R	Diode, 1SS119
	D1171	VHD1SS119//1Y	AA		R	Diode, 1SS119
	D1801	VHD1SS119//1Y	AA		R	Diode, 1SS119
	D3506	VHD1SS119//1Y	AA		R	Diode, 1SS119

NO.	PARTS CODE	PRICE RANK	NEW MARK	PART RANK	DESCRIPTION
[3] MAIN UNIT					
△	VA701	RH-VX0073CEZZ	AD	R	Varistor
△	PR701	RMPTP0085CEZZ	AL	R	Packaged Circuit
	X801	RCRCAA019WJZZ	AF	R	Crystal, 4.433619MHz
	L203	VP-DF270K0000Y	AB	R	Peaking 27μH
	L602	RCILP0223CEZZ+	AD	R	Coil
△	L701	RCILF0086PEN1	AF	R	Coil
	L751	RCILP0179CEZZ+	AD	R	Coil
	L801	VP-CF220K0000Y	AB	R	Peaking 22μH
	L802	VP-DF100K0000Y	AB	R	Peaking 10μH
	L803	VP-DF100K0000Y	AB	R	Peaking 10μH
	L806	VP-DF100K0000Y	AB	R	Peaking 10μH
	L807	VP-XF2R2K0000Y	AB	R	Peaking 2.2μH
	L808	VP-XF330K0000Y	AB	R	Peaking 33μH
	SF201	RFILC0442CEZZ	AL	R	Filter
△	T602	RTRNFA113WJZZ		R	H-Volt Transformer
△	T603	RTRNZA058WJZZ	AD	R	Transformer
△	T701	RTRNWA194WJZZ		R	Transformer
	C201	VCEA9M1CW476M+	AB	R	47 16V Electrolytic
	C202	VCEA0A0JW108M+	AC	R	1000 6.3V Electrolytic
	C203	VCKYCY1HF103ZY	AA	R	0.01 50V Ceramic
	C206	VCEA0A1HW106M+	AB	R	10 50V Electrolytic
	C301	VCEA0A1EW477M+	AD	R	470 25V Electrolytic
	C304	VCEA0A1HW105M+	AB	R	1 50V Electrolytic
	C308	VCKYCY1HB682KY	AA	R	6800p 50V Ceramic
	C310	VCEA0A1HW474M+	AB	R	0.47 50V Electrolytic
	C311	VCEA0A1HW474M+	AB	R	0.47 50V Electrolytic
	C313	VCKYCY1HB682KY	AA	R	6800p 50V Ceramic
	C318	VCEA0A1CW107M+	AC	R	100 16V Electrolytic
	C319	VCEA0A1CW106M+	AB	R	10 16V Electrolytic
	C320	VCEA0A1CW106M+	AB	R	10 16V Electrolytic
	C322	VCEA0A1HW475M+	AB	R	4.7 50V Electrolytic
	C383	VCEA0A1CW106M+	AB	R	10 16V Electrolytic
	C387	VCEA0A1CW106M+	AB	R	10 16V Electrolytic
	C391	VCKYPA1HB102K+	AA	R	1000p 50V Ceramic
	C393	VCEA0A1EW108M+	AD	R	1000 25V Electrolytic
	C401	VCKYCY1HF103ZY	AA	R	0.01 50V Ceramic
	C434	VCEA0A1CW106M+	AB	R	10 16V Electrolytic
	C435	VCE9GA1CW106M+	AB	R	10 16V Electrolytic (N.P)
	C437	VCEA0A1CW106M+	AB	R	10 16V Electrolytic
	C438	VCEA0A1CW106M+	AB	R	10 16V Electrolytic
	C451	VCEA0A1CW477M+	AC	R	470 16V Electrolytic
	C505	VCEA0A1HW107M+	AB	R	100 50V Electrolytic
	C508	VCFYAA2AA224J+	AD	R	0.22 100V Metalized Polypro Film
	C509	VCKYPA2HB472K+	AB	R	4700p 500V Ceramic
	C511	VCEA0A1VW477M+	AB	R	470 35V Electrolytic
	C512	VCKYPA2HB102K+	AA	R	1000p 500V Ceramic
	C513	RC-EZA332WJZZ+	AD	R	
	C515	VCEACA1HC335J+	AC	R	3.3 50V Electrolytic
	C601	VCQYTA1HM563J+	AB	R	0.056 50V Mylar
	C602	VCEA0A1HW475M+	AB	R	4.7 50V Electrolytic
	C604	VCEA0A2EW336M+	AD	R	33 250V Electrolytic
	C606	VCKYPA2HB102K+	AA	R	1000p 500V Ceramic
△	C607	VCFPVC3ZA103H	AD	R	0.01 1800V Metalized Polypro Film
	C608	VCQYTA2AA103K+	AC	R	0.01 100V Mylar
	C610	VCEA0A1EW227M+	AB	R	220 25V Electrolytic
	C611	VCFPVC2DB364J		R	0.36 200V Metalized Polypro Film
	C642	VCEA0A1EW476M+	AB	R	47 25V Electrolytic
	C643	VCEA0A1CW477M+	AC	R	470 16V Electrolytic
	C650	VCKYPA2HB101K+	AB	R	100p 500V Ceramic
△	C701	RC-FZ037SCEZZ	AD	R	0.22 275V Metalized Polypro Film
	C702	RC-KZ0029CEZZ+	AC	R	0.01 250V Ceramic
	C703	RC-KZ0029CEZZ+	AC	R	0.01 250V Ceramic
	C704	RC-KZ0029CEZZ+	AC	R	0.01 250V Ceramic
△	C705	RC-EZA097WJZZ	AM	R	220 400V Electrolytic
	C706	VCEA0A1VW226M+	AB	R	22 35V Electrolytic
	C709	VCFYFA1HA104J+	AA	R	0.1 50V Metalized Polypro Film
	C710	VCQYTA1HM103J+	AB	R	0.01 50V Mylar
	C711	VCKYPA1HB332K+	AB	R	3300p 50V Ceramic
	C713	RC-KZ0107GEZZ	AE	R	3900p 250V Ceramic
	C743	VCKYPH3DB561K	AC	R	560p 2000V Ceramic
	C744	VCEA0A1HW105M+	AB	R	1 50V Electrolytic
△	C750	VCKYPA2HB102K+	AA	R	1000p 500V Ceramic
	C752	VCKYPH3DB561K	AC	R	560p 2000V Ceramic
	C753	RC-EZA523WJZZ	AD	R	100 160V Electrolytic
	C754	RC-EZA522WJZZ	AD	R	33 160V Electrolytic
	C756	VCEA0A1EW228M+	AE	R	2200 25V Electrolytic
	C757	VCKYCY1HB471KY	AA	R	470p 50V Ceramic
	C784	RC-KZ1018CEZZ+	AC	R	1000 2kV Ceramic
	C801	VCFYFA1HA105J+	AE	R	1 50V Metalized Polypro Film
	C802	VCKYCY1HF103ZY	AA	R	0.01 50V Ceramic
	C803	VCEA0A1CW108M+	AD	R	1000 16V Electrolytic
	C804	VCKYCY1HF103ZY	AA	R	0.01 50V Ceramic
	C805	VCEA0A1HW105M+	AB	R	1 50V Electrolytic
	C806	VCKYCY1HF103ZY	AA	R	0.01 50V Ceramic

NO.	PARTS CODE	PRICE RANK	NEW MARK	PART RANK	DESCRIPTION
[3] MAIN UNIT					
C807	VCEA0A1CW108M+	AD		R	1000 16V Electrolytic
C808	VCKYCY1HF103ZY	AA		R	0.01 50V Ceramic
C809	VCKYCY1HF103ZY	AA		R	0.01 50V Ceramic
C810	VCKYCY1HF103ZY	AA		R	0.01 50V Ceramic
C811	VCEA9M1CW107M+	AB		R	100 16V Electrolytic
C813	VCCCCY1HH181JY	AA		R	180p 50V Ceramic
C814	VCKYCY1HF103ZY	AA		R	0.01 50V Ceramic
C815	VCKYCY1HF103ZY	AA		R	0.01 50V Ceramic
C817	VCEA0A1CW107M+	AC		R	100 16V Electrolytic
C818	VCEA9M1HW475M+	AB		R	4.7 50V Electrolytic
C819	VCCCCY1HH121JY	AA		R	120p 50V Ceramic
C820	VCEA9M1HW474M+	AB		R	0.47 50V Electrolytic
C821	VCKYCY1HF153ZY	AA		R	0.015 50V Ceramic
C822	VCEA0A1HW105M+	AB		R	1 50V Electrolytic
C823	VCKYCY1EF104ZY	AA		R	0.1 25V Ceramic
C824	VCEA0A1CW337M+	AC		R	330 16V Electrolytic
C825	VCEA0A1HW105M+	AB		R	1 50V Electrolytic
C827	VCEA0A1CW477M+	AC		R	470 16V Electrolytic
C828	VCKYCY1HF103ZY	AA		R	0.01 50V Ceramic
C829	VCEA0A1CW476M+	AB		R	47 16V Electrolytic
C831	VCKYCY1EF104ZY	AA		R	0.1 25V Ceramic
C833	VCKYCY1EF104ZY	AA		R	0.1 25V Ceramic
C834	VCEA0A1CW476M+	AB		R	47 16V Electrolytic
C835	VCEA0A1CW106M+	AB		R	10 16V Electrolytic
C837	VCEA9M1HW474M+	AB		R	0.47 50V Electrolytic
C839	VCKYCY1HB392KY	AA		R	3900p 50V Ceramic
C840	VCFYFA1HA105J+	AE		R	1 50V Metalized Polypro Film
C841	VCCCCY1HH220JY	AA		R	22p 50V Ceramic
C842	VCEA0A1HW474M+	AB		R	0.47 50V Electrolytic
C843	VCEA9M1HW105M+	AB		R	1 50V Electrolytic
C845	VCKYCY1CF224ZY	AB		R	0.22 16V Ceramic
C847	VCCCCY1HH220JY	AA		R	22p 50V Ceramic
C848	VCEA0A1HW474M+	AB		R	0.47 50V Electrolytic
C1003	VCEA0A1CW106M+	AB		R	10 16V Electrolytic
C1004	VCKYCY1CF474ZY	AB		R	0.47 16V Ceramic
C1006	VCEA0A1HW225M+	AB		R	2.2 50V Electrolytic
C1007	VCEA0A1CW107M+	AC		R	100 16V Electrolytic
C1008	VCKYCY1HF103ZY	AA		R	0.01 50V Ceramic
C1009	VCKYCY1HF103ZY	AA		R	0.01 50V Ceramic
C1011	VCKYCY1HB221KY	AA		R	220p 50V Ceramic
C1012	VCEA0A1HW105M+	AB		R	1 50V Electrolytic
C1014	VCEA0A1HW475M+	AB		R	4.7 50V Electrolytic
C1015	VCCCPA1HH101J+	AA		R	100p 50V Ceramic
C1016	VCKYCY1EF104ZY	AA		R	0.1 25V Ceramic
C1081	VCQYTA1HM104J+	AB		R	0.1 50V Mylar
C1170	VCEA0A1CW107M+	AC		R	100 16V Electrolytic
C1801	VCEA9M1CW106M+	AB		R	10 16V Electrolytic
C1849	VCFYFA1HA104J+	AA		R	0.1 50V Metalized Polypro Film
C1851	VCFYFA1HA224J+	AB		R	0.22 50V Metalized Polypro Film
C1852	VCFYFA1HA224J+	AB		R	0.22 50V Metalized Polypro Film
C1853	VCFYFA1HA105J+	AE		R	1 50V Metalized Polypro Film
C1856	VCKYCY1HB102KY	AA		R	1000p 50V Ceramic
C1867	VCCCCY1HH150JY	AA		R	15p 50V Ceramic
C1868	VCEA0A1CW336M+	AB		R	33 16V Electrolytic
C3501	VCKYCY1CF224ZY	AB		R	0.22 16V Ceramic
C3502	VCKYCY1CF224ZY	AB		R	0.22 16V Ceramic
C3503	VCKYCY1CF224ZY	AB		R	0.22 16V Ceramic
C3504	VCKYCY1CF224ZY	AB		R	0.22 16V Ceramic
C3505	VCKYCY1CF224ZY	AB		R	0.22 16V Ceramic
C3506	VCKYCY1CF224ZY	AB		R	0.22 16V Ceramic
C3507	VCEA0A1HW475M+	AB		R	4.7 50V Electrolytic
C3508	VCEA0A1HW475M+	AB		R	4.7 50V Electrolytic
C3509	VCKYCY1HF223ZY	AB		R	0.022 50V Ceramic
C3510	VCKYCY1HF223ZY	AB		R	0.022 50V Ceramic
C3511	VCKYCY1HB222KY	AA		R	2200p 50V Ceramic
C3512	VCKYCY1HB222KY	AA		R	2200p 50V Ceramic
C3513	VCKYCY1CF224ZY	AB		R	0.22 16V Ceramic
C3514	VCKYCY1CF224ZY	AB		R	0.22 16V Ceramic
C3515	VCEA0A1HW474M+	AB		R	0.47 50V Electrolytic
C3516	VCEA0A1HW474M+	AB		R	0.47 50V Electrolytic
C3517	VCEA0A1HW105M+	AB		R	1 50V Electrolytic
C3518	VCKYCY1CF334ZY	AB		R	0.33 16V Ceramic
C3519	VCEA0A1HW105M+	AB		R	1 50V Electrolytic
C3520	VCEA0A1HW105M+	AB		R	1 50V Electrolytic
C3521	VCEA0A1HW105M+	AB		R	1 50V Electrolytic
C3522	VCEA0A1HW105M+	AB		R	1 50V Electrolytic
C3523	VCKYCY1CF104ZY	AA		R	0.1 16V Ceramic
C3524	VCEA0A1CW108M+	AD		R	1000 16V Electrolytic
C3525	VCKYCY1HF103ZY	AA		R	0.01 50V Ceramic
C3526	VCKYCY1HF103ZY	AA		R	0.01 50V Ceramic
R201	VRS-CY1JF101JY	AA		R	100 1/16W Metal Oxide
R202	VRS-CY1JF101JY	AA		R	100 1/16W Metal Oxide
R216	VRS-RG3LB393J+			R	39k 3.0W Metal Oxide
R301	VRS-CY1JF102JY	AA		R	1k 1/16W Metal Oxide
R302	VRN-RL3DBR10J+	AB		R	0.1 2W Metal Film

NO.	PARTS CODE	PRICE RANK	NEW MARK	PART RANK	DESCRIPTION
[3] MAIN UNIT					
R303	VRS-CY1JF473JY	AA		R	47k 1/16W Metal Oxide
R304	VRD-RA2BE683JY	AA		R	68k 1/8W Carbon
R305	VRS-CY1JF274JY	AA		R	270k 1/16W Metal Oxide
R307	VRS-CY1JF122JY	AA		R	1.2k 1/16W Metal Oxide
R308	VRD-RA2BE562JY	AA		R	5.6k 1/8W Carbon
R314	VRD-RA2BE562JY	AA		R	5.6k 1/8W Carbon
R315	VRS-CY1JF122JY	AA		R	1.2k 1/16W Metal Oxide
R318	VRD-RA2BE680JY	AA		R	68 1/8W Carbon
R319	VRD-RA2BE680JY	AA		R	68 1/8W Carbon
R353	VRS-CY1JF102JY	AA		R	1k 1/16W Metal Oxide
R356	VRD-RA2BE102JY	AA		R	1k 1/8W Carbon
R362	VRS-CY1JF332JY	AA		R	3.3k 1/16W Metal Oxide
R366	VRS-CY1JF332JY	AA		R	3.3k 1/16W Metal Oxide
R372	VRS-CY1JF104JY	AA		R	100k 1/16W Metal Oxide
R373	VRS-CY1JF103JY	AA		R	10k 1/16W Metal Oxide
R374	VRS-CY1JF104JY	AA		R	100k 1/16W Metal Oxide
R376	VRD-RA2BE472JY	AA		R	4.7k 1/8W Carbon
R382	VRD-RA2BE332JY	AA		R	3.3k 1/8W Carbon
R384	VRD-RA2BE332JY	AA		R	3.3k 1/8W Carbon
R431	VRS-CY1JF101JY	AA		R	100 1/16W Metal Oxide
R432	VRS-CY1JF750JY	AA		R	75 1/16W Metal Oxide
R433	VRS-CY1JF750JY	AA		R	75 1/16W Metal Oxide
R434	VRS-CY1JF750JY	AA		R	75 1/16W Metal Oxide
R435	VRS-CY1JF750JY	AA		R	75 1/16W Metal Oxide
R436	VRD-RA2BE101JY	AA		R	100 1/8W Carbon
R437	VRS-CY1JF101JY	AA		R	100 1/16W Metal Oxide
R458	VRS-CY1JF103JY	AA		R	10k 1/16W Metal Oxide
R459	VRD-RA2EE750JY	AA		R	75 1/4W Carbon
R461	VRS-CY1JF750JY	AA		R	75 1/16W Metal Oxide
R462	VRD-RA2BE101JY	AA		R	100 1/8W Carbon
R503	VRN-RL3DB1R2J+	AB		R	1.2 2W Metal Film
R504	VRS-CY1JF222JY	AA		R	2.2k 1/16W Metal Oxide
R506	VRS-RG3AB331J+	AB		R	330 1W Metal Oxide
R507	VRD-RM2HD1R0JY	AA		R	1 1/2W Carbon
R513	VRD-RM2HD333JY	AB		R	33k 1/2W Carbon
R514	VRD-RM2HD682JY	AA		R	6.8k 1/2W Carbon
R515	VRS-CY1JF393JY	AA		R	39k 1/16W Metal Oxide
R520	VRS-CY1JF223JY	AA		R	22k 1/16W Metal Oxide
R523	VRD-RA2BE103JY	AA		R	10k 1/8W Carbon
R524	VRD-RA2BE103JY	AA		R	10k 1/8W Carbon
R525	VRD-RA2BE102JY	AA		R	1k 1/8W Carbon
R526	VRD-RA2BE101JY	AA		R	100 1/8W Carbon
R601	VRD-RM2HD820JY	AA		R	82 1/2W Carbon
R602	VRD-RA2BE393JY	AA		R	39k 1/8W Carbon
R603	VRD-RA2BE393JY	AA		R	39k 1/8W Carbon
R604	VRD-RA2BE473JY	AA		R	47k 1/8W Carbon
R605	VRD-RM2HD104JY	AA		R	100k 1/2W Carbon
R607	VRD-RM2HD121JY	AA		R	120 1/2W Carbon
△	R608	VRD-RM2HD102JY	AA	R	1k 1/2W Carbon
△	R611	VRN-RL3AB1R5J+	AB	R	1.5 1W Metal Film
△	R612	VRD-RM2HD270JY	AA	R	27 1/2W Carbon
R614	VRD-RA2BE154JY	AA		R	150k 1/8W Carbon
R615	VRD-RA2BE102JY	AA		R	1k 1/8W Carbon
R616	VRD-RA2BE102JY	AA		R	1k 1/8W Carbon
R617	VRS-CY1JF123JY	AA		R	12k 1/16W Metal Oxide
R618	VRS-CY1JF103JY	AA		R	10k 1/16W Metal Oxide
R621	VRN-RL2HC4R7J+	AB		R	4.7 1/2W Metal Film
R622	VRS-VV3DB682J	AA		R	6.8k 2W Metal Oxide
R625	VRD-RM2HD184JY	AA		R	180k 1/2W Carbon
R626	VRS-CY1JF472JY	AA		R	4.7k 1/16W Metal Oxide
R627	VRD-RA2BE103JY	AA		R	10k 1/8W Carbon
R631	VRS-KT3LB391J	AD		R	390 3.0W Metal Oxide
R637	VRD-RA2BE331JY	AA		R	330 1/8W Carbon
R638	VRD-RA2BE181JY	AA		R	180 1/8W Carbon
R639	VRD-RM2HD271JY	AA		R	270 1/2W Carbon
R642	VRN-RL3DB1R0J+	AB		R	1 2W Metal Film
R661	VRD-RA2BE102JY	AA		R	1k 1/8W Carbon
R662	VRD-RA2BE103JY	AA		R	10k 1/8W Carbon
R701	VRD-RM2HD154JY	AA		R	150k 1/2W Carbon
△	R704	VRD-RA2BE221JY	AA	R	220 1/8W Carbon
R710	VRD-RM2HD220JY	AA		R	22 1/2W Carbon
R711	VRD-RA2EE682JY	AA		R	6.8k 1/4W Carbon
△	R718	VRC-UA2HG275KY	AC	R	2.7 M 1/2W Solid
R721	VRD-RA2BE222JY	AA		R	2.2k 1/8W Carbon
R722	VRD-RA2BE333GY	AB		R	33k 1/8W 2% Carbon
R725	VRD-RM2HD821JY	AA		R	820 1/2W Carbon
R726	VRN-RL2HCR47J+	AB		R	0.47 1/2W Metal Film
△	R751	VRC-UA2HG825KY	AA	R	8.2 M 1/2W Solid
△	R752	VRC-UA2HG825KY	AA	R	8.2 M 1/2W Solid
R753	VRD-RM2HD334JY	AA		R	330k 1/2W Carbon
R754	VRN-RL3AB8R2J+	AB		R	8.2 1W Metal Film
R756	VRS-RG3DB121J+	AB		R	120 2W Metal Oxide
R801	VRS-CY1JF102JY	AA		R	1k 1/16W Metal Oxide
R802	VRS-CY1JF682JY	AA		R	6.8k 1/16W Metal Oxide
R803	VRS-CY1JF103JY	AA		R	10k 1/16W Metal Oxide

NO.	PARTS CODE	PRICE RANK	NEW MARK	PART RANK	DESCRIPTION
[3] MAIN UNIT					
R804	VRS-CY1JF222JY	AA		R	2.2k 1/16W Metal Oxide
R805	VRS-CY1JF222JY	AA		R	2.2k 1/16W Metal Oxide
R806	VRS-CY1JF222JY	AA		R	2.2k 1/16W Metal Oxide
R807	VRS-CY1JF222JY	AA		R	2.2k 1/16W Metal Oxide
R370	VRS-CY1JF471JY	AA		R	470 1/16W Metal Oxide
R371	VRS-CY1JF471JY	AA		R	470 1/16W Metal Oxide
J351	QJAKJ0101SEZZ	AE		R	Jack
P352	QPLGNA108WJZZ	AB		R	Plug
P351	QPLGNA109WJZZ	AB		R	Plug
R808	VRD-RA2BE273JY	AA		R	27k 1/8W Carbon
R812	VRD-RA2BE101JY	AA		R	100 1/8W Carbon
R814	VRS-CY1JF473JY	AA		R	47k 1/16W Metal Oxide
R815	VRS-CY1JF473JY	AA		R	47k 1/16W Metal Oxide
R816	VRS-CY1JF223JY	AA		R	22k 1/16W Metal Oxide
R817	VRS-CY1JF473JY	AA		R	47k 1/16W Metal Oxide
R821	VRS-CY1JF681JY	AA		R	680 1/16W Metal Oxide
R823	VRD-RA2BE101JY	AA		R	100 1/8W Carbon
R824	VRD-RA2BE101JY	AA		R	100 1/8W Carbon
R826	VRD-RA2BE101JY	AA		R	100 1/8W Carbon
R829	VRD-RA2BE472JY	AA		R	4.7k 1/8W Carbon
R830	VRS-CY1JF393JY	AA		R	39k 1/16W Metal Oxide
R831	VRD-RA2BE331JY	AA		R	330 1/8W Carbon
R832	VRS-CY1JF822JY	AA		R	8.2k 1/16W Metal Oxide
R833	VRS-CY1JF220JY	AA		R	22 1/16W Metal Oxide
R835	VRS-CY1JF332JY	AA		R	3.3k 1/16W Metal Oxide
R837	VRD-RM2HD151JY	AA		R	150 1/2W Carbon
R838	VRD-RA2BE105JY	AA		R	1 M 1/8W Carbon
R839	VRD-RA2BE101JY	AA		R	100 1/8W Carbon
R840	VRS-CY1JF124JY	AA		R	120k 1/16W Metal Oxide
R841	VRD-RA2BE152JY	AA		R	1.5k 1/8W Carbon
R842	VRS-CY1JF562JY	AA		R	5.6k 1/16W Metal Oxide
R843	VRD-RA2BE103JY	AA		R	10k 1/8W Carbon
R1002	VRS-CY1JF183JY	AA		R	18k 1/16W Metal Oxide
R1003	VRS-CY1JF822JY	AA		R	8.2k 1/16W Metal Oxide
R1005	VRD-RA2BE101JY	AA		R	100 1/8W Carbon
R1006	VRS-CY1JF822JY	AA		R	8.2k 1/16W Metal Oxide
R1007	VRS-CY1JF103JY	AA		R	10k 1/16W Metal Oxide
R1008	VRS-CY1JF183JY	AA		R	18k 1/16W Metal Oxide
R1009	VRS-CY1JF103JY	AA		R	10k 1/16W Metal Oxide
R1011	VRD-RA2BE101JY	AA		R	100 1/8W Carbon
R1012	VRD-RA2BE101JY	AA		R	100 1/8W Carbon
R1013	VRD-RA2BE391JY	AA		R	390 1/8W Carbon
R1024	VRS-CY1JF101JY	AA		R	100 1/16W Metal Oxide
R1027	VRS-CY1JF104JY	AA		R	100k 1/16W Metal Oxide
R1031	VRD-RA2BE101JY	AA		R	100 1/8W Carbon
R1032	VRS-CY1JF332JY	AA		R	3.3k 1/16W Metal Oxide
R1034	VRS-CY1JF104JY	AA		R	100k 1/16W Metal Oxide
R1035	VRD-RA2BE101JY	AA		R	100 1/8W Carbon
R1036	VRS-CY1JF103JY	AA		R	10k 1/16W Metal Oxide
R1037	VRS-CY1JF103JY	AA		R	10k 1/16W Metal Oxide
R1038	VRS-CY1JF562JY	AA		R	5.6k 1/16W Metal Oxide
R1039	VRS-CY1JF102JY	AA		R	1k 1/16W Metal Oxide
R1041	VRS-CY1JF102JY	AA		R	1k 1/16W Metal Oxide
R1042	VRD-RA2BE101JY	AA		R	100 1/8W Carbon
R1043	VRS-CY1JF104JY	AA		R	100k 1/16W Metal Oxide
R1045	VRD-RA2BE101JY	AA		R	100 1/8W Carbon
R1046	VRS-CY1JF101JY	AA		R	100 1/16W Metal Oxide
R1047	VRS-CY1JF183JY	AA		R	18k 1/16W Metal Oxide
R1048	VRS-CY1JF101JY	AA		R	100 1/16W Metal Oxide
R1049	VRS-CY1JF183JY	AA		R	18k 1/16W Metal Oxide
R1050	VRD-RA2BE103JY	AA		R	10k 1/8W Carbon
R1051	VRD-RA2BE104JY	AA		R	100k 1/8W Carbon
R1053	VRD-RA2BE101JY	AA		R	100 1/8W Carbon
R1054	VRD-RA2BE101JY	AA		R	100 1/8W Carbon
R1055	VRD-RA2BE332JY	AA		R	3.3k 1/8W Carbon
R1056	VRS-CY1JF332JY	AA		R	3.3k 1/16W Metal Oxide
R1057	VRS-CY1JF101JY	AA		R	100 1/16W Metal Oxide
R1061	VRS-CY1JF102JY	AA		R	1k 1/16W Metal Oxide
R1063	VRS-CY1JF103JY	AA		R	10k 1/16W Metal Oxide
R1064	VRS-CY1JF103JY	AA		R	10k 1/16W Metal Oxide
R1065	VRS-CY1JF103JY	AA		R	10k 1/16W Metal Oxide
R1066	VRS-CY1JF102JY	AA		R	1k 1/16W Metal Oxide
R1072	VRS-CY1JF221JY	AA		R	220 1/16W Metal Oxide
R1073	VRD-RA2BE101JY	AA		R	100 1/8W Carbon
R1074	VRS-CY1JF332JY	AA		R	3.3k 1/16W Metal Oxide
R1076	VRS-CY1JF102JY	AA		R	1k 1/16W Metal Oxide
R1078	VRS-CY1JF332JY	AA		R	3.3k 1/16W Metal Oxide
R1079	VRS-CY1JF332JY	AA		R	3.3k 1/16W Metal Oxide
R1087	VRS-CY1JF391JY	AA		R	390 1/16W Metal Oxide
R1170	VRD-RA2BE103JY	AA		R	10k 1/8W Carbon
R1171	VRS-CY1JF103JY	AA		R	10k 1/16W Metal Oxide
R1172	VRS-CY1JF222JY	AA		R	2.2k 1/16W Metal Oxide
R1511	VRS-CY1JF000JY	AA		R	0 1/16W Metal Oxide
R1801	VRS-CY1JF222JY	AA		R	2.2k 1/16W Metal Oxide
R1802	VRD-RA2BE124JY	AA		R	120k 1/8W Carbon

NO.	PARTS CODE	PRICE RANK	NEW MARK	PART RANK	DESCRIPTION
[3] MAIN UNIT					
R1849	VRS-CY1JF272JY	AA		R	2.7k 1/16W Metal Oxide
R1850	VRS-CY1JF681JY	AA		R	680 1/16W Metal Oxide
R1851	VRS-CY1JF221JY	AA		R	220 1/16W Metal Oxide
R1852	VRS-CY1JF221JY	AA		R	220 1/16W Metal Oxide
R1853	VRS-CY1JF221JY	AA		R	220 1/16W Metal Oxide
R1854	VRS-CY1JF103JY	AA		R	10k 1/16W Metal Oxide
R1855	VRS-CY1JF122JY	AA		R	1.2k 1/16W Metal Oxide
R1856	VRS-CY1JF223JY	AA		R	22k 1/16W Metal Oxide
R1894	VRD-RA2BE223JY	AA		R	22k 1/8W Carbon
R1895	VRS-CY1JF473JY	AA		R	47k 1/16W Metal Oxide
R1896	VRS-CY1JF473JY	AA		R	47k 1/16W Metal Oxide
R3006	VRS-CY1JF101JY	AA		R	100 1/16W Metal Oxide
R3009	VRS-CY1JF101JY	AA		R	100 1/16W Metal Oxide
R3501	VRD-RA2BE101JY	AA		R	100 1/8W Carbon
R3502	VRD-RA2BE101JY	AA		R	100 1/8W Carbon
R3503	VRD-RA2BE101JY	AA		R	100 1/8W Carbon
R3504	VRS-CY1JF101JY	AA		R	100 1/16W Metal Oxide
R3505	VRD-RA2BE101JY	AA		R	100 1/8W Carbon
R3506	VRS-CY1JF101JY	AA		R	100 1/16W Metal Oxide
R3507	VRD-RA2BE101JY	AA		R	100 1/8W Carbon
R3508	VRD-RA2BE101JY	AA		R	100 1/8W Carbon
R3509	VRD-RA2BE100JY	AA		R	10 1/8W Carbon
RJ1	VRS-CY1JF000JY	AA		R	0 1/16W Metal Oxide
RJ10	VRS-CY1JF000JY	AA		R	0 1/16W Metal Oxide
RJ12	VRS-CY1JF000JY	AA		R	0 1/16W Metal Oxide
RJ15	VRS-CY1JF000JY	AA		R	0 1/16W Metal Oxide
RJ16	VRS-CY1JF000JY	AA		R	0 1/16W Metal Oxide
RJ42	VRS-CY1JF000JY	AA		R	0 1/16W Metal Oxide
RJ43	VRS-CY1JF000JY	AA		R	0 1/16W Metal Oxide
RJ61	VRS-CY1JF000JY	AA		R	0 1/16W Metal Oxide
RJ63	VRS-CY1JF000JY	AA		R	0 1/16W Metal Oxide
S1001	QSW-K0202PEZZ+	AC		R	Switch
S1002	QSW-K0202PEZZ+	AC		R	Switch
S1003	QSW-K0202PEZZ+	AC		R	Switch
S1004	QSW-K0202PEZZ+	AC		R	Switch
S1005	QSW-K0202PEZZ+	AC		R	Switch
S701	QSW-P0612CEZZ	AG		R	Switch
F701	QFS-C3225CEZZ	AC		R	Fuse, 3.15A 250V
FB601	RBLN-A034WJZZY	AA		R	Balun
FH701	QFSHD1013CEZZ+	AC		R	Fuse Holder
FH702	QFSHD1014CEZZ+	AC		R	Fuse Holder
J401	QJAKGA015WJZZ	AH		R	Jack
J402	QJAKEA056WJ04	AB		R	Jack
J403	QJAKEA056WJ09	AB		R	Jack
J404	QJAKEA070WJ02			R	Jack
J405	QTANJ0644CEZZ	AM		R	Terminal
P302	QPLGN0461CEZZA	AB		R	Plug, 4pins
P304	QPLGN0761CEZZA	AC		R	Plug, 7pins
P601	QPLGN0660CEZZ	AC		R	Plug, 6pins
P602	QPLGN0561CEZZA	AB		R	Plug, 5pins
P701	QPLGN0260CEZZ	AC		R	Plug, 2pins
P702	QPLGN0269GEZZ	AB		R	Plug, 2pins
P1001	QPLGN0578GEZZ	AB		R	Plug, 5pins
P1002	QPLGN0561CEZZ	AB		R	Plug, 5pins
RMC1001	RRMCUA022WJZZ	AG		R	Remote Receiver
RDA301	PRDARA120WJFW	AD		R	Audio Heatsink
RDA392	PRDARA167WJFW	AD		R	Heat Sink, D392
RDA501	PRDARA120WJFW	AD		R	Heat Sink, IC501
RDA601	PRDARA167WJFW	AD		R	Heat Sink, IC601
RDA602	PRDAR0337PEFW	AD		R	Heat Sink, Q602
RDA701	PRDARA119WJFW	AF		R	Heat Sink, IC701
NR701	RH-HXA013WJZZ+	AD		R	Thermistor
TP801	QLUGP0111GEFW	AA		R	Lug
[4] CRT UNIT					
Q853	RH-TX0110BMZZ+	AC		R	Transistor, BF422
Q854	RH-TX0110BMZZ+	AC		R	Transistor, BF422
Q855	RH-TX0110BMZZ+	AC		R	Transistor, BF422
Q894	VS2PA1015Y+-1+	AC		R	Transistor, 2PA1015Y
D859	VHD1SS119//--1Y	AA		R	Diode, 1SS119
D896	RH-EX0616GEZZY	AA		R	Zener Diode, 5.9V
D898	VHD1SS119//--1Y	AA		R	Diode, 1SS119
L851	VP-MK820K0000+	AB		R	Peaking 82µH
C851	VCKYPA1HB561K+	AA		R	560p 50V Ceramic
C852	VCKYPA1HB391K+	AA		R	390p 50V Ceramic
C853	VCKYPA1HB271K+	AB		R	270p 50V Ceramic
C880	RC-KZ0016CEZZ	AC		R	0.01 250V Ceramic
C893	VCEA0A1CW336M+	AB		R	33 16V Electrolytic
R849	VRD-RA2BE271JY	AA		R	270 1/8W Carbon
R850	VRD-RA2BE470JY	AA		R	47 1/8W Carbon
R851	VRD-RA2BE470JY	AA		R	47 1/8W Carbon
R852	VRD-RA2BE470JY	AA		R	47 1/8W Carbon
R854	VRD-RA2BE271JY	AA		R	270 1/8W Carbon
R855	VRD-RA2BE271JY	AA		R	270 1/8W Carbon
R859	VRS-VV3DB153J	AA		R	15k 2W Metal Oxide

NO.	PARTS CODE	PRICE RANK	NEW MARK	PART RANK	DESCRIPTION
[4] CRT UNIT					
△	R861	VRS-VV3DB153J	AA		R 15k 2W Metal Oxide
△	R863	VRS-VV3DB153J	AA		R 15k 2W Metal Oxide
	R864	VRD-RA2BE470JY	AA		R 47 1/8W Carbon
	R876	VRD-RA2BE121JY	AA		R 120 1/8W Carbon
	R877	VRD-RA2BE121JY	AA		R 120 1/8W Carbon
	R878	VRD-RA2BE121JY	AA		R 120 1/8W Carbon
	R880	VRD-RM2HD332JY	AA		R 3.3k 1/2W Carbon
	R881	VRD-RM2HD332JY	AA		R 3.3k 1/2W Carbon
	R882	VRD-RM2HD332JY	AA		R 3.3k 1/2W Carbon
	R889	VRD-RA2BE821JY	AA		R 820 1/8W Carbon
	R891	VRD-RA2BE561JY	AA		R 560 1/8W Carbon
	R892	VRD-RA2BE391JY	AA		R 390 1/8W Carbon
	R894	VRD-RA2BE152JY	AA		R 1.5k 1/8W Carbon
	R895	VRD-RA2BE561JY	AA		R 560 1/8W Carbon
	P860	QPLGN0561CEZZ	AB		R Plug, 5pins
	P880	QPLGN0578GEZZ	AB		R Plug, 5pins
	SC851	QSOCV0016PEZZ	AF		R CRT Socket
[5] HEADPHONE UNIT					
	R370	VRS-CY1JF471JY	AA		R 470 1/16W Metal Oxide
	R371	VRS-CY1JF471JY	AA		R 470 1/16W Metal Oxide
	J351	QJAKJ0101SEZZ	AE		R Jack
	P352	QPLGNA108WJZZ	AB		R Plug, 3pins
	P351	QPLGNA109WJZZ	AB		R Plug, 4pins
[6] MISCELLANEOUS PARTS					
		QCNW-A922WJZZ	AF		R K-Wire
		QCNW-A923WJZZ	AE		R H-Wire
		QCNW-B266WJZZ	AF		R H/P Wire
		LHLDKA004WJZZ			R AC Cord Holder
		LHLDW1002PEZZ	AB		R AC Holder
		QCNW-D818WJPZ			R Speaker Wire
		TCAUAA005WJZZ			R Caution Label
		VSP1206PB81WA			R Speaker 16 Ohm

[7] CABINET PARTS

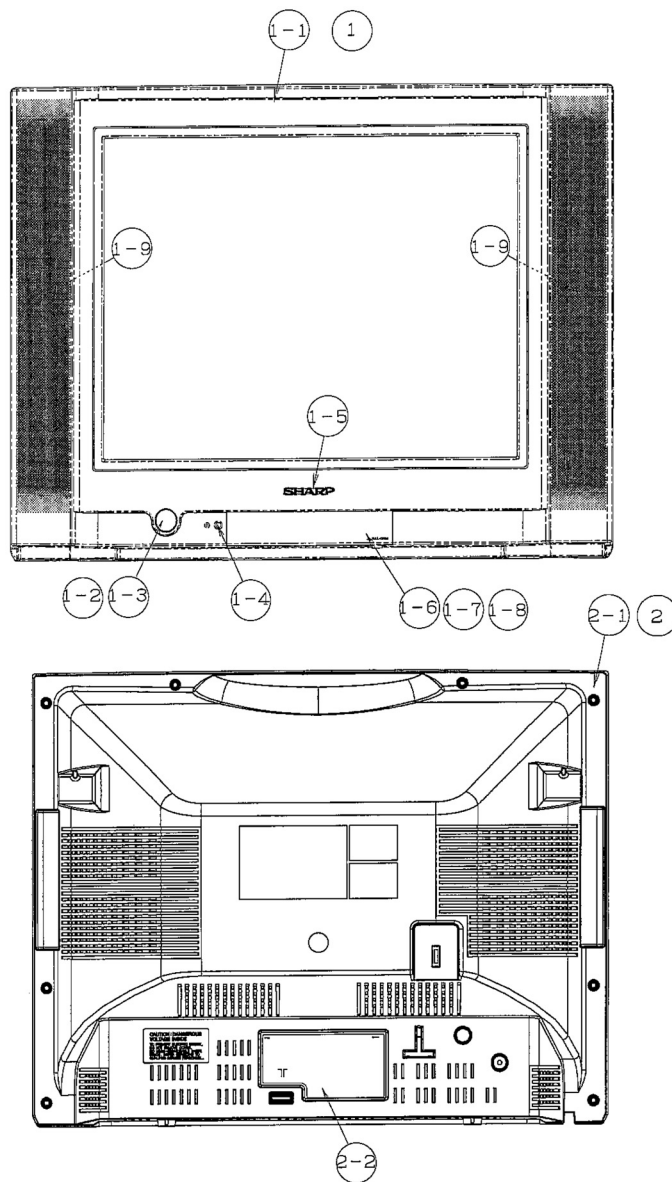

NO.	PARTS CODE	PRICE RANK	NEW MARK	PART RANK	DESCRIPTION
[7] CABINET PARTS					
1	CCABAB104WEV0			R	Font Cabinet Ass'y
1-1	Not Available	-		-	Font Cabinet
1-2	JBTN-A485WJSA			R	Power Button
1-3	MSPRC0005PEFW	AB		R	Spring for Button
1-4	GCOVAB345WJSA			R	R/C Cover
1-5	HBDGB3155CESA	AF		R	Sharp Badge
1-6	GDORFA158WJKA			R	Door
1-7	MSPRPA031WJFW	AB		R	Door Spring
1-8	HINDPB368WJZZ			R	Indication Plat
1-9	LHLDZA646WJZZ			R	Speaker Holder
2	CCABBA631WEV0			R	Rear Cabinrt Ass'y
2-1	Not Available	-		-	Rear Cabinrt
2-2	HINDPB418WJZZ			R	Indicator Plate(Rear)
[8] SUPPLIED ACCESSORIES					
△ X1	QACCZA048WJPZ			R	AC Cord
X2	RRMCGA296WJSB	AN		R	Remote Control
X3	TINS-B982WJZZ			R	Operation Manual
X4	TGAN-A101WJZZ	AC		R	Warranty Card

[9] PACKING PARTS

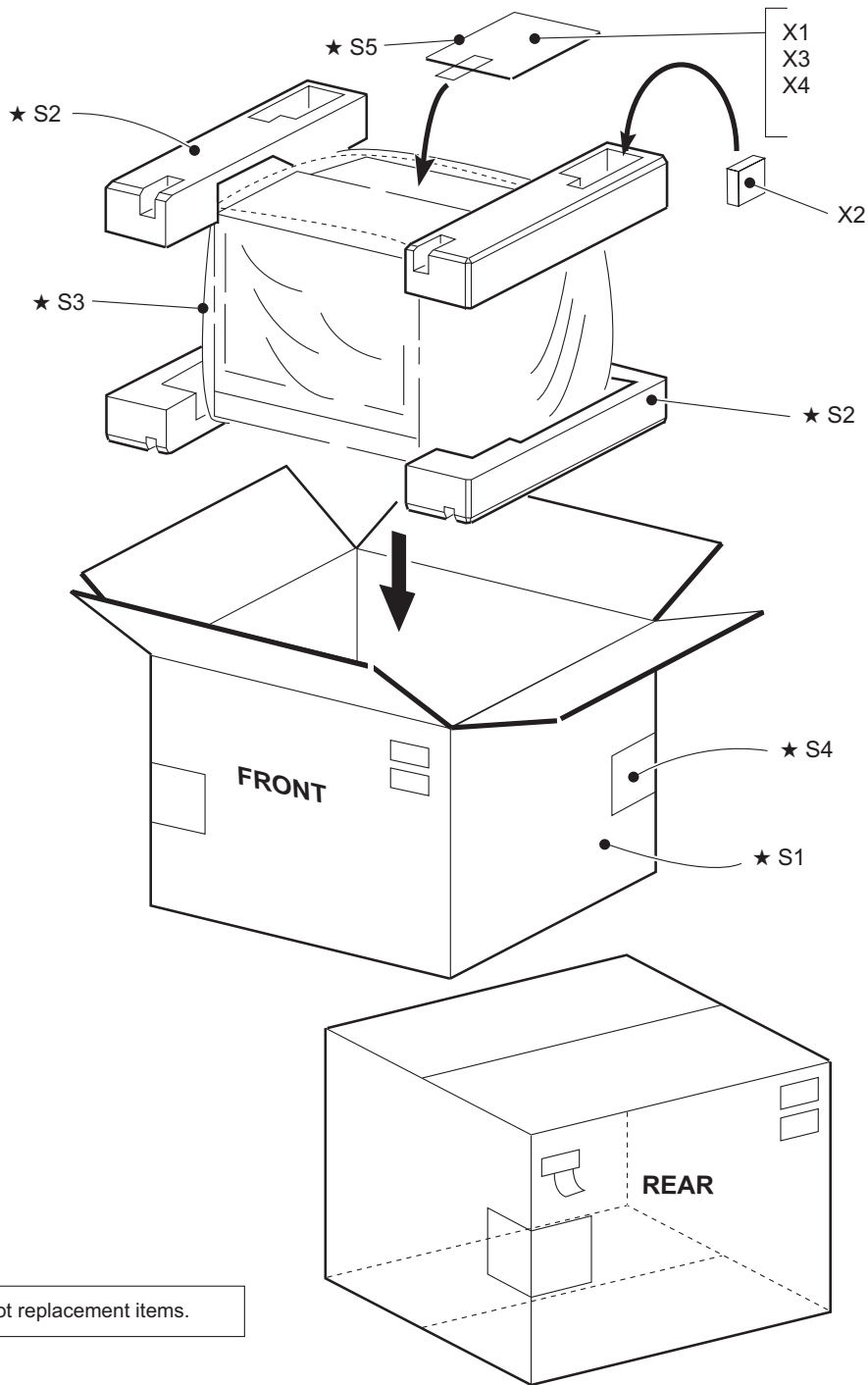

★ MARK : Not replacement items.

NO.	PARTS CODE	PRICE RANK	NEW MARK	PART RANK	DESCRIPTION
[9] PACKING PARTS					
					(NOT REPLACEMENT ITEM)
S1	SPAKCC260WJZZ	-		-	Packing Case
S2	SPAKXA822WJZZ	-		-	Packing Foam
S3	SSAKA0031PEZZ	-		-	Rrapping Sack
S4	TLABZB002WJZZ	-		-	Packing Label
S5	SPAKP0122PEZZ	-		-	Rrapping Sheet

SHARP

COPYRIGHT © 2005 BY SHARP CORPORATION

ALL RIGHTS RESERVED.

No part of this publication may be reproduced, stored in a retrieval system, or transmitted in any form or by any means, electronic, mechanical, photocopying, recording, or otherwise, without prior written permission of the publisher.

TQ1921-S
Aug. 2005 Printed in Japan

Design and Production Information	
Design	: SEM
Production	: SREC

MY. KD

SHARP CORPORATION
AV Systems Group
CS Promotion Center
Yaita, Tochigi 329-2193, Japan

www.s-manuals.com