

Silverwood

New Multisize Foldaway Cake Pan

Your new Silverwood Multisize cake pan is an updated and improved version of our original 3in deep Multisize cake pan. Like the original, your new pan will bake any square or rectangular cake from 12"(30cm) to 1"(2.5cm) or batch bake four 6" square cakes. Plus you can now bake 4in deep, for full-depth celebration cakes. For extra variety, bake four sponge cakes, each with different flavourings.

BEFORE USE:

Wash in hot soapy water, rinse and dry.

IN USE:

Cooking temperatures can be reduced by 10-15°C and you should check progress after 2/3 of normal cooking time. Cooking with some fats and oils may produce a light discolouration on the surface. As this patina builds up, the release properties of the bakeware continue to improve.

AFTER USE:

Hand wash in hot soapy water, rinse and dry.

HAND WASH ONLY - NOT SUITABLE FOR DISHWASHERS

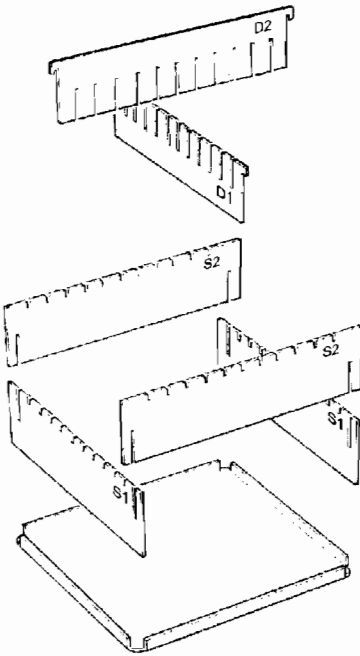

ASSEMBLY INSTRUCTIONS FOR YOUR MULTISIZE CAKE PAN

- 1) Make sure that all the sides and dividers are positioned with the identifying lettering the right way up.
- 2) Select two side pieces marked S1 and position them along two opposite edges of the base.
- 3) Select the two sides marked S2 and drop them into the two remaining edges of the base, locating the long end-slots into the opposing slots in the S1 pieces. Check that all side pieces sit within the upturned rim, with their lower edges on the base.
- 4) The two final pieces are dividers, D1 and D2. They should be positioned to divide up the pan into the shape and size you require. Always put D1 in position before D2.
- 5) Always remember to hold the assembled pan by the base, not the sides, when lifting..

EXTRA DIVIDER SETS AVAILABLE

Following numerous requests, we now also produce a pair of extra dividers for the new pan. With the new extra divider set (10044) you can batch bake multiple small square cakes (up to 9 cakes at a time with one extra set).

Also, many ovens have hot spots around the edges which can cause uneven baking. Using the extra divider set, you can position your cake to avoid these hot spots.

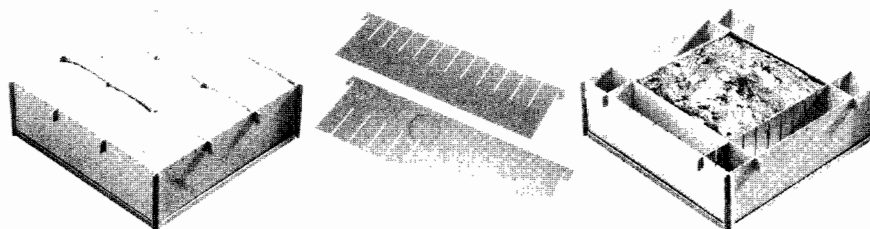

Extra divider set (10044) extends your options

Rich Fruit Cake Recipe Suggestion

Developed by the cookery editors of *Family Circle magazine* specifically for making a tiered wedding cake with our multisize cake pan, this recipe produces a rich, dark and moist cake which cuts well without crumbling.

1. Prepare a cool oven (150°C, 300°F, Gas 2).
2. Grease and double-line the cake pan with non-stick baking parchment.
3. Halve, wash and dry the cherries and place in a large bowl. Weigh and add the flour, currants, sultanas, raisins, mixed peel, nuts and spice
4. In another large bowl, cream the butter and sugar until light and fluffy. Gradually add the beaten eggs, beating well after each addition. Add a little of the flour and fruit if the mixture begins to curdle.
5. Add any desired essences and a little gravy browning or black treacle to give a darker mixture if desired. Mix in the rest of the fruit and flour mixture.
6. Put into the prepared cake pan and level the top with the back of a spoon. Place the cake in the oven and reduce the temperature to very cool: (140°C, 275°F, Gas 1). Cook for the time stated in the chart, but check 30 minutes before the end of the stated time. When cooked, the cake should feel firm to touch. Remove from the oven and allow to cool in the cake pan.
7. When cold, remove from pan; leave the parchment on to keep cake moist. Turn the cake upside down, wrap in more parchment and then kitchen foil. Keep in a cool, dark place. The cake improves with keeping and may be fed with a little brandy, sherry or rum to improve its flavour.

IMPERIAL

Square Cake Sizes	6in	7in	8in	9in	10in	11in	12in
Depth	3in	3in	3in	3in	3¼in	3½in	4in
Glace cherries	3oz	4oz	5oz	7oz	10oz	13oz	1lb 2oz
Plain flour	7oz	9oz	11oz	1 lb	1lb 7oz	1lb 13oz	2lb 7oz
Currants	6oz	8oz	10oz	14oz	1lb 5oz	1lb 11oz	2lb 4oz
Sultanas	9oz	12oz	15oz	1lb 5oz	1lb 14oz	2lb 8oz	3lb 4oz
Raisins	3oz	4oz	5oz	7oz	11oz	14oz	1lb 2oz
Mixed peel	2oz	2oz	3oz	4oz	5oz	7oz	9oz
Chopped nuts	1oz	2oz	3oz	3oz	4oz	6oz	8oz
Ground mixed spice	1 tsp	1 tsp	2 tsp	2 tsp	1 tbsp	1 tbsp	1½ tbsp
Butter	6oz	8oz	10oz	14oz	1lb 5oz	1lb 11oz	2lb 3oz
Caster sugar	6oz	8oz	10oz	14oz	1lb 5oz	1lb 11oz	2lb 3oz
Eggs (size2)	3	4	5	7	10	13	17
Cooking time (hrs)	3¼	4	4½	5	5	5	6

METRIC

Square Cake Sizes	15cm	18cm	20cm	23cm	25cm	28cm	30cm
Depth	7.5cm	7.5cm	7.5cm	7.5cm	8cm	9cm	10cm
Glace cherries	75g	100g	150g	200g	275g	375g	500g
Plain flour	200g	250g	300g	450g	650g	825g	1.1Kg
Currants	175g	225g	275g	400g	600g	750g	1Kg
Sultanas	250g	350g	425g	600g	850g	1.1 kg	1.5Kg
Raisins	75g	100g	150g	200g	300g	400g	500g
Mixed peel	50g	50g	75g	100g	150g	200g	250g
Chopped nuts	25g	80g	75g	75g	100g	175g	225g
Ground mixed spice	1 tsp	1 tsp	2 tsp	2 tsp	1 tbsp	1 tbsp	1½ tbsp
Butter	175g	225g	275g	400g	600g	750g	1Kg
Caster sugar	175g	225g	275g	400g	600g	750g	1Kg
Eggs (size2)	3	4	5	7	10	13	17
Cooking time (hrs)	3¼	4	4½	5	5	5	6