

œrlikon
leybold vacuum

Sogevac[®] SV10-16 B

Single-stage, oil-sealed rotary vane pump

Operating instructions GA02313_002_02

Réf. :

960 100
960 101
960 105
960 106
960 110
960 114
960 115
960 160
960 161
960 165
960 166
960 170
960 174
960 175

and their variants

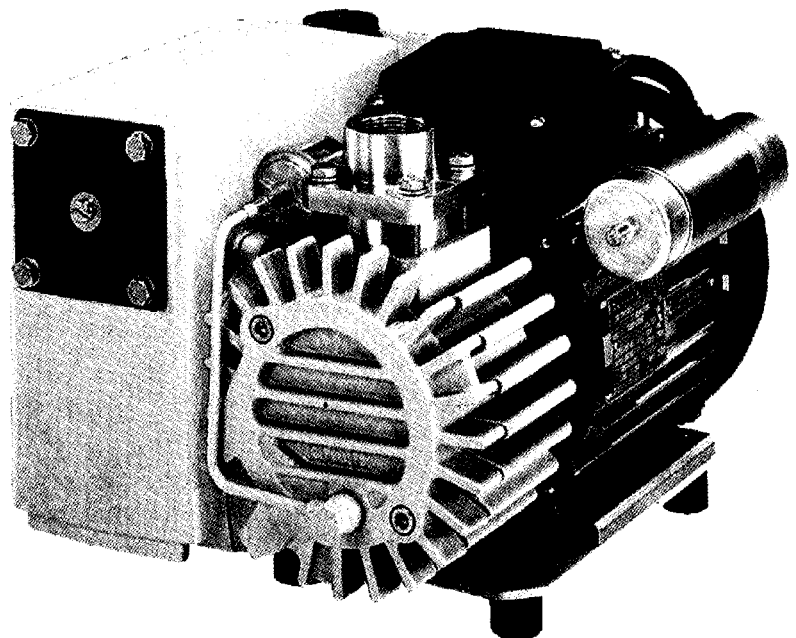

Contents

	Page
Important Safety Information	3
1 Description	5
1.1 Principle of operation	5
1.2 Technical characteristics	6
1.3 Connection fittings	8
1.4 Spare parts	9
1.5 Lubricants	9
2 Transport and storing	10
2.1 Transport and packing	10
2.2 Mounting orientation	10
2.3 Storage	10
3 Installation	11
3.1 Setting-up	11
3.2 Inlet connection	11
3.3 Connection to exhaust side	11
3.4 Oil filling	11
3.5 Electrical connection	12
4 Operation	13
4.1 Operating advices	13
4.2 Shutdown	13
5 Maintenance	14
5.1 Safety Information	14
5.2 Maintenance Intervals	14
5.3 Oerlikon Leybold Vacuum Service	15
5.4 Maintenance Work	15
6 Troubleshooting	17
7 Spare parts	18
EC Conformance Declaration	24
Declaration of Contamination of Compressors, Vacuum Pumps and Components	25

Safety Information

Important Safety Information

Indicates procedures that must be strictly observed to prevent hazards to persons.

Indicates procedures that must be strictly observed to prevent damage to, or destruction of the product:

Emphasises additional application information and other useful information provided within these Operating Instructions.

Warning

Caution

Note

The Oerlikon Leybold Vacuum Sogevac® SV10-16 B has been designed for safe and efficient operation when used properly and in accordance with these Operating Instructions. It is the responsibility of the user to carefully read and strictly observe all safety precautions described in this section and throughout the Operating Instructions. The Sogevac® SV10-16 B **must only be operated in the proper condition and under the conditions described in the Operating Instructions**. It must be operated and maintained by trained personnel only. Consult local, state, and national agencies regarding specific requirements and regulations. Address any further safety, operation and/or maintenance questions to our nearest office.

Failure to observe the following precautions could result in serious personal injury!

SOGEVAC® pumps are not designed:

- for pumping of dusty, aggressive, corrosive, flammable or explosive gases or gases mixtures ;
- for pumping of oxygen or other highly reactive gases with a greater concentration than atmospheric concentration (>20%) ;
- for working in flammable, explosive or dusty environment.

For all these cases, special materials must be used. In case of doubt, please contact Oerlikon Leybold Vacuum.

See also the limits of use indicated in the CE declaration of conformity.

Never expose part of the body to the vacuum. There is a danger of injury. Never operate the pump with an open and thus accessible inlet. Vacuum connections as well as oil filling and oil draining openings must not be opened during operation of the pump.

When operating pump is hot and some surfaces could reach a temperature higher than 80°C (176°F). There is a risk of burn by touching.

Depending on the process involved, dangerous substances and oil may escape from the pump. Take the necessary safety precautions !

When working on the pump system always observe the Operating Instructions.

Warning



Safety Information

Warning



Disconnect the unit from the power supply before starting any work.

Take appropriate precautions to insure that the pump cannot start.

If the pump has pumped hazardous gases it will be absolutely necessary to determine the nature of the hazard involved and take the appropriate safety precautions.

Observe all safety regulations !

Take adequate safety precautions prior to opening the intake or exhaust port.

Caution

Failure to observe the following precautions could result in damage to the equipment!

Liquid and solid particles must not enter the pump. Install the adequate filters, separators and/or condensers. In case of doubt consult Oerlikon Leybold Vacuum.

The intake line of the pump must never be connected to a device with over atmospheric pressure. Design the exhaust line so that no pressure higher than 1,15 bar abs. (0,15 bar rel.) can occur.

Operating of the pump without oil or operating with incorrect direction of rotation can destroy the pump.

Note

Never use discarded seals. Always assemble using new seals.

Respect the instructions concerning environment protection when discarding used oil or exhaust filters !

The pump must be packaged in such a way that it will not be damaged during shipping, and so that no harmful substances can escape from the package.

We reserve the right to alter the design or any data given in these Operating Instructions. The illustrations are not binding.

These installation and operating instructions are valid for the SOGEVAC® pumps SV10-16 B in their standard version.

Special versions to these pumps are delivered with an additive document, which prevails over the standard instructions.

We would be happy to supply further information as required:

Available are :

- Technical description of the SOGEVAC® vacuum pumps
- Technical description of special oil types for SOGEVAC® vacuum pumps
- Breakdown analysis
- Declaration of Contamination of Vacuum Equipment and Components.

1 Description

SOGEVAC® pumps are designed for pumping of inert gases in the range of rough vacuum, between atmospheric pressure and ultimate pressure of the pump.

When pumping condensable vapours, a gas ballast valve must be installed.

1.1 Principle of operation

The SOGEVAC® pumps SV10-16 B are singlestage oil sealed rotary vane vacuum pumps.

The rotor, having three slots in which the vanes are sliding, is eccentrically installed in a pump cylinder (stator). The vanes separate the interior space into 3 chambers. The volume of these chambers varies with the rotation of the rotor. The gas sucked into the inlet chamber is compressed and then pushed out at the exhaust valve.

The oil injected in the inlet chamber guarantees the air-tightness, the lubrication and cooling of the pump. It is dragged off by the compressed gases and roughly separated by gravity when entering in the oil sump. A fine separation is then operated in the exhaust filter. The proportion of oil in the exhaust gas is thus reduced below the visibility threshold (over 99 % entrapment rate). The collected oil is flowing back to the generator through an internal transfer. A non-return valve is included in the oil return screw system to avoid an oil flow from the generator to the oil casing when the pump works at inlet pressures greater than 150 mbar. Therefore, continuous operation above 150 mbar is not recommended and can lead to oil spilling from the exhaust.

Depending on catalog numbers, the pumps are equipped with a gas ballast valve for pumping condensable vapours.

The anti suck back valve at the inlet flange avoids oil coming back into the inlet line when the pump is stopped.

Description

1.2 Technical characteristics

SV10 B

Technical data		50 Hz	60 Hz
Nominal pumping speed ¹⁾	m ³ /h	11	13
Pumping speed ¹⁾ (according to PNEUROPOP)	m ³ /h	9,5	11,5
Ultimate partial pressure without gas ballast ¹⁾	mbar	≤ 1,5	≤ 1,5
Ultimate total pressure with gas ballast ¹⁾	mbar	≤ 2,5	≤ 2,5
Water vapour tolerance ¹⁾	mbar	10	15
Water vapour tolerable load ^{1) 3)}	g.h ⁻¹	20	30
Oil capacity	l	0,5	0,5
Noise level ²⁾	dB (A)	60 (3 φ) 62 (1 φ)	64 (3 φ) 66 (1 φ)
Motor power	kW	0,55	0,65
Motor rated rotational speed	min ⁻¹	3000	3600
Protection – Insolation		IP 55 – F	IP 55 – F
Weight with mineral oil	kg	20	20
Intake connection		G 3/4 + G1/2	G 3/4 + G1/2
Exhaust connection		-	-

SV16 B

Technical data		50 Hz	60 Hz
Nominal pumping speed ¹⁾	m ³ /h	16	19
Pumping speed ¹⁾ (according to PNEUROPOP)	m ³ /h	15	17
Ultimate partial pressure without gas ballast ¹⁾	mbar	≤ 1	≤ 1
Ultimate total pressure with gas ballast ¹⁾	mbar	≤ 2	≤ 2
Water vapour tolerance ¹⁾	mbar	10	15
Water vapour tolerable load ^{1) 3)}	g.h ⁻¹	30	50
Oil capacity	l	0,5	0,5
Noise level ²⁾	dB (A)	60 (3 φ) 62 (1 φ)	64 (3 φ) 66 (1 φ)
Motor power	kW	0,55	0,65
Motor rated rotational speed	min ⁻¹	3000	3600
Protection – Insolation		IP 55 – F	IP 55 – F
Weight with mineral oil	kg	20	20
Intake connection		G 3/4 + G1/2	G 3/4 + G1/2
Exhaust connection		-	-

1) to DIN 28400 and following numbers

2) operated at the ultimate pressure without gas-ballast, free-field measurement at a distance of 1 m

3) with room temperature 20 to 25 ° C

Remark : pump technical data like e.g. ultimate pressure & noise level are only valid for standard pumps operating with the mentioned mineral oil. The use of other oils may have consequences on these values.

Description

SV10-16 B

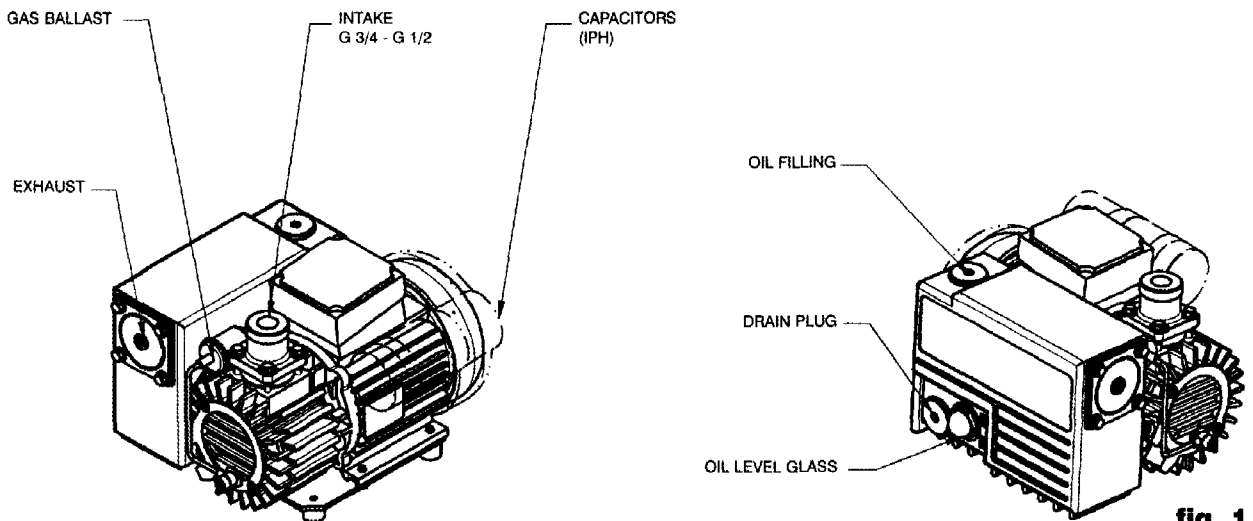
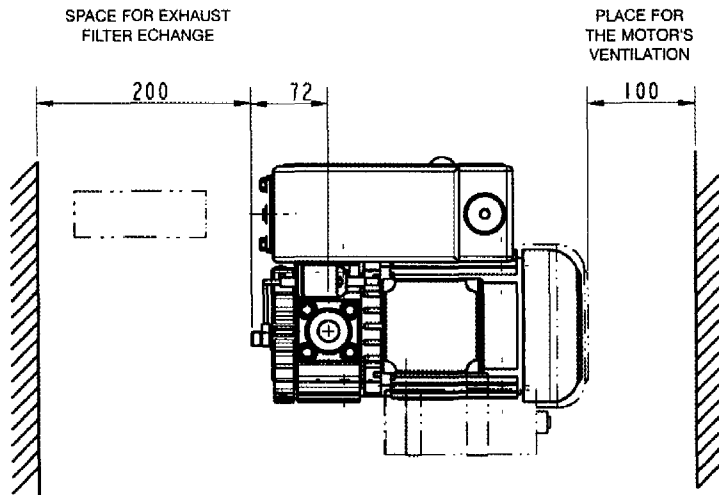
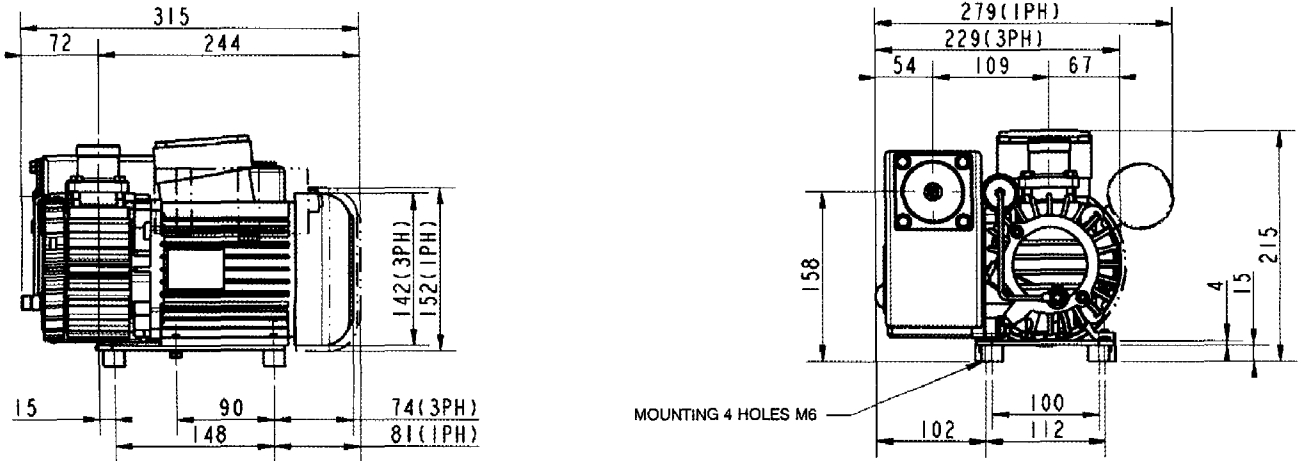

fig. 1

Description

Pumping speeds SV10-16 B

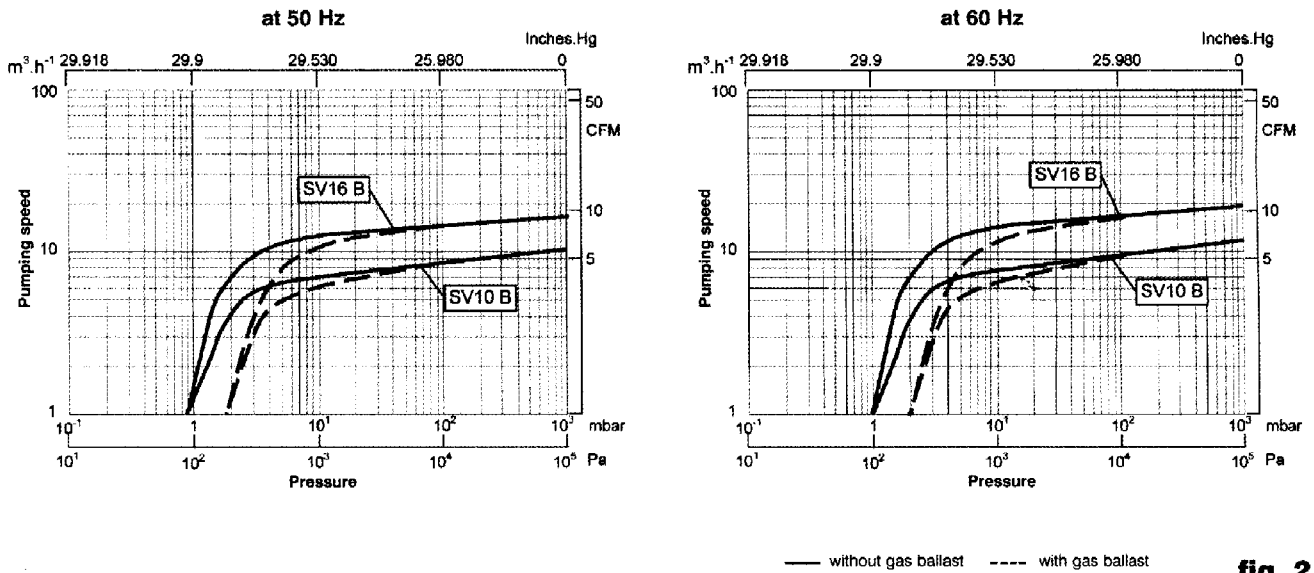

fig. 2

1.3 Connection fittings

Rep.	Specification	Size	Cat. Nr.
1*	REDUCTION + O-RING	G 3/4 M - G 1/2 F	951 24
2	CONNECTING PIECE (THREE PIECES)	G 1/2 MF	711 18 020
3	SCREW IN NIPPLE	G 1/2 M - 16 KF	711 18 120
4	CENTERING RING	DN 16 KF	183 26
5	CLAMPING RING	DN 16 KF	183 41
6	HOSE CONNECTION	DN 16 KF - 25 mm	711 18 300
7	HOSE CONNECTION	G 1/2 M - 25 mm	711 18 011
8	PVC TUBING	25 mm	711 18 323
9	T-PIECE	G 1/2 M-F-F	711 18 250
10	VACUUM CONTROL VALVE	G 1/2 M	951 86
11	VACUUM CONTROL VALVE WITH SHUT-OFF VALVE	G 1/2 M	951 87
12	BALL VALVE	G 1/2 M/F	711 30 113
13	SPRING VACUUM METER	G 1/2 M	951 92
14	ELBOW 90°	G 1/2 M/F	711 18 210
15	DUST FILTER PAPER	G 1/2 M/F	951 50
	DUST FILTER CHARCOAL	G 1/2 M/F	711 27 092
	DUST FILTER METAL	G 1/2 M/F	711 27 093
	DUST FILTER POLYESTER	G 1/2 M/F	711 27 094
	EXHAUST CONNECTION	G 3/4 F	9 714 33 140

* Delivered with the pump depending on pump cat no.

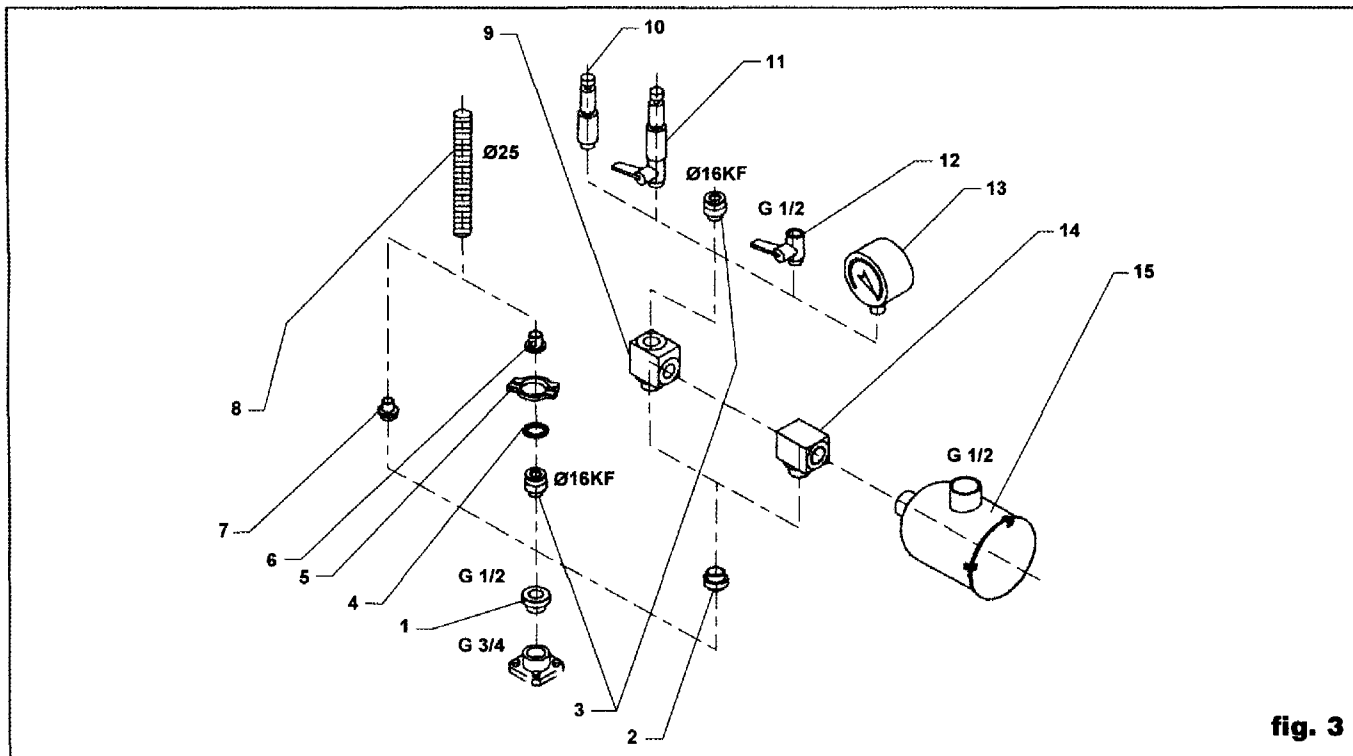

fig. 3

1.4 Spare parts

Specification	Cat. Nr.
SET OF SEALS	714 22 220
REPAIR KIT	714 22 230
SERVICE KIT	9 714 44 430
INLET FILTER ELEMENT FOR FILTER POS. (15)	
FILTER ELEMENT PAPER	710 40 762
FILTER ELEMENT CHARCOAL	710 65 713
FILTER ELEMENT METAL	710 65 813
FILTER ELEMENT POLYESTER	712 61 280

1.5 Lubricants

The SOGEVAC® SV10-16 B pumps should be run with mineral oils for vacuum pumps with low viscosity according to ISO category VG32. The Oerlikon Leybold Vacuum oil GS32 corresponds to these prescriptions.

GS32 Oil :	Conditioning	Reference
	0,5 l	711 17 721
	1 l	711 17 772
	2 l	9 711 17 723
	5 l	711 17 724
	20 l	711 17 725

You may use other special lubricants adapted to the applications. Please consult us.

Transport and Storing

2 Transport and storing

2.1 Transport and packing

SOGEVAC® vacuum pumps pass a rigorous operating test in our factory and are packed to avoid transport damage.

Please check packing on delivery for transport damage.

Packing materials should be disposed off according to environmental laws or re-used.

These operating instructions are part of the consignment.

The connection ports are blanked off by plastic protective caps or self-adhesives. Take these caps or self-adhesives away before turning on the pump.

The necessary GS32 oil is shipped in a separate can.

2.2 Mounting orientation

See required space on chart in paragraph 1.2.

Pumps which have been filled with oil must only be moved in the upright position (horizontally). Otherwise oil may escape. The angle of slope may not be over 10° max. Avoid any other orientations while moving the pump.

2.3 Storage

Before stocking the pump for a long time put it back in its original condition (blank off inlet and exhaust ports with the shipping seals, drain the oil sump) and store the pump in a dry place at room temperature.

If the pump has been shelved for over one year, standard maintenance must be run and the oil must be exchanged too before the pump is put in to service once more. We recommend that you contact the service from Oerlikon Leybold Vacuum.

3 Installation

It is essential to observe the following instructions step by step to ensure safe start-up. Start-up may only be conducted by trained specialists.

Observe all safety regulations.

3.1 Setting-up

The pump must be set up or mounted horizontally on a flat surface. Special mounting is not required.

The following ambient operating environment must be observed:

- Ambient temperature: 12 °C to 40 °C (54 °F to 104 °F)
- Ambient pressure: Atmospheric pressure. Max. altitude 1000 m absl.

In order to avoid over-heating of the pump, an undisturbed fresh airflow to the pump is necessary.

3.2 Inlet connection

See safety information page 3.

The inlet flange can be connected with a vacuum-tight flexible hose and/or pipe.

The pipes should cause no stresses on the pump's flanges. If necessary, compensators must be installed.

Restriction of the pipes must be avoided in order not to decrease the pumping speed of the pump. The nominal diameter of the pipes has to be least the same as the diameter of pump's inlet flange.

When pumping condensable vapours, a gas ballast valve must be installed.

3.3 Connection to exhaust side

No isolation or restricting devices should be installed in the exhaust line of the pump.

If an exhaust line is installed, it must at least have the same diameter as the exhaust flange. It should be installed in a manner so that no condensate can enter the pump (siphon, slope).

Warning: The maximum exhaust pressure must neither exceed 1.15 bar absolute (0.15 bar relative), nor fall under atmosphere pressure minus 15 mbar

3.4 Oil filling

See safety information page 3.

The necessary GS32 oil is supplied in a can beside the pump. To fill in the oil, unscrew the oil fill plug and fill in until the oil level reaches the MAX-mark beside the oil sight glass.

Warning



Caution

Note

Caution

Installation

Warning



3.5 Electrical connection

See safety information page 3

The electrical installation may only be conducted by a specialist. IEC regulations have to be followed as well as local or country regulations.

- Voltage and frequency mentioned on the motor nameplate must agree with the supply voltage.
 - The drive motor must be protected against overloads according to IEC 60204-1.
 - To check the direction of rotation of pumps with three-phase motor, flick the ON/OFF switch for a short time at atmospheric pressure. If the direction of rotation is not identical with the one indicated by the arrow sticking on the motor hood, then inverse any two of the electrical phases in the terminal box. Looking at the motor fan cover, the direction of rotation has to be counter-clockwise.
-

4 Operation

4.1 Operating advices

See safety information page 3.

When removing condensable vapours, a gas ballast valve must be installed.

The vacuum pump must be run for 30 minutes before operating with condensable vapours with the inlet connection closed, in order to reach the operating temperature of about 75 °C. Only up from this operating temperature, condensable vapours can be pumped. After use, the pump has to be left running for an additional 30 minutes with the inlet connection closed, to clear the oil of condensate.

4.2 Shutdown

The inlet flange of the SOGEVAC® pumps contains an anti-suck back valve. It closes the inlet flange when the pump is voluntarily or accidentally shut down, thus maintaining the vacuum in the connected system and preventing oil from being sucked back into the system.

Except the indications in chapter 4.1 (operating advices) there are no particular precautions for the shutdown of the pump.

If the pump must be stopped for a longer period, see chapter 2.3.

Caution

Maintenance

Warning



5 Maintenance

5.1 Safety Information

Observe all safety regulations.

The vacuum pump must be switched off and secured against accidental switch-on for all maintenance jobs.

All work must be done by suitably trained personnel. Maintenance or repairs carried out incorrectly will affect the life and performance of the pump and may cause problems when filing warranty claims.

Never mount used seals ; always mount new seals ^{**}

5.2 Maintenance Intervals

The intervals stated in the maintenance schedule are approximate values for normal pump operation. Unfavourable ambient conditions and/or aggressive media may significantly reduce the maintenance intervals.

Maintenance job	Frequency	Section
Oil level checking	Daily	A
1st oil change	After 150 h of operation	B
Subsequent oil changes	Every 2000 h or 6 months (depending on application)	B
Exhaust filter	If oil mist at ex-haust replacement or annually	C
Checking the oil recovery system		D
Gas ballast valve	Monthly checking	E
Inlet flange sifter cleaning	6 months	F
Anti-suck back valve checking	6 months	G
Fan cover cleaning	6 months	H
Electrical connection checking (only by a specialist)	6 months	

In order to simplify the maintenance work we recommend to combine several jobs.

5.3 Oerlikon Leybold Vacuum Service

Whenever you send us in equipment, indicate whether the equipment is contaminated or is free of substances which could pose a health hazard. If it is contaminated, specify exactly which substances are involved. You must use the form we have prepared for this purpose.

A copy of the form has been reproduced at the end of these Operating Instructions: "Declaration of Contamination for Compressors, Vacuum Pumps and Components". Another suitable form is available from www.oerlikon.com → Oerlikon Leybold Vacuum Systems → Documentation → Download Documents.

Attach the form to the equipment or enclose it with the equipment.

This statement detailing the type of contamination is required to satisfy legal requirements and for the protection of our employees.

We must return to the sender any equipment which is not accompanied by a contamination statement.

The pump must be packaged in such a way that it will not be damaged during shipping, and so that no harmful substances can escape from the package.

When disposing of used oil, please observe the relevant environmental regulations.

5.4 Maintenance Work

A. Oil level

The oil level should be checked at least once a day. If the oil level is below the "MAX" mark, oil has to be added until the level reaches the mark. If the oil level is below the "MIN" mark, stop the pump and check it (see chapter 6).

B. Oil changing

See safety information page 3.

Oil must be changed after the first 150 operating hours. Further oil changes, depending on operating conditions (products, vapours, ambient temperature...) must be done every 500 to 1500 operating hours or at least every 6 months.

If there is considerable pollution, it could be necessary to change the oil more frequently.

Oil changing must be done with a switched off and still warm pump.

Open the oil drain plug and let run out the used oil into an appropriate container. Refasten the oil drain plug when oil runs slower, start up the pump briefly (5 sec. max) and switch off immediately. Reopen the oil drain plug and drain the rest of the oil. Before refastening the oil drain plug, inspect the O-ring and if necessary replace it. Open the oil fill plug and pour in clean oil ; refasten the oil fill plug. The pump has to be rinsed out if there is considerable pollution. Therefore pour in clean oil up to the low edge of the oillevel glass, let the pump run briefly (for a few minutes) then drain the oil again.

Contamination

Form

Caution

Warning



Maintenance

Caution**C. Exhaust filters replacement**

See safety information page 3.

Oil mist escaping from the exhaust during operation indicates that the filter is probably choked up. Increased motor current could also be the result of a dirty exhaust filter. Open the exhaust hood, take out the filter and replace it. Also check the gasket of the exhaust flange and change it if necessary.

Caution**D. Checking the oil recovery system**

See safety information page 3.

During the exchange of the exhaust filter, check the cleanliness of the foam which protects the oil return compartment and the oil recovery system. Disassemble the oil return screw system from the end plate and check the cleanliness of the nozzle (without disassembling it from the unit). In case of heavy dirtiness, replace the whole oil recovery screw system.

Caution**E. Gas ballast valve cleaning**

See safety information page 3.

If the filter of the gas ballast valve is dirty, the gas ballast is no longer operative. The filter has to be replaced (see spare parts list).

Caution**F. Inlet flange sifter cleaning**

See safety information page 3.

To clean the inlet flange screen, disconnect the inlet flange and clean the screen with blast air or an appropriate solvent.

Caution**G. Anti-suck back valve checking**

See safety information page 3.

The anti suck-back valve should be checked at the same time as the inlet flange screen and if dirty, be cleaned with an appropriate solvent. Also check, if there is no damage on the sealing part of the valve.

H. Fan cover cleaning

Dirt blockage of the fan cover may lead to overheating of the motor and the pump. Put off the cover and clean it with blast air. Before starting the pump again, be sure that the cover has been reassembled.

6 Troubleshooting

If you have a breakdown, please contact the Oerlikon Leybold Vacuum service station and/or ask us, to send you the guide: "Problem Analysis".

Spare parts

7 Spare parts

To guarantee safe operation of the Oerlikon Leybold Vacuum vacuum pump, only original spare parts and accessories should be used. When ordering spare parts and accessories, always state pump type and serial number. You can find part numbers in the spare parts list.

Consummables and main spare parts kits for SOGEVAC® pumps are usually available on stock at Oerlikon Leybold Vacuum's service centers. The list of these parts is given here after and in the spare parts table where the contents of each kits is detailed.

- Exhaust demisters 714 13 280
- Oil GS 32 (Special oils please refer to the specific notice of the pump or contact Oerlikon Leybold Vacuum).
- Service kit 9 714 44 430
- Set of seals 714 22 220
- Repair kit 714 22 230

We recommend to use these kits which have been defined to allow an optimal maintenance or repair. individual spare parts may need longer delivery time.

Repairs requiring the replacement of the stator or the rear endplate should be made by the Oerlikon Leybold Vacuum Service.

Spare parts

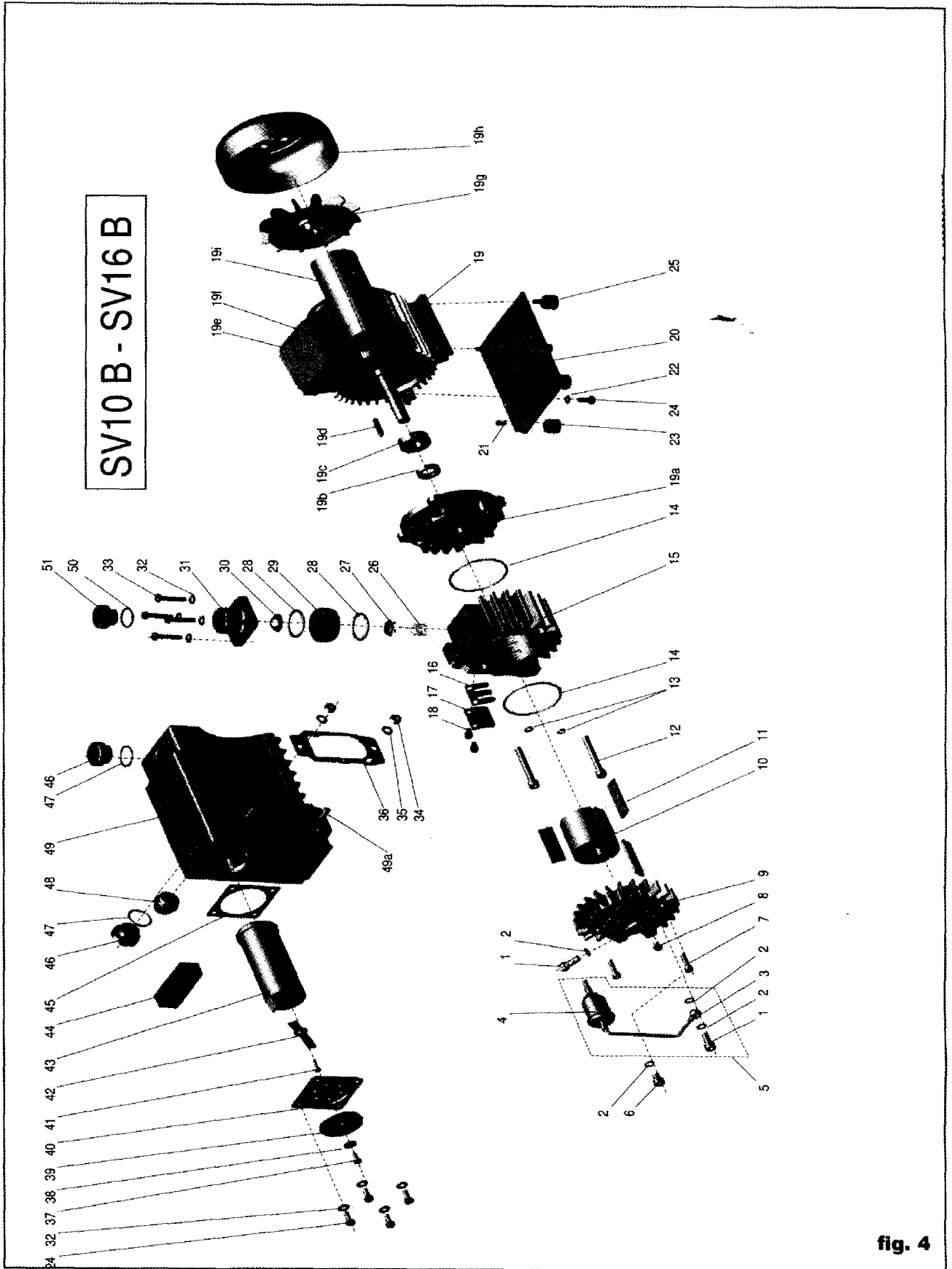

fig. 4

ERSATZTEILLISTE / SPARES LIST / LISTE DES PIECES DE RECHANGE SV10 B / SV16 B									
POS	Stück Qty	BENENNUNG	SPECIFICATION	DESIGNATION	Abmessungen (mm), Werkstoff Dimensions (mm), Material Dimensions (mm), matière	Bestell-Nr Ref. No. N° de Réf.	Remarques		
1	2	RÜCKSICHERUNGSSCHRAUBE	NON RETURN SCREW UNIT	VIS ANTI-RETOUR ENS.		71416500		●	
2	3	FLACHDICHTUNG	FLAT GASKET	JOINT PLAT	8,5X12X1 CU	71413460		●	
3	1	GB LEITUNG EINHEIT	G-B PIPE UNIT	CANALISATION L-A ENS.		71415000			
4	1	FILTER VK31/2	FILTER VK 31/2	FILTRE VK 31/2		71414970		● ●	
5	1	GB LEITUNG + FILTER	G-B PIPE + FILTER	CANALISATION L-A+FILTRE		71415330	Incl.1,2,3,4		
6	1	SCHRAUBE	SCREW	VIS	CHC M8X10 Q8.8 ZN	71417620	Incl.2		
7	2	SCHRAUBE	SCREW	VIS	CHC M6 X 25 Q8.8 ZC	V3811415			
8	1	SCHRAUBE	SCREW	VIS	HM6X8 Q6.8 ZC	V3802402			
9	1	LAGERDECKEL	FRONT END-PLATE	FLASQUE AVANT		71416460	Incl.8		
10	1	ANKER	ROTOR	ROTOR		71413100			
11	1	SATZ 3 SCHIEBER	SET 3 VANES	JEU DE 3 PALETTES		71413150		●	
12	2	SCHRAUBE	SCREW	VIS	CHC M8 X 65 Q8.8	V3810531			
13	2	O-RING	O-RING	JOINT TOR	6,02 X 2,62 70SH FKM	71237600		●	
14	2	O-RING	O-RING	JOINT TOR	70 X 2,5 70SH NBR	71413470		●	
15	1	PUMPENRING SV10 B	PUMP CYLINDER SV10 B	STATOR SV10 B		71418380			
15	1	PUMPENRING SV16 B	PUMP CYLINDER SV16 B	STATOR SV16 B		71416450			
16	1	VENTILPLATTE	VALVE PLATE	LAME		71416370		●	
17	1	VENTILANSCHLAG	VALVE STOP	CONTRE LAME		71416380		●	
18	2	SCHRAUBE	SCREW	VIS	CHC M6X10 Q8.8	V3811405			
19	1	VOIR PAGE SUIVANTE / SEE NEXT PAGE / SEIHE ANDERE SEITE							
20	1	PLATTE	SUPPORTING PLATE	TOLE SUPPORT		71415300			
21	2	SCHRAUBE	SCREW	VIS	HC M6 X 12 Q8.8 ZC	71418660			
22	2	SCHEIBE	WASHER	RONDELLE	W6	V3600425			
23	2	GUMMIFUSS	RUBBER MOUNT	AMORTISSEUR	D20X15 F-F M6	71418670			
24	6	SCHRAUBE	SCREW	VIS	HM6X16 Q6.8 ZC	V3802411			
25	2	GUMMIFUSS	RUBBER MOUNT	AMORTISSEUR	D20X15	71414030			
26	1	SAUGSTUTZEN FEDER	INLET SPRING	RESSORT ASPIRATION		71415640			
27	1	ANSAUGVENTIL	ANTI SUCKBACK VALVE	CLAPET ASPIRATION		71042990		●	
28	2	O-RING	O-RING	JOINT TOR	34.52X3.53 70SH FKM	71417660		●	
29	1	ANSAUGZWISCHENSTÜCK	INLET ADAPTER	ENTRETOISE ASPIRATION		71413110			
30	1	SAUGSTUTZEN FILTER	DIRT TRAP	FILTRE EMBOUTI ASPIRATION		71413440			
31	1	ANSAUGFLANSCH	INLET FLANGE	BRIDE ASPIRATION		71413120			
32	8	SCHEIBE	WASHER	RONDELLE	M6 ZC	V3600401			
33	4	SCHRAUBE	SCREW	VIS	HM6X35 Q6.8	V3802419			
34	2	MUTTER	NUT	ECROU	HM8 Q6 ZC	V1500501			
35	2	SCHEIBE	WASHER	RONDELLE	W8 ZC	V3600524			
36	1	FLACHDICHTUNG	FLAT GASKET	JOINT CARTER STATOR		71416430		●	
37	1	BLECHSCHRAUBE	SHEET METAL SCREW	VIS A TOLE	CL N 10-19 TYPE P	V3835710			
38	1	SCHEIBE	WASHER	RONDELLE	L5 ZC	V3600305			
39	1	AUSPUFFMEMBRANE	EXHAUST MEMBRANE	MEMBRANE D'ECHAPPEMENT		71413170			
40	1	AUSPUFFFLANSCH	FLANGE EXHAUST	BRIDE REFOULEMENT		71413160			
41	1	SCHRAUBE	SCREW	VIS	C M4X16 Q5.6 CRV ZN	V3827310			
42	1	AUSPUFF FILTER FEDERBLATT	FRICTION SPRING CARTRIDGE	LAME RESSORT CARTOUCHE ENS		71413270		● ●	
43	1	AUSPUFF-FILTER	EXHAUST FILTER	CARTOUCHE		71413280		● ●	
44	1	ÖLRÜCKFÜHRUNGSFILTER	OIL RETURN FILTER	FILTRE RECUPERATION		71416440		● ●	
45	1	FLACHDICHTUNG AUSLASS	FLAT GASKET OUTLET	JOINT REFOULEMENT		71413240		● ●	
46	2	STOPFEN+ O-RING	PLUG + O-RING	BOUCHON FENDU-	G3/4	71256380	Incl.47		
47	2	O-RING	O-RING	JOINT TOR	27 X 2,5 NBR	71036720		● ●	
48	1	OELSCHAUGLAS	OIL SIGHT GLASS	VOYANT D'HUILE	G3/4	71212420		●	
49	1	OELKASTEN	OIL CASING	CARTER D'HUILE		71416410	Incl.49a		
49a	2	BOLZEN	LOCKING SCREW	GOUJON	M8-25/15,=12 Q6.8	V2100425			
50	1	O-RING	O-RING	JOINT TOR	28 X 3 FKM	71217590		●	
51	1	REDUZIERSTÜCK + O-RING	REDUCTION + O-RING	REDUCTION + JOINT	G 3/4-G 1/2	95124			
		DICHTUNGSSATZ	SET OF SEALS	JEU DE JOINTS		71422220	Incl. _____	▲ ▲	
		REPARATUR KIT	REPAIR KIT	KIT REPARATION		71422230	Incl. _____	▲ ▲	
		WARTUNGSSATZ	SERVICE KIT	KIT DE MAINTENANCE		971444430	Incl. _____	▲ ▲	

Spare parts

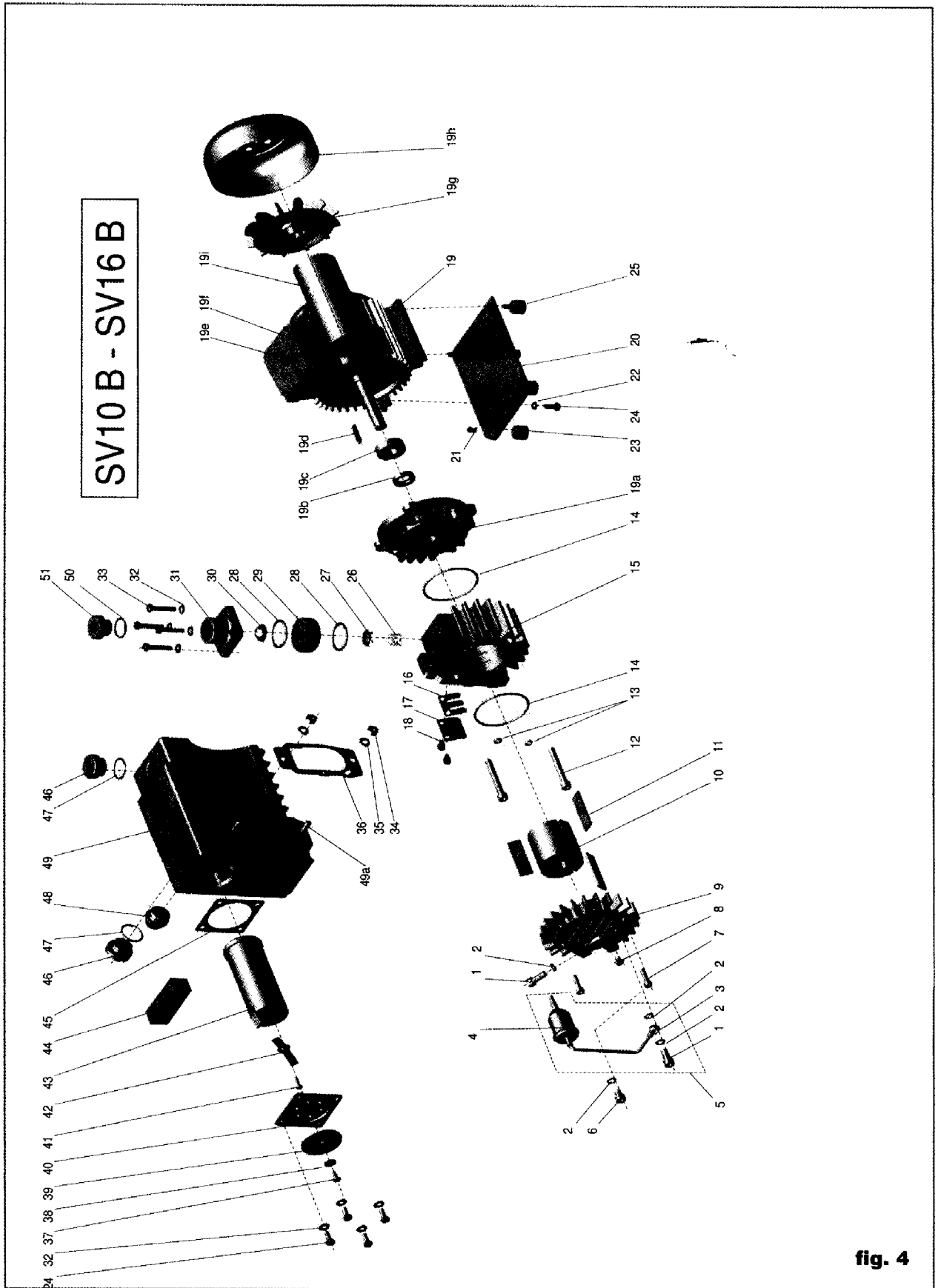

fig. 4

POS	Stück Qty	BENENNUNG	SPECIFICATION	DESIGNATION	Abmessungen (mm), Werkstoff Dimensions (mm), Material matière	Bestell-Nr Ref. No. N° de Ref.	Remarques			
19	1	MOTOR EUR / USA 3PH	MOTOR EUR / USA 3PH	MOTEUR EUR / USA 3PH	0,55 kW à 50 Hz / 0,65 kW à 60 Hz 220 - 240 / 380 - 415 V+ - 10 %; 50 Hz 220 - 266 / 380 - 460 V+ - 10 %; 60 Hz	71415050	Incl.19a,b,c,d,e,f,g,h			
19a	1	HINTEREN LAGERDECKEL	END BEARING PLATE	FLASQUE ARRIERE		71413490				
19b	1	RADIAL DICHTUNG	RADIAL SHAFT SEAL	JOINT A LEVRE	DN17X30X6	71421560	*	●		
19c	1	KUGELLAGER	BALL BEARING	ROULEMENT	DN17X40X12	71421550				
19d	1	PASS-FEDER	KEY	CLAVETTE	5X5X30	71415200				
19e	1	KLEMMENKASTEN	TERMINAL BOX	BOITE A BORNES		971444340				
19f	1	KLEMMENBRETT	TERMINAL BOARD	BORNIER		71422210				
19g	1	LUEFTER	FAN	VENTILATEUR MOTEUR		71421530				
19h	1	LUEFTERHAUBE	FAN COVER	CAPOT MOTEUR		71421540				
19	1	MOTOR JAPAN 3PH	MOTOR JAPAN 3PH	MOTEUR JAPON 3PH	0,55 kW à 50 Hz / 0,65 kW à 60 Hz 200 V+ 10 % - 15 %; 50 & 60 Hz	71415070	Incl.19a,b,c,d,e,f,g,h			
19e	1	KLEMMENKASTEN	TERMINAL BOX	BOITE A BORNES		971444410				
19f	1	KLEMMENBRETT	TERMINAL BOARD	BORNIER		71422210				
19g	1	LUEFTER	FAN	VENTILATEUR MOTEUR		71421530				
19h	1	LUEFTERHAUBE	FAN COVER	CAPOT MOTEUR		71421540				
19	1	MOTOR EUR / USA 3PH CCC	MOTOR EUR / USA 3PH CCC	MOTEUR EUR / USA 3PH CCC	0,55 kW à 50 Hz / 0,65 kW à 60 Hz 220 - 240 / 380 - 415 V+ - 10 %; 50 Hz 220 - 266 / 380 - 460 V+ - 10 %; 60 Hz	971451240	Incl.19a,b,c,d,e,f,g,h			
19e	1	KLEMMENKASTEN	TERMINAL BOX	BOITE A BORNES		971444340				
19f	1	KLEMMENBRETT	TERMINAL BOARD	BORNIER		71422210				
19g	1	LUEFTER	FAN	VENTILATEUR MOTEUR		71421530				
19h	1	LUEFTERHAUBE	FAN COVER	CAPOT MOTEUR		71421540				
19	1	MOTOR EUR 1PH	MOTOR EUR 1PH	MOTEUR EUR 1PH	0,55 kW à 50 Hz / 0,65 kW à 60 Hz 230 V+ - 10 %; 50 & 60 Hz	71413770	Incl.19a,b,c,d,e,f,g,h,i			
19e	1	KLEMMENKASTEN	TERMINAL BOX	BOITE A BORNES		971444380				
19f	1	KLEMMENBRETT	TERMINAL BOARD	BORNIER		971444350				
19g	1	LUEFTER	FAN	VENTILATEUR MOTEUR		971444360				
19h	1	LUEFTERHAUBE	FAN COVER	CAPOT MOTEUR		971444370				
19i	1	KONDENSATOR	CAPACITOR	CONDENSATEUR	16 µF	971444390				
19	1	MOTOR USA 1PH	MOTOR USA 1PH	MOTEUR USA 1PH	0,65 kW à 60 Hz 110 - 120 V+ - 10 %; 60 Hz	71413940	Incl.19a,b,c,d,e,g,f,h,i			
19e	1	KLEMMENKASTEN	TERMINAL BOX	BOITE A BORNES		971444410				
19f	1	KLEMMENBRETT	TERMINAL BOARD	BORNIER		971444350				
19g	1	LUEFTER	FAN	VENTILATEUR MOTEUR		971444360				
19h	1	LUEFTERHAUBE	FAN COVER	CAPOT MOTEUR		971444370				
19i	1	KONDENSATOR	CAPACITOR	CONDENSATEUR	110 µF	971444400				
19	1	MOTOR JAPAN 1PH	MOTOR JAPAN 1PH	MOTEUR JAPON 1PH	0,55 kW à 50 Hz / 0,65 kW à 60 Hz 100 V+ 10 % - 15 %; 50 & 60 Hz	71415040	Incl.19a,b,c,d,e,f,g,h,i			
19e	1	KLEMMENKASTEN	TERMINAL BOX	BOITE A BORNES		971444410				
19f	1	KLEMMENBRETT	TERMINAL BOARD	BORNIER		971444350				
19g	1	LUEFTER	FAN	VENTILATEUR MOTEUR		971444360				
19h	1	LUEFTERHAUBE	FAN COVER	CAPOT MOTEUR		971444370				
19i	1	KONDENSATOR	CAPACITOR	CONDENSATEUR	110 µF	971444400				
19	1	MOTOR EUR 1PH CCC	MOTOR EUR 1PH CCC	MOTEUR EUR 1PH CCC	0,55 kW à 50 Hz / 0,65 kW à 60 Hz 230 V+ - 10 %; 50 & 60 Hz	971451230	Incl.19a,b,c,d,e,f,g,h,i			
19e	1	KLEMMENKASTEN	TERMINAL BOX	BOITE A BORNES		971444380				
19f	1	KLEMMENBRETT	TERMINAL BOARD	BORNIER		971444350				
19g	1	LUEFTER	FAN	VENTILATEUR MOTEUR		971444360				
19h	1	LUEFTERHAUBE	FAN COVER	CAPOT MOTEUR		971444370				
19i	1	KONDENSATOR	CAPACITOR	CONDENSATEUR	16 µF	E6500533				
		DICHTUNGSSATZ	SET OF SEALS	JEU DE JOINTS		71422220	Incl. _____			

- * Immer das Kugellager wechseln, wenn der Wellendichtring ausgetauscht wird.
- * Always change the ball bearing when changing the shaft seal.
- * Remplacer obligatoirement le roulement lors du remplacement du joint à lèvres.