

# DCM-M1

## SERVICE MANUAL

Ver 1.1 2000.03  
With SUPPLEMENT-1  
(9-927-635-81)

US Model  
Canadian Model  
E Model



Video MD

InfoLITHIUM L



Lens Section	Model Name Using Similar Mechanism	NEW
	Mechanism Type	CT-DCMM1-164
MD Section	Model Name Using Similar Mechanism	NEW
	Mechanism Type	MT-DCMM1-163

### SPECIFICATIONS

#### Camcorder

#### System

**System**  
MiniDisc digital AV system

**Video signal**  
NTSC color, EIA standards

**Viewfinder**  
Electric viewfinder (color)

**Image device**  
1/4 inch CCD (Charge Coupled Device)  
Approx. 680,000 pixels  
(Effective: Approx. 340,000 pixels)

**Lens**  
Combined power zoom lens  
Filter diameter 30 mm.  
10x (Optical), 40x (Digital)

**Focal length**  
3.3 - 33 mm  
When converted to a 35 mm still camera: 42 - 420 mm

**Color temperature**  
Auto, HOLD (Hold), Indoor (3200K), Outdoor (5800K)

**Minimum illumination**  
11 lux (F 1.7)

**Illumination range**  
11 to 100,000 lux

**Recommended illumination**  
100 lux or more

**Data compression format**  
Video: MPEG2  
Audio: ATRAC

#### Image data format

In conformity with Video MD  
Main image: 704x480  
Index image: 176x112

**Usable disc**  
MD DATA2 disc (record and play)

**Audio MD (play only)**  
**Recording/playback time**  
To record movie using MD DATA2:  
SP: 10 min.  
VP: 13 to 20 min.  
LP: 20 min.  
Interview (audio) recording:  
Max. 260 min.  
To play audio MD  
Max. 160 min. using MDW-80 recorded in monaural  
Max. 80 min. using MDW-80 recorded in stereo

**Recordable still pictures**  
Max. 4500 tracks (MPEG 2 Intra-Picture adopted)

#### Recording system

Laser strobing magnetic

modulation system

Reading system

Non-contact optical reading (semiconductor laser used)

#### Laser diode properties

Material: AlGaInP  
NA = 0.52  
Wavelength: 655 nm  
Emission duration: Continuous  
Laser output: less than 1000  $\mu$ W  
(This output is the value measured at a distance of about 200 mm from the objective lens surface on the optical pickup block with 7 mm aperture.)

**Error correction**  
Using MD DATA2:  
Reed Solomon Product Code (RSPC)  
Using audio MD:  
Advanced Cross Interleave Reed Solomon Code (ACIRC)

**Modulation system**  
Using MD DATA2:  
DC component suppressed RLL (1.7) (DRL)  
Using audio MD:  
EFM

#### Audio

**Channel**  
Stereo 2 channels

**Sampling frequency**  
44.1 kHz

#### Frequency response

20 to 20,000 Hz +/−3 dB  
**Wow and flutter**  
Below measurable limit

#### Input/Output connectors

**S video output**  
4-pin mini DIN (1)  
Luminance signal: 1 Vp-p, 75 ohms, unbalanced  
Chrominance signal: 0.286 Vp-p, 75 ohms, unbalanced

**Audio/Video output**  
AV MINI JACK (1)  
Video: 1 Vp-p, 75 ohms, unbalanced, sync negative  
Audio: 194 mV at 10 kilohms load impedance

**Headphones jack**  
Stereo minijack (ø 3.5 mm) (1)

**MIC jack**  
Stereo minijack (ø 3.5 mm) (1)  
0.388 mV low impedance with 2.4 V DC, input impedance 6.8 kilohms

**REMOTE jack**  
Stereo mini-mini jack (ø 2.5 mm) (1)

— Continued on next page —



## MINIDISC AV RECORDER



# SONY®

**LINE IN jack (audio)**  
 (supplied connecting cord)  
 Stereo mini jack (ø 3.5 mm) (1)  
 194 mV, input impedance 47  
 kilohms or more  
**10BASE-T jack**  
 (supplied connecting cord)  
 8-pin modular jack (1)

**LCD screen**

**Touch panel**  
**Picture**  
 3.5 inches measured diagonally  
 2 7/8 x 2 inches (72.4 x 50.4 mm)  
**LCD panel**  
**TFT drive**  
**Total dot number**  
 184,580 (839 x 220)

**General**

**Power requirements**  
 7.2 V (battery pack)  
**Average power consumption**  
 During camera recording using  
 viewfinder (SP mode)  
 7.0 W  
 During camera recording using  
 LCD (SP mode)  
 8.0 W  
 Playback when connected using  
 AVconnecting cable (SP mode/  
 LCD on)  
 6.5 W  
**Operating temperature**  
 32°F to 104°F (0°C to 40°C)  
**Storage temperature**  
 -4°F to +140°F (-20°C to +60°C)  
**Dimensions (approx.)**  
 2 19/32 x 4 3/8 x 4 21/32 inches  
 (74 x 111 x 118 mm) (w/h/d)

**Mass (approx.)**  
 1 lb 8 oz (680 g)  
 main unit only  
 1 lb 11.8 oz (790 g)  
 including NP-F550 battery pack  
 and MD DATA2 disc

**Microphone**  
 Stereo electret condenser  
 microphone

**Speaker**

Dynamic

**Supplied accessories**

- ① AC-VQ800 AC adaptor/charger (1)
- ② AC power cord (1)
- ③ MMD-650A MD DATA2 disc (1)
- ④ ZK-ET1 connecting cord (1)
- ⑤ NP-F550 battery pack (1)
- ⑥ RMT-DCM1 Wireless Remote  
Commander (1)
- ⑦ Size AA (R6) battery for Remote  
Commander (2)
- ⑧ Input pen (1)
- ⑨ Tripod attachment (1)
- ⑩ A/V connecting cable (1)
- ⑪ Lens cap (1)
- ⑫ Ferrite cores (large x1, small x2)
- ⑬ Shoulder belt

**AC adaptor/  
 charger AC-VQ800**

**Power requirements**

100 - 240 V AC, 50/60 Hz

**Power consumption**

25 W

Charge mode: 35 VA (100 V AC),  
 50 VA (240 V AC)

Operating mode: 40 VA (100 V  
 AC), 50 VA (240 V AC)

**Output voltage**

DC OUT: 8.4 V, 2.0 A in operating  
 mode

**Battery charge terminal: 8.4 V, 1.4  
 A in charge mode**

**Operating temperature**  
 32°F to 104°F (0°C to 40°C)

**Storage temperature**  
 -4°F to +140°F (-20°C to +60°C)

**Dimensions**

Approx. 5 1/3 x 1 10/16 x 3 1/2  
 inches (136 x 48 x 90 mm) (w/h/  
 d)

**Mass**  
 Approx. 8.8 oz (250 g)

**Battery pack  
 NP-F550**

**Type**

Lithium ion

**Output voltage**

DC 7.2 V

**Capacity**

10.8 Wh

**Dimensions (approx.)**

1 9/16 x 13/16 x 2 7/8 inches

(38.4 x 20.6 x 70.8 mm) (w/h/  
 Mass (approx.)

3.4 oz (95 g)

Design and specifications are  
 subject to change without noti

**SAFETY-RELATED COMPONENT WARNING!!**

COMPONENTS IDENTIFIED BY MARK  $\triangle$  OR DOTTED  
 LINE WITH MARK  $\triangle$  ON THE SCHEMATIC DIAGRAMS  
 AND IN THE PARTS LIST ARE CRITICAL TO SAFE  
 OPERATION. REPLACE THESE COMPONENTS WITH  
 SONY PARTS WHOSE PART NUMBERS APPEAR AS  
 SHOWN IN THIS MANUAL OR IN SUPPLEMENTS PUB-  
 LISHED BY SONY.

**ATTENTION AU COMPOSANT AYANT RAPPORT  
 À LA SÉCURITÉ!**

LES COMPOSANTS IDENTIFIÉS PAR UNE MARQUE  $\triangle$   
 SUR LES DIAGRAMMES SCHÉMATIQUES ET LA LISTE  
 DES PIÈCES SONT CRITIQUES POUR LA SÉCURITÉ  
 DE FONCTIONNEMENT. NE REMPLACER CES COM-  
 POSANTS QUE PAR DES PIÈCES SONY DONT LES  
 NUMÉROS SONT DONNÉS DANS CE MANUEL OU  
 DANS LES SUPPLÉMENTS PUBLIÉS PAR SONY.

**SAFETY CHECK-OUT**

After correcting the original service problem, perform the following  
 safety checks before releasing the set to the customer.

1. Check the area of your repair for unsoldered or poorly-sol-  
 dered connections. Check the entire board surface for solder  
 splashes and bridges.
2. Check the interboard wiring to ensure that no wires are  
 "pinched" or contact high-wattage resistors.
3. Look for unauthorized replacement parts, particularly transis-  
 tors, that were installed during a previous repair. Point them  
 out to the customer and recommend their replacement.
4. Look for parts which, though functioning, show obvious signs  
 of deterioration. Point them out to the customer and recom-  
 mend their replacement.
5. Check the B+ voltage to see it is at the values specified.
6. Flexible Circuit Board Repairing
  - Keep the temperature of the soldering iron around 270 °C  
 during repairing.
  - Do not touch the soldering iron on the same conductor of  
 the circuit board (within 3 times).
  - Be careful not to apply force on the conductor when sol-  
 dering or unsoldering.

## TABLE OF CONTENTS

<u>Section</u>	<u>Title</u>	<u>Page</u>	<u>Section</u>	<u>Title</u>	<u>Page</u>
	SERVICE NOTE .....	4	4.	PRINTED WIRING BOARDS AND SCHEMATIC DIAGRAMS	
1.	GENERAL		4-1.	Frame Schematic Diagram .....	4-5
	Getting Started .....	1-1	4-2.	Printed Wiring Boards and Schematic Diagrams .....	4-9
	Recording – Basics .....	1-5		VC-216 Printed Wiring Board .....	4-9
	Playback – Basics .....	1-7		VC-216 (LENS MOTOR DRIVE, CCD IMAGER) Schematic Diagram .....	4-13
	Advanced Recording Operations .....	1-8		VC-216 (CAMERA SIGNAL PROCESS) Schematic Diagram .....	4-17
	Advanced Playback Operations .....	1-11		MAIN Printed Wiring Board .....	4-21
	Editing .....	1-14		MAIN (AUDIO/VIDEO DATA CONTROL) Schematic Diagram .....	4-29
	Drawing/Effect .....	1-19		MAIN (MPEG ENCODER/DECODER) Schematic Diagram .....	4-33
	Customizing Your Camcorder .....	1-21		MAIN (RF AMP/DRIVE) Schematic Diagram .....	4-39
	Using with Other Equipment .....	1-23		MAIN (DIGITAL SIGNAL PROCESSOR) Schematic Diagram .....	4-43
	Additional Information .....	1-26		MAIN (SYSTEM CONTROL) Schematic Diagram .....	4-48
	Quick Reference .....	1-28		MAIN (VIDEO) Schematic Diagram .....	4-53
2.	DISASSEMBLY			MAIN (AUDIO) Schematic Diagram .....	4-56
2-1.	Main Control Switch Unit .....	2-3		MAIN (SWITCHING REGULATOR) Schematic Diagram .....	4-59
2-2.	Cabinet (R) Section .....	2-3		MAIN CONTROL SWITCH UNIT, ZOOM SWITCH UNIT Schematic Diagram .....	4-62
2-3.	Zoom Switch Unit .....	2-3		UPPER CONTROL SW SUB ASSY, REMOCON RAY-CATCHER BLOCK UNIT, LCD DETECTION SW FLEXIBLE Board Schematic Diagram .....	4-65
2-4.	Power Board .....	2-4		CLV Printed Wiring Board .....	4-68
2-5.	Ether Board .....	2-4		CLV Schematic Diagram .....	4-75
2-6.	Jack Board .....	2-4		REC Printed Wiring Board and Schematic Diagram .....	4-79
2-7.	Remote Terminal Unit .....	2-5		VF Printed Wiring Board .....	4-83
2-8.	Battery Case Assembly .....	2-5		VF Schematic Diagram .....	4-87
2-9.	Microphone Block .....	2-5		BL Printed Wiring Board .....	4-93
2-10.	Main Board .....	2-6		BL Schematic Diagram .....	4-97
2-11.	Lens Block (CT-DCMM1-164) .....	2-6		LCD Printed Wiring Board .....	4-101
2-12.	Hinge Cover .....	2-6		LCD Schematic Diagram .....	4-106
2-13.	LCD Block .....	2-7		ETHER Printed Wiring Board .....	4-109
2-14.	LCD Cabinet Assembly (U) .....	2-7		ETHER Schematic Diagram .....	4-116
2-15.	LCD Board .....	2-7		JACK Schematic Diagram .....	4-119
2-16.	Fluorescent Tube .....	2-8		JACK Printed Wiring Board .....	4-121
2-17.	Touch Panel, LCD Module (LCD4301) .....	2-8		POWER Printed Wiring Board .....	4-125
2-18.	EVF Block .....	2-8		POWER Schematic Diagram .....	4-130
2-19.	VF Board .....	2-9	4-3.	Waveforms .....	4-133
2-20.	VF Lens Assembly .....	2-9			
2-21.	BL Board .....	2-9			
2-22.	Upper Panel Assembly .....	2-9			
2-23.	Mechanism Deck (MT-DCMM1-163) .....	2-10			
2-24.	CLV Board .....	2-10			
2-25.	Stepper Block Assembly (M5811) .....	2-11			
2-26.	Holder Assembly .....	2-11			
2-27.	Service Position .....	2-12			
2-28.	Circuit Boards Location .....	2-14			
2-29.	Flexible Boards Location .....	2-16			
3.	BLOCK DIAGRAMS		5.	EXPLODED VIEWS	
3-1.	Overall Block Diagram .....	3-1	5-1.	Main Section .....	5-1
3-2.	Camera Signal Process Block Diagram .....	3-3	5-2.	Cabinet (R) Section .....	5-2
3-3.	Camera Control Block Diagram .....	3-5	5-3.	Microphone Block Section .....	5-3
3-4.	A/V Data Control, Video Out Block Diagram .....	3-7	5-4.	Cabinet (L) Section .....	5-4
3-5.	MPEG Encode Block Diagram .....	3-9	5-5.	LCD Block Section .....	5-5
3-6.	MD Signal Process Block Diagram .....	3-11	5-6.	EVF Block Section .....	5-6
3-7.	MD Servo Block Diagram .....	3-13	5-7.	Lens Block Section (CT-DCMM1-164) .....	5-7
3-8.	System Control Block Diagram .....	3-15	5-8.	Mechanism Deck Section-1 (MT-DCMM1-163) .....	5-8
3-9.	Audio Block Diagram .....	3-17	5-9.	Mechanism Deck Section-2 (MT-DCMM1-163) .....	5-9
3-10.	LCD Block Diagram .....	3-19			
3-11.	EVF Block Diagram .....	3-21			
3-12.	Mode Control Block Diagram .....	3-23	6.	ELECTRICAL PARTS LIST .....	6-1
3-13.	Ether Interface Block Diagram .....	3-25			
3-14.	Power 1 Block Diagram .....	3-27			
3-15.	Power 2 Block Diagram .....	3-29			
3-16.	Power 3 Block Diagram .....	3-31			

\* The color reproduction frame is shown after the page of ELECTRICAL PARTS LIST.

## SERVICE NOTE

### • NOTE FOR REPAIR

Make sure that the flat cable and flexible board are not cracked or bent at the terminal.

Do not insert the cable insufficiently nor crookedly.

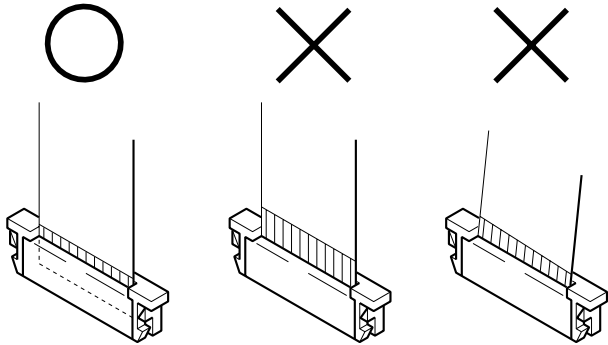

Cut and remove the part of gilt which comes off at the point.  
(Take care that there are some pieces of gilt left inside)

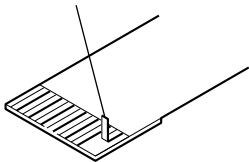

When remove a connector, don't pull at wire of connector.  
Be in danger of the snapping of a wire.

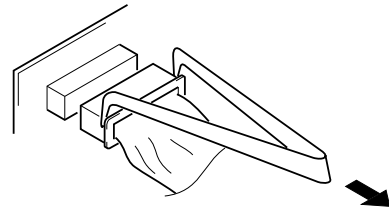

When installing a connector, don't press down at wire of connector.  
Be in danger of the snapping of a wire.

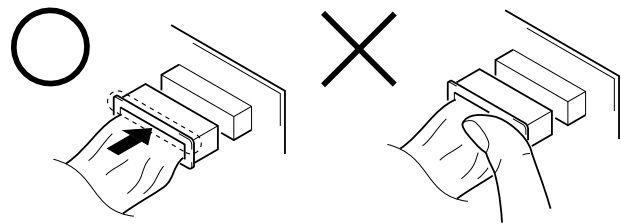

- When repairing this device with the power on, if you remove the MAIN board or open the upper panel assy, this device stops working.

In this case, you can work without the device stopping by fastening the hook of the open/close detect switch (S8003) on the MAIN Board with tape.

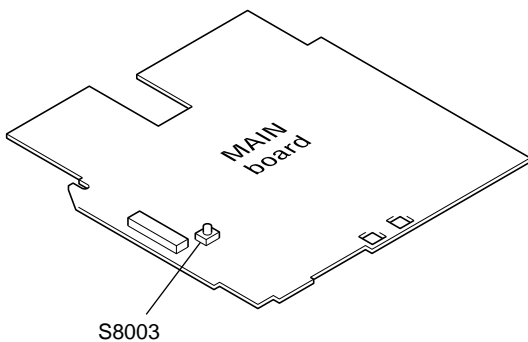

# SECTION 1 GENERAL

This section is extracted from instruction manual. (3-866-152-11)

## What you can do with your camcorder

Your camcorder can record in the MD DATA2 disc:  
 • Moving pictures (movies) as long as 10 minutes in SP mode or 20 minutes in LP mode  
 • Still pictures (photos) of up to 4,500 shots  
 • Audio of up to 260 minutes.

You can select the picture to play back directly by touching the LCD screen.  
 Play or edit the picture by touching the menu displayed on the LCD screen.

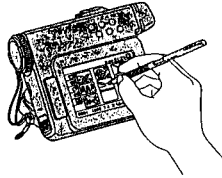

Hold the camcorder with both hands when recording.



Insert the disc from the bottom of the camcorder.

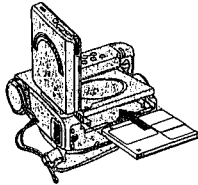

Getting started

## What you can do with your camcorder

### Various functions available with MiniDisc

Digital video edit functions (p. 58)

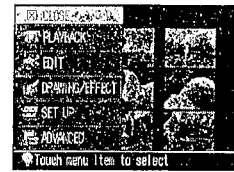

Check the picture just after recording (p. 47)

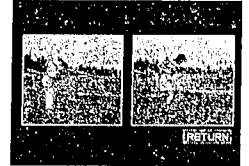

Draw on the picture (p. 78).

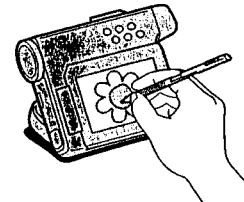

Easy to move or erase the picture (p. 64, 65)

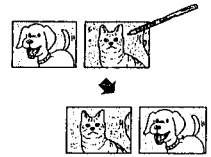

Long audio recording including three photos - Interview recording (p. 36)

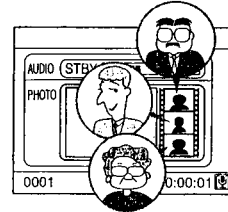

Listen to audio MD (p. 98).

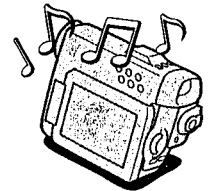

5 6

## Checking supplied accessories

Make sure that the following accessories are supplied with your camcorder.

1	2	3
4	5	6
7	8	9
10	11	12

- 1 AC-VQ800 AC adaptor/charger (1) (p. 10, 15)
- 2 AC power cord (1) (p. 10, 15)
- 3 MMD-650A MD DATA2 disc (1) (p. 16)
- 4 ZK-ET1 connecting cord (1) (p. 15)
- 5 NP-F550 battery pack (1) (p. 10, 14)
- 6 RMT-DCM1 Wireless Remote Commander (1) (p. 32)
- 7 Size AA (R6) battery for Remote Commander (2) (p. 125)
- 8 Input pen (1) (p. 18)
- 9 Tripod attachment (1) (p. 122)
- 10 A/V connecting cable (1) (p. 35)
- 11 Lens cap (1) (p. 22)
- 12 Ferrite cores (large x 1, small x 2) (p. 124)
- 13 Shoulder belt (p. 121)

Getting started

## Getting Started — Using this manual

As you read through this manual, the buttons and settings on your camcorder are shown in capital letters.

For example, "set the POWER switch to CAMERA."

When you carry out an operation, you will hear a beep to indicate that the operation is being carried out.

### What is a "track"?

A picture or audio recorded in the MiniDisc is called "track." A track can be of any length and varies depending on how long you recorded the picture or audio.

- **Movie track**  
The track starts when you press START/STOP to begin recording and ends when you press START/STOP again to stop recording. (If you have selected the "ANTI GROUND" recording mode in the menu (p. 93), a track is made while you are pressing START/STOP.)
- **Photo track**  
A photo makes one track.
- **Interview recording (Audio track)**  
The track starts when you press AUDIO REC to begin audio recording and ends when you press ■ to stop recording. If you record photos during audio recording, the track includes those photos.
- **Title track and Drawing track**  
The title track or drawing track makes an individual track, except when you draw on a picture.

Each track is automatically assigned a track number. You can label the track yourself.

The tracks are produced on a disc as shown below. On the index display, each track is indicated by one image regardless of the length or type of the track.

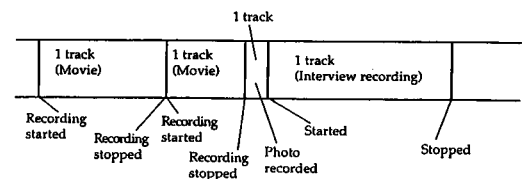

### When you edit the picture or audio

Editing the picture and audio is done by tracks. When you move, erase or copy the picture or audio, the track of the selected picture or audio is moved, erased or copied.

7 8

## Using this manual

### Note on TV color systems

TV color systems differ from country to country. To view your recordings on a TV, you need an NTSC system-based TV.

### Copyright precautions

Television programs, films, video tapes, and other materials may be copyrighted. Unauthorized recording of such materials may be contrary to the provision of the copyright laws.

### Precautions on camcorder care

- The LCD screen and/or the color viewfinder are manufactured using high-precision technology. However, there may be some tiny black spots and/or bright spots (red, blue or green in color) that constantly appear on the LCD screen and/or in the color viewfinder. These spots occur normally in the manufacturing process and do not affect the recorded picture in any way. Effective number of pixels is 99.99% or more.
- Do not let your camcorder get wet. Keep your camcorder away from rain and sea water. Letting your camcorder get wet may cause your camcorder to malfunction. Sometimes this malfunction cannot be repaired [a].
- Never leave your camcorder exposed to temperatures above 140°F (60°C), such as in a car parked in the sun or under direct sunlight [b].
- Do not place your camcorder so as to point the viewfinder or the LCD screen toward the sun. The inside of the viewfinder or LCD screen may be damaged [c].

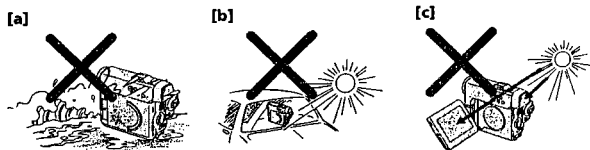

### Note on heating

- Your camcorder may heat up during operation due to the internal circuit operation. This is not a malfunction. The temperature differs depending on the operating mode.
- If your camcorder and AC adaptor/charger heat up more than usual, turn off your camcorder and remove the battery pack. When using on the AC adaptor/charger, disconnect the AC adaptor/charger from a wall outlet. Then contact your nearest Sony dealer.

Contents of the recording cannot be compensated if recording or playback is not made due to a malfunction of the camcorder, MiniDisc, etc.

Getting started

## Step 1 Preparing the power supply

### Charging the battery pack

Use the battery pack after charging it for your camcorder.

Your camcorder operates only with the "InfoLITHIUM" battery pack (L series). If you want to use the camcorder right away indoors, use on the AC adaptor/charger (p. 15).

(1) Set the mode change switch to "CHARGE."

(2) Connect the power cord to the AC adaptor/charger.

(3) Connect the power cord to a wall outlet.

A beep sounds and the display window lights up.

(4) Place the battery pack on the AC adaptor/charger with the ◀ mark facing the terminal shutter.

(5) Slide the battery pack in the direction of the arrow.

Press the battery pack until the terminal shutter enters completely into the AC adaptor/charger.

Charging begins. When the remaining battery indicator becomes  and the CHARGE lamp lights up, normal charge is completed. For full charge, which allows you to use the battery slightly longer than "normal charge," leave the battery pack attached until the CHARGE lamp goes out.

Remove the battery pack when required. It can be used even if the charging is not completed.

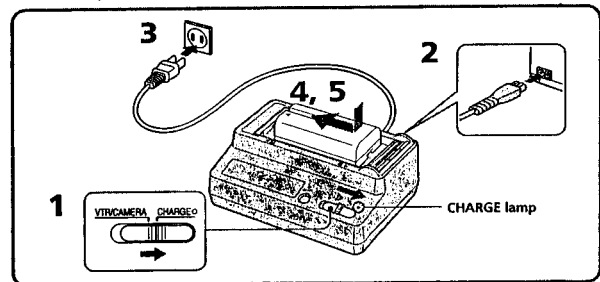

### To remove the battery pack

Slide the battery pack in the opposite direction of installing, then lift it straight out.

9

10

## Step 1 Preparing the power supply

### Notes

- When the mode change switch is set to VTR/CAMERA during charging, charging stops.
- If the CHARGE lamp does not light or flash, check that the battery pack is correctly attached to the AC adaptor/charger. If it is not attached it will not be charged.
- When you install the battery pack, be sure to not hit it to the terminal of the AC adaptor/charger.
- Be sure that nothing metallic comes into contact with the metal parts of the unit or connecting plate. If it does, a short may occur and the unit may be damaged.



### Charging time

The following table shows the charging time for the battery pack which is discharged completely.

Battery pack	Full charge (Normal charge)
NP-F550 (supplied)	115 (55)

- Approximate minute to charge an empty battery pack fully (Full charge).
- Approximate minutes in parentheses indicates the time when you charge normally (Normal charge).
- The charging time may differ depending on the condition of the battery pack or the temperature of the environment.

### Remaining battery indicator

Normal charge	Full charge
	

### Recording time

Battery pack	Recording with the viewfinder		Recording with the LCD screen	
	Continuous*	Typical**	Continuous*	Typical**
NP-F550 (supplied)	75 (70)	37 (35)	65 (60)	32 (30)

- Approximate minutes when you use a fully charged battery
- Numbers in parentheses indicate the time using a normally charged battery.
- If you use both of the LCD screen and the viewfinder, the recording time will be slightly shorter than recording with the LCD screen only.
- Approximate continuous recording time at 77°F (25°C). The battery life will be shorter if you use your camcorder in a cold environment.
- Approximate minutes when recording while you repeat recording start/stop, zooming and turning the power on/off. The actual battery life may be shorter.

Getting started

## Step 1 Preparing the power supply

### Playing time

#### MD DATA2 disc

Battery pack	Playing time on LCD screen	Playing time with LCD closed
NP-F550 (supplied)	80 (75)	100 (95)

#### Audio MD

Battery pack	Playing time on LCD screen	Playing time with LCD closed
NP-F550 (supplied)	100 (95)	135 (130)

- Approximate minutes when you use a fully charged battery
- Numbers in parentheses indicate the time using a normally charged battery.
- The battery life will be shorter if you use your camcorder in a cold environment.

### To check charging

During charging, you can check the charging time on the display. BATTERY LIFE lights up on the display shortly after charging has started.

Press DISPLAY CHANGE during charging.

Each time you press DISPLAY CHANGE, the display changes as follows.

The remaining battery time when the battery pack being charged is attached to an "InfoLITHIUM" equipment.

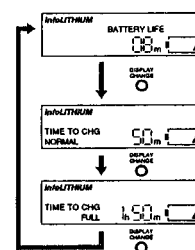

The time is not displayed when the remaining battery time is less than 5 minutes.

The remaining time until normal charge is completed.

The remaining time until full charge is completed.

11

12

## Step 1 Preparing the power supply

### What is "InfoLITHIUM?"

The "InfoLITHIUM" is a lithium ion battery pack which can exchange data with compatible electronic equipment about its battery consumption. Sony recommends that you use the "InfoLITHIUM" battery pack with electronic equipment having the  mark.

### Notes

- The time display shows the approximate time when charging at 50°F to 86°F (10°C to 30°C). The time display may differ from the actual charging time depending on using conditions and circumstances.
- The time display may show "----" in the following cases. However, the AC adaptor/charger is not malfunctioning.
  - The remaining battery time is less than 5 minutes.
  - There is a difference between the displayed time and actual charging time. Even if this happens, continue charging.
- Full charge requires about 1 hour after normal charge is completed. If you remove the battery pack between normal charge and full charge, the charging time may not be displayed properly in the next charging.
- If the charging time is not displayed properly, fully charge the battery pack. The charging time will be displayed properly.
- When you attach a fully charged battery pack to this AC adaptor/charger, "TIME TO CHG FULL 1h" may appear on the display. However, this is not a malfunction.
- You may wait for a while after pressing DISPLAY CHANGE until the display shows the time indication.
- To display the remaining battery time of a new battery, attach it to your camcorder and use it for about 30 seconds. Then, charge the battery with the AC adaptor/charger.

Getting started

## Step 1 Preparing the power supply

### Installing the battery pack

Install the battery pack to use your camcorder outdoors.

- Slide OPEN (BATT) down to open the battery compartment lid.
- With the  mark pointing down, insert the battery pack until it clicks.
- Shut the lid.

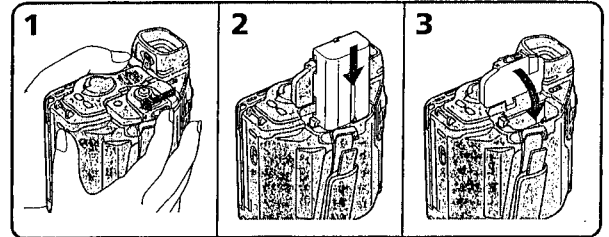

### To remove the battery pack

Open the lid and push the catch.

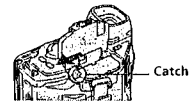

### Note

Put your hand by the battery compartment lid to prevent the battery pack from dropping.

### Remaining battery time indicator of the camcorder

- Approximate time remaining for continuous recording will be displayed on the LCD screen or in the viewfinder. The time may not be correct depending on the condition or environment the camcorder is used.
- It will take about 1 minute for the camcorder to display a correct remaining time when you open or close the LCD screen.
- The remaining time displayed on the camcorder may differ from that on the AC adaptor/charger.

13

14

## Step 1 Preparing the power supply

### Connecting to a wall outlet

When you use your camcorder for a long time, we recommend that you power it from a wall outlet using the AC adaptor/charger.

- Set the mode change switch to VTR/CAMERA.
- Connect the power cord to a wall outlet.
- Connect the power cord to the AC adaptor/charger.
- Connect the connecting cord to the DC OUT connector of the AC adaptor/charger.
- Install the connecting cord to the camcorder.  
Insert the connecting adaptor until it clicks. Pass the cord through the cord shutter so that the cord is not caught by the battery lid.

Getting started

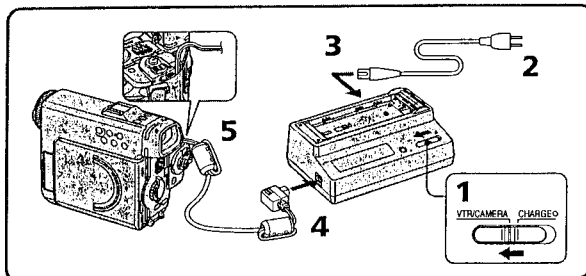

### To disconnect the connecting cord

Open the lid and push the catch.

### Notes

- If you set the mode change switch to CHARGE while operating the camcorder, the power supply to the camcorder stops.
- Be sure that nothing metallic comes into contact with the metal parts of the AC adaptor/charger. If it does, a short may occur and the AC adaptor/charger may be damaged.
- You cannot charge the battery pack attached to the AC adaptor/charger while supplying the power to the camcorder.
- Keep the AC adaptor/charger away from the camcorder if the picture is disturbed.
- The power cord must only be changed at an authorized service shop.
- The AC adaptor/charger is not disconnected from the AC power source (house current) as long as it is connected to the wall outlet, even if the AC adaptor/charger itself has been turned off.

### Using a car battery

Use Sony DC adaptor/charger DC-VQ800 (not supplied) or car battery adaptor DCC-L50 (not supplied).

15

16

## Step 2 Inserting an MD DATA2 disc

Use an MD DATA2 disc. You cannot record on other types of MDs.

- Lift the  and open the LCD panel until it stops.
- Slide DISC EJECT on the bottom in the direction of the arrow and open the lid manually.
- Insert the disc.  
Push the disc in the direction of the arrow deeply into the disc compartment with the label facing up.
- Close the disc lid.

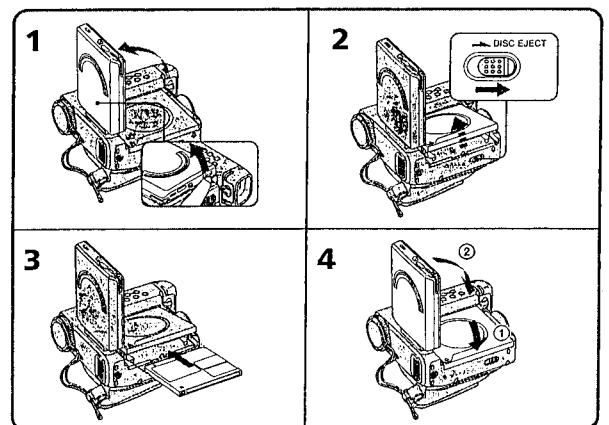

### To eject the disc

Follow the procedure above, and take out the disc in step 3.

### Notes

- If the POWER switch is set to "CAMERA" or "INTERVIEW," you may not be able to eject the disc. If this happens, turn off the power first and then reconnect the power sources. Then try again.
- Do not face the disc opening down when you insert or eject a disc to avoid dropping the disc.

### To prevent misoperation

Turn the POWER switch to "OFF" when you insert or eject a disc.

## Step 2 Inserting an MD DATA2 disc

To prevent accidental erasure  
Slide open the tab at the side of the disc (so the tab is concealed).

Rear of the disc

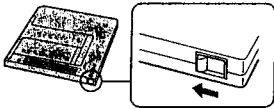

Getting started

## Step 3 Using the touch panel

You operate your camcorder by selecting the items on the index display or menu on the LCD screen.  
Select the tracks or menu items by touching with the input pen or a finger, or using the control dial.  
The operation will be described mainly by touching the LCD screen with the input pen in this manual.  
How to operate the menu is described here as an example.

### Using the input pen

Example: turning off the beep

(1) Pull out the input pen.

Adjust the length of the input pen. The length of the input pen can be extended by about 12/32 inch (about 1 cm).

(2) Lift the OPEN protrusion and open the LCD panel. Turn the LCD panel over and move it back into the camcorder body with the LCD screen facing out.  
You will get more accurate results by touching the LCD screen in this position.

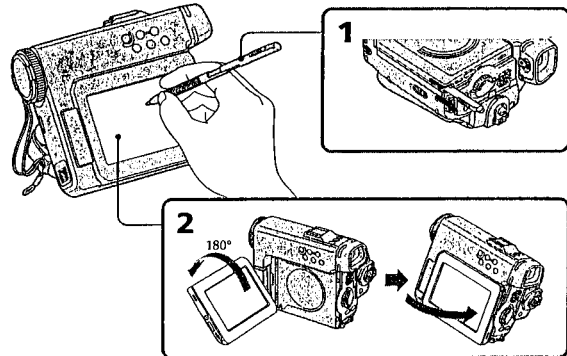

17

18

## Step 3 Using the touch panel

- (3) Set the POWER switch to PLAY/EDIT while pressing the small green button. The index display appears. If nothing is recorded in the disc, no index image will be displayed.
- (4) Touch SET UP on the left of the screen.
- (5) Touch BEEP.
- (6) Touch OFF.
- (7) Touch to close the menu. The index display appears.

Getting started

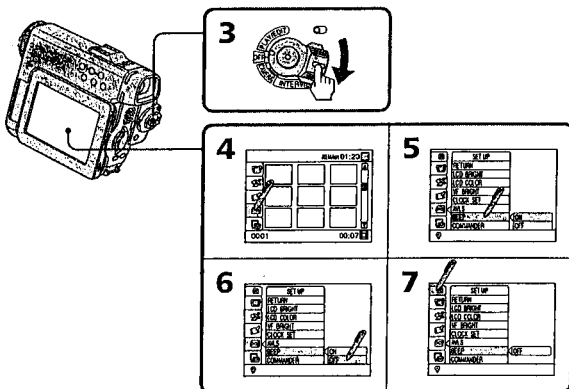

### Notes on the LCD screen

- Operative pressure may be influenced by the atmospheric temperature or pressure.
- You can touch the LCD panel directly with a finger. Do not touch the LCD panel with a wet hand.
- Do not push on the LCD screen with a pointed object such as a pen.

### Notes on the input pen

- Use only the supplied input pen. You may not be able to operate your camcorder with other commercially available input pens.
- Do not push on or hit the LCD panel hard with the input pen. Doing so may cause your camcorder to malfunction.
- Take care not to damage or dirty the tip of the input pen.
- If you made the input pen longer, shorten it to the original length before you put it back into your camcorder.

19

20

## Step 3 Using the touch panel

If the LCD screen is dirty

- Do not use the input pen when the LCD screen is dirty or dusty. Doing so may damage the LCD screen.
- If the LCD screen is dirty, turn the POWER switch to "OFF" first and then wipe the LCD screen lightly with a soft dry cloth.

If the LCD screen does not react correctly to touching

Calibrate it (p. 108).

When PLEASE WAIT is displayed on the LCD screen

Do not apply a mechanical shock to the camcorder, or disconnect the power source.

### Using the shortcut menu

You can display some of the menu items quickly.

(1) Press MENU during playback or pause.

The shortcut menu appears.



(2) Touch the desired item. The setting or adjusting display of the item appears.

To turn off the shortcut menu

Press MENU again.



### Step 3 Using the touch panel

#### Using the control dial

- Turn the control dial up or down to select an item, and press it to confirm. The control dial rotates up or down endlessly.
- Example: turning on the digital zoom function
- (1) Set the POWER switch to CAMERA while pressing the small green button.
  - (2) Press MENU.
  - (3) Turn the control dial to select CAMERA and press the dial.
  - (4) Turn the control dial to select D ZOOM and press the dial.
  - (5) Turn the control dial to select ON and press the dial.
  - (6) Press MENU to close the menu.

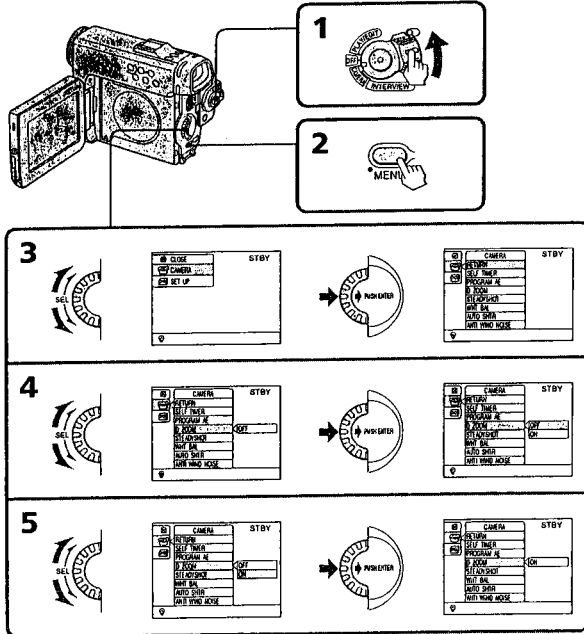

Getting started

### — Recording - Basics —

## Recording a picture

Your camcorder automatically focuses for you.

- (1) Install the power source and insert a disc. See "Step 1" and "Step 2" for more information (p. 10 to p. 17).
- (2) Fasten the grip strap firmly.
- (3) Remove the lens cap and pull the lens cap string to fix it.
- (4) Set the POWER switch to CAMERA while pressing the small green button. Your camcorder is set to the standby mode after a few seconds.
- (5) To record a movie:  
Press START/STOP. Your camcorder starts recording. The "REC" indicator appears. The camera recording lamp located on the front of your camcorder lights up. To stop recording, press START/STOP again.  
To record a photo:  
Press PHOTO once. The scene when you press the button is recorded.

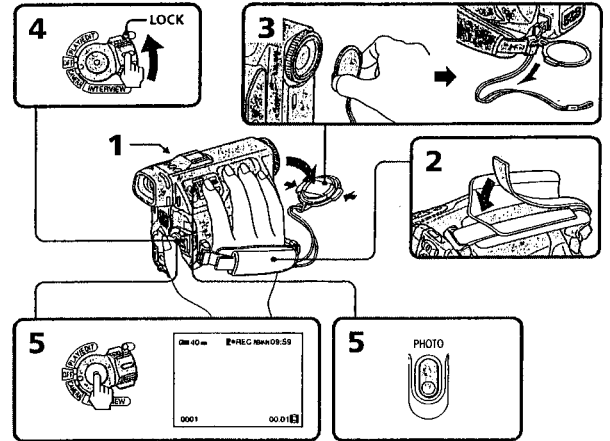

21 22

### Recording a picture

If you want to record longer  
Select the LP (long play) recording mode in the menu (p. 26). The available recording time becomes twice the SP (standard play) mode; however, the picture quality will not be as good as the SP mode.

If you leave your camcorder in the standby mode for five minutes  
Your camcorder automatically turns off. This is to save battery power. To resume the standby mode, set the POWER switch to OFF and to CAMERA again.

#### While writing in the MD

The "STBY" indicator on the LCD screen flashes.

- While the "STBY" indicator is flashing, make sure that you do not:
  - shake or hit the camcorder.
  - turn off the camcorder.
  - eject the disc and the battery.

The above may damage the picture data and disc.

- While the "STBY" indicator is flashing, you cannot start the next recording.

#### One recording makes one track

- From when you press START/STOP to begin recording until you press START/STOP to stop recording makes one track and is written in the disc as the last recorded track.
- In the ANTI GROUND recording mode, recording while you are pressing START/STOP makes one track (p. 93).
- You can renew tracks every 10 seconds (p. 93).
- One photo makes one track.

#### Note on recording a photo

If you record a fast moving object, the playback picture may look blurred. This is not a malfunction of your camcorder.

#### To record in the dark

Use a video light (not supplied). You can use a video light when  $\frac{1}{2}$  is displayed on the LCD screen. If you are adjusting the exposure manually, the video light does not flash ( $\frac{1}{2}$  is not displayed).

#### Note on the LOCK switch

When you slide the LOCK switch to the left, the POWER switch cannot be set to INTERVIEW accidentally. The LOCK switch is set to the right as the default setting.

#### Note on the microphone

Do not touch the built-in microphone during recording.

#### If you are recording in strong wind

Set ANTI WIND NOISE to ON in the menu to reduce the wind noise (p. 92).

If you input audio from the LINE IN jack of the connecting cord during recording

The audio from the LINE IN jack is recorded.

#### If you are using headphones

The sound from headphones will be muted for a moment when you start and stop recording. The sound recorded in the disc is not affected. (The situation is same for the speaker output when audio equipment is connected to LINE IN.)

Recording - Basics

### Recording a picture

#### After recording

- (1) Set the POWER switch to OFF.
- (2) Eject the disc.
- (3) Remove the battery pack.

If you remove the battery before ejecting the disc  
Since the disc lid is locked in the CAMERA and INTERVIEW mode, you cannot open the disc lid without the battery.

#### Indicators displayed in the recording mode

The indicators are not recorded in the disc.

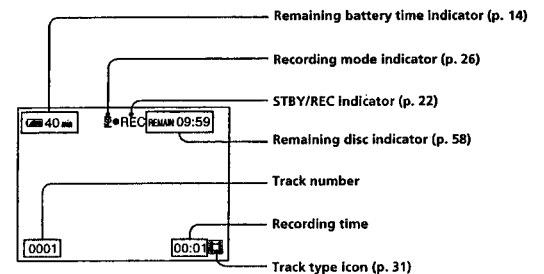

23 24

## Recording a picture

### Adjusting the LCD screen

- (1) Pull the ◀OPEN protrusion and open the LCD panel.
- (2) Adjust the angle.

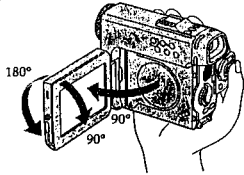

To close the LCD panel, set it vertically and swing it into the camcorder body.

#### Note

When using the LCD screen except in the mirror mode, the viewfinder automatically turns off.

#### When you use the LCD screen outdoors in direct sunlight

The LCD screen may be difficult to see. If this happens, we recommend that you use the viewfinder.

#### When you adjust angles of the LCD panel

Make sure that the LCD panel is opened up to 90 degrees. Do not open or turn the LCD screen forcibly.

#### When you adjust the brightness of the LCD panel

Select LCD BRIGHT in the menu and adjust (p. 87). This adjustment does not change the picture brightness recorded in the disc.

Recording - Basics

25

26

## Recording a picture

### Using the zoom feature

- (1) Move the power zoom lever a little for a slower zoom. Move it further for a faster zoom.

Using the zoom function sparingly results in better-looking recordings.

"T" side: for telephoto (subject appears closer)

"W" side: for wide-angle (subject appears farther away)

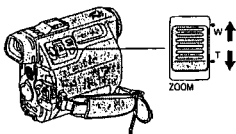

Zoom greater than 10x is performed digitally, if you set D ZOOM to ON in the menu settings. The digital zoom function is set to OFF as a default setting (p. 92).

The right-ended portion of the bar shows the digital zooming zone. The digital zooming zone appears when you set D ZOOM to ON.

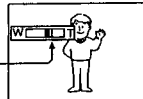

#### When you shoot close to a subject

If you cannot get a sharp focus, move the power zoom lever to the "W" side until the focus is sharp. You can shoot a subject that is at least about 2 feet 5/8 inch (about 80 cm) away from the lens surface in the telephoto position, or about half an inch (about 1 cm) away in the wide-angle position.

#### Notes on digital zoom

- Digital zoom starts to function when zoom exceeds 10x.
- The picture quality deteriorates as you go toward the "T" side. Set D ZOOM to OFF in the menu settings. Otherwise the digital zoom activates without notice (p. 92).

Recording - Basics

27

28

## Recording a picture

### Adjusting the viewfinder

When you record pictures with the LCD panel closed, check the picture with the viewfinder. Adjust the viewfinder lens to your eyesight so that the indicators in the viewfinder come into sharp focus.

- (1) Move the viewfinder lens adjustment lever.

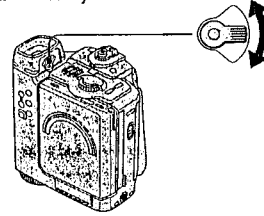

### Recording time

One MD DATA2 disc can record:

Track type	Record mode	Recording time
Movie	SP mode	Max. 10 min.
	VP mode	13 min. to 20 min.
	LP mode	Max. 20 min.
Photo		Max. 4500 shots
Audio		Max. 260 min.

#### Recording mode of movie

SP (standard play):

High picture quality (the default setting).

VP (variable picture quality):

The data consumption is automatically adjusted according to the object being recorded. The deterioration of picture quality is kept to a minimum and the recording time is longer than the SP mode.

LP (long play):

The recording time is double the SP mode. The picture quality is lower than the SP mode.

To select the recording mode

- (1) Press MENU.
- (2) Select REC MODE in SET UP.
- (3) Select the desired recording mode.

#### Note on deterioration of picture quality

The playback picture of a subject which moves fast or changes brightness may have block-shaped noise or rough outlines.

## Recording a picture

### Recording while showing the picture on the LCD screen

You can record a person while showing himself/herself on the LCD screen. You can also record yourself if you place your camcorder in a stable position. The supplied Remote Commander will make it easy to record yourself.



- (1) Pull the ◀OPEN protrusion and open the LCD panel.
- (2) Turn the LCD panel over so that it faces the other way.

The indicator appears on the LCD screen and in the viewfinder (Mirror mode).

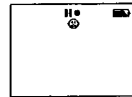

- (3) Start recording.

#### Picture in the mirror mode

The picture on the LCD screen is a mirror-image. However, the picture will be normal when recorded.

#### Indicators in the mirror mode

The STBY indicator appears as and REC as . Some of the other indicators appear mirror-reversed and others are not displayed.

#### Recording time using the battery pack in the mirror mode

Recording time is slightly shorter than the recording time using the LCD screen only (p. 11).

## Checking the recorded picture

You can view the picture just after you have recorded with the POWER switch kept to CAMERA.  
You can erase the track or unnecessary portion of the track.

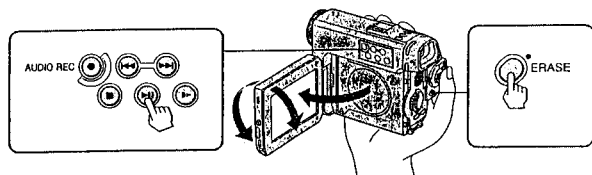

Recording - Basics

### Viewing the last recorded track

- (1) During recording standby, press ►II.  
The last picture you recorded will be played repeatedly.  
Press ■ to stop playing.

### Erasing the last recorded track

- (1) During recording standby or playing, press ERASE.  
The last recorded track is played and the confirmation message appears.

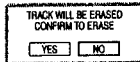

- (2) Turn the control dial to select YES, and press the dial to confirm.  
After the PLEASE WAIT message which appears while the change is written in the disc, the camcorder returns to the recording standby mode. The track is erased.

**Note**  
You cannot restore the track once it has been erased.

**To erase all tracks**  
While pressing ERASE, press START/STOP.

### Erasing the last portion of the last recorded track

- (1) During recording standby, press ►II.  
The last picture you recorded will be played repeatedly.
- (2) At the scene from where you want to erase, press ►II to pause.
- (3) Press ERASE.  
The portion to be erased is played and the confirmation message appears.
- (4) Turn the control dial to select YES, and press the dial to confirm.  
That portion of the track is erased.

29 30

## Playing a disc

**When you open/close the LCD panel**  
Make sure that the LCD panel is set vertically.

**Note on playback**  
It may take a few seconds to start playback depending on the track.

**To change the playing time of a photo**  
Set STILL PLAYBACK TIME in the menu (p. 57).

**If you leave the power on for a long time**  
Your camcorder gets warm. This is not a malfunction.

### Index display

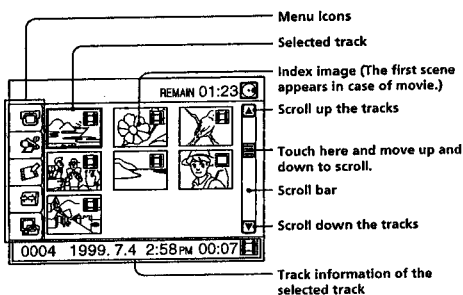

**Track icons**  
Type of track is indicated by the icons.

- Movie track
- Photo track
- Audio track
- Title track
- Memo track
- Group track

**To change the index image of a movie**  
You can use the scene you want (p. 62).

**If date and time are not set in your camcorder**  
"----" appears.

Playback - Basics

31 32

## Playing the disc

You can monitor the playback picture on the LCD screen. If you close the LCD panel, you can monitor the playback picture in the viewfinder.  
When you monitor the picture on the LCD screen, tilt your camcorder to its stable position.

- (1) Install the power source and insert the recorded disc.
- (2) Pull out the input pen.  
Adjust the length of the input pen. The length of the input pen can be extended by 12/32 inch (about 1 cm).
- (3) Lift the ◀OPEN protrusion and open the LCD panel. Turn the LCD panel over and move it back into the camcorder body with the LCD screen facing out.
- (4) Set the POWER switch to PLAY/EDIT while pressing the small green button.  
The tracks of recorded pictures appear on the index display.
- (5) Touch the track you want to play with the input pen.  
The selected track is framed in orange.
- (6) Touch the track again to start playing.  
The frame turns red.  
The photo tracks are played for three seconds each.

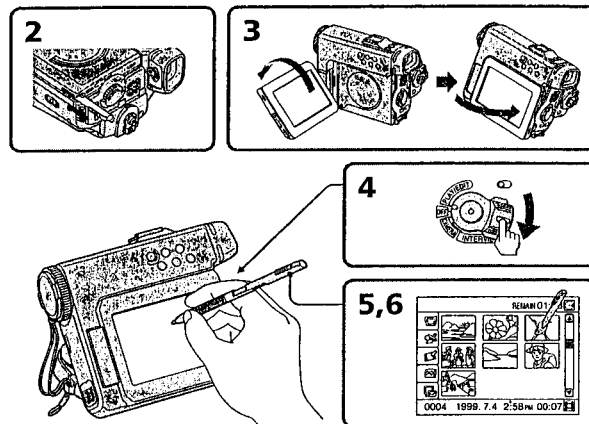

**To stop playing**  
Press ■.

## Playing a disc

### To control using the buttons on the camcorder or Remote Commander

When the name of the buttons of the camcorder differs from the buttons of the Remote Commander, those of the Remote Commander are shown in parenthesis.

- To play**
- Select the desired track, then press ►II (►).
  - Turn the control dial (press cursor ◀/▶/▲/▼) to select the desired track, then press the dial (ENTER).

**To stop**  
Press ■ during playback.

**To pause**  
Press ►II (II) during playback.  
To return to normal play, press ►II (II) again.

**To go to the next track**  
Press ►I briefly during playback. Each time you press ►I, it goes to the top of the next tracks.

**To go to the previous track**  
Press ◀I briefly during playback. First press of ◀I goes to the top of the current track. If you repeat pressing ◀I in sequence, it goes to the top of the previous track.

**To locate a scene monitoring the picture**  
Keep pressing ◀I or ►I during playback. To resume normal playback, release the button.

**To view the picture frame-by-frame**

- (1) Press ►II (II) during playback.
- (2) Turn the control dial (press cursor ◀/▶/▲/▼).

To resume normal playback, press ►II (►).

**To view the picture at slow speed (movie only)**  
You can play at the desired speed.

- (1) Press ► during playback.  
The picture is played at 1/3 speed. The speed adjusting bar appears.
- (2) Turn the control dial (press cursor ◀/▶/▲/▼) to adjust the speed.  
To resume normal playback, press ►II twice.  
(On the Remote Commander, press ►).

**In the playback modes other than normal**  
Sound is muted.

**While playing still pictures**  
If you try frame-by-frame playback, it goes to the first frame of the next track.

**During slow playback**

- If you turn the control dial, the playing speed changes.
- If you press ◀I and ►I, slow playback is canceled.
- The speed adjusting bar appears at the beginning of slow play and while adjusting the speed.

## Playing a disc

### Adjusting the volume

- (1) Press either of the two buttons on VOL.

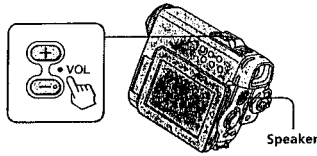

Playback - Basics

**To set AVLS**  
Set AVLS to ON in the menu (p. 93).

**To listen using headphones**  
Connect the headphones (not supplied) to the  $\phi$  jack on the front. Adjust the volume using the VOL buttons. The speaker is muted.

## Playing a disc

### Turning on or off the information display

- (1) Press DSPL when the index display is on.  
The track type icons disappear from the LCD screen.

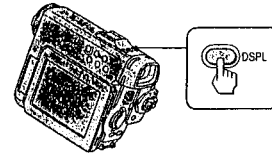

To make the track data appear, press DSPL again.

**If you press DSPL during playback**  
The track data appears.

### Erasing a track

- (1) Touch the track you want to erase on the index display.  
(2) Press ERASE.  
The confirmation message appears.  
(3) Touch YES.  
After the PLEASE WAIT message, which appears while the change is written in the disc, the index display appears. The track is erased.

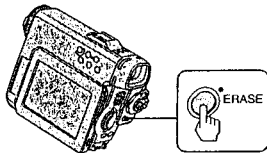

**Note**  
You cannot restore the track once erased.

**While playing**  
You can also erase the track by pressing ERASE while the track is being played.

33

34

## Viewing the recording on TV

Connect your camcorder to your TV or VCR with the A/V connecting cable supplied with your camcorder to watch the playback picture on the TV screen. You can operate the video control buttons in the same way as when you monitor playback pictures on the LCD screen. When monitoring the playback picture on the TV screen, we recommend that you power your camcorder from a wall outlet using the AC adaptor/charger (p. 15). Refer to the operating instructions of your TV or VCR.

Open the jack cover. Connect your camcorder to the TV using the A/V connecting cable supplied with your camcorder. Then, set the TV/VCR selector on the TV to VCR.

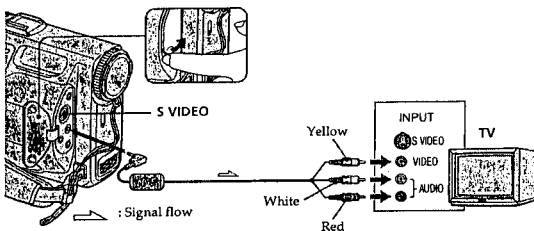

Playback - Basics

### If your TV is already connected to a VCR

Connect your camcorder to the LINE IN input on the VCR by using the A/V connecting cable supplied with your camcorder. Set the input selector on the VCR to LINE.

### If your TV or VCR is a monaural type

Connect the yellow plug of the A/V connecting cable to the video input jack and the white or the red plug to the audio input jack on the VCR or the TV. If you connect the white plug, the sound is L (left) signal. If you connect the red plug, the sound is R (right) signal.  
If you want to hear in monaural, use a monaural audio cable (not supplied).

**If your TV or VCR has an S video jack**  
Connect using an S video cable (not supplied) to obtain high-quality pictures. With this connection, you do not need to connect the yellow (video) plug of the A/V connecting cable.  
Connect the S video cable (not supplied) to the S video jacks on both your camcorder and the TV or the VCR.

35

36

## — Advanced Recording Operations —

### Recording audio including photo - Interview recording

While you are recording mainly audio in an MD DATA2 disc, you can record up to three photos. Those photos make one track together with the audio.  
Interview recording is possible only with the MD DATA2 discs. You can record up to 4 hours and 20 minutes in a disc.

The index image of the interview recording has the icon.

- (1) Unlock the mode lock and set the POWER switch to INTERVIEW while pressing the small green button.

- (2) Press AUDIO REC.

The AUDIO REC button lights up in red and recording starts. The recording time passed is indicated by which increases every 10 seconds. When reaches the right end, it starts over.

- (3) Press PHOTO when you want to insert photos.

If you have not started audio recording, you cannot record photos. The recorded photos appear to the right of the screen.

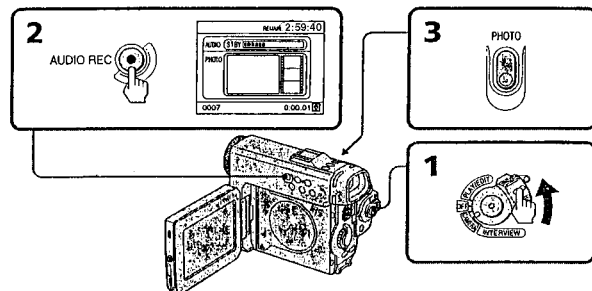

**To stop recording**  
Press .

**When you have finished interview recording**  
Slide the mode lock to the left to prevent the POWER switch from being set to INTERVIEW by accident.

**To use a microphone**  
Connect a microphone (not supplied) to the MIC jack on the front.

**To record for long time**  
We recommend that you power your camcorder from a wall outlet using the AC adaptor/charger (p. 15).

**If you record in mirror mode**  
The picture on the LCD screen does not become a mirror-image.

## Recording audio including photo - Interview recording

If you record from audio equipment such as a CD player  
Connect the audio equipment to the LINE IN jack of the connecting cord installed in your camcorder using an audio connecting cable (not supplied).

**Playback and erasing**  
You cannot play back or erase in the INTERVIEW mode.

**If you are using headphones**  
The sound from headphones will be muted for a moment when you start and stop recording. The sound recorded in the disc is not affected. (The situation is same for the speaker output when audio equipment is connected to LINE IN.)

### Playing the track recorded in the INTERVIEW mode

The audio track recorded in the INTERVIEW mode is displayed by the first photo with the  icon on the index display.  
Touch the track to start recording.

**Playback screen of the track recorded in the INTERVIEW MODE**  
You will hear the audio. On the LCD screen are a large blank screen and small photos to the right of the screen. When the recorded photo is reached during playback, the large screen will be replaced by the photo.

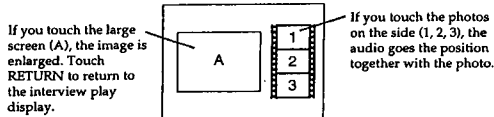

When the interview recording was done like this,

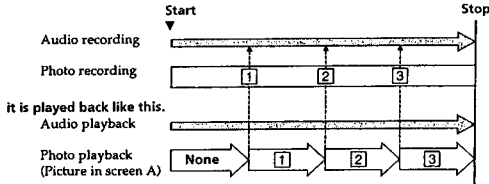

When the recorded photo is reached during audio playback, screen A is replaced by photo 1, 2 or 3.

**Index image on the index display**  
The first recorded photo becomes the index image.

**Note**  
Slow playback and frame-by-frame playback are not possible with an audio track.

Advanced Recording Operations

## Self-timer recording

You can make a recording with the self-timer. This mode is useful when you want to record yourself. The Remote Commander will make recording easier.

- (1) Press MENU in the standby mode.
- (2) Turn the control dial to select  CAMERA, and press the dial.
- (3) Turn the control dial to select SELF TIMER, and press the dial.

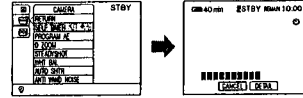

- (4) Start recording.

**To record a movie:**  
Press START/STOP. Self-timer starts counting down from 10 seconds. As the waiting time passes,  decreases every 1 second.



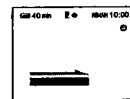

When  all disappear, your camcorder starts recording automatically. As the recording time passes, the bar becomes longer.

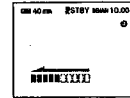

Your camcorder stops recording automatically after 10 seconds.

**To record a photo:**  
Press PHOTO. Self-timer starts counting down from 10 seconds. As the waiting time passes,  decreases every 1 second.



When  all disappear, your camcorder records the photo automatically.

37 38

## Self-timer recording

**To set the waiting and recording time**  
You can select the waiting time from 5, 10, and 15 seconds.  
You can select the recording time of movie from 5, 10, 20, 30 and 60 seconds.

- (1) On the self-timer screen, turn the control dial to select DETAIL, and press the dial.
- (2) Turn the control dial to select the desired time, and press the dial to confirm.

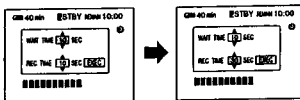

**If you want to see how recording is going**  
Use your camcorder in the mirror mode.



**Note**  
The self-timer recording mode is automatically canceled when:  
- Self-timer recording is done.  
- The POWER switch is set to OFF, PLAY/EDIT, or INTERVIEW.

**To cancel self-timer recording after counting-down has started**  
Press START/STOP or PHOTO again.

**Note on the mirror mode**  
• Since DETAIL is not displayed in the mirror mode, set the waiting and recording time before you turn over the LCD panel.  
• The bar becomes shorter and longer in the opposite direction in the mirror mode.

Advanced Recording Operations

## Shooting backlit subjects (BACK LIGHT)

When you shoot a subject with the light source behind the subject or a subject with a light background, use the backlight function.

- (1) Press BACK LIGHT in the recording or standby mode.  
The  indicator appears on the LCD screen or in the viewfinder.

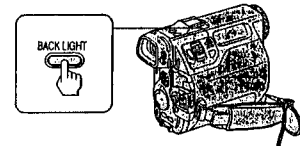

To cancel, press BACK LIGHT again.

**If you press EXPOSURE when shooting backlit subjects**  
The backlight function will be canceled.

39 40

## Using the PROGRAM AE function

You can select PROGRAM AE (Auto Exposure) mode to suit your specific shooting requirements.

### Spotlight mode

This mode prevents people's faces, for example, from appearing excessively white when shooting subjects lit by strong light in the theater.

### Soft portrait mode

This mode brings out the subject while creating a soft background for subjects such as people or flowers.

### Sports lesson mode

This mode minimizes shake on fast-moving subjects such as in tennis or golf.

### Beach & ski mode

This mode prevents people's faces from appearing dark in strong light or reflected light, such as at a beach in midsummer or on a ski slope.

### Sunset & moon mode

This mode allows you to maintain atmosphere when you are recording sunsets, general night views, fireworks displays and neon signs.

### Landscape mode

This mode is for when you are recording distant subjects such as mountains and prevents your camcorder from focusing on glass or metal mesh in windows when you are recording a subject behind glass or a screen.

### 1000/500 Shutter 1000/500 mode

Shutter speed is fixed to 1/1000 or 1/500 seconds. Other parameters such as exposure are adjusted automatically.

This mode minimizes shake on fast-moving subjects. The picture may look dark if you use this mode indoors.

Advanced Recording Operations

## Using the PROGRAM AE function

- (1) Press MENU in the recording or standby mode.
- (2) Turn the control dial to select  CAMERA, and press the dial.
- (3) Turn the control dial to select PROGRAM AE, and press the dial.

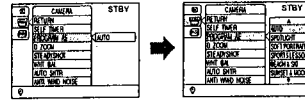

- (4) Turn the control dial to select the desired mode, and press the dial.
- (5) Press MENU.

The menu disappears and the selected PROGRAM AE mode indicator appears on the LCD screen or in the viewfinder.

### To turn the PROGRAM AE function off

Set PROGRAM AE to AUTO in the menu.

### Notes

- In the spotlight, sports lesson and beach & ski modes, you cannot take close-ups. This is because your camcorder is set to focus only on subjects in the middle to far distance.
- In the sunset & moon and landscape modes, your camcorder is set to focus only on distant subjects.

### While WHT BAL is set to AUTO in the menu settings

The white balance is adjusted even if the PROGRAM AE function is selected.

### If you press EXPOSURE when the PROGRAM AE function is selected

You can adjust the exposure.

If you are recording under a discharge tube such as a fluorescent lamp, sodium lamp or mercury lamp

Flickering or changes in color may occur in the following modes. If this happens, turn the PROGRAM AE function off.

- Soft portrait mode
- Sports lesson mode

41

42

## Focusing manually

You can gain better results by manually adjusting the focus in the following cases:

- The autofocus mode is not effective when shooting
  - subjects through glass coated with water droplets
  - horizontal stripes
  - subjects with little contrast with backgrounds such as walls and sky
- When you want to change the focus from a subject in the foreground to a subject in the background
- Shooting a stationary subject when using a tripod

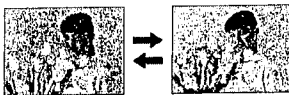

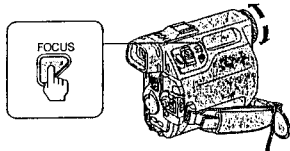

- (1) Press FOCUS lightly in the standby or recording mode. The  indicator appears on the LCD screen or in the viewfinder.
- (2) Turn the focus ring to sharpen focus.



Advanced Recording Operations

### To return to the autofocus mode

Press FOCUS lightly to turn off the ,  or  indicator.

### To record distant subjects

Press FOCUS for more than one second (INFINITY). Your camcorder focuses on distant subjects and the  indicator appears. Use this mode when your camcorder focuses on near objects even though you are trying to shoot a distant object. You can focus manually by turning the focus ring.



### To obtain correct focus

First, focus a subject with the power zoom lever moved toward the "T" (telephoto) position, then adjust the zoom.

### When you shoot close to the subject

Focus at the end of the "W" (wide-angle) position.

### FOCUS changes as follows:

-  when recording a distant subject.
-  when the subject is too close to focus on.

43

44

## Adjusting the exposure manually

You can manually adjust and set the exposure. Adjust the exposure manually in the following cases:

- The subject is backlit
- Bright subject and dark background
- To record dark pictures (e.g. night scenes) faithfully

- (1) In the standby or recording mode, press EXPOSURE. The exposure indicator appears.
- (2) Turn the control dial to adjust the brightness.

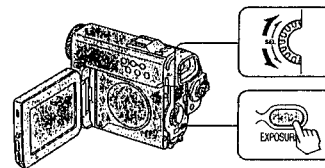

### To return to the automatic exposure mode

Press EXPOSURE again.

### Note

When you adjust the exposure manually, the backlight function does not work.

If you select a PROGRAM AE mode while you are adjusting the exposure manually your camcorder automatically returns to the automatic exposure mode. Press EXPOSURE again and adjust manually.

## Releasing the STEADYSHOT function

The STEADYSHOT function compensates for camera-shake. You can release the STEADYSHOT function when you do not need it. Do not use the STEADYSHOT function when shooting a stationary object using a tripod to obtain more natural picture.

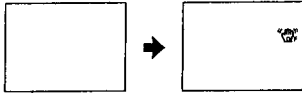

- (1) Press MENU in the recording or standby mode.
- (2) Turn the control dial to select **CAMERA**, and press the dial.
- (3) Turn the control dial to select STEADYSHOT, and press the dial.

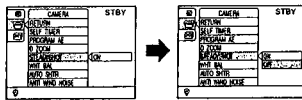

- (4) Turn the control dial to select OFF, and press the dial.
- (5) Press MENU.  
The menu disappears and the **SS** indicator appears on the LCD screen or in the viewfinder.

**To activate the STEADYSHOT function**  
Set STEADYSHOT to ON in the menu.

- Notes**
- The STEADYSHOT function will not correct excessive camera-shake.
  - If you attach a tele-conversion lens or wide-conversion lens, the STEADYSHOT function may not work properly.

Advanced Recording Operations

## Adjusting the white balance manually

You can manually adjust and set the white balance. This adjustment makes white subjects look white and allows more natural color balance. Normally white balance is automatically adjusted.

- (1) Press MENU in the recording or standby mode.
- (2) Turn the control dial to select **CAMERA**, and press the dial.
- (3) Turn the control dial to select WHT BAL, and press the dial.

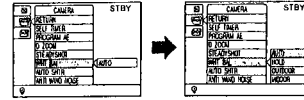

- (4) Turn the control dial to select the desired mode, and press the dial.
  - INDOOR (☀):**
    - Lighting condition changes quickly
    - Too bright place such as photography studios
    - Under sodium lamps or mercury lamps
  - OUTDOOR (☀):**
    - Recording a sunset/sunrise, just after sunset, just before sunrise, neon signs, or fireworks
    - Under a color matching fluorescent lamp
  - HOLD (HOLD):**
    - Recording a single-colored subject or background
- (5) Press MENU.  
The menu disappears and the indicator of selected mode appears on the LCD screen or in the viewfinder.

**To return to the automatic white balance mode**  
Set WHT BAL to AUTO in the menu.

If the picture is being taken in a studio lit by TV lighting  
We recommend that you record in the **☀** indoor mode.

**When you record under fluorescent lighting**  
Use the automatic white balance or hold mode.  
Your camcorder may not adjust the white balance correctly in the **☀** indoor mode.

**In the automatic white balance mode**  
Point your camcorder at a white subject for about 10 seconds after setting the POWER switch to CAMERA to get a better adjustment when:  
• You detach the battery for replacement.  
• You bring your camcorder to the outdoors from the interior of a house, or vice versa.

**If you changed the recording condition in the hold mode**  
Set the white balance to AUTO and reset to HOLD after a few seconds when:  
• You change the PROGRAM AE mode.  
• You bring your camcorder to the outdoors from the interior of a house, or vice versa.

45

46

### — Advanced Playback Operations —

## Displaying two pictures – Picture-in-picture

A desired scene can be displayed in a small picture-in-picture screen during playback. You can display the image in picture-in-picture screen with the playback picture side by side in the same size.

Picture-in-picture



2-picture display



- (1) On the index display, touch **PLAYBACK** and then **PICTURE IN PICTURE**.
- (2) Touch ON.

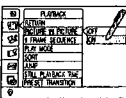

- (3) Touch  to close the menu.  
**PI** appears at the top of the index display.
- (4) Play back the desired track.
- (5) Pause at the scene you want to use in the picture-in-picture screen.  
You can change the scene by turning the control dial.



- (6) Touch **CAPTURE**.  
The scene appears in the picture-in-picture screen.



- (7) Release pause.

**To turn off the picture-in-picture screen**  
Set PICTURE IN PICTURE to OFF.

Advanced Playback Operations

## Displaying two pictures – Picture-in-picture

### Comparing two pictures – 2-picture display

You can display the picture-in-picture image together with another image not only from the same disc but also from other discs.

- (1) Play back the track you want to compare with the picture-in-picture image.
- (2) Touch the picture-in-picture screen.  
The still picture in the picture-in-picture screen appears on the left. The still picture in the currently playing track appears on the right.

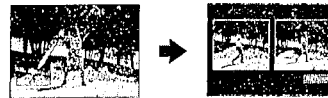

To return to the picture-in-picture display, touch **RETURN**.

### To compare with an image in other discs

After you have captured the picture-in-picture image, change the disc. Do not turn off the power of the camcorder.

**To operate the menu**  
You may use the control dial.

**If PICTURE IN PICTURE is already set to ON**

A previously selected scene appears in the picture-in-picture screen. The picture will be replaced by a new scene when you touch **CAPTURE**.

You can select **PICTURE IN PICTURE** in the shortcut menu  
To turn on the shortcut menu, press **MENU** during playback or playback pause.

**The image in the picture-in-picture screen will disappear:**

- when several minutes have passed after the POWER switch is set to OFF.
- when the power turned off automatically in the CAMERA or INTERVIEW mode.
- when the power source was disconnected.

**Note on digital effect**

Scene transition and picture effects are not applied to the picture-in-picture and 2-picture images.

**When displaying an audio track**

No picture-in-picture screen is displayed.

47

48

## Displaying nine consecutive scenes - 9 FRAME SEQUENCE

You can view a part of a movie as nine still pictures on the screen. This function is useful when you want to look at a fast-moving subject, such as a golf swing, in detail. 9 FRAME SEQUENCE function displays consecutive scenes of every 0.2 second.

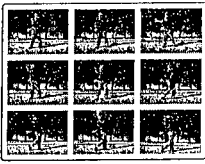

- (1) On the index display, touch **PLAYBACK** and then **9 FRAME SEQUENCE**.

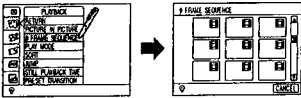

- (2) Touch the desired track.  
You can select a movie track only. If you want to cancel the operation, touch **CANCEL**.

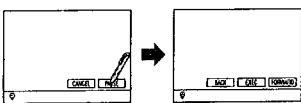

- (3) Touch **PAUSE** at the desired scene.

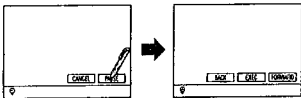

- (4) Adjust the scene position by touching **FORWARD** or **BACK**, and touch **EXEC**.  
Nine still pictures appear on the screen.

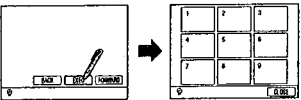

Advanced Playback Operations

## Displaying nine consecutive scenes - 9 FRAME SEQUENCE

### To enlarge one of the pictures to entire screen

- (1) Touch the desired picture.  
If you press **BACK**, the previous frame appears. If you touch **FORWARD**, the next frame appears.

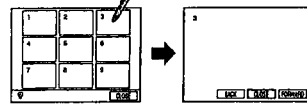

To return to the 9 FRAME SEQUENCE screen, touch **CLOSE**.

### To return to the index display

- (1) Touch **CLOSE**.  
(2) Touch **FINISH**.  
If you continue the 9 FRAME SEQUENCE operation, touch **CONTINUE**.

### To operate the menu

You may use the control dial.

You can select 9 FRAME SEQUENCE in the shortcut menu

To turn on the shortcut menu, press **MENU** during playback or playback pause.

### To select the scene

You may use the control dial. Turn the control dial to select the scene, and press the dial to confirm.

### Note on digital effect

Drawing, scene transition and picture effects are not applied to the nine still pictures or its enlarged picture.

If you select a scene near the end of a track

The number of still pictures displayed may be less than nine.

49

50

## Playing back repeatedly

You can play one track, all tracks in a disc or a portion of a movie (A-B repeat) repeatedly.

### Repeating a track

- (1) On the index display, touch **PLAYBACK** and then **PLAY MODE**.  
(2) Touch **SINGLE REPEAT**.

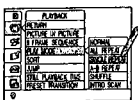

- (3) Touch **X** to close the menu.  
**▶** appears at the top of the index display.

- (4) Play the track to be repeated.

Advanced Playback Operations

### Repeating all tracks in a disc

- (1) On the index display, touch **PLAYBACK** and then **PLAY MODE**.  
(2) Touch **ALL REPEAT**.

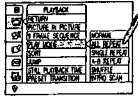

- (3) Touch **X** to close the menu.  
**▶** appears at the top of the index display.

- (4) Play the track to be repeated first.

### Repeating a portion of a movie - A-B repeat

- (1) On the index display, touch **PLAYBACK** and then **PLAY MODE**.  
(2) Touch **A-B REPEAT**.

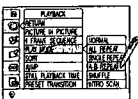

- (3) Touch **X** to close the menu.  
**▶A→B** appears at the top of the index display.

Continued on the next page

## Playing back repeatedly

- (4) Play the track to be repeated.  
**A** of **A|B** flashes.

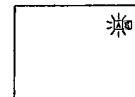

- (5) Press the control dial at the point to start repeating.  
Starting point (A) is set and **B** flashes.  
(6) Press the control dial at the point to finish repeating.  
Finishing point (B) is set. The portion from A to B is repeated.

### To stop repeating

Set **PLAY MODE** to **NORMAL**.

### To operate the menu

You may use the control dial.

### Notes on setting the A-B repeat

- You can set the A and B points by touching **A|B** with the input pen.
- A-B repeat is possible only with movie tracks. If you select other type of track, **A|B** appears, but it cannot be set.
- A-B repeat is possible only within one track. You cannot set A in one track and B in another track.
- A-B repeat is possible with a movie track in a group track.
- If the interval between A and B is shorter than 0.5 second, your camcorder automatically adjust the interval to 0.5 second.

### To cancel A and B points

- Press the control dial. Your camcorder plays from the beginning of the track.
- Stop playback.

51

52



## Playing back in random order – SHUFFLE

You can play the tracks in random order.

- (1) On the index display, touch PLAYBACK and then PLAY MODE.
- (2) Touch SHUFFLE.

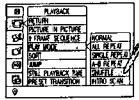

- (3) Touch to close the menu. "SHUF" appears at the top of the index display.

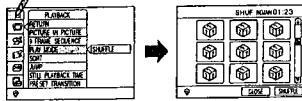

- (4) Touch any track to start playing.  
The index of played tracks resume the index image.

### To stop shuffle play

Touch CLOSE.

If you want to play tracks in another order, touch SHUFFLE.

### To operate the menu

You may use the control dial.

Shuffle play is canceled if you:

- eject the disc.
- turn the POWER switch to OFF.

When the shuffle play is set

The menu does not appear on the index display. (You can turn on the shortcut menu.)

Advanced Playback Operations

## Scanning the top of tracks – INTRO SCAN

You can play the first 3 seconds of all tracks. Photo, memo and title tracks are also played for 3 seconds. Movies shorter than 3 seconds are played for the recorded time.

- (1) On the index display, touch PLAYBACK and then PLAY MODE.
- (2) Touch INTRO SCAN.

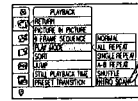

- (3) Touch to close the menu.  
INTRO appears at the top of the index display.

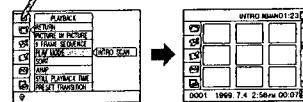

- (4) Play the track to be played first. The first 3 seconds of each track are played.

### To stop scanning

Set PLAY MODE to NORMAL.

### To operate the menu

You may use the control dial.

53

54

## Sorting the tracks

You can sort the tracks so that you can locate or play the desired tracks first.

- (1) On the index display, touch PLAYBACK and then SORT.

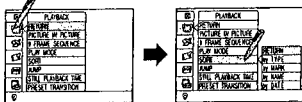

- (2) Touch the desired way of sorting.

The tracks are sorted in the selected order.

**TYPE:** Sorted in the order of movie, photo, memo, audio, group and title. The title track indicating the track type automatically appears.

**MARK:** Marked tracks come first (p. 60).

**NAME:** Sorted in the alphanumeric order of the track names.

**DATE:** Sorted in the order of recorded date.

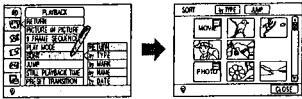

- (3) Play the desired track.  
The title tracks are also played.

### To sort in another order

- (1) Touch the order item (the left item on the top of the SORT screen).
- (2) Touch the desired order.

### To display the desired type of tracks

- (1) Touch JUMP on the SORT screen.  
The type of tracks recorded in the disc are displayed.
- (2) Touch the desired track type.

### To return to the index display

Touch CLOSE.

### To operate the menu

You may use the control dial.

When sorting mode is selected

The menu does not appear on the index display. (You can turn on the shortcut menu.)

Sorting mode is canceled if you:

- eject the disc.
- turn the POWER switch to OFF.

Advanced Playback Operations

## Jumping to the desired track

You can jump to the tracks directly by the title or track name. This function is useful to locate a track when many tracks are recorded in the disc.

- (1) On the index display, touch PLAYBACK and then JUMP.  
The list of title and track names appears.

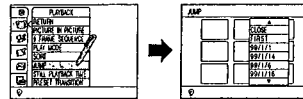

- (2) Touch the desired item in the list.  
To scroll the list, touch or , or turn the control dial.  
The selected track is framed on the index screen.  
**Title:** Tracks created by the title function (p. 82) or recording date automatically recorded in the disc (p. 93).  
**Track name:** Names input on the track information display (p. 60).

### To turn off the list

Touch CLOSE in the list.

### To operate the menu

You may use the control dial.

55

56

## Setting the playing time of still picture tracks

You can select the playing time of still picture tracks such as photo, memo and title from about 1, 3, 5 and 10 seconds. The playing time is set to about 3 seconds as the default setting.

The selected playing time remains until another playing time is selected.

- (1) On the index display, touch **PLAYBACK** and then **STILL PLAYBACK TIME**.

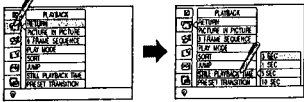

- (2) Touch the desired playing time.
- (3) Touch **X** to close the menu. The index display appears.
- (4) Play the desired track.

To operate the menu  
You may use the control dial.

Advanced Playback Operations

57

58

## Checking the track information

You can check the type, recorded date, data rate, etc., of each track.

Track information display

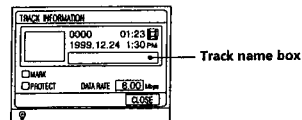

### Displaying the track information

- (1) Touch **EDIT**.
- (2) Touch **TRACK INFO**.

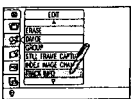

- (3) Touch the desired track. The track information of the track is displayed.

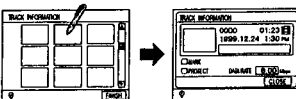

- (4) To close the track information display, touch **CLOSE**.
- (5) Touch **FINISH**. After the **PLEASE WAIT** message, the index display appears.

To operate the menu  
You can use the control dial.

To display the track information display directly  
Select the track on the index display. Touch the track information at the bottom of the screen.

**Note on the data rate**  
The data rate only appears for movie tracks. The average rate appears for the movie tracks recorded in the VP mode.

To check the information of other tracks  
Touch **CONTINUE** in step 5.

59

60

— Editing —

## Checking the disc information

You can check the track numbers, remaining time, etc.

Contents display

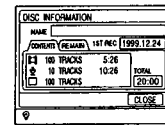

Remain display

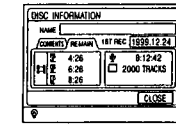

### Displaying the disc information

- (1) Touch **DISC INFO** at the top-right corner of the index display. The disc information display appears.

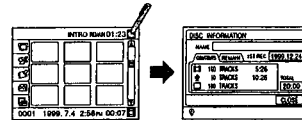

- (2) To check the remaining time or tracks, touch **REMAIN**.
- (3) To close the disc information display, touch **CLOSE**.

### Labelling the disc

You can label a disc using up to 100 characters.

- (1) Touch the **NAME** box on the disc information display.
- (2) Input characters (p. 80).

**Note on the figure in "TOTAL"**

"TOTAL" shows the total playback time of movie, photo, memo and title tracks recorded in the disc. Playback time of each still picture track (photo, memo and title) is the one set in the menu.

**Note on the figure in "REMAIN"**

- "REMAIN" shows the remaining recording time or tracks.
- If you set **REC MODE** to **VP**, you may be able to record longer than the indicated recording time.
- If more than 10 hours remain in the disc, "MORE THAN 10 HRS" appears.

## Checking the track information

### Labelling the track

You can label a track using up to 100 characters.

- (1) Touch the track name box on the track information display.
- (2) Input characters (p. 80).

**Note**

You can record up to 100 characters in one track, and 5000 characters in one disc.

You cannot label the track if:

- the disc is protected.
- the track is protected (✓ is in the **PROTECT** box).

### Marking a track

Mark the tracks which you want to distinguish from others. If you select "MARK" in "SORT" in the **PLAY** menu, those marked tracks are displayed together at the top of the index display.

- (1) Touch the **MARK** box in the track information display to indicate ✓. ✓ icon will be displayed on the marked tracks.

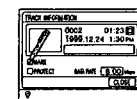

### To cancel the mark setting

Touch the **MARK** box again to erase ✓.

You cannot mark the track if:

- the disc is protected.
- the track is protected (✓ is in the **PROTECT** box).

To mark using the Remote Commander

Select the desired track on the index display, then press **MARK** on the Remote Commander.

To mark tracks during playback

- (1) Press **MARK** on the Remote Commander while playing back the track. The track is played back repeatedly and the confirmation message appears.
- (2) Select **YES** using **↔**, then press **ENTER**.

To cancel the mark setting

Press **MARK** again during playback.

## Checking the track information

### Protecting a track

- Protect important tracks to prevent them from being erased by mistake.
- Touch the PROTECT box in the track information display to indicate ✓.  
 ◯→ icon will be displayed on the protected tracks.

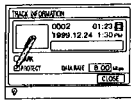

### To release protection

Touch the PROTECT box again to erase ✓.

You cannot protect the track if:  
 the disc is protected.

Editing

## Changing the index image

The first scene becomes the index image for movie tracks. You can change the index image to a desired scene from the movie.

- Touch EDIT.
- Scroll the menu by touching ▲ or ▼, or by turning the control dial.
- Touch INDEX IMAGE CHANGE.
- INDEX IMAGE CHANGE appears at the top of the screen. If you want to cancel changing the index, touch CANCEL.

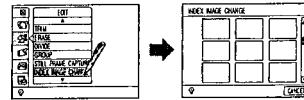

- Touch the desired track. The selected track is played back.
- Touch PAUSE at the scene you want to make into the index image.

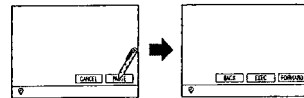

- Touch FORWARD or BACK to adjust the scene position and touch EXEC.
- Touch EXEC.  
 After the PLEASE WAIT message which appears while the change is written in the disc, the INDEX IMAGE CHANGE screen appears.
- Touch FINISH. The index display appears.

### To operate the menu

You can use the control dial.

### You cannot change the index image if:

- the disc is protected.
- the track is protected.

### Note on effects

Drawing, scene transition and picture effects are not applied to the index image.

### You can select INDEX IMAGE CHANGE in the shortcut menu

To turn on the shortcut menu, press MENU during playback or playback pause.

### To select the scene position

You can use the control dial. Turn the control dial to select the position and press the dial to confirm.

### To change the index image of other tracks

Touch CONTINUE in step 7.

61

62

## Changing the index image

### To change the index image during playback or playback pause

- Press INDEX CHANGE on the Remote Commander at the scene you want to make into the index image.  
 The confirmation message appears.
- Select YES using ◀/▶, then press ENTER.  
 After the PLEASE WAIT message, which appears while the change is written in the disc, the camcorder resumes playback.

Editing

## Moving tracks

You can move one track at a time, or several tracks together to the desired position in the disc.



- Touch EDIT.
- Touch MOVE.

TRACK MOVE appears at the top of the screen.

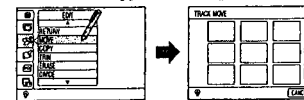

- Touch the desired track.
- Touch the position (between the tracks) where you want to move the track.  
 The track moves to that position.

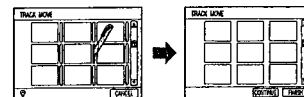

- Touch FINISH.  
 After the PLEASE WAIT message, which appears while the change is written in the disc, the index display appears.

### To move several tracks together

First group the tracks, and then move them.

- Group the tracks you want to move (p. 74).
- Move the tracks as described above.

### To operate the menu

You can use the control dial.

You cannot move the track(s) if:  
 the disc is protected.

### To cancel moving

Touch CANCEL.

### To move other tracks

Touch CONTINUE in step 5, and do steps 3 and 4.

63

64

## Erasing tracks

You can erase one track at a time, or several tracks together. Since the erased tracks cannot be restored, make sure that you can really erase the track.

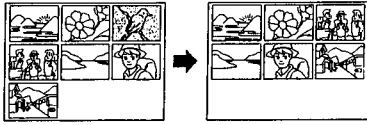

### Erasing one track

- Touch **EDIT**.
- Touch **ERASE**, then **SINGLE**. **TRACK ERASE** appears at the top of the screen.

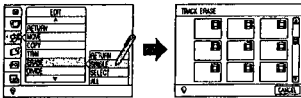

- Touch the desired track. While the selected track is played back repeatedly, the confirmation message appears.
- Touch **YES**. If you do not want to erase the track, touch **NO**.

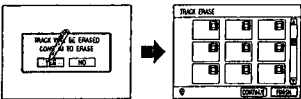

- Touch **FINISH**. After the **PLEASE WAIT** message, which appears while the change is written in the disc, the index display appears. The track is erased and the track next to the erased track is framed.

To operate the menu  
You can use the control dial.

If you erase a group of tracks  
All tracks in the group are erased.

You cannot erase the track(s) if:

- the disc is protected.
- the track is protected.

65

66

## Erasing tracks

### Erasing all tracks in the disc

- All tracks except the protected tracks will be erased.
- Touch **EDIT**.
  - Touch **ERASE**, then **ALL**. The confirmation message appears.

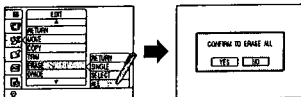

- Touch **YES**. If you do not want to erase the tracks, touch **NO**. After the **PLEASE WAIT** message, which appears while the change is written in the disc, the index display appears. All tracks except the protected tracks are erased.

To cancel erasing  
Touch **CANCEL**.

### Initializing the disc

- All tracks in the disc including the protected tracks will be erased.
- Touch **ADVANCED**.
  - Touch **DISC FORMAT**. The confirmation message appears.

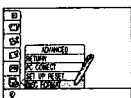

- Touch **YES**. If you do not want to erase the tracks, touch **NO**.

67

68

## Erasing tracks

You can use the **ERASE** button  
Select the track to be erased and press **ERASE**.

To cancel erasing  
Touch **CANCEL**.

To erase other tracks  
Touch **CONTINUE** in step 5.

Note on the remaining disc capacity  
The remaining disc capacity may not increase even if you erase tracks.

### Erasing several tracks together

- Touch **EDIT**.
- Touch **ERASE**, then **SELECT**. **TRACKS ERASE** appears at the top of the screen.

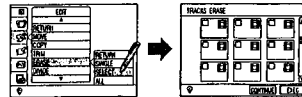

- Touch the box at the top-left of each track you want to erase. ✓ appears in the box.
- Touch **EXEC**. The confirmation message appears.

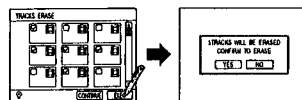

- Touch **YES**. If you do not want to erase the tracks, touch **NO**. After the **PLEASE WAIT** message, which appears while the change is written in the disc, the index display appears. The selected tracks are erased and the first track is framed.

To cancel erasing  
Touch **CANCEL**.

## Copying tracks

You can copy one track at a time, or several tracks together in the same disc.



- Touch **EDIT**.
- Touch **COPY**. **TRACK COPY** appears at the top of the screen.

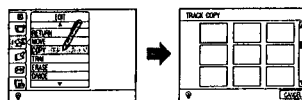

- Touch the desired track.
- Touch the position (between the tracks) where you want to copy the track. The new track appears at that position.

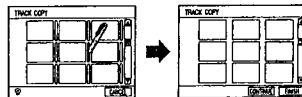

- Touch **FINISH**. After the **PLEASE WAIT** message, which appears while the change is written in the disc, the index display appears.

### To copy several tracks together

- First group the tracks, and then copy them.
- Group the tracks you want to copy (p. 74).
  - Copy the tracks as described above.

To operate the menu  
You can use the control dial.

You cannot copy the track(s) if:  
the disc is protected.

Note on the remaining disc capacity  
The remaining disc capacity may not increase even if you copy tracks.

## Copying tracks

- To not erase a track by mistake  
Copy the track and use the copy for editing.
- To cancel copying  
Touch CANCEL.
- To copy other tracks  
Touch CONTINUE in step 5.

Editing

## Dividing tracks

You can divide movie tracks at the desired position.

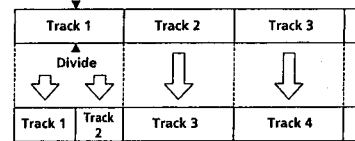

- (1) Touch **EDIT**.
- (2) Touch **DIVIDE**, then **DIVIDE**.  
TRACK DIVIDE appears at the top of the screen.

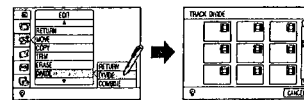

- (3) Touch the desired track.  
The selected track is played back repeatedly.
- (4) Touch **PAUSE** where you want to divide the track.

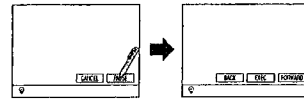

- (5) Adjust the scene position by touching **FORWARD** or **BACK**, then touch **EXEC**.
- (6) Touch **EXEC**.

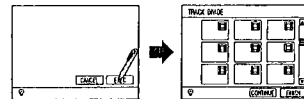

- (7) Touch **FINISH**.  
After the PLEASE WAIT message, which appears while the change is written in the disc, the new track made by dividing appears next to the original track.

To operate the menu  
You can use the control dial.

To cancel dividing  
Touch CANCEL.

69 70

## Dividing tracks

- You cannot divide the track if:
- the track is shorter than about 2 seconds.
  - the disc is protected.
  - the track is protected.

**Note on the dividing position**  
The dividing position is automatically adjusted so that both tracks become at least 0.5 second long.

**To adjust the dividing position**  
You can use the control dial. Turn the control dial to adjust the position and press the dial to confirm.

**Index image of the track made by dividing**  
The scene at the divided position becomes the index image.

**Recorded time of the track made by dividing**  
It is same as the original track.

**To divide other tracks**  
Touch CONTINUE in step 7.

Editing

## Combining the divided track

If the divided track has been moved away from the original track, you cannot recombine them. First line them up in the same order as the original track.

- (1) Touch **EDIT**.
- (2) Touch **DIVIDE**, then **COMBINE**.  
TRACK COMBINE appears at the top of the screen.
- (3) Touch the first track of the divided tracks.  
The confirmation message appears.
- (4) Touch **YES**.  
The selected track in step 3 is combined with the next track.
- (5) Touch **FINISH**.  
After the PLEASE WAIT message, which appears while the change is written in the disc, the index display appears.

**To combine other tracks**  
Touch CONTINUE in step 5.

## Trimming unnecessary scenes

You can trim the unnecessary scenes at the beginning and the end of a movie.  
Since the trimmed scenes cannot be restored, make sure that you really do not want the scenes.

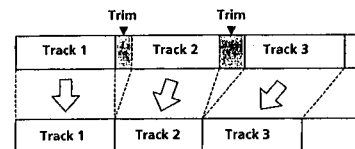

- (1) Touch **EDIT**.
- (2) Touch **TRIM**.  
TRACK TRIM appears at the top of the screen.

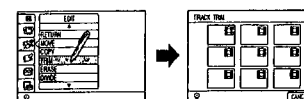

- (3) Touch the desired track.  
The selected track is played back repeatedly.
- (4) Touch **PAUSE** where you want to keep the scenes from.

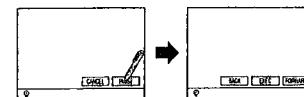

- (5) Adjust the scene position by touching **FORWARD** or **BACK**, then touch **EXEC**.
- (6) Touch **PAUSE** where you want to keep the scenes up to.
- (7) Adjust the scene position by touching **FORWARD** or **BACK**, then touch **EXEC**.  
The scenes you have kept are displayed.

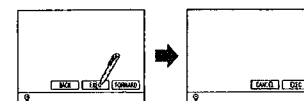

- (8) Touch **EXEC**.
- (9) Touch **FINISH**.  
After the PLEASE WAIT message, which appears while the change is written in the disc, the index display appears.

71 72

## Trimming unnecessary scenes

**To operate the menu**  
You can use the control dial.

**To cancel trimming**  
Touch CANCEL.

**You cannot trim the track if:**

- the track is shorter than about 2 seconds.
- the disc is protected.
- the track is protected.

**Note on the trimming position**  
The trimming position is automatically adjusted so that trimmed track becomes at least 0.5 second long.

**Note on effects**  
Scene transition setting will be canceled if you trim the track.

**To adjust the trimming position**  
You can use the control dial. Turn the control dial to adjust the position and press the dial to confirm.

**To trim other tracks**  
Touch CONTINUE in step 9.

Editing

## Grouping the tracks

You can group the tracks lined up in succession on the index display. Only the first track of the group appears on the index display. This is convenient to move or copy tracks quickly, or to save the index display space when there are many tracks. The  icon appears on the group track on the index display.

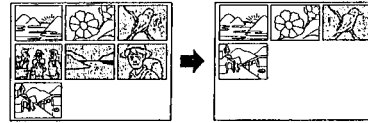

- (1) Touch  EDIT.
- (2) Touch GROUP, then SET.  
TRACK GROUP appears at the top of the screen.

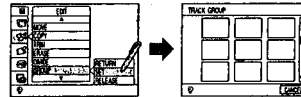

- (3) Touch the first track to be included in the group.
- (4) Touch the last track to be included in the group.
- (5) Touch FINISH.  
After the PLEASE WAIT message, which appears while the change is written in the disc, only the first track of the group is displayed on the index display.

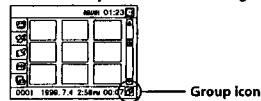

**To operate the menu**  
You can use the control dial.

**To cancel grouping**  
Touch CANCEL.

**You cannot group the tracks if:**  
the disc is protected.

**If you include a protected track in the group**  
The entire group track becomes protected. If you release protecting in the track information display of this group track, all tracks in the group become unprotected tracks.

73 74

## Grouping the tracks

**A group track can be included in the group**  
You can include a group track when making another group. If you release grouping of the tracks, all tracks are released and become individual tracks.

**To group other tracks**  
Touch CONTINUE in step 5.

**You cannot select the following items on the group track**

- PLAY menu
- 9 FRAME SEQUENCE (You can, however, select from the shortcut menu during playback.)
- EDIT menu
  - TRIM
  - DIVIDE
  - STILL FRAME CAPTURE
  - INDEX IMAGE CHANGE
- DRAWING/EFFECT menu
  - DRAWING
  - SCENE TRANSITION
  - PICTURE EFFECT

Editing

## Releasing the tracks from the group

If you want all the tracks to appear individually on the index display after you have moved or copied the tracks in a group, release the group.



- (1) Touch  EDIT.
- (2) Touch GROUP, then RELEASE.
- (3) Touch the grouped track.  
All the tracks in the group appear individually.
- (4) Touch FINISH.  
After the PLEASE WAIT message, which appears while the change is written in the disc, the index display appears.

**To release other group tracks**  
Touch CONTINUE in step 4.

## Making a photo track from a movie

You can make a new photo track of a desired scene in a movie.



- (1) Touch  EDIT.  
Scroll the menu by touching  or , or by turning the control dial.
- (2) Touch STILL FRAME CAPTURE.  
STILL FRAME CAPTURE appears at the top of the screen.

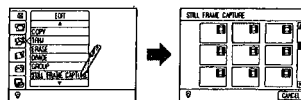

- (3) Touch the desired movie track.  
The selected track is played back.
- (4) Touch PAUSE where you want to capture the scene.

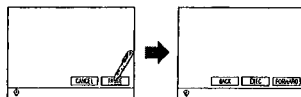

- (5) Adjust the scene position by touching FORWARD or BACK, then touch EXEC.
- (6) Touch EXEC.  
After the PLEASE WAIT message, which appears while the change is written in the disc, the new photo track of the scene appears next to the original movie track.
- (7) Touch FINISH.  
The index display appears.

**To operate the menu**  
You can use the control dial.

**To cancel the operation**  
Touch CANCEL.

**You cannot make a track by capturing a scene if:**  
the disc is protected.

**Note on the picture quality**  
The picture quality of a photo made by this operation is not as good as a recorded photo.

75 76

## Making a photo track from a movie

### Note on effects

Drawing, scene transition and picture effects which have been set on the original movie are not applied to this photo track.

### To adjust the scene position

You can use the control dial. Turn the control dial to adjust the position and press the dial to confirm.



### To continue making photo tracks

Touch CONTINUE in step 7.

— Drawing/Effect —

## Drawing on the picture

You can draw directly on the movie or photo tracks (ADD LAYER), or on a black screen which makes a new memo track (INSERT TRACK). The drawing can be erased (ERASE).

The drawn track has the  icon, and the memo track has the  icon on the index screen.



### Drawing on a picture

- Touch  DRAWING/EFFECT.
- Touch DRAWING, then ADD LAYER. DRAWING LAYER ADD/EDIT appears at the top of the screen.

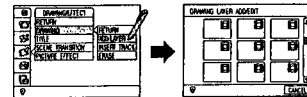

- Touch the desired track. The illustration tool appears while the selected track is played back repeatedly.

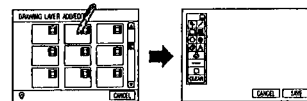

- Draw as you like, then touch SAVE. See page 77 for how to use the illustration tool. After the PLEASE WAIT message, which appears while the change is written in the disc, the DRAWING mode display appears.
- Touch FINISH. The index display appears.

To operate the menu  
You can use the control dial.

To cancel drawing  
Touch CANCEL. All the drawing you made so far is canceled.

You cannot draw if:

- the disc is protected.
- the track is protected.

You can select DRAWING in the shortcut menu  
To turn on the shortcut menu, press MENU during playback or playback pause.

Editing

77 78

## Drawing on the picture

To continue drawing on other tracks  
Touch CONTINUE in step 5.

### Drawing on a black screen (memo track)

You can write up to 24 characters.

- Touch  DRAWING/EFFECT.
- Touch DRAWING, then INSERT TRACK.

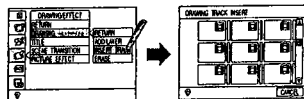

- Touch the position (between the tracks) where you want to insert the memo track. The illustration tool appears on the black screen.
- Draw as you like, then touch SAVE. See page 80 for how to use the illustration tool. After the PLEASE WAIT message, which appears while the change is written in the disc, the DRAWING mode display appears.
- Touch FINISH. The index display appears.

To revise the memo track  
Select ADD LAYER, then the memo track to be revised.

Drawing/Effect

79 80

## Drawing on the picture

### Using the illustration tool

Illustration tool  
Touch the desired tool and draw on the LCD screen using the input pen.

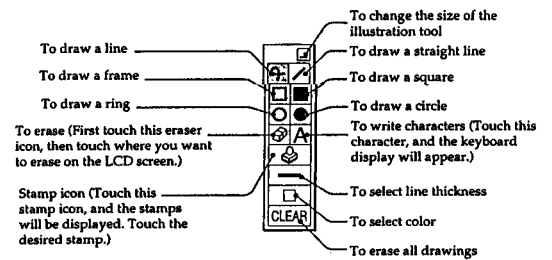

### Keyboard display

Touch the desired characters to write.

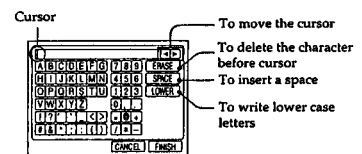

## Drawing on the picture

### Erasing the drawings

Note that the drawings and paintings cannot be restored after being erased. The pictures are not erased by erasing the drawings.

- Touch DRAWING/EFFECT.
- Touch DRAWING, then ERASE. PAINT REMOVE appears at the top of the screen. If you want to cancel erasing, touch CANCEL.

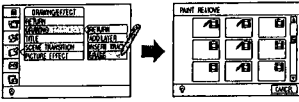

- Touch the desired track. The confirmation message appears while the selected track is played back repeatedly.
- Touch YES. The icon disappears from the track.

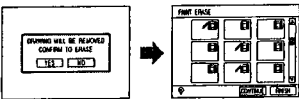

- Touch FINISH. After the PLEASE WAIT message, which appears while the change is written in the disc, the index display appears.

To cancel erasing  
Touch NO.

If you select CLEAR in the illustration tool  
The icon does not disappear. To erase the icon, follow the above steps.

To erase the memo track  
Erase the track by selecting ERASE in the EDIT menu.

To continue erasing the drawing on other tracks  
Touch CONTINUE in step 5.

DRAWING/EFFECT  
Drawing/Effect

81 82

## Switching the tracks with special effects

You can switch the tracks with special effects such as fading in/out. These effects can be applied to the movie and photo tracks only, and are recorded in the disc.

Effects to be applied to the beginning and end of a track

- Fade (in/out)  
The picture fades in from black, and fades out to black.
- Wipe (in/out)  
The picture appears as the black screen opens, and disappears as the black screen closes.
- Mosaic (in/out)  
The picture appears from mosaic, and disappears to mosaic.

Effects to be applied across two tracks

- Cross-fade  
As the previous track fades out, the next track fades in.
- Cross-wipe  
The next track appears turning over the previous track.
- Cross-dissolve  
The next track appears inlaid into the previous track.

Effects to be applied only to the end of a track

- Blackout  
A black screen is displayed at the end of each track.
- Hold  
Each track pauses for a while at the end.

- Touch DRAWING/EFFECT.
- Touch SCENE TRANSITION. SCENE TRANSITION appears at the top of the screen.

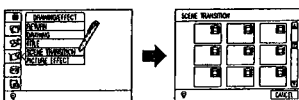

- Touch the desired track.
- Touch the effect and direction for the track to appear.

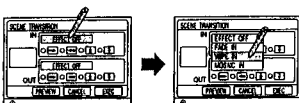

- Touch the effect and direction for the track to disappear.

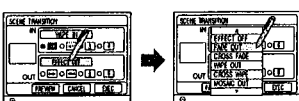

Continued on the next page

DRAWING/EFFECT  
Drawing/Effect

83 84

## Inserting a title track

You can use the title track to locate the tracks, or to categorize the tracks. A title track made on the TITLE INSERT display can be quickly located by sorting or jumping for playback. A title track makes one track. The title track has the icon on the index display.

- Touch DRAWING/EFFECT.
- Touch TITLE. TITLE INSERT appears at the top of the screen.

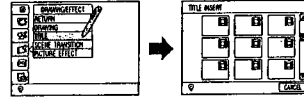

- Touch the position (between the tracks) where you want to insert the title track.
- Touch the box to input the title. The keyboard appears. See page 80 for how to use the keyboard.
- Input the title you like, then touch EXEC. The title you made appears at the selected position.

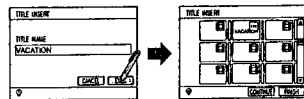

- Touch FINISH. After the PLEASE WAIT message, which appears while the change is written in the disc, the index display appears.

To operate the menu  
You can use the control dial.

To cancel making a title  
Touch CANCEL.

Track name of the title track  
The title track has the same name as the title itself.

If you change the track name on the track information display  
The title automatically becomes what you input on the track information display.

To continue making titles  
Touch CONTINUE in step 6.

## Switching the tracks with special effects

- Touch PREVIEW. The last 5 seconds of the track before the selected track, the selected track itself and the first 5 seconds of the next track will be played back with the selected effects.

- Confirm the playback, then touch BACK.

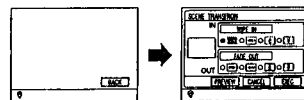

- Touch EXEC.
- Touch FINISH. After the PLEASE WAIT message, which appears while the change is written in the disc, the index display appears.

To not apply the scene transition effect  
Select EFFECT OFF.

To operate the menu  
You can use the control dial.

To cancel setting the effects  
Touch CANCEL. All the settings you made so far is canceled.

Notes on cross-fade, cross-wipe and cross-dissolve effects

- Select the track which appears first when you set these effects.
- These effects are available only when you select a track followed by either a movie or a photo track.
- These effects are canceled:
  - if you set an IN-effect to its succeeding track.
  - if you move the track.
  - if you move or copy other track between the tracks.

Notes on wipe and cross-wipe effects  
Touch the desired direction to switch.

You cannot set switching effects if:  
• the disc is protected.  
• the track is protected.

The switching effects will not be played back on:  
• picture-in-picture, 2-picture and 9 FRAME SEQUENCE (including enlarged picture) displays  
• a photo set to play for one second  
• a very short movie

To continue setting switching effects  
Touch CONTINUE in step 9.



## Switching the tracks with special effects

### Playing back all the tracks with fade or hold effect

If you set the PRESET TRANSITION to FADE or HOLD, your camcorder always plays back discs with fade or hold effect. This setting is not recorded in the disc.

- (1) Touch PLAYBACK on the index display, then touch PRESET TRANSITION.

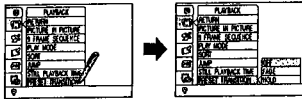

- (2) Touch FADE or HOLD.
- (3) Touch to close the menu. The index display appears.
- (4) Touch the track to be played first. The tracks are played back with the selected effect.

#### To not fade or hold

Select OFF of PRESET TRANSITION.

#### Note

The PRESET TRANSITION setting is kept even if your camcorder is turned off.

If a SCENE TRANSITION effect of the EDIT menu is set to the track The track is played back with the SCENE TRANSITION effect.

#### Note on playback

The PRESET TRANSITION effects will not be played back on:

- a photo set to play for one second
- a very short movie

#### Note on a group track

Each track in the group is played back with the effect.

Drawing/Effect

## Applying the picture effect to the tracks

You can make movie and photo tracks into sepia, black-and-white, mosaic, or slow-motion play by digital processing. You can also set the slow-motion play to a track in addition to other effects. The picture effect setting is recorded in the disc.

- (1) Touch DRAWING/EFFECT.
- (2) Touch PICTURE EFFECT. PICTURE EFFECT appears at the top of the screen.

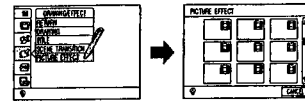

- (3) Touch the desired track.
- (4) Touch the desired effect, then touch PREVIEW. The track will be played back with the selected effect.

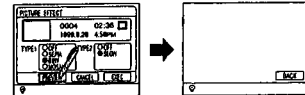

- (5) Confirm the playback, then touch BACK.
- (6) Touch EXEC.
- (7) Touch FINISH. After the PLEASE WAIT message, which appears while the change is written in the disc, the index display appears.

#### To not apply the digital effect on the track

Select OFF.

#### To operate the menu

You can use the control dial.

#### To cancel setting the picture effects

Touch CANCEL. All the settings you made so far are canceled.

You cannot set the picture effects if:

- the disc is protected.
- the track is protected.

#### Note on playback

Sepia, black-and-white (B & W) and mosaic effects will not be played back on picture-in-picture, 2-picture and 9 FRAME SEQUENCE (including enlarged picture) displays.

#### To continue setting picture effects

Touch CONTINUE in step 7.

85 86

## — Customizing Your Camcorder —

### Adjusting the brightness and color of the LCD screen

- (1) In the CAMERA, PLAY/EDIT or INTERVIEW mode, press MENU.
- (2) Touch SET UP.

#### Camera/Interview mode

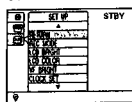

#### Play/Edit mode

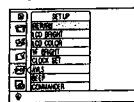

- (3) To adjust the brightness, touch LCD BRIGHT. To adjust the color, touch LCD COLOR. The bar indicator appears.
- (4) Turn the control dial to adjust the brightness or color, then press the dial.



#### Note

You cannot adjust the brightness and color of the LCD screen when the LCD screen is closed.

#### To operate the menu

You can use the control dial to select the menu items.

Customizing Your Camcorder

### Adjusting the brightness of the viewfinder

- (1) In the CAMERA, PLAY/EDIT or INTERVIEW mode, press MENU.
- (2) Turn the control dial to select SET UP and press the dial.

#### Camera/Interview mode

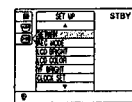

#### Play/Edit mode

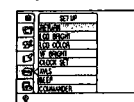

- (3) Turn the control dial to select VF BRIGHT and press the dial. The bar indicator appears.
- (4) Turn the control dial to adjust the brightness while looking into the viewfinder, then press the dial.



#### Note

You cannot adjust the brightness of the viewfinder when the viewfinder is turned off.

87 88

## Resetting the date and time

The default clock setting is set to Eastern Standard Time. If you do not use your camcorder for about four months, the date and time settings may be released (bars may appear) because the vanadium-lithium battery installed in your camcorder will have been discharged. If this happened, charge the vanadium-lithium battery (p. 108) before setting the clock.

First set the year, then the month, the day, the hour and then the minute.

- (1) In the CAMERA, PLAY/EDIT or INTERVIEW mode, press MENU.
- (2) Touch SET UP.

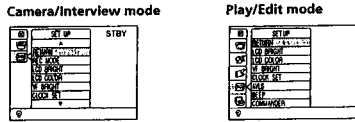

- (3) Touch CLOCK SET.

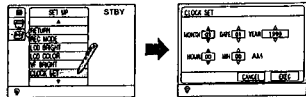

- (4) Turn the control dial to adjust the year, then press the dial.

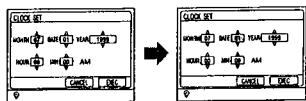

- (5) Set the month, day, hour and minute by turning the control dial and pressing the dial.

- (6) Touch EXEC on the screen. The clock starts to operate.

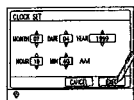

Customizing Your Camcorder

89 90

## Changing the menu settings

To change the settings in the menu, touch the desired item on the LCD screen. The default settings can be partially changed. First, display the main menu, select the icon, the menu item and then the mode.

- (1) In the CAMERA, PLAY/EDIT or INTERVIEW mode, press MENU.

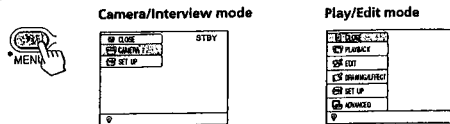

- (2) Touch the desired icon.

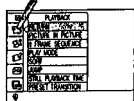

- (3) Touch the desired item.

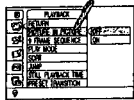

- (4) Touch the desired mode.

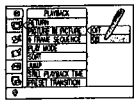

- (5) Repeat steps 2 to 4 to set other items. To go back to step 2, touch RETURN.
- (6) To close the menu, touch or press MENU.

Items in the main menu are displayed with the following icons:

- CAMERA menu
- SET UP menu
- PLAYBACK menu
- EDIT menu
- DRAWING/EFFECT menu
- ADVANCED menu

Customizing Your Camcorder

91 92

## Resetting the date and time

The year changes as follows:

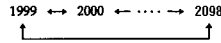

If you do not set the date and time "----" is recorded in the disc.

**Note on the time indicator.**  
The internal clock of your camcorder operates on a 12-hour cycle.  
• 12:00 AM stands for midnight.  
• 12:00 PM stands for noon.

**To operate the menu**  
You can use the control dial to select the menu items.

## Changing the menu settings

**Menu in the CAMERA and INTERVIEW mode** ● is the default setting.

Icon/Item	Mode	Meaning
SELF TIMER*	—	To start recording automatically when the preset waiting time has passed, and stop recording automatically when the preset recording time has passed (p. 38).
PROGRAM AE	—	To suit your specific shooting requirement (p. 41).
D ZOOM	● OFF ON	To deactivate the digital zoom. Up to 10x zoom is carried out. To activate the digital zoom. More than 10x to 40x zoom is performed digitally.
STEADYSHOT	OFF ● ON	To cancel the SteadyShot function (p. 45). Natural pictures are produced when shooting a stationary object with a tripod. To compensate for camera-shake.
WHT BAL	—	To adjust the white balance (p. 46).
AUTO SHTR	OFF ● ON	To deactivate the electronic shutter even when shooting in bright conditions. To automatically activate the electronic shutter when shooting in bright conditions.
ANTI WIND	● OFF —	—
NOISE	ON	To reduce the noise caused by strong wind.
REC MODE*	● SP (8Mbps) VP (VARIABLE) LP (4Mbps)	To record in high quality picture mode. To save the data consumption by adjusting the picture quality depending on the subject. To increase the recording time by reducing the picture quality. (Actual data rate is 3.75 Mbps.)
LCD BRIGHT	—	To adjust the brightness of the LCD screen (p. 87).
LCD COLOR	—	To adjust the color of the LCD screen (p. 87).
VF BRIGHT	—	To adjust the brightness of the viewfinder screen (p. 88).
CLOCK SET	—	To set the date and time (p. 89).

\* You cannot select the item in the INTERVIEW mode.

More than one day after removing the power source The "COMMANDER," "PROGRAM AE" and "WHT BAL" items return to their default settings. The other menu items are held in memory even when the power source is removed.

## Changing the menu settings

Icon/Item	Mode	Meaning
AVLS	● OFF	The sound volume is as adjusted.
	ON	To activate the Automatic Volume Limiter System when the volume is turned up. This works on the headphones and speaker.
BEEP	OFF	To cancel the beep sound.
	● ON	To output the beep when you start/stop recording or press other operation buttons.
REC LAMP	OFF	To turn off the camera recording lamp so that person is not aware of the recording.
	● ON	To turn on the camera recording lamp at the front of the camcorder.
COMMANDER	OFF	To deactivate the Remote Commander to avoid remote control misoperation caused by other VCR's remote control.
	● ON	To activate the Remote Commander supplied with your camcorder.
PICTURE IN PICTURE*	● OFF	To not display the last track index image during recording standby.
	NORMAL	To display the last track index image during recording standby.
AUTO DATE	● OFF	To not make the title track of recording date.
TITLE	ON	The camcorder automatically makes the title track of recording date by day of recording. You can locate this track by jump.
10sec. TRACK*	● OFF	Your camcorder does not renew the track until the recording stops. The entire recording makes one track.
	ON	Your camcorder makes new tracks of 10 seconds while recording a movie. (The last track will be longer than 6 seconds but shorter than 16 seconds.)
START/STOP*	● NORMAL	To start recording by pressing START/STOP and stop recording by pressing it again.
	ANTI GROUND	To record only while you are pressing START/STOP to avoid recording the ground by mistake.

\* You cannot select the item in the INTERVIEW mode.

### Notes on "10sec. TRACK"

- The every track made with the "10sec. TRACK" function has the same recorded time as the first track of the recording.
- If you record for long time in one recording with 10sec. TRACK set to ON, it may take a maximum of 16 minutes to write in the disc after recording.

### Note on REC LAMP

When REC LAMP is set to ON, the red camera-recording lamp on the front of the camcorder may reflect on the subject if it is close. In this case, we recommend you set REC LAMP to OFF.

Customizing Your Camcorder

## Changing the menu settings

### Menu in the PLAY/EDIT mode ● is the default setting.

Icon/Item	Mode	Meaning
PICTURE IN PICTURE	● OFF	To not display the picture-in-picture screen.
	ON	To display a scene in the picture-in-picture screen (p. 47).
9 FRAME SEQUENCE	-	To display successive scenes of a movie as 9 still pictures (p. 49).
PLAY MODE	-	To play back repeatedly or in random order (p. 51, 53, 54).
SORT	-	To play back in the desired order (p. 55).
JUMP	-	To directly call up the desired track on the screen (p. 56).
STILL PLAYBACK TIME	-	To set the playing time of a still picture to 1, 3, 5 or 10 seconds (p. 57).
PRESET TRANSITION	● OFF	To play back all the tracks in the disc with an effect such as fade (p. 85).
	FADE	
	HOLD	
MOVE	-	To move tracks to the desired position (p. 64).
COPY	-	To copy tracks to the desired position (p. 68).
TRIM	-	To erase unnecessary scenes at the beginning and the end of a movie (p. 72).
ERASE	-	To erase tracks (p. 65).
DIVIDE	-	To divide a movie track into two tracks (p. 70).
GROUP	-	To group some tracks (p. 74).
STILL FRAME CAPTURE	-	To make a photo track of a scene in a movie (p. 76).
INDEX IMAGE CHANGE	-	To change the scene of the track to be displayed on the index display (p. 62).
TRACK INFO	-	To display and edit the track information such as recording date (p. 59).
DRAWING	-	To draw pictures on a tracks (p. 78).
	TITLE	To make and insert a title track in the disc for easy locating (p. 82).
SCENE TRANSITION	-	To switch tracks with special effect (p. 83).
PICTURE EFFECT	-	To give a picture a professional look by digital effect (p. 86).
LCD BRIGHT	-	To adjust the brightness of the LCD screen (p. 87).
LCD COLOR	-	To adjust the color of the LCD screen (p. 87).
VF BRIGHT	-	To adjust the brightness of the viewfinder screen (p. 88).
CLOCK SET	-	To set the date and time (p. 89).
AVLS	● OFF	The sound volume is as adjusted.
	ON	To activate the Automatic Volume Limiter System when the volume is turned up. This works on the headphones and speaker.

93

94

## Changing the menu settings

Icon/Item	Mode	Meaning
BEEP	OFF	To cancel the beep sound.
	● ON	To output the beep when you start/stop recording or press other operation button.
COMMANDER	OFF	To deactivate the Remote Commander to avoid remote control misoperation caused by other VCR's remote control.
	● ON	To activate the Remote Commander supplied with your camcorder.
PC CONNECT	-	To transmit the picture data to a computer (p. 101)
SET UP RESET	-	To reset the settings to the default settings.
DISC FORMAT	-	To erase all tracks and initialize a disc (p. 67).

### If you select SET UP RESET

The confirmation message will appear. To reset, select YES. The index screen will appear after a while. Not only the settings you have made in the menu but also those you have made with the operation buttons will be reset to the default settings, except for clock setting.

Customizing Your Camcorder

## Using with Other Equipment

### Dubbing on a tape

- Connect your camcorder to the VCR using the A/V connecting cable supplied with your camcorder.
- Set the input selector on the VCR to LINE, if available.
- (1) Insert a blank tape (or a tape you want to record over) into the VCR, and insert the recorded disc into your camcorder.
  - (2) Set the input selector on the VCR to LINE. For details, refer to the operating instructions of the VCR.
  - (3) Set the POWER switch to PLAY/EDIT.
  - (4) Play back the recorded disc on your camcorder
  - (5) Start recording on the VCR. For details, refer to the operating instructions of the VCR.

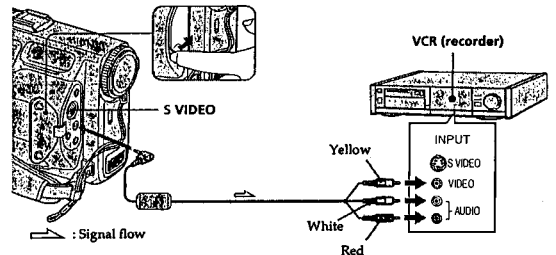

### When you have finished dubbing

Press ■ on both your camcorder and the VCR.

You can edit on VCRs that support the following systems  
 8 mm, Hi8, Hi8c, Digital8, VHS, S-VHS, S-VHS-C, S-VHS-C, S-VHS-C, ED Betamax, ED Betamax, mini DV or DV

### If your VCR is a monaural type

Connect the yellow plug of the A/V connecting cable to the video input jack and the white or the red plug to the audio input jack on the VCR. When the white plug is connected, the left channel audio is output, and the red plug is connected, the right channel audio is output.

Connect using an S video cable (not supplied) to obtain high quality pictures. With this connection, you do not need to connect the yellow (video) plug of the A/V connecting cable.

Connect an S video cable (not supplied) to the S video jacks of both your camcorder and the VCR. This connection produces higher quality pictures.

Be sure to clear the indicators from the screen. If they are displayed, press DSPL not to record the indicators on the dubbed tape.

95

96

## Printing the still picture

You can print a photo by using the video printer (not supplied). Connect the video printer using the A/V connecting cable supplied with your camcorder. Connect it to the AUDIO/VIDEO jack and connect the yellow plug of the cable to the video input of the video printer. Refer to the operating instructions of the video printer as well.

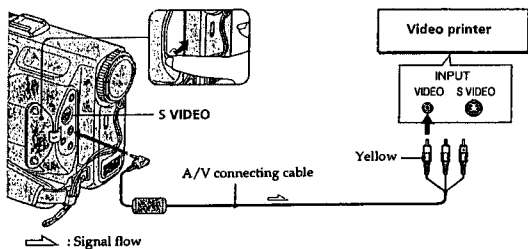

If the video printer is equipped with S video input Use the S video connecting cable (not supplied). Connect it to the S VIDEO jack and the S video input of the video printer.

Using with Other Equipment

## Listening to an audio MD

Your camcorder can play an audio MD. You can enjoy better sound if you use headphones (not supplied).

- (1) Insert the audio MD.
  - (2) Set the POWER switch to PLAY/EDIT.
- The operation screen for audio MDs appears.
- (3) Touch the desired title or track.
  - (4) Press ►II to start playing.

### Using the operation screen

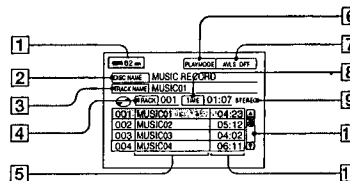

- 1 Battery remaining time
- 2 Disc title\*
- 3 Current track title\*
- 4 Current track number
- 5 Track titles\*
- 6 Touch to change the play mode. A play mode indicator such as ◀ appears to the left.
- 7 Touch to turn AVLS on or off.
- 8 Playing time of current track
- 9 Recording mode (stereo or monaural)
- 10 Scroll bar
- 11 Play time of each track

\* displayed only if it is recorded in the MD.

### Notes on headphones

Use headphones of the stereo mini plug type.

### To select a track

You can use the control dial. Turn the control dial to select the track, and press the dial to start playing.

### Note on the menu

You cannot control the menu when an audio MD is in your camcorder.

### If you use your camcorder while jogging

Continuous vibration caused by jogging may result in intermittent playback.

97

98

## Listening to an audio MD

### Various ways of playback

To	Do this
pause playback	Press ►II. Press again to release pause.
go to the next track	Press ► briefly.
go back to the top of the current track	Press ◀ briefly.
fast-forward	Keep ►► pressed.
fast-reverse	Keep ◀◀ pressed.
stop playback	Press ■.
turn up the volume	Press VOL +.
turn down the volume	Press VOL -.

### To fast-forward or fast-reverse at high speed

Keep pressing ►► or ◀◀ during pause. You will hear no sound.

### To activate AVLS (Automatic Volume Limiter System)

Touch AVLS and set to ON. If you try to turn up the volume higher than a certain level, AVLS appears on the LCD screen. You cannot turn up the volume any more. The AVLS function reduces sound leakage from headphones and pressure on your ears and also helps you remain aware of your surroundings so you can avoid mishaps.

Using with Other Equipment

### Playing repeatedly or in random order

You can play one track or all tracks repeatedly, or all tracks in random order.

- (1) Insert the audio MD and set the POWER switch to PLAY/EDIT. The operation screen for audio MDs appears.
- (2) Touch PLAY MODE repeatedly until the desired play mode icon appears to the left.

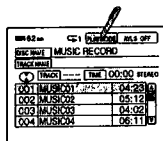

Icon	Play mode
None (normal play)	All the tracks are played once.
◀ (single repeat)	A signal track is played repeatedly.
◀◀ (all repeat)	All the tracks are played repeatedly.
◀SHUF (shuffle repeat)	All the tracks are played repeatedly in random order.

## Viewing on the computer display

Your camcorder is capable of sending the movies or photos recorded in the MD DATA2 disc to a World Wide Web (WWW) homepage.

You can view the pictures using the browser software such as Internet Explorer or Netscape Navigator by connecting the 10BASE-T terminal of the connecting cord to a computer.

### Homepage



### Recommended browser

- Microsoft Internet Explorer Ver. 4.0 or greater
- Netscape Navigator Ver. 4.5 or greater

### Notes on the camcorder's homepage

- No interview, group, or memo track is displayed. To view the grouped tracks, first disconnect the computer and then release the group.
- No scene transition, picture effect, drawing is displayed.
- No audio track is sent to the computer.

### To play the photo on the computer

The format of the photo turns into JPEG format.

### To play the movie on the computer

The format of the movie turns into Quick Time format (Motion JPEG) on the camcorder's homepage. To play the movie, Apple Quick Time Ver. 3.0 or greater is required.

### Data size

Photo: about 96 kilobytes per track

Movie: about 8 kilobytes minimum, about 96 kilobytes maximum per frame

Microsoft, Windows, Widows NT, Microsoft Internet Explorer logo are registered trademarks of Microsoft Corporation in the United States and other countries.

Apple, Macintosh, Quick Time are trademarks licensed to Apple Computer, Inc., registered in the U.S.A. and other countries.

Netscape Navigator is a trademark of Netscape Communications Corporation.

All other product names mentioned herein may be the trademarks or registered trademarks of their respective companies.

99

100

## Viewing on the computer display

### Step 1 Setting the address for your camcorder

Set the camcorder's address so that you can access your camcorder from the computer. You do not need to reset the address as long as the computer is used under same environment.

- Touch **ADVANCED**, then **PC CONNECT**.
- Touch **SET UP**.

The screen to set IP address, etc. appears.

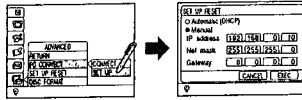

- Touch **MANUAL** to put a black dot in the white circle. You can set the IP address, net mask, and gateway.
- Set the IP address. You can keep as it is, or put any desired number. This number becomes your camcorder's homepage address. Net mask: For example, set to 255.255.255.0. Gateway: If you are not sure, set to 0.0.0.0.

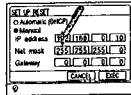

- Touch **EXEC**. If you change the setting, touch **CANCEL** and repeat from step 1.
- Touch **CONFIRM**. The camcorder automatically turns off and on again. The setting is completed.

#### To set the IP address on the computer

Set the IP address on the computer in accordance with your camcorder. In case of the above setting (192.168.0.10), set as follows:  
IP address: 192.168.0.1  
Net mask: 255.255.255.0  
Gateway: 0.0.0.0

**To operate the menu**  
You can use the control dial.

**To return to the previous screen**  
Touch **RETURN**.

**The first digit of IP address**  
Changes ranging from 0 to 223.

Using with Other Equipment

## Viewing on the computer display

### Net mask

Changes in the order of 255 - 254 - 252 - 248 - 240 - 224 - 192 - 128 - 0 - 255.

### Using the DHCP server of the network

You can set the address automatically. Touch **AUTO** in step 3 and proceed to step 5.

### Step 2 Connecting the camcorder to the computer

Use a commercially available cross cable.

- Connect the connecting cable to the camcorder.

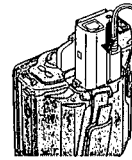

- Connect the camcorder to the computer using a commercially available cross cable.

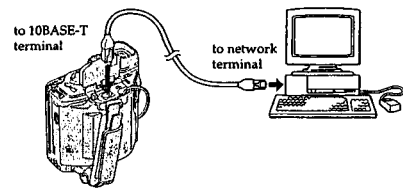

### Notes

- Turn off the power of the camcorder and computer before connection.
- You cannot shut the battery lid when the cross cable is connected.

### Note on the type of the computer's network terminal

Either an exclusive 10BASE-T terminal or a 10BASE-T/100BASE-T compatible terminal can be connected.

101 102

## Viewing on the computer display

### Viewing the pictures

A browser software such as Internet Explorer or Netscape Navigator is required to view the pictures on the computer.

- Turn on the computer.
- Insert the recorded MD DATA2 disc in the camcorder.
- Set the **POWER** switch to **PLAY/EDIT**.
- Touch **ADVANCED**, then **PC CONNECT**.
- Touch **CONNECT**.

The homepage address appears on the camcorder's screen.

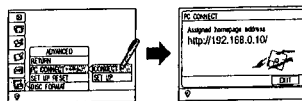

- Operate the browser software on the computer and input the address displayed in step 5. The homepage with pictures recorded in the MD DATA2 disc appears on the computer screen.

### Note

Do not access the camcorder's homepage from more than one computer at the same time. Doing so may cause malfunction.

### If the "Connect the network cable" message appears

Make connection as described in "Step 2. Connecting the camcorder to the computer."

### Caution

Do not change the disc while the homepage is displayed. When you change the disc, close the homepage first.

If the picture in the previous disc appears on the computer display after you have changed the disc, check connection and press the **RELOAD** button of the browser.

### If you do not have the recommended browser

You may be able to access by adding "/text.htm" at the end of the address (example: http://192.168.0.10/text.htm).

### Note on the browser software

Do not set the proxies. You may not be able to access your camcorder.

Using with Other Equipment

## Viewing on the computer display

### Homepage of your camcorder

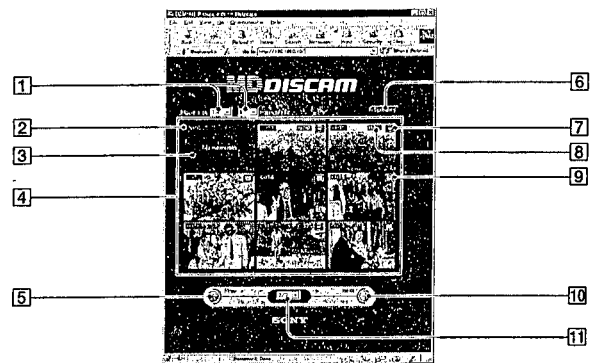

- You can customize the index image of the movie on the index display. Picture size: 624 x 380, 304 x 240, 144 x 120. Number of frames per second: 30, 15, 5, 2, 1.
- Track number
- Title track
- Click the index image, another window will open.
- Go back to previous page.
- Go to the browser page of text only
- Movie track
- Playback time
- Photo track
- Go to next page
- Jump to the designated page

### To close the homepage

- Quit the browser on the computer.
- Touch **EXIT** on the homepage on your camcorder's screen.
- Turn off your camcorder.

103 104

## Precautions and maintenance information

### Precautions

#### Operation

- Operate your camcorder on 7.2 V (battery pack) or 8.4 V (AC adaptor/charger).
- For DC or AC operation, use the accessories recommended in the operating instructions.
- Keep the POWER switch set to OFF when you are not using your camcorder.
- Do not wrap your camcorder in a towel, for example, and operate it. Doing so may cause heat to build up inside.
- Keep your camcorder away from strong magnetic fields or mechanical vibration.
- Keep your camcorder away from TV and AM receivers. TV and AM receivers may cause noise in recording.
- Pass the microphone and remote cords under the flap of the grip strap so that they are not included in the picture, especially when using a wide conversion lens.
- Adjust the angle of the LCD screen not to reflect the sun. The LCD screen reflects a strong light, it is difficult to look and not good for your eyes.
- Do not shoot the sun directly. Doing so may cause malfunction of your camcorder.
- You may hear intermittent sound during operation. This is due to inherent nature of the MD and not a malfunction.

#### Handling

- If any solid object or liquid gets inside the casing, unplug your camcorder and have it checked by a Sony dealer before operating it any further.
- Avoid rough handling or mechanical shock. Be particularly careful of the lens.
- Do not touch the lens in the disc compartment. If the lens becomes dirty, playback may not be performed or pictures may dropout. To keep the lens away from dust, keep the disc lid shut except when you insert or eject a disc.
- To attach a tripod, use the supplied tripod attachment. If you do not use the tripod attachment, make sure that the tripod is securely attached and stable.
- Do not let sand get into your camcorder. When you use your camcorder on a sandy beach or in a dusty place, protect it from the sand or dust. Sand or dust may cause your camcorder to malfunction, and sometimes this malfunction cannot be repaired.

#### Safety

- When a conversion lens is attached, do not look at the sun directly.
- If you have skin trouble after using the eyecup, stop using your camcorder and consult a doctor.
- Keep the input pen, the ferrite cores and the plastic tie of the cables out of the reach of children to prevent children from swallowing them.

#### Moisture condensation

If the camcorder is brought directly from a cold place to a warm place, moisture may condense inside and outside the camcorder. Using the camcorder in this condition may result in malfunction of the camcorder. If moisture condensation occurs, remove the battery, turn off the camcorder, and leave it for about one hour with the battery compartment open.

Additional Information

105

106

## Precautions and maintenance information

### Battery pack

- Use only the specified charger or video equipment with the charging function.
- To prevent accident from a short circuit, do not allow metal objects to come into contact with the battery terminals.
- Keep the battery pack away from fire.
- Never expose the battery pack to temperatures above 140°F (60°C), such as in a car parked in the sun or under direct sunlight.
- Keep the battery pack dry.
- Do not expose the battery pack to any mechanical shock.
- Do not disassemble nor modify the battery pack.
- Attach the battery pack to video equipment securely.
- Charging while some capacity remains does not affect the original battery capacity.
- The battery pack is not resistant to water. Do not wet the battery pack.
- Unless you use the battery pack for a long period, store the battery pack after you charge it fully and use it completely once a year.
- Store the battery pack in a cool, dry place.

### Dry batteries

- To avoid possible damage from battery leakage or corrosion, observe the following:
- Be sure to insert the batteries with the + - polarities matched to the + - marks.
- Dry batteries are not rechargeable.
- Do not use a combination of new and old batteries.
- Do not use different types of batteries.
- Current flows from batteries when you are not using them for a long time.
- Do not use leaking batteries.

### If batteries are leaking

- Wipe off the liquid in the battery compartment carefully before replacing the batteries.
- If you touch the liquid, wash it off with water.
- If the liquid get into your eyes, wash your eyes with a lot of water and then consult a doctor.

### Remote Commander

The supplied Remote Commander operates only this camcorder and cannot operate other model. It is not possible to operate this camcorder with a Remote Commander supplied with other model.

If any problem occurs, unplug your camcorder and contact your nearest Sony dealer.

Additional Information

107

108

## Precautions and maintenance information

### Note on moisture condensation

- Moisture may condense when you bring your camcorder from a cold place into a warm place (or vice versa) or when you use your camcorder in a hot place as follows:
- You bring your camcorder from a ski slope into a warm place.
  - You bring your camcorder from an air-conditioned car or room into a hot place outside.
  - You use your camcorder after a squall or a rain shower.
  - You use your camcorder in a place with high temperature and humidity.

### How to prevent moisture condensation

When you bring your camcorder from a cold place into a warm place, put your camcorder in a plastic bag and tightly seal it. Remove the bag when the air temperature inside the plastic bag has reached the surrounding temperature (after about one hour).

### LCD screen (touch panel)

- Use only the supplied input pen. Using another pen may damage the touch panel.
- Do not push the LCD screen too hard. Doing so may cause uneven color or malfunction of the LCD screen.
- If your camcorder is used in a cold place, a residual image may appear on the LCD screen. This is not a malfunction.
- The back of the LCD panel may heat up during operation. This is not a malfunction.
- Do not grab the LCD screen when you move or carry your camcorder. Doing so may cause malfunction of the LCD screen.

### AC adaptor/charger

- Unplug the AC adaptor/charger from the wall outlet when you are not using the AC adaptor/charger for a long time. To disconnect the power cord, pull it out by the plug. Never pull the power cord itself.
- Do not operate the AC adaptor/charger with a damaged cord or if the AC adaptor/charger has been dropped or damaged.
- Replace the AC adaptor/charger with model AC-VQ800 only, if replacement is necessary.
- Do not bend the power cord forcibly, or place a heavy object on it. This will damage the cord and may cause fire or electrical shock.
- Prevent metallic objects from coming into contact with the metal parts of the connecting section. If this happens, a short may occur and the AC adaptor/charger may be damaged.
- Always keep metal contacts clean.
- Do not disassemble the AC adaptor/charger.
- Do not apply mechanical shock or drop the AC adaptor/charger.
- While the AC adaptor/charger is in use, particularly during charging, keep it away from AM receivers and video equipment. It may disturb AM reception and video operation.
- The AC adaptor/charger becomes warm during use. This is not a malfunction.
- Do not place the AC adaptor/charger in locations that are:
  - Extremely hot or cold
  - Dusty or dirty
  - Very humid
  - Vibrating

## Precautions and maintenance information

### Maintenance

#### Camcorder

Clean the camcorder body with a dry soft cloth, or a soft cloth lightly moistened with a mild detergent solution. Do not use any type of solvent which may damage the finish.

#### Lens

Clean the lens with a commercially available blower.

#### LCD screen

If fingerprints or dust make the LCD screen dirty, we recommend using a LCD Cleaning Cloth (not supplied) to clean the LCD screen.

### Charging the vanadium-lithium battery in your camcorder



Your camcorder is supplied with a vanadium-lithium battery installed so as to retain the date and time, etc., regardless of the setting of the POWER switch. The vanadium-lithium battery is always charged as long as you are using your camcorder. The battery, however, will discharge gradually if you do not use your camcorder. It will be completely discharged in about four months if you do not use your camcorder at all. Even if the vanadium-lithium battery is not charged, it will not affect the camcorder operation. To retain the date and time, etc., charge the battery if it is discharged.

#### Charging the vanadium-lithium battery:

Connect your camcorder to house current using the AC adaptor/charger supplied with your camcorder, and leave your camcorder with the POWER switch turned off for more than 24 hours.

### Calibrating the LCD screen (touch panel)

If the touch panel does not react correctly when you touch it, calibrate the touch panel.

- (1) Set the POWER switch to OFF.
- (2) Eject the disc.
- (3) If you have connected other equipment, disconnect them.
- (4) Open the LCD panel.
- (5) While pressing DSPL and  together, set the POWER switch to PLAY/EDIT.
- (6) Touch the  marks displayed on the LCD screen one by one.



- (6) Turn the LCD panel over and close it to the camcorder body.
  - (7) Touch the  marks displayed on the LCD screen one by one.
  - (8) Touch FINISH.
- The index display appears.

## Usable MiniDiscs

### Structure of MiniDisc

The 2.5-inch MiniDisc (MD) is compact and easy to handle requiring less caution as it is encased in a plastic cartridge that looks like a 3.5-inch diskette.

### Disc variation

MiniDiscs come in three types: MDs to enjoy music, MD DATA and MD DATA2 discs to record computer data, etc. Your camcorder uses MD DATA2 disc to record pictures.



**MD DATA2 disc**  
Records and plays digital data of moving pictures, etc.



**MD DATA disc**  
Records and plays digital data of computers, etc.



**Audio MDs**  
Comes in two types: pre-mastered (pre-recorded) and recordable (blank).  
Premastered MDs are played like regular CDs.

"MD DATA" and "MD DATA2" are registered trademarks of Sony Corporation.  
MD VIEW is a registered trademark of Sony Corporation for MD DATA2 discs.

### Usable MDs with your camcorder

- For recording and playing audio and picture: MD DATA2
- For playing audio only: Audio MD

You cannot use any other discs with your camcorder.

### Notes on MDs

The MiniDisc (MD) is easy to handle requiring less caution about dust or fingerprints as it is encased in a plastic cartridge. However, if the cartridge is dusty or warped, a malfunction may occur. To keep the quality of the picture and sound, handle the MD as follows.

- Do not open the shutter to expose the MD. Close the shutter immediately if the shutter opens.

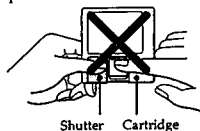

- Do not leave the MD in a location near heat sources, or in a place subject to direct sunlight. Do not leave the MD where sand may get into the MD such as at the beach.
- Wipe the disc cartridge with a dry cloth to remove dirt.

Additional Information

109

## Usable MiniDiscs

### System limitations of the MD

The recording system in your camcorder is radically different from those used in cassette and DAT decks and the system has limitations as described below. Note, however, that these limitations are due to the inherent nature of the MD recording system itself and not to mechanical causes.

The remaining recording time does not increase even after erasing numerous short tracks.  
Tracks under 8 seconds long are not counted, so erasing them may not increase the recording time.

It takes a long time to save or edit pictures.  
Saving and editing on a disc which has hundreds of recorded pictures will take a long time.

The total recorded time and the remaining time on the MD may not reach the maximum recording time.  
Repeated editing may reduce the recordable time of the disc.

The picture or sound may dropout while fast-forwarding or reversing the edited tracks.  
Tracks created through editing may exhibit picture or sound dropout during fast-forwarding or reversing because high-speed playback takes more time to search the position on the disc when the tracks are scattered on the disc.

### Notes

- Your camcorder conforms to the Video MD format.

**Video MD**

- An MD recorded by equipment without bearing Video MD logo cannot be used on your camcorder.
- An MD recorded a video signal other than NTSC system cannot be used on your camcorder.

110

## Warning indicators and messages

If indicators and messages appear on the LCD screen or in the viewfinder, check the following:  
See the page in parentheses for more information.

### Warning indicators

The battery is dead or nearly dead

Flashing:  
• The battery is nearly dead.

Fast flashing:  
• The battery is dead.  
Depending on conditions, the indicator may flash, even if there are 5 to 10 minutes remaining.

You need to eject the disc

Slow flashing:  
• The write-protect tab on the disc is out.

Fast flashing:  
• The disc is full.

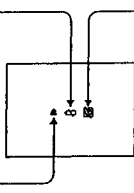

Warning indicator as to disc

Slow flashing:  
• Remaining disc is less than 15 seconds.  
• Remaining disc is less than 5 minutes in the interview recording mode.  
• No disc is inserted.  
• The write-protect tab on the disc is out.

Fast flashing  
• The disc is full.

## Warning indicators and messages

### Warning messages

Warning messages appear on the LCD screen with the respective warning indicators. Main warning messages are listed below.

- CHANGE THE BATTERY (p. 10)
- THIS BATTERY IS OLD PLEASE CHANGE
- FOR "InfoLITHIUM" BATTERY ONLY (p. 10)
- DISC IS FULL
- INSERT A DISC (p. 16)
- PLEASE SET THE CLOCK TIME (p. 89)
- CANNOT RECORD ON AUDIO MD (p. 109)
- CANNOT USE MD DATA DISC (p. 109)
- THIS DISC IS PLAY ONLY
- EJECT ENABLED
- DISC LID IS OPEN (p. 16)
- TOO MANY CHARACTERS (p. 60)
- THIS TRACK IS PROTECTED (p. 61)
- CAN NOT RECORD ON AUDIO MD
- DISC ERROR (p. 114)
- PLEASE CHECK THE BATTERY
- HIGH TEMPERATURE REMOVE THE BATTERY AND WAIT A WHILE TO COOL DOWN
- CANNOT OPEN DISC LID WHILE RECORDING
- THIS DISC IS BLANK AUDIO MD
- DISC FORMAT ERROR CHANGE DISC PLEASE (p. 110)
- MEMORY OVER (p. 114)

Additional Information

116

117

## Using your camcorder abroad

You can use your camcorder in any country or area with the AC adaptor/charger supplied with your camcorder within 100 V to 240 V AC, 50/60 Hz.

Use a commercially available AC plug adaptor [a], if necessary, depending on the design of the wall outlet [b].

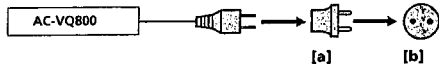

Your camcorder is an NTSC system based camcorder. If you want to view the playback picture on a TV, it must be an NTSC system based TV with the AUDIO/VIDEO input jack.

The following shows TV color systems used overseas.

### NTSC system

Bahama Islands, Bolivia, Canada, Central America, Chile, Colombia, Ecuador, Jamaica, Japan, Korea, Mexico, Peru, Surinam, Taiwan, the Philippines, the U.S.A., Venezuela, etc.

### PAL system

Australia, Austria, Belgium, China, Czech Republic, Denmark, Finland, Germany, Great Britain, Holland, Hong Kong, Italy, Kuwait, Malaysia, New Zealand, Norway, Portugal, Singapore, Slovak Republic, Spain, Sweden, Switzerland, Thailand, etc.

### PAL-M system

Brazil

### PAL-N system

Argentina, Paraguay, Uruguay

### SECAM system

Bulgaria, France, Guyana, Hungary, Iran, Iraq, Monaco, Poland, Russia, Ukraine, etc.

— Quick Reference —

## Identifying the parts and controls

### Camcorder

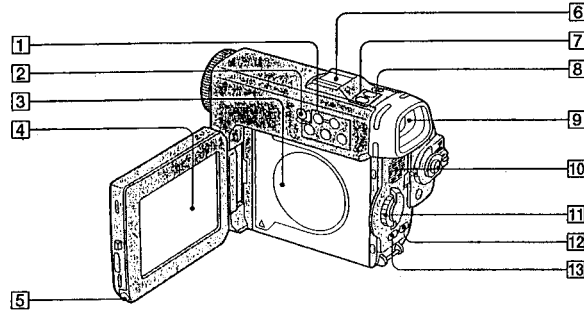

- |   |                                 |
|---|---------------------------------|
| 1 Video/audio control buttons (p. 32, 99)<br>■ (stop)<br>◀ (reverse)<br>▶ (playback/pause)<br>▶▶ (Fast-forward) | 6 Accessory shoe                |
| 2 ● AUDIO REC (recording) (p. 36)   | 7 VOL (volume) buttons (p. 33)  |
| 3 Disc lid (p. 16)  | 8 DSPL (DISPLAY) button (p. 34) |
| 4 LCD screen/touch panel (p. 18, 25)  | 9 Viewfinder (p. 26)            |
| 5 Input pen (p. 18)   | 10 Speaker (p. 33)              |
|   | 11 Control dial (p. 21)         |
|   | 12 EXPOSURE button (p. 44)      |
|   | 13 MENU button (p. 21)          |

Quick Reference



This mark indicates that this product is a genuine accessory for Sony video products. When purchasing Sony video products, Sony recommends that you purchase accessories with this "GENUINE VIDEO ACCESSORIES" mark.

Attaching the shoulder belt (supplied)



120

121

## Identifying the parts and controls

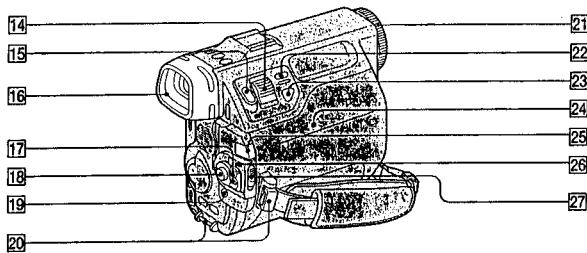

- |                                     |  |
|-------------------------------------|--|
| 14 Power zoom lever (p. 27)         | 21 Focus ring (p. 43)                  |
| 15 PHOTO button (p. 22, 36)         | 22 BACK LIGHT button (p. 40)           |
| 16 Eyecup                           | 23 FOCUS button (p. 43)                |
| 17 POWER switch (p. 22, 30, 36)     | 24 Battery compartment (p. 14)         |
| 18 START/STOP button (p. 22)        | 25 Cord shutter (p. 15)                |
| 19 ERASE button (p. 29, 33)         | 26 LOCK switch (p. 23)                 |
| 20 Hooks for shoulder belt (p. 121) | 27 OPEN (BATT) (battery) lever (p. 14) |

Attaching the supplied tripod attachment

- (1) Hook the tripod attachment to the rear of the camcorder.
- (2) Fasten the screw.

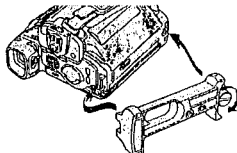

Make sure that you detach the tripod when you change the disc. However, you can change the disc with the tripod attachment attached to the camcorder.

## Identifying the parts and controls

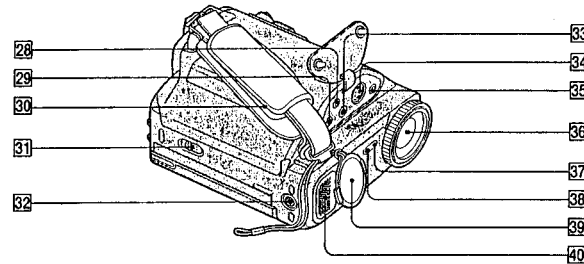

- |   |  |
|---|--|
| 28 REMOTE jack<br>Connects the remote control cable of a tripod or video flash (not supplied).  | 33 AUDIO/VIDEO output jack (p. 35)   |
| 29 (headphones) jack  | 34 S VIDEO output jack (p. 35)   |
| 30 Grip strap (p. 22)   | 35 MIC jack (PLUG IN POWER)<br>Connect an external microphone (not supplied). This jack also accepts a "plug-in-power" microphone. |
| 31 DISC EJECT lever (p. 16)   | 36 Lens  |
| 32 Tripod receptacle<br>Make sure that the length of the tripod screw is less than 1/4 inch (7.5 mm). Otherwise, you cannot attach the tripod securely and the screw may damage your camcorder. If you cannot attach the tripod, use the supplied tripod attachment (p. 122). | 37 Remote sensor   |
|   | 38 Camera recording lamp (p. 22)   |
|   | 39 Lens cap (p. 22)  |
|   | 40 Microphone (p. 23)  |

If you use the headphones  
No sound will be heard from the speaker.

Quick Reference

122

123



## Identifying the parts and controls

### How to affix the ferrite cores

The camcorder is supplied with ferrite cores. Use them to cables as shown in the diagrams below. You must affix the ferrite cores to comply with Part 15 of the FCC Rules.

- (1) Wind the cable round the ferrite core once.



- (2) Fasten the catch.

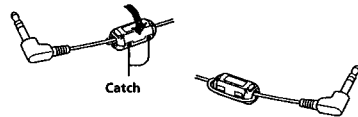

**Headphones and external microphone**  
Use the supplied small ferrite cores.

**Audio connecting cable**  
Use the supplied large ferrite core. Connect the plug which the ferrite core is attached to the camcorder.

#### Notes

- Attach the ferrite cores as close to the plug as possible.
- Use headphones with a cord diameter of less than 3/32 inch (2.5 mm) so that the cord can be tied round the ferrite core.

124

## Identifying the parts and controls

### Remote Commander

The buttons that have the same name on the Remote Commander as on your camcorder function identically to the buttons on your camcorder.

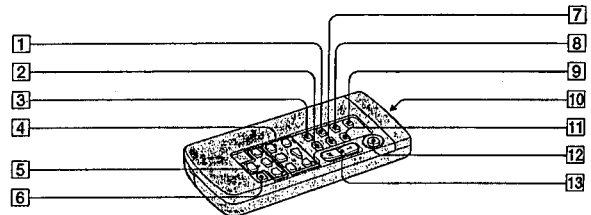

- |  |   |
|--|---|
| 1 ERASE button (p. 29, 33)   | 8 DISPLAY button (p. 34)  |
| 2 INDEX CHANGE button (p. 63)  | 9 AUDIO REC button (p. 36)  |
| 3 MENU button (p. 21)  | 10 Transmitter<br>Point toward the remote sensor to control your camcorder after turning on your camcorder. |
| 4 Video/audio control buttons (p. 32, 99)  | 11 PHOTO button (p. 22, 36)   |
| 5 +/- buttons (p. 21)<br>You can select tracks on the index display, items on the menu and play frame-by-frame, just like the control dial of the camcorder. | 12 START/STOP button (p. 22)<br>You cannot do the "ANTI GROUND" recording with this button.                 |
| 6 ENTER button (p. 21)<br>Press to confirm the selection in the menu.  | 13 Power zoom button (p. 27)  |
| 7 MARK button (p. 60)  |   |

Quick Reference

### To prepare the Remote Commander

Insert two size AA (R6) batteries by matching the + and - polarities on the batteries to the + - marks inside the battery compartment.

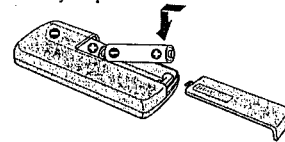

### Note on the Remote Commander

Point the remote sensor away from strong light sources such as direct sunlight or overhead lighting. Otherwise, the Remote Commander may not function properly.

125

## Identifying the parts and controls

### Operation indicators

#### CAMERA/INTERVIEW mode

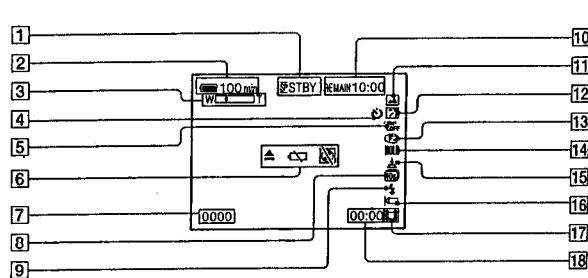

- |  |  |
|--|--|
| 1 Standby/Recording Indicator (p. 22)/<br>Recording mode indicator (p. 26) | 11 PROGRAM AE indicator (p. 41)            |
| 2 Remaining battery time indicator (p. 14)                                 | 12 Backlight indicator (p. 40)             |
| 3 Zoom indicator (p. 27)   | 13 Manual focus/Infinity indicator (p. 43) |
| 4 Self-timer indicator (p. 38)   | 14 White balance mode indicator (p. 46)    |
| 5 SteadyShot OFF Indicator (p. 45)   | 15 Anti ground recording indicator (p. 93) |
| 6 Warning indicators (p. 116)  | 16 Anti wind noise indicator (p. 92)       |
| 7 Track number   | 17 Track type icon (p. 31)                 |
| 8 10-second track mode indicator (p. 93)                                   | 18 Recording time                          |
| 9 Flash mode indicator (p. 23)   |  |
| 10 Remaining disc indicator (p. 58)  |  |

126

## Identifying the parts and controls

### PLAY/EDIT mode

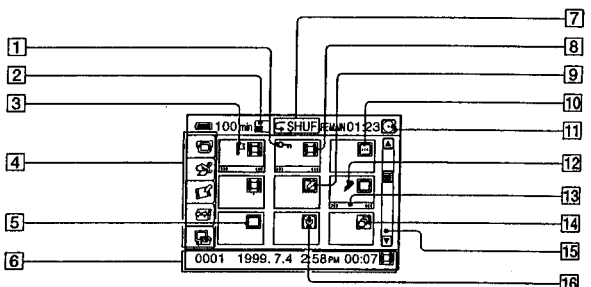

- |   |   |
|---|---|
| 1 Protect icon (p. 61)  | 9 Memo icon (p. 78)                                 |
| 2 Picture-in-picture indicator (p. 47)  | 10 Title icon (p. 82)                               |
| 3 Mark icon (p. 60)   | 11 Disc indicator (p. 58)                           |
| 4 Menu icons (p. 91)  | 12 Drawing icon (p. 78)                             |
| 5 Photo icon (p. 31)  | 13 Scene transition/picture effect icon (p. 83, 86) |
| 6 Track data (p. 59)<br>Track number, recorded date, track name, recording time, track type | 14 Group icon (p. 74)                               |
| 7 Play mode indicator (p. 51, 53, 54)   | 15 Scroll bar (p. 31)                               |
| 8 Movie icon (p. 31)  | 16 Audio icon (p. 36)                               |

Quick Reference

127

Identifying the parts and controls

AC adaptor/charger

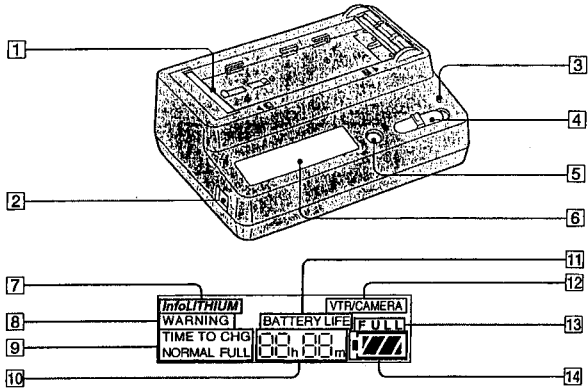

- 1 Terminal shutter (p. 10)
- 2 DC OUT connector (p. 15)
- 3 CHARGE lamp (p. 10)
- 4 Mode change switch (p. 10, 15)
- 5 DISPLAY CHANGE button (p. 12)
- 6 Display window
- 7 "InfoLITHIUM" indicator
- 8 WARNING indicator
- 9 TIME TO CHG (charge) indicator (p. 13)
- 10 Time indicator (p. 13)
- 11 BATTERY LIFE (battery remaining time) indicator (p. 12)
- 12 VTR/CAMERA indicator
- 13 Full charge indicator (p. 11)
- 14 Remaining battery indicator (p. 10)

Identifying the parts and controls

Connecting cord

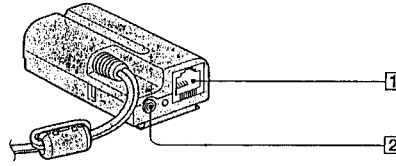

- 1 10BASE-T connecting jack (p. 102)
- 2 LINE IN jack (p. 23)

Quick Reference

## SECTION 2 DISASSEMBLY

- This set can be disassembled in the order shown below.

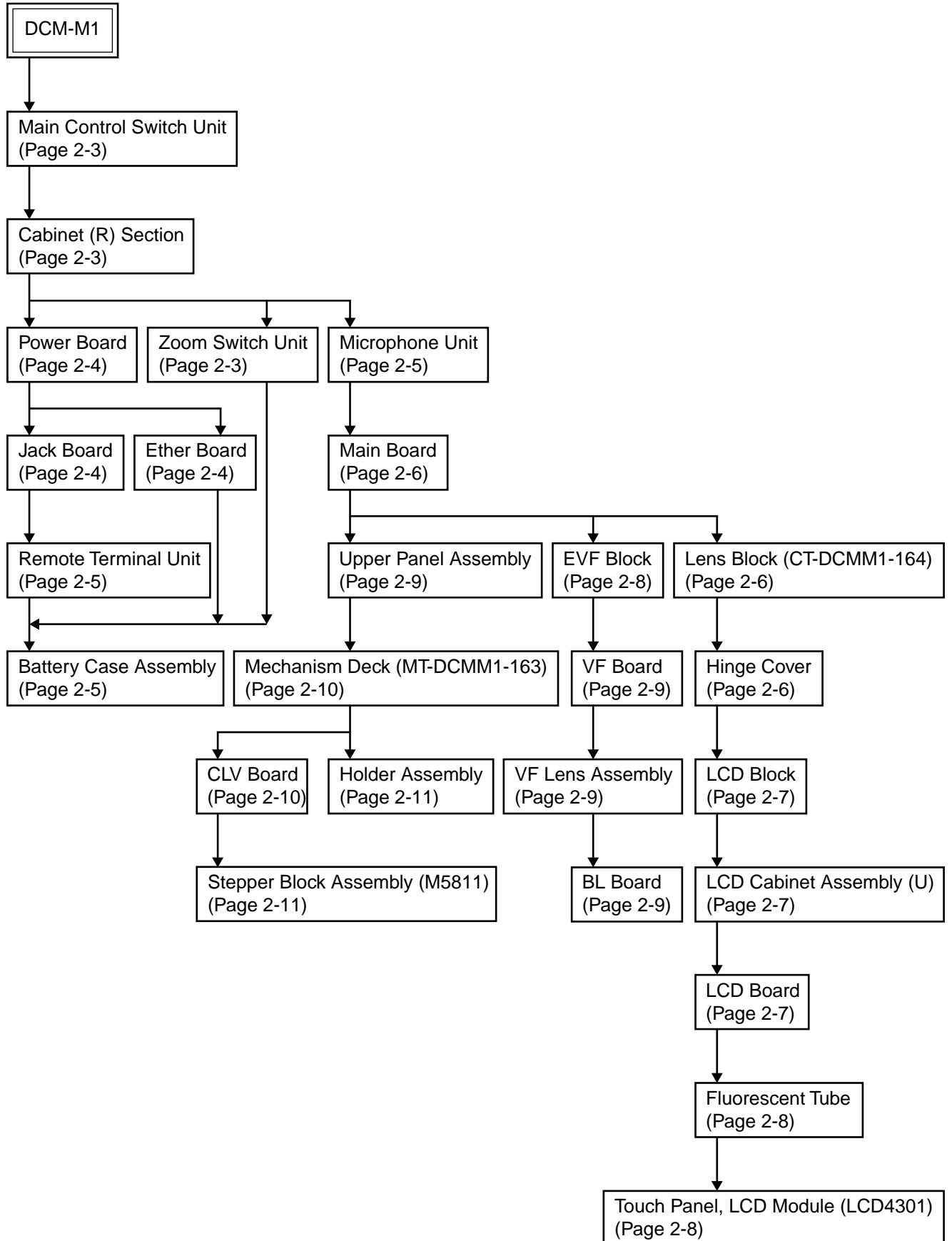

## PAPER BOX FOR SCREW

We suggest to make a photo copy of this page before removing the set,  
put cellophane tape (adhesive tape) in each dotted-line frame for each screw.  
You can replace these screws without any mistakes after this preparation.  
(If you use OHP sheet or something similar, you can use it repeatedly.)

unit: mm

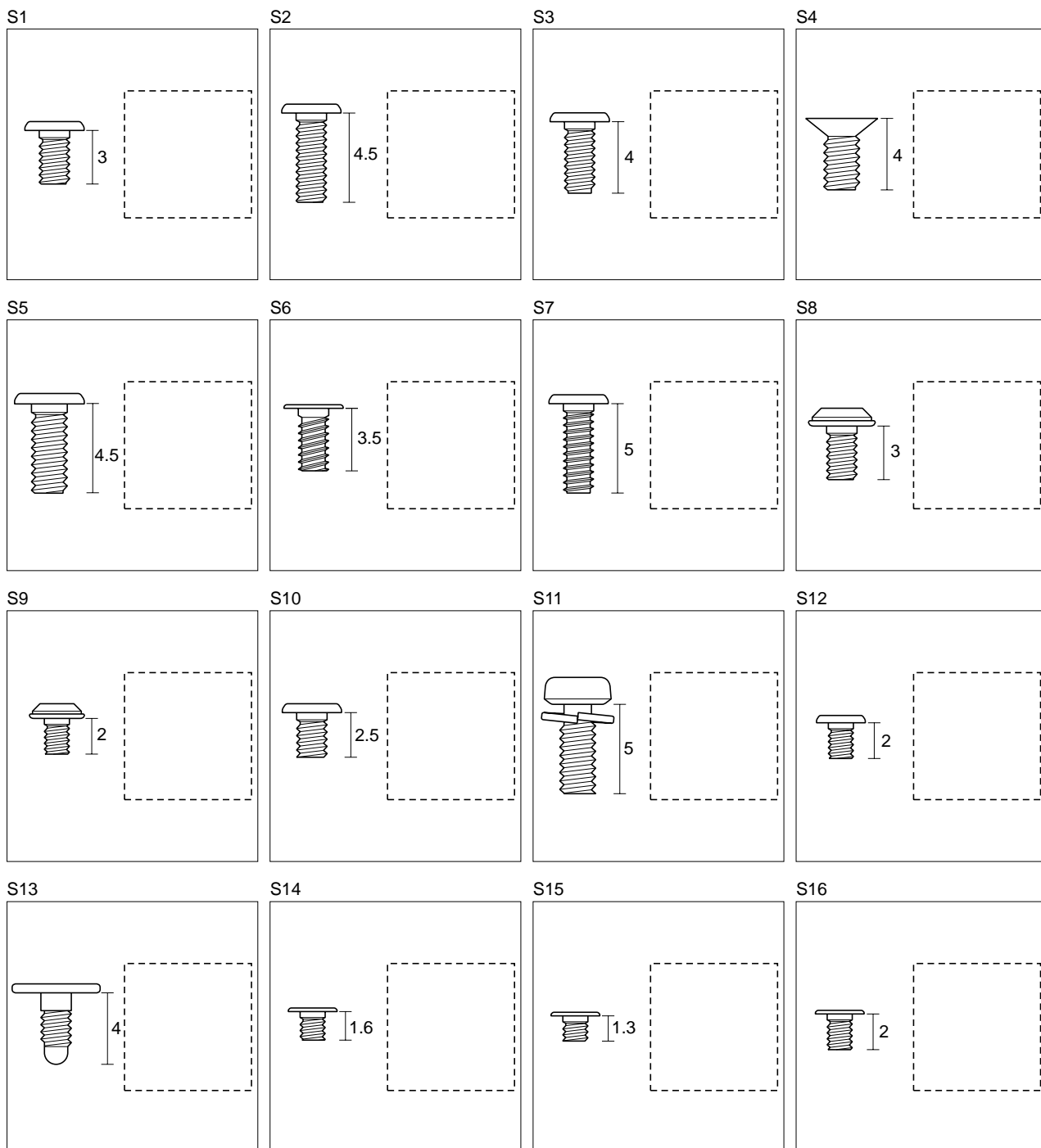

**Note:** Follow the disassembly procedure in the numerical order given.

### 2-1. MAIN CONTROL SWITCH UNIT

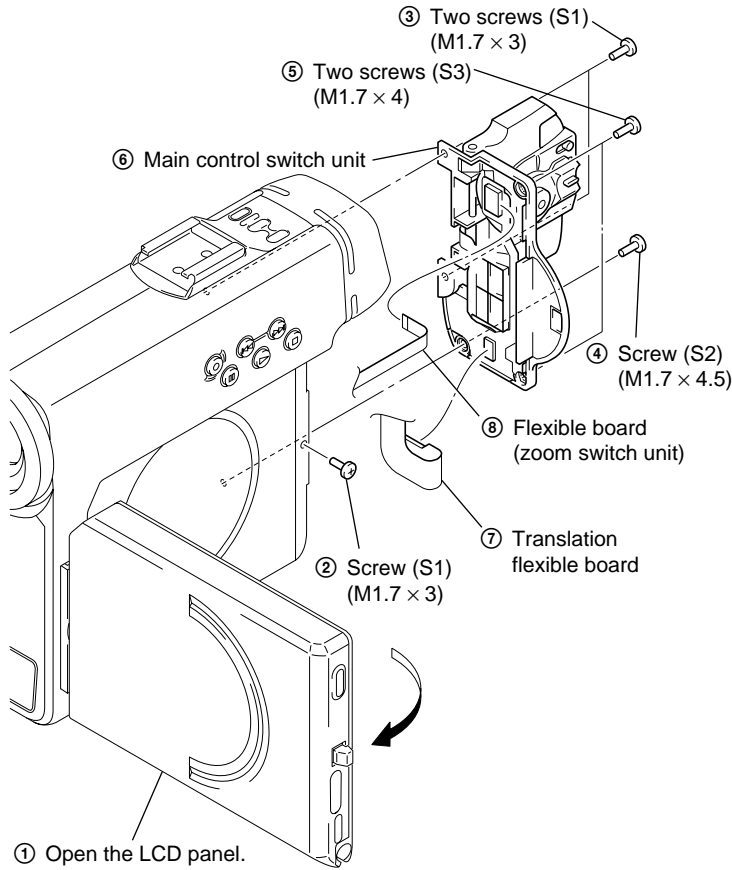

### 2-3. ZOOM SWITCH UNIT

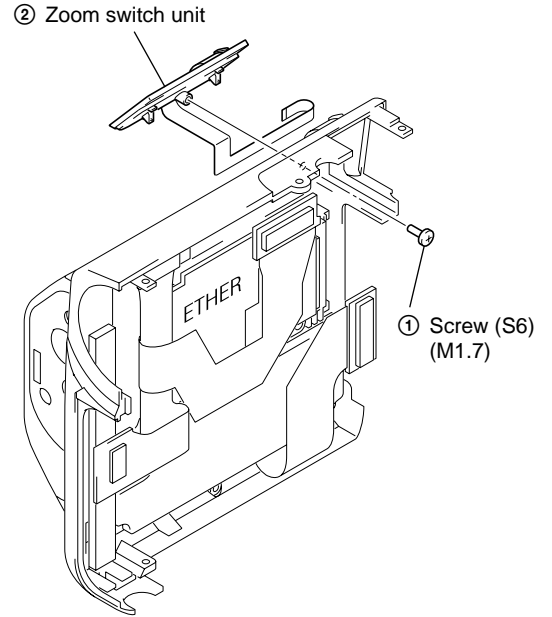

### 2-2. CABINET (R) SECTION

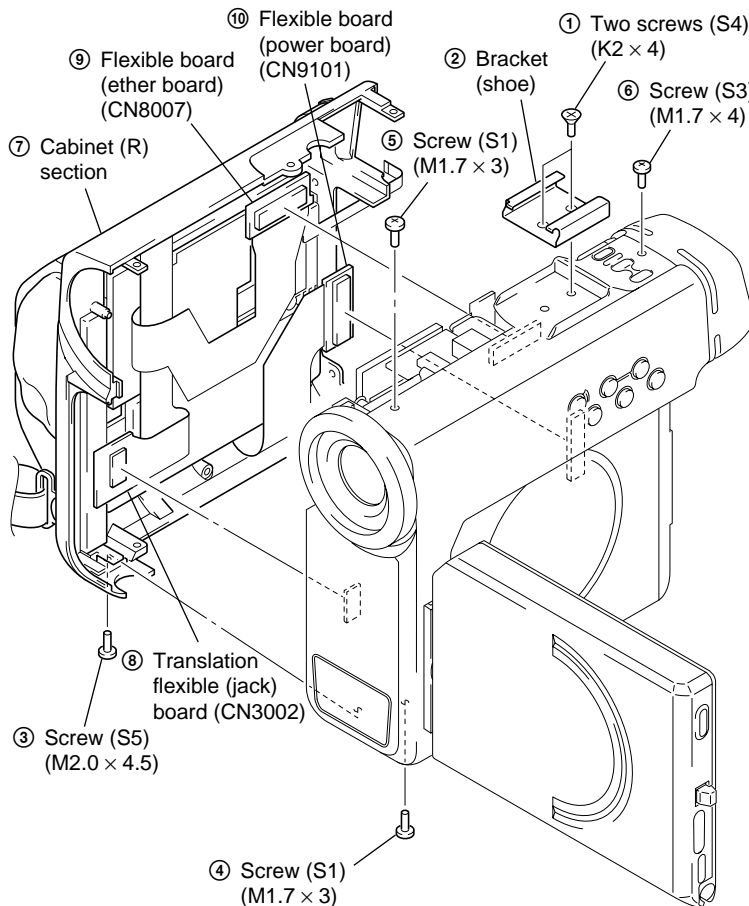

S1

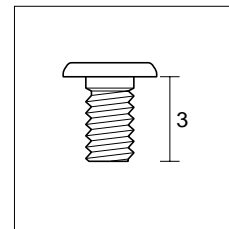

S4

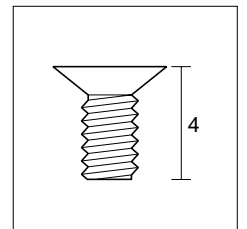

S2

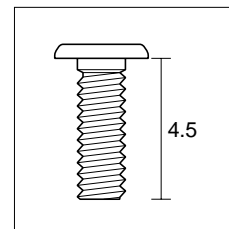

S5

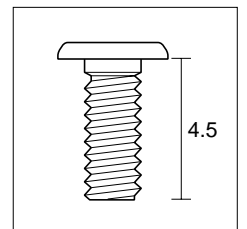

S3

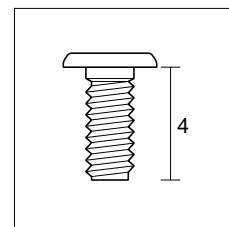

S6

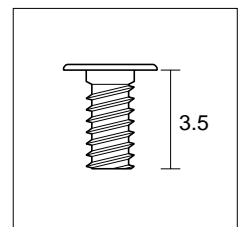

## 2-4. POWER BOARD

## 2-6. JACK BOARD

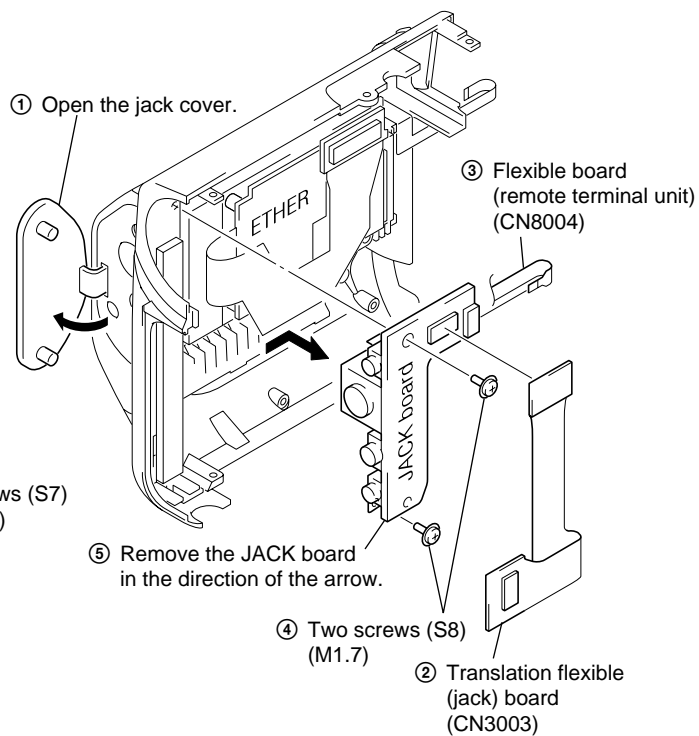
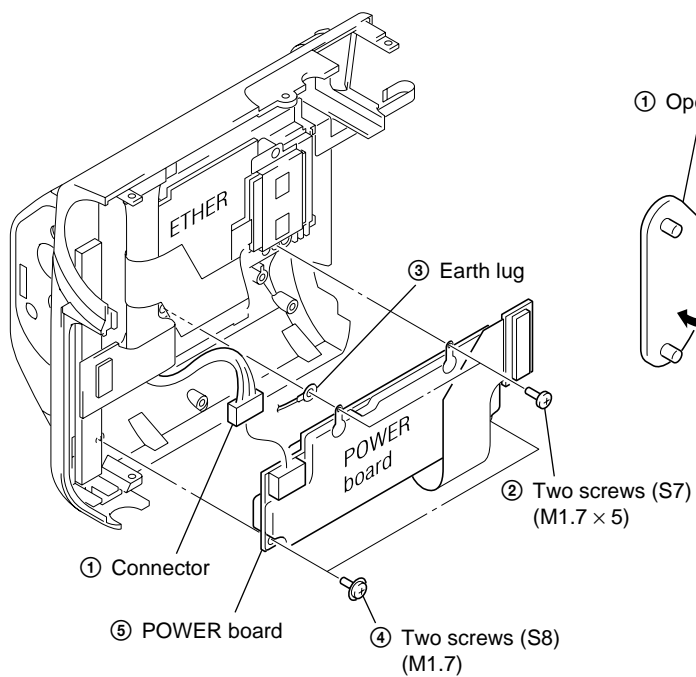

## 2-5. ETHER BOARD

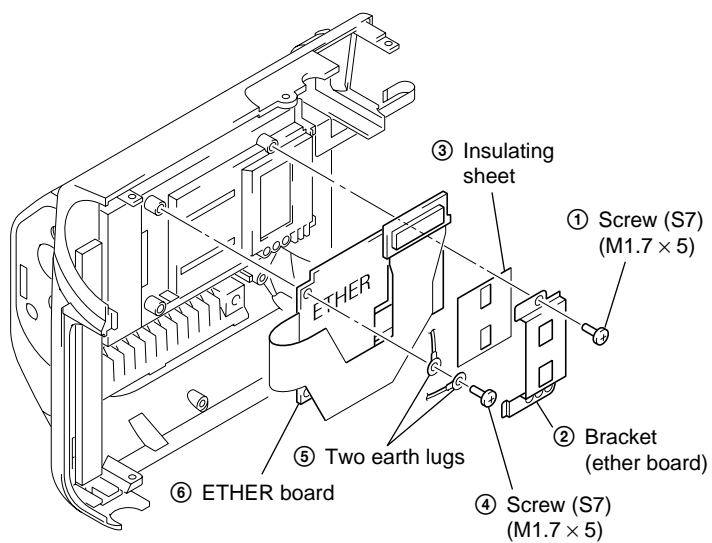

S7

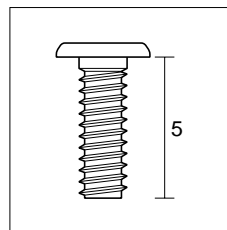

S8

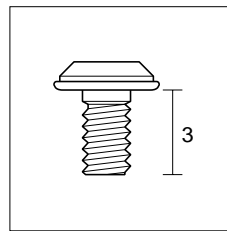

## 2-7. REMOTE TERMINAL UNIT

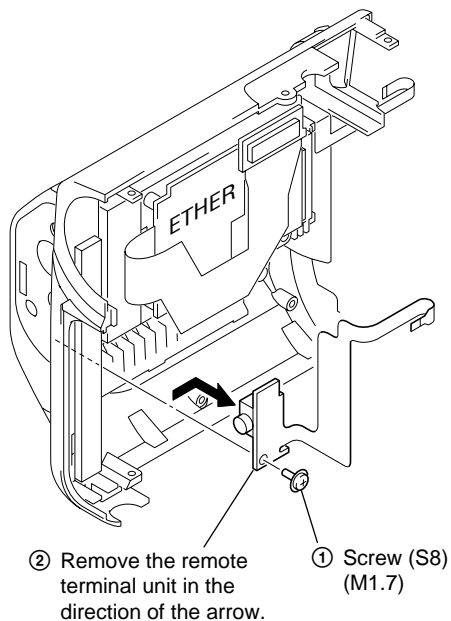

## 2-9. MICROPHONE BLOCK

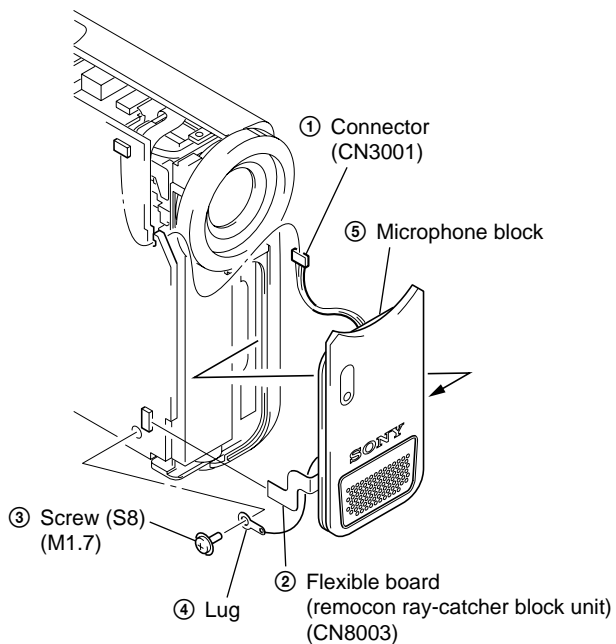

## 2-8. BATTERY CASE ASSEMBLY

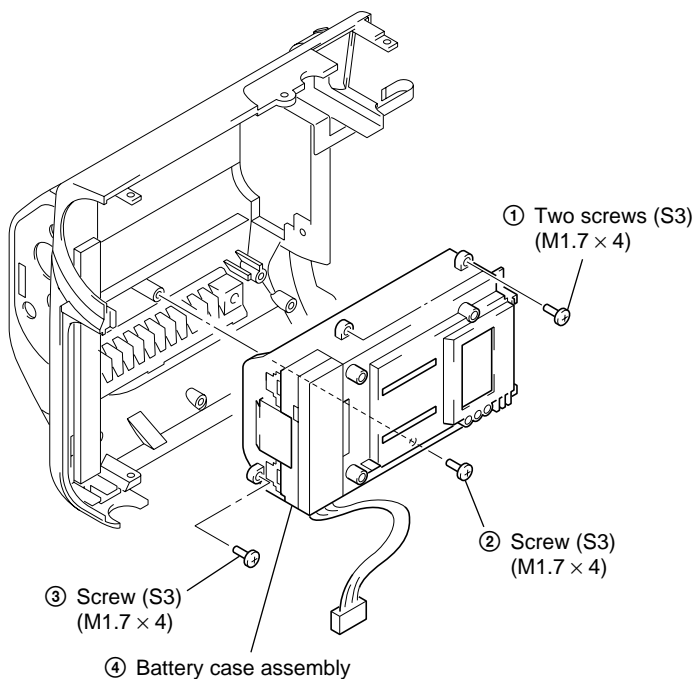

S3

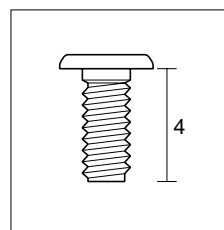

S8

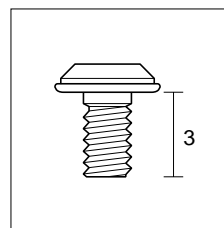

## 2-10. MAIN BOARD

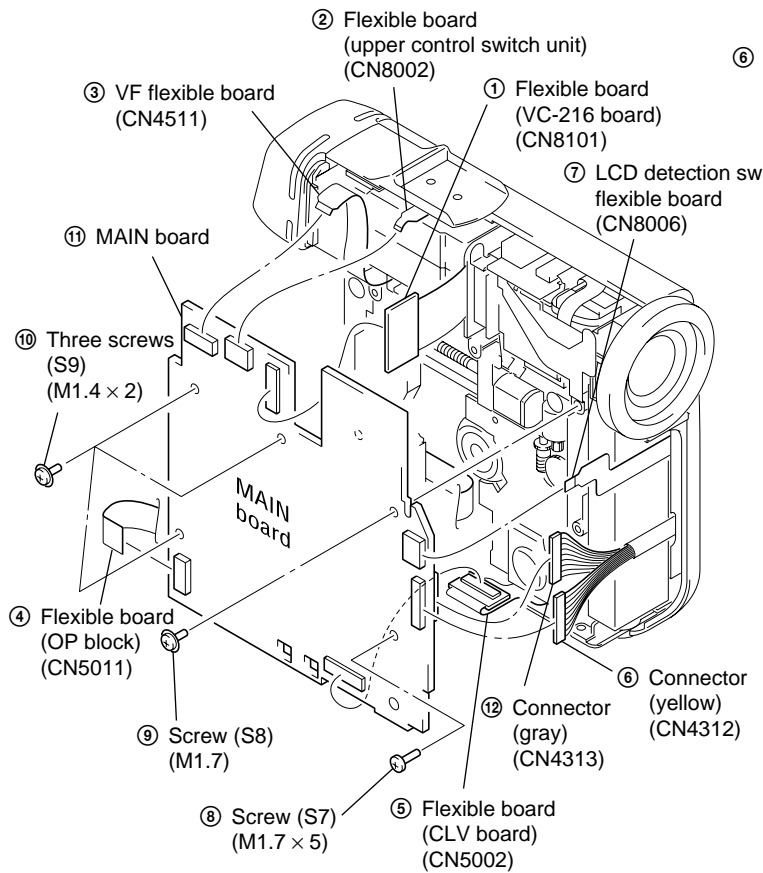

## 2-12. HINGE COVER

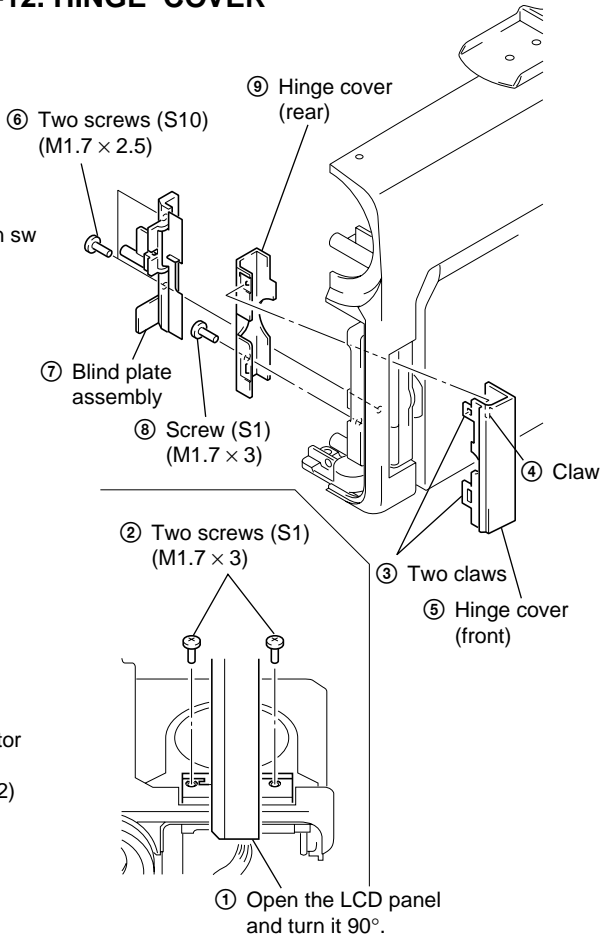

## 2-11. LENS BLOCK (CT-DCMM1-164)

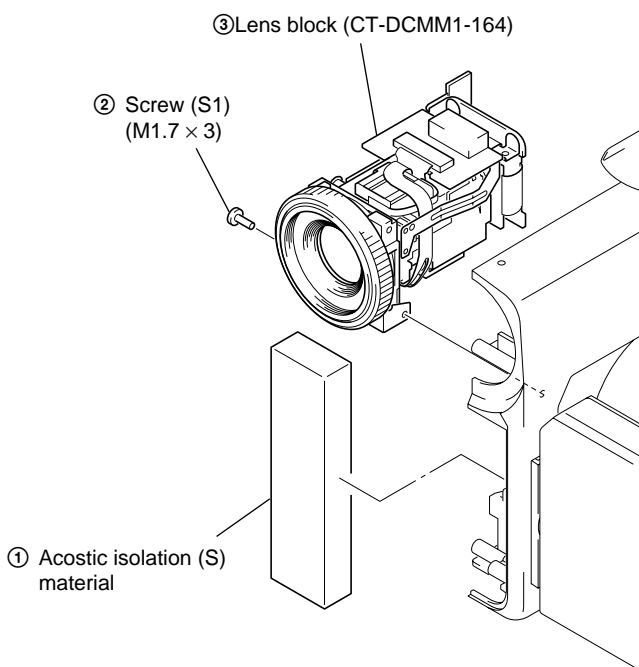

S1

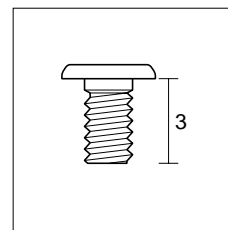

S9

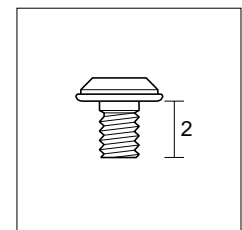

S7

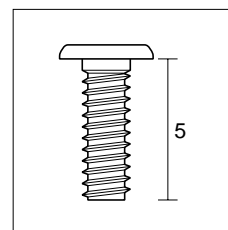

S10

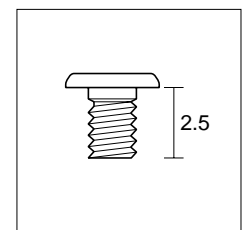

S8

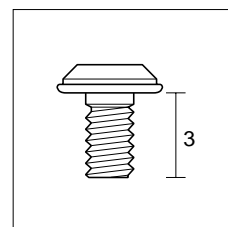



## 2-13. LCD BLOCK

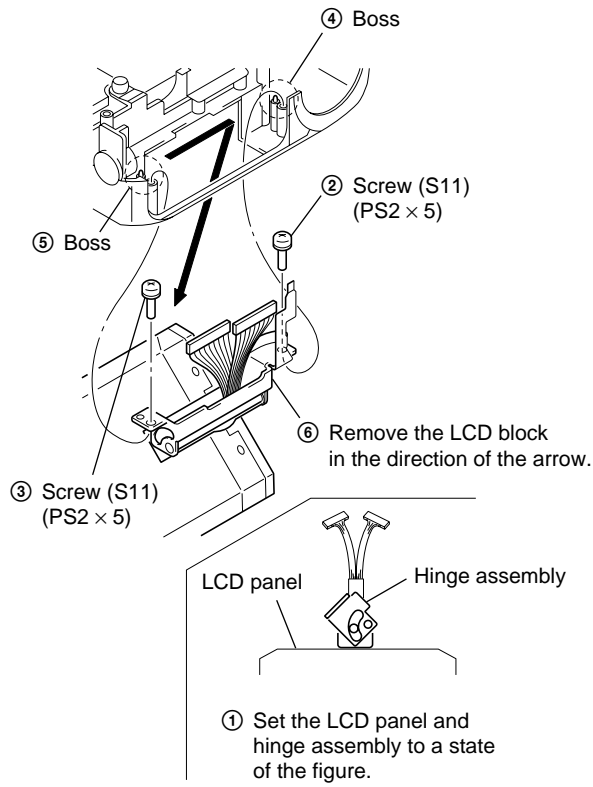

## 2-15. LCD BOARD

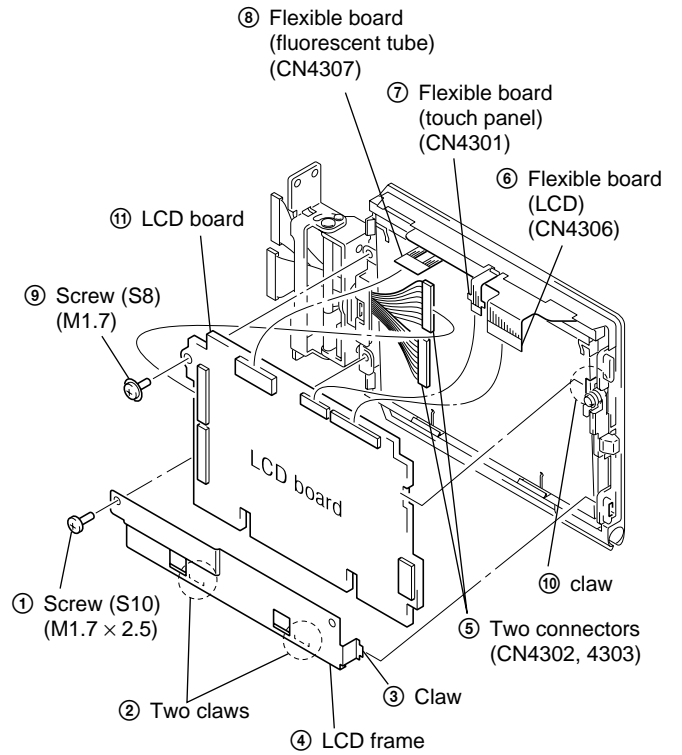

## 2-14. LCD CABINET ASSEMBLY (U)

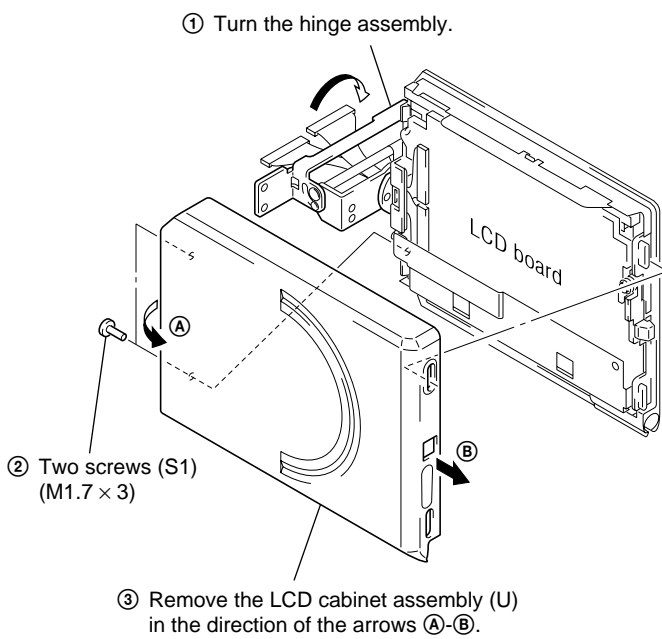

S1

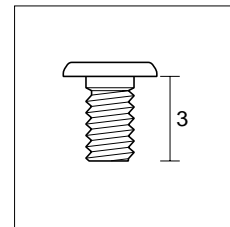

S11

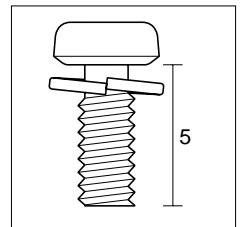

S8

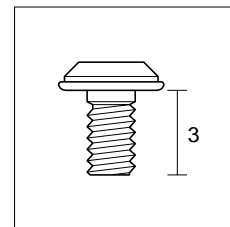

S10

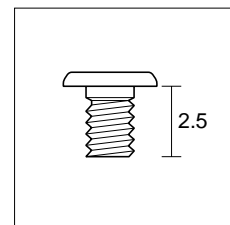

## 2-16. FLUORESCENT TUBE

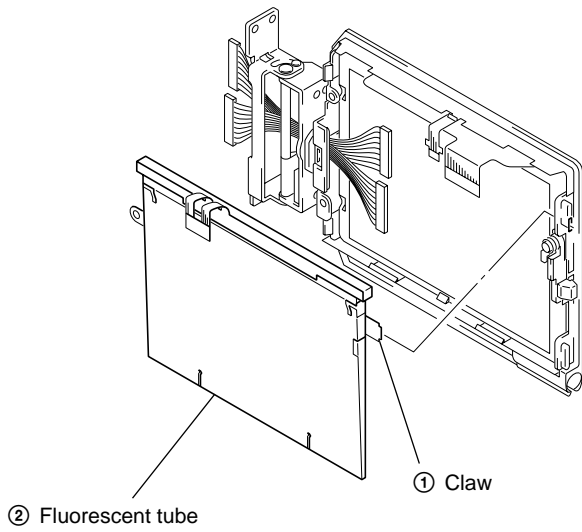

## 2-18. EVF BLOCK

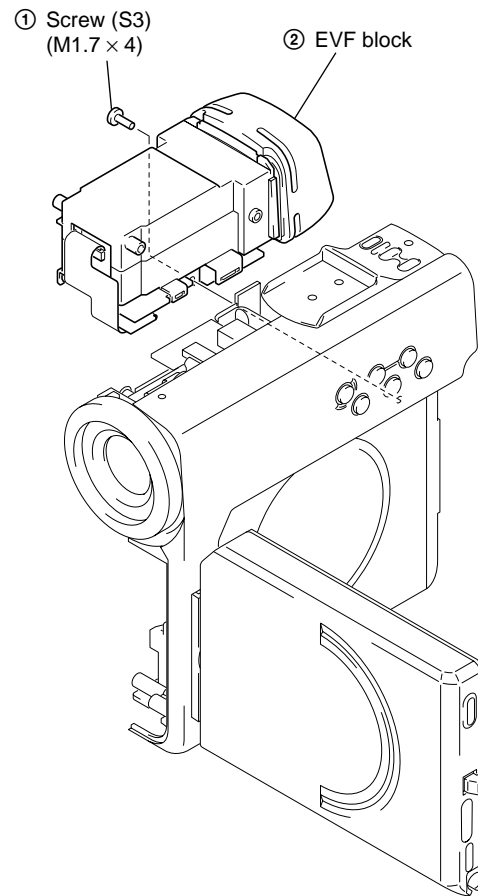

## 2-17. TOUCH PANEL, LCD MODULE (LCD4301)

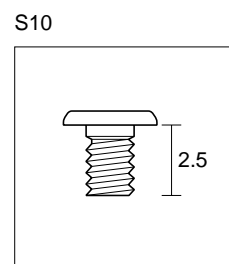
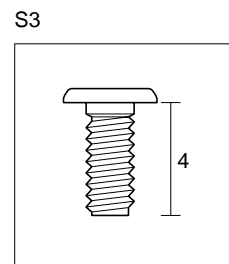
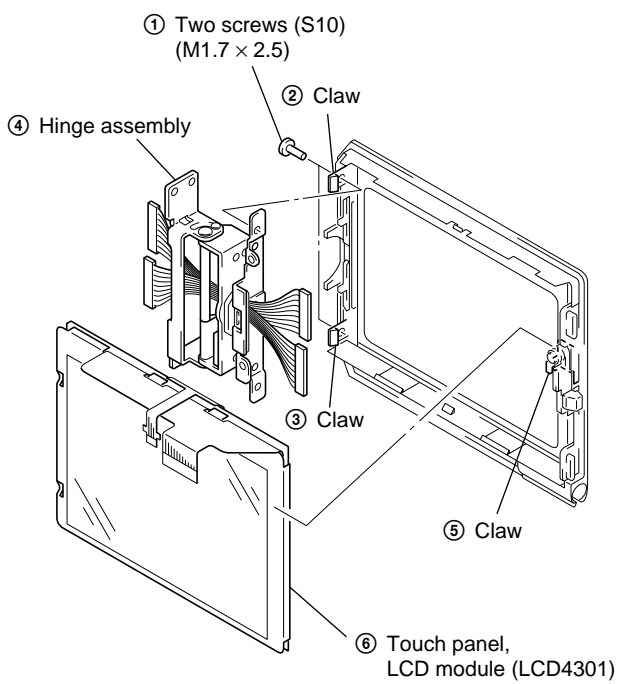

## 2-19. VF BOARD

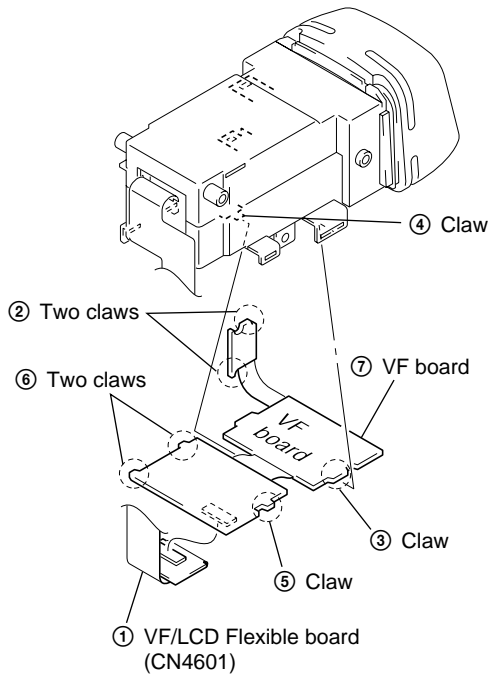

## 2-21. BL BOARD

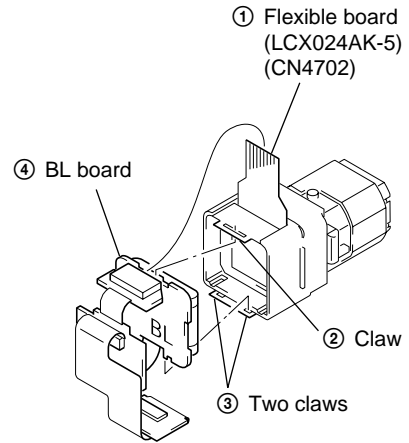

## 2-20. VF LENS ASSEMBLY

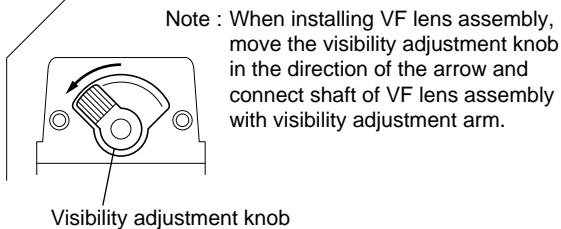
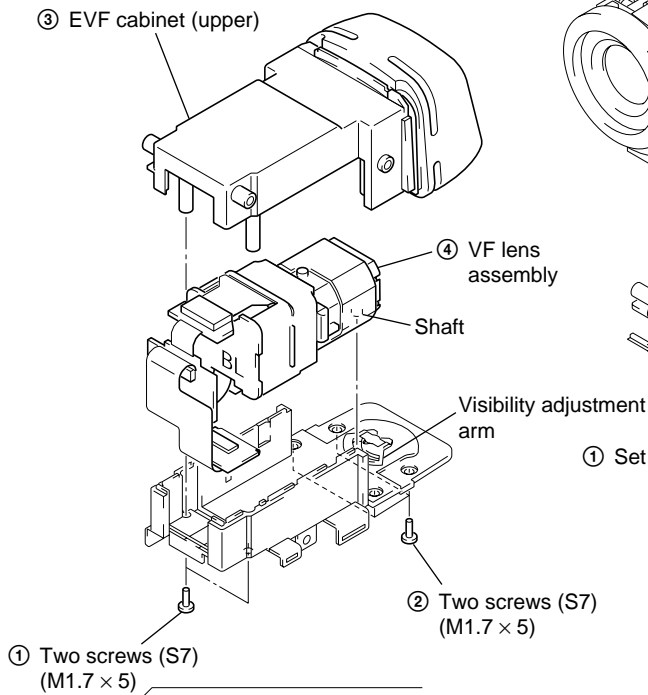

## 2-22. UPPER PANEL ASSEMBLY

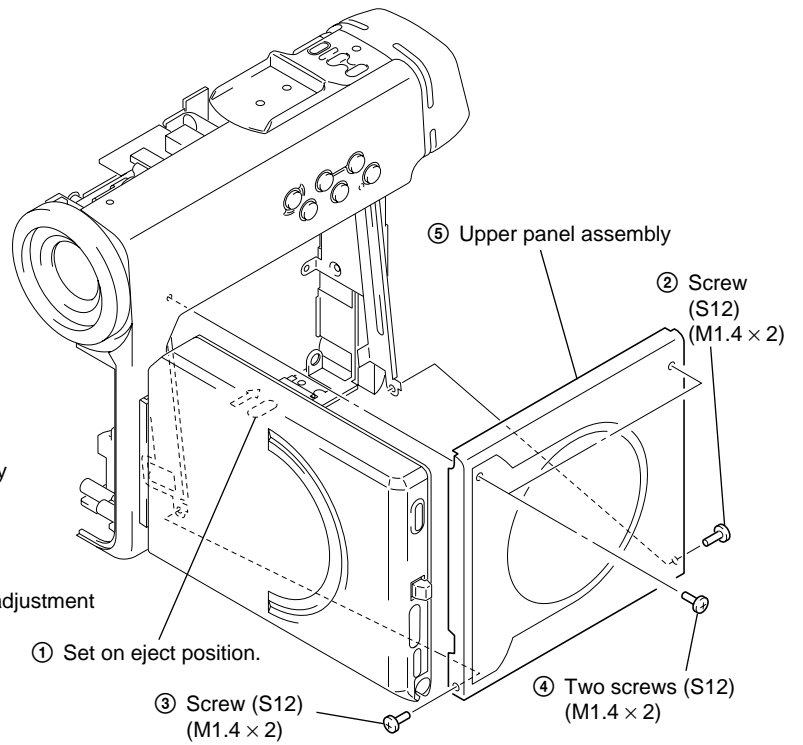

S7

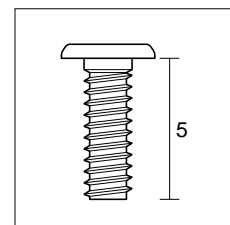

S12

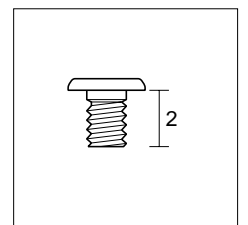

## 2-23. MECHANISM DECK (MT-DCMM1-163)

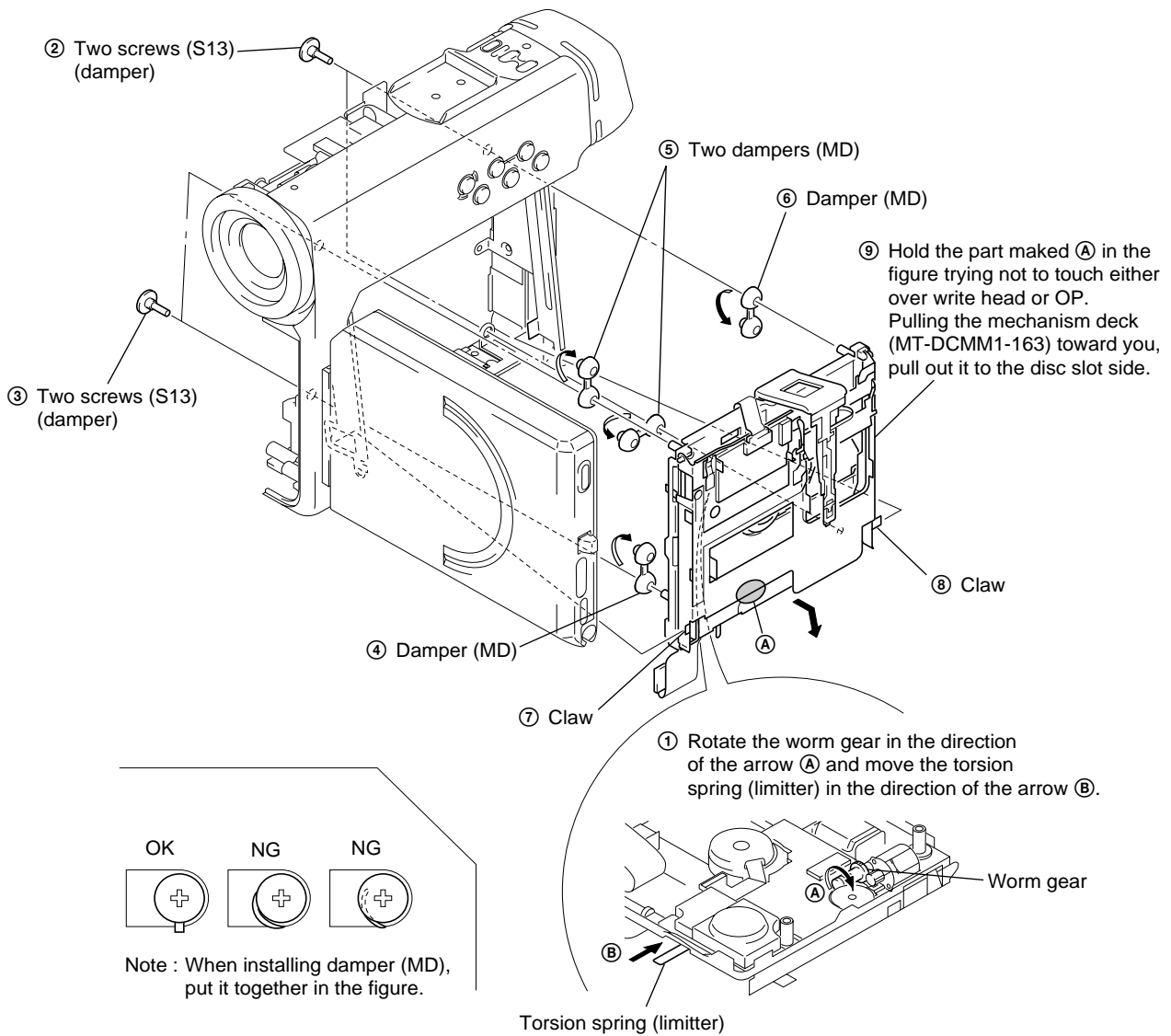

## 2-24. CLV BOARD

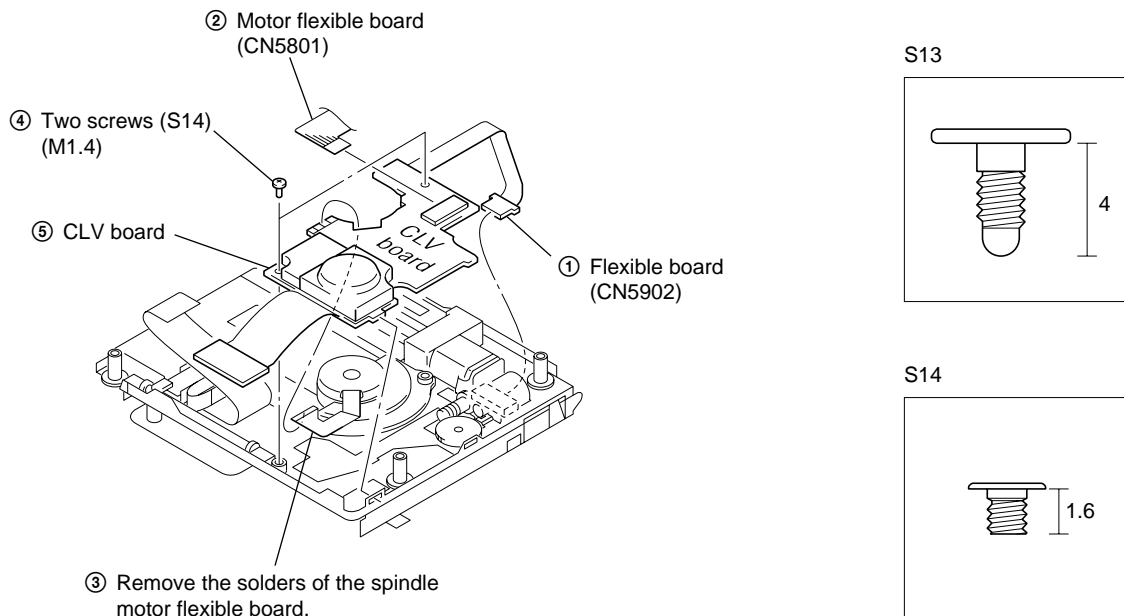

**2-25. STEPPER BLOCK ASSEMBLY (M5811)**

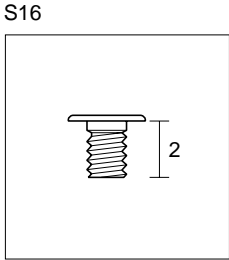
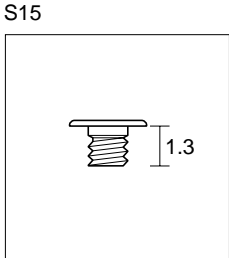
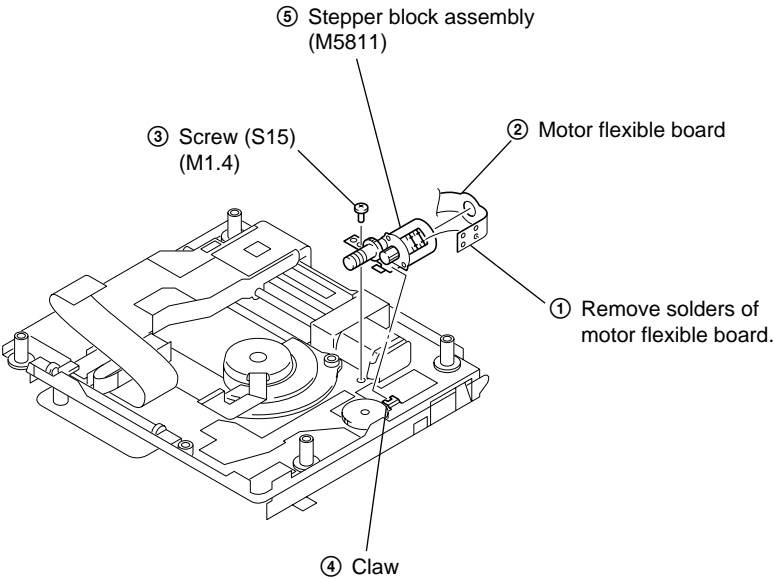

**2-26. HOLDER ASSEMBLY**

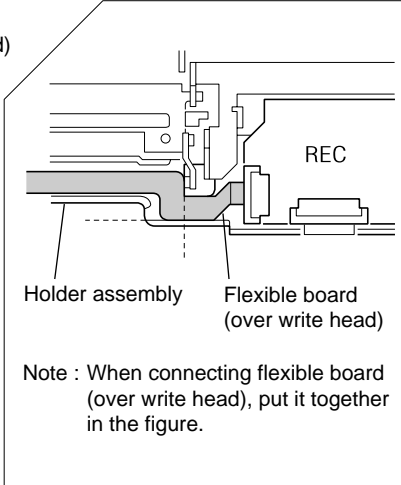
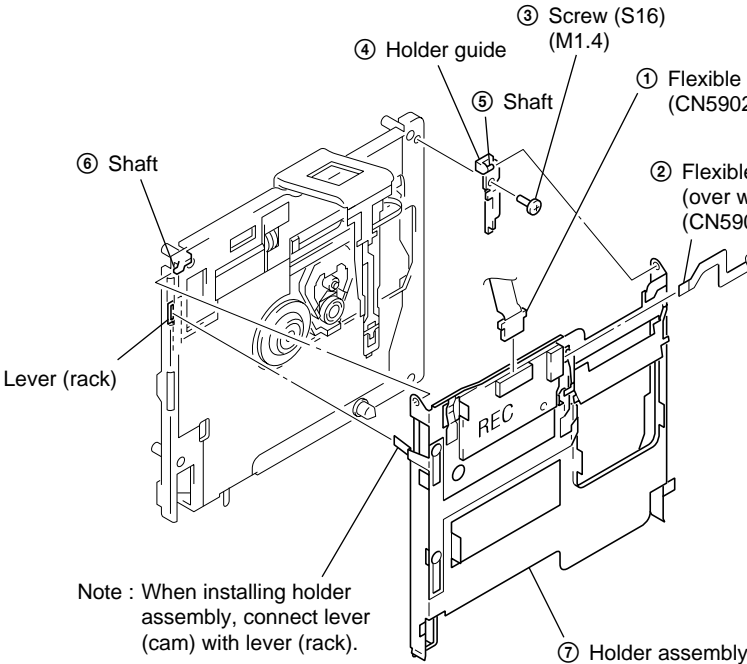

## 2-27. SERVICE POSITION

Preparation: Refer to previous section "DISASSEMBLY", and connect as shown in the figure after each part has been removed.

### MAIN BOARD, CLV BOARD

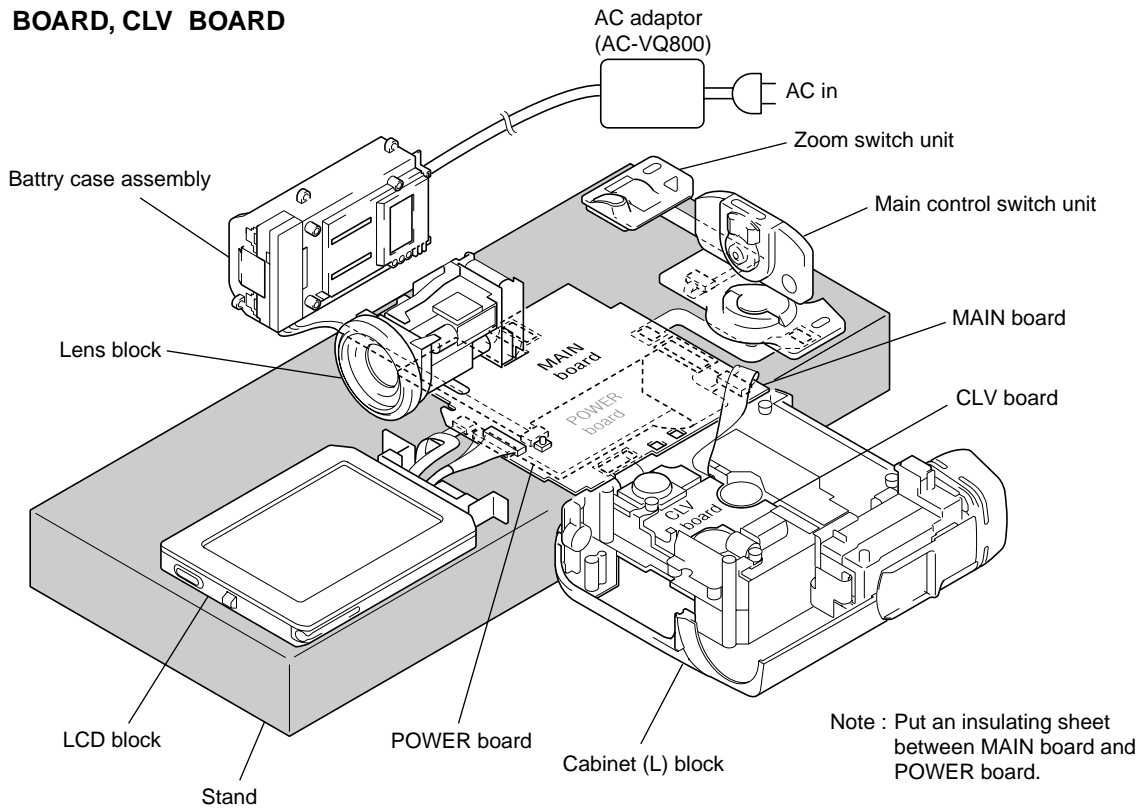

### LCD BOARD

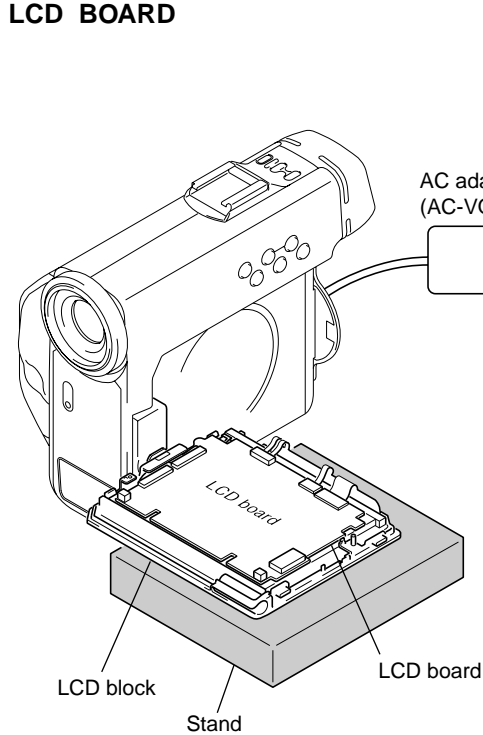

### VF BOARD

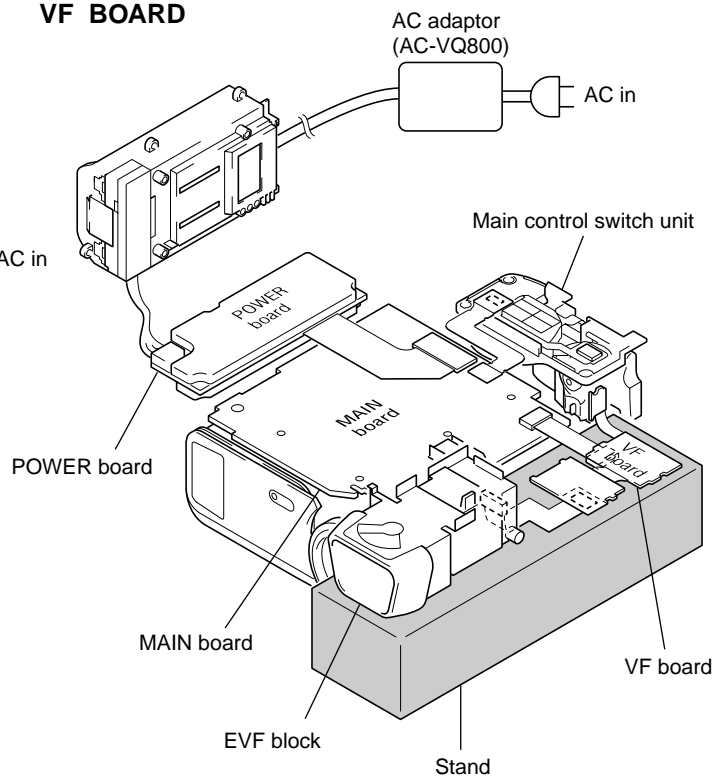

# MEMO

---

A series of horizontal dotted lines for writing.

## 2-28. CIRCUIT BOARDS LOCATION

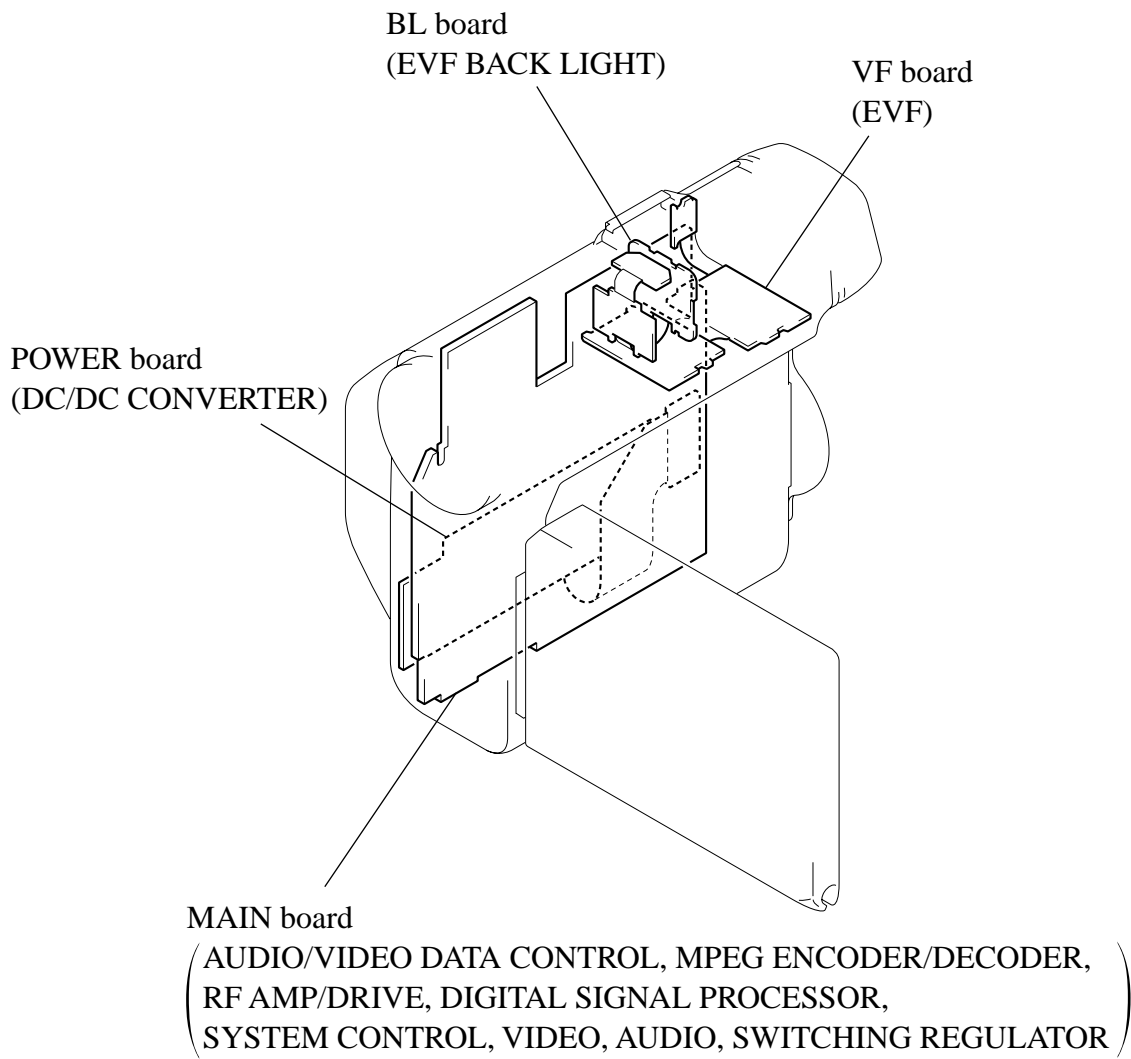



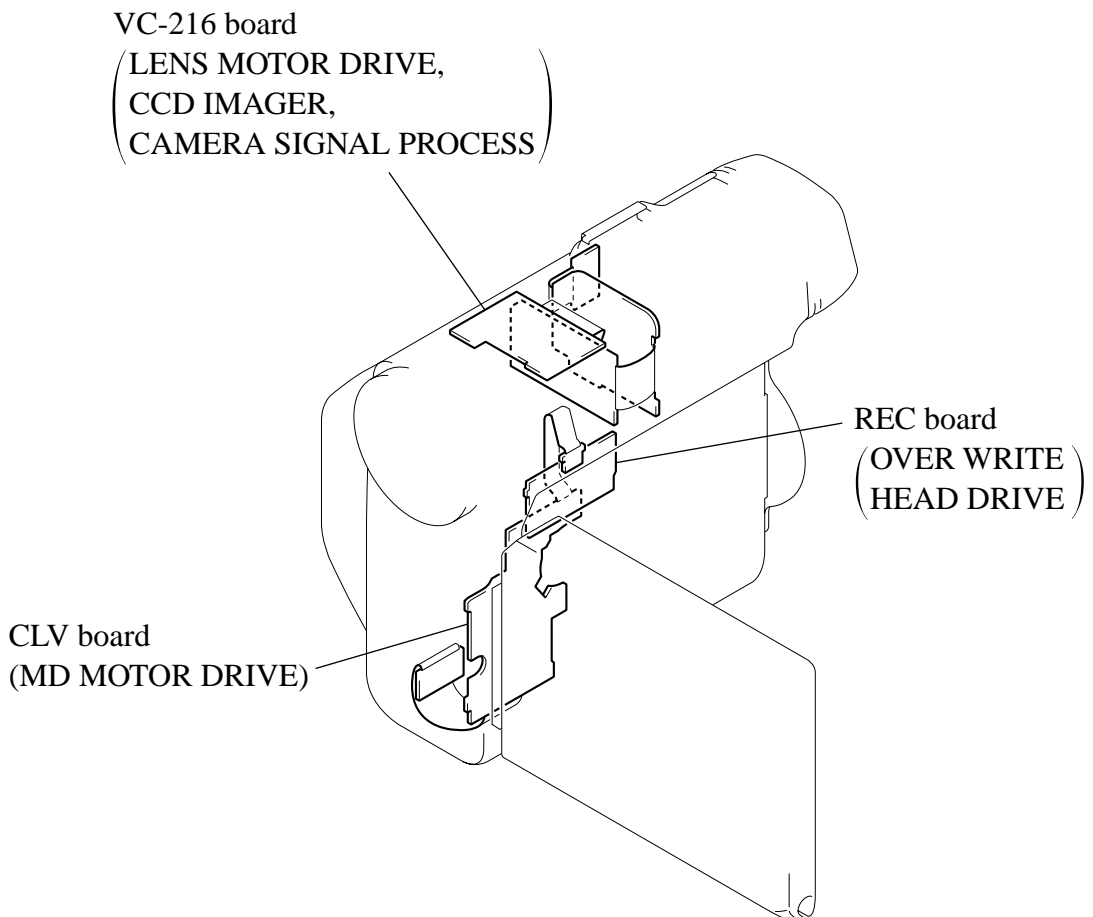
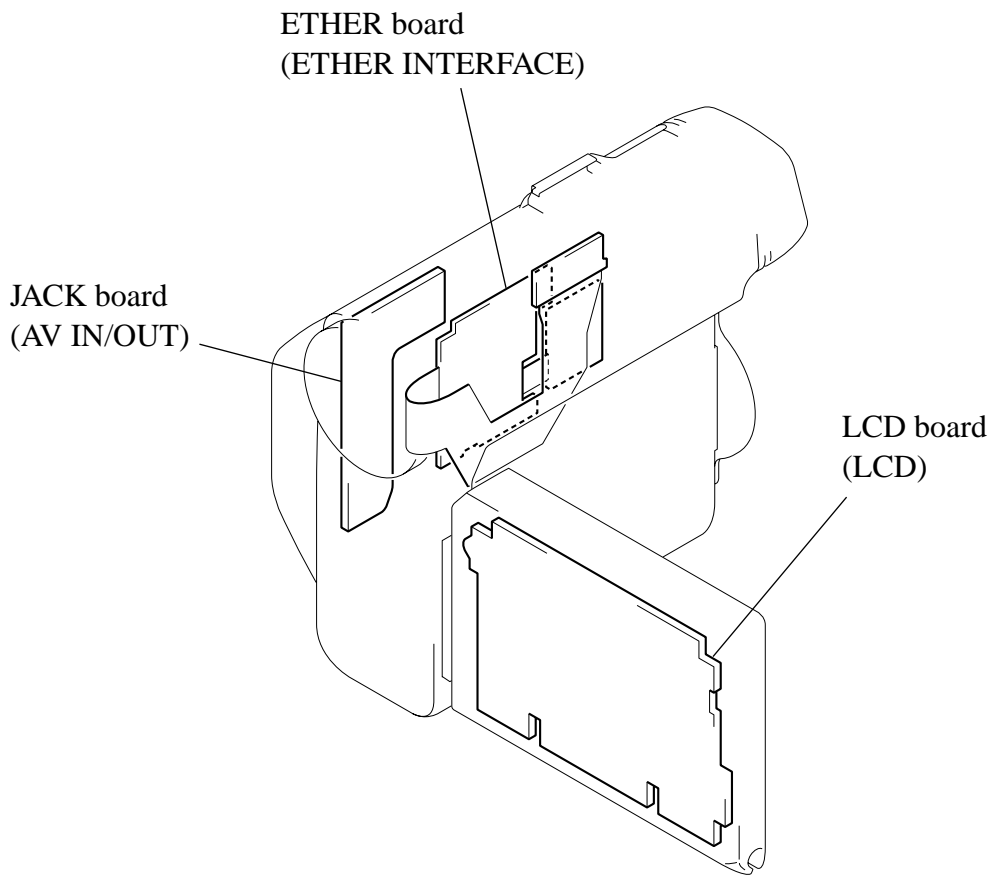

## 2-29. FLEXIBLE BOARDS LOCATION

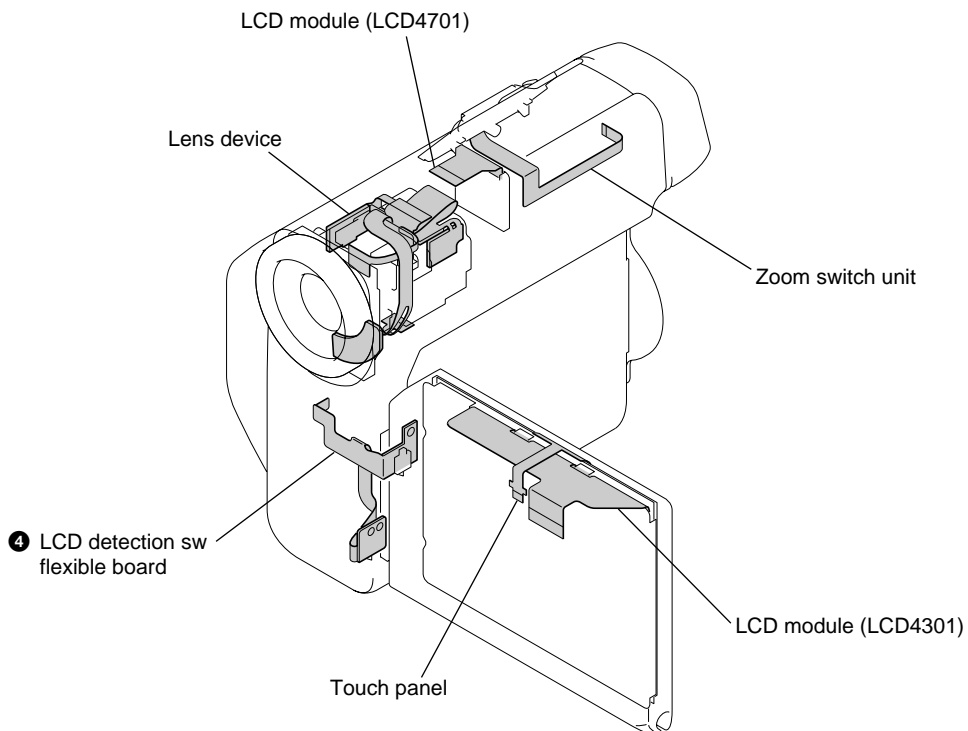
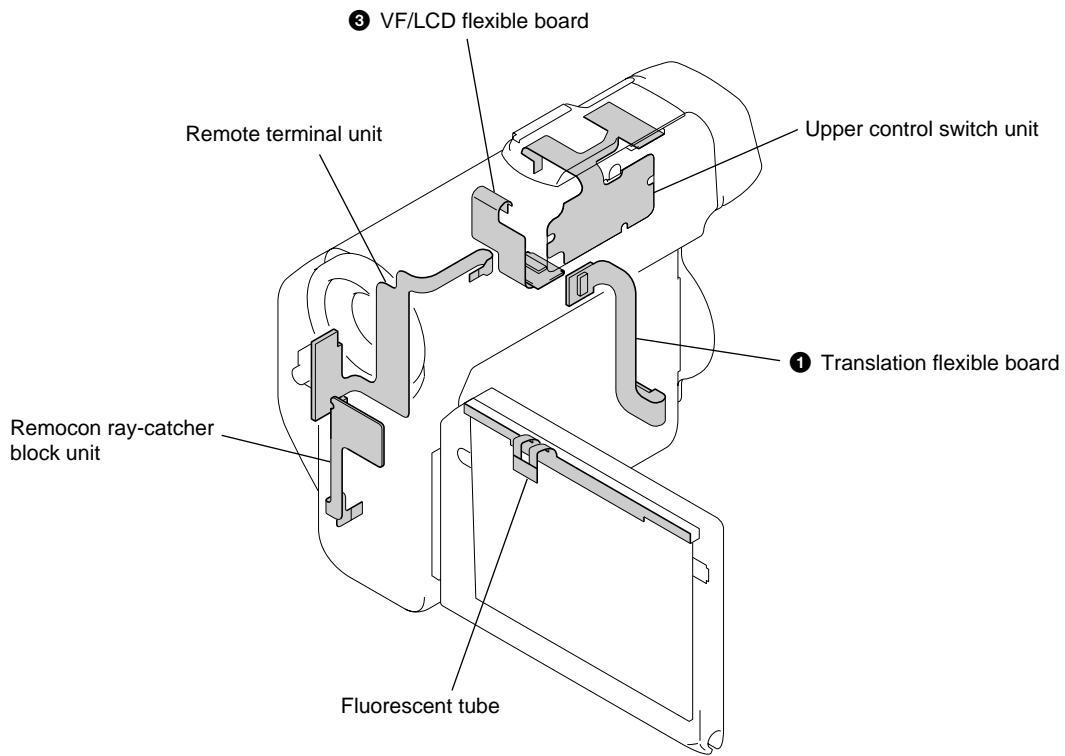

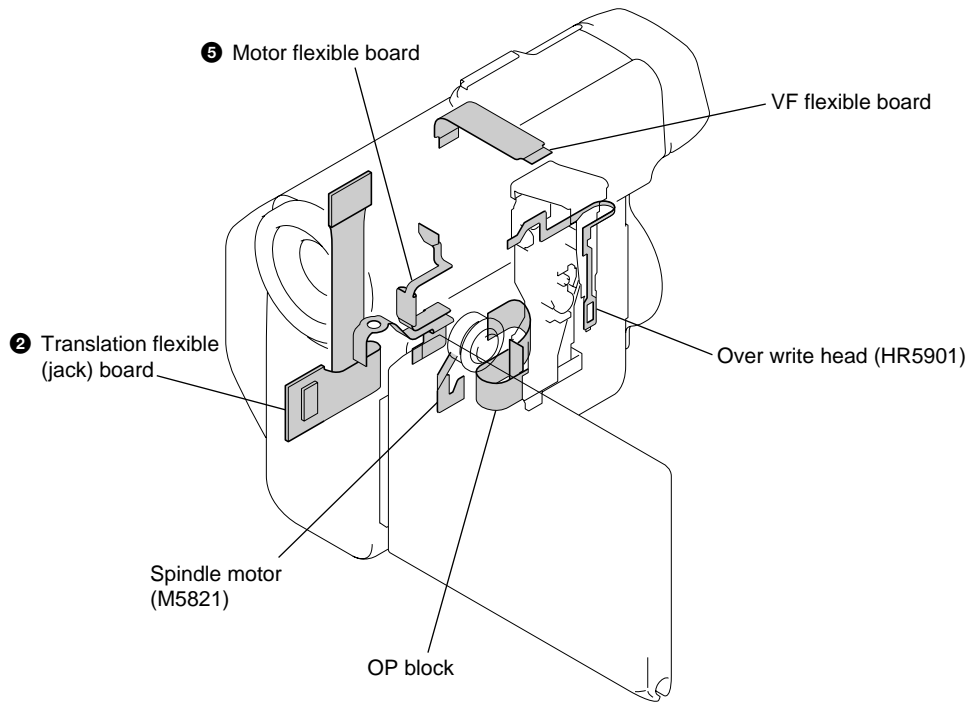

unit: mm

1 Translation flexible board

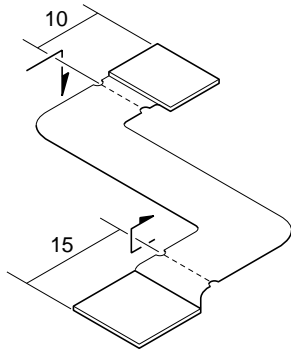

2 Translation flexible (jack) board

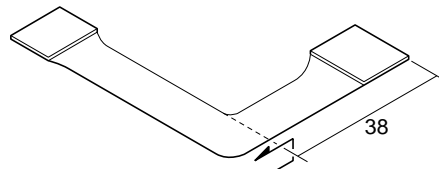

3 VF/LCD flexible board

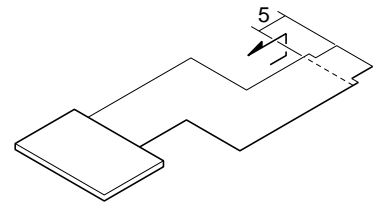

4 LCD detection sw flexible board

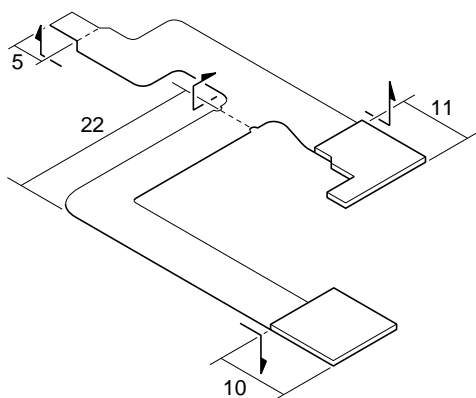

5 Motor flexible board

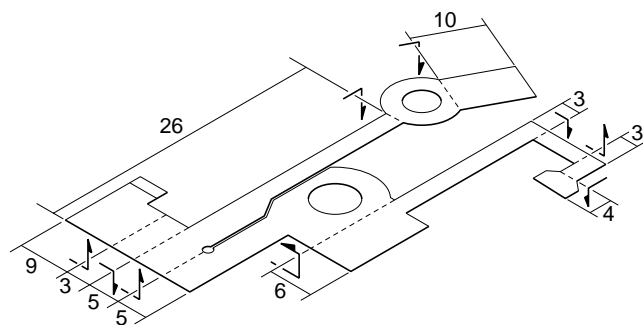

# SECTION 3 BLOCK DIAGRAMS

## 3-1. OVERALL BLOCK DIAGRAM

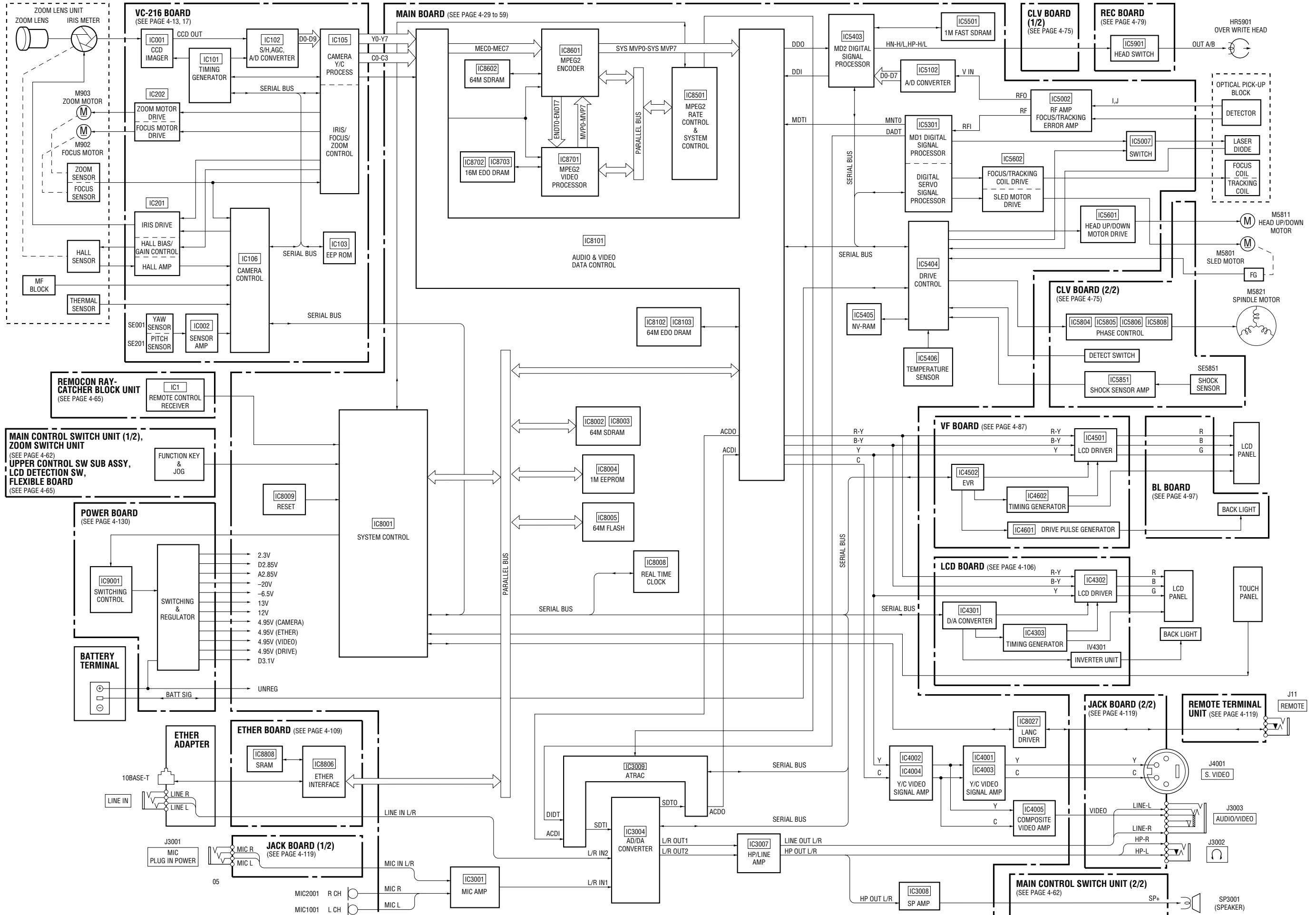

3-2. CAMERA SIGNAL PROCESS BLOCK DIAGRAM

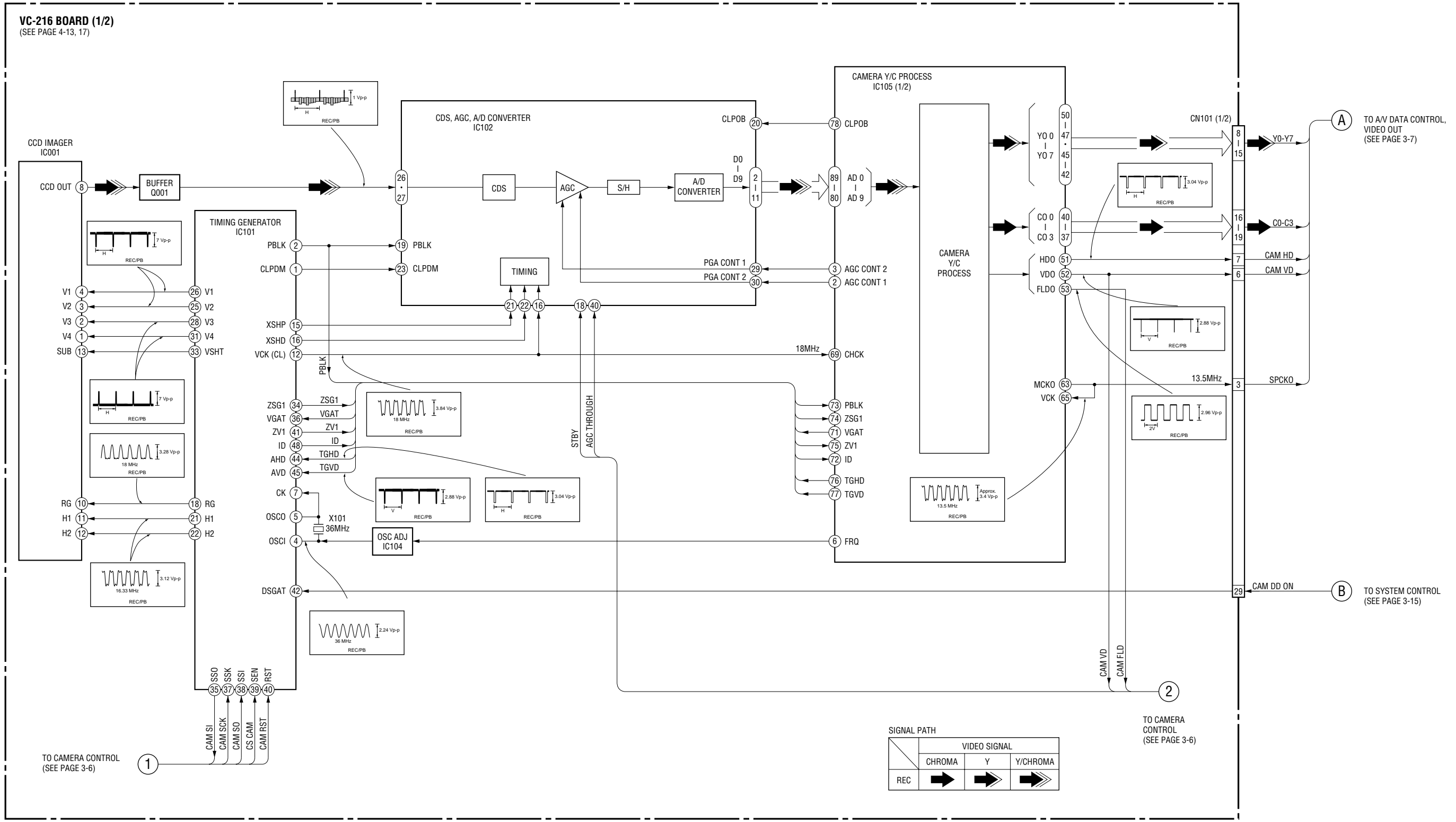

3-3. CAMERA CONTROL BLOCK DIAGRAM

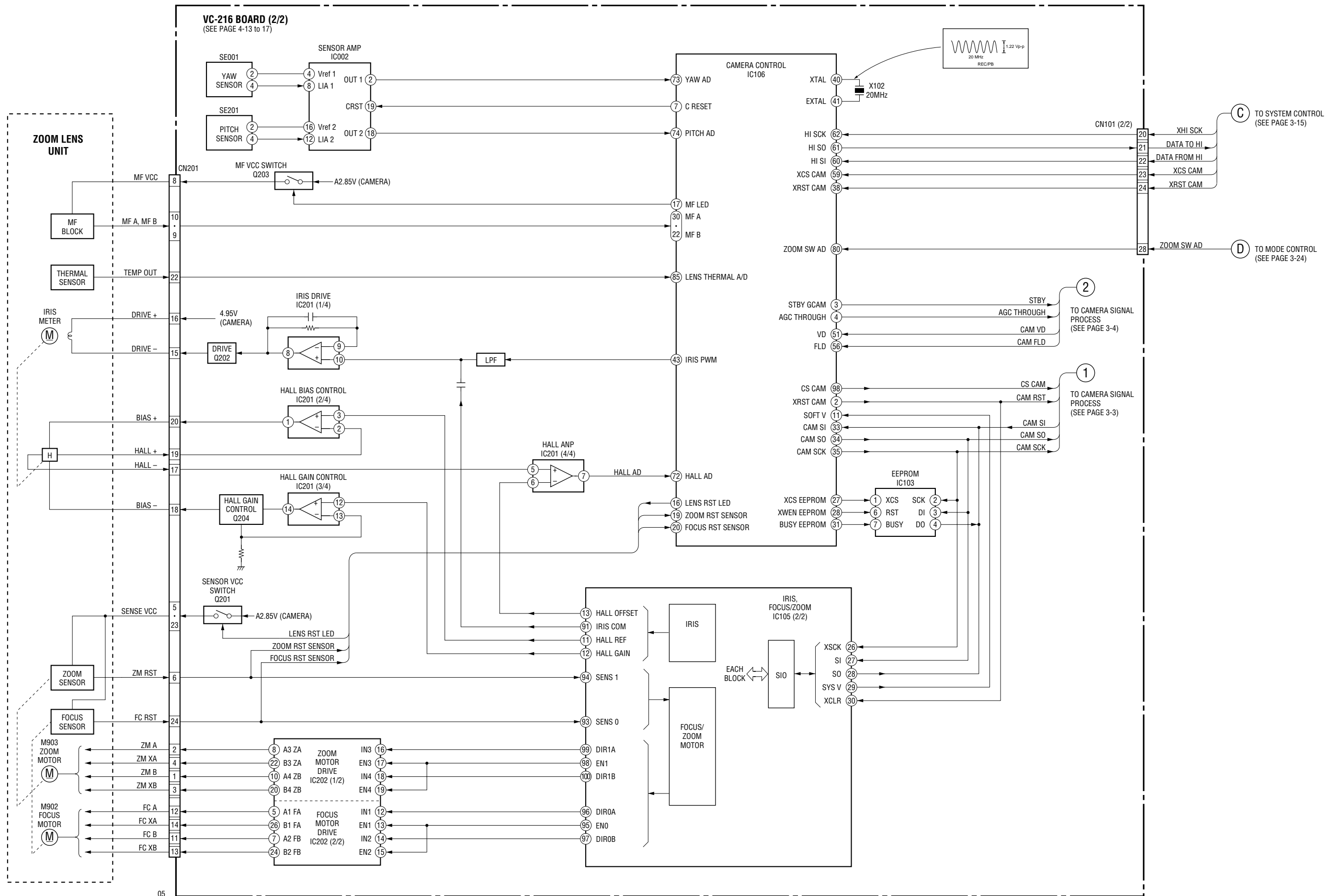

3-4. A/V DATA CONTROL, VIDEO OUT BLOCK DIAGRAM

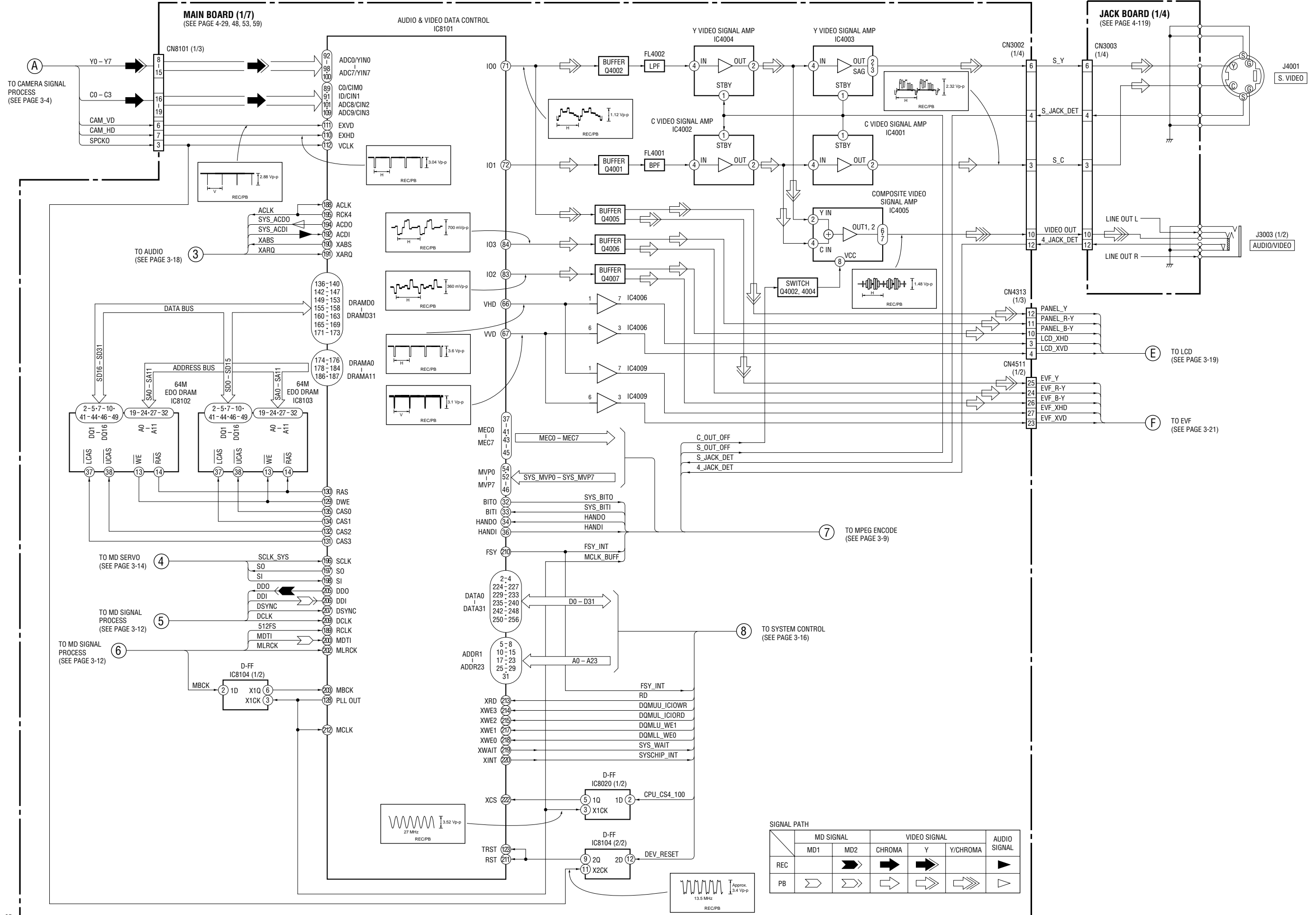

3-5. MPEG ENCODE BLOCK DIAGRAM

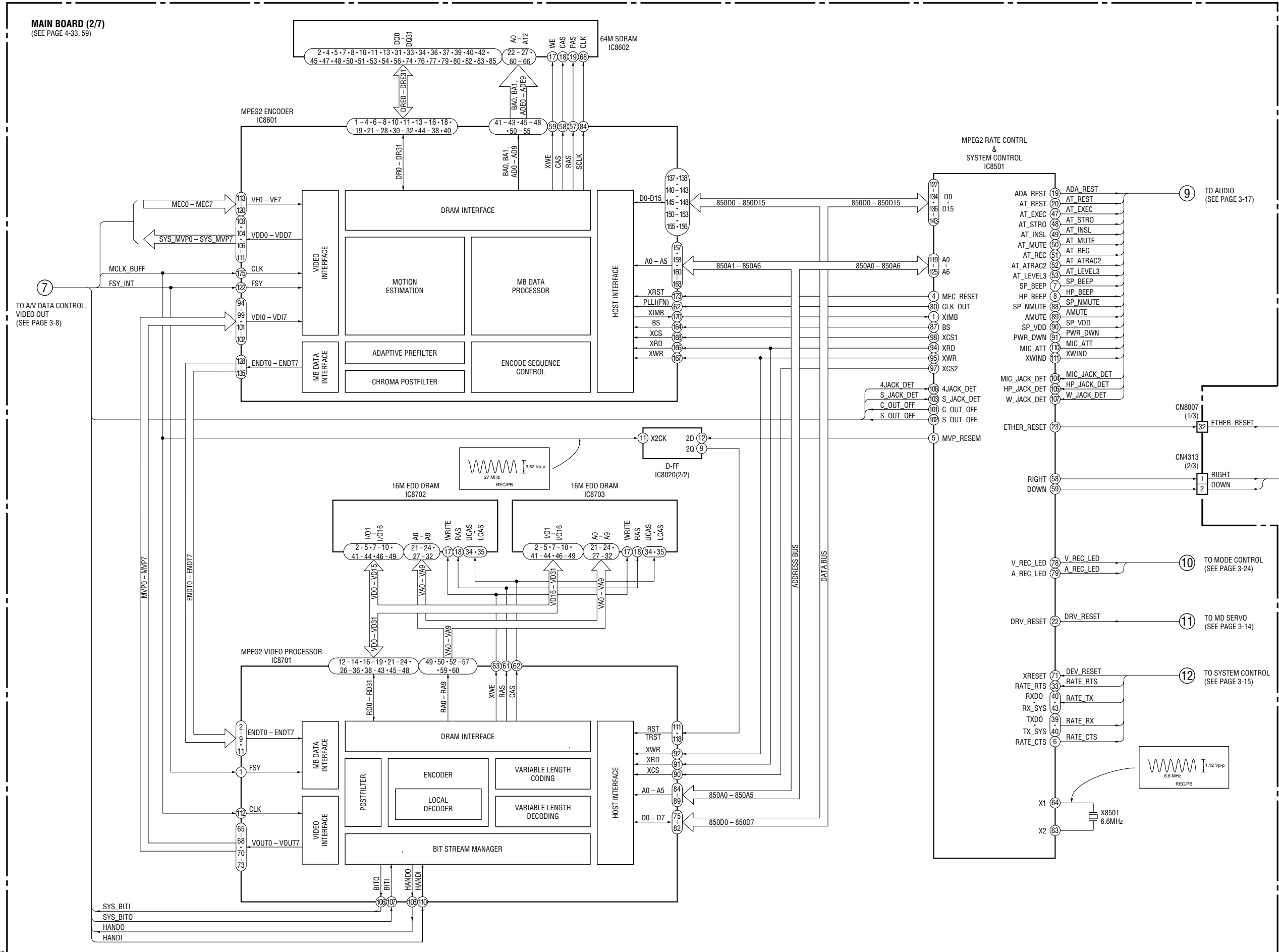

05



3-6. MD SIGNAL PROCESS BLOCK DIAGRAM

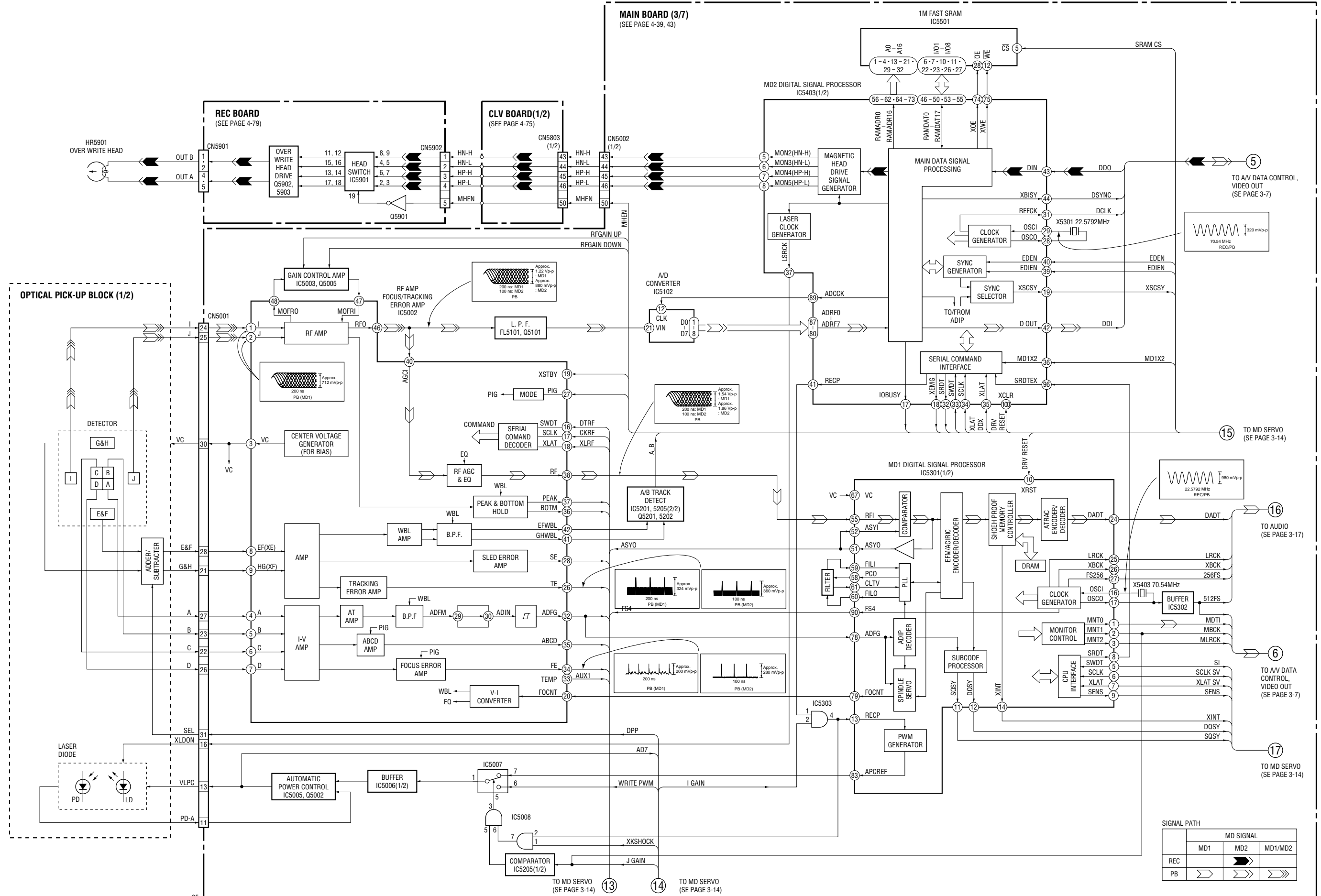

SIGNAL PATH

REC	MD SIGNAL		
	MD1	MD2	MD1/MD2
PB	→	→	→

3-7. MD SERVO BLOCK DIAGRAM

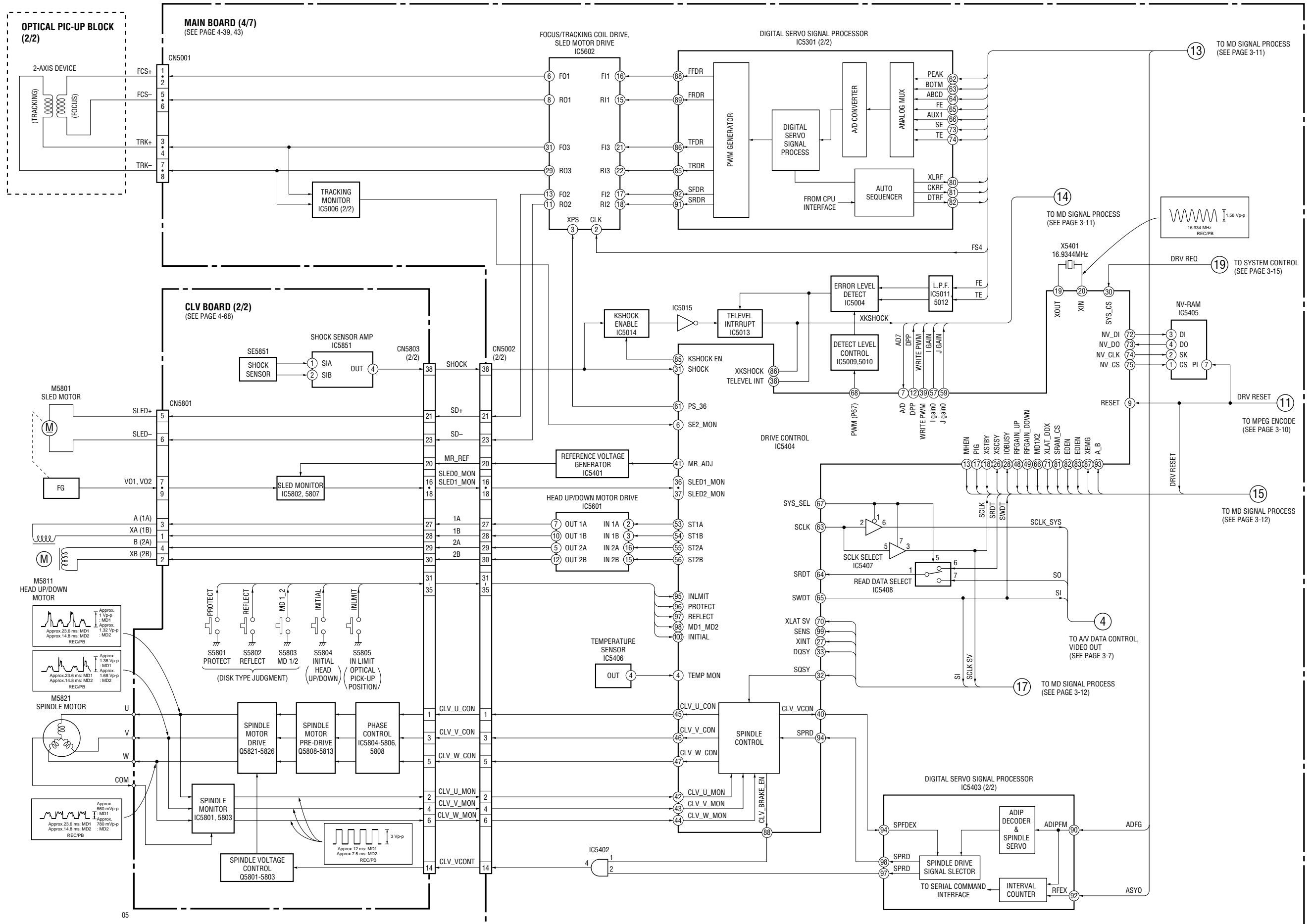

3-8. SYSTEM CONTROL BLOCK DIAGRAM

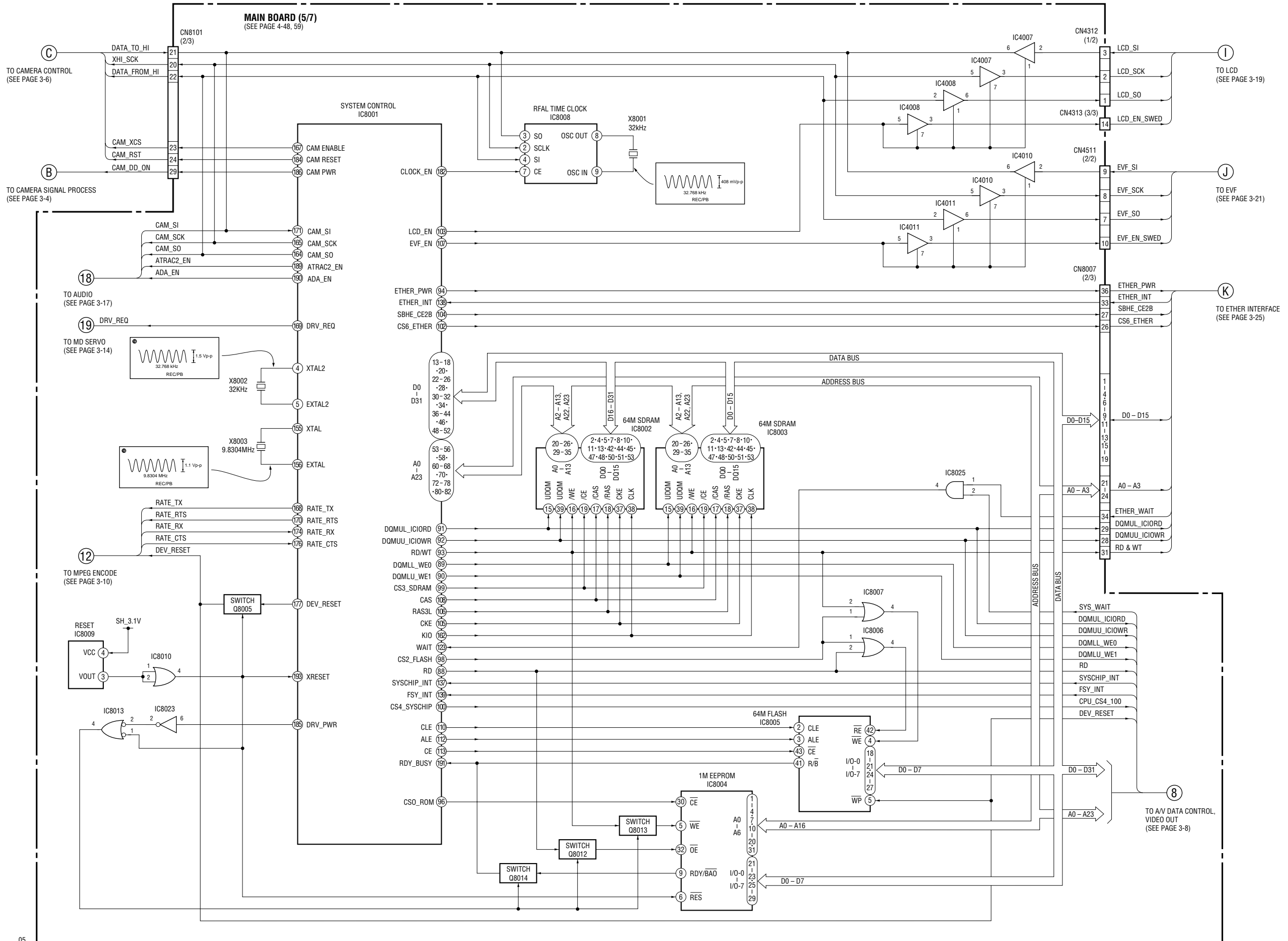

3-9. AUDIO BLOCK DIAGRAM

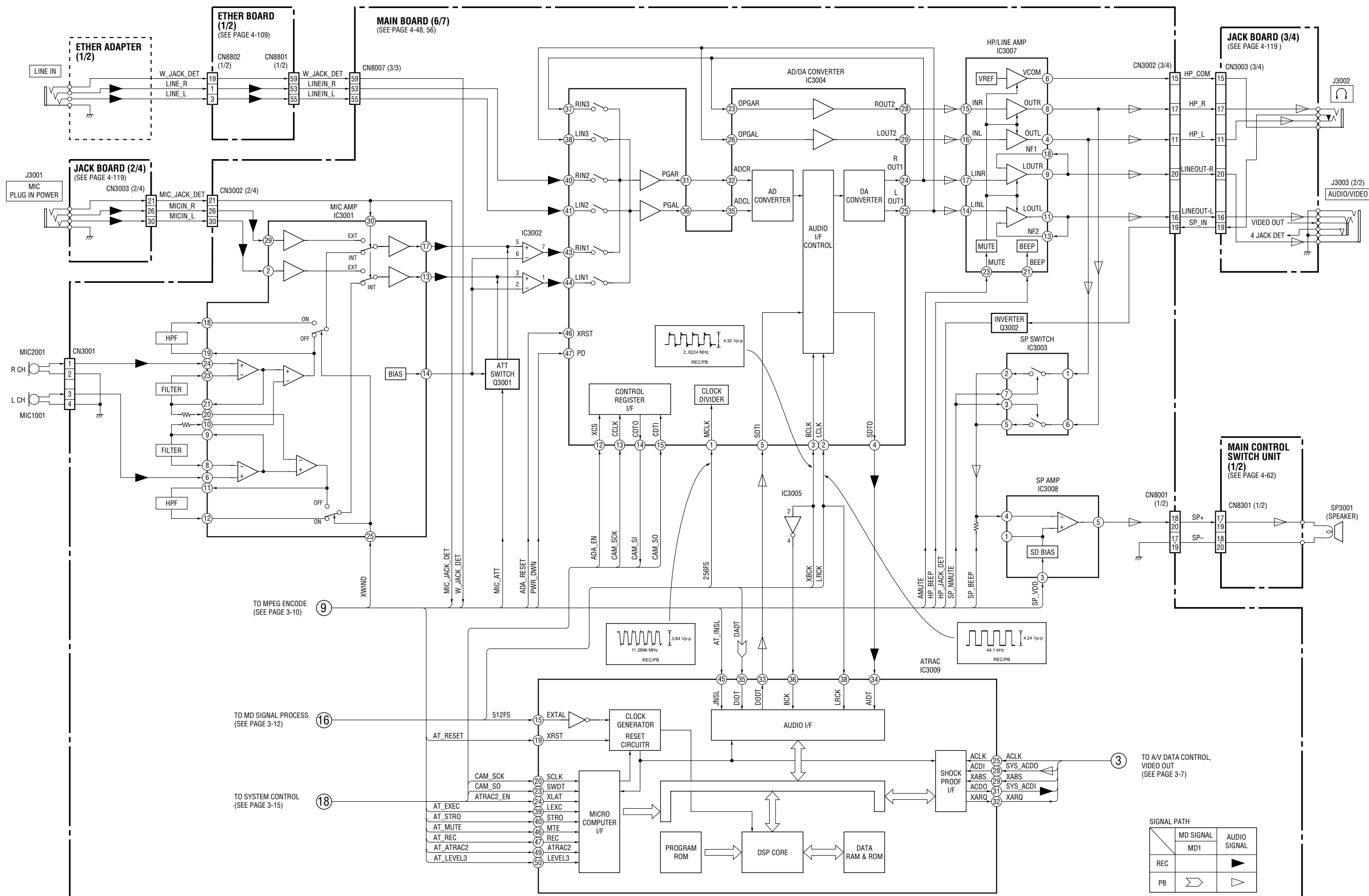

3-10. LCD BLOCK DIAGRAM

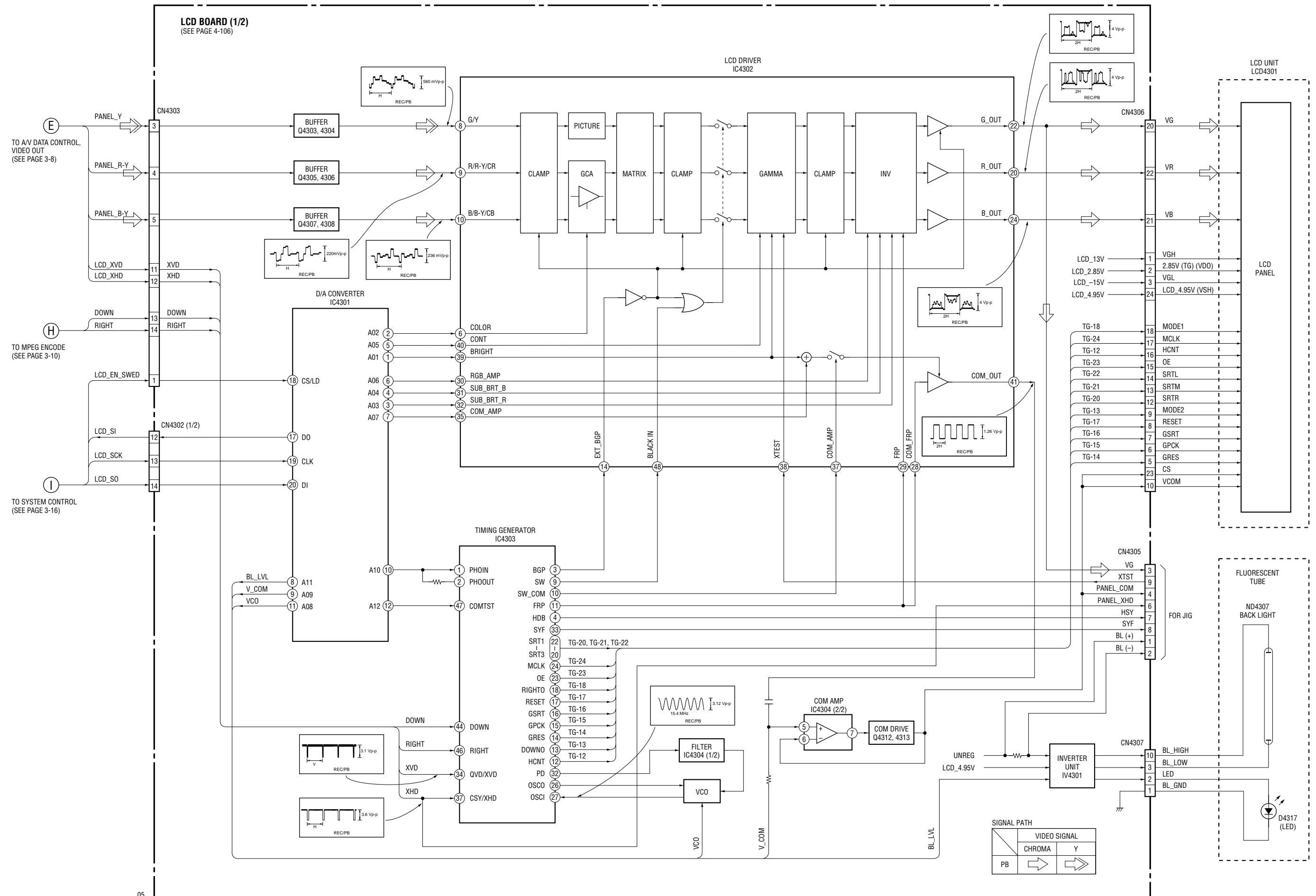

3-11. EVF BLOCK DIAGRAM

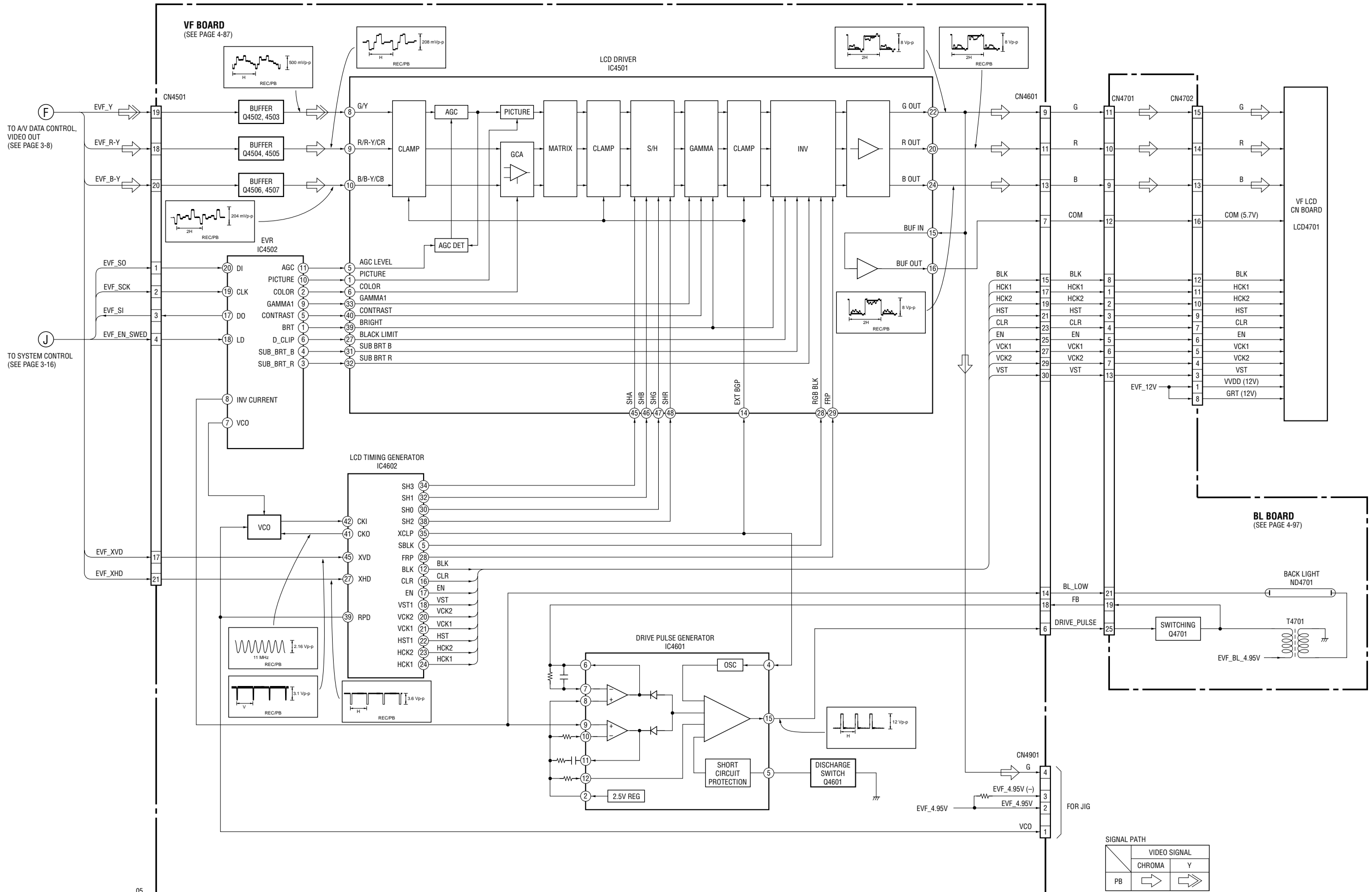

05

3-12. MODE CONTROL BLOCK DIAGRAM

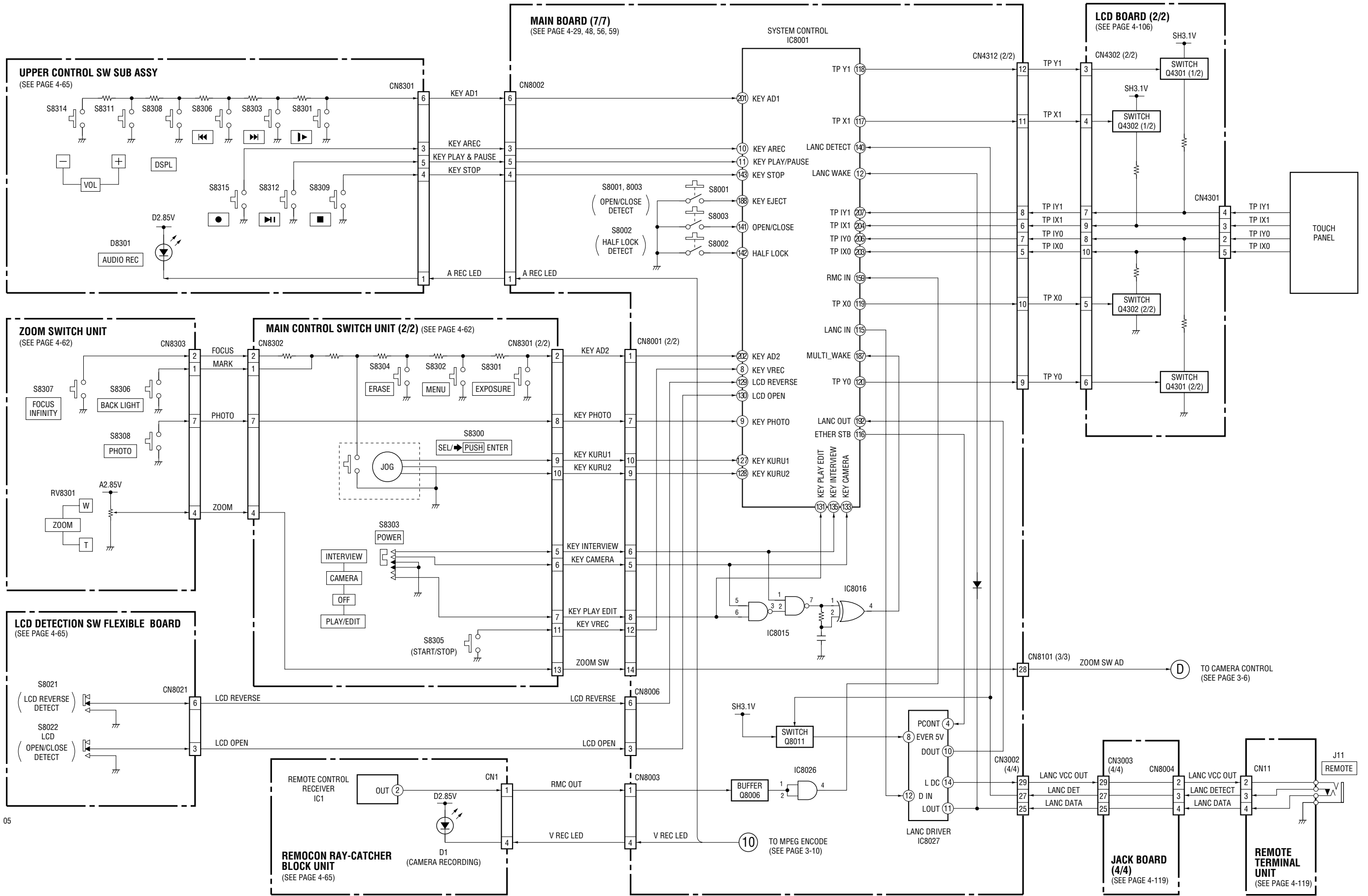

05

3-13. ETHER INTERFACE BLOCK DIAGRAM

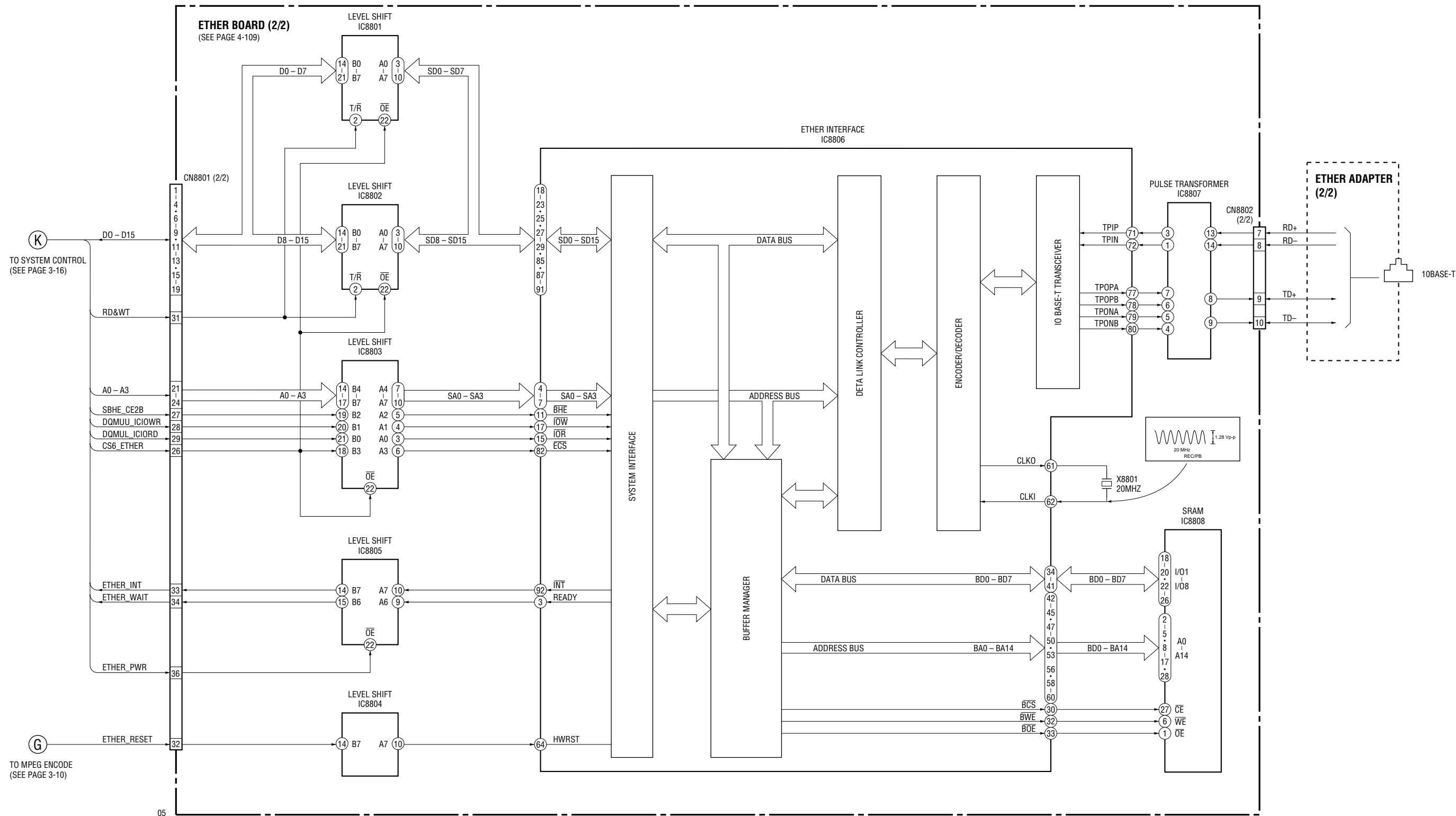

05



3-14. POWER 1 BLOCK DIAGRAM

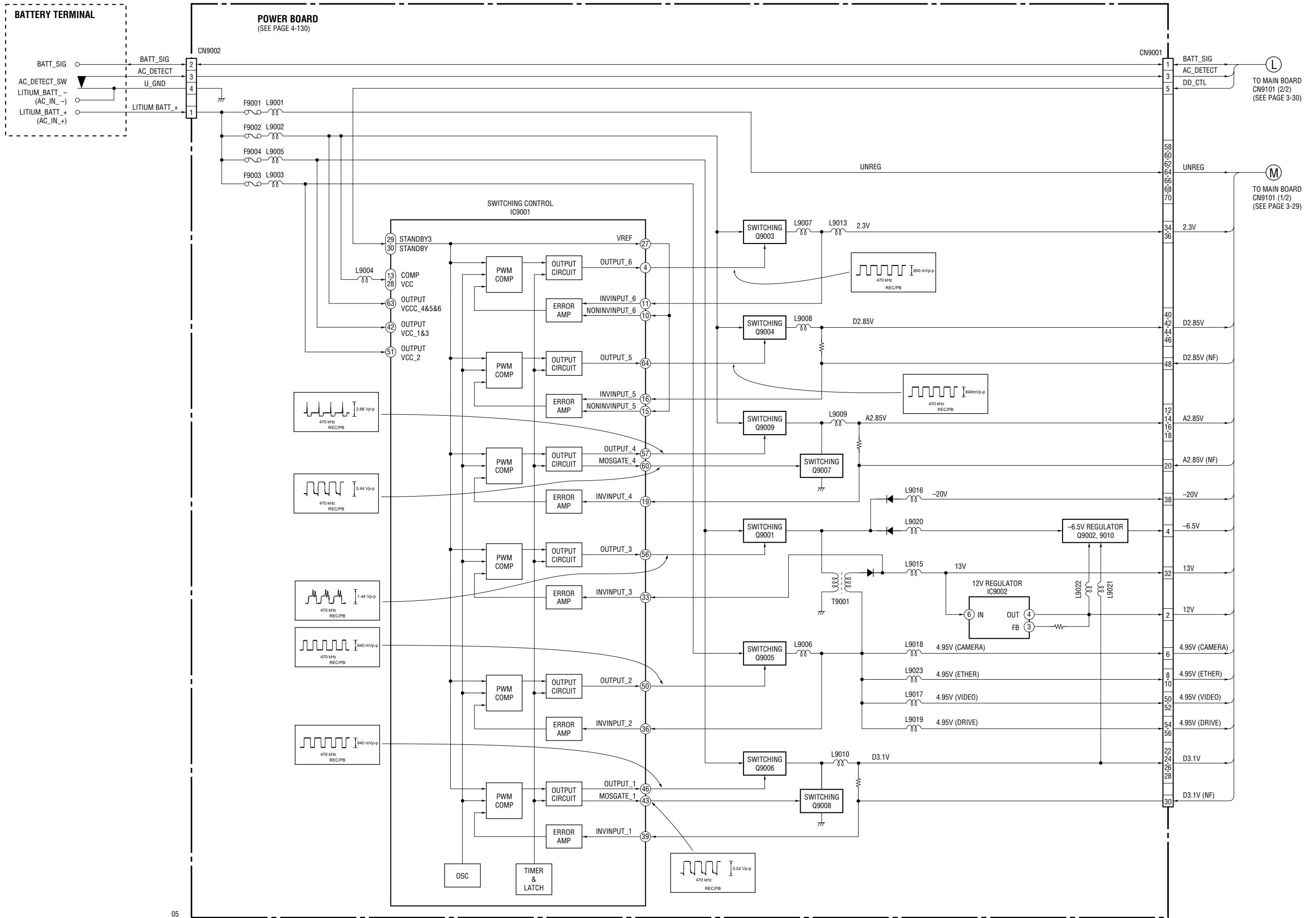

05

3-15. POWER 2 BLOCK DIAGRAM

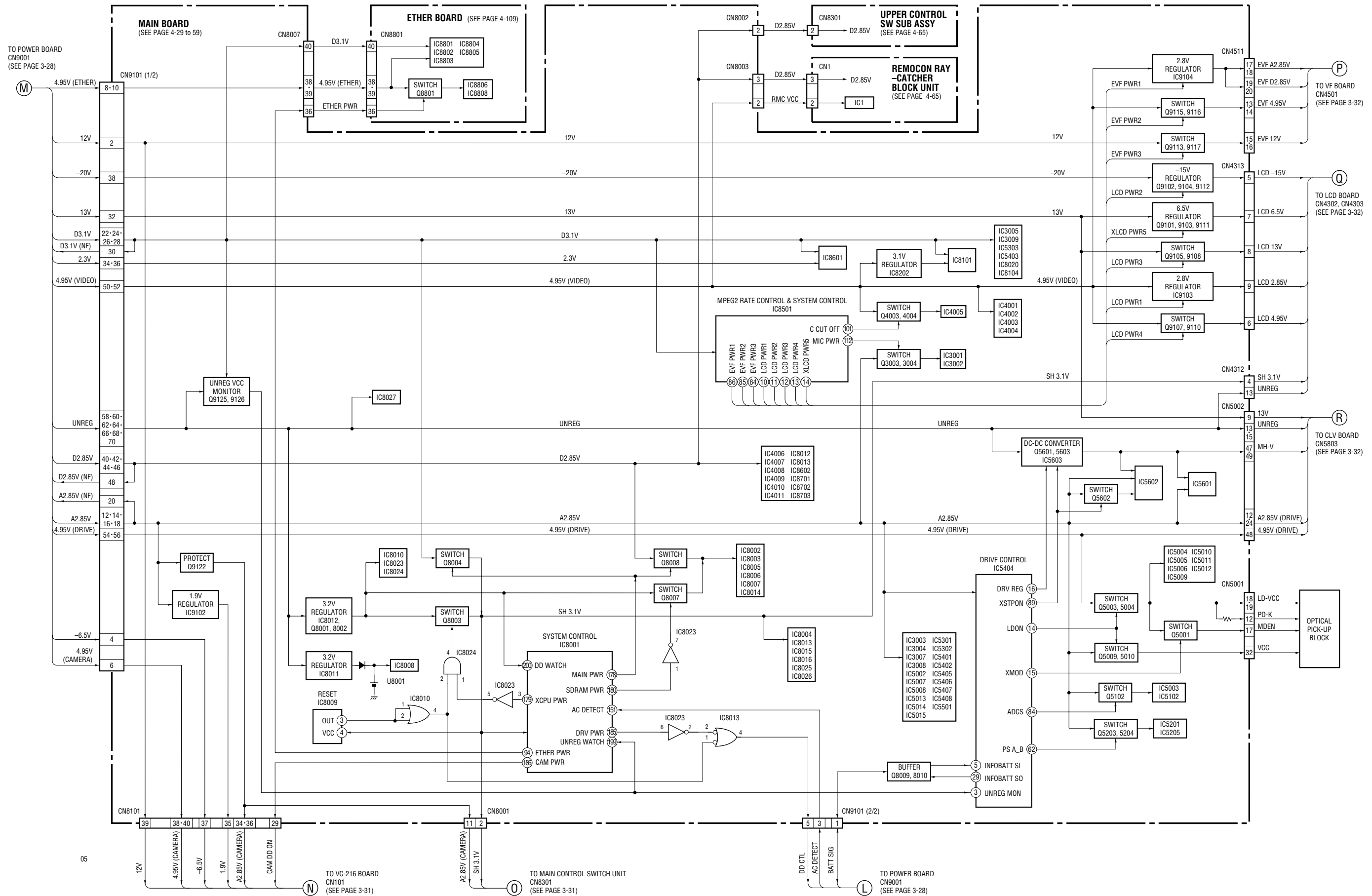

3-16. POWER 3 BLOCK DIAGRAM

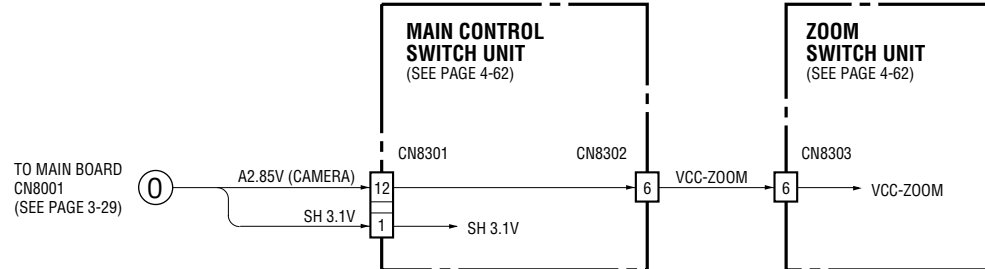
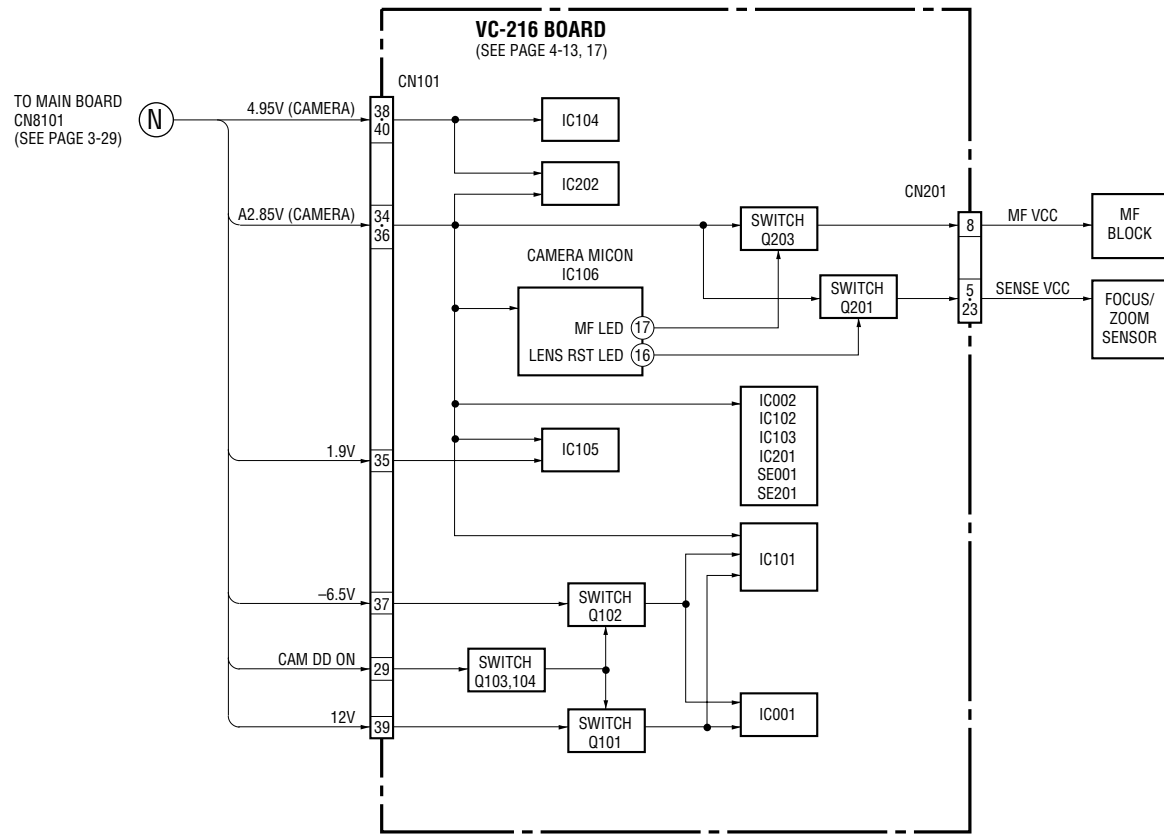

05

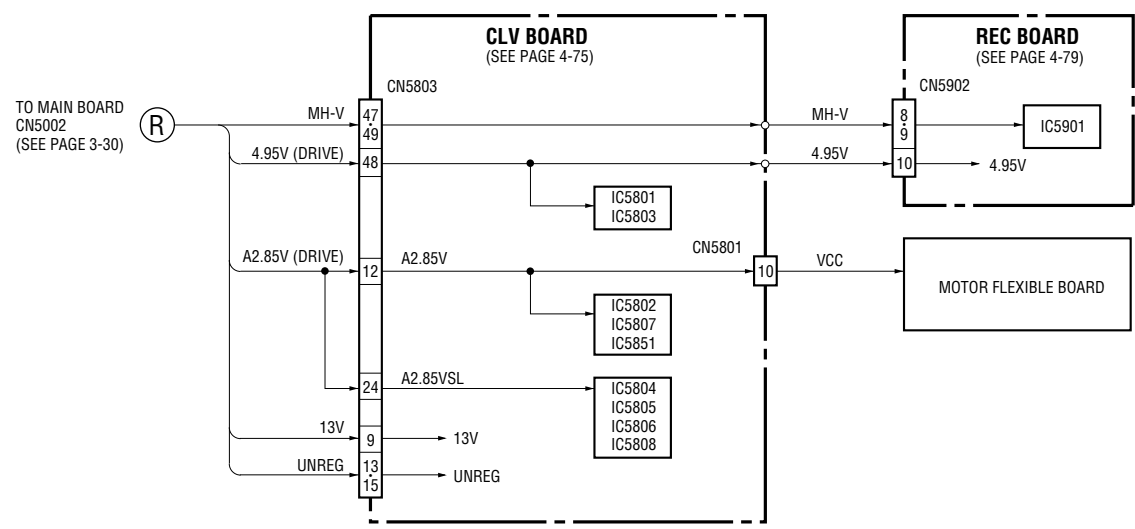
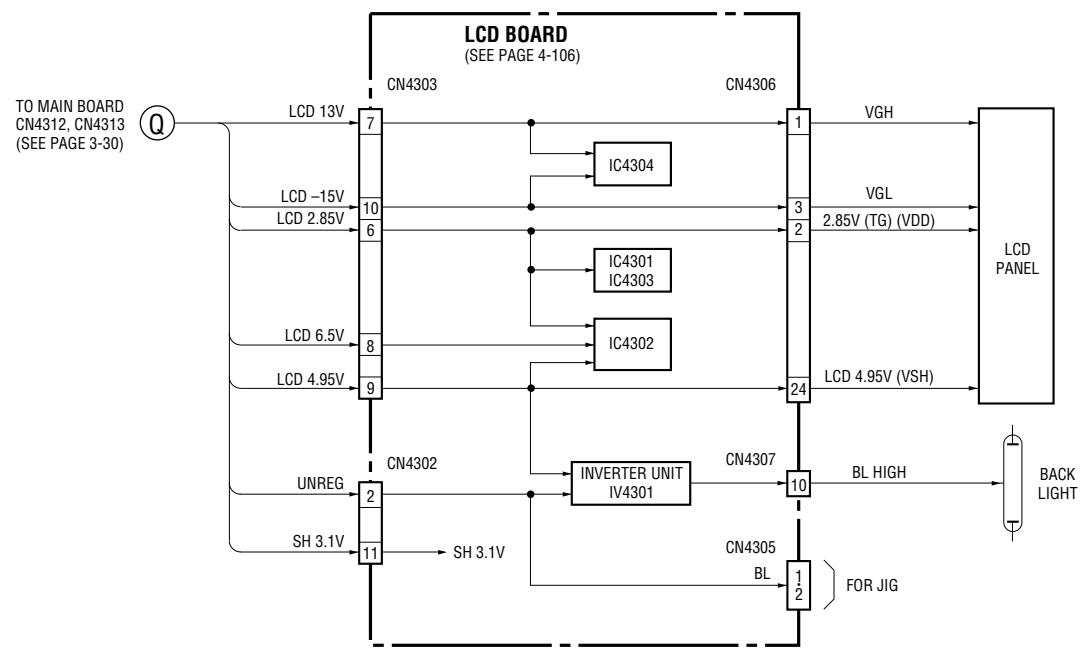
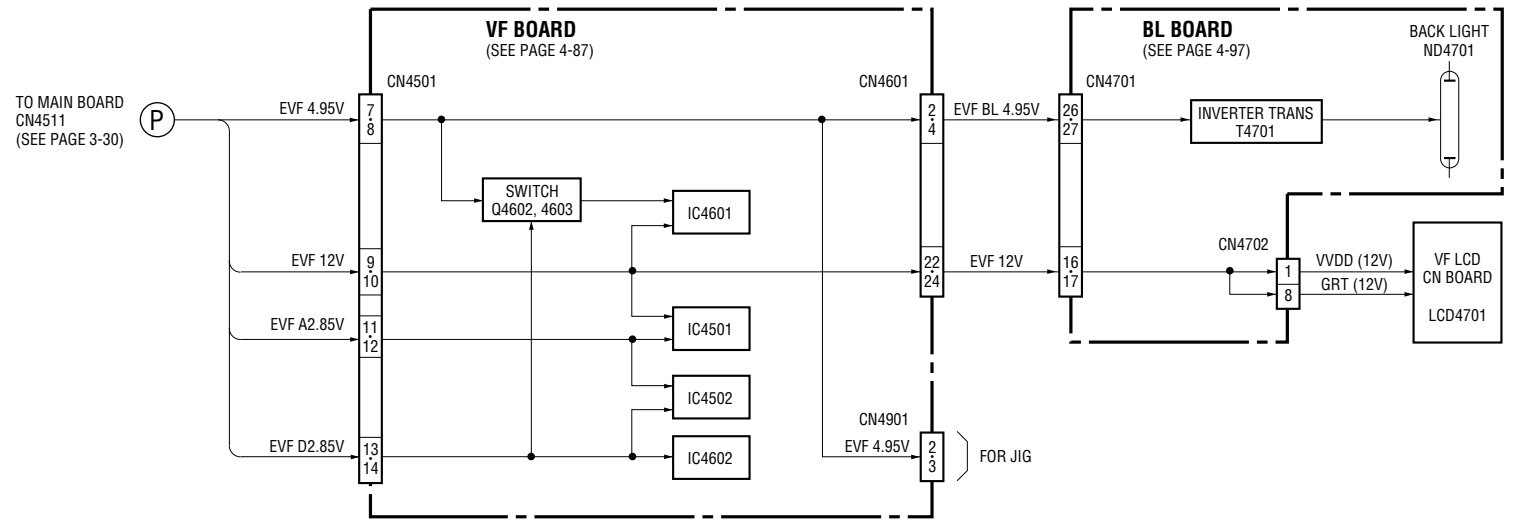

SECTION 4  
PRINTED WIRING BOARDS AND SCHEMATIC DIAGRAMS

**THIS NOTE IS COMMON FOR WIRING BOARDS AND SCHEMATIC DIAGRAMS**  
(In addition to this, the necessary note is printed in each block)

**(For printed wiring boards)**

- Pattern from the side which enables seeing.  
(The other layers' patterns are not indicated.)
- Through hole is omitted.
- Circled numbers refer to waveforms.
- There are few cases that the part printed on diagram isn't mounted in this model.
- Chip parts.

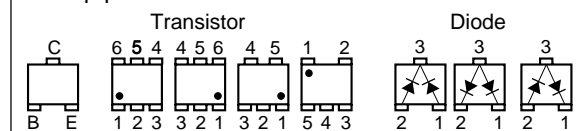

Lead Layouts

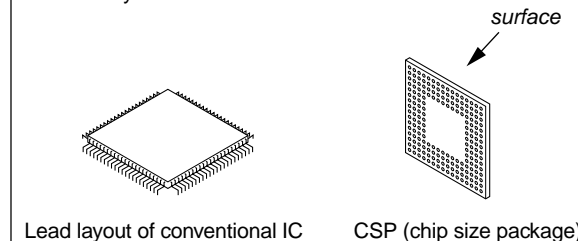

**(For schematic diagrams)**

- All capacitors are in  $\mu\text{F}$  unless otherwise noted.  $\text{pF}$  :  $\mu\text{F}$ . 50 V or less are not indicated except for electrolytics and tantalums.
- Chip resistors are 1/10 W unless otherwise noted.  $\text{k}\Omega=1000 \Omega$ ,  $\text{M}\Omega=1000 \text{k}\Omega$ .
- Caution when replacing chip parts. New parts must be attached after removal of chip. Be careful not to heat the minus side of tantalum capacitor, because it is damaged by the heat.
- Some chip part will be indicated as follows.

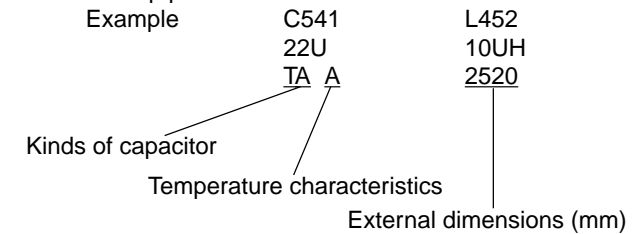

- Constants of resistors, capacitors, ICs and etc with XX indicate that they are not used. In such cases, the unused circuits may be indicated.
- Parts with  $\star$  differ according to the model/destination. Refer to the mount table for each function.
- All variable and adjustable resistors have characteristic curve B, unless otherwise noted.
- Signal name  
XEDIT  $\rightarrow$  EDIT PB/XREC  $\rightarrow$  PB/REC
- non flammable resistor
- fusible resistor
- panel designation
- B+ : B+ Line
- B- : B- Line
- adjustment for repair.
- Circled numbers refer to waveforms.
- The voltage and waveform of CSP (chip size package) cannot be measured, because its lead layout is different form that of conventional IC.

**Note:**  
The components identified by mark  $\Delta$  or dotted line with mark  $\Delta$  are critical for safety. Replace only with part number specified.

**Note:**  
Les composants identifiés par une marque  $\Delta$  sont critiques pour la sécurité. Ne les remplacer que par une pièce portant le numéro spécifié.

When indicating parts by reference number, please include the board name.

**(Measuring conditions voltage and waveform)**

- MD1 PB :
  - Voltages are dc between measurement point.
  - Readings are taken when playing CD reference disc.
- MD2 REC/PB :
  - Voltages and waveforms are measured between the measurement points and ground when camera shoots color bar chart of pattern box. They are reference values and reference waveforms. (VOM of DC 10 M $\Omega$  input impedance is used)
  - Voltage values change depending upon input impedance of VOM used.)

1. Connection  
Pattern box

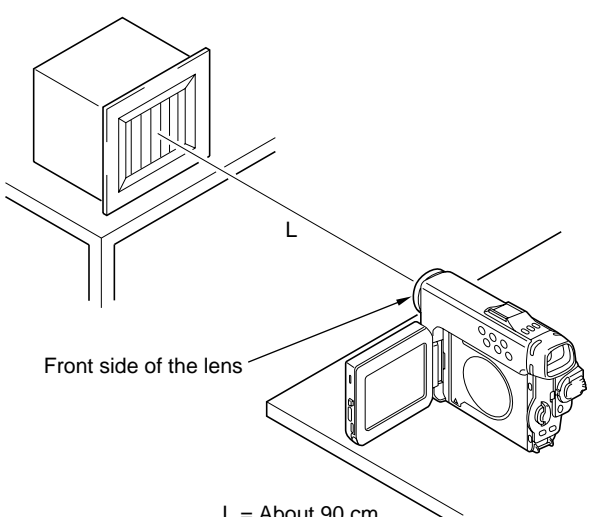

2. Adjust the distance so that the output waveform of Fig. a and the Fig. b can be obtain.

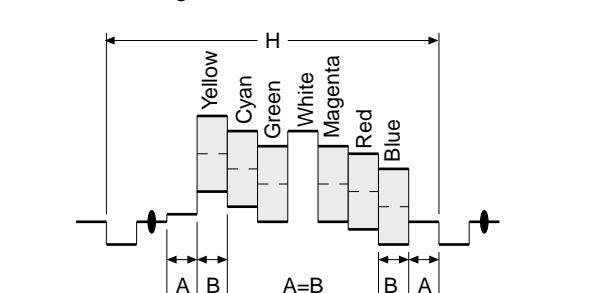

Fig. a (Video output terminal output waveform)

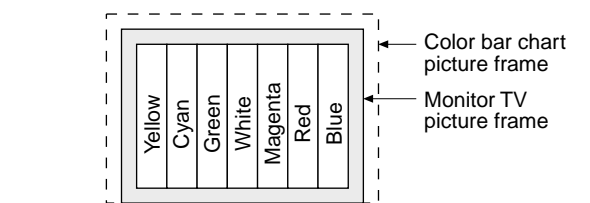
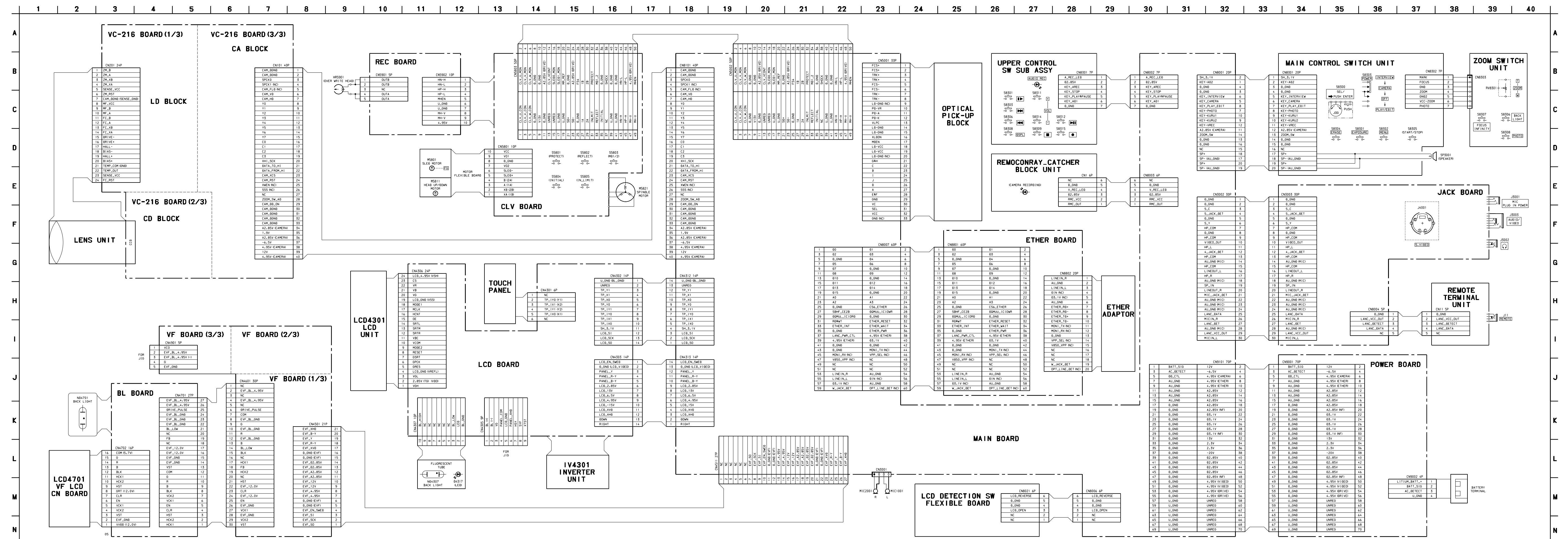

Fig.b (Picture on monitor TV)

4-1. FRAME SCHEMATIC DIAGRAM



4-2. PRINTED WIRING BOARDS AND SCHEMATIC DIAGRAMS

VC-216 (LENS MOTOR DRIVE, CCD IMAGER, CAMERA SIGNAL PROCESS) PRINTED WIRING BOARD
- Ref. No.: VC-216 board; 20,000 series -

VC-216 BOARD (SIDE A)

Table listing component designations and locations for Side A, including IC105, IC201, L001, L101, L103, Q001, Q101, Q102, Q103, Q104, Q202, Q204, R005, R007, R009, R010, R011, R015, R107, R115, R116, R118, R119, R123, R135, R138, R203, R206, R208, R209, R210, R211, R213, R215, R218, R219, R220, R221, R222, R224, R225, R226, CN201, FB103, FB104, FB105, IC102, IC103.

VC-216 BOARD (SIDE A)

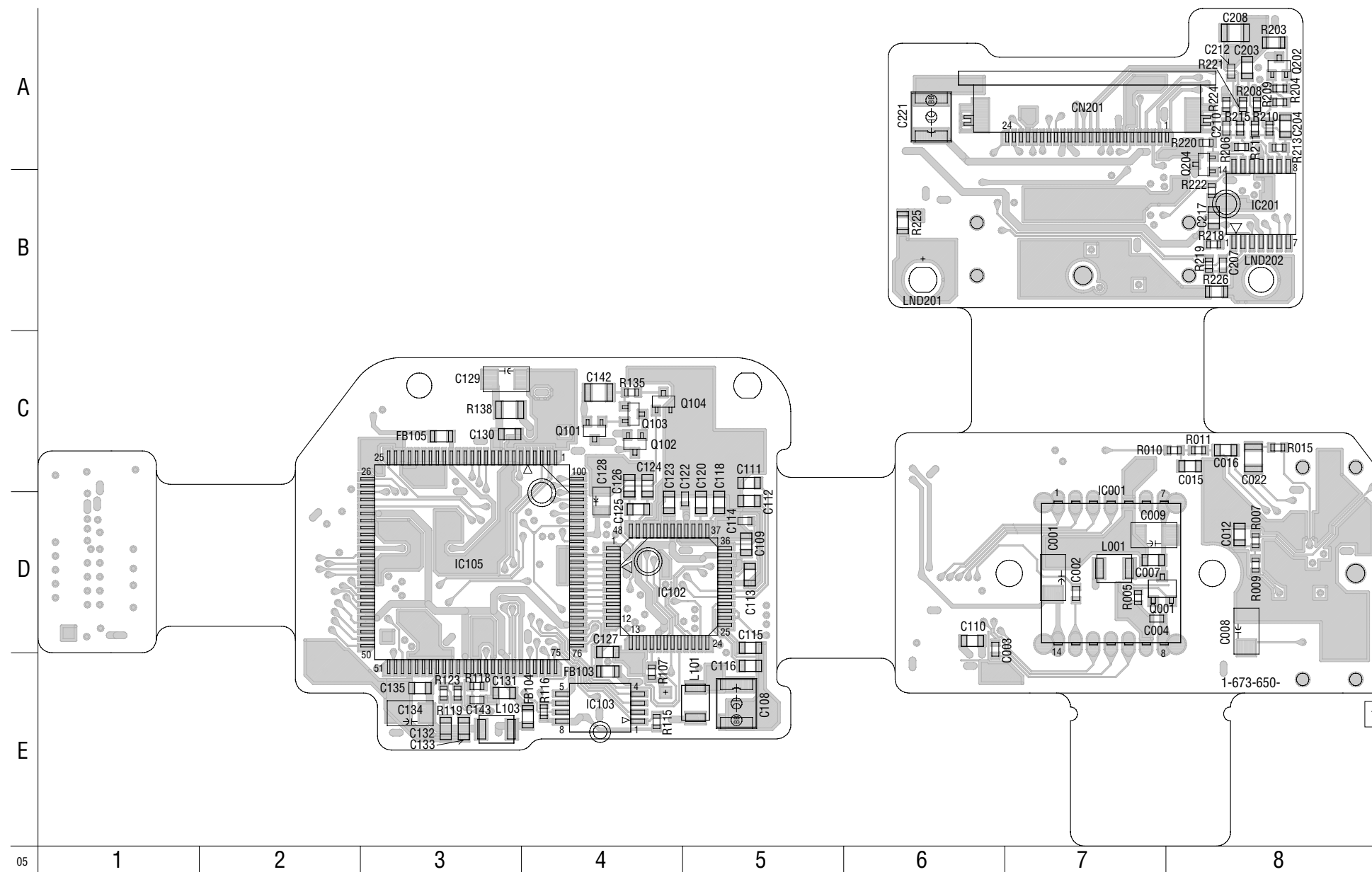

For Printed Wiring Board.
There are few cases that the part isn't mounted in this model is printed on this diagram.
Chip transistor

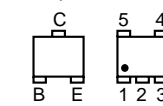

VC-216 BOARD (SIDE B)

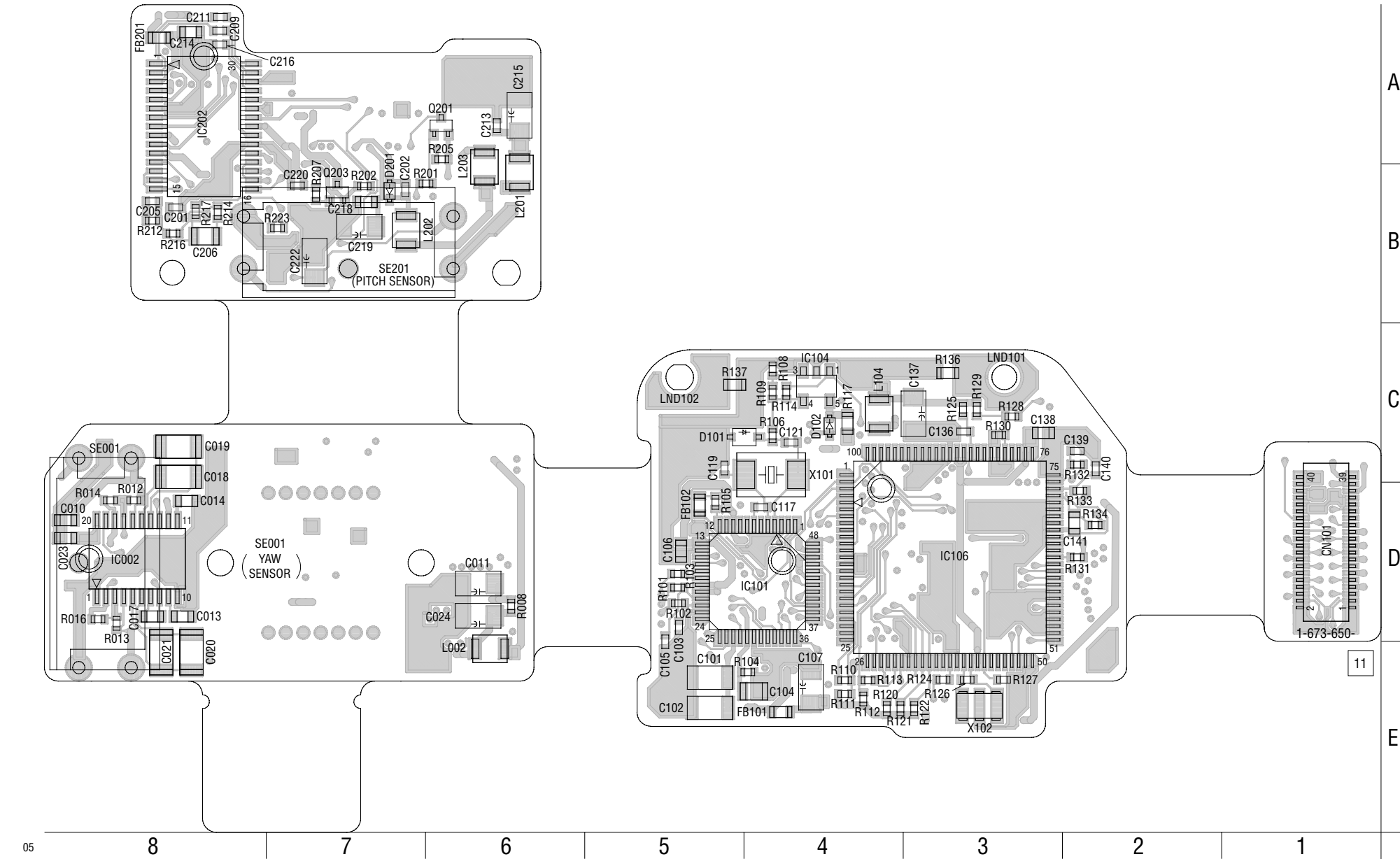

VC-216 BOARD (SIDE B)

Table listing component designations and locations for Side B, including C208, R203, C212, C203, R220, R221, R222, R223, R224, R225, R226, LND201, LND202, C216, IC201, C213, L201, C215, C205, C201, R212, R216, C206, C220, C207, R227, C218, C219, SE201, L208, C214, C217, C218, C219, SE201 (PITCH SENSOR), LND101, LND102, R137, R109, IC104, R136, LND101, R128, R138, C138, C139, C140, C141, D-2, R129, C-3, C201, B-8, R130, C-3, C202, B-7, R131, D-2, C203, B-8, R132, C-2, C206, B-8, R133, D-2, C209, A-8, R134, D-2, C211, A-8, R136, C-3, C213, A-6, R137, C-5, C214, A-8, R201, B-7, C215, A-6, R202, B-7, C216, A-8, R205, A-6, C218, B-7, R207, B-7, C219, B-7, R212, B-8, C220, B-7, R214, B-8, C222, B-7, R216, B-8, R217, B-8, R223, B-7, CN101, D-1, D101, C-4, X101, C-4, D201, B-7, X102, E-3, FB101, E-4, FB102, D-5, FB201, A-8, IC002, D-8, IC101, D-4, IC104, C-4, IC106, D-3, IC202, A-8, L002, E-6, L104, C-4, L201, B-6, L202, B-7, L203, B-6, Q201, A-6, Q203, B-7.

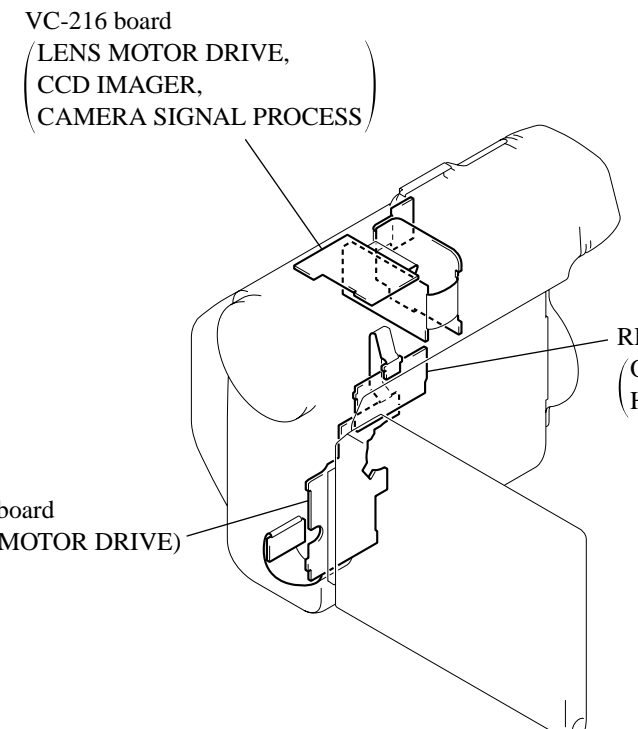

VC-216 (LENS MOTOR DRIVE, CCD IMAGER) SCHEMATIC DIAGRAM • See page 4-9 for VC-216 printed wiring board. • See page 4-133 for waveforms.

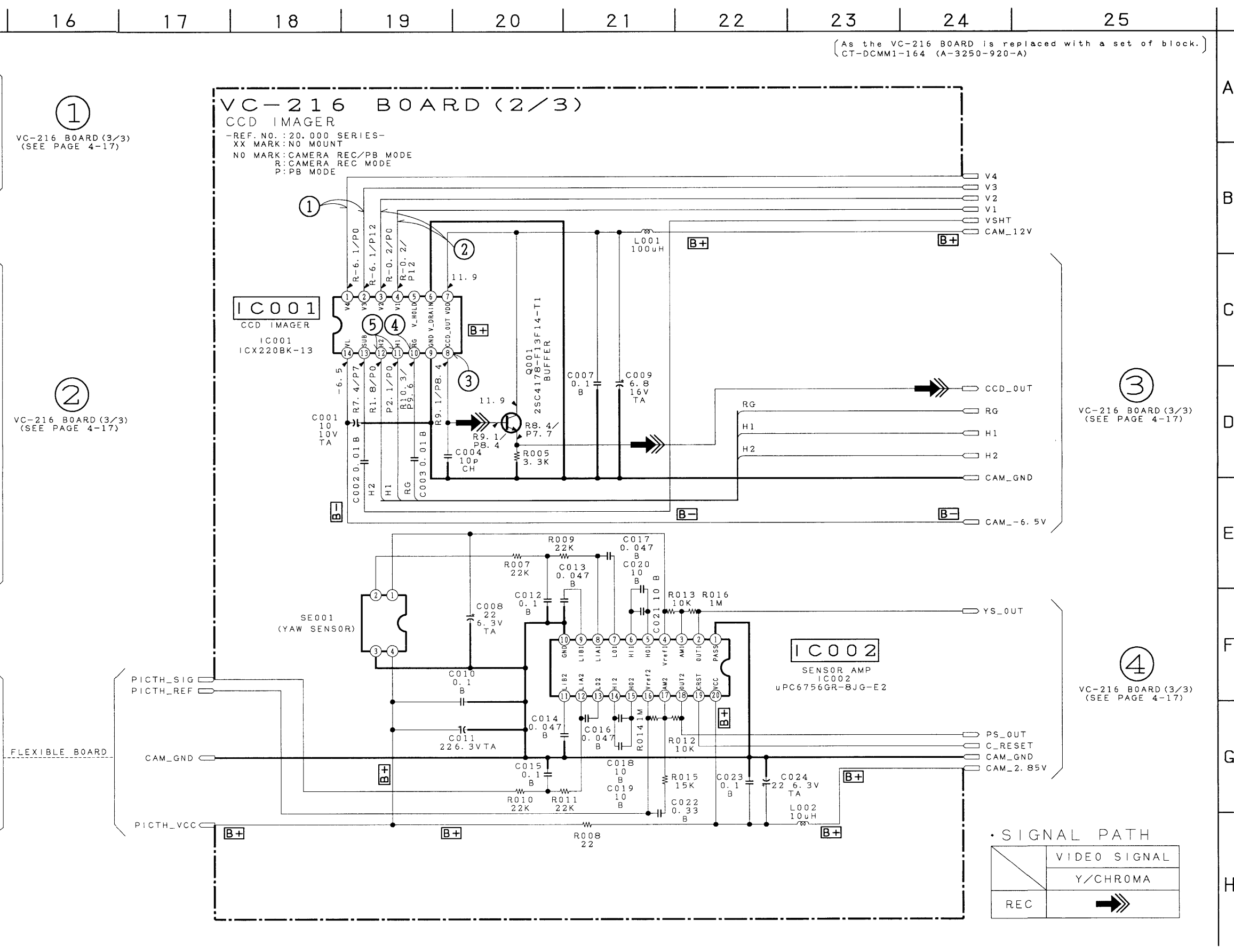
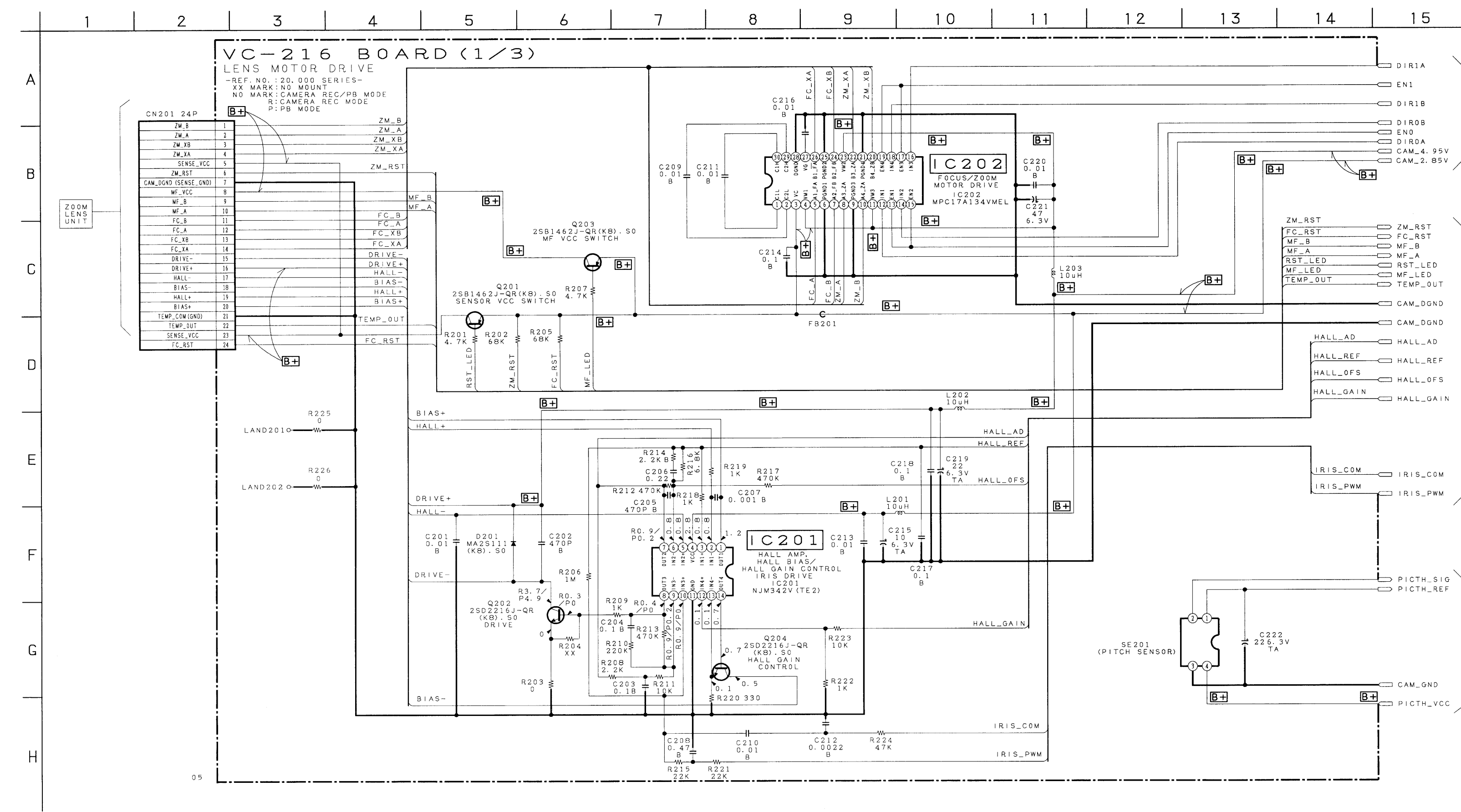

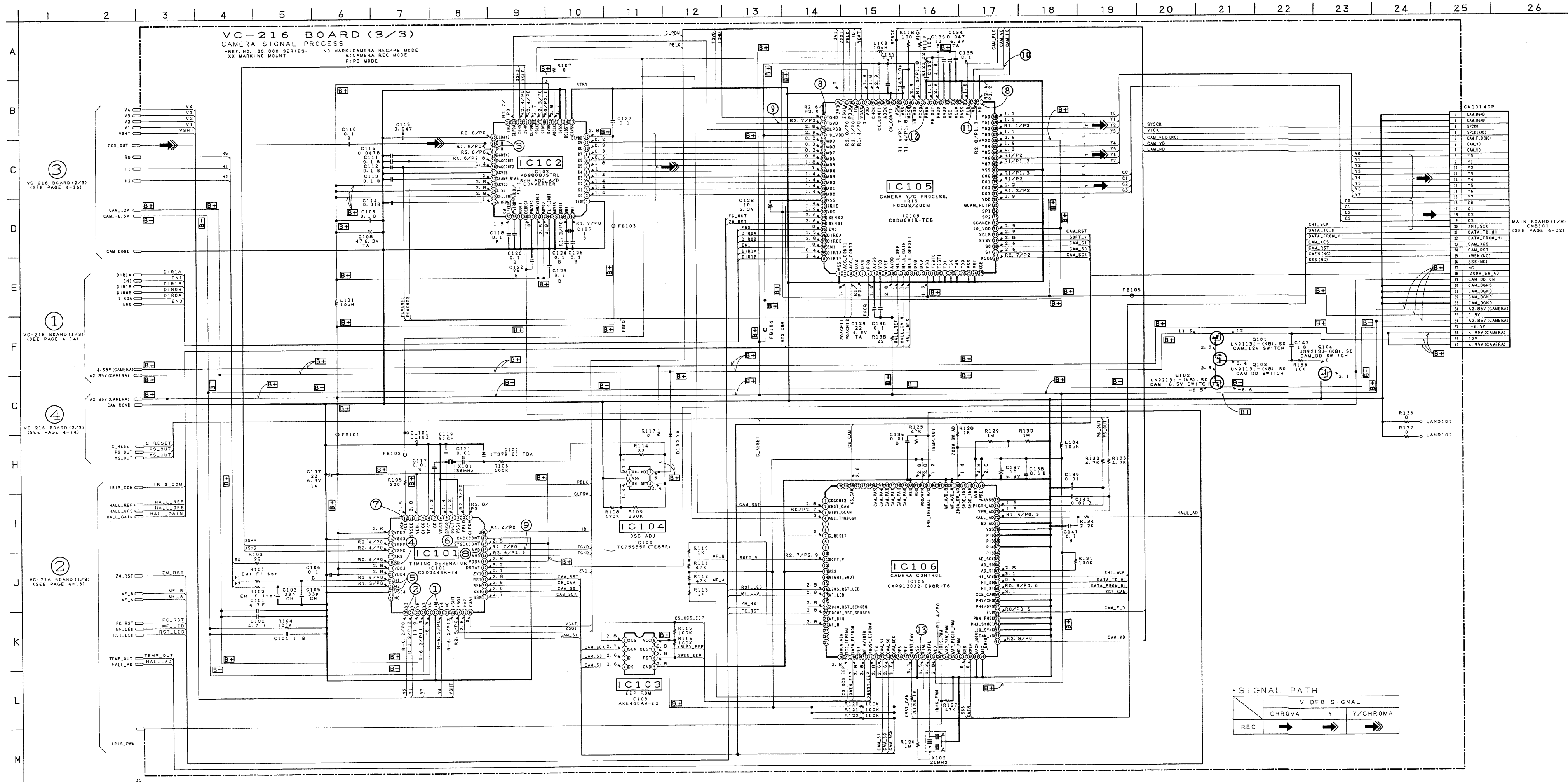



MAIN (AUDIO/VIDEO DATA CONTROL, MPEG ENCODER/DECODER, RF AMP/DRIVE, DIGITAL SIGNAL PROCESSOR, SYSTEM CONTROL, VIDEO, AUDIO, SWITCHING REGULATOR) PRINTED WIRING BOARD - Ref. No.: MAIN board; 10,000 series -

MAIN BOARD (SIDE A)

Table of component callouts for MAIN BOARD (SIDE A), listing part numbers and locations (e.g., C1003 G-8, C4023 G-4, C5603 E-3, FB8003 B-8, L8103 E-6, R2026 F-5, R5308 C-2, R8910 H-2).

- For Printed Wiring Board.
There are few cases that the part isn't mounted in this model is printed on this diagram.
Chip transistor

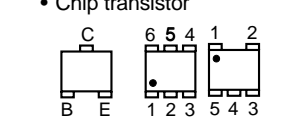

Lead Layouts

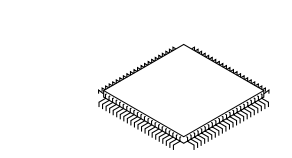

Lead layout of conventional IC

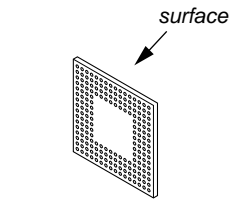

CSP (chip size package)

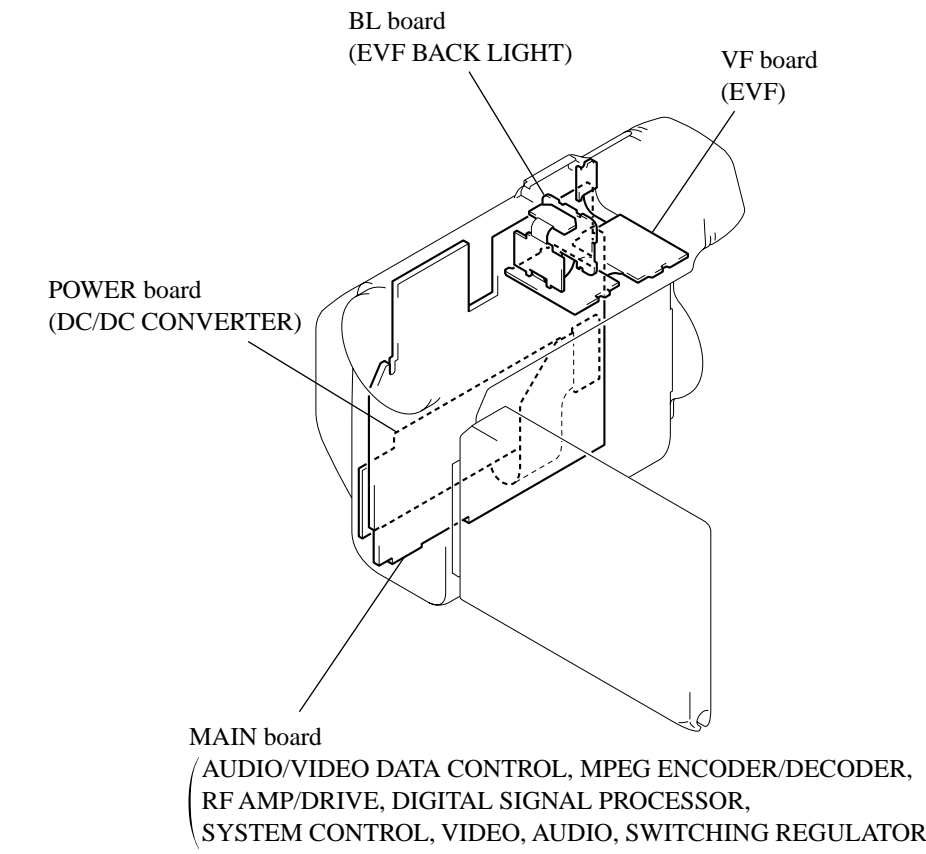

MAIN BOARD (SIDE A)

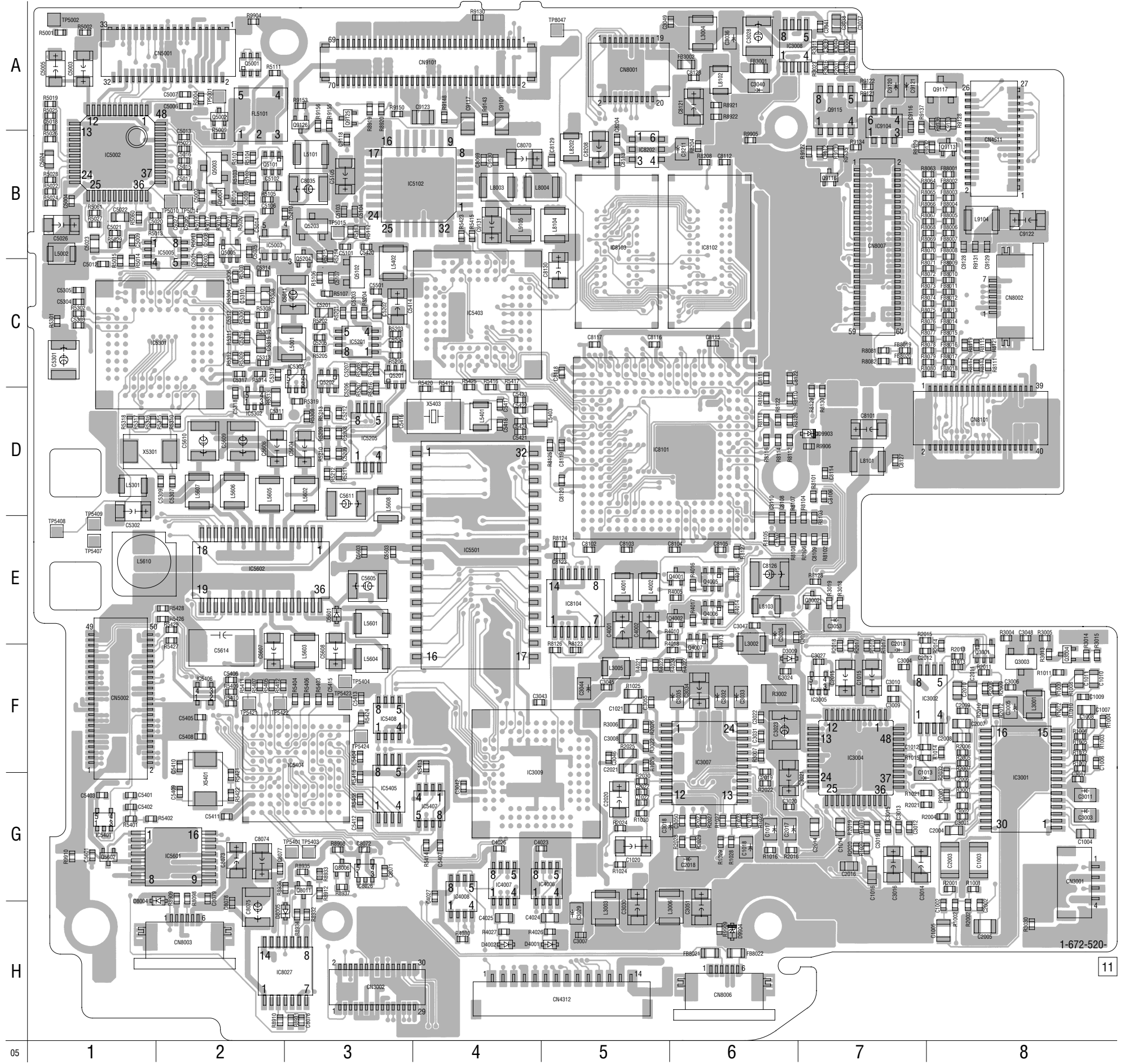



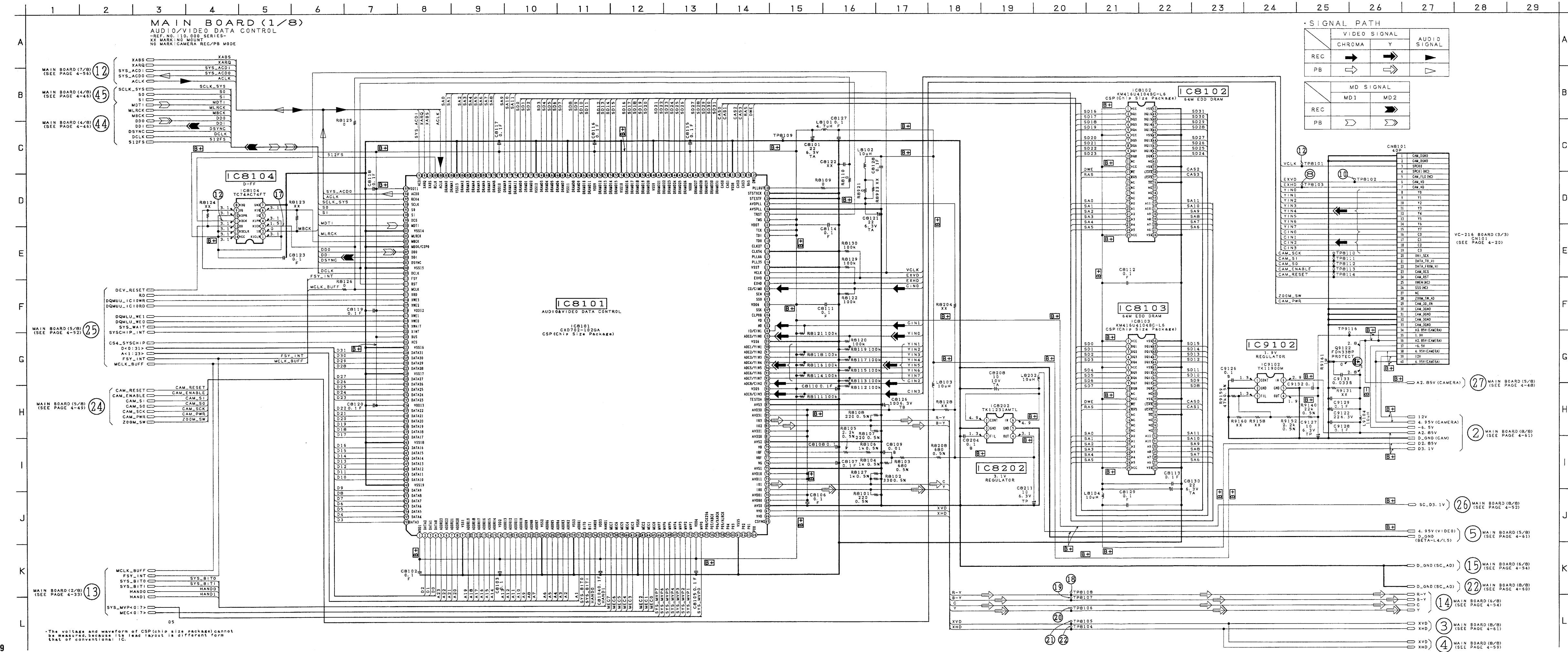

\*The voltage and waveform of CSP (chip size package) cannot be measured, because its lead layout is different from that of conventional IC.

MAIN (MPEG ENCODER/DECODER) SCHEMATIC DIAGRAM • See page 4-21 for MAIN printed wiring board. • See page 4-133 for waveforms.

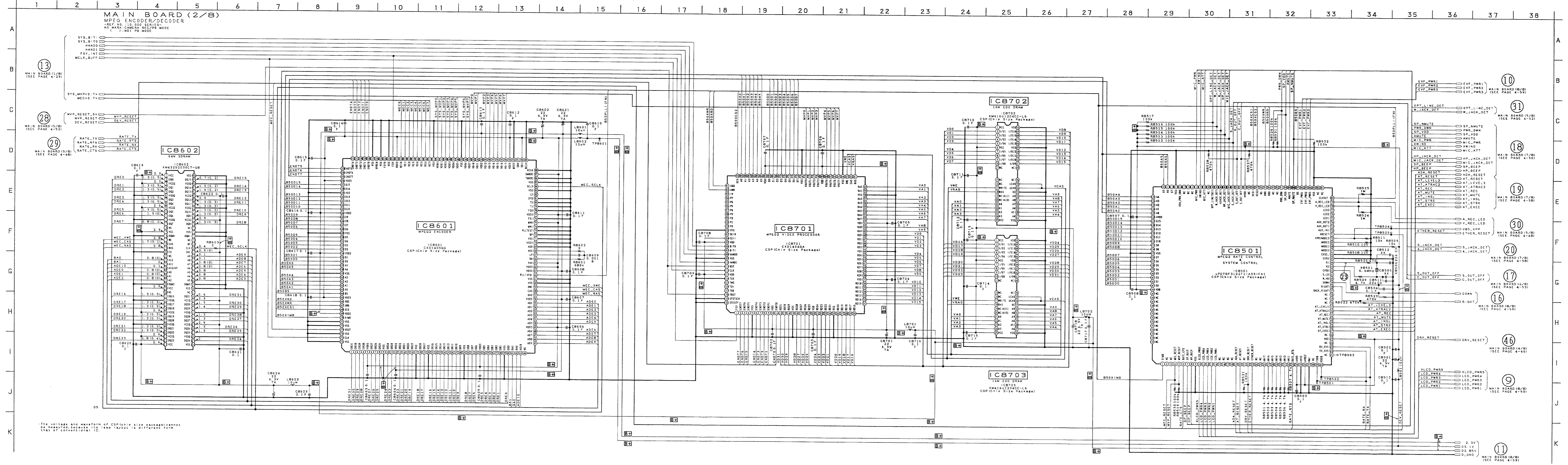

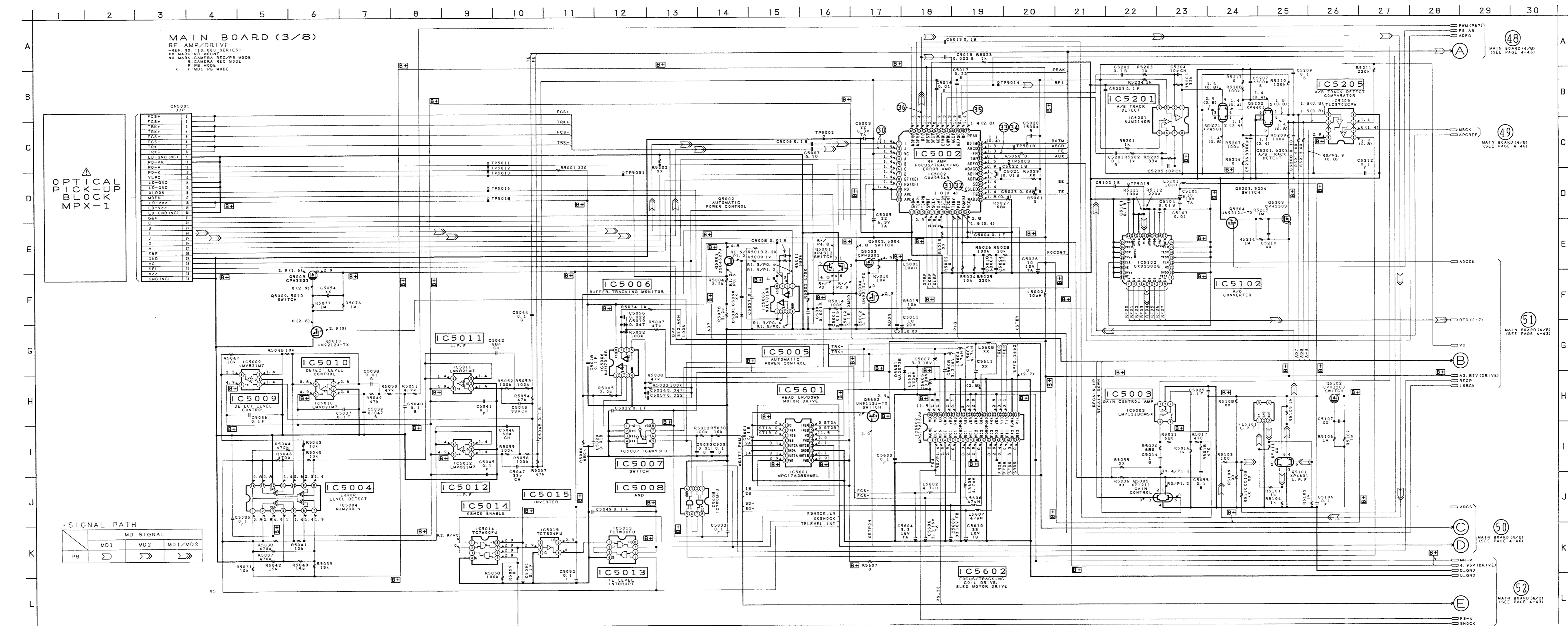

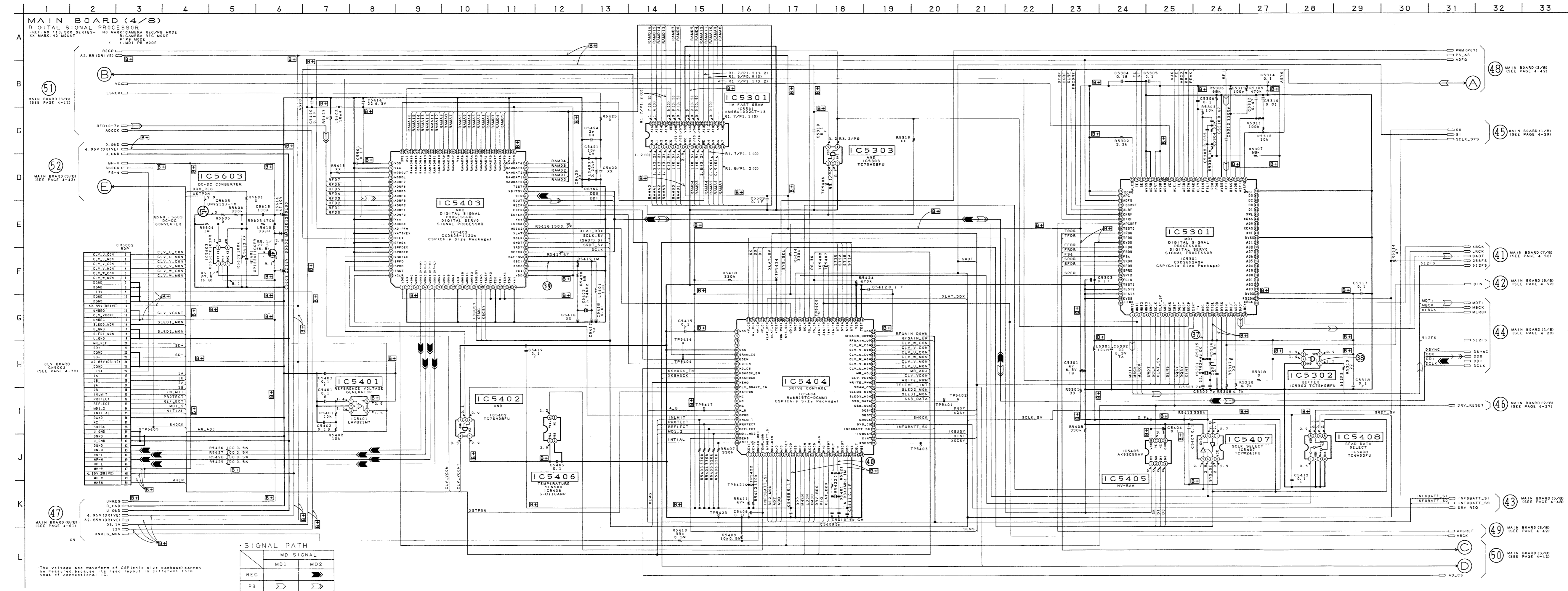

MAIN (SYSTEM CONTROL) SCHEMATIC DIAGRAM • See page 4-21 for MAIN printed wiring board. • See page 4-133 for waveforms.

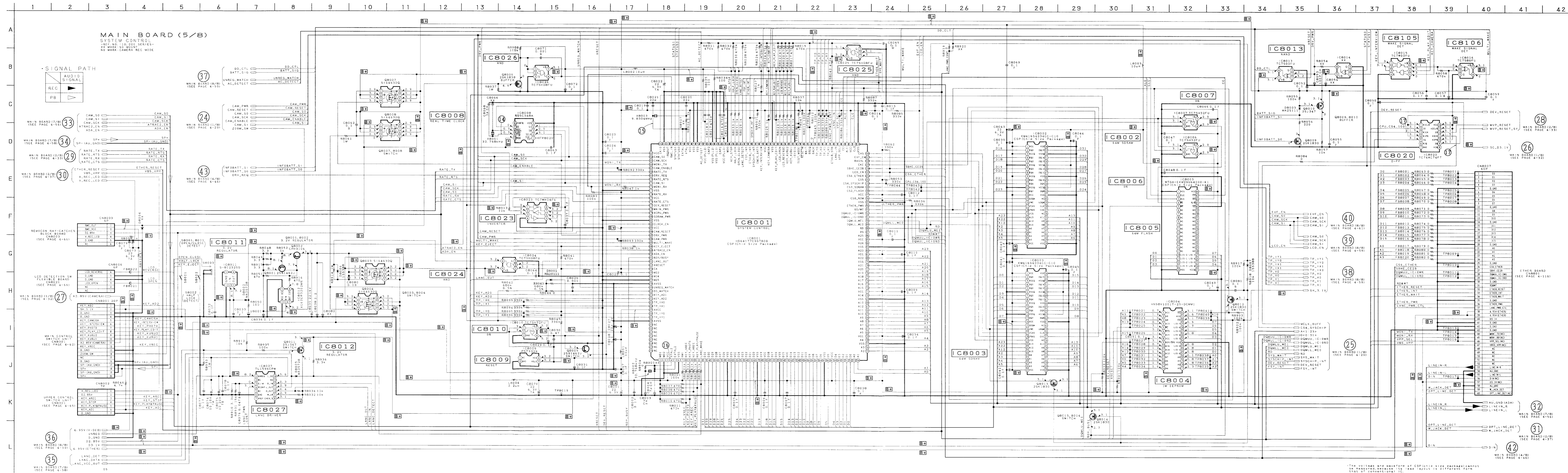

The package and waveforms of C8001 is different from that of conventional IC.

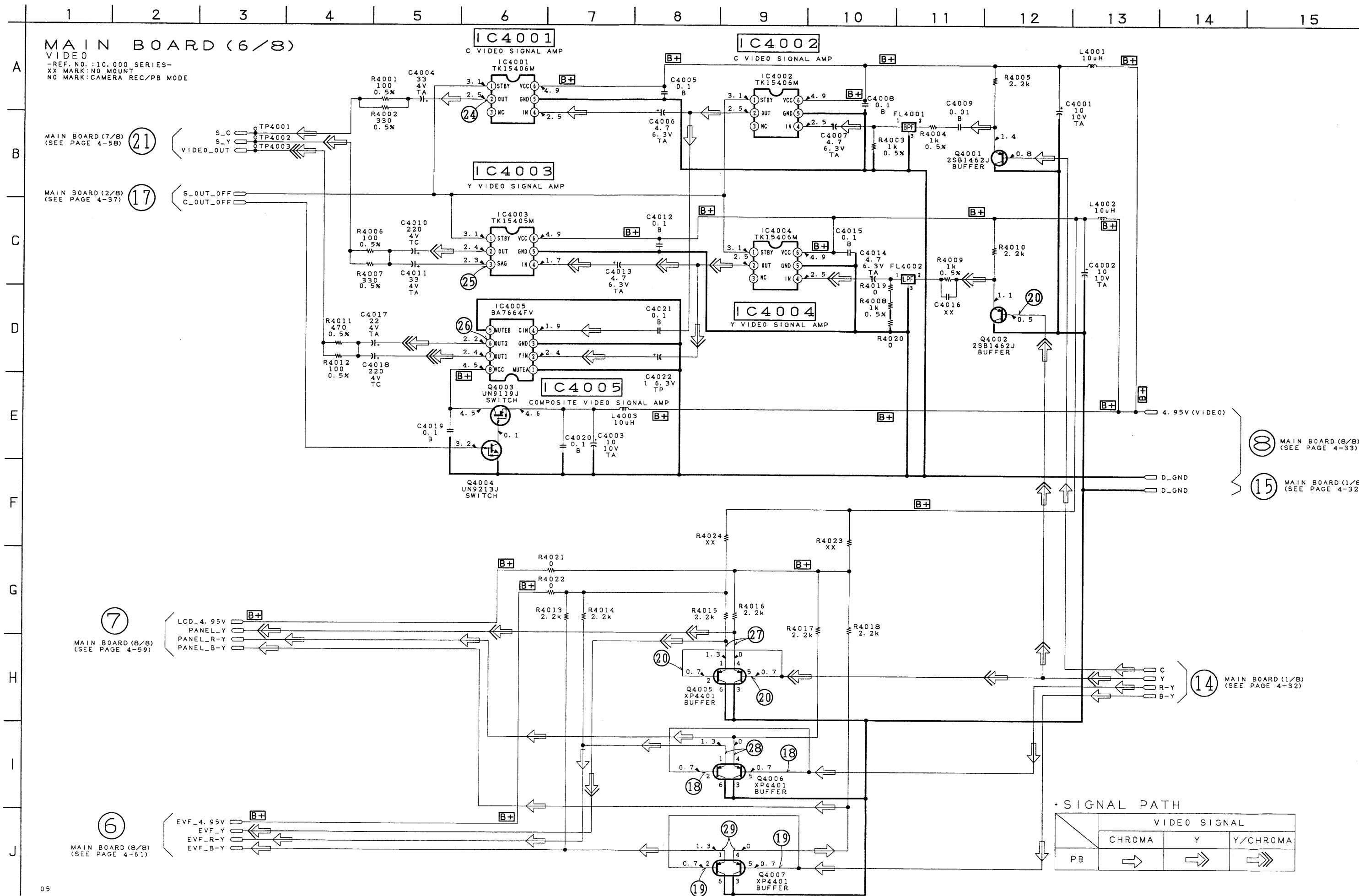

8 MAIN BOARD (8/8)  
(SEE PAGE 4-33)

15 MAIN BOARD (11/8)  
(SEE PAGE 4-32)

14 MAIN BOARD (1/8)  
(SEE PAGE 4-32)

7 MAIN BOARD (8/8)  
(SEE PAGE 4-59)

6 MAIN BOARD (8/8)  
(SEE PAGE 4-51)



MAIN BOARD (7/8)

AUDIO
-REF. NO.: 10,000 SERIES-
XX MARK: NO MOUNT
NO MARK: CAMERA REC/PB MODE
R: CAMERA REC MODE
P: PB MODE
) : MD1 PB MODE

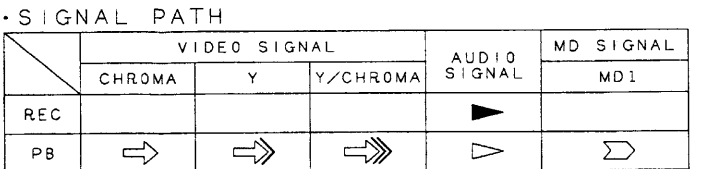
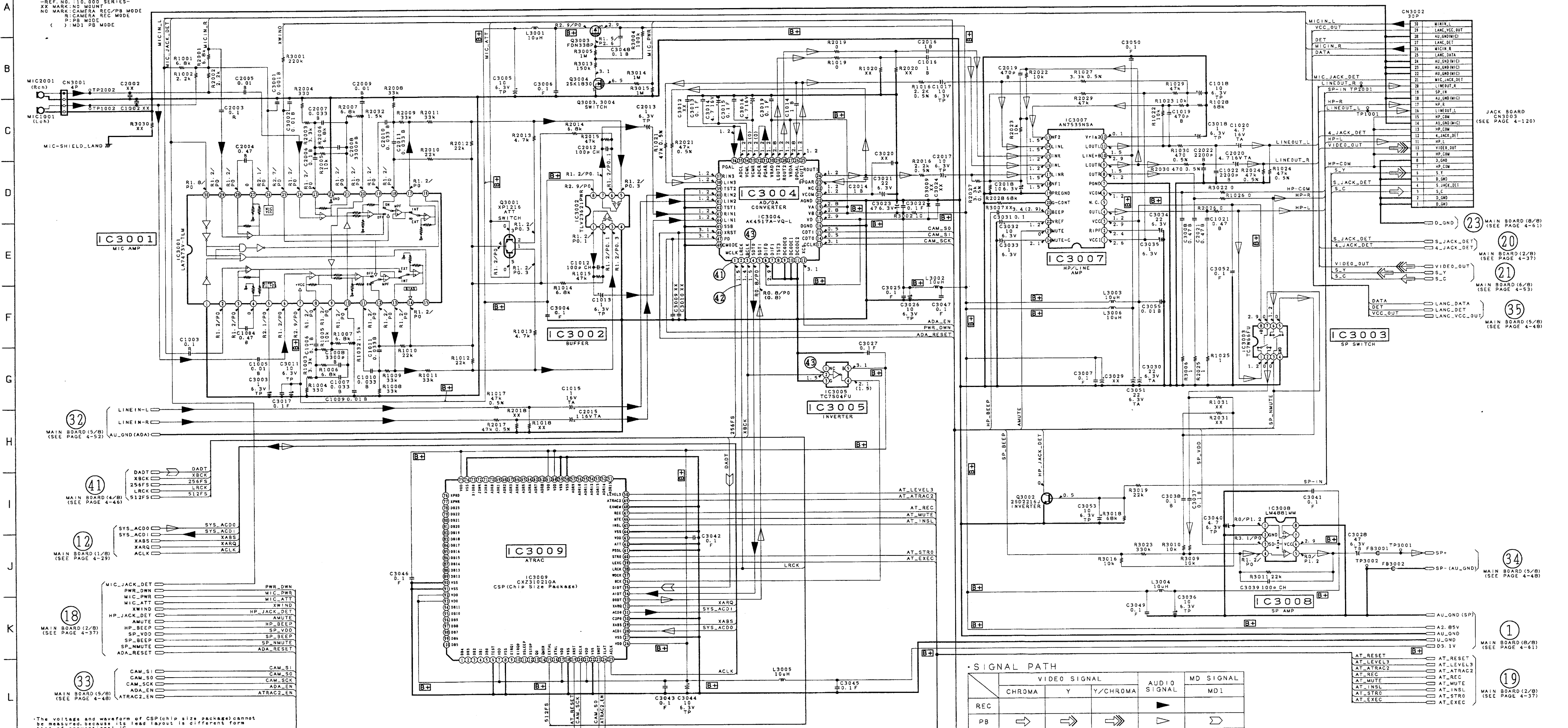

The voltage and waveform of CSP(chip size package) cannot be measured, because its lead layout is different form that of conventional IC.

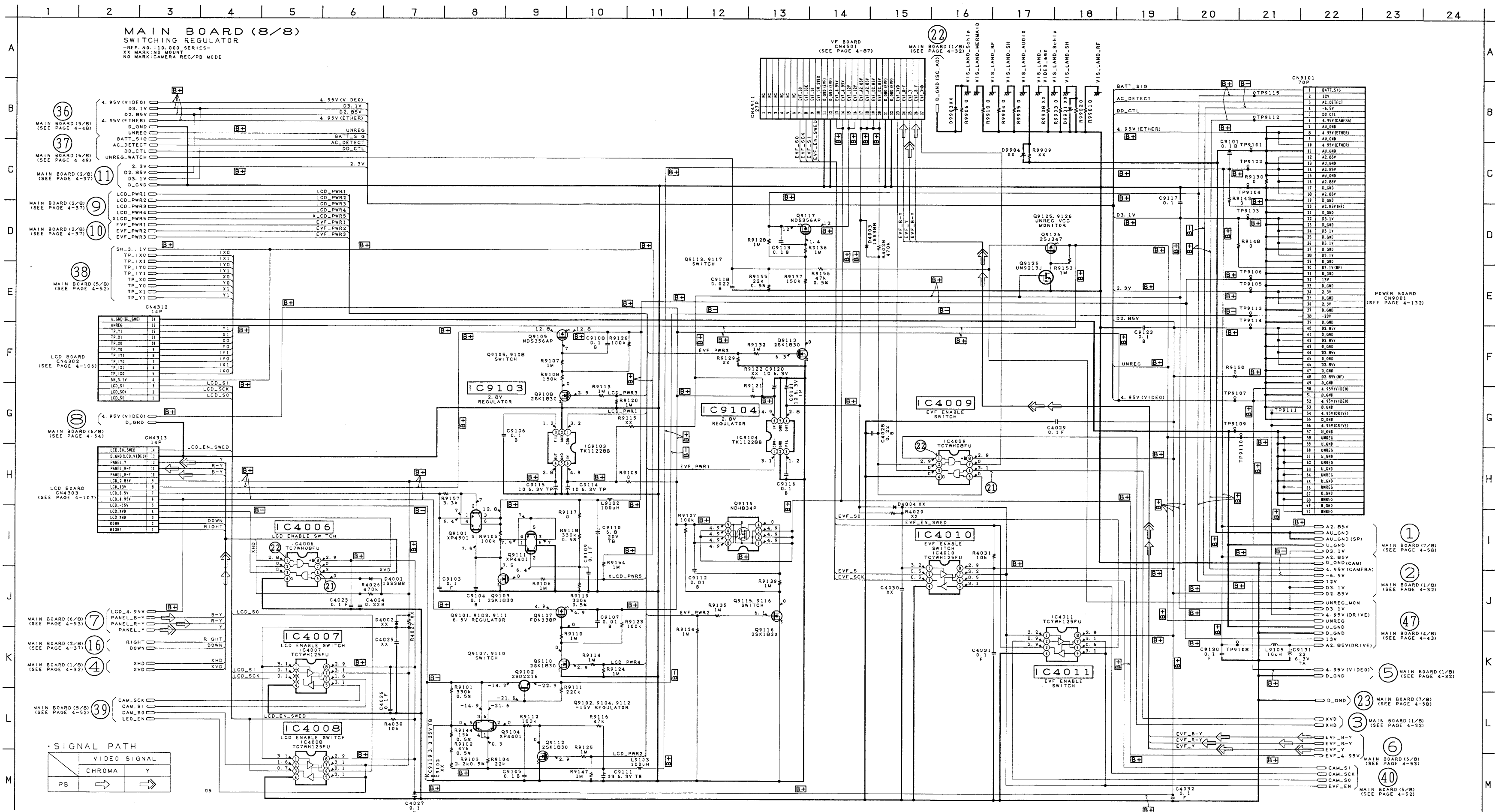

MAIN CONTROL SWITCH UNIT, ZOOM SWITCH UNIT SCHEMATIC DIAGRAM

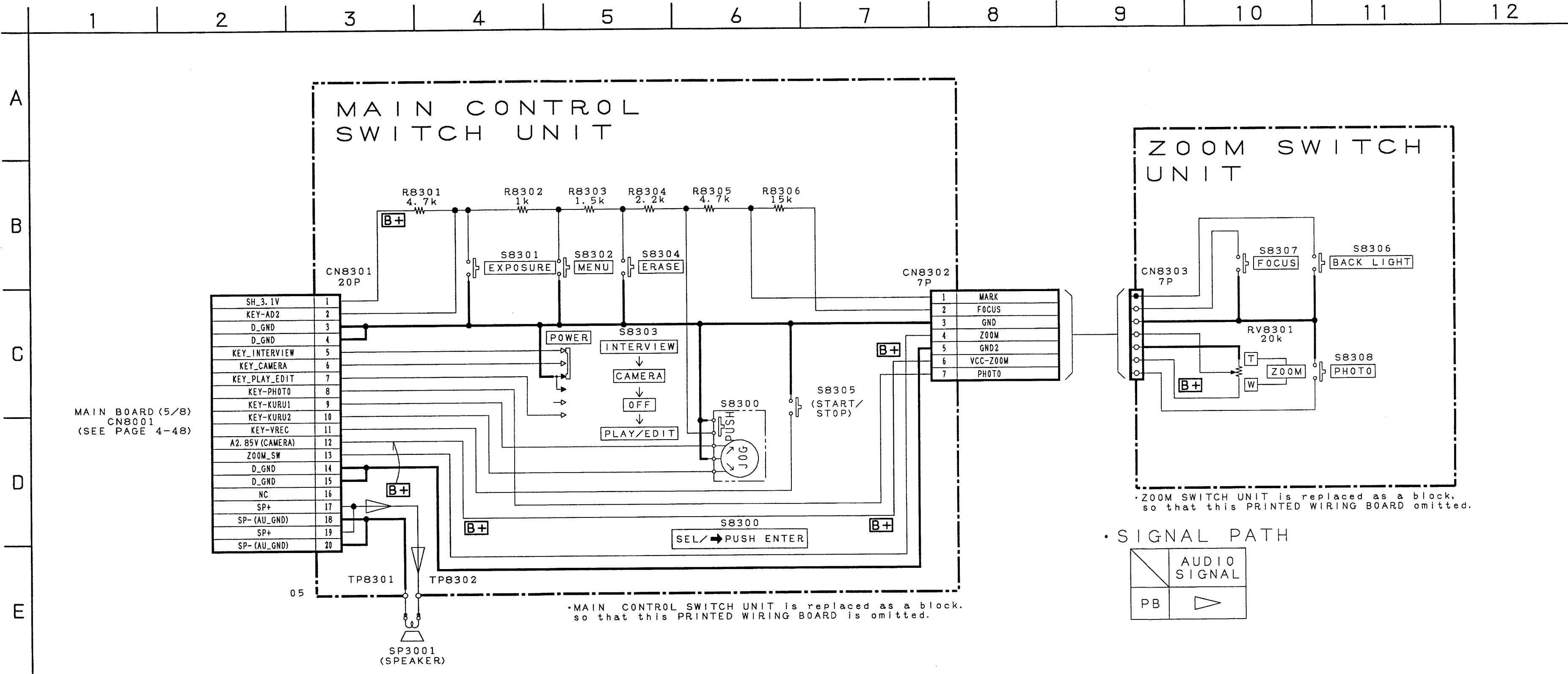

UPPER CONTROL SW SUB ASSY, REMOCON RAY-CATCHER BLOCK UNIT,  
LCD DETECTION SW FLEXIBLE BOARD SCHEMATIC DIAGRAM

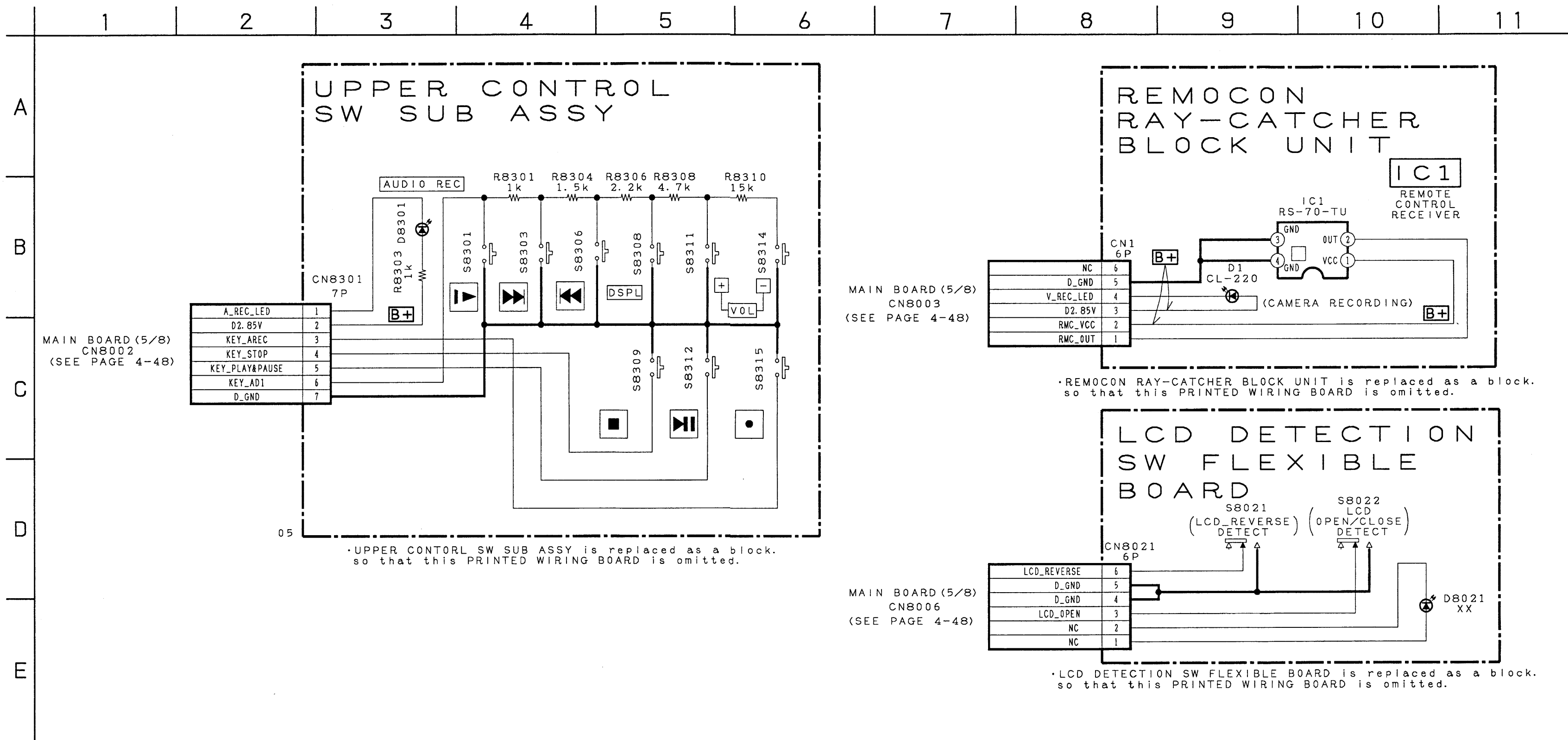

UPPER CONTROL SW SUB ASSY is replaced as a block.  
so that this PRINTED WIRING BOARD is omitted.

REMOCON RAY-CATCHER BLOCK UNIT is replaced as a block.  
so that this PRINTED WIRING BOARD is omitted.

LCD DETECTION SW FLEXIBLE BOARD is replaced as a block.  
so that this PRINTED WIRING BOARD is omitted.

CLV BOARD (SIDE A)

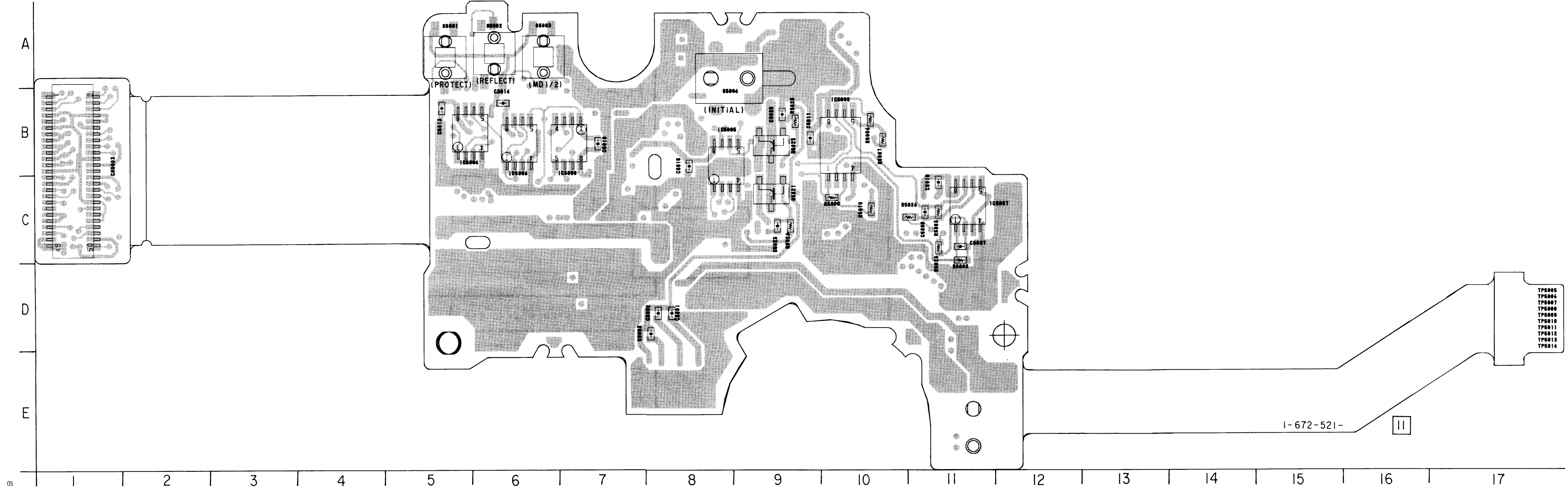

CLV BOARD (SIDE A)

C5807	C-11	R5802	C-11
C5808	C-11	R5803	C-11
C5811	B-9	R5806	B-10
C5813	B-5	R5807	B-10
C5814	A-6	R5809	C-10
C5815	B-8	R5810	C-10
C5818	B-7	R5823	C-11
C5819	B-11	R5824	C-11
C5823	C-9	R5826	C-9
C5825	B-9	R5828	B-9
IC5802	B-10	S5801	A-5
IC5804	B-6	S5802	A-6
IC5805	B-8	S5803	A-6
IC5806	B-6	S5804	A-9
IC5807	C-11		
IC5808	B-7		
Q5821	C-9		
Q5823	B-9		

- For Printed Wiring Board.
- There are few cases that the part isn't mounted in this model is printed on this diagram.
- Chip transistor

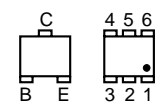

CLV BOARD (SIDE B)

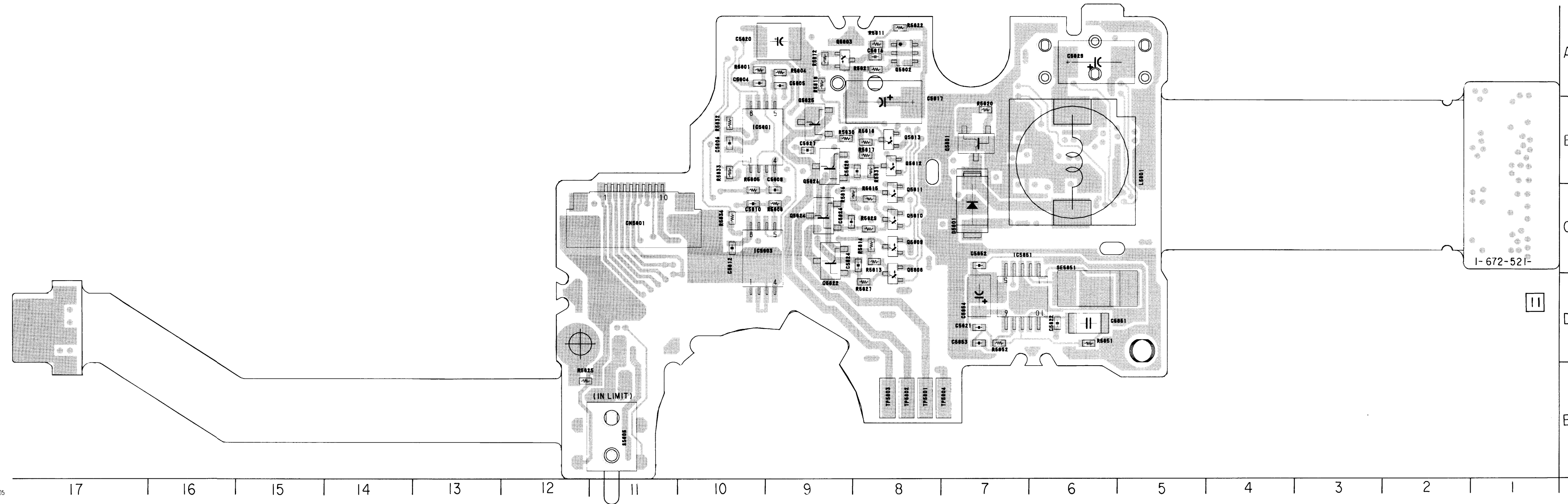
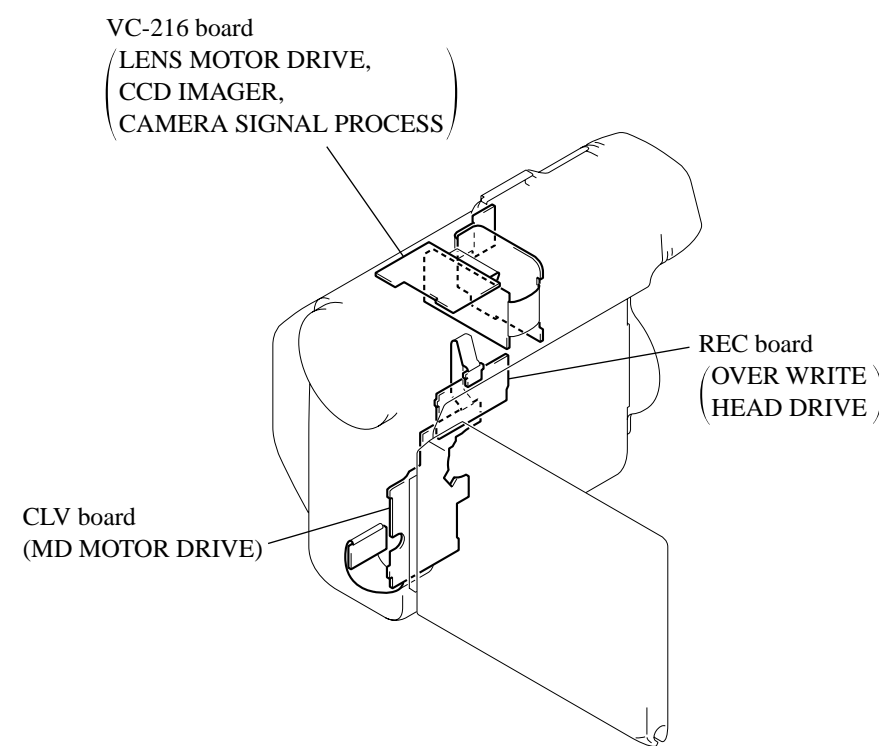

CLV BOARD (SIDE B)

C5804	A-10
C5805	A-9
C5806	B-10
C5809	C-9
C5810	C-10
C5812	C-10
C5816	A-8
C5817	B-8
C5820	A-9
C5824	C-8
C5826	C-9
C5827	B-9
C5828	B-9
C5829	A-6
C5851	D-6
C5852	C-7
C5853	D-7
C5854	D-7
CN5801	C-11
CN5803	B-1
D5801	C-7
IC5801	B-10
IC5802	C-10
IC5803	D-7
IC5851	D-7
L5801	B-6
Q5801	B-7
Q5802	A-8
Q5803	A-9
Q5808	D-8
Q5809	C-8
Q5810	C-8
Q5811	C-8
Q5812	B-8
Q5813	B-8
Q5822	C-9
Q5824	C-9
Q5825	B-9
Q5826	B-9
R5801	A-10
R5804	A-9
R5805	C-10
R5808	C-9
R5811	A-8
R5812	A-9
R5813	C-8
R5814	C-8
R5815	C-8
R5816	C-9
R5817	B-8
R5818	B-8
R5819	A-9
R5820	B-7
R5821	A-8
R5822	A-8
R5825	E-12
R5827	D-8
R5829	C-8
R5830	B-9
R5831	B-8
R5832	B-10
R5833	B-10
R5834	C-10
R5851	D-6
R5852	D-7
S5805	E-11
SE5851	D-6

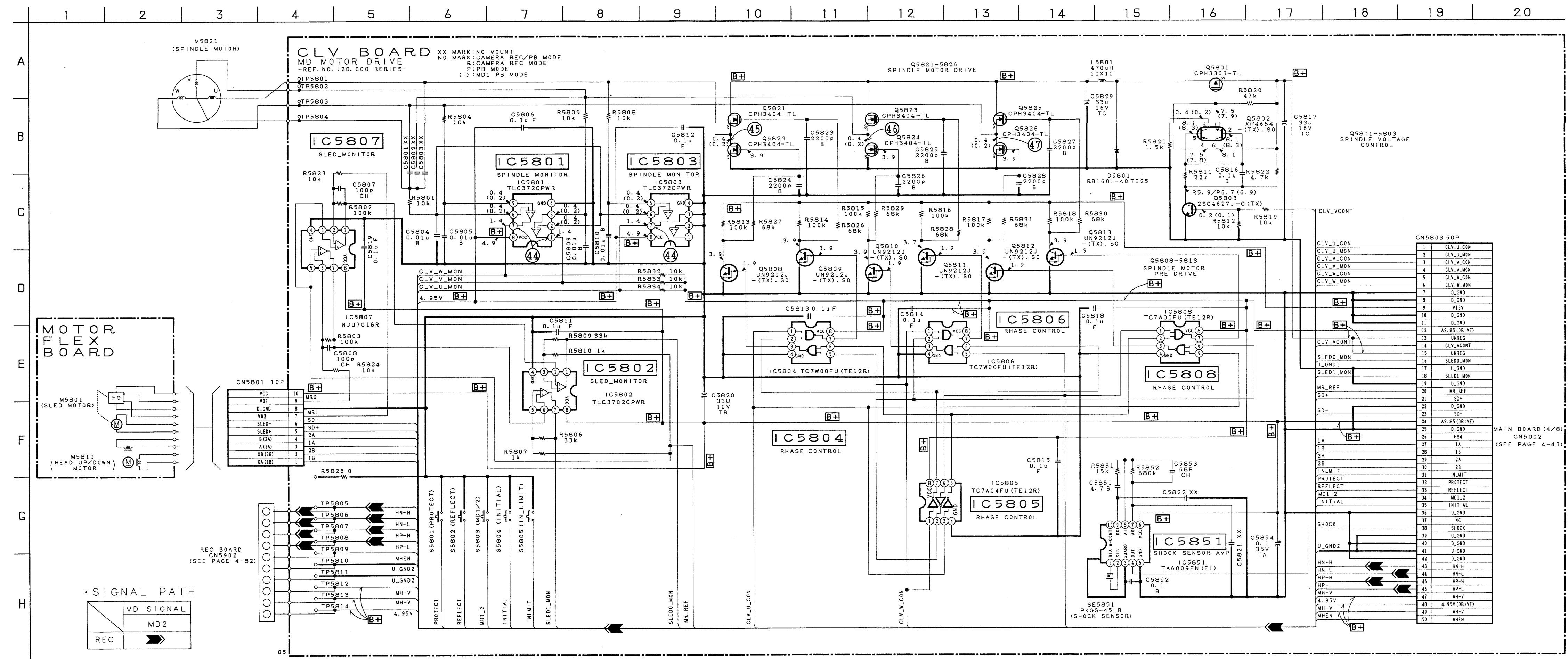

**REC (OVER WRITE HEAD DRIVE) PRINTED WIRING BOARD AND SCHEMATIC DIAGRAM**

- Ref. No.: REC board; 20,000 series -

- For Printed Wiring Board.
- There are few cases that the part isn't mounted in this model is printed on this diagram.
- Chip transistor

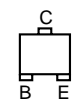

**REC BOARD (SIDE A)**

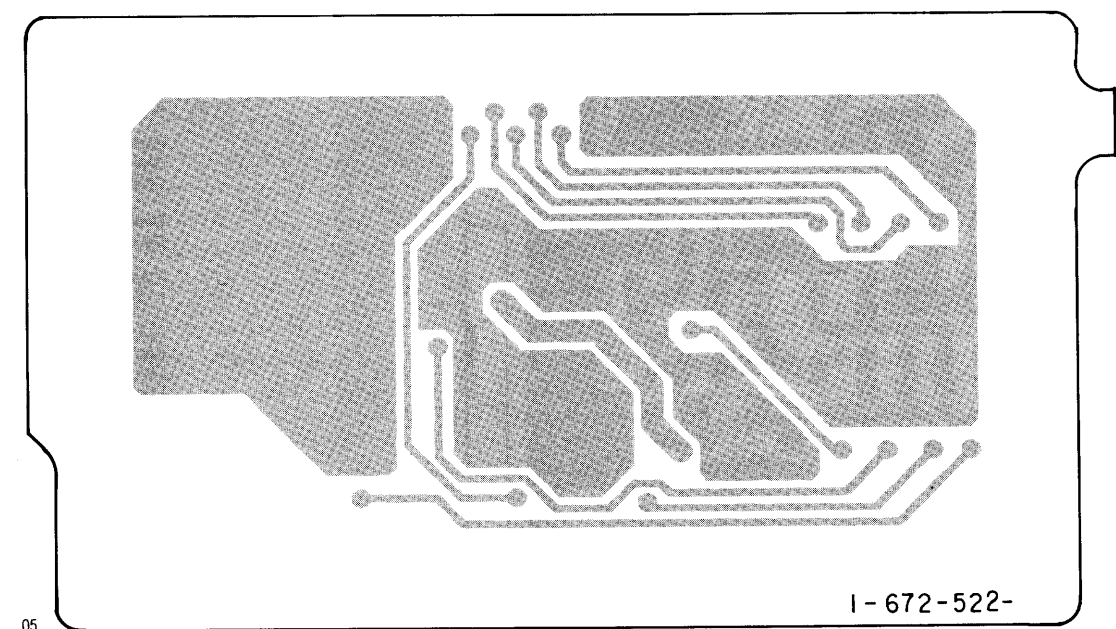

**REC BOARD (SIDE B)**

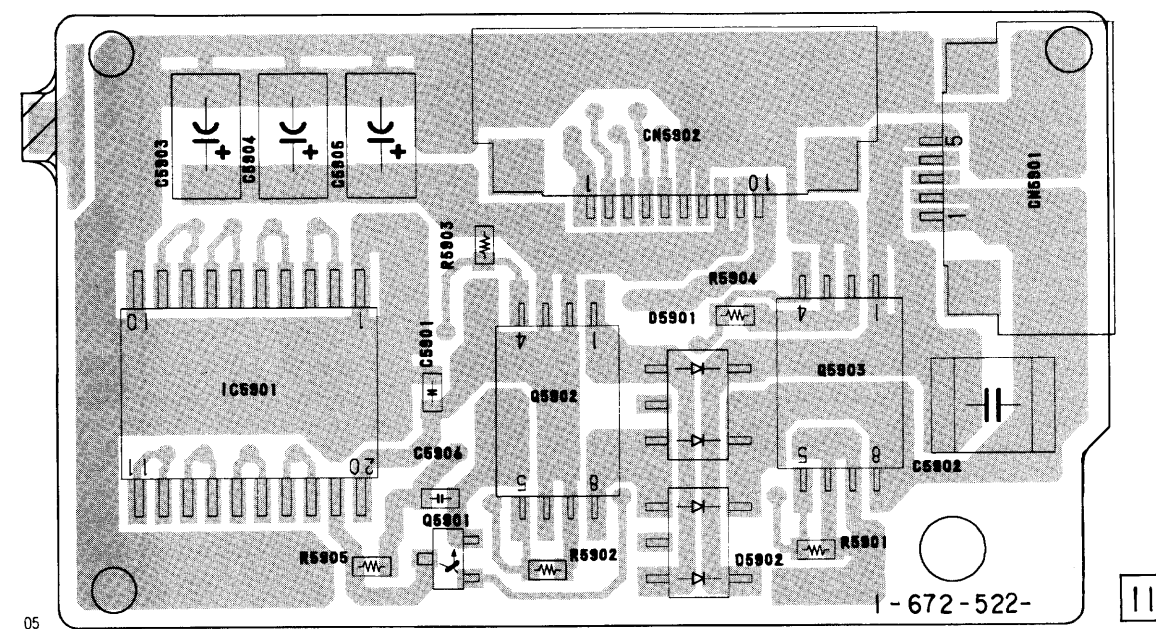

VC-216 board  
(LENS MOTOR DRIVE,  
CCD IMAGER,  
CAMERA SIGNAL PROCESS)

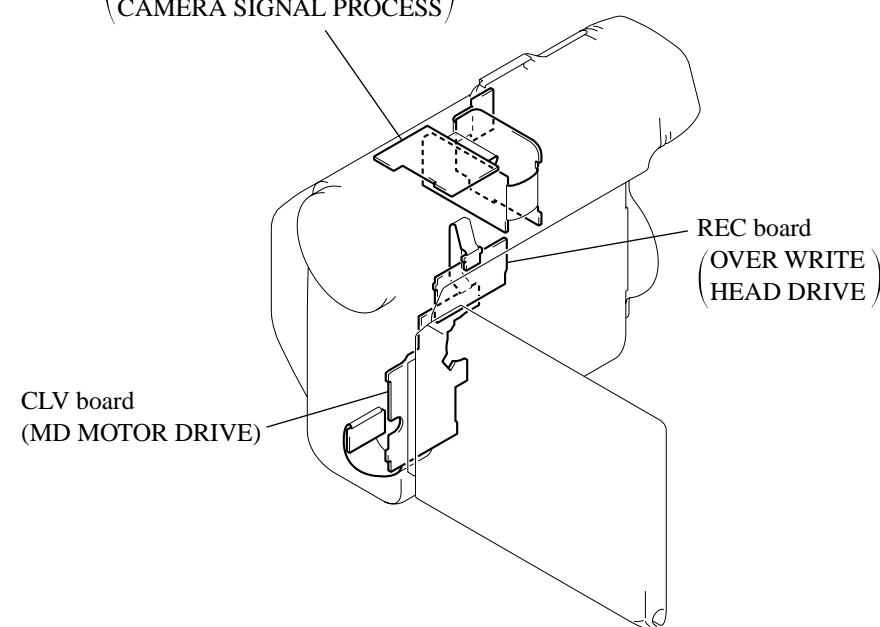

REC board  
(OVER WRITE  
HEAD DRIVE)

CLV board  
(MD MOTOR DRIVE)

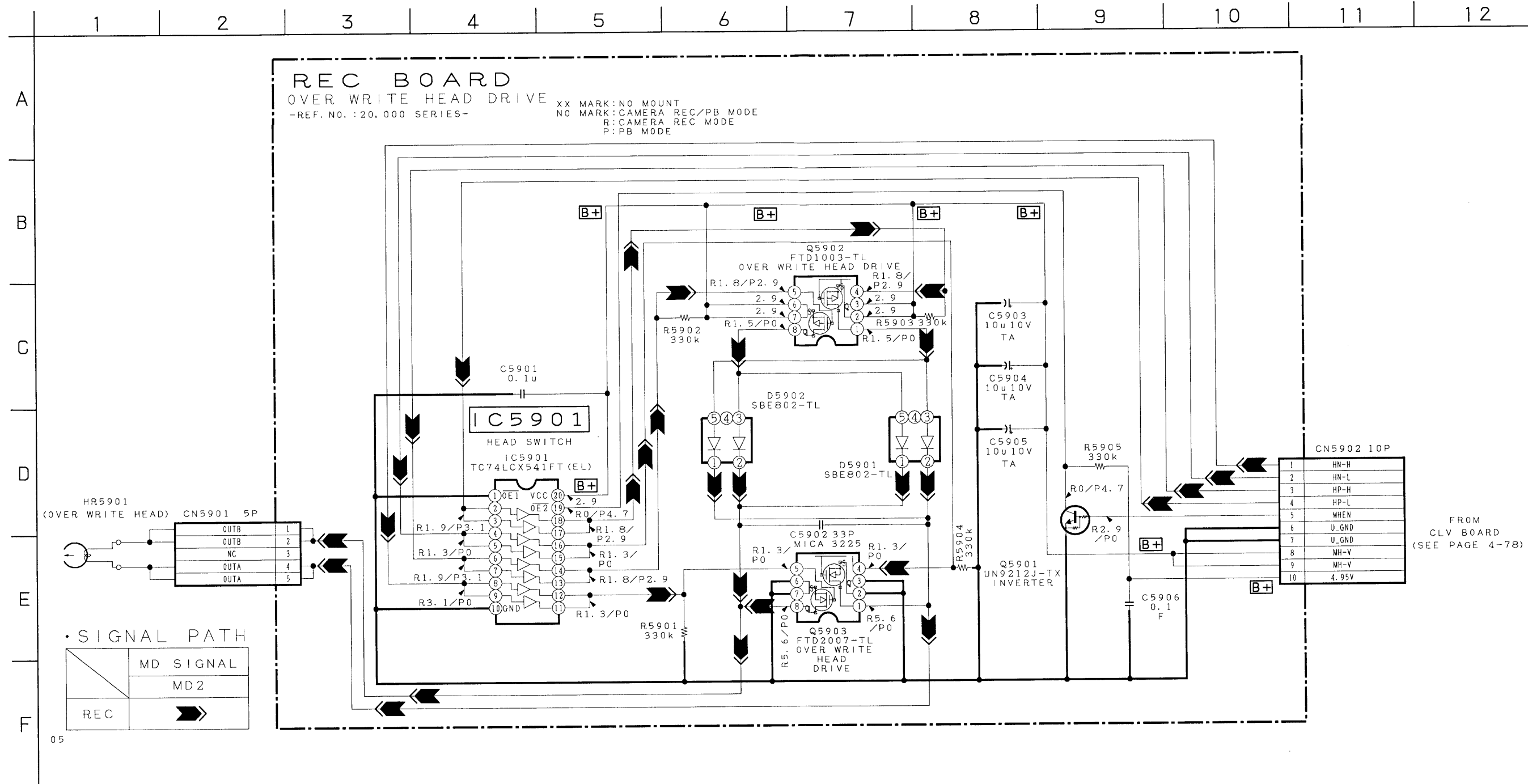



VF (EVF) PRINTED WIRING BOARD

- Ref. No.: VF board; 20,000 series -

VF BOARD (SIDE A)

VF BOARD (SIDE A)

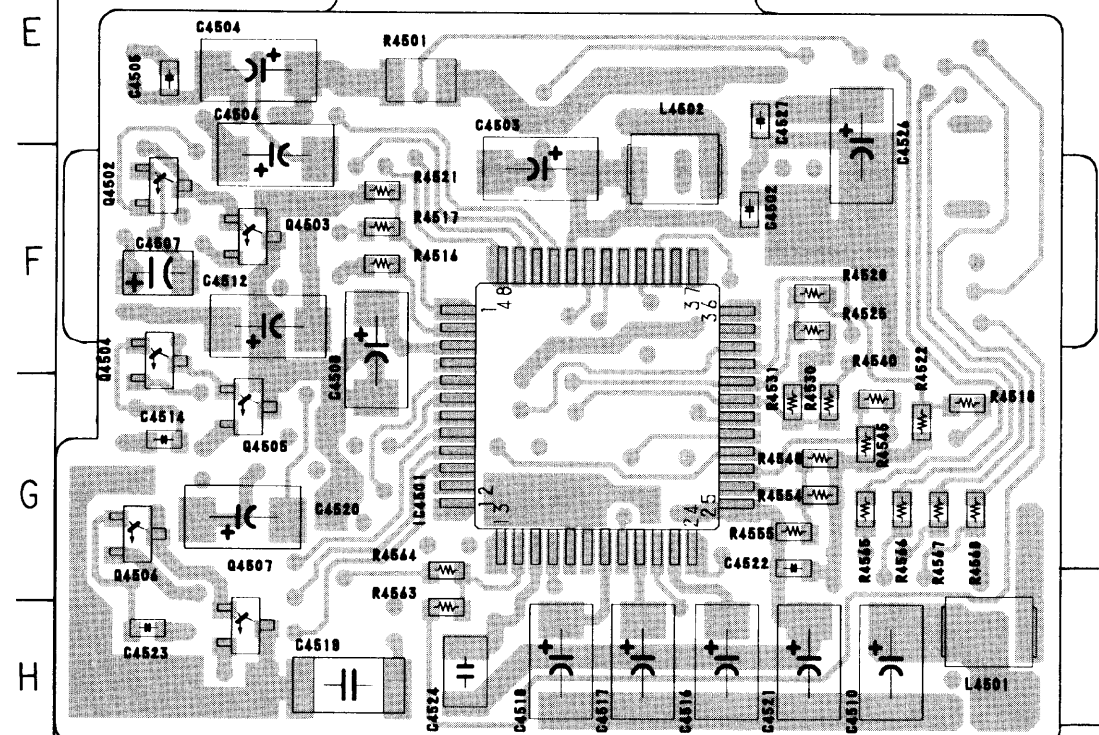
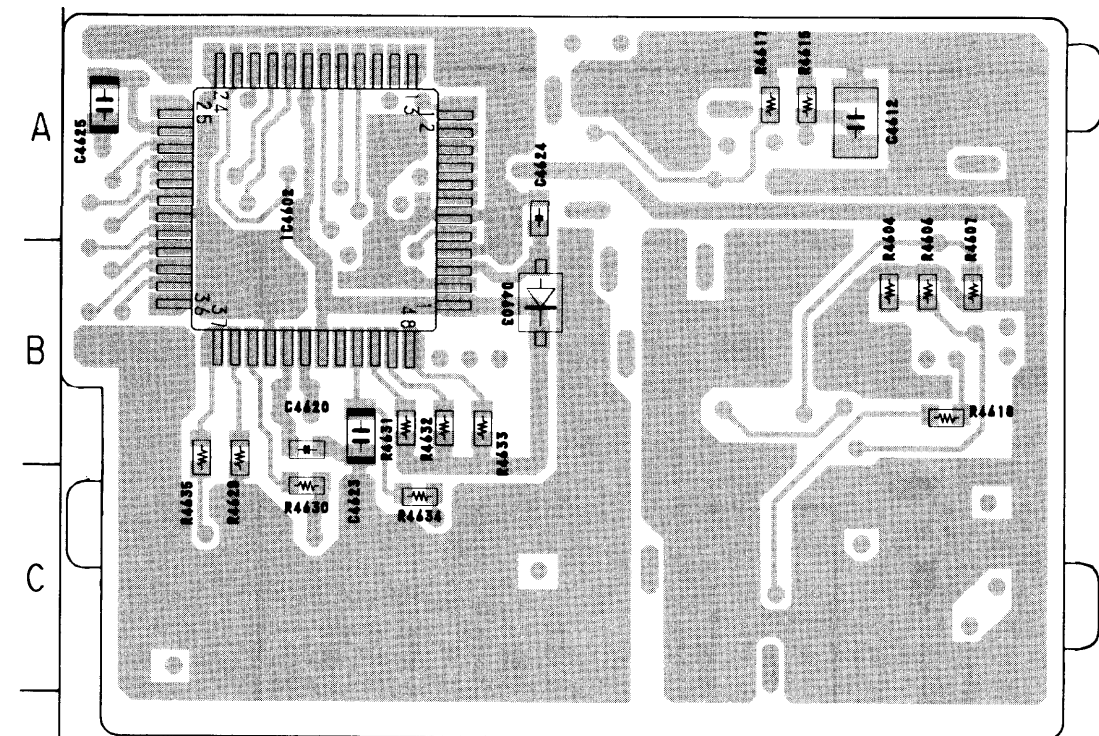

1 2 3 4 5 6 7 8

- For Printed Wiring Board.
- There are few cases that the part isn't mounted in this model is printed on this diagram.
- Chip transistor

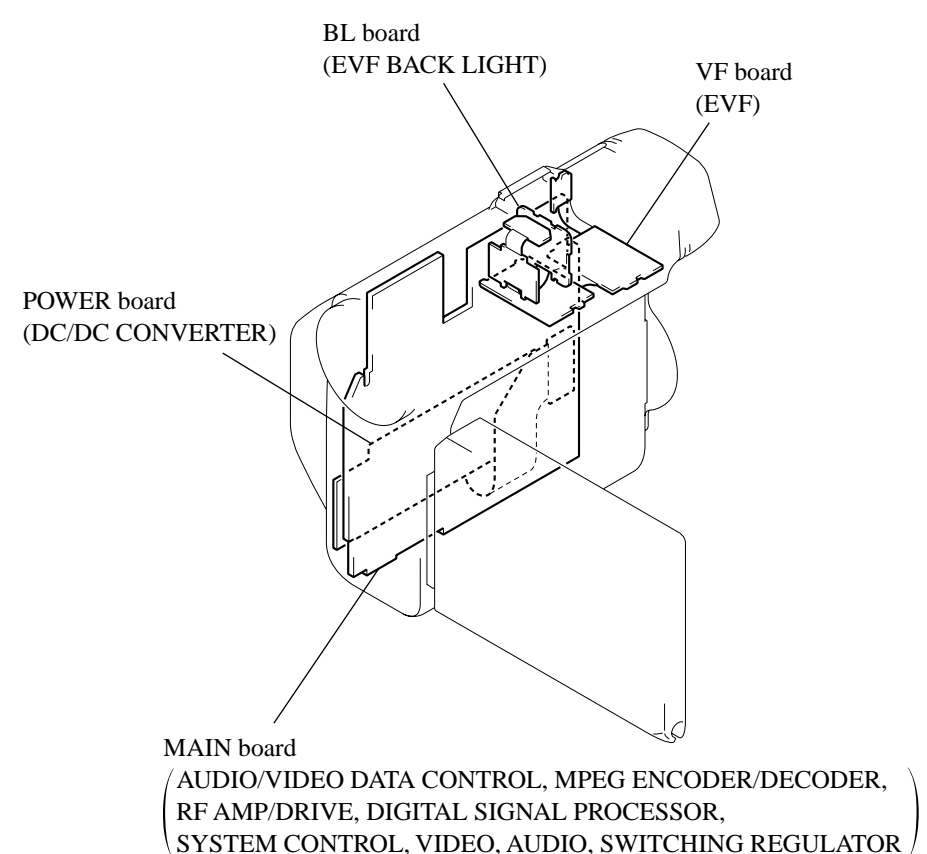

MAIN board  
(AUDIO/VIDEO DATA CONTROL, MPEG ENCODER/DECODER,  
RF AMP/DRIVE, DIGITAL SIGNAL PROCESSOR,  
SYSTEM CONTROL, VIDEO, AUDIO, SWITCHING REGULATOR)

EVF  
VF

VF BOARD (SIDE B)

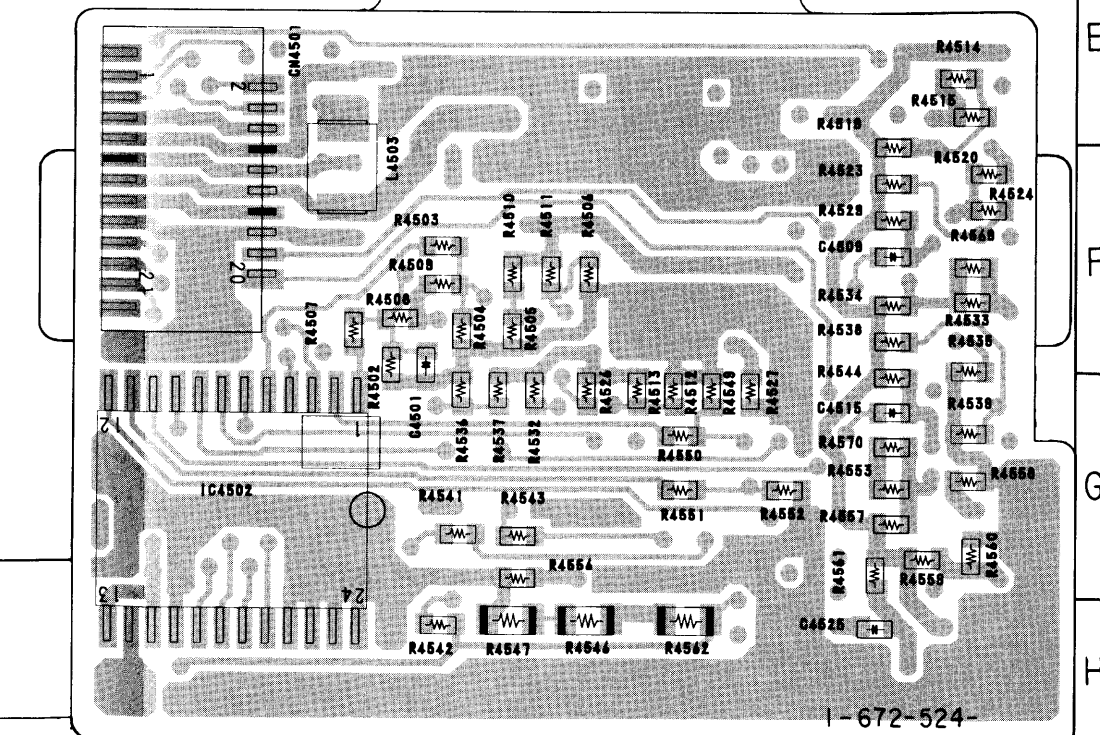
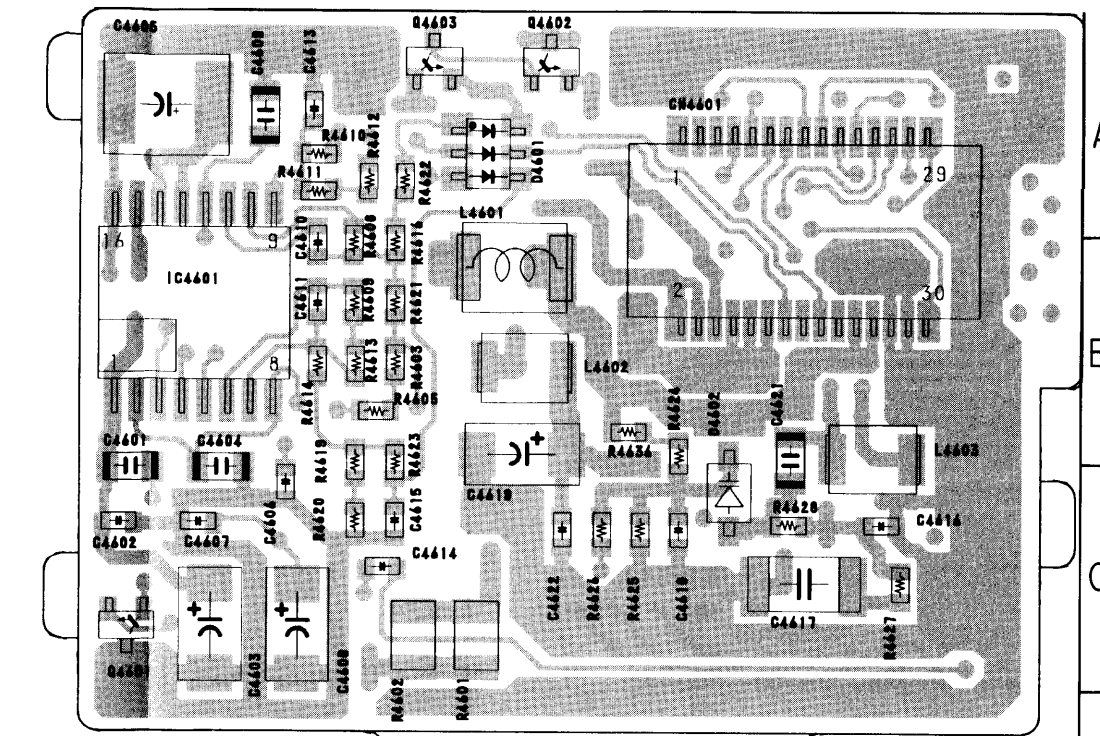

8 7 6 5 4 3 2 1

VF BOARD (SIDE B)

C4502	F-4
C4503	F-3
C4504	E-1
C4505	E-1
C4506	F-1
C4507	F-1
C4508	F-2
C4510	H-4
C4512	F-1
C4514	G-1
C4516	H-3
C4517	H-3
C4518	H-3
C4519	H-2
C4520	G-1
C4521	H-4
C4522	G-4
C4523	H-1
C4524	H-2
C4526	E-4
C4527	E-4
C4612	A-4
C4618	C-2
C4620	B-2
C4624	A-3
C4625	A-1
IC4501	G-3
IC4602	A-2
L4501	H-5
L4502	F-3
Q4502	F-1
Q4503	F-1
Q4504	F-1
Q4505	G-1
Q4506	G-1
Q4507	H-1
R4501	E-2
R4516	F-2
R4517	F-2
R4518	G-5
R4525	F-4
R4528	F-4
R4530	G-4
R4531	G-4
R4540	G-4
R4564	G-2
R4565	G-4
R4566	G-4
R4567	G-4
R4568	G-5
R4604	B-4
R4607	B-5
R4615	A-4
R4617	A-4
R4618	B-4
R4629	B-1
R4630	C-2
R4634	C-2
C4601	F-3
C4509	F-1
C4515	G-1
C4525	H-1
C4601	C-5
C4602	C-5
C4603	C-4
C4604	C-4
C4605	A-5
C4606	C-4
C4608	C-4
C4610	B-4
C4611	B-4
C4613	A-4
C4614	C-4
C4615	C-4
C4616	C-1
C4617	C-2
C4619	B-3
C4621	B-2
C4622	C-3
CN4501	F-4
CN4601	A-2
CN4901	H-7
D4601	A-3
D4602	C-2
IC4502	G-4
IC4601	B-4
L4503	F-4
L4601	B-3
L4602	B-3
L4603	B-1
Q4601	C-5
Q4602	A-3
Q4603	A-3
R4502	F-4
R4503	F-3
R4507	F-4
R4508	F-3
R4514	E-1
R4515	A-1
R4519	F-1
R4520	F-1
R4523	F-1
R4524	F-1
R4526	G-3
R4527	G-2
R4529	F-1
R4532	G-3
R4533	F-1
R4534	F-1
R4535	G-1
R4538	F-1
R4539	G-1
R4541	G-3
R4542	H-3
R4543	G-3
R4544	G-1
R4546	H-3
R4547	H-3
R4550	G-2
R4551	G-2
R4553	G-1
R4556	G-3
R4557	G-1
R4558	G-1
R4559	G-1
R4560	G-1
R4561	G-1
R4562	H-2
R4570	G-1
R4601	C-3
R4602	C-3
R4603	B-4
R4605	B-4
R4608	B-4
R4609	B-4
R4610	A-4
R4611	A-4
R4612	A-4
R4613	B-4
R4614	B-4
R4616	B-4
R4619	C-4
R4620	C-4
R4621	B-4
R4622	A-3
R4623	C-4
R4624	B-2
R4626	C-3
R4627	C-1
R4628	C-2
R4636	B-3

VF (EVF LCD DRIVE, EVF TIMING GENERATOR) SCHEMATIC DIAGRAM • See pages 4-133, 134, 135 for waveforms.

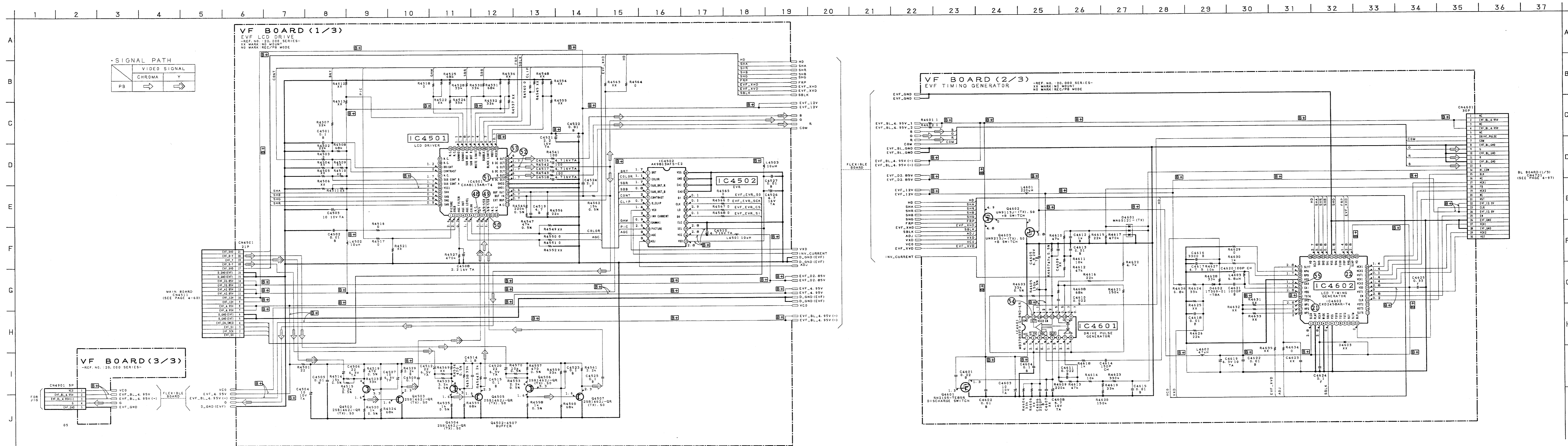

**BL (EVF BACK LIGHT) PRINTED WIRING BOARD**  
 - Ref. No.: BL board; 20,000 series -

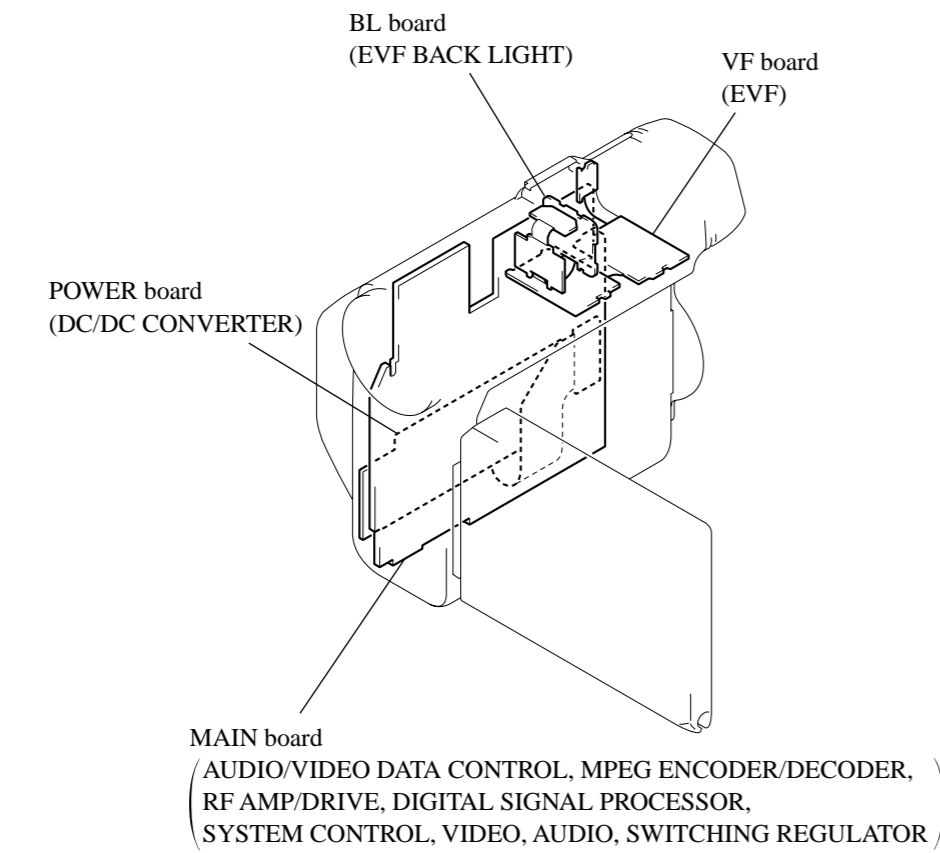

**BL BOARD (SIDE A)**

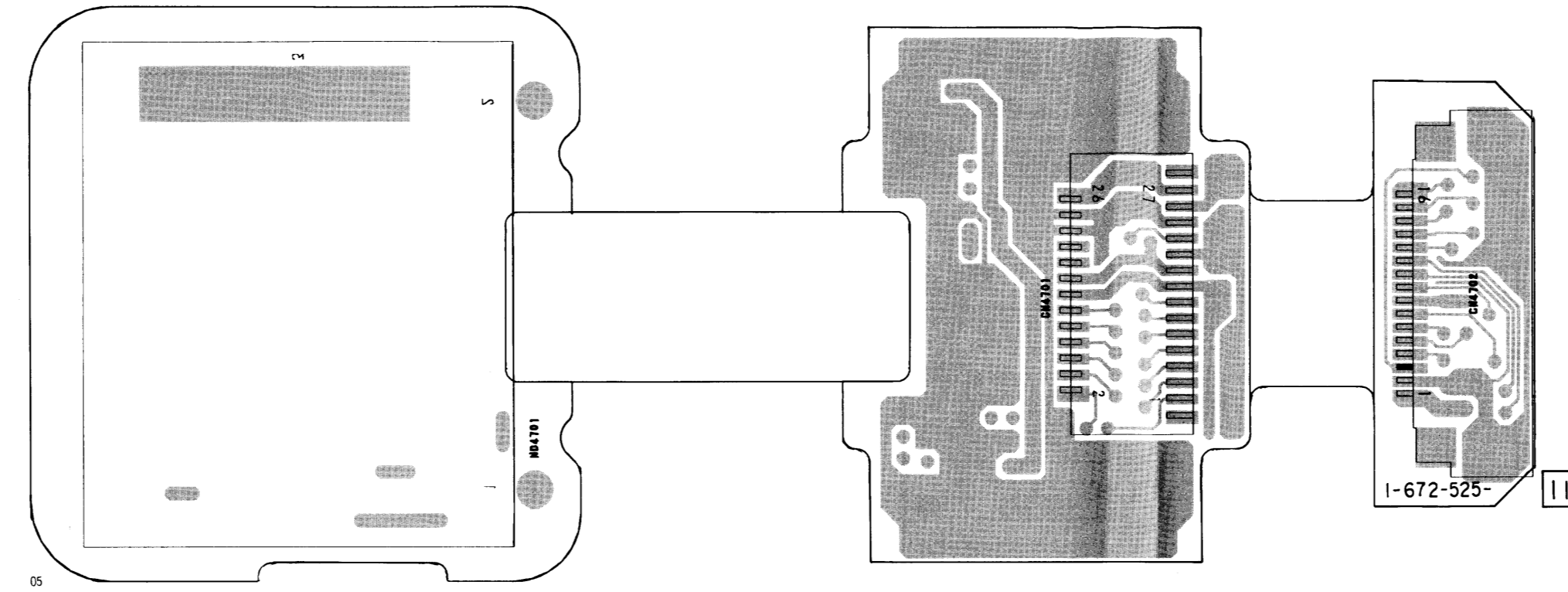

- For Printed Wiring Board.
- There are few cases that the part isn't mounted in this model is printed on this diagram.
- Chip transistor

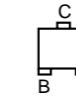

**BL BOARD (SIDE B)**

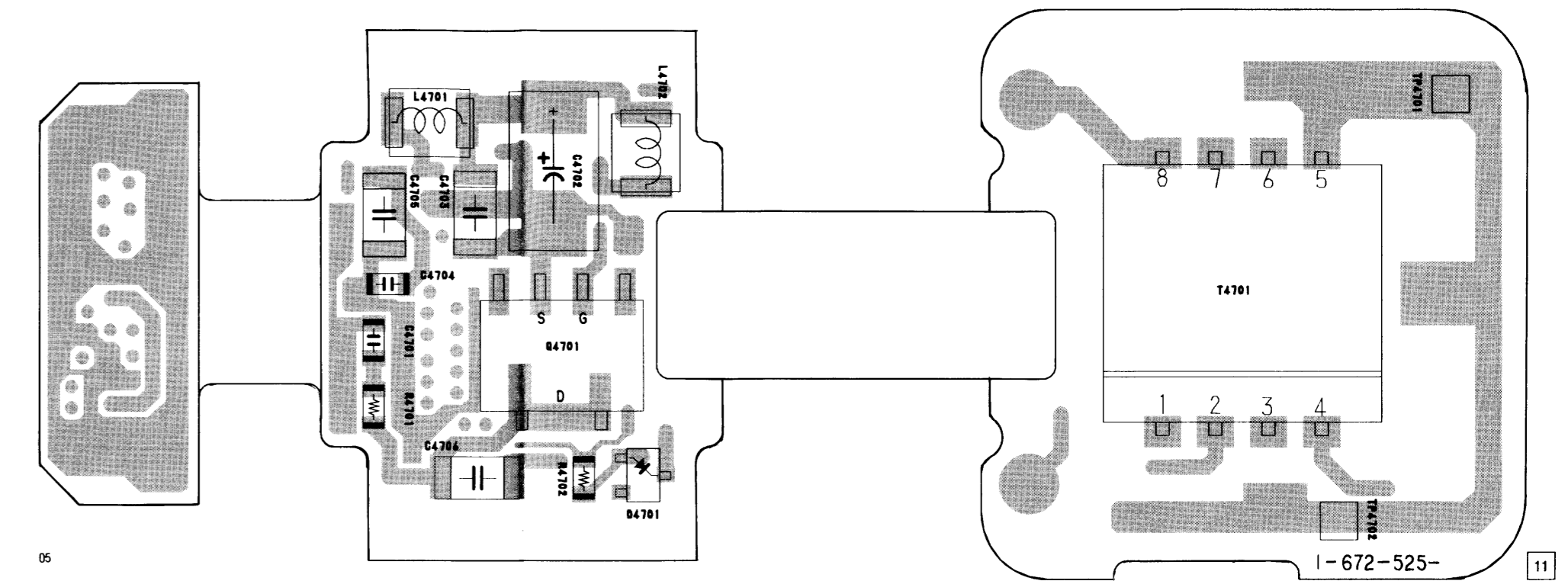

BL (EVF BACK LIGHT DRIVE, EVF BACK LIGHT) SCHEMATIC DIAGRAM

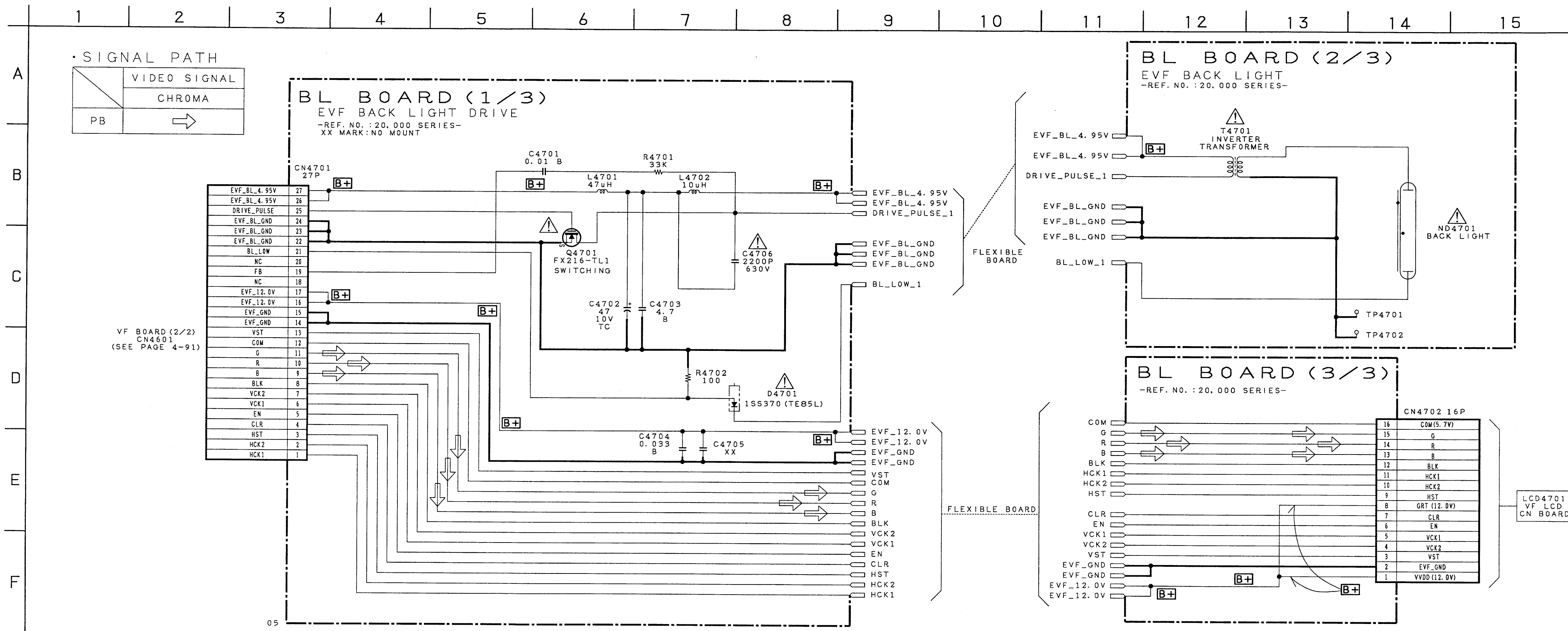

**Note:**  
The components identified by mark  $\Delta$  or dotted line with mark  $\Delta$  are critical for safety. Replace only with part number specified.

**Note:**  
Les composants identifiés par une marque  $\Delta$  sont critiques pour la sécurité. Ne les remplacer que par une pièce portant le numéro spécifié.

LCD (LCD) PRINTED WIRING BOARD  
- Ref. No.: LCD board; 20,000 series -

LCD BOARD (SIDE A)

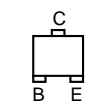
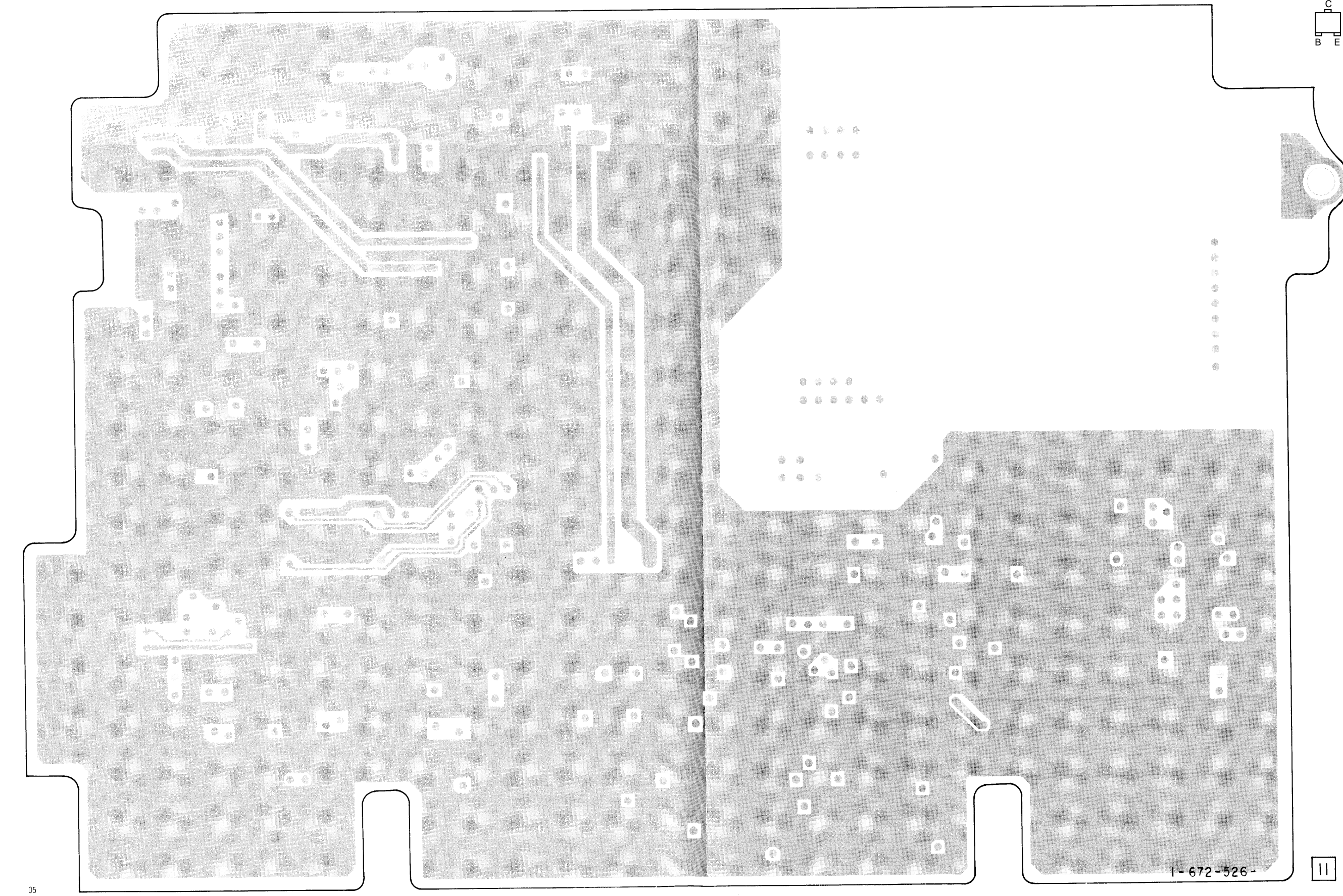

- For Printed Wiring Board.
- There are few cases that the part isn't mounted in this model is printed on this diagram.
- Chip transistor

LCD BOARD (SIDE B)

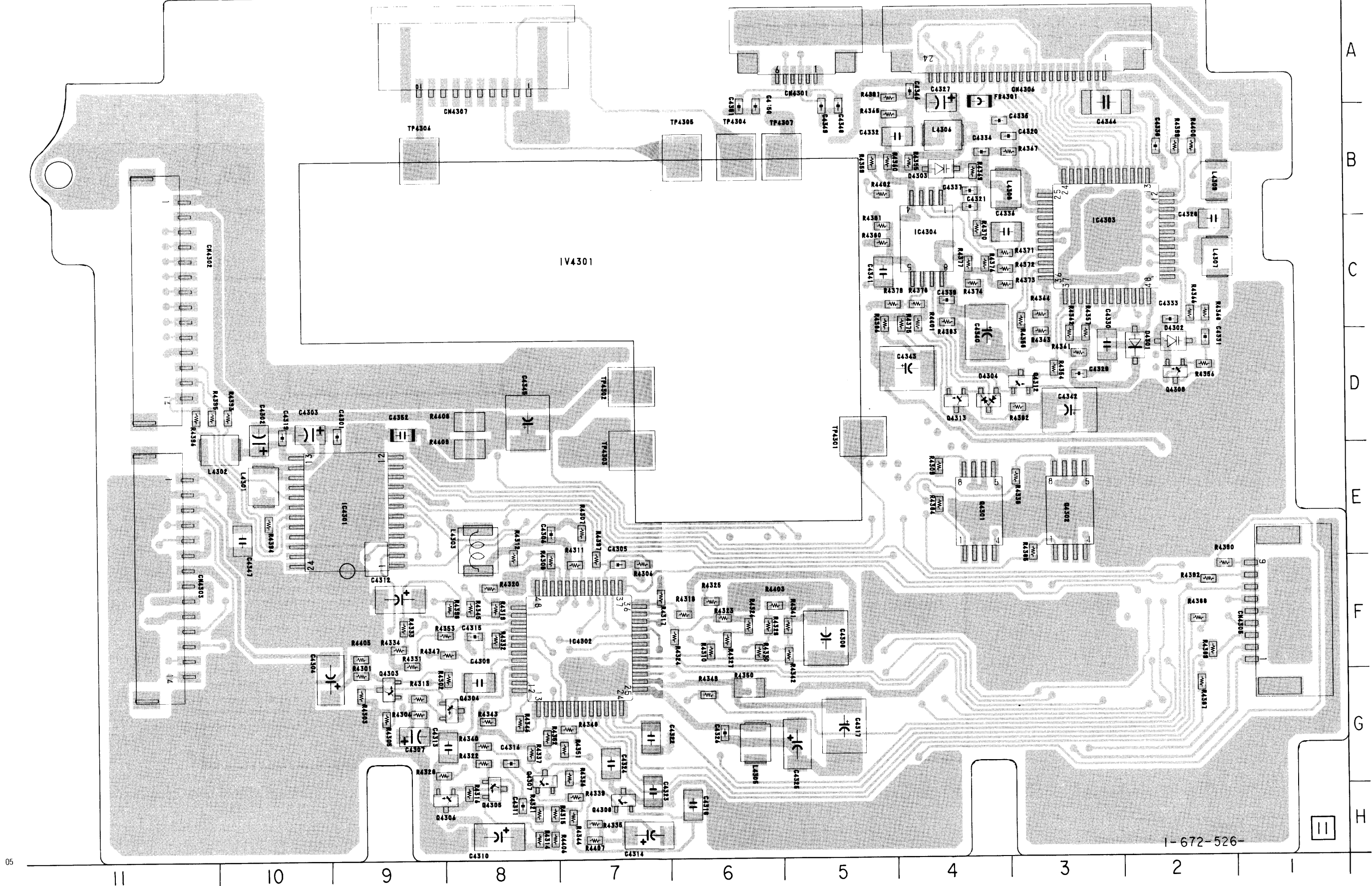

A  
B  
C  
D  
E  
F  
G  
H

LCD BOARD (SIDE B)

C4301	D-9	FB4301	A-4	R4337	G-8
C4302	D-10			R4338	E-3
C4303	D-10	IC4301	E-9	R4339	H-7
C4304	G-10	IC4302	F-7	R4340	G-8
C4305	F-7	IC4303	C-3	R4343	G-8
C4306	E-8	IC4304	C-4	R4344	H-7
C4307	G-9			R4345	F-8
C4308	F-5	L4301	E-10	R4347	F-8
C4309	G-8	L4302	E-10	R4350	G-6
C4310	H-8	L4303	E-8	R4351	G-7
C4311	H-8	L4305	G-6	R4353	F-8
C4312	F-9	L4306	B-4	R4354	D-3
C4313	G-8	L4307	C-2	R4356	D-2
C4314	H-7	L4308	B-3	R4357	D-3
C4315	F-8	L4309	B-2	R4358	C-3
C4316	G-8			R4359	B-5
C4317	G-5	Q4301	E-4	R4360	B-5
C4318	H-6	Q4302	E-3	R4362	D-3
C4319	D-10	Q4303	G-9	R4366	C-2
C4320	B-3	Q4304	G-8	R4369	B-4
C4321	B-4	Q4305	H-8	R4370	C-4
C4322	G-7	Q4306	H-8	R4371	C-4
C4323	H-7	Q4307	G-8	R4372	C-4
C4324	G-7	Q4308	H-7	R4373	C-4
C4325	G-5	Q4312	D-3	R4374	C-4
C4326	G-6	Q4313	D-4	R4375	C-4
C4327	A-4			R4376	C-4
C4328	C-2	R4301	F-9	R4377	C-4
C4329	D-3	R4302	G-8	R4378	C-4
C4330	D-3	R4303	G-9	R4379	C-5
C4331	D-2	R4304	G-9	R4380	C-5
C4332	B-4	R4305	G-9	R4381	C-5
C4334	B-4	R4309	E-4	R4392	D-3
C4335	B-4	R4310	F-6	R4393	C-4
C4336	C-3	R4313	G-9	R4394	E-4
C4337	B-4	R4314	H-8	R4385	E-3
C4338	B-2	R4315	H-8	R4386	C-5
C4339	C-4	R4316	H-8	R4387	G-2
C4340	D-4	R4317	F-7	R4388	F-2
C4341	C-5	R4318	F-6	R4389	F-2
C4342	D-3	R4319	F-8	R4390	F-2
C4344	A-3	R4320	F-8	R4391	A-5
C4345	D-8	R4321	H-8	R4392	F-2
C4346	A-4	R4322	G-8	R4393	D-10
C4352	D-9	R4323	F-6	R4394	E-10
		R4324	F-6	R4395	D-11
CN4301	A-5	R4325	F-6	R4396	D-11
CN4302	C-11	R4326	F-6	R4397	E-7
CN4303	F-11	R4327	F-6	R4400	B-2
CN4305	F-1	R4328	G-9	R4401	C-4
CN4306	A-3	R4329	F-6	R4402	B-5
CN4307	A-8	R4330	F-6	R4403	F-6
		R4331	F-9	R4405	F-9
D4302	D-2	R4334	F-9	R4407	H-7
D4303	B-4	R4335	H-7	R4408	D-8
D4304	D-4	R4336	G-7	R4409	E-8

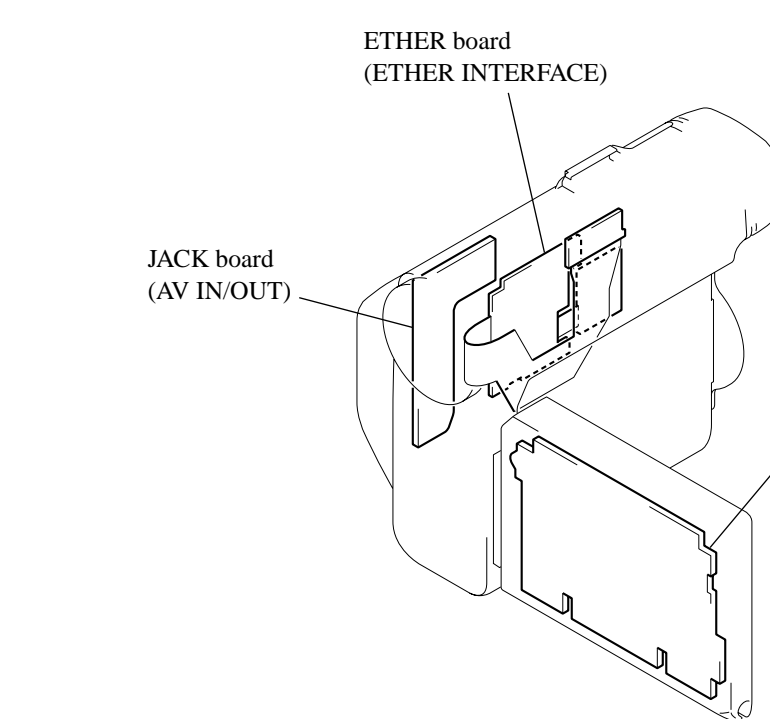

**Note:**  
The components identified by mark  $\Delta$  or dotted line with mark  $\Delta$  are critical for safety. Replace only with part number specified.

**Note:**  
Les composants identifiés par une marque  $\Delta$  sont critiques pour la sécurité. Ne les remplacer que par une pièce portant le numéro spécifié.

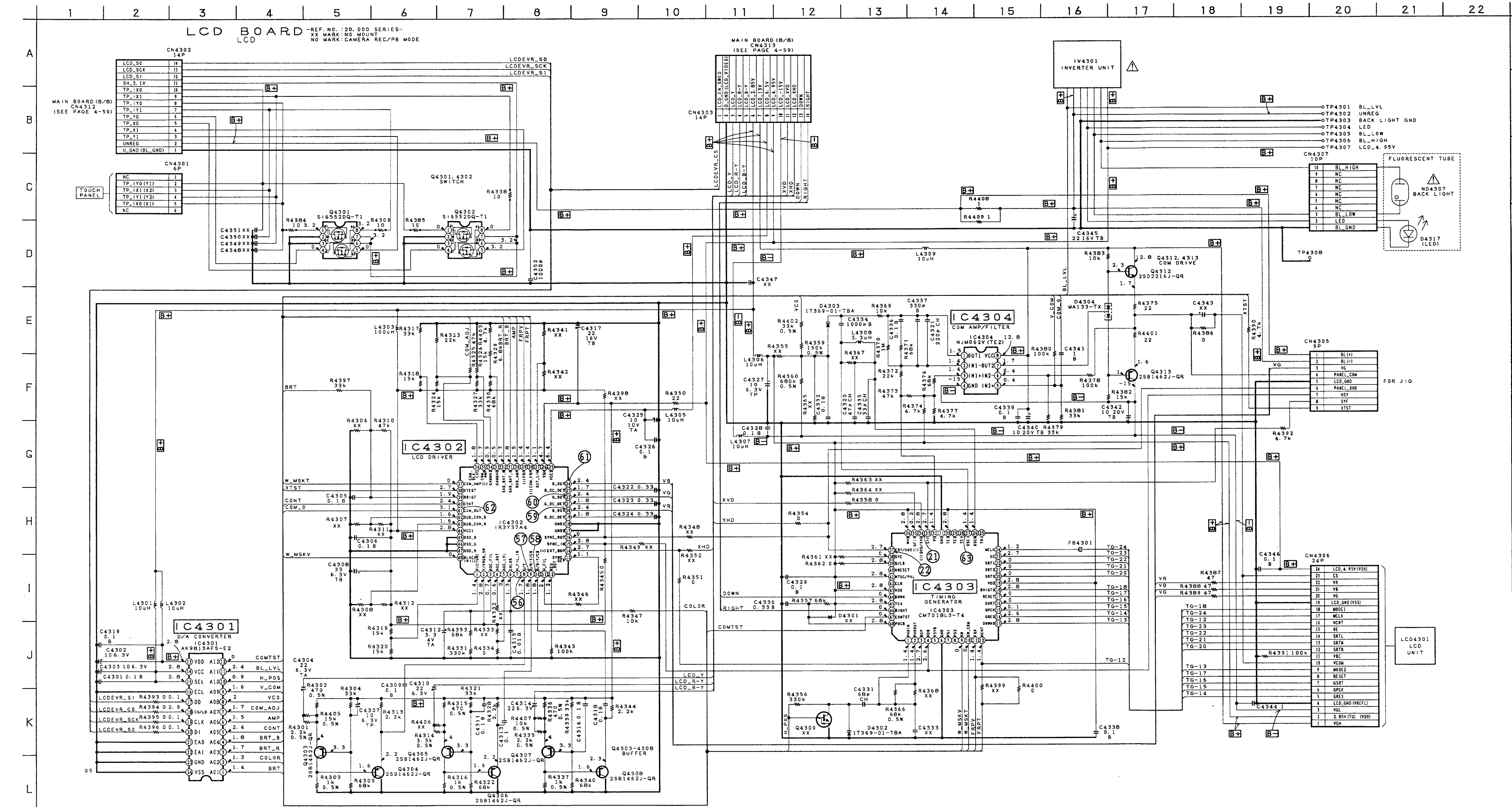

ETHER (ETHER INTERFACE) PRINTED WIRING BOARD  
- Ref. No.: ETHER board; 20,000 series -

ETHER BOARD (SIDE A)

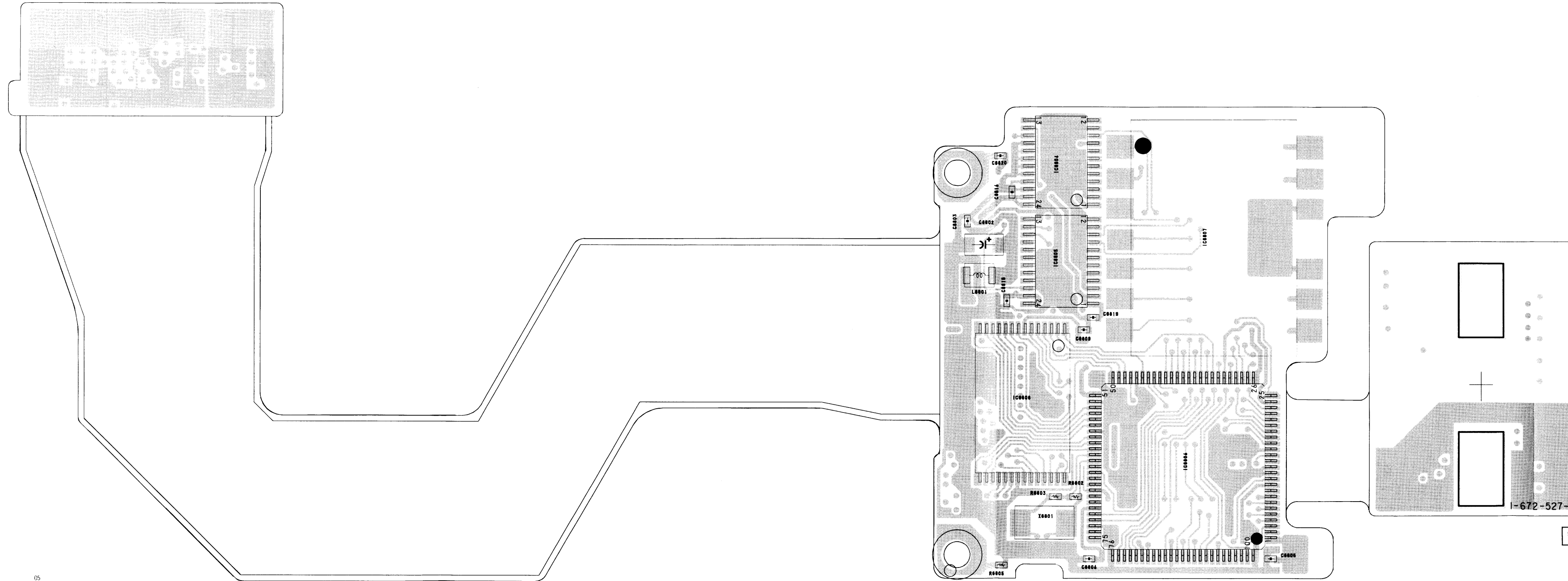

- For Printed Wiring Board.
- There are few cases that the part isn't mounted in this model is printed on this diagram.
- Chip transistor

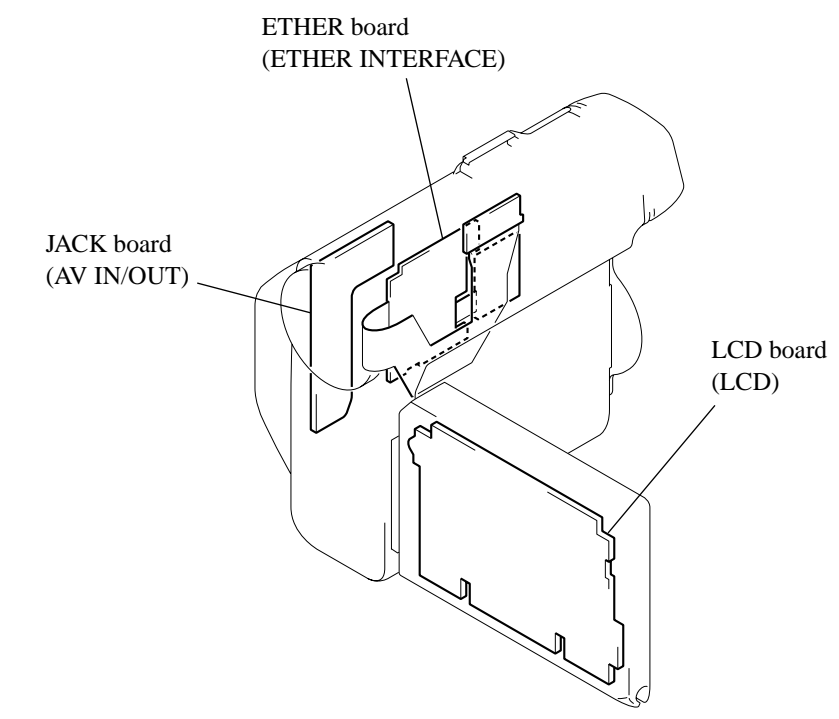
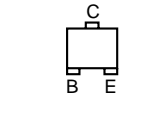

05

ETHER BOARD (SIDE B)

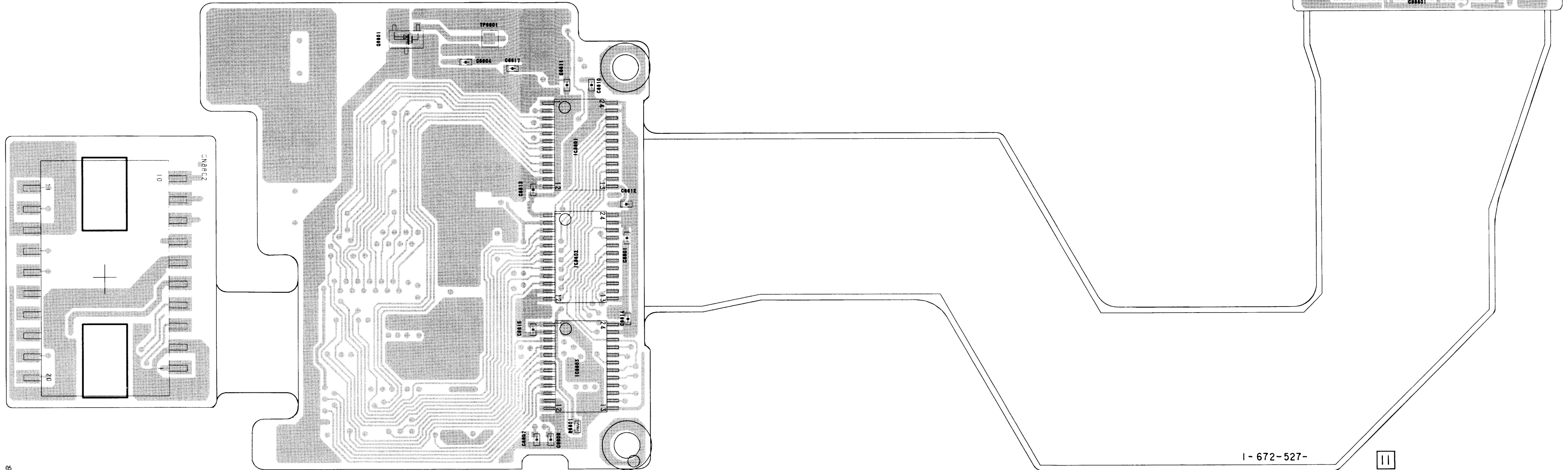

05



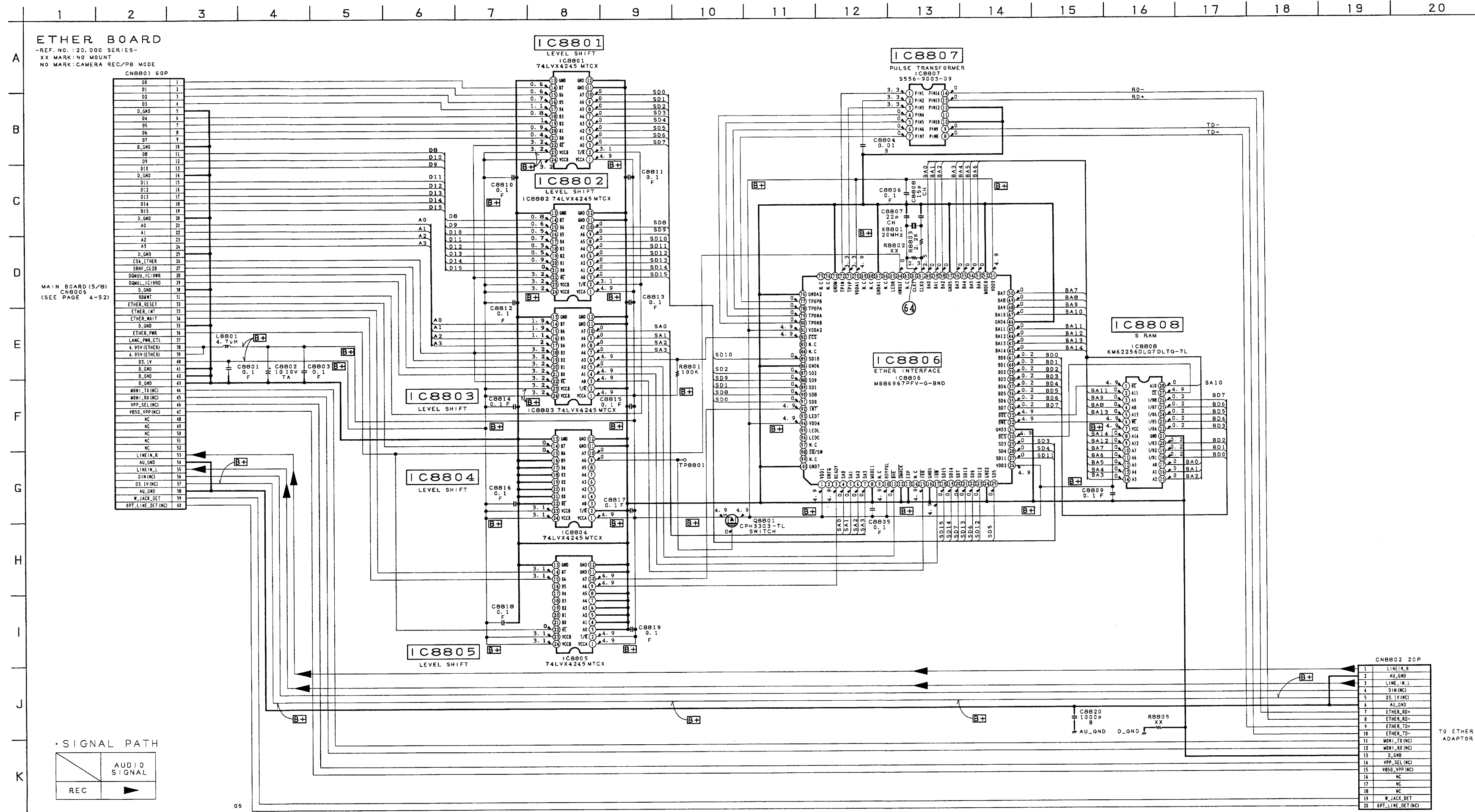

JACK (AV IN/OUT) SCHEMATIC DIAGRAM • See page 4-121 for printed wiring board.

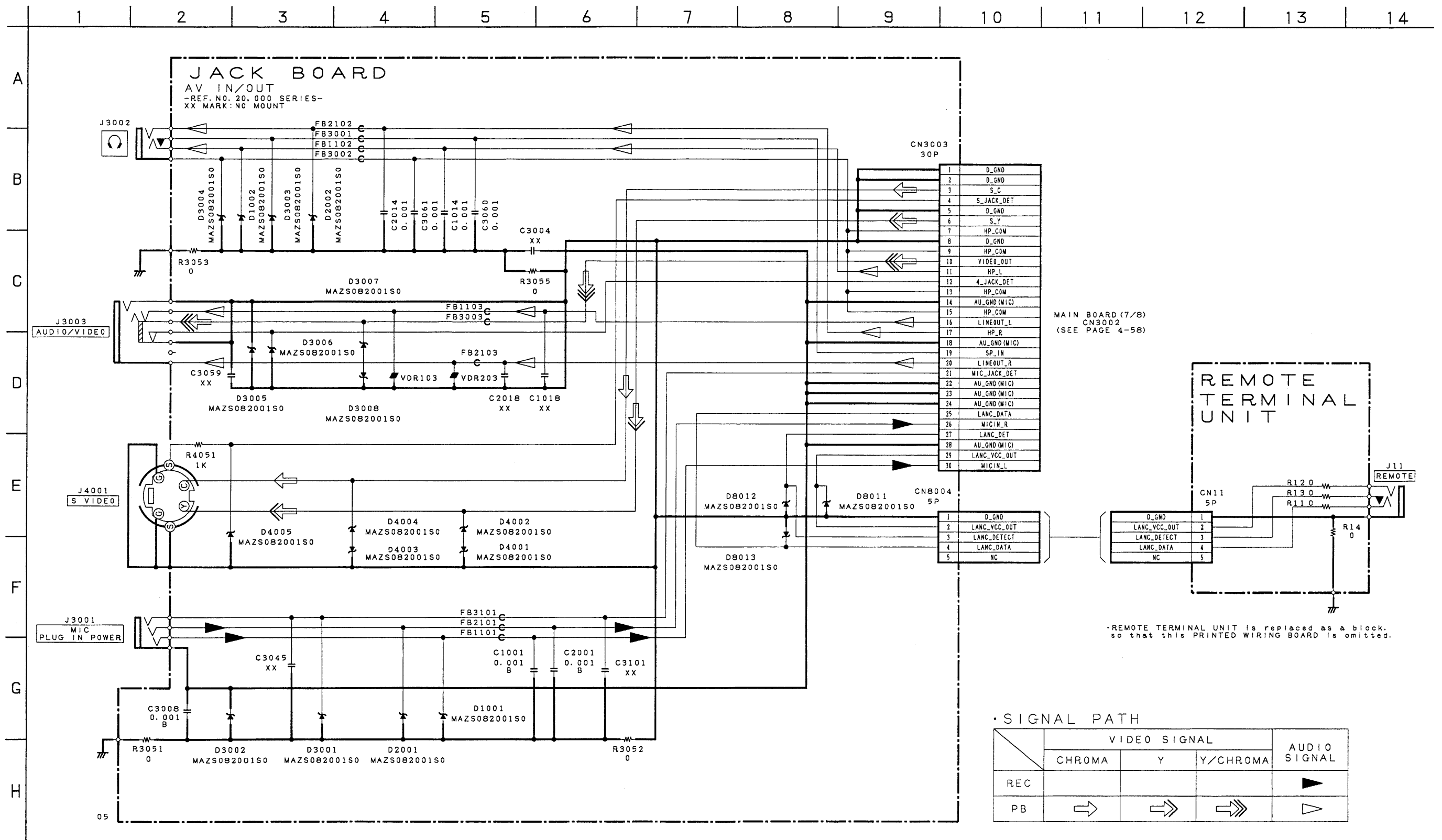

**JACK (AV IN/OUT) PRINTED WIRING BOARD**

– Ref. No.: JACK board; 20,000 series –

**JACK BOARD (SIDE A)**

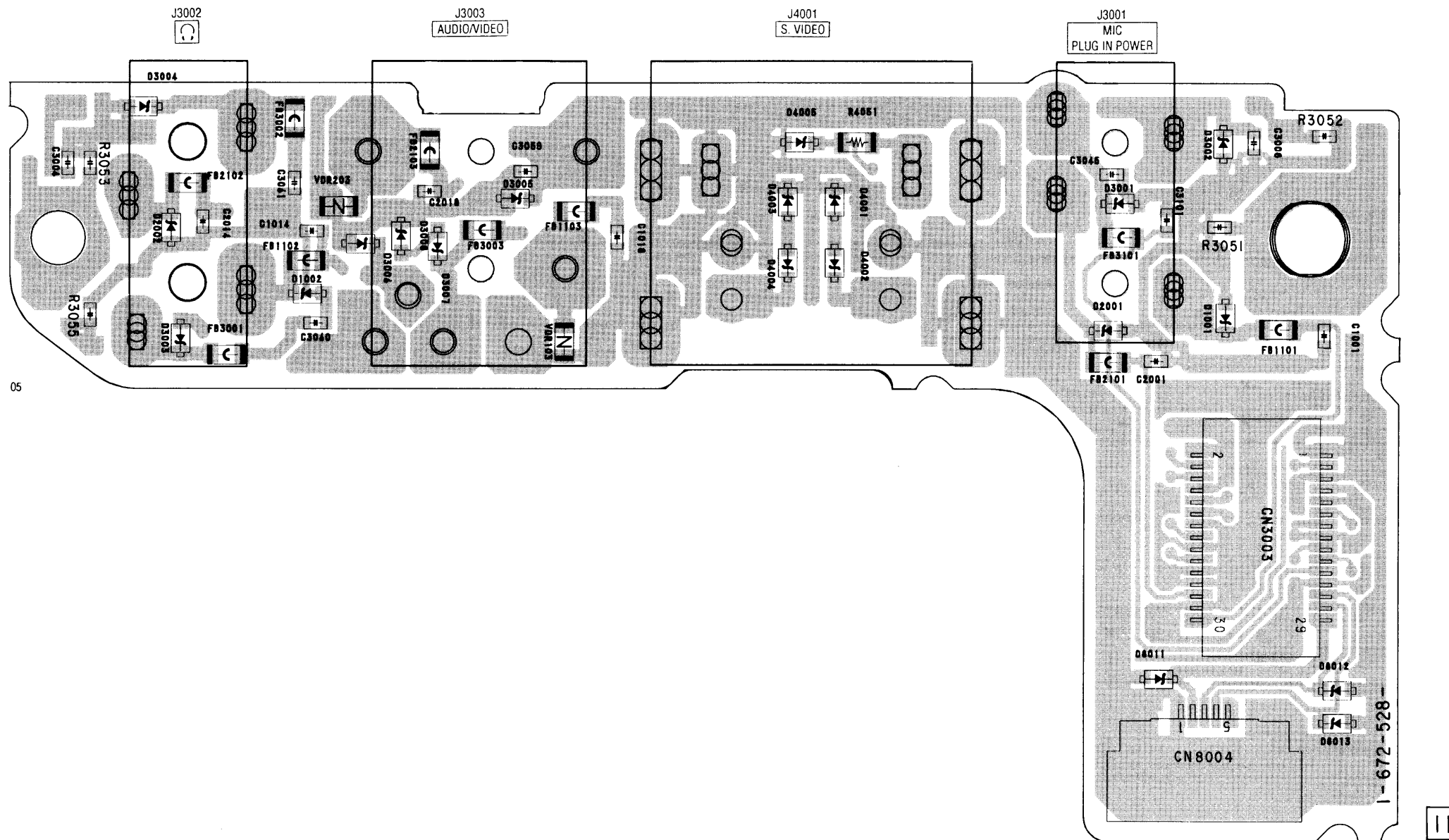

- For Printed Wiring Board.
- There are few cases that the part isn't mounted in this model is printed on this diagram.

### JACK BOARD (SIDE B)

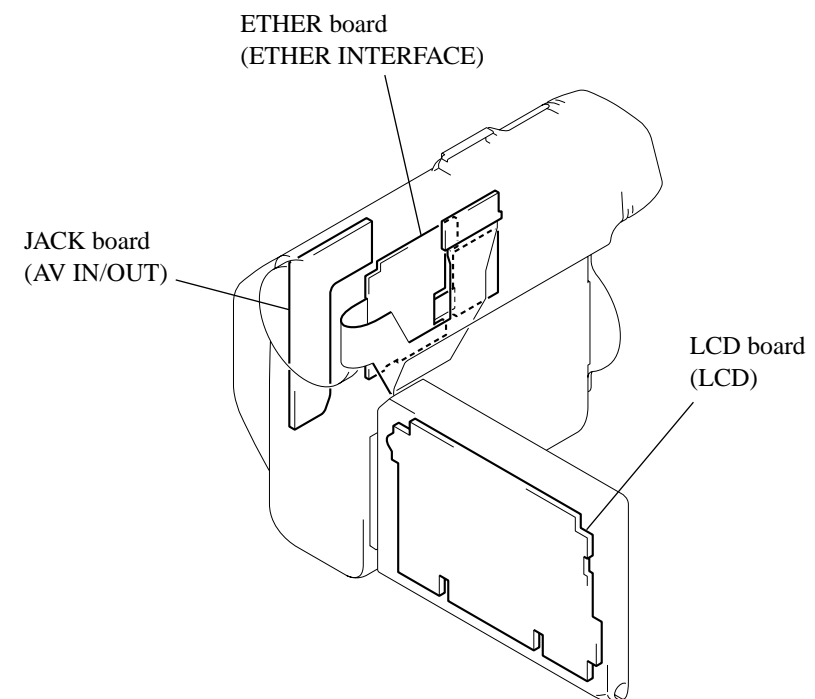
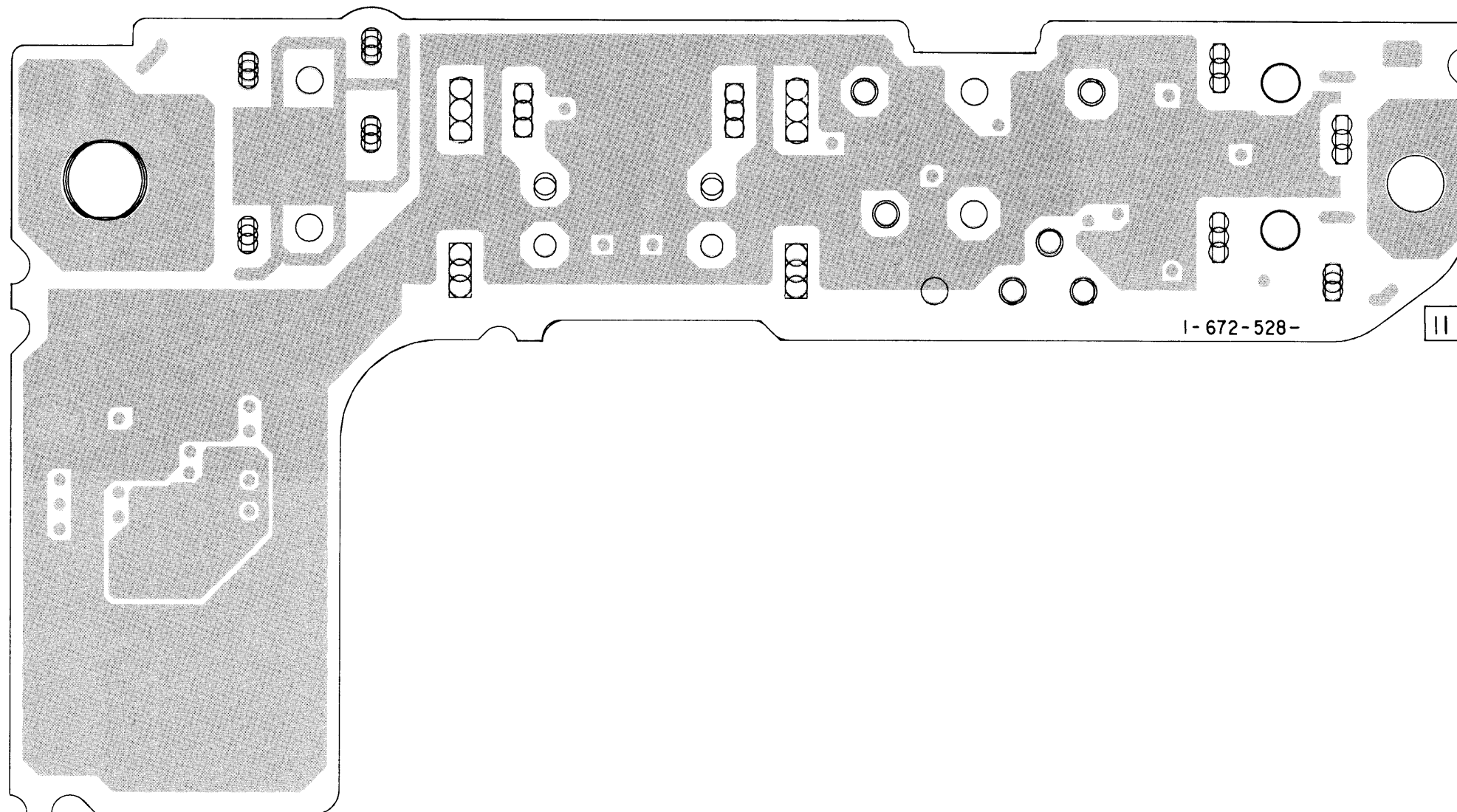

POWER (DC/DC CONVERTER) PRINTED WIRING BOARD  
- Ref. No.: POWER board; 20,000 series -

- POWER BOARD (SIDE A)
- C9001 A-10
  - C9002 A-10
  - C9003 A-10
  - C9004 C-9
  - C9009 C-8
  - C9011 C-8
  - C9015 C-6
  - C9052 A-9
  - C9055 C-5
  - C9057 C-5
  - C9061 C-5
  - C9063 C-5
  - C9064 C-1
  - C9065 C-4
  - C9068 C-1
  - C9076 C-4
  - C9080 C-5
  - 
  - CN9001 G-1
  - 
  - D9001 A-10
  - D9002 C-9
  - D9003 C-9
  - D9011 A-10
  - D9012 B-1
  - 
  - F9001 C-10
  - F9002 B-10
  - 
  - FB9001 A-10
  - FB9002 A-9
  - 
  - L9001 C-9
  - L9002 B-9
  - L9003 C-7
  - L9004 B-8
  - L9005 B-7
  - L9006 C-6
  - L9007 B-6
  - L9008 B-3
  - L9009 B-5
  - L9010 B-2
  - L9013 A-5
  - L9015 B-1
  - L9017 C-5
  - L9018 C-4
  - L9019 C-5
  - L9023 C-4
  - 
  - R9060 C-2
  - R9062 B-5
  - R9064 C-3
  - R9066 B-3
  - R9067 A-4
  - R9068 C-2
  - 
  - T9001 B-1

POWER BOARD (SIDE A)

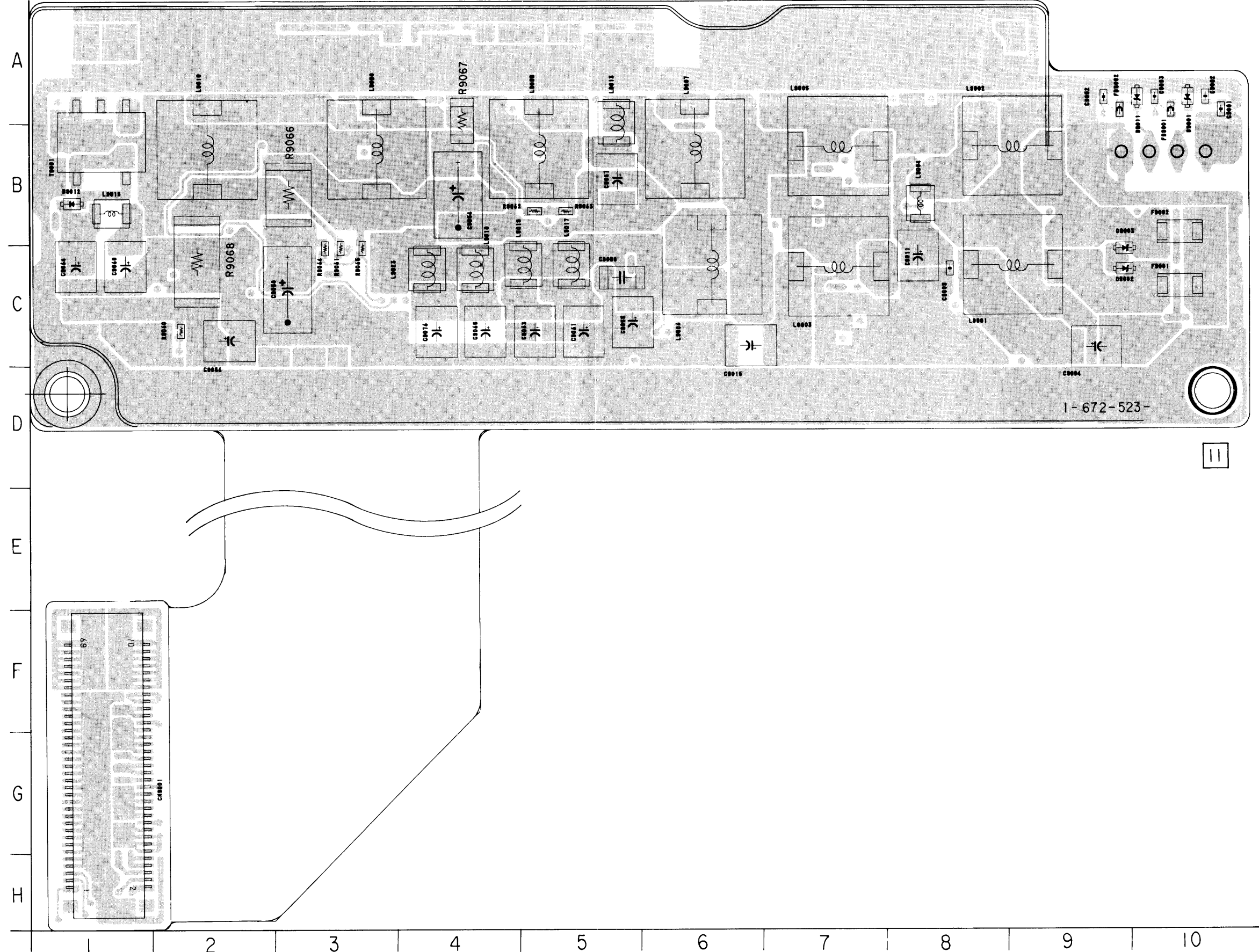

- For Printed Wiring Board.
- There are few cases that the part isn't mounted in this model is printed on this diagram.
- Chip transistor

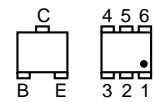

**POWER BOARD (SIDE B)**

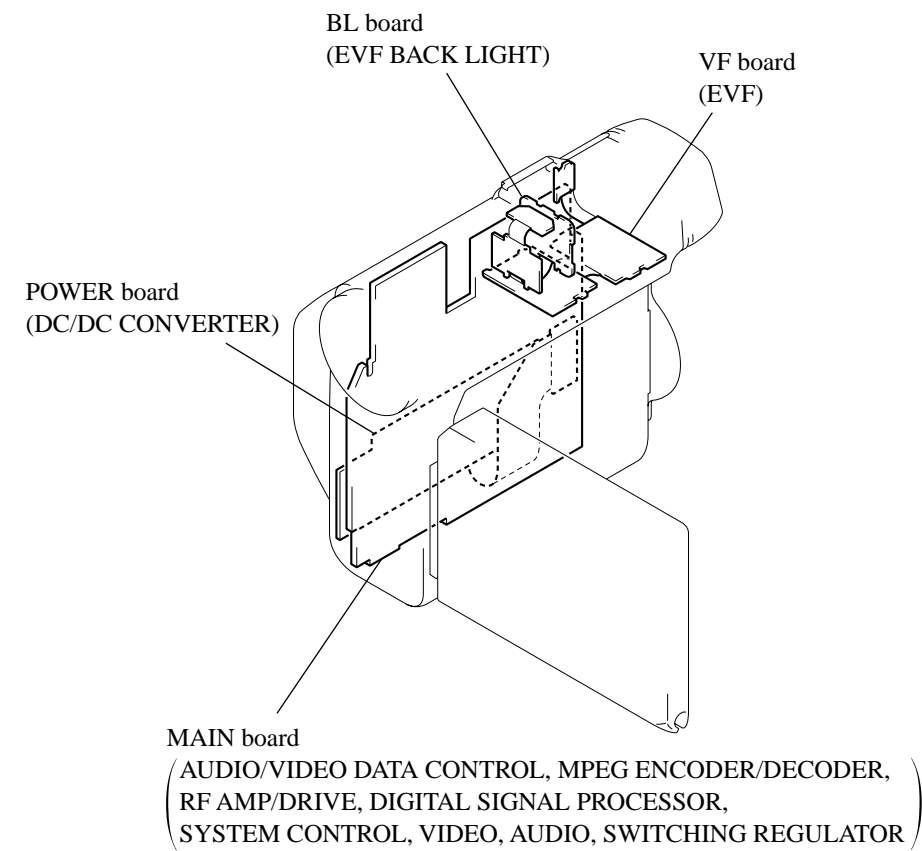
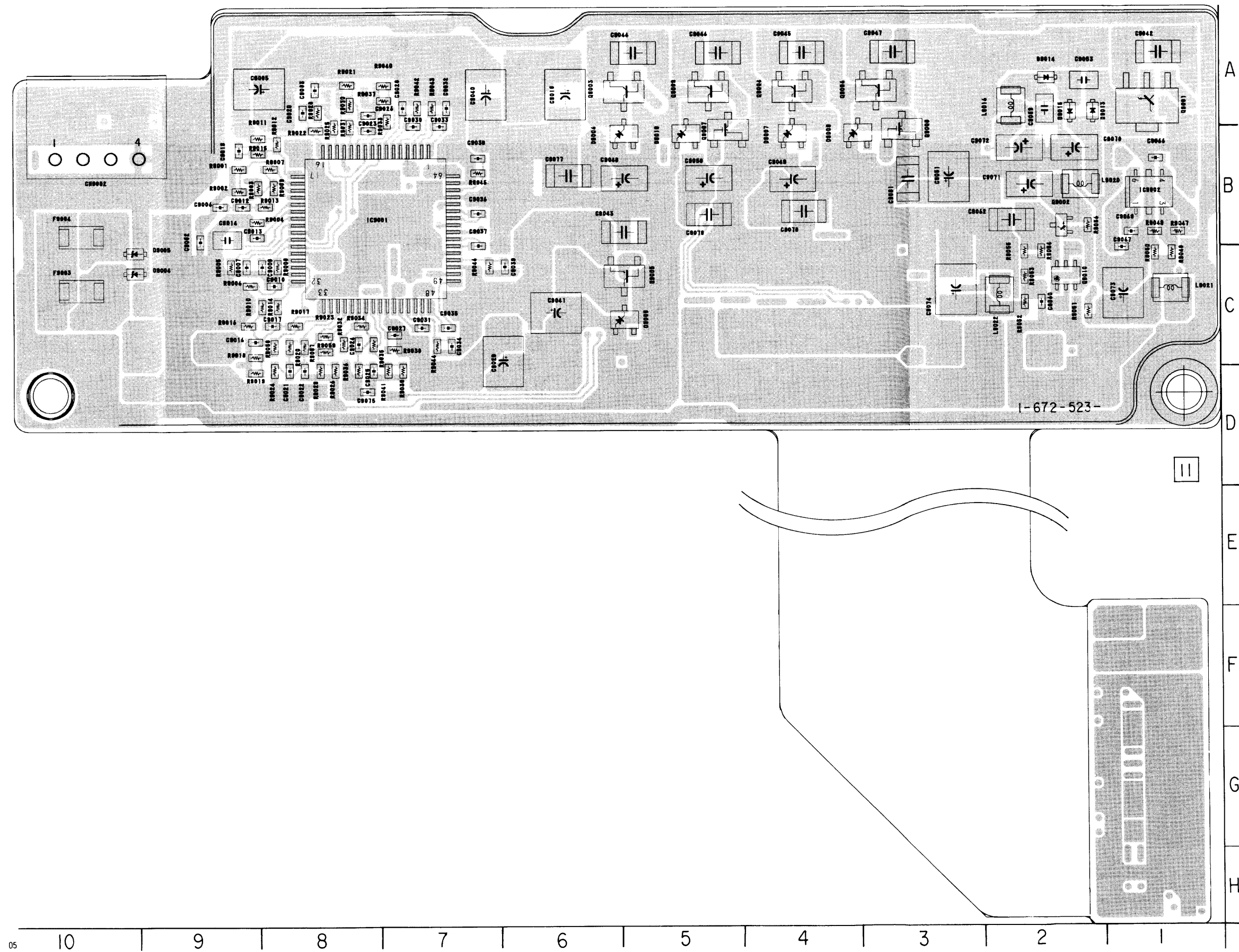

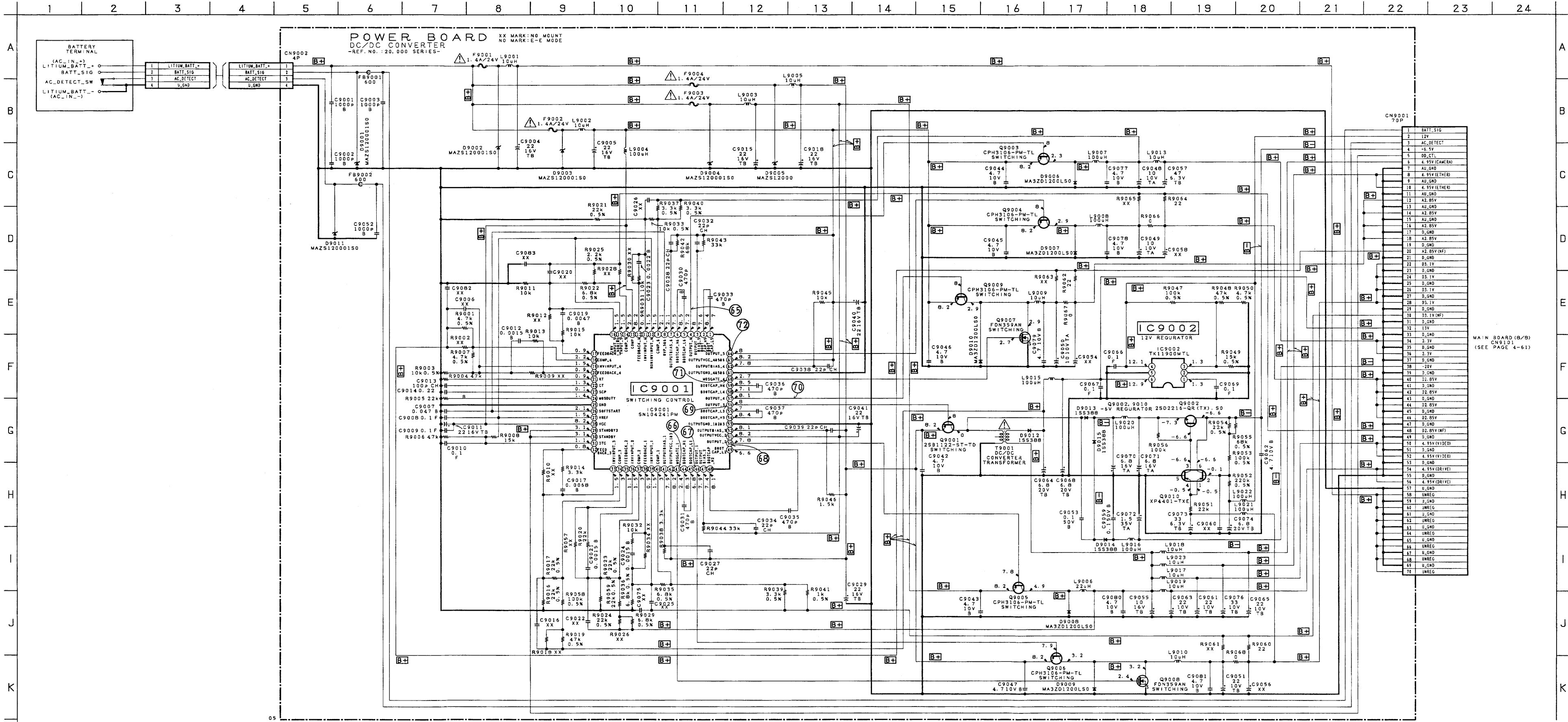









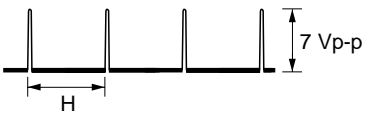
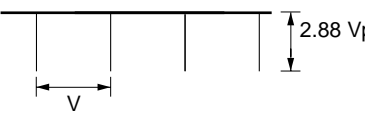
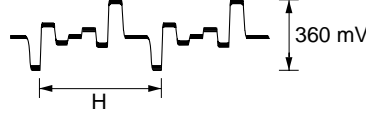
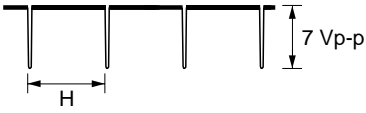
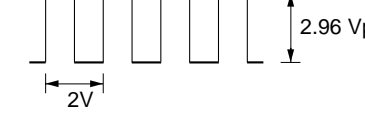

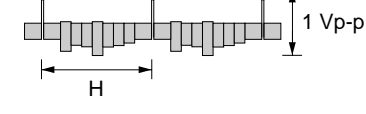
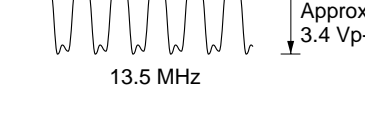
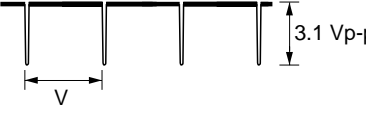
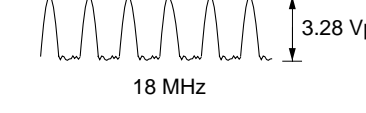
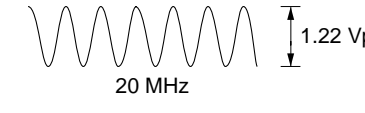
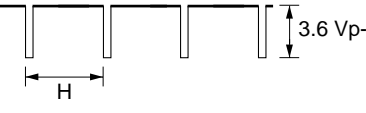
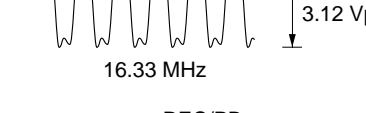

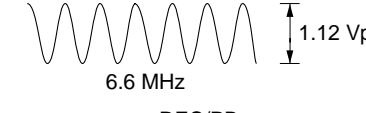

**Note:**  
The components identified by mark  $\Delta$  or dotted line with mark  $\Delta$  are critical for safety. Replace only with part number specified.

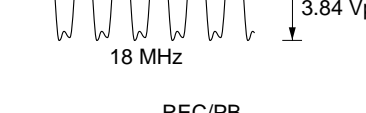
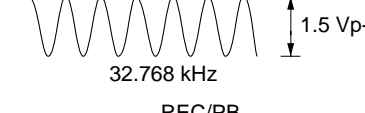
**Note:**  
Les composants identifiés par une marque  $\Delta$  ou une ligne pointillée avec une marque  $\Delta$  sont critiques pour la sécurité. Ne les remplacer que par une pièce portant le numéro spécifié.

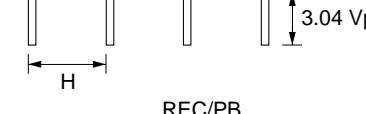

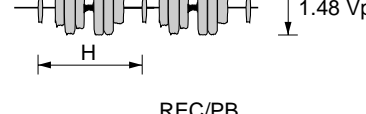
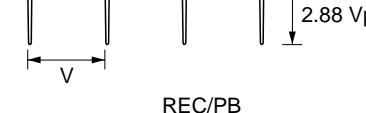

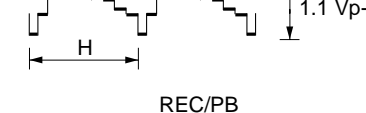



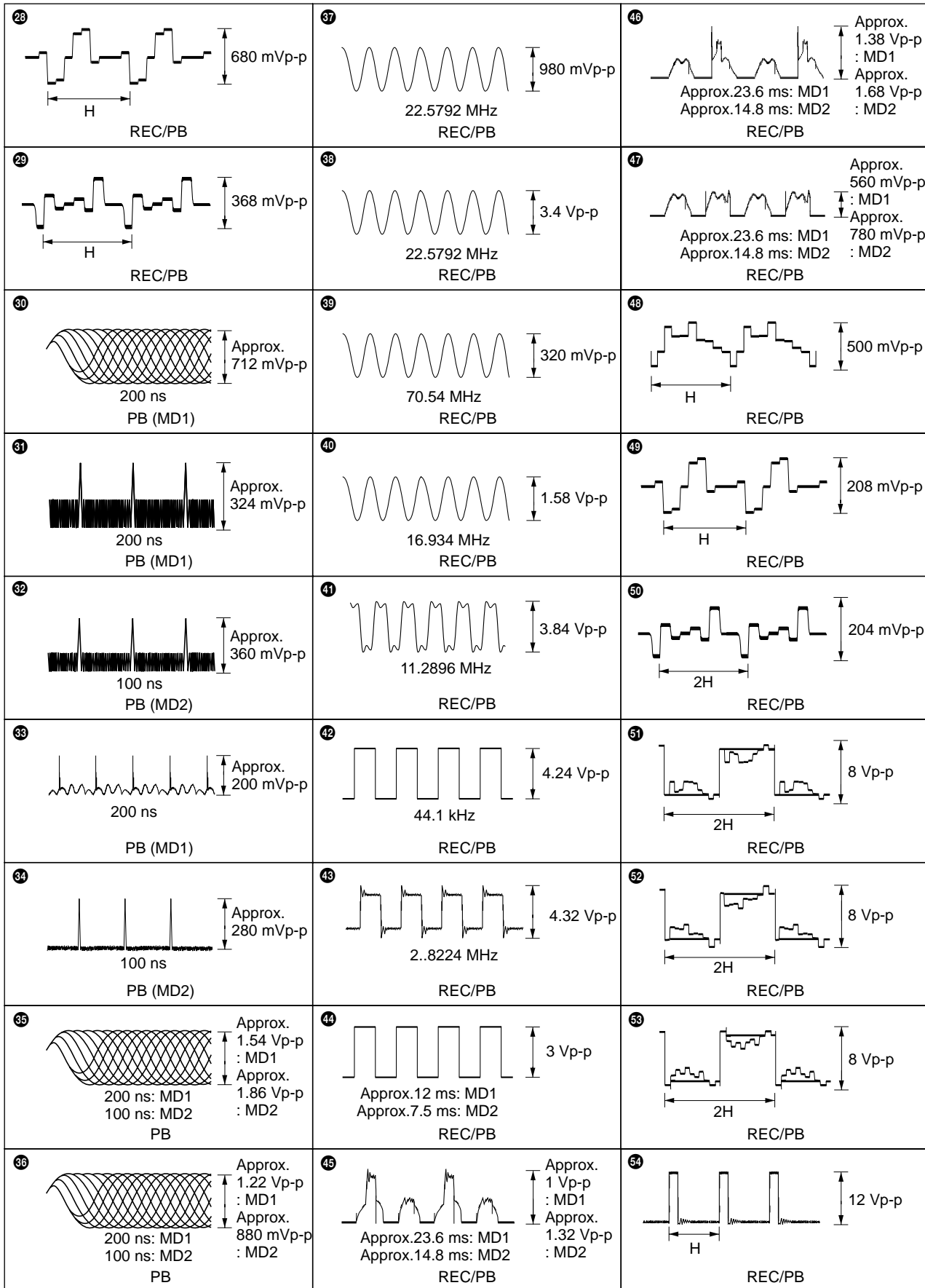





MAIN BOARD (B/B) CN9001 (SEE PAGE 4-61)

4-3. WAVEFORMS

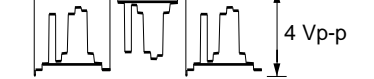
<p><b>1</b></p>  <p>7 Vp-p</p> <p>REC/PB</p>	<p><b>10</b></p>  <p>2.88 Vp-p</p> <p>REC/PB</p>	<p><b>19</b></p>  <p>360 mVp-p</p> <p>REC/PB</p>
<p><b>2</b></p>  <p>7 Vp-p</p> <p>REC/PB</p>	<p><b>11</b></p>  <p>2.96 Vp-p</p> <p>REC/PB</p>	<p><b>20</b></p>  <p>1.12 Vp-p</p> <p>REC/PB</p>
<p><b>3</b></p>  <p>1 Vp-p</p> <p>REC/PB</p>	<p><b>12</b></p>  <p>Approx. 3.4 Vp-p</p> <p>13.5 MHz</p> <p>REC/PB</p>	<p><b>21</b></p>  <p>3.1 Vp-p</p> <p>REC/PB</p>
<p><b>4</b></p>  <p>3.28 Vp-p</p> <p>18 MHz</p> <p>REC/PB</p>	<p><b>13</b></p>  <p>1.22 Vp-p</p> <p>20 MHz</p> <p>REC/PB</p>	<p><b>22</b></p>  <p>3.6 Vp-p</p> <p>REC/PB</p>
<p><b>5</b></p>  <p>3.12 Vp-p</p> <p>16.33 MHz</p> <p>REC/PB</p>	<p><b>14</b></p>  <p>408 mVp-p</p> <p>32.768 kHz</p> <p>REC/PB</p>	<p><b>23</b></p>  <p>1.12 Vp-p</p> <p>6.6 MHz</p> <p>REC/PB</p>
<p><b>6</b></p>  <p>2.24 Vp-p</p> <p>36 MHz</p> <p>REC/PB</p>	<p><b>15</b></p>  <p>1.1 Vp-p</p> <p>9.8304 MHz</p> <p>REC/PB</p>	<p><b>24</b></p>  <p>2.32 Vp-p</p> <p>REC/PB</p>
<p><b>7</b></p>  <p>3.84 Vp-p</p> <p>18 MHz</p> <p>REC/PB</p>	<p><b>16</b></p>  <p>1.5 Vp-p</p> <p>32.768 kHz</p> <p>REC/PB</p>	<p><b>25</b></p>  <p>2.04 Vp-p</p> <p>REC/PB</p>
<p><b>8</b></p>  <p>3.04 Vp-p</p> <p>REC/PB</p>	<p><b>17</b></p>  <p>3.52 Vp-p</p> <p>27 MHz</p> <p>REC/PB</p>	<p><b>26</b></p>  <p>1.48 Vp-p</p> <p>REC/PB</p>
<p><b>9</b></p>  <p>2.88 Vp-p</p> <p>REC/PB</p>	<p><b>18</b></p>  <p>700 mVp-p</p> <p>REC/PB</p>	<p><b>27</b></p>  <p>1.1 Vp-p</p> <p>REC/PB</p>

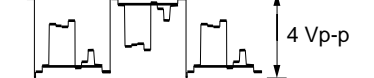
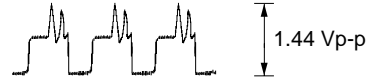
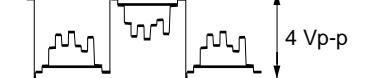
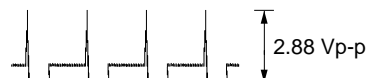
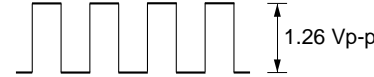



<p>55</p>  <p>2.16 Vp-p 11 MHz REC/PB</p>	<p>64</p>  <p>1.28 Vp-p 20 MHz REC/PB</p>
<p>56</p>  <p>560 mVp-p H REC/PB</p>	<p>65</p>  <p>800 mVp-p 470 kHz REC/PB</p>
<p>57</p>  <p>220 mVp-p H REC/PB</p>	<p>66</p>  <p>5.52 Vp-p 470 kHz REC/PB</p>
<p>58</p>  <p>236 mVp-p H REC/PB</p>	<p>67</p>  <p>940 mVp-p 470 kHz REC/PB</p>
<p>59</p>  <p>4 Vp-p 2H REC/PB</p>	<p>68</p>  <p>840 mVp-p 470 kHz REC/PB</p>
<p>60</p>  <p>4 Vp-p 2H REC/PB</p>	<p>69</p>  <p>1.44 Vp-p 470 kHz REC/PB</p>
<p>61</p>  <p>4 Vp-p 2H REC/PB</p>	<p>70</p>  <p>2.88 Vp-p 470 kHz REC/PB</p>
<p>62</p>  <p>1.26 Vp-p 2H REC/PB</p>	<p>71</p>  <p>5.44 Vp-p 470 kHz REC/PB</p>
<p>63</p>  <p>3.12 Vp-p 15.4 MHz REC/PB</p>	<p>72</p>  <p>840 mVp-p 470 kHz REC/PB</p>

# SECTION 5 EXPLODED VIEWS

**NOTE:**

- XX and -X mean standardized parts, so they may have some difference from the original one.
- Color Indication of Appearance Parts  
Example:  
KNOB, BALANCE (WHITE) . . . (RED)  
                                ↑                                ↑  
                Parts Color    Cabinet's Color

- Items marked "\*" are not stocked since they are seldom required for routine service. Some delay should be anticipated when ordering these items.
- The mechanical parts with no reference number in the exploded views are not supplied.
- Hardware (# mark) list and accessories and packing materials are given in the last of the electrical parts list.

The components identified by mark  $\triangle$  or dotted line with mark  $\triangle$  are critical for safety. Replace only with part number specified.

---

Les composants identifiés par une marque  $\triangle$  sont critiques pour la sécurité. Ne les remplacer que par une pièce portant le numéro spécifié.

## 5-1. MAIN SECTION

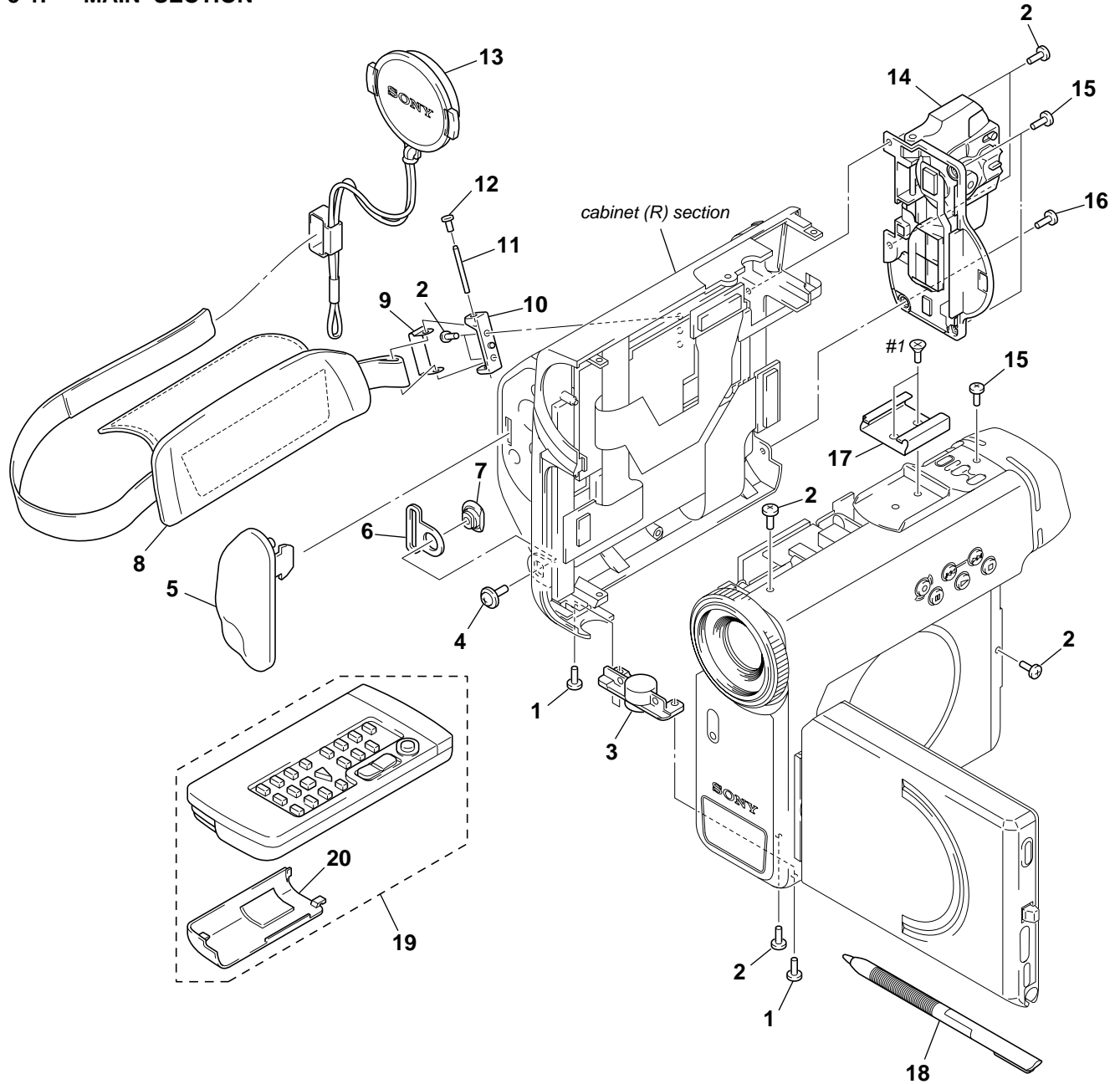

Ref. No.	Part No.	Description	Remark	Ref. No.	Part No.	Description	Remark
1	4-223-679-23	SCREW (2.0), MI (M2.0X4.5)		11	4-216-049-01	SHAFT (BRACKET REAR)	
2	4-223-676-15	SCREW (1.7), MI (M1.7X3)		12	4-219-035-01	SCREW	
3	3-977-650-01	SCREW, TRIPOD		13	X-4951-294-1	CAP ASSY, LENS	
4	4-218-461-11	SCREW (M1.7)		14	1-418-201-21	SWITCH UNIT, MAIN CONTROL	
5	4-216-024-01	COVER, JACK		15	4-223-676-23	SCREW (1.7), MI (M1.7X4)	
6	4-216-022-01	BRACKET, BELT		16	4-223-676-31	SCREW (1.7), MI (M1.7X4.5)	
7	4-216-023-01	SHAFT (BELT FRONT)		17	4-220-888-01	BRACKET (SHOE)	
8	4-218-462-01	BELT, GRIP		18	X-4950-890-1	PEN ASSY, TOUCH	
9	4-221-110-01	BRACKET		19	1-418-732-21	REMOTE COMMANDER (RMT-DCM1)	
10	4-216-036-01	BRACKET (REAR), BELT		20	3-742-854-01	LID, BATTERY (for RMT-DCM1)	

## 5-2. CABINET (R) SECTION

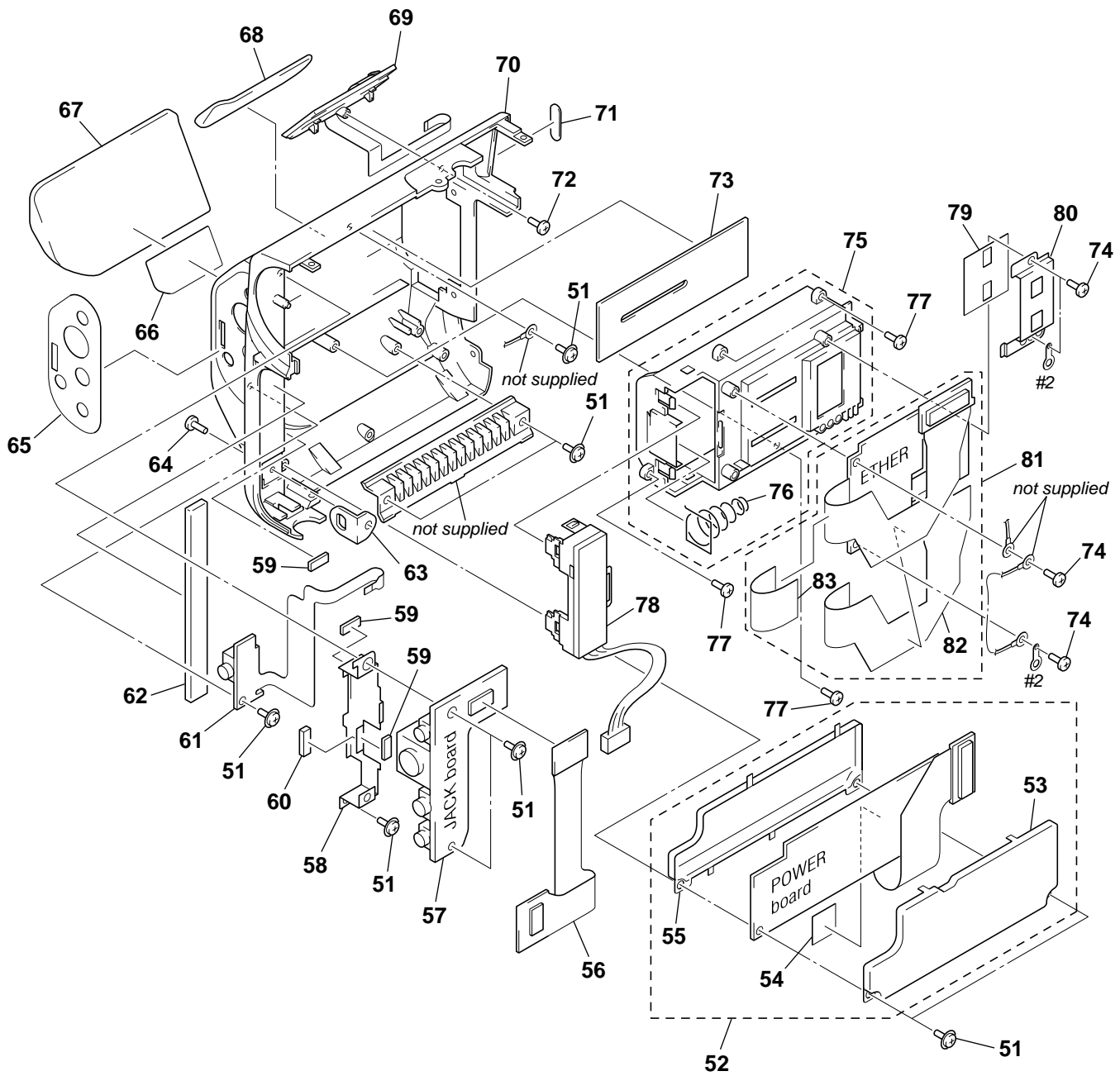

Ref. No.	Part No.	Description	Remark	Ref. No.	Part No.	Description	Remark
51	4-218-461-01	SCREW (M1.7)		68	3-043-016-01	RUBBER, GRIP	
52	A-3321-881-A	POWER BOARD, COMPLETE		69	1-418-202-21	SWITCH UNIT, ZOOM	
* 53	4-216-028-01	CASE (REAR), SHIELD		70	X-3378-880-1	CABINET (R) SUB ASSY	
54	3-043-103-01	CUSHION (SHIELD)		71	4-216-052-01	BLIND (EVF), ADJUSTMENT	
* 55	4-216-027-01	CASE (FRONT), SHIELD		72	4-984-017-21	SCREW (1.7), TAPPING	
56	1-672-513-11	TRANSLATION FLEXIBLE (JACK) BOARD		73	4-215-993-01	SHEET, BT	
57	A-3321-883-A	JACK BOARD, COMPLETE		74	3-713-791-01	SCREW (M1.7X5), TAPPING, P2	
58	4-216-025-01	BRACKET (JACK)		75	X-4950-899-1	CASE ASSY, BATTERY	
59	4-224-946-01	SPACER (JACK)		76	3-972-819-01	SPRING, BATTERY	
60	4-224-945-01	SPACER (REMOTE TERMINAL)		77	4-223-676-23	SCREW (1.7), M1 (M1.7X4)	
61	1-418-563-11	TERMINAL UNIT, REMOTE		78	1-694-497-11	TERMINAL BOARD, BATTERY	
* 62	4-220-720-01	MATERIAL, ACOUSTIC ISOLATION (M)		79	4-219-034-01	SHEET, INSULATING	
63	4-216-021-01	BRACKET (FRONT), BELT		80	4-215-995-01	BRACKET (ETHER PC BOARD)	
64	4-223-676-15	SCREW (1.7), M1 (M1.7X3)		81	A-3323-174-A	ETHER BOARD, COMPLETE	
65	4-225-467-01	SEAL (JACK. ENGLISH)		82	3-043-261-01	SHEET, COPY	
66	3-043-483-01	SHEET (GRIP RUBBER), ADHESIVE		83	3-044-616-01	SHEET, SHIELD	
67	3-043-015-01	RUBBER, GRIP					

### 5-3. MICROPHONE BLOCK SECTION

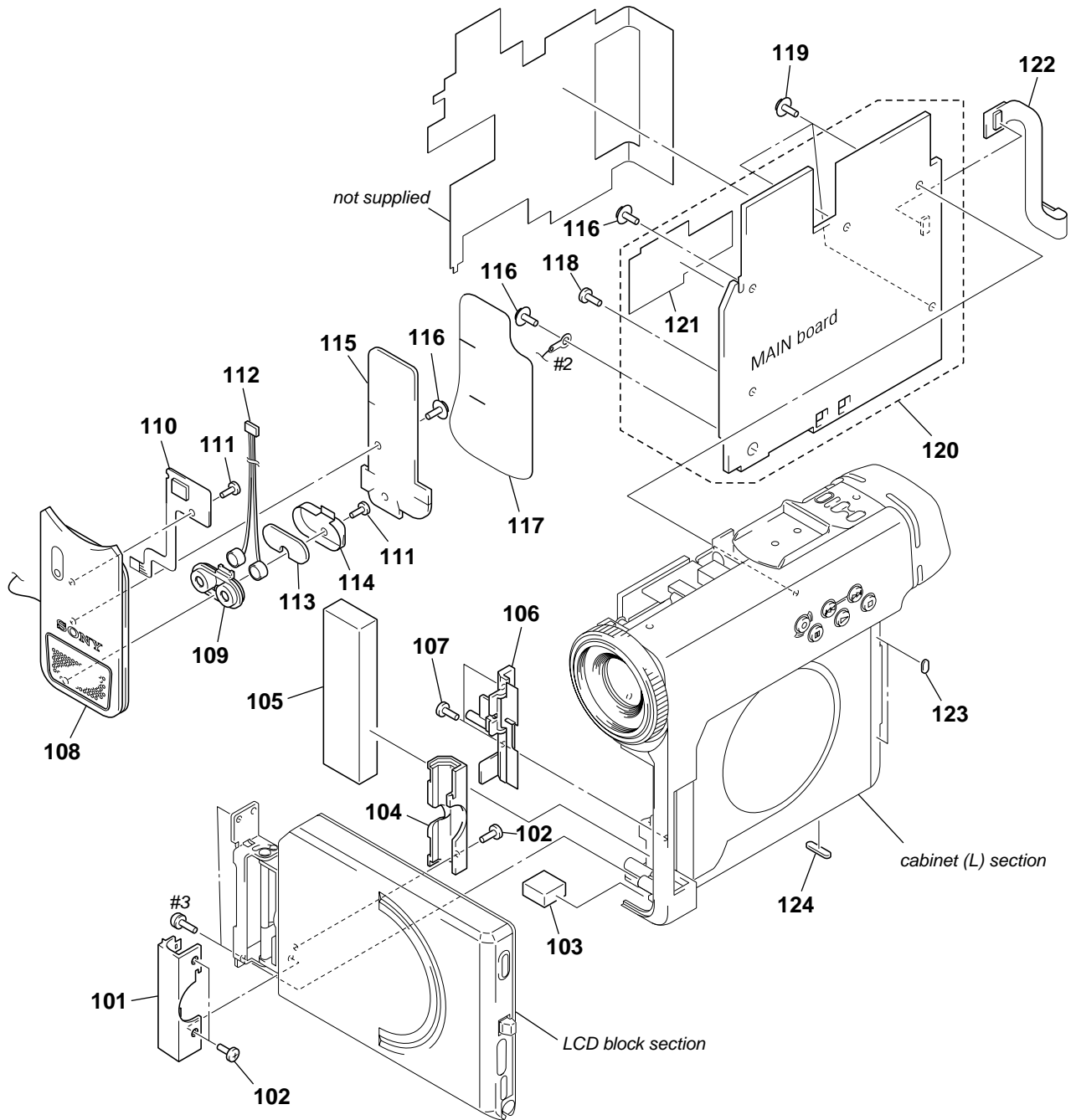

Ref. No.	Part No.	Description	Remark	Ref. No.	Part No.	Description	Remark
101	4-216-044-01	COVER (FRONT), HINGE		113	4-220-639-01	ABSORBENT (GEL), ACOUSTIC	
102	4-223-676-15	SCREW (1.7), MI (M1.7X3)		114	4-216-019-01	COVER, BASE	
* 103	4-220-721-01	MATERIAL, ACOUSTIC ISOLATION (S)		115	3-043-171-01	SHEET (MICROPHONE)	
104	4-216-045-01	COVER (REAR), HINGE		116	4-218-461-01	SCREW (M1.7)	
* 105	4-220-719-01	MATERIAL, ACOUSTIC ISOLATION (L)		117	4-220-640-01	ABSORBENT (SHEET), ACOUSTIC	
106	X-4950-891-1	PLATE ASSY, BLIND		118	3-713-791-01	SCREW (M1.7X5), TAPPING, P2	
107	4-223-676-09	SCREW (1.7), MI (M1.7X2.5)		119	3-335-797-01	SCREW (M1.4X2), TOOTHED LOCK	
108	X-4950-897-1	BASE ASSY, MICROPHONE		120	A-3323-422-A	MAIN BOARD, COMPLETE	
109	4-216-018-01	RUBBER, MICROPHONE		121	3-044-612-01	SHEET, SHIELD (1C3009)	
110	1-418-564-11	RAY-CATCHER BLOCK UNIT, REMOCON		122	1-672-514-11	TRANSLATION FLEXIBLE BOARD	
111	4-984-017-21	SCREW (1.7), TAPPING		123	4-215-975-21	CUSHION (PANEL)	
112	1-418-192-11	MICROPHONE UNIT		124	3-043-102-01	FOOT (L), RUBBER	

## 5-4. CABINET (L) SECTION

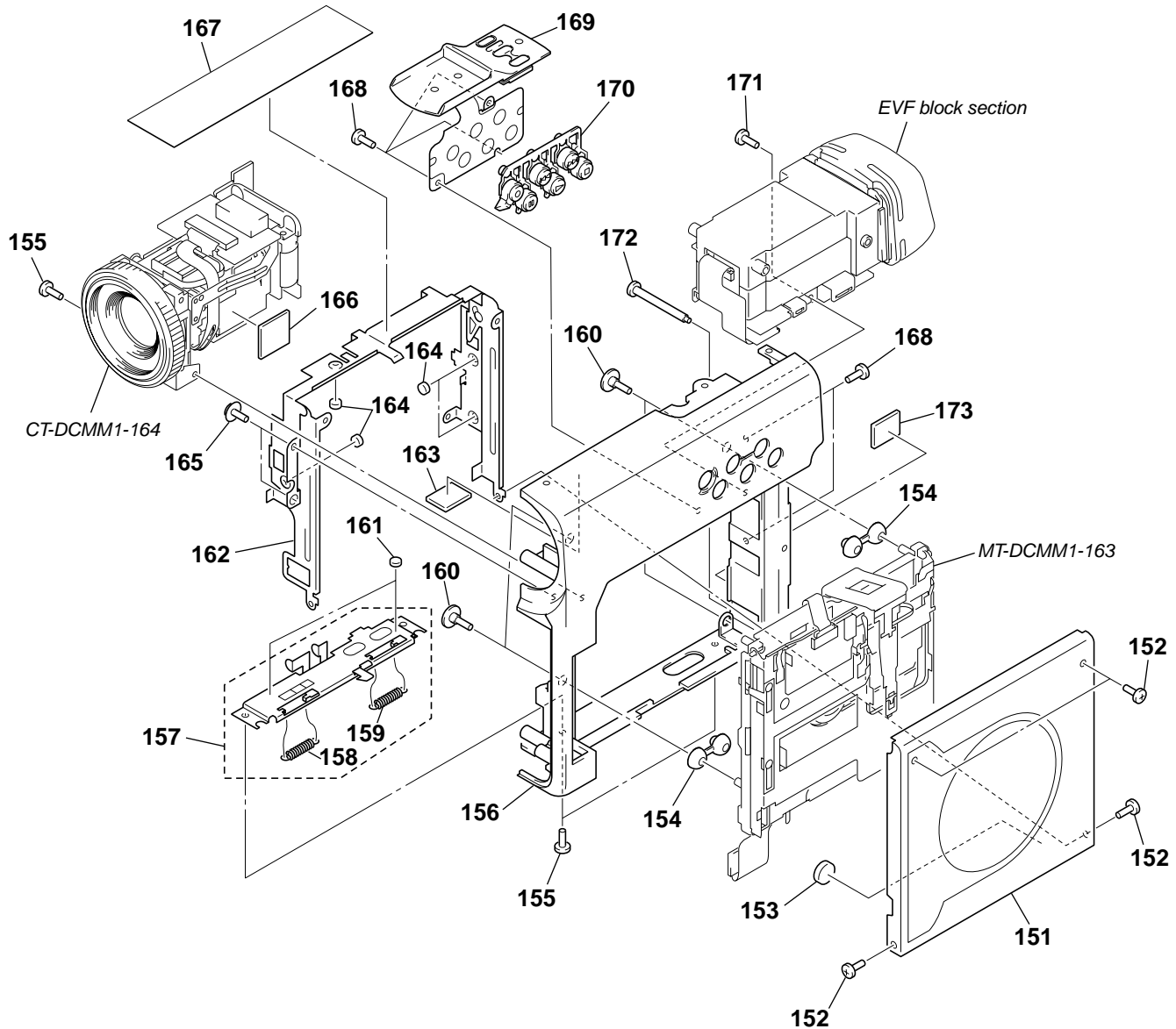

Ref. No.	Part No.	Description	Remark	Ref. No.	Part No.	Description	Remark
151	X-3378-420-1	PANEL ASSY, UPPER		163	3-837-971-01	CUSHION	
152	4-218-229-19	SCREW (1.4), MI (M1.4X2)		164	4-215-989-01	CUSHION (MD)	
153	3-320-382-11	FOOT, RUBBER		165	4-218-461-01	SCREW (M1.7)	
154	4-218-458-01	DAMPER (MD)		166	4-220-349-01	CUSHION (CAMERA)	
155	4-223-676-15	SCREW (1.7), MI (M1.7X3)		167	4-216-053-01	CUSHION (CABINET)	
156	X-3378-881-1	CABINET (FRONT) ASSY		168	4-223-676-09	SCREW (1.7), MI (M1.7X2.5)	
157	X-4950-893-1	CHASSIS (F) ASSY		169	X-3378-951-1	CONTROL SW SUB ASSY, UPPER	
158	4-995-402-01	SPRING (LOCK), TENSION		170	X-4950-892-1	BUTTON ASSY, AUDIO CONTROL	
159	3-914-116-01	SPRING (R), TENSION		171	4-223-676-23	SCREW (1.7), MI (M1.7X4)	
160	4-215-976-01	SCREW (DAMPER)		172	4-221-112-01	SHAFT	
161	4-215-989-21	CUSHION (MD)		173	3-842-935-01	CUSHION	
162	X-4950-894-1	CHASSIS (M) ASSY					

### 5-5. LCD BLOCK SECTION

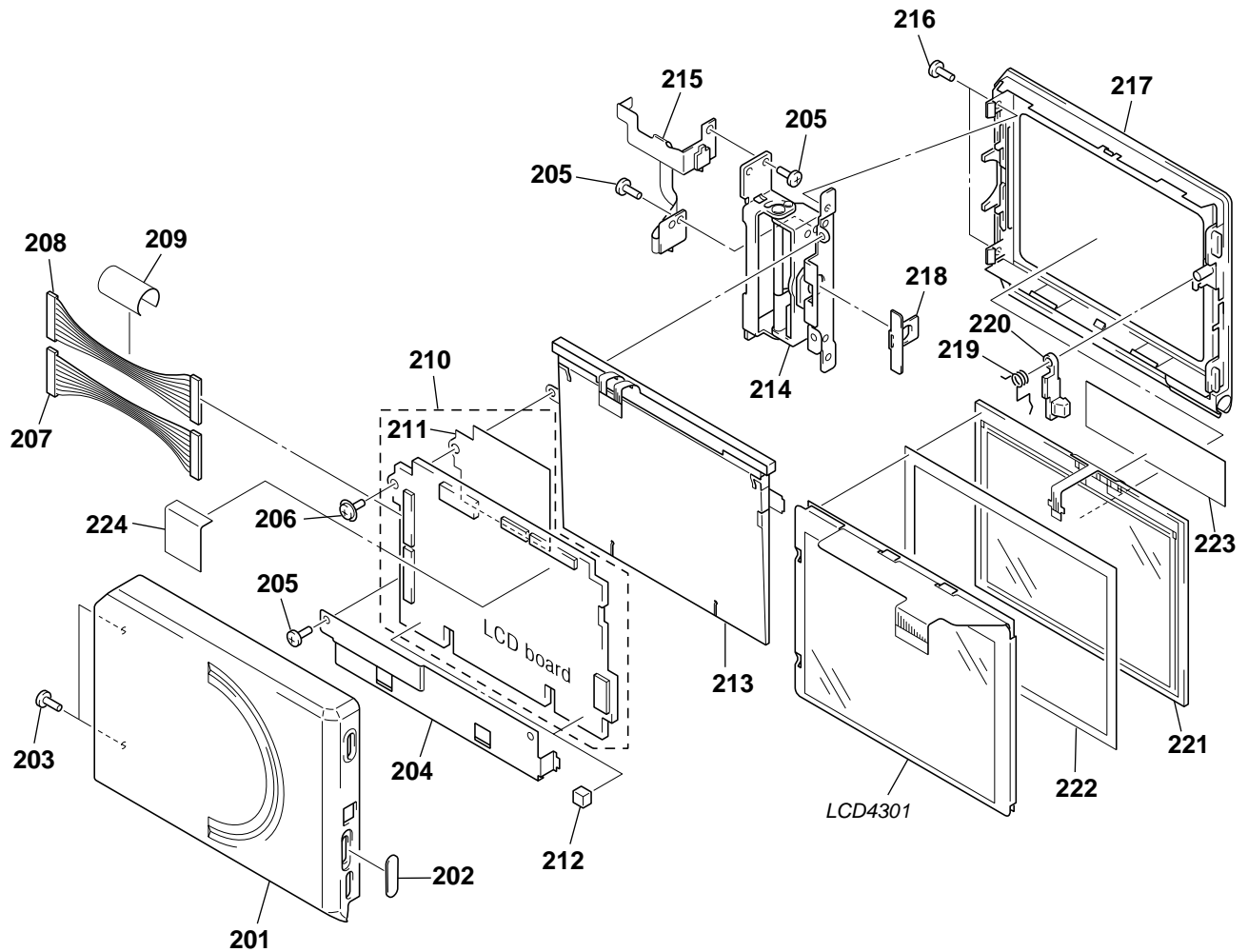

<p>The components identified by mark <math>\Delta</math> or dotted line with mark <math>\Delta</math> are critical for safety. Replace only with part number specified.</p>	<p>Les composants identifiés par une marque <math>\Delta</math> sont critiques pour la sécurité. Ne les remplacer que par une pièce portant le numéro spécifié.</p>
---	---

Ref. No.	Part No.	Description	Remark	Ref. No.	Part No.	Description	Remark
201	X-3378-952-1	CABINET ASSY (U), LCD		214	X-4950-896-1	HINGE ASSY	
202	4-216-051-01	BLIND (LCD), ADJUSTMENT		215	1-672-355-11	LCD DETECTION SW FLEXIBLE BOARD	
203	4-223-676-15	SCREW (1.7), MI (M1.7X3)		216	4-223-676-07	SCREW (1.7), MI (M1.7X2)	
* 204	4-216-034-01	FRAME, LCD		217	4-216-041-01	CABINET (O), LCD	
205	4-223-676-09	SCREW (1.7), MI (M1.7X2.5)		218	3-051-046-01	SLEEVE, HARNESS	
206	4-218-461-01	SCREW (M1.7)		219	4-216-047-01	SPRING (LOCK), TORSION	
207	1-959-252-11	HARNESS (GLAY)		220	4-216-043-01	LOCK, LCD	
208	1-959-251-11	HARNESS (YELLOW)		221	1-803-445-11	PANEL, TOUCH	
209	4-220-687-01	TAPE (LCD), HARNESS BLIND		222	4-218-463-01	SPACER (LCD)	
210	A-3323-169-A	LCD BOARD, COMPLETE		223	3-042-678-01	SHEET (LCD), ELECTROSTATIC	
211	4-220-440-01	SHEET (LCD), SHIELD		224	3-042-688-01	SHEET (LCD FLEXIBLE RETAINER)	
212	4-926-578-01	PLATE (P), RUBBER		LCD4301 1-803-033-21		INDICATOR MODULE, LIQUID CRYSTAL	
$\Delta$ 213	1-517-843-11	FLUORESCENT TUBE					

## 5-6. EVF BLOCK SECTION

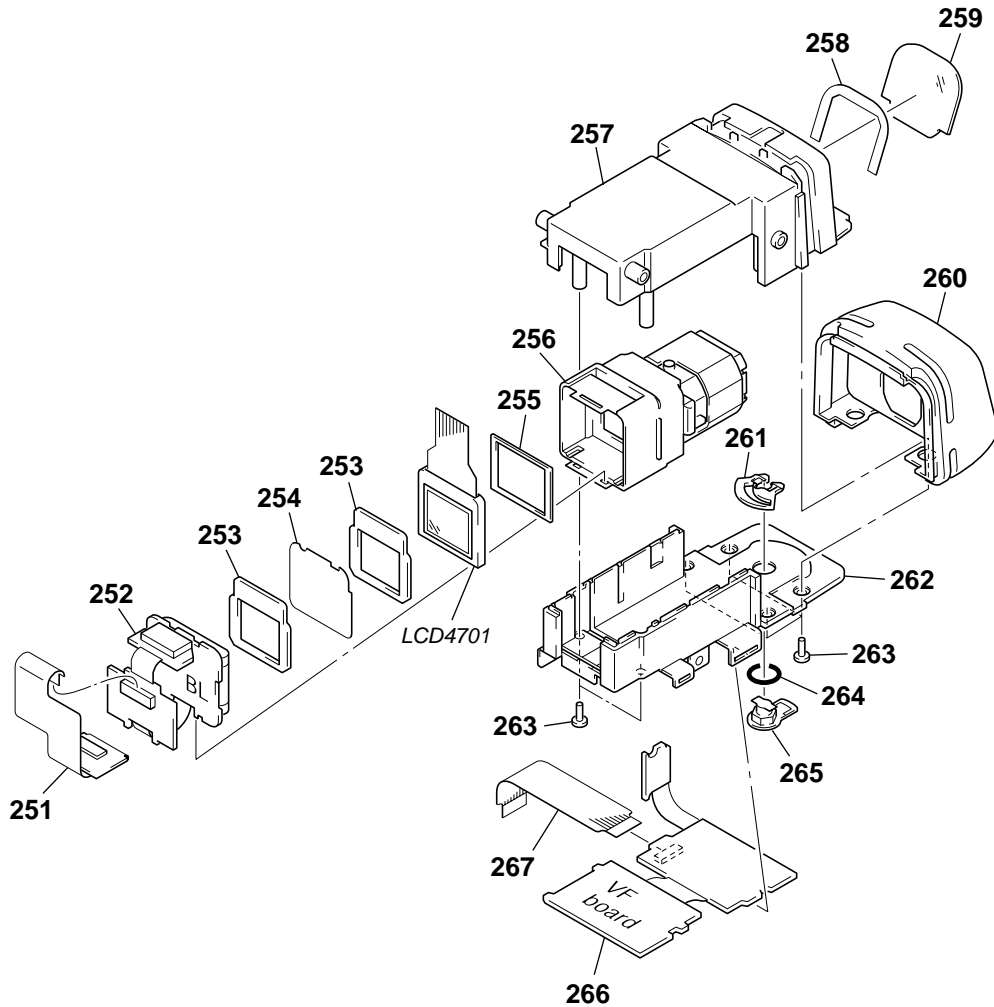

Ref. No.	Part No.	Description	Remark	Ref. No.	Part No.	Description	Remark
251	1-672-356-11	VF/LCD FLEXIBLE BOARD		260	4-216-039-01	CUP, EYE	
252	A-3321-877-A	BL BORAD, COMPLETE		261	4-218-460-01	ARM, VISIBILITY ADJUSTMENT	
253	3-989-416-01	CUSHION (458), LCD		262	4-216-040-01	CABINET (LOWER), EVF	
254	3-988-563-01	ILLUMINATOR (458), BL		263	3-713-791-01	SCREW (M1.7X5), TAPPING, P2	
255	3-960-302-11	CUSHION (1), LCD		264	3-950-044-01	RING, O	
256	X-3948-473-1	LENS ASSY (458), VF		265	4-218-459-01	KNOB, VISIBILITY ADJUSTMENT	
257	4-216-042-01	CABINET (UPPER), EVF		266	A-3321-879-A	VF BORAD, COMPLETE	
258	3-988-565-01	SHEET, VF COVER ADHESIVE		267	1-672-357-11	VF FLEXIBLE BOARD	
259	3-988-564-01	COVER, VF		LCD4701	8-753-023-89	LCX024AK-5	



**5-7. LENS BLOCK SECTION  
(CT-DCMM1-164)**

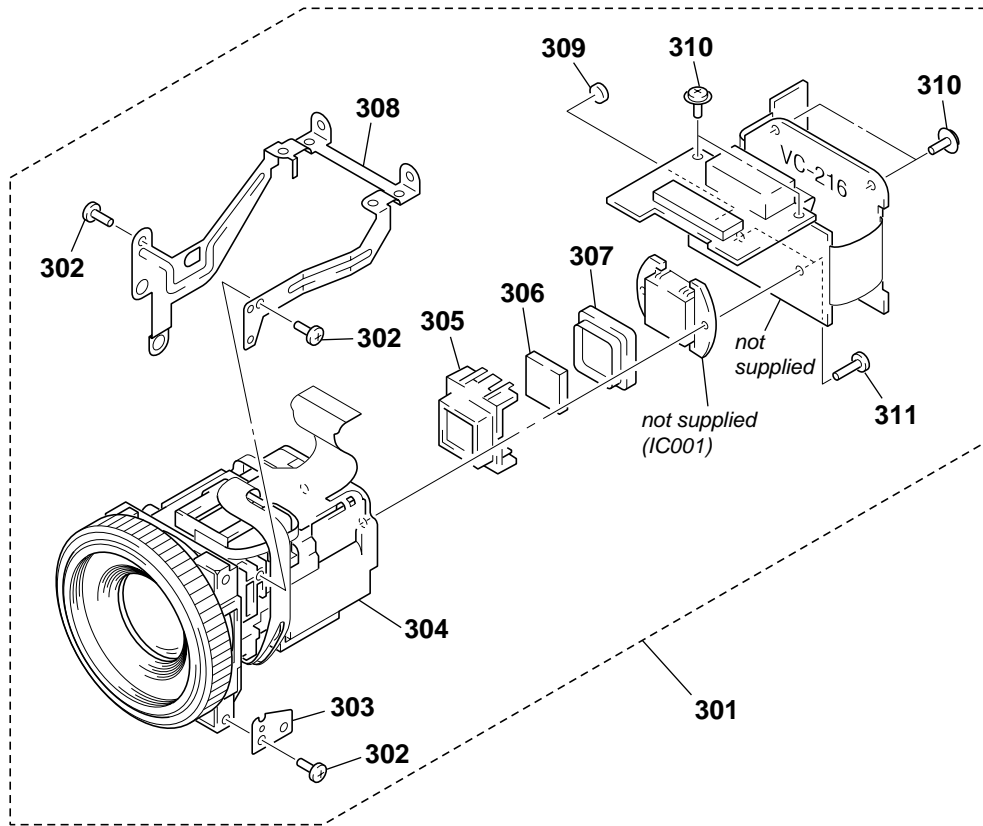

<u>Ref. No.</u>	<u>Part No.</u>	<u>Description</u>	<u>Remark</u>	<u>Ref. No.</u>	<u>Part No.</u>	<u>Description</u>	<u>Remark</u>
301	A-3250-920-A	CT-DCMM1-164		307	3-961-192-01	RUBBER (FH), SEAL	
302	3-713-791-01	SCREW (M1.7X4), TAPPING, P2		* 308	4-215-974-01	BRACKET, LENS BLOCK	
* 303	4-215-973-01	BRACKET, LENS FRAME		309	4-215-989-21	CUSHION (MD)	
304	8-848-732-01	DEVICE, LENS (LSV-620B)		310	3-335-797-01	SCREW (M1.4X2), TOOTHED LOCK	
305	3-963-467-11	ADAPTOR (FH), CCD FITTING		311	3-318-203-11	SCREW (B1.7X6), TAPPING	
306	1-758-202-21	FILTER BLOCK, OPTICAL					

5-8. MECHANISM DECK SECTION-1  
(MT-DCMM1-163)

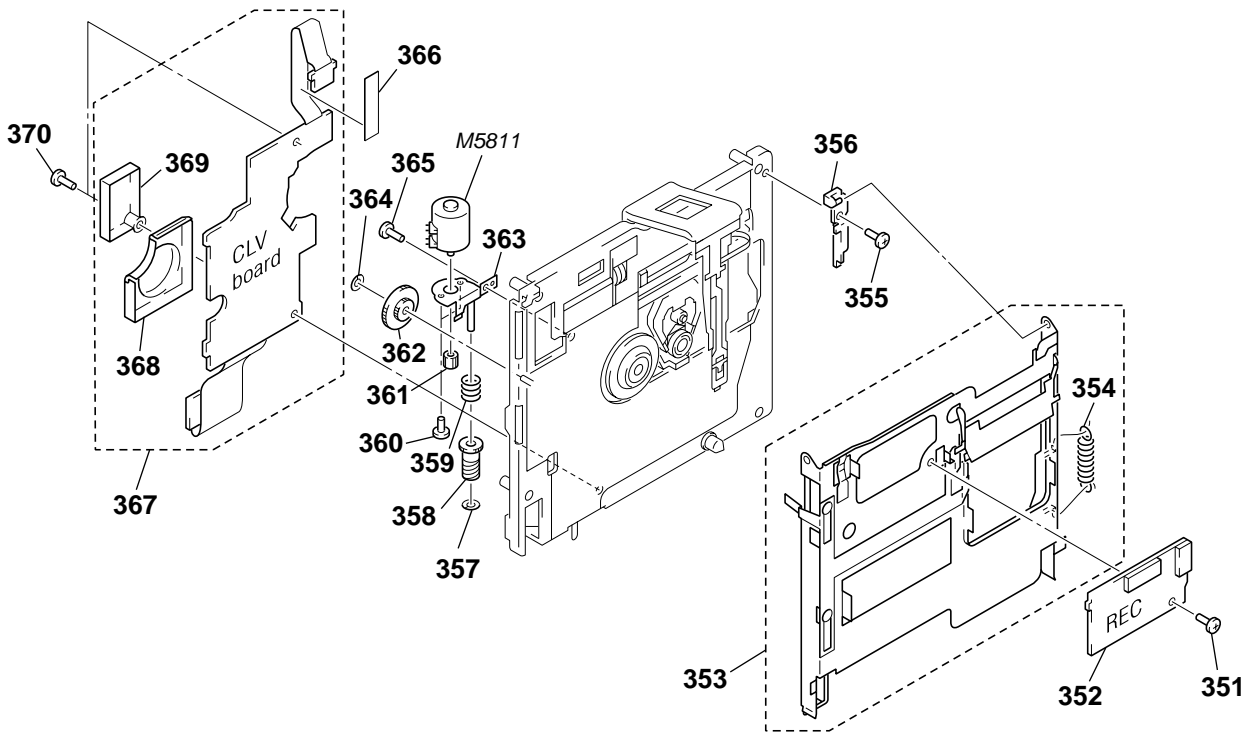

Ref. No.	Part No.	Description	Remark	Ref. No.	Part No.	Description	Remark
351	3-349-825-41	SCREW		362	4-217-948-01	GEAR (WORM WHEEL)	
352	A-3321-863-A	REC BOARD, COMPLETE		363	X-4951-231-1	HOLDER (STEPPER) ASSY	
353	X-4951-230-1	HOLDER ASSY		364	3-338-645-31	WASHER (0.8-2.5)	
354	4-217-955-01	SPRING (POWER TENSION), TENSION		365	4-963-883-01	SCREW (M1.4), PRECISION PAN	
355	4-963-883-41	SCREW (M1.4), PRECISION PAN		366	4-217-958-01	SHEET, ADHESIVE	
356	4-217-946-01	GUIDE, HOLDER		367	A-3323-163-A	CLV BOARD, COMPLETE	
357	3-315-414-41	WASHER		* 368	4-217-952-01	SHIELD (A)	
358	4-217-950-01	GEAR, WORM		* 369	4-217-953-01	SHIELD (B)	
359	4-217-957-01	SPRING (WORM GEAR), COIL		370	4-963-883-21	SCREW (M1.4), PRECISION PAN	
360	4-996-249-01	SCREW (M1.2X1.2)		M5811	1-698-543-21	MOTOR (STEPPING)	
361	4-217-944-01	GEAR (STEPPER)					

**5-9. MECHANISM DECK SECTION-2  
(MT-DCMM1-163)**

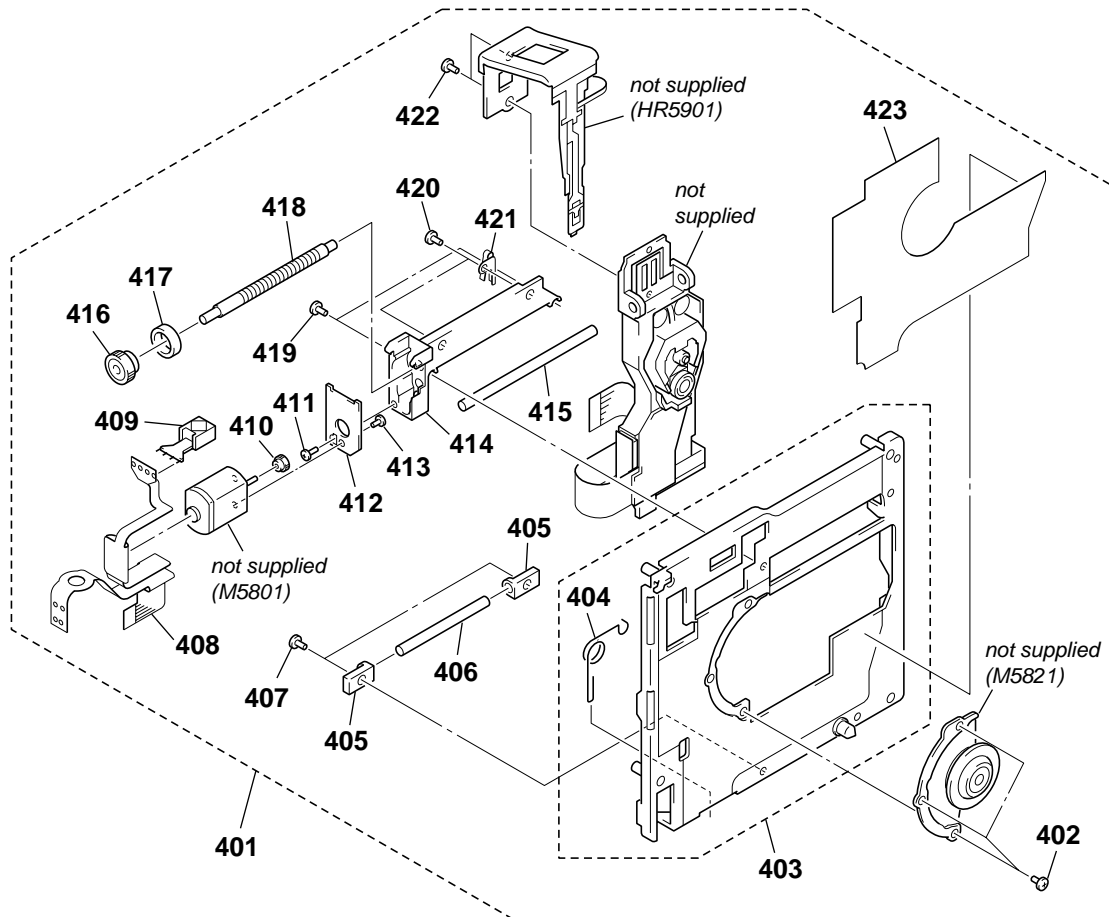

Ref. No.	Part No.	Description	Remark	Ref. No.	Part No.	Description	Remark
401	X-4952-432-1	SERVICE ASSY, OP		413	3-704-246-01	SCREW (P 1.4X1.6)	
402	4-963-883-21	SCREW (M1.4), PRECISION PAN		414	4-217-941-01	BRACKET (LEAD SCREW)	
403	X-4951-229-1	CHASSIS ASSY		* 415	4-217-949-01	SHAFT (MAIN GUIDE)	
404	4-995-585-01	SPRING (LIMITTER), TORSION		416	4-217-927-01	GEAR (B)	
405	4-963-897-01	HOLDER (GUIDE SHAFT)		417	1-452-997-11	ENCODER, MAGNET	
* 406	4-217-956-01	SHAFT (SUB GUIDE)		* 418	4-217-942-01	SCREW, LEAD	
407	3-704-197-33	SCREW (M1.4X3.0), LOCKING		419	4-963-883-81	SCREW (M1.4), PRECISION PAN	
408	1-675-950-11	MOTOR FLEXIBLE BOARD		420	4-963-883-41	SCREW (M1.4), PRECISION PAN	
409	1-418-191-11	SENSOR, MR		421	4-217-947-01	SPRING, THRUST	
410	4-217-928-01	GEAR (A)		422	4-955-841-11	SCREW	
411	4-217-954-01	SCREW (M1.4X4), TAPPING		423	4-217-951-01	COVER, MD	
* 412	4-217-943-01	BRACKET, MOTOR					

## SECTION 6 ELECTRICAL PARTS LIST

BL

CLV

**NOTE:**

- Due to standardization, replacements in the parts list may be different from the parts specified in the diagrams or the components used on the set.
- -XX and -X mean standardized parts, so they may have some difference from the original one.
- **RESISTORS**  
All resistors are in ohms.  
METAL: Metal-film resistor.  
METAL OXIDE: Metal oxide-film resistor.  
F: nonflammable

- Items marked "\*" are not stocked since they are seldom required for routine service. Some delay should be anticipated when ordering these items.
- **SEMICONDUCTORS**  
In each case, u:  $\mu$ , for example:  
uA. . . :  $\mu$ A. . .      uPA. . . :  $\mu$ PA. . .  
uPB. . . :  $\mu$ PB. . .      uPC. . . :  $\mu$ PC. . .  
uPD. . . :  $\mu$ PD. . .
- **CAPACITORS**  
uF:  $\mu$ F
- **COILS**  
uH:  $\mu$ H

The components identified by mark  $\Delta$  or dotted line with mark  $\Delta$  are critical for safety. Replace only with part number specified.

Les composants identifiés par une marque  $\Delta$  sont critiques pour la sécurité. Ne les remplacer que par une pièce portant le numéro spécifié.

When indicating parts by reference number, please include the board.

Ref. No.	Part No.	Description	Remark	Ref. No.	Part No.	Description	Remark
	A-3321-877-A	BL BOARD, COMPLETE ***** (Ref. No.: 20,000 Series)				< CAPACITOR >	
		< CAPACITOR >		C5804	1-164-943-11	CERAMIC CHIP 0.01uF 10% 16V	
				C5805	1-164-943-11	CERAMIC CHIP 0.01uF 10% 16V	
				C5806	1-107-820-11	CERAMIC CHIP 0.1uF 0% 16V	
				C5807	1-164-874-11	CERAMIC CHIP 100PF 5% 16V	
				C5808	1-164-874-11	CERAMIC CHIP 100PF 5% 16V	
C4701	1-162-970-11	CERAMIC CHIP 0.01uF 10% 25V		C5809	1-164-943-11	CERAMIC CHIP 0.01uF 10% 16V	
C4702	1-113-642-11	TANTALUM CHIP 47uF 20% 10V		C5810	1-164-943-11	CERAMIC CHIP 0.01uF 10% 16V	
C4703	1-115-566-11	CERAMIC CHIP 4.7uF 10% 10V		C5811	1-107-820-11	CERAMIC CHIP 0.1uF 0% 16V	
C4704	1-164-677-11	CERAMIC CHIP 0.033uF 10% 16V		C5812	1-107-820-11	CERAMIC CHIP 0.1uF 0% 16V	
$\Delta$ C4706	1-115-464-91	CERAMIC CHIP 0.0022uF 10% 630V		C5813	1-107-820-11	CERAMIC CHIP 0.1uF 0% 16V	
		< CONNECTOR >		C5814	1-107-820-11	CERAMIC CHIP 0.1uF 0% 16V	
CN4701	1-784-421-11	CONNECTOR, FFC/FPC (ZIF) 27P		C5815	1-107-820-11	CERAMIC CHIP 0.1uF 0% 16V	
CN4702	1-691-354-21	CONNECTOR, FFC/FPC (ZIF) 16P		C5816	1-125-777-11	CERAMIC CHIP 0.1uF 10% 10V	
		< DIODE >		C5817	1-113-991-11	TANTALUM CHIP 33uF 20% 16V	
$\Delta$ D4701	8-719-056-49	DIODE 1SS370 (TE85L)		C5818	1-107-820-11	CERAMIC CHIP 0.1uF 0% 16V	
		< COIL >		C5819	1-107-820-11	CERAMIC CHIP 0.1uF 0% 16V	
L4701	1-410-389-31	INDUCTOR CHIP 47uH		C5820	1-113-682-11	TANTALUM CHIP 33uF 20% 10V	
L4702	1-414-398-11	INDUCTOR 10uH		C5823	1-164-939-11	CERAMIC CHIP 0.0022uF 10% 16V	
		< FLUORESCENT INDICATOR >		C5824	1-164-939-11	CERAMIC CHIP 0.0022uF 10% 16V	
$\Delta$ ND4701	1-517-758-11	TUBE, FLUORESCENT (0.55 INCH)		C5825	1-164-939-11	CERAMIC CHIP 0.0022uF 10% 16V	
		< TRANSISTOR >		C5826	1-164-939-11	CERAMIC CHIP 0.0022uF 10% 16V	
$\Delta$ Q4701	8-729-039-24	TRANSISTOR FX216-TL1		C5827	1-164-939-11	CERAMIC CHIP 0.0022uF 10% 16V	
		< RESISTOR >		C5828	1-164-939-11	CERAMIC CHIP 0.0022uF 10% 16V	
R4701	1-218-883-11	METAL CHIP 33K 0.5% 1/16W		C5829	1-113-991-11	TANTALUM CHIP 33uF 20% 16V	
R4702	1-216-809-11	METAL CHIP 100 5% 1/16W		C5851	1-115-566-11	CERAMIC CHIP 4.7uF 10% 10V	
		< TRANSFORMER >		C5852	1-125-777-11	CERAMIC CHIP 0.1uF 10% 10V	
$\Delta$ T4701	1-426-848-51	TRANSFORMER, INVERTER *****		C5853	1-164-870-11	CERAMIC CHIP 68PF 5% 16V	
	A-3323-163-A	CLV BOARD, COMPLETE ***** (Ref. No.: 20,000 Series)		C5854	1-135-070-00	TANTALUM CHIP 0.1uF 10% 35V	
*	4-217-952-01	SHIELD (A)				< CONNECTOR >	
*	4-217-953-01	SHIELD (B)		* CN5801	1-778-158-21	CONNECTOR, FFC/FPC (ZIF) 10P	
				CN5803	1-778-592-21	CONNECTOR, BOARD TO BOARD 50P	
						< DIODE >	
				D5801	8-719-048-98	DIODE RB160L-40TE25	
						< IC >	
				IC5801	8-759-358-40	IC TLC372CPW-E20	
				IC5802	8-759-572-35	IC TLC3702CPWR	
				IC5803	8-759-358-40	IC TLC372CPW-E20	
				IC5804	8-759-082-55	IC TC7W00FU	
				IC5805	8-759-082-57	IC TC7W04FU	

<b>CLV</b>	<b>ETHER</b>
------------	--------------

Ref. No.	Part No.	Description	Remark
IC5806	8-759-082-55	IC TC7W00FU	
IC5807	8-759-572-28	IC NJU7016R	
IC5808	8-759-082-55	IC TC7W00FU	
IC5851	8-759-572-54	IC TA6009FN (EL)	
< COIL >			
L5801	1-416-928-21	INDUCTOR	470uH
< TRANSISTOR >			
Q5801	8-729-047-36	TRANSISTOR	CPH3303-TL
Q5802	8-729-046-70	TRANSISTOR	XP4654- (TX).SO
Q5803	8-729-037-89	TRANSISTOR	2SC4627J-C (TX).SO
Q5808	8-729-037-73	TRANSISTOR	UN9212J- (TX).SO
Q5809	8-729-037-73	TRANSISTOR	UN9212J- (TX).SO
Q5810	8-729-037-73	TRANSISTOR	UN9212J- (TX).SO
Q5811	8-729-037-73	TRANSISTOR	UN9212J- (TX).SO
Q5812	8-729-037-73	TRANSISTOR	UN9212J- (TX).SO
Q5813	8-729-037-73	TRANSISTOR	UN9212J- (TX).SO
Q5821	8-729-044-26	TRANSISTOR	CPH3404-TL
Q5822	8-729-044-26	TRANSISTOR	CPH3404-TL
Q5823	8-729-044-26	TRANSISTOR	CPH3404-TL
Q5824	8-729-044-26	TRANSISTOR	CPH3404-TL
Q5825	8-729-044-26	TRANSISTOR	CPH3404-TL
Q5826	8-729-044-26	TRANSISTOR	CPH3404-TL
< RESISTOR >			
R5801	1-218-965-11	RES, CHIP	10K 5% 1/16W
R5802	1-218-977-11	RES, CHIP	100K 5% 1/16W
R5803	1-218-977-11	RES, CHIP	100K 5% 1/16W
R5804	1-218-965-11	RES, CHIP	10K 5% 1/16W
R5805	1-218-965-11	RES, CHIP	10K 5% 1/16W
R5806	1-218-971-11	RES, CHIP	33K 5% 1/16W
R5807	1-218-953-11	RES, CHIP	1K 5% 1/16W
R5808	1-218-965-11	RES, CHIP	10K 5% 1/16W
R5809	1-218-971-11	RES, CHIP	33K 5% 1/16W
R5810	1-218-953-11	RES, CHIP	1K 5% 1/16W
R5811	1-218-969-11	RES, CHIP	22K 5% 1/16W
R5812	1-218-965-11	RES, CHIP	10K 5% 1/16W
R5813	1-218-977-11	RES, CHIP	100K 5% 1/16W
R5814	1-218-977-11	RES, CHIP	100K 5% 1/16W
R5815	1-218-977-11	RES, CHIP	100K 5% 1/16W
R5816	1-218-977-11	RES, CHIP	100K 5% 1/16W
R5817	1-218-977-11	RES, CHIP	100K 5% 1/16W
R5818	1-218-977-11	RES, CHIP	100K 5% 1/16W
R5819	1-218-965-11	RES, CHIP	10K 5% 1/16W
R5820	1-218-973-11	RES, CHIP	47K 5% 1/16W
R5821	1-218-955-11	RES, CHIP	1.5K 5% 1/16W
R5822	1-218-961-11	RES, CHIP	4.7K 5% 1/16W
R5823	1-218-965-11	RES, CHIP	10K 5% 1/16W
R5824	1-218-965-11	RES, CHIP	10K 5% 1/16W
R5825	1-218-990-11	SHORT	0
R5826	1-218-975-11	RES, CHIP	68K 5% 1/16W
R5827	1-218-975-11	RES, CHIP	68K 5% 1/16W
R5828	1-218-975-11	RES, CHIP	68K 5% 1/16W
R5829	1-218-975-11	RES, CHIP	68K 5% 1/16W
R5830	1-218-975-11	RES, CHIP	68K 5% 1/16W
R5831	1-218-975-11	RES, CHIP	68K 5% 1/16W

Ref. No.	Part No.	Description	Remark
R5832	1-218-965-11	RES, CHIP	10K 5% 1/16W
R5833	1-218-965-11	RES, CHIP	10K 5% 1/16W
R5834	1-218-965-11	RES, CHIP	10K 5% 1/16W
R5851	1-218-967-11	RES, CHIP	15K 5% 1/16W
R5852	1-218-987-11	RES, CHIP	680K 5% 1/16W
< SWITCH >			
S5801	1-692-847-21	SWITCH, PUSH (1 KEY) (PROTECT)	
S5802	1-692-377-31	SWITCH, PUSH (1 KEY) (REFLECT)	
S5803	1-692-377-31	SWITCH, PUSH (1 KEY) (MD1/2)	
S5804	1-572-467-61	SWITCH, PUSH (1 KEY) (INITIAL)	
S5805	1-572-467-61	SWITCH, PUSH (1 KEY) (IN LIMIT)	
< SENSOR >			
SE5851	1-418-203-21	SENSOR, SHOCK (SHOCK SENSOR)	
*****			
A-3323-174-A	ETHER BOARD, COMPLETE		
*****			
(Ref. No.: 20,000 Series)			
3-043-261-01	SHEET, COPY		
3-044-616-01	SHEET, SHIELD		
< CAPACITOR >			
C8801	1-107-820-11	CERAMIC CHIP	0.1uF 0% 16V
C8802	1-104-851-11	TANTALUM CHIP	10uF 20% 10V
C8803	1-107-820-11	CERAMIC CHIP	0.1uF 0% 16V
C8804	1-164-943-11	CERAMIC CHIP	0.01uF 10% 16V
C8805	1-107-820-11	CERAMIC CHIP	0.1uF 0% 16V
C8806	1-107-820-11	CERAMIC CHIP	0.1uF 0% 16V
C8807	1-164-858-11	CERAMIC CHIP	22PF 5% 16V
C8808	1-164-854-11	CERAMIC CHIP	15PF 5% 16V
C8809	1-107-820-11	CERAMIC CHIP	0.1uF 0% 16V
C8810	1-107-820-11	CERAMIC CHIP	0.1uF 0% 16V
C8811	1-107-820-11	CERAMIC CHIP	0.1uF 0% 16V
C8812	1-107-820-11	CERAMIC CHIP	0.1uF 0% 16V
C8813	1-107-820-11	CERAMIC CHIP	0.1uF 0% 16V
C8814	1-107-820-11	CERAMIC CHIP	0.1uF 0% 16V
C8815	1-107-820-11	CERAMIC CHIP	0.1uF 0% 16V
C8816	1-107-820-11	CERAMIC CHIP	0.1uF 0% 16V
C8817	1-107-820-11	CERAMIC CHIP	0.1uF 0% 16V
C8818	1-107-820-11	CERAMIC CHIP	0.1uF 0% 16V
C8819	1-107-820-11	CERAMIC CHIP	0.1uF 0% 16V
C8820	1-164-937-11	CERAMIC CHIP	0.001uF 10% 16V
< CONNECTOR >			
CN8801	1-778-598-21	CONNECTOR, BOARD TO BOARD 60P	
CN8802	1-537-439-41	TARMINAL BOARD, CONNECTOR 20P	
< IC/FILTER >			
IC8801	8-759-573-34	IC 74LVX4245MTCX	
IC8802	8-759-573-34	IC 74LVX4245MTCX	
IC8803	8-759-573-34	IC 74LVX4245MTCX	
IC8804	8-759-573-34	IC 74LVX4245MTCX	
IC8805	8-759-573-34	IC 74LVX4245MTCX	
IC8806	8-759-572-50	IC MB86967PFV-G-BND	
IC8807	1-803-453-11	FILTER MODULE, PCMCIA	
IC8808	8-759-573-35	IC KM62256DLTG-7L	

Ref. No.	Part No.	Description	Remark
		< COIL >	
L8801	1-414-753-91	INDUCTOR 4.7uH	
		< TRANSISTOR >	
Q8801	8-729-047-36	TRANSISTOR CPH3303-TL	
		< RESISTOR >	
R8801	1-218-977-11	RES, CHIP 100K 5% 1/16W	
R8803	1-218-957-11	RES, CHIP 2.2K 5% 1/16W	
		< VIBRATOR >	
X8801	1-781-265-21	VIBRATOR, CRYSTAL (20MHz)	
*****			
	A-3321-883-A	JACK BOARD, COMPLETE	
		*****	
		(Ref. No.: 20,000 Series)	
		< CAPACITOR >	
C1001	1-164-937-11	CERAMIC CHIP 0.001uF 10% 16V	
C1014	1-164-937-11	CERAMIC CHIP 0.001uF 10% 16V	
C2001	1-164-937-11	CERAMIC CHIP 0.001uF 10% 16V	
C2014	1-164-937-11	CERAMIC CHIP 0.001uF 10% 16V	
C3008	1-164-937-11	CERAMIC CHIP 0.001uF 10% 16V	
C3060	1-164-937-11	CERAMIC CHIP 0.001uF 10% 16V	
C3061	1-164-937-11	CERAMIC CHIP 0.001uF 10% 16V	
		< CONNECTOR >	
CN3003	1-778-596-21	CONNECTOR, BOARD TO BOARD 30P	
CN8004	1-778-711-11	CONNECTOR, FFC/FPC (ZIF) 5P	
		< DIODE >	
D1001	8-719-074-62	DIODE MAZS082001SO	
D1002	8-719-074-62	DIODE MAZS082001SO	
D2001	8-719-074-62	DIODE MAZS082001SO	
D2002	8-719-074-62	DIODE MAZS082001SO	
D3001	8-719-074-62	DIODE MAZS082001SO	
D3002	8-719-074-62	DIODE MAZS082001SO	
D3003	8-719-074-62	DIODE MAZS082001SO	
D3004	8-719-074-62	DIODE MAZS082001SO	
D3005	8-719-074-62	DIODE MAZS082001SO	
D3006	8-719-074-62	DIODE MAZS082001SO	
D3007	8-719-074-62	DIODE MAZS082001SO	
D3008	8-719-074-62	DIODE MAZS082001SO	
D4001	8-719-074-62	DIODE MAZS082001SO	
D4002	8-719-074-62	DIODE MAZS082001SO	
D4003	8-719-074-62	DIODE MAZS082001SO	
D4004	8-719-074-62	DIODE MAZS082001SO	
D4005	8-719-074-62	DIODE MAZS082001SO	
D8011	8-719-074-62	DIODE MAZS082001SO	
D8012	8-719-074-62	DIODE MAZS082001SO	
D8013	8-719-074-62	DIODE MAZS082001SO	
		< FERRITE BEAD >	
FB1101	1-469-637-21	FERRITE 0uH	
FB1102	1-469-637-21	FERRITE 0uH	
FB1103	1-469-637-21	FERRITE 0uH	

Ref. No.	Part No.	Description	Remark
FB2101	1-469-637-21	FERRITE 0uH	
FB2102	1-469-637-21	FERRITE 0uH	
FB2103	1-469-637-21	FERRITE 0uH	
FB3001	1-469-637-21	FERRITE 0uH	
FB3002	1-469-637-21	FERRITE 0uH	
FB3003	1-469-637-21	FERRITE 0uH	
FB3101	1-469-637-21	FERRITE 0uH	
		< JACK/CONNECTOR >	
J3001	1-779-881-21	JACK (MIC)	
J3002	1-569-950-21	JACK (S)	
J3003	1-778-040-11	JACK, SMALL TYPE (AUDIO/VIDEO)	
J4001	1-779-870-11	CONNECTOR (ROUND TYPE) 4P (S. VIDEO)	
		< RESISTOR >	
R3051	1-218-990-11	SHORT 0	
R3052	1-218-990-11	SHORT 0	
R3053	1-218-990-11	SHORT 0	
R3055	1-218-990-11	SHORT 0	
R4051	1-216-821-11	METAL CHIP 1K 5% 1/16W	
		< VARISTOR >	
VDR103	1-801-923-11	VARISTOR, CHIP	
VDR203	1-801-923-11	VARISTOR, CHIP	
*****			
	A-3323-169-A	LCD BOARD, COMPLETE	
		*****	
		(Ref. No.: 20,000 Series)	
	4-220-440-01	SHEET (LCD), SHIELD	
		< CAPACITOR >	
C4301	1-125-777-11	CERAMIC CHIP 0.1uF 10% 10V	
C4302	1-117-919-11	TANTALUM CHIP 10uF 20% 6.3V	
C4303	1-117-919-11	TANTALUM CHIP 10uF 20% 6.3V	
C4304	1-119-750-11	TANTALUM CHIP 22uF 20% 6.3V	
C4305	1-125-777-11	CERAMIC CHIP 0.1uF 10% 10V	
C4306	1-125-777-11	CERAMIC CHIP 0.1uF 10% 10V	
C4307	1-117-919-11	TANTALUM CHIP 10uF 20% 6.3V	
C4308	1-104-752-11	TANTALUM CHIP 33uF 20% 6.3V	
C4309	1-164-004-11	CERAMIC CHIP 0.1uF 10% 25V	
C4310	1-119-750-11	TANTALUM CHIP 22uF 20% 6.3V	
C4311	1-125-777-11	CERAMIC CHIP 0.1uF 10% 10V	
C4312	1-135-180-21	TANTALUM CHIP 3.3uF 20% 6.3V	
C4313	1-164-004-11	CERAMIC CHIP 0.1uF 10% 25V	
C4314	1-119-750-11	TANTALUM CHIP 22uF 20% 6.3V	
C4315	1-164-943-11	CERAMIC CHIP 0.01uF 10% 16V	
C4316	1-125-777-11	CERAMIC CHIP 0.1uF 10% 10V	
C4317	1-119-751-11	TANTALUM CHIP 22uF 20% 16V	
C4318	1-164-004-11	CERAMIC CHIP 0.1uF 10% 25V	
C4319	1-125-777-11	CERAMIC CHIP 0.1uF 10% 10V	
C4320	1-164-866-11	CERAMIC CHIP 47PF 5% 16V	
C4321	1-164-882-11	CERAMIC CHIP 220PF 5% 16V	
C4322	1-110-501-11	CERAMIC CHIP 0.33uF 10% 16V	
C4323	1-110-501-11	CERAMIC CHIP 0.33uF 10% 16V	
C4324	1-110-501-11	CERAMIC CHIP 0.33uF 10% 16V	
C4325	1-104-851-11	TANTALUM CHIP 10uF 20% 10V	
C4326	1-125-777-11	CERAMIC CHIP 0.1uF 10% 10V	

LCD

Ref. No.	Part No.	Description	Remark	Ref. No.	Part No.	Description	Remark
C4327	1-117-919-11	TANTALUM CHIP 10uF	20% 6.3V	Q4306	8-729-037-53	TRANSISTOR	2SB1462J-QR (TX).SO
C4328	1-164-004-11	CERAMIC CHIP 0.1uF	10% 25V	Q4307	8-729-037-53	TRANSISTOR	2SB1462J-QR (TX).SO
C4329	1-125-777-11	CERAMIC CHIP 0.1uF	10% 10V	Q4308	8-729-037-53	TRANSISTOR	2SB1462J-QR (TX).SO
C4330	1-110-501-11	CERAMIC CHIP 0.33uF	10% 16V	Q4312	8-729-037-52	TRANSISTOR	2SD2216J-QR (TX).SO
C4331	1-164-870-11	CERAMIC CHIP 68PF	5% 16V	Q4313	8-729-037-53	TRANSISTOR	2SB1462J-QR (TX).SO
C4332	1-164-004-11	CERAMIC CHIP 0.1uF	10% 25V	< RESISTOR >			
C4334	1-164-937-11	CERAMIC CHIP 0.001uF	10% 16V	R4301	1-208-691-11	METAL CHIP	2.2K 0.5% 1/16W
C4335	1-164-862-11	CERAMIC CHIP 33PF	5% 16V	R4302	1-208-675-11	METAL CHIP	470 0.5% 1/16W
C4336	1-164-004-11	CERAMIC CHIP 0.1uF	10% 25V	R4303	1-208-683-11	METAL CHIP	1K 0.5% 1/16W
C4337	1-164-934-11	CERAMIC CHIP 330PF	10% 16V	R4304	1-218-971-11	RES, CHIP	33K 5% 1/16W
C4338	1-125-777-11	CERAMIC CHIP 0.1uF	10% 10V	R4305	1-218-975-11	RES, CHIP	68K 5% 1/16W
C4339	1-125-777-11	CERAMIC CHIP 0.1uF	10% 10V	R4309	1-218-929-11	RES, CHIP	10 5% 1/16W
C4340	1-113-985-11	TANTALUM CHIP 10uF	20% 20V	R4310	1-218-973-11	RES, CHIP	47K 5% 1/16W
C4341	1-109-982-11	CERAMIC CHIP 1uF	10% 10V	R4313	1-218-957-11	RES, CHIP	2.2K 5% 1/16W
C4342	1-113-985-11	TANTALUM CHIP 10uF	20% 20V	R4314	1-218-849-11	METAL CHIP	3.3K 0.5% 1/16W
C4344	1-107-682-11	CERAMIC CHIP 1uF	10% 16V	R4315	1-208-675-11	METAL CHIP	470 0.5% 1/16W
C4345	1-119-751-11	TANTALUM CHIP 22uF	20% 16V	R4316	1-208-683-11	METAL CHIP	1K 0.5% 1/16W
C4346	1-125-777-11	CERAMIC CHIP 0.1uF	10% 10V	R4317	1-218-971-11	RES, CHIP	33K 5% 1/16W
C4352	1-162-964-11	CERAMIC CHIP 0.001uF	10% 50V	R4318	1-218-967-11	RES, CHIP	15K 5% 1/16W
< CONNECTOR >				R4319	1-218-967-11	RES, CHIP	15K 5% 1/16W
* CN4301	1-778-154-21	CONNECTOR, FFC/FPC (ZIF) 6P		R4320	1-218-967-11	RES, CHIP	15K 5% 1/16W
* CN4302	1-785-283-41	PIN, CONNECTOR (PC BOARD) 14P		R4321	1-218-971-11	RES, CHIP	33K 5% 1/16W
CN4303	1-785-283-21	PIN, CONNECTOR (PC BOARD) 14P		R4322	1-218-975-11	RES, CHIP	68K 5% 1/16W
CN4305	1-764-708-21	CONNECTOR, FFC/FPC (LIF) 9P		R4323	1-218-969-11	RES, CHIP	22K 5% 1/16W
* CN4306	1-778-172-11	CONNECTOR, FFC/FPC (ZIF) 24P		R4324	1-218-967-11	RES, CHIP	15K 5% 1/16W
* CN4307	1-569-352-11	HOUSING, CONNECTOR 10P		R4325	1-218-973-11	RES, CHIP	47K 5% 1/16W
< DIODE >				R4326	1-218-967-11	RES, CHIP	15K 5% 1/16W
D4302	8-713-102-80	DIODE 1T369-01-T8A		R4327	1-218-971-11	RES, CHIP	33K 5% 1/16W
D4303	8-713-102-80	DIODE 1T369-01-T8A		R4328	1-218-957-11	RES, CHIP	2.2K 5% 1/16W
D4304	8-719-421-69	DIODE MA133		R4329	1-218-963-11	RES, CHIP	6.8K 5% 1/16W
< FERRITE BEAD >				R4330	1-218-975-11	RES, CHIP	68K 5% 1/16W
FB4301	1-414-445-11	FERRITE 0uH		R4331	1-218-983-11	RES, CHIP	330K 5% 1/16W
< IC >				R4334	1-218-990-11	SHORT	0
IC4301	8-759-596-12	IC AK9813AFS-E2		R4335	1-208-691-11	METAL CHIP	2.2K 0.5% 1/16W
IC4302	8-759-539-27	IC IR3Y37A4		R4336	1-208-675-11	METAL CHIP	470 0.5% 1/16W
IC4303	8-759-524-61	IC CM7018L3-T4		R4337	1-208-683-11	METAL CHIP	1K 0.5% 1/16W
IC4304	8-759-327-01	IC NJM062V (TE2)		R4338	1-218-929-11	RES, CHIP	10 5% 1/16W
< COIL >				R4339	1-218-971-11	RES, CHIP	33K 5% 1/16W
L4301	1-414-754-11	INDUCTOR 10uH		R4340	1-218-975-11	RES, CHIP	68K 5% 1/16W
L4302	1-414-754-11	INDUCTOR 10uH		R4343	1-218-977-11	RES, CHIP	100K 5% 1/16W
L4303	1-414-404-41	INDUCTOR 100uH		R4344	1-218-957-11	RES, CHIP	2.2K 5% 1/16W
L4305	1-414-754-11	INDUCTOR 10uH		R4345	1-218-990-11	SHORT	0
L4306	1-414-754-11	INDUCTOR 10uH		R4347	1-218-965-11	RES, CHIP	10K 5% 1/16W
L4307	1-414-754-11	INDUCTOR 10uH		R4350	1-216-009-91	RES, CHIP	22 5% 1/10W
L4308	1-412-945-11	INDUCTOR 3.3uH		R4351	1-218-990-11	SHORT	0
L4309	1-414-754-11	INDUCTOR 10uH		R4353	1-218-975-11	RES, CHIP	68K 5% 1/16W
< TRANSISTOR >				R4354	1-218-990-11	SHORT	0
Q4301	8-729-044-38	TRANSISTOR SI6552DQ-T1		R4356	1-218-983-11	RES, CHIP	330K 5% 1/16W
Q4302	8-729-044-38	TRANSISTOR SI6552DQ-T1		R4357	1-218-975-11	RES, CHIP	68K 5% 1/16W
Q4303	8-729-037-53	TRANSISTOR 2SB1462J-QR (TX).SO		R4358	1-218-990-11	SHORT	0
Q4304	8-729-037-53	TRANSISTOR 2SB1462J-QR (TX).SO		R4359	1-208-939-11	METAL CHIP	150K 0.5% 1/16W
Q4305	8-729-037-53	TRANSISTOR 2SB1462J-QR (TX).SO		R4360	1-208-955-11	METAL CHIP	680K 0.5% 1/16W
				R4362	1-218-990-11	SHORT	0
				R4366	1-208-931-11	METAL CHIP	68K 0.5% 1/16W
				R4369	1-218-965-11	RES, CHIP	10K 5% 1/16W
				R4370	1-218-989-11	RES, CHIP	1M 5% 1/16W

Ref. No.	Part No.	Description	Remark	Ref. No.	Part No.	Description	Remark
R4371	1-218-975-11	RES, CHIP	68K 5% 1/16W	C1020	1-107-686-11	TANTALUM CHIP 4.7uF 20% 16V	
R4372	1-218-969-11	RES, CHIP	22K 5% 1/16W	C1021	1-125-891-11	CERAMIC CHIP 0.47uF 10% 10V	
R4373	1-218-973-11	RES, CHIP	47K 5% 1/16W	C1022	1-164-939-11	CERAMIC CHIP 0.0022uF 10% 16V	
R4374	1-218-961-11	RES, CHIP	4.7K 5% 1/16W				
R4375	1-218-933-11	RES, CHIP	22 5% 1/16W	C2003	1-163-077-00	CERAMIC CHIP 0.1uF 10% 25V	
				C2004	1-125-891-11	CERAMIC CHIP 0.47uF 10% 10V	
R4376	1-218-975-11	RES, CHIP	68K 5% 1/16W	C2005	1-164-480-11	CERAMIC CHIP 0.01uF 10% 50V	
R4377	1-218-961-11	RES, CHIP	4.7K 5% 1/16W	C2006	1-125-777-11	CERAMIC CHIP 0.1uF 10% 10V	
R4378	1-218-977-11	RES, CHIP	100K 5% 1/16W	C2007	1-164-677-11	CERAMIC CHIP 0.033uF 10% 16V	
R4379	1-218-971-11	RES, CHIP	33K 5% 1/16W				
R4380	1-218-977-11	RES, CHIP	100K 5% 1/16W	C2008	1-162-967-11	CERAMIC CHIP 0.0033uF 10% 50V	
				C2009	1-164-943-11	CERAMIC CHIP 0.01uF 10% 16V	
R4381	1-218-971-11	RES, CHIP	33K 5% 1/16W	C2010	1-164-677-11	CERAMIC CHIP 0.033uF 10% 16V	
R4382	1-218-967-11	RES, CHIP	15K 5% 1/16W	C2011	1-164-677-11	CERAMIC CHIP 0.033uF 10% 16V	
R4383	1-218-965-11	RES, CHIP	10K 5% 1/16W	C2012	1-164-874-11	CERAMIC CHIP 100PF 5% 16V	
R4384	1-218-929-11	RES, CHIP	10 5% 1/16W				
R4385	1-218-929-11	RES, CHIP	10 5% 1/16W	C2013	1-135-337-11	TANTALUM CHIP 1uF 20% 6.3V	
				C2014	1-125-837-91	CERAMIC CHIP 1uF 10% 6.3V	
R4386	1-218-990-11	SHORT	0	C2015	1-135-177-21	TANTALUM CHIP 1uF 20% 20V	
R4387	1-218-937-11	RES, CHIP	47 5% 1/16W	C2016	1-125-837-91	CERAMIC CHIP 1uF 10% 6.3V	
R4388	1-218-937-11	RES, CHIP	47 5% 1/16W	C2017	1-117-919-11	TANTALUM CHIP 10uF 20% 6.3V	
R4389	1-218-937-11	RES, CHIP	47 5% 1/16W				
R4390	1-218-961-11	RES, CHIP	4.7K 5% 1/16W	C2018	1-117-919-11	TANTALUM CHIP 10uF 20% 6.3V	
				C2019	1-164-935-11	CERAMIC CHIP 470PF 10% 16V	
R4391	1-218-977-11	RES, CHIP	100K 5% 1/16W	C2020	1-107-686-11	TANTALUM CHIP 4.7uF 20% 16V	
R4392	1-218-961-11	RES, CHIP	4.7K 5% 1/16W	C2021	1-125-891-11	CERAMIC CHIP 0.47uF 10% 10V	
R4393	1-218-990-11	SHORT	0	C2022	1-164-939-11	CERAMIC CHIP 0.0022uF 10% 16V	
R4394	1-218-990-11	SHORT	0				
R4395	1-218-990-11	SHORT	0	C3001	1-164-937-11	CERAMIC CHIP 0.001uF 10% 16V	
				C3002	1-164-943-11	CERAMIC CHIP 0.01uF 10% 16V	
R4396	1-218-990-11	SHORT	0	C3003	1-135-337-11	TANTALUM CHIP 1uF 20% 6.3V	
R4397	1-218-971-11	RES, CHIP	33K 5% 1/16W	C3004	1-107-820-11	CERAMIC CHIP 0.1uF 0% 16V	
R4400	1-218-990-11	SHORT	0	C3005	1-117-919-11	TANTALUM CHIP 10uF 20% 6.3V	
R4401	1-218-933-11	RES, CHIP	22 5% 1/16W				
R4402	1-208-719-11	METAL CHIP	33K 0.5% 1/16W	C3006	1-107-820-11	CERAMIC CHIP 0.1uF 0% 16V	
				C3007	1-107-820-11	CERAMIC CHIP 0.1uF 0% 16V	
R4403	1-218-961-11	RES, CHIP	4.7K 5% 1/16W	C3008	1-125-891-11	CERAMIC CHIP 0.47uF 10% 10V	
R4405	1-208-711-11	METAL CHIP	15K 0.5% 1/16W	C3011	1-117-919-11	TANTALUM CHIP 10uF 20% 6.3V	
R4407	1-208-707-11	METAL CHIP	10K 0.5% 1/16W	C3013	1-107-820-11	CERAMIC CHIP 0.1uF 0% 16V	
R4408	1-217-671-11	METAL CHIP	1 5% 1/10W				
R4409	1-217-671-11	METAL CHIP	1 5% 1/10W	C3014	1-107-686-11	TANTALUM CHIP 4.7uF 20% 16V	
*****							
A-3323-422-A MAIN BOARD, COMPLETE							
*****							
(Ref. No.: 10,000 Series)							
< CAPACITOR >							
C1003	1-163-077-00	CERAMIC CHIP	0.1uF 10% 25V				
C1004	1-125-891-11	CERAMIC CHIP	0.47uF 10% 10V				
C1005	1-164-480-11	CERAMIC CHIP	0.01uF 10% 50V				
C1006	1-125-777-11	CERAMIC CHIP	0.1uF 10% 10V				
C1007	1-164-677-11	CERAMIC CHIP	0.033uF 10% 16V				
				C3026	1-117-919-11	TANTALUM CHIP 10uF 20% 6.3V	
C1008	1-162-967-11	CERAMIC CHIP	0.0033uF 10% 50V	C3027	1-107-820-11	CERAMIC CHIP 0.1uF 0% 16V	
C1009	1-164-943-11	CERAMIC CHIP	0.01uF 10% 16V	C3028	1-110-569-11	TANTALUM CHIP 47uF 20% 6.3V	
C1010	1-164-677-11	CERAMIC CHIP	0.033uF 10% 16V	C3030	1-119-750-11	TANTALUM CHIP 22uF 20% 6.3V	
C1011	1-164-677-11	CERAMIC CHIP	0.033uF 10% 16V	C3031	1-125-777-11	CERAMIC CHIP 0.1uF 10% 10V	
C1012	1-164-874-11	CERAMIC CHIP	100PF 5% 16V				
				C3032	1-117-919-11	TANTALUM CHIP 10uF 20% 6.3V	
C1013	1-135-337-11	TANTALUM CHIP	1uF 20% 6.3V	C3033	1-135-337-11	TANTALUM CHIP 1uF 20% 6.3V	
C1014	1-125-837-91	CERAMIC CHIP	1uF 10% 6.3V	C3034	1-119-750-11	TANTALUM CHIP 22uF 20% 6.3V	
C1015	1-135-177-21	TANTALUM CHIP	1uF 20% 20V	C3035	1-135-337-11	TANTALUM CHIP 1uF 20% 6.3V	
C1016	1-125-837-91	CERAMIC CHIP	1uF 10% 6.3V	C3036	1-117-919-11	TANTALUM CHIP 10uF 20% 6.3V	
C1017	1-117-919-11	TANTALUM CHIP	10uF 20% 6.3V				
				C3037	1-107-826-91	CERAMIC CHIP 0.1uF 10% 16V	
C1018	1-117-919-11	TANTALUM CHIP	10uF 20% 6.3V	C3038	1-107-826-91	CERAMIC CHIP 0.1uF 10% 16V	
C1019	1-164-935-11	CERAMIC CHIP	470PF 10% 16V	C3039	1-164-874-11	CERAMIC CHIP 100PF 5% 16V	
				C3040	1-125-926-91	TANTALUM CHIP 4.7uF 20% 6.3V	
				C3041	1-107-820-11	CERAMIC CHIP 0.1uF 0% 16V	



**MAIN**

Ref. No.	Part No.	Description	Remark	Ref. No.	Part No.	Description	Remark
C3042	1-107-820-11	CERAMIC CHIP 0.1uF	0% 16V	C5017	1-115-467-11	CERAMIC CHIP 0.22uF	10% 10V
C3043	1-107-820-11	CERAMIC CHIP 0.1uF	0% 16V	C5018	1-164-942-11	CERAMIC CHIP 0.0068uF	10% 16V
C3044	1-117-919-11	TANTALUM CHIP 10uF	20% 6.3V	C5019	1-119-923-81	CERAMIC CHIP 0.047uF	10% 10V
C3045	1-107-820-11	CERAMIC CHIP 0.1uF	0% 16V	C5020	1-164-938-11	CERAMIC CHIP 0.0015uF	10% 16V
C3046	1-107-820-11	CERAMIC CHIP 0.1uF	0% 16V	C5021	1-164-943-11	CERAMIC CHIP 0.01uF	10% 16V
C3047	1-107-820-11	CERAMIC CHIP 0.1uF	0% 16V	C5022	1-125-837-91	CERAMIC CHIP 1uF	10% 6.3V
C3048	1-125-777-11	CERAMIC CHIP 0.1uF	10% 10V	C5023	1-110-563-11	CERAMIC CHIP 0.068uF	10% 16V
C3049	1-107-820-11	CERAMIC CHIP 0.1uF	0% 16V	C5024	1-164-677-11	CERAMIC CHIP 0.033uF	10% 16V
C3050	1-107-820-11	CERAMIC CHIP 0.1uF	0% 16V	C5025	1-107-820-11	CERAMIC CHIP 0.1uF	0% 16V
C3051	1-119-750-11	TANTALUM CHIP 22uF	20% 6.3V	C5026	1-104-851-11	TANTALUM CHIP 10uF	20% 10V
C3052	1-107-820-11	CERAMIC CHIP 0.1uF	0% 16V	C5027	1-107-820-11	CERAMIC CHIP 0.1uF	0% 16V
C3053	1-117-919-11	TANTALUM CHIP 10uF	20% 6.3V	C5028	1-107-820-11	CERAMIC CHIP 0.1uF	0% 16V
C3055	1-164-943-11	CERAMIC CHIP 0.01uF	10% 16V	C5029	1-164-943-11	CERAMIC CHIP 0.01uF	10% 16V
C4001	1-104-851-11	TANTALUM CHIP 10uF	20% 10V	C5030	1-164-943-11	CERAMIC CHIP 0.01uF	10% 16V
C4002	1-104-851-11	TANTALUM CHIP 10uF	20% 10V	C5031	1-125-777-11	CERAMIC CHIP 0.1uF	10% 10V
C4003	1-104-851-11	TANTALUM CHIP 10uF	20% 10V	C5032	1-107-820-11	CERAMIC CHIP 0.1uF	0% 16V
C4004	1-119-749-11	TANTALUM CHIP 33uF	20% 4V	C5033	1-107-820-11	CERAMIC CHIP 0.1uF	0% 16V
C4005	1-125-777-11	CERAMIC CHIP 0.1uF	10% 10V	C5034	1-119-923-81	CERAMIC CHIP 0.047uF	10% 10V
C4006	1-135-181-21	TANTALUM CHIP 4.7uF	20% 6.3V	C5035	1-107-820-11	CERAMIC CHIP 0.1uF	0% 16V
C4007	1-135-181-21	TANTALUM CHIP 4.7uF	20% 6.3V	C5036	1-107-820-11	CERAMIC CHIP 0.1uF	0% 16V
C4008	1-125-777-11	CERAMIC CHIP 0.1uF	10% 10V	C5037	1-107-820-11	CERAMIC CHIP 0.1uF	0% 16V
C4009	1-164-943-11	CERAMIC CHIP 0.01uF	10% 16V	C5038	1-164-943-11	CERAMIC CHIP 0.01uF	10% 16V
C4010	1-125-899-11	TANTALUM CHIP 220uF	20% 4V	C5039	1-119-923-81	CERAMIC CHIP 0.047uF	10% 10V
C4011	1-119-749-11	TANTALUM CHIP 33uF	20% 4V	C5040	1-125-777-11	CERAMIC CHIP 0.1uF	10% 10V
C4012	1-125-777-11	CERAMIC CHIP 0.1uF	10% 10V	C5041	1-107-820-11	CERAMIC CHIP 0.1uF	0% 16V
C4013	1-135-181-21	TANTALUM CHIP 4.7uF	20% 6.3V	C5042	1-164-870-11	CERAMIC CHIP 68PF	5% 16V
C4014	1-135-181-21	TANTALUM CHIP 4.7uF	20% 6.3V	C5043	1-164-862-11	CERAMIC CHIP 33PF	5% 16V
C4015	1-125-777-11	CERAMIC CHIP 0.1uF	10% 10V	C5044	1-125-777-11	CERAMIC CHIP 0.1uF	10% 10V
C4017	1-104-847-11	TANTALUM CHIP 22uF	20% 4V	C5045	1-107-820-11	CERAMIC CHIP 0.1uF	0% 16V
C4018	1-125-899-11	TANTALUM CHIP 220uF	20% 4V	C5046	1-164-870-11	CERAMIC CHIP 68PF	5% 16V
C4019	1-125-777-11	CERAMIC CHIP 0.1uF	10% 10V	C5047	1-164-862-11	CERAMIC CHIP 33PF	5% 16V
C4020	1-125-777-11	CERAMIC CHIP 0.1uF	10% 10V	C5048	1-125-777-11	CERAMIC CHIP 0.1uF	10% 10V
C4021	1-125-777-11	CERAMIC CHIP 0.1uF	10% 10V	C5049	1-107-820-11	CERAMIC CHIP 0.1uF	0% 16V
C4022	1-135-337-11	TANTALUM CHIP 1uF	20% 6.3V	C5051	1-107-820-11	CERAMIC CHIP 0.1uF	0% 16V
C4023	1-107-820-11	CERAMIC CHIP 0.1uF	0% 16V	C5052	1-107-820-11	CERAMIC CHIP 0.1uF	0% 16V
C4024	1-115-467-11	CERAMIC CHIP 0.22uF	10% 10V	C5055	1-125-777-11	CERAMIC CHIP 0.1uF	10% 10V
C4026	1-107-820-11	CERAMIC CHIP 0.1uF	0% 16V	C5056	1-107-819-11	CERAMIC CHIP 0.022uF	10% 16V
C4027	1-107-820-11	CERAMIC CHIP 0.1uF	0% 16V	C5057	1-107-819-11	CERAMIC CHIP 0.022uF	10% 16V
C4028	1-115-467-11	CERAMIC CHIP 0.22uF	10% 10V	C5101	1-125-777-11	CERAMIC CHIP 0.1uF	10% 10V
C4029	1-107-820-11	CERAMIC CHIP 0.1uF	0% 16V	C5102	1-125-837-91	CERAMIC CHIP 1uF	10% 6.3V
C4031	1-107-820-11	CERAMIC CHIP 0.1uF	0% 16V	C5103	1-164-943-11	CERAMIC CHIP 0.01uF	10% 16V
C4032	1-107-820-11	CERAMIC CHIP 0.1uF	0% 16V	C5104	1-164-943-11	CERAMIC CHIP 0.01uF	10% 16V
C5001	1-164-937-11	CERAMIC CHIP 0.001uF	10% 16V	C5105	1-104-851-11	TANTALUM CHIP 10uF	20% 10V
C5002	1-107-820-11	CERAMIC CHIP 0.1uF	0% 16V	C5106	1-107-820-11	CERAMIC CHIP 0.1uF	0% 16V
C5003	1-119-750-11	TANTALUM CHIP 22uF	20% 6.3V	C5201	1-107-826-91	CERAMIC CHIP 0.1uF	10% 16V
C5004	1-107-820-11	CERAMIC CHIP 0.1uF	0% 16V	C5202	1-107-826-91	CERAMIC CHIP 0.1uF	10% 16V
C5005	1-119-750-11	TANTALUM CHIP 22uF	20% 6.3V	C5203	1-107-820-11	CERAMIC CHIP 0.1uF	0% 16V
C5006	1-125-777-11	CERAMIC CHIP 0.1uF	10% 10V	C5204	1-164-850-11	CERAMIC CHIP 10PF	0.5PF 16V
C5007	1-125-777-11	CERAMIC CHIP 0.1uF	10% 10V	C5205	1-164-850-11	CERAMIC CHIP 10PF	0.5PF 16V
C5008	1-164-943-11	CERAMIC CHIP 0.01uF	10% 16V	C5206	1-164-940-11	CERAMIC CHIP 0.0033uF	10% 16V
C5009	1-164-943-11	CERAMIC CHIP 0.01uF	10% 16V	C5207	1-164-940-11	CERAMIC CHIP 0.0033uF	10% 16V
C5011	1-113-985-11	TANTALUM CHIP 10uF	20% 20V	C5208	1-125-777-11	CERAMIC CHIP 0.1uF	10% 10V
C5012	1-125-777-11	CERAMIC CHIP 0.1uF	10% 10V	C5209	1-125-777-11	CERAMIC CHIP 0.1uF	10% 10V
C5013	1-125-777-11	CERAMIC CHIP 0.1uF	10% 10V	C5212	1-107-820-11	CERAMIC CHIP 0.1uF	0% 16V
C5014	1-125-837-91	CERAMIC CHIP 1uF	10% 6.3V	C5301	1-110-569-11	TANTALUM CHIP 47uF	20% 6.3V
C5015	1-107-819-11	CERAMIC CHIP 0.022uF	10% 16V	C5302	1-119-750-11	TANTALUM CHIP 22uF	20% 6.3V
C5016	1-164-943-11	CERAMIC CHIP 0.01uF	10% 16V	C5303	1-107-820-11	CERAMIC CHIP 0.1uF	0% 16V
				C5304	1-125-777-11	CERAMIC CHIP 0.1uF	10% 10V

Ref. No.	Part No.	Description	Remark			Ref. No.	Part No.	Description	Remark		
C5305	1-107-820-11	CERAMIC CHIP	0.1uF	0%	16V	C8008	1-107-820-11	CERAMIC CHIP	0.1uF	0%	16V
C5306	1-125-777-11	CERAMIC CHIP	0.1uF	10%	10V	C8009	1-107-820-11	CERAMIC CHIP	0.1uF	0%	16V
C5307	1-164-847-11	CERAMIC CHIP	7PF	0.5PF	16V	C8010	1-107-820-11	CERAMIC CHIP	0.1uF	0%	16V
C5308	1-164-677-11	CERAMIC CHIP	0.033uF	10%	16V	C8011	1-107-820-11	CERAMIC CHIP	0.1uF	0%	16V
C5309	1-164-847-11	CERAMIC CHIP	7PF	0.5PF	16V	C8012	1-107-820-11	CERAMIC CHIP	0.1uF	0%	16V
C5310	1-125-891-11	CERAMIC CHIP	0.47uF	10%	10V	C8013	1-107-820-11	CERAMIC CHIP	0.1uF	0%	16V
C5311	1-107-820-11	CERAMIC CHIP	0.1uF	0%	16V	C8014	1-107-820-11	CERAMIC CHIP	0.1uF	0%	16V
C5312	1-164-939-11	CERAMIC CHIP	0.0022uF	10%	16V	C8015	1-107-820-11	CERAMIC CHIP	0.1uF	0%	16V
C5313	1-164-874-11	CERAMIC CHIP	100PF	5%	16V	C8016	1-164-935-11	CERAMIC CHIP	470PF	10%	16V
C5314	1-107-820-11	CERAMIC CHIP	0.1uF	0%	16V	C8017	1-164-935-11	CERAMIC CHIP	470PF	10%	16V
C5315	1-125-891-11	CERAMIC CHIP	0.47uF	10%	10V	C8018	1-107-820-11	CERAMIC CHIP	0.1uF	0%	16V
C5316	1-164-943-11	CERAMIC CHIP	0.01uF	10%	16V	C8019	1-107-820-11	CERAMIC CHIP	0.1uF	0%	16V
C5317	1-107-820-11	CERAMIC CHIP	0.1uF	0%	16V	C8020	1-164-858-11	CERAMIC CHIP	22PF	5%	16V
C5318	1-107-820-11	CERAMIC CHIP	0.1uF	0%	16V	C8021	1-164-858-11	CERAMIC CHIP	22PF	5%	16V
C5319	1-107-820-11	CERAMIC CHIP	0.1uF	0%	16V	C8022	1-119-750-11	TANTALUM CHIP	22uF	20%	6.3V
C5401	1-125-777-11	CERAMIC CHIP	0.1uF	10%	10V	C8023	1-107-820-11	CERAMIC CHIP	0.1uF	0%	16V
C5402	1-125-777-11	CERAMIC CHIP	0.1uF	10%	10V	C8024	1-107-820-11	CERAMIC CHIP	0.1uF	0%	16V
C5403	1-107-820-11	CERAMIC CHIP	0.1uF	0%	16V	C8025	1-107-820-11	CERAMIC CHIP	0.1uF	0%	16V
C5404	1-107-820-11	CERAMIC CHIP	0.1uF	0%	16V	C8026	1-164-937-11	CERAMIC CHIP	0.001uF	10%	16V
C5405	1-107-820-11	CERAMIC CHIP	0.1uF	0%	16V	C8027	1-119-750-11	TANTALUM CHIP	22uF	20%	6.3V
C5406	1-107-820-11	CERAMIC CHIP	0.1uF	0%	16V	C8028	1-107-820-11	CERAMIC CHIP	0.1uF	0%	16V
C5407	1-107-820-11	CERAMIC CHIP	0.1uF	0%	16V	C8029	1-107-820-11	CERAMIC CHIP	0.1uF	0%	16V
C5408	1-107-820-11	CERAMIC CHIP	0.1uF	0%	16V	C8030	1-125-891-11	CERAMIC CHIP	0.47uF	10%	10V
C5409	1-164-845-11	CERAMIC CHIP	5PF	0.25PF	16V	C8031	1-107-820-11	CERAMIC CHIP	0.1uF	0%	16V
C5410	1-164-845-11	CERAMIC CHIP	5PF	0.25PF	16V	C8032	1-107-820-11	CERAMIC CHIP	0.1uF	0%	16V
C5411	1-107-820-11	CERAMIC CHIP	0.1uF	0%	16V	C8033	1-107-820-11	CERAMIC CHIP	0.1uF	0%	16V
C5412	1-107-820-11	CERAMIC CHIP	0.1uF	0%	16V	C8034	1-107-820-11	CERAMIC CHIP	0.1uF	0%	16V
C5413	1-107-820-11	CERAMIC CHIP	0.1uF	0%	16V	C8035	1-119-751-11	TANTALUM CHIP	22uF	20%	16V
C5414	1-119-750-11	TANTALUM CHIP	22uF	20%	6.3V	C8036	1-107-820-11	CERAMIC CHIP	0.1uF	0%	16V
C5415	1-107-820-11	CERAMIC CHIP	0.1uF	0%	16V	C8037	1-107-820-11	CERAMIC CHIP	0.1uF	0%	16V
C5417	1-164-845-11	CERAMIC CHIP	5PF	0.25PF	16V	C8038	1-115-565-11	CERAMIC CHIP	2.2uF	10%	10V
C5418	1-164-943-11	CERAMIC CHIP	0.01uF	10%	16V	C8039	1-107-820-11	CERAMIC CHIP	0.1uF	0%	16V
C5419	1-107-820-11	CERAMIC CHIP	0.1uF	0%	16V	C8040	1-107-820-11	CERAMIC CHIP	0.1uF	0%	16V
C5420	1-107-820-11	CERAMIC CHIP	0.1uF	0%	16V	C8041	1-107-820-11	CERAMIC CHIP	0.1uF	0%	16V
C5421	1-164-850-11	CERAMIC CHIP	10PF	0.5PF	16V	C8042	1-107-820-11	CERAMIC CHIP	0.1uF	0%	16V
C5424	1-164-842-11	CERAMIC CHIP	2PF	0.25PF	16V	C8043	1-119-750-11	TANTALUM CHIP	22uF	20%	6.3V
C5501	1-107-820-11	CERAMIC CHIP	0.1uF	0%	16V	C8044	1-107-820-11	CERAMIC CHIP	0.1uF	0%	16V
C5503	1-107-820-11	CERAMIC CHIP	0.1uF	0%	16V	C8045	1-107-820-11	CERAMIC CHIP	0.1uF	0%	16V
C5601	1-125-777-11	CERAMIC CHIP	0.1uF	10%	10V	C8046	1-107-820-11	CERAMIC CHIP	0.1uF	0%	16V
C5602	1-119-751-11	TANTALUM CHIP	22uF	20%	16V	C8047	1-107-820-11	CERAMIC CHIP	0.1uF	0%	16V
C5603	1-107-820-11	CERAMIC CHIP	0.1uF	0%	16V	C8048	1-107-820-11	CERAMIC CHIP	0.1uF	0%	16V
C5604	1-104-912-11	TANTALUM CHIP	3.3uF	20%	16V	C8049	1-107-820-11	CERAMIC CHIP	0.1uF	0%	16V
C5605	1-113-985-11	TANTALUM CHIP	10uF	20%	20V	C8050	1-107-820-11	CERAMIC CHIP	0.1uF	0%	16V
C5606	1-104-912-11	TANTALUM CHIP	3.3uF	20%	16V	C8051	1-107-820-11	CERAMIC CHIP	0.1uF	0%	16V
C5607	1-104-912-11	TANTALUM CHIP	3.3uF	20%	16V	C8052	1-107-820-11	CERAMIC CHIP	0.1uF	0%	16V
C5608	1-104-912-11	TANTALUM CHIP	3.3uF	20%	16V	C8053	1-164-874-11	CERAMIC CHIP	100PF	5%	16V
C5609	1-113-682-11	TANTALUM CHIP	33uF	20%	10V	C8055	1-107-820-11	CERAMIC CHIP	0.1uF	0%	16V
C5610	1-113-682-11	TANTALUM CHIP	33uF	20%	10V	C8056	1-107-820-11	CERAMIC CHIP	0.1uF	0%	16V
C5614	1-113-642-11	TANTALUM CHIP	47uF	20%	10V	C8057	1-125-777-11	CERAMIC CHIP	0.1uF	10%	10V
C5615	1-164-874-11	CERAMIC CHIP	100PF	5%	16V	C8059	1-107-820-11	CERAMIC CHIP	0.1uF	0%	16V
C8001	1-119-750-11	TANTALUM CHIP	22uF	20%	6.3V	C8062	1-125-777-11	CERAMIC CHIP	0.1uF	10%	10V
C8002	1-107-820-11	CERAMIC CHIP	0.1uF	0%	16V	C8063	1-107-820-11	CERAMIC CHIP	0.1uF	0%	16V
C8003	1-164-847-11	CERAMIC CHIP	7PF	0.5PF	16V	C8064	1-107-820-11	CERAMIC CHIP	0.1uF	0%	16V
C8004	1-164-847-11	CERAMIC CHIP	7PF	0.5PF	16V	C8065	1-107-820-11	CERAMIC CHIP	0.1uF	0%	16V
C8005	1-107-820-11	CERAMIC CHIP	0.1uF	0%	16V	C8067	1-107-820-11	CERAMIC CHIP	0.1uF	0%	16V
C8006	1-107-820-11	CERAMIC CHIP	0.1uF	0%	16V	C8068	1-164-845-11	CERAMIC CHIP	5PF	0.25PF	16V
C8007	1-107-820-11	CERAMIC CHIP	0.1uF	0%	16V	C8069	1-107-820-11	CERAMIC CHIP	0.1uF	0%	16V
						C8070	1-119-750-11	TANTALUM CHIP	22uF	20%	6.3V

**MAIN**

Ref. No.	Part No.	Description	Remark	Ref. No.	Part No.	Description	Remark
C8071	1-164-937-11	CERAMIC CHIP 0.001uF 10%	16V	C8608	1-107-820-11	CERAMIC CHIP 0.1uF 0%	16V
C8072	1-107-820-11	CERAMIC CHIP 0.1uF 0%	16V	C8609	1-164-937-11	CERAMIC CHIP 0.001uF 10%	16V
C8073	1-119-750-11	TANTALUM CHIP 22uF 20%	6.3V	C8610	1-107-820-11	CERAMIC CHIP 0.1uF 0%	16V
C8074	1-104-851-11	TANTALUM CHIP 10uF 20%	10V	C8611	1-107-820-11	CERAMIC CHIP 0.1uF 0%	16V
C8075	1-113-985-11	TANTALUM CHIP 10uF 20%	20V	C8612	1-107-820-11	CERAMIC CHIP 0.1uF 0%	16V
C8076	1-119-923-81	CERAMIC CHIP 0.047uF 10%	10V	C8613	1-107-820-11	CERAMIC CHIP 0.1uF 0%	16V
C8077	1-107-820-11	CERAMIC CHIP 0.1uF 0%	16V	C8614	1-107-820-11	CERAMIC CHIP 0.1uF 0%	16V
C8078	1-107-820-11	CERAMIC CHIP 0.1uF 0%	16V	C8615	1-107-820-11	CERAMIC CHIP 0.1uF 0%	16V
C8079	1-107-820-11	CERAMIC CHIP 0.1uF 0%	16V	C8616	1-107-820-11	CERAMIC CHIP 0.1uF 0%	16V
C8080	1-125-777-11	CERAMIC CHIP 0.1uF 10%	10V	C8617	1-107-820-11	CERAMIC CHIP 0.1uF 0%	16V
C8081	1-125-777-11	CERAMIC CHIP 0.1uF 10%	10V	C8618	1-107-820-11	CERAMIC CHIP 0.1uF 0%	16V
C8101	1-119-750-11	TANTALUM CHIP 22uF 20%	6.3V	C8619	1-107-820-11	CERAMIC CHIP 0.1uF 0%	16V
C8102	1-107-820-11	CERAMIC CHIP 0.1uF 0%	16V	C8620	1-107-820-11	CERAMIC CHIP 0.1uF 0%	16V
C8103	1-107-820-11	CERAMIC CHIP 0.1uF 0%	16V	C8621	1-107-820-11	CERAMIC CHIP 0.1uF 0%	16V
C8104	1-107-820-11	CERAMIC CHIP 0.1uF 0%	16V	C8622	1-107-820-11	CERAMIC CHIP 0.1uF 0%	16V
C8105	1-107-820-11	CERAMIC CHIP 0.1uF 0%	16V	C8623	1-107-820-11	CERAMIC CHIP 0.1uF 0%	16V
C8106	1-107-820-11	CERAMIC CHIP 0.1uF 0%	16V	C8624	1-119-750-11	TANTALUM CHIP 22uF 20%	6.3V
C8107	1-107-820-11	CERAMIC CHIP 0.1uF 0%	16V	C8701	1-119-750-11	TANTALUM CHIP 22uF 20%	6.3V
C8108	1-107-820-11	CERAMIC CHIP 0.1uF 0%	16V	C8702	1-107-820-11	CERAMIC CHIP 0.1uF 0%	16V
C8109	1-164-943-11	CERAMIC CHIP 0.01uF 10%	16V	C8703	1-107-820-11	CERAMIC CHIP 0.1uF 0%	16V
C8110	1-107-820-11	CERAMIC CHIP 0.1uF 0%	16V	C8704	1-107-820-11	CERAMIC CHIP 0.1uF 0%	16V
C8111	1-107-820-11	CERAMIC CHIP 0.1uF 0%	16V	C8705	1-107-820-11	CERAMIC CHIP 0.1uF 0%	16V
C8112	1-107-820-11	CERAMIC CHIP 0.1uF 0%	16V	C8706	1-107-820-11	CERAMIC CHIP 0.1uF 0%	16V
C8113	1-107-820-11	CERAMIC CHIP 0.1uF 0%	16V	C8707	1-107-820-11	CERAMIC CHIP 0.1uF 0%	16V
C8114	1-107-820-11	CERAMIC CHIP 0.1uF 0%	16V	C8708	1-107-820-11	CERAMIC CHIP 0.1uF 0%	16V
C8115	1-107-820-11	CERAMIC CHIP 0.1uF 0%	16V	C8709	1-107-820-11	CERAMIC CHIP 0.1uF 0%	16V
C8116	1-107-820-11	CERAMIC CHIP 0.1uF 0%	16V	C8710	1-107-820-11	CERAMIC CHIP 0.1uF 0%	16V
C8117	1-107-820-11	CERAMIC CHIP 0.1uF 0%	16V	C8711	1-107-820-11	CERAMIC CHIP 0.1uF 0%	16V
C8118	1-107-820-11	CERAMIC CHIP 0.1uF 0%	16V	C8712	1-107-820-11	CERAMIC CHIP 0.1uF 0%	16V
C8119	1-107-820-11	CERAMIC CHIP 0.1uF 0%	16V	C8713	1-107-820-11	CERAMIC CHIP 0.1uF 0%	16V
C8120	1-107-820-11	CERAMIC CHIP 0.1uF 0%	16V	C8714	1-107-820-11	CERAMIC CHIP 0.1uF 0%	16V
C8121	1-119-750-11	TANTALUM CHIP 22uF 20%	6.3V	C8715	1-107-820-11	CERAMIC CHIP 0.1uF 0%	16V
C8123	1-107-820-11	CERAMIC CHIP 0.1uF 0%	16V	C8716	1-107-820-11	CERAMIC CHIP 0.1uF 0%	16V
C8126	1-128-964-91	TANTALUM CHIP 100uF 20%	6.3V	C8717	1-107-820-11	CERAMIC CHIP 0.1uF 0%	16V
C8127	1-107-820-11	CERAMIC CHIP 0.1uF 0%	16V	C8718	1-119-750-11	TANTALUM CHIP 22uF 20%	6.3V
C8128	1-107-820-11	CERAMIC CHIP 0.1uF 0%	16V	C9101	1-164-004-11	CERAMIC CHIP 0.1uF 10%	25V
C8129	1-107-820-11	CERAMIC CHIP 0.1uF 0%	16V	C9103	1-107-820-11	CERAMIC CHIP 0.1uF 0%	16V
C8130	1-119-750-11	TANTALUM CHIP 22uF 20%	6.3V	C9104	1-125-777-11	CERAMIC CHIP 0.1uF 10%	10V
C8204	1-125-777-11	CERAMIC CHIP 0.1uF 10%	10V	C9105	1-125-777-11	CERAMIC CHIP 0.1uF 10%	10V
C8208	1-104-851-11	TANTALUM CHIP 10uF 20%	10V	C9106	1-125-777-11	CERAMIC CHIP 0.1uF 10%	10V
C8211	1-117-919-11	TANTALUM CHIP 10uF 20%	6.3V	C9107	1-164-943-11	CERAMIC CHIP 0.01uF 10%	16V
C8501	1-119-750-11	TANTALUM CHIP 22uF 20%	6.3V	C9108	1-125-777-11	CERAMIC CHIP 0.1uF 10%	10V
C8502	1-107-820-11	CERAMIC CHIP 0.1uF 0%	16V	C9109	1-107-820-11	CERAMIC CHIP 0.1uF 0%	16V
C8503	1-107-820-11	CERAMIC CHIP 0.1uF 0%	16V	C9110	1-104-916-11	TANTALUM CHIP 6.8uF 20%	20V
C8504	1-107-820-11	CERAMIC CHIP 0.1uF 0%	16V	C9111	1-104-752-11	TANTALUM CHIP 33uF 20%	6.3V
C8506	1-164-858-11	CERAMIC CHIP 22PF 5%	16V	C9112	1-164-943-11	CERAMIC CHIP 0.01uF 10%	16V
C8507	1-107-820-11	CERAMIC CHIP 0.1uF 0%	16V	C9113	1-125-777-11	CERAMIC CHIP 0.1uF 10%	10V
C8508	1-107-820-11	CERAMIC CHIP 0.1uF 0%	16V	C9114	1-117-919-11	TANTALUM CHIP 10uF 20%	6.3V
C8510	1-107-820-11	CERAMIC CHIP 0.1uF 0%	16V	C9115	1-117-919-11	TANTALUM CHIP 10uF 20%	6.3V
C8511	1-164-858-11	CERAMIC CHIP 22PF 5%	16V	C9116	1-125-777-11	CERAMIC CHIP 0.1uF 10%	10V
C8601	1-119-750-11	TANTALUM CHIP 22uF 20%	6.3V	C9117	1-164-004-11	CERAMIC CHIP 0.1uF 10%	25V
C8602	1-119-750-11	TANTALUM CHIP 22uF 20%	6.3V	C9118	1-107-819-11	CERAMIC CHIP 0.022uF 10%	16V
C8603	1-107-820-11	CERAMIC CHIP 0.1uF 0%	16V	C9119	1-135-213-21	TANTALUM CHIP 3.3uF 20%	25V
C8604	1-107-820-11	CERAMIC CHIP 0.1uF 0%	16V	C9120	1-117-919-11	TANTALUM CHIP 10uF 20%	6.3V
C8605	1-107-820-11	CERAMIC CHIP 0.1uF 0%	16V	C9121	1-117-919-11	TANTALUM CHIP 10uF 20%	6.3V
C8606	1-107-820-11	CERAMIC CHIP 0.1uF 0%	16V	C9122	1-119-750-11	TANTALUM CHIP 22uF 20%	6.3V
C8607	1-107-820-11	CERAMIC CHIP 0.1uF 0%	16V	C9123	1-164-004-11	CERAMIC CHIP 0.1uF 10%	25V
				C9126	1-125-777-11	CERAMIC CHIP 0.1uF 10%	10V

Ref. No.	Part No.	Description	Remark	Ref. No.	Part No.	Description	Remark
C9127	1-117-919-11	TANTALUM CHIP 10uF 20% 6.3V		FB8019	1-469-638-21	FERRITE 0uH	
C9128	1-107-820-11	CERAMIC CHIP 0.1uF 0% 16V		FB8020	1-469-638-21	FERRITE 0uH	
C9129	1-107-820-11	CERAMIC CHIP 0.1uF 0% 16V		FB8021	1-469-637-21	FERRITE 0uH	
C9130	1-107-820-11	CERAMIC CHIP 0.1uF 0% 16V		FB8022	1-469-637-21	FERRITE 0uH	
C9131	1-119-750-11	TANTALUM CHIP 22uF 20% 6.3V				< FILTER >	
C9132	1-107-820-11	CERAMIC CHIP 0.1uF 0% 16V		FL4001	1-233-732-21	FILTER, BAND PASS	
C9133	1-127-772-11	CERAMIC CHIP 0.033uF 10% 16V		FL4002	1-233-733-21	FILTER, LOW PASS	
		< CONNECTOR >		FL5101	1-234-255-21	FILTER, LOW PASS	
CN3001	1-778-507-21	PIN, CONNECTOR (PC BOARD) 4P				< IC >	
CN3002	1-778-591-21	CONNECTOR, BOARD TO BOARD 30P		IC3001	8-759-380-80	IC LA7473V-TLM	
* CN4312	1-785-283-41	PIN, CONNECTOR (PC BOARD) 14P		IC3002	8-759-536-71	IC TLV23621PWR	
CN4313	1-785-283-21	PIN, CONNECTOR (PC BOARD) 14P		IC3003	8-759-488-29	IC TC7W66FU (TE12R)	
CN4511	1-784-651-11	CONNECTOR, FFC/FPC (ZIF) 27P		IC3004	8-759-584-59	IC AK4517A-VQ-L	
CN5001	1-784-422-11	CONNECTOR, FFC/FPC (ZIF) 33P		IC3005	8-759-058-58	IC TC7S04FU (TE85R)	
CN5002	1-778-597-21	CONNECTOR, BOARD TO BOARD 50P		IC3007	8-759-584-58	IC AN7535NSA-E1	
CN8001	1-778-595-21	CONNECTOR, BOARD TO BOARD 20P		IC3008	8-759-649-95	IC LM4881MMX	
CN8002	1-573-916-11	CONNECTOR, FFC/FPC (ZIF) 7P		IC3009	8-752-397-21	IC CXZ31021GA	
CN8003	1-573-915-11	CONNECTOR, FFC/FPC (ZIF) 6P		IC4001	8-759-571-31	IC TK15406M-1TL	
CN8006	1-573-915-11	CONNECTOR, FFC/FPC (ZIF) 6P		IC4002	8-759-571-31	IC TK15406M-1TL	
CN8007	1-778-593-21	CONNECTOR, BOARD TO BOARD 60P		IC4003	8-759-571-32	IC TK15405M-1TL	
CN8101	1-778-803-11	CONNECTOR, BOARD TO BOARD 40P		IC4004	8-759-571-31	IC TK15406M-1TL	
* CN9101	1-785-481-41	CONNECTOR, BOARD TO BOARD 70P		IC4005	8-759-540-53	IC BA7664FV-E2	
		< DIODE >		IC4006	8-759-566-06	IC TC7WH08FU (TE12R)	
D4001	8-719-056-48	DIODE 1SS388 (TPL3)		IC4007	8-759-497-44	IC TC7WH125FU (TE12R)	
D4003	8-719-056-48	DIODE 1SS388 (TPL3)		IC4008	8-759-497-44	IC TC7WH125FU (TE12R)	
D5601	8-719-046-85	DIODE MA2S728		IC4009	8-759-566-06	IC TC7WH08FU (TE12R)	
D5602	8-719-067-36	DIODE MA3ZD1200LS0		IC4010	8-759-497-44	IC TC7WH125FU (TE12R)	
D8001	8-719-046-91	DIODE MA2S111		IC4011	8-759-497-44	IC TC7WH125FU (TE12R)	
D8002	8-719-046-85	DIODE MA2S728		IC5002	8-752-081-97	IC CXA2524R	
D8003	8-719-046-91	DIODE MA2S111		IC5003	8-759-449-58	IC LM7131BCM5X	
D8005	8-719-046-85	DIODE MA2S728		IC5004	8-759-273-87	IC NJM2901V (TE2)	
D8006	8-719-056-48	DIODE 1SS388 (TPL3)		IC5005	8-759-572-28	IC NJU7016R	
D8007	8-719-056-48	DIODE 1SS388 (TPL3)		IC5006	8-759-572-28	IC NJU7016R	
		< FERRITE BEAD >		IC5007	8-759-082-61	IC TC4W53FU	
* FB3001	1-469-092-11	FERRITE 0uH		IC5008	8-759-082-58	IC TC7W08FU	
* FB3002	1-469-092-11	FERRITE 0uH		IC5009	8-759-572-34	IC LMV821M7X	
FB8001	1-469-638-21	FERRITE 0uH		IC5010	8-759-572-34	IC LMV821M7X	
FB8002	1-469-638-21	FERRITE 0uH		IC5011	8-759-572-34	IC LMV821M7X	
FB8003	1-469-638-21	FERRITE 0uH		IC5012	8-759-572-34	IC LMV821M7X	
FB8004	1-469-638-21	FERRITE 0uH		IC5013	8-759-082-55	IC TC7W00FU	
FB8005	1-469-638-21	FERRITE 0uH		IC5014	8-759-082-55	IC TC7W00FU	
FB8006	1-469-638-21	FERRITE 0uH		IC5015	8-759-058-58	IC TC7S04FU (TE85R)	
FB8007	1-469-638-21	FERRITE 0uH		IC5102	8-752-371-18	IC CXD2302Q	
FB8008	1-469-638-21	FERRITE 0uH		IC5201	8-759-572-38	IC NJM2140R	
FB8009	1-469-638-21	FERRITE 0uH		IC5205	8-759-572-35	IC TLC3702CPWR	
FB8010	1-469-638-21	FERRITE 0uH		IC5301	8-752-397-34	IC CXD2652AGA	
FB8011	1-469-638-21	FERRITE 0uH		IC5302	8-759-196-96	IC TC7SH08FU-TE85R	
FB8012	1-469-638-21	FERRITE 0uH		IC5303	8-759-196-96	IC TC7SH08FU-TE85R	
FB8013	1-469-638-21	FERRITE 0uH		IC5401	8-759-572-34	IC LMV821M7X	
FB8014	1-469-638-21	FERRITE 0uH		IC5402	8-759-196-96	IC TC7SH08FU-TE85R	
FB8015	1-469-638-21	FERRITE 0uH		IC5403	8-752-390-38	IC CXD606-112GA	
FB8016	1-469-638-21	FERRITE 0uH		IC5404	8-759-676-88	IC RU6815TC-DCMM1	
FB8017	1-469-638-21	FERRITE 0uH		IC5405	8-759-449-23	IC AK93C55AV-L	
FB8018	1-469-638-21	FERRITE 0uH		IC5406	8-759-559-93	IC S-8110ANP-DSB-T2	
				IC5407	8-759-443-08	IC TC7W241FU-TE12R	
				IC5408	8-759-082-61	IC TC4W53FU	



Ref. No.	Part No.	Description	Remark	Ref. No.	Part No.	Description	Remark
Q8002	8-729-043-94	TRANSISTOR	CPH3106-PM-TL	R1028	1-218-975-11	RES, CHIP	68K 5% 1/16W
Q8003	8-729-044-20	TRANSISTOR	SI6463DQ-T1	R1029	1-218-973-11	RES, CHIP	47K 5% 1/16W
Q8004	8-729-044-20	TRANSISTOR	SI6463DQ-T1	R1030	1-208-675-11	METAL CHIP	470 0.5% 1/16W
Q8005	8-729-037-53	TRANSISTOR	2SB1462J-QR (TX).SO	R1032	1-218-955-11	RES, CHIP	1.5K 5% 1/16W
Q8006	8-729-047-68	TRANSISTOR	SSM3K03FE (TPL3)	R2001	1-218-963-11	RES, CHIP	6.8K 5% 1/16W
Q8007	8-729-044-20	TRANSISTOR	SI6463DQ-T1	R2002	1-218-957-11	RES, CHIP	2.2K 5% 1/16W
Q8008	8-729-044-20	TRANSISTOR	SI6463DQ-T1	R2003	1-218-959-11	RES, CHIP	3.3K 5% 1/16W
Q8009	8-729-047-68	TRANSISTOR	SSM3K03FE (TPL3)	R2004	1-218-947-11	RES, CHIP	330 5% 1/16W
Q8010	8-729-032-62	TRANSISTOR	2SJ347-TE85L	R2005	1-218-965-11	RES, CHIP	10K 5% 1/16W
Q8011	8-729-032-62	TRANSISTOR	2SJ347-TE85L	R2006	1-218-963-11	RES, CHIP	6.8K 5% 1/16W
Q8012	8-729-047-68	TRANSISTOR	SSM3K03FE (TPL3)	R2007	1-218-963-11	RES, CHIP	6.8K 5% 1/16W
Q8013	8-729-047-68	TRANSISTOR	SSM3K03FE (TPL3)	R2008	1-218-971-11	RES, CHIP	33K 5% 1/16W
Q8014	8-729-047-68	TRANSISTOR	SSM3K03FE (TPL3)	R2009	1-218-971-11	RES, CHIP	33K 5% 1/16W
Q9101	8-729-427-72	TRANSISTOR	XP4501	R2010	1-218-969-11	RES, CHIP	22K 5% 1/16W
Q9102	8-729-037-52	TRANSISTOR	2SD2216J-QR (TX).SO	R2011	1-218-971-11	RES, CHIP	33K 5% 1/16W
Q9103	8-729-047-68	TRANSISTOR	SSM3K03FE (TPL3)	R2012	1-218-969-11	RES, CHIP	22K 5% 1/16W
Q9104	8-729-427-70	TRANSISTOR	XP4401	R2013	1-218-961-11	RES, CHIP	4.7K 5% 1/16W
Q9105	8-729-041-23	TRANSISTOR	NDS356AP	R2014	1-218-963-11	RES, CHIP	6.8K 5% 1/16W
Q9107	8-729-047-37	TRANSISTOR	FDN338P	R2015	1-218-973-11	RES, CHIP	47K 5% 1/16W
Q9108	8-729-047-68	TRANSISTOR	SSM3K03FE (TPL3)	R2016	1-208-691-11	METAL CHIP	2.2K 0.5% 1/16W
Q9110	8-729-047-68	TRANSISTOR	SSM3K03FE (TPL3)	R2017	1-208-927-11	METAL CHIP	47K 0.5% 1/16W
Q9111	8-729-427-70	TRANSISTOR	XP4401	R2019	1-218-990-11	SHORT	0
Q9112	8-729-047-68	TRANSISTOR	SSM3K03FE (TPL3)	R2021	1-208-927-11	METAL CHIP	47K 0.5% 1/16W
Q9113	8-729-047-68	TRANSISTOR	SSM3K03FE (TPL3)	R2022	1-218-965-11	RES, CHIP	10K 5% 1/16W
Q9115	8-729-042-82	TRANSISTOR	NDH834P	R2023	1-218-965-11	RES, CHIP	10K 5% 1/16W
Q9116	8-729-047-68	TRANSISTOR	SSM3K03FE (TPL3)	R2024	1-208-927-11	METAL CHIP	47K 0.5% 1/16W
Q9117	8-729-041-23	TRANSISTOR	NDS356AP	R2025	1-218-446-11	METAL CHIP	1 5% 1/16W
Q9122	8-729-047-37	TRANSISTOR	FDN338P	R2026	1-218-990-11	SHORT	0
Q9125	8-729-037-74	TRANSISTOR	UN9213J- (TX).SO	R2027	1-218-849-11	METAL CHIP	3.3K 0.5% 1/16W
Q9126	8-729-032-62	TRANSISTOR	2SJ347-TE85L	R2028	1-218-975-11	RES, CHIP	68K 5% 1/16W
		< RESISTOR >		R2029	1-218-973-11	RES, CHIP	47K 5% 1/16W
R1001	1-218-963-11	RES, CHIP	6.8K 5% 1/16W	R2030	1-208-675-11	METAL CHIP	470 0.5% 1/16W
R1002	1-218-957-11	RES, CHIP	2.2K 5% 1/16W	R2032	1-218-955-11	RES, CHIP	1.5K 5% 1/16W
R1003	1-218-959-11	RES, CHIP	3.3K 5% 1/16W	R3001	1-218-981-11	RES, CHIP	220K 5% 1/16W
R1004	1-218-947-11	RES, CHIP	330 5% 1/16W	R3002	1-216-150-91	RES, CHIP	10 5% 1/8W
R1005	1-218-965-11	RES, CHIP	10K 5% 1/16W	R3004	1-218-977-11	RES, CHIP	100K 5% 1/16W
R1006	1-218-963-11	RES, CHIP	6.8K 5% 1/16W	R3005	1-218-989-11	RES, CHIP	1M 5% 1/16W
R1007	1-218-963-11	RES, CHIP	6.8K 5% 1/16W	R3006	1-218-446-11	METAL CHIP	1 5% 1/16W
R1008	1-218-971-11	RES, CHIP	33K 5% 1/16W	R3009	1-218-965-11	RES, CHIP	10K 5% 1/16W
R1009	1-218-971-11	RES, CHIP	33K 5% 1/16W	R3010	1-218-965-11	RES, CHIP	10K 5% 1/16W
R1010	1-218-969-11	RES, CHIP	22K 5% 1/16W	R3011	1-218-969-11	RES, CHIP	22K 5% 1/16W
R1011	1-218-971-11	RES, CHIP	33K 5% 1/16W	R3013	1-218-979-11	RES, CHIP	150K 5% 1/16W
R1012	1-218-969-11	RES, CHIP	22K 5% 1/16W	R3014	1-218-989-11	RES, CHIP	1M 5% 1/16W
R1013	1-218-961-11	RES, CHIP	4.7K 5% 1/16W	R3015	1-218-989-11	RES, CHIP	1M 5% 1/16W
R1014	1-218-963-11	RES, CHIP	6.8K 5% 1/16W	R3016	1-218-965-11	RES, CHIP	10K 5% 1/16W
R1015	1-218-973-11	RES, CHIP	47K 5% 1/16W	R3018	1-218-975-11	RES, CHIP	68K 5% 1/16W
R1016	1-208-691-11	METAL CHIP	2.2K 0.5% 1/16W	R3019	1-218-969-11	RES, CHIP	22K 5% 1/16W
R1017	1-208-927-11	METAL CHIP	47K 0.5% 1/16W	R3022	1-218-990-11	SHORT	0
R1019	1-218-990-11	SHORT	0	R3023	1-218-983-11	RES, CHIP	330K 5% 1/16W
R1021	1-208-927-11	METAL CHIP	47K 0.5% 1/16W	R4001	1-218-941-11	METAL CHIP	100 0.5% 1/16W
R1022	1-218-965-11	RES, CHIP	10K 5% 1/16W	R4002	1-208-671-11	METAL CHIP	330 0.5% 1/16W
R1023	1-218-965-11	RES, CHIP	10K 5% 1/16W	R4003	1-208-683-11	METAL CHIP	1K 0.5% 1/16W
R1024	1-208-927-11	METAL CHIP	47K 0.5% 1/16W	R4004	1-208-683-11	METAL CHIP	1K 0.5% 1/16W
R1025	1-218-446-11	METAL CHIP	1 5% 1/16W	R4005	1-218-957-11	RES, CHIP	2.2K 5% 1/16W
R1026	1-218-990-11	SHORT	0	R4006	1-218-941-11	METAL CHIP	100 0.5% 1/16W
R1027	1-218-849-11	METAL CHIP	3.3K 0.5% 1/16W	R4007	1-208-671-11	METAL CHIP	330 0.5% 1/16W
				R4008	1-208-683-11	METAL CHIP	1K 0.5% 1/16W
				R4009	1-208-683-11	METAL CHIP	1K 0.5% 1/16W

**MAIN**

Ref. No.	Part No.	Description	Quantity	Unit Price	Remark	Ref. No.	Part No.	Description	Quantity	Unit Price	Remark
R4010	1-218-957-11	RES, CHIP	2.2K	5%	1/16W	R5046	1-218-985-11	RES, CHIP	470K	5%	1/16W
R4011	1-208-675-11	METAL CHIP	470	0.5%	1/16W	R5047	1-218-965-11	RES, CHIP	10K	5%	1/16W
R4012	1-218-941-11	METAL CHIP	100	0.5%	1/16W	R5048	1-218-965-11	RES, CHIP	10K	5%	1/16W
R4013	1-218-957-11	RES, CHIP	2.2K	5%	1/16W	R5049	1-218-973-11	RES, CHIP	47K	5%	1/16W
R4014	1-218-957-11	RES, CHIP	2.2K	5%	1/16W	R5050	1-218-973-11	RES, CHIP	47K	5%	1/16W
R4015	1-218-957-11	RES, CHIP	2.2K	5%	1/16W	R5051	1-218-961-11	RES, CHIP	4.7K	5%	1/16W
R4016	1-218-957-11	RES, CHIP	2.2K	5%	1/16W	R5052	1-218-977-11	RES, CHIP	100K	5%	1/16W
R4017	1-218-957-11	RES, CHIP	2.2K	5%	1/16W	R5053	1-218-977-11	RES, CHIP	100K	5%	1/16W
R4018	1-218-957-11	RES, CHIP	2.2K	5%	1/16W	R5054	1-218-973-11	RES, CHIP	47K	5%	1/16W
R4019	1-218-990-11	SHORT	0			R5055	1-218-977-11	RES, CHIP	100K	5%	1/16W
R4020	1-218-990-11	SHORT	0			R5056	1-218-977-11	RES, CHIP	100K	5%	1/16W
R4021	1-218-990-11	SHORT	0			R5057	1-218-973-11	RES, CHIP	47K	5%	1/16W
R4022	1-218-990-11	SHORT	0			R5058	1-218-977-11	RES, CHIP	100K	5%	1/16W
R4026	1-218-985-11	RES, CHIP	470K	5%	1/16W	R5059	1-218-990-11	SHORT	0		
R4028	1-218-985-11	RES, CHIP	470K	5%	1/16W	R5060	1-218-990-11	SHORT	0		
R4030	1-218-965-11	RES, CHIP	10K	5%	1/16W	R5061	1-218-990-11	SHORT	0		
R4031	1-218-965-11	RES, CHIP	10K	5%	1/16W	R5076	1-218-989-11	RES, CHIP	1M	5%	1/16W
R5001	1-218-945-11	RES, CHIP	220	5%	1/16W	R5077	1-218-989-11	RES, CHIP	1M	5%	1/16W
R5003	1-218-985-11	RES, CHIP	470K	5%	1/16W	R5078	1-218-957-11	RES, CHIP	2.2K	5%	1/16W
R5004	1-218-957-11	RES, CHIP	2.2K	5%	1/16W	R5101	1-218-953-11	RES, CHIP	1K	5%	1/16W
R5005	1-218-957-11	RES, CHIP	2.2K	5%	1/16W	R5102	1-218-953-11	RES, CHIP	1K	5%	1/16W
R5006	1-218-987-11	RES, CHIP	680K	5%	1/16W	R5103	1-218-941-11	RES, CHIP	100	5%	1/16W
R5007	1-218-973-11	RES, CHIP	47K	5%	1/16W	R5104	1-218-953-11	RES, CHIP	1K	5%	1/16W
R5008	1-218-973-11	RES, CHIP	47K	5%	1/16W	R5105	1-218-953-11	RES, CHIP	1K	5%	1/16W
R5009	1-218-953-11	RES, CHIP	1K	5%	1/16W	R5106	1-218-989-11	RES, CHIP	1M	5%	1/16W
R5010	1-218-965-11	RES, CHIP	10K	5%	1/16W	R5107	1-218-989-11	RES, CHIP	1M	5%	1/16W
R5011	1-218-987-11	RES, CHIP	680K	5%	1/16W	R5112	1-218-981-11	RES, CHIP	220K	5%	1/16W
R5012	1-218-977-11	RES, CHIP	100K	5%	1/16W	R5113	1-218-977-11	RES, CHIP	100K	5%	1/16W
R5013	1-218-957-11	RES, CHIP	2.2K	5%	1/16W	R5201	1-218-953-11	RES, CHIP	1K	5%	1/16W
R5014	1-218-977-11	RES, CHIP	100K	5%	1/16W	R5202	1-218-953-11	RES, CHIP	1K	5%	1/16W
R5015	1-218-965-11	RES, CHIP	10K	5%	1/16W	R5203	1-218-953-11	RES, CHIP	1K	5%	1/16W
R5016	1-218-953-11	RES, CHIP	1K	5%	1/16W	R5204	1-218-953-11	RES, CHIP	1K	5%	1/16W
R5017	1-218-949-11	RES, CHIP	470	5%	1/16W	R5205	1-218-971-11	RES, CHIP	33K	5%	1/16W
R5018	1-218-949-11	RES, CHIP	470	5%	1/16W	R5206	1-218-971-11	RES, CHIP	33K	5%	1/16W
R5020	1-218-951-11	RES, CHIP	680	5%	1/16W	R5207	1-218-977-11	RES, CHIP	100K	5%	1/16W
R5021	1-218-951-11	RES, CHIP	680	5%	1/16W	R5208	1-218-977-11	RES, CHIP	100K	5%	1/16W
R5022	1-218-990-11	SHORT	0			R5209	1-218-977-11	RES, CHIP	100K	5%	1/16W
R5023	1-218-953-11	RES, CHIP	1K	5%	1/16W	R5210	1-218-977-11	RES, CHIP	100K	5%	1/16W
R5024	1-218-965-11	RES, CHIP	10K	5%	1/16W	R5211	1-218-981-11	RES, CHIP	220K	5%	1/16W
R5025	1-218-981-11	RES, CHIP	220K	5%	1/16W	R5214	1-218-989-11	RES, CHIP	1M	5%	1/16W
R5026	1-218-977-11	RES, CHIP	100K	5%	1/16W	R5215	1-218-989-11	RES, CHIP	1M	5%	1/16W
R5027	1-218-975-11	RES, CHIP	68K	5%	1/16W	R5216	1-218-990-11	SHORT	0	5%	1/16W
R5028	1-218-965-11	RES, CHIP	10K	5%	1/16W	R5217	1-218-990-11	SHORT	0	5%	1/16W
R5030	1-218-965-11	RES, CHIP	10K	5%	1/16W	R5301	1-218-935-11	RES, CHIP	33	5%	1/16W
R5031	1-218-965-11	RES, CHIP	10K	5%	1/16W	R5302	1-218-959-11	RES, CHIP	3.3K	5%	1/16W
R5032	1-218-977-11	RES, CHIP	100K	5%	1/16W	R5303	1-218-965-11	RES, CHIP	10K	5%	1/16W
R5033	1-218-977-11	RES, CHIP	100K	5%	1/16W	R5304	1-218-971-11	RES, CHIP	33K	5%	1/16W
R5034	1-218-953-11	RES, CHIP	1K	5%	1/16W	R5305	1-218-989-11	RES, CHIP	1M	5%	1/16W
R5037	1-218-985-11	RES, CHIP	470K	5%	1/16W	R5306	1-218-975-11	RES, CHIP	68K	5%	1/16W
R5038	1-218-985-11	RES, CHIP	470K	5%	1/16W	R5307	1-218-975-11	RES, CHIP	68K	5%	1/16W
R5039	1-218-967-11	RES, CHIP	15K	5%	1/16W	R5308	1-218-961-11	RES, CHIP	4.7K	5%	1/16W
R5040	1-218-967-11	RES, CHIP	15K	5%	1/16W	R5309	1-218-985-11	RES, CHIP	470K	5%	1/16W
R5041	1-218-965-11	RES, CHIP	10K	5%	1/16W	R5310	1-218-961-11	RES, CHIP	4.7K	5%	1/16W
R5042	1-218-967-11	RES, CHIP	15K	5%	1/16W	R5311	1-218-977-11	RES, CHIP	100K	5%	1/16W
R5043	1-218-965-11	RES, CHIP	10K	5%	1/16W	R5312	1-218-965-11	RES, CHIP	10K	5%	1/16W
R5044	1-218-985-11	RES, CHIP	470K	5%	1/16W	R5313	1-216-801-11	METAL CHIP	22	5%	1/16W
R5045	1-218-965-11	RES, CHIP	10K	5%	1/16W	R5314	1-218-937-11	RES, CHIP	47	5%	1/16W
						R5316	1-218-959-11	RES, CHIP	3.3K	5%	1/16W

Ref. No.	Part No.	Description	Remark	Ref. No.	Part No.	Description	Remark
R5318	1-218-990-11	SHORT	0	R8023	1-218-953-11	RES, CHIP	1K 5% 1/16W
R5401	1-218-965-11	RES, CHIP	10K 5% 1/16W	R8024	1-218-985-11	RES, CHIP	470K 5% 1/16W
R5402	1-218-965-11	RES, CHIP	10K 5% 1/16W	R8025	1-218-953-11	RES, CHIP	1K 5% 1/16W
R5403	1-218-983-11	RES, CHIP	330K 5% 1/16W	R8026	1-218-985-11	RES, CHIP	470K 5% 1/16W
R5404	1-218-983-11	RES, CHIP	330K 5% 1/16W	R8027	1-218-953-11	RES, CHIP	1K 5% 1/16W
R5405	1-218-983-11	RES, CHIP	330K 5% 1/16W	R8028	1-218-985-11	RES, CHIP	470K 5% 1/16W
R5406	1-218-983-11	RES, CHIP	330K 5% 1/16W	R8029	1-218-953-11	RES, CHIP	1K 5% 1/16W
R5407	1-218-983-11	RES, CHIP	330K 5% 1/16W	R8030	1-218-985-11	RES, CHIP	470K 5% 1/16W
R5408	1-218-983-11	RES, CHIP	330K 5% 1/16W	R8031	1-218-953-11	RES, CHIP	1K 5% 1/16W
R5409	1-208-707-11	METAL CHIP	10K 0.5% 1/16W	R8032	1-218-985-11	RES, CHIP	470K 5% 1/16W
R5410	1-208-719-11	METAL CHIP	33K 0.5% 1/16W	R8033	1-218-953-11	RES, CHIP	1K 5% 1/16W
R5411	1-218-973-11	RES, CHIP	47K 5% 1/16W	R8034	1-218-941-11	RES, CHIP	100 5% 1/16W
R5412	1-218-985-11	RES, CHIP	470K 5% 1/16W	R8035	1-218-941-11	RES, CHIP	100 5% 1/16W
R5413	1-218-983-11	RES, CHIP	330K 5% 1/16W	R8036	1-218-983-11	RES, CHIP	330K 5% 1/16W
R5414	1-218-983-11	RES, CHIP	330K 5% 1/16W	R8037	1-218-965-11	RES, CHIP	10K 5% 1/16W
R5416	1-208-663-11	METAL CHIP	150 0.5% 1/16W	R8038	1-218-953-11	RES, CHIP	1K 5% 1/16W
R5417	1-218-937-11	RES, CHIP	47 5% 1/16W	R8039	1-218-977-11	RES, CHIP	100K 5% 1/16W
R5418	1-218-983-11	RES, CHIP	330K 5% 1/16W	R8040	1-218-985-11	RES, CHIP	470K 5% 1/16W
R5419	1-218-989-11	RES, CHIP	1M 5% 1/16W	R8041	1-218-985-11	RES, CHIP	470K 5% 1/16W
R5420	1-218-939-11	RES, CHIP	68 5% 1/16W	R8042	1-208-955-11	METAL CHIP	680K 0.5% 1/16W
R5421	1-218-989-11	RES, CHIP	1M 5% 1/16W	R8043	1-208-955-11	METAL CHIP	680K 0.5% 1/16W
R5422	1-218-990-11	SHORT	0	R8044	1-218-990-11	SHORT	0
R5423	1-218-990-11	SHORT	0	R8045	1-218-983-11	RES, CHIP	330K 5% 1/16W
R5424	1-218-985-11	RES, CHIP	470K 5% 1/16W	R8046	1-218-961-11	RES, CHIP	4.7K 5% 1/16W
R5425	1-218-990-11	SHORT	0	R8047	1-218-953-11	RES, CHIP	1K 5% 1/16W
R5426	1-218-941-11	METAL CHIP	100 0.5% 1/16W	R8048	1-216-304-11	METAL CHIP	3.3 5% 1/10W
R5427	1-218-941-11	METAL CHIP	100 0.5% 1/16W	R8049	1-216-304-11	METAL CHIP	3.3 5% 1/10W
R5428	1-218-941-11	METAL CHIP	100 0.5% 1/16W	R8050	1-218-941-11	RES, CHIP	100 5% 1/16W
R5429	1-218-941-11	METAL CHIP	100 0.5% 1/16W	R8051	1-218-973-11	RES, CHIP	47K 5% 1/16W
R5601	1-218-990-11	SHORT	0	R8052	1-218-953-11	RES, CHIP	1K 5% 1/16W
R5602	1-218-977-11	RES, CHIP	100K 5% 1/16W	R8053	1-218-983-11	RES, CHIP	330K 5% 1/16W
R5603	1-218-985-11	RES, CHIP	470K 5% 1/16W	R8055	1-218-977-11	RES, CHIP	100K 5% 1/16W
R5604	1-218-989-11	RES, CHIP	1M 5% 1/16W	R8056	1-218-945-11	RES, CHIP	220 5% 1/16W
R5605	1-218-990-11	SHORT	0	R8057	1-218-965-11	RES, CHIP	10K 5% 1/16W
R5606	1-218-983-11	RES, CHIP	330K 5% 1/16W	R8058	1-218-985-11	RES, CHIP	470K 5% 1/16W
R5607	1-218-990-11	SHORT	0	R8061	1-218-989-11	RES, CHIP	1M 5% 1/16W
R8001	1-218-977-11	RES, CHIP	100K 5% 1/16W	R8062	1-218-983-11	RES, CHIP	330K 5% 1/16W
R8002	1-218-953-11	RES, CHIP	1K 5% 1/16W	R8063	1-218-990-11	SHORT	0
R8003	1-218-953-11	RES, CHIP	1K 5% 1/16W	R8064	1-218-990-11	SHORT	0
R8004	1-218-953-11	RES, CHIP	1K 5% 1/16W	R8065	1-218-990-11	SHORT	0
R8005	1-218-953-11	RES, CHIP	1K 5% 1/16W	R8066	1-218-990-11	SHORT	0
R8006	1-218-953-11	RES, CHIP	1K 5% 1/16W	R8067	1-218-990-11	SHORT	0
R8007	1-218-985-11	RES, CHIP	470K 5% 1/16W	R8068	1-218-990-11	SHORT	0
R8008	1-218-985-11	RES, CHIP	470K 5% 1/16W	R8069	1-218-990-11	SHORT	0
R8009	1-218-985-11	RES, CHIP	470K 5% 1/16W	R8070	1-218-990-11	SHORT	0
R8010	1-218-985-11	RES, CHIP	470K 5% 1/16W	R8071	1-218-990-11	SHORT	0
R8011	1-218-985-11	RES, CHIP	470K 5% 1/16W	R8072	1-218-990-11	SHORT	0
R8012	1-218-977-11	RES, CHIP	100K 5% 1/16W	R8073	1-218-990-11	SHORT	0
R8013	1-218-977-11	RES, CHIP	100K 5% 1/16W	R8074	1-218-990-11	SHORT	0
R8015	1-218-985-11	RES, CHIP	470K 5% 1/16W	R8075	1-218-990-11	SHORT	0
R8016	1-218-953-11	RES, CHIP	1K 5% 1/16W	R8076	1-218-990-11	SHORT	0
R8017	1-218-985-11	RES, CHIP	470K 5% 1/16W	R8077	1-218-990-11	SHORT	0
R8018	1-218-953-11	RES, CHIP	1K 5% 1/16W	R8078	1-218-990-11	SHORT	0
R8019	1-218-953-11	RES, CHIP	1K 5% 1/16W	R8079	1-218-990-11	SHORT	0
R8020	1-218-985-11	RES, CHIP	470K 5% 1/16W	R8080	1-218-990-11	SHORT	0
R8021	1-218-953-11	RES, CHIP	1K 5% 1/16W	R8081	1-218-990-11	SHORT	0
R8022	1-218-985-11	RES, CHIP	470K 5% 1/16W	R8082	1-218-990-11	SHORT	0
				R8083	1-218-977-11	RES, CHIP	100K 5% 1/16W



**MAIN**

Ref. No.	Part No.	Description	Remark	Ref. No.	Part No.	Description	Remark
R8084	1-218-990-11	SHORT	0	R8514	1-218-977-11	RES, CHIP	100K 5% 1/16W
R8085	1-218-983-11	RES, CHIP	330K 5% 1/16W	R8515	1-218-977-11	RES, CHIP	100K 5% 1/16W
R8086	1-218-983-11	RES, CHIP	330K 5% 1/16W	R8516	1-218-977-11	RES, CHIP	100K 5% 1/16W
R8087	1-218-983-11	RES, CHIP	330K 5% 1/16W	R8517	1-218-977-11	RES, CHIP	100K 5% 1/16W
R8088	1-218-983-11	RES, CHIP	330K 5% 1/16W	R8519	1-218-977-11	RES, CHIP	100K 5% 1/16W
R8089	1-218-983-11	RES, CHIP	330K 5% 1/16W	R8520	1-218-949-11	RES, CHIP	470 5% 1/16W
R8090	1-218-983-11	RES, CHIP	330K 5% 1/16W	R8521	1-218-977-11	RES, CHIP	100K 5% 1/16W
R8091	1-218-983-11	RES, CHIP	330K 5% 1/16W	R8522	1-218-985-11	RES, CHIP	470K 5% 1/16W
R8092	1-218-983-11	RES, CHIP	330K 5% 1/16W	R8523	1-218-985-11	RES, CHIP	470K 5% 1/16W
R8093	1-218-983-11	RES, CHIP	330K 5% 1/16W	R8524	1-218-989-11	RES, CHIP	1M 5% 1/16W
R8094	1-218-983-11	RES, CHIP	330K 5% 1/16W	R8525	1-218-989-11	RES, CHIP	1M 5% 1/16W
R8095	1-218-983-11	RES, CHIP	330K 5% 1/16W	R8526	1-218-977-11	RES, CHIP	100K 5% 1/16W
R8096	1-218-983-11	RES, CHIP	330K 5% 1/16W	R8527	1-218-985-11	RES, CHIP	470K 5% 1/16W
R8097	1-218-985-11	RES, CHIP	470K 5% 1/16W	R8528	1-218-985-11	RES, CHIP	470K 5% 1/16W
R8098	1-218-953-11	RES, CHIP	1K 5% 1/16W	R8529	1-218-961-11	RES, CHIP	4.7K 5% 1/16W
R8099	1-218-983-11	RES, CHIP	330K 5% 1/16W	R8530	1-218-977-11	RES, CHIP	100K 5% 1/16W
R8101	1-218-945-11	METAL CHIP	220 0.5% 1/16W	R8531	1-218-977-11	RES, CHIP	100K 5% 1/16W
R8102	1-208-671-11	METAL CHIP	330 0.5% 1/16W	R8532	1-218-977-11	RES, CHIP	100K 5% 1/16W
R8103	1-208-679-11	METAL CHIP	680 0.5% 1/16W	R8601	1-218-987-11	RES, CHIP	680K 5% 1/16W
R8104	1-208-683-11	METAL CHIP	1K 0.5% 1/16W	R8602	1-218-990-11	SHORT	0
R8105	1-208-691-11	METAL CHIP	2.2K 0.5% 1/16W	R8603	1-218-990-11	SHORT	0
R8106	1-208-683-11	METAL CHIP	1K 0.5% 1/16W	R8901	1-218-977-11	RES, CHIP	100K 5% 1/16W
R8107	1-218-945-11	METAL CHIP	220 0.5% 1/16W	R8902	1-218-977-11	RES, CHIP	100K 5% 1/16W
R8108	1-218-945-11	METAL CHIP	220 0.5% 1/16W	R8903	1-218-977-11	RES, CHIP	100K 5% 1/16W
R8109	1-218-990-11	SHORT	0	R8904	1-218-990-11	SHORT	0
R8110	1-218-990-11	SHORT	0	R8906	1-218-957-11	RES, CHIP	2.2K 5% 1/16W
R8111	1-218-977-11	RES, CHIP	100K 5% 1/16W	R8908	1-218-977-11	RES, CHIP	100K 5% 1/16W
R8112	1-218-977-11	RES, CHIP	100K 5% 1/16W	R8909	1-218-937-11	RES, CHIP	47 5% 1/16W
R8113	1-218-977-11	RES, CHIP	100K 5% 1/16W	R8910	1-218-959-11	RES, CHIP	3.3K 5% 1/16W
R8114	1-218-977-11	RES, CHIP	100K 5% 1/16W	R8911	1-218-985-11	RES, CHIP	470K 5% 1/16W
R8115	1-218-977-11	RES, CHIP	100K 5% 1/16W	R8912	1-218-965-11	RES, CHIP	10K 5% 1/16W
R8116	1-218-977-11	RES, CHIP	100K 5% 1/16W	R8913	1-218-965-11	RES, CHIP	10K 5% 1/16W
R8117	1-218-977-11	RES, CHIP	100K 5% 1/16W	R8914	1-218-989-11	RES, CHIP	1M 5% 1/16W
R8118	1-218-977-11	RES, CHIP	100K 5% 1/16W	R8915	1-216-304-11	METAL CHIP	3.3 5% 1/10W
R8119	1-218-977-11	RES, CHIP	100K 5% 1/16W	R8916	1-218-949-11	RES, CHIP	470 5% 1/16W
R8120	1-218-977-11	RES, CHIP	100K 5% 1/16W	R8917	1-218-977-11	RES, CHIP	100K 5% 1/16W
R8121	1-218-977-11	RES, CHIP	100K 5% 1/16W	R8918	1-218-965-11	RES, CHIP	10K 5% 1/16W
R8122	1-218-977-11	RES, CHIP	100K 5% 1/16W	R8919	1-218-990-11	SHORT	0
R8125	1-218-990-11	SHORT	0	R8921	1-218-990-11	SHORT	0
R8126	1-218-990-11	SHORT	0	R8931	1-218-967-11	RES, CHIP	15K 5% 1/16W
R8127	1-208-683-11	METAL CHIP	1K 0.5% 1/16W	R8932	1-218-965-11	RES, CHIP	10K 5% 1/16W
R8129	1-218-977-11	RES, CHIP	100K 5% 1/16W	R8933	1-218-989-11	RES, CHIP	1M 5% 1/16W
R8130	1-218-977-11	RES, CHIP	100K 5% 1/16W	R8934	1-218-965-11	RES, CHIP	10K 5% 1/16W
R8208	1-208-679-11	METAL CHIP	680 0.5% 1/16W	R8935	1-218-977-11	RES, CHIP	100K 5% 1/16W
R8501	1-218-961-11	RES, CHIP	4.7K 5% 1/16W	R8936	1-218-959-11	RES, CHIP	3.3K 5% 1/16W
R8502	1-218-961-11	RES, CHIP	4.7K 5% 1/16W	R8937	1-218-989-11	RES, CHIP	1M 5% 1/16W
R8503	1-218-961-11	RES, CHIP	4.7K 5% 1/16W	R9101	1-208-947-11	METAL CHIP	330K 0.5% 1/16W
R8504	1-218-961-11	RES, CHIP	4.7K 5% 1/16W	R9102	1-208-927-11	METAL CHIP	47K 0.5% 1/16W
R8505	1-218-961-11	RES, CHIP	4.7K 5% 1/16W	R9103	1-208-691-11	METAL CHIP	2.2K 0.5% 1/16W
R8506	1-218-961-11	RES, CHIP	4.7K 5% 1/16W	R9104	1-218-969-11	RES, CHIP	22K 5% 1/16W
R8507	1-218-961-11	RES, CHIP	4.7K 5% 1/16W	R9105	1-218-977-11	RES, CHIP	100K 5% 1/16W
R8508	1-218-965-11	RES, CHIP	10K 5% 1/16W	R9106	1-218-989-11	RES, CHIP	1M 5% 1/16W
R8509	1-218-965-11	RES, CHIP	10K 5% 1/16W	R9107	1-218-989-11	RES, CHIP	1M 5% 1/16W
R8510	1-218-965-11	RES, CHIP	10K 5% 1/16W	R9108	1-218-979-11	RES, CHIP	150K 5% 1/16W
R8511	1-218-965-11	RES, CHIP	10K 5% 1/16W	R9109	1-218-990-11	SHORT	0
R8512	1-218-977-11	RES, CHIP	100K 5% 1/16W	R9110	1-218-989-11	RES, CHIP	1M 5% 1/16W
R8513	1-218-977-11	RES, CHIP	100K 5% 1/16W	R9111	1-218-981-11	RES, CHIP	220K 5% 1/16W
				R9112	1-218-977-11	RES, CHIP	100K 5% 1/16W

Ref. No.	Part No.	Description	Remark	Ref. No.	Part No.	Description	Remark
R9113	1-218-989-11	RES, CHIP	1M 5% 1/16W	X5403	1-781-247-21	VIBRATOR, CRYSTAL (70.54MHz)	
R9114	1-218-989-11	RES, CHIP	1M 5% 1/16W	X8001	1-767-994-41	VIBRATOR, CRYSTAL (32.768kHz)	
R9116	1-218-973-11	RES, CHIP	47K 5% 1/16W	X8002	1-767-994-22	VIBRATOR, CRYSTAL (32.768kHz)	
R9117	1-218-990-11	SHORT	0	X8003	1-781-259-21	VIBRATOR, CRYSTAL (9.8304MHz)	
R9118	1-208-947-11	METAL CHIP	330K 0.5% 1/16W	X8501	1-781-260-21	VIBRATOR, CRYSTAL (6.6MHz)	
R9119	1-208-947-11	METAL CHIP	330K 0.5% 1/16W	*****			
R9120	1-218-989-11	RES, CHIP	1M 5% 1/16W	A-3321-881-A	POWER BOARD, COMPLETE		
R9121	1-218-990-11	SHORT	0	*****			
R9123	1-218-977-11	RES, CHIP	100K 5% 1/16W	(Ref. No.: 20,000 Series)			
R9124	1-218-989-11	RES, CHIP	1M 5% 1/16W	3-043-103-01	CUSHION (SHIELD)		
R9125	1-218-989-11	RES, CHIP	1M 5% 1/16W	* 4-216-027-01	CASE (FRONT), SHIELD		
R9126	1-218-977-11	RES, CHIP	100K 5% 1/16W	* 4-216-028-01	CASE (REAR), SHIELD		
R9127	1-218-977-11	RES, CHIP	100K 5% 1/16W	< CAPACITOR >			
R9128	1-218-989-11	RES, CHIP	1M 5% 1/16W	C9001	1-164-937-11	CERAMIC CHIP 0.001uF 10% 16V	
R9129	1-218-989-11	RES, CHIP	1M 5% 1/16W	C9002	1-164-937-11	CERAMIC CHIP 0.001uF 10% 16V	
R9130	1-218-990-11	SHORT	0	C9003	1-164-937-11	CERAMIC CHIP 0.001uF 10% 16V	
R9132	1-218-989-11	RES, CHIP	1M 5% 1/16W	C9004	1-119-751-11	TANTALUM CHIP 22uF 20% 16V	
R9134	1-218-989-11	RES, CHIP	1M 5% 1/16W	C9005	1-119-751-11	TANTALUM CHIP 22uF 20% 16V	
R9135	1-218-989-11	RES, CHIP	1M 5% 1/16W	C9007	1-119-923-81	CERAMIC CHIP 0.047uF 10% 10V	
R9136	1-218-989-11	RES, CHIP	1M 5% 1/16W	C9008	1-107-820-11	CERAMIC CHIP 0.1uF 0% 16V	
R9137	1-218-979-11	RES, CHIP	150K 5% 1/16W	C9009	1-107-820-11	CERAMIC CHIP 0.1uF 0% 16V	
R9139	1-218-989-11	RES, CHIP	1M 5% 1/16W	C9010	1-107-820-11	CERAMIC CHIP 0.1uF 0% 16V	
R9140	1-208-715-11	METAL CHIP	22K 0.5% 1/16W	C9011	1-119-751-11	TANTALUM CHIP 22uF 20% 16V	
R9143	1-218-990-11	SHORT	0	C9012	1-164-938-11	CERAMIC CHIP 0.0015uF 10% 16V	
R9144	1-208-711-11	METAL CHIP	15K 0.5% 1/16W	C9013	1-164-874-11	CERAMIC CHIP 100PF 5% 16V	
R9147	1-218-989-11	RES, CHIP	1M 5% 1/16W	C9014	1-164-489-11	CERAMIC CHIP 0.22uF 10% 16V	
R9148	1-218-990-11	SHORT	0	C9015	1-119-751-11	TANTALUM CHIP 22uF 20% 16V	
R9150	1-218-990-11	SHORT	0	C9017	1-164-942-11	CERAMIC CHIP 0.0068uF 10% 16V	
R9152	1-208-691-11	METAL CHIP	2.2K 0.5% 1/16W	C9018	1-119-751-11	TANTALUM CHIP 22uF 20% 16V	
R9153	1-218-989-11	RES, CHIP	1M 5% 1/16W	C9019	1-164-941-11	CERAMIC CHIP 0.0047uF 10% 16V	
R9154	1-218-989-11	RES, CHIP	1M 5% 1/16W	C9021	1-164-938-11	CERAMIC CHIP 0.0015uF 10% 16V	
R9155	1-208-715-11	METAL CHIP	22K 0.5% 1/16W	C9023	1-164-939-11	CERAMIC CHIP 0.0022uF 10% 16V	
R9156	1-208-927-11	METAL CHIP	47K 0.5% 1/16W	C9024	1-164-938-11	CERAMIC CHIP 0.0015uF 10% 16V	
R9157	1-218-959-11	RES, CHIP	3.3K 5% 1/16W	C9027	1-164-858-11	CERAMIC CHIP 22PF 5% 16V	
R9159	1-208-927-11	METAL CHIP	47K 0.5% 1/16W	C9028	1-164-858-11	CERAMIC CHIP 22PF 5% 16V	
R9161	1-218-989-11	RES, CHIP	1M 5% 1/16W	C9029	1-119-751-11	TANTALUM CHIP 22uF 20% 16V	
R9901	1-218-990-11	SHORT	0	C9030	1-164-935-11	CERAMIC CHIP 470PF 10% 16V	
R9902	1-218-990-11	SHORT	0	C9031	1-164-935-11	CERAMIC CHIP 470PF 10% 16V	
R9903	1-218-990-11	SHORT	0	C9032	1-164-858-11	CERAMIC CHIP 22PF 5% 16V	
R9904	1-218-990-11	SHORT	0	C9033	1-164-935-11	CERAMIC CHIP 470PF 10% 16V	
R9905	1-218-990-11	SHORT	0	C9034	1-164-858-11	CERAMIC CHIP 22PF 5% 16V	
R9906	1-218-990-11	SHORT	0	C9035	1-164-935-11	CERAMIC CHIP 470PF 10% 16V	
R9910	1-218-990-11	SHORT	0	C9036	1-164-935-11	CERAMIC CHIP 470PF 10% 16V	
< SWITCH >				C9037	1-164-935-11	CERAMIC CHIP 470PF 10% 16V	
S8001	1-572-467-61	SWITCH, PUSH (1 KEY)	(OPEN/CLOSE DETECT)	C9038	1-164-858-11	CERAMIC CHIP 22PF 5% 16V	
S8002	1-572-467-61	SWITCH, PUSH (1 KEY)	(HALF LOCK DETECT)	C9039	1-164-858-11	CERAMIC CHIP 22PF 5% 16V	
S8003	1-762-805-21	SWITCH, PUSH (1 KEY)	(OPEN CLOSE DETECT)	C9040	1-119-751-11	TANTALUM CHIP 22uF 20% 16V	
< BATTERY >				C9041	1-119-751-11	TANTALUM CHIP 22uF 20% 16V	
U8001	1-528-834-11	BATTERY, LITHIUM SECONDARY		C9042	1-115-566-11	CERAMIC CHIP 4.7uF 10% 10V	
< VIBRATOR >				C9043	1-115-566-11	CERAMIC CHIP 4.7uF 10% 10V	
X5301	1-767-498-11	OSCILLATOR, CRYSTAL (22.5792MHz)		C9044	1-115-566-11	CERAMIC CHIP 4.7uF 10% 10V	
X5401	1-767-124-11	VIBRATOR, CRYSTAL (16.9344MHz)		C9045	1-115-566-11	CERAMIC CHIP 4.7uF 10% 10V	
				C9046	1-115-566-11	CERAMIC CHIP 4.7uF 10% 10V	
				C9047	1-115-566-11	CERAMIC CHIP 4.7uF 10% 10V	
				C9048	1-104-851-11	TANTALUM CHIP 10uF 20% 10V	
				C9049	1-104-851-11	TANTALUM CHIP 10uF 20% 10V	

# POWER

Ref. No.	Part No.	Description	Remark	Ref. No.	Part No.	Description	Remark
C9050	1-104-851-11	TANTALUM CHIP 10uF	20% 10V			< IC >	
C9051	1-104-852-11	TANTALUM CHIP 22uF	20% 10V				
C9052	1-164-937-11	CERAMIC CHIP 0.001uF	10% 16V	IC9001	8-759-596-54	IC SN104241PM-TEB	
C9053	1-115-339-11	CERAMIC CHIP 0.1uF	10% 50V	IC9002	8-759-252-41	IC TK11900MTL	
C9055	1-104-913-11	TANTALUM CHIP 10uF	20% 16V			< COIL >	
C9057	1-110-569-11	TANTALUM CHIP 47uF	20% 6.3V				
C9059	1-115-339-11	CERAMIC CHIP 0.1uF	10% 50V	L9001	1-409-529-41	INDUCTOR 10uH	
C9061	1-104-852-11	TANTALUM CHIP 22uF	20% 10V	L9002	1-409-529-41	INDUCTOR 10uH	
C9062	1-115-566-11	CERAMIC CHIP 4.7uF	10% 10V	L9003	1-409-529-41	INDUCTOR 10uH	
C9063	1-104-852-11	TANTALUM CHIP 22uF	20% 10V	L9004	1-414-757-11	INDUCTOR 100uH	
C9064	1-104-916-11	TANTALUM CHIP 6.8uF	20% 20V	L9005	1-409-529-41	INDUCTOR 10uH	
C9065	1-104-852-11	TANTALUM CHIP 22uF	20% 10V	L9006	1-424-674-11	INDUCTOR 22uH	
C9066	1-107-820-11	CERAMIC CHIP 0.1uF	0% 16V	L9007	1-409-535-41	INDUCTOR 100uH	
C9067	1-107-820-11	CERAMIC CHIP 0.1uF	0% 16V	L9008	1-409-535-41	INDUCTOR 100uH	
C9068	1-104-916-11	TANTALUM CHIP 6.8uF	20% 20V	L9009	1-409-529-41	INDUCTOR 10uH	
C9069	1-107-820-11	CERAMIC CHIP 0.1uF	0% 16V	L9010	1-409-529-41	INDUCTOR 10uH	
C9070	1-113-994-11	TANTALUM CHIP 6.8uF	20% 16V	L9013	1-469-367-21	INDUCTOR 10uH	
C9071	1-113-994-11	TANTALUM CHIP 6.8uF	20% 16V	L9015	1-414-757-11	INDUCTOR 100uH	
C9072	1-113-984-11	TANTALUM CHIP 1.5uF	20% 35V	L9016	1-414-757-11	INDUCTOR 100uH	
C9073	1-104-752-11	TANTALUM CHIP 33uF	20% 6.3V	L9017	1-469-367-21	INDUCTOR 10uH	
C9074	1-104-916-11	TANTALUM CHIP 6.8uF	20% 20V	L9018	1-469-367-21	INDUCTOR 10uH	
C9076	1-113-682-11	TANTALUM CHIP 33uF	20% 10V	L9019	1-469-367-21	INDUCTOR 10uH	
C9077	1-115-566-11	CERAMIC CHIP 4.7uF	10% 10V	L9020	1-414-757-11	INDUCTOR 100uH	
C9078	1-115-566-11	CERAMIC CHIP 4.7uF	10% 10V	L9021	1-414-757-11	INDUCTOR 100uH	
C9079	1-115-566-11	CERAMIC CHIP 4.7uF	10% 10V	L9022	1-414-757-11	INDUCTOR 100uH	
C9080	1-115-566-11	CERAMIC CHIP 4.7uF	10% 10V	L9023	1-469-367-21	INDUCTOR 10uH	
C9081	1-115-566-11	CERAMIC CHIP 4.7uF	10% 10V			< TRANSISTOR >	
		< CONNECTOR >		Q9001	8-729-804-41	TRANSISTOR 2SB1122-S	
CN9001	1-785-482-41	CONNECTOR, BOARD TO BOARD 70P		Q9002	8-729-037-52	TRANSISTOR 2SD2216J-QR (TX).SO	
* CN9002	1-695-106-11	PIN, CONNECTOR (PC BOARD) 4P		Q9003	8-729-043-94	TRANSISTOR CPH3106-PM-TL	
		< DIODE >		Q9004	8-729-043-94	TRANSISTOR CPH3106-PM-TL	
D9001	8-719-074-63	DIODE MAZS120001SO		Q9005	8-729-043-94	TRANSISTOR CPH3106-PM-TL	
D9002	8-719-074-63	DIODE MAZS120001SO		Q9006	8-729-043-94	TRANSISTOR CPH3106-PM-TL	
D9003	8-719-074-63	DIODE MAZS120001SO		Q9007	8-729-047-38	TRANSISTOR FDN359AN	
D9004	8-719-074-63	DIODE MAZS120001SO		Q9008	8-729-047-38	TRANSISTOR FDN359AN	
D9005	8-719-074-63	DIODE MAZS120001SO		Q9009	8-729-043-94	TRANSISTOR CPH3106-PM-TL	
D9006	8-719-067-36	DIODE MA3ZD1200LSO		Q9010	8-729-427-70	TRANSISTOR XP4401	
D9007	8-719-067-36	DIODE MA3ZD1200LSO				< RESISTOR >	
D9008	8-719-067-36	DIODE MA3ZD1200LSO		R9001	1-208-699-11	METAL CHIP 4.7K 0.5% 1/16W	
D9009	8-719-067-36	DIODE MA3ZD1200LSO		R9003	1-208-707-11	METAL CHIP 10K 0.5% 1/16W	
D9010	8-719-067-36	DIODE MA3ZD1200LSO		R9004	1-218-973-11	RES, CHIP 47K 5% 1/16W	
D9011	8-719-074-63	DIODE MAZS120001SO		R9005	1-218-969-11	RES, CHIP 22K 5% 1/16W	
D9012	8-719-056-48	DIODE 1SS388 (TPL3)		R9006	1-218-973-11	RES, CHIP 47K 5% 1/16W	
D9013	8-719-056-48	DIODE 1SS388 (TPL3)		R9007	1-208-699-11	METAL CHIP 4.7K 0.5% 1/16W	
D9014	8-719-056-48	DIODE 1SS388 (TPL3)		R9008	1-218-967-11	RES, CHIP 15K 5% 1/16W	
D9015	8-719-056-48	DIODE 1SS388 (TPL3)		R9011	1-218-965-11	RES, CHIP 10K 5% 1/16W	
		< FUSE >		R9013	1-218-965-11	RES, CHIP 10K 5% 1/16W	
△ F9001	1-533-760-21	FUSE (SMD) (1.4A/24V)		R9014	1-218-959-11	RES, CHIP 3.3K 5% 1/16W	
△ F9002	1-533-760-21	FUSE (SMD) (1.4A/24V)		R9015	1-218-965-11	RES, CHIP 10K 5% 1/16W	
△ F9003	1-533-760-21	FUSE (SMD) (1.4A/24V)		R9016	1-208-715-11	METAL CHIP 22K 0.5% 1/16W	
△ F9004	1-533-760-21	FUSE (SMD) (1.4A/24V)		R9017	1-208-715-11	METAL CHIP 22K 0.5% 1/16W	
		< FERRITE BEAD >		R9019	1-208-927-11	METAL CHIP 47K 0.5% 1/16W	
* FB9001	1-469-230-21	FERRITE 0uH		R9020	1-218-969-11	RES, CHIP 22K 5% 1/16W	
* FB9002	1-469-230-21	FERRITE 0uH		R9021	1-208-715-11	METAL CHIP 22K 0.5% 1/16W	
				R9022	1-208-703-11	METAL CHIP 6.8K 0.5% 1/16W	
				R9023	1-208-715-11	METAL CHIP 22K 0.5% 1/16W	
				R9024	1-208-715-11	METAL CHIP 22K 0.5% 1/16W	

The components identified by mark △ or dotted line with mark △ are critical for safety. Replace only with part number specified.

Les composants identifiés par une marque △ sont critiques pour la sécurité. Ne les remplacer que par une pièce portant le numéro spécifié.

Ref. No.	Part No.	Description	Remark
R9025	1-208-691-11	METAL CHIP	2.2K 0.5% 1/16W
R9029	1-208-703-11	METAL CHIP	6.8K 0.5% 1/16W
R9031	1-218-965-11	RES, CHIP	10K 5% 1/16W
R9032	1-218-965-11	RES, CHIP	10K 5% 1/16W
R9033	1-208-707-11	METAL CHIP	10K 0.5% 1/16W
R9035	1-208-703-11	METAL CHIP	6.8K 0.5% 1/16W
R9036	1-208-703-11	METAL CHIP	6.8K 0.5% 1/16W
R9037	1-218-849-11	METAL CHIP	3.3K 0.5% 1/16W
R9038	1-218-959-11	RES, CHIP	3.3K 5% 1/16W
R9039	1-218-849-11	METAL CHIP	3.3K 0.5% 1/16W
R9040	1-218-849-11	METAL CHIP	3.3K 0.5% 1/16W
R9041	1-208-683-11	METAL CHIP	1K 0.5% 1/16W
R9042	1-218-975-11	RES, CHIP	68K 5% 1/16W
R9043	1-218-971-11	RES, CHIP	33K 5% 1/16W
R9044	1-218-971-11	RES, CHIP	33K 5% 1/16W
R9045	1-218-965-11	RES, CHIP	10K 5% 1/16W
R9046	1-218-955-11	RES, CHIP	1.5K 5% 1/16W
R9047	1-208-935-11	METAL CHIP	100K 0.5% 1/16W
R9048	1-208-927-11	METAL CHIP	47K 0.5% 1/16W
R9049	1-208-711-11	METAL CHIP	15K 0.5% 1/16W
R9050	1-208-699-11	METAL CHIP	4.7K 0.5% 1/16W
R9051	1-218-969-11	RES, CHIP	22K 5% 1/16W
R9052	1-208-943-11	METAL CHIP	220K 0.5% 1/16W
R9053	1-208-935-11	METAL CHIP	100K 0.5% 1/16W
R9054	1-208-715-11	METAL CHIP	22K 0.5% 1/16W
R9055	1-208-931-11	METAL CHIP	68K 0.5% 1/16W
R9056	1-218-977-11	RES, CHIP	100K 5% 1/16W
R9058	1-208-935-11	METAL CHIP	100K 0.5% 1/16W
R9059	1-208-715-11	METAL CHIP	22K 0.5% 1/16W
R9060	1-218-933-11	RES, CHIP	22 5% 1/16W
R9062	1-218-933-11	RES, CHIP	22 5% 1/16W
R9064	1-218-933-11	RES, CHIP	22 5% 1/16W
R9066	1-219-365-11	SHORT	0
R9067	1-216-296-91	SHORT	0
R9068	1-211-950-11	SHORT	0
< TRANSFORMER >			
<u>△</u> T9001	1-433-623-21	TRANSFORMER, CONVERTER	
*****			
A-3321-863-A	REC BOARD, COMPLETE		
*****			
(Ref. No.: 20,000 Series)			
< CAPACITOR >			
C5901	1-107-820-11	CERAMIC CHIP	0.1uF 0% 16V
C5902	1-117-177-91	CAP-CHIP	33PF 5% 500V
C5903	1-104-851-11	TANTALUM CHIP	10uF 20% 10V
C5904	1-104-851-11	TANTALUM CHIP	10uF 20% 10V
C5905	1-104-851-11	TANTALUM CHIP	10uF 20% 10V
C5906	1-107-820-11	CERAMIC CHIP	0.1uF 0% 16V
< CONNECTOR >			
CN5901	1-778-711-11	CONNECTOR, FFC/FPC (ZIF) 5P	
* CN5902	1-778-158-21	CONNECTOR, FFC/FPC (ZIF) 10P	

Ref. No.	Part No.	Description	Remark
< DIODE >			
D5901	8-719-073-16	DIODE SBE802-TL	
D5902	8-719-073-16	DIODE SBE802-TL	
< IC >			
IC5901	8-759-475-53	IC TC74LCX541FT (EL)	
< TRANSISTOR >			
Q5901	8-729-037-73	TRANSISTOR UN9212J- (TX).SO	
Q5902	8-729-047-35	TRANSISTOR FTD1003-TL	
Q5903	8-729-047-82	TRANSISTOR FTD2007-TL	
< RESISTOR >			
R5901	1-218-983-11	RES, CHIP	330K 5% 1/16W
R5902	1-218-983-11	RES, CHIP	330K 5% 1/16W
R5903	1-218-983-11	RES, CHIP	330K 5% 1/16W
R5904	1-218-983-11	RES, CHIP	330K 5% 1/16W
R5905	1-218-983-11	RES, CHIP	330K 5% 1/16W
*****			
VC-216 BOARD, COMPLETE			
*****			
(Ref. No.: 20,000 Series)			
< CAPACITOR >			
C001	1-104-851-11	TANTALUM CHIP	10uF 20% 10V
C002	1-164-943-11	CERAMIC CHIP	0.01uF 10% 16V
C003	1-164-943-11	CERAMIC CHIP	0.01uF 10% 16V
C004	1-164-850-11	CERAMIC CHIP	10PF 0.5PF 16V
C007	1-107-826-91	CERAMIC CHIP	0.1uF 10% 16V
C008	1-119-750-11	TANTALUM CHIP	22uF 20% 6.3V
C009	1-113-994-11	TANTALUM CHIP	6.8uF 20% 16V
C010	1-107-826-91	CERAMIC CHIP	0.1uF 10% 16V
C011	1-119-750-11	TANTALUM CHIP	22uF 20% 6.3V
C012	1-107-826-91	CERAMIC CHIP	0.1uF 10% 16V
C013	1-165-176-11	CERAMIC CHIP	0.047uF 10% 16V
C014	1-165-176-11	CERAMIC CHIP	0.047uF 10% 16V
C015	1-107-826-91	CERAMIC CHIP	0.1uF 10% 16V
C016	1-165-176-11	CERAMIC CHIP	0.047uF 10% 16V
C017	1-165-176-11	CERAMIC CHIP	0.047uF 10% 16V
C018	1-125-817-11	CERAMIC CHIP	10uF 10% 6.3V
C019	1-125-817-11	CERAMIC CHIP	10uF 10% 6.3V
C020	1-125-817-11	CERAMIC CHIP	10uF 10% 6.3V
C021	1-125-817-11	CERAMIC CHIP	10uF 10% 6.3V
C022	1-110-501-11	CERAMIC CHIP	0.33uF 10% 16V
C023	1-107-826-91	CERAMIC CHIP	0.1uF 10% 16V
C024	1-119-750-11	TANTALUM CHIP	22uF 20% 6.3V
C101	1-164-506-11	CERAMIC CHIP	4.7uF 0% 16V
C102	1-164-506-11	CERAMIC CHIP	4.7uF 0% 16V
C103	1-164-862-11	CERAMIC CHIP	33PF 5% 16V
C104	1-109-982-11	CERAMIC CHIP	1uF 10% 10V
C105	1-164-862-11	CERAMIC CHIP	33PF 5% 16V
C106	1-107-826-91	CERAMIC CHIP	0.1uF 10% 16V
C107	1-119-750-11	TANTALUM CHIP	22uF 20% 6.3V
C108	1-125-839-91	TANTALUM CHIP	47uF 20% 6.3V
C109	1-107-826-91	CERAMIC CHIP	0.1uF 10% 16V
C110	1-107-826-91	CERAMIC CHIP	0.1uF 10% 16V
C111	1-107-826-91	CERAMIC CHIP	0.1uF 10% 16V

The components identified by mark <u>△</u> or dotted line with mark <u>△</u> are critical for safety. Replace only with part number specified.	Les composants identifiés par une marque <u>△</u> sont critiques pour la sécurité. Ne les remplacer que par une pièce portant le numéro spécifié.
--	---

# VC-216

Ref. No.	Part No.	Description			Remark	Ref. No.	Part No.	Description			Remark
C112	1-107-826-91	CERAMIC CHIP	0.1uF	10%	16V			< DIODE >			
C113	1-107-826-91	CERAMIC CHIP	0.1uF	10%	16V						
C114	1-164-943-11	CERAMIC CHIP	0.01uF	10%	16V	D101	8-713-103-84	DIODE	1T379-01-T8A		
C115	1-165-176-11	CERAMIC CHIP	0.047uF	10%	16V	D201	8-719-056-23	DIODE	MA2S111- (K8).SO		
C116	1-165-176-11	CERAMIC CHIP	0.047uF	10%	16V			< FERRITE BEAD >			
C117	1-164-943-11	CERAMIC CHIP	0.01uF	10%	16V						
C118	1-107-826-91	CERAMIC CHIP	0.1uF	10%	16V	FB101	1-414-228-11	FERRITE	0uH		
						FB102	1-500-284-21	FERRITE	0uH		
C119	1-164-846-11	CERAMIC CHIP	6PF	0.5PF	16V	FB103	1-414-228-11	FERRITE	0uH		
C120	1-107-826-91	CERAMIC CHIP	0.1uF	10%	16V	FB104	1-414-228-11	FERRITE	0uH		
C121	1-164-943-11	CERAMIC CHIP	0.01uF	10%	16V	FB105	1-414-228-11	FERRITE	0uH		
C123	1-107-826-91	CERAMIC CHIP	0.1uF	10%	16V						
C124	1-107-826-91	CERAMIC CHIP	0.1uF	10%	16V	FB201	1-414-228-11	FERRITE	0uH		
								< IC >			
C125	1-125-837-91	CERAMIC CHIP	1uF	10%	6.3V	IC002	8-759-489-19	IC	uPC6756GR-8JG-E2		
C126	1-107-826-91	CERAMIC CHIP	0.1uF	10%	16V	IC101	8-752-386-72	IC	CXD2444R		
C127	1-107-826-91	CERAMIC CHIP	0.1uF	10%	16V	IC102	8-759-570-81	IC	AD9808AJSTR		
C128	1-117-919-11	TANTALUM CHIP	10uF	20%	6.3V	IC103	8-759-445-93	IC	AK6440AM-E2		
C129	1-119-750-11	TANTALUM CHIP	22uF	20%	6.3V	IC104	8-759-387-31	IC	TC75S55F (TE85R)		
C130	1-107-826-91	CERAMIC CHIP	0.1uF	10%	16V	IC105	8-759-497-43	IC	CXD8691R-TEB		
C131	1-107-826-91	CERAMIC CHIP	0.1uF	10%	16V	IC106	8-752-904-85	IC	CXP912032-098R-T6		
C132	1-125-837-91	CERAMIC CHIP	1uF	10%	6.3V	IC201	8-759-444-87	IC	NJM324V (TE2)		
C133	1-165-176-11	CERAMIC CHIP	0.047uF	10%	16V	IC202	8-759-492-31	IC	MPC17A134VMEL		
C134	1-117-920-11	TANTALUM CHIP	10uF	20%	6.3V			< COIL >			
C135	1-107-826-91	CERAMIC CHIP	0.1uF	10%	16V	L001	1-414-757-11	INDUCTOR	100uH		
C136	1-164-943-11	CERAMIC CHIP	0.01uF	10%	16V	L002	1-414-754-11	INDUCTOR	10uH		
C137	1-117-920-11	TANTALUM CHIP	10uF	20%	6.3V	L101	1-414-754-11	INDUCTOR	10uH		
C138	1-107-826-91	CERAMIC CHIP	0.1uF	10%	16V	L103	1-414-754-11	INDUCTOR	10uH		
C139	1-164-943-11	CERAMIC CHIP	0.01uF	10%	16V	L104	1-414-754-11	INDUCTOR	10uH		
C140	1-164-943-11	CERAMIC CHIP	0.01uF	10%	16V						
C141	1-107-826-91	CERAMIC CHIP	0.1uF	10%	16V	L201	1-414-754-11	INDUCTOR	10uH		
C142	1-109-982-11	CERAMIC CHIP	1uF	10%	10V	L202	1-414-754-11	INDUCTOR	10uH		
C143	1-164-850-11	CERAMIC CHIP	10PF	0.5PF	16V	L203	1-414-754-11	INDUCTOR	10uH		
C201	1-164-943-11	CERAMIC CHIP	0.01uF	10%	16V			< TRANSISTOR >			
C202	1-164-941-11	CERAMIC CHIP	0.0047uF	10%	16V	Q001	8-729-117-73	TRANSISTOR	2SC4178-F14		
C203	1-107-826-91	CERAMIC CHIP	0.1uF	10%	16V	Q101	8-729-037-61	TRANSISTOR	UN9113J- (TX).SO		
C204	1-107-826-91	CERAMIC CHIP	0.1uF	10%	16V	Q102	8-729-037-74	TRANSISTOR	UN9213J- (TX).SO		
C205	1-164-935-11	CERAMIC CHIP	470PF	10%	16V	Q103	8-729-037-61	TRANSISTOR	UN9113J- (TX).SO		
C206	1-164-489-11	CERAMIC CHIP	0.22uF	10%	16V	Q104	8-729-037-74	TRANSISTOR	UN9213J- (TX).SO		
C207	1-164-937-11	CERAMIC CHIP	0.001uF	10%	16V	Q201	8-729-037-53	TRANSISTOR	2SB1462J-QR (TX).SO		
C208	1-107-823-11	CERAMIC CHIP	0.47uF	10%	16V	Q202	8-729-037-52	TRANSISTOR	2SD2216J-QR (TX).SO		
C209	1-164-943-11	CERAMIC CHIP	0.01uF	10%	16V	Q203	8-729-037-53	TRANSISTOR	2SB1462J-QR (TX).SO		
C210	1-164-943-11	CERAMIC CHIP	0.01uF	10%	16V	Q204	8-729-037-52	TRANSISTOR	2SD2216J-QR (TX).SO		
C211	1-164-943-11	CERAMIC CHIP	0.01uF	10%	16V			< RESISTOR/FILTER >			
C212	1-164-939-11	CERAMIC CHIP	0.0022uF	10%	16V	R005	1-218-959-11	RES, CHIP	3.3K	5%	1/16W
C213	1-164-943-11	CERAMIC CHIP	0.01uF	10%	16V	R007	1-218-969-11	RES, CHIP	22K	5%	1/16W
C214	1-107-826-91	CERAMIC CHIP	0.1uF	10%	16V	R008	1-218-933-11	RES, CHIP	22	5%	1/16W
C215	1-117-920-11	TANTALUM CHIP	10uF	20%	6.3V	R009	1-218-969-11	RES, CHIP	22K	5%	1/16W
C216	1-164-943-11	CERAMIC CHIP	0.01uF	10%	16V	R010	1-218-969-11	RES, CHIP	22K	5%	1/16W
C217	1-107-826-91	CERAMIC CHIP	0.1uF	10%	16V	R011	1-218-969-11	RES, CHIP	22K	5%	1/16W
C218	1-107-826-91	CERAMIC CHIP	0.1uF	10%	16V	R012	1-218-965-11	RES, CHIP	10K	5%	1/16W
C219	1-119-750-11	TANTALUM CHIP	22uF	20%	6.3V	R013	1-218-965-11	RES, CHIP	10K	5%	1/16W
C220	1-164-943-11	CERAMIC CHIP	0.01uF	10%	16V	R014	1-218-989-11	RES, CHIP	1M	5%	1/16W
C221	1-125-839-91	TANTALUM CHIP	47uF	20%	6.3V	R015	1-218-967-11	RES, CHIP	15K	5%	1/16W
C222	1-119-750-11	TANTALUM CHIP	22uF	20%	6.3V	R016	1-218-989-11	RES, CHIP	1M	5%	1/16W
		< CONNECTOR >				R101	1-469-537-21	FILTER	0uH		
CN101	1-778-804-11	CONNECTOR, BOARD TO BOARD 40P									
CN201	1-766-354-21	CONNECTOR, FFC/FPC 24P									

Ref. No.	Part No.	Description	Remark	Ref. No.	Part No.	Description	Remark
R102	1-469-537-21	FILTER	0uH	R224	1-218-973-11	RES, CHIP	47K 5% 1/16W
R103	1-218-933-11	RES, CHIP	22 5% 1/16W	R225	1-216-864-11	METAL CHIP	0 5% 1/16W
R104	1-218-977-11	RES, CHIP	100K 5% 1/16W	R226	1-216-864-11	METAL CHIP	0 5% 1/16W
R105	1-218-945-11	RES, CHIP	220 5% 1/16W	< SENSOR >			
R106	1-218-977-11	RES, CHIP	100K 5% 1/16W	SE001	1-803-042-41	SENSOR, ANGULAR VELOCITY (YAW SENSOR)	
R107	1-218-990-11	SHORT	0	SE201	1-803-042-31	SENSOR, ANGULAR VELOCITY (PITCH SENSOR)	
R108	1-218-985-11	RES, CHIP	470K 5% 1/16W	< VIBRATOR >			
R109	1-218-983-11	RES, CHIP	330K 5% 1/16W	X101	1-767-203-21	VIBRATOR, CRYSTAL (36MHz)	
R110	1-218-953-11	RES, CHIP	1K 5% 1/16W	X102	1-767-980-21	VIBRATOR, CERAMIC (20MHz)	
R111	1-218-973-11	RES, CHIP	47K 5% 1/16W	*****			
R112	1-218-973-11	RES, CHIP	47K 5% 1/16W	A-3321-879-A	VF BOARD, COMPLETE		
R113	1-218-953-11	RES, CHIP	1K 5% 1/16W	*****			
R115	1-218-977-11	RES, CHIP	100K 5% 1/16W	(Ref. No.: 20,000 Series)			
R116	1-218-977-11	RES, CHIP	100K 5% 1/16W	< CAPACITOR >			
R117	1-216-864-11	METAL CHIP	0 5% 1/16W	C4501	1-125-777-11	CERAMIC CHIP	0.1uF 10% 6.3V
R118	1-218-941-11	RES, CHIP	100 5% 1/16W	C4502	1-164-943-11	CERAMIC CHIP	0.01uF 10% 16V
R119	1-218-941-11	RES, CHIP	100 5% 1/16W	C4503	1-104-851-11	TANTALUM CHIP	10uF 20% 10V
R120	1-218-977-11	RES, CHIP	100K 5% 1/16W	C4504	1-104-851-11	TANTALUM CHIP	10uF 20% 10V
R121	1-218-977-11	RES, CHIP	100K 5% 1/16W	C4505	1-164-943-11	CERAMIC CHIP	0.01uF 10% 16V
R122	1-218-977-11	RES, CHIP	100K 5% 1/16W	C4506	1-119-750-11	TANTALUM CHIP	22uF 20% 6.3V
R123	1-218-933-11	RES, CHIP	22 5% 1/16W	C4507	1-117-919-11	TANTALUM CHIP	10uF 20% 6.3V
R124	1-218-953-11	RES, CHIP	1K 5% 1/16W	C4508	1-135-179-21	TANTALUM CHIP	2.2uF 20% 16V
R125	1-218-973-11	RES, CHIP	47K 5% 1/16W	C4509	1-125-777-11	CERAMIC CHIP	0.1uF 10% 10V
R126	1-218-989-11	RES, CHIP	1M 5% 1/16W	C4510	1-107-686-11	TANTALUM CHIP	4.7uF 20% 16V
R127	1-218-973-11	RES, CHIP	47K 5% 1/16W	C4512	1-119-750-11	TANTALUM CHIP	22uF 20% 6.3V
R128	1-218-953-11	RES, CHIP	1K 5% 1/16W	C4514	1-125-777-11	CERAMIC CHIP	0.1uF 10% 10V
R129	1-218-989-11	RES, CHIP	1M 5% 1/16W	C4515	1-125-777-11	CERAMIC CHIP	0.1uF 10% 10V
R130	1-218-989-11	RES, CHIP	1M 5% 1/16W	C4516	1-107-686-11	TANTALUM CHIP	4.7uF 20% 16V
R131	1-218-977-11	RES, CHIP	100K 5% 1/16W	C4517	1-107-686-11	TANTALUM CHIP	4.7uF 20% 16V
R132	1-218-961-11	RES, CHIP	4.7K 5% 1/16W	C4518	1-107-686-11	TANTALUM CHIP	4.7uF 20% 16V
R133	1-218-961-11	RES, CHIP	4.7K 5% 1/16W	C4519	1-115-566-11	CERAMIC CHIP	4.7uF 10% 10V
R134	1-218-957-11	RES, CHIP	2.2K 5% 1/16W	C4520	1-119-750-11	TANTALUM CHIP	22uF 20% 6.3V
R135	1-218-965-11	RES, CHIP	10K 5% 1/16W	C4521	1-135-179-21	TANTALUM CHIP	2.2uF 20% 16V
R136	1-216-864-11	METAL CHIP	0 5% 1/16W	C4522	1-164-943-11	CERAMIC CHIP	0.01uF 10% 16V
R137	1-216-864-11	METAL CHIP	0 5% 1/16W	C4523	1-125-777-11	CERAMIC CHIP	0.1uF 10% 10V
R138	1-216-009-91	RES, CHIP	22 5% 1/10W	C4524	1-164-505-11	CERAMIC CHIP	2.2uF 0% 16V
R201	1-218-961-11	RES, CHIP	4.7K 5% 1/16W	C4525	1-125-777-11	CERAMIC CHIP	0.1uF 10% 10V
R202	1-218-975-11	RES, CHIP	68K 5% 1/16W	C4526	1-107-686-11	TANTALUM CHIP	4.7uF 20% 16V
R203	1-216-864-11	METAL CHIP	0 5% 1/16W	C4527	1-164-943-11	CERAMIC CHIP	0.01uF 10% 16V
R205	1-218-975-11	RES, CHIP	68K 5% 1/16W	C4601	1-115-467-11	CERAMIC CHIP	0.22uF 10% 10V
R206	1-218-989-11	RES, CHIP	1M 5% 1/16W	C4602	1-164-943-11	CERAMIC CHIP	0.01uF 10% 16V
R207	1-218-961-11	RES, CHIP	4.7K 5% 1/16W	C4603	1-104-851-11	TANTALUM CHIP	10uF 20% 10V
R208	1-218-957-11	RES, CHIP	2.2K 5% 1/16W	C4604	1-107-826-91	CERAMIC CHIP	0.1uF 10% 16V
R209	1-218-953-11	RES, CHIP	1K 5% 1/16W	C4605	1-104-916-11	TANTALUM CHIP	6.8uF 20% 20V
R210	1-218-981-11	RES, CHIP	220K 5% 1/16W	C4606	1-164-939-11	CERAMIC CHIP	0.0022uF 10% 16V
R211	1-218-965-11	RES, CHIP	10K 5% 1/16W	C4608	1-107-686-11	TANTALUM CHIP	4.7uF 20% 16V
R212	1-218-985-11	RES, CHIP	470K 5% 1/16W	C4610	1-107-819-11	CERAMIC CHIP	0.022uF 10% 16V
R213	1-218-985-11	RES, CHIP	470K 5% 1/16W	C4611	1-107-819-11	CERAMIC CHIP	0.022uF 10% 16V
R214	1-218-957-11	RES, CHIP	2.2K 5% 1/16W	C4612	1-109-982-11	CERAMIC CHIP	1uF 10% 10V
R215	1-218-969-11	RES, CHIP	22K 5% 1/16W	C4613	1-164-943-11	CERAMIC CHIP	0.01uF 10% 16V
R216	1-218-963-11	RES, CHIP	6.8K 5% 1/16W	C4614	1-164-878-11	CERAMIC CHIP	150PF 5% 16V
R217	1-218-985-11	RES, CHIP	470K 5% 1/16W	C4615	1-164-943-11	CERAMIC CHIP	0.01uF 10% 16V
R218	1-218-953-11	RES, CHIP	1K 5% 1/16W	C4616	1-164-940-11	CERAMIC CHIP	0.0033uF 10% 16V
R219	1-218-953-11	RES, CHIP	1K 5% 1/16W	C4617	1-115-566-11	CERAMIC CHIP	4.7uF 10% 10V
R220	1-218-947-11	RES, CHIP	330 5% 1/16W				
R221	1-218-969-11	RES, CHIP	22K 5% 1/16W				
R222	1-218-953-11	RES, CHIP	1K 5% 1/16W				
R223	1-218-965-11	RES, CHIP	10K 5% 1/16W				

Ref. No.	Part No.	Description	Remark	Ref. No.	Part No.	Description	Remark
C4618	1-164-943-11	CERAMIC CHIP	0.01uF 10% 16V	R4525	1-218-975-11	RES, CHIP	68K 5% 1/16W
C4619	1-135-259-11	TANTALUM CHIP	10uF 20% 6.3V	R4526	1-218-971-11	RES, CHIP	33K 5% 1/16W
C4620	1-164-874-11	CERAMIC CHIP	100PF 5% 16V	R4527	1-218-985-11	RES, CHIP	470K 5% 1/16W
C4621	1-162-964-11	CERAMIC CHIP	0.001uF 10% 50V	R4528	1-218-971-11	RES, CHIP	33K 5% 1/16W
C4622	1-164-943-11	CERAMIC CHIP	0.01uF 10% 16V	R4529	1-218-957-11	RES, CHIP	2.2K 5% 1/16W
C4624	1-107-820-11	CERAMIC CHIP	0.1uF 0% 16V	R4530	1-218-971-11	RES, CHIP	33K 5% 1/16W
C4625	1-165-112-11	CERAMIC CHIP	0.33uF 0% 16V	R4531	1-218-975-11	RES, CHIP	68K 5% 1/16W
< CONNECTOR >				R4532	1-218-971-11	RES, CHIP	33K 5% 1/16W
CN4501	1-784-420-11	CONNECTOR, FFC/FPC (ZIF) 21P		R4533	1-218-849-11	METAL CHIP	3.3K 0.5% 1/16W
CN4601	1-778-596-21	CONNECTOR, BOARD TO BOARD 30P		R4534	1-208-675-11	METAL CHIP	470 0.5% 1/16W
CN4901	1-764-704-21	CONNECTOR, FFC/FPC (LIF) 5P		R4535	1-208-683-11	METAL CHIP	1K 0.5% 1/16W
< DIODE >				R4538	1-218-971-11	RES, CHIP	33K 5% 1/16W
D4601	8-719-043-70	DIODE MA6S121- (TX)		R4539	1-218-975-11	RES, CHIP	68K 5% 1/16W
D4602	8-713-102-80	DIODE 1T369-01-T8A		R4540	1-218-990-11	SHORT	0
< IC >				R4541	1-218-941-11	RES, CHIP	100 5% 1/16W
IC4501	8-759-546-65	IC CXA8115AR-T4		R4542	1-218-941-11	RES, CHIP	100 5% 1/16W
IC4502	8-759-596-12	IC AK9813AFS-E2		R4543	1-218-941-11	RES, CHIP	100 5% 1/16W
IC4601	8-759-097-75	IC MB3789PFV-G-BND		R4544	1-218-957-11	RES, CHIP	2.2K 5% 1/16W
IC4602	8-752-392-33	IC CXD2458AR		R4546	1-218-903-11	METAL CHIP	220K 0.5% 1/16W
< COIL >				R4547	1-218-887-11	METAL CHIP	47K 0.5% 1/16W
L4501	1-414-754-11	INDUCTOR	10uH	R4550	1-218-990-11	SHORT	0
L4502	1-414-754-11	INDUCTOR	10uH	R4551	1-218-990-11	SHORT	0
L4503	1-414-754-11	INDUCTOR	10uH	R4553	1-208-691-11	METAL CHIP	2.2K 0.5% 1/16W
L4601	1-414-406-41	INDUCTOR	220uH	R4556	1-218-969-11	RES, CHIP	22K 5% 1/16W
L4602	1-414-756-11	INDUCTOR	47uH	R4557	1-208-675-11	METAL CHIP	470 0.5% 1/16W
L4603	1-412-949-21	INDUCTOR	6.8uH	R4558	1-208-683-11	METAL CHIP	1K 0.5% 1/16W
< TRANSISTOR >				R4559	1-218-971-11	RES, CHIP	33K 5% 1/16W
Q4502	8-729-037-53	TRANSISTOR	2SB1462J-QR (TX).SO	R4560	1-218-975-11	RES, CHIP	68K 5% 1/16W
Q4503	8-729-037-53	TRANSISTOR	2SB1462J-QR (TX).SO	R4561	1-218-957-11	RES, CHIP	2.2K 5% 1/16W
Q4504	8-729-037-53	TRANSISTOR	2SB1462J-QR (TX).SO	R4562	1-218-875-11	METAL CHIP	15K 0.5% 1/16W
Q4505	8-729-037-53	TRANSISTOR	2SB1462J-QR (TX).SO	R4564	1-218-990-11	SHORT	0
Q4506	8-729-037-53	TRANSISTOR	2SB1462J-QR (TX).SO	R4565	1-218-990-11	SHORT	0
Q4507	8-729-037-53	TRANSISTOR	2SB1462J-QR (TX).SO	R4566	1-218-990-11	SHORT	0
Q4601	8-729-013-73	TRANSISTOR	RN2105-TE85R	R4567	1-218-990-11	SHORT	0
Q4602	8-729-037-61	TRANSISTOR	UN9113J- (TX).SO	R4568	1-218-990-11	SHORT	0
Q4603	8-729-037-74	TRANSISTOR	UN9213J- (TX).SO	R4570	1-208-707-11	METAL CHIP	10K 0.5% 1/16W
< RESISTOR >				R4601	1-217-671-11	METAL CHIP	1 5% 1/10W
R4501	1-216-009-91	RES, CHIP	22 5% 1/10W	R4602	1-217-671-11	METAL CHIP	1 5% 1/10W
R4502	1-218-969-11	RES, CHIP	22K 5% 1/16W	R4603	1-208-719-11	METAL CHIP	33K 0.5% 1/16W
R4503	1-218-990-11	SHORT	0	R4604	1-218-971-11	RES, CHIP	33K 5% 1/16W
R4507	1-218-969-11	RES, CHIP	22K 5% 1/16W	R4605	1-208-939-11	METAL CHIP	150K 0.5% 1/16W
R4508	1-218-975-11	RES, CHIP	68K 5% 1/16W	R4607	1-208-927-11	METAL CHIP	47K 0.5% 1/16W
R4514	1-208-711-11	METAL CHIP	15K 0.5% 1/16W	R4608	1-218-975-11	RES, CHIP	68K 5% 1/16W
R4515	1-208-691-11	METAL CHIP	2.2K 0.5% 1/16W	R4609	1-218-981-11	RES, CHIP	220K 5% 1/16W
R4516	1-218-990-11	SHORT	0	R4610	1-218-973-11	RES, CHIP	47K 5% 1/16W
R4517	1-218-990-11	SHORT	0	R4611	1-218-965-11	RES, CHIP	10K 5% 1/16W
R4518	1-218-990-11	SHORT	0	R4612	1-218-973-11	RES, CHIP	47K 5% 1/16W
R4519	1-208-675-11	METAL CHIP	470 0.5% 1/16W	R4613	1-218-973-11	RES, CHIP	47K 5% 1/16W
R4520	1-208-683-11	METAL CHIP	1K 0.5% 1/16W	R4614	1-218-965-11	RES, CHIP	10K 5% 1/16W
R4523	1-218-971-11	RES, CHIP	33K 5% 1/16W	R4615	1-218-969-11	RES, CHIP	22K 5% 1/16W
R4524	1-218-975-11	RES, CHIP	68K 5% 1/16W	R4616	1-218-969-11	RES, CHIP	22K 5% 1/16W
R4525	1-218-975-11	RES, CHIP	68K 5% 1/16W	R4617	1-218-985-11	RES, CHIP	470K 5% 1/16W
R4526	1-218-971-11	RES, CHIP	33K 5% 1/16W	R4618	1-218-953-11	RES, CHIP	1K 5% 1/16W
R4527	1-218-985-11	RES, CHIP	470K 5% 1/16W	R4619	1-218-971-11	RES, CHIP	33K 5% 1/16W
R4528	1-218-971-11	RES, CHIP	33K 5% 1/16W	R4620	1-218-979-11	RES, CHIP	150K 5% 1/16W
R4529	1-218-957-11	RES, CHIP	2.2K 5% 1/16W	R4621	1-218-979-11	RES, CHIP	150K 5% 1/16W
R4530	1-218-971-11	RES, CHIP	33K 5% 1/16W	R4622	1-218-961-11	RES, CHIP	4.7K 5% 1/16W

Ref. No.	Part No.	Description	Remark
R4623	1-218-983-11	RES, CHIP	330K 5% 1/16W
R4624	1-218-971-11	RES, CHIP	33K 5% 1/16W
R4626	1-218-969-11	RES, CHIP	22K 5% 1/16W
R4627	1-218-965-11	RES, CHIP	10K 5% 1/16W
R4628	1-218-971-11	RES, CHIP	33K 5% 1/16W
R4629	1-218-990-11	SHORT	0
R4630	1-218-953-11	RES, CHIP	1K 5% 1/16W
R4634	1-218-990-11	SHORT	0
R4636	1-218-963-11	RES, CHIP	6.8K 5% 1/16W
*****			
MISCELLANEOUS			
*****			
14	1-418-201-21	SWITCH UNIT, MAIN CONTROL	
56	1-672-513-11	TRANSLATION FLEXIBLE (JACK) BOARD	
61	1-418-563-11	TERMINAL UNIT, REMOTE	
69	1-418-202-21	SWITCH UNIT, ZOOM	
78	1-694-497-11	TERMINAL BOARD, BATTERY	
110	1-418-564-11	RAY-CATCHER BLOCK UNIT, REMOCON	
112	1-418-192-11	MICROPHONE UNIT	
122	1-672-514-11	TRANSLATION FLEXIBLE BOARD	
169	X-3378-951-1	CONTROL SW SUB ASSY, UPPER	
207	1-959-252-11	HARNESS (GLAY)	
208	1-959-251-11	HARNESS (YELLOW)	
△ 213	1-517-843-11	FLUORESCENT TUBE	
215	1-672-355-11	LCD DETECTION SW FLEXIBLE BOARD	
221	1-803-445-11	PANEL, TOUCH	
251	1-672-356-11	VF/LCD FLEXIBLE BOARD	
267	1-672-357-11	VF FLEXIBLE BOARD	
304	8-848-732-01	DEVICE, LENS (LSV-620B)	
306	1-758-202-21	FILTER BLOCK, OPTICAL	
408	1-675-950-11	MOTOR FLEXIBLE BOARD	
409	1-418-191-11	SENSOR, MR	
417	1-452-997-11	ENCODER, MAGNET	
M5811	1-698-543-21	MOTOR (STEPPING)	
LCD4301	1-803-033-21	INDICATOR MODULE, LIQUID CRYSTAL	
LCD4701	8-753-023-89	LCX024AK-5	
*****			
*****			
HARDWARE LIST			
*****			
#1	7-621-591-00	SCREW +K 2X4	
#2	7-623-505-01	LUG, 2	
#3	7-628-253-15	SCREW +PS 2X5	
*****			

Ref. No.	Part No.	Description	Remark
ACCESSORIES & PACKING MATERIALS			
*****			
△	1-418-327-21	CHARGER, AC ADAPTOR (AC-VQ800)	
	1-418-732-21	REMOTE COMMANDER (RMT-DCM1)	
	1-543-793-11	FILTER, CLAMP (FERRITE CORE) (SMALL)	
	1-543-798-11	FILTER, CLAMP (FERRITE CORE) (LARGE)	
	1-765-080-11	CORD, CONNECTION (STEREO AV) (1.5m)	
△	1-790-107-22	CORD, POWER	
	1-790-351-11	CORD, CONNECTION (ZK-ET1) (1.8m)	
	3-742-854-01	LID, BATTERY (for RMT-DCM1)	
	3-866-152-11	MANUAL, INSTRUCTION (ENGLISH)	
	3-866-152-21	MANUAL, INSTRUCTION (FRENCH) (Canadian)	
	3-987-015-01	BELT (S), SHOULDER	
	4-220-941-01	ATTACHMENT (TRIPOD)	

<p>The components identified by mark △ or dotted line with mark △ are critical for safety. Replace only with part number specified.</p>	<p>Les composants identifiés par une marque △ sont critiques pour la sécurité. Ne les remplacer que par une pièce portant le numéro spécifié.</p>
---	---



**< PARTS REFERENCE SHEET >**

You can find the parts position of mount locations applying to MAIN board of a set.

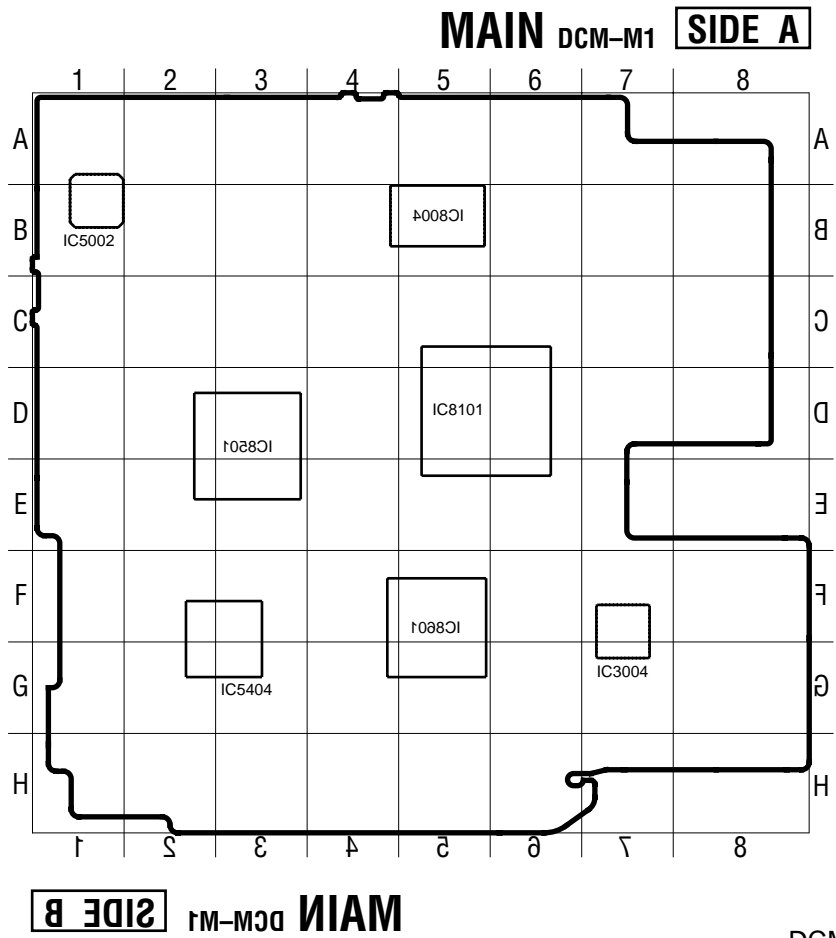



# DCM-M1

SONY®

## SERVICE MANUAL

2000. 03

US Model  
Canadian Model  
E Model

### SUPPLEMENT-1



File this supplement with the service manual.

**Subject:**

1. Change of General
2. Correction of Schematic Diagram
3. Change of repair parts
4. Addition of the note about a special tool for ICs.
5. Addition of the instruction manual for Argentina model.

#### 1. Change of General

 : Indicates changed portion.

Page	Before Change	After Change
1-14	<p><b>Note on the figure in "TOTAL"</b> "TOTAL" shows the total playback time of movie, photo, memo and title tracks recorded in the disc. Playback time of each still picture track (photo, memo and title) is the one set in the menu.</p> <p><b>Note on the figure in "REMAIN"</b> • "REMAIN" shows the remaining recording time or tracks. • If you set REC MODE to VP, you may be able to record longer than the indicated recording time. • If more than 10 hours remain in the disc, "<u>MORE THAN 10 HRS</u>" appears.</p> 	<p><b>Note on the figure in "TOTAL"</b> "TOTAL" shows the total playback time of movie, photo, memo and title tracks recorded in the disc. Playback time of each still picture track (photo, memo and title) is the one set in the menu.</p> <p><b>Note on the figure in "REMAIN"</b> • "REMAIN" shows the remaining recording time or tracks. • If you set REC MODE to VP, you may be able to record longer than the indicated recording time. • If more than 10 hours remain in the disc, "<u>10 H Over</u>" appears.</p> 

#### 2. Correction of Schematic Diagram

Page 4-49 to 4-50. Location G to H, 14 to 16.

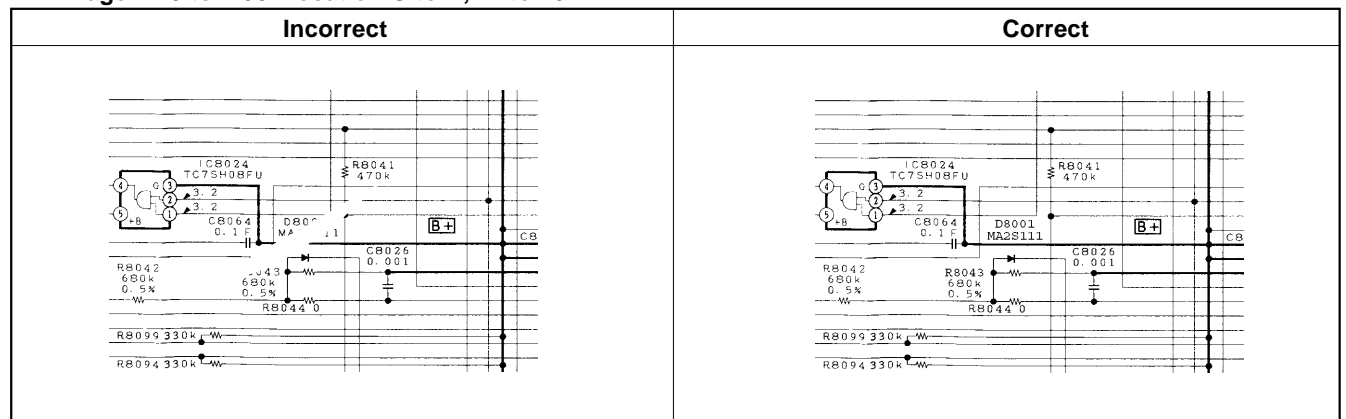

### 3. Change of repair parts (Section 5 Exploded Views/Section 6 Electrical Parts List)

 : Indicates changed portion.

Page	Before Change				After Change			
	Ref. No.	Part No.	Description	Remark	Ref. No.	Part No.	Description	Remark
5-2 Ref No. 52/6-15 5-2 Ref No. 57/6-3 5-6 Ref No. 252/6-1 5-6 Ref No. 266/6-19 5-7		A-3321-881-A	POWER BOARD, COMPLETE			A-3323-172-A	POWER BOARD ASSY	
		A-3321-883-A	JACK BOARD, COMPLETE			A-3323-173-A	JACK BOARD ASSY	
		A-3321-877-A	BL BOARD, COMPLETE			A-3323-170-A	BL BOARD ASSY	
		A-3321-879-A	VF BOARD, COMPLETE			A-3323-171-A	VF BOARD ASSY	
			not supplied (IC001)		312	A-3328-667-A	CCD BLOCK ASSY	



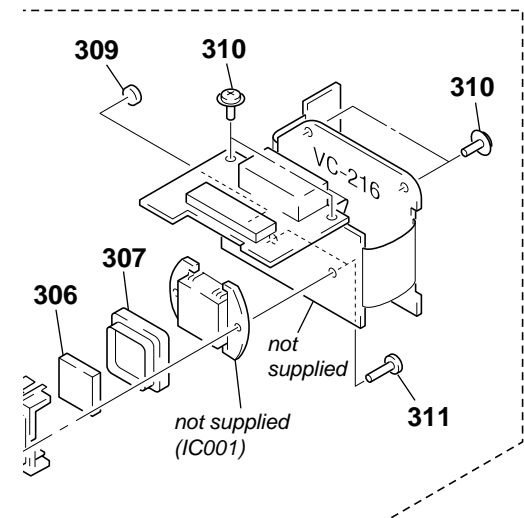

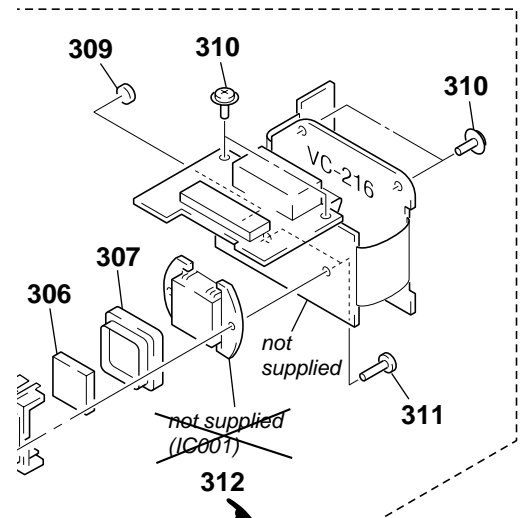
### 4. Additional of the note about a special tool for ICs. (Electrical Parts List MAIN Board)

Note: @ Replacement of the following ICs used in this set requires a special tool.

Therefore, it cannot be replaced.

Page	IC				Page	IC			
	Ref. No.	Part No.	Description	Remark		Ref. No.	Part No.	Description	Remark
6-9	@IC3009	8-752-397-21	IC CXZ31021GA		6-10	@IC8005	1-803-635-11	IC WTGA-EKM29U64000-K1	
	@IC5301	8-752-397-34	IC CXD2652AGA			@IC8101	8-752-396-85	IC CXD702-102GA	
	@IC5403	8-752-390-38	IC CXD606-112GA			@IC8102	8-759-572-71	IC KM416U4104BC-L6	
	@IC5404	8-759-676-88	IC RU6815TC-DCMM1			@IC8103	8-759-572-71	IC KM416U4104BC-L6	
6-10	@IC8001	8-759-572-52	IC HD6417709BT80A		@IC8501	8-759-653-48	IC uPD70F3102F1-33-FA1		
	@IC8002	8-759-572-70	IC KM416S4034CC-C10		@IC8601	8-752-396-81	IC CXD1405GG		
	@IC8003	8-759-572-70	IC KM416S4034CC-C10		@IC8701	8-752-394-48	IC CXD1404GA		

### 5. Additional of the instruction manual for Argentina model.

Page	ACCESSORIES & PACKING MATERIALS			
	Ref. No.	Part No.	Description	Remark
6-21		3-866-152-31	MANUAL, INSTRUCTION (SPANISH) (Argentina)	