

# XR-1300R/C2300R

## SERVICE MANUAL

Ver 1.1 2001.02

AEP Model  
UK Model



Photo: XR-C2300R

Model Name Using Similar Mechanism	NEW
Tape Transport Mechanism Type	MG-36SZ10-32

### SPECIFICATIONS

#### Cassette player section

Tape track	4-track 2-channel stereo
Wow and flutter	0.13 % (WRMS)
Frequency response	30 – 15,000 Hz
Signal-to-noise ratio	55 dB

#### Tuner section

<b>FM</b>	
Tuning range	87.5 – 108.0 MHz
Aerial terminal	External aerial connector
Intermediate frequency	10.7 MHz
Usable sensitivity	9 dBf
Selectivity	75 dB at 400 kHz
Signal-to-noise ratio	65 dB (stereo), 68 dB (mono)
Harmonic distortion at 1 kHz	0.7 % (stereo), 0.4 % (mono)
Separation	35 dB at 1 kHz
Frequency response	30 – 15,000 Hz

#### MW/LW

Tuning range	MW: 531 – 1,602 kHz LW: 153 – 279 kHz
Aerial terminal	External aerial connector
Intermediate frequency	10.7 MHz/450 kHz
Sensitivity	MW: 30 $\mu$ V LW: 50 $\mu$ V

#### Power amplifier section

Outputs	Speaker outputs (sure seal connectors)
Speaker impedance	4 – 8 ohms
Maximum power output	45 W $\times$ 4 (at 4 ohms)

#### General

Outputs	Audio output (XR-C2300R) Power aerial relay control lead Power amplifier control lead
Tone controls	Bass $\pm$ 8 dB at 100 Hz Treble $\pm$ 8 dB at 10 kHz
Power requirements	12 V DC car battery (negative earth)
Dimensions	Approx. 188 $\times$ 58 $\times$ 182 mm (w/h/d)
Mounting dimensions	Approx. 182 $\times$ 53 $\times$ 163 mm (w/h/d)
Mass	Approx. 1.2 kg
Supplied accessories	Parts for installation and connections (1 set) Front panel case (1)

*Design and specifications are subject to change without notice.*

## FM/MW/LW CASSETTE CAR STEREO

9-870-024-12  
2001B0500-1  
© 2001.2

**Sony Corporation**  
Audio Entertainment Group  
General Engineering Dept.

# SONY®

## TABLE OF CONTENTS

<b>1. GENERAL</b>	
Location of Controls (XR-1300R) .....	3
Setting the Clock .....	3
Locations of Controls (XR-C2300R) .....	4
Setting the Clock .....	4
Installation .....	5
Connections .....	6
<b>2. DISASSEMBLY</b> .....	9
<b>3. MECHANICAL ADJUSTMENTS</b> .....	12
<b>4. ELECTRICAL ADJUSTMENTS</b>	
Tape Deck Section .....	13
Tuner Section .....	14
<b>5. DIAGRAMS</b>	
5-1. Note for Printed Wiring Boards and Schematic Diagrams .....	17
5-2. Printed Wiring Board – MAIN Board (Component Side) – .....	18
5-3. Printed Wiring Board – MAIN Board (Conductor Side) – .....	19
5-4. Schematic Diagram – MAIN Board (1/2) – .....	20
5-5. Schematic Diagram – MAIN Board (2/2) – .....	21
5-6. Printed Wiring Board – CONTROL Board – .....	22
5-7. Schematic Diagram – CONTROL Board – .....	23
5-8. IC Pin Function Description .....	25
<b>6. EXPLODED VIEWS</b> .....	28
<b>7. ELECTRICAL PARTS LIST</b> .....	31

### Flexible Circuit Board Repairing

- Keep the temperature of the soldering iron around 270 °C during repairing.
- Do not touch the soldering iron on the same conductor of the circuit board (within 3 times).
- Be careful not to apply force on the conductor when soldering or unsoldering.

### Notes on chip component replacement

- Never reuse a disconnected chip component.
- Notice that the minus side of a tantalum capacitor may be damaged by heat.

# SECTION 1 GENERAL

This section is extracted from instruction manual.

(XR-1300R)

## Location of controls

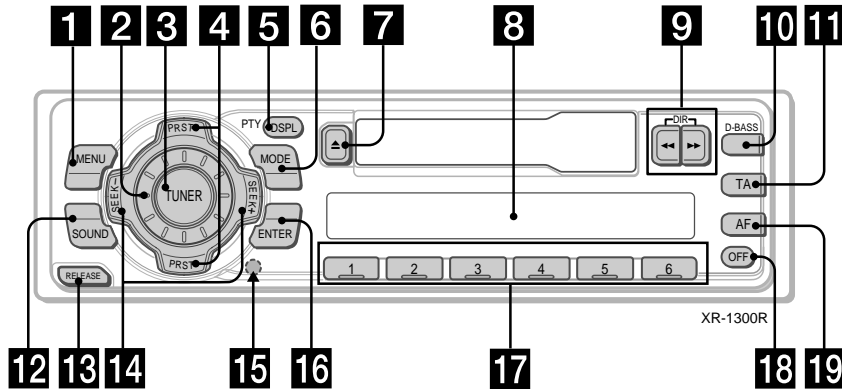

Refer to the pages listed for details.

- 1** MENU button  
7, 8, 9, 11, 13, 14, 15
- 2** Volume control dial
- 3** TUNER button 8, 9, 12
- 4** PRST +/- (cursor up/down) buttons  
7, 8, 9, 11, 13, 14, 15  
During radio reception:  
Preset stations select 8, 9
- 5** DSPL/PTY (display mode change/  
programme type) button 14
- 6** MODE button  
During radio reception:  
BAND select 8, 9
- 7** ▲ (eject) button 7
- 8** Display window
- 9** ◀▶ (fast winding)/DIR (tape  
transport direction change) buttons 7
- 10** D-BASS button 16
- 11** TA button 12, 13
- 12** SOUND button 15
- 13** RELEASE (front panel release) button  
6, 17
- 14** SEEK +/- (cursor left/right) buttons  
7, 8, 9, 11, 13, 14, 15  
seek 9
- 15** Reset button (located on the front side  
of the unit behind the front panel) 6
- 16** ENTER button 7, 8, 9, 11, 13, 14, 15
- 17** Preset number buttons 9, 11
- 18** OFF button\* 6
- 19** AF button 10, 11, 13

\* **Warning when installing in a car without ACC (accessory) position on the ignition key switch**  
Be sure to press (OFF) on the unit for two seconds to turn off the clock display after turning off the engine.  
When you press (OFF) momentarily, the clock display does not turn off and this causes battery wear.

## Setting the clock

The clock uses a 24-hour digital indication.

Example: To set the clock to 10:08

- 1** Press (MENU), then press either side of (PRST) repeatedly until "CLOCK" appears.



- 1** Press (ENTER).



The hour indication flashes.

- 2** Press either side of (PRST) to set the hour.



- 3** Press + side of (SEEK).



The minute indication flashes.

- 4** Press either side of (PRST) to set the minute.



- 2** Press (ENTER).



The clock starts.

After the clock setting is complete, the display returns to normal playback mode.

## Location of controls

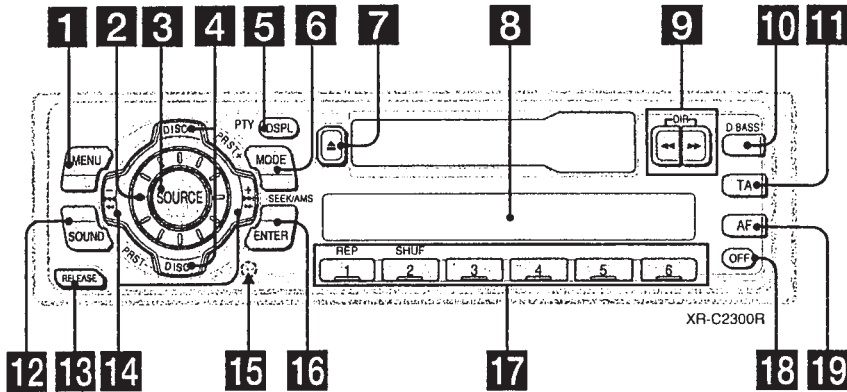

Refer to the pages listed for details.

- 1** MENU button  
7, 8, 9, 10, 12, 14, 15, 16, 18
- 2** Volume control dial
- 3** SOURCE (TUNER/CD/MD) button  
9, 13, 17
- 4** PRST/DISC +/- (cursor up/down) buttons  
7, 8, 9, 10, 12, 14, 15, 16, 18, 19  
During radio reception:  
Preset stations select 8, 9, 10  
During CD/MD playback:  
Disc change 19
- 5** DSPL/PTY (display mode change/  
programme type) button  
8, 10, 11, 15, 18
- 6** MODE button  
During radio reception:  
BAND select 9  
During CD or MD playback:  
CD/MD unit select 17
- 7** ▲ (eject) button 7
- 8** Display window
- 9** ◀▶ (fast winding)/DIR (tape  
transport direction change) buttons 7
- 10** D-BASS button 17
- 11** TA button 13, 14
- 12** SOUND button 16

- 13** RELEASE (front panel release) button  
6, 20
- 14** SEEK/AMS +/- (cursor left/right) buttons  
7, 8, 9, 10, 12, 14, 15, 16, 18, 19  
seek 9, 10  
Automatic Music Sensor 19  
manual search 19
- 15** Reset button (located on the front side  
of the unit behind the front panel) 6
- 16** ENTER button  
7, 8, 9, 10, 12, 14, 15, 16, 18
- 17** Number buttons  
During radio reception  
Preset number select 9, 12  
During CD/MD playback:  
① REP 19  
② SHUF 19
- 18** OFF button\* 6
- 19** AF button 11, 12, 14

**\* Warning when installing in a car without ACC (accessory) position on the ignition key switch**  
Be sure to press (OFF) on the unit for two seconds to turn off the clock display after turning off the engine.  
When you press (OFF) momentarily, the clock display does not turn off and this causes battery wear.

## Setting the clock

The clock uses a 24-hour digital indication.

Example: To set the clock to 10:08

- 1** Press (MENU), then press either side of (PRST/DISC) repeatedly until "CLOCK" appears.



- 1** Press (ENTER).



The hour indication flashes.

- 2** Press either side of (PRST/DISC) to set the hour.



- 3** Press + side of (SEEK/AMS).



The minute indication flashes.

- 4** Press either side of (PRST/DISC) to set the minute.

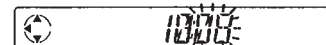

- 2** Press (ENTER).



The clock starts.

After the clock setting is complete, the display returns to normal playback mode.

# Installation

## Precautions

- Choose the installation location carefully so that the unit will not interfere with normal driving operations.
- Avoid installing the unit in areas subject to dust, dirt, excessive vibration, or high temperatures, such as in direct sunlight or near heater ducts.
- Use only the supplied mounting hardware for a safe and secure installation.

## Mounting angle adjustment

Adjust the mounting angle to less than 20°.

## How to detach and attach the front panel

Before installing the unit, detach the front panel.

### A To detach

Before detaching the front panel, be sure to press (OFF). Press (RELEASE), then slide the front panel a little to the left, and pull it off towards you.

### B To attach

Attach part (A) of the front panel to part (B) of the unit as illustrated and push the left side into position until it clicks.

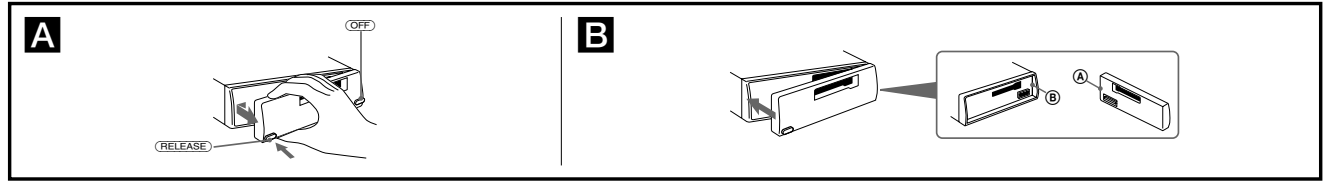

## Installation in the dashboard

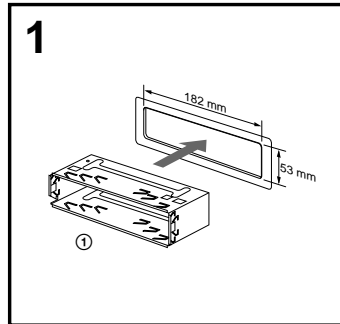

## Instalación en el salpicadero

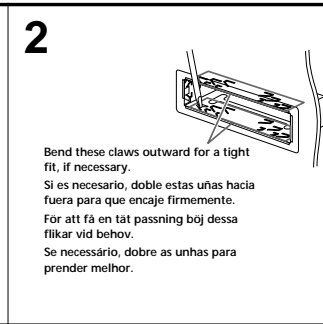

## Montering i instrumentinfattning

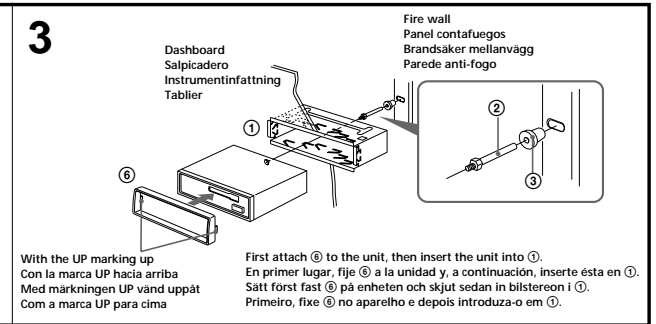

## Caution

Remove the protection collar (6) before installing.

## Precaución

Extraiga el collar de protección (6) antes de realizar la instalación.

## Varning

Avlägsna skyddsringen (6) innan du installerar enheten.

## Cuidado

Antes de fazer a instalação retire a moldura protectora (6).

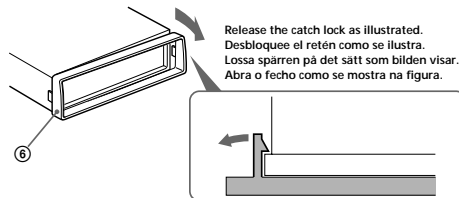

# Instalación

## Precauciones

- Elija cuidadosamente el lugar de montaje de forma que la unidad no interfiera las funciones normales de conducción.
- Evite instalar la unidad donde pueda quedar sometida a altas temperaturas, como a la luz solar directa o al aire de calefacción, o a polvo, suciedad o vibraciones excesivas.
- Para realizar una instalación segura y firme, emplee solamente la ferretería de montaje suministrada.

## Ajuste del ángulo de montaje

Ajuste el ángulo de montaje a menos de 20°.

## Forma de extraer e instalar el panel frontal

Antes de instalar la unidad, extraiga el panel frontal.

### A Para extraerlo

Antes de extraer el panel frontal, asegúrese de pulsar (OFF). Pulse (RELEASE), deslice el panel ligeramente hacia la izquierda y tire de él hacia fuera.

### B Para instalarlo

Fije la parte (A) del panel frontal a la parte (B) de la unidad tal como muestra la ilustración y ejerza presión sobre el lado izquierdo hasta oír un chasquido.

# Montering

## Att observera

- Var noga när du väljer var i bilen du monterar bilstereon, så att den inte sitter i vägen när du kör.
- Montera inte bilstereon där den utsätts för värme, t ex solsken eller varmluft, eller där den utsätts för damm, smuts och/eller vibrationer.
- Använd endast de medföljande monteringsstillbehören för att vara säkra på att bilstereon monteras på säkert och korrekt sätt.

## Tillåten monteringsvinkel

Monteringsvinkeln måste vara under 20 grader.

## Hur framsidan tas loss/fästs

Ta loss framsidan före bilstereons montering.

### A Hur framsidan tas loss

Se till att enheten är avstängd innan du tar bort Frontpanelen. Tryck på (OFF). Tryck sedan på (RELEASE) och skjut frontpanelen lite åt vänster medan du drar den emot dig.

### B Hur framsidan fästs i bilstereon

Sätt fast del (A) på frontpanelen på del (B) på enheten enligt bilden och tryck på den vänstra sidan tills det klickar till.

# Instalação

## Precauções

- Escolha com cuidado um local apropriado para a montagem do aparelho, para que este não interfira com as manobras necessárias à condução do veículo.
- Evite instalar o aparelho onde possa estar sujeito a altas temperaturas, como em locais expostos directamente à luz do sol, ao ar quente dos aquecimentos, ou sujeitos a pó, sujidade ou vibração excessiva.
- Utilize somente o jogo de montagem fornecido para efectuar uma instalação segura.

## Ajuste do ângulo de montagem

Ajuste o ângulo de montagem a menos de 20°.

## Para retirar e colocar o painel frontal

Antes de iniciar a instalação do aparelho, remova o painel frontal.

### A Para remover

Antes de retirar o painel frontal, tem de carregar em (OFF). Carregue em (RELEASE), faça deslizar o painel um pouco para a esquerda e puxe-o para si.

### B Para colocar

Encaixe a parte (A) do painel frontal na parte (B) do aparelho, como se mostra na figura, fazendo pressão sobre o painel até ouvir um estalido.

# Connections

## Cautions

- This unit is designed for negative earth 12 V DC operation only.
- Be careful not to pinch any wires between a screw and the body of the car or this unit or between any moving parts such as the seat railing, etc.
- Connect the power connecting cord (Ⓢ) to the unit and speakers before connecting it to the auxiliary power connector.
- Run all earth wires to a common earth point.
- Connect the yellow cord to a free car circuit rated higher than the unit's fuse rating. If you connect this unit in series with other stereo components, the car circuit they are connected to must be rated higher than the sum of the individual components' fuse rating. If there are no car circuits rated as high as the unit's fuse rating, connect the unit directly to the battery. If no car circuits are available for connecting this unit, connect the unit to a car circuit rated higher than the unit's fuse rating in such a way that if the unit blows its fuse, no other circuits will be cut off.

## Warning when installing in a car without ACC (accessory) position on the ignition key switch

Be sure to press (OFF) on the unit for two seconds to turn off the clock display after turned off the engine.

When you press (OFF) momentarily, the clock display does not turn off and this causes battery wear.

## Notes of connection example

### Notes on the control leads

- The power aerial control lead (blue) supplies +12 V DC when you turn on the unit.
- When your car has a built-in FM/MW/LW aerial in the rear/side glass, it is necessary to connect the power aerial control lead (blue) or the accessory power input lead (red) to the power terminal of the existing aerial booster. For details, consult your dealer.
- A power aerial without a relay box cannot be used with this unit.

### Warning

If you have a power aerial without a relay box, connecting this unit with the supplied power connecting cord (Ⓢ) may damage the aerial.

### Memory hold connection

When the yellow power input lead is connected, power will always be supplied to the memory circuit even when the ignition switch is turned off.

### Notes on speaker connection

- Before connecting the speakers, turn the unit off.
- Use speakers with an impedance of 4 to 8 ohms, and with adequate power handling capacities.
- Otherwise, the speakers may be damaged.
- Do not connect the terminals of the speaker system to the car chassis, and do not connect the terminals of the right speaker with those of the left speaker.
- Do not attempt to connect the speakers in parallel.
- Do not connect any active speakers (with built-in amplifiers) to the speaker terminals of the unit. Doing so may damage the active speakers. Be sure to connect passive speakers to these terminals.

### \*1 Note for the aerial connecting

If your car aerial is an ISO (International Organization for Standardization) type, use the supplied adapter (Ⓢ) to connect it. First connect the car aerial to the supplied adapter, then connect it to the aerial jack of the master unit.

### \*2 To AMP REMOTE IN of the optional power amplifier

This connection is only for amplifiers. Connecting any other system may damage the unit.

# Conexiones

## Precauciones

- Esta unidad ha sido diseñada para alimentarse con 12 V CC, negativo a masa, solamente.
- Tenga cuidado de no atrapar ningún cable entre algún tornillo y la carrocería del automóvil o esta unidad, o entre las partes móviles, como por ejemplo los raíles del asiento, etc.
- Conecte el cable de conexión de alimentación (Ⓢ) a la unidad y los altavoces antes de conectarlo al conector de alimentación auxiliar.
- Conecte todos los conductores de puesta a masa a un punto común.
- Conecte el cable amarillo a un circuito libre del automóvil de potencia nominal superior a la del fusible de la unidad. Si conecta esta unidad en serie con otros componentes estéreo, la potencia nominal del circuito del automóvil a los que dichos componentes estén conectados debe ser superior a la suma de la potencia nominal del fusible de los componentes. Si no existen circuitos del automóvil de potencia nominal igual a la del fusible de la unidad, conecte ésta directamente a la batería. Si no hay circuitos del automóvil disponibles para conectar esta unidad, conecte la misma a un circuito del automóvil de potencia nominal superior a la del fusible de la unidad de forma que no se desactiven otros circuitos si el fusible de dicha unidad se funde.

## Advertencia sobre la instalación en un automóvil que no disponga de posición ACC (accesorios) en el interruptor de la llave de encendido

Asegúrese de pulsar (OFF) en la unidad durante dos segundos para desactivar la indicación del reloj una vez apagado el motor. Si pulsa (OFF) momentáneamente, la indicación del reloj no se desactivará y esto causará el desgaste de la batería.

## Notas de ejemplo de conexiones

### Notas sobre conductores de control

- El conductor de control de la antena motorizada (azul) suministra +12 V CC al encender la unidad.
- Si el automóvil dispone de antena de FM/MW/LW incorporada en el cristal trasero/lateral, será necesario conectar el cable de control de antena motorizada (azul) o el cable de entrada de alimentación accesoria (rojo) al terminal de potencia del amplificador de antena existente. Para más información, consulte con el proveedor.
- Con esta unidad no podrá utilizarse una antena motorizada sin caja de relés.

### Advertencia

Si dispone de una antena motorizada sin dispositivo de relé, la conexión de esta unidad con el cable de conexión de alimentación (Ⓢ) suministrado puede dañar la antena.

### Conexión para protección de la memoria

Si conecta el conductor de entrada de alimentación amarillo, el circuito de la memoria recibirá siempre alimentación, incluso aunque ponga la llave de encendido en la posición de apagado.

### Notas sobre la conexión de los altavoces

- Antes de conectar los altavoces, desconecte la alimentación de la unidad.
- Utilice altavoces con una impedancia de 4 a 8 ohmios, y con la potencia máxima admisible adecuada, ya que de lo contrario podría dañarlos.
- No conecte los terminales del sistema de altavoces al chasis del automóvil, ni los del altavoz izquierdo a los del derecho.
- No intente conectar los altavoces en paralelo.
- No conecte altavoces activos (con amplificadores incorporados) a los terminales de altavoces de la unidad. Si lo hiciera, podría dañar tales altavoces. Por lo tanto, cerciórese de conectar altavoces pasivos a estos terminales.

### \*1 Nota sobre la conexión de la antena

Si la antena del automóvil es del tipo ISO (International Organization for Standardization), emplee el adaptador suministrado (Ⓢ) para conectarla.

En primer lugar, conecte la antena del automóvil al adaptador suministrado y, a continuación, a la toma de antena de la unidad principal.

### \*2 Para conectar a AMP REMOTE IN del amplificador de potencia opcional

Esta conexión es sólo para amplificadores. La conexión de cualquier otro sistema puede dañar la unidad.

# Anslutning

## Att observera

- Denna bilstereo är endast avsedd för anslutning till ett negativt jordat, 12 V bilbatteri.
- Var noga med att inga kablar kläms mellan någon skruv eller att de blir klämda mellan rörliga delar som t.ex. bilsätet.
- Anslut strömkabeln (Ⓢ) till enheten och högtalarna innan du ansluter den till den yttre strömanslutningen.
- Dra samtliga jordledningar till en och samma jordningspunkt.
- Anslut den gula kabeln till en ledig bilbikrets med en högre ampere än enhetens. Om du seriekopplar enheten till andra stereokomponenter måste den bilbikrets de kopplas till ha en högre ampere än summan av de enskilda delarnas amperestyrka. Om det inte finns några bilbikretsar med en så hög amperestyrka som enhetens ska du ansluta enheten direkt till batteriet. Om inga bilbikretsar finns för anslutning till enheten ska du ansluta enheten till en bilbikrets med en högre ampere än enhetens styrka så att inga andra säkringar går om enhetens säkring smälter.

## Var försiktig när du gör installationen i en bil där tändningslåset saknar tillbehörsäge (ACC)

Glöm inte att trycka på (OFF) på enheten under två sekunder för att stänga av klockans teckenfönster efter det att du har stängt av motorn.

Om du bara trycker på (OFF) ett kort ögonblick slocknar inte klockans teckenfönster vilket kan leda till att batteriet laddas ur.

## Att observera angående anslutningsexemplet

### Att observera angående de olika styrkablarna

- Kontrollledningen för antennen (blå) leder +12 V när du slår på enheten.
- Om bilen har en FM/MW/LW-antenn som är inbyggd i sido- eller bakrutan, måste du ansluta motorantennens styrkabel (blå) eller tillbehörströmkabeln (röd) till strömterminalen på antennförstärkaren. Din återförsäljare kan ge dig mer information.
- En motorantenn utan styrrelåda kan inte anslutas till denna bilstereo.

### Varning

Om du har en motorantenn utan relåda kan antennen skadas om du ansluter enheten med den medföljande strömkabeln (Ⓢ).

### Anslutning för minneslåd

När du ansluter den gula, ingående strömkabeln försörjs minneslådan med ström hela tiden, även när tändlåset slås ifrån.

### Att observera angående högtalarnas anslutning

- Slå av bilstereon innan du ansluter högtalarna.
- Anslut endast högtalare, vars impedans varierar från 4 till 8 ohm och som har tillräcklig effektkapacitet för att skydda högtalarna mot skador.
- Anslut inte något av högtalaruttagen till bilens chassi. Anslut inte heller uttagen på höger högtalare till uttagen på vänster högtalare.
- Anslut inte högtalarna parallellt.
- Anslut inte aktiva högtalare (med inbyggda slutsteg) till aktiva högtalarna. Var noga med att bara ansluta passiva högtalare till dessa uttag.

### \*1 Angående antennanslutning

Om bilantennen är av ISO-typ (International Organization for Standardization), använd den medföljande adapter (Ⓢ) för att ansluta den. Anslut först bilantennen till medföljande adapter och därefter till antennuttaget på huvudenheten.

### \*2 Anslut till AMP REMOTE IN på den valfria effektförstärkaren

Denna anslutning gäller endast för högtalare. Om du ansluter något annat system kan enheten skadas.

# Ligações

## Advertência

- Este aparelho foi projectado para funcionar somente com 12 V CC, terra negativa.
- Tenha cuidado para que os fios não fiquem entalados entre os parafusos e a carroçaria do automóvel ou a caixa do aparelho nem entre as peças móveis, por exemplo, as calhas dos bancos, etc.
- Ligue o cabo de alimentação de corrente (Ⓢ) ao aparelho e aos alifalantes antes de o ligar ao conector de corrente auxiliar.
- Ligue todos os fios terra num ponto comum na carroçaria.
- Ligue o cabo amarelo a um circuito eléctrico livre do automóvel, cuja tensão seja superior à dos fusíveis do aparelho. Se ligar este aparelho em série com outros componentes estéreo, a tensão do circuito eléctrico do automóvel onde os ligar tem de ser superior à soma das tensões dos fusíveis de todos os componentes individuais. Se não houver nenhum circuito eléctrico do automóvel com uma tensão tão elevada como a dos fusíveis do aparelho, ligue-o directamente à bateria. Se não estiver disponível nenhum circuito eléctrico do automóvel para ligar aparelho, ligue-o a um circuito eléctrico do automóvel com uma tensão superior à dos fusíveis do aparelho, de tal modo que, se o aparelho rebentar os fusíveis respectivos, nenhum outro circuito seja cortado.

## Aviso sobre a instalação num automóvel sem posição ACC (acessórios) na chave de ignição

Verifique se carregou em (OFF) no aparelho durante dois segundos para desactivar o visor do relógio depois de ter desligado o motor. Se carregar durante alguns momentos em (OFF), não desactiva o visor do relógio o que provoca o desgaste da bateria.

## Notas sobre o exemplo de ligação

### Notas sobre os fios de controlo

- O fio de controlo da antena eléctrica (azul) fornece +12 V CC quando liga o aparelho.
- Se o seu automóvel tiver uma antena de FM/MW/LW montada no vidro traseiro/lateral, tem de ligar o fio de controlo da antena eléctrica (azul) ou o fio de entrada de alimentação para os acessórios (vermelho) ao terminal de alimentação do intensificador do sinal da antena existente.
- Não pode utilizar uma antena eléctrica sem caixa de relé com este aparelho.

### Advertência

Se a antena eléctrica não tiver uma caixa de relé, o facto de ligar este aparelho com o cabo de alimentação (Ⓢ) fornecido, pode provocar danos na antena.

### Ligação para alimentação contínua da memória

Quando o fio amarelo de entrada de alimentação for ligado, os circuitos de memória ficarão com alimentação contínua, mesmo se a chave de ignição estiver desligada.

### Notas sobre a ligação dos alifalantes

- Antes de ligar os alifalantes, desligue o aparelho.
- Utilize alifalantes com impedância de 4 a 8 ohm, e com capacidade admissível de potência adequada. Caso contrário, os alifalantes poderão sofrer avarias.
- Não ligue os terminais do sistema de alifalantes ao chassi do automóvel, e não ligue os terminais do alifalante direito aos terminais do alifalante esquerdo.
- Não tente ligar os alifalantes em paralelo.
- Não ligue nenhum sistema de alifalantes activos (com amplificadores incorporados) aos terminais dos alifalantes do aparelho. Caso o faça, poderá avariar o sistema de alifalantes activos. Portanto, não se esqueça de ligar alifalantes passivos a estes terminais.

### \*1 Nota referente à ligação da antena

Se a antena do automóvel for uma antena de tipo ISO (International Organization for Standardization), utilize o adaptador fornecido (Ⓢ) para fazer a ligação respectiva. Ligue primeiro a antena do automóvel ao adaptador fornecido e depois à ficha tipo jack de antena do sistema principal.

### \*2 Para ligação a AMP REMOTE IN do amplificador de potência adicional

Esta ligação destina-se apenas aos amplificadores. A ligação de qualquer outro sistema pode provocar avarias no aparelho.

**Connection example**  
**Conexiones de ejemplo**  
**Exempel på Kopplingschema**  
**Ligações de exemplo**

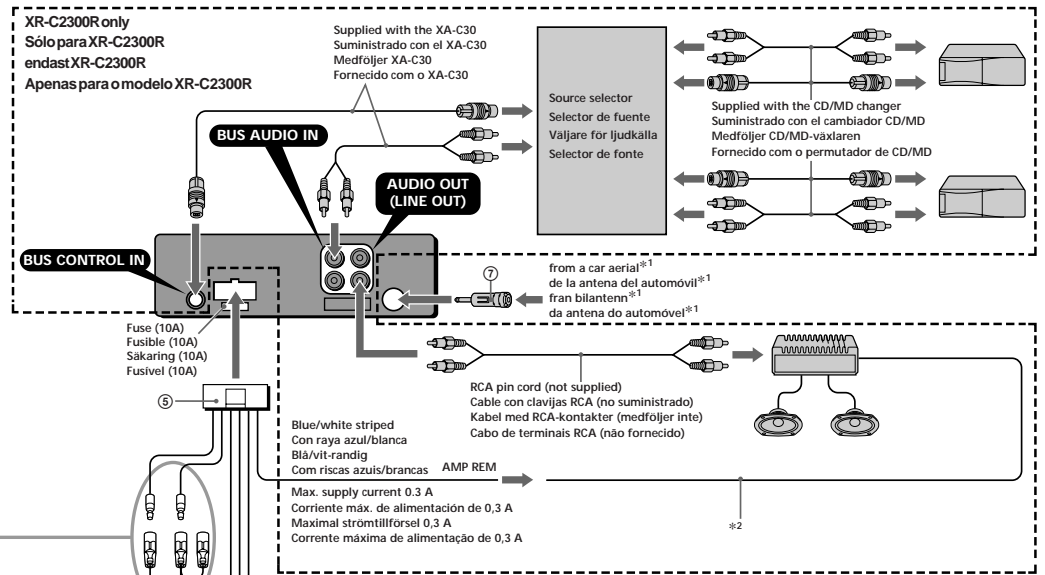

See "Power connection diagram" for details.  
 Para obtener información detallada, consulte "Diagrama de conexión de alimentación".  
 Se "Strömanslutningsschema", där finns mer information.  
 Para mais informações, consulte o "Diagrama de ligação de corrente".

to a car's auxiliary power connector  
 a un conector de alimentación auxiliar del automóvil  
 till bilens yttre strömanslutning  
 a um conector de alimentação auxiliar do automóvel

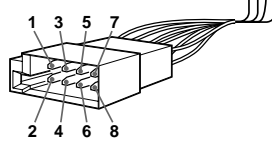
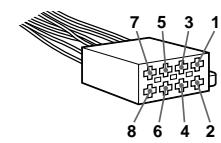

4	Yellow Amarillo Gul Amarelo	continuous power supply suministro de alimentación continua kontinuerlig strömforsörjning alimentação de corrente continua	7	Red Rojo Röd Vermelho	switched power supply suministro de alimentación conmutado switchad strömforsörjning alimentação de corrente comutada
5	Blue Azul Blå Azul	power aerial control control de antena motorizada elektrisk antenn antena eléctrica	8	Black Negro Svart Preto	earth toma de tierra jord Terra

Positions 1, 2, 3 and 6 do not have pins.  
 Las posiciones 1, 2, 3 y 6 no disponen de pines.  
 As posições 1, 2, 3 e 6 não têm pinos.  
 Positionerna 1, 2, 3 och 6 saknar stift.

1	Purple Púrpura Violett Violeta	+	Speaker, Rear, Right Altavoz, trasero, derecho Högtalare, bakre, höger Altifalante, Parte de trás, Direito	5	White Blanco Vit Branco	+	Speaker, Front, Left Altavoz, delantero, izquierdo Högtalare, framre, vänster Altifalante, Parte da frente, Esquerdo
2		-	Speaker, Rear, Right Altavoz, trasero, derecho Högtalare, bakre, höger Altifalante, Parte de trás, Direito	6		-	Speaker, Front, Left Altavoz, delantero, izquierdo Högtalare, framre, vänster Altifalante, Parte da frente, Esquerdo
3	Grey Gris Grå Cinzentou	+	Speaker, Front, Right Altavoz, delantero, derecho Högtalare, framre, höger Altifalante, Parte da frente, Direito	7	Green Verde Grön Verde	+	Speaker, Rear, Left Altavoz, trasero, izquierdo Högtalare, bakre, vänster Altifalante, Parte de trás, Esquerdo
4		-	Speaker, Front, Right Altavoz, delantero, derecho Högtalare, framre, höger Altifalante, Parte da frente, Direito	8		-	Speaker, Rear, Left Altavoz, trasero, izquierdo Högtalare, bakre, vänster Altifalante, Parte de trás, Esquerdo

Negative polarity positions 2, 4, 6, and 8 have striped cords.  
 Las posiciones de polaridad negativa 2, 4, 6 y 8 tienen cables con raya.  
 As posições 2, 4, 6 e 8 (polaridade negativa) têm cabos as riscas.  
 De negativa polpositionerna 2, 4, 6 och 8 har randiga kablar.

**Power connection diagram**

Auxiliary power connector may vary depending on the car. Check your car's auxiliary power connector diagram to make sure the connections match correctly. There are three basic types (illustrated below). You may need to switch the positions of the red and yellow leads in the car stereo's power connecting cord.

After matching the connections and switched power supply leads correctly, connect the unit to the car's power supply. If you have any questions and problems connecting your unit that are not covered in this manual, please consult the car dealer.

**Diagrama de conexión de alimentación**

El conector de alimentación auxiliar puede variar en función del automóvil. Compruebe el diagrama del conector de alimentación auxiliar del automóvil para asegurarse de que las conexiones coincidan correctamente. Existen tres tipos básicos, ilustrados a continuación. Es posible que se precise cambiar las posiciones de los cables rojo y amarillo del cable de conexión de alimentación del sistema estéreo del automóvil.

Después de hacer coincidir correctamente las conexiones y los cables de alimentación conmutada, conecte la unidad al suministro de alimentación del automóvil. Si desea realizar alguna consulta o solucionar algún problema referentes a la conexión de la unidad que no aparezcan en este manual, consulte con el concesionario automovilístico.

**Strömanslutningsschema**

Typen av yttre strömanslutning varierar från bil till bil. Kontrollera schemat till strömanslutningen så att du ansluter på rätt sätt. Det finns tre grundläggande anslutningstyper (visas nedan). Eventuellt kan du behöva byta plats på de röda och gula ledarna i bilsterens strömanslutningskabel.

Koppla kablarna för kontinuerlig respektive switchad strömforsörjning på rätt sätt och anslut sedan enheten till bilens strömanslutning. Om du får problem eller har frågor som inte besvaras i den här bruksanvisningen kan du kontakta bilåterförsäljaren.

**Diagrama de ligação de corrente**

O conector auxiliar de corrente pode variar de carro para carro. Verifique o diagrama do conector auxiliar de corrente do seu automóvel para se certificar de que as ligações estão bem feitas. Existem três tipos de conectores (ilustrados abaixo). Pode ter que mudar as posições dos fios vermelho e amarelo do cabo de ligação da alimentação do sistema estéreo do automóvel.

Depois de fazer a correspondência entre as ligações e os fios de alimentação de corrente comutada, ligue o aparelho à fonte de alimentação do carro. Se tiver alguma dúvida ou problema relacionado com o aparelho que não esteja incluído neste manual, consulte o concessionário.

Auxiliary power connector  
 Conector de alimentación auxiliar  
 Yttre strömanslutning  
 Conector auxiliar de corrente

**A**

4	Yellow Amarillo Gul Amarelo	continuous power supply suministro de alimentación continua kontinuerlig strömforsörjning alimentação de corrente continua
7	Red Rojo Röd Vermelho	switched power supply suministro de alimentación conmutado switchad strömforsörjning alimentação de corrente comutada

**B**





4	Yellow Amarillo Gul Amarelo	switched power supply suministro conmutado de alimentación switchad strömforsörjning alimentação de corrente comutada
7	Red Rojo Röd Vermelho	continuous power supply suministro de alimentación continua kontinuerlig strömforsörjning alimentação de corrente continua

**C**

the car without ACC position  
 automóvil sin posición ACC  
 bil utan ACC-läge  
 o carro sem posição ACC

**Connection diagram (XR-C2300R only)**  
**Diagrama de conexiones (sólo para XR-C2300R)**  
**Kopplingschema (endast XR-C2300R)**  
**Diagrama de ligações (Apenas para o modelo XR-C2300R)**

**Equipment used in illustrations (not supplied)**  
**Equipo utilizado en las ilustraciones (no suministrado)**  
**Utrustning som visas i illustrationer (medföljer inte)**  
**Equipamento utilizado nas ilustrações (não fornecido)**

	Front speaker Altavoz delantero Fråmre högtalare Altifalante dianteiro		Power amplifier Amplificador de potencia Effektförstärkare Amplificador de potência
	Rear speaker Altavoz trasero Bakre högtalare Altifalante traseiro		CD/MD changer Cambiador de CD/MD CD/MD-skivväxlare Permutador CD/MD

*For connecting two or more changers, the source selector XA-C30 (optional) is necessary.  
 Si desea conectar dos o más cambiadores, necesitará el selector de fuente XA-C30 (opcional).  
 För anslutning av två eller flera växlare krävs väljaren XA-C30 (tillval).  
 Para ligar dois ou mais permutadores, é necessário o selector de fonte XA-C30 (opcional).*

**Caution**

Cautionary notice for handling the bracket ①.  
 Handle the bracket carefully to avoid injuring your fingers.

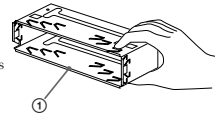

**Precaución**

Advertencia sobre la manipulación del soporte ①.  
 Tenga mucho cuidado al manipular el soporte para evitar posibles lesiones en los dedos.

**Varning**

Att observera angående konsolen ①.  
 Hantera konsolen med största aktsamhet så att du inte skadar fingrarna.

**Cuidado**

Aviso sobre as precauções a tomar no manuseamento do suporte ①.  
 Pegue no suporte com cuidado para não magoar os dedos.

**A**

**B**

**Notes**

- Be sure to connect the earth cord before connecting the amplifier.
- If you connect an optional power amplifier and do not use the built-in amplifier, the beep sound will be deactivated.

**Notas**

- Asegúrese de conectar primero el cable de puesta a masa antes de realizar la conexión al amplificador.
- Si conecta un amplificador de potencia opcional y no utiliza el incorporado, los pitidos se desactivarán.

**Observeira**

- Var noga med att först ansluta jorden, innan du ansluter förstärkaren.
- Om du väljer att använda en annan förstärkare i stället för den inbyggda, kommer ljudsignalen att avaktiveras.

**Notas**

- Antes de fazer a ligação ao amplificador tem de ligar primeiro o cabo de ligação à terra.
- Se ligar um amplificador de potência opcional e não utilizar o amplificador integrado, desactiva o sinal sonoro.

**C**

**Reset button**

When the installation and connections are complete, be sure to press the reset button with a ballpoint pen, etc.

**Nollställningsknappen**

Kom ihåg att använda en penna eller något annat spetsigt föremål för att trycka på nollställningsknappen när anslutningen och monteringen är klar.

**Botón de reposición**

Cuando finalice la instalación y las conexiones, cerciórese de presionar el botón de reposición con un bolígrafo, etc.

**Botão de reinicialização**

Quando terminar a instalação e as ligações, não se esqueça de carregar no botão de reinicialização com a ponta de uma caneta, etc.

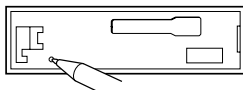

## SECTION 2 DISASSEMBLY

**Note:** Follow the disassembly procedure in the numerical order given.

### SUB PANEL

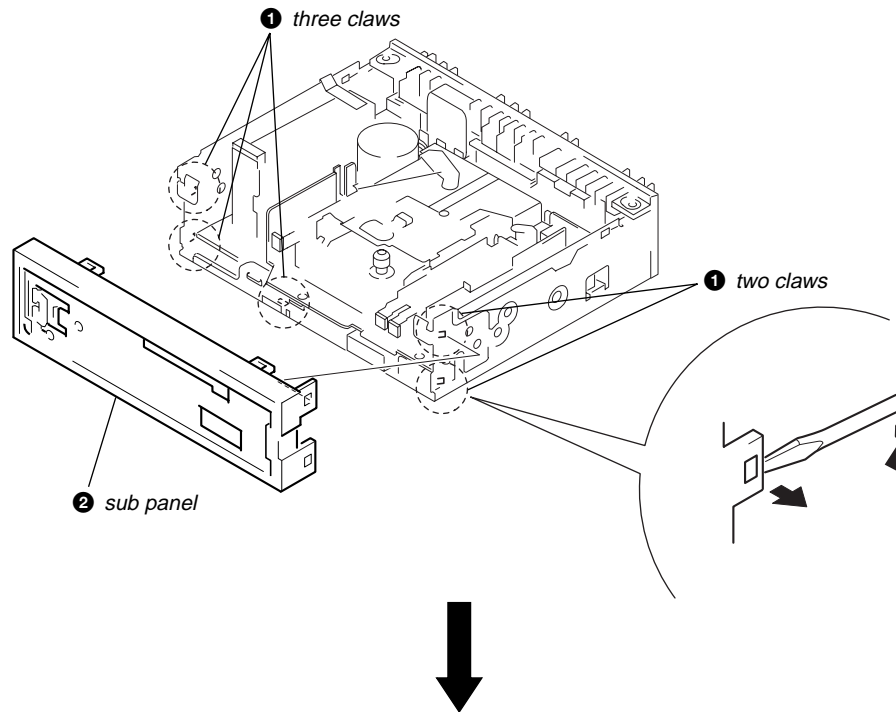

### MECHANISM DECK (MG-36SZ10-32)

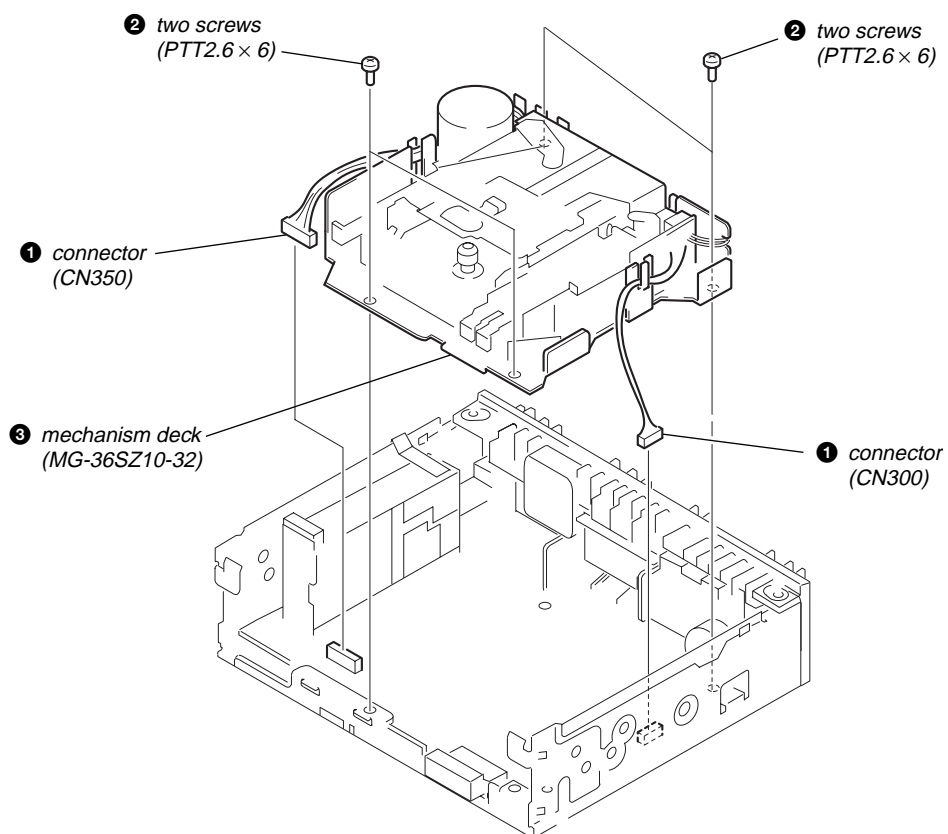

## MAIN BOARD

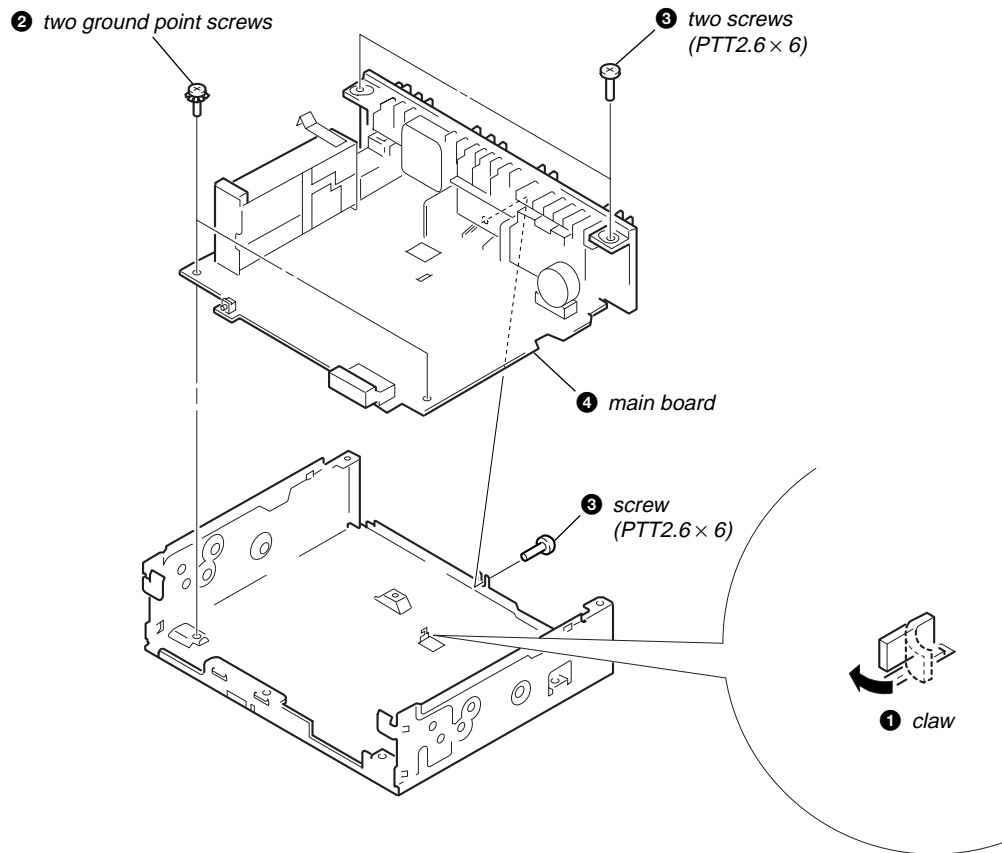

## BRACKET (MD)

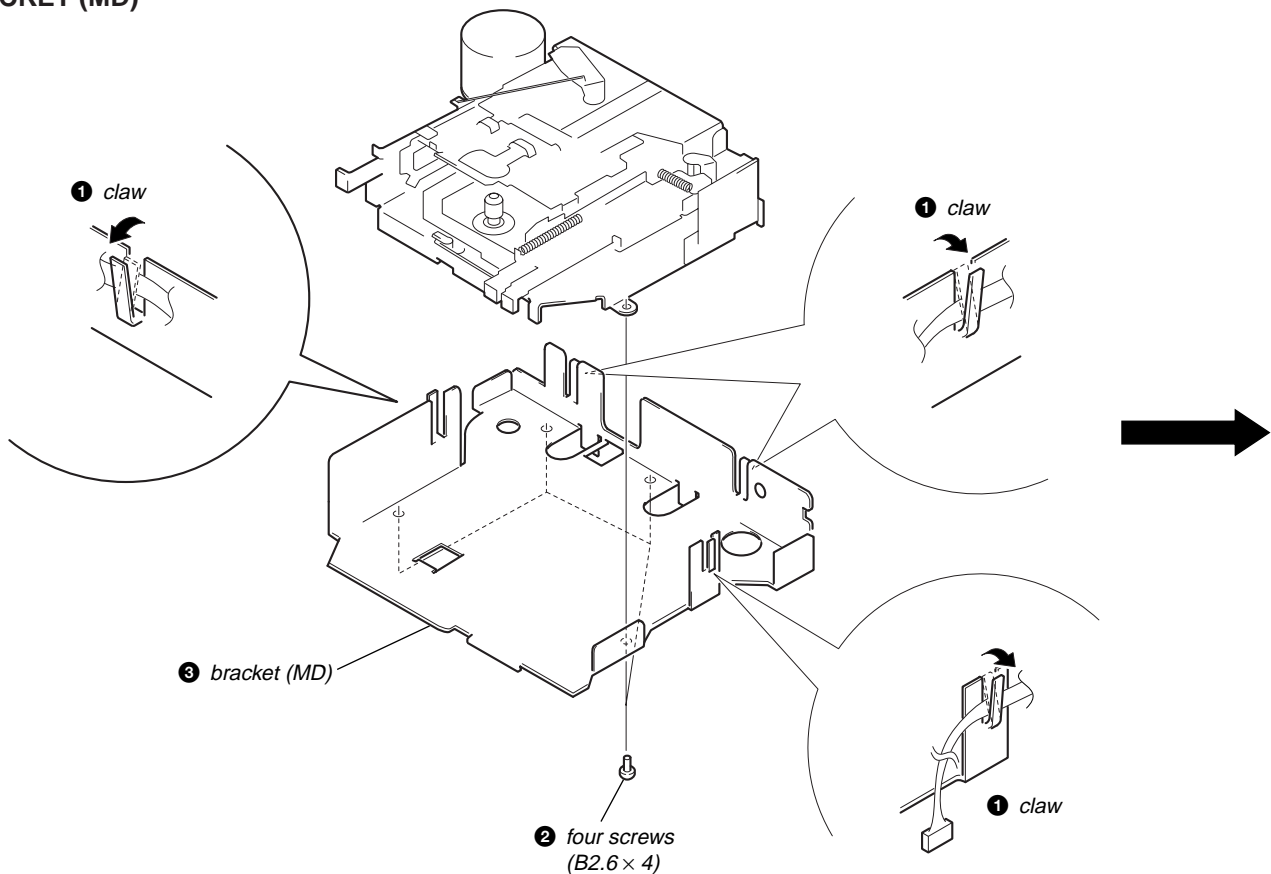

# HEAT SINK

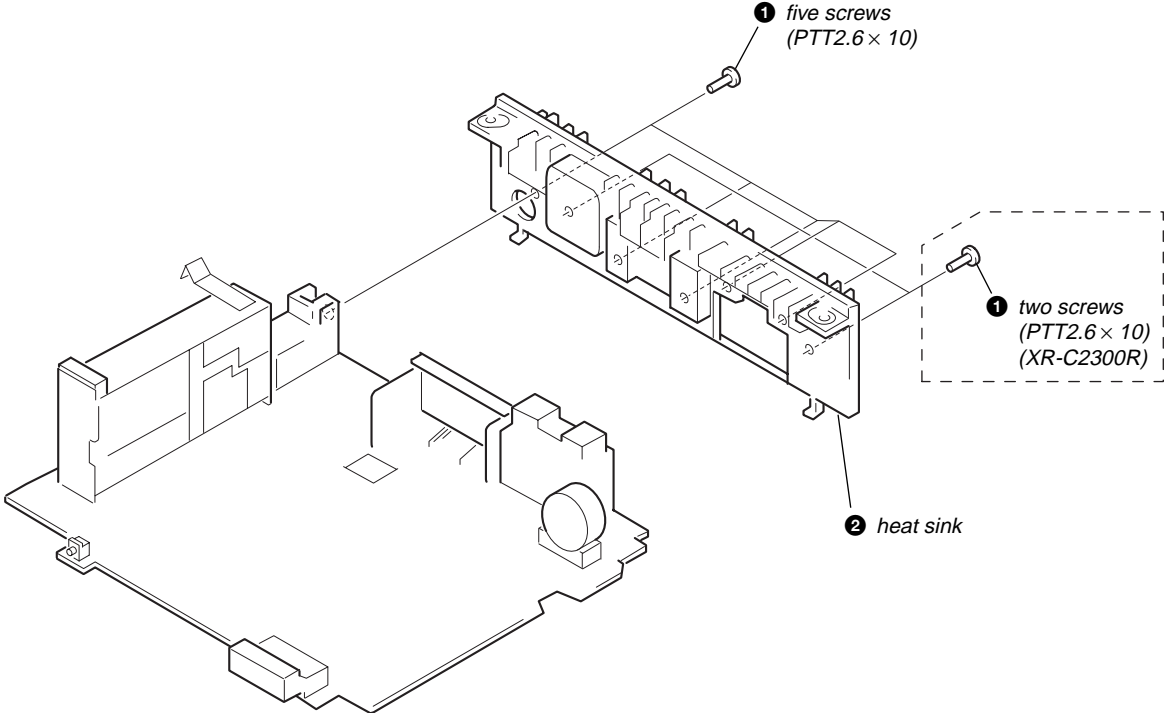

# MOTOR ASS'Y (CAPSTAN/REEL) (M901)

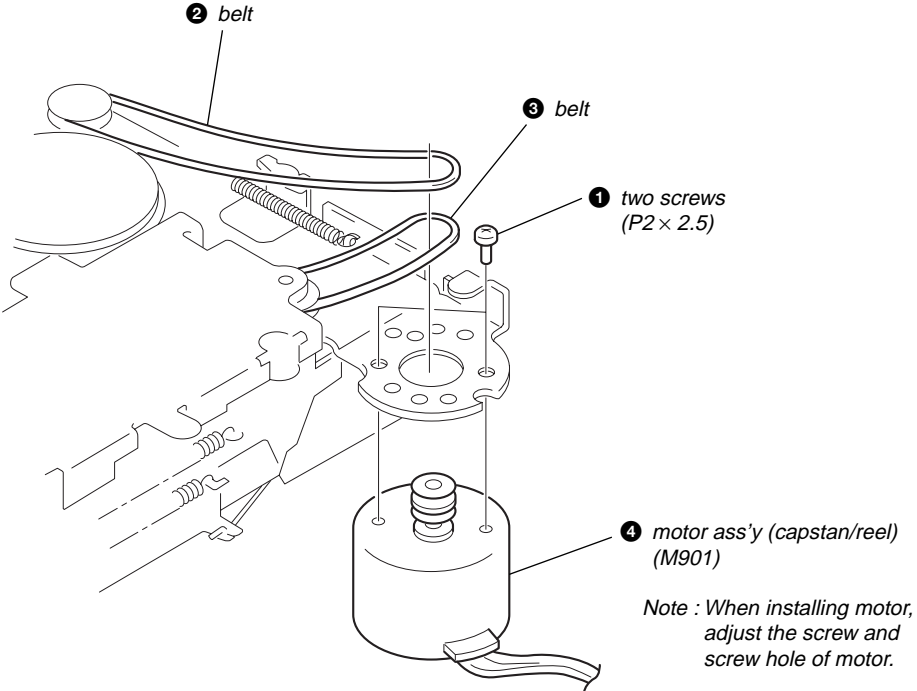

## SECTION 3 MECHANICAL ADJUSTMENTS

1. Clean the following parts with a denatured-alcohol-moistened swab:
 

playback head	pinch roller
rubber belt	capstan
idler	
2. Demagnetize the playback head with a head demagnetizer.
3. Do not use a magnetized screwdriver for the adjustments.
4. The adjustments should be performed with the power supply voltage (14.4 V) unless otherwise noted.

### •Torque Measurement

Mode	Torque Meter	Meter Reading
Forward	CQ-102C	2.46 – 5.39 mN•m (25 – 55 g•cm) (0.35 – 0.76 oz•inch)
Forward Back Tension	CQ-102C	0.15 – 0.39 mN•m (1.5 – 4 g•cm) (0.02 – 0.06 oz•inch)
Reverse	CQ-102RC	2.46 – 5.39 mN•m (25 – 55 g•cm) (0.35 – 0.76 oz•inch)
Reverse Back Tension	CQ-102RC	0.15– 0.39 mN•m (1.5 – 4 g•cm) (0.02 – 0.06 oz•inch)
FF, REW	CQ-201B	4.91 – 14.70 mN•m (50 – 150 g•cm) (0.69 – 2.08 oz•inch)

### •Tape Tension Measurement

Mode	Tension Meter	Meter Reading
Forward	CQ-403A	more than 5.89 mN•m (more than 60 g) (more than 2.12 oz)
Reverse	CQ-403R	

## SECTION 4 ELECTRICAL ADJUSTMENTS

### TEST MODE

This set have the test mode function. In the test mode, FM Auto Seek/Stop Level, FM RDS S-Meter adjustments and MW Auto Seek/Stop Level check can be performed easier than it in ordinary procedure.

<Set the Test Mode>

1. Turn ON the regulated power supply. (All LEDs on the set lights up, and the clock is displayed.)
 

**Note:** Press the **[OFF]** button, if the clock is not displayed.
2. Push the preset **[4]** button.
3. Push the preset **[5]** button.
4. Press the preset **[1]** button for more than two seconds.
5. Then the display indicates all lights, the test mode is set.

<Release the Test mode>

1. Push the **[OFF]** button.

## TAPE DECK SECTION

0 dB = 0.775 V

- The adjustments should be performed in the order given in this service manual.
- The adjustments should be performed for both L-CH and R-CH.

### Test Tape

Type	Signal	Used for
P-4-A063	6.3 kHz, -10 dB	head azimuth adjustment
WS-48A	3 kHz, 0 dB	tape speed adjustment

### PB Head Azimuth Adjustment

#### Procedure:

- Put the set into the FWD PB mode.

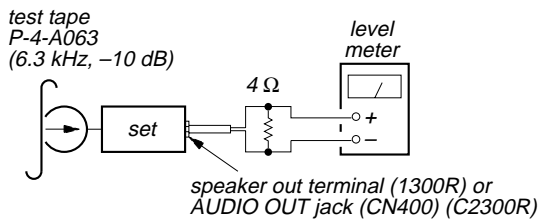

- Turn the screw and check the output peak value. Adjust the screw so that the peak value in channels L and R coincides within 2 dB.

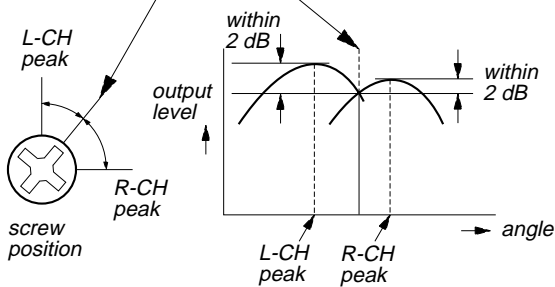

- Check the phase in the FWD PB mode.

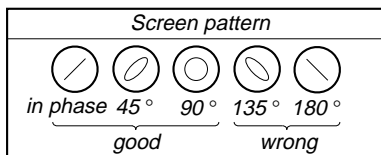
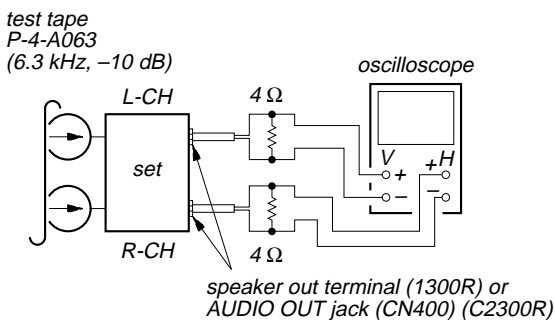

- Repeat the above adjustment for the REV PB mode.
- Check that output level difference between FWD PB mode and REV PB mode is within 4 dB.

### Adjustment Location: PB head

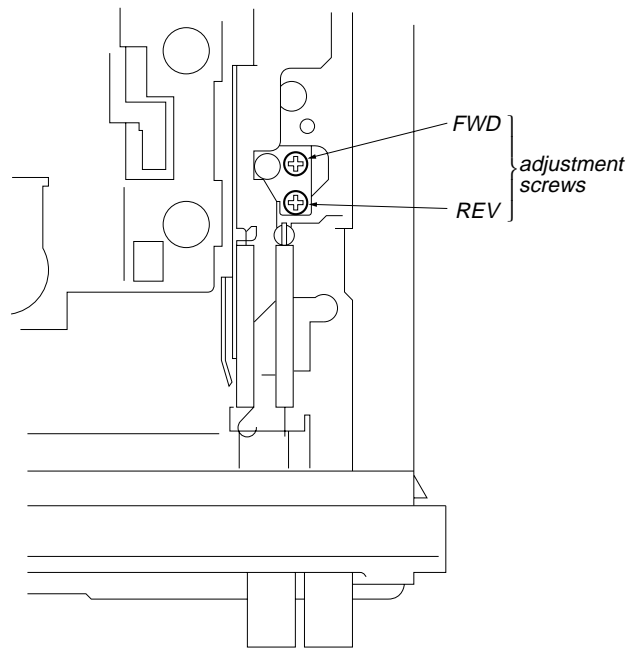

See the adjustment location from on page 16 for the adjustment.

### Tape Speed Adjustment

#### Setting:

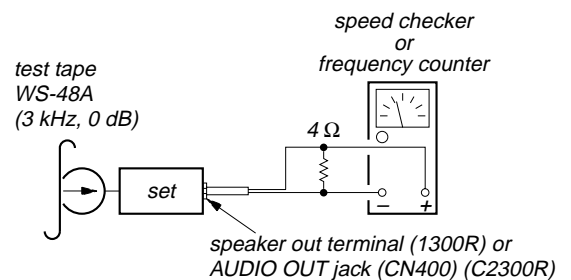

#### Procedure:

- Put the set into the FWD PB mode.
- Adjust adjustment resistor for inside capstan motor so that the reading on the speed checker or frequency counter becomes in specification.

#### Specification: Constant speed

Speed checker	Frequency counter
-2 to +3%	2,940 to 3,090 Hz

Adjustment Location: See page 16.

## TUNER SECTION

0 dB=1  $\mu$ V

### Cautions during repair

When the tuner unit is defective, replace it by a new one because its internal block is difficult to repair.

**Note:** Adjust the tuner section in the sequence shown below.

1. FM Auto Seek/Stop Level Adjustment
2. FM Stereo Separation Adjustment
3. FM RDS S-Meter Adjustment
4. MW Auto Seek/Stop Level Adjustment

### FM Auto Seek/Stop Level Adjustment

**Setting:**

**TUNER** (1300R) or **SOURCE** (C2300R) button: FM

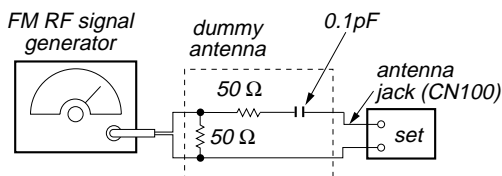

Carrier frequency : 98.0 MHz  
 Output level : 22 dB (12.6  $\mu$ V)  
 Mode : mono  
 Modulation : 1 kHz, 22.5 kHz deviation (30%)

### Procedure:

1. Set to the test mode. (See page 12)
2. Push the **TUNER** (1300R) or **SOURCE** (C2300R) button and set to FM.

Display

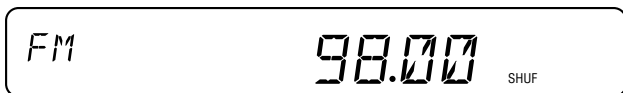

3. Adjust with the volume RV2 on TU100 so that the "FM" indication turns to "FM0" indication on the display window. But, in case of already indicated "FM0", turn the RV2 so that put out light "0" indication and adjustment.

Display

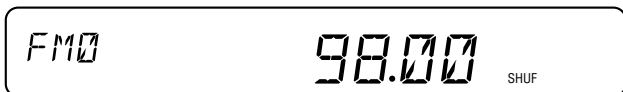

**Adjustment Location:** See page 16.

### FM Stereo Separation Adjustment

**Setting:**

**TUNER** (1300R) or **SOURCE** (C2300R) button: FM

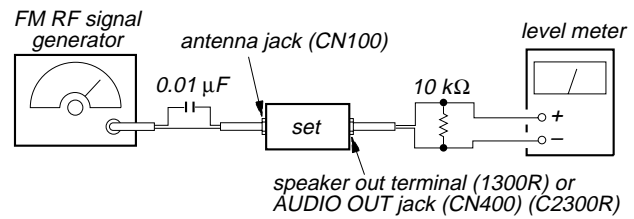

Carrier frequency : 98.0 MHz  
 Output level : 70 dB (3.2 mV)  
 Mode : stereo  
 Modulation : main: 1 kHz, 20 kHz deviation (26.7%)  
 sub: 1 kHz, 20 kHz deviation (26.7%)  
 19 kHz pilot: 7.5 kHz deviation (10%)

### Procedure:

FM Stereo signal generator output channel	Level meter connection	Level meter reading (dB)
L-CH	L-CH	Ⓐ
R-CH	L-CH	Ⓑ Adjust RV4 on TU100 for minimum reading.
R-CH	R-CH	Ⓒ
L-CH	R-CH	Ⓓ Adjust RV4 on TU100 for minimum reading.

L-CH Stereo separation: Ⓐ-Ⓑ

R-CH Stereo separation: Ⓒ-Ⓓ

The separations of both channels should be equal.

**Specification:** Separation more than 30 dB

**Adjustment Location:** See page 16.

### FM RDS S-Meter Adjustment

#### Setting:

[TUNER] (1300R) or [SOURCE] (C2300R) button: FM

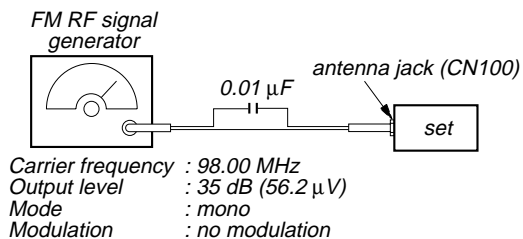

#### Procedure:

1. Set to the test mode. (See page 12)
2. Push the [TUNER] (1300R) or [SOURCE] (C2300R) button and set to FM.



3. Push the [6] button.
4. Adjust VR100 on main board so that the display indication is "10.2".

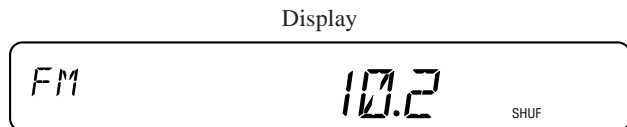

**Specification:** Display indication: 10.0 to 10.4

**Adjustment Location:** See page 16.

### MW Auto Seek/Stop Level Adjustment

Make this adjustment after "FM Auto Seek/Stop Level Adjustment".

#### Setting:

[TUNER] (1300R) or [SOURCE] (C2300R) button: MW

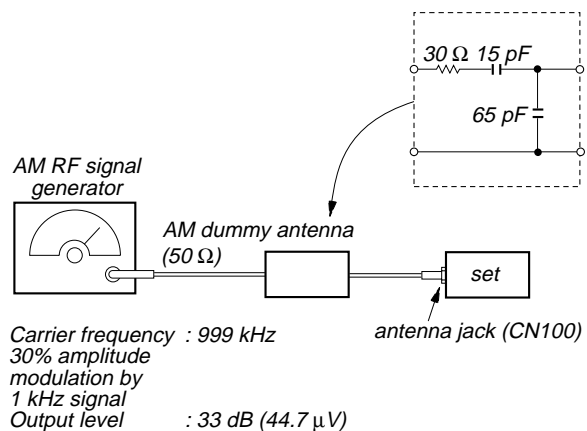

#### Procedure:

1. Set to the test mode. (See page 12)
2. Push the [TUNER] (1300R) or [SOURCE] (C2300R) button and set to FM.
3. Push the [MODE] button and set to MW.

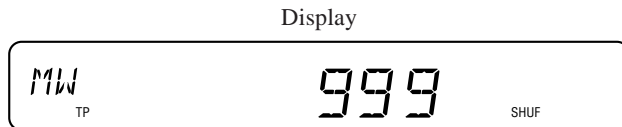

4. Adjust with the volume RV1 on TU100 so that the "MW" indication turns to "MW0" indication on the display window. But, in case of already indicated "MW0", turn the RV1 so that put out light "0" indication and adjustment.

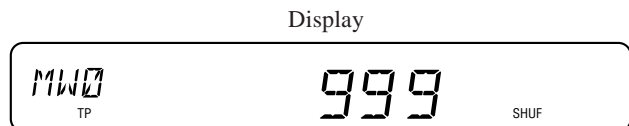

**Adjustment Location:** See page 16.

**Adjustment Location:**

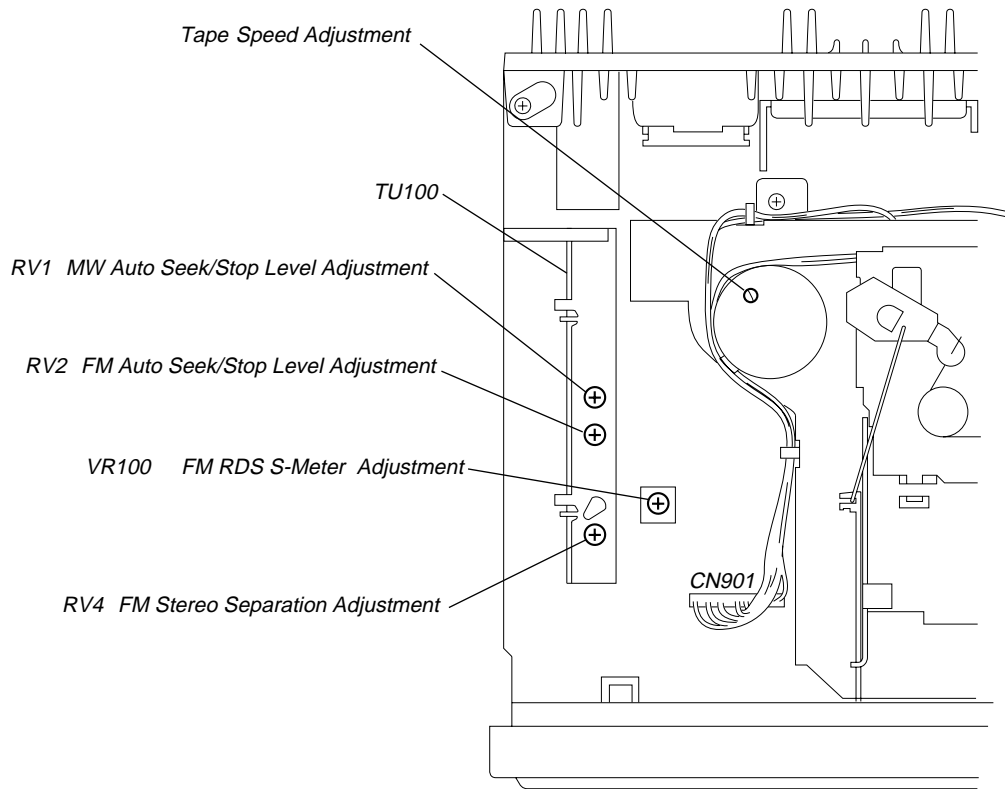

## SECTION 5 DIAGRAMS

### 5-1. NOTE FOR PRINTED WIRING BOARDS AND SCHEMATIC DIAGRAMS

#### Note on Printed Wiring Board:

- : parts extracted from the component side.
- : parts extracted from the conductor side.
- : Pattern from the side which enables seeing.  
(The other layers' patterns are not indicated.)

**Caution:**  
 Pattern face side: Parts on the pattern face side seen from the pattern face are indicated.  
 (Conductor Side)  
 Parts face side: Parts on the parts face side seen from the parts face are indicated.  
 (Component Side)

#### Note on Schematic Diagram:

- All capacitors are in  $\mu\text{F}$  unless otherwise noted. pF:  $\mu\text{F}$  50 WV or less are not indicated except for electrolytics and tantalums.
- All resistors are in  $\Omega$  and  $\frac{1}{4} \text{W}$  or less unless otherwise specified.
- $\triangle$  : internal component.
- : panel designation.
- : B+ Line.
- : adjustment for repair.
- Power voltage is dc 14.4V and fed with regulated dc power supply from ACC and BATT cords.
- Voltages and waveforms are dc with respect to ground under no-signal (detuned) conditions.
- no mark : FM
- ( ) : MW(LW)
- << >> : TAPE PLAYBACK
- Voltages are taken with a VOM (Input impedance 10 M $\Omega$ ). Voltage variations may be noted due to normal production tolerances.
- Waveforms are taken with a oscilloscope. Voltage variations may be noted due to normal production tolerances.
- Circled numbers refer to waveforms.
- Signal path.
  - : FM
  - : MW(LW)
  - : BUS AUDIO IN
  - : TAPE PLAYBACK
- Abbreviation  
 AMBER : Amber illumination type  
 GREEN : Green illumination type

#### • Waveforms – MAIN Board –

##### ① IC130 ② (OSCOUT) (MW/LW)

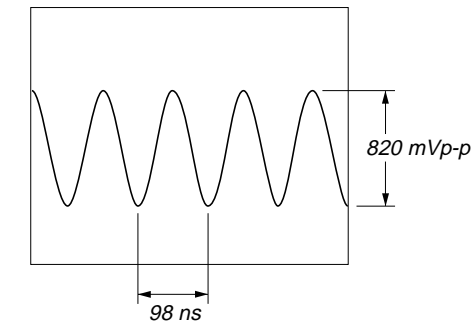

##### ② IC200 ⑤ (OSCI)

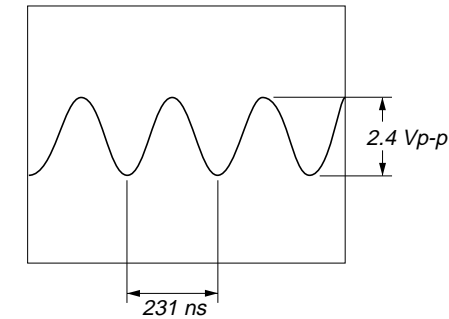

##### ③ IC1 ⑦④ (X0A)

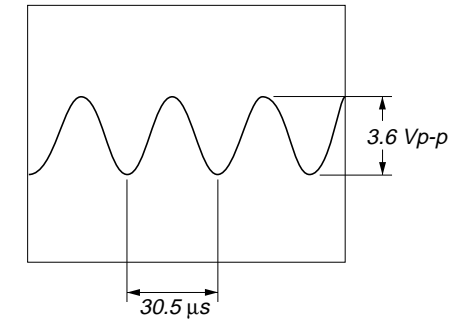

##### ④ IC1 ⑧③ (X1)

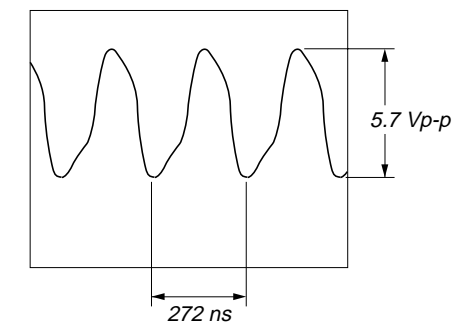

5-2. PRINTED WIRING BOARD – MAIN Board (Component Side) –

• Semiconductor Location

Ref. No.	Location
D1	I-9
D614	F-9
D617	F-10
IC1	I-7
IC2	I-5
IC130	E-4
IC200	G-4
IC201	H-4
IC300	G-10
IC400	F-8
IC800	E-11
Q1	I-6
Q2	I-6
Q101	D-5
Q102	D-4
Q103	E-5
Q104	E-4
Q105	D-4
Q106	E-5
Q160	G-6
Q161	G-6
Q162	G-6
Q163	G-6
Q200	H-2
Q201	H-5
Q400	F-5
Q401	F-5
Q402	F-6
Q403	F-6
Q600	G-10
Q601	F-10
Q602	F-11
Q603	F-11
Q604	F-11
Q605	F-10
Q700	E-9
Q701	E-10
Q702	D-9
Q705	D-8
Q706	E-8
Q708	I-10
Q710	I-4
Q712	E-10



5-3. PRINTED WIRING BOARD – MAIN Board (Conductor Side) –

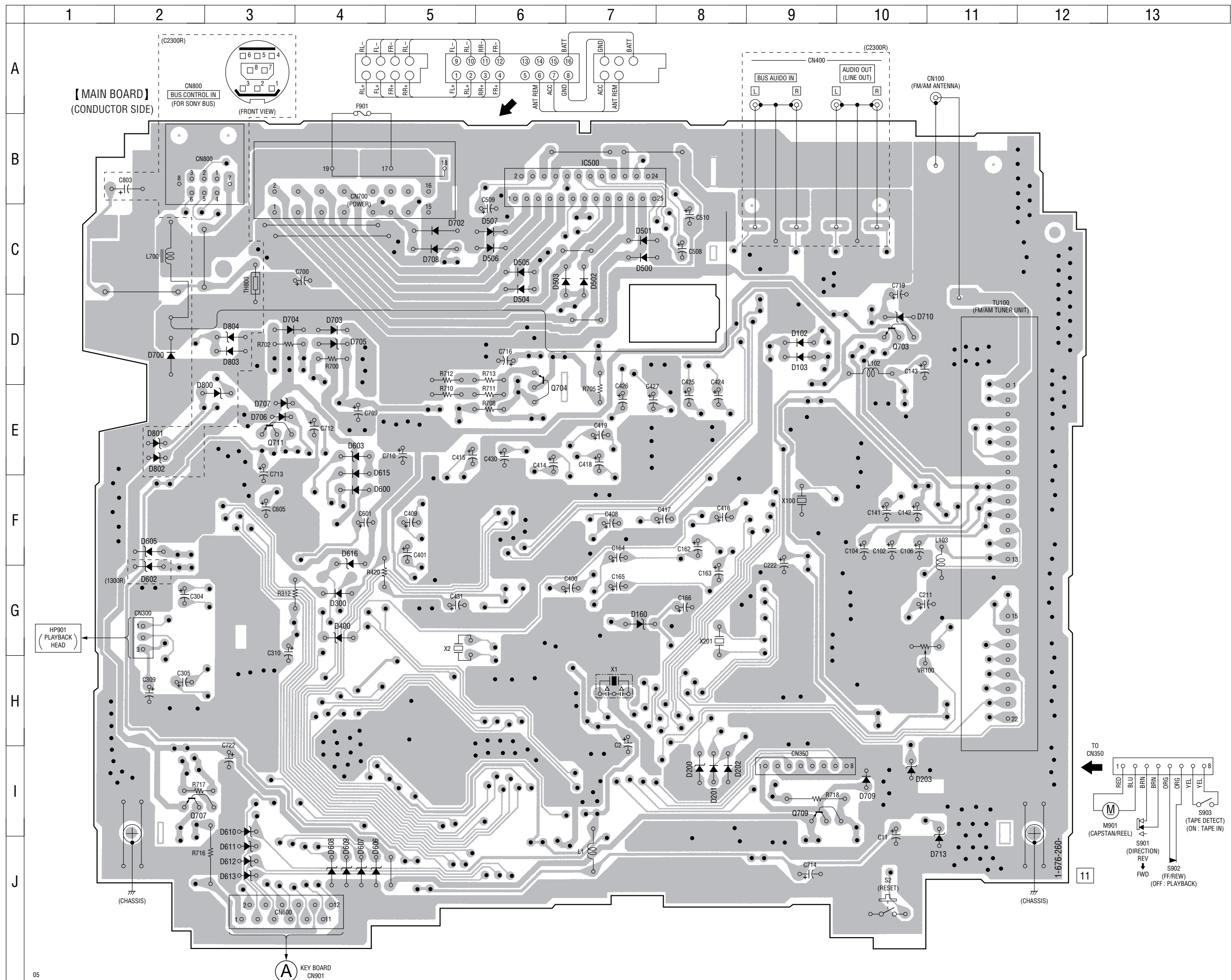

• Semiconductor Location

Ref. No.	Location
D102	D-9
D103	D-9
D160	G-7
D200	I-8
D201	I-8
D202	I-8
D203	I-10
D300	G-4
D400	G-4
D500	C-7
D501	C-7
D502	C-7
D503	C-6
D504	C-6
D505	C-6
D506	C-6
D507	C-6
D600	F-4
D602	F-2
D603	E-4
D605	F-2
D606	J-4
D607	J-4
D608	J-4
D609	J-4
D610	I-3
D611	J-3
D612	J-3
D613	J-3
D615	E-4
D616	F-4
D700	D-2
D702	C-5
D703	D-4
D704	D-3
D705	D-4
D706	E-3
D707	E-3
D708	C-5
D709	I-10
D710	D-10
D713	J-11
D800	E-3
D801	E-2
D802	E-2
D803	D-3
D804	D-3
IC500	B-7
Q703	D-10
Q704	E-6
Q707	I-2
Q709	I-9
Q711	E-3

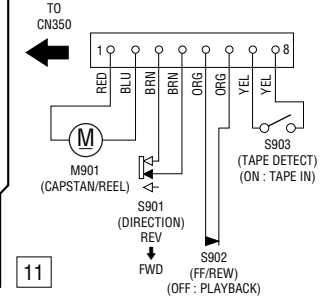

(A) KEY BOARD CN901  
(Page 22)

5-4. SCHEMATIC DIAGRAM - MAIN Board (1/2) - • See page 17 for Waveforms. • See page 24 for IC Block Diagrams.

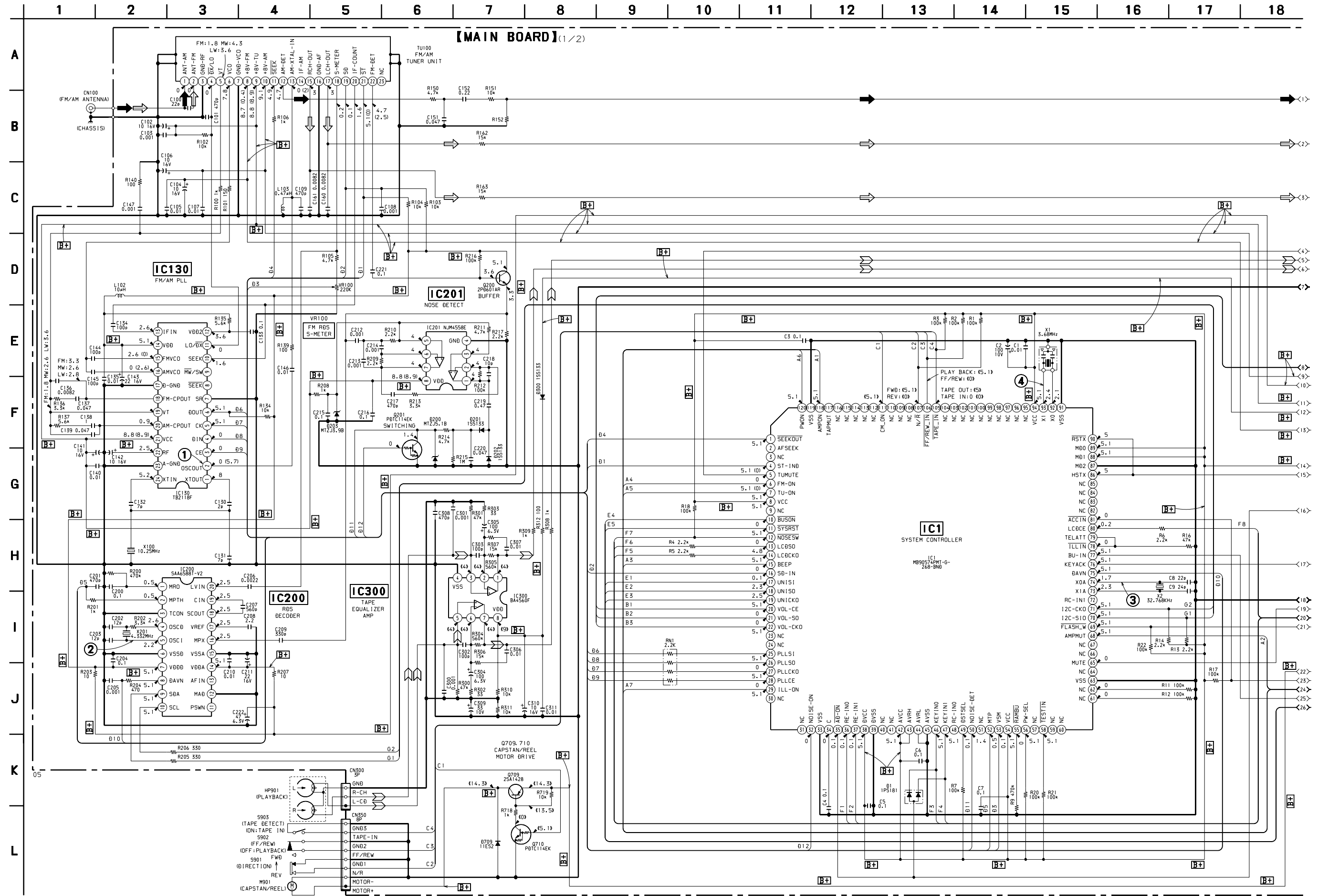

5-5. SCHEMATIC DIAGRAM – MAIN Board (2/2) – • See page 24 for IC Block Diagrams.

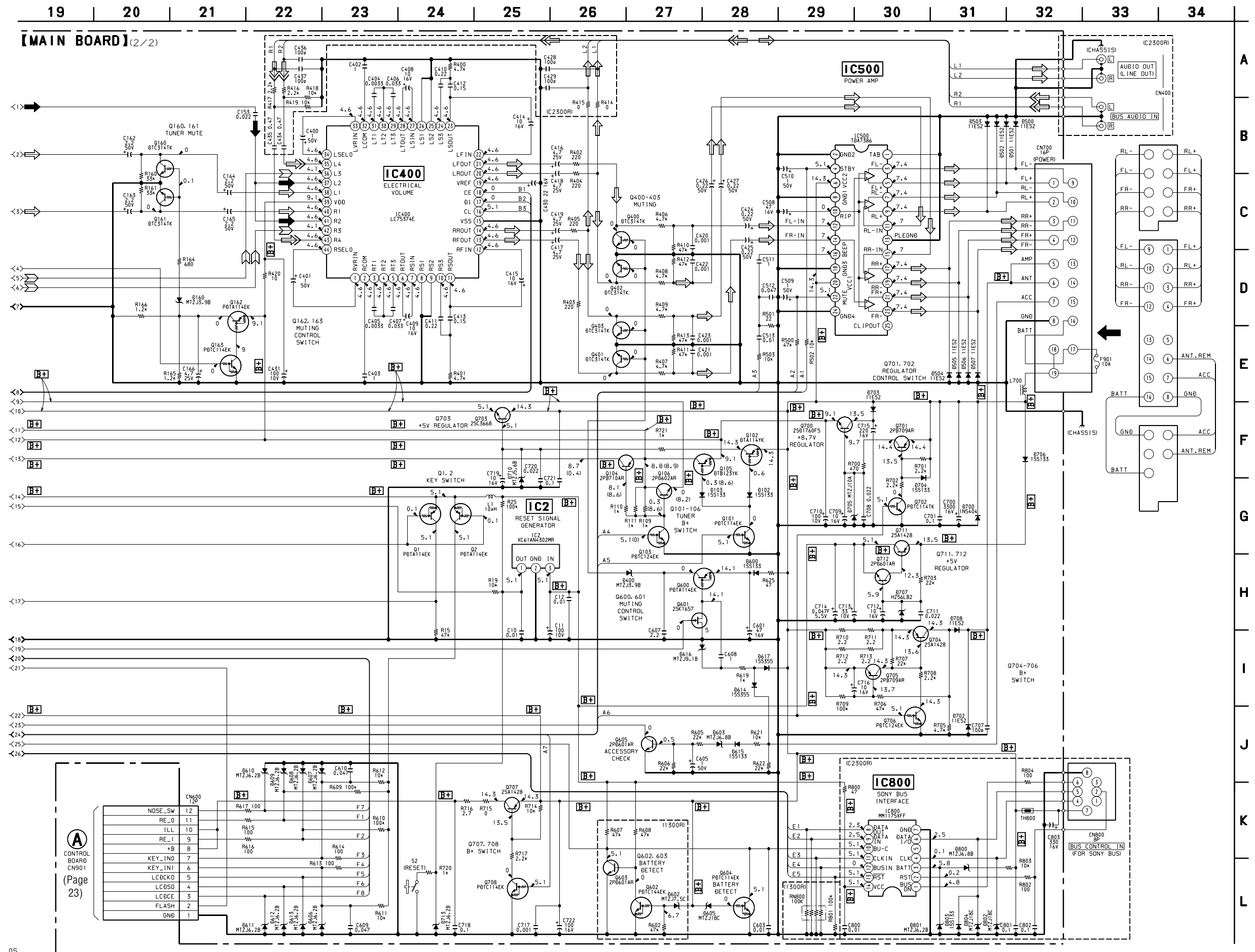

5-6. PRINTED WIRING BOARD – CONTROL Board –

• Semiconductor Location

Ref. No.	Location
D900	F-11
D901	F-11
D902	F-10
D903	C-3
D904	B-3
D905	B-3
D906	C-4
D907	A-4
D908	A-3
D910	E-4
IC900	E-8

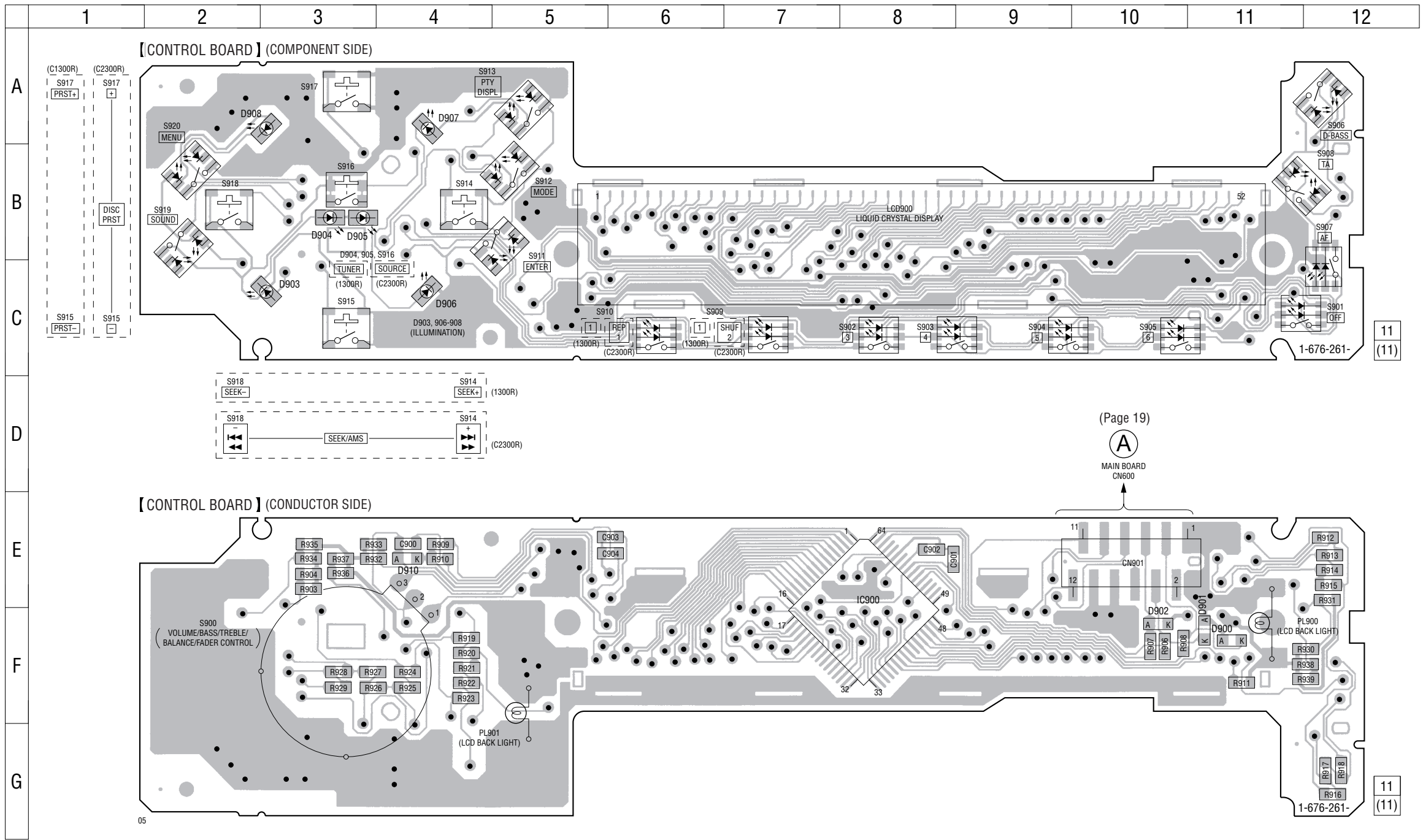

(Page 19)

(A)

MAIN BOARD

CN600

11  
(11)

11  
(11)

5-7. SCHEMATIC DIAGRAM - CONTROL Board -

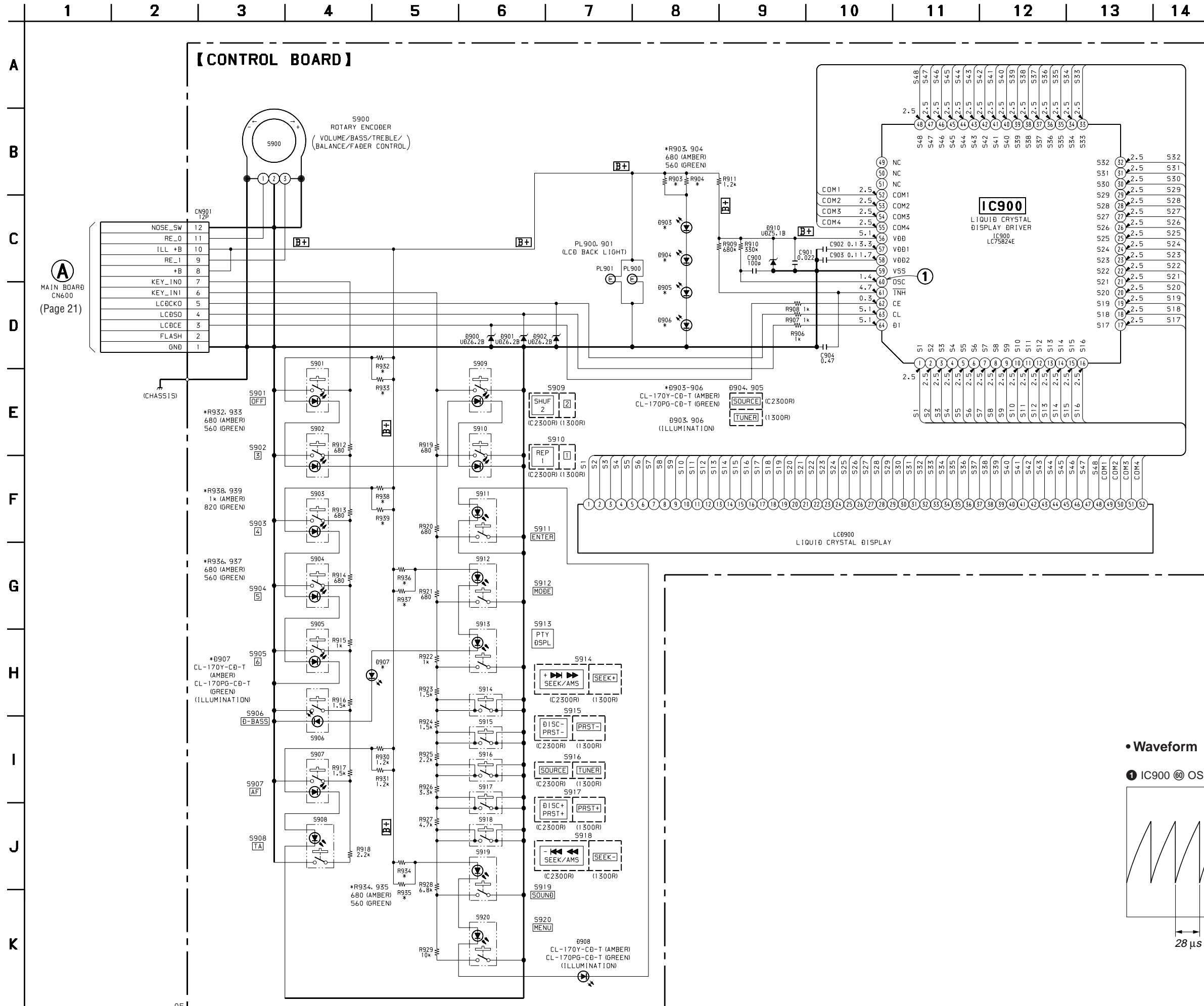

• Waveform

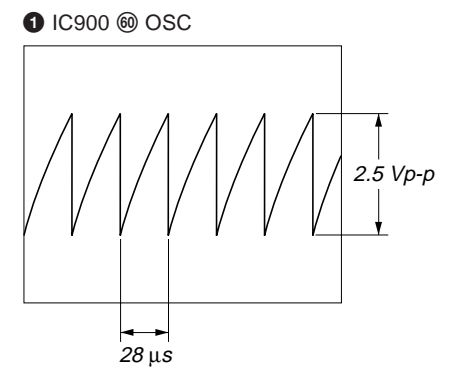

• IC Block Diagrams  
– MAIN Board –

IC130 TB2118F-EL-S

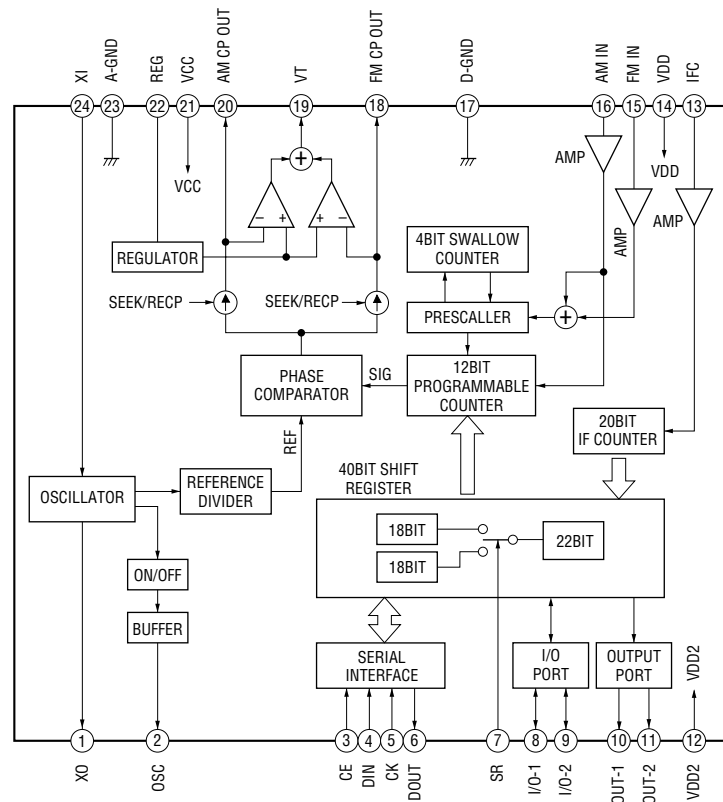

IC400 LC75374E

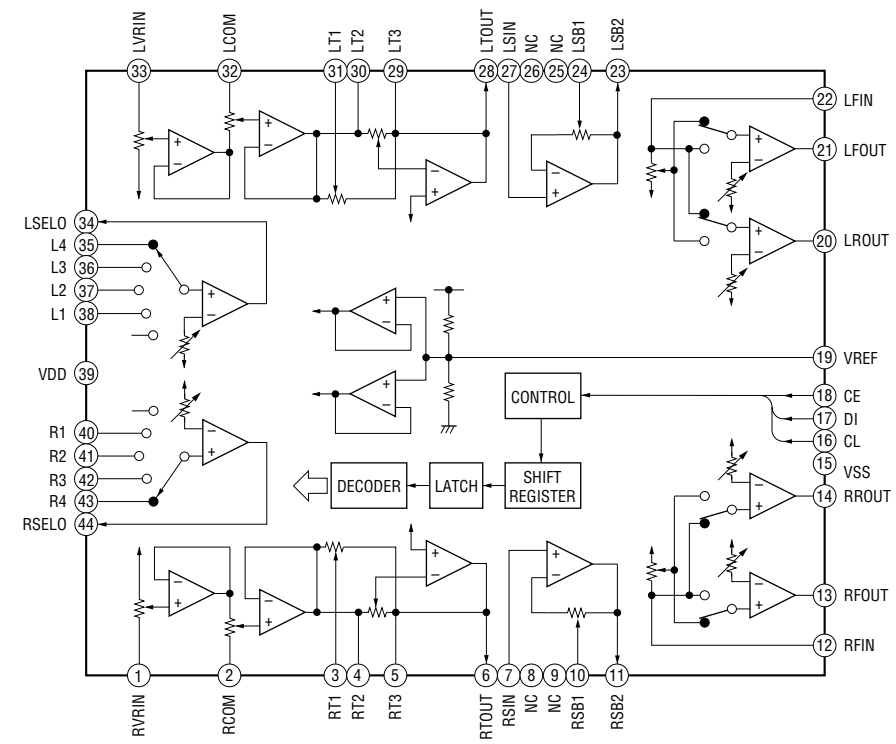

IC200 SAA6588T/V2-118

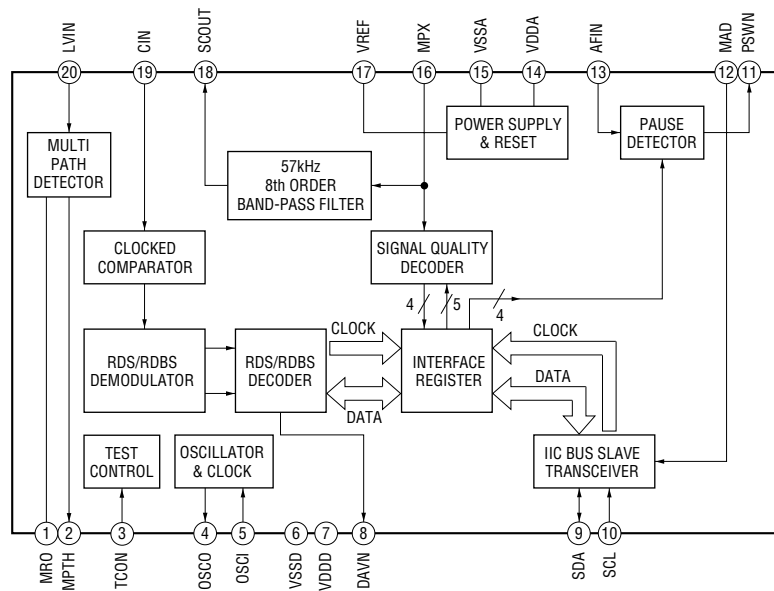

IC800 MM1175XFF

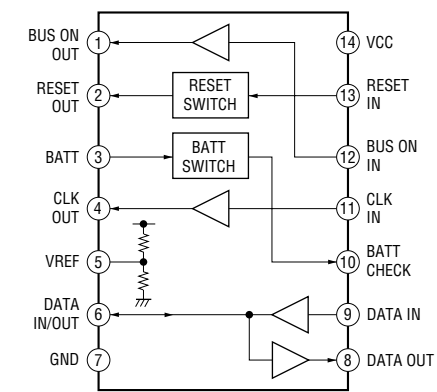

## 5-8. IC PIN FUNCTION DESCRIPTION

### • MAIN BOARD IC1 MB90574PMT-G-268-BND (SYSTEM CONTROLLER)

Pin No.	Pin Name	I/O	Description
1	<u>SEEKOUT</u>	O	Seek control signal output to the FM/AM tuner unit (TU100) AM mode: Used for IF count output/SD output request/AGC cut at SEEK or BTM FM mode: Used for SD speed up at SEEK, BTM, or AF “L” is output at tuner off
2	AFSEEK	O	PLL low-pass filter time constant selection signal output at AF SEEK “H” is output when AF SEEK Not used (open)
3	NC	O	Not used (open)
4	ST-IND	I/O	FM stereo broadcasting detection signal input from the FM/AM tuner unit (TU100), or forced monaural control signal output to the FM/AM tuner unit (TU100) “L” is input in the FM stereo mode, or “L” is output in the forced monaural mode
5	TUMUTE	O	Muting on/off control signal output of the FM and AM tuner signal “H”: muting on
6	FM-ON	O	FM system power supply on/off control signal output terminal “L”: AM power on, “H”: FM power on
7	TU-ON	O	Tuner system power supply on/off control signal output terminal “H”: tuner power on
8	VCC	—	Power supply terminal (+5V)
9	NC	O	Not used (open)
10	<u>BUSON</u>	O	Bus on/off control signal output to the SONY bus interface (IC800) “L”: bus on Used for the XR-C2300R only
11	<u>SYSRST</u>	O	Reset signal output to the SONY bus interface (IC800) “L”: reset Used for the XR-C2300R only
12	<u>NOSESW</u>	I	Front panel block remove/attach detection signal input terminal “L”: front panel is attached
13	LCDSO	O	Serial data output to the liquid crystal display driver (IC900)
14	LCDCKO	O	Serial data transfer clock signal output to the liquid crystal display driver (IC900)
15	BEEP	O	Beep sound drive signal output terminal
16	SD-IN	I	Signal detector input from the FM/AM tuner unit (TU100) Stop level for SEEK, SCAN, etc. is determined SD is present at input of “H”
17	UNISI	I	Serial data input from the SONY bus interface (IC800) Used for the XR-C2300R only
18	UNISO	O	Serial data output to the SONY bus interface (IC800) Used for the XR-C2300R only
19	UNICKO	O	Serial data transfer clock signal output to the SONY bus interface (IC800) Used for the XR-C2300R only
20	VOL-CE	O	Chip enable signal output to the electrical volume (IC400)
21	VOL-SO	O	Serial data output to the electrical volume (IC400)
22	VOL-CKO	O	Serial data transfer clock signal output to the electrical volume (IC400)
23, 24	NC	O	Not used (open)
25	PLLSI	I	PLL serial data input from the FM/AM PLL (IC130)
26	PLLSO	O	PLL serial data output to the FM/AM PLL (IC130)
27	PLLCKO	O	PLL serial data transfer clock signal output to the FM/AM PLL (IC130)
28	PLLCE	O	PLL chip enable signal output to the FM/AM PLL (IC130) “H” active
29	ILL-ON	O	Power on/off control signal output of the illumination LED and liquid crystal display driver (IC900) “H”: power on
30, 31	NC	O	Not used (open)
32	NOISE-ON	O	Discharge control signal output for the noise detection circuit “H”: discharge
33	VSS	—	Ground terminal
34	C	—	Connected to coupling capacitor for the power supply
35	<u>AD-ON</u>	O	A/D converter power control signal output terminal When the KEYACK (pin ⑦) that controls reference voltage power for key A/D conversion input is active, “L” is output from this terminal to enable the input

Pin No.	Pin Name	I/O	Description
36	RE-IN0	I	Dial pulse input of the rotary encoder (RE900) (for VOLUME/BASS/TREBLE/BALANCE/FADER control)
37	RE-IN1	I	
38	DVCC	—	Power supply terminal (+5V) (for D/A converter)
39	DVSS	—	Ground terminal (for D/A converter)
40, 41	NC	O	Not used (open)
42	AVCC	—	Power supply terminal (+5V) (for A/D converter)
43	AVRH	I	Reference voltage (+5V) input terminal (for A/D converter)
44	AVRL	I	Reference voltage (0V) input terminal (for A/D converter)
45	AVSS	—	Ground terminal (for A/D converter)
46	KEYIN0	I	Key input terminal (A/D input) (S901 to S908) OFF, 3, 4, 5, 6, D-BASS, AF, TA keys input
47	KEYIN1	I	Key input terminal (A/D input) (S909 to S920) 2 (XR-1300R), 2 SHUF (XR-C2300R), 1 (XR-1300R), 1 REP (XR-C2300R), ENTER, MODE, DSPL PTY, SEEK +/- (XR-1300R), SEEK/AMS + ►►I ►► - ◄◄ ◄◄ (XR-C2300R), PRST +/- (XR-1300R), PRST DISC +/- (XR-C2300R), TUNER (XR-1300R), SOURCE (XR-C2300R). SOUND. MENU keys input
48	RC-IN0	O	Not used (open) Rotary remote commander key input terminal (A/D input)
49	DSTSEL	I	Destination setting terminal (fixed at "H")
50	NOISE-DET	I	Noise level detection signal input at SEEK mode (A/D input)
51	NC	O	Not used (open)
52	MTP	I	Multi-path detection signal input from the RDS decoder (IC200)
53	VSM	I	FM and AM signal meter voltage detection input from the FM/AM tuner unit (TU100) (A/D input)
54	VCC	—	Power supply terminal (+5V)
55	<u>RAMBU</u>	I	Internal RAM reset detection signal input terminal Input terminal to check that RAM data are not destroyed due to low voltage This checking is made within 100 msec after reset Fixed at "L" in this set
56	POW-SEL	I	Power select input terminal Fixed at "H" in this set
57	NC	O	Not used (open)
58	<u>TESTIN</u>	I	Setting terminal for the test mode "L": test mode, Normally: fixed at "H"
59, 60	NC	O	Not used (open)
61, 62	NC	O	Not used
63	VSS	—	Ground terminal
64	NC	O	Not used (open)
65	MUTE	O	Audio line muting on/off control signal output terminal "H": muting on
66, 67	NC	O	Not used (open)
68	AMPMUTE	O	Muting on/off control signal output to the power amplifier (IC500) "L": muting on
69	<u>FLASH-W</u>	I	Internal flash memory data write mode detection signal input terminal "L": data write mode Not used (fixed at "H" in this set)
70	I2C-SIO	I/O	Two-way data bus with the RDS decoder (IC200)
71	I2C-CKO	O	Bus clock signal output to the RDS decoder (IC200)
72	RC-IN1	O	Not used (open) Rotary remote commander shift key input terminal
73	X1A	O	Sub system clock output terminal (32.768 kHz)
74	X0A	I	Sub system clock input terminal (32.768 kHz)
75	DAVN	I	Data transmit completed detect signal input from the RDS decoder (IC200) "H" active
76	KEYACK	I	Input of acknowledge signal for the key entry Acknowledge signal is input to accept function and eject keys in the power off status On at input of "H"

Pin No.	Pin Name	I/O	Description
77	BU-IN	I	Battery detect signal input from the SONY bus interface (IC800) and battery detect circuit “L” is input at low voltage IC800: Used for the XR-C2300R only
78	$\overline{\text{ILL IN}}$	O	Not used
79	TELATT	I	Telephone muting signal input terminal At input of “H”, the signal is attenuated by -20 dB Not used
80	LCDCE	I	Chip enable signal output to the liquid crystal display driver (IC900) “H” active
81	$\overline{\text{ACC IN}}$	I	Accessory detect signal input terminal “L”: accessory on
82 to 85	NC	O	Not used (open)
86	HSTX	I	Hardware standby input terminal “L”: hardware standby mode Reset signal input in this set
87	MD2	I	Setting terminal for the CPU operational mode (fixed at “L” in this set)
88, 89	MD1, MD0	I	Setting terminal for the CPU operational mode (fixed at “H” in this set)
90	$\overline{\text{RSTX}}$	I	System reset signal input from the reset signal generator (IC2) and reset switch (S2) “L”: reset “L” is input for several 100 msec after power on, then it changes to “H”
91	VSS	—	Ground terminal
92	X0	I	Main system clock input terminal (3.68 MHz)
93	X1	O	Main system clock output terminal (3.68 MHz)
94	VCC	—	Power supply terminal (+5V)
95 to 104	NC	O	Not used (open)
105	$\overline{\text{TAPE IN}}$	I	Tape in detection switch (S903) input terminal “L”: tape in
106	$\overline{\text{FF-REW IN}}$	I	FF/REW detection switch (S902) input terminal “L”: FF/REW mode
107	$\overline{\text{N/R}}$	I	Tape direction switch (S903) input terminal “L”: reverse direction “H”: forward direction
108 to 110	NC	O	Not used (open)
111	CM ON	O	Capstan/reel motor (M901) drive signal output terminal “H”: motor on
112 to 116	NC	O	Not used (open)
117	TAPMUTE	O	Tape muting on/off control signal output terminal “H”: muting on Active at ATA, FF/REW mode Not used (open)
118	AMPON	O	Standby on/off control signal output to the power amplifier (IC500) “L”: standby mode, “H”: amp on
119	VSS	—	Ground terminal
120	PWON	O	Main system power supply on/off control signal output terminal “H”: power on

## SECTION 6 EXPLODED VIEWS

**NOTE:**

- -XX and -X mean standardized parts, so they may have some difference from the original one.
- Color Indication of Appearance Parts  
Example:  
KNOB, BALANCE (WHITE) . . . (RED)  
                                  ↑                  ↑  
                                  Parts Color Cabinet's Color

- Items marked “\*” are not stocked since they are seldom required for routine service. Some delay should be anticipated when ordering these items.
- The mechanical parts with no reference number in the exploded views are not supplied.
- Hardware (# mark) list and accessories and packing materials are given in the last of the electrical parts list.

**(1) GENERAL SECTION**

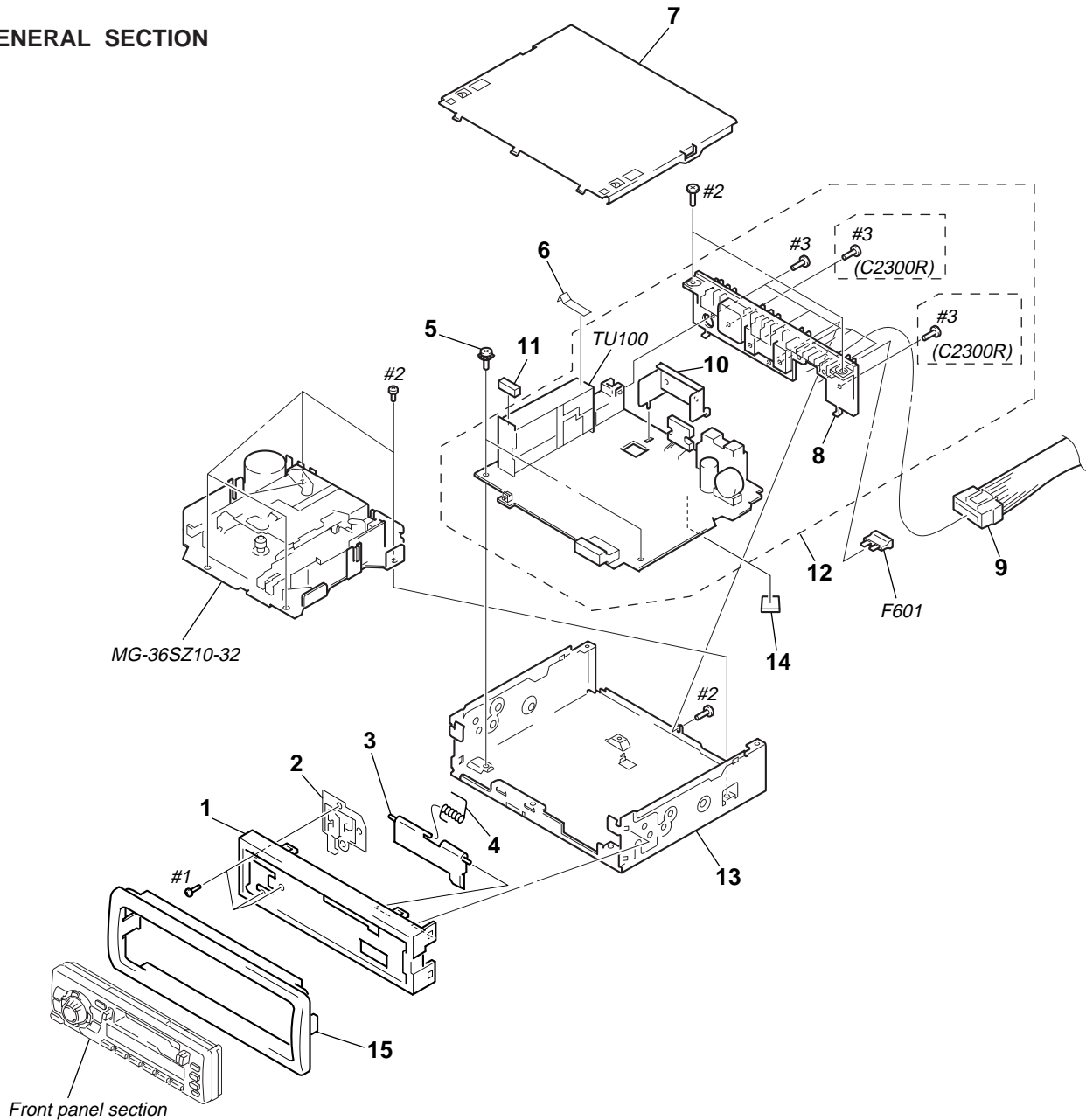

Ref. No.	Part No.	Description	Remark	Ref. No.	Part No.	Description	Remark
1	3-041-580-01	PANEL, SUB		* 10	3-041-578-01	BRACKET (IC)	
2	X-3367-636-1	LOCK ASSY		* 11	3-046-339-01	CUSHION (U)	
3	3-041-581-01	DOOR, CASSETTE		* 12	A-3326-108-A	MAIN BOARD, COMPLETE (C2300R)	
4	3-044-125-01	SPRING, TORSION		* 12	A-3326-391-A	MAIN BOARD, COMPLETE (1300R)	
5	3-376-464-11	SCREW (+PTT 2.6X6), GROUND POINT		* 13	3-041-575-01	CHASSIS	
6	3-029-047-01	PLATE (C), GROUND		14	3-041-576-01	SHEET, INSULATING	
* 7	X-3378-167-1	COVER ASSY		15	3-041-599-01	COLLAR	
* 8	3-041-577-01	HEAT SINK (1300R)		F601	1-532-877-11	FUSE (BLADE TYPE) (AUTO FUSE) (10A)	
* 8	3-041-577-11	HEAT SINK (C2300R)		TU100	1-693-440-12	TUNER UNIT (FM/AM)	
9	1-776-527-31	CORD (WITH CONNECTOR) (ISO) (POWER)					

## (2) FRONT PANEL SECTION

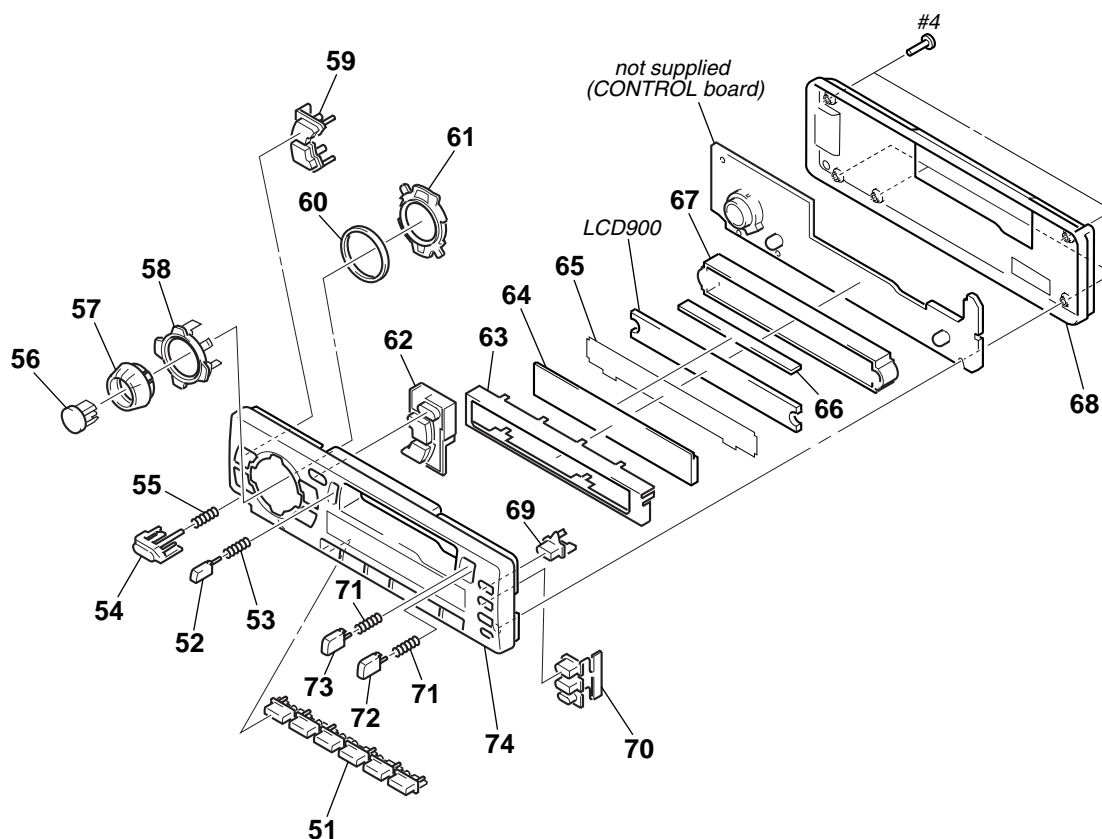

Ref. No.	Part No.	Description	Remark	Ref. No.	Part No.	Description	Remark
51	3-041-597-01	BUTTON (1-6) (1. 2. 3. 4. 5. 6)		62	3-041-594-01	BUTTON (D/M/E) (DSPL. MODE. ENTER)	
52	3-041-582-01	BUTTON (EJECT) (▲)		* 63	3-041-591-01	PLATE (LCD), GROUND	
53	3-029-327-01	SPRING (EJECT)		* 64	3-041-589-01	PLATE, LIGHT GUIDE	
54	3-041-605-01	BUTTON (RELEASE)		* 65	3-041-592-01	ILLUMINATOR	
55	3-932-475-01	SPRING (RELEASE)		66	1-694-696-11	CONDUCTOR BOARD, CONNENTION	
56	3-041-596-01	BUTTON (SOURCE) (C2300R)		* 67	3-041-590-01	HOLDER (LCD)	
56	3-041-602-01	BUTTON (TUNER) (1300R)		68	3-041-588-01	PANEL, FRONT BACK	
57	3-041-604-01	BUTTON (VOL)		69	3-041-598-01	BUTTON (D-BASS)	
58	3-041-603-01	BUTTON (CROSS) (DISC +. DISC -. + ►►► ►►► . - ◄◄◄ ◄◄◄)		70	3-041-601-01	BUTTON (T/A/O) (TA. AF. OFF)	
			(C2300R)	71	3-375-372-01	SPRING (F/R)	
58	3-041-603-11	BUTTON (CROSS) (PRST +. PRST -. SEEK +. SEEK -)		72	3-041-583-01	BUTTON (FF) (►►►)	
			(1300R)	73	3-041-584-01	BUTTON (REW) (◄◄◄)	
59	3-041-595-01	BUTTON (S/M) (MENU. SOUND)		74	X-3378-615-1	PANEL SUB ASSY (C2300R)	
* 60	3-043-247-01	CUSHION (CROSS)		74	X-3378-655-1	PANEL SUB ASSY (1300R)	
61	3-041-593-01	PLATE (RING), LIGHT GUIDE		LCD900	1-803-841-11	DISPLAY PANEL, LIQUID CRYSTAL	

**(3) MECHANISM DECK SECTION  
(MG-36SZ10-32)**

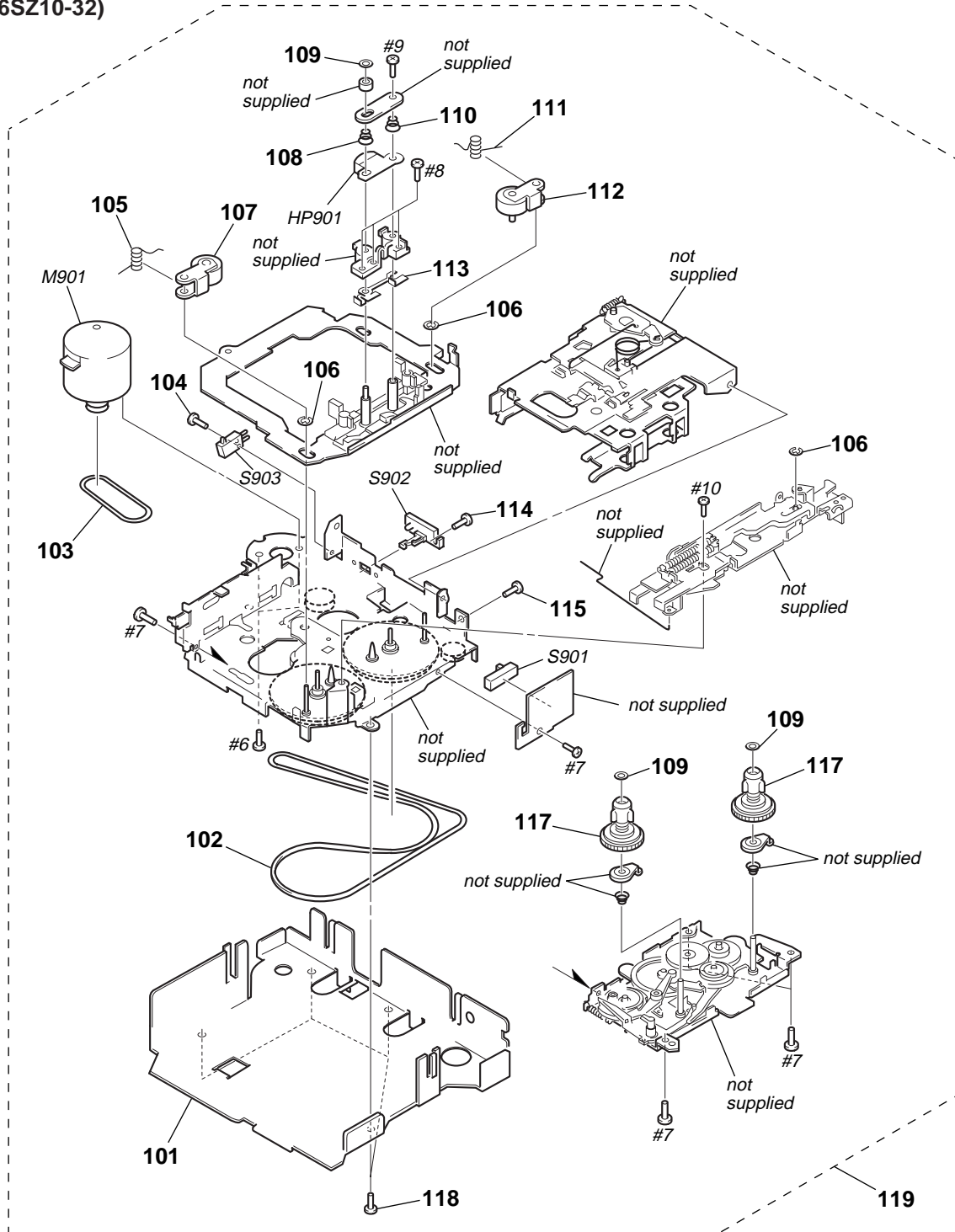

Ref. No.	Part No.	Description	Remark	Ref. No.	Part No.	Description	Remark
* 101	3-041-579-01	BRACKET (MD)		113	3-045-906-01	ADJUSTER SHIM (X)	
102	3-045-943-01	MAIN BELT		114	3-045-952-01	+MACHINE SCREW M1.7X4	
103	3-045-945-01	SUB BELT (C)		115	3-713-786-51	SCREW +P 2X3	
104	3-045-953-01	+MACHINE SCREW M1.7X6		117	3-045-893-01	REEL SPINDLE	
105	3-045-940-01	PINCH ARM SPG (R)		118	3-046-138-01	SCREW (2.6X4) (STYLE) (CZN) +B	
106	3-045-950-01	E-RING (DIA. 2)		119	A-3220-753-A	MECHANISM DECK ASSY (MG-36SZ10-32)	
107	3-045-890-01	PINCH ARM (R)		HP901	1-500-661-11	HEAD (PLAYBACK)	
108	3-045-933-01	ADJUSTER ARM SPG (B)		M901	1-763-507-11	MOTOR (CAPSTAN/REEL)	
109	3-045-949-01	PSW (REEL) B		S901	1-771-928-11	SWITCH (SLIDE) (DIRECTION)	
110	3-045-932-01	ADJUSTER ARM SPG (A)		S902	1-771-926-11	SWITCH (LEAF) (FF/REW)	
111	3-045-939-01	PINCH ARM SPG (F)		S903	1-771-927-11	SWITCH (LEAF) (TAPE DETECT)	
112	3-045-891-01	PINCH ARM (F)					

# SECTION 7 ELECTRICAL PARTS LIST

CONTROL

**NOTE:**

- Due to standardization, replacements in the parts list may be different from the parts specified in the diagrams or the components used on the set.
- -XX and -X mean standardized parts, so they may have some difference from the original one.
- RESISTORS  
All resistors are in ohms.  
METAL: Metal-film resistor.  
METAL OXIDE: Metal oxide-film resistor.  
F: nonflammable
- Abbreviation  
AMBER : Amber illumination type  
GREEN : Green illumination type

- Items marked “\*” are not stocked since they are seldom required for routine service. Some delay should be anticipated when ordering these items.
- SEMICONDUCTORS  
In each case, u:  $\mu$ , for example:  
uA. . :  $\mu$ A. .      uPA. . :  $\mu$ PA. .  
uPB. . :  $\mu$ PB. .    uPC. . :  $\mu$ PC. .  
uPD. . :  $\mu$ PD. .
- CAPACITORS  
uF:  $\mu$ F
- COILS  
uH:  $\mu$ H

When indicating parts by reference number, please include the board.

Ref. No.	Part No.	Description	Remark	Ref. No.	Part No.	Description	Remark
		CONTROL BOARD *****					
	1-694-696-11	CONDUCTOR BOARD, CONNENTION		D910	8-719-976-89	DIODE UDZ-TE-17-5.1B	
*	3-041-589-01	PLATE, LIGHT GUIDE				< IC >	
*	3-041-590-01	HOLDER (LCD)		IC900	8-759-366-34	IC LC75824E	
*	3-041-591-01	PLATE (LCD), GROUND				< LIQUID CRYSTAL DISPLAY >	
*	3-041-592-01	ILLUMINATOR		LCD900	1-803-841-11	DISPLAY PANEL, LIQUID CRYSTAL	
		< CAPACITOR >				< PILOT LAMP >	
C900	1-163-251-11	CERAMIC CHIP 100PF 5% 50V		PL900	1-517-534-11	LAMP, PILOT (LCD BACK LIGHT) (GREEN)	
C901	1-163-037-11	CERAMIC CHIP 0.022uF 10% 25V		PL900	1-517-535-11	LAMP, PILOT (LCD BACK LIGHT) (AMBER)	
C902	1-164-004-11	CERAMIC CHIP 0.1uF 10% 25V		PL901	1-517-534-11	LAMP, PILOT (LCD BACK LIGHT) (GREEN)	
C903	1-164-004-11	CERAMIC CHIP 0.1uF 10% 25V		PL901	1-517-535-11	LAMP, PILOT (LCD BACK LIGHT) (AMBER)	
C904	1-107-823-11	CERAMIC CHIP 0.47uF 10% 16V				< RESISTOR >	
		< CONNECTOR >		R903	1-216-043-00	RES, CHIP 560 5% 1/10W (GREEN)	
CN901	1-794-312-11	PIN CONNECTOR 12P		R903	1-216-045-00	RES, CHIP 680 5% 1/10W (AMBER)	
		< DIODE >		R904	1-216-043-00	RES, CHIP 560 5% 1/10W (GREEN)	
D900	8-719-056-82	DIODE UDZ-TE-17-6.2B		R904	1-216-045-00	RES, CHIP 680 5% 1/10W (AMBER)	
D901	8-719-056-82	DIODE UDZ-TE-17-6.2B		R906	1-216-049-11	RES, CHIP 1K 5% 1/10W	
D902	8-719-056-82	DIODE UDZ-TE-17-6.2B		R907	1-216-049-11	RES, CHIP 1K 5% 1/10W	
D903	8-719-033-13	LED CL-170Y-CD-T (ILLUMINATION) (AMBER)		R908	1-216-049-11	RES, CHIP 1K 5% 1/10W	
D903	8-719-033-14	LED CL-170PG-CD-T (ILLUMINATION) (GREEN)		R909	1-216-045-00	METAL CHIP 680 5% 1/10W	
D904	8-719-033-13	LED CL-170Y-CD-T (1300R: TUNER/C2300R: SOURCE) (AMBER)		R910	1-216-186-00	RES, CHIP 330 5% 1/8W	
D904	8-719-033-14	LED CL-170PG-CD-T (1300R: TUNER/C2300R: SOURCE) (GREEN)		R911	1-216-051-00	METAL CHIP 1.2K 5% 1/10W	
D905	8-719-033-13	LED CL-170Y-CD-T (1300R: TUNER/C2300R: SOURCE) (AMBER)		R912	1-216-647-11	METAL CHIP 680 0.5% 1/10W	
D905	8-719-033-14	LED CL-170PG-CD-T (1300R: TUNER/C2300R: SOURCE) (GREEN)		R913	1-216-647-11	METAL CHIP 680 0.5% 1/10W	
D906	8-719-033-13	LED CL-170Y-CD-T (ILLUMINATION) (AMBER)		R914	1-216-647-11	METAL CHIP 680 0.5% 1/10W	
D906	8-719-033-14	LED CL-170PG-CD-T (ILLUMINATION) (GREEN)		R915	1-208-437-61	RES, CHIP 1K 2% 1/10W	
D907	8-719-033-13	LED CL-170Y-CD-T (ILLUMINATION) (AMBER)		R916	1-208-441-61	RES, CHIP 1.5K 2% 1/10W	
D907	8-719-033-14	LED CL-170PG-CD-T (ILLUMINATION) (GREEN)		R917	1-208-441-61	RES, CHIP 1.5K 2% 1/10W	
D908	8-719-033-13	LED CL-170Y-CD-T (ILLUMINATION) (AMBER)		R918	1-216-659-11	METAL CHIP 2.2K 0.5% 1/10W	
D908	8-719-033-14	LED CL-170PG-CD-T (ILLUMINATION) (GREEN)		R919	1-216-647-11	METAL CHIP 680 0.5% 1/10W	
				R920	1-216-647-11	METAL CHIP 680 0.5% 1/10W	
				R921	1-216-647-11	METAL CHIP 680 0.5% 1/10W	
				R922	1-208-437-61	RES, CHIP 1K 2% 1/10W	
				R923	1-208-441-61	RES, CHIP 1.5K 2% 1/10W	
				R924	1-208-441-61	RES, CHIP 1.5K 2% 1/10W	
				R925	1-216-659-11	METAL CHIP 2.2K 0.5% 1/10W	

**CONTROL**

**MAIN**

Ref. No.	Part No.	Description	Remark
R926	1-208-449-61	RES, CHIP	3.3K 2% 1/10W
R927	1-208-453-61	RES, CHIP	4.7K 2% 1/10W
R928	1-216-671-11	METAL CHIP	6.8K 0.5% 1/10W
R929	1-208-462-61	RES, CHIP	10K 2% 1/10W
R930	1-216-051-00	METAL CHIP	1.2K 5% 1/10W
R931	1-216-051-00	METAL CHIP	1.2K 5% 1/10W
R932	1-216-043-00	RES, CHIP	560 5% 1/10W (GREEN)
R932	1-216-045-00	RES, CHIP	680 5% 1/10W (AMBER)
R933	1-216-043-00	RES, CHIP	560 5% 1/10W (GREEN)
R933	1-216-045-00	RES, CHIP	680 5% 1/10W (AMBER)
R934	1-216-043-00	RES, CHIP	560 5% 1/10W (GREEN)
R934	1-216-045-00	RES, CHIP	680 5% 1/10W (AMBER)
R935	1-216-043-00	RES, CHIP	560 5% 1/10W (GREEN)
R935	1-216-045-00	RES, CHIP	680 5% 1/10W (AMBER)
R936	1-216-043-00	RES, CHIP	560 5% 1/10W (GREEN)
R936	1-216-045-00	RES, CHIP	680 5% 1/10W (AMBER)
R937	1-216-043-00	RES, CHIP	560 5% 1/10W (GREEN)
R937	1-216-045-00	RES, CHIP	680 5% 1/10W (AMBER)
R938	1-216-047-00	RES, CHIP	820 5% 1/10W (GREEN)
R938	1-216-049-11	RES, CHIP	1K 5% 1/10W (AMBER)
R939	1-216-047-00	RES, CHIP	820 5% 1/10W (GREEN)
R939	1-216-049-11	RES, CHIP	1K 5% 1/10W (AMBER)
< SWITCH >			
S900	1-475-014-11	ENCODER, ROTARY (VOLUME/BASS/TREBLE/BALANCE/FADER CONTROL)	
S901	1-771-882-21	SWITCH, TACTILE (WITH LED) (OFF) (AMBER)	
S901	1-771-609-11	SWITCH, TACT (WITH LED) (OFF) (GREEN)	
S902	1-771-882-21	SWITCH, TACTILE (WITH LED) (3) (AMBER)	
S902	1-771-609-11	SWITCH, TACT (WITH LED) (3) (GREEN)	
S903	1-771-882-21	SWITCH, TACTILE (WITH LED) (4) (AMBER)	
S903	1-771-609-11	SWITCH, TACT (WITH LED) (4) (GREEN)	
S904	1-771-882-21	SWITCH, TACTILE (WITH LED) (5) (AMBER)	
S904	1-771-609-11	SWITCH, TACT (WITH LED) (5) (GREEN)	
S905	1-771-882-21	SWITCH, TACTILE (WITH LED) (6) (AMBER)	
S905	1-771-609-11	SWITCH, TACT (WITH LED) (6) (GREEN)	
S906	1-762-737-21	SWITCH, KEY BOARD (LED) (D-BASS)	
S907	1-771-882-21	SWITCH, TACTILE (WITH LED) (AF) (AMBER)	
S907	1-771-609-11	SWITCH, TACT (WITH LED) (AF) (GREEN)	
S908	1-762-617-21	SWITCH, KEY BOARD (WITH LED) (TA) (AMBER)	
S908	1-762-619-21	SWITCH, KEY BOARD (WITH LED) (TA) (GREEN)	

Ref. No.	Part No.	Description	Remark
S909	1-771-882-21	SWITCH, TACTILE (WITH LED) (1300R: 2/C2300R: 2 SHUF) (AMBER)	
S909	1-771-609-11	SWITCH, TACT (WITH LED) (1300R:2/C2300R:2 SHUF) (GREEN)	
S910	1-771-882-21	SWITCH, TACTILE (WITH LED) (1300R: 1/C2300R: 1 REP) (AMBER)	
S910	1-771-609-11	SWITCH, TACT (WITH LED) (1300R:1/C2300R REP) (GREEN)	
S911	1-762-617-21	SWITCH, KEY BOARD (WITH LED) (ENTER) (AMBER)	
S911	1-762-619-21	SWITCH, KEY BOARD (WITH LED) (ENTER) (GREEN)	
S912	1-762-617-21	SWITCH, KEY BOARD (WITH LED) (MODE) (AMBER)	
S912	1-762-619-21	SWITCH, KEY BOARD (WITH LED) (MODE) (GREEN)	
S913	1-762-617-21	SWITCH, KEY BOARD (WITH LED) (DSPL, PTY) (AMBER)	
S913	1-762-619-21	SWITCH, KEY BOARD (WITH LED) (DSPL, PTY) (GREEN)	
S914	1-771-027-21	SWITCH, KEYBOARD (WITH LED) (1300R: SEEK +/C2300R: + ►►►►, SEEK/AMS)	
S915	1-771-027-21	SWITCH, KEYBOARD (WITH LED) (1300R: PRST -/C2300R: DISC -, PRST -)	
S916	1-771-884-21	SWITCH, TACTILE (WITH LED) (1300R: TUNER/C2300R: SOURCE)	
S917	1-771-027-21	SWITCH, KEYBOARD (WITH LED) (1300R: PRST +/C2300R: DISC +, PRST +)	
S918	1-771-027-21	SWITCH, KEYBOARD (WITH LED) (1300R: SEEK -/C2300R: - ◄◄◄◄, SEEK/AMS)	
S919	1-762-617-21	SWITCH, KEY BOARD (WITH LED) (SOUND) (AMBER)	
S919	1-762-619-21	SWITCH, KEY BOARD (WITH LED) (SOUND) (GREEN)	
S920	1-762-617-21	SWITCH, KEY BOARD (WITH LED) (MENU) (AMBER)	
S920	1-762-619-21	SWITCH, KEY BOARD (WITH LED) (MENU) (GREEN)	
*****			
*	A-3326-108-A	MAIN BOARD, COMPLETE (C2300R)	
*	A-3326-391-A	MAIN BOARD, COMPLETE (1300R)	
*****			
*	3-041-577-01	HEAT SINK (1300R)	
*	3-041-577-11	HEAT SINK (C2300R)	
*	3-041-578-01	BRACKET (IC)	
	7-685-794-09	SCREW +PTT 2.6X10 (S)	
< CAPACITOR >			
C1	1-163-021-11	CERAMIC CHIP	0.01uF 10% 50V
C2	1-124-584-00	ELECT	100uF 20% 10V
C3	1-164-004-11	CERAMIC CHIP	0.1uF 10% 25V
C4	1-164-004-11	CERAMIC CHIP	0.1uF 10% 25V
C5	1-164-004-11	CERAMIC CHIP	0.1uF 10% 25V
C6	1-164-004-11	CERAMIC CHIP	0.1uF 10% 25V
C7	1-164-004-11	CERAMIC CHIP	0.1uF 10% 25V
C8	1-163-235-11	CERAMIC CHIP	22PF 5% 50V
C9	1-163-102-00	CERAMIC CHIP	24PF 5% 50V
C10	1-163-021-11	CERAMIC CHIP	0.01uF 10% 50V
C11	1-124-584-00	ELECT	100uF 20% 10V
C12	1-163-021-11	CERAMIC CHIP	0.01uF 10% 50V
C100	1-163-235-11	CERAMIC CHIP	22PF 5% 50V

Ref. No.	Part No.	Description	Remark			Ref. No.	Part No.	Description	Remark		
C101	1-163-133-00	CERAMIC CHIP	470PF	5%	50V	C220	1-104-760-11	CERAMIC CHIP	0.047uF	10%	50V
C102	1-126-157-11	ELECT	10uF	20%	16V	C221	1-164-004-11	CERAMIC CHIP	0.1uF	10%	25V
C103	1-163-009-11	CERAMIC CHIP	0.001uF	10%	50V	C222	1-126-154-11	ELECT	47uF	20%	6.3V
C104	1-126-157-11	ELECT	10uF	20%	16V	C300	1-163-009-11	CERAMIC CHIP	0.001uF	10%	50V
C105	1-163-021-11	CERAMIC CHIP	0.01uF	10%	50V	C301	1-163-009-11	CERAMIC CHIP	0.001uF	10%	50V
C106	1-126-157-11	ELECT	10uF	20%	16V	C302	1-163-251-11	CERAMIC CHIP	100PF	5%	50V
C107	1-163-021-11	CERAMIC CHIP	0.01uF	10%	50V	C303	1-163-251-11	CERAMIC CHIP	100PF	5%	50V
C108	1-163-009-11	CERAMIC CHIP	0.001uF	10%	50V	C304	1-124-584-00	ELECT	100uF	20%	10V
C109	1-163-005-11	CERAMIC CHIP	470PF	10%	50V	C305	1-124-584-00	ELECT	100uF	20%	10V
C130	1-163-085-00	CERAMIC CHIP	2PF	0.25PF	50V	C306	1-163-021-11	CERAMIC CHIP	0.01uF	10%	50V
C131	1-163-224-11	CERAMIC CHIP	7PF	0.5PF	50V	C307	1-163-021-11	CERAMIC CHIP	0.01uF	10%	50V
C132	1-163-224-11	CERAMIC CHIP	7PF	0.5PF	50V	C308	1-163-133-00	CERAMIC CHIP	470PF	5%	50V
C133	1-164-004-11	CERAMIC CHIP	0.1uF	10%	25V	C309	1-124-229-00	ELECT	33uF	20%	10V
C134	1-163-251-11	CERAMIC CHIP	100PF	5%	50V	C310	1-126-157-11	ELECT	10uF	20%	16V
C135	1-163-021-11	CERAMIC CHIP	0.01uF	10%	50V	C311	1-163-021-11	CERAMIC CHIP	0.01uF	10%	50V
C136	1-163-020-00	CERAMIC CHIP	0.0082uF	10%	50V	C400	1-104-942-11	ELECT	1uF	20%	50V
C137	1-104-760-11	CERAMIC CHIP	0.047uF	10%	50V	C401	1-104-942-11	ELECT	1uF	20%	50V
C138	1-109-982-11	CERAMIC CHIP	1uF	10%	10V	C402	1-109-982-11	CERAMIC CHIP	1uF	10%	10V
C139	1-104-760-11	CERAMIC CHIP	0.047uF	10%	50V	C403	1-109-982-11	CERAMIC CHIP	1uF	10%	10V
C140	1-163-021-11	CERAMIC CHIP	0.01uF	10%	50V	C404	1-164-182-11	CERAMIC CHIP	0.0033uF	10%	50V
C141	1-126-157-11	ELECT	10uF	20%	16V	C405	1-164-182-11	CERAMIC CHIP	0.0033uF	10%	50V
C142	1-126-157-11	ELECT	10uF	20%	16V	C406	1-163-989-11	CERAMIC CHIP	0.033uF	10%	25V
C143	1-124-234-00	ELECT	22uF	20%	16V	C407	1-163-989-11	CERAMIC CHIP	0.033uF	10%	25V
C144	1-163-251-11	CERAMIC CHIP	100PF	5%	50V	C408	1-126-157-11	ELECT	10uF	20%	16V
C145	1-163-251-11	CERAMIC CHIP	100PF	5%	50V	C409	1-126-157-11	ELECT	10uF	20%	16V
C146	1-163-021-11	CERAMIC CHIP	0.01uF	10%	50V	C410	1-164-489-11	CERAMIC CHIP	0.22uF	10%	16V
C147	1-163-009-11	CERAMIC CHIP	0.001uF	10%	50V	C411	1-164-489-11	CERAMIC CHIP	0.22uF	10%	16V
C151	1-104-760-11	CERAMIC CHIP	0.047uF	10%	50V	C412	1-164-492-11	CERAMIC CHIP	0.15uF	10%	16V
C152	1-164-489-11	CERAMIC CHIP	0.22uF	10%	16V	C413	1-164-492-11	CERAMIC CHIP	0.15uF	10%	16V
C153	1-163-037-11	CERAMIC CHIP	0.022uF	10%	25V	C414	1-126-157-11	ELECT	10uF	20%	16V
C160	1-163-020-00	CERAMIC CHIP	0.0082uF	10%	50V	C415	1-126-157-11	ELECT	10uF	20%	16V
C161	1-163-020-00	CERAMIC CHIP	0.0082uF	10%	50V	C416	1-126-572-11	ELECT	4.7uF	20%	35V
C162	1-124-257-00	ELECT	2.2uF	20%	50V	C417	1-126-572-11	ELECT	4.7uF	20%	35V
C163	1-124-257-00	ELECT	2.2uF	20%	50V	C418	1-126-572-11	ELECT	4.7uF	20%	35V
C164	1-124-257-00	ELECT	2.2uF	20%	50V	C419	1-126-572-11	ELECT	4.7uF	20%	35V
C165	1-124-257-00	ELECT	2.2uF	20%	50V	C420	1-163-009-11	CERAMIC CHIP	0.001uF	10%	50V
C166	1-126-163-11	ELECT	4.7uF	20%	50V	C421	1-163-009-11	CERAMIC CHIP	0.001uF	10%	50V
C200	1-164-004-11	CERAMIC CHIP	0.1uF	10%	25V	C422	1-163-009-11	CERAMIC CHIP	0.001uF	10%	50V
C201	1-163-133-00	CERAMIC CHIP	470PF	5%	50V	C423	1-163-009-11	CERAMIC CHIP	0.001uF	10%	50V
C202	1-163-229-11	CERAMIC CHIP	12PF	5%	50V	C424	1-124-464-11	ELECT	0.22uF	20%	50V
C203	1-163-229-11	CERAMIC CHIP	12PF	5%	50V	C425	1-124-464-11	ELECT	0.22uF	20%	50V
C204	1-164-004-11	CERAMIC CHIP	0.1uF	10%	25V	C426	1-124-464-11	ELECT	0.22uF	20%	50V
C205	1-163-009-11	CERAMIC CHIP	0.001uF	10%	50V	C427	1-124-464-11	ELECT	0.22uF	20%	50V
C206	1-164-161-11	CERAMIC CHIP	0.0022uF	10%	100V	C428	1-163-251-11	CERAMIC CHIP	100PF	5%	50V
C207	1-163-135-00	CERAMIC CHIP	560PF	5%	50V	C429	1-163-251-11	CERAMIC CHIP	100PF	5%	50V
C208	1-115-565-11	CERAMIC CHIP	2.2uF	10%	10V						(C2300R)
C209	1-163-263-11	CERAMIC CHIP	330PF	5%	50V						(C2300R)
C210	1-163-021-11	CERAMIC CHIP	0.01uF	10%	50V	C430	1-124-234-00	ELECT	22uF	20%	16V
C211	1-124-234-00	ELECT	22uF	20%	16V	C431	1-124-584-00	ELECT	100uF	20%	10V
C212	1-163-009-11	CERAMIC CHIP	0.001uF	10%	50V	C434	1-107-823-11	CERAMIC CHIP	0.47uF	10%	16V
C213	1-163-009-11	CERAMIC CHIP	0.001uF	10%	50V						(C2300R)
C214	1-163-009-11	CERAMIC CHIP	0.001uF	10%	50V	C435	1-107-823-11	CERAMIC CHIP	0.47uF	10%	16V
C215	1-164-004-11	CERAMIC CHIP	0.1uF	10%	25V						(C2300R)
C216	1-164-004-11	CERAMIC CHIP	0.1uF	10%	25V	C436	1-163-251-11	CERAMIC CHIP	100PF	5%	50V
C217	1-163-133-00	CERAMIC CHIP	470PF	5%	50V						(C2300R)
C218	1-163-227-11	CERAMIC CHIP	10PF	0.5PF	50V	C437	1-163-251-11	CERAMIC CHIP	100PF	5%	50V
C219	1-107-823-11	CERAMIC CHIP	0.47uF	10%	16V						(C2300R)
						C508	1-124-589-11	ELECT	47uF	20%	16V
						C509	1-104-942-11	ELECT	1uF	20%	50V

# MAIN

Ref. No.	Part No.	Description	Remark	Ref. No.	Part No.	Description	Remark
C510	1-104-942-11	ELECT	1uF 20% 50V	D501	8-719-200-82	DIODE 11ES2-TA1B	
C511	1-109-982-11	CERAMIC CHIP	1uF 10% 10V	D502	8-719-200-82	DIODE 11ES2-TA1B	
C512	1-104-760-11	CERAMIC CHIP	0.047uF 10% 50V	D503	8-719-200-82	DIODE 11ES2-TA1B	
C513	1-163-021-11	CERAMIC CHIP	0.01uF 10% 50V	D504	8-719-200-82	DIODE 11ES2-TA1B	
C601	1-124-589-11	ELECT	47uF 20% 16V	D505	8-719-200-82	DIODE 11ES2-TA1B	
C603	1-163-021-11	CERAMIC CHIP	0.01uF 10% 50V	D506	8-719-200-82	DIODE 11ES2-TA1B	
C605	1-104-942-11	ELECT	1uF 20% 50V	D507	8-719-200-82	DIODE 11ES2-TA1B	
C607	1-164-505-11	CERAMIC CHIP	2.2uF 16V	D600	8-719-991-33	DIODE 1SS133T-77	
C608	1-109-982-11	CERAMIC CHIP	1uF 10% 10V	D602	8-719-110-03	DIODE MTZJ-T-77-7.5C (C1300R)	
C609	1-104-760-11	CERAMIC CHIP	0.047uF 10% 50V	D603	8-719-109-97	DIODE MTZJ-T-77-6.8B	
C610	1-104-760-11	CERAMIC CHIP	0.047uF 10% 50V	D605	8-719-922-03	DIODE MTZJ-T-77-18C	
C700	1-126-936-11	ELECT	3300uF 20% 16V	D606	8-719-109-93	DIODE MTZJ-T-77-6.2B	
C701	1-164-004-11	CERAMIC CHIP	0.1uF 10% 25V	D607	8-719-109-93	DIODE MTZJ-T-77-6.2B	
C707	1-163-251-11	CERAMIC CHIP	100PF 5% 50V	D608	8-719-109-93	DIODE MTZJ-T-77-6.2B	
C708	1-163-037-11	CERAMIC CHIP	0.022uF 10% 25V	D609	8-719-109-93	DIODE MTZJ-T-77-6.2B	
C709	1-126-157-11	ELECT	10uF 20% 16V	D610	8-719-109-93	DIODE MTZJ-T-77-6.2B	
C710	1-124-584-00	ELECT	100uF 20% 10V	D611	8-719-109-93	DIODE MTZJ-T-77-6.2B	
C711	1-163-037-11	CERAMIC CHIP	0.022uF 10% 25V	D612	8-719-109-93	DIODE MTZJ-T-77-6.2B	
C712	1-126-157-11	ELECT	10uF 20% 16V	D613	8-719-109-93	DIODE MTZJ-T-77-6.2B	
C713	1-124-229-00	ELECT	33uF 20% 10V	D614	8-719-988-61	DIODE 1SS355TE-17	
C714	1-125-701-11	DOUBLE LAYER	0.047F 5.5V	D615	8-719-991-33	DIODE 1SS133T-77	
C715	1-128-499-11	ELECT	220uF 20% 16V	D616	8-719-929-15	DIODE HZS9.1NB2	
C716	1-126-157-11	ELECT	10uF 20% 16V	D617	8-719-988-61	DIODE 1SS355TE-17	
C717	1-163-009-11	CERAMIC CHIP	0.001uF 10% 50V	D700	8-719-049-38	DIODE 1N5404TU	
C718	1-164-004-11	CERAMIC CHIP	0.1uF 10% 25V	D702	8-719-200-82	DIODE 11ES2-TA1B	
C719	1-126-157-11	ELECT	10uF 20% 16V	D703	8-719-200-82	DIODE 11ES2-TA1B	
C720	1-163-037-11	CERAMIC CHIP	0.022uF 10% 25V	D704	8-719-991-33	DIODE 1SS133T-77	
C721	1-164-004-11	CERAMIC CHIP	0.1uF 10% 25V	D705	8-719-048-54	DIODE MTZJ-T-77-10A	
C722	1-119-774-11	ELECT	100uF 20% 16V	D706	8-719-991-33	DIODE 1SS133T-77	
C800	1-163-021-11	CERAMIC CHIP	0.01uF 10% 50V	D707	8-719-935-40	DIODE HZS6B2LTD	
C801	1-164-004-11	CERAMIC CHIP	0.1uF 10% 25V	D708	8-719-200-82	DIODE 11ES2-TA1B	
C802	1-164-004-11	CERAMIC CHIP	0.1uF 10% 25V	D709	8-719-200-82	DIODE 11ES2-TA1B	
C803	1-126-940-11	ELECT	330uF 20% 25V	D710	8-719-109-89	DIODE MTZJ-T-77-5.6B	
		< CONNECTOR >		D713	8-719-109-93	DIODE MTZJ-T-77-6.2B	
CN100	1-764-808-21	JACK (ANT) (FM/AM ANTENNA)		D800	8-719-109-97	DIODE MTZJ-T-77-6.8B (C2300R)	
* CN300	1-564-705-11	PIN, CONNECTOR (PC BOARD) 3P		D801	8-719-109-93	DIODE MTZJ-T-77-6.2B (C2300R)	
* CN350	1-573-486-11	PIN, CONNECTOR (PC BOARD) 8P		D802	8-719-922-03	DIODE MTZJ-T-77-18C (C2300R)	
CN400	1-774-699-12	JACK, PIN 4P (BUS AUDIO IN, AUDIO OUT)	(C2300R)	D803	8-719-991-33	DIODE 1SS133T-77 (C2300R)	
CN600	1-764-423-11	PIN, CONNECTOR 12P		D804	8-719-922-03	DIODE MTZJ-T-77-18C (C2300R)	
CN700	1-774-701-11	PIN, CONNECTOR 16P (POWER)				< IC >	
CN800	1-580-907-31	PLUG, CONNECTOR (BUS CONTROL IN)	(C2300R)	IC1	8-759-654-48	IC MB90574PMT-G-268-BND	
		< DIODE >		IC2	8-759-574-61	IC XC61AN4302MR	
D1	8-719-066-10	DIODE 1PS181-115		IC130	8-759-586-59	IC TB2118F-EL-S	
D102	8-719-991-33	DIODE 1SS133T-77		IC200	8-759-650-68	IC SAA6588T/V2-118	
D103	8-719-991-33	DIODE 1SS133T-77		IC201	8-759-331-72	IC NJM4558E-D (TE2)	
D160	8-719-109-72	DIODE MTZJ-T-77-3.9B		IC300	8-759-924-46	IC BA4560F-T1	
D200	8-719-109-85	DIODE MTZJ-T-77-5.1B		IC400	8-759-487-82	IC LC75374E	
D201	8-719-991-33	DIODE 1SS133T-77		IC500	8-759-486-44	IC TDA7386	
D202	8-719-991-33	DIODE 1SS133T-77		IC800	8-759-096-16	IC MM1175XFF (C2300R)	
D203	8-719-109-72	DIODE MTZJ-T-77-3.9B				< COIL >	
D300	8-719-991-33	DIODE 1SS133T-77		L1	1-410-509-11	INDUCTOR 10uH	
D400	8-719-109-72	DIODE MTZJ-T-77-3.9B		L102	1-410-509-11	INDUCTOR 10uH	
D500	8-719-200-82	DIODE 11ES2-TA1B		L103	1-410-750-41	INDUCTOR 0.47uH	
				L700	1-419-476-11	COIL, CHOKER	

Ref. No.	Part No.	Description	Remark	Ref. No.	Part No.	Description	Remark	
< TRANSISTOR >				R20	1-216-097-00	RES, CHIP 100K 5%	1/10W	
Q1	8-729-043-32	TRANSISTOR	PDTA114EK-115	R21	1-216-097-00	RES, CHIP 100K 5%	1/10W	
Q2	8-729-043-32	TRANSISTOR	PDTA114EK-115	R22	1-216-097-00	RES, CHIP 100K 5%	1/10W	
Q101	8-729-043-27	TRANSISTOR	PDTC114EK-115	R25	1-216-097-00	RES, CHIP 100K 5%	1/10W	
Q102	8-729-901-46	TRANSISTOR	DTA114YK-T146	R100	1-216-049-11	RES, CHIP 1K 5%	1/10W	
Q103	8-729-043-28	TRANSISTOR	PDTC124EK-115	R101	1-216-029-00	METAL CHIP 150 5%	1/10W	
Q104	8-729-049-85	TRANSISTOR	2PB710AR-115	R102	1-216-073-00	METAL CHIP 10K 5%	1/10W	
Q105	8-729-904-63	TRANSISTOR	DTB123YK-T-146	R103	1-216-073-00	METAL CHIP 10K 5%	1/10W	
Q106	8-729-049-86	TRANSISTOR	2PD602AR-115	R104	1-216-073-00	METAL CHIP 10K 5%	1/10W	
Q160	8-729-920-21	TRANSISTOR	DTC314TK-T-146	R105	1-216-065-00	RES, CHIP 4.7K 5%	1/10W	
Q161	8-729-920-21	TRANSISTOR	DTC314TK-T-146	R106	1-216-049-11	RES, CHIP 1K 5%	1/10W	
Q162	8-729-043-32	TRANSISTOR	PDTA114EK-115	R109	1-216-049-11	RES, CHIP 1K 5%	1/10W	
Q163	8-729-043-27	TRANSISTOR	PDTC114EK-115	R110	1-216-049-11	RES, CHIP 1K 5%	1/10W	
Q200	8-729-422-33	TRANSISTOR	2PD601AR-115	R111	1-216-049-11	RES,CHIP 1K 5%	1/10W	
Q201	8-729-043-27	TRANSISTOR	PDTC114EK-115	R134	1-216-073-00	METAL CHIP 10K 5%	1/10W	
Q400	8-729-920-21	TRANSISTOR	DTC314TK-T-146	R135	1-216-067-00	METAL CHIP 5.6K 5%	1/10W	
Q401	8-729-920-21	TRANSISTOR	DTC314TK-T-146	R136	1-216-061-00	METAL CHIP 3.3K 5%	1/10W	
Q402	8-729-920-21	TRANSISTOR	DTC314TK-T-146	R137	1-216-067-00	METAL CHIP 5.6K 5%	1/10W	
Q403	8-729-920-21	TRANSISTOR	DTC314TK-T-146	R139	1-216-025-00	RES, CHIP 100 5%	1/10W	
Q600	8-729-043-32	TRANSISTOR	PDTA114EK-115	R140	1-216-025-00	RES, CHIP 100 5%	1/10W	
Q601	8-729-021-94	FET	2SK1657-T1B	R150	1-216-065-00	RES, CHIP 4.7K 5%	1/10W	
Q602	8-729-043-29	TRANSISTOR	PDTC144EK-115 (1300R)	R151	1-216-073-00	METAL CHIP 10K 5%	1/10W	
Q603	8-729-422-33	TRANSISTOR	2PD601AR-115 (1300R)	R160	1-216-085-00	METAL CHIP 33K 5%	1/10W	
Q604	8-729-043-27	TRANSISTOR	PDTC114EK-115	R161	1-216-085-00	METAL CHIP 33K 5%	1/10W	
Q605	8-729-422-33	TRANSISTOR	2PD601AR-115	R162	1-216-077-00	RES, CHIP 15K 5%	1/10W	
Q700	8-729-921-48	TRANSISTOR	2SD1760F5-TRPQR	R163	1-216-077-00	RES, CHIP 15K 5%	1/10W	
Q701	8-729-216-22	TRANSISTOR	2PB709AR-115	R164	1-216-045-00	METAL CHIP 680 5%	1/10W	
Q702	8-729-043-30	TRANSISTOR	PDTC114TK-115	R165	1-216-051-00	METAL CHIP 1.2K 5%	1/10W	
Q703	8-729-205-96	TRANSISTOR	2SC3668-OY-TPE2	R166	1-216-051-00	METAL CHIP 1.2K 5%	1/10W	
Q704	8-729-205-95	TRANSISTOR	2SA1428-OY-TPF2	R200	1-216-113-00	METAL CHIP 470K 5%	1/10W	
Q705	8-729-216-22	TRANSISTOR	2PB709AR-115	R201	1-216-049-11	RES, CHIP 1K 5%	1/10W	
Q706	8-729-043-28	TRANSISTOR	PDTC124EK-115	R202	1-216-061-00	METAL CHIP 3.3K 5%	1/10W	
Q707	8-729-205-95	TRANSISTOR	2SA1428-OY-TPF2	R203	1-216-001-00	METAL CHIP 10 5%	1/10W	
Q708	8-729-043-27	TRANSISTOR	PDTC114EK-115	R204	1-216-041-00	METAL CHIP 470 5%	1/10W	
Q709	8-729-205-95	TRANSISTOR	2SA1428-OY-TPF2	R205	1-216-037-00	METAL CHIP 330 5%	1/10W	
Q710	8-729-043-27	TRANSISTOR	PDTC114EK-115	R206	1-216-037-00	METAL CHIP 330 5%	1/10W	
Q711	8-729-205-95	TRANSISTOR	2SA1428-OY-TPF2	R207	1-216-001-00	METAL CHIP 10 5%	1/10W	
Q712	8-729-422-33	TRANSISTOR	2PD601AR-115	R208	1-216-049-11	RES, CHIP 1K 5%	1/10W	
< RESISTOR >				R209	1-216-057-00	METAL CHIP 2.2K 5%	1/10W	
R1	1-216-097-00	RES, CHIP	100K 5%	1/10W	R210	1-216-057-00	METAL CHIP 2.2K 5%	1/10W
R2	1-216-097-00	RES, CHIP	100K 5%	1/10W	R211	1-216-065-00	RES, CHIP 4.7K 5%	1/10W
R3	1-216-097-00	RES, CHIP	100K 5%	1/10W	R212	1-216-097-00	RES, CHIP 100K 5%	1/10W
R4	1-216-057-00	METAL CHIP	2.2K 5%	1/10W	R213	1-216-061-00	METAL CHIP 3.3K 5%	1/10W
R5	1-216-057-00	METAL CHIP	2.2K 5%	1/10W	R214	1-216-065-00	RES, CHIP 4.7K 5%	1/10W
R6	1-216-057-00	METAL CHIP	2.2K 5%	1/10W	R215	1-216-121-00	RES, CHIP 1M 5%	1/10W
R7	1-216-097-00	RES, CHIP	100K 5%	1/10W	R216	1-216-097-00	RES, CHIP 100K 5%	1/10W
R9	1-216-113-00	METAL CHIP	470K 5%	1/10W	R217	1-216-057-00	METAL CHIP 2.2K 5%	1/10W
R11	1-216-097-00	RES, CHIP	100K 5%	1/10W	R300	1-216-089-00	RES, CHIP 47K 5%	1/10W
R12	1-216-097-00	RES, CHIP	100K 5%	1/10W	R301	1-216-089-00	RES, CHIP 47K 5%	1/10W
R13	1-216-057-00	METAL CHIP	2.2K 5%	1/10W	R302	1-216-013-00	METAL CHIP 33 5%	1/10W
R14	1-216-057-00	METAL CHIP	2.2K 5%	1/10W	R303	1-216-013-00	METAL CHIP 33 5%	1/10W
R15	1-216-089-00	RES, CHIP	47K 5%	1/10W	R304	1-216-115-00	METAL CHIP 560K 5%	1/10W
R16	1-216-089-00	RES, CHIP	47K 5%	1/10W	R305	1-216-115-00	METAL CHIP 560K 5%	1/10W
R17	1-216-097-00	RES, CHIP	100K 5%	1/10W	R306	1-216-077-00	RES, CHIP 15K 5%	1/10W
R18	1-216-097-00	RES, CHIP	100K 5%	1/10W	R307	1-216-077-00	RES, CHIP 15K 5%	1/10W
R19	1-216-073-00	METAL CHIP	10K 5%	1/10W	R308	1-216-049-11	RES, CHIP 1K 5%	1/10W
					R309	1-216-049-11	RES, CHIP 1K 5%	1/10W
					R310	1-216-073-00	METAL CHIP 10K 5%	1/10W

**MAIN**

Ref. No.	Part No.	Description	Remark	Ref. No.	Part No.	Description	Remark
R311	1-216-073-00	METAL CHIP	10K 5%	1/10W	R707	1-216-081-00	METAL CHIP 22K 5% 1/10W
R312	1-247-807-31	CARBON	100 5%	1/4W	R708	1-249-421-11	CARBON 2.2K 5% 1/4W
R400	1-216-065-00	RES, CHIP	4.7K 5%	1/10W	R709	1-216-097-00	RES, CHIP 100K 5% 1/10W
R401	1-216-065-00	RES, CHIP	4.7K 5%	1/10W	R710	1-249-385-11	CARBON 2.2 5% 1/6W
R402	1-216-033-00	METAL CHIP	220 5%	1/10W	R711	1-249-385-11	CARBON 2.2 5% 1/6W
R403	1-216-033-00	METAL CHIP	220 5%	1/10W	R712	1-249-385-11	CARBON 2.2 5% 1/6W
R404	1-216-033-00	METAL CHIP	220 5%	1/10W	R713	1-249-385-11	CARBON 2.2 5% 1/6W
R405	1-216-033-00	METAL CHIP	220 5%	1/10W	R714	1-216-073-00	METAL CHIP 10K 5% 1/10W
R406	1-216-065-00	RES, CHIP	4.7K 5%	1/10W	R715	1-216-295-00	SHORT 0
R407	1-216-065-00	RES, CHIP	4.7K 5%	1/10W	R716	1-247-185-11	CARBON 2.7 5% 1/2W
R408	1-216-065-00	RES, CHIP	4.7K 5%	1/10W	R717	1-249-421-11	CARBON 2.2K 5% 1/4W
R409	1-216-065-00	RES, CHIP	4.7K 5%	1/10W	R718	1-247-752-11	CARBON 1K 5% 1/2W (C2300R)
R410	1-216-089-00	RES, CHIP	47K 5%	1/10W	R719	1-216-073-00	METAL CHIP 10K 5% 1/10W
R411	1-216-089-00	RES, CHIP	47K 5%	1/10W	R720	1-216-049-11	RES, CHIP 1K 5% 1/10W
R412	1-216-089-00	RES, CHIP	47K 5%	1/10W	R721	1-216-049-11	RES, CHIP 1K 5% 1/10W
R413	1-216-089-00	RES, CHIP	47K 5%	1/10W	R800	1-216-017-00	RES, CHIP 47 5% 1/10W (C2300R)
R414	1-216-295-00	SHORT	0 (C2300R)		R801	1-216-097-00	RES, CHIP 100K 5% 1/10W (1300R)
R415	1-216-295-00	SHORT	0 (C2300R)		R802	1-216-025-00	RES, CHIP 100 5% 1/10W (C2300R)
R416	1-216-057-00	METAL CHIP	2.2K 5%	1/10W (C2300R)	R803	1-216-073-00	METAL CHIP 10K 5% 1/10W (C2300R)
R417	1-216-057-00	METAL CHIP	2.2K 5%	1/10W (C2300R)	R804	1-216-025-00	RES, CHIP 100 5% 1/10W (C2300R)
R418	1-216-073-00	METAL CHIP	10K 5%	1/10W (C2300R)	< COMPOSITION CIRCUIT BLOCK >		
R419	1-216-073-00	METAL CHIP	10K 5%	1/10W (C2300R)	RN1	1-216-825-11	METAL CHIP 2.2K 5% 1/16W
R420	1-249-393-11	CARBON	10 5%	1/4W	RN800	1-216-845-11	METAL CHIP 100K 5% 1/16W (1300R)
R500	1-216-089-00	RES, CHIP	47K 5%	1/10W	< SWITCH >		
R501	1-216-069-00	METAL CHIP	6.8K 5%	1/10W	S2	1-692-431-21	SWITCH, TACTILE (RESET)
R502	1-216-073-00	METAL CHIP	10K 5%	1/10W	< TUNER >		
R503	1-216-073-00	METAL CHIP	10K 5%	1/10W	TU100	1-693-440-12	TUNER UNIT (FM/AM)
R602	1-216-089-00	RES, CHIP	47K 5%	1/10W (1300R)	< VARIABLE RESISTOR >		
R605	1-216-081-00	METAL CHIP	22K 5%	1/10W	VR100	1-241-768-11	RES, ADJ, CARBON 220K
R606	1-216-081-00	METAL CHIP	22K 5%	1/10W	< VIBRATOR >		
R607	1-216-089-00	RES, CHIP	47K 5%	1/10W (1300R)	X1	1-767-833-21	VIBRATOR, CERAMIC (3.68MHz)
R608	1-216-089-00	RES, CHIP	47K 5%	1/10W (1300R)	X2	1-567-098-41	VIBRATOR, CRYSTAL (32.768kHz)
R609	1-216-097-00	RES, CHIP	100K 5%	1/10W	X100	1-781-246-21	VIBRATOR, CRYSTAL (10.25MHz)
R610	1-216-097-00	RES, CHIP	100K 5%	1/10W	X201	1-579-242-11	VIBRATOR, CRYSTAL (4.332MHz)
R611	1-216-073-00	METAL CHIP	10K 5%	1/10W	*****		
R612	1-216-073-00	METAL CHIP	10K 5%	1/10W	MISCELLANEOUS		
R613	1-216-025-00	RES, CHIP	100 5%	1/10W	*****		
R614	1-216-025-00	RES, CHIP	100 5%	1/10W	9	1-776-527-31	CORD (WITH CONNECTOR) (ISO) (POWER)
R615	1-216-025-00	RES, CHIP	100 5%	1/10W	66	1-694-696-11	CONDUCTOR BOARD, CONNECTION
R616	1-216-025-00	RES, CHIP	100 5%	1/10W	F601	1-532-877-11	FUSE (BLADE TYPE) (AUTO FUSE) (10A)
R617	1-216-025-00	RES, CHIP	100 5%	1/10W	HP901	1-500-661-11	HEAD (PLAYBACK)
R618	1-216-105-00	RES, CHIP	220K 5%	1/10W	LCD900	1-803-841-11	DISPLAY PANEL, LIQUID CRYSTAL
R619	1-216-049-11	RES, CHIP	1K 5%	1/10W	M901	1-763-507-11	MOTOR (CAPSTAN/REEL)
R621	1-216-073-00	METAL CHIP	10K 5%	1/10W	S901	1-771-928-11	SWITCH (SLIDE) (DIRECTION)
R622	1-216-081-00	METAL CHIP	22K 5%	1/10W	S902	1-771-926-11	SWITCH (LEAF) (FF/REW)
R700	1-249-413-11	CARBON	470 5%	1/4W			
R701	1-216-057-00	METAL CHIP	2.2K 5%	1/10W			
R702	1-249-421-11	CARBON	2.2K 5%	1/4W			
R703	1-216-081-00	METAL CHIP	22K 5%	1/10W			
R705	1-249-425-11	CARBON	4.7K 5%	1/4W			
R706	1-216-089-00	RES, CHIP	47K 5%	1/10W			

Ref. No.	Part No.	Description	Remark
S903	1-771-927-11	SWITCH (LEAF) (TAPE DETECT)	
*****			
*****			
HARDWARE LIST			
*****			
#1	7-685-782-09	SCREW +PTT 2X5 (S)	
#2	7-685-792-09	SCREW +PTT 2.6X6 (S)	
#3	7-685-794-09	SCREW +PTT 2.6X10 (S)	
#4	7-685-105-19	TPG +P 2X8, TYPE 2, NON-SLIT	
#6	7-627-553-27	PRECISION SCREW +P 2X2.5 TYPE3	
#7	7-685-101-11	SCREW +PTP 2X3 NON-SLIT	
#8	7-621-255-35	SCREW +P 2X5	
#9	7-621-255-25	SCREW +P 2X4	
#10	7-685-781-09	SCREW +PTT 2X4 (S)	

\*\*\*\*\*

ACCESSORIES & PACKING MATERIALS

\*\*\*\*\*

3-044-698-11	MANUAL, INSTRUCTION (ENGLISH, SPANISH, SWEDISH, PORTUGUESE) (1300R: AEP, UK)
3-044-698-21	MANUAL, INSTRUCTION (FRENCH, GERMAN, DUTCH, ITALIAN, GREEK) (1300R: AEP)
3-044-698-31	MANUAL, INSTRUCTION (GERMAN) (1300R: German)
3-044-698-41	MANUAL, INSTRUCTION (ENGLISH, CZECH, POLISH, TURKISH, RUSSIAN) (1300R: South European)
3-868-292-11	CONNECTION, FITTING (ENGLISH, SPANISH, SWEDISH, PORTUGUESE) (AEP, UK)
3-868-292-21	CONNECTION, FITTING (FRENCH, GERMAN, DUTCH, ITALIAN, GREEK) (AEP/C2300R: South European)
3-868-292-31	CONNECTION, FITTING (ENGLISH, CZECH, POLISH, TURKISH, RUSSIAN) (1300R: South European)
3-868-293-11	MANUAL, INSTRUCTION (ENGLISH, SPANISH, SWEDISH, PORTUGUESE) (C2300R: AEP, UK)
3-868-293-21	MANUAL, INSTRUCTION (FRENCH, GERMAN, DUTCH, ITALIAN, GREEK) (C2300R: AEP)

Ref. No.	Part No.	Description	Remark
	3-868-293-31	MANUAL, INSTRUCTION (GERMAN) (C2300R: German)	
	3-868-293-41	MANUAL, INSTRUCTION (ENGLISH, CZECH, POLISH, TURKISH, RUSSIAN) (C2300R: South European)	
	X-3378-453-1	CASE (PANEL) ASSY (for FRONT PANEL)	
*****			
PARTS FOR INTALLATION AND CONNECTIONS			
*****			
501	X-3376-298-1	FRAME ASSY, FITTING	
502	3-041-599-01	COLLAR	
503	1-465-459-21	ADAPTER, ANTENNA	
504	1-776-527-31	CORD (WITH CONNECTOR) (ISO) (POWER)	
505	X-3370-077-1	SCREW ASSY (AE. KEY), FITTING	

