



**SOUND
TECHNOLOGY**



**MODEL
1710A**
OPERATOR AND
SERVICE MANUAL

1400 Dell Avenue, Campbell, California 95008 U.S.A.,

TEL: (408) 378-6540, TELEX: 357445, FAX: (408) 378-6847

ATTENTION

PLEASE SAVE THIS SHIPPING CARTON AND ALL PACKING MATERIALS. THEY HAVE BEEN SPECIFICALLY DESIGNED TO PROTECT YOUR **SOUND TECHNOLOGY** INSTRUMENT.

IF, AT ANY TIME, YOU HAVE REASON TO TRANSPORT YOUR EQUIPMENT, USING THIS CARTON WILL HELP PREVENT DAMAGE.

NEW CARTONS AND PACKING MATERIALS ARE AVAILABLE AT A NOMINAL CHARGE FROM **SOUND TECHNOLOGY**.



SOUND TECHNOLOGY

1400 DELL AVENUE
CAMPBELL, CALIFORNIA 95008
Telephone: (408) 378-6540
Telex: 357445

1700 SERIES METER ZERO ADJUSTMENT

The meter is correctly zeroed when the pointer rests directly over the zero calibration mark on the meter scale. **IMPORTANT:** if the meter is not properly zeroed, calibration accuracy will be affected. To set meter zero:

- a. Turn on unit. Set INPUT switch to 300 VOLTS (100v for 1710A) and FUNCTION switch to VOLTS/POWER. (Make sure Analyzer Select button is out for 1710A).
- b. BALANCED INPUT terminals should be shorted together and grounded to chassis ground.
- c. Rotate meter zero adjustment screw (located just below meter on front panel) until pointer moves up scale when turned cw and down scale when turned ccw. Turn screw cw or ccw until pointer rests directly over the zero calibration mark, then back off screw a very slight amount in the opposite direction to relieve tension on the pointer while maintaining the zero calibration. Repeat adjustment if necessary.

If you have any questions, please contact Sound Technology Customer Service at (408) 378-6540.



**SOUND TECHNOLOGY
MODEL 1710A
DISTORTION MEASUREMENT
SYSTEM**

**SOUND TECHNOLOGY
1400 Dell Avenue
Campbell, CA 95008
Tel: (408) 378-6540
Telex: 357445**

*S-T 1700 Series U.S. Patents:
3940715, 3978401, 4032857.*

Manual Part Number: 7900-0011
Manual printed in U.S.A.
Copyright March 1979

Price: \$ 20.00

WARRANTY

All new Sound Technology products are warranted against defects in materials and workmanship for two years from the date of delivery. Any instrument or component that is found to be defective within the warranty period after examination by Sound Technology or an authorized representative thereof will be repaired or replaced without charge for labor or material. No other warranty is expressed or implied. We are not liable for consequential damages.

Before returning a product to Sound Technology for service, authorization must be obtained from the factory. For products not covered by the warranty, a purchase order should be forwarded to avoid unnecessary delay. Please include instrument model number and serial number with all requests for parts or service to facilitate the fastest possible response.

All products returned to the factory must be shipped prepaid. For products under warranty, Sound Technology will pay for shipment back to the customer.

TABLE OF CONTENTS

	PAGE
SECTION I - OPERATION	1-1
1-1. SCOPE OF SECTION	1-1
1-2. INTRODUCTION	1-1
1-3. INPUT POWER REQUIREMENTS	1-1
1-4. POWER CABLE	1-1
1-5. CONTROLS AND INDICATORS	1-1
1-6. AC Input	1-2
1-7. Sine Wave Generator	1-2
1-8. Total Harmonic Distortion (THD) Analyzer	1-2
1-9. Auto Set Level	1-3
1-10. Intermodulation Distortion (IMD) Analyzer	1-3
1-11. TEST SETUP	1-3
1-12. POWER CONNECTIONS	1-5
1-13. GROUND CONNECTIONS	1-5
1-14. SIGNAL CONNECTIONS	1-5
1-15. Generator	1-5
1-16. Analyzer	1-6
1-17. OPERATING PROCEDURES	1-6
1-18. Test Connections	1-6
1-19. Meter Mechanical Zero Adjustment	1-7
1-20. Frequency Adjustment	1-7
1-21. Impedance/Load Configuration	1-7
1-22. Level Adjustment	1-7
1-23. Distortion Measurement	1-8
1-24. Distortion Measurement with External Oscillator	1-8
1-25. AC Signal Level Measurement	1-9
1-26. Level Ratio Measurements	1-10
SECTION II - PRINCIPLES OF OPERATION	2-1
2-1. INTRODUCTION	2-1
2-2. DISTORTION ANALYZER	2-1
2-3. General Description	2-1
2-4. Buffer Amplifier	2-2
2-5. Overload Detector	2-2
2-6. Notch Filter	2-2
2-7. Distortion Amplifier and Attenuator	2-2
2-8. Amplitude Null Control	2-2
2-9. Phase Null Control	2-3
2-10. Sum Point Buffer	2-3
2-11. Tuning Indicator	2-3
2-12. Filters	2-4
2-13. Function Switches	2-4
2-14. Meter Preamplifier	2-4
2-15. AC Meter	2-4
2-16. GENERATOR	2-4
2-17. General Description	2-4
2-18. Oscillator Circuit	2-4
2-19. Amplitude Control	2-5
2-20. Attenuator	2-7
2-21. Balanced Amplifier	2-8
2-22. POWER SUPPLIES	2-8
2-23. General Description	2-8
2-24. Input Circuit	2-8
2-25. +15 Vdc Supply	2-8
2-26. -15 Vdc Supply	2-8
2-27. +17 Vdc Supply	2-8
2-28. -17 Vdc Supply	2-9
2-29. Floating Ground Supply	2-9
2-30. Electromagnetic Interference Considerations	2-9

TABLE OF CONTENTS continued

SECTION III - MAINTENANCE

3-1.	INTRODUCTION.	3-1
	PART 1 - BASIC SYSTEM OPERATION.	3-1
3-2.	PERFORMANCE CHECK	3-1
3-3.	TROUBLESHOOTING	3-2
3-4.	SYMPTOM/CAUSE TABLE	3-3
	PART 2 - COMPLETE SYSTEM CHECK	3-3
3-5.	TEST EQUIPMENT.	3-3
3-6.	INTRODUCTION.	3-3
	3-7. Circuit Common Isolation Check	3-3
	3-8. Frequency and Level Check.	3-3
	3-9. Distortion Test.	3-8
	3-10. Balance Check.	3-8
	3-11. Vernier Level Control Range Check.	3-9
	3-12. 1 and 0.1 dB-Per-Step Level Controls	3-9
	3-13. +26 and +20 dBm Level Checks	3-10
	3-14. 10 dB-Per-Step Level Control, Balanced Loads	3-10
	3-15. 10 dB-Per-Step Level Control, Unbalanced Loads	3-11
	3-16. dB Volts Test.	3-11
	3-17. Volts Power Test	3-12
	3-18. Filters Test	3-12
	3-19. Residual Noise Test.	3-13
	3-20. Common Mode Rejection Test	3-13
	PART 3 - ADJUSTMENT and CALIBRATION PROCEDURE.	3-14
3-21.	INTRODUCTION.	3-14
	3-22. -17 Volt Adjustment.	3-14
	3-23. +17 Volt Adjustment.	3-14
	3-24. Oscillator Photocell Adjustment.	3-14
	3-25. Oscillator Integrator Voltage Change Adjustment.	3-15
	3-26. Oscillator Integrator Output Adjustment.	3-15
	3-27. Oscillator x1000 Frequency Range Adjustment.	3-15
	3-28. Amplifier Balance.	3-15
	3-29. Vernier Attenuator Range	3-16
	3-30. +15 Volt Adjustment.	3-17
	3-31. -15 Volt Adjustment.	3-17
	3-32. DC Zero Adjustment	3-17
	3-33. Null Adjustment.	3-17
	3-34. Phase Null Integrator Voltage Adjustment	3-18
	3-35. Tuning Indicator	3-18
	3-36. Calibration at 1 kHz	3-19
3-37.	COMPONENT REPLACEMENT-CALIBRATION AND ADJUSTMENT.	3-19
	PART 4 - REPLACEMENT and REPAIR.	3-20
3-38.	SPECIAL PRECAUTIONS	3-20
3-39.	WIRING.	3-20
3-40.	SOLDERING TECHNIQUES.	3-20
3-41.	COMPONENT REPLACEMENT	3-21
	3-42. Multi-Lead Devices	3-21
	3-43. Potentiometers	3-21
	3-44. Analyzer Power Supply.	3-21
3-45.	OSCILLATOR ACCESS	3-21
3-46.	FREQUENCY MODULE REPAIR	3-22
	3-47. Repair and Replacement	3-22
	3-48. Repair Instructions.	3-23

SECTION IV - DIAGRAMS

4-1.	INTRODUCTION.	4-1
4-2.	SCHEMATIC DIAGRAMS.	4-1
4-3.	COMPONENT LOCATION DIAGRAMS	4-1

SECTION V - SPARE PARTS

5-1.	INTRODUCTION.	5-1
5-2.	ORDERING INFORMATION.	5-1

SECTION 1 OPERATION

1-1. SCOPE OF SECTION

This section contains information and instructions necessary for the operation of the Sound Technology Model 1710A Distortion Measurement System. Included are power requirements, cabling information and operating instructions.

1-2. INTRODUCTION

The Model 1710A Distortion Measurement System combines a flexible ultra-low-distortion sine-wave signal generator, a high-resolution automatic-measuring total harmonic distortion (THD) analyzer, and an accurate ac-level meter in one instrument. Pushbutton operation permits the operator to quickly measure voltage or power levels, set level, and then measure distortion.

The generator section provides a pure sine-wave oscillator signal for testing from 10 Hz to 110 kHz. The generator output is direct-coupled (no transformer) and is balanced and floating with respect to ground. Either side can be grounded without any level change. The output impedance can be set to either 150 ohms or 600 ohms (except for levels greater than +21 dBm), and discrete calibrated levels in 0.1 dB steps can be selected from +27.0 dBm to -90.9 dBm (decibels relative to 1 milliwatt into 600 ohms) into 150-ohm or 600-ohm loads (17.32 V rms maximum). The level across any load used can, in addition, be directly measured within the instrument. An indicating off switch disables the generator for convenient signal-to-noise ratio (SNR) measurements.

The analyzer section contains a tracking notch filter which is always tuned to the generator's frequency. The analyzer measures total harmonic distortion with a sensitivity ranging from 100 percent to .01 percent full scale, with automatic nulling on all ranges. Active filters may be selected for hum and noise suppression, enhancing the measurement resolution. A differential front end rejects common-mode noise.

The ac signal-level meter in the analyzer measures ac voltage, or power in dBm. The measurement range for ac voltage is 0.1 millivolts to 100 volts full scale (30 microvolts using the RATIO switch described in paragraph 1-25), and for power is -80 dBm to +40 dBm full scale (-90 dBm using the RATIO switch described in paragraph 1-25). Ratio measurements with 100 dB or more of dynamic range can also be made.

1-3. INPUT POWER REQUIREMENTS

The Model 1710A System may be operated from nominal 115-volt (90 to 130) or 230-volt (180 to 260), 50 or 60-Hz power sources. A two-position selector switch on the rear panel selects the nominal voltage; before connecting the instrument to the power outlet, check that the selector switch setting matches the voltage of the source.

The Model 1710A System is protected from ac power overloads by a fuse (1A, fast-blow) located in a cartridge-type fuse holder on the rear panel.

1-4. POWER CABLE

The International Electrotechnical Commission (IEC) recommends that instrument panels and cabinets be grounded to protect operating and servicing personnel. The Model 1710A system is equipped with an IEC-approved three-conductor power cable assembly which, when plugged into an appropriate outlet, effectively grounds the unit.

1-5. CONTROLS AND INDICATORS

The data sheet at the front of this manual illustrates and describes briefly the Model 1710A Distortion Measurement System's front panel controls and indicators. The following provides additional explanatory information.

1-6 AC INPUT

- a. POWER ON switch -- Connects ac Power to Model 1710A System.

1-7 SINE WAVE GENERATOR

- a. FAST RESPONSE/LOW DISTORTION switch -- Selects operating mode of oscillator. FAST RESPONSE causes oscillator amplitude to settle quickly after a frequency change. This mode is recommended when ultra-low distortion measurements are not required, for example when making frequency response measurements. LOW DISTORTION selects full ultra-low distortion capability of oscillator. The settling time in this mode is less than 5 seconds. Actuation of the FREQUENCY pushbuttons generally causes the oscillator to go first to the Fast Response mode and then settle in Low Distortion mode. This switch controls only the oscillator and is not connected to the analyzer.
- b. OSC FAST RESPONSE indicator -- Indicates operating mode of oscillator. When lit, oscillator is in Fast Response mode and does not have ultra-low distortion.
- c. FREQUENCY pushbuttons -- Simultaneously select generator and total harmonic distortion analyzer frequency. Four multiplier switches and 30 digit switches permit 3-digit resolution within each range. Frequency range of Model 1710A system is 10 Hz to 109.9 kHz. One button on each row must be pressed at all times.
- d. OFF switch -- Disconnects the generator while maintaining the source termination of the output terminals at 150, 600 or zero ohms (+26 dBm position on 10dB switch)
- e. GENERATOR LEVEL switches -- Allow selection of calibrated output levels into 150-ohm or 600-ohm loads when VERNIER control is at mid-rotation. These levels are from + 26.0 dBm to - 89.9 dBm (Note that since the VERNIER controls has a range of ± 1 dBm from this midpoint setting, the full range is from + 27.0 dBm to - 90.0 dBm.) For other load impedances, output levels are not calibrated but may be measured directly across the load by placing the ANALYZER SELECT switch in the OUTPUT position while using the analyzer in the VOLTS/POWER function. Signal clipping can occur for loads of less than 150 ohms in the +26 dBm position on the 10 dB switch (the generator source impedance is fixed close to zero ohms).
- f. VERNIER control -- Varies the output level linearly ± 1 dB from nominal.
- g. OSC Δ F control -- Varies the oscillator frequency by $\pm 3/4$ of the least significant digit. This setting does not affect the nominal center frequency of the total harmonic distortion analyzer, nor its ability to null on the generator signal.
- h. GENERATOR OUTPUT terminals -- Provide direct-coupled and balanced generator output with a mid-point reference (CT) terminal. Output floats with high isolation with respect to chassis ground. Generator GND terminal is fused on rear panel (1/32 A, fast-blow).
- i. SOURCE IMPEDANCE switch -- Provides 150-ohm or 600-ohm source impedance as selected, except that source impedance is near zero ohms when + 26 dBm position of most-significant GENERATOR LEVEL switch is selected.

1-8 TOTAL HARMONIC DISTORTION (THD) ANALYZER

- a. INPUT terminals -- Provide connection for external signal being measured.
- b. VOLTS/POWER pushbutton -- Selects ac level measurement function.
- c. SET LEVEL pushbutton -- Selects Set Level function whereby meter displays reference signal level for Total Harmonic Distortion or Ratio measurements.
- d. THD pushbutton -- Selects Total Harmonic Distortion measurement function.
- e. dB VOLTS pushbutton -- Selects Ratio measurement function.

- f. ANALYZER SELECT/GENERATOR OUTPUT switch -- Selects the input to the analyzer circuits from the INPUT terminals or the GENERATOR OUTPUT TERMINALS.
- g. INPUT switch -- Selects full-scale meter range for ac level measurement function. Readings are in volts rms or dBm (600 ohms). Also selects input range for Total Harmonic Distortion and Ratio measurement functions.
- h. RATIO switch -- Selects full scale meter range for Distortion and Ratio measurement functions. Readings are in percent or dB.
- i. OVERLOAD indicator -- Lights when INPUT switch setting is too low or when ADJUST control is set too far clockwise. This warns operator that measurement is no longer accurate.
- j. SET LEVEL ADJUST control -- Adjusts reference signal level for Total Harmonic Distortion or Ratio measurement. When control is set to CAL position (maximum counterclockwise, before selection of Auto Set Level, if provided) RATIO ranges extend level measurement to 30 Microvolts or -90 dBm full scale (refer to paragraph 1-25).
- k. FILTERS -- HUM pushbutton selects a filter which suppresses low-frequency signals THD/VOLTS (such as 60-Hz hum) below 400 Hz. NOISE pushbutton selects a filter which suppresses high-frequency noise above 30 kHz or 80 kHz, as selected. The NOISE filter helps reduce effects of AM radio station pickup. The HUM filter is usable with fundamental frequencies down to 400 Hz when making distortion measurements. Both filters affect readings only on Distortion and Ratio measurement functions. They do not affect meter readings on VOLTS/POWER, and Set Level measurement functions.
- l. NOTCH frequency indicators -- Facilitate analyzer tuning when using an external oscillator. When LOW indicator is lit, analyzer frequency is low with respect to incoming signal; when HIGH indicator is lit, analyzer frequency is high with respect to incoming signal. Analyzer is correctly tuned when both indicators are extinguished. (It is normal for one of these indicators to glow when there is no signal input to the Model 1710A.)
- m. METER -- Indicates signal level of measurement selected by ANALYZER function pushbutton.
- n. INPUT MONITOR BNC connector -- Provides replica of input signal being analyzed. This signal is referenced to ground and intended to be connected to an oscilloscope. Output is 316 millivolts for full-scale meter deflection in Set Level mode with INPUT range switch equal to or more than 0.3 V.
- o. OUTPUT MONITOR BNC connector -- Provides replica of distortion products of signal being analyzed (suitable for viewing on oscilloscope) on VOLTS/POWER, SET LEVEL and DISTORTION measurement functions. On Ratio measurement function, this output provides a scaled version of input signal. Output is 31.6 millivolts for full-scale meter deflection, and is referenced to ground.

1-9. AUTO SET LEVEL

Refer to Appendix A for a description of this control.

1-10. INTERMODULATION DISTORTION (IMD) ANALYZER

Refer to Appendix B for a description of the IMD Analyzer controls.

1-11. TEST SETUP

In order to take full advantage of the ultra-low distortion measuring capabilities of the Model 1710A system, it is extremely important that the cabling between the Model 1710A, the device under test, and other test equipment be connected in compliance with the arrangement shown in Figure 1-1 and described in the following paragraphs. The connections and controls numbered in Figure 1-1 are similarly identified in the text. These connections have been found to provide the optimum test setup in most cases.

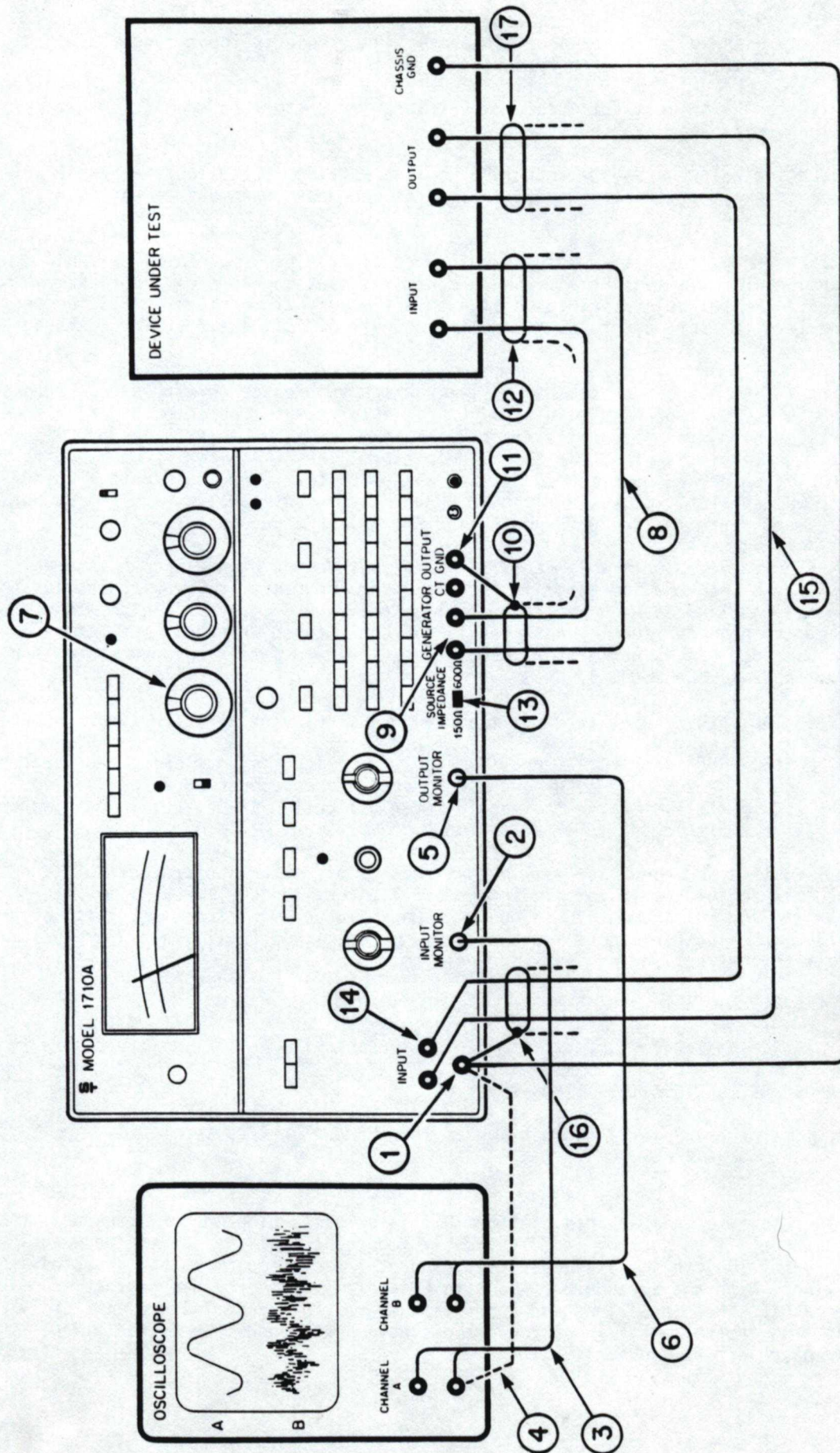

Figure 1-1. Model 1710A Test Setup

1-12. POWER CONNECTIONS

- a. Check that the power slide switch on the rear panel of the Model 1710A is set to the correct position for the available ac power (see paragraph 1-3 for details).
- b. Do not float the earth ground of the power cord of the Model 1710A. (The analyzer's differential input makes this step unnecessary for breaking ground loops.)
- c. Plug the Model 1710A, the device under test, and the oscilloscope (if used) into the ac power bus as closely together as possible.

1-13. GROUND CONNECTIONS

- a. Connect the Model 1710A GND terminal at the analyzer input (1) to the ground terminal, or chassis ground, of the device under test using as short a lead as possible of at least No. 18 AWG stranded wire. This reduces common-mode potential between these two devices. In a strong hum or RF field, this connection is essential.
- b. Connect the oscilloscope (if used) to the INPUT MONITOR BNC connector (2) on the Model 1710A via cable (3).

NOTE

- (1) This output is from the differential to single-ended converter in the Model 1710A which provides a replica of the input signal. This signal is referenced to ground.
- (2) If a BNC cable is not used for this connection, the oscilloscope common (low) terminal must be returned to the Model 1710A GND terminal (1) via a direct connection (4).

1-14. SIGNAL CONNECTIONS

Connect the oscilloscope (if used) to the OUTPUT MONITOR (5) via cable (6). This permits monitoring the distortion products of the signal being analyzed.

1-15. GENERATOR

- a. Set the OUTPUT IMPEDANCE selector switch (13) to 150 ohms or 600 ohms as desired for the device under test.
- b. Set the 10 dB level switch (7) of the GENERATOR LEVEL controls to -80 dBm or to a known safe operating input level for the device under test. The other level switches, as well as the VERNIER control and the OFF switch, can be at any setting at this time.
- c. Connect the shielded twisted-pair cable (8) between the GENERATOR OUTPUT terminals (9) and the input terminals of the device under test. The shield (10) of this cable should be connected to the GENERATOR OUTPUT GND terminal (11) only, and not to the chassis of the device under test (12).

NOTE

- (1) In environments with high electrical or radio-frequency noise, it may be necessary to use a shielded dual banana-plug connector such as the Pomona Type 1921 at the GENERATOR OUTPUT terminals, as well as an appropriate shielded connector at the input to the device under test.
- (2) If the input to the device under test is single-ended, convert the balanced output to unbalanced by connecting a short wire (about 1 inch) between the generator GND terminal and the adjacent output terminal. Once this ground connection is made, a single conductor shielded cable can be used to feed signal into the device under test.
- (3) Be certain that no significant voltages will be presented to the GENERATOR OUTPUT terminals from the device under test. Voltages greater than 7 volts rms across the balanced output, greater than 5 volts rms from either balanced output terminal to the CT terminal, or greater than 200 volts rms between any of the output

terminals and chassis ground may lead to permanent attenuator resistor and/or semiconductor damage. No fusing of these signal lines is provided so that signal distortion can be kept to a minimum.

1-16. ANALYZER

- a. Set the INPUT switch to 100 V or expected range and select the VOLTS/POWER function.
- b. Set the ANALYZER SELECT switch to INPUT (out position).
- c. Connect the output of the device under test to an appropriate load resistor, if required.

NOTE

This load resistor and the output connections should be made in a location free from any ac magnetic fields, such as caused by power transformers, to avoid hum pickup.

- d. Connect the output of the device under test to the analyzer INPUT terminals (14) with the shielded twisted-pair cable (15). Connect the shield (16) of this cable to the INPUT GND terminal (1); do not connect the shield (17) at the device under test.

NOTE

- (1) In environments with high electrical or radio-frequency noise it may be necessary to use a shielded dual banana-plug connector such as the Pomona Type 1921 at the analyzer INPUT terminals, as well as an appropriate shielded connector at the output of the device test.
- (2) Each INPUT terminal has its own input attenuator and buffer amplifier. Input impedance is 100 Kilohms from each terminal to the Model 1710A System ground. The true differential input circuits of the Model 1710A System help break the ground loop that causes 60-Hz pickup on the input leads of most measuring equipment.
- (3) Do not connect one channel of the oscilloscope directly to the output of the device under test as this can reduce the noise rejection capability of the Model 1710A System differential input circuitry. If it is absolutely essential to monitor this signal, leave the ground lead of the scope channel disconnected from the device under test.

1-17. OPERATING PROCEDURES

CAUTION

DO NOT EXCEED THE FOLLOWING ANALYZER INPUT VOLTAGES, TO PREVENT BLOWING FUSES F1 and F2, located inside the 1710A. With INPUT range switch set to 3V or lower:

- (1) 300 V below 60 Hz
- (2) 50 V above 1 kHz

1-18. TEST CONNECTIONS

Before making measurements with the Model 1710A System, ensure that the equipment has been connected as shown in figure I-1 and following the instructions given in paragraphs 1-13 through 1-16.

1-19. METER MECHANICAL ZERO ADJUSTMENT

The meter is correctly set when the pointer rests over the zero calibration marks on the scale when the Model 1710A INPUT switch is set to 100 V, the SET LEVEL pushbutton is pressed, and there is no input signal (input leads disconnected). To adjust the zero set: Rotate the zero adjustment screw (located on the front panel below the meter) until the pointer is left of zero. (This may require either CW or CCW rotation.) Reverse rotation until the pointer is exactly at zero.

1-20. FREQUENCY ADJUSTMENT

- a. Four Multiplier pushbuttons (X1, X10, X100 X1000) and 30 Digit pushbuttons permit 3-digit resolution of frequency selection. For example, 453 Hz is selected by pressing the following pushbuttons:

<u>Multiplier</u>	<u>1st Digit</u>	<u>2nd. Digit</u>	<u>3rd. Digit</u>	<u>Frequency</u>
X10	40			40X10=400
		5		5X10= 50
			.3	.3X10= 3
				453 Hz

The "100" Digit pushbutton provides a 10 percent overlap in range. For Example, 1010 Hz can be selected in two ways:

<u>Multiplier</u>	<u>1st. Digit</u>	<u>2nd. Digit</u>	<u>3rd. Digit</u>	<u>Frequency</u>
X10	100			100X10=1000
		1		1X10= 10
			0	0X10= 0
				1010 Hz
X100	10			10X100=1000
		0		0X100= 0
			.1	.1X100= 10
				1010 Hz

- b. In the X1 range, operation of the frequency pushbuttons may not always cause the oscillator to go through its automatic stabilization cycle. If the oscillator amplitude appears to be unstable, momentarily set the FAST RESPONSE/LOW DISTORTION switch to the FAST RESPONSE position and then return it immediately to the LOW DISTORTION setting.
- c. The OSCΔF control can be used to provide frequency resolution between digitally-selected values.

1-21. IMPEDANCE/LOAD CONFIGURATION

With the SOURCE IMPEDANCE select switch set to 150 ohms or 600 ohms, the generator is matched to either of these load impedances except when the most significant GENERATOR LEVEL control is set to +26 dBm. The matched condition will exist for balanced or unbalanced loads, as long as the signal connections of paragraph 1-13 through 1-16 are used. For load impedances other than 150 ohms or 600 ohms, source matching can no longer be achieved and the output configuration must be considered as a voltage divider with a source impedance as selected; the degree of balance will not be affected by other load impedances.

1-22. LEVEL ADJUSTMENT

- a. For 150 or 600 ohms
- (1) Center the GENERATOR LEVEL VERNIER control.
 - (2) Set the GENERATOR OFF switch to the on (out) position.
 - (3) Adjust the GENERATOR LEVEL switches for the desired level.

NOTE

The 1 dB/step and 0.1 dB/step switches always subtract numerically from the level indicated in the most-significant level switch ; i.e.:

+20	-3	-.7	=	+16.3	dBm
-50	-4	-.2	=	-54.2	dBm

- b. To confirm the actual signal level presented to the load, set the ANALYZER SELECT switch to GENERATOR OUTPUT, and using the VOLTS/POWER function, directly measure the output level in volts or dBm (600 ohms).

1-23. DISTORTION MEASUREMENT

To measure the total harmonic distortion (THD) of a device under test, proceed as follows:

- a. Set the FAST RESPONSE/LOW DISTORTION switch to LOW DISTORTION and select the fundamental test frequency in Hz by depressing the appropriate FREQUENCY pushbuttons.
- b. Press VOLTS/POWER pushbutton and set the ADJUST control fully CCW to CAL position.
- c. Set the INPUT switch to the expected range.
- d. Set the ANALYZER SELECT switch to INPUT (out position).
- e. Adjust the GENERATOR LEVEL controls for the desired input level to the device under test, or for the desired output level as indicated on the Model 1710A meter. Up range the INPUT switch when the meter pointer passes full scale and down range when the meter pointer goes below 1/3 of full scale. An input level of at least 0.1 V is needed for THD measurements.
- f. For percentage THD measurements, press the SET LEVEL pushbutton and rotate the ADJUST control until the meter pointer rests on the full-scale mark. (If auto set level is to be used, replace this step with rotation of the ADJUST control fully CCW past the click to AUTO.)

NOTE

If distortion is to be measured in dB, the ADJUST control should be rotated until the meter pointer rests on the 0dB mark; this will require upranging of the INPUT switch one step if the initial level reading is above this scale point. (Auto Set level always adjusts for full-scale reference, and requires the addition of 2dB to dB THD readings made using this feature.)

- g. Press the DISTORTION pushbutton and rotate the RATIO switch until the meter pointer reaches the upper 2/3's of scale. If desired, press the HUM or NOISE (30 Hz or 80 KHz FILTER pushbuttons to filter noise from the input signal.
- h. Observe the distortion either in percentage or dB, as indicated by the meter deflection and the RATIO switch setting.

1-24. DISTORTION MEASUREMENT WITH EXTERNAL OSCILLATOR

- a. Connect the equipment as shown in Figure 1-1, with the following exceptions:
 - (1) If possible, connect the power cord of the external oscillator to a main power source close to the source used by the Model 1710A, the device under test, and the oscilloscope.
 - (2) Connect the output of the oscillator to the input of the device under test. The oscillator output may be floated if this gives better test results.
 - (3) If possible, connect the chassis of the oscillator to the analyzer GND terminal of the Model 1710A.

- b. Set the external oscillator to the desired frequency. Set its output level to minimum.
- c. Preset the Model 1710A FREQUENCY pushbuttons to the approximate frequency of the external oscillator.
- d. Set the ADJUST control fully counterclockwise (CCW) to the CAL position and press the VOLTS/POWER pushbutton.
- e. Set the INPUT switch to the desired input level.
- f. Set the ANALYZER SELECT switch to INPUT.
- g. Adjust the external oscillator amplitude control for the desired input level to the device under test or for the desired output level from it, as indicated on the Model 1710A meter. Input level must be in the upper 2/3 of meter scale and at least 0.1V.
- h. Press the SET LEVEL pushbutton. Rotate the ADJUST control until the meter pointer rests at full scale. (If auto set level is to be used, replace this step with rotation of the ADJUST control fully CCW past the click to AUTO position.)
- i. Set the Model 1710A frequency or the external oscillator frequency so both NOTCH FREQUENCY indicators are off and the tuning is approximately centered.
- j. Press the DISTORTION pushbutton and set the RATIO switch for an on-scale meter reading as high as possible. If desired, press the HUM or NOISE (30 or 80 kHz) FILTER.
- k. Observe the distortion in either percentage or dB, as indicated by the meter deflection and the RATIO switch range setting.

1-25. AC SIGNAL LEVEL MEASUREMENT

The Model 1710A is an accurate ac level meter over its entire frequency range. The power scale is calibrated in dBm across a 600-ohm load. Voltage may be measured directly from 0.1 millivolt to 100 volts full scale and power from -20 dBm to +40 dBm full scale. To measure ac voltage or power, proceed as follows:

- a. Ensure that the power and ground connections are as described in paragraphs 1-12 and 1-13 respectively.
- b. Connect the signal to be measured as described in paragraph 1-16.
- c. Set the ADJUST control to CAL position and press the VOLTS/POWER pushbutton.
- d. Rotate the INPUT switch for an on-scale reading with the pointer in the upper 2/3's of the meter scale.

NOTE

The HUM and NOISE FILTERS do not affect readings in the VOLTS/POWER measurement mode.

- e. The sensitivity of the ac voltmeter can be extended to 30 microvolts full scale through the use of the RATIO switch. To obtain this increased sensitivity, carry out the following steps:

- (1) Set the Model 1710A controls as follows:

dB VOLTS switch	-----	in
INPUT switch	-----	.3 V
ADJUST control	-----	CAL

- (2) Meter full scale sensitivity is now controlled by the RATIO switch as follows:

<u>RATIO switch</u>	<u>Full Scale Sensitivity</u>
-80 dB	30 μ V
-70 dB	100 μ V
-60 dB	300 μ V
-50 dB	1 mV

NOTE

The HUM and NOISE FILTERS will affect meter readings in this mode of operation.

1-26. LEVEL RATIO MEASUREMENTS

The dB Volts function facilitates the measurement of voltage ratio, signal-to-noise ratio, and frequency response, in dB or percent. The signal-to-noise ratio measurement using the internal sine-wave generator of the Model 1710A as described below provides an example of the use of this function.

- a. Ensure that connections are as described in paragraphs 1-13 through 1-16, and Figure 1-1.
- b. Set the ADJUST control to the CAL position and press the VOLTS/POWER pushbutton.
- c. Set the INPUT switch to the expected signal range and adjust the appropriate signal-level controls for the desired output signal, as indicated on the meter.
- d. Press the SET LEVEL pushbutton and rotate the ADJUST control until the meter pointer rests on the 0 dB mark for dB ratio measurements or on full scale mark for percentage ratio measurements.

NOTE

For proper 0 dB or 100 percent set level, the reference signal must be at least 0.1 V and not exceed 100 V.

This step must be carried out manually; Automatic Set Level cannot be used for this measurement.

- e. Remove input signal to the device under test by pressing the OFF pushbutton.
- f. Press the dB VOLTS pushbutton. Select the RATIO switch range which places the meter pointer in the upper 2/3's of scale if possible. Read signal-to-noise ratio (SNR) as indicated by the meter deflection and the RATIO switch range setting.

SECTION II
PRINCIPLES OF OPERATION

2-1. INTRODUCTION

The Model 1710A Distortion Measurement System consists of a flexible ultra-low-distortion sine-wave signal generator, a high-resolution automatic-measuring total harmonic distortion (THD) analyzer, an accurate ac-level meter, and dc power supplies. Pushbutton operation permits the operator to quickly measure voltage or power levels, set level, and measure distortion.

The system makes total harmonic distortion measurements by applying a sine-wave of ultra-low distortion from the generator to the input of the device under test while the distortion analyzer measures the output from the device under test. A tuneable notch filter in the analyzer, mechanically ganged to the generator by the front panel frequency-select switches, suppresses the fundamental signal. Automatic nulling circuitry fine tunes the notch filter and ensures that the null is retained. The signal remaining at the output of the notch filter consists of the distortion products and noise. This is displayed by the average-reading volt-meter in the analyzer. The ratio of the measured distortion components to a previously set fundamental signal reference level is defined as the total harmonic distortion and can be read out directly on the meter in percent or dB. Switchable hum and noise filters are provided to enhance the readout of the harmonic products.

2-2. DISTORTION ANALYZER

2-3. GENERAL DESCRIPTION

Refer to Section IV for a schematic diagram of the distortion analyzer assembly. Note that the circuit is divided into the following circuit blocks: Buffer amplifier, overload detector, notch filter, distortion amplifier and attenuator, amplitude null filters, function switches, and ac meter. The operation of the assembly is discussed first at a circuit block level and is then followed by details of each block.

In operation, the signal to be measured from the ANALYZER SELECT switch is connected to the input of the buffer amplifier. The buffer amplifier has two outputs, a fixed output which may be connected to the ac voltmeter, and a variable output (controlled by the ADJUST control) which is connected to the notch filter. The voltmeter is an average reading type which measures the signal level selected by the appropriate function switch.

The overload detector monitors the variable output of the buffer amplifier. If an excessively high output voltage is detected, the detector turns on the front panel OVERLOAD indicator.

The notch filter is mechanically ganged to the oscillator frequency select switches and suppresses the fundamental from the output of the buffer amplifier. The output of the notch filter is connected to the input of the distortion amplifier through a step attenuator controlled by the front panel RATIO switch. The attenuator adjusts a signal level for the distortion amplifier for various percentages of distortion or ratio readings.

The amplitude null control and phase null control circuits supply the notch filter with its automatic nulling feature. Both circuits monitor the output of the distortion amplifier and feed control signals back to the notch filter.

The sum-point buffer supplies reference signals to the tuning indicator and to the amplitude null control circuit.

The tuning indicator circuit, using frequency information from the notch filter, provides the operator with a visual indication of the frequency being analyzed versus the input frequency. This circuit operates the NOTCH filter HI and LO indicators.

The switchable HUM and NOISE filters are connected to the output of the distortion amplifier. These filters are effective on DISTORTION and dB VOLTS measurements.

The function switches select the circuit to be measured by the ac voltmeter. When the VOLTS POWER switch is depressed, the meter monitors the fixed output from the buffer amplifier via a stepped attenuator and preamplifier. When the SET LEVEL switch is depressed, the meter monitors the variable output from the buffer amplifier. Operation of the THD switch routes the signal from the distortion amplifier via the HUM and NOISE filters (if selected) to the meter. When the dB VOLTS switch is depressed, it connects the variable output from the buffer amplifier directly to the attenuator at the input of the distortion amplifier and hence to the meter.

2-4. BUFFER AMPLIFIER

The input of the buffer amplifier contains a pair of step attenuators, one for each INPUT connector. The attenuators are controlled by Sections S1A, B, C, D of the INPUT switch. The attenuator outputs are connected to input signal preamplifiers U101 and U102. The gain of these units is controlled by section S1E of the INPUT switch. Gain is unity on the 3 V range and above, 3.16 on the 1 V range, and 10 on the .3 V range and below. The preamplifier outputs are coupled to U103, a bridge amplifier circuit which effectively acts as a differential to single-ended converter with high common-mode noise rejection. The gain of the bridge amplifier is controlled by ADJUST potentiometer R125 and provides the variable signal supplied by the buffer. The range of gain is 10 dB and full scale voltage is 3.16 volts. The fixed output from the buffer is obtained between the wiper of R125 and ground. This signal remains fixed regardless of the setting of R125, except when the buffer overloads.

2-5. OVERLOAD DETECTOR

The overload detector signals an overload condition when the variable output of the buffer amplifier exceeds approximately 6.5 volts rms sine wave or 9 volts peak. The circuit consists of comparator U107, a half-wave rectifier and filter, a light-emitting diode driver, and OVERLOAD indicator CR120.

2-6. NOTCH FILTER

The notch filter consists of two 90-degree phase shifters connected in series, making the output 180 degrees out of phase with the input. By summing the input and output at summing amplifier U203, the fundamental of the input signal is cancelled out. Feedback from the output of the summing amplifier to the input of the filter increases the Q of the circuit and narrows the rejection band of the filter.

Tuning is controlled by changing a set of RC elements for each phase shifter through operation of the front panel Multiplier and Digit pushbutton switches. When the reactance of the capacitance equals the resistance at the incoming frequency, the phase shift is 90 degrees. The RC components are contained in the frequency module (See section IV for schematic diagram).

2-7. DISTORTION AMPLIFIER AND ATTENUATOR

The output of the notch filter is coupled through a 7-step attenuator to the input of distortion amplifier U204. The attenuator is controlled by section S2D of the front panel RATIO switch and reduces the distortion product of the notch filter such that the full scale voltage input to the amplifier is 1 mV on ranges .03% through 100% and .316 mV on the .01% range.

Amplifier U204 is a wide-band high-gain unit with gain controlled by section S2E of the RATIO switch. The gain is 31.6 for ranges .03% through 100% and 100 for the .01% range. This gives a full scale output voltage of 31.6 mV on all ranges.

2-8. AMPLITUDE NULL CONTROL

The amplitude null control circuit controls the amplitude of the signal from the cascaded phase shifter so that exact balance occurs when it is summed with the input to the phase shifters. This ensures the total cancellation of the fundamental signal. The components which perform this function include phase detector U310, floating integrator and voltage follower U312, integrating amplifier U311, integrating capacitors, and a photocoupler controlling a variable resistor element in the summing network.

The reference input to phase detector U310 is a signal which is in phase with the fundamental, and the signal input to U310 is the distortion product output of the distortion amplifier. With these inputs, the phase detector monitors the notch filter output for an in-phase signal. When this occurs, the output of the phase detector supplies drive to the integrator causing the charge on the integrating capacitors to change. This in turn causes the photocoupler to change the value of the variable resistor which in effect adjusts the summing current until the in-phase component is no longer there.

The integrating capacitors are changed by the RATIO attenuator switch. This in effect maintains the automatic null control loop gain at a relatively constant level, resulting in high-speed nulling on all ranges. The capacitors are precharged to the integrator output voltage level through resistor R360. This avoids switching transients and improves the speed of the circuit.

2-9. PHASE NULL CONTROL

The phase null control circuit fine tunes the phase of the second phase shifter in the notch filter so that the overall phase shift is exactly 180 degrees. This ensures total cancellation of the fundamental signal. The components which perform this function include phase detector U307, floating integrator and voltage follower U309, integrating capacitors, and a photocoupler controlling a variable resistor in the resistive branch of the second phase shifter.

The reference input to phase detector U307 is a signal which is out of phase with the fundamental, and the signal input to U307 is the distortion product output of the distortion amplifier. With these inputs the phase detector monitors the notch filter output for an out-of-phase signal. When this occurs, the phase detector output supplies drive to the integrator causing the charge on the integrating capacitors to change. The integrator output drives the variable gain amplifier, U313, and the voltage to current converter, U314, which in turn causes the photocoupler to change the value of the variable resistor which in effect adjusts the phase angle until the out-of-phase component is no longer there.

The integrating capacitors are changed by the RATIO attenuator switch. This in effect maintains the automatic null control loop gain at a relatively constant level, resulting in high-speed nulling on all ranges. The capacitors are precharged to the integrator output voltage level through resistor R344. This avoids switching transients and improves the speed of the circuit.

A set of resistors that feed signal from integrator U308 to U313, which acts as a gain control, is switched by the front panel FREQUENCY switches. This maintains a relatively constant integrator voltage when frequency is changed and helps to achieve perfect nulling in less than 5 seconds.

2-10. SUM-POINT BUFFER

The sum-point buffer supplies a signal from the notch filter summing point to the tuning indicator and the amplitude null control, each of which uses the signal as the reference input of a phase detector. The buffer consists of unity-gain amplifier U301 and high-gain high-speed amplifier U302. These components convert the sine wave at the summing point into a square wave signal.

2-11. TUNING INDICATOR

The tuning indicator monitors the phase relationship between the signal input to the notch filter's first phase shifter and its output. The relationship is frequency dependent and is 90 degrees when the incoming frequency is exactly the same as the tuned frequency of the notch filter. The components performing this function include phase detector U303, high-speed amplifier/drivers U304, U305 and HIGH and LOW indicators CR301, CR302.

The reference input to phase detector U303 is the signal at the input to the phase shifter (connected via the sum-point buffer) and the signal input to U303 is the output of the phase shifter. When the incoming frequency is exactly the same as the tuned frequency of the notch filter (90-degree phase relationship), there is no output from the phase detector. Under these conditions both indicators are off. However, if the frequency of the notch filter is high compared with the input frequency, U303 produces a dc output which turns on the HIGH indicator. Conversely, if the frequency of the notch filter is low compared with the output frequency, a dc output of the opposite polarity from U303 turns on the LOW indicator.

2-12. FILTERS

Each filter is an active 3-pole Butterworth having a flat response within its passband and an attenuation slope of -18 dB/octave. The -3 dB point is switch selectable at 30 kHz or 80 kHz for the low-pass NOISE filter and at 400 Hz for the high-pass HUM filter.

2-13. FUNCTION SWITCHES

The function switches select the circuit to be measured by the ac voltmeter. When the VOLTS POWER switch is depressed, the meter monitors the fixed output, via a step attenuator, from the buffer amplifier. When the SET LEVEL switch is depressed, the meter monitors the signal from a divider connected to the variable output of the buffer amplifier. Operation of the THD switch routes the signal from the distortion amplifier via the low-frequency and high-frequency filters (if selected) to the meter. This connection is not made directly by the THD switch but by the release of the SET LEVEL and VOLTS POWER switches which occurs automatically when the THD switch is depressed. When the dB VOLTS switch is depressed, it connects the variable output from the buffer amplifier directly to the attenuator at the input of the distortion amplifier and hence to the meter.

2-14. METER PREAMPLIFIER

The ac meter preamplifier has a gain of 30 db and is in use only when the VOLTS/POWER measurement function is selected. This provides an overall sensitivity for the VOLTS/POWER measurement of 100 microvolts (-80 dBm) full scale.

2-15. AC METER

The ac meter circuit consists of high-gain wide-band amplifier U104, a full-wave bridge rectifier circuit, and dc milliammeter M1. It indicates the average value of an ac signal. The input sensitivity is 31.6 mV full scale. The gain of the meter is adjusted by potentiometer R157.

2-16. GENERATOR

2-17. GENERAL DESCRIPTION

The generator provides a pure sine-wave oscillator signal for testing from 10 Hz to 110 kHz. The generator output is direct-coupled, balanced, and floating with respect to chassis ground. The output impedance can be set to either 150 ohms or 600 ohms (except for levels greater than +21 dBm), and discrete calibrated levels in 0.1 dB steps can be selected from +27.0 dBm to -90.9 dBm (decibels relative to 1 milliwatt into 600 ohms) into 150-ohm or 600-ohm loads (17.32 V rms maximum). The level across any load used can be directly measured within the instrument. An indicating OFF switch disables the generator for convenient signal-to-noise ratio (SNR) measurements.

The oscillator is basically a Wein bridge type with a unique ultra-low distortion amplitude control circuit. This control circuit provides (1) wide frequency range (2) fast settling (3) flat frequency response and (4) ultra-low distortion. No one of these characteristics is sacrificed in order to achieve an improvement in the others.

The oscillator has two operating modes - Fast Response and Low Distortion. When Fast Response is selected, the oscillator amplitude settles quickly after a frequency change; when Low Distortion is chosen, the oscillator settling time to .002% distortion is less than 5 seconds. Built-in control circuitry automatically guides the oscillator through these modes whenever there's disturbance to the amplitude, for example, a change of frequency setting.

2-18. OSCILLATOR CIRCUIT

The basic Wein bridge oscillator consists of a reactive positive feedback network and a resistive negative feedback network, both of which are tied to the output of oscillator amplifier U1. The positive feedback network feeds back to the positive terminal of the amplifier and the negative feedback network is coupled to the negative terminal of the amplifier. Frequency of oscillation is determined in the positive feedback network by the relationship:

$$f = \frac{1}{2 \pi RC}$$

Where front panel Multiplier switches change a set of capacitors for each frequency range and the Digit switches change the resistance value. These components are located in the frequency module (See Section 4 for schematic diagram).

2-19. AMPLITUDE CONTROL

The ultra-low distortion amplitude control circuit consists of two control loops: a high-speed loop and a low-speed loop. These two loops, acting together, effectively vary the negative feedback ratio to regulate the oscillator amplitude.

Now assume that the oscillator has been set for Low Distortion operation and it is in a steady state condition. At this time, relays K1 and K2 are energized resulting in the following circuit conditions:

- a. The time constant for active RC filter U2 is now longer. This filters the sawtooth voltage driving VCR Q1 to almost a dc level, minimizing its distortion effect.
- b. The time constant for integrator U3 is now longer. This ensures that the stability of the control system is maintained.
- c. Resistor R8 is shunted in parallel with VCR Q1. This greatly limits the control range of the VCR, reducing its distortion effort.

The oscillator remains in this state until a disturbance to the oscillator amplitude occurs. At this time, the high-speed loop, in an attempt to maintain the oscillator amplitude, creates an abnormal bias level for VCR Q1. This level is sensed by level detector Q4, Q5 which in turn triggers one-shots U6A, U6B with the result that relays K1 and K2 are de-energized. This places the amplitude control system in the Fast Response mode previously discussed. The system remains in this state for $2\frac{1}{2}$ seconds.

At the end of the $2\frac{1}{2}$ second interval, relay K1 is energized. This causes the following circuit action:

- a. A shunt is placed across VCR Q1 to limit its control range.
- b. The time constant of integrator U3 is increased to maintain circuit stability.
- c. A large capacitor is allowed to charge to the steady state output value of active RC filter U2.
- d. A large capacitor is allowed to charge to the steady state output value of integrator U3.

During this intermediate state, which also lasts $2\frac{1}{2}$ seconds, the oscillator settles to a steady state condition. At the end of this interval, relay K2 is energized. This causes the following circuit action:

- a. The precharged capacitor is connected across RC filter U2.
- b. The precharged capacitor is connected across the integrator U3.

Thus after 5 seconds, the control system is back in the ultra-low distortion mode with relays K1 and K2 energized.

The high-speed loop, composed of the following major components, stabilizes the oscillator from cycle to cycle.

- a. Peak Detector Q2, Q3.
- b. Active RC filter U2 and associated RC element.
- c. Voltage-controlled resistor (VCR) Q1.

The low-speed loop, consisting of the following major components, monitors the bias applied to the VCR and ensures that the bias is always at an optimum value for low distortion.

- a. Comparator R17, R18 (these components are also input resistors for integrator U3).
- b. Integrator U3 and associated integrating capacitor.
- c. Photocoupler U7.

In the following circuit description, assume that the oscillator has been set for Fast Response operation. In this mode relays K1 and K2 are de-energized, resulting in the following circuit conditions:

- a. The time constant for active RC filter U2 is relatively short.
- b. The time constant for integrator U3 is relatively short.
- c. A high value of resistance is connected in parallel with the VCR section of the negative feedback loop. This allows the VCR to have a wide control range.

In operation, when power is first applied to the unit, there is no input from the oscillator. This causes the output of RC filter U2 to be zero and VCR Q1 to be at its lowest resistance. At the same time, the output of integrator U3 is also zero, which cuts off the drive to the light source in U7. This causes the photoresistor to have a very high resistance. These conditions result in a very low negative feedback ratio in the oscillator, causing it to start immediately after power is applied.

When the oscillator amplitude passes a reference voltage (voltage V2 across R15) at peak detector Q2, Q3, the detector produces an output current which starts to charge up RC filter U2. This in turn creates a large bias voltage (V1) to the VCR which increases its resistance. This tends to lower the amplitude of the oscillator. At the same time, comparator R17, R18 detects that voltage V1 is increasing, and when it becomes greater than its reference voltage (V3), the comparator produces a current which drives integrator U3 to turn on the light source in U7. The photoresistor responds by decreasing its resistance, tending to further dampen the amplitude of the oscillator. This action continues until (1) the oscillator amplitude equals the reference voltage (V2) and (2) the VCR bias voltage (V1) equals the reference voltage (V3).

After the oscillator has reached a steady state condition, the circuit continues to operate as follows: Any time the oscillator amplitude is lower than the reference voltage (V2), the ac peak detector Q2, Q3 reduces drive to the RC filter and VCR. This in turn causes the VCR to decrease its resistance, bringing the oscillator amplitude back to the reference level (V2). If the oscillator amplitude is higher than the reference, a reverse action increases the VCR resistance. This operation occurs once per cycle and is performed by the high-speed loop.

The bias (V1) on the VCR is constantly monitored by comparator R17, R18 against reference voltage V3. Any difference in voltage level results in a current of corresponding polarity. This current is integrated constantly by integrator U3. Over a given period of time, if there is an average net increase of VCR bias, there will be an increase of drive to the light source of U7. (The opposite is true for a net decrease of VCR bias). This increase in drive to the light source will result in a decrease of resistance in photoresistor U7. When this occurs, the VCR is no longer required to have such a high resistance and hence high bias voltage V1. Therefore, the bias voltage (V1) for the VCR will gradually return to its predetermined value, the reference voltage V3. This action which provides a constant optimum bias for the VCR, is performed by the low-speed loop.

2-20. ATTENUATOR

The principle components of the attenuator are as listed below:

- * 1 dB-per-step attenuator
- * 0.1 dB-per-step attenuator
- * Vernier attenuator
- * 10 dB-per-step attenuator
- * Generator Off switch
- * Generator Impedance Select switch

The 1 dB-per-step attenuator, the 0.1 dB-per-step attenuator, and the vernier attenuator are connected between the output of the low-distortion oscillator and the input of the balanced amplifier. Each attenuator consists of a single-ended section.

The 1 dB-per-step attenuator is a voltage divider with constant output impedance of 665 ohms. This constant output impedance is then used as a source for the vernier and the 0.1 dB-per-step attenuator. The 1 dB-per-step attenuator provides a total attenuation range of 9 dB.

The vernier attenuator operates over the upper 2-dB range of the oscillator output. Potentiometer R12 is used to adjust the range of the front panel vernier control R10.

The vernier attenuator is followed by a single section of the generator OFF switch. In the Off position, the switch removes the drive to the 0.1 dB-per-step attenuator and the balanced amplifier.

The 0.1 dB attenuator is a series-resistance string. It provides a total attenuation range of 0.9 dB to the input of the balanced amplifier.

Between the balanced amplifier and the balanced attenuator are two additional poles of the generator OFF switch. In the OFF position, the switch provides a short to circuit common as the drive to the balanced attenuator. These two sections of the switch in combination with the section between the vernier and the 0.1 dB-per-step attenuators result in a very low residual output signal from the generator when in the OFF position.

The 10 dB-per-step attenuator is balanced and is located electrically between the output of the generator off switch and the generator output terminals on the front panel of the instrument. The attenuator is made up of six discrete sections. The first is a 6-dB matching section which provides a 150-ohm balanced output impedance from the amplifier in all positions except the 26 dBm step position, where the output impedance of the amplifier is two ohms or less.

The attenuator operates as a 150-ohm balanced attenuator from the 6 dB section source with the remaining five sections coded as the attenuator schematic.

The output from the attenuator is connected to the SOURCE IMPEDANCE select switch. With the switch in the 150-ohm position it provides a straight through connection to the balanced output terminals to provide a 150-ohm source impedance. In the 600-ohm position, it switches in two 225-ohm resistors, one on either side of the line for a balanced 600-ohm source impedance at the output terminals.

The output line (no. 4) from the balanced attenuator is used to provide a signal in the +26 dBm position only to the output terminals of the SOURCE IMPEDANCE select switch so that the 225-ohm resistors, if selected, are bypassed.

The circuit common is brought out to the center tap (CT) terminal. A ground (GND) terminal which goes to the chassis through a sensitive fuse is also provided to the front panel at the generator output. This ground line is bypassed by a one microfarad capacitor and a 500 picofarad capacitor for electromagnetic interference protection of the instrument from outside sources.

2-21. BALANCED AMPLIFIER

The balanced amplifier is comprised of two separate amplifiers whose outputs are combined to deliver a balanced signal. One amplifier is non-inverting and the other is inverting.

Each amplifier consists of an operational amplifier and a current booster. The components of the non-inverting amplifier include operational amplifier U1 and current booster Q1 through Q4; the inverting amplifier is made up of U2 and current booster Q5 through Q8.

The current booster of each amplifier is capable of driving loads down to 75 ohms so that the combined total of the two amplifiers is capable of driving loads down to 150 ohms. For loads less than these impedances, internal protection circuitry limits the peak current in the current booster stages of each amplifier, preventing overheating of the output transistors and stress on the power supplies.

Potentiometer R12 in the non-inverting amplifier feedback loop provides adjustment for balance of the two amplifiers.

Overload protection circuits in each of the two amplifiers consists of two separate sections. First, diodes CR7, CR8 (CR15, CR16) prevent excessive output current through transistors Q2, Q4 (Q6, Q8) by limiting the voltage drop across the collector resistors R5, R9 (R18, R22). Second, diode pairs CR1, CR3 and CR2, CR4, (CR9, CR11, and CR12, CR14) limit the reverse base-to-emitter voltage across transistors Q2, Q4, (Q6, Q8). Inductor and resistor pair L1, R27, (L2, R28) maintains amplifier stability with reactive loads.

Zener diodes CR17, CR18 (CR19, CR20) prevent the peak-to-peak voltage across either half of the amplifier to the common of the amplifier circuits from rising above approximately 15 volts. The sensitive fuse is used to cut off excessive current of long duration through the zeners. The resistor in series with the fuse is used to protect the fuse from accidental blow-out by a high generator output level.

2-22. POWER SUPPLIES

2-23. GENERAL DESCRIPTION

There are two separate power supplies in the Model 1710A -- one provides +15 and -15 Vdc to the amplifier section, and the other +17 and -17 Vdc to the generator section. All supplies feature current foldback and current limiting.

2-24. INPUT CIRCUIT

Main power is coupled to the primary of transformer T1 via POWER switch S3, 115/230 Vac select switch S5, and fuse F1. Transformer T1 steps the main voltage down to the appropriate level for the individual power supply circuits.

2-25. +15.Vdc SUPPLY

Full wave rectifier CR601-604 and filter capacitor C601, connected to a secondary winding on T1, produce an unregulated output of approximately +25 Vdc. The regulation circuit includes pass element Q601, and integrated circuit regulator U601. Potentiometer R603 allows the output to be set to exactly +15 Vdc.

2-26. -15 Vdc SUPPLY

The -15 Vdc supply is similar to the +15 Vdc supply described above except that the outputs are reversed, resulting in a negative potential with respect to power supply ground.

2-27. +17 Vdc SUPPLY

Rectifier CR603, CR604 and filter capacitor C601, connected to a center-tapped secondary winding on T1 produce an unregulated output of approximately +26 Vdc. The regulation circuit includes pass element Q601 and integrated circuit regulator U601. Potentiometer R603 allows the output to be set to +17 Vdc.

2-28. -17 Vdc SUPPLY

The -17 Vdc supply is similar to the +17 Vdc supply described above except that the outputs are reversed with respect to power supply ground (generator common).

2-29. FLOATING GROUND SYSTEM

The complete generator is isolated from chassis and ac line ground through separate sheet metal enclosures within the main chassis and a system of shields in the power transformer. The total capacitance of the shielding of the generator system to the chassis amounts to approximately 600 picofarads. This allows full floating and/or unbalanced grounding of the generator without adverse effects of injected current from either the ac power line or internal signal generators.

2-30. ELECTROMAGNETIC INTERFERENCE CONSIDERATIONS

The analyzer is protected against external radio frequency interference sources by the following:

- a. AC line filtering through an integral shielded line filter.
- b. A complete chassis system using conductive joints between all chassis elements and complete metallic covering of the analyzer.
- c. A pi-section RC filter on the input to the analyzer at the input terminals.
- d. Capacitors across the generator grounding line to the generator ground fuse on the rear panel.

SECTION III
MAINTENANCE

3-1. INTRODUCTION

This section provides performance checks, adjustment and calibration procedures, troubleshooting techniques, and repair instructions for the Model 1710A. The section is divided into four parts. Part 1 is a test of basic operation and can be used to check general system operation and as an aid in troubleshooting. Part 2 is a complete system check and can be used for a more detailed check of individual portions of the system. Part 3 provides adjustment and calibration procedures. Part 4 supplies information on repair and replacement of parts and modules.

PART 1

3-2. PERFORMANCE CHECK

CAUTION

Due to the ultra-low distortion characteristics of the Model 1710A, only test equipment with the specifications described in table 3-2 is capable of making the distortion measurements called for in this check. Use of test equipment with equal or higher residual distortion to measure, for example, the characteristics of the low distortion oscillator, will result in erroneous readings due to:

- a. Residual distortion of measuring equipment,
- b. Reinforcement or cancellation effect of distortion products.

NOTE

1. Before beginning the test, ensure that all external equipment is completely disconnected from the Model 1710A.

2. This test measures the overall distortion of the system, with distortion from both the generator and the distortion analyzer contributing to the result. To measure the distortion of the analyzer, an extremely pure source, with a distortion of .0002 percent is required.

- a. Place ANALYZER SELECT pushbutton in GENERATOR OUTPUT position.
- b. Set Model 1710A controls as follows:

INPUT switch -----	3V
ADJUST control -----	CAL
GENERATOR LEVEL controls -----	+4 dBm, VERNIER centered
GENERATOR OFF switch -----	out
FAST RESPONSE/LOW DISTORTION switch --	LOW DISTORTION
FREQUENCY pushbuttons -----	X10 } 1000 Hz
	100 }
FILTER pushbuttons -----	NOISE, 80 kHz on
POWER switch -----	ON

- c. Press SET LEVEL pushbutton and rotate ADJUST control until meter pointer is over 1.0 mark.
- d. Press THD pushbutton and set RATIO switch to .01 range. Check that distortion reading is less than .004%.

- e. Select following oscillator frequencies and check that distortion reading for each is less than the percentage given.

<u>Multiplier</u>	<u>Digit</u>	<u>Frequency</u>	<u>Distortion (Percent)</u>
X10	10	100 Hz	.004
X1	10	10 Hz	.0045
X1	100	100 Hz	.004
X100	100	10 Hz	.004
X100	10	1 Hz	.004
X1000	10	10 Hz	.004

- f. Set RATIO switch to .03 range and change oscillator frequency to 100 kHz (x1000 and 100 pushbuttons).
- g. Release NOISE FILTER pushbutton. Check that distortion reading is less than .35

3-3. TROUBLESHOOTING

Check the 3AG 1-ampere LINE and 1/32-ampere GEN fuses located on the rear panel of the instrument.

Before attempting to troubleshoot the Model 1710A, ensure that the fault is with the Model 1710A and not caused by the test setup or associated equipment. The performance check (Paragraph 3-2) enables this to be determined without having to remove the covers from the Model 1710A.

If abnormal condition is observed during the Performance Check, Table 3-1 will suggest remedies. However, before proceeding with detailed troubleshooting, note the following suggestions:

- a. A good understanding of the principles of operation of the Model 1710A will assist the troubleshooter and it is recommended that the reader be familiar with the contents of Section II of this manual.
- b. Any suspected malfunction should first be tested with the Performance Check. This need not be carried out in its entirety ---- only the portion applicable to the suspected malfunction need be performed.
- c. Verify proper power supply operation by measuring the +15 Vdc, -15 Vdc, +17 Vdc, and -17 Vdc voltages. Check also that the +12, -6, and -8 Vdc supplies which operate the null control circuits on the analyzer board.
- d. Many measurement problems or bad readings can be related to incorrect grounding. Refer to Paragraph 1-13 for correct grounding instructions.
- e. The differential input circuitry of the Model 1710A requires a return to circuit common. Check the input cabling for proper connections.
- f. Attempt to isolate the malfunction to either the generator or the distortion analyzer. After this, try to isolate the fault to a circuit block within the suspected unit.
- g. Determine component failure within the analyzer by operating the Model 1710A without an input signal and then comparing dc levels with those marked on the schematic.
- h. Since the instrument contains a number of identical components mounted in plug-in sockets, it is permissible to switch these units in order to isolate a malfunction. However, known good components must always be returned to their original locations.
- i. Phase detector U303 in the tuning indicator need not be in position for proper notch filter operation. This component can therefore be used to isolate a malfunction in the null control circuits. But be sure to return the original I.C. to U303 when done.
- j. Abnormally large potentials (more than ± 15 mV) measured between the + and - input terminals on operational amplifiers generally indicate a defective amplifier.
- k. When a malfunction occurs try first to find out if the trouble relates to any particular pushbutton. If it does, it may be possible to cure the problem by depressing and releasing the defective button several times.

3-4. SYMPTOM/CAUSE TABLE

Table 3-1 contains symptoms of Model 1710A malfunctions and provides diagnostic tests for the location of these faults. Before beginning detailed troubleshooting, the reader is advised to study notes a. through k. in Paragraph 3-3.

Following the replacement of a defective component, refer to Paragraph 3-37 for instructions regarding any necessary calibration and/or adjustment procedures.

3-5. TEST EQUIPMENT

Recommended test equipment for performance checking and troubleshooting is listed in Table 3-2. Test instruments other than those described can be used provided their specifications equal or exceed those listed.

3-6. INTRODUCTION

The following is a complete system check for the Model 1710A. The check can be used for incoming inspection, verifying system performance, and the individual tests can be used as an aid to troubleshooting.

Before beginning the check, ensure that all external equipment is completely disconnected from the Model 1710A, and that none of the fuses described in paragraph 3-3 are blown. If the required test equipment for an individual test is not available, make a gross operational check and then proceed to the next test.

3-7. CIRCUIT COMMON ISOLATION CHECK

- a. Set POWER switch to OFF.
- b. Measure resistance between GENERATOR OUTPUT GND and CT terminals. Check that reading is greater than 10 megaohms.
- c. Set POWER to ON.

3-8. FREQUENCY AND LEVEL CHECK

- a. Set Model 1710A controls as follows:

GENERATOR LEVEL controls -----	+6 dBm, VERNIER centered
FAST RESPONSE/LOW DISTORTION switch -----	FAST RESPONSE
FREQUENCY pushbuttons -----	X10 } = 1 kHz
	100 }
OSCΔF control -----	centered
GENERATOR OFF switch -----	out

NOTE

Do not load output or connect GENERATOR OUTPUT GND terminal to any other output terminal.

- b. Connect GENERATOR OUTPUT BALANCED terminals to frequency counter and wideband ac voltmeter. Measure amplitude of output. Check that it can be adjusted to 3.08 V with the GENERATOR LEVEL VERNIER control near the center of its range.

NOTE

The Model 1710A can be used to measure the ac voltage. If this is done, the drop in response at 10 Hz is caused by the characteristics of the voltmeter and not the oscillator.

- c. Select the following oscillator frequencies and check that (1) frequency is $\cdot 2$ of set value and (2) frequency response is flat within 0.2 dB.

TABLE 3-1. MODEL 1710A SYMPTOM/CAUSE TABLE.

SYMPTOM	POSSIBLE CAUSE	DIAGNOSTIC TEST
Generator continually cycles between Fast Response and Low Distortion	<ul style="list-style-type: none"> a. R7 out of adjustment b. Oscillator amplifier U1. c. Dual timer U6. d. Photocoupler U7. e. VCR Q7. 	<ul style="list-style-type: none"> a. Carry out oscillator integrator change adjustment (See paragraph 3-25) b. Replace U1. c. Replace U6. d. Replace U7. e. Replace Q7.
Generator has no output.	<ul style="list-style-type: none"> a. GENERATOR OFF switch depressed b. Generator power supply failure. c. Oscillator amplifier U1. d. Balanced amplifier output shorted. e. Output attenuator open. 	<ul style="list-style-type: none"> a. Check position of switch b. Check +17 and -17 Vdc supply voltages. c. Replace U1. d. Check for shorts between output lines, including 10 dB attenuator. e. Check output continuity on affected ranges.
Generator has unstable distortion readings.	<ul style="list-style-type: none"> a. Oscillator amplifier U1. b. Photocoupler U7. c. VCR Q1. 	<ul style="list-style-type: none"> a. Replace U1. b. Replace U7. c. Replace Q1.
Generator produces clipped waveforms.	<ul style="list-style-type: none"> a. Balanced amplifier overload on +26 dBm. b. Balance amplifier protection CR1 thru CR4, CR7 thru CR12, CR15, CR16. c. Oscillator amplifier U1. d. RC filter amplifier U2. 	<ul style="list-style-type: none"> a. Check that load \geq 150 w total. b. Check diodes for shorts. c. Replace U1. d. Replace U2.
Generator output 6 dB low on all attenuator steps.	<ul style="list-style-type: none"> a. Half of balanced amplifier inoperative. b. Balanced amplifier short. 	<ul style="list-style-type: none"> a. Check output from each line to CT separately. b. Check for short from either output line to common before and in 10 dB attenuator.
Generator has no output on some frequencies and output on others	<ul style="list-style-type: none"> a. Bad contact in pushbutton switch. 	<ul style="list-style-type: none"> a. Refer to troubleshooting paragraph 3-3 k.
Generator has hum in output.	<ul style="list-style-type: none"> a. Improper ground connections 	<ul style="list-style-type: none"> a. Check that ground and connections are in compliance with paragraph 1-13.
High distortion under all conditions (not nulling)	<ul style="list-style-type: none"> a. Amplifier null circuit (U302, U310, U311, U312) b. Phase null circuit (U306, U307, U308, U309) c. Notch filter (U201, U202, U203, U301) 	<ul style="list-style-type: none"> a. Check dc voltages on null circuit without input signal. b. Check dc voltages on null circuit without input signal. c. Open feedback loop by lifting up one end of R203. Check dc voltages on notch filter circuit without input signal.

TABLE 3-1 (Continued)

SYMPTOM	POSSIBLE CAUSE	DIAGNOSTIC TEST
	d. Photocoupler U205. e. Photocoupler U206. f. Leaky zener diode CR304 or CR305.	d. Replace U205. e. Replace U206. f. Disconnect zener from circuit while operating in distortion mode.
Distortion reading contains excessive hum.	a. Missing ground return for Model 1710A differential front end.	a. Check that connections are in compliance with paragraph 1-13.
Analyzer had unstable distortion readings.	a. Photocoupler U205 or U206.	a. Make certain the symptom is from the analyzer and not the oscillator. Replace U205 or U206.
Nulling becomes excessively slow.	a. Oscillator frequency drifted. b. Photocoupler U205 or U206 causing higher integrator voltage.	a. Check frequency, with counter. b. Check dc voltage at TP8 with respect to TP7. If greater than 6 Vdc, adjust R359. If unable to adjust below 6 Vdc, replace U206.
Not nulling on some frequencies	a. Bad contact in pushbutton switch.	a. Refer to troubleshooting paragraph 3-3.
One of notch frequency indicators stays on during measurement on all frequencies.	a. R312 out of adjustment b. Tuning indicator circuit (U303, U304, U305) c. Phase detector U303.	a. Carry out test described in paragraph 3-35. b. Check dc voltage on circuit without input. c. Replace U303.
One notch frequency indicator stays on during measurement on some frequencies.	a. Oscillator frequency drifted b. R312 out of adjustment range c. Range capacitor(s) or digit resistor(s) drifted out of tolerance in analyzer section	a. Check oscillator frequency b. Carry out test described in paragraph 3-35. c. Unsolder range capacitor from pc board to measure value. Check suspected resistor(s) by activating proper pushbutton(s) and measure at analyzer pc board.

TABLE 3-2. REQUIRED TEST EQUIPMENT

TYPE	REQUIRED CHARACTERISTICS	USE	RECOMMENDED MODEL
AC Calibrator	Voltages: .3162 mV, 1.000 mV, 3.162 V rms Accuracy: $\pm .1$ at 1 kHz	Adjustment and Calibration	Optimization Model AC-125 or Fluke Model 5200A (*See alternate method described below.)
Digital Multi-Meter	DC Voltage Range: 200 mV to 200 V $\pm .1\%$ AC Voltage Range: 200 mV to 200 V $\pm .5\%$ Resistance Range: 200 ohms to 20 M ohms $\pm .2\%$	Adjustment and Calibration Troubleshooting	Fluke Model 8000A
Frequency Counter	Frequency Range: 10 Hz to 100 kHz Period Measurements: 10 Hz to 1 kHz Accuracy: $\pm .1\%$	Adjustment and Calibration Troubleshooting	Fluke Model 1900A
Oscilloscope	Bandwidth: DC to 10 MHz Vertical: Dual Channel	Adjustment and Calibration Troubleshooting	Hewlett-Packard Model 1220A or Philips Model PM3232
Oscillator and THD Analyzer	Frequency Range: 10 Hz to 110 kHz Residual Distortion: .002%, 10 Hz to 10 kHz	Troubleshooting	Sound Technology Model 1700A or Model 1710A
Attenuator	150 or 600 ohms, balanced dc to >100 kHz; +30 dBm input; 0 to 100 dB, 10 dB steps. Error at any step <.05 dB.	Performance Checking	Hewlett-Packard Model 4436A**
AC Voltmeter	100 Hz to >100 kHz, flat to <.05 dB 100 μ V to 30 V F.S. Linear dB scale Attenuator error <.05 dB Scale error <.01 dB over upper 11 dB	Performance Checking Troubleshooting	Hewlett-Packard Model 400F**

* To produce fairly accurate AC voltages: For 3.162 V rms -- Monitor oscillator output with Digital Multi-meter
For 1.000 mV rms - Set 1710A under test to 100 V range and set generator output for a 31.6 mV rms output with Digital Multi-meter.
For .3162 mV rms - Same as above except set 1710A under test to 300 V range.

** The attenuator and AC voltmeter are used to check performance of the Model 1710A generator level controls. For this purpose the published specifications of the recommended models are inadequate and individual units will require further checking and/or calibration to the stated accuracy before they can be used.

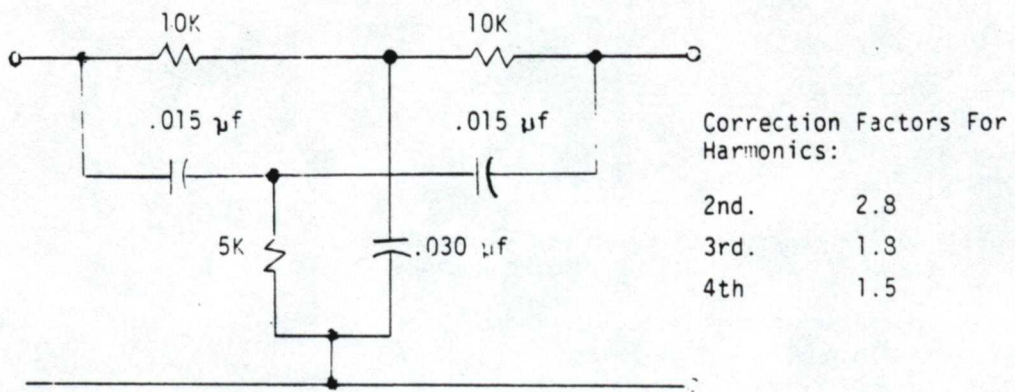

NOTE: All resistors are metal-film type, + 1% tolerance
 All capacitors are polystyrene type, ± 1% tolerance

FIG. 3-1

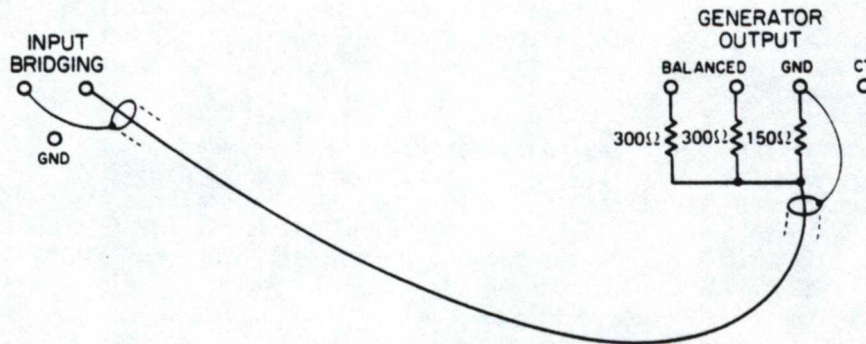

Figure 3-2. Balanced Check Test Setup.

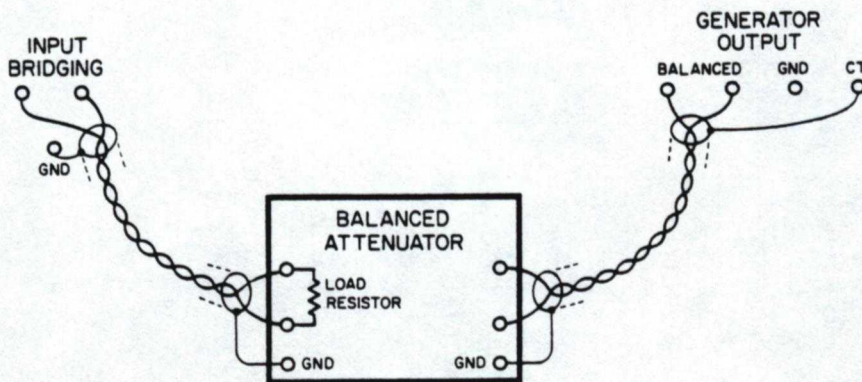

Figure 3-3. Balanced Load Test Setup.

Multiplier	Digit*	Frequency	
X10	10	100 Hz	
X1	10	10 Hz	
X1	100	100 Hz	*Set remaining digits to 0-
X100	100	10 kHz	
X100	10	1 kHz	
X1000	10	10 kHz	

3-9. DISTORTION TEST

- a. Set Model 1710A controls as described in Paragraph 3-8a, but set FAST RESPONSE/LOW DISTORTION switch to LOW DISTORTION and set ADJUST control to CAL.
- b. Measure distortion of oscillator at frequencies listed in Paragraph 3-8. Check that measurements are within specifications listed in Model 1710A data sheet.

NOTE

The measurement technique for making oscillator distortion measurements (and the accuracy of the reading) depends on the type of test equipment available to the user. In general, this equipment will fall into the following three categories listed below, in order of measurement accuracy:

1. The Model 1710A. In the absence of a wave analyzer, the Model 1710A can be used to make a rough check of the oscillator's distortion. Carry out the Distortion Test described in Paragraph 3-9.
2. Wave analyzer with a residual distortion of less than -60 dB. Set the Model 1710A to the 3 V range and adjust the GENERATOR LEVEL controls for a set level mark of -8 dB. Then use the wave analyzer, observing the signal from the INPUT MONITOR jack of the Model 1710A to sort out the harmonic distortion products of the oscillator. This measurement is, in general, accurate to approximately .0005 percent.
3. Wave analyzer with a residual distortion of less than -80 dB. Set the oscillator output as described in 2 above. Connect a twin-T filter, which must attenuate the fundamental by at least 40 dB, ahead of the wave analyzer. Then use the wave analyzer, observing the signal from the INPUT MONITOR jack of the Model 1710A, to sort out the harmonic distortion products. This method is, in general, accurate to .0001 percent or 1 ppm. A suitable twin-T network for 1.06 kHz is shown in Figure 3-1.

NOTE

To obtain the rms THD level from the measured data of 2 and 3 above, square each harmonic amplitude value, sum these squared values, and take the square root of that sum.

3-10. BALANCE CHECK

- a. Set Model 1710A controls as follows:

SET LEVEL pushbutton	-----	in	
FILTER pushbuttons	-----	out	
FREQUENCY pushbuttons	-----	X1000	} = 20 kHz
		20	
INPUT switch	-----	10 V	
ADJUST control	-----	CAL	
ANALYZER SELECT switch	-----	GENERATOR OUTPUT	
FAST RESPONSE/LOW DISTORTION switch	-----	LOW DISTORTION	
GENERATOR LEVEL controls	-----	+20 dBm, VERNIER centered	
GENERATOR OFF switch	-----	out	
SOURCE IMPEDANCE switch	-----	600 Ω	

- b. Connect a 600-ohm, 1-watt center-tapped load to GENERATOR OUTPUT terminals as shown in Figure 3-2. The two 300-ohm sections must be matched to each other within .005 percent (i.e., each must fall in the range 299.98 to 300.02 ohms) to give the required accuracy in the following measurement.
- c. Connect a cable from analyzer INPUT terminals to a 150-ohm resistor, as shown in Figure 3-2.

- d. Adjust GENERATOR LEVEL VERNIER control for an exact 0-dB reading on meter.
- e. Set ANALYZER SELECT SWITCH to INPUT position.
- f. Press dB VOLTS pushbutton and rotate RATIO switch for a reading between -10 dB and 0 dB scale marks (no greater than 0 dB) if possible.
- g. Check that RATIO switch setting is -70 dB or -80 dB.
- h. Set FREQUENCY pushbuttons to X1000, 100 for 100 kHz operation.
- i. Press SET LEVEL pushbutton.
- j. Set ANALYZER SELECT switch to GENERATOR OUTPUT position.
- k. Repeat steps d, e, and f.
- l. Check that RATIO switch setting is less than -50 dB.

3-11. VERNIER LEVEL CONTROL RANGE CHECK

- a. Set Model 1710A controls as follows:

SET LEVEL pushbutton -----	in
FILTER pushbuttons -----	out
FREQUENCY pushbuttons -----	X10 } = 1 kHz
	100 }
INPUT switch -----	30 V
ANALYZER SELECT switch -----	GENERATOR OUTPUT
FAST RESPONSE/LOW DISTORTION switch ----	FAST RESPONSE
GENERATOR LEVEL controls -----	+20 dBm, VERNIER CW limit
GENERATOR OFF switch -----	out
SOURCE IMPEDANCE switch -----	600 Ω

NOTE

Do not make any external connections to the GENERATOR OUTPUT or ANALYZER INPUT terminals.

- b. Rotate ADJUST control for a meter reading of exactly +1 dB.
- c. Rotate GENERATOR LEVEL VERNIER control to its CCW limit and check that meter reading decreases by 2.0 to 2.2 dB.
- d. Repeat steps a through c, setting the FREQUENCY pushbuttons for X1000, 100 = 100 kHz.

3-12. 1 AND 0.1 dB-PER-STEP LEVEL CONTROLS

- a. Set Model 1710A controls as follows:

VOLTS POWER pushbutton -----	in
FILTER pushbuttons -----	out
FREQUENCY pushbuttons -----	X1000 } = 100 kHz
	100 }
INPUT switch -----	10 V
ANALYZER SELECT switch -----	GENERATOR OUTPUT
FAST RESPONSE/LOW DISTORTION switch ----	LOW DISTORTION
GENERATOR LEVEL controls -----	+20 dBm
GENERATOR OFF switch -----	out
SOURCE IMPEDANCE switch -----	600 Ω

- b. Connect a 600-ohm, ½-watt balanced and floating load across GENERATOR OUTPUT BALANCED terminals, and short GENERATOR OUTPUT GND and CT terminals together.
- c. Connect an AC voltmeter as specified in Table 3-2, to INPUT MONITOR jack. Set voltmeter range to 0.3 V full scale.

- d. Rotate GENERATOR LEVEL VERNIER control for a reading on ac voltmeter of +0.20 dB exactly.
- e. Step 1 dB-per-step GENERATOR LEVEL switch through its range to -9 dB while checking that ac voltmeter indicates each step with an absolute level tolerance of 0.05 dB.
- f. Return 1 dB-per-step GENERATOR LEVEL switch to 0 dB.
- g. Repeat steps d through f for 0.1 dB-per-step GENERATOR LEVEL switch.

3-13. +26 AND +20 dBm LEVEL CHECKS

- a. Set Model 1710A controls as detailed in Paragraph 3-12.
- b. Connect a 600-ohm, 0.1%, 1/2-watt balanced and floating load across GENERATOR OUTPUT BALANCED terminals and short GENERATOR OUTPUT GND and CT terminals together.
- c. Connect an ac voltmeter as specified in Table 3-2 to INPUT MONITOR jack. Set voltmeter range to 0.3 V full-scale.
- d. Set 1 dB-per-step GENERATOR LEVEL switch of Model 1710A to -6 dB and adjust GENERATOR LEVEL VERNIER control for a reading on ac voltmeter of -5.80 dB exactly.
- e. Set the 10 dB-per-step GENERATOR LEVEL switch to +26 dBm and check that ac voltmeter reads +0.20 dB within 0.05 dB.

3-14. 10 dB-PER-STEP LEVEL CONTROL, BALANCED LOADS

- a. Set Model 1710A controls as follows:

dB VOLTS pushbutton -----	in	
FILTER PUSHBUTTONS -----	HUM in	
FREQUENCY pushbuttons -----	X1000	} = 100 kHz
	X100	
INPUT switch -----	0.3 V	
RATIO switch -----	-70 dB	
ADJUST control -----	CAL	
ANALYZER SELECT switch -----	INPUT	
FAST RESPONSE/LOW DISTORTION switch -----	LOW DISTORTION	
GENERATOR LEVEL controls -----	+20 dBm	
GENERATOR OFF switch -----	out	

- b. Connect balanced attenuator specified in Table 3-2 between GENERATOR OUTPUT BALANCED terminals and INPUT BRIDGING terminals as shown in Figure 3-3. Be sure of ground connections as shown and provision of a balanced and floating load across output of attenuator which matches attenuator impedance within 0.1%. Shielded connectors, such as the Pomona Type 1921, should be used for these connections.
- c. Set Model 1710A SOURCE IMPEDANCE switch to impedance of balanced attenuator.
- d. Set attenuation of the balanced attenuator to 100 dB and note that this gives a meter reading on the Model 1710A of approximately 78 microvolts.
- e. Connect the ac voltmeter to OUTPUT MONITOR jack and set the sensitivity to 30 millivolts full scale. Preferably, use a shielded connector at the voltmeter input.
- f. Adjust GENERATOR LEVEL VERNIER control for a meter reading on ac voltmeter of +0.50 dB exactly.
- g. Set Model 1710A 10 dB-per-step GENERATOR LEVEL switch to +10 dBm and balanced attenuator to 90 dB. Check that ac voltmeter reading is different from +0.50 dB by less than 0.10 dB.
- h. Continue to decrease Model 1710A output level in 10 dB steps to -80 dBm with corresponding decreases in attenuation of balanced attenuator, each time checking that ac voltmeter reading differs from +0.50 dB by less than 0.15 dB.

3-15. 10 dB-PER-STEP LEVEL CONTROL, UNBALANCED LOADS

- a. Set Model 1710A controls as follows:

FREQUENCY pushbuttons -----	X1000 100	} = 100 kHz
ANALYZER SELECT switch -----	INPUT	
FAST RESPONSE/LOW DISTORTION switch -----	LOW DISTORTION	
GENERATOR LEVEL controls -----	+20 dBm	
GENERATOR OFF switch -----	out	
SOURCE IMPEDANCE -----	600 Ω	

- b. Connect a 600-ohm, 0.1%, 1/2-watt balanced and floating load across GENERATOR OUTPUT BALANCED terminals and then connect ac voltmeter across load using shielded connectors such as Pomona Type 1921 or Type 1845, and appropriate shielded cable.
- c. If input of ac voltmeter is not unbalanced to ground, connect GND terminal at generator output to adjacent terminal of GENERATOR OUTPUT BALANCED terminal pair.
- d. Set ac voltmeter sensitivity to 10 V full-scale.
- e. Adjust GENERATOR LEVEL VERNIER control for a meter reading on ac voltmeter of +0.50 dB exactly.
- f. Set 10 dB-per-step GENERATOR LEVEL switch to +10 dBm and ac voltmeter sensitivity to 3 V full-scale. Check that ac voltmeter reading is different from +0.50 dB by less than 0.10 dB.
- g. Continue to decrease Model 1710A output level in 10 dB steps to -80 dBm with corresponding increase in sensitivity of ac voltmeter, each time checking that ac voltmeter reading differs from +0.50 dB by less than 0.20 dB.

3-16. dB VOLTS TEST

- a. Set Model 1710A controls as follows:

INPUT switch -----	30 V	
ADJUST control -----	CAL	
GENERATOR LEVEL controls -----	-50 dBm, VERNIER centered	
GENERATOR OFF switch -----	out	
FAST RESPONSE/LOW DISTORTION switch --	LOW DISTORTION	
SOURCE IMPEDANCE switch -----	600 Ω	
FREQUENCY pushbuttons -----	X10 100	} = 1000 Hz
RATIO switch -----	.01	
ANALYZER switch -----	GENERATOR OUTPUT	

- b. Connect 600-ohm load across GENERATOR OUTPUT BALANCED terminals.
- c. Press dB VOLTS pushbutton and adjust GENERATOR LEVEL VERNIER control for a 0 db reading on meter.
- d. Set RATIO switch to next higher range and check that signal drops by approximately 10 dB.
- e. Set GENERATOR LEVEL switches to -40 dBm and VERNIER control for a 0-dB reading. Now set RATIO switch to next higher range. Check that signal drops by approximately 10 dB.
- f. Repeat this operation until a -10 dB reading on 30% range is reached. Rotate ADJUST control for a 0 dB reading.
- g. Set RATIO switch to 100% range and check that signal drops approximately 10 dB.

3-17. VOLTS POWER TEST

- a. Set Model 1710A controls as follows:

INPUT switch -----	.1 mV
ADJUST control -----	CAL
GENERATOR LEVEL controls -----	-80 dBm, VERNIER centered
GENERATOR OFF switch -----	out
FAST RESPONSE/LOW DISTORTION switch --	FAST RESPONSE
SOURCE IMPEDANCE switch -----	600 Ω
FREQUENCY pushbuttons -----	X10 } = 1000 Hz 100 }
ANALYZER SELECT switch -----	GENERATOR OUTPUT

- b. Connect a 600-ohm load across GENERATOR OUTPUT BALANCED terminals.
- c. Press VOLTS/POWER pushbutton and adjust GENERATOR LEVEL VERNIER control until meter pointer indicates 0 dB.
- d. Set INPUT switch to next higher range and check that signal drops by approximately 10 dB.
- e. Again adjust GENERATOR LEVEL controls for a 0-dB reading and then set INPUT switch to next higher range. Check that signal again drops by approximately 10 dB.
- f. Repeat this operation until 10 volt range (+20 dBm) is reached. Now up range INPUT switch through remainder of its ranges, checking that signal drops by approximately 10 dB on each range.

3-18. FILTERS TEST

- a. Set Model 1710A controls as follows:

INPUT switch -----	3 V
ADJUST control -----	CAL
GENERATOR LEVEL controls -----	+10 dBm, VERNIER centered
GENERATOR OFF switch -----	out
FAST RESPONSE/LOW DISTORTION switch -----	LOW DISTORTION
SOURCE IMPEDANCE switch -----	600 Ω
FREQUENCY pushbuttons -----	X10 } = 400 Hz 40 }
ANALYZER SELECT switch -----	GENERATOR OUTPUT

- b. Connect a 600-ohm load across GENERATOR OUTPUT BALANCED terminals.
- c. Press dB VOLTS pushbutton and adjust GENERATOR LEVEL VERNIER control for a 0-dB meter reading.
- d. Press HUM FILTER pushbutton. Check meter for a -3 dB reading.
- e. Release HUM FILTER pushbutton.
- f. Set frequency to 80 kHz (depress X1000 and 80 pushbuttons). Press NOISE FILTER pushbutton and set 30/80 kHz switch to 80 kHz. Check that signal attenuation is 3 dB or more.
- g. Release NOISE FILTER pushbutton.
- h. Set frequency to 30 kHz (depress X1000 and 30 pushbuttons). Press NOISE FILTER pushbutton and set 30/80 kHz switch to 30 kHz. Check that signal attenuation is 3 dB or more.

3-19. RESIDUAL NOISE TEST

- a. Set Model 1710A controls as follows:

INPUT switch -----	3 V
ADJUST control -----	CAL
GENERATOR LEVEL controls -----	+12 dBm, VERNIER centered
GENERATOR OFF switch -----	out
FAST RESPONSE/LOW DISTORTION switch --	LOW DISTORTION
SOURCE IMPEDANCE switch -----	600 Ω
FREQUENCY pushbuttons -----	X10 } = 1000 Hz
	100 }
ANALYZER SELECT switch -----	GENERATOR OUTPUT
FILTER Pushbuttons -----	NOISE, 80 kHz on

- b. Connect a 600-ohm load across GENERATOR OUTPUT BALANCED terminals.
- c. Depress SET LEVEL pushbutton and adjust GENERATOR LEVEL VERNIER control until meter pointer is at 1.0 mark.
- d. Press THD pushbutton and set RATIO switch to .01 range. (This reading is noise and distortion of oscillator and analyzer.)
- e. Press SET LEVEL pushbutton and adjust GENERATOR LEVEL controls for a meter reading of -15 dB. (This greatly reduces the level of the signal input to the analyzer with the result that almost all of the distortion products are eliminated and only the residual noise of the analyzer remains.)
- f. Press THD pushbutton. Check that meter reading is less than .0025%.
- g. Place ANALYZER SELECT switch in INPUT position.
- h. Place a shorting link between INPUT BRIDGING terminals and connect to INPUT GND terminal.
- i. Press dB VOLTS pushbutton and set controls as follows (meter full-scale sensitivity is now 30 microvolts).

INPUT switch -----	.3 V
ADJUST control -----	CAL (full CCW)
RATIO switch -----	.01%

- j. Press NOISE FILTER pushbutton and set 30/80 kHz switch to 80 kHz. Check that reading is less than 8 microvolts.
- k. Release NOISE FILTER pushbutton and check that reading is less than 15 microvolts.

3-20. COMMON MODE REJECTION TEST

- a. Set ANALYZER SELECT pushbutton to GENERATOR OUTPUT and set oscillator frequency to 60 Hz (depress X1 and 60 pushbuttons).
- b. Press VOLTS POWER pushbutton and adjust GENERATOR LEVEL controls for a meter reading of 1 volt with the INPUT switch set to 1 V range.

NOTE

A load need not be used across the GENERATOR OUTPUT BALANCED terminals.

- c. Set ANALYZER SELECT switch to INPUT position and short INPUT BRIDGING terminals together.
- d. Connect input cable from GENERATOR OUTPUT, BALANCED terminals to INPUT BRIDGING and INPUT GND terminals. (In this connection, the generator signal is connected between ground and the shorted analyzer inputs, establishing a common-mode signal.)
- e. Set RATIO switch to -20 dB range and ADJUST control to CAL position.
- f. Press dB VOLTS pushbutton. Check that meter reading is -20 dB or lower.

NOTE

The distortion specifications of the analyzer are much lower than those of the generator. Therefore, if it is desired to check the specifications, a clean-up filter can be made for use between the generator and the analyzer. Information regarding such a filter will be supplied by Sound Technology upon request. The method used in the performance test section is suitable for determining proper system operation. The clean-up filter is only necessary for a detailed system analysis.

PART 3 - ADJUSTMENT AND CALIBRATION PROCEDURE

3-21. INTRODUCTION

The following is a complete adjustment and calibration procedure for the Model 1710A. The procedure should be carried out only when the Performance Check (Paragraph 3-2) indicates that adjustments are required. If the Model 1710A does not meet the test limits specified in the following steps, consult the troubleshooting data provided in Paragraph 3-3. The location of the adjustment controls for the analyzer, oscillator, balanced amplifier, attenuators, and power supplies are shown in the parts location diagrams contained in Section IV.

3-22. -17 VOLT ADJUSTMENT

- a. Connect HI terminal of digital voltmeter (DVM) to -V terminal and LO lead to GND terminal on generator power supply assembly.
- b. Adjust potentiometer R614 on generator power supply assembly for a DVM reading of $-17.000 \pm .010$ V.

NOTE

The generator power supply is located in the bottom section of the unit.

3-23. +17 VOLT ADJUSTMENT

- a. Set Model 1710A controls as follows:

GENERATOR LEVEL controls -----	+26 dBm, VERNIER fully CW
GENERATOR OFF switch -----	out
FAST RESPONSE/LOW DISTORTION switch -----	LOW DISTORTION
FREQUENCY pushbuttons -----	X10 } = 1000 Hz
	100 }
ANALYZER SELECT switch -----	INPUT

- b. Connect DVM in AC mode across GENERATOR OUTPUT BALANCED terminals. Do not connect another load or ground to these terminals or the GENERATOR OUTPUT CT terminal.
- c. Adjust potentiometer R603 on generator power supply assembly for a DVM reading of $17.3 \pm .01$ V.

3-24. OSCILLATOR PHOTOCCELL ADJUSTMENT

- a. Set Model 1710A controls as follows:

FREQUENCY pushbuttons -----	X10 } = 100 Hz
	10 }
FAST RESPONSE/LOW DISTORTION switch -----	FAST RESPONSE

- b. Connect HI lead of DVM to junction of R3 and R4; connect DVM LO lead to "0" terminal (oscillator output) on oscillator board.
- c. Adjust R5 for AC voltage reading of .20 V.

NOTE

Clockwise rotation of R5 decreases voltage, counterclockwise rotation increases voltage.

dB VOLTS pushbutton	-----	in
FILTER pushbuttons	-----	out
FREQUENCY pushbuttons	-----	X 1000 } 100 kHz
		100 }
INPUT switch	-----	1V
RATIO switch	-----	.01
ADJUST control	-----	CAL
ANALYZER SELECT switch	-----	GENERATOR OUTPUT
FAST RESPONSE/LOW DISTORTION switch	-----	LOW DISTORTION
GENERATOR LEVEL controls	-----	-80 dBm VERNIER centered
GENERATOR OFF switch	-----	out
SOURCE IMPEDANCE switch	-----	600

- b. Connect a 600-ohm balanced load across GENERATOR OUTPUT BALANCED terminals. Make no other connections to these or CT terminal.
- c. Adjust GENERATOR LEVEL VERNIER control for a meter reading of 0.850 exactly on the meter scale.
- d. Connect a short lead between GENERATOR OUTPUT GND terminal and one of the BALANCED terminals.

NOTE

In strong RF fields, significant energy may be induced into the analyzer input with this procedure, thereby making measurements difficult. Use of a shielded 600-ohm load and a short grounding lead together with observation of the signal from the OUTPUT MONITOR jack will help alleviate this problem. The operators hands and body should be kept as far as possible from the output terminals and in the following adjustments from the interior generator shields and components.

- e. Note Model 1710A meter reading deviation from 0.850.
- f. Shift short lead so that it goes between GENERATOR OUTPUT GND terminal and other BALANCED terminal.
- g. Note Model 1710A meter reading deviation from 0.850.
- h. Connect lead from GENERATOR OUTPUT GND terminal to BALANCED terminal giving greatest deviation (positive or negative) as noted in steps e. and g.
- i. Adjust potentiometer R12 on balanced amplifier board to bring meter indication within one minor scale division of 0.850. Gain access to control through cover of attenuator assembly using an eight-inch or longer plastic tuning screwdriver.
- j. Remove lead of step h from BALANCED terminal and again, if necessary adjust OSCILLATOR LEVEL VERNIER control for a meter reading of 0.850.
- k. Repeat steps d through j until reading noted in steps e and g are both between 0.850 and 0.860.
- l. Make the Balance Check of paragraph 3-10.

3-29. VERNIER ATTENUATOR RANGE

- a. Carry out steps a through d of Vernier Level Control Range check, Paragraph 3-11, noting either 1 kHz or 100 kHz as frequency which gives highest signal level with GENERATOR LEVEL VERNIER control at its CCW limit. Set Model 1710A to this frequency and with GENERATOR LEVEL VERNIER control at its CW limit, set ADJUST control again for a meter reading of +1.0 dB exactly.
- b. Rotate GENERATOR LEVEL VERNIER control to its CCW limit.
- c. Adjust potentiometer R12 above the GENERATOR LEVEL VERNIER control for a reading of exactly -1.0 dB.

- e. Monitor waveform at pin 6 of U312 with the other scope channel.
- f. Adjust R351 for minimum fundamental signal at pin 6 of U312.
- g. Now, monitor waveform at OUTPUT MONITOR jack.
- h. Adjust potentiometers R337 and R354 until Distortion output waveform contains no fundamental signal.

3-34. PHASE NULL INTEGRATOR VOLTAGE ADJUSTMENT

- a. Set Model 1710A controls as described in Paragraph 3-2, Steps a. through d.
- b. Connect DVM HI lead to TP9 and LO lead to TP6.
- c. Adjust R364 for a dc voltage reading of 2.8V*.

*The 2.8V setting is for a dark adapted photocoupler. This is a photocoupler which has been in the off state for the last 24 hours (instrument power off). It is normal for the voltage at TP6 to gradually increase with time.

If the dc voltage between TP9 and TP6 is greater than 3.0V after the instrument has been on for 24 hours or more, readjust R364 for 3.0V

3-35. TUNING INDICATOR ADJUSTMENT

- a. Set Model 1710A controls as follows:

INPUT switch	-----	3V
ADJUST control	-----	CAL (fully CCW)
RATIO switch	-----	1%
FREQUENCY pushbuttons	-----	X 10 (2nd. and 3rd. digits to zero)
GENERATOR LEVEL controls	-----	+ 6 dBm, VERNIER centered
FAST RESPONSE/LOW DISTORTION	-----	FAST RESPONSE

NOTE

Do not load the output or connect GND terminal to any other output terminal.

- b. Connect DVM LO lead to green wire connected to NOTCH FREQUENCY indicators and HI lead to junction of R320 and pin 6 of U305.
- c. Press in turn each FREQUENCY 1st digit pushbutton and observe DVM voltage readings. Record (1) digit giving most positive reading and its value and (2) digit giving most negative reading and its value.
- d. Press X1 Multiplier FREQUENCY pushbutton, and repeat procedure described in Step c.
- e. Press X100 Multiplier FREQUENCY pushbutton and repeat procedure described in Step c.
- f. Review all readings recorded and determine (1) most positive value and (2) most negative value. Add these two values together (to determine voltage range) and then divide number by 2 (to determine mid-point).
- g. Press digit previously determined to have most positive reading and adjust potentiometer R312 until DVM indicates mid-point value determined in Step f. See example below:

<u>Multiplier</u>	<u>Most Pos. Digit</u>	<u>Most Neg. Digit</u>
X 10	60, + 1.0 V	50, + .20 V
X 1	60, - .20 V	50, - .70 V
X 100	60, + .01 V	50, - .60 V

Overall most positive = X 10. 60 = + 1.0 V
 Overall most negative = X 1. 50 = - .70 V
 Range = 1.70 V, mid-point = .85 V
 Adjust X 10, 60 for + .85 V

- h. Press X 1000 Multiplier pushbutton and repeat Steps c. and f.
- i. Now press digit giving most positive value and using a non-metallic screwdriver, adjust trimmer capacitor accessible through hole in shield on right-hand side of instrument for mid-point value determined in repeat of Step f.

3-36. CALIBRATION AT 1 KHZ

- a. Set Model 1710A controls as follows:

VOLTS POWER pushbutton	-----	depressed
FILTER pushbuttons	-----	out
FREQUENCY pushbutton	-----	X 10 } = 1 kHz
		100 }
INPUT switch	-----	3 V
ADJUST control	-----	CAL (fully CCW)
RATIO switch	-----	.03%

- b. Set meter mechanical zeroing as described in paragraph 1-19.
- c. Apply an accurate 3.162 V + 0.1% or better 1 kHz signal between INPUT BRIDGING terminals (refer to table 3-2). Connect low side of test signal to right-hand INPUT BRIDGING terminal.
- d. Connect chassis of precision ac source to INPUT GND terminal on Model 1710A
- e. Adjust Meter Sensitivity potentiometer R157 for an exact full-scale reading (1.0 mark on VOLTS scale) on meter.
- f. Press SET LEVEL pushbutton. Adjust Set Level potentiometer R146 for an exact fullscale reading.
- g. Change input signal level to 1.000 mV. Press dB VOLTS pushbutton and adjust Distortion Amplifier Gain potentiometer R237 for an exact full-scale reading.
- h. Change input signal level to .3162 mV and set RATIO switch to .01%. Adjust Distortion Amplifier Gain potentiometer R239 for an exact full-scale reading.

3-37. COMPONENT REPLACEMENT - CALIBRATION AND ADJUSTMENT

Portions of the Model 1710A Adjustment and Calibration Procedure (Paragraph 3-21) and other adjustments must be completed following the replacement of certain components in the instrument. These components, and the applicable Adjustment/Calibration Procedures are as listed below:

<u>Component</u>	<u>Required Adjustment/Calibration Procedure</u>
a. Photocoupler U7 (Oscillator)	Oscillator Integrator Output Adjustment (Paragraph 3-26)
b. Voltage - controlled resistor Q1 (Oscillator)	Oscillator Integrator Voltage Change Adjustment (Paragraph 3-25)
c. Operational Amplifier U1 (Oscillator)	Oscillator X 1000 Frequency Range Adjustment (Paragraph 3-27)
d. Operational Amplifier U1, U2 (Balanced Amplifier)	Amplifier Balance (Paragraph 3-28)
e. Operational Amplifiers 2605, 2625 (Analyzer)	DC Zero Adjustment - related Adjustment (Paragraph 3-32)

- | | | |
|----|--|--|
| f. | Meter M1
(Analyzer) | Calibration at 1 kHz.
(Paragraph 3-36) |
| g. | Phase detectors
U307, U310
(Analyzer, null control) | Null Adjustment
(Paragraph 3-33) |
| h. | Phase detector
U303
(Analyzer, tuning indicator) | Tuning Indicator Adjustment
(Paragraph 3-35) |
| i. | Photocoupler U205
(Analyzer, phase null
control) | Allow 10 minutes for the photocoupler to cool off
after soldering. Phase Null Integrator Voltage
Adjustment (Paragraph 3-34). |
| j. | Photocoupler U206
(Analyzer, amplitude null
control) | Allow 10 minutes for the photocoupler to cool
off after soldering. Set controls as described
above. Connect DVM HI lead to TP8 and LO lead to
TP7. Reading is dc voltage across R359. Calculate
current through it. If necessary, select new value
for R359, such that $1.4 \pm .2V$ is developed across it.
Replace R359. |

PART 4 - REPLACEMENT AND REPAIR

3-38. SPECIAL PRECAUTIONS

The performance of the Model 1710A will be greatly degraded by contamination of the circuit-board surfaces or components. Finger marks and oil droplets are contaminants to be especially avoided. To minimize the possibility of contaminations, observe the following precautions:

- a. Do not disassemble any portion of the Model 1710A unless absolutely necessary (for example, to replace relays on oscillator board or to service frequency modules.)
- b. Avoid any unnecessary handling of the printed-circuit boards or components. Replace components from the top side of the boards only.
- c. Employ only the soldering and component replacement techniques described in Paragraphs 3-40 through 3-43.

3-39. WIRING

Lead dress within the instrument should not be altered. This is especially important with the wires running between the rotary switches and the distortion analyzer assembly. Before removing an assembly with wires attached, make a sketch showing the exact arrangement of the wires so that they may be replaced in the same manner.

3-40. SOLDERING TECHNIQUES

- a. Use a low-wattage iron with a pencil-shaped tip and allow it to reach full operating temperature before use. A fully-heated iron ensures the quick completion of soldering and minimizes the chance that the etched wiring on the printed-circuit boards will be damaged by excessive heat.
- b. Before using the soldering iron, wipe it off to remove excess solder and oxide.
- c. Use only a solder with non-corrosive non-conductive flux. Do not use acid-cored solder.
- d. Do not clean off the rosin around the soldered joint with a wire brush or metal scribe. This will destroy the high electrical resistance of the board.

3-41. COMPONENT REPLACEMENT

CAUTION

The use of Soder-Wick* (rosin-impregnated copper braid) or a similar product is highly recommended for the removal of solder during the de-soldering operation. If it is not available, and a vacuum-type de-soldering tool is employed, ensure that it is cleaned before use. This is to prevent the possibility of conductive debris being sprayed on the board during the de-soldering process.

3-42. MULTI-LEAD DEVICES

Follow the instructions given below when replacing multi-lead components on the printed-circuit boards:

- a. Cut all leads to remove device from P.C. board. The pieces of the leads that remain can then be unsoldered from the board.

CAUTION

Be sure to hold each lead with needle-nose pliers when it is unsoldered. This is to prevent the possibility of a lead dropping through a hole and shorting traces below the board.

- b. Using Solder-Wick, remove remaining solder from component holes.
- c. When replacing a device, ensure that the length of its leads match the length of the leads on the device removed. Do not push the new device too far down into board as this may cause a short to the metal deck below. The clearance between the boards and the metal deck is 1/4 inch.

3-43. POTENTIOMETERS

The small black rectangular potentiometers are attached to the printed-circuit boards by three small leads projecting from their lower surface in line with the numbers "1", "2" & "3" marked on top. To remove this type of potentiometer, proceed as follows:

- a. Carefully raise side of potentiometer opposite numbers until leads below are visible.
- b. Continue bending leads until there is sufficient clearance for tip of soldering iron.
- c. Unsolder potentiometer following instructions given in Paragraph 3-40.
- d. Install replacement component following reverse procedure.

3-44. ANALYZER POWER SUPPLY

The majority of the components on the power supply assembly may be replaced without removing the board from its location under the analyzer deck. However, if additional access is required, remove the retaining screws securing the power supply to the analyzer deck.

3-45. OSCILLATOR ACCESS

To gain access to the oscillator, proceed as follows:

- a. Remove 12 screws on top cover of instrument and carefully lift off cover.
- b. Loosen set screw in VERNIER attenuator shaft extension and separate from shaft by pulling forward through front panel.

NOTE

Knobs and shaft extension need not be removed from instrument to gain access to generator sections.

*Soder-Wick may be obtained from Solder Removal Company, Covina, CA, U.S.A.

- c. Loosen both set screws in GENERATOR OFF switch coupling. Slide coupling forward on shaft using care not to damage pushbutton indicator mechanism. Restrain pushbutton from forward movement out of front panel.
- d. Release three attenuator switch extensions by pulling extension forward against spring until extension separates from shaft. Tip extension to one side and slowly release spring pressure until knob rests against front panel.
- e. Remove two screws securing attenuator housing to left and right sides of generator housing. (The screws are located in clearance holes in center divider and right side brace.)
- f. Tip attenuator housing up and back towards rear panel.

NOTE

If floating operation of generator is necessary with attenuator in raised position, do not allow attenuator to contact rear panel.

- g. Reassemble instrument following reverse procedure.

NOTE

When reconnecting three attenuator switch shaft extensions, check front panel for proper switch indication. (Extension can be installed 180 degrees from correct position.) When switches are turned fully clockwise, indications should be: +26, 0, 0.

3-46. FREQUENCY MODULE REPAIR

The following procedure details step by step instructions for disassembly and repair of the instrument's frequency module. It is recommended that this procedure be closely followed and performed only by personnel familiar with electronic equipment disassembly/assembly techniques.

3-47. REPAIR AND REPLACEMENT

CAUTION

Certain subassemblies in the instrument are secured with hardware which includes insulating washers. Note the location of these washers when disassembling the unit and replace them in the same locations on reassembly. Failure to observe this precaution will result in improper operation of the instrument.

- a. Remove top and bottom covers (12 screws each) and place instrument on clean work surface.
- b. Refer to Paragraph 3-45 for procedure to be followed to gain access to oscillator section.
- c. Remove two screws securing top cover over frequency module switches and remove cover.
- d. If oscillator section of generator is to be removed, disconnect all external wiring and remove four mounting screws from top of low-distortion oscillator printed-circuit board. If repair of only the analyzer section of the frequency module is required, disregard this step.
- e. Loosen set screw securing coupling to OSCΔF potentiometer and pull extension shaft toward front panel.
- f. Remove four screws securing generator power supply cover to bottom side of oscillator housing and remove cover.
- g. Remove two screws securing generator housing to center divider (one screw is located above analyzer deck and one is located below deck).
- h. Rest instrument on left side.

- i. Remove two screws securing generator housing to right side brace.
- j. Move generator section toward rear panel and top of instrument as far as cables will allow. (Rotation of entire section may facilitate movement.)
- k. If oscillator section is not being removed, proceed to step 0.
- l. Remove two screws securing generator face plate to housing. (Screws are located in lower flange of faceplate.)
- m. Slide oscillator section out of housing.
- n. Replace oscillator section and reassemble instrument following reverse procedure observing notes and cautions found at the end of this section.
- o. If removal of analyzer section of frequency module is desired remove four nuts securing section to front panel. Slide assembly back for access. If complete removal is required disconnect wires from main analyzer printed-circuit board and push connector receptacles back through plastic bushings in divider noting routing for reassembly.
- p. Replace analyzer frequency module and generator module, and reassemble instrument following reverse procedure.

NOTE

1. The wires are color-coded for attachment to the numbered holes in the printed circuit board: black = 0, brown = 1, red = 2, orange = 3, yellow = 4, etc.
2. When replacing analyzer portion of frequency module, line up pushbuttons with openings in front panel.
3. When replacing generator module, test operation of all pushbutton switches prior to final tightening of the screws securing oscillator housing in instrument. Unusual stiffness of any switch indicates improper alignment of one or both modules.

3-48. REPAIR INSTRUCTIONS

CAUTION

Field repair of the frequency module is limited to replacement of defective RC components on the switch boards. Replacement of pushbutton switches is not recommended -- order a replacement switch board from the factory.

- a. Remove bus wires running between boards, using multi-lead component desoldering technique described in this section of the manual. (Paragraph 3-40)
- b. Detach board containing defective components from switch bracket and replace component.
- c. Reassemble module, replacing bus wires removed in Step a.

NOTE

1. Spacing between boards must be 25/32 inch (inside to inside dimension) to ensure proper alignment.
2. When replacing oscillator frequency module, ensure that there is a .015 inch clearance between the analyzer and oscillator pushbars, with the pushbuttons in undepressed position.
3. Boards must be perpendicular to switch mounting bracket.

SECTION IV DIAGRAMS

4-1. INTRODUCTION

This section contains the circuit diagrams necessary for the operation and maintenance of the Model 1710A. Included are schematic diagrams and component location diagrams.

4-2. SCHEMATIC DIAGRAMS

The circuitry contained within each assembly is shown in the schematic diagrams. As an aid to isolating malfunctions, the diagrams also provide typical operating voltages and wave-forms.

4-3. COMPONENT LOCATION DIAGRAMS

The component location diagrams show the physical location of parts mounted on each assembly. Each part is identified by a reference designator, similarly identified on the schematic diagrams and in the parts list.

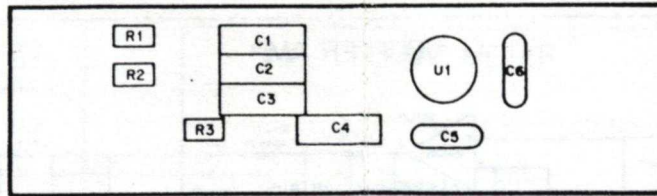

30 KHz FILTER BOARD

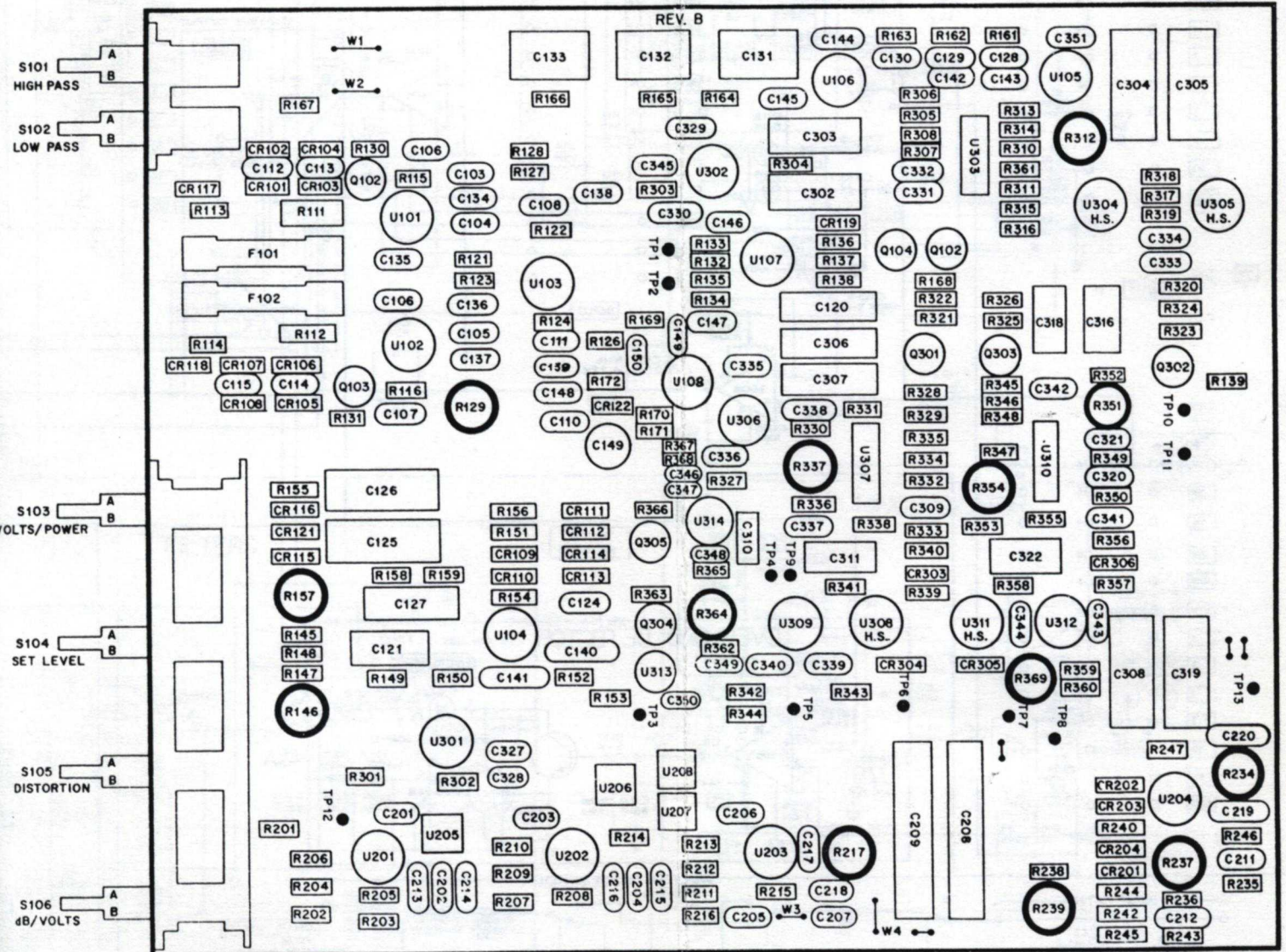
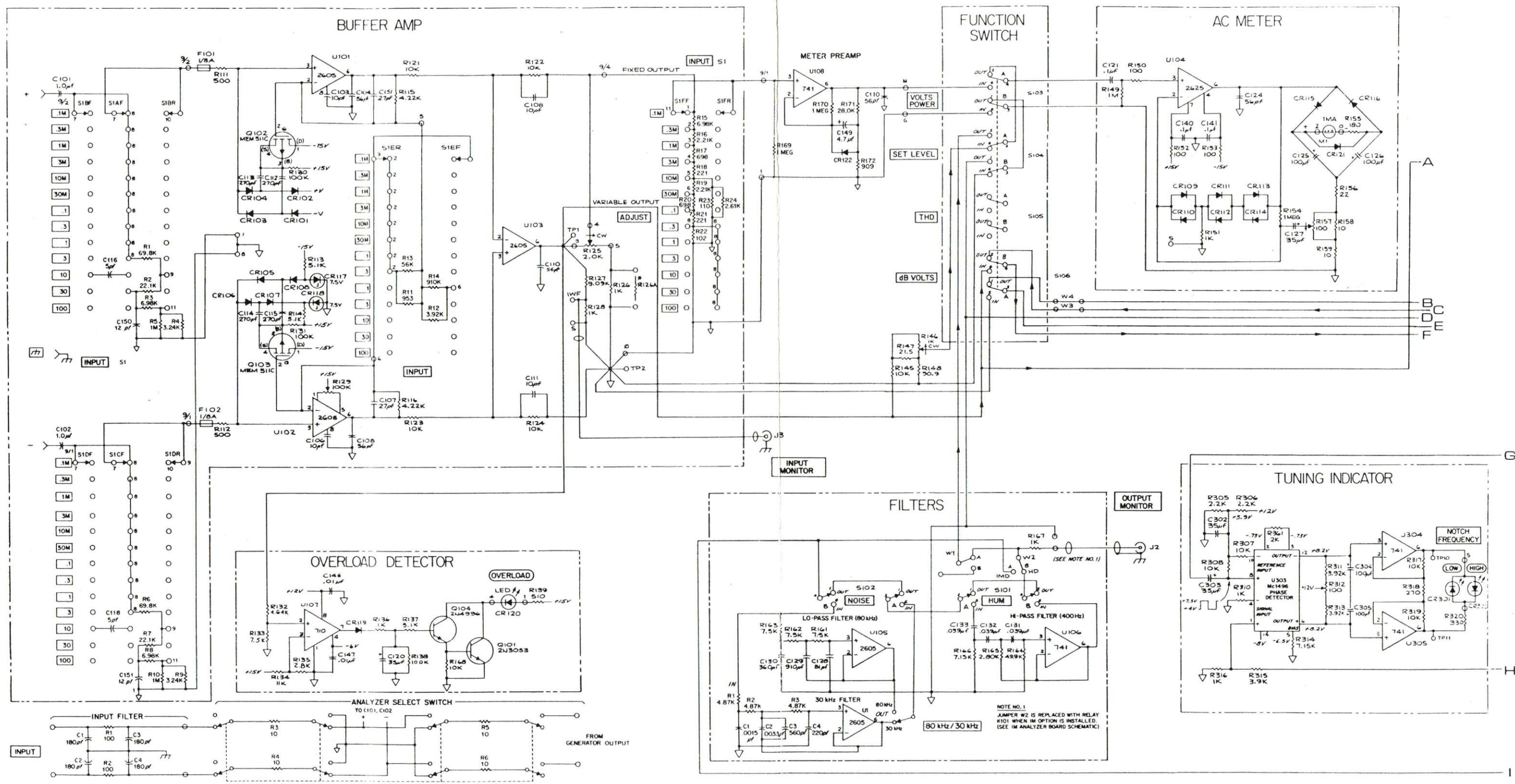
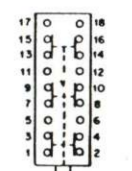
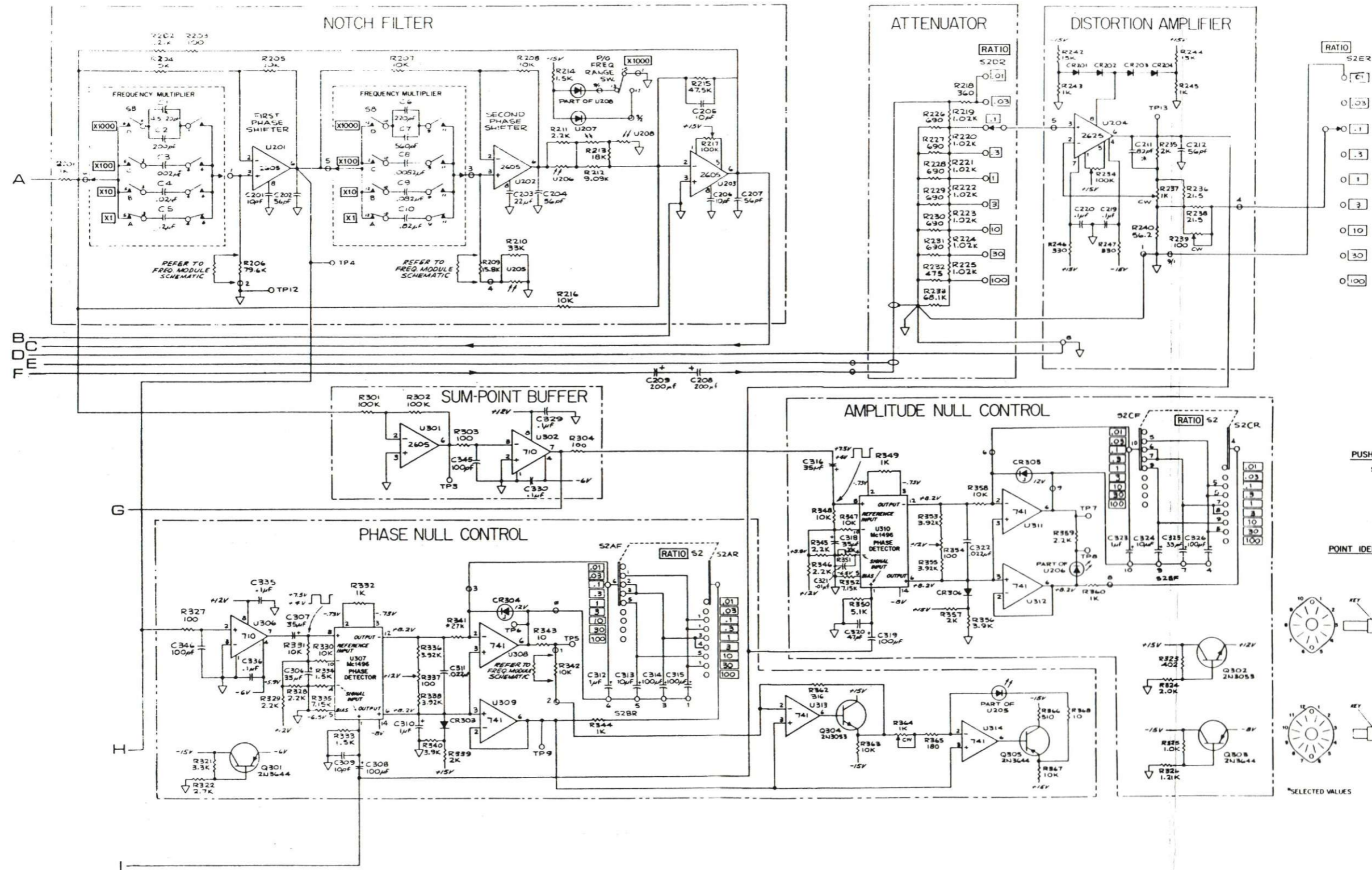

FIGURE 4-1
COMPONENT LOCATOR
ANALYZER BOARD



NOTE NO. 1
 JUMPER W2 IS REPLACED WITH RELAY
 K101 WHEN IM OPTION IS INSTALLED.
 (SEE IM ANALYZER BOARD SCHEMATIC)



PUSHBUTTON SWITCH DETAIL
SWITCH IN OUT POSITION
TOP VIEW

POINT IDENTIFICATION - ROTARY SWITCHES

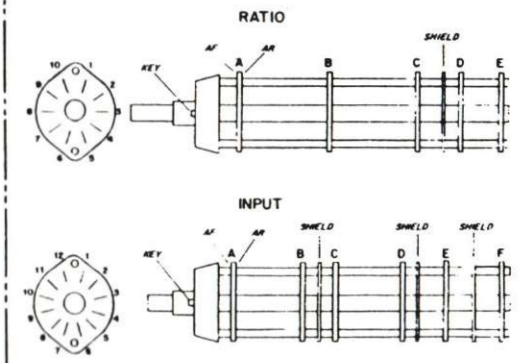

SELECTED VALUES

1710A
DISTORTION MEASUREMENT
SYSTEM

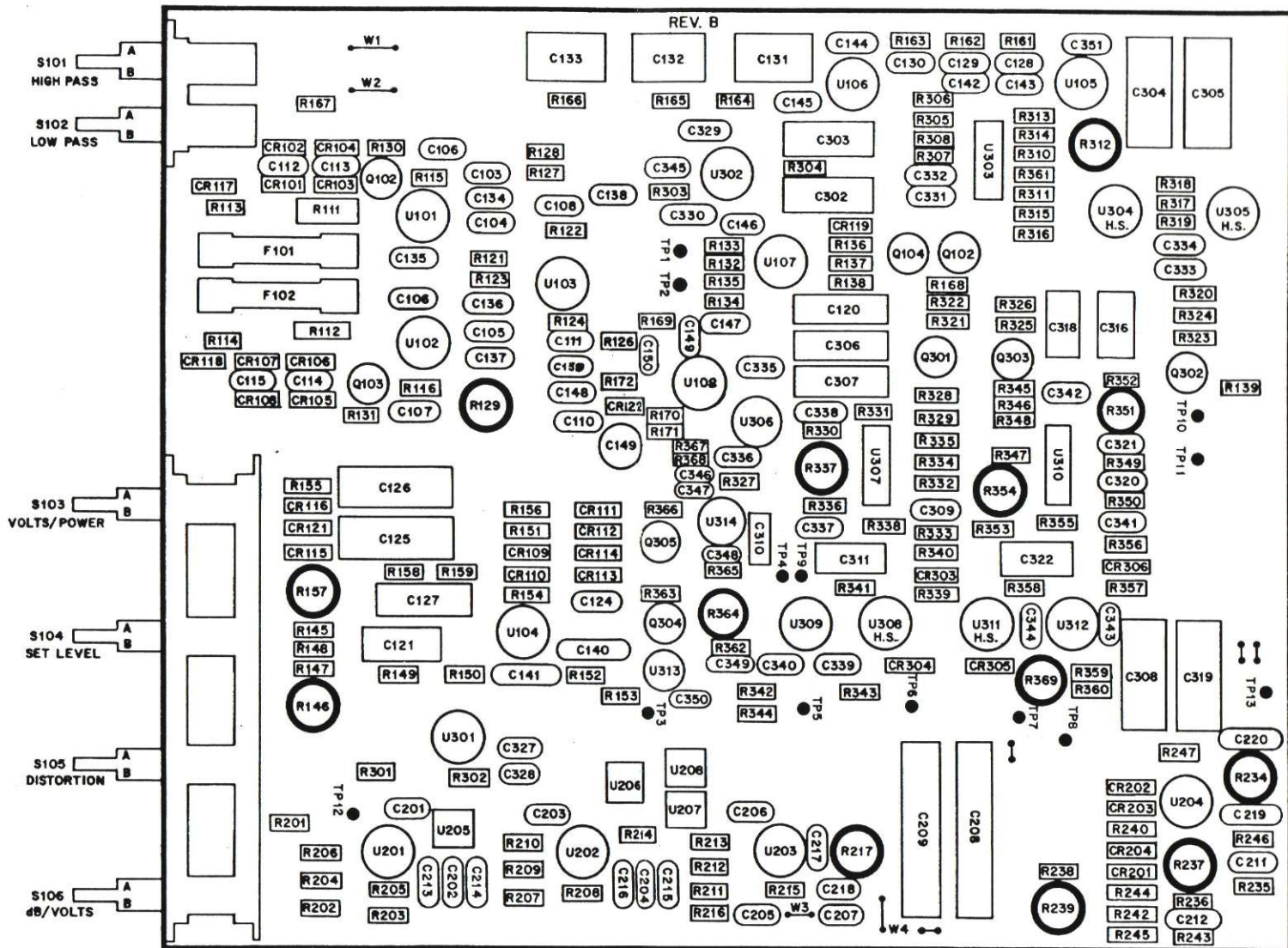

FIGURE 4-1(DUPLICATE)
COMPONENT LOCATOR
ANALYZER BOARD

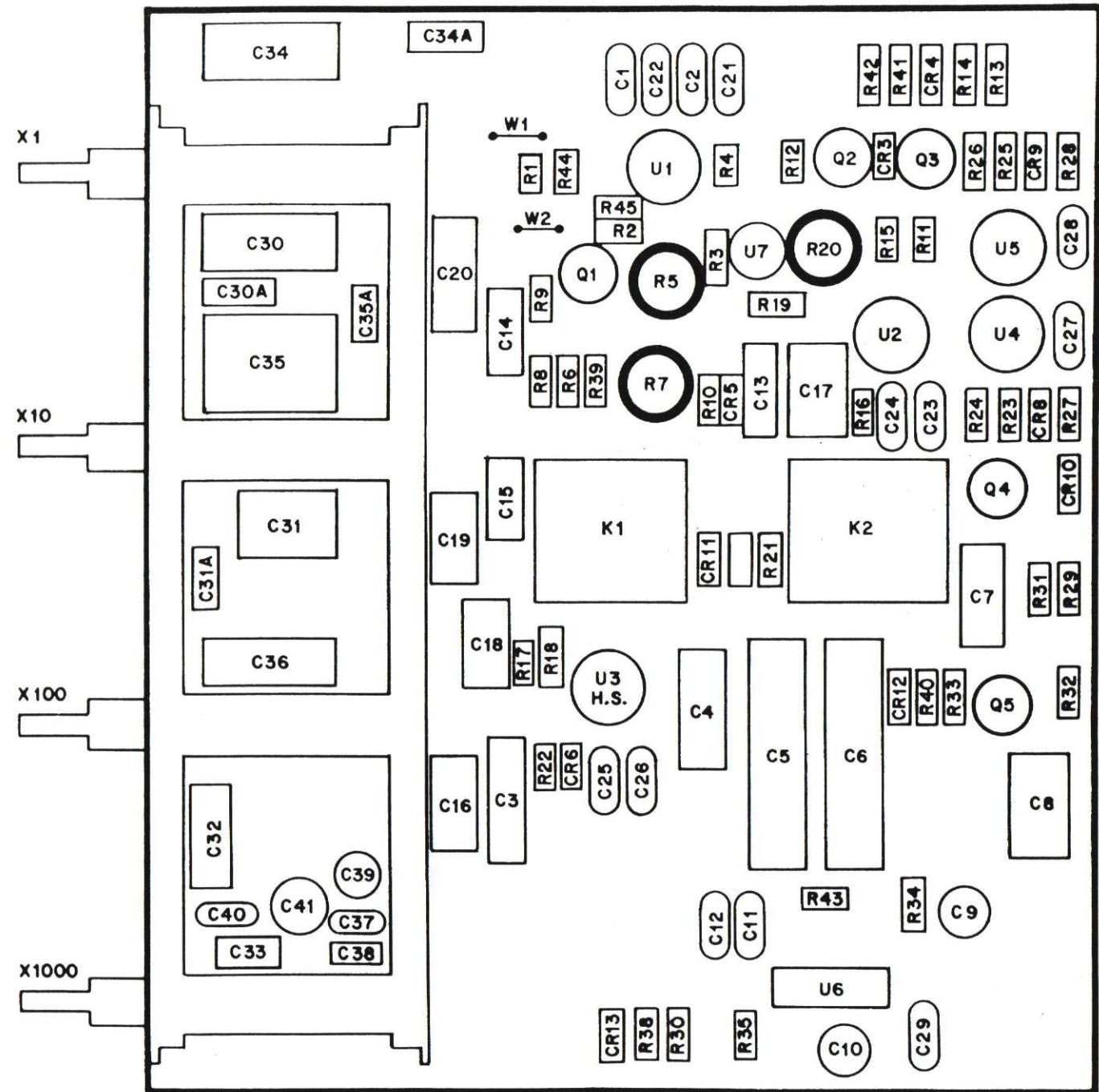
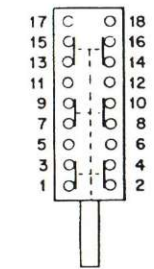
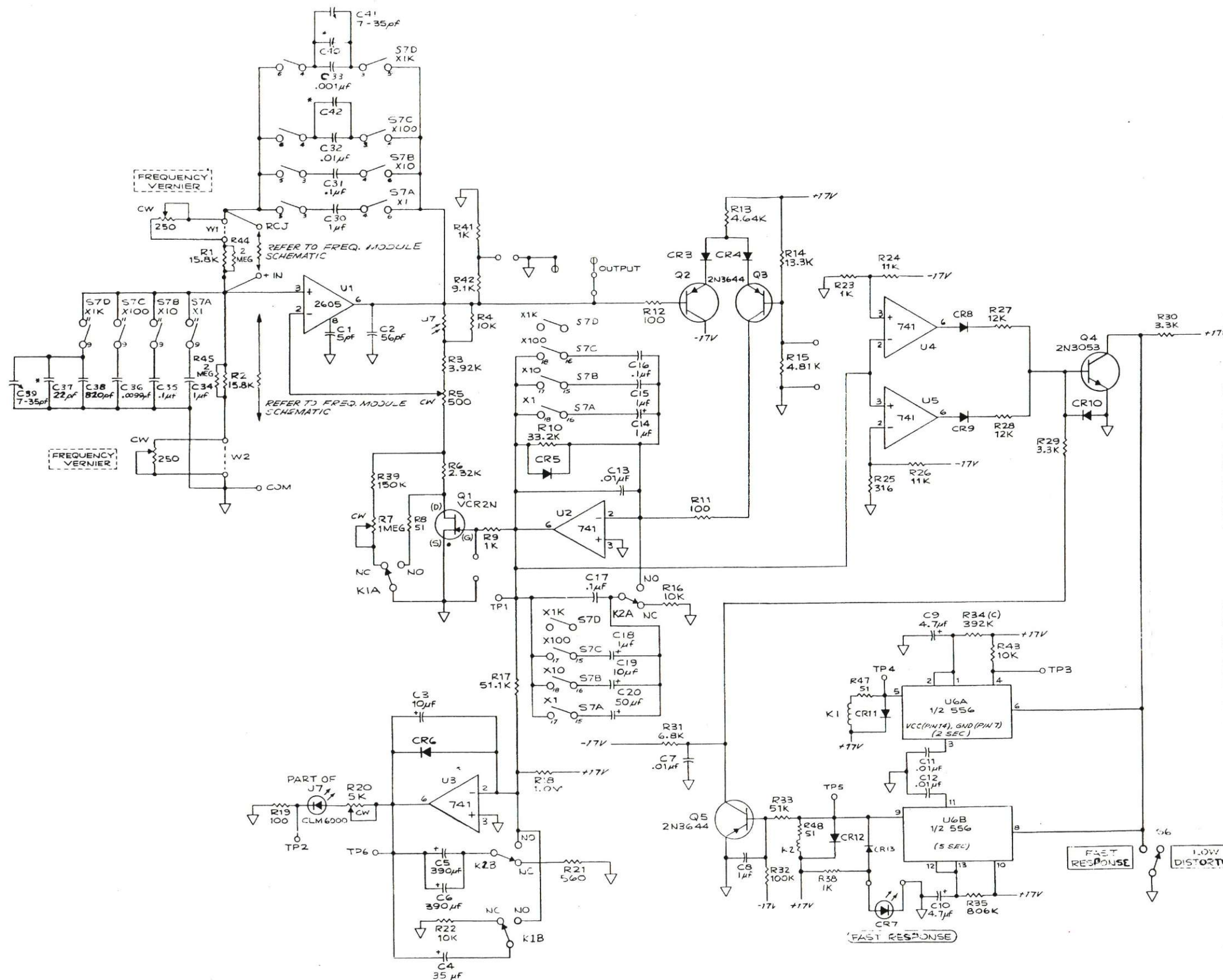

FIGURE 4-3
COMPONENT LOCATOR
OSCILLATOR BOARD



PUSHBUTTON SWITCH DETAIL
SWITCH IN OUT POSITION
TOP VIEW

*SELECTED VALUE

FIGURE 4-4
SCHEMATIC DIAGRAM
OSCILLATOR BOARD

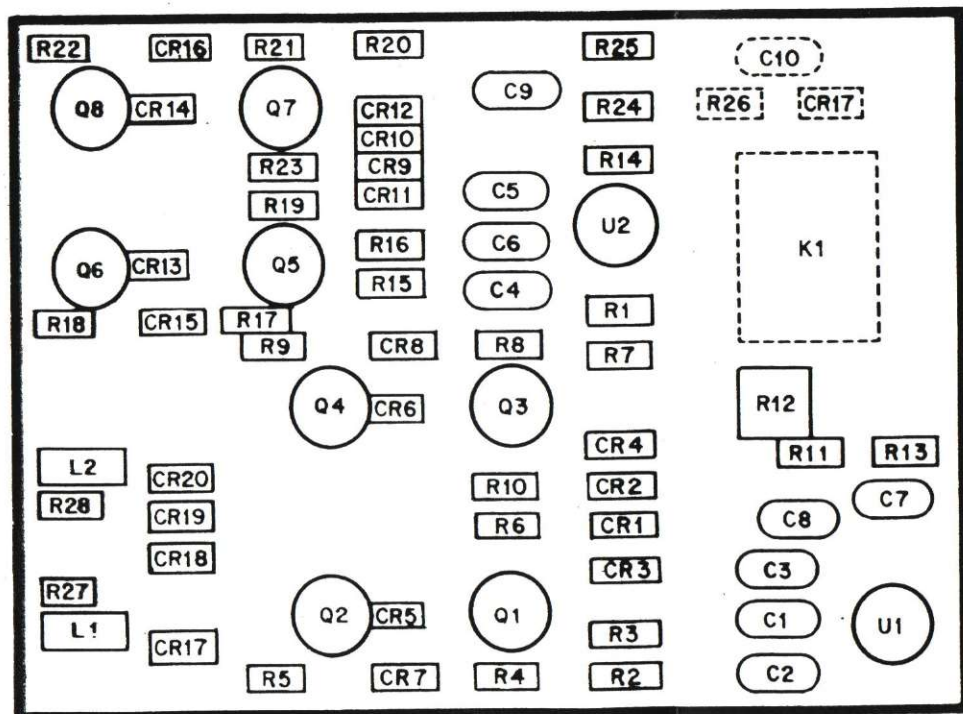
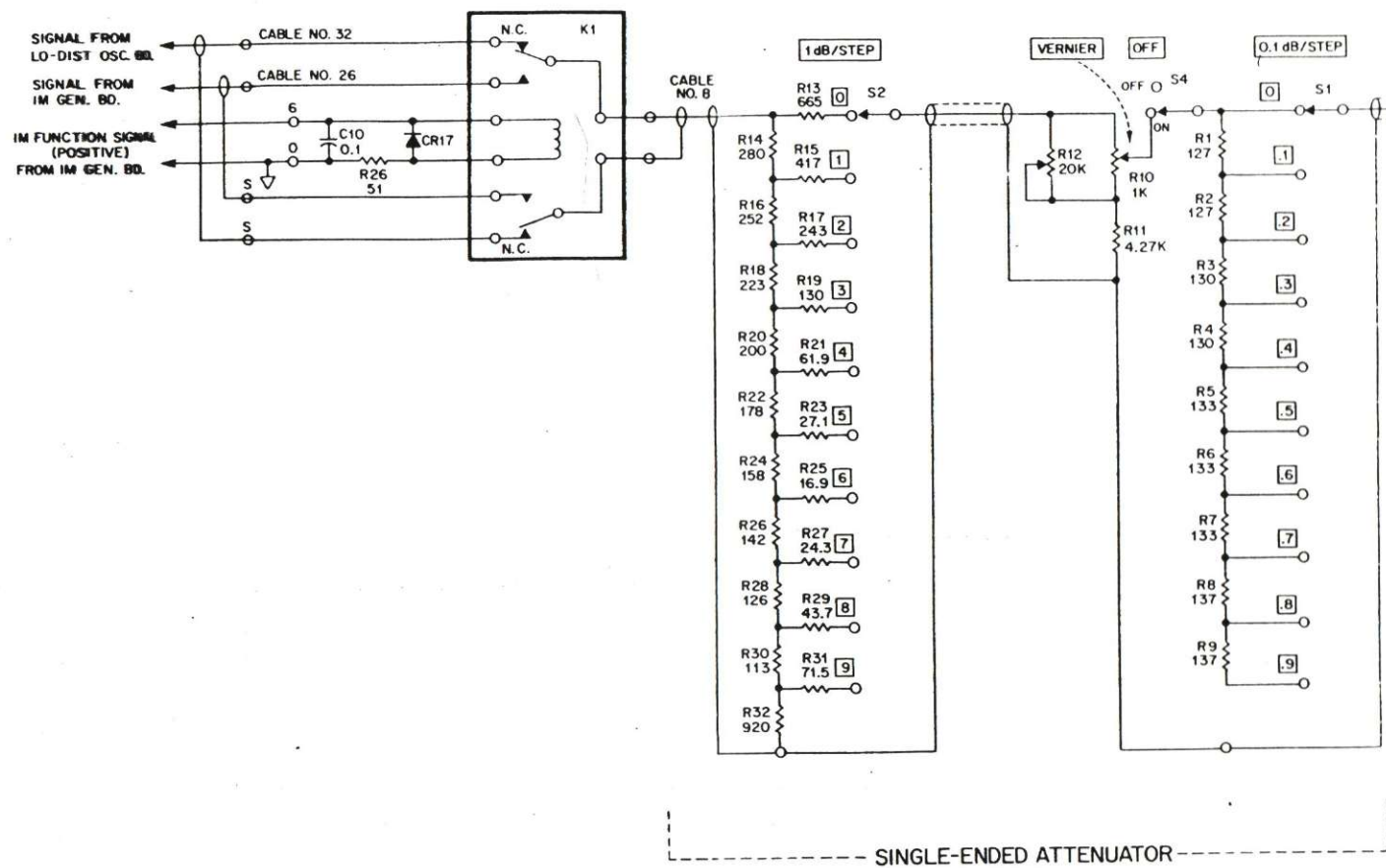

BALANCED AMPLIFIER BOARD

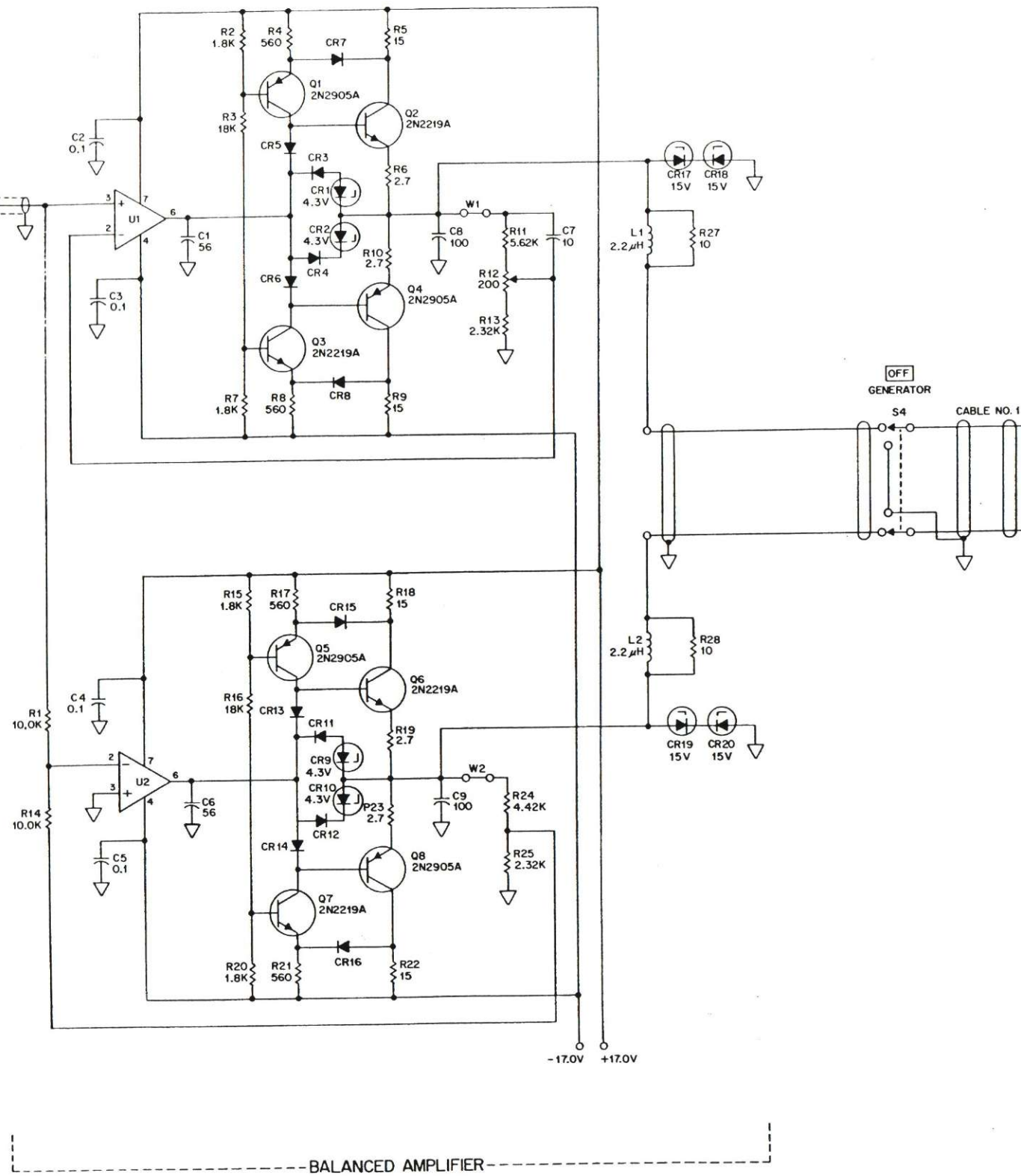

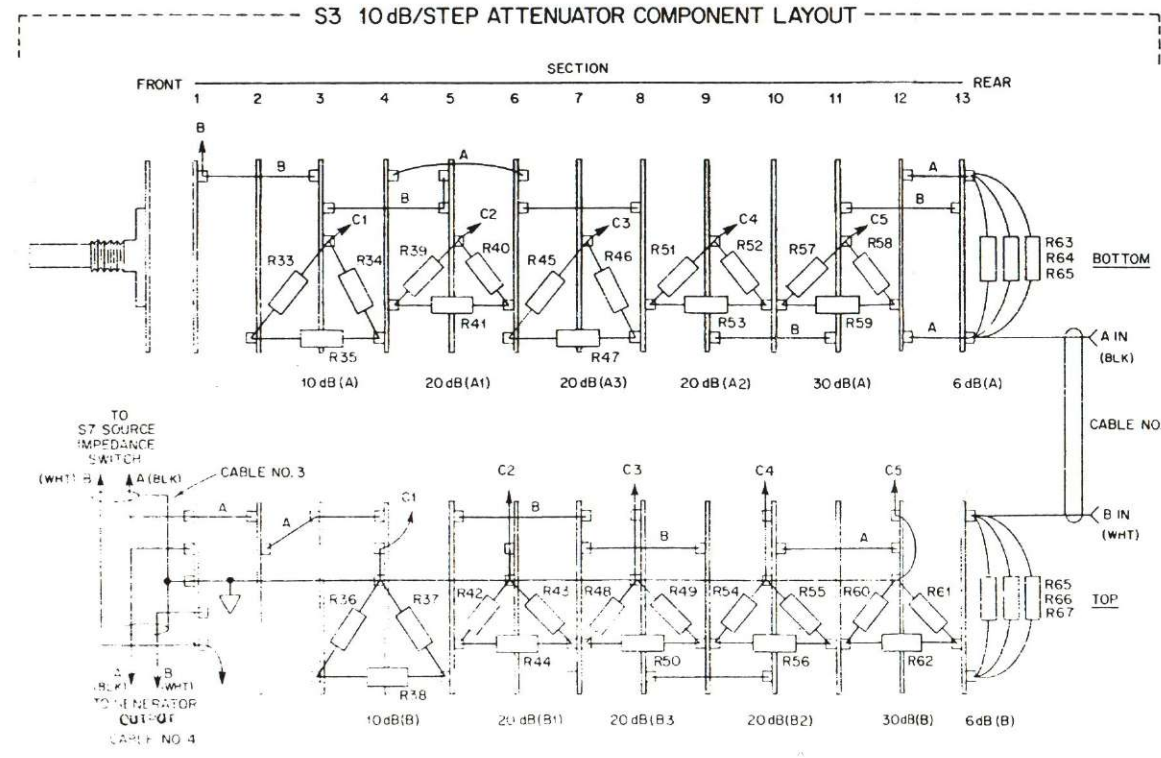
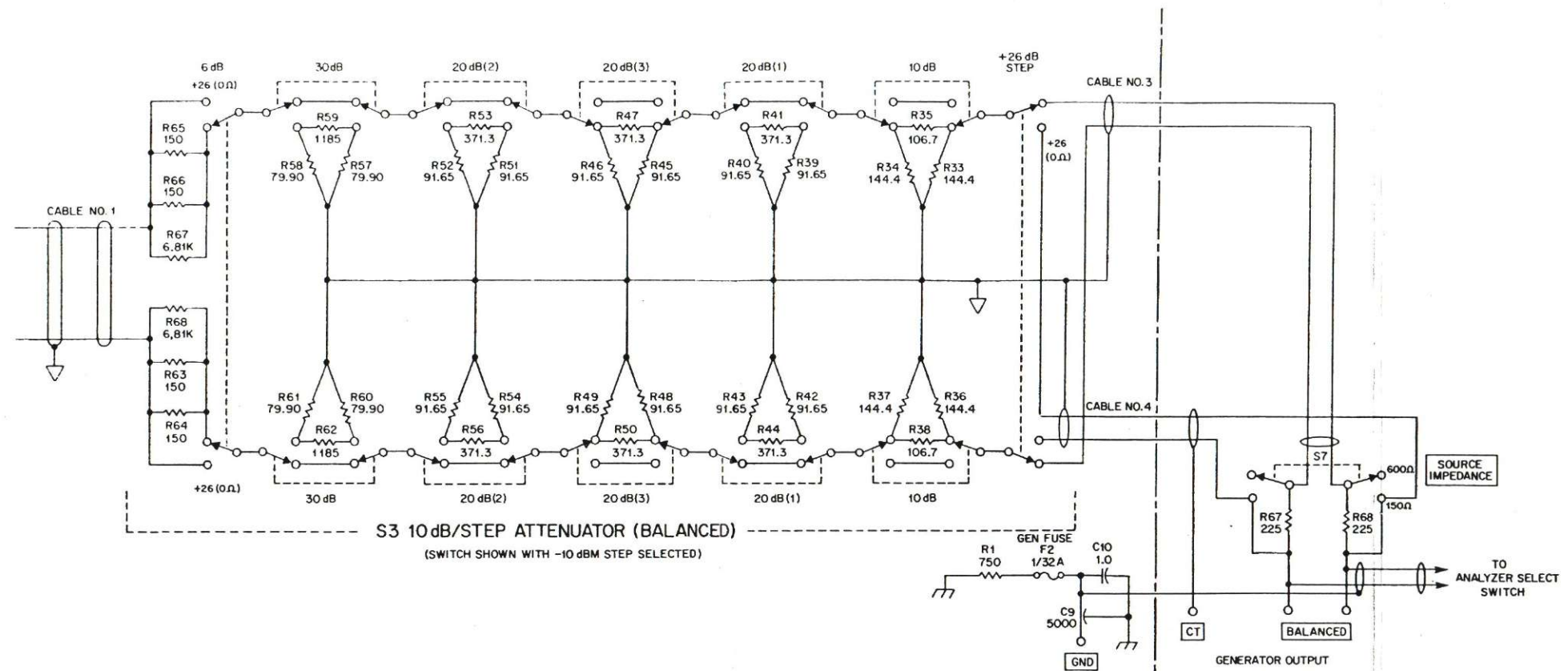

S3
10dB/STEP ATTENUATOR CODING

STEP	SECTIONS ACTUATED					
	30 dB	20 dB(1)	20 dB(2)	20 dB(3)	10 dB	6 dB
+26 dBm						X
+20 dBm						X
+10 dBm					X	X
0 dBm				X	X	X
-10 dBm				X	X	X
-20 dBm			X	X	X	X
-30 dBm			X	X	X	X
-40 dBm		X	X	X	X	X
-50 dBm		X	X	X	X	X
-60 dBm	X	X	X	X	X	X
-70 dBm	X	X	X	X	X	X
-80 dBm	X	X	X	X	X	X

MODEL 1710
BALANCED
AMPLIFIER/ATTENUATOR
8/76

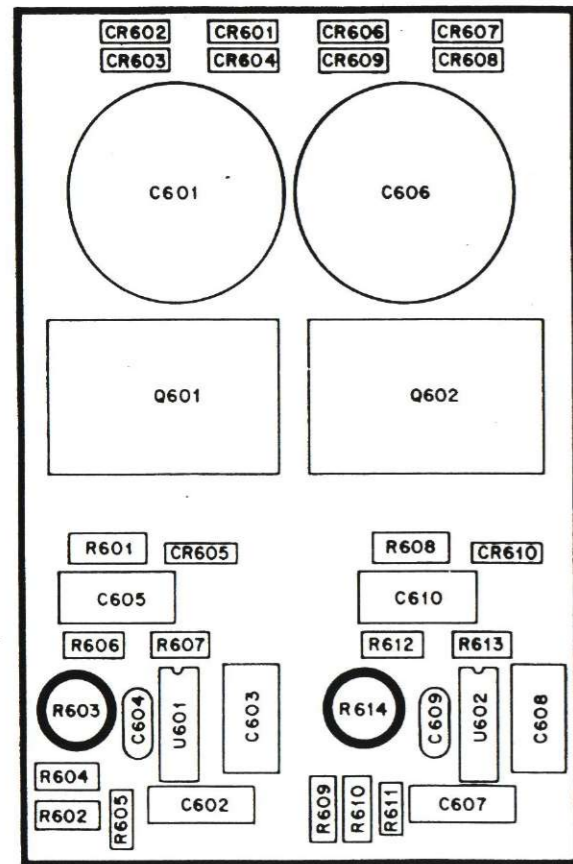
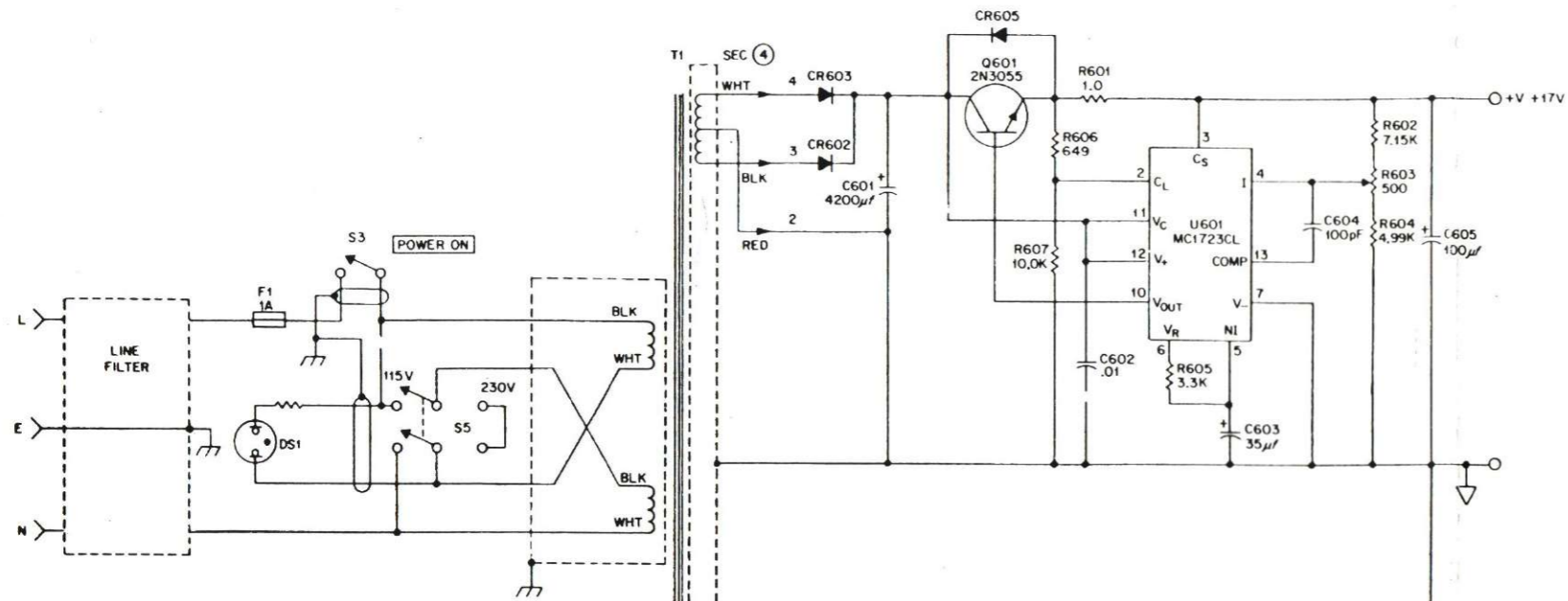

POWER SUPPLY BOARD

FIG. 4-7

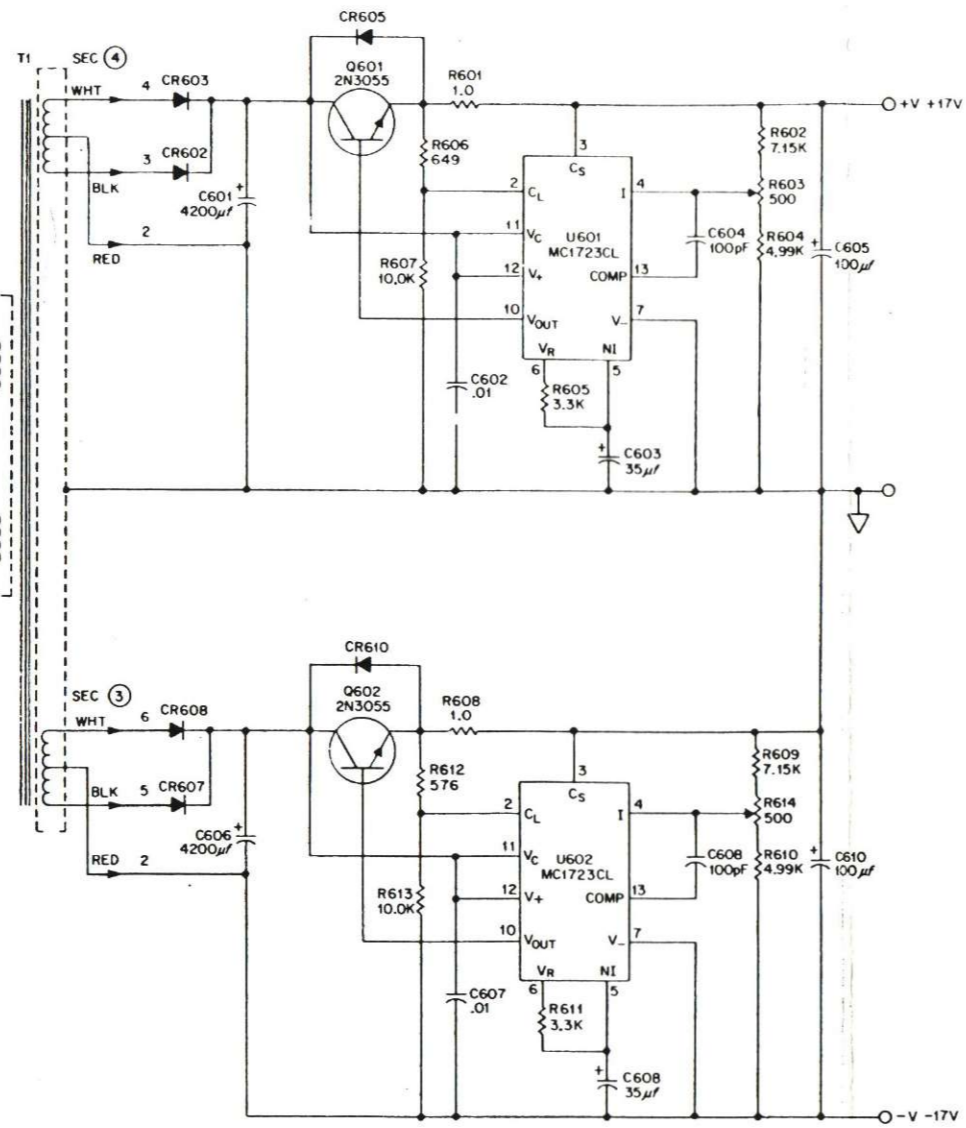

GENERATOR POWER SUPPLY

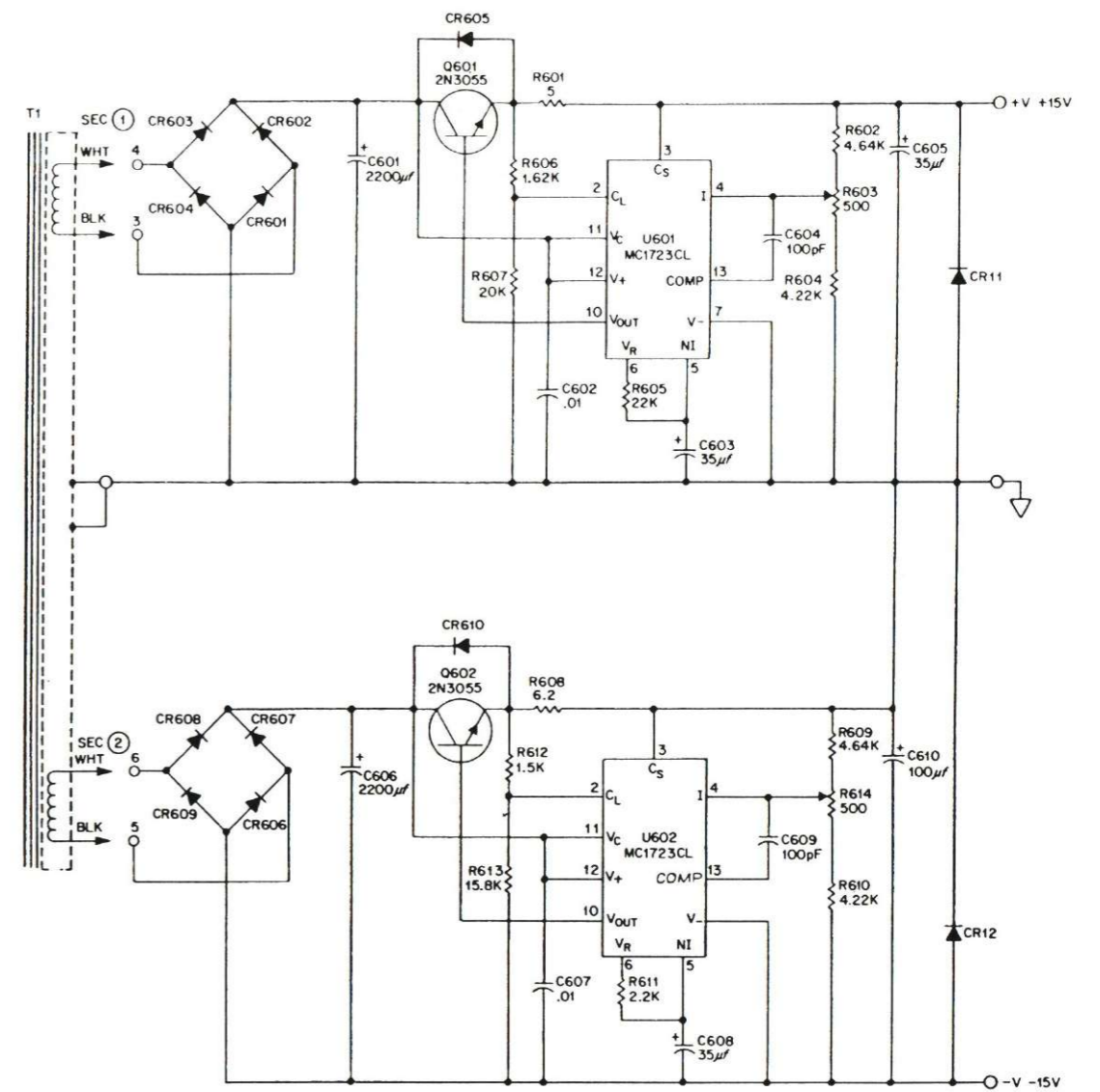

ANALYZER POWER SUPPLY

POWER SUPPLY

FIG. 4-8

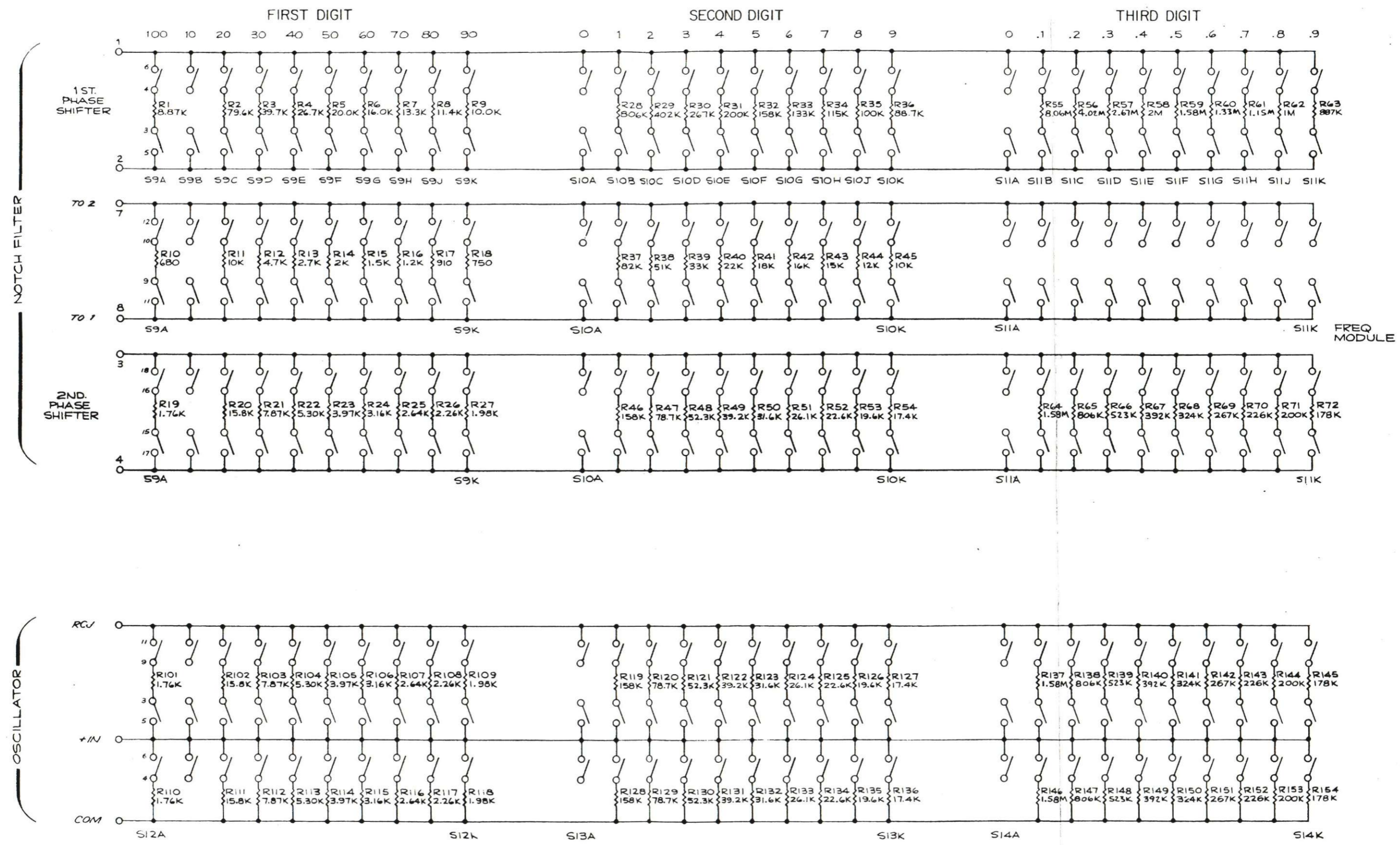

FREQUENCY MODULES

ECTION 5 - PARTS LIST

-1. GENERAL

-2. This section contains the following information for ordering replacement parts for this instrument:

- a. Sound Technology part number.
- b. Circuit diagram reference number.
- c. General description of part.

-3. ORDERING INFORMATION

-4. When ordering, each part should be identified by a Sound Technology Part Number. To order parts not listed herein, be sure to provide the following information:

- a. Instrument model number.
- b. Instrument serial number.
- c. Description of part.
- d. Function and location of part.
- e. Address your order or inquiry to:

Sound Technology
1400 Dell Avenue
Campbell, California 95008
Telephone: (408) 378 - 6540

PART NO	DESCRIPTION
100-0000	DIODE-LED RED CR7, 120, 301, 302
100-0000	DIODE-LED RED
000-0225	RES-FXD 225 0.1% 1/8W MF R67, 68
005-1787	RES-FXD 7.87K 0.25% 1/8W MF R32
005-2158	RES-FXD 15.8K 0.25% 1/8W MF R27
100-0100	RES-FXD 100 5% 1/4W R1, 2
100-2220	RES-FXD 22K 5% 1/4W R57
110-3002	RES-FXD 750 5% 1/2W CARBON R1
400-0009	RES-VAR 2K 10% 2W SPST SWITCH R125
400-0012	RES-VAR 1K 10% CCM MOD. LOG. CAR R8
400-0015	RES-VAR DUAL 250, 10% MODPOT
400-0016	RES-VAR 5K 10% MODPOT R31
000-0100	CAP-FXD 180PF 5% 500V MICA C1-4
020-0005	CAP-FXD 1UF 10% 400V TUBULAR C101, 102, 110
050-0002	CAP-STANDOFF, 5000PF MIN C9
000-0001	SWITCH-TOGGLE S3, 8
005-0000	SWITCH-SLIDE DPDT S6, 7
005-0001	SWITCH-SLIDE, LINE SELECT S5
005-0002	SWITCH-SLIDE DT3T PC TERM. MINI S9
100-0000	CONNECTOR-BNC JACK, SHORT
100-0001	CONNECTOR-BNC JACK, LONG
110-0001	CONNECTOR-BINDING POST, BROWN
110-0005	CONNECTOR-AC RECEPTACLE/FILTER
120-5000	CONN-SINGLE CONTACT, .093 SOCKET
120-5000	CONN-SINGLE CONTACT, .093 SOCKET
120-0007	TRANSFORMER-POWER 1710A
120-0008	END CAP, XFMR 1710A
1320-0002	METER-1MA, VRMS, DBM, 500 OHMS

3440-0000	LAMP-NEON, AMBER DS1
3445-0001	CONNECTOR-LAMP
3445-0002	RETAINING CLIP-LAMP
3480-0002	FUSE-1 AMP, 3AG F1
3480-0003	FUSE- 1/32 AMP 3AG FAST BLOW F2
3485-0000	FUSE HOLDER, 3AG
8000-0000	PUSHBUTTON-RECT, WHITE
8000-0001	KNOB-ROUND 0.7 DIA BEIGE
8000-0002	KNOB-BAR & SKIRT 0.7 DIA BEIGE
8000-0006	KNOB-ROUND 1/2 OD, 1/8 ID BEIGE
8000-0008	KNOB-CLEAR SKIRT, 0.1 DB STEPS

8000-0009	KNOB-CLEAR SKIRT, 10DB STEPS
8000-0010	KNOB-CLEAR SKIRT, 10 DB STEPS
8000-0012	KNOB-ROUND 1/2 OD, 1/4 ID BEIGE
8000-0013	PUSHBUTTON-BLK WITH ORN INSERT
8005-0000	BAIL-14 INCH
8005-0002	FEET-BAIL LEFT
8005-0003	FEET-BAIL RIGHT
8005-0004	FEET-RUBBER
8005-0005	HANDLE-10 INCH

SUBASSEMBLY PARTS

PART NO	DESCRIPTION
01700-30002	ASSY-PC, OSC FREQ-MSD
01700-30003	ASSY-PC, OSCILLATOR
01700-30004	ASSY-PC, ANAL FREQ MSD
01700-30005	ASSY-PC, ANAL MULTIPLIER
01700-30006	ASSY-PC, ANALYZER
01700-30010	ASSY-PC, ANAL FREQ 2ND DIGIT
01700-30011	ASSY-PC, ANAL FREQ 3RD DIGIT
01700-30012	ASSY-PC, OSC FREQ 2ND DIGIT
01700-30013	ASSY-PC, OSC FREQ 3RD DIGIT
01700-30015	RATIO SWITCH ASSEMBLY
01700-30016	ASSY-PC AUTO SET LEVEL
01700-30017	ASSY-PC, IM ANALYZER
01710-30001	INPUT SWITCH ASSEMBLY
01710-30003	ATTENUATOR ASSEMBLY
01710-30008	ASSY-PC, PWR SUP, GENERATOR
01710-30009	ASSY-PC, PWR SUP, ANALYZER
01710-30010	ASSY-PC, 30KHZ FILTER
01710-30011	ASSY-PC, SYNC SIGNAL
01710-30012	ASSY, METER SELECT

01700-30002 ASSY-PC, OSC FREQ

PART NO	DESCRIPTION
1005-1176	RES-FXD 1.76K 0.25% 1/8W MF R101, 110
1005-1198	RES-FXD 1.98K 0.25% 1/8W MF R109, 118
1005-1226	RES-FXD 2.26K 0.25% 1/8W MF R108, 117
1005-1264	RES-FXD 2.64K 0.25% 1/8W MF R107, 116
1005-1316	RES-FXD 3.16K 0.25% 1/8W MF R106, 115
1005-1397	RES-FXD 3.97K 0.25% 1/8W MF R105, 114
1005-1530	RES-FXD 5.30K 0.25% 1/8W MF R104, 113
1005-1787	RES-FXD 7.87K 0.25% 1/8W MF R103, 112
1005-2158	RES-FXD 15.8K 0.25% 1/8W MF R102, 111
3015-0003	SWITCH-PB, 10 STA-4P
3150-0002	SPACER-PUSHBUTTON SW, DOGBONE

01700-30003 ASSY-PC, OSCILLATOR

PART NO	DESCRIPTION
0000-0001	TRANS 2N3644 PNP SI Q2, 3, 5
0005-0000	TRANS 2N3053 NPN SI Q4

0025-0000	TRANS-FET VCR2N N-CHAN Q1
0100-0001	IC-OP AMP 741 U2-5
0100-0007	IC-OP AMP 2605 GRADE 2 RED U1
0110-0000	IC-TIMER 556 U6
0200-0000	DIODE-GEN 1N914A SI CR3-6, 8-13
0305-0002	PHOTOCELL-LED GRADE 2 RED U7
1005-1421	RES-FXD 4.81K 0.25% 1/8W MF R15
1005-2133	RES-FXD 13.3K 0.25% 1/8W MF R14
1005-2158	RES-FXD 15.8K 0.25% 1/8W MF R1, 2
1015-0100	RES-FXD 100 1% 1/8W MF R19
1015-0316	RES-FXD 316 1% 1/8W MF R25
1015-1100	RES-FXD 1K 1% 1/8W MF R23
1015-1232	RES-FXD 2.32K 1% 1/8W MF R6
1015-1392	RES-FXD 3.92K 1% 1/8W MF R3
1015-1422	RES-FXD 4.22K 1% 1/8W MF R15
1015-1422	RES-FXD 4.22K 1% 1/8W MF R15
1015-1464	RES-FXD 4.64K 1% 1/8W MF R13
1015-2100	RES-FXD 10K 1% 1/8W MF R14
1015-2100	RES-FXD 10K 1% 1/8W MF R14
1015-2110	RES-FXD 11K 1% 1/8W MF R24, 26
1015-2332	RES-FXD 33.2K 1% 1/8W MF R10
1015-2511	RES-FXD 51.1K 1% 1/8W MF R17
1015-4100	RES-FXD 1M 1% 1/8W MF R18
1100-0051	RES-FXD 51 5% 1/4W R8, 40, 41
1100-0100	RES-FXD 100 5% 1/4W R11, 12

1100-0560	RES-FXD 560 5% 1/4W R21
1100-1100	RES-FXD 1K 5% 1/4W R9, 38, 41
1100-1330	RES-FXD 3.3K 5% 1/4W R29, 30
1100-1680	RES-FXD 6.8K 5% 1/4W R31
1100-1910	RES-FXD 9.1K 5% 1/4W R42
1100-2100	RES-FXD 10K 5% 1/4W R16, 22, 43
1100-2120	RES-FXD 12K 5% 1/4W R27, 28
1100-2510	RES-FXD 51K 5% 1/4W R33
1100-3100	RES-FXD 100K 5% 1/4W R32
1100-3150	RES-FXD 150K 5% 1/4W R39
1100-3390	RES-FXD 390K 5% 1/4W R34
1100-3820	RES-FXD 820K 5% 1/4W R35
1100-4200	RES-FXD 2M 5% 1/4W R44, 45
1410-0002	RES-VAR 500 TRIMPOT CERMET R5
1410-0004	RES-VAR 5K TRIMPOT CERMET R20
1410-0006	RES-VAR 1M TRIMPOT CERMET R7

2000-0005	CAP-FXD 5PF 10% 500V MICA C1
2000-0022	CAP-FXD 22PF 5% 500V MICA C40
2000-0033	CAP-FXD 33PF 5% 500V MICA C37
2000-0056	CAP-FXD 56PF 5% 500V MICA C2
2020-0000	CAP-FXD 0.01UF 10% 100V MYLAR C7, 13
2020-0003	CAP-FXD 0.1UF 10% 100V MYLAR C16, 17
2025-0000	CAP-FXD 0.001UF 1% 33V PLYSTR C33
2025-0003	CAP-FXD 0.01UF 1% 33V PLYSTR C32
2025-0006	CAP-FXD 0.1UF 1% 33V PLYSTR C31, 35
2025-0009	CAP-FXD 1.007UF 1% 100V FILM C30, 34
2025-0016	CAP-FXD .0068UF 2.5% 63V PYSTR C30A, 34A
2025-0018	CAP-FXD 0.0099UF 1% 63V PLYSTR C36
2025-0019	CAP-FXD 680PF 2.5% 63V PLYSTR C31A, 35A
2025-0019	CAP-FXD 680PF 2.5% 63V PLYSTR C31A, 35A
2025-0023	CAP-FXD 820PF 1% 63V PLYSTR C38
2040-0000	CAP-FXD 0.01UF 100V CERAMIC C11, 12, 21-29
2100-0000	CAP-FXD 4.7UF 10% 35V TANT C9, 10
2100-0001	CAP-FXD 1UF 25V ELECT AL C8, 14, 15, 18
2100-0003	CAP-FXD 10UF 25V ELECT AL C3, 19
2100-0004	CAP-FXD 35UF 25V ELECT AL C20
2100-0005	CAP-FXD 50UF 25V ELECT AL C4
2100-0008	CAP-FXD 390UF 12V ELECT AL C5, 6
2100-0016	CAP-FXD 1UF 35V ELECT TANT
2205-0004	CAP-VAR 7-35PF TRIMMER CERAMIC C39, 41

3015-0002	SWITCH-PB, 4 STA(2 SPACE)-6P S7
3105-0000	SOCKET-IC 8 PIN ROUND
3105-0001	SOCKET-IC 14 PIN DIP
3120-0000	CONN-SINGLE CONTACT, .093 PIN
3150-0002	SPACER-PUSHBUTTON SW, DOGBONE
3400-0000	RELAY-2 FORM C K1, 2
3600-0000	HEAT SINK-ROUND FINNED T05

01700-30004 ASSY-PC, ANAL FREQ

PART NO	DESCRIPTION
1005-1176	RES-FXD 1.76K 0.25% 1/8W MF R19
1005-1198	RES-FXD 1.98K 0.25% 1/8W MF R27
1005-1226	RES-FXD 2.26K 0.25% 1/8W MF R26
1005-1264	RES-FXD 2.64K 0.25% 1/8W MF R25
1005-1316	RES-FXD 3.16K 0.25% 1/8W MF R24
1005-1397	RES-FXD 3.97K 0.25% 1/8W MF R23
1005-1530	RES-FXD 5.30K 0.25% 1/8W MF R22
1005-1787	RES-FXD 7.87K 0.25% 1/8W MF R21
1005-1887	RES-FXD 8.87K 0.25% 1/8W MF R1

1005-2100	RES-FXD 10K 0.25% 1/8W MF R9
1005-2114	RES-FXD 11.4K 0.25% 1/8W MF R8
1005-2133	RES-FXD 13.3K 0.25% 1/8W MF R7
1005-2158	RES-FXD 15.8K 0.25% 1/8W MF R20
1005-2160	RES-FXD 16.0K 0.25% 1/8W MF R6
1005-2200	RES-FXD 20.0K 0.25% 1/8W MF R5
1005-2267	RES-FXD 26.7K 0.25% 1/8W MF R4
1005-2397	RES-FXD 39.7K 0.25% 1/8W MF R3
1005-2796	RES-FXD 79.6K 0.25% 1/8W MF R2
1100-0680	RES-FXD 680 5% 1/4W R10
1100-0750	RES-FXD 750 5% 1/4W R18
1100-0910	RES-FXD 910 5% 1/4W R17
1100-1120	RES-FXD 1.2K 5% 1/4W R16
1100-1150	RES-FXD 1.5K 5% 1/4W R15
1100-1200	RES-FXD 2K 5% 1/4W R14
1100-1270	RES-FXD 2.7K 5% 1/4W R13
1100-1470	RES-FXD 4.7K 5% 1/4W R12
1100-2100	RES-FXD 10K 5% 1/4W R11
3015-0004	SWITCH-PB, 10 STA-6P S9

01700-30005 ASSY-PC, ANAL MULTIPL

PART NO	DESCRIPTION
2025-0001	CAP-FXD 0.002UF 1% 33V PLYST C3
2025-0002	CAP-FXD 0.0082UF 1% 33V PLYS C8
2025-0004	CAP-FXD 0.02UF 1% 33V PLYST C4
2025-0005	CAP-FXD 0.082UF 1% 33V PLYST C9
2025-0007	CAP-FXD 0.2UF 1% 100V FILM C5
2025-0008	CAP-FXD 0.82UF 1% 100V FILM C10
2025-0020	CAP-FXD 200PF 1% 63V PLYSTR C2
2025-0021	CAP-FXD 220PF 1% 63V PLYSTR C6
2025-0022	CAP-FXD 560PF 1% 63V PLYSTR C7
2205-0000	CAP-VAR 4.5-20PF TRIMMER CER C1
3015-0002	SWITCH-PB, 4 STA(2 SPACE)-6P S8

01700-30006
ASSY-PC ANALYZER

PART NO	DESCRIPTION
0000-0001	TRANS 2N3644 PNP SI Q301, 303, 305
0005-0000	TRANS 2N3053 NPN SI Q101, 302, 304
0005-0002	TRANS 2N4996 NPN SI Q104
0020-0000	TRANS-FET MEM5110 MOS P-CHAN Q102, 103
0100-0000	IC-COMPARATOR 710 U107, 302, 306
0100-0001	IC-OP AMP 741 U 108, 304, 305, 308, 309, 311-314
0100-0001	IC-OP AMP 741
0100-0002	IC-BAL MOD./DEMOC 1496 U303, 307, 310
0100-0003	IC-OP AMP 2625 U104, 204
0100-0005	IC-OP AMP 2605 GRADE 1 BROWN U103
0100-0008	IC-OP AMP 2605 GRADE 3 ORANGE U101, 102
0100-0009	IC-OP AMP 2605 GRADE 4 YELLOW U201, 202
0100-0010	IC-OP AMP 2605 GRADE 5 GREEN U203, 301
0100-0014	IC-OP AMP 2605 GRADE 6 BLUE U105
0100-0014	IC-OP AMP 2605 GRADE 6 BLUE U108
0200-0000	DIODE-GEN 1N914A SI 306 CR101-108, 109-116, 119, 121, 201-206, 303
0200-0000	DIODE-GEN 1N914A SI CR122
0205-0000	DIODE-ZENER 1N755 7.5V CR117, 118
0205-0001	DIODE-ZENER 1N963A 12V CR 305
0305-0001	PHOTOCELL-LED GRADE 1 BROWN U205
0305-0004	PHOTOCELL-LED GRADE 4 YELLOW U206
0305-0006	PHOTOCELL-LED GRADE 6 BLUE U207, 208
1005-0909	RES-FXD 909 0.25% 1/8W MF R172
1005-1422	RES-FXD 4 22K 0.25% 1/8W MF R115, 116
1005-2100	RES-FXD 10K 0.25% 1/8W MF R121-124
1005-2158	RES-FXD 15.8K 0.25% 1/8W MF R209
1005-2280	RES-FXD 28.0K 0.25% 1/8W MF R171
1005-2796	RES-FXD 79.6K 0.25% 1/8W MF R206
1015-0010	RES-FXD 10 1% 1/8W MF R158, 159
1015-0021	RES-FXD 21.5 1% 1/8W MF R147, 236, 238
1015-0056	RES-FXD 56.2 1% 1/8W MF R240
1015-0090	RES-FXD 90.9 1% 1/8W MF R148
1015-0316	RES-FXD 316 1% 1/8W MF R362
1015-0402	RES-FXD 402 1% 1/8W MF R323
1015-1100	RES-FXD 1K 1% 1/8W MF R126, 128, 201, 325, 332, 349
1015-1121	RES-FXD 1.21K 1% 1/8W MF R202, 326
1015-1200	RES-FXD 2K 1% 1/8W MF R235, 324
1015-1280	RES-FXD 2.8K 1% 1/8W MF R135
1015-1392	RES-FXD 3.92K 1% 1/8W MF R311, 313, 336, 338, 353, 355
1015-1464	RES-FXD 4.64K 1% 1/8W MF R132

1015-1715	RES-FXD 7.15K 1% 1/8W MF R 314, 335, 352
1015-1750	RES-FXD 7.5K 1% 1/8W MF R133, 161-163
1015-1909	RES-FXD 9.09K 1% 1/8W MF R127, 212
1015-2100	RES-FXD 10K 1% 1/8W MF R145, 204, 205, 207, 208, 216, 342
1015-2110	RES-FXD 11K 1% 1/8W MF R134
1015-2475	RES-FXD 47.5K 1% 1/8W MF R215
1015-2499	RES-FXD 49.9K 1% 1/8W MF
1100-0010	RES-FXD 10 5% 1/4W R343, 368
1100-0022	RES-FXD 22 5% 1/4W R156
1100-0100	RES-FXD 100 5% 1/4W R150, 152, 153, 303, 304, 327
1100-0120	RES-FXD 120 5% 1/4W R203
1100-0180	RES-FXD 180 5% 1/4W R155, 365
1100-0270	RES-FXD 270 5% 1/4W R318
1100-0330	RES-FXD 330 5% 1/4W R246, 247, 320
1100-0510	RES-FXD 510 5% 1/4W R139, 366
1100-0750	RES-FXD 750 5% 1/4W R359
1100-1100	RES-FXD 1K 5% 1/4W R136, 151, 167, 243, 245, 310, 316, 344, 360
1100-1150	RES-FXD 1.5K 5% 1/4W R214, 333, 334
1100-1200	RES-FXD 2K 5% 1/4W R339, 357, 361
1100-1220	RES-FXD 2.2K 5% 1/4W R211, 305, 306, 328, 329, 345, 346
1100-1270	RES-FXD 2.7K 5% 1/4W R322
1100-1330	RES-FXD 3.3K 5% 1/4W R321
1100-1390	RES-FXD 3.9K 5% 1/4W R315, 340, 356
1100-1510	RES-FXD 5.1K 5% 1/4W R113, 114, 137, 350
1100-2100	RES-FXD 10K 5% 1/4W 358, 363, 367 R168, 307, 308, 317, 319, 330, 331, 347, 348
1100-2150	RES-FXD 15K 5% 1/4W R242, 244
1100-2180	RES-FXD 18K 5% 1/4W
1100-2270	RES-FXD 27K 5% 1/4W R341
1100-2330	RES-FXD 33K 5% 1/4W R210
1100-3100	RES-FXD 100K 5% 1/4W R130, 131, 138, 301, 302
1100-4100	RES-FXD 1M 5% 1/4W R149, 154, 169
1100-4100	RES-FXD 1M 5% 1/4W R170
1200-2000	RES-FXD 500 3W MW R111, 112
1410-0001	RES-VAR 100 TRIMPOT CERMET R157, 239, 312, 337, 359
1410-0003	RES-VAR 1K TRIMPOT CERMET R146, 237
1410-0005	RES-VAR 100K TRIMPOT CERMET R129, 217, 234
1410-0007	RES-VAR 20K TRIMPOT CERMET R351
1411-0000	RES-VAR 1K TRIMPOT WIREWOUND R364
1411-0001	RES-VAR 5K 5% TRIMPOT WIREWOUND R369
2000-0010	CAP-FXD 10PF 5% 500V MICA C103, 106, 108, 111, 201, 205, 206, 309
2000-0012	CAP-FXD 12PF 5% 500V MICA

01700-30010
ASSY-PC, ANAL FREQ 2ND

PART NO	DESCRIPTION
1005-2174	RES-FXD 17.4K 0.25% 1/8W MF R54
1005-2196	RES-FXD 19.6K 0.25% 1/8W MF R53
1005-2226	RES-FXD 22.6K 0.25% 1/8W MF R52
1005-2887	RES-FXD 88.7K 0.25% 1/8W MF R36
1005-3100	RES-FXD 100K 0.25% 1/8W MF R35
1005-3115	RES-FXD 115K 0.25% 1/8W MF R34

2000-0022	CAP-FXD 22PF 5% 500V MICA C203
2000-0027	CAP-FXD 27PF 5% 500V MICA C107
2000-0047	CAP-FXD 47PF 5% 500V MICA C320
2000-0051	CAP-FXD 51PF 5% 500V MICA C128
2000-0051	CAP-FXD 51PF 5% 500V MICA C128
2000-0056	CAP-FXD 56PF 5% 500V MICA C104, 105, 110, 124, 143, 202, 204, 207, 212
2000-0068	CAP-FXD 68PF 5% 500V MICA C211
2000-0100	CAP-FXD 100PF 5% 500V MICA C345, 346
2000-0270	CAP-FXD 270PF 5% 500V MICA C112-115
2000-0360	CAP-FXD 360PF 5% 500V MICA C130
2000-0360	CAP-FXD 360PF 5% 500V MICA C130
2000-0910	CAP-FXD 910PF 5% 500V MICA C129
2000-0910	CAP-FXD 910PF 5% 500V MICA C129
2020-0001	CAP-FXD 0.022UF 10% 100V MYLAR C311, 322
2020-0003	CAP-FXD 0.1UF 10% 100V MYLAR C121
2025-0010	CAP-FXD .039UF 2.5% 33V PLYSTR C131-133
2025-0012	CAP-FXD .0015UF 2.5% 63V PLYSTR
2025-0014	CAP-FXD .0033UF 2.5% 63V PLYSTR
2025-0021	CAP-FXD 220PF 1% 63V PLYSTR
2025-0022	CAP-FXD 560PF 1% 63V PLYSTR C1.
2040-0000	CAP-FXD 0.01UF 100V CERAMIC 331-334, C134-139, 142-147, 213-220, 321, 327, 328.
2040-0002	CAP-FXD 0.1UF 25V CERAMIC C140, 141, 219, 220, 325, 326, 329, 330
2100-0001	CAP-FXD 1UF 25V ELECT AL C310
2100-0004	CAP-FXD 35UF 25V ELECT AL C120, 127, 302, 303, 306, 307, 316, 318
2100-0006	CAP-FXD 100UF 25V ELECT AL C125, 126, 304, 305, 308, 319
2100-0007	CAP-FXD 200UF 25V ELECT AL C208, 209
3015-0000	SWITCH-PB, 2 STA-2P, P-P S101, 102
3015-0001	SWITCH-PB 4 STA(1 SPACE)-2P S103-106
3105-0000	SOCKET-IC 8 PIN ROUND
3105-0001	SOCKET-IC 14 PIN DIP
3120-0000	CONN-SINGLE CONTACT, .093 PIN
3150-0002	SPACER-PUSHBUTTON SW, DOGBONE
3400-0001	RELAY-1 FORM C K1
3480-0000	FUSE-1/8 AMP, 3AG

01700-30011
ANAL FREQ 3RD DIGIT

PART NO	DESCRIPTION
1015-3178	RES-FXD 178K 1% 1/8W MF R72
1015-3200	RES-FXD 200K 1% 1/8W MF R71
1015-3226	RES-FXD 226K 1% 1/8W MF R70
1015-3267	RES-FXD 267K 1% 1/8W MF R69
1015-3324	RES-FXD 324K 1% 1/8W MF R68
1015-3887	RES-FXD 887K 1% 1/8W MF R63
1015-4100	RES-FXD 1M 1% 1/8W MF R62
1100-3390	RES-FXD 390K 5% 1/4W R67
1100-3560	RES-FXD 560K 5% 1/4W R66
1100-3820	RES-FXD 820K 5% 1/4W R65
1100-4110	RES-FXD 1.1M 5% 1/4W R61
1100-4130	RES-FXD 1.3M 5% 1/4W R60
1100-4160	RES-FXD 1.6M 5% 1/4W R59, 64
1100-4200	RES-FXD 2M 5% 1/4W R58
1100-4270	RES-FXD 2.7M 5% 1/4W R57
1100-4390	RES-FXD 3.9M 5% 1/4W R56
1100-4820	RES-FXD 8.2M 5% 1/4W R55
3015-0004	SWITCH-PB, 10 STA-6P S11

01700-30012
OSC FREQ 2ND DIGIT

PART NO	DESCRIPTION
1005-2174	RES-FXD 17.4K 0.25% 1/8W R127, 136
1005-2196	RES-FXD 19.6K 0.25% 1/8W R126, 135
1005-2226	RES-FXD 22.6K 0.25% 1/8W R125, 134
1015-2261	RES-FXD 26.1K 1% 1/8W MF R124, 133
1015-2316	RES-FXD 31.6K 1% 1/8W MF R50
1015-2392	RES-FXD 39.2K 1% 1/8W MF R49
1015-2523	RES-FXD 52.3K 1% 1/8W MF R48
1015-2787	RES-FXD 78.7K 1% 1/8W MF R47
1015-3133	RES-FXD 113K 1% 1/8W MF R33
1015-3158	RES-FXD 158K 1% 1/8W MF R32, 46
1015-3200	RES-FXD 200K 1% 1/8W MF R31
1015-3267	RES-FXD 267K 1% 1/8W MF R30
1015-3402	RES-FXD 402K 1% 1/8W MF R29
1015-3806	RES-FXD 806K 1% 1/8W MF R28
1100-2100	RES-FXD 10K 5% 1/4W R45
1100-2120	RES-FXD 12K 5% 1/4W R44
1100-2150	RES-FXD 15K 5% 1/4W R43
1100-2160	RES-FXD 16K 5% 1/4W R42
1100-2180	RES-FXD 18K 5% 1/4W R41
1100-2220	RES-FXD 22K 5% 1/4W R40
1100-2330	RES-FXD 33K 5% 1/4W R39
1100-2510	RES-FXD 51K 5% 1/4W R38
1100-2820	RES-FXD 82K 5% 1/4W R37
3015-0004	SWITCH-PB, 10 STA-6P S10

01700-30013
OSC FREQ 3RD DIGIT

PART NO	DESCRIPTION
1015-3178	RES-FXD 178K 1% 1/8W MF R145, 154
1015-3200	RES-FXD 200K 1% 1/8W MF R144, 153
1015-3226	RES-FXD 226K 1% 1/8W MF R143, 152
1015-3267	RES-FXD 267K 1% 1/8W MF R142, 151
1015-3324	RES-FXD 324K 1% 1/8W MF R141, 150
1100-3390	RES-FXD 390K 5% 1/4W R140, 149
1100-3560	RES-FXD 560K 5% 1/4W R139, 148
1100-3820	RES-FXD 820K 5% 1/4W R138, 147
1100-4160	RES-FXD 1.6M 5% 1/4W R137, 146
3015-0003	SWITCH-PB, 10 STA-4P S14

01700-30015
RATIO SWITCH ASSEM :

PART NO	DESCRIPTION
1005-0475	RES-FXD 475 0.25% 1/8W MF R232
1005-0690	RES-FXD 690 0.25% 1/8W MF R226-231
1005-1102	RES-FXD 1.02K 0.25% 1/8W R219-225
1015-2681	RES-FXD 68.1K 1% 1/8W MF R233
1100-0360	RES-FXD 360 5% 1/4W R218
2100-0001	CAP-FXD 1UF 25V ELECT AL C312, 323
2100-0003	CAP-FXD 10UF 25V ELECT AL C313, 324
2100-0006	CAP-FXD 100UF 25V ELECT AL C314, 315
2100-0017	CAP-FXD 33UF 15V ELECT LO C325
2100-0018	CAP-FXD 100UF 25V ELEC LO C326
3010-0000	SWITCH-ROTARY, RATIO S2

**01710-30001
INPUT SWITCH ASSEMBLY**

PART NO	DESCRIPTION
1000-0001	RES-FXD 102 0 1% 1/8W R22
1000-0002	RES-FXD 953 0 1% 1/8W R11
1000-0003	RES-FXD 3.92K 0 1% 1/8W R12
1000-0004	RES-FXD 110 0 1% 1/8W MF R23
1005-0221	RES-FXD 221 0 25% 1/8W MF R18, 21
1005-0698	RES-FXD 698 0 25% 1/8W MF R17, 20
1005-1221	RES-FXD 2.21K 0 25% 1/8W MF R16, 19
1005-1324	RES-FXD 3.24K 0 25% 1/8W MF R4, 9
1005-1698	RES-FXD 6.98K 0 25% 1/8W MF R3, 8, 15
1007-2221	RES-FXD 22.1K 0 25% 1/2W MF R2, 7
1008-2698	RES-FXD 69.8K 0 25% 1W MF R1, 6
1015-1261	RES-FXD 2.61K 1% 1/8W MF R24
1015-4103	RES-FXD 1M 1% 1/8W MF R5, 10
1100-2560	RES-FXD 56K 5% 1/4W R13
1100-3910	RES-FXD 910K 5% 1/4W R14
2000-0005	CAP-FXD 5PF 10% 500V MICA C116, 118
2000-0012	CAP-FXD 12PF 5% 500V MICA
3010-0006	SWITCH ROTARY, INPUT 1710A S1

**01710-30003
ATTENUATOR ASSEMBLY**

PART NO	DESCRIPTION
01700-30018	PC-ASSY IM SIGNAL GENERATOR
01710-30002	ASSY-PC, BALANCED AMPLIFIER
01710-30004	ASSY, 0 1DB/STEP ATTENUATOR
01710-30005	ASSY, VERNIER ATTENUATOR
01710-30006	ASSY, 1DB/STEP ATTENUATOR
01710-30007	ASSY, 10DB/STEP ATTENUATOR

**01710-30008
ASSY-PC, PWR SUP, GEN**

PART NO	DESCRIPTION
0005-0001	TRANS-POWER 2N3055 NPN SI Q601, 602
0100-0012	IC-REGULATOR 723, DIP 14 PIN U1, 2
0200-0001	DIODE-RECT 1N4003 SI CR1-6
1015-0576	RES-FXD 576 1% 1/8W MF R611
1015-0649	RES-FXD 649 1% 1/8W MF R610
1015-1499	RES-FXD 4.99K 1% 1/8W MF R612, 613
1015-1715	RES-FXD 7.15K 1% 1/8W MF R606, 607
1015-2100	RES-FXD 10K 1% 1/8W MF R604, 609
1100-1330	RES-FXD 3.3K 5% 1/4W R603, 608
1110-3001	RES-FXD 1 OHM 5% 1/2W R601, 605
1410-0002	RES-VAR 500 TRIMPOT CERMET R602, 614
2000-0100	CAP-FXD 100PF 5% 500V MICA C604, 609
2020-0000	CAP-FXD 0.01UF 10% 100V MYLAR C602, 607
2100-0004	CAP-FXD 35UF 25V ELECT AL C603, 608
2100-0010	CAP-FXD 3000-4200UF 40-50V EL C601, 606
2100-0021	CAP-FXD 100UF ELECT TANT AXL C605, 610

**01710-30009
PWR SUP, ANALYZER**

PART NO	DESCRIPTION
0005-0001	TRANS-POWER 2N3055 NPN SI Q601, 602
0100-0012	IC-REGULATOR 723, DIP 14 PIN U1, 2
0200-0001	DIODE-RECT 1N4003 SI CR601-612
1015-1150	RES-FXD 1.5K 1% 1/8W MF R612
1015-1162	RES-FXD 1.62K 1% 1/8W MF R606
1015-1422	RES-FXD 4.22K 1% 1/8W MF R604, 610
1015-1464	RES-FXD 4.64K 1% 1/8W MF R602, 609
1015-2158	RES-FXD 15.8K 1% 1/8W MF R613
1015-2200	RES-FXD 20.0K 1% 1/8W MF R607
1100-1220	RES-FXD 2.2K 5% 1/4W R605, 611
1110-4001	RES-FXD 6.2 5% 1W CARBON R608
1200-1000	RES-FXD 5 2W WW R601
1410-0002	RES-VAR 500 TRIMPOT CERMET R603, 614
2000-0100	CAP-FXD 100PF 5% 500V MICA C604, 609
2020-0000	CAP-FXD 0.01UF 10% 100V MYLAR C602, 607
2100-0004	CAP-FXD 35UF 25V ELECT AL C603, 605, 608
2100-0006	CAP-FXD 100UF 25V ELECT AL C610
2100-0009	CAP-FXD 1800-2500UF 40-50V EL C601, 606

**01710-30010
30KHZ FILTER**

PART NO	DESCRIPTION
0100-0014	IC-OP AMP 2605 GRADE 6 BLUE U1
1015-1487	RES-FXD 4.87K 1% 1/8W MF R1-3
2025-0012	CAP-FXD .0015UF 2.5% 63V PYSTR C1
2025-0014	CAP-FXD .0033UF 2.5% 63V PYSTR C2
2025-0021	CAP-FXD 220PF 1% 63V PLYSTR C4
2025-0022	CAP-FXD 560PF 1% 63V PLYSTR C3
2040-0000	CAP-FXD 0.01UF 100V CERAMIC C5, 6

**01710-30012
ASSY, METER SELECT**

PART NO	DESCRIPTION
1100-0010	RES-FXD 10 5% 1/4W R3-6
2040-0000	CAP-FXD 0.01UF 100V CERAMIC
3015-0010	SWITCH-PB, 10PDT P-P ORN IND. S3

**01710-30002
ASSY-PC, BALANCED AMPL**

PART NO	DESCRIPTION
0000-0002	TRANS-2N2905A PNP SI Q1, 4, 5, 8
0005-0006	TRANS-2N2219A NPN SI Q2, 3, 6, 7
0100-0007	IC-OP AMP 2605 GRADE 2 RED U1, 2
0200-0000	DIODE-GEN 1N914A SI CR3-8, 11-16
0200-0000	DIODE-GEN 1N914A SI CR17
0205-0003	DIODE-ZENER 1N749A 4.3V CR1, 2, 9, 10
0205-0005	DIODE-ZENER 1N4744 15V 10% CR17-20
1005-1232	RES-FXD 2.32K 1/8W .25% MF R13, 25
1005-1442	RES-FXD 4.42K 0.25% 1/8W MF R24
1005-1562	RES-FXD 5.62K 0.25% 1/8W MF R11
1005-2100	RES-FXD 10K 0.25% 1/8W MF R1, 14
1100-0002	RES-FXD 2.7 5% 1/4W R6, 10, 19, 23
1100-0010	RES-FXD 10 5% 1/4W R27, 28
1100-0015	RES-FXD 15 5% 1/4W R5, 9, 18, 22
1100-0560	RES-FXD 560 5% 1/4W R4, 8, 17, 21
1100-1180	RES-FXD 1.8K 5% 1/4W R2, 7, 15, 20
1100-2180	RES-FXD 18K 5% 1/4W R3, 16
1410-0011	RES-VAR 200 TRIMPOT CERMET R12
2000-0010	CAP-FXD 10PF 5% 500V MICA C7
2000-0056	CAP-FXD 56PF 5% 500V MICA C1, 6
2000-0100	CAP-FXD 100PF 5% 500V MICA C8, 9
2040-0002	CAP-FXD 0.1UF 25V CERAMIC C2-5
2040-0002	CAP-FXD 0.1UF 25V CERAMIC C10
3105-0000	SOCKET-IC 8 PIN ROUND
3260-0000	COIL-FXD 2.2UH L1, 2
3400-0000	RELAY-2 FORM C K1

**01710-30004
ASSY, 0.1DB/STEP ATTEN**

PART NO	DESCRIPTION
1015-0127	RES-FXD 127, 1% 1/8W MF R1, 2
1015-0130	RES-FXD 130, 1% 1/8W MF R3, 4
1015-0133	RES-FXD 133, 1% 1/8W MF R5-7
1015-0137	RES-FXD 137, 1% 1/8W MF R8, 9
3010-0007	SWITCH-ROTARY 1710 .1DB STEP S1

**01710-30005
ASSY, VERNIER ATTEN**

PART NO	DESCRIPTION
1015-1427	RES-FXD 4.27K 1% 1/8W MF R11
1400-0014	RES-VAR 1K 10% CARBON TYPE W R10
1410-0012	RES-VAR 20K TRIMPOT, STANDUP R12

**01710-30006
ASSY, 1DB/STEP ATTEN**

PART NO	DESCRIPTION
1005-0016	RES-FXD 16.9, 0.25% 1/8W MF R25
1005-0024	RES-FXD 24.3, 0.25% 1/8W MF R27
1005-0027	RES-FXD 27.1, 0.25% 1/8W MF R23
1005-0043	RES-FXD 43.7, 0.25% 1/8W MF R29
1005-0061	RES-FXD 61.9, 0.25% 1/8W MF R21
1005-0071	RES-FXD 71.5, 0.25% 1/8W MF R31
1005-0113	RES-FXD 113, 0.25% 1/8W MF R30
1005-0126	RES-FXD 126, 0.25% 1/8W MF R28
1005-0130	RES-FXD 130, 0.25% 1/8W MF R19
1005-0142	RES-FXD 142, 0.25% 1/8W MF R26
1005-0158	RES-FXD 158, 0.25% 1/8W MF R24
1005-0178	RES-FXD 178, 0.25% 1/8W MF R22
1005-0200	RES-FXD 200, 0.25% 1/8W MF R20
1005-0223	RES-FXD 223, 0.25% 1/8W MF R18
1005-0243	RES-FXD 243, 0.25% 1/8W MF R17
1005-0252	RES-FXD 252, 0.25% 1/8W MF R16
1005-0280	RES-FXD 280, 0.25% 1/8W MF R14
1005-0417	RES-FXD 417, 0.25% 1/8W MF R15
1005-0665	RES-FXD 665, 0.25% 1/8W MF R13
1005-0920	RES-FXD 920, 0.25% 1/8W MF R32
3010-0008	SWITCH-ROTARY 1710 1DB STEP S2

**01710-30007
ASSY, 10DB/STEP ATTEN**

PART NO	DESCRIPTION
1000-0015	RES-FXD 106.7, 0.1% 1/8W MF R35, 38
1000-0016	RES-FXD 1185, 0.1% 1/8W MF R59, 62
1000-0018	RES-FXD 371.3, 0.1% 1/8W MF R41, 44, 47, 50, 53, 56
1000-0019	RES-FXD 79.90, 0.1% 1/4W MF R57, 58, 60, 61
1000-0020	RES-FXD 91.65, 0.1% 1/4W MF R39, 40, 42, 43, 45, 46, 48, 49, 51, 52, 54, 55
1000-0021	RES-FXD 144.4, 0.1% 1/4W MF R33, 34, 36, 37
1000-0022	RES-FXD 150.0, 0.1% 1/4W MF R63-66
1015-1681	RES-FXD 6.81K 1% 1/8W MF R67, 68
3010-0009	SWITCH-ROTARY 1710 10DB STEP S3

APPENDIX A

USER'S MANUAL

MODEL 1710A OPTION 003

AUTOMATIC LEVEL SET

Specifications

Model 1700B specifications apply with the following additions:

Capture Range: 10 dB. INPUT switch must be set for meter reading in upper 2/3 scale in VOLTS/POWER function.

Harmonic Accuracy: Add to 1700B specification

Fundamental Frequency	2nd through 5th Harmonic Accuracy
10 Hz - 20 kHz	$\pm .2$ dB
20.1 kHz - 50 kHz	$\pm .5$ dB
50.1 kHz - 110 kHz	± 1 dB

Noise: (worst case with 80 kHz filter in) .007% to 20 kHz with the measured signal greater than 0.3 vrms. Noise decreases to the standard 1700B specification as input voltage approaches full scale. Automatic Set Level can be disabled to reduce noise for high resolution readings.

OPERATING INSTRUCTIONS

- a. Complete normal signal connections to the device under test as described in Section I of the Model 1710A User's Manual.
- b. Rotate the ADJUST control fully counter-clockwise, past the CAL position until a "click" is heard. This activates the auto set level circuitry.
- c. Press the VOLTS/POWER pushbutton and adjust the INPUT range switch so that a voltage (or power) reading is obtained with the meter pointer in the upper two-thirds of the meter scale.

NOTE

Levels less than one-third and much greater than full scale will cause errors in distortion readings.

- d. Press THD (distortion) pushbutton and take the distortion reading in the normal manner.

NOTE

1. The OVERLOAD indicator will glow whenever the VOLTS/POWER meter is being overloaded by more than 10 percent during distortion measurements. This is meant to inform the operator to up-range (advance the INPUT switch) while monitoring the distortion figure.

2. It is normal for the residual noise to increase slightly with the Auto Set Level circuit in operation. The error in distortion reading due to this figure is, in general, insignificant when the distortion figure is 0.02 percent or greater.

PRINCIPLES OF OPERATION

The signal input to the Notch Filter (or the variable output of Buffer) is fed to the AC to DC Converter (U1, U2). The DC signal out of this converter, which is directly proportional to the Notch Filter input signal level, is in turn driving a Voltage to Current Converter (U3), which regulates the controlling current to the Multiplier. The Multiplier is used as a variable gain amplifier (gain range from 1 to 3.16). Its gain is inversely proportional to the controlling current and the magnitude of the AC signal to the Notch Filter.

In the manual distortion-measurement mode, whenever the input signal is below full-scale (but more than 1/3 on VOLTS scale), Buffer Amplifier gain has to be increased with the use of the ADJUST control to make up for the lower amplitude. In the automatic mode, the distortion signal level is increased to exactly the required amount through the Multiplier before it goes to the AC meter. The net effect is the same as increasing the Buffer Amplifier gain, and the distortion readings obtained in this manner will always be accurate.

Since the Multiplier is processing signals after the Notch Filter, it is not adding distortion to the signal being analyzed. As a matter of fact, this scheme actually reduces the residual distortion noticeably above 50 kHz when the input signal is significantly below full-scale. However, there is some degradation of signal-to-noise ratio whenever the Notch Filter is operating with a smaller signal.

PERFORMANCE CHECK

- a. Connect cable between GENERATOR OUTPUT BALANCED terminals and INPUT BRIDGING terminals.
- b. Set Model 1710A controls as follows:

INPUT switch -----	1 V
ADJUST control -----	CAL
VOLTS POWER pushbutton -----	in
FAST RESPONSE/LOW DISTORTION switch ---	FAST RESPONSE
FREQUENCY pushbuttons -----	x100 } 1 kHz
	10 }
FILTER pushbuttons -----	NOISE; 80 kHz in
GENERATOR OFF switch -----	out

- c. Adjust GENERATOR LEVEL controls for 0.95 V rms, as indicated on meter.
- d. Press SET LEVEL pushbutton and rotate ADJUST control until meter pointer is exactly over SET LEVEL mark.
- e. Press THD pushbutton and set RATIO switch to proper range (.03% or .1%) to obtain a good reading (meter pointer in upper two-thirds of scale). Note this distortion reading.
- f. Now rotate ADJUST control counter-clockwise until a "click" is heard (AUTO position).
- g. Note distortion reading on meter. This should be the same as the one noted in step e, with an error no greater than 2 minor divisions on the 0-1 scale.
- h. Change INPUT switch to 3 V range (set level is now reduced by 10 dB) and note distortion reading on meter. This reading should be the same as the one noted in step e, with an error no greater than 2 minor divisions on the 0-1 scale. (Low Level light may or may not come on.)
- i. Set FREQUENCY pushbuttons to x1000, 100 (100 kHz) and adjust GENERATOR LEVEL controls for a 3 V rms reading on meter.
- j. Release NOISE filter pushbutton and manually adjust SET LEVEL control to obtain a distortion reading. Note this reading on dB meter scale.
- k. Rotate ADJUST control counter-clockwise to AUTO position. Note distortion reading on dB meter scale. Check that this reading agrees with the one obtained in step j, within 1 dB.

NOTE

It is normal for the distortion reading to drop when the input signal is reduced 10 dB below set level mark at 100 kHz. This is because the residual distortion of the analyzer has been greatly reduced with the decrease in input level at 100 kHz. (This is a bonus benefit from the Auto Set Level Option.)

- l. Press VOLTS/POWER pushbutton, change INPUT switch to 1 V, and set oscillator frequency to x100, 10 (1 kHz).
- m. Decrease generator level rapidly until the OVERLOAD indicator is extinguished. Now increase generator level very slowly until OVERLOAD indicator just begins to glow. (Vary generator level up and down, if necessary, to find the point at which the indicator just starts to glow.)
- n. Change INPUT switch to 3 V position and note meter reading. Meter pointer should be between -9.5 and 8.5 on dB scale (106 and 118 on the 0.3 V scale).

CALIBRATION PROCEDURE

- a. Center all four trimpots (excluding R6) on Auto Set Level P.C. board and turn power on.
- b. Set Model 1710A controls as follows:

ANALYZER SELECT switch -----	GENERATOR OUTPUT
INPUT switch -----	100
SET LEVEL pushbutton -----	in
ADJUST control -----	CAL
RATIO switch -----	0 dB (100%)
FILTER pushbuttons -----	both out
FREQUENCY pushbuttons -----	x100 } = 1 kHz
	10 }
FAST RESPONSE/LOW DISTORTION -----	FAST RESPONSE
GENERATOR OFF switch -----	in

Measure dc voltage at (+) terminal of C7 (10 microfarads) with respect to ground (-) terminal of C15. Adjust zero trimpot R21 for zero volts dc ± 1 mV.

- c. Change INPUT switch to 1 V and release GENERATOR OFF switch. Adjust GENERATOR LEVEL controls until meter pointer indicates full scale.
- d. Press dB VOLTS pushbutton and note exact position of meter pointer on 0 to 1 scale.
- e. Set ADJUST control to AUTO position.
- f. Measure dc voltage at normally-closed (NC) contact of relay K1 (as shown in parts location diagram) with respect to ground (negative terminal of C15). Adjust zero trimpot R20 for zero volts dc ± 5 mV.
- g. With INPUT switch in 1V position, adjust F.S. trimpot R7 for the same pointer position noted in step d.
- h. Change INPUT switch to 3 V and adjust offset trimpot R14 for the same pointer position noted in step g.
- i. Repeat steps g and h until meter pointer rests on the same mark, $\pm 0.1\%$ of full scale (\pm one line width).

TROUBLESHOOTING

The Auto-Set-Level circuit is an open-loop type, so straight-forward signal tracing techniques can be used to locate defective parts. The entire circuit block is always active, even in the manual mode.

With full-scale output at the Buffer Amplifier, the Multiplier should have unity gain. With .316 of full-scale Buffer output, the Multiplier gain should change to 3.16.

OPTION 003 -
 AUTO SET LEVEL:
 AUTO SET LEVEL
 PCB ASSY: 01700-30016

CKT REF S-T P/N

C1-2 2100-0006
 C3 2040-0000
 C4 2000-0056
 C6 2040-0000
 C7 2100-0003
 C8 2040-0000
 C9 2000-0056
 C11-13 2040-0000
 C14 2000-0100
 C15 2100-0001
 C16 2100-0006
 C18-19 2040-0002
 C20 2040-0000
 C21 2000-0056
 C22-23 2040-0000

CR1-2 0200-0000
 CR3 (004) 0200-0000
 CR4-6 0200-0000

K1 3400-0001
 K2 (004) 3400-0001

R1-3 1015-2100
 R4 1015-1499
 R5 1015-2133
 R6 (004) 1410-0018
 R7 1410-0018
 R8 1015-2147
 R9 1100-2270
 R10 1100-2150
 R11 1100-1470
 R12 1100-3470
 R13 1015-4100
 R14 1410-0018
 R15 1015-1715
 R16 1015-1232
 R18-19 1100-1100
 R20-21 1410-0018
 R22 1015-2261
 R23 1015-2162
 R24 1100-0750
 R25 1015-1100
 R26 1410-0016
 R27 1015-2681
 R28 1015-2100

U1 0100-0010
 U2-3 0100-0001
 U4 0100-0015
 U5 0100-0014

COMPONENT PARTS LIST
 OPT 003 - AUTO SET LEVEL

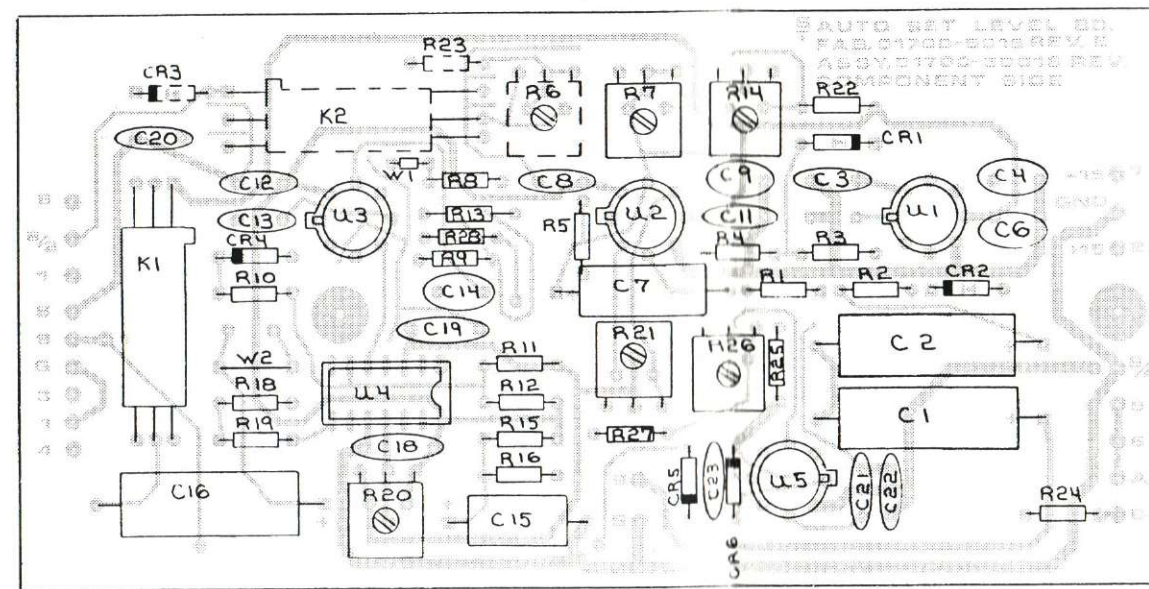
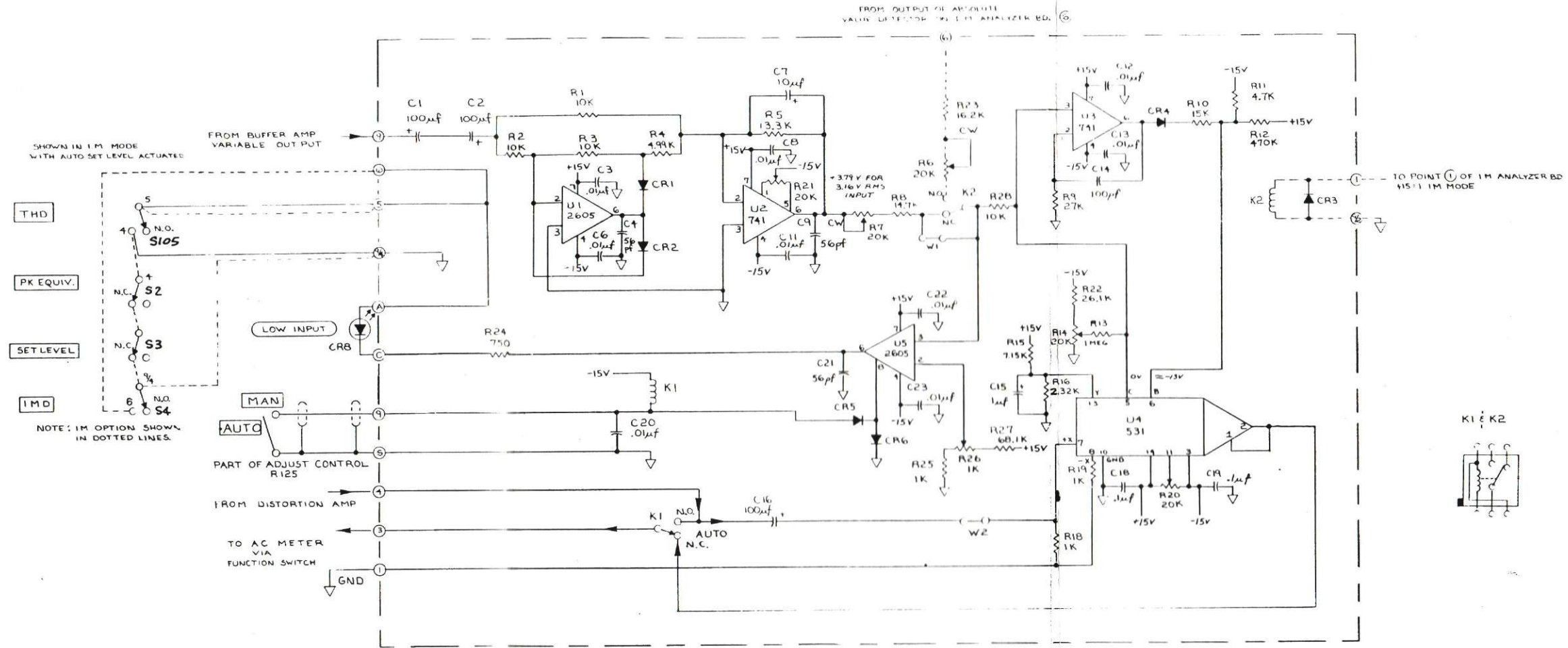

COMPONENT LOCATOR
 OPTION 003
 AUTOMATIC SET LEVEL

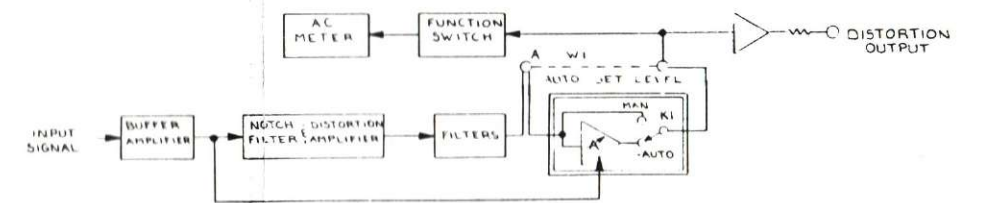

SCHEMATIC DIAGRAM
 OPTION 003
 AUTOMATIC SET LEVEL

APPENDIX B

USER'S MANUAL

SOUND TECHNOLOGY

MODEL 1710A OPTION 004

INTERMODULATION DISTORTION ANALYZER

CONTENTS

SECTION I - OPERATION

1-1.	Measurement Technique.	B1-1
1-2.	IMD Option	B1-1
1-3.	Controls and Indicators.	B1-1
1-4.	Operating Instructions	B1-2
1-5.	Test Set-Up.	B1-2
1-6.	IM Distortion Measurement with 4:1 or 1:1 LF:HF Amplitude Ratio. .	B1-2
1-7.	IM Distortion Measurement with Non-Standard LF:HF Amplitude Ratio.	B1-3
1-8.	IM Distortion Measurements with Auto Set Level	B1-3

SECTION II - PRINCIPLES OF OPERATION

2-1.	Introduction	B2-1
2-2.	IM Signal Source	B2-1
2-3.	IM Analyzer.	B2-1

SECTION III - MAINTENANCE

3-1.	Introduction	B3-1
3-2.	Test Equipment	B3-1
3-3.	Performance Check.	B3-1
3-4.	Introduction	B3-1
3-5.	Intermodulation Residual Distortion Test	B3-1
3-6.	Adjustment and Calibration Procedure	B3-2
3-7.	Oscillator Adjustments	B3-2
3-8.	4:1 Divider Confidence Check	B3-2
3-9.	Peak Detector and THD Signal Level Adjustments	B3-4
3-10.	Absolute Value Detector Offset Null.	B3-4
3-11.	IMD Measurement Calibration.	B3-4
3-12.	Auto Set Level Adjustmt.	B3-5
3-13.	Troubleshooting.	B3-5
3-14.	Symptom/Cause Table.	B3-6
3-15.	Component Replacement-Calibration and Adjustment	B3-6
3-16.	Access to Low-Distortion Oscillator.	B3-6
3-17.	Modifications for Europe and Japan	B3-7
3-18.	DIN (Europe)	B3-7
3-19.	50/60 Hz Operation (Japan)	B3-7

SECTION IV - DIAGRAMS

4-1.	Introduction	B4-1
4-2.	Schematic Diagrams	B4-1
4-3.	Component Location Diagrams.	B4-1

SECTION V - SPARE PARTS

5-1.	Introduction	
5-2.	Ordering Information	

Specifications

MEASUREMENT SECTION

All 1700B specifications and performance features are retained with the following additions.

Intermodulation Distortion Ranges: 0.01% to 100% full scale in 9 ranges.

Residual Intermodulation Distortion and Noise: < 0.0025% with internal generators set at 4:1 for input signals greater than 0.3V (10 mw across 8Ω). < 0.004% for input signals 0.1V to 0.3V.

Intermodulation Distortion Accuracy: $\pm 2\%$ full scale.

Peak Equivalent Single Tone RMS Voltage Accuracy: $\pm 2\%$ full scale.

GENERATOR SECTION

Output attenuator and vernier control the single tone sine-wave oscillator output as well as the intermodulation distortion generator output. All 1700B oscillator specifications apply except output level control is via the attenuator and output impedance is 600Ω .

Output Voltage: 1mV to 3V open circuit, peak equivalent single tone RMS.

Output Attenuator: 70 dB in 10 dB steps, accurate within ± 0.1 dB.

Output Vernier: > 10 dB range, continuously adjustable.

Output Impedance: $600\Omega \pm 1\%$.

Low Frequency Generator: 50 or 60 Hz synchronized with power line. Total Harmonic Distortion < 0.1%.

High Frequency Generator: 7 kHz $\pm 1\%$.

LF/HF Ratio: Switch selectable 4:1 $\pm 1\%$ or 1:1 $\pm 2\%$. Continuously variable from 1:1 to > 100:1 with HF amplitude control.

GENERAL

Weight: Adds 5 lbs. to 1700B weight.

SECTION I - OPERATION

This Appendix provides operating and service information for the Model 1710A Intermodulation Distortion (IMD) Analyzer Option G04. The information contained in the Appendix pertains to the IMD option only. Consult the Model 1710A manual for additional information regarding primary power requirements, grounding details, and cabling instructions.

1-1. MEASUREMENT TECHNIQUE

The IMD option is based on the SMPTE (Society of Motion Picture and Television Engineers) method to measure IMD whereby a large 60-Hz signal is combined with a small 7 kHz signal in a four-to-one amplitude ratio. Passing this combined (composite) signal through a non-linear device results in the appearance of new frequencies above and below 7 kHz in multiples of 60 Hz. The effect of these new frequencies is amplitude modulation of the 7 kHz signal, which can be detected.

The component parts of the IMD option include a signal source and an IM analyzer. The signal source generates a low-frequency sinusoid and a high-frequency sinusoid that are mixed and fed to the input of the device under test. Level controls are provided so that the amplitude of the composite signal can be set to the desired level. The signal from the output of the device under test is then fed back to the analyzer circuits of the IMD meter. A high-pass filter removes the low frequency, leaving only the high frequency together with any possible low-frequency modulation. This signal is input to an envelope detector (or absolute value detector) resulting in only the rectified carrier with its amplitude varying at a low-frequency rate. A low-pass filter removes the carrier, leaving only the modulation products. The amount of these products is indicated on the meter in terms of percentage of the high frequency signal passed through the high-pass filter.

1-2. IMD OPTION

This option adds IMD measurement capability to the Model 1710A Distortion Measurement System. It employs the IMD measurement technique described above and in addition provides the user with a number of unique operating features. These are detailed in the following paragraphs.

The IM signal source contains a 60 Hz low-frequency oscillator and a 7 kHz high frequency oscillator. Controls on the front panel permit a rapid selection of a composite test signal having fixed low-frequency to high-frequency ratios of 4:1 or 1:1 plus a variable ratio of greater than 16:1 to 1:1. The amplitude of the test signal is controlled by the attenuators as described in Section 1-7e. The amplitude of the composite test signal can be measured directly in peak equivalent rms single tone voltage or power. This parameter, specified by the Institute of High Fidelity for IMD measurements, is defined as the voltage or power level of a sine-wave signal having a peak value equal to the peak value of the composite IM test signal. The ability to make this measurement eliminates the need for meter reading conversion or matching oscilloscope waveforms.

IMD option combines with the Model 1710A input circuits to provide the option with a differential input configuration. In operation, the IM analyzer is capable of measuring IMD with a residual intermodulation distortion of less than .0025 percent. Meter sensitivity ranges from 100 percent to .01 percent full scale. The analyzer can also measure the LF-to-HF voltage ratio of the IM test signal from (a) input to the device under test or (b) output from the device to the analyzer. When the analyzer is used with a Model 1710A fitted with Auto Set Level (Option 003) it is possible to perform IMD testing without adjusting the SET LEVEL control. This feature facilitates testing volume compressors/expanders and similar non-linear devices. Operation with the Auto Set Level option also permits the user to switch from Total Harmonic Distortion (THD) testing to IMD testing without having to make adjustments to compensate for the frequency response of the device under test.

1-3. CONTROLS and INDICATORS

The data sheet at the front of the 1710A manual describes the controls and indicators on the front panel of the Model 1710A IMD option. The following provides additional explanatory information.

- a. OFF pushbutton -- Switches system measurement mode from intermodulation distortion (IMD) to total harmonic distortion (THD). System is in THD mode when pushbutton is in.

- b. PK EQUIV V/PWR pushbutton -- Selects measurement mode whereby meter displays amplitude of IM test signal in peak equivalent rms single tone voltage or power.
- c. GENERATOR LEVEL controls -- Varies level of IM test signal.
- d. VERNIER control -- Varies level of IM test signal over a ± 1 dB range.
- e. RATIO slide switch -- Selects desired low-frequency to high-frequency amplitude ratio of composite IM test signal. Two fixed ratios (4:1) and (1:1) are available. The VAR (variable) position allows selection of a ratio variable from greater than 16:1 to 1:1 with adjacent HF AMPL control.
- f. HF AMPL control -- Adjusts LF:HF ratio of composite IM test signal when RATIO slide switch is set to VAR position. MAX setting (fully clockwise) selects a 1:1 ratio.
- g. HF ONLY pushbutton -- Turns off low-frequency oscillator. When pushbutton is in, only the high-frequency signal is present at GENERATOR OUTPUT.
- h. LF ONLY pushbutton -- Turns off high-frequency oscillator. When pushbutton is in, only the low-frequency signal is present at the output.
- i. SET LEVEL pushbutton -- Selects set level function whereby meter displays amplitude of reference high-frequency signal required for IMD measurement.
- j. ADJUST control -- Adjusts amplitude of reference signal for IMD measurement.
- k. ERROR indicator -- Lights during Auto Set Level operation when adjacent ADJUST control is incorrectly set. Correct setting is achieved by turning ADJUST control until indicator is extinguished. Light will also go out if composite input signal is either below 20% or greater than 150% of full scale.
- l. IMD pushbutton -- Selects intermodulation distortion measurement function.
- m. IM indicator -- Lights when system is in IMD measurement mode i.e., whenever PK EQUIV V/PWR, SET LEVEL, or IMD pushbutton is in and HF ONLY and LF ONLY pushbuttons are out.
- n. IMD SYNC connector -- Provides oscilloscope sync for long distance IMD measurements.

1-4. OPERATING INSTRUCTIONS

1-5. TEST SET-UP

Refer to Section I of the Model 1710A manual and connect the equipment as shown in Figure 1-1. Also, read and follow the instructions given in paragraphs 1-11 through 1-15 of the same manual before making any IMD measurements. Sync the test oscilloscope to the line frequency and set sweep speed to 5 msec/div.

1-6. IM DISTORTION MEASUREMENT WITH 4:1 OR 1:1 LF:HF AMPLITUDE RATIO.

To measure intermodulation distortion with a 4:1 LF:HF composite signal, proceed as follows:

- a. Set Model 1710A ADJUST control to CAL position or AUTO (for auto set level).
- b. Set IM RATIO switch to 4:1
- c. Press PK EQUIV V/PWR pushbutton.
- d. Ensure that HF ONLY and LF ONLY pushbuttons are in the out position.
- e. Set Model 1710A INPUT switch to desired range setting. Adjust GENERATOR LEVEL switches and VERNIER control for desired rms peak equivalent single tone voltage/power reading. Ensure that meter indication is in upper two-thirds of scale.
- f. Push IM SET LEVEL pushbutton and turn adjacent ADJUST control until meter reads full scale. Omit this step if using auto set level.

- g. Push IMD pushbutton. Adjust Model 1710A RATIO switch until meter deflection is in upper two-thirds of scale, if possible.
- h. Read distortion in either percent or dB as indicated by meter deflection and RATIO switch range setting. For example, if meter reads .67 and RATIO range is 0.1 PERCENT, distortion reading is .067%.
- i. To switch the 1710A to the THD mode, push the OFF pushbutton on the IM panel.

NOTE

It is normal for the 1710A oscillator to go through a few cycles of stabilization when switching from the IMD mode to the THD mode. This is due to the power supply for the main oscillator being turned off when in the IMD mode.

To make an IM distortion reading with a 1:1 LF:HF signal, set the IM RATIO switch to 1:1 and then carry out steps c. through i. above.

1-7. IM DISTORTION MEASUREMENT WITH NON-STANDARD LF:HF AMPLITUDE RATIO

To perform an IM distortion measurement using a LF:HF amplitude ratio other than 4:1 or 1:1, proceed as follows:

- a. Set Model 1710A ADJUST control to CAL position or AUTO (for auto set level).
- b. Set IMD option controls as follows:

PK EQUIV V/PWR pushbutton		IN
IM RATIO switch		VAR
LF ONLY pushbutton		IN
HF ONLY pushbutton		OUT
ANALYZER SELECT		INPUT or GENERATOR OUTPUT AS DESIRED
- c. Adjust Model 1710A INPUT switch, and GENERATOR LEVEL and VERNIER controls for a full-scale reading on an appropriate meter voltage scale.
- d. Calculate inverse of desired LF:HF ratio. For example if desired ratio is 16:1, inverse would be 1.0 to 0.0625 LF:HF.
- e. Set LF ONLY button to out position and press HF ONLY pushbutton. Now adjust HF AMPL control until meter indicates relative high-frequency level determined in step d. For example, for a 16:1 ratio, the HF AMPL control should be adjusted to obtain a meter reading of .0625 of full scale. The INPUT switch can be stepped down to obtain a more accurate reading of the high-frequency signal. For the 16:1 ratio, the INPUT switch can be stepped down two positions, adjusting the meter reading to .625 on the 0-1.0 meter scale.
- f. Now set HF ONLY pushbutton to out position and follow steps c. through i. of paragraph 1-6.

1-8. IM DISTORTION MEASUREMENTS WITH AUTO SET LEVEL

To make an IM distortion measurement using a Model 1710A fitted with the Auto Set Level option proceed as follows:

- a. Turn Model 1710A ADJUST control fully counter-clockwise past CAL position until detent position is reached. This activates the Auto Set Level circuit. The gain of the intermodulation analyzer must be within a certain range for the Auto Set Level to function correctly. The ERROR indicator lights whenever the intermodulation analyzer gain is not within the necessary gain "window". In this event, turn the IM ADJUST control until the ERROR indicator is extinguished.
- b. Follow steps described in paragraph 1-6.
- c. Observe ERROR indicator; rotate IM ADJUST control until an off "window" is found; then set the IM ADJUST control to the window's approximate center.
- d. To switch the 1710A to the THD mode, push the OFF pushbutton on the IM panel. (It is normal for the 1710A oscillator to go through a few cycles of stabilization when switching from the IMD mode to the THD mode.)

SECTION II - PRINCIPLES OF OPERATION

2-1. INTRODUCTION

This section contains a functional description of the IM signal source and the IM analyzer - the principle components of the IMD option. For a description of the IMD measurement technique employed by the option and a description of its operating features, refer to Section I of this Appendix.

2-2. IM SIGNAL SOURCE

Refer to the schematic diagram in Section IV of this manual. The IM signal source consists of two Wien bridge RC oscillators, a summing amplifier, and an output attenuator. The low-frequency (LF) oscillator operates at 60 Hz and is synced to the line frequency. The oscillator has an output amplitude of 6.3 volts rms (nominal). The high-frequency (HF) oscillator operates at 7 kHz and also has an output of 6.3 volts rms (nominal). The HF oscillator is optimized for maximum amplitude stability. The signals from both oscillators are coupled to the input of a summing amplifier that supplies the composite IM test signal.

The amplitude ratio of the two frequencies is controlled by varying the amplitude of the HF signal input to the summing amplifier. When the front-panel RATIO slide switch is set to the 1:1 position, the full 6.3 volts rms (nominal) HF signal is delivered to the summing amplifier. When the RATIO slide switch is set to the 4:1 position, a resistive divider attenuates the HF signal by a factor of four, so that the HF level at the summing amplifier output is one-quarter that of the LF level. When the RATIO switch is set to VAR position, a potentiometer controlled by the front-panel HF AMPL knob permits the level of the HF input to the summing amplifier to be set to any level between zero and 6.3 volts rms.

To maintain the same peak equivalent level for both 4:1 and 1:1 fixed ratios, K3 and driver Q9 are used to change the gain of the summing amplifier. K3 is on for 1:1 and variable ratios and off for 4:1 ratio.

The IM signal source is operable only when the IMD OFF switch is set to the IM (out) position. This causes K1 to disconnect dc operating voltage to THD low-distortion oscillator and allows the 60-Hz and 7-kHz oscillators to turn on. When the IMD OFF switch is pressed, dc power is connected to the THD low-distortion oscillator and at the same time dc voltages are applied to the two IM oscillator circuits biasing them to an off state, through photocouplers U18, U19.

Dual form-C relay K1 on the balanced amplifier board selects either a low-distortion sine-wave or a composite IM test signal to be attenuated and amplified. Relay K3 on the IM analyzer board provides the drive to K1 during the IM mode.

2-3. IM ANALYZER

The following is a discussion of the IM analyzer board and Model 1710A circuits that comprise the IM analyzer. Refer to the schematic diagrams in the Model 1710A manual and Section IV of this manual for circuit details.

The IM test signal from the device under test is connected via the Model 1710A INPUT terminals to the INPUT attenuator and from there to the differential input buffer and differential-to-signal-ended buffer. The output signal from the buffer amplifier (in the range from 1 to 3.16 peak equivalent volts), is coupled via a passive 2-pole high-pass filter to the input buffer. The filter attenuates the 60 Hz component of the IM signal by approximately 26 dB. The gain of the input buffer is variable from 2 to 100 by the front panel IM ADJUST control. This allows the amplitude of the signal at the output of the IM buffer (TP1) to be set to approximately 3.16 volts, the correct set level for the IM distortion measurement.

From the IM input buffer, the signal is connected to an active 7-pole, high-pass filter having a cut-off frequency of 2 kHz. This attenuates the 60 Hz by a further 210 dB, leaving only a pure 7 kHz sine wave plus any amplitude modulation caused by the non-linearity of the device under test. From here, the signal is connected to an absolute value detector that rectifies the 7 kHz waveform.

When the IM SET LEVEL pushbutton is pressed, the output of the absolute value detector, which is essentially a dc level representing the amplitude of the 7 kHz component of the test waveform, is connected through switch S3 to the front panel meter. This permits monitoring the amplitude of the HF component of the input signal for Set-Level adjustments.

The output of the absolute value detector is also coupled to a 7-pole, low-pass filter with a cut-off frequency of 500 Hz. This removes the 7 kHz component from the rectified signal, leaving only the intermodulation products. The output from the low-pass filter is connected to the THD RATIO attenuator and distortion amplifier through OFF switch, S1. The amplifier output is 31.6 mV full scale for each attenuator setting.

An IM measurement is made by pressing the IMD pushbutton, connecting the distortion amplifier output via the auto set level option and the IM meter amplifier to the front panel meter. If the auto set level option is not fitted, the signal is jumpered directly from the distortion amplifier to the IM meter amplifier. Also, when the system is in the IM measurement mode, a relay bypasses the HUM and NOISE filters located between the distortion amplifier output and the input of the auto set level circuit. This relay is on the THD analyzer board and activated through a contact on relay K1, located on the IM analyzer board.

When the PK EQUIV V/PWR pushbutton switch S2 is pressed, the output of the THD meter preamplifier is connected via the IM peak detector to the front-panel meter. The THD meter preamplifier has a 31.6 mV full scale output on each range of the INPUT attenuator and the peak detector buffer has a gain of approximately 22. This changes the 31.6 mV full scale signal to approximately one volt peak at the peak detector input and causes one milliampere of current to be supplied to the meter for a full scale reading.

The peak detector, consisting of U9 and associated components, operates as a summing amplifier. The input to the circuit may be considered to be at the junction of capacitor C46 and resistor R36. The detector responds to negative input peaks. Meter current (average one milliampere full-scale) flows back to the summing point through resistor R38. If the peak negative input current through R36 exceeds the feedback current, the output of U9 will go positive and add charge to C55 through emitter-follower Q1. This added charge will then increase the average meter current: As long as the output of U9 swings positive each cycle, Q2 will conduct each cycle, thus holding down the voltage on C54 and preventing Q3 from conducting. If the peak input current does not exceed the feedback current, the output of U9 remains clamped negative by diode CR5 at approximately 0.7 volts. In this event, the voltage on C54 will rise, and Q3 will conduct to quickly reduce the charge on C55. This allows the meter to respond quickly to a decreasing signal level.

The Auto Set Level option provides automatically controlled gain at the output of the distortion amplifier to compensate for a 10 dB range of input signal. For THD measurements, gain is simply controlled by the input signal level, which is the reference for the measurement. For IMD measurements, the reference for the measurement is not the input signal (total composite signal) but rather the level of the high-frequency (7 kHz) component. Yet, the input signal level indicated on the front panel meter (PK EQUIV V/PWR) during the measurement is proportional to the peak value of the composite signal.

For the Auto Set Level to operate over a 10 dB range of peak equivalent volt-power level, it is necessary that the SET LEVEL control be adjusted such that when in the SET LEVEL mode, the meter reads within approximately plus or minus 2 dB of the meter deflection when in the PK EQUIV V/PWR mode. This places the output of the absolute level detector in the proper range to control the auto set level circuit. Once the SET LEVEL control is properly set, no further adjustment is required unless the low-to-high frequency ratio at the analyzer input is changed. Now, the 7 kHz level (absolute value detector output) tracks the input signal level (peak detector output).

In order to avoid possible readout error due to an incorrectly adjusted SET LEVEL control, a "window" detector is incorporated in the IM analyzer. This circuit consists primarily of operational amplifiers U14 and U15. U14 turns on ERROR light-emitting diode CR24 if the output of the absolute value detector, as divided down by resistors R68, R70 and R71, exceeds the output of the peak detector by approximately 2.5 dB. The peak detector output is derived from the voltage developed across resistor R38. Conversely, U15 turns on the ERROR indicator if the output of the peak detector exceeds the output of the absolute value detector, as divided down and appearing at pin 3 of U15, by approximately 2 dB.

Operational amplifiers U16 and U17 act in a similar manner to disable the ERROR indicator (by absorbing the drive current through R79) if the peak equivalent volt power reading is too low (less than 20 percent of full scale), or too high (greater than 150 percent of full scale). Here the peak detector output is simply compared to dc levels. Q4 is used to turn off the ERROR indicator when the instrument is not in the auto mode of operation. If the auto set-level option is not installed, R79 is removed.

The reader may be interested to know that in the U17/U18 comparator circuit, diode CR22 is a redundant component. If the output of U17 goes negative, it pulls the output of U16 negative through the pin 8 connections. Therefore CR22 may be used as a spare diode.

A constant amplitude sync signal for viewing the IM distortion products is provided by a combination of a 3-pole low-pass filter followed by clipping amplifier U20.

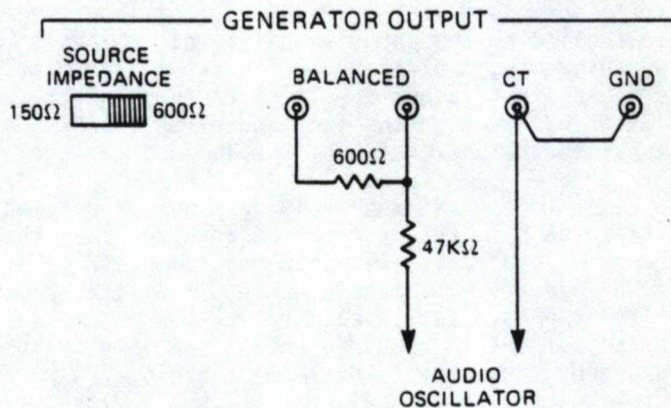

Figure 3-1. IMD Measurement Calibration Test Setup

SECTION III - MAINTENANCE

3-1. INTRODUCTION

This section provides a performance check, adjustment and calibration procedures, and troubleshooting information for the IMD option.

3-2. TEST EQUIPMENT

Recommended test equipment for performance checking and troubleshooting is listed in Table 3-1. Test instruments other than those described can be used provided their specifications equal or exceed those listed.

Table 3-1. Required Test Equipment

TYPE	REQUIRED SPECIFICATIONS	USE	RECOMMENDED INSTRUMENT
AC-DC DIGITAL VOLTMETER	Range: 1mV to 2V Accuracy: 0.1% ± 1 digit	Calibration	Fluke Model 8000A
Audio Generator	Frequency Range: to 8 kHz	Calibration	Sound Technology Model 1700B or 1400A
OSCILLOSCOPE	Bandwidth: 500 kHz Deflection Factor: 5 mV/div Number of Channels: 2	Calibration and Troubleshooting	Hewlett-Packard Model 1200A or Philips Model 3232

3-3. PERFORMANCE CHECK

3-4. INTRODUCTION

The performance check for the IMD option consists of an intermodulation residual distortion test. If the performance limits are exceeded in the following paragraph, refer to the troubleshooting hints in paragraph 3-13.

3-5. INTERMODULATION RESIDUAL DISTORTION TEST

a. Set controls as follows:

```

IM RATIO switch ----- 4:1
HF ONLY pushbutton ----- out
LF ONLY pushbutton ----- out
SOURCE IMPEDANCE switch ----- 600 Ω
    
```

- b. Connect a 600-ohm load resistor across GENERATOR OUTPUT BALANCED terminals and connect a shorting link between GENERATOR OUTPUT CT and GND terminals.
- c. Set Model 1710A ANALYZER SELECT/GENERATOR OUTPUT switch to GENERATOR OUTPUT and connect oscilloscope to INPUT and OUTPUT MONITOR jacks.
- d. Press PK EQUIV V/PWR pushbutton and set INPUT switch to 3V range. Adjust GENERATOR OUTPUT LEVEL controls for a full-scale reading on meter.
- e. Press IMD SET LEVEL pushbutton and rotate adjacent ADJUST control for a full-scale reading on meter.
- f. Press IMD pushbutton and set RATIO switch to -80 dB/.01 PERCENT range. Check that meter reading is .0025% or less.

3-6. ADJUSTMENT AND CALIBRATION PROCEDURE

This procedure should be performed whenever the results of the performance check (Paragraph 3-3) clearly establish the need to do so. After successfully performing in sequence the procedure in Paragraphs 3-7 through 3-12, the IMD option is considered to be calibrated.

NOTE

When performing this procedure ensure that only the equipment and cables specified are connected to the instrument.

3-7. OSCILLATOR ADJUSTMENTS

- a. Set front panel controls as follows:

PK EQUIV V/PWR pushbutton	-----	in
HF ONLY pushbutton	-----	out
LF ONLY Pushbutton	-----	in
RATIO switch	-----	1:1
GENERATOR OUTPUT VERNIER control	-----	max CW
GENERATOR OUTPUT switches	-----	+10, -2, 0
SOURCE IMPEDANCE switch	-----	600 Ω
FAST RESPONSE/LOW DISTORTION	-----	Fast Response
THD ADJUST control	-----	CAL

- b. Connect a 600-ohm resistor between GENERATOR OUTPUT BALANCED terminals and connect a shorting link between GENERATOR OUTPUT CT and GND terminals.
- c. (Ignore an indicated overload condition.) Remove sync from LF oscillator either by removing connection to power transformer (#7 on Generator Board) or by lifting one end of C19. Connect BALANCED output to a scope with horizontal sweep (5 ms/cm) synced to power line. Adjust R4 for a stationary pattern (LF oscillator running at line frequency). It may be necessary to adjust FET bias (R8) to keep oscillator running as R4 is adjusted. Restore LF oscillator sync.
- d. Set ANALYZER SELECT/GENERATOR OUTPUT switch to GENERATOR OUTPUT and LF ONLY pushbutton to out position.
- e. Measure Q6 gate voltage (an easy place to measure is at C11, .033 uf.). Allowable range is 1.0 to 2.0 Vdc. If out of range, adjust R23 for a reading 1.5 Vdc. Isolate gate voltage from voltmeter probe with a 10 K ohm resistor.
- f. Measure Q3 gate voltage (an easy place to measure is at collector of Q2. Don't forget 10 K isolation!). Allowable range is 1.0 to 2.0 Vdc. If out of range, adjust R8 for a reading of 1.5 Vdc.
- g. Press HF ONLY pushbutton. Adjust OUTPUT VERNIER control until front panel meter reads exactly full scale.
- h. Change front panel controls as follows:

HF ONLY pushbutton	-----	out
LF ONLY pushbutton	-----	in

- i. Without changing setting of OUTPUT VERNIER control, carefully adjust R13 until front panel meter indicates same full-scale reading obtained in Step c above.
- j. Repeat Step d above. If it was necessary to readjust R8, repeat Step g.

3-8. 4:1 DIVIDER CONFIDENCE CHECK

- a. Change front panel controls as follows:

INPUT switch	-----	3V
RATIO switch	-----	4:1

- b. Adjust OUTPUT VERNIER (and/or R44) for a front panel meter reading as close as possible to 2.40 Vac.
- c. Change front panel controls as follows:

HF ONLY pushbutton	-----	in
LF ONLY pushbutton	-----	out
INPUT switch	-----	1 V
- d. Check that front panel meter reads $0.60 \pm .02$ V.

3-9. PEAK DETECTOR AND THD SIGNAL LEVEL ADJUSTMENTS

- a. Connect DVM in parallel with 600-ohm load resistor connected across GENERATOR OUTPUT BALANCED terminals. Connect shorting link between GENERATOR OUTPUT GND terminal and one of the adjacent GENERATOR OUTPUT BALANCED terminals.
- b. Change front panel controls as follows:

HF ONLY pushbutton	-----	out
LF ONLY pushbutton	-----	in
- c. Adjust OUTPUT VERNIER and OUTPUT ATTEN controls (and/or R44) for DVM reading of 0.800 Vac.
- d. Change front panel controls as follows:

HF ONLY pushbutton	-----	out
LF ONLY pushbutton	-----	out
GENERATOR OUTPUT switches	-----	+10, -8
- e. Adjust R34 on IM analyzer board for an exact full-scale reading on front panel meter.
- f. Change front panel controls as follows:

IM	-----	off
FREQUENCY pushbuttons	-- x10 100	} = 1 kHz
- g. Adjust GENERATOR OUTPUT VERNIER control for an exact full scale reading. Press PV/EQUIV pushbutton and adjust R44 on IM analyzer board for an exact full scale reading.

3-10. ABSOLUTE VALUE DETECTOR OFFSET NULL

- a. Remove input signal and set INPUT switch to 3V.
- b. Connect DVM between TP4 and ground (negative end of C34).
- c. Set DVM to its most sensitive range.
- d. Adjust R22 for DVM reading of less than $\pm .003$ Vdc.

3-11. IMD MEASUREMENT CALIBRATION

- a. Connect a 600-ohm load resistor across GENERATOR OUTPUT BALANCED terminals and connect a shorting link between the GENERATOR OUTPUT CT and GND terminals.
- b. Connect a 47-kilohm resistor with a 1-megohm pad in series to one side of the GENERATOR OUTPUT BALANCED terminals, as shown in figure 3-1.
- c. Connect an external audio oscillator between the GENERATOR OUTPUT GND terminal and floating end of the 47K-ohm resistor, as shown in figure 3-1.

d. Set front panel controls as follows:

PK EQUIV V/PWR	-----	in
RATIO	-----	1:1
HF ONLY	-----	in
LF ONLY	-----	out
GENERATOR OUTPUT switches	-----	+10, -2
INPUT	-----	1 Volt Range
RATIO	-----	-40 dB (1%)
THD ADJUST	-----	CAL

e. Connect vertical input of oscilloscope to OUTPUT MONITOR. Set controls as follows:

Vertical Sensitivity	-----	20 mV/cm
Sweep	-----	5 ms/cm
Sync	-----	Internal

f. Set external audio oscillator frequency to approximately 7 kHz.

g. With output of external oscillator reduced to zero, adjust OUTPUT VERNIER for 1710A meter reading as close to exact full scale as possible.

h. Change front panel controls as follows:

GENERATOR OFF switch	-----	out
LF ONLY	-----	in
INPUT	-----	.01 volt range

Adjust output of external oscillator for a meter reading as close to exact full scale as possible.

i. Change front panel controls as follows:

LF ONLY	-----	out
OUTPUT ATTEN	-----	0 dB
INPUT	-----	3 volt range
GENERATOR OFF switch	-----	out

Adjust the frequency of the external oscillator for a 10 to 15 ms period of the sine wave appearing on the scope.

Adjust IM SET LEVEL control for an exact full scale reading on the meter.

j. Depress IMD pushbutton. Adjust R63 on the IM Analyzer board for an exact full scale reading.

k. Without changing test set-up, proceed to next adjustment (Auto Set Level).

3-12. AUTO SET LEVEL ADJUSTMENT

a. Turn THD ADJUST control to Auto position. Adjust R6 on the auto set level board for an exact full-scale (1.00%) reading.

b. Switch INPUT switch to 10 volt range. Check that reading is 1.00 + .02%.

3-13. TROUBLESHOOTING

Before attempting to troubleshoot the IMD Option ensure that the fault is with the option and not caused by the test setup or associated equipment. The performance check (Paragraph 3-3) enables this to be determined without having to remove the covers.

If an abnormal condition is observed during the performance check, table 3-2 will suggest remedies. However, before proceeding with detailed troubleshooting, note the troubleshooting hints contained in paragraph 3-3 of the Model 1710A Manual.

3-14. SYMPTOM/CAUSE TABLE

Table 3-2 contains symptoms of IMD option malfunctions and provides diagnostic tests for the location of these faults. Following the repair of a defective component, refer to paragraph 3-15 for instructions regarding any necessary calibration and/or adjustment procedures.

Table 3-2. IMD Symptom/Cause Table

Symptom	Probable Cause	Diagnostic Test
Abnormally high level of residual IM distortion, distortion product is random noise.	7 kHz oscillator amplitude instability, Q6 gate voltage out of adjustment	Measure dc level at gate of Q6 on IM analyzer board. Reading should be between 1.0 and 2.0 Vdc.
Abnormally high level of residual IM distortion, distortion product is multiple of 60-Hz	(1) Nonlinearity in IM generator summing amplifier U3, IM analyzer buffer U1. (2) Nonlinearity in THD buffers U101, U102, U103.	(1) Replace U3, U1. (2) Replace U101, U102, U103.
Amplitude of 60-Hz oscillator is unstable, or oscillator is not synced to line.	Q3 gate voltage is out of adjustment.	Measure dc level of gate of Q3 on IM generator board. Reading should be between 1.0 and 2.0 Vdc. Check freq. adjustment per 3-7a.

3-15. COMPONENT REPLACEMENT - CALIBRATION AND ADJUSTMENT

If U1 or U2 in the generator section are replaced, do the oscillator adjustments, section 3-7. In general, changing IC's in the analyzer section do not require re-adjustment. The exception is U6 in the Absolute Value Detector. Changing U6 would require the zero adjustment at TP4, section 3-10.

3-16. ACCESS TO LOW-DISTORTION OSCILLATOR

In order to reach the low-distortion oscillator assembly, it is necessary to move the IM analyzer board mounted above it. To reach the oscillator, proceed as follows:

- a. Remove top cover from instrument.
- b. Locate metal shield on which IM analyzer board is mounted.
- c. Remove four screws attaching this shield to instrument. Do not remove screws securing IM analyzer board to shield.
- d. Carefully move shield back until pushbuttons on board clear rear of front panel.
- e. Move shield until it is located vertically above center of instrument. Secure IM analyzer shield to center IM support bar using one of the screws previously removed. This holds board in a position that permits access to oscillator. Replace IM analyzer board following reverse procedure.
- f. Remove two screws (one on each side) holding shielded box down. Carefully pull out generator level switches, removing them from shafts, as described in Section III of the Model 1710A Manual.

Loosen set screws on generator vernier control and generator off switch and move couplers away from shielded box. Be sure not to break off switches.

Lift box up on its hinges. (Do not allow it to lean against the case of the Model 1710A --- This will cause ground problems.)

Remove bottom plate of shielded box to expose IM generator board.

Replace components following reverse procedure.

3-17. MODIFICATIONS FOR EUROPE AND JAPAN

3-18. DIN (Europe)

- a. The Low Frequency Oscillator is set at 250 Hz and is not synchronized with the power line. The High Frequency Oscillator is at 8 kHz. The IM measurement then conforms to DIN 45403, Page 4 - "Measurement of non-linear distortion in electro-acoustics; intermodulation method", and DIN 45500, Page 6 - "Hi-Fi techniques, requirements for amplifiers".

A scope sync (250 Hz) is available at a BNC connector on the rear panel.

The passive, High-Pass Filter has been changed to have a cut-off frequency of 3.9 kHz.

The Low-Pass Filter has been changed to have a cut-off frequency of 1.25 kHz.

- b. The following parts have been changed:

Reference Designators	Description	Stock No.	Qty.
<u>IM ANALYZER BOARD</u>			
C1, C2	.02 uf, 1%, 33V, plystr	2025-0004	2
C3, C4	.0068 uf, 2.5%, 63V, plystr	2025-0016	2
C32	.0082 uf, 1%, 33V, plystr	2025-0002	
C37	.082 uf, 1%, 33V, plystr	2025-0005	1
C36	.0033 uf, 2.5%, 63V, plystr	2025-0014	1
C36A	680 pf, 2.5%, 63V, plystr	2025-0019	1
R46, 47, 48, 49	5.23 K, 1%, 1/8W, MF	1015-1523	4
<u>IM GENERATOR BOARD</u>			
C1, C2	.022 uf, 2.5%, 63V, plystr	2025-0029	2
R18, 20	10K, .25%, 1/8W, MF	1005-2100	2
R17	10K, 1%, 1/8W, MF	1015-2100	1
R16	52.3K, 1%, 1/8W, MF	1015-2523	1
R3, 5	28.7K, 1%, 1/8W, MF	1015-2287	2

- c. Also, the following changes or additions have been made:

1. Replace R4 (5K trim-pot) with a jumper.
2. Remove R2 (15K, 5%, 1/4W) from board.
3. Remove sync cable to IM generator Board (pad 7).
4. Add shielded cable between pad 5 on generator board and BNC scope sync connector on rear panel.

3-19. 50/60 Hz OPERATION (JAPAN)

The Low Frequency Oscillator is set to 60 Hz and is free-running. A scope sync is available at a BNC connector on the rear panel. Sections 3-18-C-2,3,4 above are applicable.

SECTION IV - DIAGRAMS

4-1. INTRODUCTION

This section contains the circuit diagrams necessary for the operation and maintenance of Option 004. Included are schematic diagrams and component location diagrams.

4-2. SCHEMATIC DIAGRAMS

The circuitry contained within each assembly is shown in the schematic diagrams. As an aid to isolating malfunctions, the diagrams also provide typical operating voltages and wave-forms.

4-3. COMPONENT LOCATION DIAGRAMS

The component location diagrams show the physical location of parts mounted on each assembly. Each part is identified by a reference designator, similarly identified on the schematic diagrams and in the parts list.

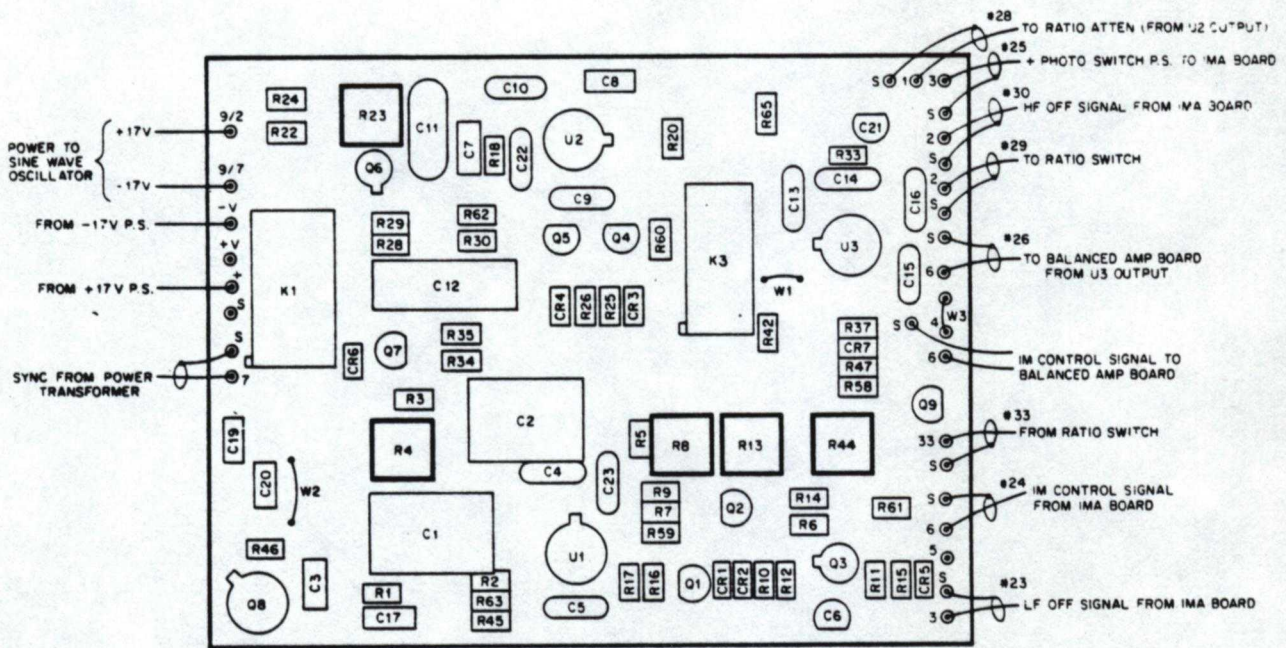

IM GENERATOR BOARD

FIG. 4-1

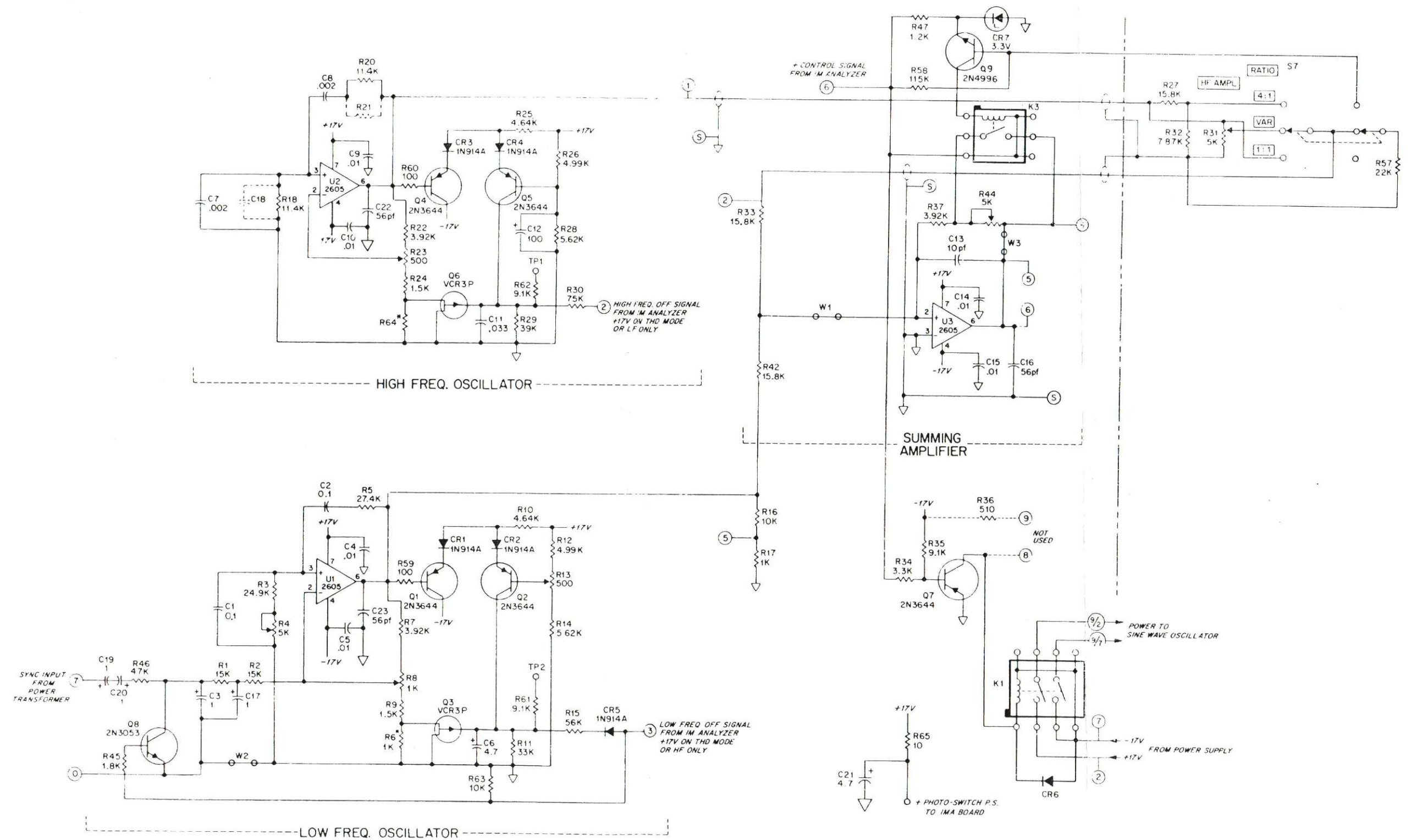

IM GENERATOR
FIG. 4-2

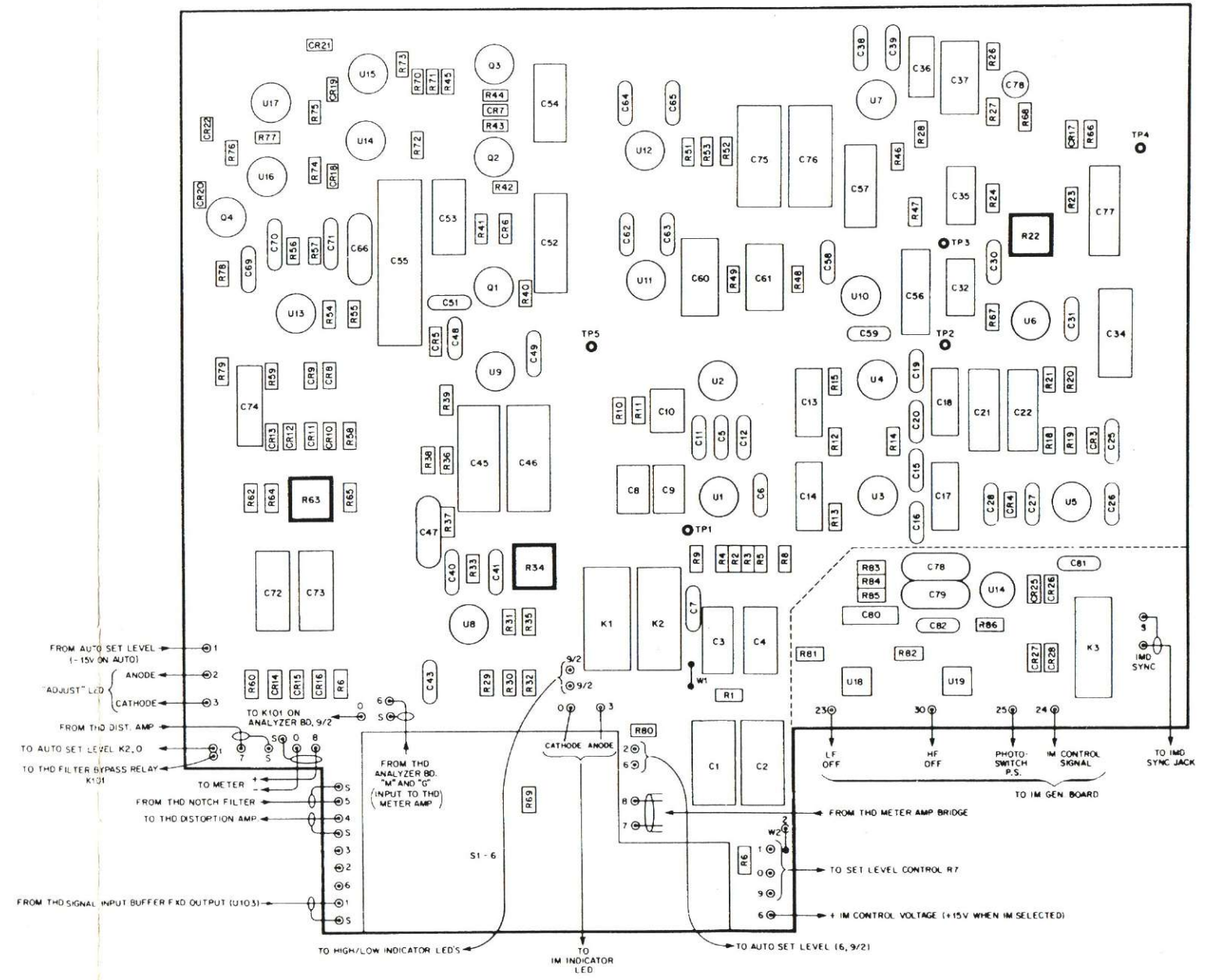

IM ANALYZER

FIG. 4-3

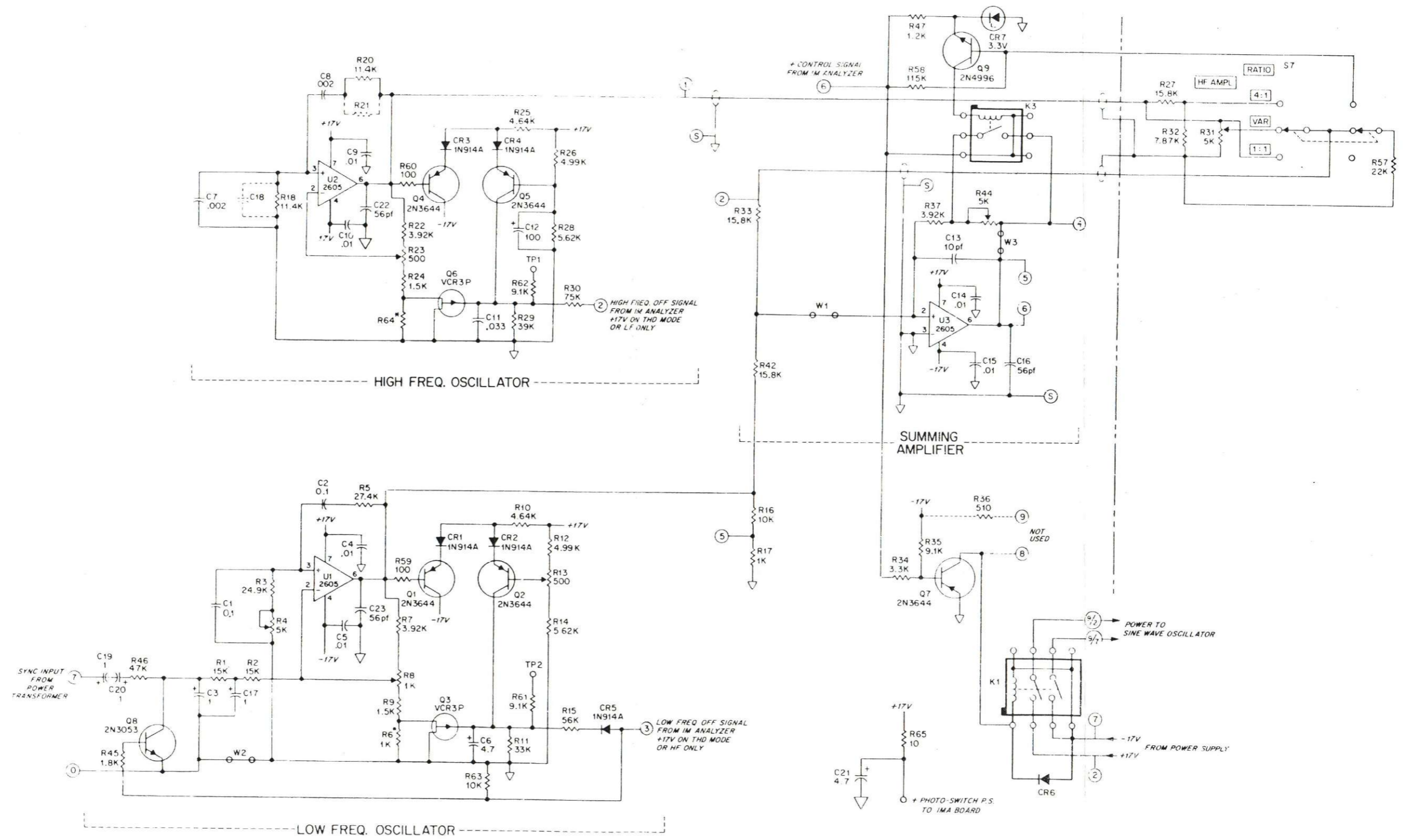

IM GENERATOR

FIG. 4-2

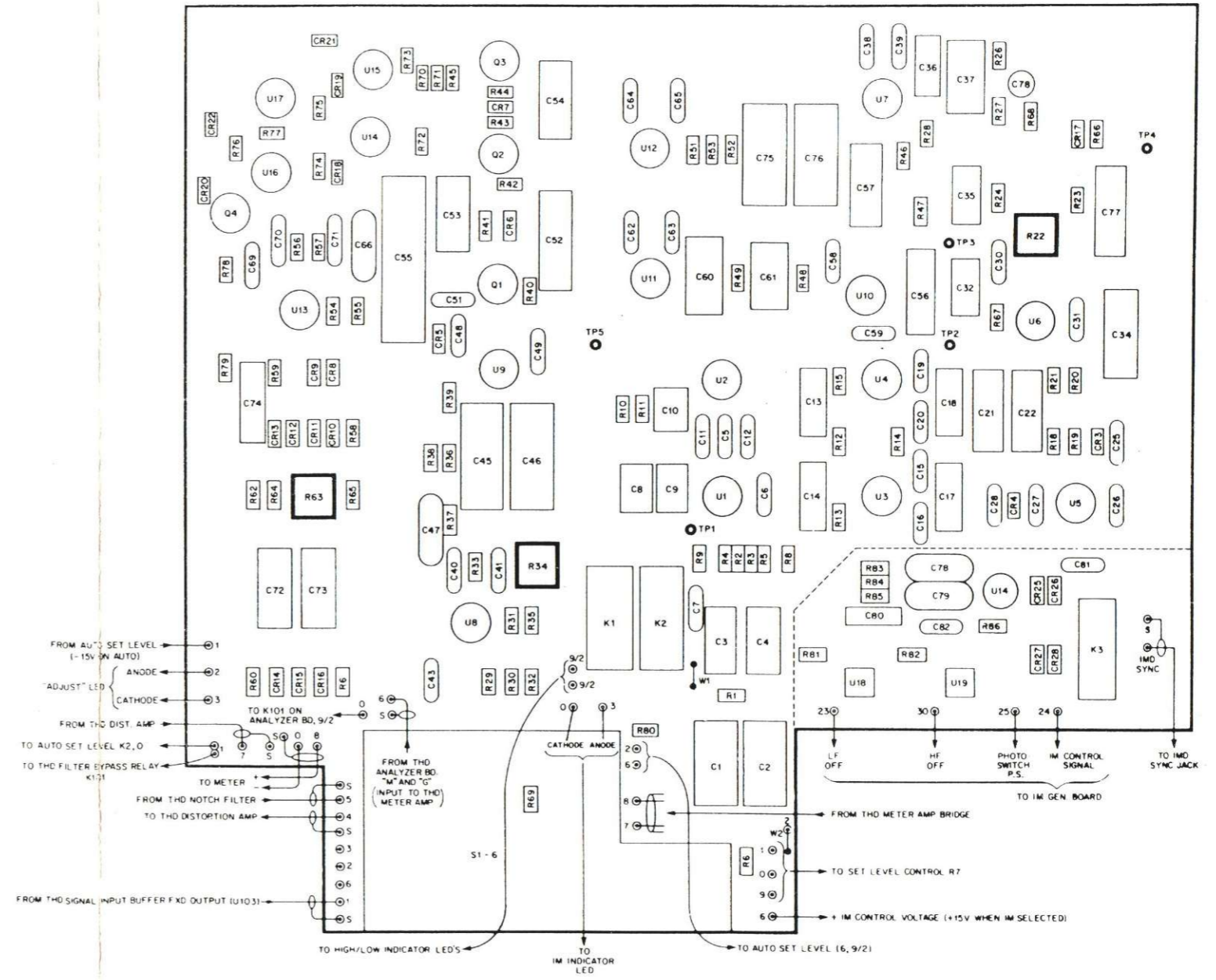

IM ANALYZER

FIG. 4-3

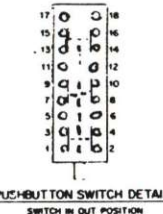
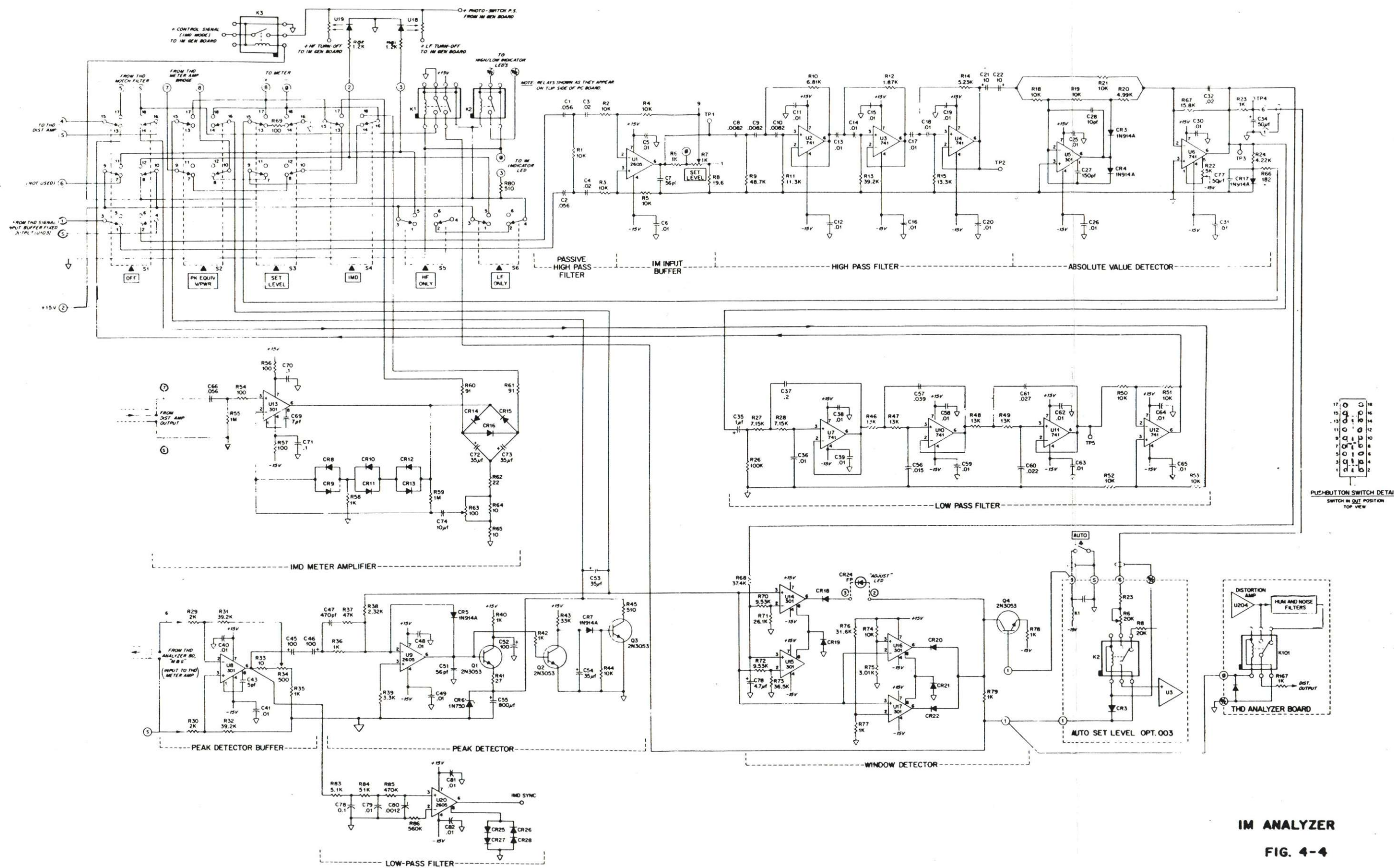

IM ANALYZER
FIG. 4-4

01700-30017
ASSY-PC, IM ANALYZER

PART NO	DESCRIPTION	PART NO	DESCRIPTION
0005-0000	TRANS 2N3053 NPN SI Q1-4	1100-1100	RES-FXD 1K 5% 1/4W R40, 42, 58, 78, 79
0100-0001	IC-OP AMP 741 U2, 3, 4, 6, 7, 10, 11, 12	1100-1120	RES-FXD 1.2K 5% 1/4W R81, 82
0100-0014	IC-OP AMP 2605 GRADE 6 BLUE U1, 9	1100-1330	RES-FXD 3.3K 5% 1/4W R39
0100-0014	IC-OP AMP 2605 GRADE 6 BLUE U20	1100-1510	RES-FXD 5.1K 5% 1/4W R83
0100-0016	OP-AMP 301C U5, 8, 13-17	1100-2100	RES-FXD 10K 5% 1/4W R44
0200-0000	DIODE-GEN 1N914A SI CR3-5, 7-22	1100-2330	RES-FXD 33K 5% 1/4W R43
0200-0000	DIODE-GEN 1N914A SI CR25-28	1100-2470	RES-FXD 47K 5% 1/4W R37
0205-0002	DIODE-ZENER 1N750 4.7V CR6	1100-2510	RES-FXD 51K 5% 1/4W R84
0305-0007	PHOTOCELL-LED GRADE 7 VIOLET U18, 19	1100-3100	RES-FXD 100K 5% 1/4W R26
1015-0010	RES-FXD 10 1% 1/8W MF R33, 64, 65	1100-3470	RES-FXD 470K 5% 1/4W R85
1015-0019	RES-FXD 19.6 1% 1/8W MF R8	1100-4100	RES-FXD 1M 5% 1/4W R55, 59
1015-0182	RES-FXD 182 1% 1/8W MF R66	1410-0001	RES-VAR 100 TRIMPOT CERMET R63
1015-1100	RES-FXD 1K 1% 1/8W MF R6, 23, 35, 36, 77	1410-0002	RES-VAR 500 TRIMPOT CERMET R34
1015-1187	RES-FXD 1.87K 1% 1/8W MF R12	1410-0017	RES-VAR 5K TRIMPOT CERMET R22
1015-1200	RES-FXD 2K 1% 1/8W MF R29, 30	2000-0005	CAP-FXD 5PF 10% 500V MICA C43
1015-1232	RES-FXD 2.32K 1% 1/8W MF R38	2000-0007	CAP-FXD 7PF 5% 500V MICA C69
1015-1301	RES-FXD 3.01K 1% 1/8W R75	2000-0010	CAP-FXD 10PF 5% 500V MICA C28
1015-1422	RES-FXD 4.22K 1% 1/8W MF R24	2000-0056	CAP-FXD 56PF 5% 500V MICA C7, 51
1015-1499	RES-FXD 4.99K 1% 1/8W MF R20	2000-0150	CAP-FXD 150PF 5% 500V MICA C27
1015-1523	RES-FXD 5.23K 1% 1/8W MF R14	2000-0470	CAP-FXD 470PF 5% 500V MICA C47
1015-1681	RES-FXD 6.81K 1% 1/8W MF R10	2020-0000	CAP-FXD 0.01UF 10% 100V MYLAR C79
1015-1715	RES-FXD 7.15K 1% 1/8W MF R27, 28	2020-0002	CAP-FXD 0.056UF 10% 100V MYLAR C66
1015-1953	RES-FXD 9.53K 1% 1/8W R70, 72	2020-0003	CAP-FXD 0.1UF 10% 100V MYLAR C78
1015-2100	RES-FXD 10K 1% 1/8W MF R1-5, 18, 19, 21, 50-53, 74	2025-0002	CAP-FXD 0.0082UF 1% 33V PLYSTR C8-10
1015-2113	RES-FXD 11.3K 1% 1/8W MF R11	2025-0003	CAP-FXD 0.01UF 1% 33V PLYSTR C13, 14, 17, 18, 36
1015-2130	RES-FXD 13.0K 1% 1/8W MF R46-49	2025-0004	CAP-FXD 0.02UF 1% 33V PLYSTR C3, 4, 32
1015-2133	RES-FXD 13.3K 1% 1/8W MF R15	2025-0007	CAP-FXD 0.2UF 1% 100V FILM C37
1015-2158	RES-FXD 15.8K 1% 1/8W MF R67	2025-0010	CAP-FXD .039UF 2.5% 33V PLYSTR C57
1015-2261	RES-FXD 26.1K 1% 1/8W MF R71	2025-0011	CAP-FXD .0012UF 2.5% 63V PLYSTR C80
1015-2316	RES-FXD 31.6K 1% 1/8W MF R76	2025-0015	CAP-FXD .015UF 2.5% 63V PLYSTR C56
1015-2365	RES-FXD 36.5K 1% 1/8W R73	2025-0017	CAP-FXD .056UF 2.5% 33V PLYSTR C1, 2
1015-2374	RES-FXD 37.4K 1% 1/8W MF R68	2025-0029	CAP-FXD .022UF 2.5% 63V PLYSTR C60
1015-2392	RES-FXD 39.2K 1% 1/8W MF R13, 31, 32	2025-0030	CAP-FXD .027UF 2.5% 63V PLYSTR C61
1015-2487	RES-FXD 48.7K 1% 1/8W MF R9		
1100-0022	RES-FXD 22 5% 1/4W R62		
1100-0027	RES-FXD 27 5% 1/4W R41		
1100-0091	RES-FXD 91 5% 1/4W R60, 61		
1100-0100	RES-FXD 100 5% 1/4W R54, 56, 57, 69		
1100-0510	RES-FXD 510 5% 1/4W R45, 80		

PART NO	DESCRIPTION
2040-0000	CAP-FXD 0.01UF 100V CERAMIC 48, 49, C5, 6, 11, 12, 15, 16, 19, 20, 25, 26, 30, 31, 38-41
2040-0000	CAP-FXD 0.01UF 100V CERAMIC C81, 82
2040-0002	CAP-FXD 0.1UF 25V CERAMIC C70, 71
2100-0000	CAP-FXD 4.7UF 10% 35V TANT C78
2100-0001	CAP-FXD 1UF 25V ELECT AL C35
2100-0003	CAP-FXD 10UF 25V ELECT AL C21, 22, 74
2100-0004	CAP-FXD 35UF 25V ELECT AL C53, 54, 72, 73
2100-0005	CAP-FXD 50UF 25V ELECT AL C34, 77
2100-0006	CAP-FXD 100UF 25V ELECT AL C45, 46, 52, 75, 76
2100-0019	CAP-FXD 800UF 6V ELECT C55
3015-0007	SWITCH-PB, 4 STA 6P & 2 STA P-P S1-6
3105-0000	SOCKET-IC 8 PIN ROUND
3105-0000	SOCKET-IC 8 PIN ROUND
3120-0000	CONN-SINGLE CONTACT, .093 PIN
3150-0002	SPACER-PUSHBUTTON SW, DOGBONE
3400-0002	RELAY-1 FORM A K2
3400-0002	RELAY-1 FORM A K3
3400-0003	RELAY-2 FORM A K1

01700-30018
PC-ASSY IM SIGNAL
GENERATOR

PART NO	DESCRIPTION
0000-0001	TRANS 2N3644 PNP SI Q1, 2, 4, 5, 7
0005-0000	TRANS 2N3053 NPN SI Q8
0005-0002	TRANS 2N4996 NPN SI Q9
0020-0001	TRANS-FET VCR3P P-CHAN Q3, 6
0100-0001	IC-OP AMP 741
0100-0007	IC-OP AMP 2605 GRADE 2 RED U3
0100-0014	IC-OP AMP 2605 GRADE 6 BLUE U2
0100-0014	IC-OP AMP 2605 GRADE 6 BLUE U1
0200-0000	DIODE-GEN 1N914A SI CR1-6
0205-0004	DIODE-ZENER 1N746A 3.3V CR7
1005-2114	RES-FXD 11.4K 0.25% 1/8W MF R18, 20
1005-2158	RES-FXD 15.8K 0.25% 1/8W MF R33, 42
1005-3115	RES-FXD 115K 0.25% 1/8W MF R58
1015-1100	RES-FXD 1K 1% 1/8W MF R17
1015-1100	RES-FXD 1K 1% 1/8W MF R6
1015-1150	RES-FXD 1.5K 1% 1/8W MF R9, 24
1015-1392	RES-FXD 3.92K 1% 1/8W MF R7, 22
1015-1392	RES-FXD 3.92K 1% 1/8W MF R37

PART NO	DESCRIPTION	PART NO	DESCRIPTION
1015-1464	RES-FXD 4.64K 1% 1/8W MF R10, 25	2100-0006	CAP-FXD 100UF 25V ELECT AL C12
1015-1464	RES-FXD 4.64K 1% 1/8W MF	2100-0020	CAP-FXD 1UF 50V ELECT TANT C3, 17, 19
1015-1499	RES-FXD 4.99K 1% 1/8W MF	2100-0020	CAP-FXD 1UF 50V ELECT TANT C20
1015-1562	RES-FXD 5.62K 1% 1/8W MF R12, 26, R14, 28	3105-0000	SOCKET-IC 8 PIN ROUND
1015-1576	RES-FXD 5.76K 1% 1/8W MF R41	3120-0000	CONN-SINGLE CONTACT, .093
1015-1576	RES-FXD 5.76K 1% 1/8W MF R41	3120-0000	CONN-SINGLE CONTACT, .093
1015-1576	RES-FXD 5.76K 1% 1/8W MF R41	3400-0001	RELAY-1 FORM C K2
1015-1681	RES-FXD 6.81K 1% 1/8W MF	3400-0001	RELAY-1 FORM C K2
1015-1681	RES-FXD 6.81K 1% 1/8W MF	3400-0002	RELAY-1 FORM A K3
1015-1681	RES-FXD 6.81K 1% 1/8W MF	3400-0003	RELAY-2 FORM A K1
1015-2100	RES-FXD 10K 1% 1/8W MF		
1015-2249	RES-FXD 24.9K 1% 1/8W MF R3		
1015-2274	RES-FXD 27.4K 1% 1/8W MF R5		
1100-0010	RES-FXD 10 5% 1/4W R65		
1100-0100	RES-FXD 100 5% 1/4W R59, 60		
1100-1100	RES-FXD 1K 5% 1/4W		
1100-1120	RES-FXD 1.2K 5% 1/4W R47		
1100-1180	RES-FXD 1.8K 5% 1/4W R45		
1100-1330	RES-FXD 3.3K 5% 1/4W		
1100-1910	RES-FXD 9.1K 5% 1/4W R35		
1100-2100	RES-FXD 10K 5% 1/4W R63		
1100-2150	RES-FXD 15K 5% 1/4W R1, 2		
1100-2180	RES-FXD 18K 5% 1/4W		
1100-2180	RES-FXD 18K 5% 1/4W		
1100-2330	RES-FXD 33K 5% 1/4W R11		
1100-2390	RES-FXD 39K 5% 1/4W R29		
1100-2470	RES-FXD 47K 5% 1/4W R46		
1100-2560	RES-FXD 56K 5% 1/4W R15		
1100-2750	RES-FXD 75K 5% 1/4W R30		
1410-0015	RES-VAR 500 TRIM, .15 SPACING R13, 23		
1410-0016	RES-VAR 1K TRIM, .15 SPACING R8, 43		
1410-0016	RES-VAR 1K TRIM, .15 SPACING		
1410-0017	RES-VAR 5K TRIM, .15 SPACING R4		
1410-0017	RES-VAR 5K TRIM, .15 SPACING R44		
2000-0010	CAP-FXD 10PF 5% 500V MICA C13		
2000-0056	CAP-FXD 56PF 5% 500V MICA C16		
2020-0013	CAP-FXD 0.033UF 10% 100V MYLAR		
2025-0001	CAP-FXD 0.002UF 1% 33V PLYSTR C7, 8		
2025-0006	CAP-FXD 0.1UF 1% 33V PLYSTR C1, 2		
2040-0000	CAP-FXD 0.01UF 100V CERAMIC C4, 5, 9, 10, 14, 15		
2100-0000	CAP-FXD 4.7UF 10% 35V TANT C6		
2100-0000	CAP-FXD 4.7UF 10% 35V TANT C21		

OPTION 005 OUTPUT ATTENUATOR AND METER CALIBRATED FOR 150 AND 600 OHMS

1. DESCRIPTION

2. GENERATOR OUTPUT *power* is unchanged when the SOURCE IMPEDANCE switch is in either the 150Ω position or the 600Ω position. GENERATOR LEVEL controls, and the dB scales of the special meter, are calibrated for both 150 and 600 ohm loads. All other instrument specifications remain unchanged.
3. A Relay Board (P/N: 01710-30013) has been added to the instrument, and is electrically inserted in the Balanced Amplifier circuit between the 1 dB/-STEP switch (S2) and the VERNIER control (R10).

PARTS LIST RELAY BOARD

ASSY: 01710-30013

REF	S-T	P/N
C1		2100-0024
CR1		0200-0000
K1		3400-0001
R1		1100-0330
R2		1100-0100
R3		1005-0665
R4		1005-1133
METER		3320-0005

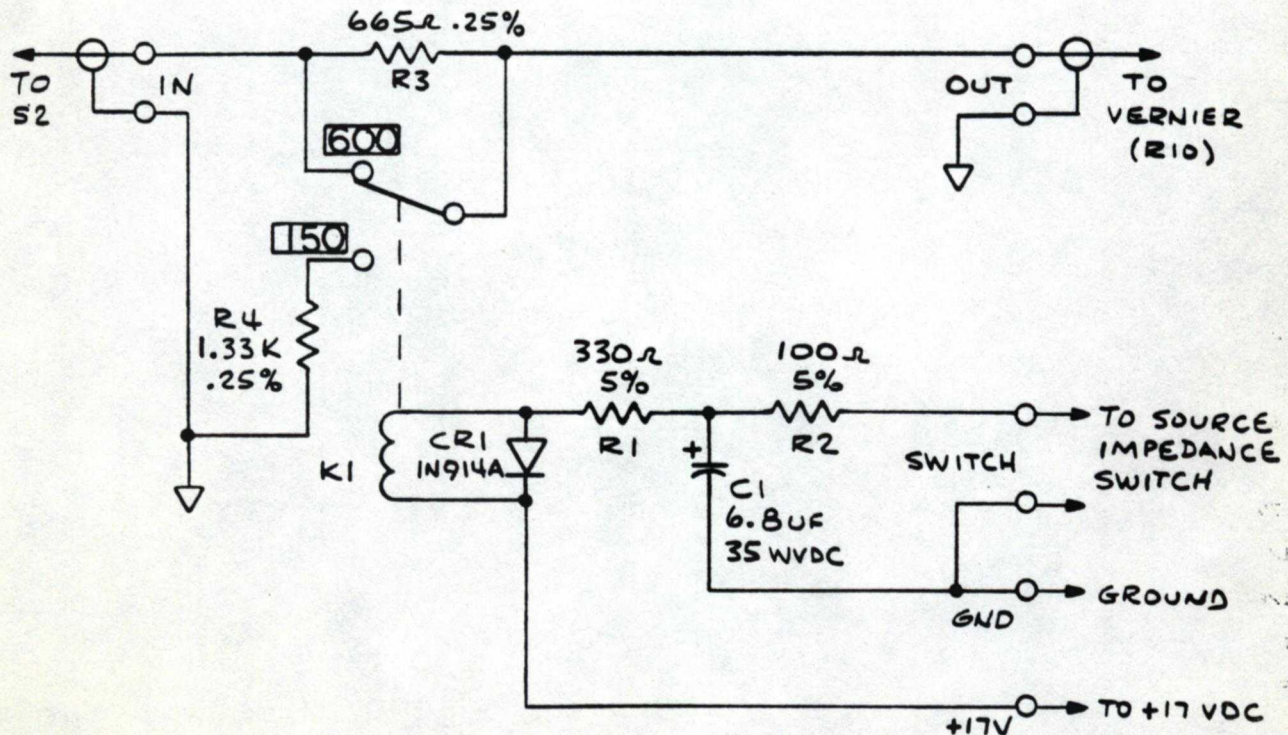

FIGURE O5-1
SCHEMATIC DIAGRAM
OPTION 005 RELAY BOARD

OPTION 007-SELECTABLE METER RESPONSE

07-1. METER RESPONSE SELECTION

07-2. Three buttons located above the panel meter provide three meter responses: average, true rms, and peak reading. Guidelines for the use of these buttons, with specific examples for certain measurements, are presented in the following paragraphs.

07-3. AC meter scales are normally calibrated in such a manner that their indicated readings are equal to the rms value of a pure sine wave. However, meter detection circuits do not necessarily respond to the rms value of the waveform being measured, so errors in the reading can occur if the waveform is not a pure sine wave. The three meter responses of the 1710A are: AVG, RMS, and PEAK.

07-4. **AVG (AVERAGE RESPONDING):** Most meter detection circuits are average responding, therefore many measurement standards specify the use of an average responding meter for almost all measurements. Examples of such standards are the IHF-T-200/IEEE Std 185 (1975): *Standard Methods of Testing FM Broadcast Receivers*, the EIA Std RS-234-C (1971): *EIA Standard Methods of Measurement for Audio Amplifiers Used in Home Equipment*, and the IHF-A-202 (1978): *Standard Methods of Measurement for Audio Amplifiers*. To properly measure devices to these standards, set the 1710A meter response to AVG.

07-5. **RMS (RMS RESPONDING):** When the waveform to be measured is not sinusoidal, an rms responding detection circuit will give a more accurate reading of the true rms value. IHF-A-202 (1978) requires an rms responding meter for measurement of Total Harmonic Distortion plus Noise (THD+N), with an average responding detection circuit for all other measurements. Set the 1710A meter response to RMS for the THD+N measurement, then to AVG for the remaining measurements.

07-6. **PEAK (PEAK RESPONDING):** Distortion products will frequently contain spikes and other high frequency information. This type of distortion is generally considered to be the most objectionable from a sonic standpoint. Since spikes can have a very large peak amplitude in relation to their rms or average amplitude, a peak respond-

ing meter will be much more sensitive to spike amplitude than an rms or average responding meter. Set the 1710A meter response to PEAK to obtain the most sensitive measurement of this type of distortion.

07-7. CIRCUIT THEORY

07-8. The average detecting meter circuitry consists of high-gain, wide-band amplifier U104, a full-wave bridge rectifier circuit, and dc milliammeter M1. Meter input sensitivity is 31.6 mV full scale, with meter gain adjusted by R157.

07-9. Circuitry for the RMS and PEAK detecting meter responses is contained on the Meter Circuits Board (see Figure), with the meter connected directly to the board through the RMS and PEAK switches.

07-10. In the RMS mode, op amp U1 drives U2 which contains an absolute value amplifier, a squarer-divider, and a current mirror. The output of U2 drives M1 through the RMS switch.

07-11. In the PEAK mode, U1 drives negative and positive peak detectors U3 and U5, and their associated circuitry. (The operation of the negative circuitry will be explained, with the positive circuitry being similar.) The input to the peak detector may be considered to be the output of U1. U3 operates as a summing amplifier, with the current summed at the junction of R9/R10. Meter current (1 ma full scale) flows back to the summing point through R10. If the peak negative current through R9 exceeds the current through R10, the output of U3 will go positive and add charge to C14 through Q1. This added charge will then increase the average meter current. As long as U3's output swings positive each cycle, Q3 will conduct, thus holding down the voltage on C15 and preventing Q4 from conducting. If the peak input current does not exceed the feedback current, U3 output remains clamped negative by CR3 at approximately 0.7 V. In this event, the voltage on C54 will rise, and Q4 will conduct to quickly reduce the charge on C14. This allows the meter to respond quickly to a decreasing signal level.

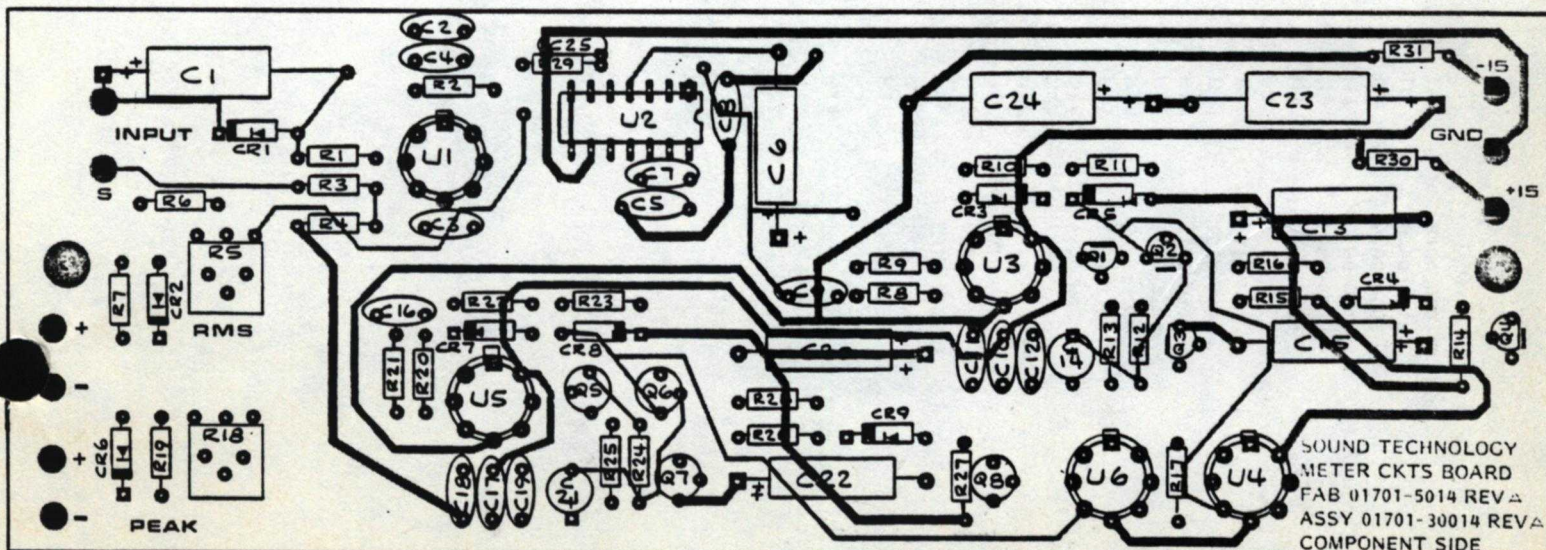

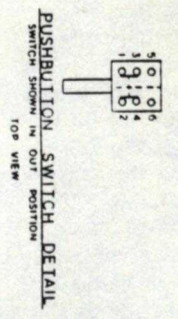
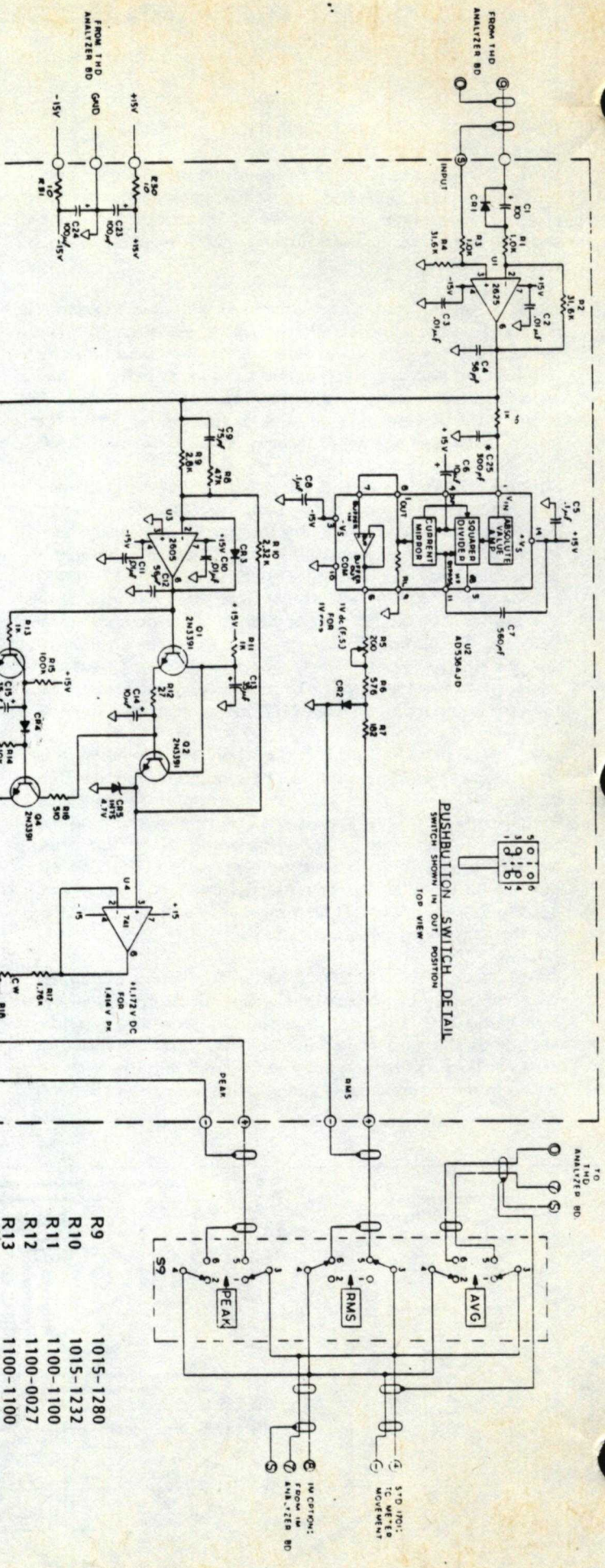

METER RESPONSE -
PCB ASSY: 01701-30014

CKT REF	S-T P/N	QTY	DESCRIPTION
C1	2100-0006	1	RESISTOR
C2-3	2040-0000	2	CAPACITOR
C4	2000-0056	1	CAPACITOR
C5	2040-0002	1	CAPACITOR
C6	2100-0022	1	CAPACITOR
C7	2000-0560	1	CAPACITOR
C8	2040-0002	1	CAPACITOR
C9	2000-0075	1	CAPACITOR
C10-11	2040-0000	2	CAPACITOR
C12	2000-0056	1	CAPACITOR
C13	2100-0004	1	CAPACITOR
C14	2100-0025	1	CAPACITOR
C15	2100-0004	1	CAPACITOR
C16	2100-0075	1	CAPACITOR
C17-18	2040-0000	2	CAPACITOR
C19	2000-0056	1	CAPACITOR
C20	2100-0004	1	CAPACITOR
C21	2100-0025	1	CAPACITOR
C22	2100-0004	1	CAPACITOR
C23-24	2100-0006	2	CAPACITOR
C25	2000-0300	1	CAPACITOR
R1	1015-1100	1	RESISTOR
R2	1015-2316	1	RESISTOR
R3	1015-1100	1	RESISTOR
R4	1015-2316	1	RESISTOR
R5	1410-0014	1	RESISTOR
R6	1015-0576	1	RESISTOR
R7	1015-0182	1	RESISTOR
R8	1100-2470	1	RESISTOR
R9	1015-1280	1	RESISTOR
R10	1015-1232	1	RESISTOR
R11	1100-1100	1	RESISTOR
R12	1100-0027	1	RESISTOR
R13	1100-1100	1	RESISTOR
R14	1100-2100	1	RESISTOR
R15	1100-3100	1	RESISTOR
R16	1100-0510	1	RESISTOR
R17	1005-1176	1	RESISTOR
R18	1410-0015	1	RESISTOR
R19	1015-0182	1	RESISTOR
R20	1100-2470	1	RESISTOR
R21	1015-1280	1	RESISTOR
R22	1015-1232	1	RESISTOR
R23	1100-1100	1	RESISTOR
R24	1100-0027	1	RESISTOR
R25	1100-1100	1	RESISTOR
R26	1100-3100	1	RESISTOR
R27	1100-2100	1	RESISTOR
R28	1100-0510	1	RESISTOR
R29	1015-1100	1	RESISTOR
R30-31	1015-0010	2	RESISTOR
U1	0100-0003	1	IC
U2	0100-0019	1	IC
U3	0100-0014	1	IC
U4	0100-0001	1	IC
U5	0100-0014	1	IC
U6	0100-0001	1	IC