

TYPE CODE

- Throughout this manual, the following abbreviations are used to identify individual type.

CODE	AREA TYPE
CH	China

A Few Words About Safety

Service Information

The service and repair information contained in this manual is intended for use by qualified, professional technicians. Attempting service or repairs without the proper training, tools, and equipment could cause injury to you or others. It could also damage the vehicle or create an unsafe condition.

This manual describes the proper methods and procedures for performing service, maintenance, and repairs. Some procedures require the use of specially designed tools and dedicated equipment. Any person who intends to use a replacement part, service procedure or a tool that is not recommended by Honda, must determine the risks to their personal safety and the safe operation of the vehicle.

If you need to replace a part, use genuine Honda parts with the correct part number or an equivalent part. We strongly recommend that you do not use replacement parts of inferior quality.

For Your Customer's Safety

Proper service and maintenance are essential to the customer's safety and the reliability of the vehicle. Any error or oversight while servicing a vehicle can result in faulty operation, damage to the vehicle, or injury to others.

For Your Safety

Because this manual is intended for the professional service technician, we do not provide warnings about many basic shop safety practices (e.g., Hot parts—wear gloves). If you have not received shop safety training or do not feel confident about your knowledge of safe servicing practice, we recommended that you do not attempt to perform the procedures described in this manual.

Some of the most important general service safety precautions are given below. However, we cannot warn you of every conceivable hazard that can arise in performing service and repair procedures. Only you can decide whether or not you should perform a given task.

Important Safety Precautions

Make sure you have a clear understanding of all basic shop safety practices and that you are wearing appropriate clothing and using safety equipment. When performing any service task, be especially careful of the following:

- Read all of the instructions before you begin, and make sure you have the tools, the replacement or repair parts, and the skills required to perform the tasks safely and completely.
- Protect your eyes by using proper safety glasses, goggles or face shields any time you hammer, drill, grind, pry or work around pressurized air or liquids, and springs or other stored-energy components. If there is any doubt, put on eye protection.
- Use other protective wear when necessary, for example gloves or safety shoes. Handling hot or sharp parts can cause severe burns or cuts. Before you grab something that looks like it can hurt you, stop and put on gloves.
- Protect yourself and others whenever you have the vehicle up in the air. Any time you lift the vehicle, either with a hoist or a jack, make sure that it is always securely supported. Use jack stands.

Make sure the engine is off before you begin any servicing procedures, unless the instruction tells you to do otherwise. This will help eliminate several potential hazards:

- Carbon monoxide poisoning from engine exhaust. Be sure there is adequate ventilation whenever you run the engine.
- Burns from hot parts or coolant. Let the engine and exhaust system cool before working in those areas.
- Injury from moving parts. If the instruction tells you to run the engine, be sure your hands, fingers and clothing are out of the way.

Gasoline vapors and hydrogen gases from batteries are explosive. To reduce the possibility of a fire or explosion, be careful when working around gasoline or batteries.

- Use only a nonflammable solvent, not gasoline, to clean parts.
- Never drain or store gasoline in an open container.
- Keep all cigarettes, sparks and flames away from the battery and all fuel-related parts.

▲ WARNING

Improper service or repairs can create an unsafe condition that can cause your customer or others to be seriously hurt or killed.

Follow the procedures and precautions in this manual and other service materials carefully.

▲ WARNING

Failure to properly follow instructions and precautions can cause you to be seriously hurt or killed.

Follow the procedures and precautions in this manual carefully.

HOW TO USE THIS MANUAL

This service manual describes the service procedures for the CGR125 - 5.

Follow the Maintenance Schedule (Section 3) recommendations to ensure that the vehicle is in peak operating condition and the emission levels are within the standard set.

Performing the first scheduled maintenance is very important. It compensates for the initial wear that occurs during the break-in period.

Sections 1 and 3 apply to the whole motorcycle. Section 2 illustrates procedures for removal/installation of components that may be required to perform service described in the following sections. Section 4 through 18 describe parts of the motorcycle, grouped according to location.

Find the section you want on this page, then turn to the table of contents on the first page of the section.

Most sections start with an assembly or system illustration, service information and troubleshooting for the section. The subsequent pages give detailed procedure.

If you don't know the source of the trouble, go to section 20 Troubleshooting.

Your safety, and the safety of others, is very important. To help you make informed decisions we have provided safety messages and other information throughout this manual. Of course, it is not practical or possible to warn you about all the hazards associated with servicing this vehicle. You must use your own good judgement. You will find important safety information in a variety of forms including:

- Safety Labels – on the vehicle
- Safety Messages – preceded by a safety alert symbol  and one of three signal words, DANGER, WARNING, or CAUTION. These signal words mean:
 - DANGER** You WILL be KILLED or SERIOUSLY HURT if you don't follow instructions.
 - WARNING** You CAN be KILLED or SERIOUSLY HURT if you don't follow instructions.
 - CAUTION** You CAN be HURT if you don't follow instructions.
- Instructions – how to service this vehicle correctly and safely.

As you read this manual, you will find information that is preceded by a **NOTICE** symbol. The purpose of this message is to help prevent damage to your vehicle, other property, or the environment.

ALL INFORMATION, ILLUSTRATIONS, DIRECTIONS AND SPECIFICATIONS INCLUDED IN THIS PUBLICATION ARE BASED ON THE LATEST PRODUCT INFORMATION AVAILABLE AT THE TIME OF APPROVAL FOR PRINTING. Honda Motor Co., Ltd. RESERVES THE RIGHT TO MAKE CHANGES AT ANY TIME WITHOUT NOTICE AND WITHOUT INCURRING ANY OBLIGATION WHATSOEVER. NO PART OF THIS PUBLICATION MAY BE REPRODUCED WITHOUT WRITTEN PERMISSION. THIS MANUAL IS WRITTEN FOR PERSONS WHO HAVE ACQUIRED BASIC KNOWLEDGE OF MAINTENANCE ON Honda MOTORCYCLES, MOTOR SCOOTERS OR ATVS.











Honda Motor Co., Ltd.
SERVICE PUBLICATION OFFICE

CONTENTS

	GENERAL INFORMATION	1
	FRAME/BODY PANELS/EXHAUST SYSTEM	2
	MAINTENANCE	3
ENGINE	LUBRICATION SYSTEM	4
	FUEL SYSTEM	5
	ENGINE REMOVAL/INSTALLATION	6
	CYLINDER HEAD/VALVES	7
	CYLINDER/PISTON/CAMSHAFT	8
	CLUTCH/GEARSHIFT LINKAGE	9
	ALTERNATOR/STARTER CLUTCH	10
	CRANKSHAFT/TRANSMISSION/KICKSTARTER	11
CHASSIS	FRONT WHEEL/BRAKE/SUSPENSION/STEERING	12
	REAR WHEEL/BRAKE/SUSPENSION	13
	HYDRAULIC BRAKE	14
ELECTRICAL	BATTERY/CHARGING SYSTEM	15
	IGNITION SYSTEM	16
	ELECTRIC STARTER	17
	LIGHTS/METERS/SWITCHES	18
	WIRING DIAGRAM	19
	TROUBLESHOOTING	20
	INDEX	21

SYMBOLS

The symbols used throughout this manual show specific service procedures. If supplementary information is required pertaining to these symbols, it would be explained specifically in the text without the use of the symbols.

	Replace the part(s) with new one(s) before assembly.
	Use the recommended engine oil, unless otherwise specified.
	Use molybdenum oil solution (mixture of the engine oil and molybdenum grease in a ratio of 1:1).
	Use multi-purpose grease (lithium based multi-purpose grease NLGI #2 or equivalent).
	Use molybdenum disulfide grease (containing more than 3% molybdenum disulfide, NLGI #2 or equivalent). Example: Molykote® BR-2 plus manufactured by Dow Corning U.S.A. Multi-purpose M-2 manufactured by Mitsubishi Oil, Japan
	Use molybdenum disulfide paste (containing more than 40% molybdenum disulfide, NLGI #2 or equivalent). Example: Molykote® G-n Paste manufactured by Dow Corning U.S.A. Honda Moly 60 (U.S.A. only) Rocol ASP manufactured by Rocol Limited, U.K. Rocol Paste manufactured by Sumico Lubricant, Japan
	Use silicone grease.
	Apply a locking agent. Use a medium strength locking agent unless otherwise specified.
	Apply sealant.
	Use DOT 3 or DOT 4 brake fluid. Use the recommended brake fluid unless otherwise specified.
	Use fork or suspension fluid.

1. GENERAL INFORMATION

SERVICE RULES	1-2	REAR WHEEL/BRAKE/SUSPENSION SPECIFICATIONS.....	1-8
MODEL IDENTIFICATION.....	1-2	HYDRAULIC BRAKE SPECIFICATIONS (TYPE II, IV).....	1-8
GENERAL SPECIFICATIONS.....	1-4	BATTERY/CHARGING SYSTEM SPECIFICATIONS.....	1-9
LUBRICATION SYSTEM SPECIFICATIONS ·	1-5	IGNITION SYSTEM SPECIFICATIONS	1-9
FUEL SYSTEM SPECIFICATIONS.....	1-5	ELECTRIC STARTER SPECIFICATIONS	1-9
CYLINDER HEAD/VALVES SPECIFICATIONS.....	1-5	LIGHTS/METERS/SWITCHES SPECIFICATIONS.....	1-9
CYLINDER/PISTON SPECIFICATIONS	1-6	STANDARD TORQUE VALUES	1-10
CLUTCH/GEARSHIFT LINKAGE SPECIFICATIONS.....	1-6	ENGINE & FRAME TORQUE VALUES	1-10
CRANKSHAFT/TRANSMISSION/ KICKSTARTER SPECIFICATIONS	1-7	LUBRICATION & SEAL POINTS	1-14
FRONT WHEEL/BRAKE/SUSPENSION/ STEERING SPECIFICATIONS.....	1-8	CABLE & HARNESS ROUTING	1-16
		EMISSION CONTROL SYSTEMS	1-25

GENERAL INFORMATION

SERVICE RULES

1. Use genuine Honda or Honda-recommended parts and lubricants or their equivalents. Parts that do not meet Honda's design specifications may cause damage to the motorcycle.
2. Use the special tools designed for this product to avoid damage and incorrect assembly.
3. Use only metric tools when servicing the motorcycle. Metric bolts, nuts and screws are not interchangeable with English fasteners.
4. Install new gaskets, O-rings, cotter pins, and lock plates when reassembling.
5. When tightening bolts or nuts, begin with the larger diameter or inner bolt first. Then tighten to the specified torque diagonally in incremental steps unless a particular sequence is specified.
6. Clean parts in cleaning solvent upon disassembly. Lubricate any sliding surfaces before reassembly.
7. After reassembly, check all parts for proper installation and operation.
8. Route all electrical wires as shown in the Cable and Harness Routing (page 1-16).

MODEL IDENTIFICATION

This manual covers 4 type of CGR125 models.

- Type I: Front drum brake
- Type II: Front disc brake
- Type III: Front drum brake/stripe color
- Type IV: Front disc brake/stripe color

Type II shown

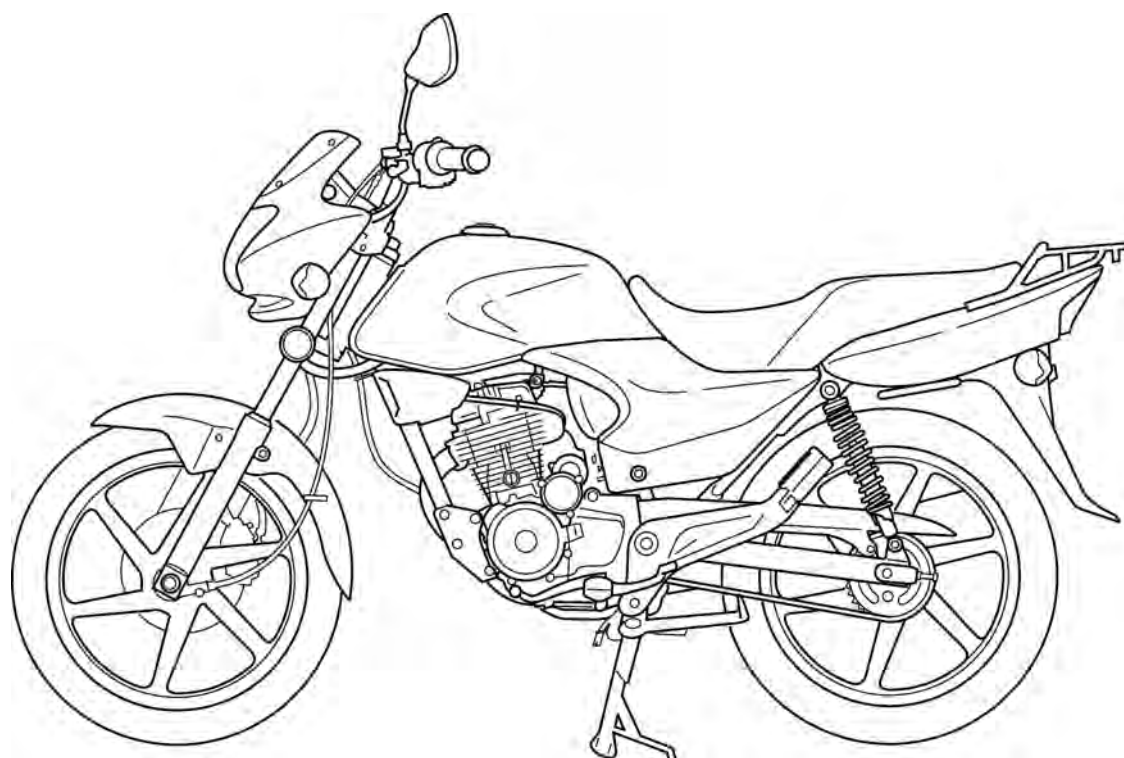

GENERAL INFORMATION

The frame serial number is stamped on the right side of the steering head.

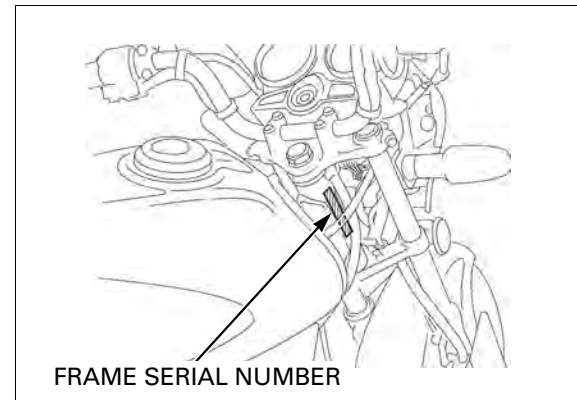

The engine serial number is stamped on the left side of the lower crankcase.

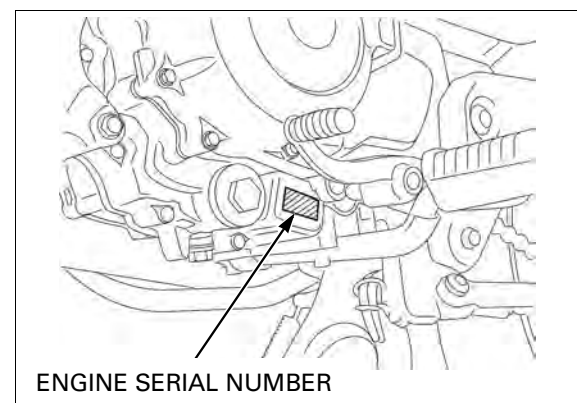

The carburetor identification number is stamped on the right side of the carburetor body.

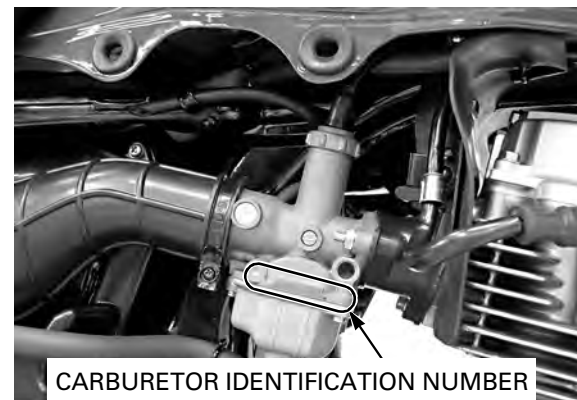

The color label is attached as shown. When ordering color-coded parts, always specify the designated color code.

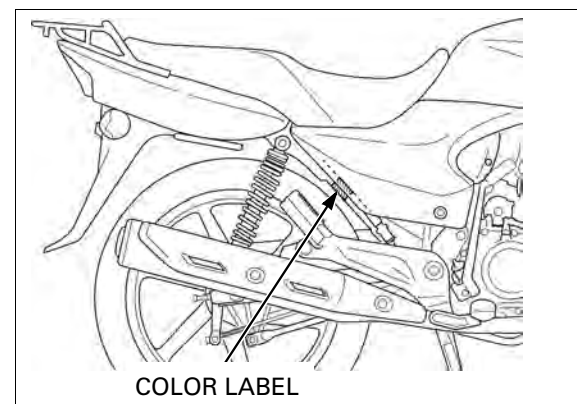

GENERAL INFORMATION

GENERAL SPECIFICATIONS

	ITEM	SPECIFICATION	
DIMENSIONS	Overall length	2,052 mm (80.8 in)	
	Overall width	783 mm (30.8 in)	
	Overall height	1,050 mm (41.3 in)	
		Type I, III Type II, IV	1,053 mm (41.5 in)
	Wheelbase		1,281 mm (50.4 in)
	Seat height		755 mm (29.7 in)
	Footpeg height		293 mm (11.5 in)
	Ground clearance		140 mm (5.5 in)
	Dry weight	Type I, III Type II, IV	119.0 kg (262.3 lbs)
	Curb weight	Type I, III Type II, IV	120.5 kg (265.7 lbs)
	Maximum weight capacity		UNDECIDED UNDECIDED 153 kg (337 lbs)
FRAME	Frame type	Backbone	
	Front suspension	Telescopic fork	
	Front axle travel	116 mm (4.6 in)	
	Rear suspension	Swingarm	
	Rear axle travel	80 mm (3.1 in)	
	Front tire size	80/100 - 18 M/C 47P	
	Rear tire size	90/90 - 18 M/C 51P	
	Front brake	Type II, IV Type I, III	Hydraulic single disc Internal expanding shoe
	Rear brake		Internal expanding shoe
	Caster angle		28°00'
	Trail length		99.4 mm (3.91 in)
	Fuel tank capacity		14.0 liter (3.70 US gal, 3.08 Imp gal)
	Fuel tank reserve capacity		2.0 liter (0.53 US gal, 0.44 Imp gal)
ENGINE	Bore and stroke	56.5 x 49.5 mm (2.22 x 1.95 in)	
	Displacement	124.1 cm ³ (7.57 cu-in)	
	Compression ratio	9.0: 1	
	Valve train	Over head valve	
	Intake valve	opens at 1 mm (0.04 in) lift closes at 1 mm (0.04 in) lift	9.5° BTDC 20.5° ABDC
	Exhaust valve	opens at 1 mm (0.04 in) lift closes at 1 mm (0.04 in) lift	39.5° BBDC -9.5° ATDC
	Lubrication system		Forced pressure and wet sump
	Oil pump type		Trochoid
	Cooling system		Air cooled
	Air filtration		Paper filter
	Engine dry weight		30.5 kg (67.2 lbs)
CARBURETOR	Carburetor type	Piston valve	
	Throttle bore	20 mm (0.8 in)	
DRIVE TRAIN	Clutch system	Multi-plate, wet	
	Clutch operation system	Mechanical type	
	Transmission	5 speeds	
	Primary reduction	4.055 (73/18)	
	Final reduction	2.666 (40/15)	
	Gear ratio	1st 2nd 3rd 4th 5th	3.083 (37/12) 1.882 (32/17) 1.400 (28/20) 1.173 (27/23) 1.000 (25/25)
	Gearshift pattern		Left foot operated rotary system, - N - 1 - 2 - 3 - 4 - 5 - N
	ELECTRICAL	Ignition system	AC-CDI
Charging system		Single phase alternator	
Regulator/rectifier		SCR shorted/single phase, full-wave rectification	
Lighting system		Battery	

GENERAL INFORMATION

LUBRICATION SYSTEM SPECIFICATIONS

ITEM		STANDARD	SERVICE LIMIT
Engine oil capacity	After draining	0.8 liter (0.8 US qt, 0.7 Imp qt)	–
	After disassembly	1.1 liter (1.2 US qt, 1.0 Imp qt)	–
Recommended engine oil		Honda 4-stroke oil or equivalent motor oil API service classification: SF or SG Viscosity: SAE 10W-30	–
Oil pump rotor	Tip clearance	0.15 (0.006)	0.20 (0.008)
	Body clearance	0.15 – 0.21 (0.006 – 0.008)	0.40 (0.016)
	Side clearance	0.09 – 0.16 (0.004 – 0.006)	0.25 (0.010)

Unit: mm (in)

FUEL SYSTEM SPECIFICATIONS

ITEM	SPECIFICATIONS
Carburetor identification number	PDCBE
Main jet	#95
Slow jet	#38
Pilot screw initial/final opening	See page 5-21
Float level	14.0 mm (0.55 in)
Idle speed	1,400 ± 100 min ⁻¹ (rpm)
Throttle grip free play	2.0 – 6.0 mm (0.08 – 0.24 in)
PAIR control valve specified vacuum	60 kPa (450 mm Hg)

CYLINDER HEAD/VALVES SPECIFICATIONS

ITEM		STANDARD	SERVICE LIMIT
Cylinder compression		1,226 kPa (12.5 kgf/cm ² , 178 psi) at 450 min ⁻¹ (rpm)	–
Valve clearance		0.08 ± 0.02 (0.003 ± 0.001)	–
Valve, valve guide	Valve stem O.D.	IN	5.450 – 5.465 (0.2146 – 0.2152)
		EX	5.430 – 5.445 (0.2138 – 0.2144)
	Valve guide I.D.	IN/EX	5.475 – 5.485 (0.2156 – 0.2159)
	Stem-to-guide clearance	IN	0.010 – 0.035 (0.0004 – 0.0014)
		EX	0.030 – 0.055 (0.0012 – 0.0022)
Valve seat width	IN/EX	1.2 – 1.5 (0.05 – 0.06)	
Valve spring free length	Inner	IN/EX	33.5 (1.32)
	Outer	IN/EX	40.9 (1.61)
Push rod length		141.15 – 141.45 (5.557 – 5.569)	141.0 (5.55)
Rocker arm	Arm I.D.	IN/EX	12.000 – 12.018 (0.4724 – 0.4731)
	Shaft O.D.	IN/EX	11.977 – 11.995 (0.4715 – 0.4722)
	Arm holder I.D.	IN/EX	12.000 – 12.027 (0.4724 – 0.4735)
	Arm-to-shaft clearance	IN/EX	0.005 – 0.041 (0.0002 – 0.0016)
Cylinder head warpage		–	0.05 (0.002)

Unit: mm (in)

GENERAL INFORMATION

CYLINDER/PISTON SPECIFICATIONS

Unit: mm (in)

ITEM		STANDARD	SERVICE LIMIT	
Camshaft	Cam lobe height	32.768 – 32.928 (1.2901 – 1.2964)	32.63 (1.285)	
	Camshaft I.D.	14.060 – 14.078 (0.5535 – 0.5543)	14.123 (0.5560)	
	Cam gear shaft O.D.	14.030 – 14.040 (0.5524 – 0.5528)	14.017 (0.5518)	
	Camshaft-to-gear shaft clearance	0.020 – 0.048 (0.0008 – 0.0019)	0.106 (0.0042)	
	Cam follower I.D.	12.000 – 12.018 (0.4724 – 0.4731)	12.03 (0.474)	
	Cam follower shaft O.D.	11.984 – 11.994 (0.4718 – 0.4722)	11.96 (0.471)	
	Cam follower-to-follower shaft clearance	0.006 – 0.034 (0.0002 – 0.0013)	0.07 (0.003)	
Cylinder	I.D.	56.500 – 56.512 (2.2244 – 2.2249)	56.60 (2.228)	
	Out-of-round	–	0.10 (0.004)	
	Taper	–	0.10 (0.004)	
	Warpage	–	0.05 (0.002)	
Piston, piston pin, piston ring	Piston O.D. at 8 (0.3) from bottom	56.470 – 56.490 (2.2232 – 2.2240)	56.40 (2.220)	
	Piston pin hole I.D.	15.002 – 15.008 (0.5906 – 0.5909)	15.04 (0.592)	
	Piston pin O.D.	14.994 – 14.998 (0.5903 – 0.5905)	14.96 (0.589)	
	Piston-to-piston pin clearance	0.004 – 0.014 (0.0002 – 0.0006)	0.02 (0.001)	
	Piston ring end gap	Top	0.10 – 0.25 (0.004 – 0.010)	0.5 (0.02)
		Second	0.25 – 0.40 (0.010 – 0.016)	0.5 (0.02)
		Oil (side rail)	0.20 – 0.70 (0.008 – 0.028)	–
	Piston ring-to-ring groove clearance	Top	0.015 – 0.045 (0.0006 – 0.0018)	0.09 (0.004)
Second		0.015 – 0.045 (0.0006 – 0.0018)	0.09 (0.004)	
Cylinder-to-piston clearance		0.010 – 0.042 (0.0004 – 0.0017)	0.10 (0.004)	
Connecting rod small end I.D.		15.010 – 15.022 (0.5909 – 0.5914)	15.06 (0.593)	
Connecting rod-to-piston pin clearance		0.012 – 0.028 (0.0005 – 0.0011)	0.10 (0.004)	

CLUTCH/GEARSHIFT LINKAGE SPECIFICATIONS

Unit: mm (in)

ITEM		STANDARD	SERVICE LIMIT
Clutch lever free play		10 – 20 (0.4 – 0.8)	–
Clutch	Spring free length	35.50 (1.398)	34.20 (1.346)
	Disc thickness	2.90 – 3.00 (0.114 – 0.181)	2.6 (0.10)
	Plate warpage	–	0.20 (0.008)

GENERAL INFORMATION

CRANKSHAFT/TRANSMISSION/KICKSTARTER SPECIFICATIONS

Unit: mm (in)

ITEM		STANDARD	SERVICE LIMIT	
Crankshaft	Connecting rod side clearance	0.10 – 0.30 (0.004 – 0.012)	0.5 (0.02)	
	Connecting rod radial clearance	0.008 – 0.018 (0.0003 – 0.0007)	0.05 (0.002)	
	Runout	–	0.02 (0.001)	
Transmission	Gear I.D.	M3, M5	20.020 – 20.041 (0.7882 – 0.7890)	
		C1	19.520 – 19.541 (0.7685 – 0.7693)	
		C2	22.000 – 22.021 (0.8661 – 0.8670)	
		C4	20.020 – 20.041 (0.7882 – 0.7890)	
	Bushing O.D.	C1	19.479 – 19.500 (0.7669 – 0.7677)	19.43 (0.765)
	Bushing I.D.	C1	16.516 – 16.534 (0.6502 – 0.6509)	16.60 (0.654)
	Gear-to-bushing clearance	C1	0.020 – 0.062 (0.0008 – 0.0024)	0.10 (0.004)
	Mainshaft O.D.	M3	19.959 – 19.980 (0.7858 – 0.7866)	19.91 (0.784)
	Countershaft O.D.	C1	16.466 – 16.484 (0.6483 – 0.6490)	16.41 (0.646)
		C2	21.959 – 21.980 (0.8645 – 0.8654)	21.91 (0.863)
		C4	19.959 – 19.980 (0.7858 – 0.7866)	19.91 (0.784)
	Gear-to-shaft clearance	M3	0.040 – 0.082 (0.0016 – 0.0032)	0.10 (0.004)
		C2	0.020 – 0.062 (0.0008 – 0.0024)	0.10 (0.004)
		C4	0.040 – 0.082 (0.0016 – 0.0032)	0.10 (0.004)
Bushing-to-shaft clearance	C1	0.032 – 0.068 (0.0013 – 0.0027)	0.10 (0.004)	
Shift fork	I.D.	12.000 – 12.018 (0.4724 – 0.4731)	12.05 (0.474)	
	Claw thickness	4.93 – 5.00 (0.194 – 0.197)	4.50 (0.177)	
	Shaft O.D.	11.976 – 11.994 (0.4715 – 0.4722)	11.96 (0.471)	
Kickstarter	Pinion gear I.D.	20.000 – 20.021 (0.7874 – 0.7882)	20.05 (0.789)	
	Spindle O.D.	19.966 – 19.984 (0.7861 – 0.7868)	19.90 (0.783)	

GENERAL INFORMATION

FRONT WHEEL/BRAKE/SUSPENSION/STEERING SPECIFICATIONS

Unit: mm (in)

ITEM		STANDARD	SERVICE LIMIT
Minimum tire tread depth		-	To wear indicator
Cold tire pressure	Driver only	200 kPa (2.00 kgf/cm ² , 29 psi)	-
	Driver and passenger	200 kPa (2.00 kgf/cm ² , 29 psi)	-
Axle runout		-	0.2 (0.01)
Wheel rim runout	Radial	-	1.0 (0.04)
	Axial	-	1.0 (0.04)
Drum brake (Type I, III)	Lever free play	10 – 20 (0.4 – 0.8)	-
	Drum I.D.	130.0 – 130.3 (5.12 – 5.13)	131.0 (5.16)
Fork	Spring free length	485.5 (19.11)	457.2 (18.0)
	Pipe runout	-	0.20 (0.008)
	Recommended fluid	Fork fluid	-
	Fluid level	159 (6.26)	-
	Fluid capacity	65.0 cm ³ (2.20 US oz, 2.29 Imp oz)	-
Steering head bearing pre-load		1.6 – 2.4 kgf (3.53 – 5.29 lbf)	-

REAR WHEEL/BRAKE/SUSPENSION SPECIFICATIONS

Unit: mm (in)

ITEM		STANDARD	SERVICE LIMIT
Minimum tire tread depth		-	To wear indicator
Cold tire pressure	Driver only	225 kPa (2.25 kgf/cm ² , 33 psi)	-
	Driver and passenger	225 kPa (2.25 kgf/cm ² , 33 psi)	-
Axle runout		-	0.2 (0.01)
Wheel rim runout	Radial	-	1.0 (0.04)
	Axial	-	1.0 (0.04)
Drive chain	Size/link	428/108	-
	Slack	10 – 20 (0.4 – 0.8)	-
Brake	Pedal free play	20 – 30 (0.8 – 1.2)	-
	Drum I.D.	130.0 – 130.3 (5.12 – 5.13)	131.0 (5.16)

HYDRAULIC BRAKE SPECIFICATIONS (TYPE II, IV)

Unit: mm (in)

ITEM	STANDARD	SERVICE LIMIT
Recommended brake fluid	DOT 3 or DOT 4	-
Brake disc thickness	3.8 – 4.2 (0.15 – 0.17)	3.5 (0.14)
Brake disc runout	-	0.25 (0.010)
Master cylinder I.D.	12.700 – 12.743 (0.5000 – 0.5017)	12.755 (0.5022)
Master piston O.D.	12.657 – 12.684 (0.4983 – 0.4994)	12.645 (0.4978)
Caliper cylinder I.D.	25.400 – 25.450 (1.0000 – 1.0020)	25.460 (1.0024)
Caliper piston O.D.	25.318 – 25.368 (0.9968 – 0.9987)	25.31 (0.996)

BATTERY/CHARGING SYSTEM SPECIFICATIONS

ITEM		SPECIFICATION	
Battery	Capacity	12 V - 7 Ah	
	Current leakage	0.1 mA max.	
	Specific gravity	Fully charged	1.270 - 1.290 (20°C/68°F)
		Needs charging	Below 1.230 (20°C/68°F)
	Voltage	Fully charged	Above 12.8 V
		Needs charging	Below 12.3 V
Charging current	Normal	0.8 A/5 - 10 h	
	Quick	8 A/1 h	
Alternator	Capacity	0.130 kW/5,000 min ⁻¹ (rpm)	
	Charging coil resistance	0.3 - 1.2 Ω (20°C/68°F)	

IGNITION SYSTEM SPECIFICATIONS

ITEM		SPECIFICATIONS
Spark plug	Standard	DPR8EA-9 (NGK)
	For extended high speed riding	DPR9EA-9 (NGK)
Spark plug gap		0.80 - 0.90 mm (0.031 - 0.035 in)
Ignition coil primary peak voltage		100 V minimum
Exciter coil peak voltage		100 V minimum
Ignition pulse generator peak voltage		0.7 V minimum
Ignition timing ("F" mark)		15° BTDC at idle

ELECTRIC STARTER SPECIFICATIONS

Unit: mm (in)

ITEM	STANDARD	SERVICE LIMIT
Starter motor brush length	12.5 (0.49)	6.5 (0.26)

LIGHTS/METERS/SWITCHES SPECIFICATIONS

ITEM		SPECIFICATION
Bulbs	Headlight (Hi/low beam)	12 V - 35/35 W
	Brake/tail light	12 V - 21/5 W
	Turn signal light	12 V - 10 W x 4
	Position light	12 V - 4 W
	Instrument light	12 V - 1.7 W x 4
	Turn signal indicator	12 V - 3.4 W x 2
	High-beam indicator	12 V - 3.4 W
	Neutral indicator	12 V - 3.4 W
Fuse		15 A
Fuel level sensor resistance (20°C/68°F)	Full	4 - 10 Ω
	Empty	97.5 - 107.5 Ω

GENERAL INFORMATION

STANDARD TORQUE VALUES

FASTENER TYPE	TORQUE N·m (kgf·m, lbf·ft)	FASTENER TYPE	TORQUE N·m (kgf·m, lbf·ft)
5 mm bolt and nut	5 (0.5, 3.7)	5 mm screw	4 (0.4, 3.0)
6 mm bolt and nut (Include SH flange bolt)	10 (1.0, 7)	6 mm screw	9 (0.9, 6.6)
8 mm bolt and nut	22 (2.2, 16)	6 mm flange bolt and nut (Include NSHF)	12 (1.2, 9)
10 mm bolt and nut	34 (3.5, 25)	8 mm flange bolt and nut	26 (2.7, 19)
12 mm bolt and nut	54 (5.5, 40)	10 mm flange bolt and nut	39 (4.0, 29)

ENGINE & FRAME TORQUE VALUES

- Torque specifications listed below are for specified fasteners.
- Others should be tightened to standard torque values listed above.

NOTE:

1. Apply engine oil to the threads and seating surface.
2. Apply locking agent to the threads.
3. UBS nut.
4. U-nut.
5. ALOC bolt/screw; replace with a new one.

ENGINE

MAINTENANCE

ITEM	Q'TY	THREAD DIA. (mm)	TORQUE N·m (kgf·m, lbf·ft)	REMARKS
Air cleaner housing cover screw	4	5	1.8 (0.2, 1.3)	
Spark plug	1	12	18 (1.8, 13)	
Oil drain bolt	1	12	24 (2.4, 18)	
Oil strainer screen cap	1	36	15 (1.5, 11)	NOTE 1
Valve adjusting lock nut	2	6	14 (1.4, 10)	NOTE 1
Timing hole cap	1	14	6 (0.6, 4.4)	
Crankshaft hole cap	1	30	8 (0.8, 5.9)	

LUBRICATION SYSTEM

ITEM	Q'TY	THREAD DIA. (mm)	TORQUE N·m (kgf·m, lbf·ft)	REMARKS
Oil filter rotor cover screw	3	5	5 (0.5, 3.7)	
Oil pump mounting screw	2	6	10 (1.0, 7)	
Oil pump rotor cover screw	2	4	3 (0.3, 2.2)	
Oil pump gear cover bolt	2	5	4 (0.4, 3.0)	

FUEL SYSTEM

ITEM	Q'TY	THREAD DIA. (mm)	TORQUE N·m (kgf·m, lbf·ft)	REMARKS
Choke lever screw	1	4	2.1 (0.2, 1.5)	
Carburetor drain screw	1	6	1.5 (0.2, 1.1)	
Slow jet	1	6	1.8 (0.2, 1.3)	
Needle jet holder	1	7	2.5 (0.3, 1.8)	
Main jet	1	5	2.1 (0.2, 1.5)	
Float chamber screw	3	4	2.1 (0.2, 1.5)	
Air cut-off valve cover screw	2	4	2.1 (0.2, 1.5)	
PAIR control valve mounting nut	2	6	9 (0.9, 6.6)	
Tool box lid screw	2	5	1.8 (0.2, 1.3)	

GENERAL INFORMATION

CYLINDER HEAD/VALVE

ITEM	Q'TY	THREAD DIA. (mm)	TORQUE N·m (kgf·m, lbf·ft)	REMARKS
Cylinder head nut	4	8	32 (3.3, 24)	NOTE 1
Cylinder head bolt	1	8	20 (2.0, 15)	
Cylinder bolt	2	6	10 (1.0, 7)	
Rocker arm shaft bolt	3	6	12 (1.2, 9)	

CLUTCH/GEARSHIFT LINKAGE

ITEM	Q'TY	THREAD DIA. (mm)	TORQUE N·m (kgf·m, lbf·ft)	REMARKS
Clutch lifter plate bolt	4	6	12 (1.2, 9)	
Shift drum stopper arm bolt	1	6	12 (1.2, 9)	
Oil filter rotor lock nut	1	16	54 (5.5, 40)	NOTE 1
Oil filter rotor cover screw	3	5	5 (0.5, 3.7)	
Kickstarter pedal pinch bolt	1	8	27 (2.8, 20)	

ALTERNATOR/STARTER CLUTCH

ITEM	Q'TY	THREAD DIA. (mm)	TORQUE N·m (kgf·m, lbf·ft)	REMARKS
Starter clutch socket bolt	3	6	16 (1.6, 12)	NOTE 2
Flywheel bolt	1	10	74 (7.5, 55)	NOTE 1
Ignition pulse generator mounting bolt	2	5	5 (0.5, 3.7)	NOTE 2

CRANKSHAFT/TRANSMISSION/KICK STARTER

ITEM	Q'TY	THREAD DIA. (mm)	TORQUE N·m (kgf·m, lbf·ft)	REMARKS
Push plug holder bolt	1	6	13 (1.3, 10)	

GENERAL INFORMATION

FRAME

FRAME/BODY PANELS/EXHAUST SYSTEM

ITEM	Q'TY	THREAD DIA. (mm)	TORQUE N-m (kgf-m, lbf-ft)	REMARKS
Exhaust pipe joint nut	2	7	20 (2.0, 15)	
Footpeg bar mounting bolt	4	8	27 (2.8, 20)	

ENGINE REMOVAL/INSTALLATION

ITEM	Q'TY	THREAD DIA. (mm)	TORQUE N-m (kgf-m, lbf-ft)	REMARKS
Gearshift pedal pinch bolt	1	6	12 (1.2, 9)	
Upper engine hanger plate mounting nut	3	8	27 (2.8, 20)	
Front engine hanger bracket mounting nut	4	8	27 (2.8, 20)	
Rear upper/lower engine mounting nut	2	10	54 (5.5, 40)	

FRONT WHEEL/BRAKE/SUSPENSION/STEERING

ITEM	Q'TY	THREAD DIA. (mm)	TORQUE N-m (kgf-m, lbf-ft)	REMARKS
Handlebar holder bolt	4	6	12 (1.2, 9)	
Front brake disc bolt (Type II, IV)	4	8	42 (4.3, 31)	NOTE 5
Front axle nut	1	12	52 (5.3, 38)	
Front brake arm nut (Type I, III)	1	6	10 (1.0, 7)	NOTE 4
Fork cap	2	27	22 (2.2, 16)	
Top bridge pinch bolt	2	8	23 (2.3, 17)	
Bottom bridge pinch bolt	2	8	34 (3.5, 25)	
Steering bearing adjustment nut	1	22	See page 12-35	
Steering stem nut	1	22	74 (7.5, 55)	

REAR WHEEL/BRAKE/SUSPENSION

ITEM	Q'TY	THREAD DIA. (mm)	TORQUE N-m (kgf-m, lbf-ft)	REMARKS
Driven sprocket bolt	4	8	34 (3.5, 25)	
Rear axle nut	1	14	59 (6.0, 44)	
Rear brake arm nut	1	10	10 (1.0, 7)	NOTE 4
Rear brake stopper arm nut (swingarm side)	1	8	22 (2.2, 16)	
Rear brake stopper arm nut (rear brake panel side)	1	8	22 (2.2, 16)	
Shock absorber upper mounting nut	2	10	34 (3.5, 25)	
Shock absorber lower mounting bolt	2	10	34 (3.5, 25)	
Pillion step bracket bolt	2	10	45 (4.6, 33)	
Swingarm pivot nut	1	12	59 (6.0, 44)	

HYDRAULIC BRAKE (Type II, IV)

ITEM	Q'TY	THREAD DIA. (mm)	TORQUE N-m (kgf-m, lbf-ft)	REMARKS
Caliper bleed valve	1	8	5.9 (0.6, 4.4)	
Master cylinder reservoir cap screw	2	4	1.5 (0.2, 1.1)	
Pad pin	2	10	17 (1.7, 13)	
Pad pin plug	2	10	2.5 (0.3, 1.8)	
Brake caliper mounting bolt	2	8	26 (2.7, 19)	NOTE 5
Front brake light switch screw	1	4	1.2 (0.1, 0.9)	
Brake lever pivot bolt	1	6	1.0 (0.1, 0.7)	
Brake lever pivot nut	1	6	5.9 (0.6, 4.4)	
Brake hose oil bolt	2	10	34 (3.5, 25)	

BATTERY/CHARGING SYSTEM

ITEM	Q'TY	THREAD DIA. (mm)	TORQUE N-m (kgf-m, lbf-ft)	REMARKS
Battery holder bolt	2	6	1.8 (0.2, 1.3)	

GENERAL INFORMATION

LIGHTS/METERS/SWITCHES

ITEM	Q'TY	THREAD DIA. (mm)	TORQUE N·m (kgf·m, lbf·ft)	REMARKS
Ignition switch mounting bolt	2	8	24 (2.4, 18)	

OTHERS

ITEM	Q'TY	THREAD DIA. (mm)	TORQUE N·m (kgf·m, lbf·ft)	REMARKS
Clutch lever pivot bolt	1	6	5.9 (0.6, 4.4)	
Clutch lever pivot nut	1	6	1 (0.1, 0.7)	
Brake lever pivot bolt (Type I, III)	1	6	1 (0.1, 0.7)	
Brake lever pivot nut (Type I, III)	1	6	5.9 (0.6, 4.4)	
Side stand pivot bolt	1	10	45(4.6, 33)	

GENERAL INFORMATION

LUBRICATION & SEAL POINTS

ENGINE

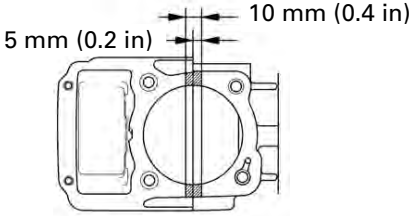
LOCATION	MATERIAL	REMARKS
Oil through sliding area Cylinder sleeve inside area Cylinder head nut threads and seating surface Piston skirt, piston grooves and piston rings Crankshaft big end bearing Flywheel bolt threads and seating surface Oil filter rotor lock nut threads and seating surface Oil pump rotors Valve adjusting lock nut threads and seating surface Engine oil strainer screen cap threads Rocker arm shaft whole surface Starter reduction gear shaft whole surface Starter idle gear shaft whole surface Starter one-way clutch rolling surface Push rod ends Clutch disc surface Cam gear shaft whole surface Push plug spring end surface Oil filter rotor inner surface Clutch lifter rod Primary drive gear whole surface Shift fork shaft whole surface and fork sliding surface Push plug whole surface Each O-rings Each ball bearing and needle bearing Each oil seal lips	Engine oil	
Piston pin whole surface Camshaft lobe, bush and gear surface Cam follower shaft 12 mm O.D. area Each valve stem outer surface Transmission gear teeth, inner surface and shift fork groove surface Kick starter driven gear teeth and inner surface Kick starter pinion gear teeth and inner surface Kick starter idle gear teeth and inner surface	Molybdenum disulfide oil (a mixture of 1/2 engine oil and 1/2 molybdenum disulfide grease)	
Ignition pulse generator socket bolt threads Starter one-way clutch socket bolt	Locking agent	
Cylinder-to-crankcase hatched area  Alternator wire grommet	Liquid sealant (THREE BOND #1141 or equivalent)	
Flywheel mating surface with crankshaft	Degrease	

GENERAL INFORMATION

FRAME

LOCATION	MATERIAL	REMARKS
Steering bearing race and bearing Steering stem dust seal lips	Urea based multi-purpose grease for extreme pressure (example: Shell ALVANIA EP2 or MOBIL MH008) or equivalent	Spread 3.0 g to each bearing race
Front wheel dust seal lip surface Speedometer gear teeth Speedometer gear inner surface Speedometer pinion shaft Speedometer cable (Inside of casing) Front brake cam and shaft surface (Type I, III) Front brake panel anchor pin sliding area (Type I, III) Front brake panel dust seal lip surface (Type I, III) Rear wheel driven flange dust seal lip surface Rear wheel O-ring whole surface Rear brake cam and shaft surface Rear brake panel anchor pin sliding area Brake caliper bracket pin sliding surface (Type II, IV) Side stand pivot sliding area Main stand pivot sliding area Rear brake pedal pivot sliding area Throttle pipe cable contacting area Front brake lever pivot bolt sliding surface (Type I, III) Clutch lever pivot bolt sliding surface Each bearing rotating area	Multi-purpose grease	Inject 3.0 - 5.0 g Spread 0.5 - 1.0 g No grease on lining surface No grease on lining surface No grease on lining surface No grease on lining surface Spread 0.1 g
Front brake cam felt seal whole surface (type I, III) Rear brake cam felt seal whole surface	Gear oil (IDEMITSU AUTOLUB 30 or MECHANIC 44 or equivalent)	
Brake master cylinder cups (Type II, IV) Brake master cylinder piston sliding surface (Type II, IV) Brake caliper piston seal lips (Type II, IV) Brake caliper piston sliding surface (Type II, IV)	DOT 3 or DOT 4 brake fluid	
Throttle cable (Inside of casing) Clutch cable (Inside of casing) Brake cable (Inside of casing) Brake lever pivot sliding surface (Type II, IV) Brake caliper slide pin sliding surface (Type II, IV) Brake caliper dust seal lips Brake master cylinder piston and brake lever contact surface (Type II, IV)	Silicone grease	Spread 0.1 g Spread 0.4 g minimum Spread 0.1 g
Fork socket bolt threads	Locking agent	
Fork cap O-ring Fork slider bushing surface Fork oil seal lips and dust seal lips	Fork fluid	
Handlebar grip inner surface	Honda Bond A or equivalent	

GENERAL INFORMATION

CABLE & HARNESS ROUTING

TYPE I, III:

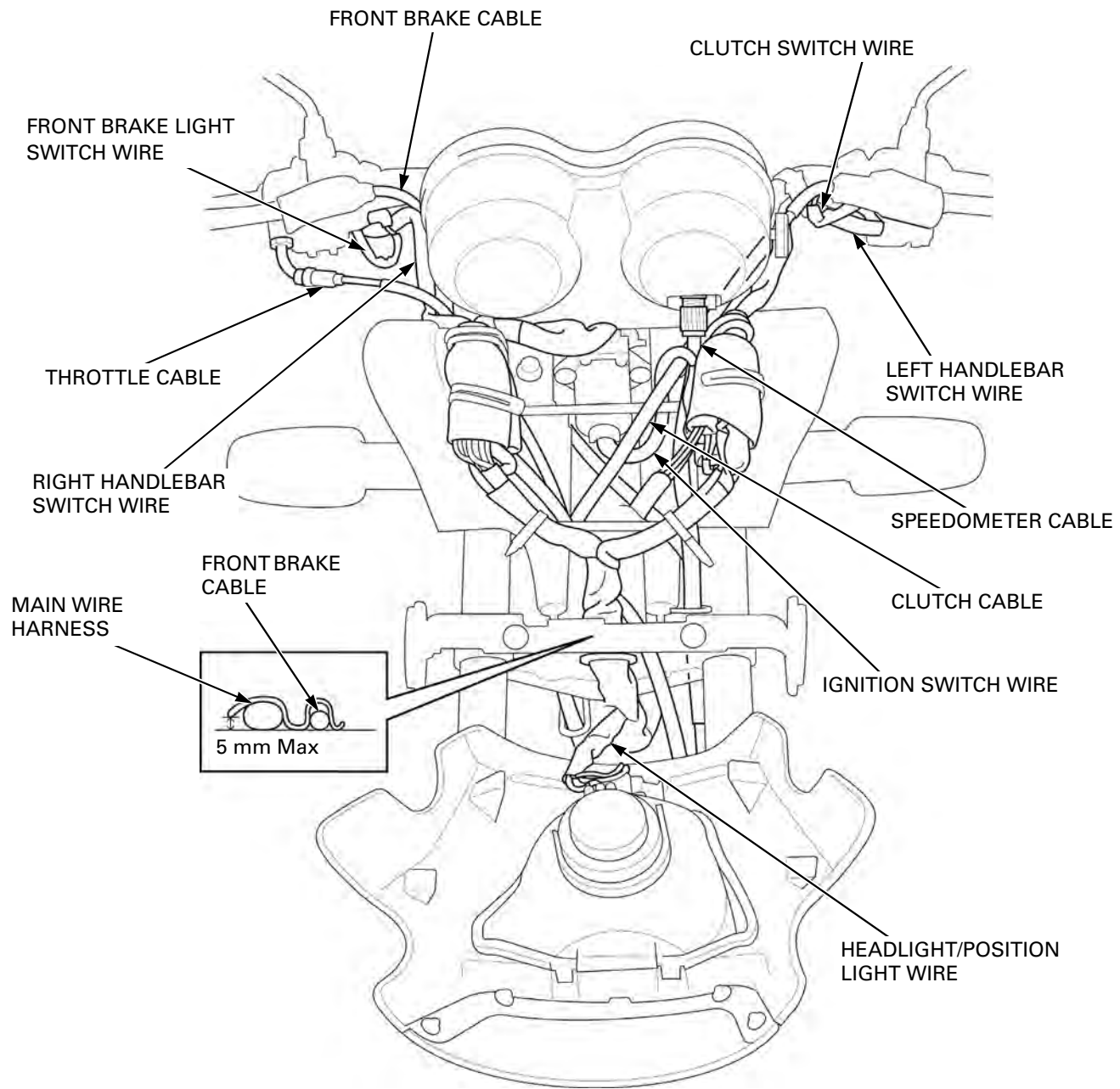

TYPE II, IV:

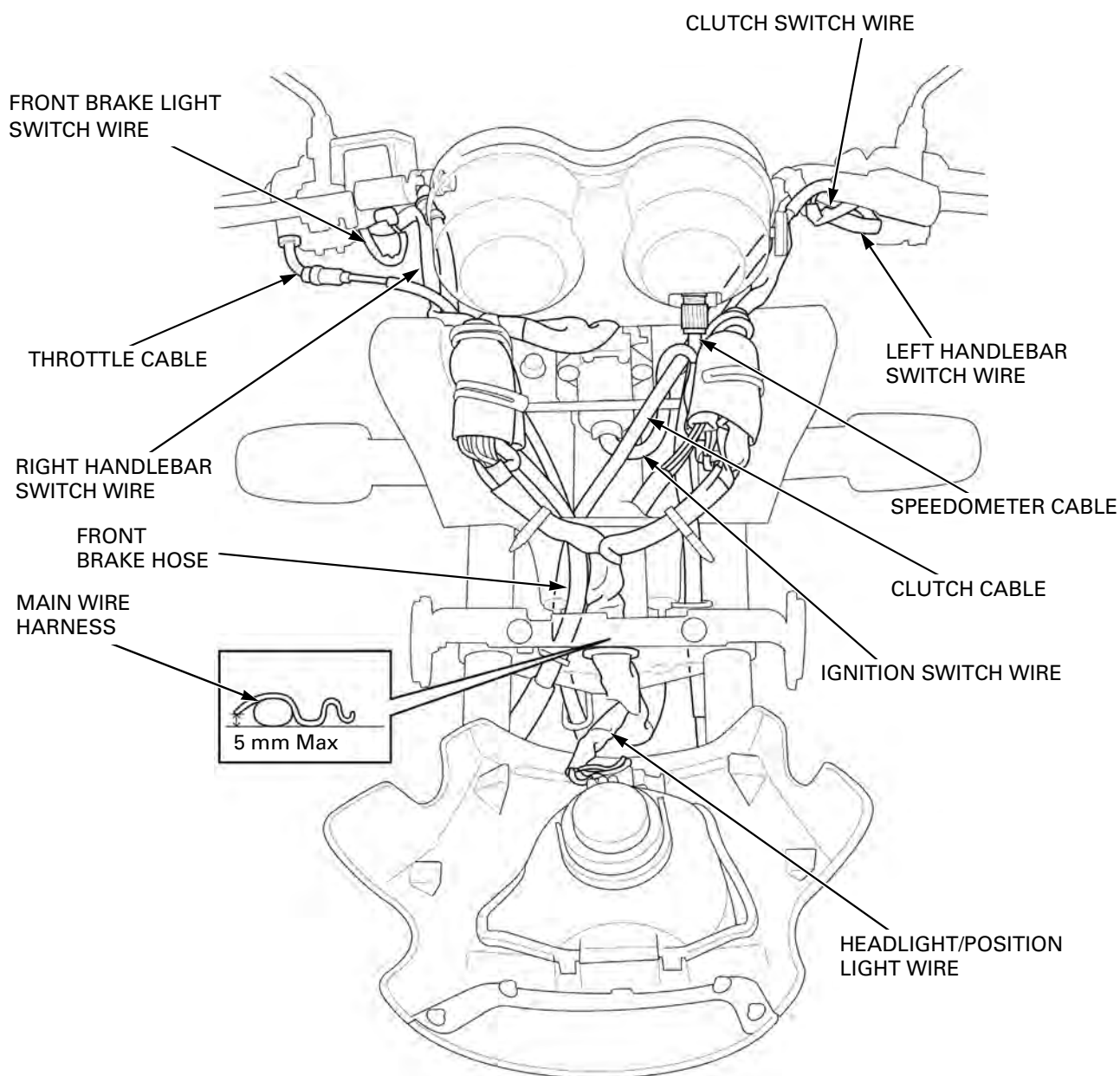

GENERAL INFORMATION

TYPE I, III:

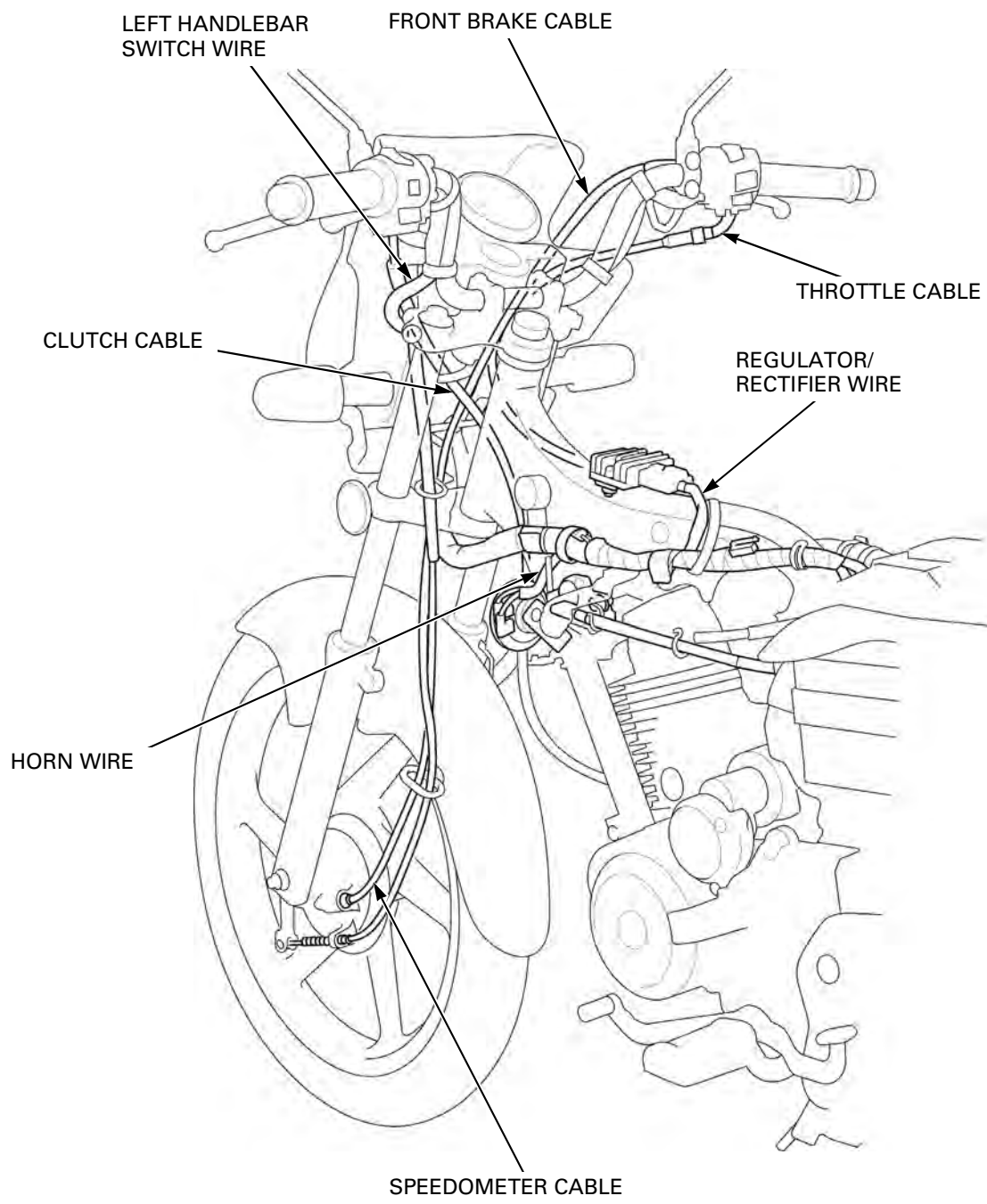

TYPE II, IV:

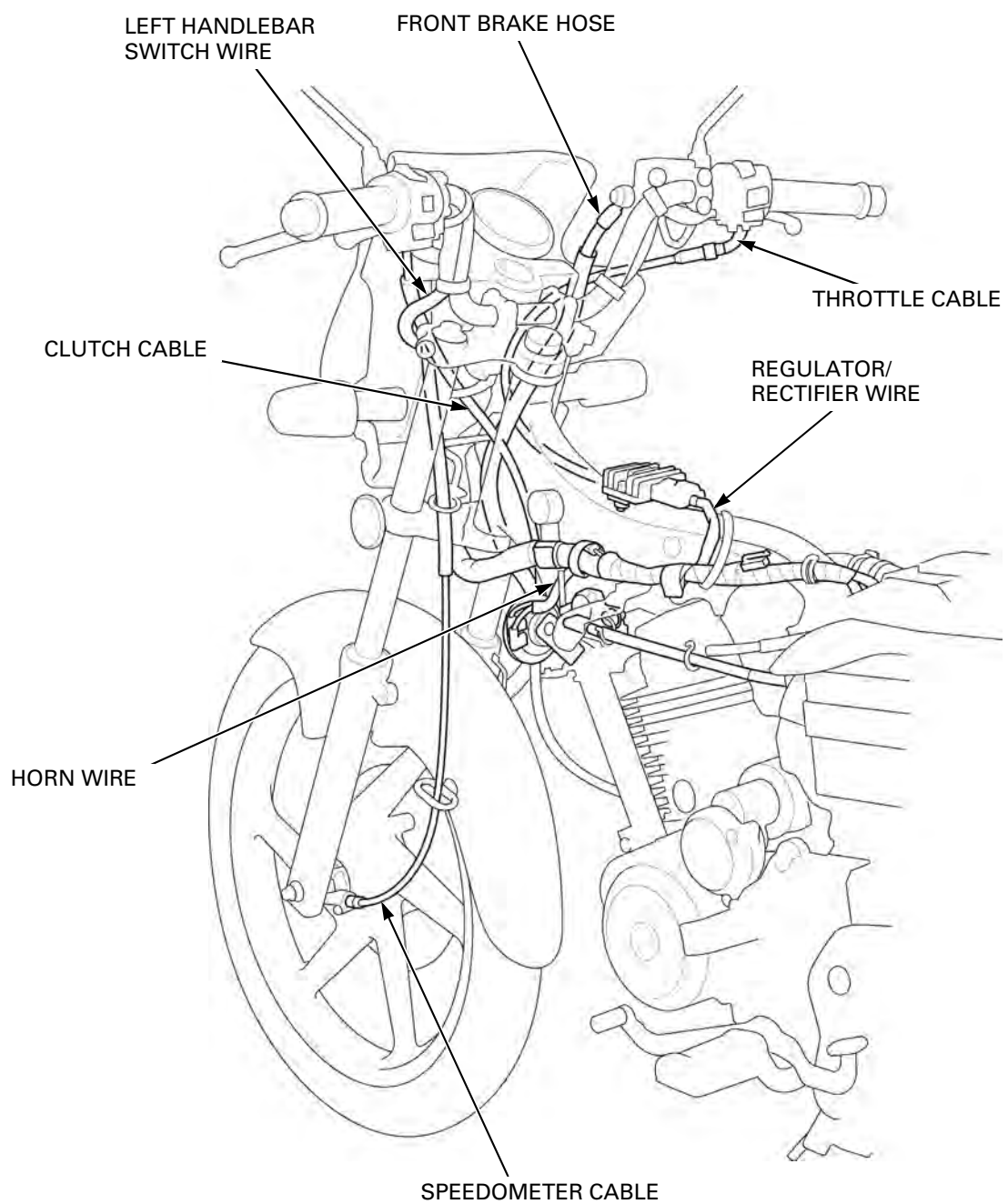

GENERAL INFORMATION

TYPE I, III:

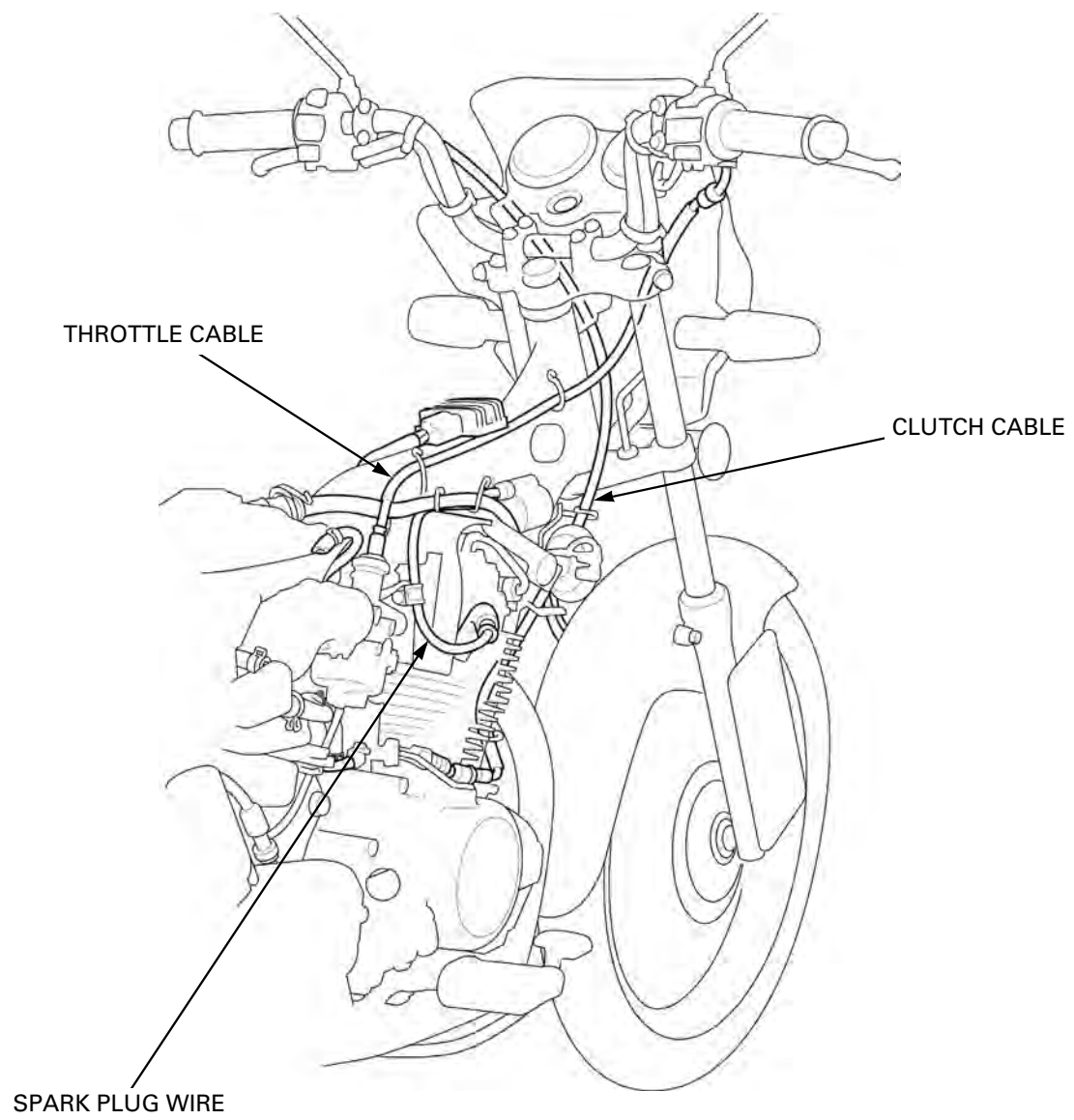

TYPE II, IV:

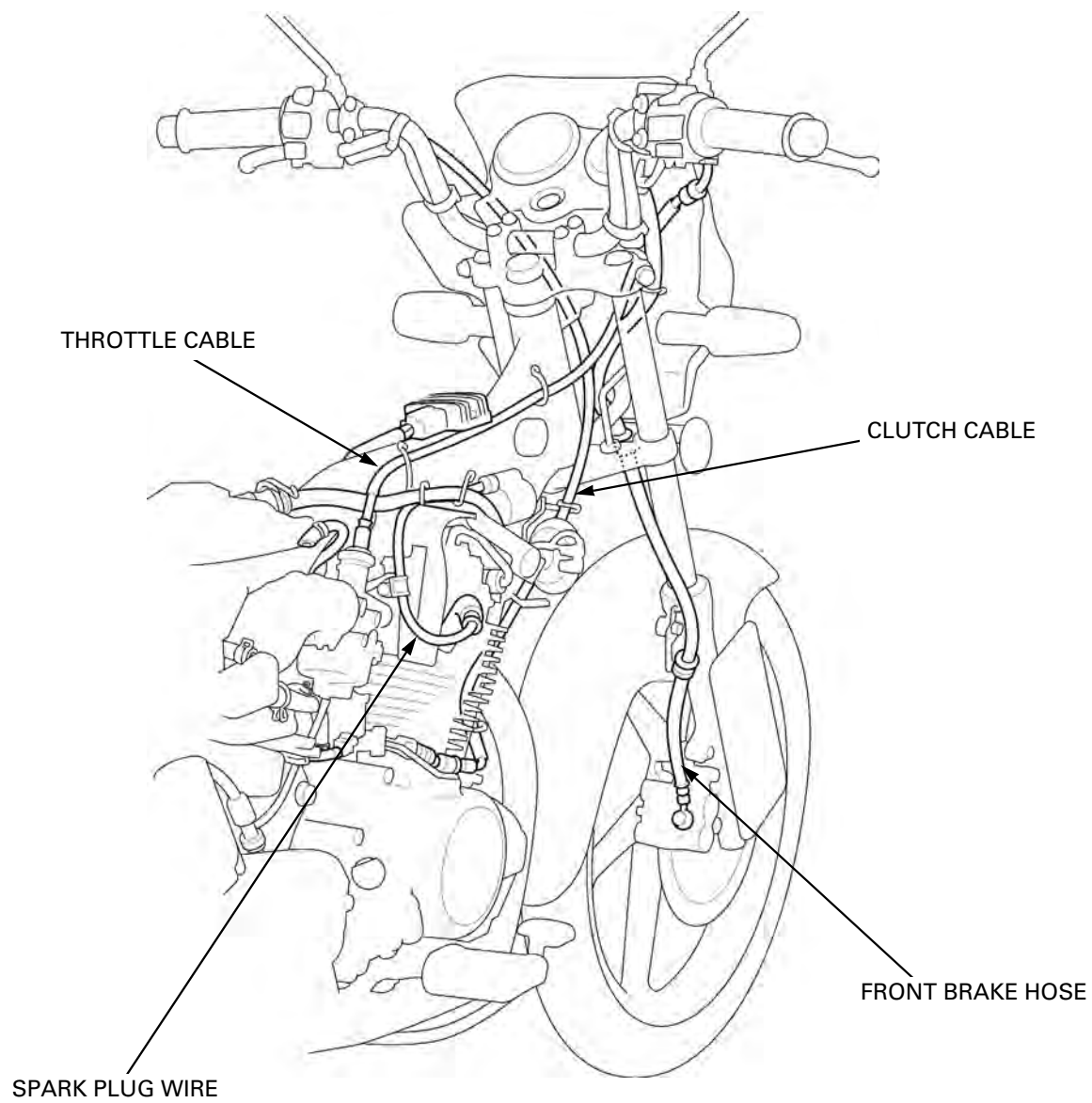

GENERAL INFORMATION

ALL TYPES:

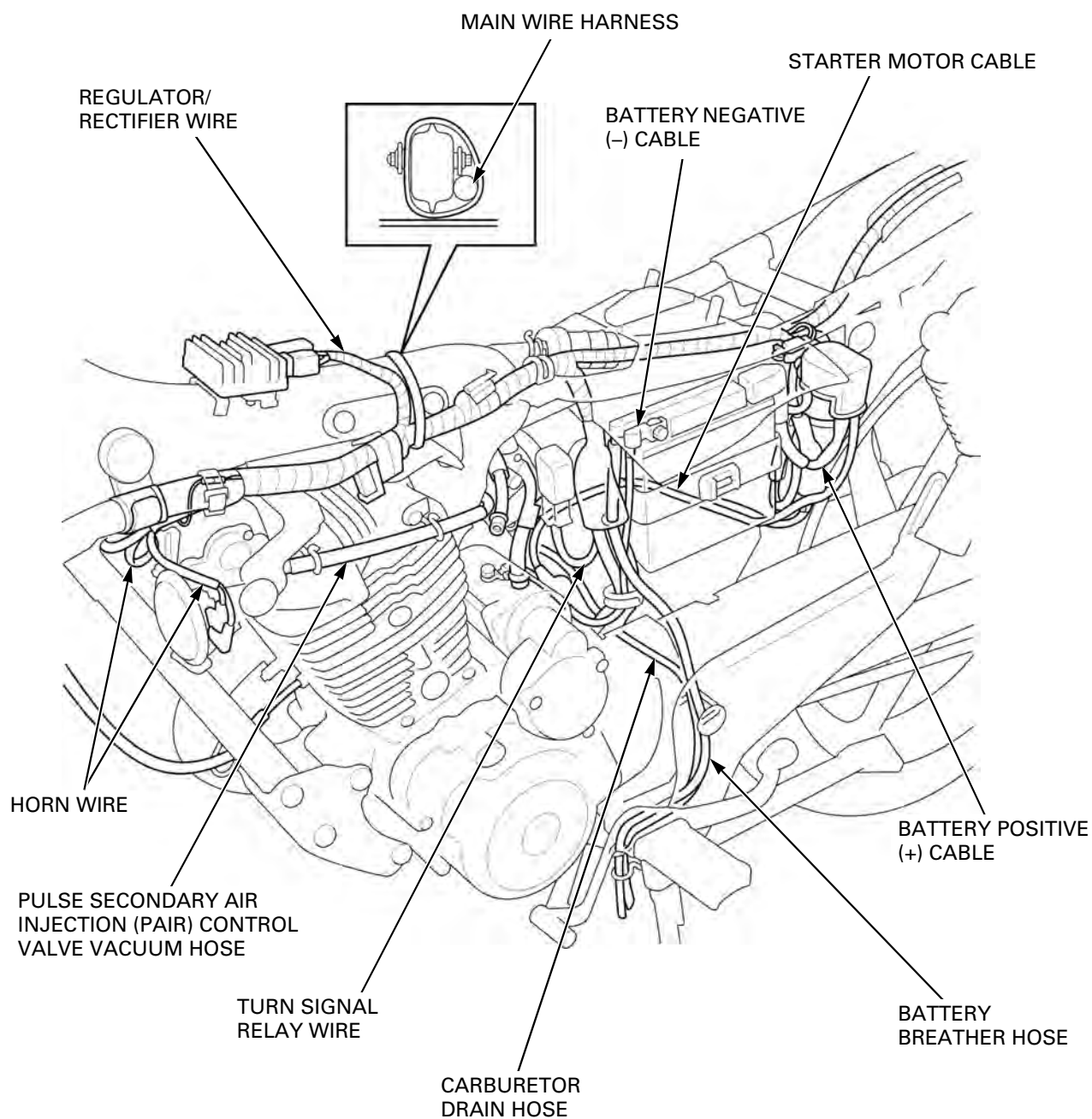

ALL TYPES:

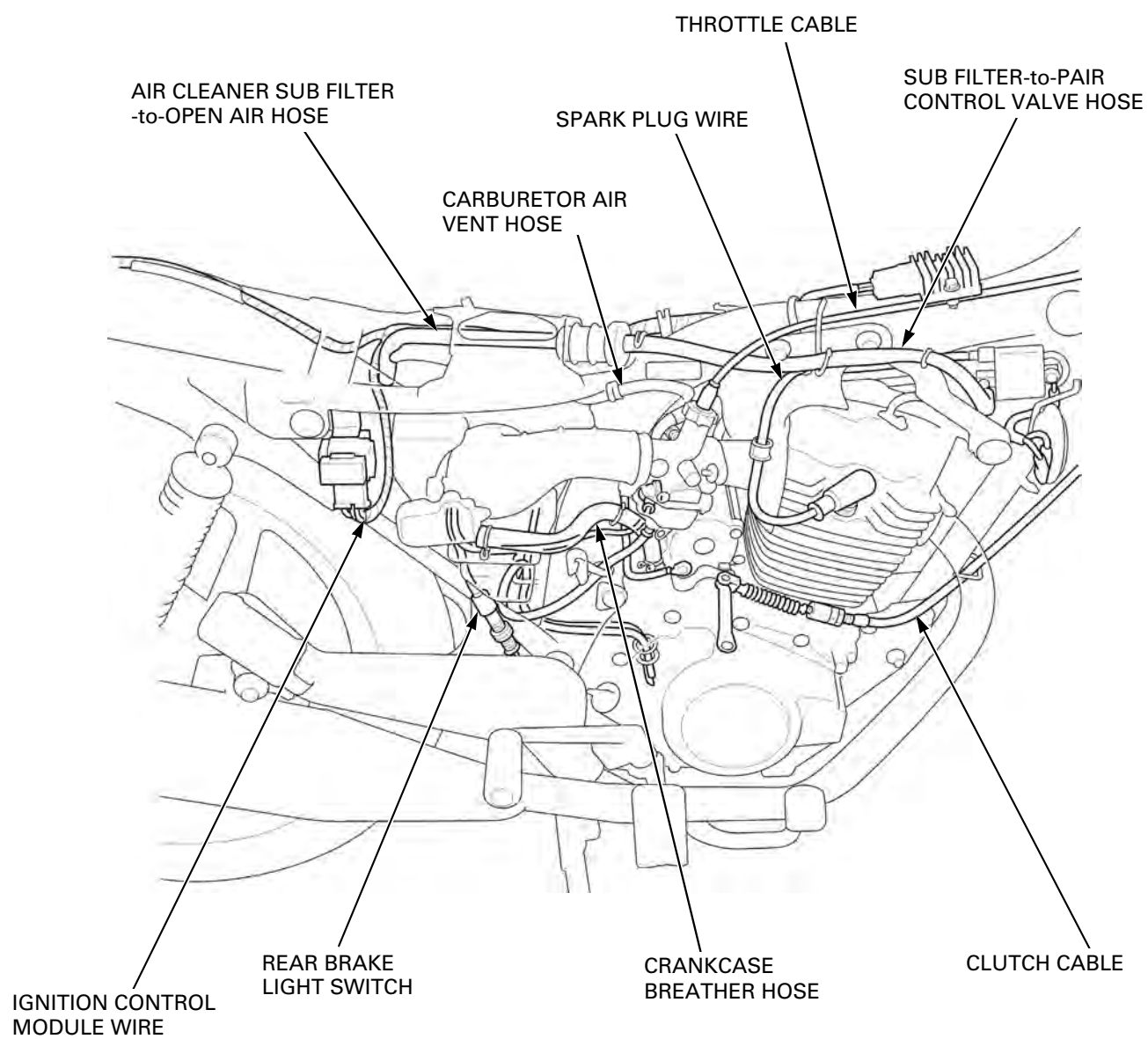

GENERAL INFORMATION

ALL TYPES:

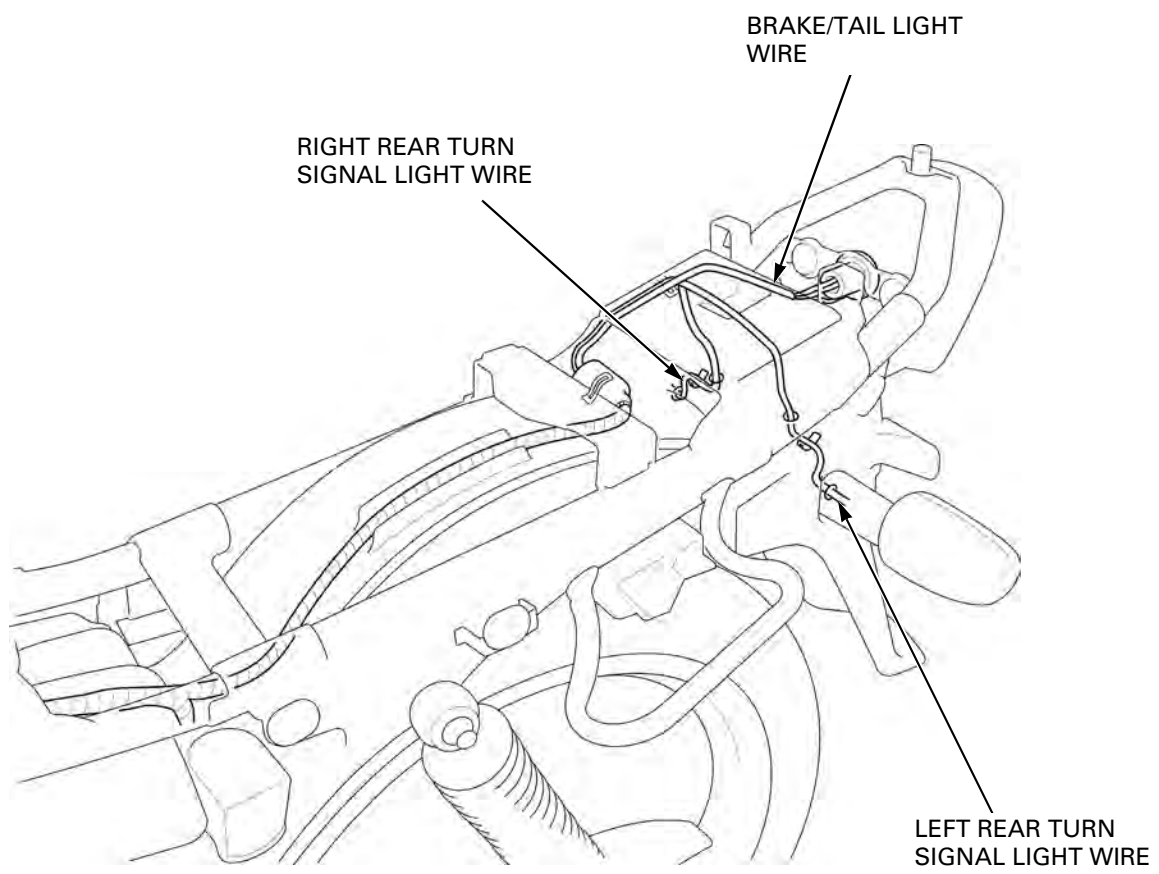

EMISSION CONTROL SYSTEMS

SOURCE OF EMISSIONS

The combustion process produces carbon monoxide and hydrocarbons. Controlling hydrocarbon emission is very important because, under certain conditions, they react to form photochemical smog when subjected to sunlight. Carbon monoxide does not react in the same way, but it is toxic.

Honda Motor Co., Ltd. utilizes lean carburetor settings as well as other systems, to reduce carbon monoxide and hydrocarbons.

CRANKCASE EMISSION CONTROL SYSTEM

The engine is equipped with a closed crankcase system to prevent discharging crankcase emissions into the atmosphere. Blow-by gas is returned to the combustion chamber through the air cleaner and carburetor.

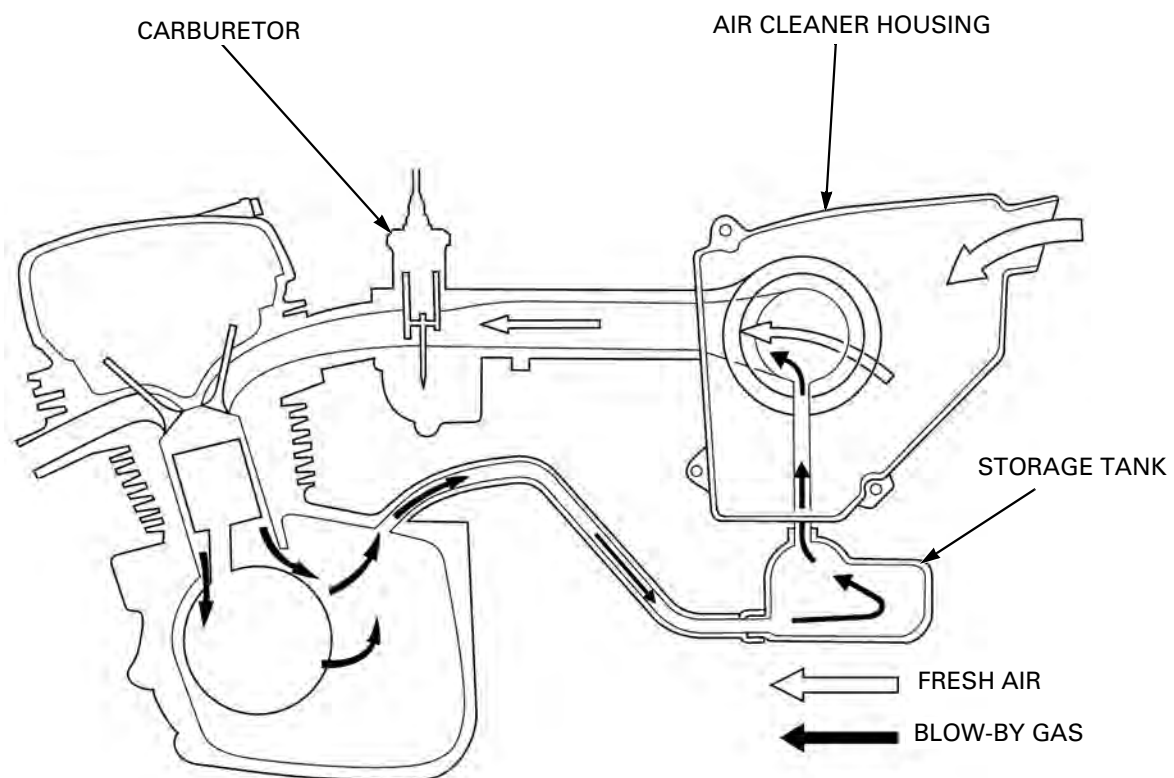

GENERAL INFORMATION

EXHAUST EMISSION CONTROL SYSTEM

The exhaust emission control system is composed of a pulse secondary air injection system and lean carburetor settings, no adjustment should be made except idle speed adjustment with the throttle stop screw.

PULSE SECONDARY AIR INJECTION SYSTEM

The pulse secondary air injection (PAIR) system introduces filtered air into the exhaust gases in the exhaust port. Fresh air is drawn into the exhaust port by the function of the PAIR (Pulse Secondary Air Injection) control valve.

The reed valve prevents reverse air flow through the system. The PAIR control valve reacts to high intake manifold vacuum and will cut off the supply of fresh air during engine deceleration, thereby preventing afterburn in the exhaust system.

No adjustments to the secondary air supply system should be made, although periodic inspection of the components is recommended.

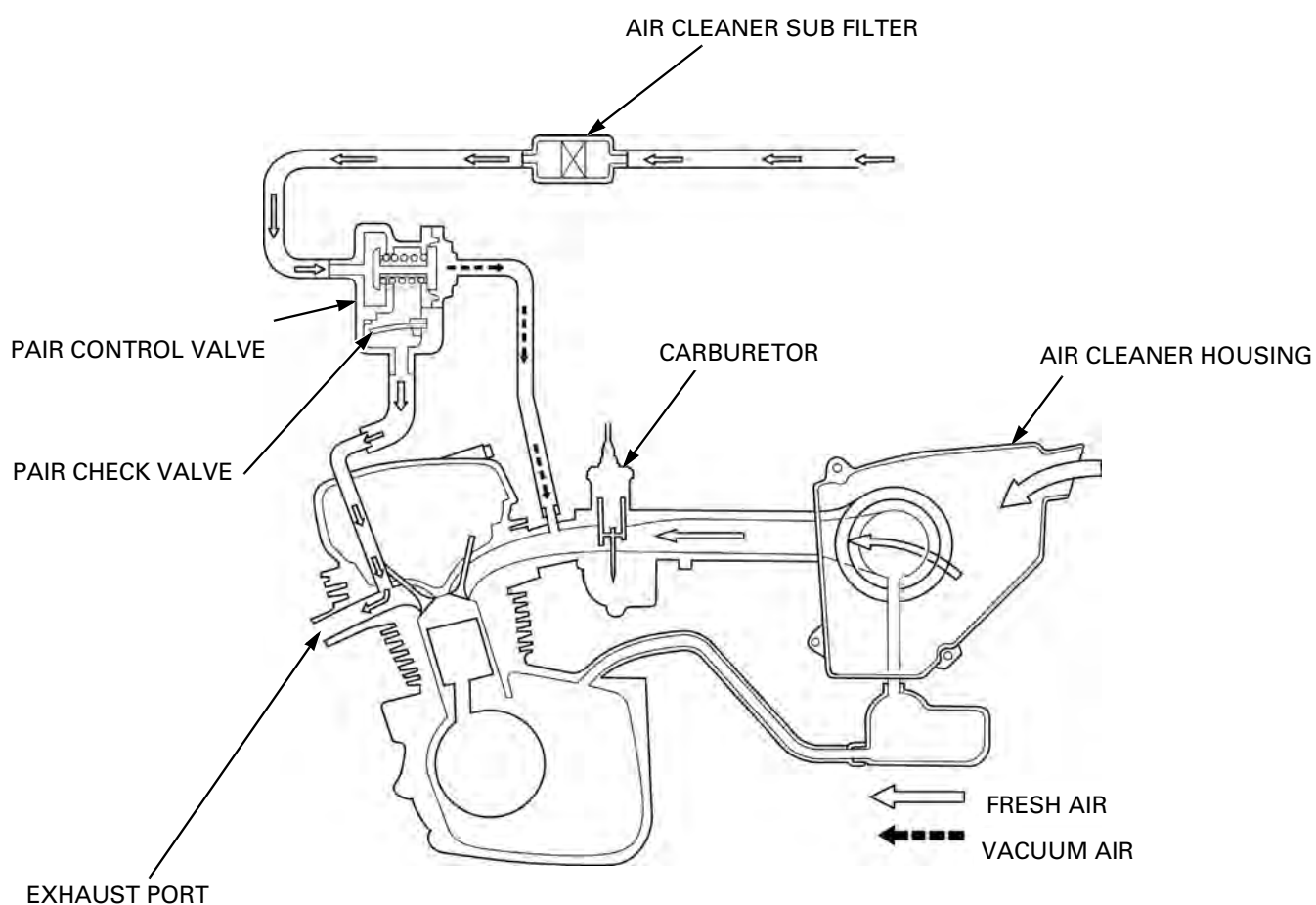

2. FRAME/BODY PANELS/EXHAUST SYSTEM

SERVICE INFORMATION	2-2	REAR FENDER	2-6
TROUBLESHOOTING	2-2	FRONT FENDER.....	2-6
SIDE COVERS	2-3	FRONT COWL	2-7
SEAT.....	2-4	HORN COVER.....	2-7
FUEL TANK	2-4	FOOTPEG BAR.....	2-8
REAR CARRIER	2-5	LICENSE PLATE HOLDER	2-8
REAR COWL.....	2-5	EXHAUST PIPE/MUFFLER.....	2-8

FRAME/BODY PANELS/EXHAUST SYSTEM

SERVICE INFORMATION

GENERAL

- This section covers removal and installation of the body panels, fuel tank and exhaust system.
- Place the motorcycle on level ground before starting any work.
- Always replace the exhaust pipe gaskets after removing the exhaust pipe from the engine.
- When installing the exhaust system, loosely install all of the fasteners. Always tighten the exhaust clamp and joint first, then tighten the mounting fasteners. If you tighten the mounting fasteners first, the exhaust pipe may not seat properly.
- Always inspect the exhaust system for leaks after installation.

TORQUE VALUES

Exhaust pipe joint nut	20 N·m (2.0 kgf·m, 15 lbf·ft)
Footpeg bar mounting bolt	27 N·m (2.8 kgf·m, 20 lbf·ft)

TROUBLESHOOTING

Excessive exhaust noise

- Broken exhaust system
- Exhaust gas leak

Poor performance

- Deformed exhaust system
- Exhaust gas leak
- Clogged muffler

SIDE COVERS

RIGHT SIDE COVER REMOVAL/ INSTALLATION

Unlock the right side cover with the ignition key by turning it clockwise.

Be careful not to damage the side cover bosses.

Release three side cover bosses from the grommets of the frame and fuel tank, remove the right side cover.

Installation is in the reverse order of removal.

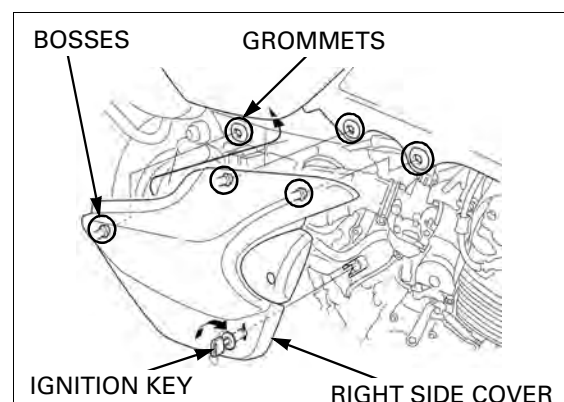

LEFT SIDE COVER REMOVAL/ INSTALLATION

Unlock the left side cover with the ignition key by turning it clockwise.

Be careful not to damage the side cover bosses.

Release three side cover bosses from the grommets of the frame and fuel tank, remove the left side cover.

Installation is in the reverse order of removal.

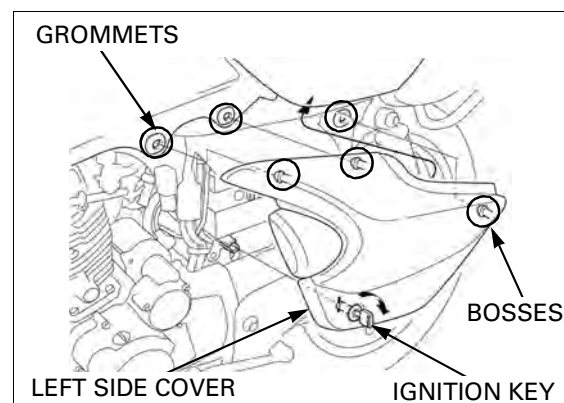

DISASSEMBLY/ASSEMBLY

Be careful not to damage the bosses when removing the carburetor cover.

Remove three screws and the carburetor cover from the side cover.

Remove the retainer spring and the key cylinder from the side cover.

Insert the key cylinder to the side cover and install the retainer spring by aligning the slots on the side of the key cylinder with the spring.

Install the carburetor cover by aligning three bosses with the holes of carburetor cover and tighten three screws.

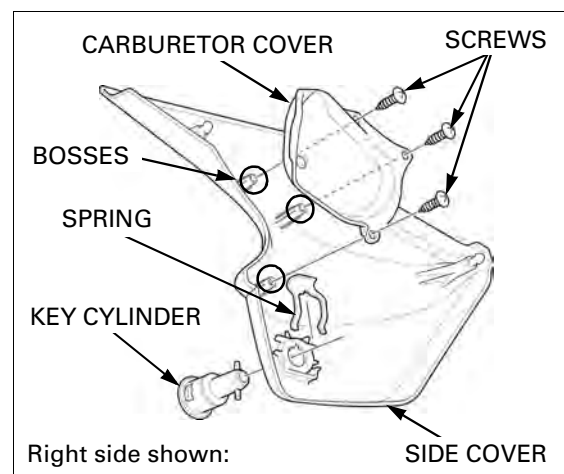

FRAME/BODY PANELS/EXHAUST SYSTEM

SEAT

REMOVAL/INSTALLATION

Remove the two seat mounting bolts. Slide the seat backward, release the hooks from the hole and remove it.

Install the seat by aligning the hooks with the hole of the frame, press down the seat and slide it forward.

Install and tighten two seat mounting bolts.

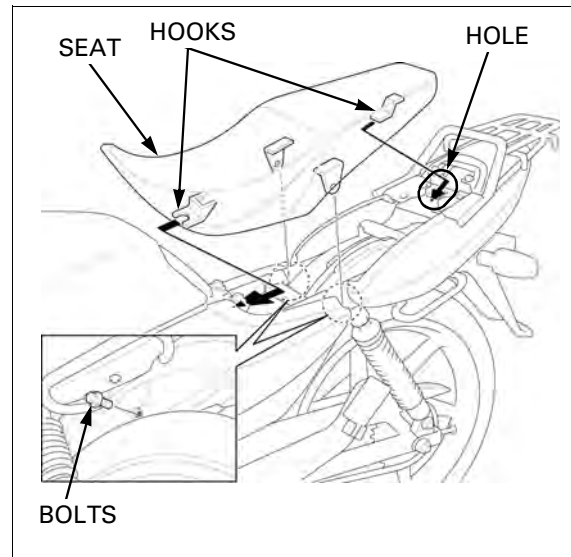

FUEL TANK

REMOVAL/INSTALLATION

Remove the following:

- Right and left side covers (page 2-3)
- Seat (page 2-4)

Wipe the spilled gasoline off immediately.

Turn the fuel valve "OFF" and disconnect the fuel hose.

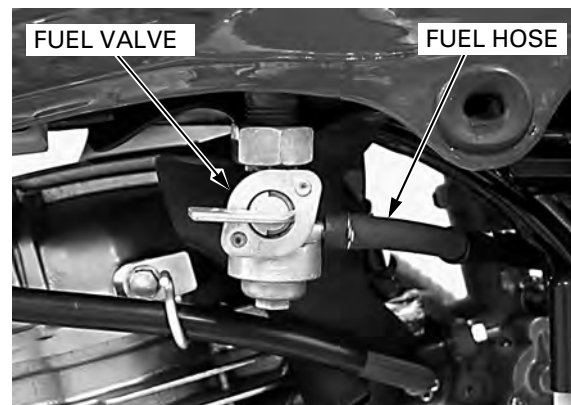

Remove the two fuel tank mounting bolts.

Release the grommets of the fuel tank from the bosses of the frame and pull the fuel tank backward. Release the fuel unit wire from the clamp of the frame and disconnect the fuel unit 2P connector, then remove the fuel tank

After installation, turn the fuel valve "ON" and make sure that there are no fuel leaks.

Installation is in the reverse order of removal.

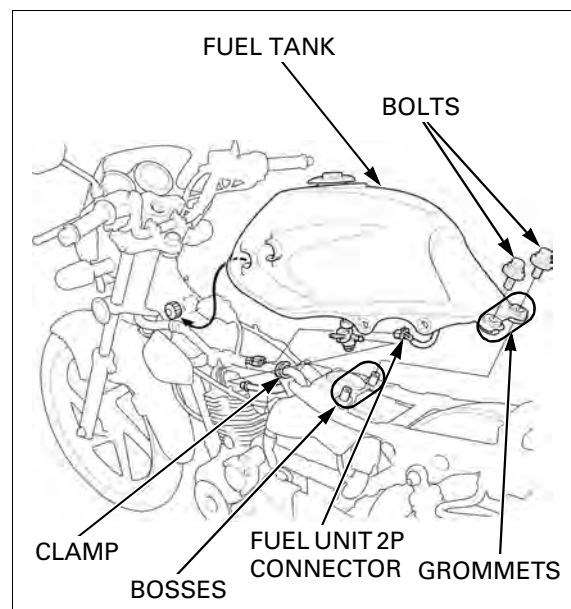

REAR CARRIER

REMOVAL/INSTALLATION

Remove the seat (page 2-4).

Remove the five bolts and the rear carrier.

Align the bolt holes of the rear carrier and the bolt holes of the frame.

Install and tighten the five bolts.

Install the seat (page 2-4).

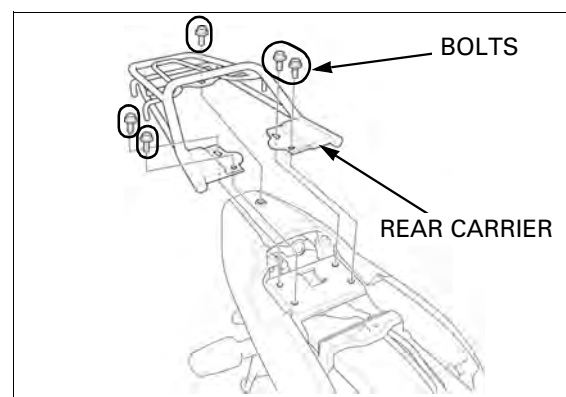

REAR COWL

REMOVAL/INSTALLATION

Remove the rear carrier (page 2-5).

Remove the two rear cowl mounting screws from the bottom of the rear cowl and two bolts/collars/grommets from the top of the rear cowl.

Be careful not to break the bosses when removing the rear cowl.

Release the two round bosses of the right/left rear cowl from the grommets of the frame first, then release the two flat bosses from the grommets of the rear fender.

Release the boss of the frame from the rear center cowl grommet and remove the rear cowl and the washers.

Installation is in the reverse order of removal.

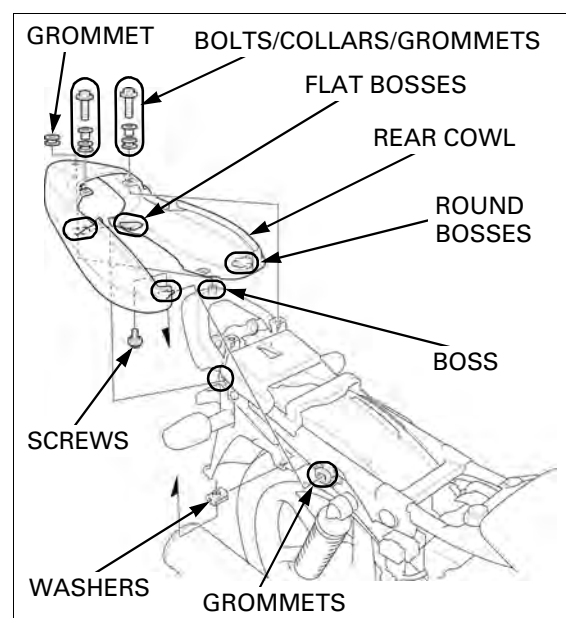

DISASSEMBLY/ASSEMBLY

Remove the four screws from the rear cowl.

Be careful not to break the bosses and the tabs when separating the cowls.

Separate the rear cowl by releasing the two bosses and the two tabs of the center cowl from the right and left rear cowls.

Assembly is in the reverse order of disassembly.

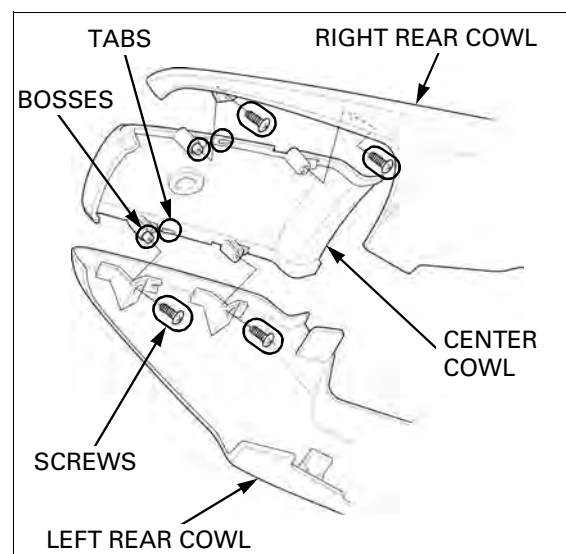

FRAME/BODY PANELS/EXHAUST SYSTEM

REAR FENDER

REMOVAL/INSTALLATION

Remove the rear cowl (page 2-5).

Disconnect the four turn signal light wire connectors.

Remove three bolts and release the boss of the tail-light unit from the grommet of the rear fender by slightly pulling the rear fender down.

Be careful not to damage the hooks when removing the rear fender.

Release the hooks of the rear fender from the frame and remove the rear fender by pulling it backward.

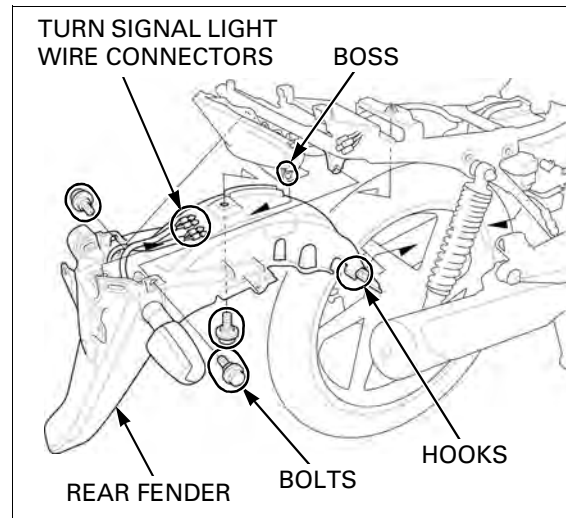

Remove the two bolts/washers from the rear turn signal mounting bracket and two turn signal unit mounting nuts.

Pull out the rear turn signal wires from the upper holes of the rear fender, nuts, rear turn signal mounting bracket and the lower holes of the rear fender and remove the rear turn signal units.

Route the turn signal wires properly (page 1-24).

Installation is in the reverse order of removal.

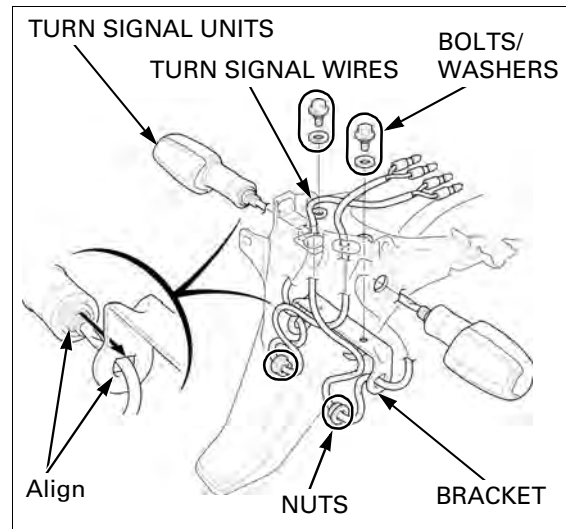

FRONT FENDER

REMOVAL/INSTALLATION

Remove the cable guide from the front fender.

Remove the four bolts, collars, grommets and the brake hose clamp.

Pull up and remove the front fender and front fender stay.

Check the speedometer operation and the front brake operation after installation.

Installation is in the reverse order of removal.

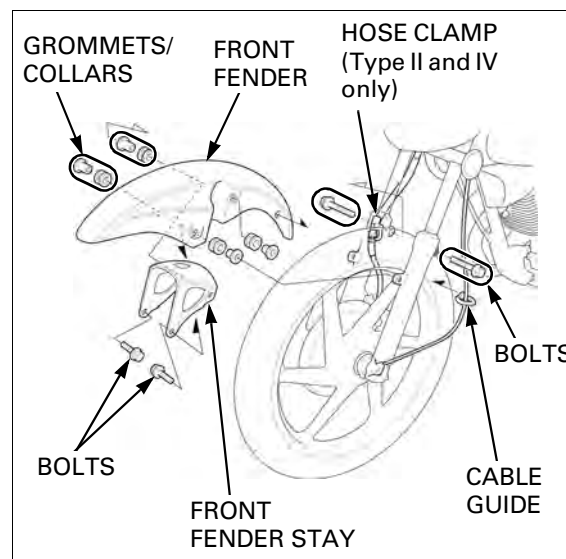

FRONT COWL

REMOVAL/INSTALLATION

Hold the front cowl when removing the bolts and disconnecting the connector.

Remove the four bolts, disconnect the headlight 4P connector and remove the front cowl.

Installation is in the reverse order of removal.

Check the headlight aim (page 3-18).

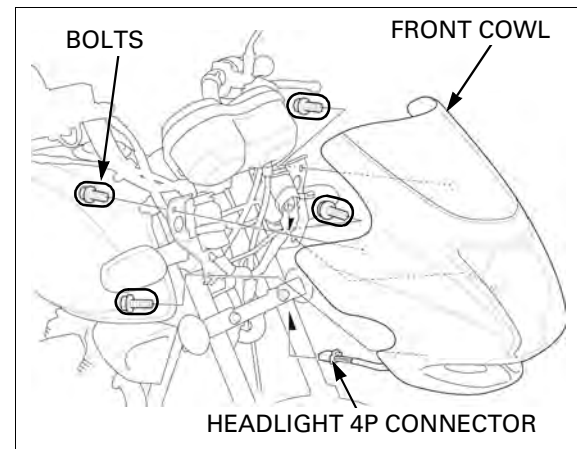

DISASSEMBLY/ASSEMBLY

Remove the headlight aim adjusting bolt/washer, two retainer springs and headlight unit by releasing the tabs of the headlight unit from the slots of the front cowl.

Be careful not to damage the front visor surface.

Remove the four set screws and plastic washers, release the tab of the front visor from the front cowl and remove the visor.

Remove the four nuts from the front cowl.

Do not tighten the set screws too much.

Install the four nuts to the front cowl.

Install the visor by aligning the tab of the visor with the slot of the front cowl and tighten the four set screws until the setting nuts are squeezed as shown.

Install the headlight unit by aligning the two tabs of the headlight unit with the slots of the front cowl and install the two retainer springs.

Install the headlight aim adjusting bolt/washer.

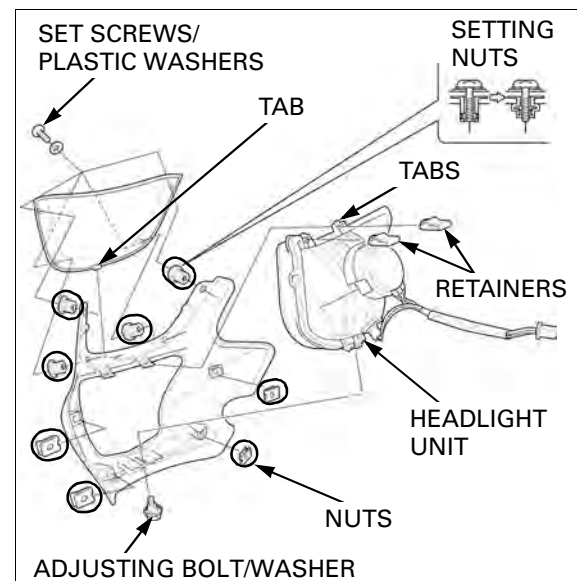

HORN COVER

REMOVAL/INSTALLATION

Remove the horn cover mounting bolt and washer.

Be careful not to damage the horn cover boss.

Release the boss of the horn cover from the grommet of the horn cover stay.

Unhook the horn cover mounting rubber from the hook and remove the horn cover.

Installation is in the reverse order of removal.

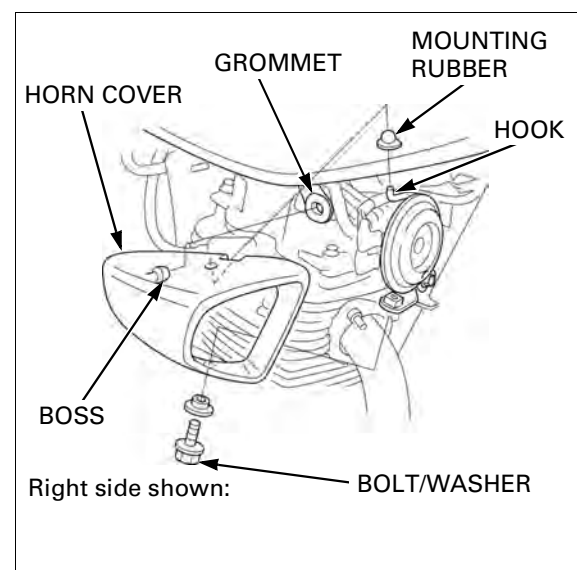

FRAME/BODY PANELS/EXHAUST SYSTEM

FOOTPEG BAR

REMOVAL/INSTALLATION

Remove the exhaust pipe/muffler (page 2-8).

Remove the four footpeg bar mounting bolts and washers.

Pull down the rear brake pedal and remove the footpeg bar from the engine.

Install the footpeg bar, washers and mounting bolts and tighten them to the specified torque.

TORQUE: 27 N·m (2.8 kgf·m, 20 lbf·ft)

Install the exhaust pipe/muffler (page 2-9).



LICENSE PLATE HOLDER

REMOVAL/INSTALLATION

Remove the two bolts and the license plate holder.

Installation is in the reverse order of removal.

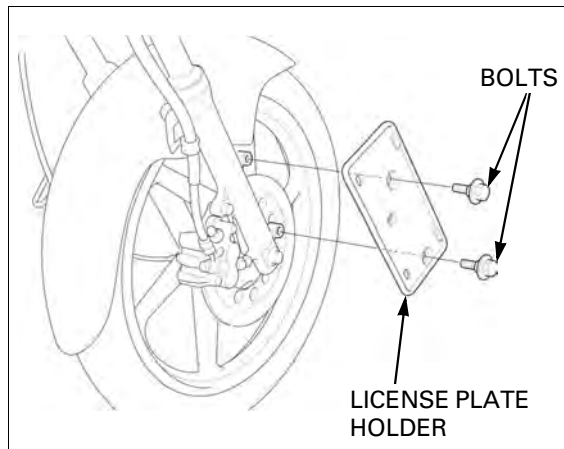

EXHAUST PIPE/MUFFLER

REMOVAL

Loosen the muffler mounting bolt/nut, then loosen the exhaust pipe joint nuts.

Remove the muffler mounting bolt/washer/nut and the two exhaust pipe joint nuts.

Remove the exhaust pipe/muffler and the joint collars.

Remove the gasket.

Remove the screws, grommet and the muffler protector.

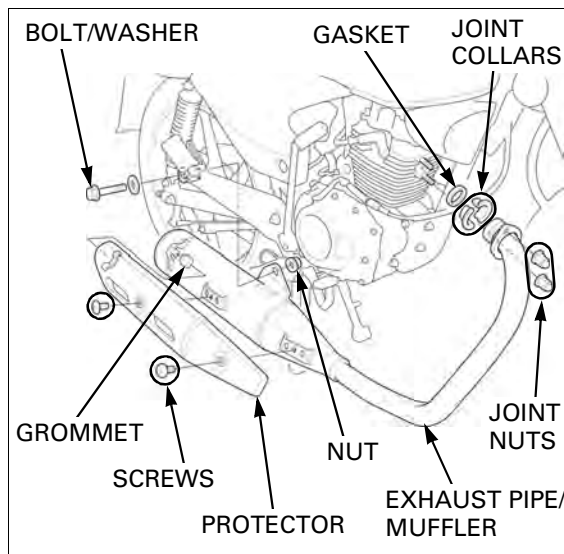

INSTALLATION

Always replace the exhaust pipe gasket with a new one when removing the exhaust pipe from the engine.

Install a new gasket into the exhaust port.



Set the joint collars in the exhaust port and install the exhaust pipe/muffler.
Loosely install the exhaust pipe joint nuts.

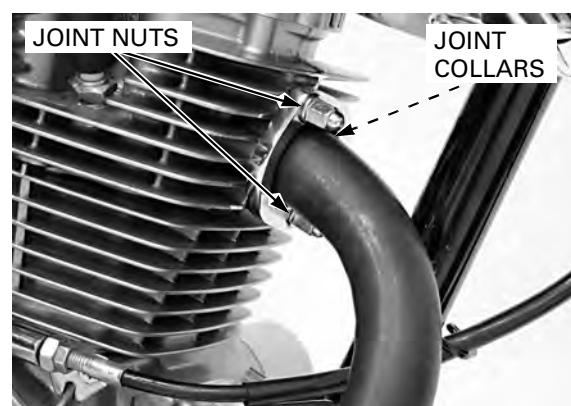

Loosely install the muffler mounting bolt/washer/nut.
Tighten the exhaust pipe joint nuts to the specified torque.

TORQUE: 20 N·m (2.0 kgf·m, 15 lbf·ft)

Always inspect the exhaust system for leaks after installation.

Tighten the muffler mounting nut.



MEMO

3. MAINTENANCE

SERVICE INFORMATION	3-2	BATTERY.....	3-14
MAINTENANCE SCHEDULE	3-3	BRAKE FLUID (TYPE II, IV).....	3-14
FUEL LINE	3-4	BRAKE SHOES WEAR (TYPE I, III)	3-15
FUEL STRAINER SCREEN.....	3-4	BRAKE SHOES/PADS WEAR (TYPE II, IV).....	3-16
THROTTLE OPERATION.....	3-5	BRAKE SYSTEM	3-16
AIR CLEANER.....	3-6	BRAKE LIGHT SWITCH	3-18
SPARK PLUG	3-7	HEADLIGHT AIM	3-18
VALVE CLEARANCE.....	3-8	CLUTCH SYSTEM.....	3-18
ENGINE OIL.....	3-9	SIDE STAND	3-19
ENGINE OIL STRAINER SCREEN	3-10	SUSPENSION	3-19
ENGINE IDLE SPEED	3-11	NUTS, BOLTS, FASTENERS.....	3-20
SECONDARY AIR SUPPLY SYSTEM.....	3-11	WHEELS/TIRES	3-20
DRIVE CHAIN.....	3-12	STEERING HEAD BEARINGS	3-21

MAINTENANCE

SERVICE INFORMATION

GENERAL

- Place the motorcycle on level surface before starting any work.
- The exhaust contains poisonous carbon monoxide gas that may cause loss of consciousness and may lead to death. Run the engine in an open area or with an exhaust evacuation system in an enclosed area.

SPECIFICATIONS

ITEM		SPECIFICATIONS	
Throttle grip free play		2.0 – 6.0 mm (0.08 – 0.24 in)	
Spark plug	Standard	DPR8EA-9 (NGK)	
	For extended high speed riding	DPR9EA-9 (NGK)	
Spark plug gap		0.80 – 0.90 mm (0.031 – 0.035 in)	
Valve clearance	IN/EX	0.08 ± 0.02 mm (0.003 ± 0.001 in)	
Engine oil capacity	After draining	0.8 liter (0.8 US qt, 0.7 Imp qt)	
	After disassembly	1.1 liter (1.2 US qt, 1.0 Imp qt)	
Recommended engine oil		Honda 4-stroke oil or equivalent motor oil API service classification: SF or SG Viscosity: SAE 10W-30	
Idle speed		1,400 ± 100 min ⁻¹ (rpm)	
Drive chain slack		10 – 20 mm (0.4 – 0.8 in)	
Drive chain size/link		428/108	
Recommended brake fluid (Type II, IV)		DOT 3 or DOT 4	
Brake lever free play (Type I, III)		10 – 20 mm (0.4 – 0.8 in)	
Brake pedal free play		20 – 30 mm (0.8 – 1.2 in)	
Clutch lever free play		10 – 20 mm (0.4 – 0.8 in)	
Tire size	Front	80/100 – 18 M/C 47P	
	Rear	90/90 – 18 M/C 51P	
Cold tire pressure	Driver only	Front	200 kPa (2.00 kgf/cm ² , 29 psi)
		Rear	225 kPa (2.25 kgf/cm ² , 33 psi)
	Driver and passenger	Front	200 kPa (2.00 kgf/cm ² , 29 psi)
		Rear	225 kPa (2.25 kgf/cm ² , 33 psi)
Minimum tire tread depth (front/rear)		To wear indicator	

TORQUE VALUES

Air cleaner housing cover screw	1.8 N·m (0.2 kgf·m, 1.3 lbf·ft)
Spark plug	18 N·m (1.8 kgf·m, 13 lbf·ft)
Oil drain bolt	24 N·m (2.4 kgf·m, 18 lbf·ft)
Oil strainer screen cap	15 N·m (1.5 kgf·m, 11 lbf·ft)
Valve adjusting lock nut	14 N·m (1.4 kgf·m, 10 lbf·ft)
Timing hole cap	6 N·m (0.6 kgf·m, 4.4 lbf·ft)
Crankshaft hole cap	8 N·m (0.8 kgf·m, 5.9 lbf·ft)
Master cylinder reservoir cap screw	1.5 N·m (0.2 kgf·m, 1.1 lbf·ft)
Rear axle nut	59 N·m (6.0 kgf·m, 44 lbf·ft)

Apply oil to the threads and seating surface.
Apply oil to the threads and seating surface.

TOOLS

Valve adjusting wrench
07908-KE90000



MAINTENANCE SCHEDULE

Perform the Pre-ride inspection in the Owner's Manual at each scheduled maintenance period.

I: Inspect and Clean, Adjust, Lubricate or Replace if necessary.

C: Clean. R: Replace. A: Adjust. L: Lubricate.

The following items require some mechanical knowledge. Certain items (particularly those marked * and **) may require more technical information and tools. Consult their authorized Honda dealer.

ITEMS	FREQUENCY	WHICHEVER COMES FIRST ↓ NOTE	ODOMETER READING (NOTE 1)				REFER TO PAGE		
			x 1,000 mi	0.6	2.5	5		7.5	
			x 1,000 km	1	4	8		12	
			MONTHS		6	12	18		
* FUEL LINE					I	I	I		3-4
* FUEL STRAINER SCREEN					C	C	C		3-4
* THROTTLE OPERATION					I	I	I		3-5
AIR CLEANER		NOTE 2			C	C	R		3-6
SPARK PLUG					I	R	I		3-7
* VALVE CLEARANCE					I	I	I	I	3-8
ENGINE OIL				R	EVERY 3,000 km (2000 mi) R				3-9
* ENGINE OIL STRAINER SCREEN							C		3-10
* ENGINE IDLE SPEED					I	I	I	I	3-11
* SECONDARY AIR SUPPLY SYSTEM		NOTE 5					I		3-11
DRIVE CHAIN		NOTE 3			EVERY 1,000 km (600 mi) I, L				3-12
BATTERY					EVERY 2,000 km (1250 mi) I				3-14
BRAKE FLUID (TYPE II, IV)		NOTE 4			I	I	I		3-14
BRAKE SHOES WEAR (TYPE I, III)					I	I	I		3-15
BRAKE SHOES/PADS WEAR (TYPE II, IV)					I	I	I		3-16
BRAKE SYSTEM					I	I	I	I	3-16
* BRAKE LIGHT SWITCH					I	I	I		3-18
* HEADLIGHT AIM					I	I	I	I	3-18
CLUTCH SYSTEM					I	I	I	I	3-18
SIDE STAND					I	I	I	I	3-19
* SUSPENSION					I	I	I	I	3-19
* NUTS, BOLTS, FASTENERS		NOTE 3			I		I		3-20
** WHEELS/TIRES					I	I	I	I	3-20
** STEERING HEAD BEARINGS					I		I	I	3-21

* Should be serviced by an authorized Honda dealer, unless the owner has proper tools and service data and is mechanically qualified. Refer to the official Honda shop manual.

** In the interest of safety, we recommended these items be serviced only by an authorized Honda dealer.

Honda recommends that the Honda dealer should road test the motorcycle after each periodic maintenance is carried out.

NOTES:

1. At higher odometer reading, repeat at the frequency interval established here.
2. Service more frequently when riding in unusually wet or dusty areas.
3. Service more frequently when riding OFF-ROAD.
4. Replace every 2 years. Replacement requires mechanical skill.
5. Replace every 3 years or 24,000 km (15,000 mi). Replacement requires mechanical skill.

MAINTENANCE

FUEL LINE

Inspect the fuel line for crack, damage or leak.

Clean or replace if necessary.

If the fuel flow is restricted, inspect the fuel line and fuel strainer for blockage.

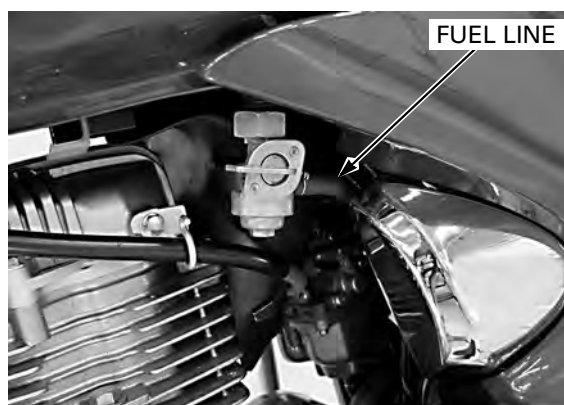

FUEL STRAINER SCREEN

Turn the fuel valve "OFF".

Remove the fuel strainer cup and drain the contents of the cup into a suitable container.

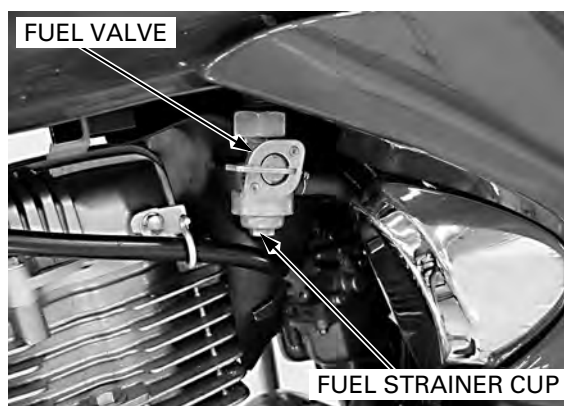

Remove the O-ring and fuel strainer screen.

Wash the fuel strainer screen and cup in clean non-flammable high flash point solvent.

Install the fuel strainer screen, new O-ring and fuel strainer cup to the fuel valve body, making sure that the O-ring is in place.

Tighten the fuel strainer cup securely.

Turn the fuel valve "ON" and be sure there are no fuel leaks.

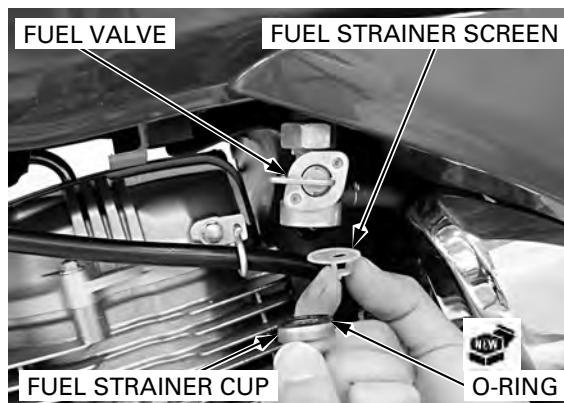

THROTTLE OPERATION

Check the throttle grip for smooth operation.
Check that the throttle opens and automatically closes in all steering positions.

If the throttle grip does not return properly, check the throttle cable routing.

Check for any deterioration or damage to the throttle cable.

If the throttle grip still does not return properly, lubricate or replace the throttle cables.

With the engine idling, turn the handlebar all the way to the right and left to ensure that the idle speed does not change.

If idle speed increase, check the throttle grip free play and the throttle cable connection.

Measure the free play at the throttle grip flange.

FREE PLAY: 2.0 – 6.0 mm (0.08 – 0.24 in)

Slide the dust cover.

Loosen the lock nut and turn the adjuster as required.

After adjustment, tighten the lock nut and reposition the dust cover.

Recheck the throttle operation in all steering positions.

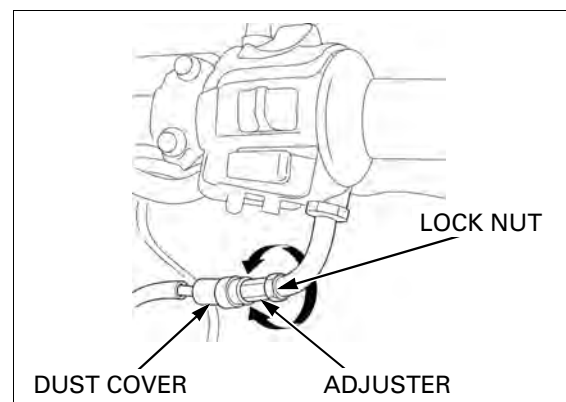
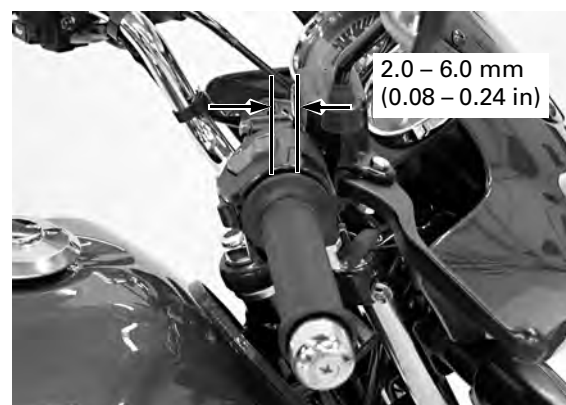

MAINTENANCE

AIR CLEANER

Remove the right side cover (page 2-3).

Disconnect the crankcase breather hose.

Loosen the air cleaner connecting hose band screw. Remove the screws and the air cleaner housing cover.

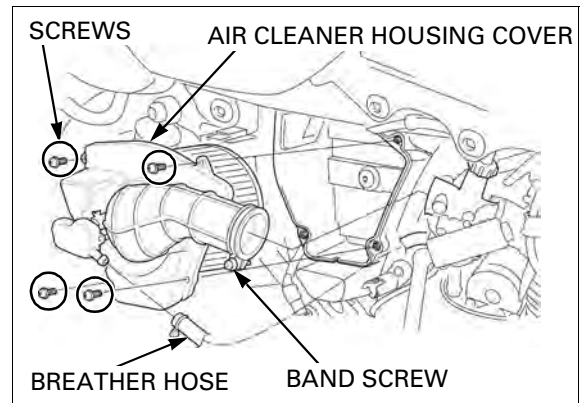

Remove the screw and the air cleaner element.

Replace the element in accordance with the maintenance schedule (page 3-3).

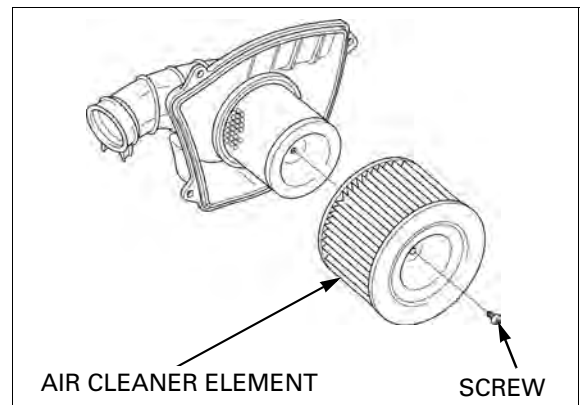

Inspect the element and replace if it is excessively dirty or damaged.

If reusable, clean the element using compressed air from the carburetor side from 30 mm (1.1 in) away.

Blow the element for one minute along the fold line while rotating it.

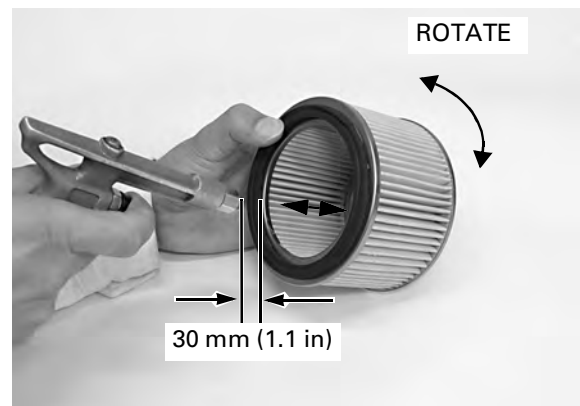

Then, blow the element for 30 seconds from the outside along the fold line while rotating it.

Blow off the remaining dust from the carburetor side from 30 mm (1.1 in) away for 30 seconds along the fold line while rotating it.

Install the removed parts in the reverse order of removal.

TORQUE: AIR CLEANER HOUSING COVER SCREW
1.8 N·m (0.2 kgf·m, 1.3 lbf·ft)

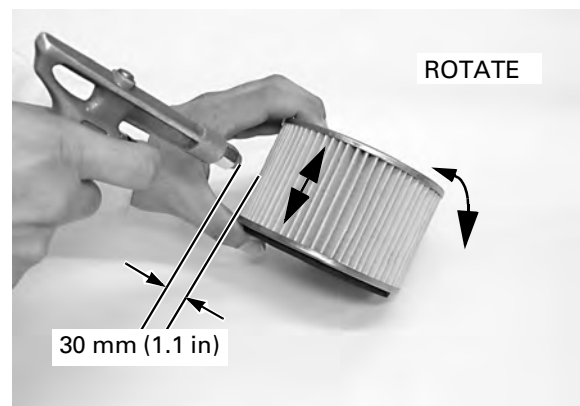

SPARK PLUG

Clean around the spark plug base with compressed air before removing the plug, and be sure that no debris is allowed to enter the combustion chamber.

Disconnect the spark plug cap and remove the spark plug.

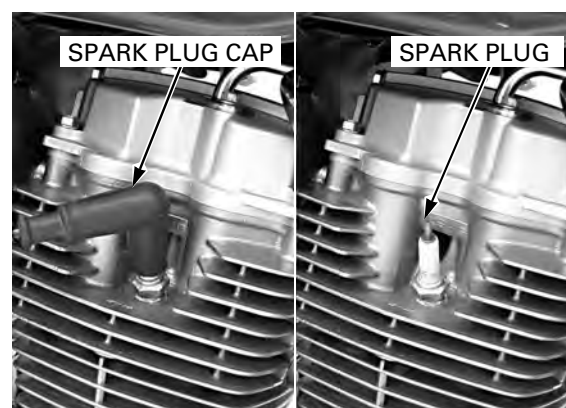

Inspect or replace as described in the maintenance schedule (page 3-3).

Check the following and replace if necessary.

- Insulator for damage
- Electrodes for wear
- Burning condition, coloration;
 - Dark to light brown indicates good condition.
 - Excessive lightness indicates malfunctioning ignition system or lean mixture.
 - Wet or black sooty deposit indicates over-rich mixture.

If the electrode is contaminated with carbon deposits, clean the electrode using a spark plug cleaner.

RECOMMENDED SPARK PLUG:

Standard: DPR8EA-9 (NGK)

For extended high speed riding: DPR9EA-9 (NGK)

Measure the spark plug gap between the center and side electrodes with a feeler gauge of a wire type. If necessary, adjust the gap by bending the side electrode carefully.

SPARK PLUG GAP: 0.80 – 0.90 mm (0.031 – 0.035 in)

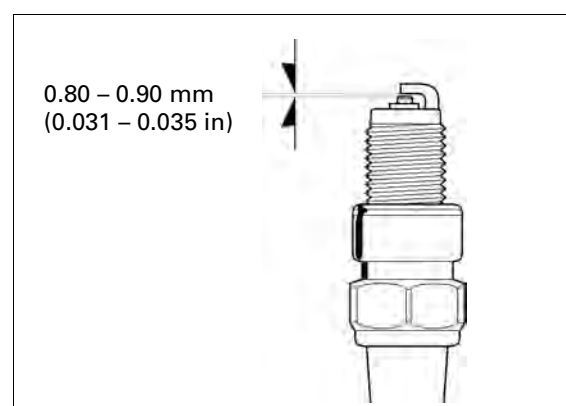
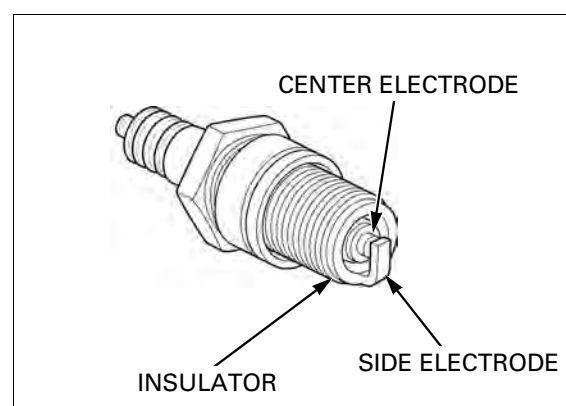

Do not overtighten the spark plug.

Install and hand tighten the spark plug to the cylinder head, then tighten the spark plug to the specified torque.

TORQUE: 18 N·m (1.8 kgf·m, 13 lbf·ft)

Connect the spark plug cap.

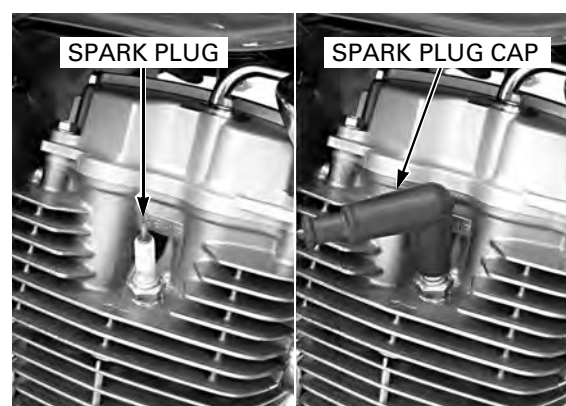

MAINTENANCE

VALVE CLEARANCE

Remove the cylinder head cover (page 7-7).

Inspect and adjust the valve clearance while the engine is cold (below 35°C/95°F).

Remove the crankshaft hole cap and timing hole cap.

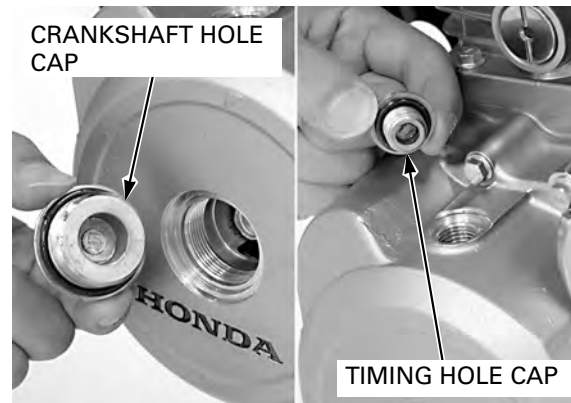

Rotate the crankshaft counterclockwise and align the index line of the "T" mark on the flywheel with the index notch on the left crankcase cover.

Make sure that the piston is at TDC (Top Dead Center) on the compression stroke (The rocker arms should be loose).

If the rocker arms are tight, rotate the crankshaft counterclockwise 360°(1 full turn) and realign the index line of the "T" mark with the index notch.

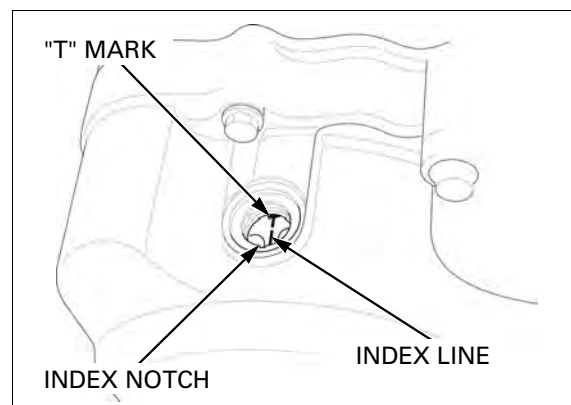

When checking the clearance, slide the feeler gauge from the center toward the outside.

Check the valve clearance by inserting the feeler gauge between the valve adjusting screw and the valve stem.

VALVE CLEARANCE:

IN/EX: 0.08 ± 0.02 mm (0.003 ± 0.001 in)

If the valve clearance is incorrect, loosen the valve adjusting screw lock nut and adjust the valve clearance by turning the adjusting screw until there is a slight drag on the feeler gauge.

TOOLS:

Valve adjusting wrench **07908-KE90000**

Apply clean engine oil to the lock nut.

Hold the adjusting screw and tighten the lock nut to the specified torque.

TORQUE: 14 N·m (1.4 kgf·m, 10 lbf·ft)

Recheck the valve clearance.

Install the cylinder head cover (page 7-8).

Apply clean engine oil to the new O-rings.

Install the O-rings to the crankshaft hole cap and timing hole cap.

Install and tighten the crankshaft hole cap and timing hole cap to the specified torque.

TORQUE:

Timing hole cap: 6 N·m (0.6 kgf·m, 4.4 lbf·ft)

Crankshaft hole cap: 8 N·m (0.8 kgf·m, 5.9 lbf·ft)

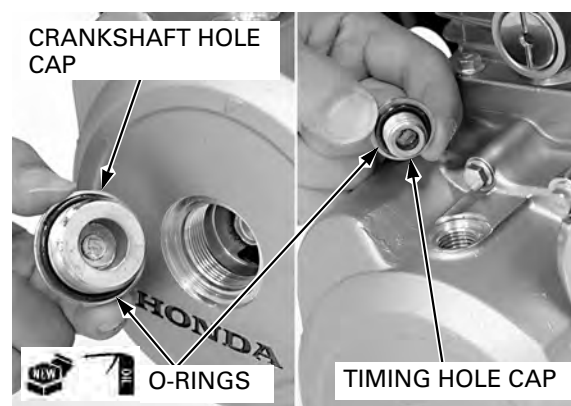
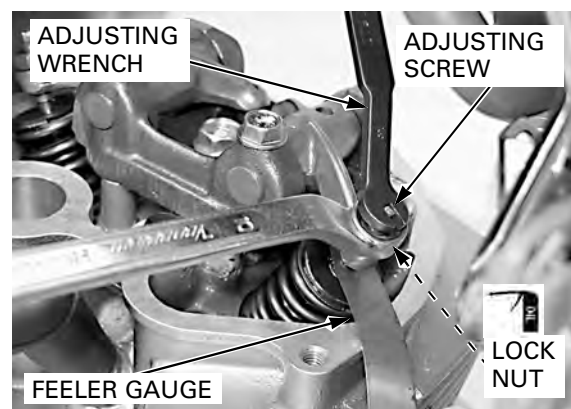

ENGINE OIL

LEVEL CHECK

Clean around the oil filler cap/dipstick and nearby surface.
 Start the engine and let it idle for 3 – 5 minutes.
 Stop the engine and wait 2 – 3 minutes.
 Support the motorcycle upright on a level surface.

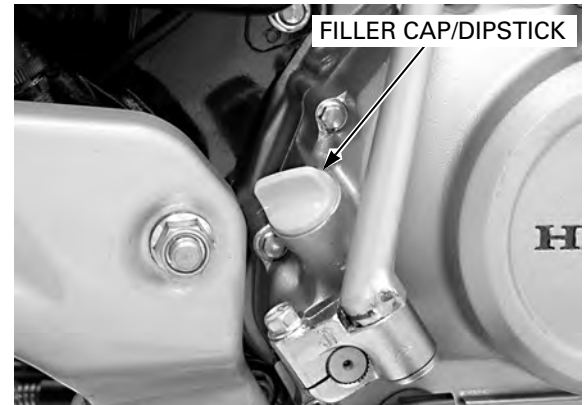

Remove the filler cap/dipstick and wipe the oil with a clean cloth.
 Insert the dipstick without screwing it in, remove it and check the oil level

The level should be between the "UPPER" and "LOWER" level lines of the oil filler cap/dipstick.

If the oil level is below or near the lower level line on the dipstick, add the recommended oil to the upper level line from the oil filler hole.

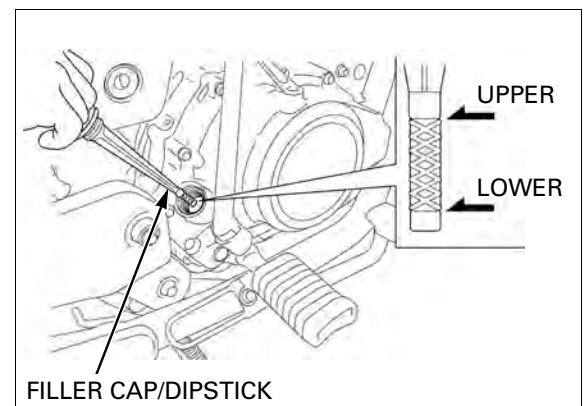

Other viscosities shown in the chart may be used when the average temperature in your riding area is within the indicated range.

RECOMMENDED ENGINE OIL:

Honda 4-stroke oil or equivalent motor oil
API service classification: SF or SG
Viscosity: SAE 10W-30

OIL VISCOSITIES

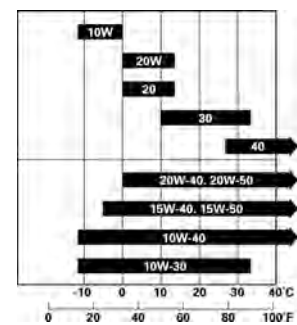

Coat a new O-ring with clean engine oil and install the oil filler cap/dipstick.

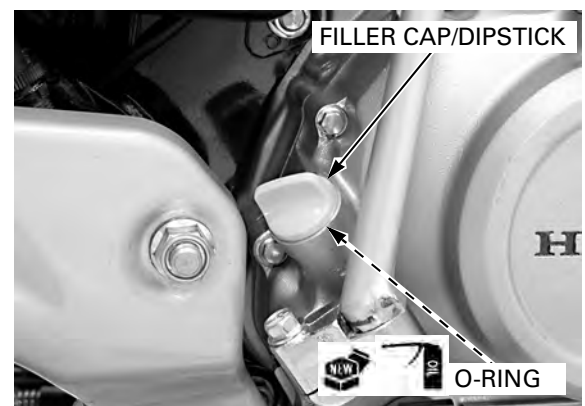

MAINTENANCE

OIL CHANGE

Drain the engine oil while the engine is warm. This ensures complete and rapid draining.

Place the motorcycle on its center stand.
Remove the oil filler cap/dipstick.

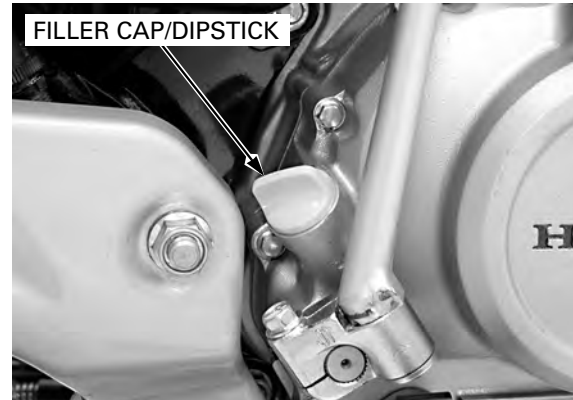

Place an oil pan under the engine to collect the oil, then remove the oil drain bolt and sealing washer.

After draining the oil completely, install the new sealing washer and oil drain bolt.

Tighten the oil drain bolt to the specified torque.

TORQUE: 24 N·m (2.4 kgf·m, 18 lbf·ft)

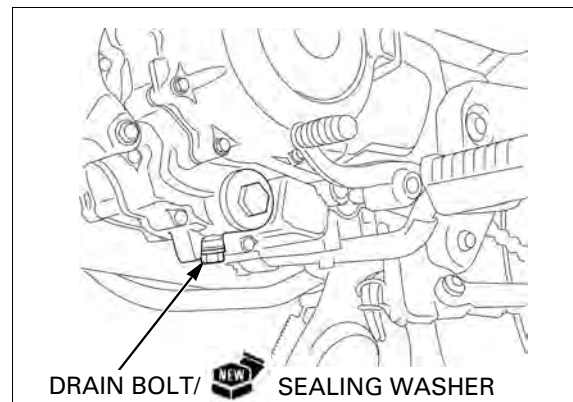

If the maintenance for the engine oil strainer screen is scheduled, perform it before filling the crankcase with engine oil.

Fill the crankcase with the recommended engine oil.

ENGINE OIL CAPACITY:

After draining: 0.8 liter (0.8 US qt, 0.7 Imp qt)

After disassembly: 1.1 liter (1.2 US qt, 1.0 Imp qt)

Install the oil filler cap/dipstick.

Check the oil level (page 3-9).

Make sure that there are no oil leaks.

ENGINE OIL STRAINER SCREEN

OIL CHANGE/STRAINER CLEANING

Drain the engine oil (page 3-10).

Remove the oil strainer screen cap, O-ring, spring and oil strainer screen.

Check the oil strainer screen for clogs or damage.

Install the oil strainer screen and spring into the crankcase as shown.

Coat a new O-ring with clean engine oil.

Apply clean engine oil to the oil strainer screen cap threads and seating surface.

Install and tighten the oil strainer screen cap with a new O-ring.

TORQUE: 15 N·m (1.5 kgf·m, 11 lbf·ft)

Fill the crankcase with recommended engine oil.

Check the engine oil level (page 3-9).

Make sure that there are no oil leaks.

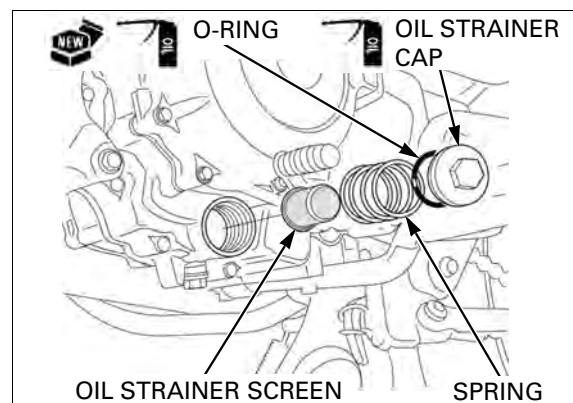

ENGINE IDLE SPEED

- Inspect and adjust the idle speed after all other engine maintenance items have been performed and are within specifications.
- Engine must be warm for accurate adjustment. Ten minutes of stop-and-go riding is sufficient.

Warm the engine, shift the transmission into neutral and support the motorcycle upright on a level surface.

Connect a tachometer and check the idle speed.

IDLE SPEED: 1,400 ± 100 min⁻¹ (rpm)

If the adjustment is necessary, turn the throttle stop screw as required.

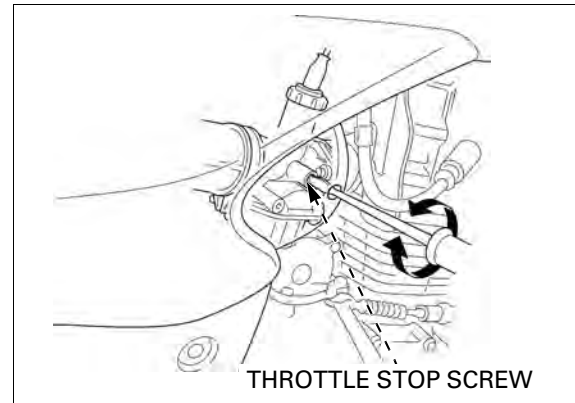

SECONDARY AIR SUPPLY SYSTEM

- The secondary air supply system introduces filtered air into exhaust gases in the exhaust port. The secondary air is drawn into the exhaust port whenever there is negative pressure pulse in the exhaust system. This charged secondary air promotes burning of the unburned exhaust gases and changes a considerable amount of hydrocarbons and carbon monoxide into relatively harmless carbon dioxide and water.

Remove the fuel tank (page 2-4).

Check the air cleaner sub filter for damage and replace if necessary (page 5-22).

Check the hoses for deterioration, damage or loose connections.

If the hoses show any signs of heat damage or/and show carbon deposit, inspect the PAIR check valve (page 5-23).

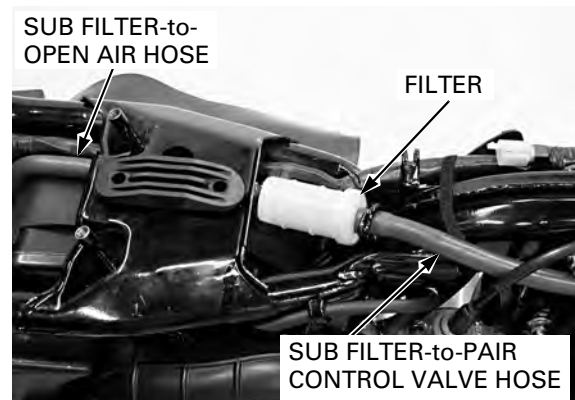

If the hoses show any signs of heat damage, inspect the PAIR check valve for damage ((page 5-23).

Check the following hoses for deterioration, damage, or loose connection.

Make sure that the hoses are not cracked.

- Air cleaner sub filter-to-open air hose.
- Air cleaner sub filter-to-PAIR control valve hose.
- Air supply pipe-to-PAIR control valve hose.

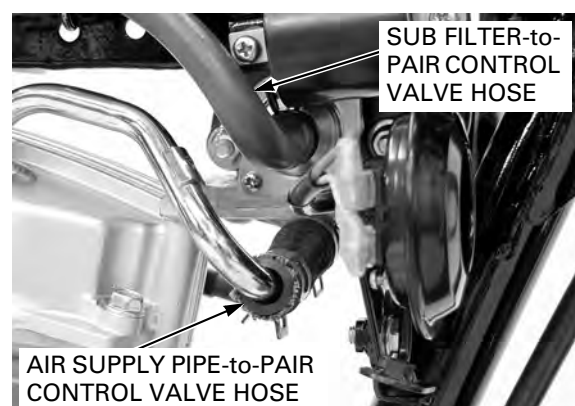

MAINTENANCE

Check the vacuum hose between the PAIR control valve and carburetor insulator for deterioration, damage or loose connections. Make sure that the hose is not kinked, pinched or cracked.

Install the fuel tank (page 2-4).

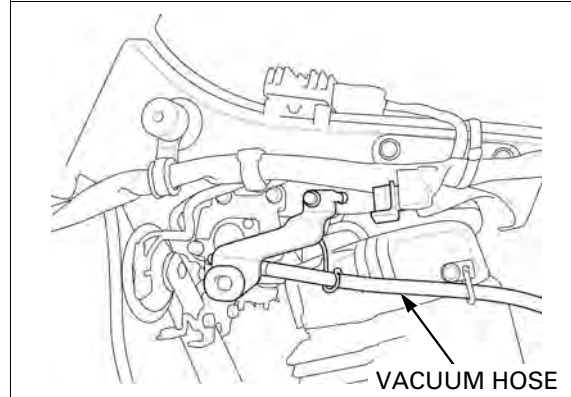

DRIVE CHAIN

DRIVE CHAIN SLACK INSPECTION

NOTICE

Excessive chain slack, 50 mm (2.0 in) or more, may damage the frame.

Never inspect or adjust the drive chain while the engine is running.

Turn off the ignition switch, place the motorcycle on its center stand and shift the transmission into neutral. Check the slack in the drive chain lower run midway between the sprockets.

CHAIN SLACK: 10 – 20 mm (0.4 – 0.8 in)

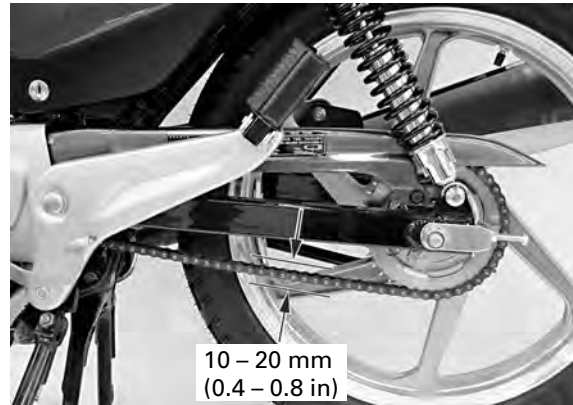

ADJUSTMENT

Loosen the rear axle nut.
Loosen the both lock nuts.
Turn both adjusting bolts until the correct drive chain slack is obtained.
Make sure that the index marks on the both adjusters are aligned with the rear edges of the swingarm.
Tighten the rear axle nut to the specified torque.

TORQUE: 59 N·m (6.0 kgf·m, 44 lbf·ft)

Tighten the both lock nuts.

Recheck the drive chain slack and free wheel rotation.

Check the rear brake pedal free play (page 3-17).

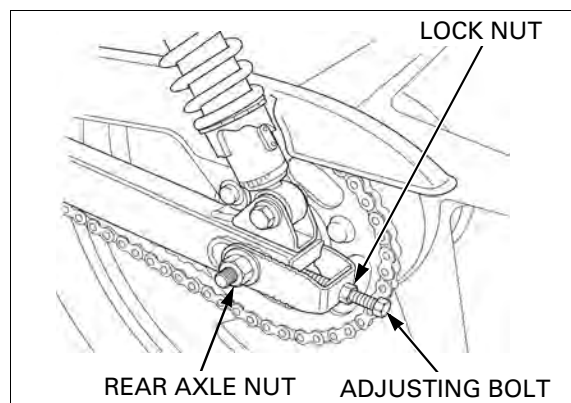

REMOVAL/INSTALLATION

Remove the left crankcase rear cover (page 6-4).
 Carefully remove the retaining clip with pliers.
 Remove the master link, link plate and drive chain.
 Install the drive chain onto the sprockets.
 Install the master link and link plate.
 Install the retaining clip with its open end opposite direction of the chain travel.
 Install the left crankcase rear cover (page 6-5).

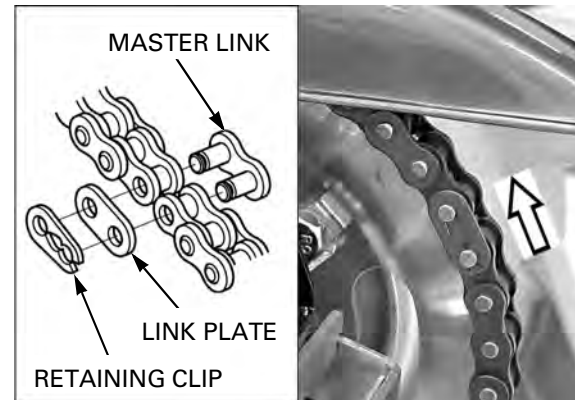

CLEANING AND LUBRICATION

If the drive chain is extremely dirty, it should be removed and cleaned prior to lubrication.
 Remove the drive chain (page 3-13).
 Clean the chain with non-flammable or high flash point solvent and wipe it dry.
 Make sure that the chain is completely dry before lubricating.
 Lubricate the drive chain with # 80 – 90 gear oil or drive chain lubricant. Wipe off the excess oil or chain lubricant.

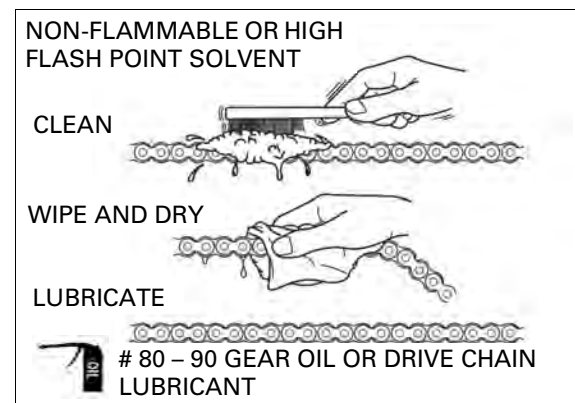

Inspect the drive chain for possible damage or wear.
 Replace any chain that has damaged rollers, loose fitting links, or otherwise appears unserviceable.
 Measure the drive chain length with the chain held so that all the links are straight.

DRIVE CHAIN LENGTH (41pins/40 links)
STANDARD: 508 mm (20.0 in)
SERVICE LIMIT: 518 mm (20.4 in)

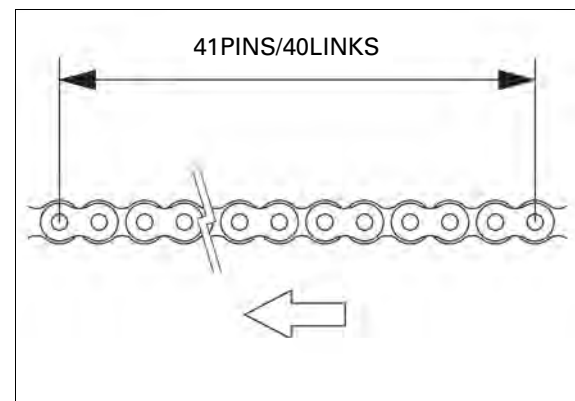

Inspect the drive and driven sprocket teeth for wear or damage, replace if necessary.
 Never use a new drive chain on worn sprockets.
 Both chain and sprockets must be in good condition, or the new replacement chain will wear rapidly.
 Install the drive chain (page 3-13).

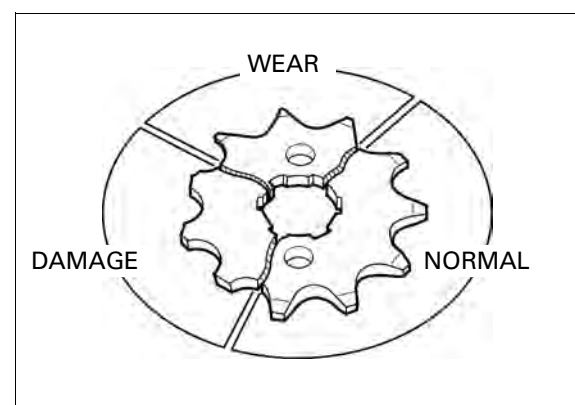

MAINTENANCE

BATTERY

Remove the battery (page 15-6).

Add only distilled water. Tap water will shorten the life of the battery.

Inspect the electrolyte level.

When the electrolyte level nears the lower level, remove the filler caps and add distilled water to the upper level line.

After filling, install each filler cap firmly.

After connecting the battery terminals, lightly coat the terminals with clean grease.

Install the battery (page 15-6).

Make sure that the battery breather hose is correctly positioned, not kinked, trapped or bent in such a way as to obstruct the passage of the air.

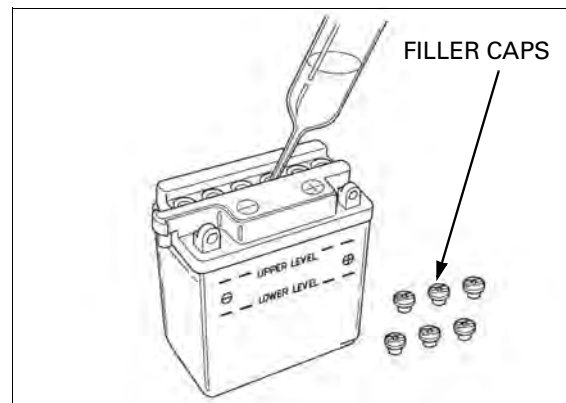

BRAKE FLUID (TYPE II, IV)

- Do not mix different types of fluid, as they are not compatible with each other.
- Do not allow foreign material to enter the system when filling the reservoir.

NOTICE

Spilled fluid can damage painted, plastic or rubber parts. Place a rag over these parts whenever the system is serviced.

Turn the handlebar so the reservoir is level and check the front brake fluid reservoir level through the sight glass.

When the fluid level is low, check the brake pads for wear (page 3-16).

A low fluid level may be due to worn brake pads. If the brake pads are worn, the caliper pistons are pushed out, and this causes a low reservoir level. If the brake pads are not worn and the fluid level is low, check entire system for leaks (page 3-17).

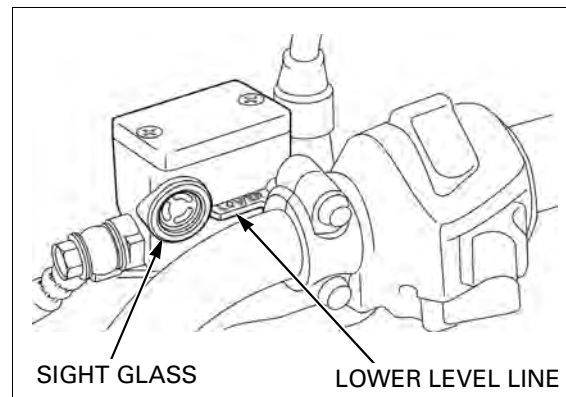

If the level is near the lower level line, remove the reservoir cap, set plate and diaphragm, and fill the reservoir DOT 3 or DOT 4 brake fluid from a sealed container to the casting ledge.

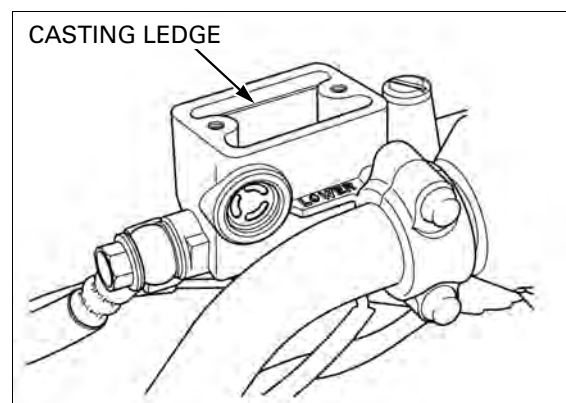

Install the diaphragm, set plate and reservoir cap, and tighten the cap screws to the specified torque.

TORQUE: 1.5 N·m (0.2 kgf·m, 1.1 lbf·ft)

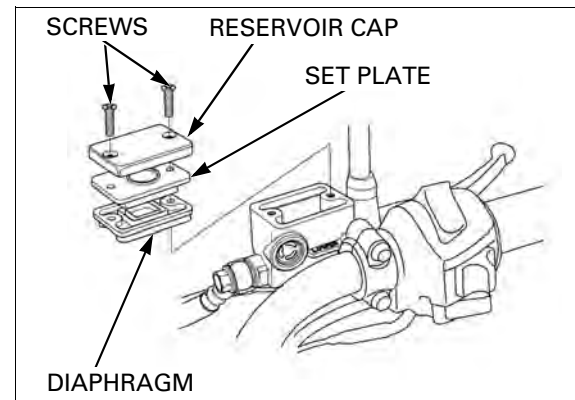

BRAKE SHOES WEAR (TYPE I, III)

FRONT BRAKE SHOES

Check the wear indicator position when the brake lever is applied.

If the arrow on the brake arm aligns with the reference mark "Δ" on the brake panel, inspect the brake drum (page 12-20).

Replace the brake shoes (page 12-20) if the drum I.D. is within the service limit.

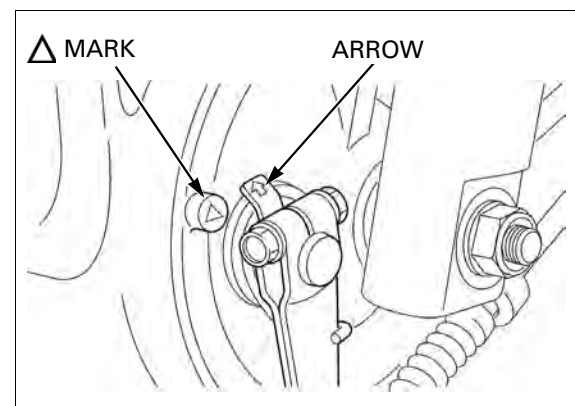

REAR BRAKE SHOES

Check the wear indicator position when the brake pedal is applied.

If the arrow on the brake arm aligns with the reference mark "Δ" on the brake panel, inspect the brake drum (page 13-13).

Replace the brake shoes (page 13-13) if the drum I.D. is within the service limit.

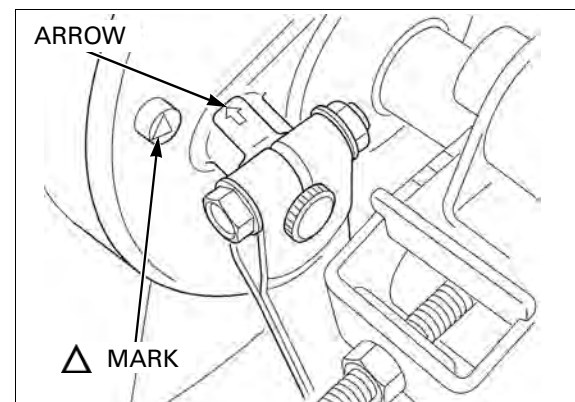

MAINTENANCE

BRAKE SHOES/PADS WEAR (TYPE II, IV)

FRONT BRAKE PADS

Check the brake pads for wear.

Replace the brake pads if either pad is worn to the wear limit groove.

Refer to page 14-7 for brake pad replacement.

REAR BRAKE SHOES

The service procedure is in the same method with the type I and III (page 3-15).

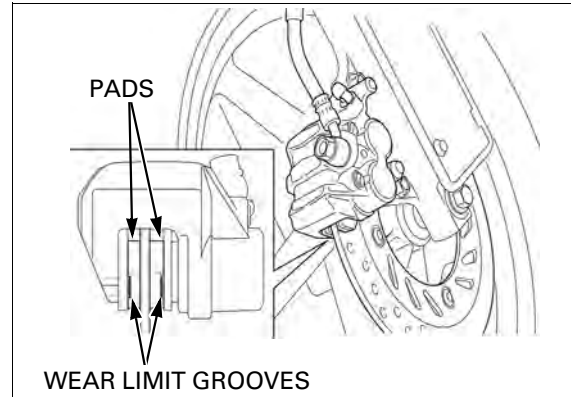

BRAKE SYSTEM

FRONT BRAKE

TYPE I, III

Check the brake cable and brake lever for loose connections, excessive play, or other damage. Replace or repair if necessary.

Inspect the brake cable for kinks or damage, and lubricate the cable.

Measure the front brake lever free play at the tip of the brake lever.

FREE PLAY: 10 – 20 mm (0.4 – 0.8 in)

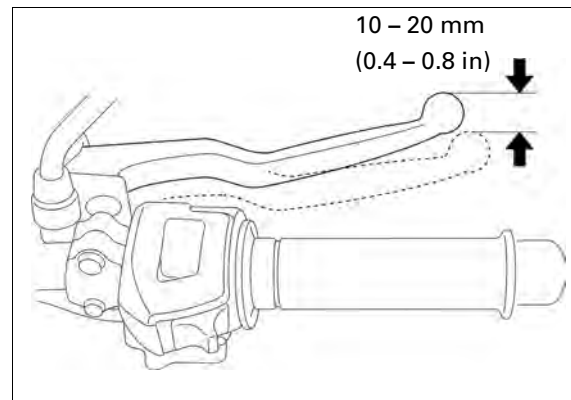

Minor adjustments are made with the upper adjuster.

Slide the dust cover.

Loosen the lock nut and turn the adjuster to obtain correct free play.

Tighten the lock nut and reposition the dust cover.

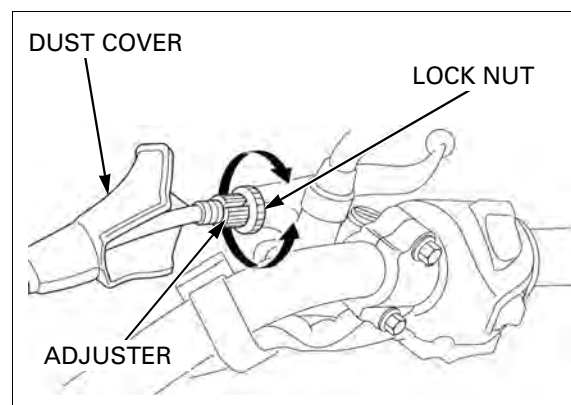

Make sure the cut-out of the adjusting nut is seated on the brake arm pin.

Major adjustments are made with the lower adjuster.

Turn the adjusting nut to obtain correct free play.

Recheck the brake lever free play (page 3-16).

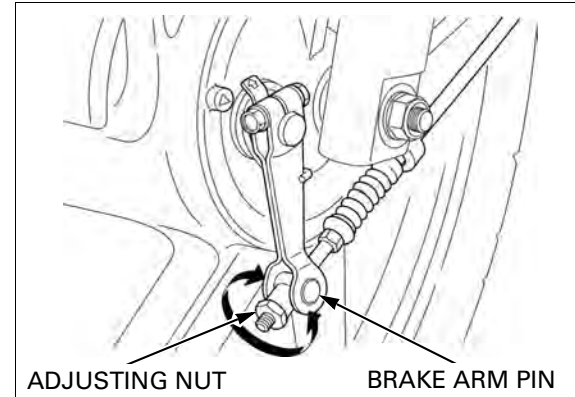

TYPE II, IV

Inspect the brake hose and fittings for deterioration, cracks and signs of leakage.

Tighten any loose fittings.

Replace hoses and fittings as required.

Firmly apply the brake lever, and check that no air has entered the system.

If the lever feels soft or spongy when operated, bleed the air from the system.

Refer to page 14-5 for brake bleeding procedures.

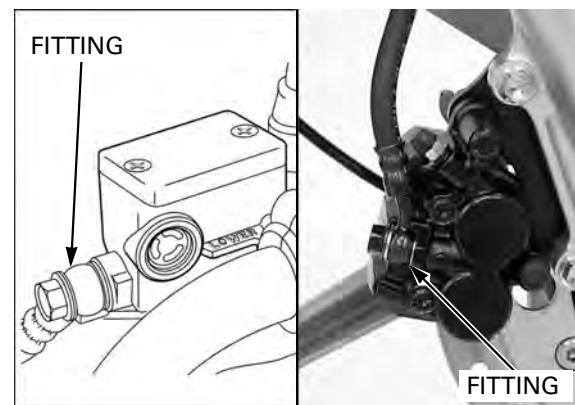

REAR BRAKE

Check the brake pedal and brake rod for loose connections, excessive play, or other damage. Replace or repair if necessary.

Measure the rear brake pedal free play.

FREE PLAY: 20 – 30 mm (0.8 – 1.2 in)

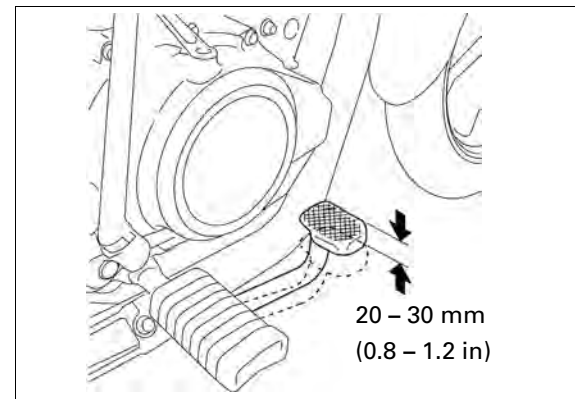

Make sure the cut-out of the adjusting nut is seated on the brake arm pin.

Adjust the rear brake pedal free play by turning the adjusting nut.

Recheck the free play, then check and adjust the brake light switch (page 3-18).

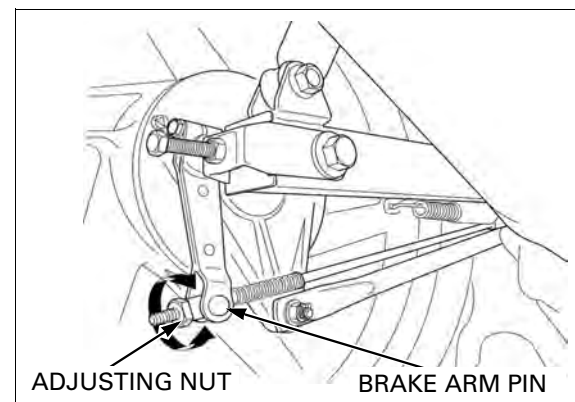

MAINTENANCE

BRAKE LIGHT SWITCH

The front brake light switch does not require adjustment.

Adjust the rear brake light switch so that the brake light comes on just prior to the brake actually being engaged.

If the light fails to come on properly, adjust the brake light switch by holding the switch body and turning the adjuster.

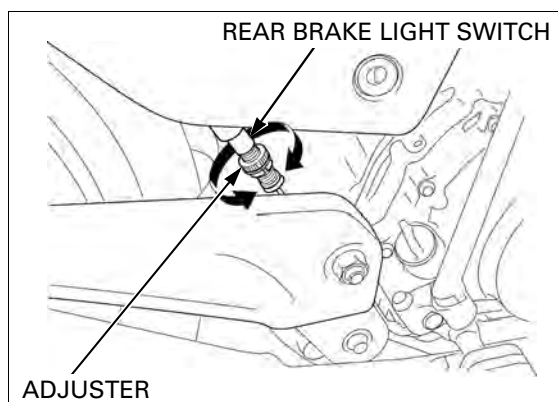

HEADLIGHT AIM

Adjust the headlight beam as specified by local laws and regulations.

Place the motorcycle on a level surface.

Adjust the headlight beam vertically by loosening the adjusting bolt and moving the headlight unit.

Tighten the adjusting bolt after adjustment.

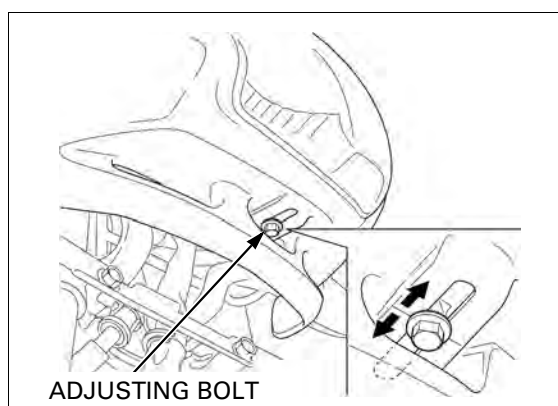

CLUTCH SYSTEM

Inspect the clutch cable for kinks or damage, and lubricate the cable if necessary.

Measure the clutch lever free play at the tip of the clutch lever.

FREE PLAY: 10 – 20 mm (0.4 – 0.8 in)

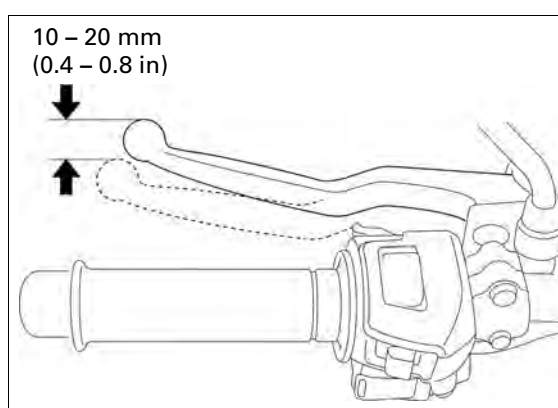

Minor adjustments are made with the upper adjuster at the clutch lever.

Slide the dust cover, loosen the lock nut and turn the adjuster to obtain the correct free play.

Tighten the lock nut and reposition the dust cover.

NOTICE

The adjuster may be damaged if it is positioned too far out, leaving minimal thread engagement.

If the adjuster is threaded out near the limit and the correct free play cannot be obtained, turn the adjuster all the way in and back out one turn.

Tighten the lock nut and make major adjustments as follows.

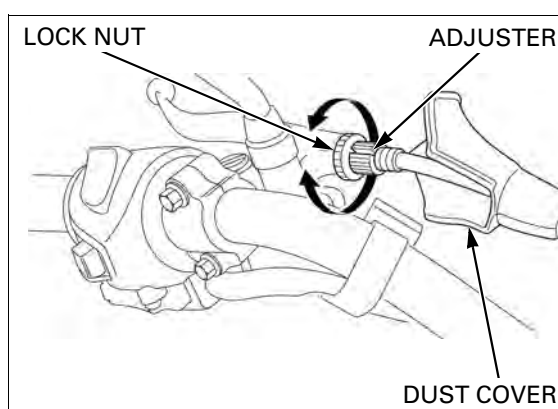

Major adjustments are made with the lower adjusting nut at the engine.

Loosen the lock nut and turn the adjusting nut. After adjustment is complete, tighten the lock nut while holding the adjusting nut.

Check the clutch operation.

If the correct free play cannot be obtained, or the clutch slips during the test ride, disassemble and inspect the clutch (page 9-7).

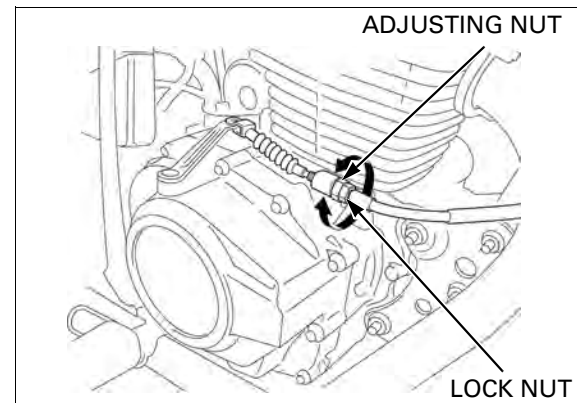

SIDE STAND

Check the side stand spring for damage or loss of tension.

Check the side stand operation for freedom of movement and lubricate the side stand pivot if necessary.

Check that the side stand pivot bolt and lock nut are tightened.

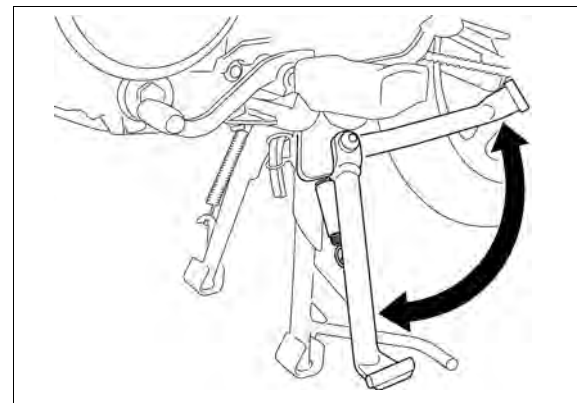

SUSPENSION

FRONT

Check the action of the forks by applying the front brake and compressing front suspension several times.

Check the entire assembly for signs of leaks, damage or loose fasteners.

Replace damaged components which cannot be repaired.

Tighten all nuts and bolts.

Refer to page 12-24 for fork service.



REAR

Check the action of the shock absorber by compressing it several times.

Check the entire shock absorber assembly for signs of leaks, damage or loose fasteners.

Replace damaged components which cannot be repaired.

Tighten all nuts and bolts.

Refer to page 13-20 for shock absorber service.



MAINTENANCE

Raise the rear wheel off the ground and support the motorcycle securely.

Check for worn swingarm by grabbing the swingarm and attempting to move the wheel side to side.



NUTS, BOLTS, FASTENERS

Check that all chassis nuts and bolts are tightened to their correct torque values (page 1-10).

Check that all cotter pins, safety clips, hose clamps and cable stays are in place and properly secured.

WHEELS/TIRES

Check for worn front wheel bearings by grabbing the front wheel and attempting to move the wheel side to side.

Replace the front wheel bearings if any looseness is noted (Type I, III: page 12-13 or Type II, IV: page 12-16).

Making sure that the fork is not allowed to move, raise the front wheel and check for play.

Turn the wheel and check that it rotates smoothly with no unusual noises.

If any abnormal conditions are suspected, inspect the front wheel bearings (Type I, III: page 12-12 or Type II, IV: page 12-15).



Support the motorcycle securely and raise the rear wheel off the ground.

As the swingarm pivot is included in this check, be sure to confirm the location of the play; i.e. from the wheel bearings or the swingarm pivot.

Check for worn rear wheel bearings by grabbing the rear wheel and attempting to move the wheel side to side.

Check for play in either the wheel or the swingarm pivot.

Turn the wheel and check that it rotates smoothly with no unusual noises.

If any abnormal conditions are suspected, check the rear wheel bearings (page 13-7).



Check the tire pressure when the tires are cold.

RECOMMENDED TIRE PRESSURE AND TIRE SIZE:

		FRONT	REAR
Tire pressure kPa (kgf/cm ² , psi)	Driver only	200 (2.00, 29)	225 (2.25, 33)
	Driver and passenger	200 (2.00, 29)	225 (2.25, 33)
Tire size		80/100-18 M/C (47P)	90/90-18 M/C (51P)

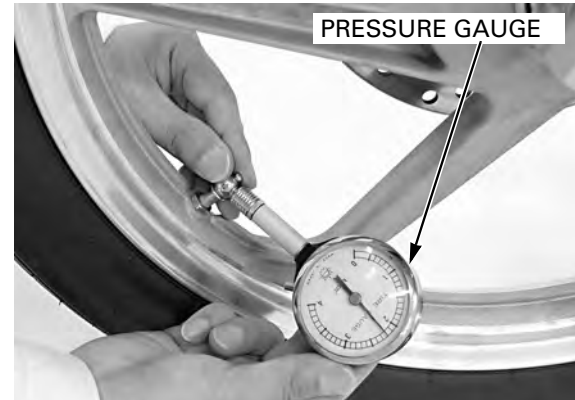

Check the tires for cuts, embedded nails, or other damage.

Check the front wheel (Type I, III: page 12-12 or Type II, IV: page 12-15) and rear wheel (page 13-7) for trueness.

Replace the tires when the wear indicator appears on the tire.

MINIMUM TIRE TREAD DEPTH:

FRONT: To wear indicator

REAR: To wear indicator



STEERING HEAD BEARINGS

Raise the front wheel off the ground by placing a work stand or box under the engine.

Check that the handlebar moves freely from side to side. Make sure the control cables do not interfere with the handlebar rotation.

If the handlebar moves unevenly, binds, or has vertical movement, inspect the steering head bearings (page 12-31).



MEMO

4. LUBRICATION SYSTEM

LUBRICATION SYSTEM DIAGRAM	4-2	OIL FILTER ROTOR CLEANING	4-4
SERVICE INFORMATION	4-3	OIL PUMP.....	4-5
TROUBLESHOOTING	4-3		

LUBRICATION SYSTEM

LUBRICATION SYSTEM DIAGRAM

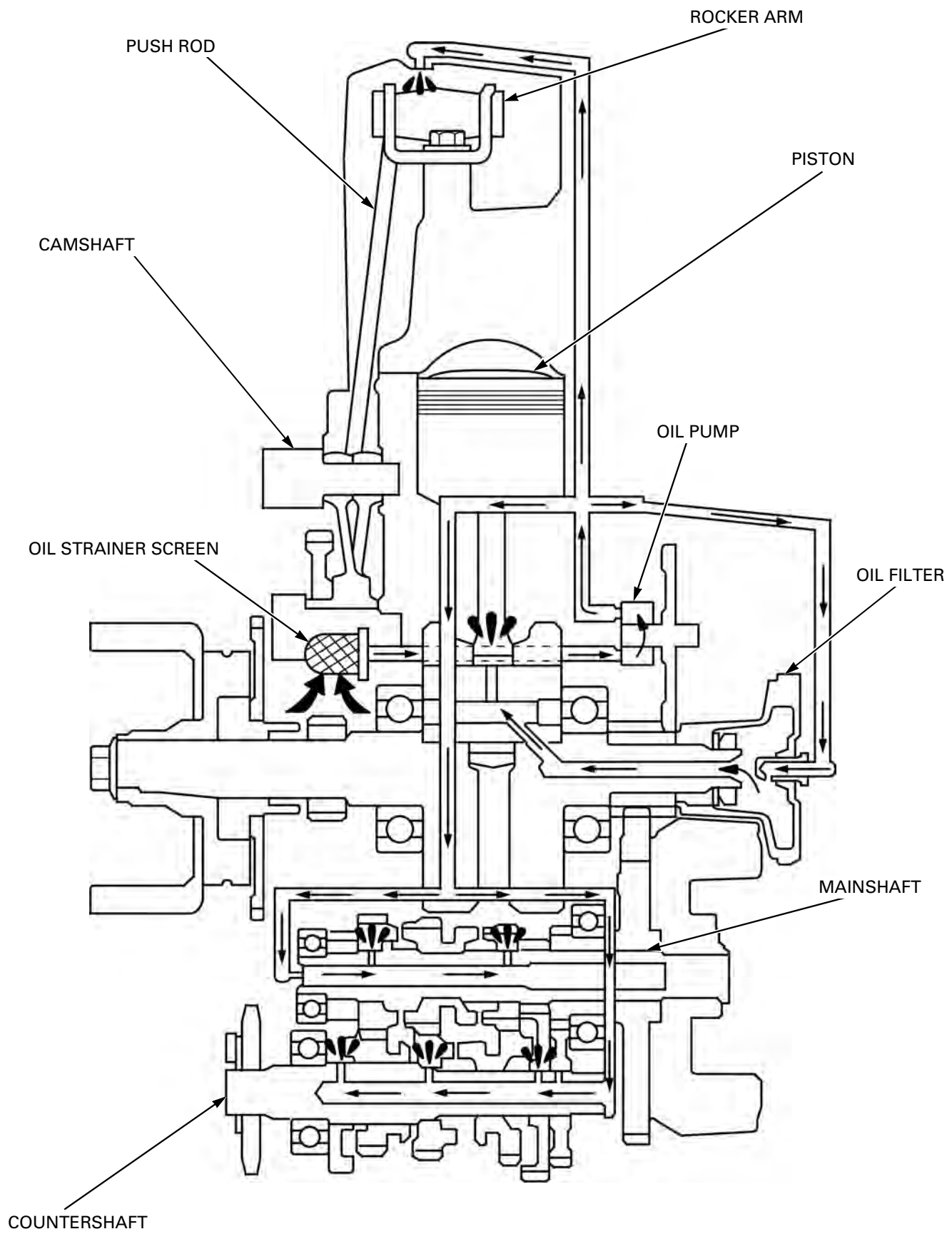

SERVICE INFORMATION

GENERAL

⚠ CAUTION

Used engine oil may cause skin cancer if repeatedly left in contact with the skin for prolonged periods. Although this is unlikely unless you handle used oil on a daily basis, it is still advisable to thoroughly wash your hands with soap and water as soon as possible after handling used oil.

- The oil filter rotor and oil pump can be serviced with the engine installed in the frame.
- The service procedures in this section must be performed with the engine oil drained.
- When removing and installing the oil pump, use care not to allow dust or dirt to enter the engine.
- If any portion of the oil pump is worn beyond the specified service limits, replace the oil pump as an assembly.
- After the oil pump has been installed, check that there are no oil leaks.

SPECIFICATIONS

ITEM		STANDARD	SERVICE LIMIT
Engine oil capacity	After draining	0.8 liter (0.8 US qt, 0.7 Imp qt)	–
	After disassembly	1.1 liter (1.2 US qt, 1.0 Imp qt)	–
Recommended engine oil		Honda 4-stroke oil or equivalent motor oil API service classification: SF or SG Viscosity: SAE 10W-30	–
Oil pump rotor	Tip clearance	0.15 (0.006)	0.20 (0.008)
	Body clearance	0.15 – 0.21 (0.006 – 0.008)	0.40 (0.016)
	Side clearance	0.09 – 0.16 (0.004 – 0.006)	0.25 (0.010)

Unit: mm (in)

TORQUE VALUE

Oil filter rotor cover screw	5 N·m (0.5 kgf·m, 3.7 lbf·ft)
Oil pump mounting screw	10 N·m (1.0 kgf·m, 7 lbf·ft)
Oil pump rotor cover screw	3 N·m (0.3 kgf·m, 2.2 lbf·ft)
Oil pump gear cover bolt	4 N·m (0.4 kgf·m, 3.0 lbf·ft)

TROUBLESHOOTING

Engine oil level too low, high oil consumption

- External oil leaks
- Worn valve guide or seal
- Worn piston rings or incorrect piston ring installation
- Worn cylinder

Engine oil contamination

- Oil not changed often enough
- Faulty cylinder head gasket
- Worn piston rings

LUBRICATION SYSTEM

OIL FILTER ROTOR CLEANING

Remove the right crankcase cover (page 9-5).

Remove the three screws, oil filter rotor cover and gasket.

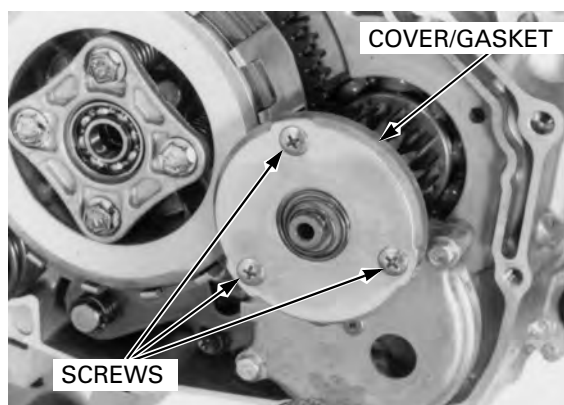

Do not use compressed air. Clean the oil filter rotor cover and inside of the oil filter rotor using a clean lint-free cloth.

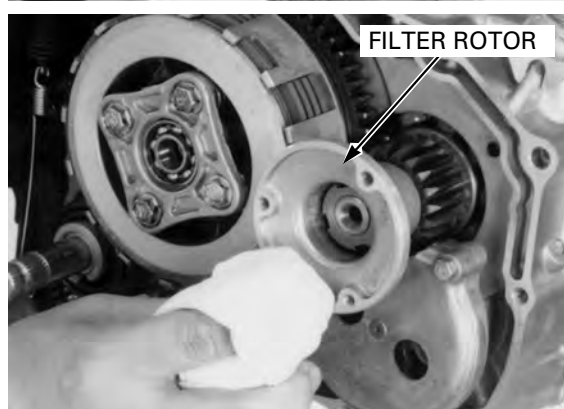

Apply clean engine oil to the oil filter rotor inner surface.

Install a new gasket to the oil filter rotor cover.

Install the oil filter rotor cover to the oil filter rotor.

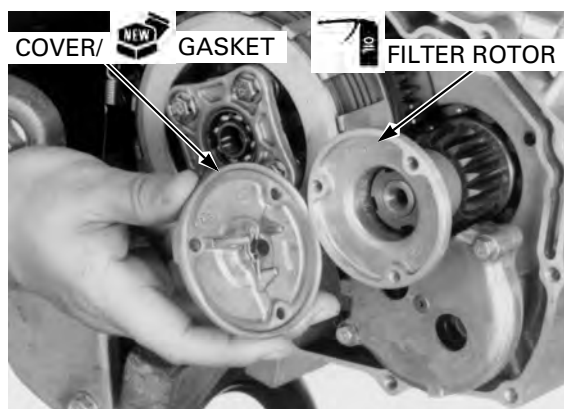

Install and tighten three screws to the specified torque.

TORQUE: 5 N·m (0.5 kgf·m, 3.7 lbf·ft)

Install the right crankcase cover (page 9-14).

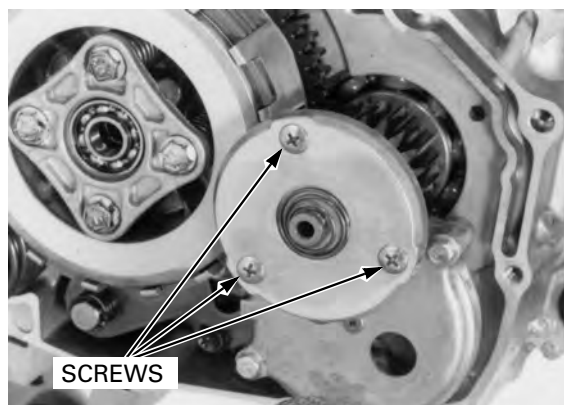

OIL PUMP

REMOVAL

Drain the engine oil (page 3-10).

Remove the right crankcase cover (page 9-5).

Turn the crankshaft clockwise and align the holes in the oil pump drive gear with oil pump mounting screws.

Remove the two mounting screws and oil pump.

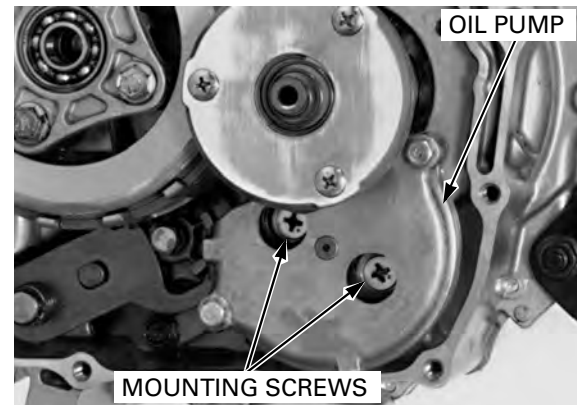

Remove the O-rings from the crankcase grooves.

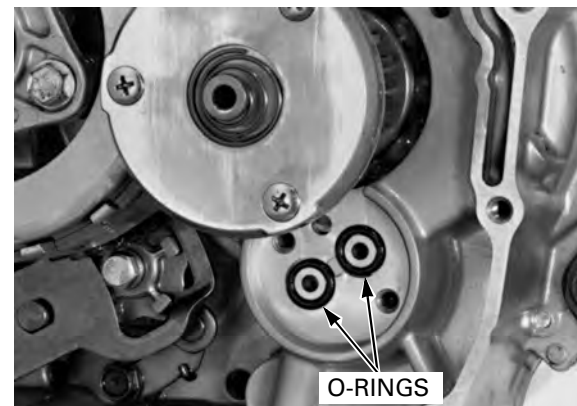

INSPECTION

- Measure at several places and use the largest reading to compare to the service limit.
- If any portion of the oil pump is worn beyond the specified service limits, replace the oil pump and oil pump cover as an assembly.

Remove the rotor cover (page 4-6).

Measure the tip clearance between the inner and outer rotors.

SERVICE LIMIT: 0.20 mm (0.008 in)



LUBRICATION SYSTEM

Measure the body clearance between the outer rotor and pump body.

SERVICE LIMIT: 0.40 mm (0.016 in)



Measure the side clearance using a straight edge and feeler gauge.

SERVICE LIMIT: 0.25 mm (0.010 in)

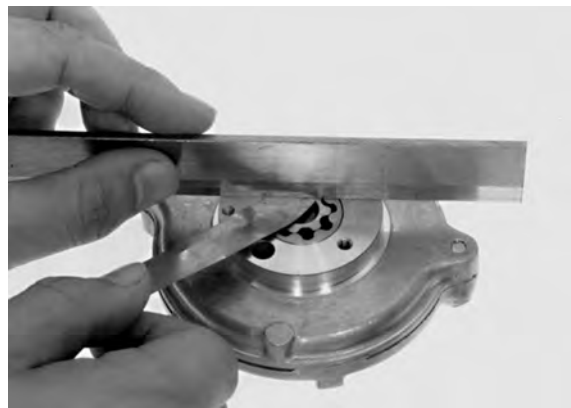

DISASSEMBLY

If any portion of the oil pump is worn beyond the service limit, replace the oil pump as an assembly.

Remove the two screws and rotor cover.

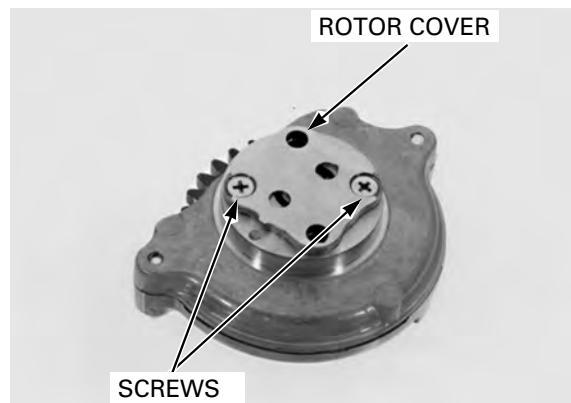

Remove the following:
– Inner and outer rotors

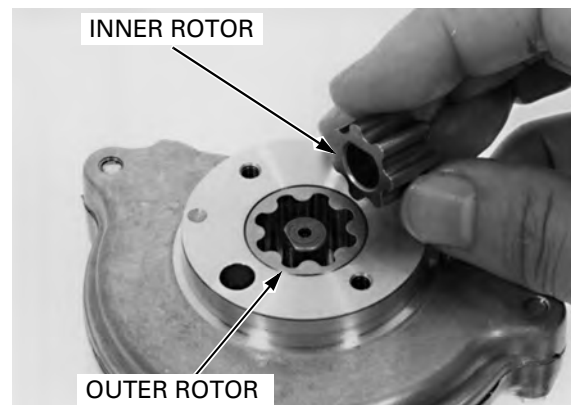

LUBRICATION SYSTEM

- Two bolts
- Gear cover

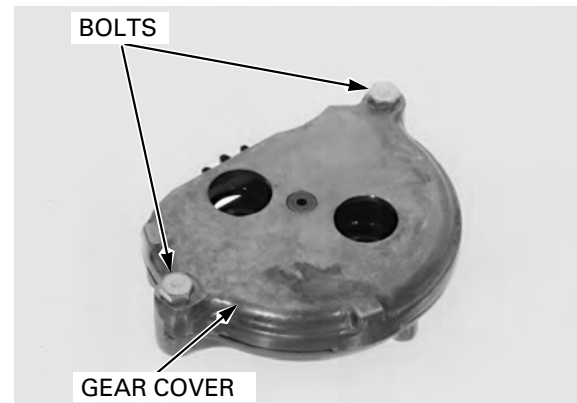

- Rotor shaft
- Pump gear

Check the pump gear and rotor shaft for wear or damage.

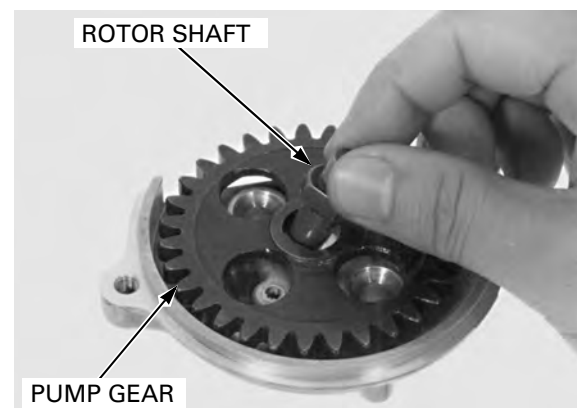

ASSEMBLY

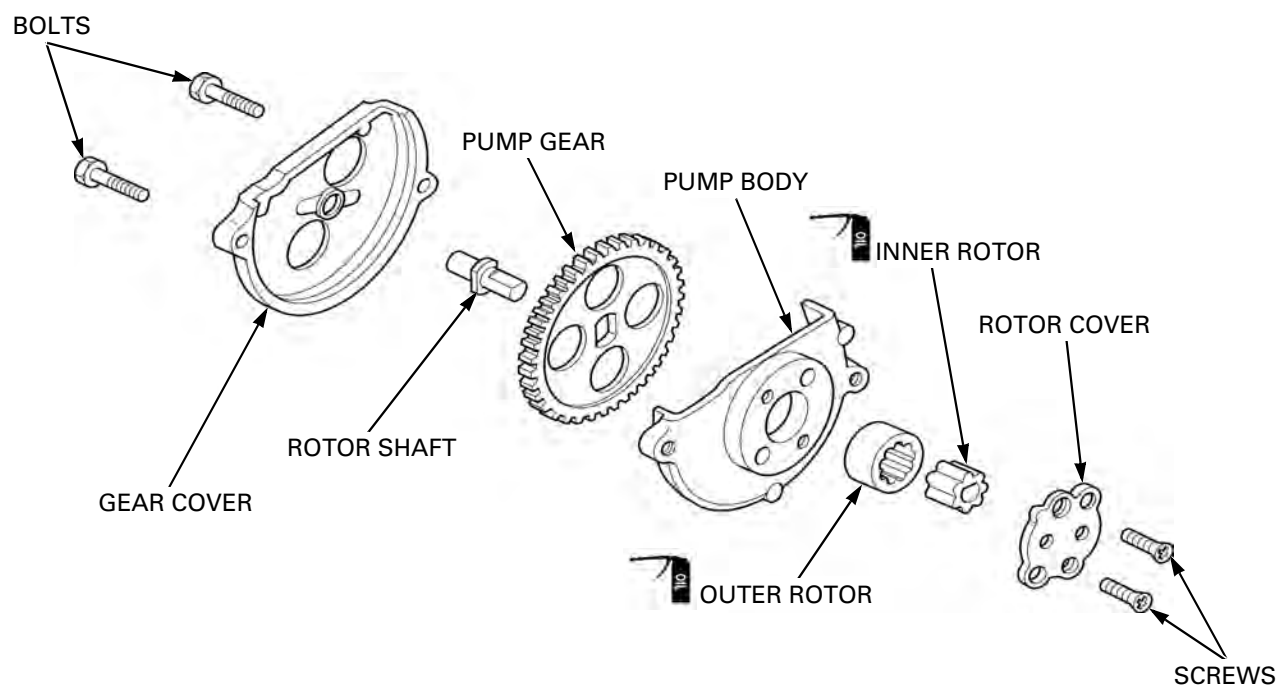

LUBRICATION SYSTEM

Install the pump gear and rotor shaft in the pump body by aligning the flat surfaces of the gear and shaft.

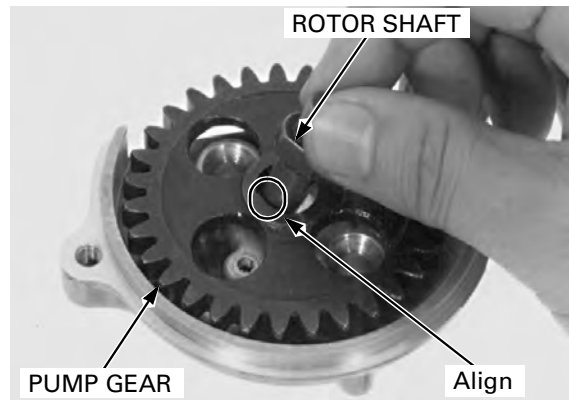

Install the gear cover and tighten the bolts to the specified torque.

TORQUE: 4 N·m (0.4 kgf·m, 3.0 lbf·ft)

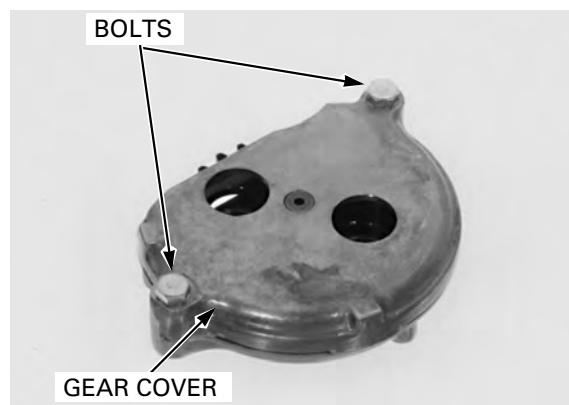

Apply oil to the inner and outer rotors and install them into the oil pump body.

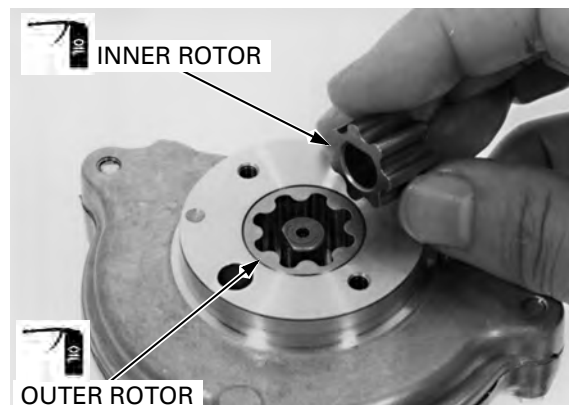

Fill the oil pump with engine oil. Install the rotor cover by aligning its boss with the cavity of the pump body. Install the rotor cover screws and tighten them.

TORQUE: 3 N·m (0.3 kgf·m, 2.2 lbf·ft)

Check that the oil pump rotates smoothly.

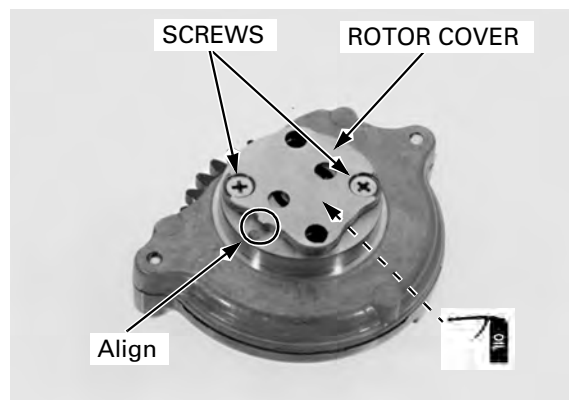

INSTALLATION

Coat new O-rings with oil and install them into the crankcase grooves.

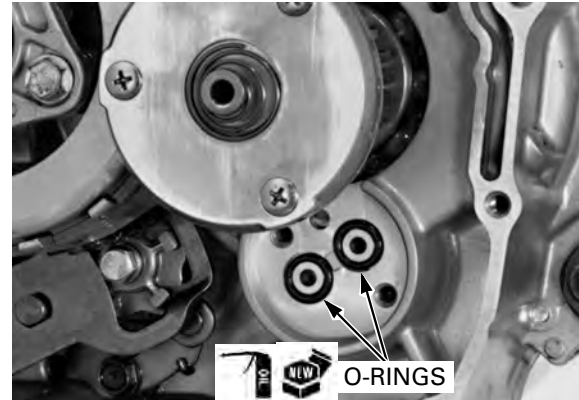

Align the holes of the oil pump drive gear with oil pump mounting screw holes. Install the oil pump onto the crankcase and tighten the mounting screws.

TORQUE: 10 N·m (1.0 kgf·m, 7 lbf·ft)

Install the right crankcase cover (page 9-14).

After installation, fill the crankcase with recommended oil (page 3-10).

Check that there are no oil leaks.

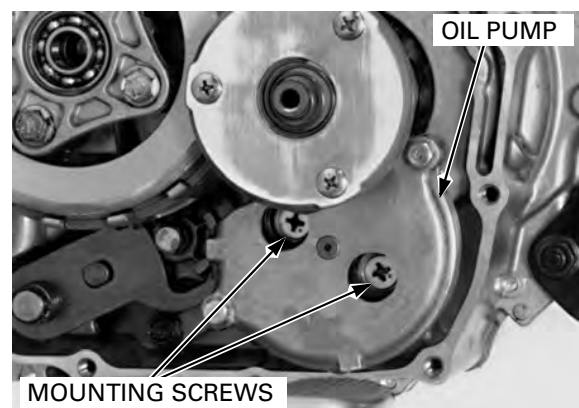

MEMO

5. FUEL SYSTEM

SYSTEM COMPONENTS	5-2	CARBURETOR DISASSEMBLY.....	5-14
SERVICE INFORMATION	5-3	CARBURETOR BODY CLEANING.....	5-15
TROUBLESHOOTING	5-4	CARBURETOR ASSEMBLY.....	5-16
AIR CLEANER HOUSING	5-5	CARBURETOR INSTALLATION.....	5-19
STORAGE TANK.....	5-8	INSULATOR.....	5-20
THROTTLE VALVE.....	5-8	PILOT SCREW ADJUSTMENT.....	5-21
CARBURETOR REMOVAL.....	5-10	SECONDARY AIR SUPPLY SYSTEM	5-22
CHOKE LEVER	5-11	FUEL STRAINER.....	5-26
AIR CUT-OFF VALVE.....	5-13		

FUEL SYSTEM
SYSTEM COMPONENTS

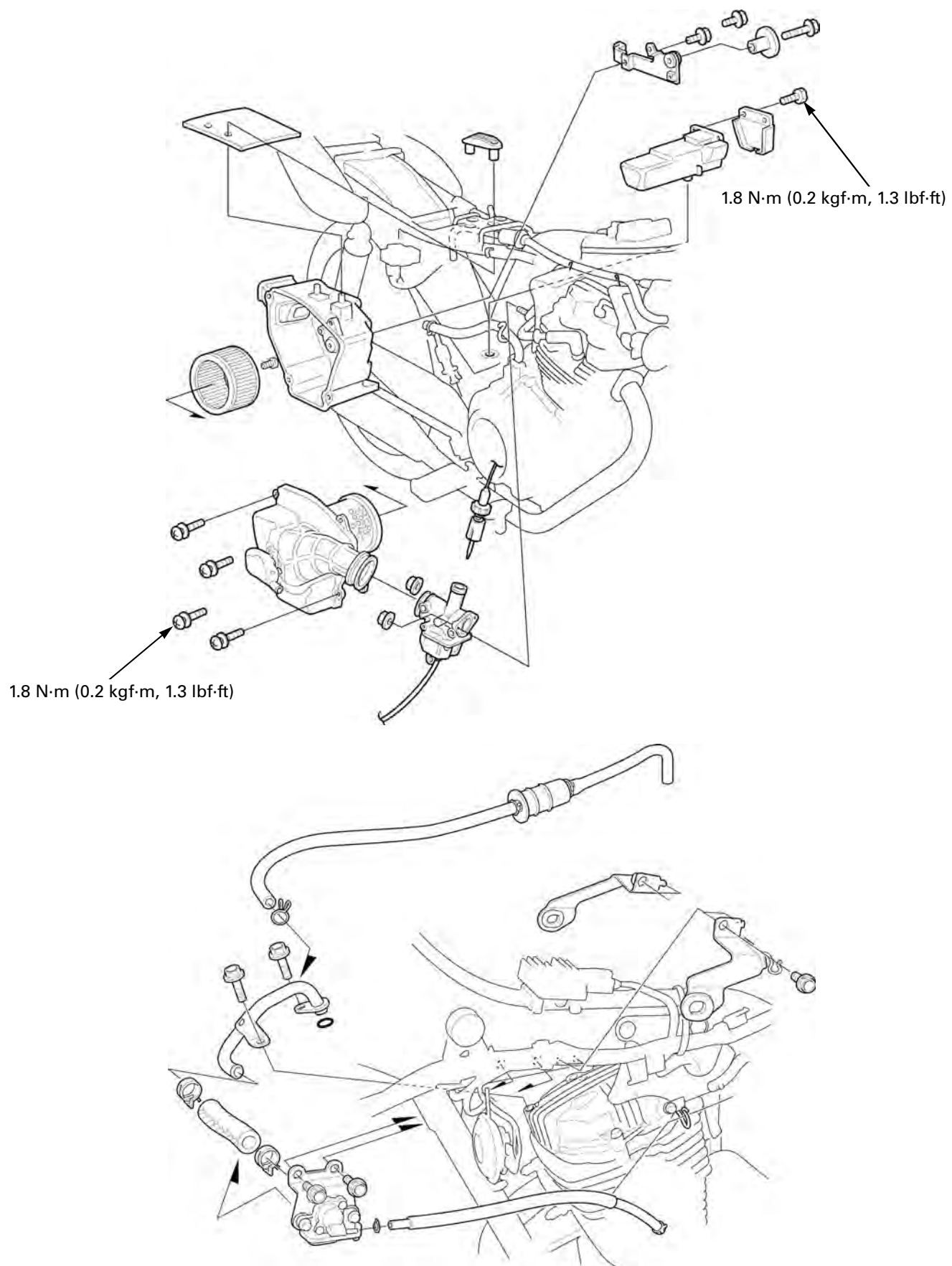

SERVICE INFORMATION

GENERAL

- Work in a well ventilated area. Smoking or allowing flames or sparks in the work area or where gasoline is stored can cause a fire or explosion.
- Bending or twisting the control cable will impair smooth operation and could cause the cable to stick or bind, resulting in loss of vehicle control.
- Before removing the carburetor, place an approved gasoline container under the carburetor drain hose, loosen the drain screw and drain the carburetor.
- After removing the carburetor, cover the intake port of the cylinder head with a shop towel or pieces of tape to prevent any foreign material from dropping into the engine.
- When disassembling the fuel system parts, note the locations of the O-rings. Replace them with new ones on reassembly.
- If the vehicle is to be stored for more than one month, drain the float chamber. Fuel left in the float chamber may cause clogged jets, resulting in hard starting or poor driveability.

SPECIFICATIONS

ITEM	SPECIFICATIONS
Carburetor identification number	PDCBE
Main jet	#95
Slow jet	#38
Pilot screw initial/final opening	See page 5-21
Idle speed	1,400 ± 100 min ⁻¹ (rpm)
Throttle grip free play	2.0 – 6.0 mm (0.08 – 0.24 in)
PAIR control valve specified vacuum	60 kpa (450 mm Hg)
Float level	14.0 mm (0.55 in)

TORQUE VALUES

Choke lever screw	2.1 N·m (0.2 kgf·m, 1.5 lbf·ft)
Carburetor drain screw	1.5 N·m (0.2 kgf·m, 1.1 lbf·ft)
Slow jet	1.8 N·m (0.2 kgf·m, 1.3 lbf·ft)
Needle jet holder	2.5 N·m (0.3 kgf·m, 1.8 lbf·ft)
Main jet	2.1 N·m (0.2 kgf·m, 1.5 lbf·ft)
Float chamber screw	2.1 N·m (0.2 kgf·m, 1.5 lbf·ft)
Air cut-off valve cover screw	2.1 N·m (0.2 kgf·m, 1.5 lbf·ft)
PAIR control valve mounting nut	9 N·m (0.9 kgf·m, 6.6 lbf·ft)
Air cleaner housing cover screw	1.8 N·m (0.2 kgf·m, 1.3 lbf·ft)
Tool box lid screw	1.8 N·m (0.2 kgf·m, 1.3 lbf·ft)

TOOL

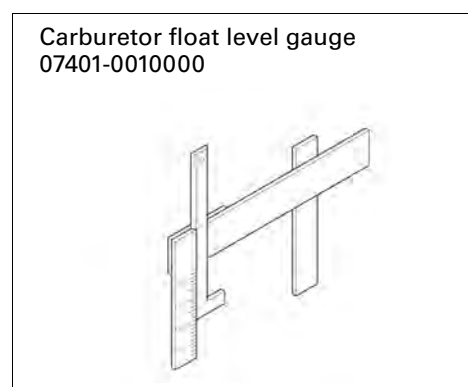

FUEL SYSTEM

TROUBLESHOOTING

Engine won't start

- No fuel in tank
- No spark at plug
- Too much fuel getting to the engine
 - Air cleaner clogged
 - Flooded carburetor
- Intake air leak
- Fuel contaminated/deteriorated
- No fuel to carburetor
 - Fuel strainer clogged
 - Fuel hose clogged
 - Fuel valve stuck
 - Float level misadjusted
 - Fuel tank breather hole clogged

Lean mixture

- Fuel jet clogged
- Float valve faulty
- Float level too low
- Fuel line restricted
- Intake air leak
- Throttle valve faulty
- Carburetor air vent hose clogged

Rich mixture

- Choke valve in closed position
- Float valve faulty
- Float level too high
- Air jets clogged
- Flooded carburetor
- Air cleaner clogged

Engine stall, hard to start, rough idling

- Fuel line restricted
- Ignition system malfunction
- Fuel mixture too lean/rich (pilot screw adjustment)
- Fuel contaminated/deteriorated
- Intake air leak
- Idle speed misadjusted
- Float level misadjusted
- Air cleaner clogged
- Slow circuit clogged
- Ignition system faulty

Afterburn when engine braking is used

- Lean mixture in slow circuit
- Air cut-off valve malfunction
- Faulty pulse secondary air injection (PAIR) system
 - Faulty PAIR control valve
 - Faulty PAIR check valve
 - Clogged hose of the PAIR system
- Ignition system faulty

Backfiring or misfiring during acceleration

- Ignition system malfunction
- Fuel mixture too lean

Poor performance (driveability) and poor fuel economy

- Fuel system clogged
- Ignition system malfunction

AIR CLEANER HOUSING

REMOVAL

Remove the following:

- Battery (page 15-6)
- Fuel tank (page 2-4)

Remove the fuel tank center cushion.

Pull out the air cleaner sub filter-to-open air hose from the hole of the air cleaner housing.

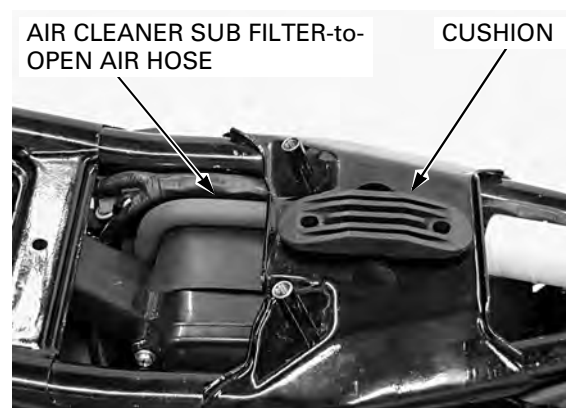

Loosen the air cleaner connecting hose band screw.

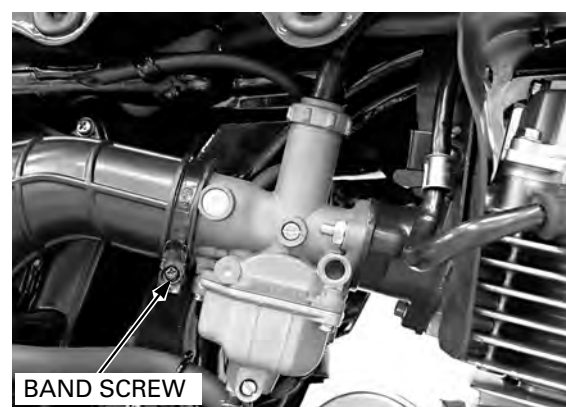

Disconnect the crankcase breather hose.

Remove the four screws and the air cleaner housing cover.

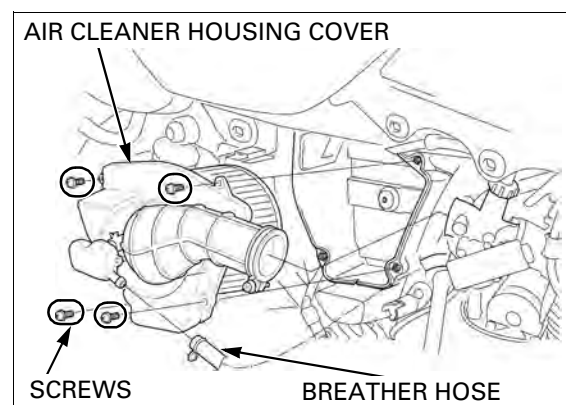

Remove the following:

- Two bolts
- Bolt/collar
- Air cleaner housing bracket
- Two screws
- Tool box lid
- Fuse box (from the clamp)

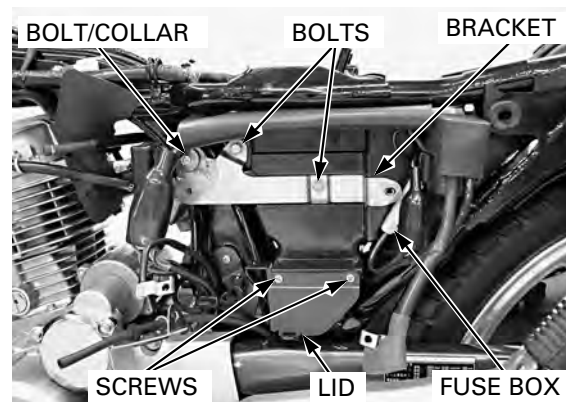

FUEL SYSTEM

Release the boss of the tool box from the grommet by slightly pulling up the air cleaner housing.

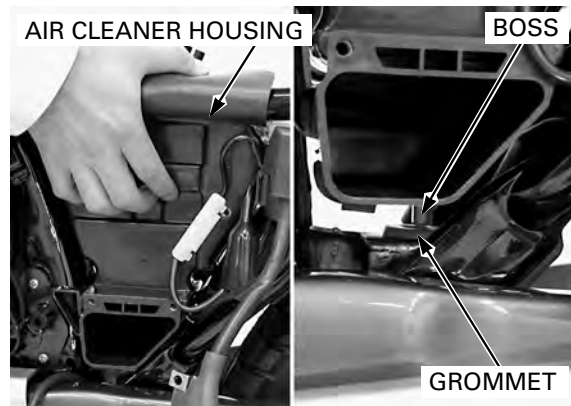

Pull out the tool box and remove the air cleaner housing from the right side of the motorcycle.

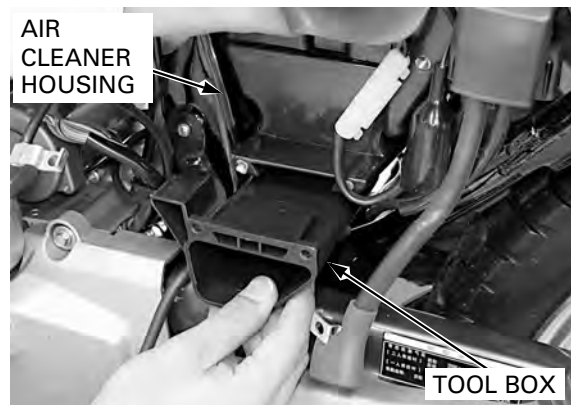

INSTALLATION

Install the air cleaner housing from the right side of the motorcycle.

Install the tool box from the left side of the motorcycle by inserting the tab of the tool box into the slot of the air cleaner housing.

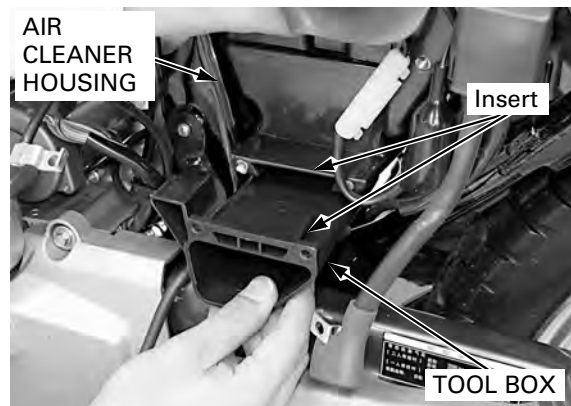

Set the air cleaner housing in position by inserting the boss on the bottom of the tool box to the grommet.

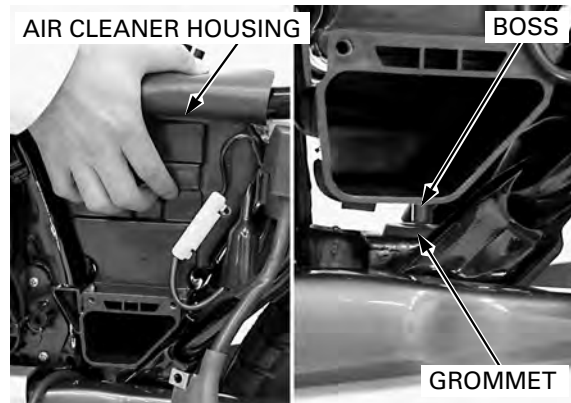

FUEL SYSTEM

Install the tool box lid and tighten the two screws to the specified torque.

TORQUE: 1.8 N·m (0.2 kgf·m, 1.3 lbf·ft)

Install the following:

- Fuse box (to the clamp)
- Air cleaner housing bracket
- Bolt/collar
- Two bolts

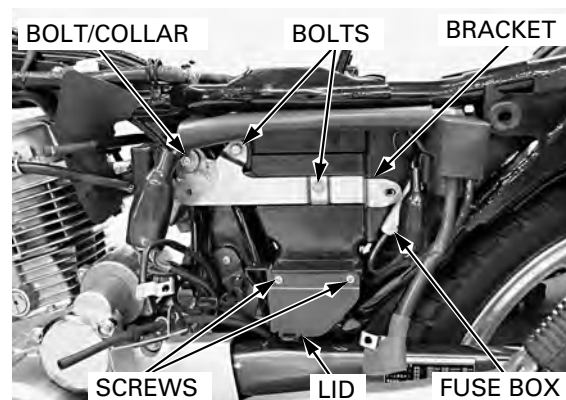

Install the air cleaner housing cover and tighten the four screws to the specified torque.

TORQUE: 1.8 N·m (0.2 kgf·m, 1.3 lbf·ft)

Connect the crankcase breather hose to the storage tank.

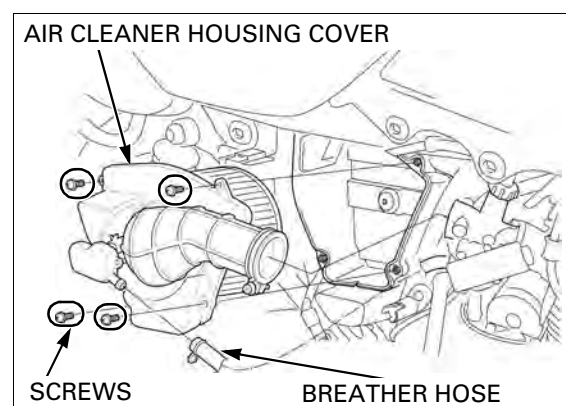

Tighten the air cleaner connecting hose band screw.

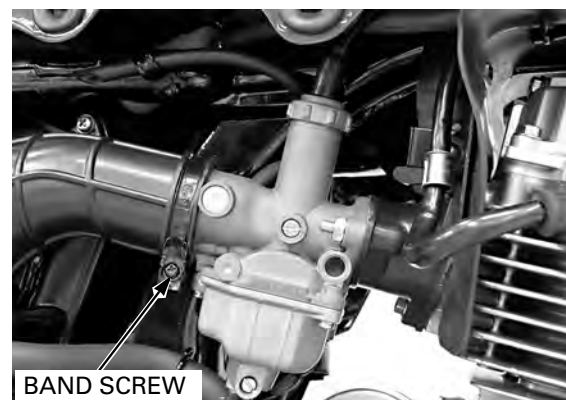

Insert the air cleaner sub filter-to-open air hose into the hole of the air cleaner housing.

Install the fuel tank center cushion by aligning the bosses of the air cleaner housing with the grommets of the cushion.

Install the following:

- Fuel tank (page 2-4)
- Battery (page 15-6)

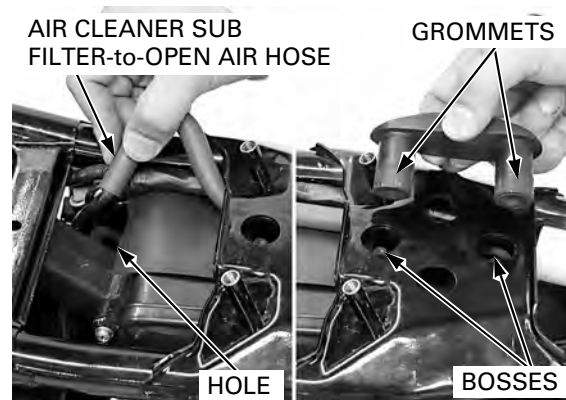

FUEL SYSTEM

STORAGE TANK

Remove the crankcase breather hose, clip and storage tank.

Check the breather hose for deterioration, damage or loose connection. Make sure that the hose is not cracked.

Check the storage tank for clogging, damage or fatigue.

Installation is in the reverse order of removal.

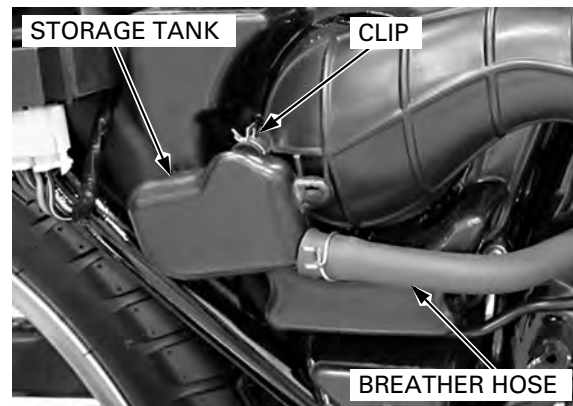

THROTTLE VALVE

REMOVAL

Remove the right side cover (page 2-3).

Blow the dust off around the carburetor before removing the carburetor top.

Loosen the carburetor top.

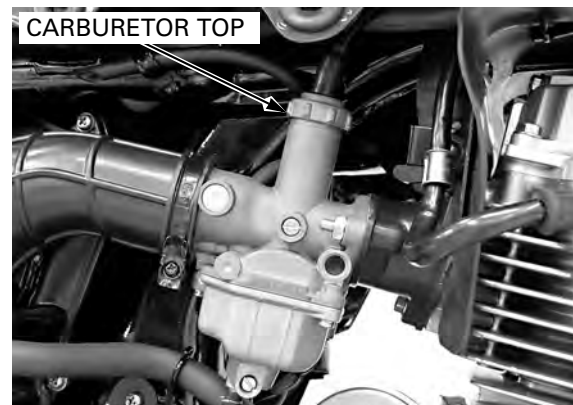

Be careful not to damage the jet needle when removing the throttle valve from the carburetor body.

Remove the carburetor top and throttle valve from the carburetor.

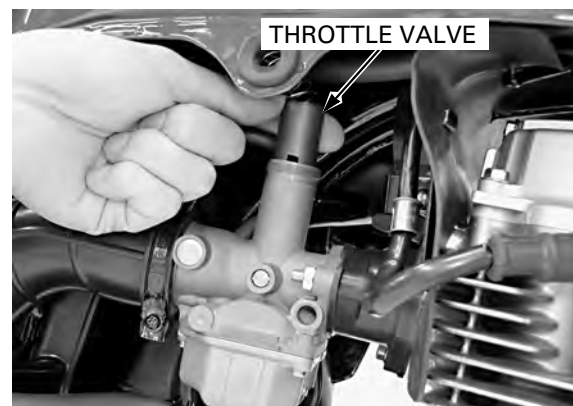

Remove the throttle cable from the throttle valve while compressing the throttle valve spring.

Remove the throttle valve spring.

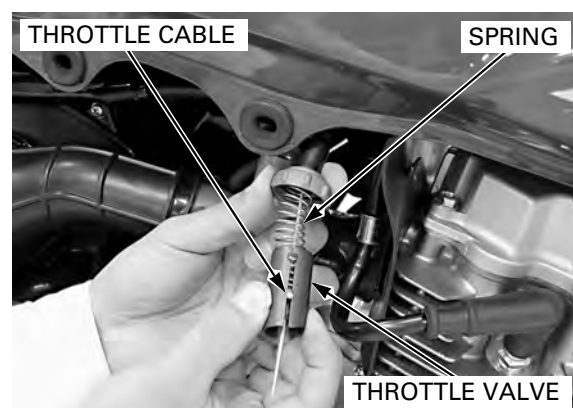

Turn the jet needle retainer counterclockwise until it clicks and is unlocked.

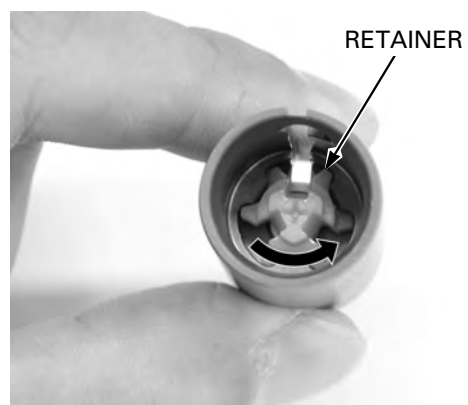

Remove the jet needle retainer, spring and jet needle from the throttle valve.

Check the throttle valve and jet needle for scratch, wear or damage.

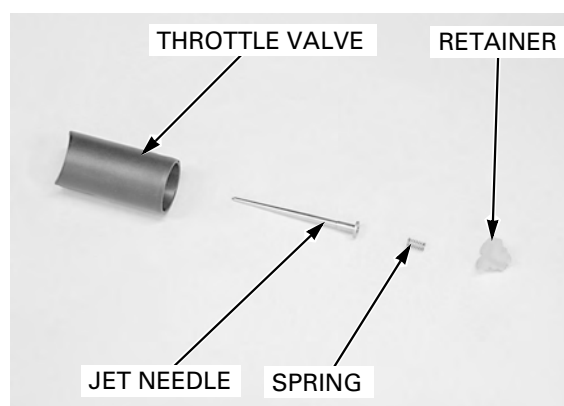

INSTALLATION

Install the jet needle, spring and jet needle retainer to the throttle valve.

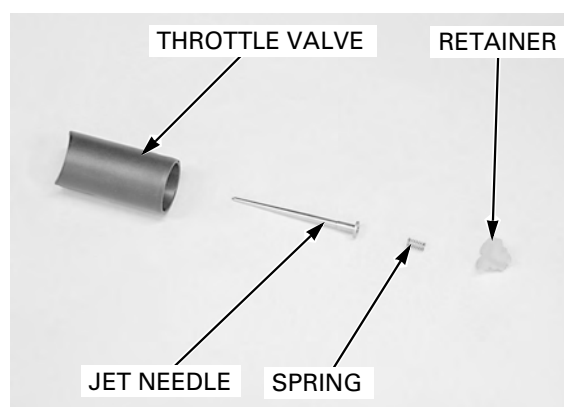

Rotate the jet needle retainer clockwise until it clicks and is locked.

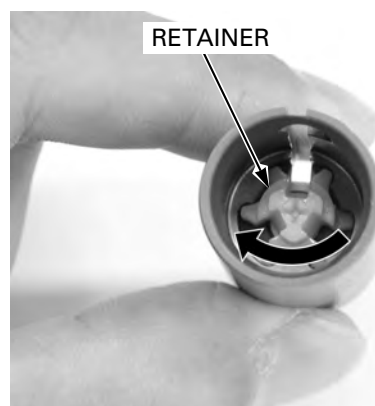

FUEL SYSTEM

Set the throttle valve spring between the carburetor top and the throttle valve.
Connect the throttle cable to the throttle valve while compressing the throttle valve spring.

Be careful not to damage the jet needle when installing the throttle valve to the carburetor body.

Install the throttle valve into the carburetor body, aligning its cut-out with the throttle stop screw.

Tighten the carburetor top.

Install the right side cover (page 2-3).

After installation, check the throttle valve operation.

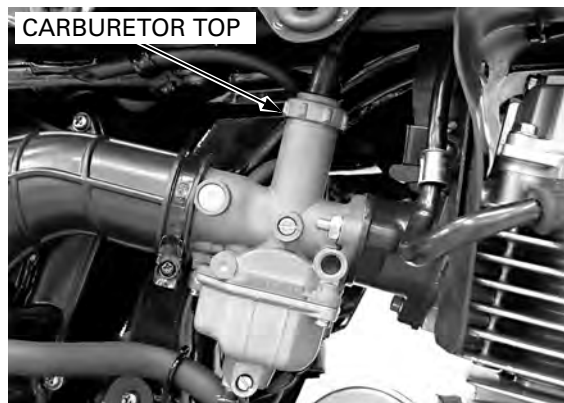
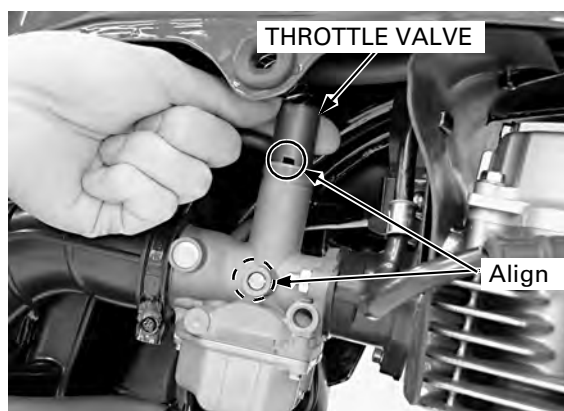
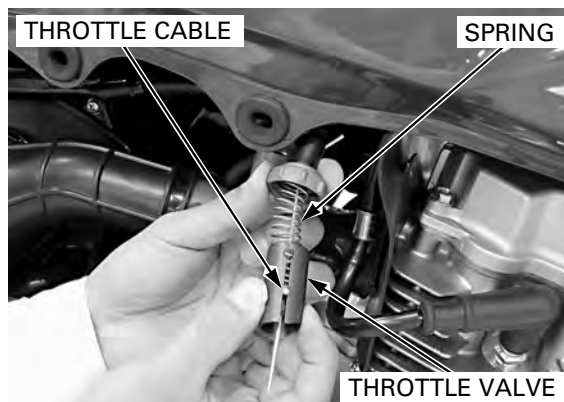

CARBURETOR REMOVAL

REMOVAL

Remove the right and left side covers (page 2-3).
Remove the throttle valve (page 5-8).

Turn the fuel valve "OFF" and disconnect the fuel hose from the fuel valve.

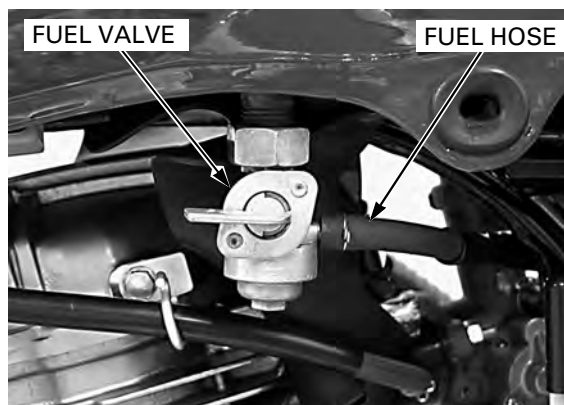

FUEL SYSTEM

Loosen the drain screw and drain the fuel from the float chamber into the approved gasoline container.

Completely drain any residual fuel and tighten the drain screw to the specified torque.

TORQUE: 1.5 N·m (0.2 kgf·m, 1.1 lbf·ft)

Release the air vent hose from the clamp.

Disconnect the drain hose from the carburetor.

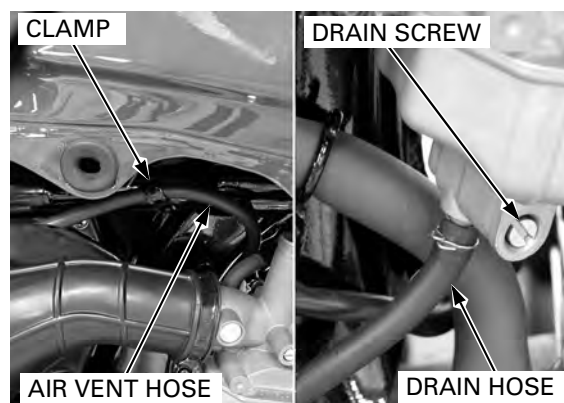

Loosen the air cleaner connecting hose band screw. Remove the carburetor mounting nuts and carburetor.

Remove the O-ring from the carburetor.

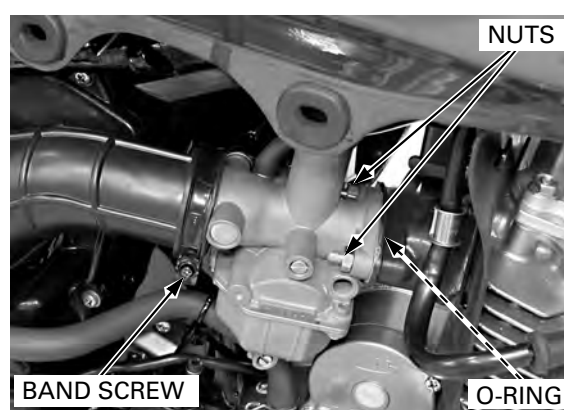

Disconnect the air vent hose and the fuel hose from the carburetor.

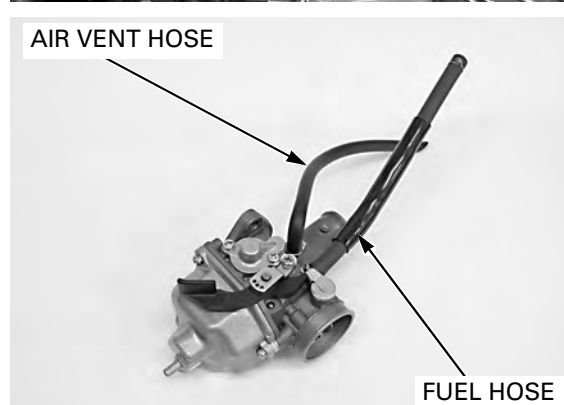

CHOKE LEVER

REMOVAL

Remove the carburetor (page 5-10).

Remove the screw and setting plate.

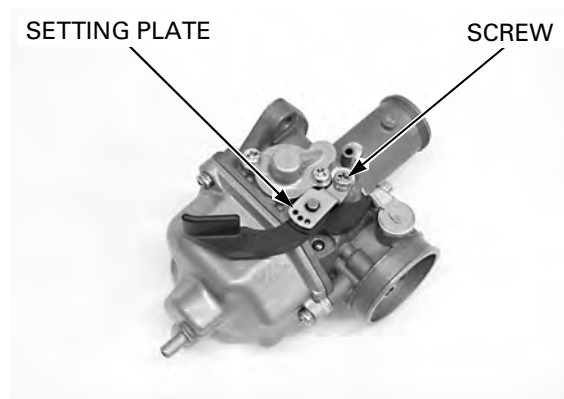

FUEL SYSTEM

Remove the choke lever.

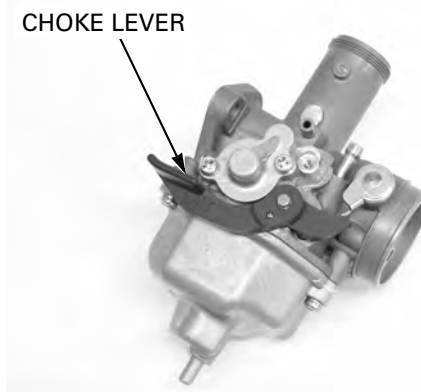

INSTALLATION

Install the choke lever to the carburetor.

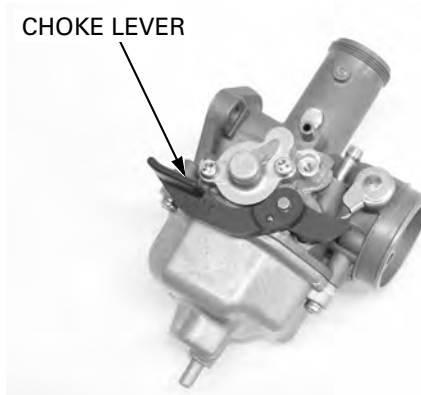

Install the setting plate, aligning the choke lever ball with setting plate hole.

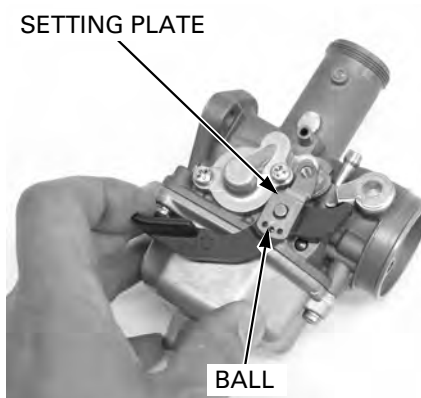

Install and tighten the choke lever screw to the specified torque.

TORQUE: 2.1 N·m (0.2 kgf·m, 1.5 lbf·ft)

Check the choke lever operation.

Install the carburetor (page 5-19).

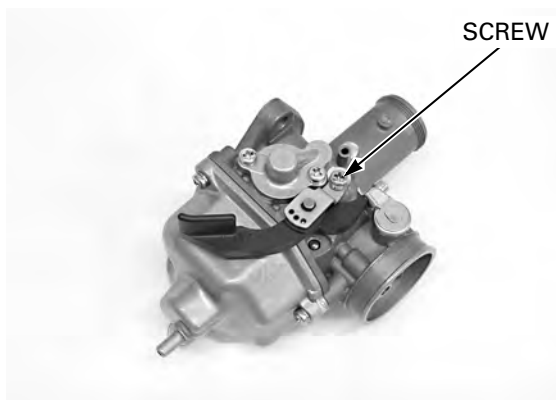

AIR CUT-OFF VALVE

REMOVAL

Be careful when removing the valve cover. The spring may pop out.

Remove the carburetor (page 5-10).
Remove the two screws and valve cover.

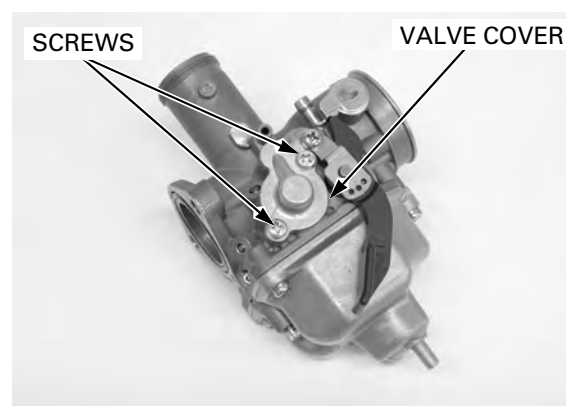

Remove the spring and check it for deterioration.

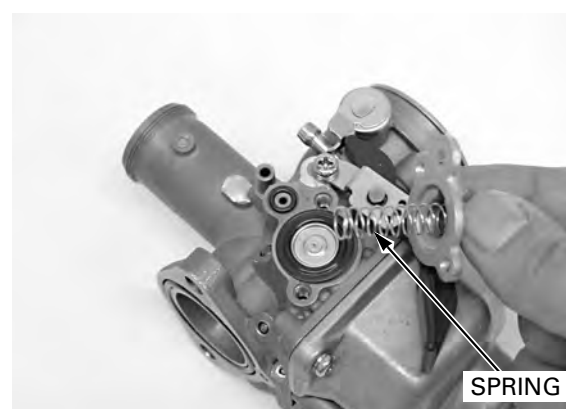

Remove the O-ring and diaphragm.

Check the following:

- Diaphragm for pin holes, deterioration or damage
- Needle of diaphragm for damage
- Air passages for clogging

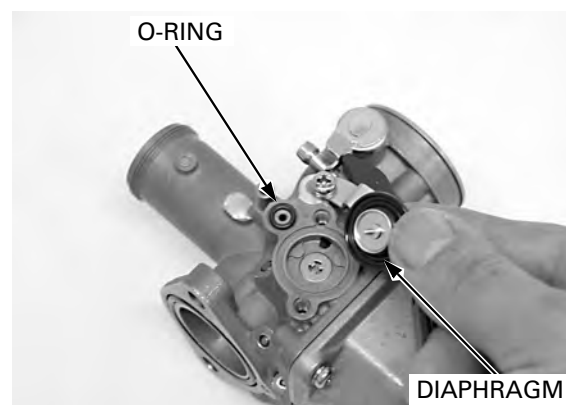

INSTALLATION

Be sure that the diaphragm and O-ring do not interfere with the cover.

Install a new O-ring with the flat side facing the carburetor body.

Install the following:

- Diaphragm
- Spring
- Air cut-off valve cover

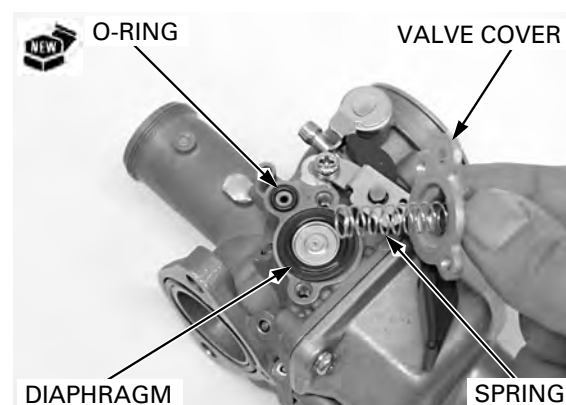

FUEL SYSTEM

Install and tighten the screws to the specified torque.

TORQUE: 2.1 N·m (0.2 kgf·m, 1.5 lbf·ft)

Install the carburetor (page 5-19).

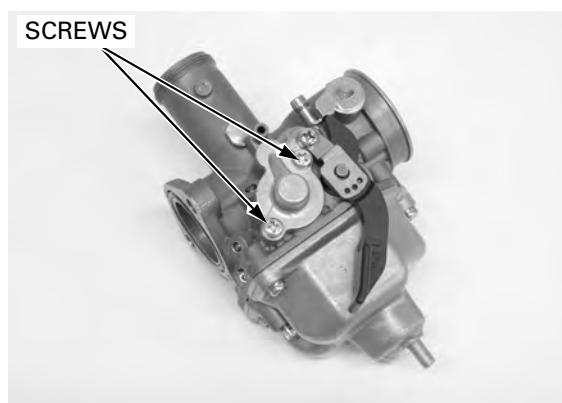

CARBURETOR DISASSEMBLY

FLOAT

Remove the three screws and float chamber.

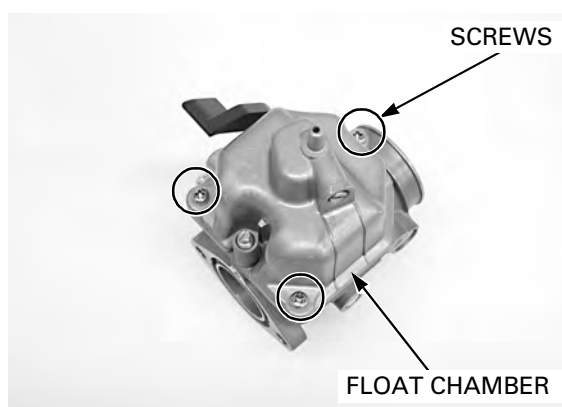

Pull out the float pin.

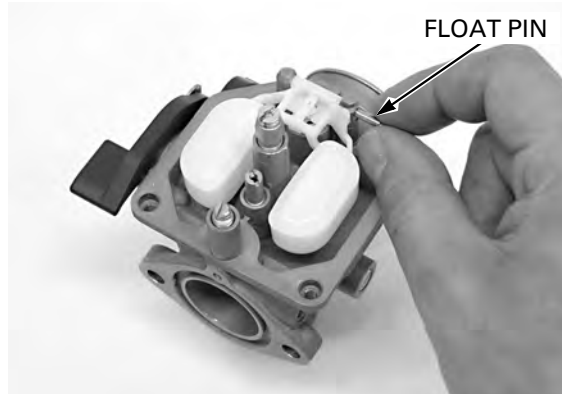

Remove the float and float valve.

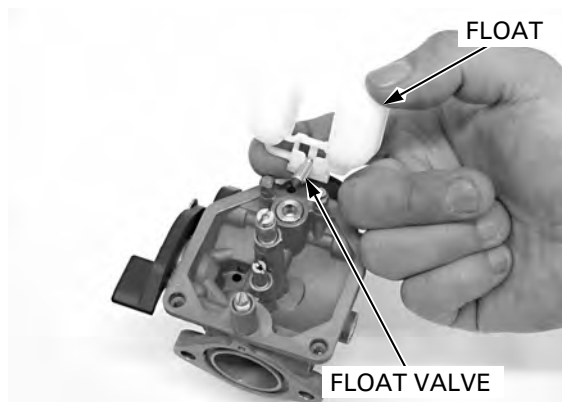

JETS

Remove the following:

- Main jet
- Slow jet
- Needle jet holder
- Needle jet
- Throttle stop screw/O-ring/spring

Damage to the pilot screw seat will occur if the screw is tightened against the seat.

Before removing the pilot screw, record the number of turns until it seats lightly, then remove the pilot screw, spring, washer and O-ring.

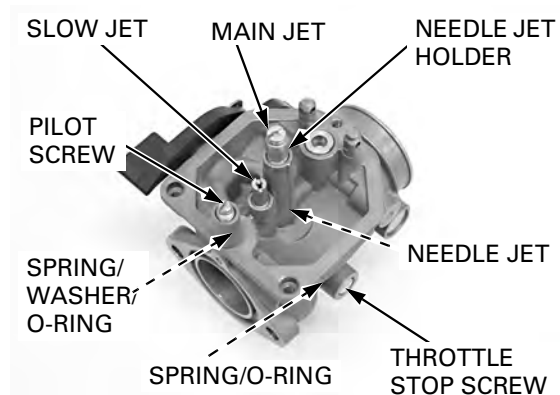

Check each jet for wear or damage.

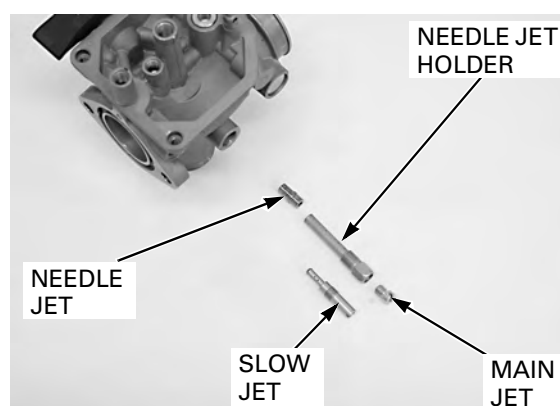

Check the pilot screw, spring, washer and O-ring. Check the throttle stop screw, spring and O-ring.

Replace the damaged parts, if necessary.

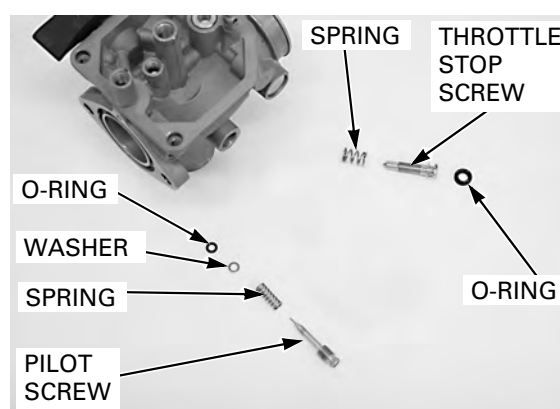

CARBURETOR BODY CLEANING

Blow each air and fuel passage in the carburetor body with compressed air.

Check each part for wear or damage and replace them if necessary.

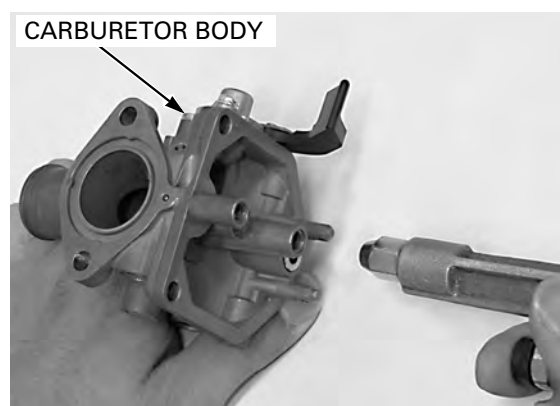

FUEL SYSTEM

CARBURETOR ASSEMBLY

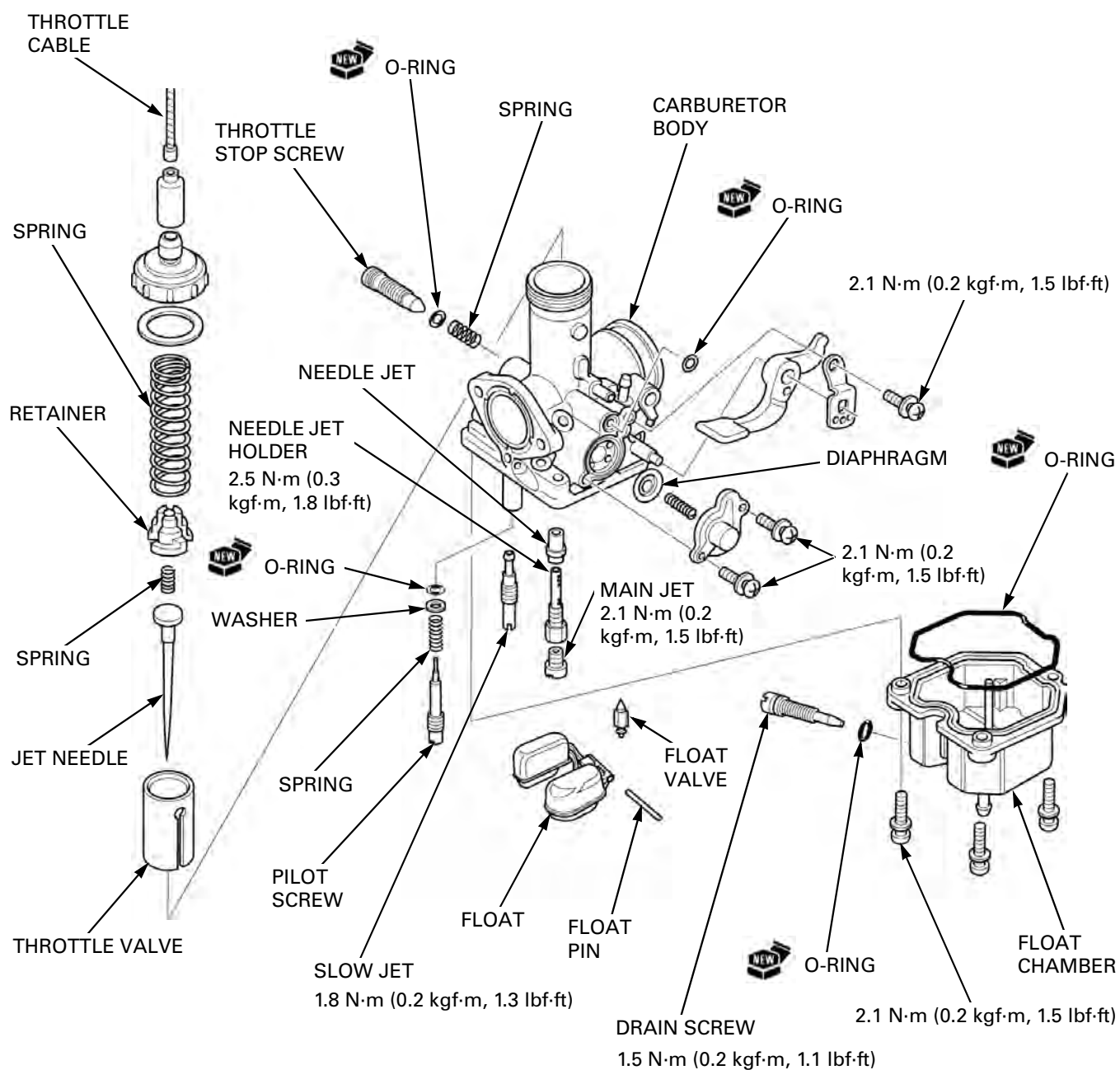

JETS

Install a new O-ring to the throttle stop screw.

Install the spring and throttle stop screw.

Install a new O-ring, washer, spring and pilot screw and return it to its original as noted during removal.

Perform the pilot screw adjustment procedure if a new pilot screw is installed (page 5-21).

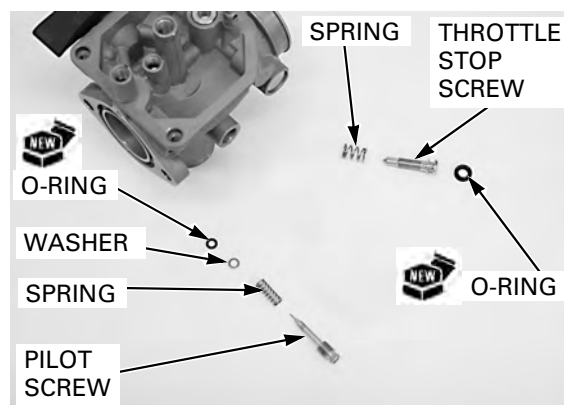

FUEL SYSTEM

Handle all jets with care. They can easily be scored or scratched.

Install the needle jet.

Install and tighten the slow jet, needle jet holder and main jet to the specified torque.

TORQUES:

Slow jet: 1.8 N·m (0.2 kgf·m, 1.3 lbf·ft)

Needle jet holder: 2.5 N·m (0.3 kgf·m, 1.8 lbf·ft)

Main jet: 2.1 N·m (0.2 kgf·m, 1.5 lbf·ft)

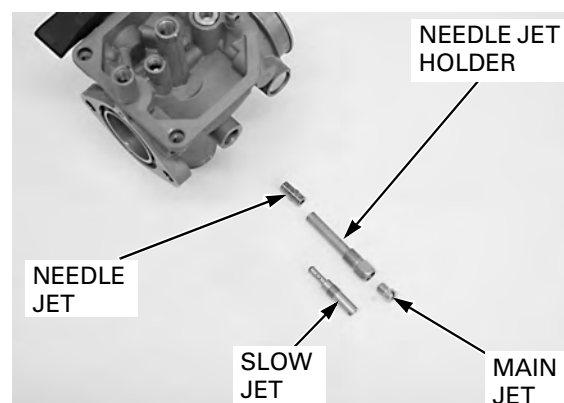

FLOAT

Check the tip of the float valve where it contacts the valve seat for stepped wear or contamination.

Replace the valve if the tip is worn or contaminated.

Check the operation of the float valve.

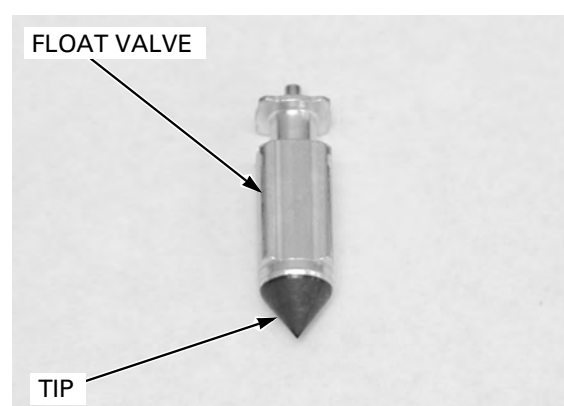

Inspect the float valve seat for scores, scratches, clogging and damage.

If the seat is damaged, replace the carburetor body.

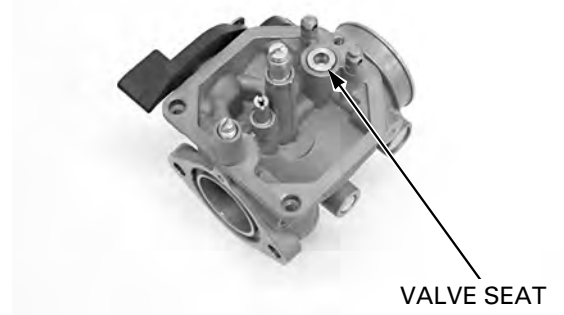

Install the float valve to the float.

Install the float to the carburetor body.

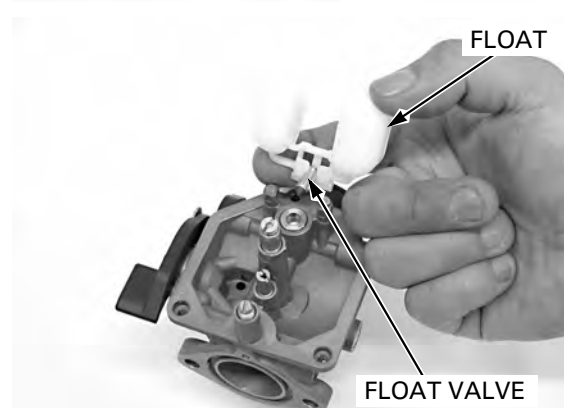

FUEL SYSTEM

Install the float pin through the body and float.

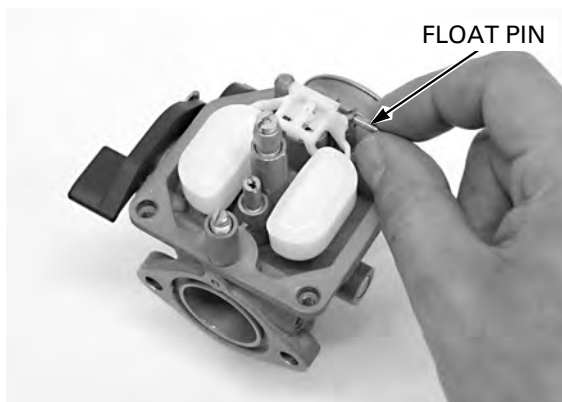

With the float valve seated and the float arm just touching the valve, measure the float level with the special tool as shown.

FLOAT LEVEL: 14.0 mm (0.55 in)

TOOL:

Carburetor float level gauge 07401-001000

The float cannot be adjusted.
Replace the float assembly if the float level is out of specification.

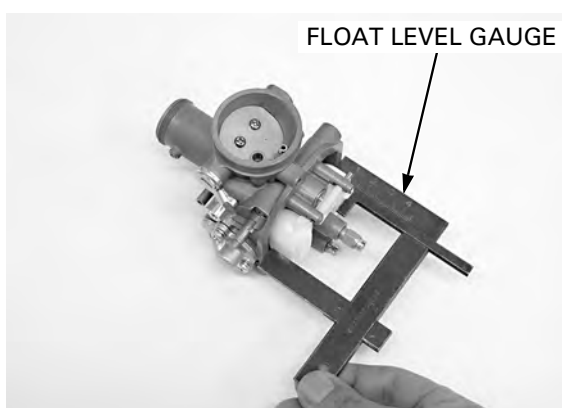

Install a new O-ring into the float chamber groove.
Install the float chamber.

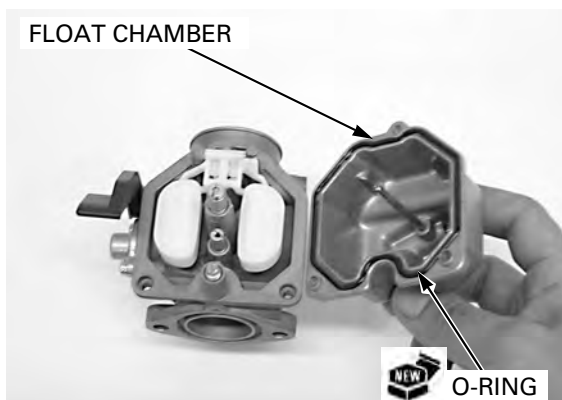

Install and tighten the float chamber screws to the specified torque.

TORQUE: 2.1 N·m (0.2 kgf·m, 1.5 lbf·ft)

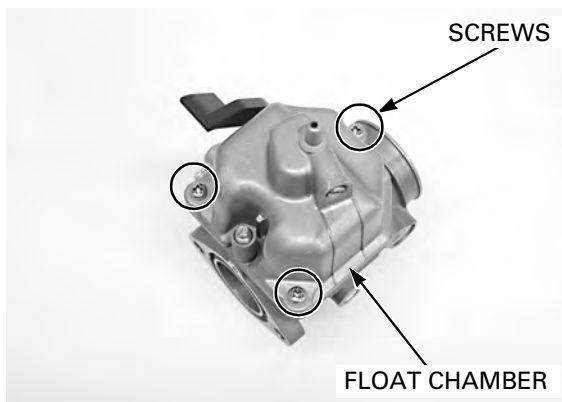

CARBURETOR INSTALLATION

Connect the air vent hose and the fuel hose to the carburetor.

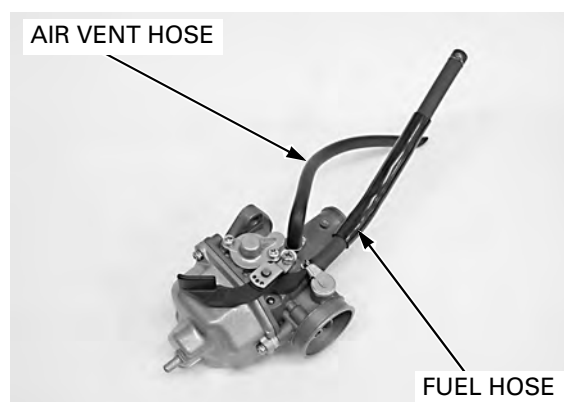

Install a new O-ring onto the carburetor.



Install the carburetor to the insulator and air cleaner connecting hose.

Tighten the carburetor mounting nuts and air cleaner connecting hose band screw.

Install the throttle valve (page 5-9)

Install the right side cover (page 2-3)



Connect the drain hose to the carburetor.

Set the air vent hose to the clamp.

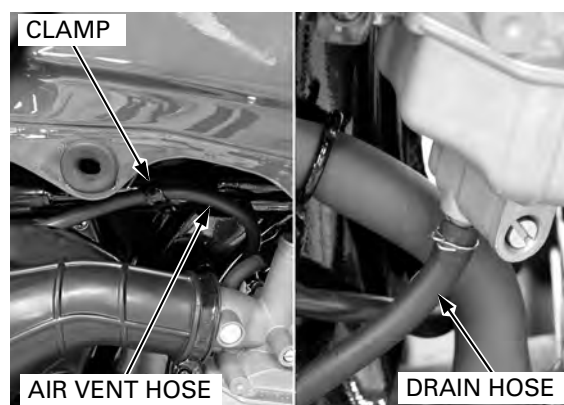

FUEL SYSTEM

After installation, turn the fuel valve "ON" and make sure there are no fuel leaks.

Connect the fuel hose to the fuel valve.

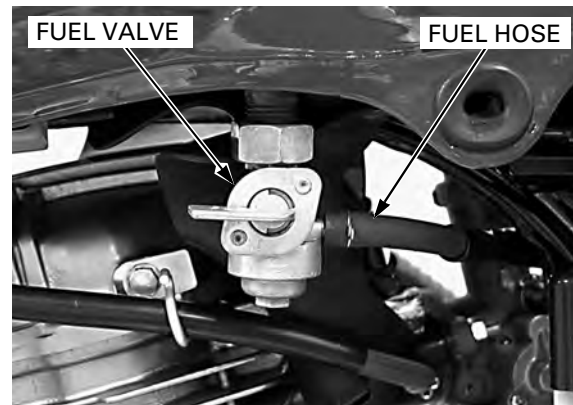

INSULATOR

REMOVAL

Remove the carburetor (page 5-10)
Remove the two bolts, clamp and insulator.
Remove the O-ring from the insulator.

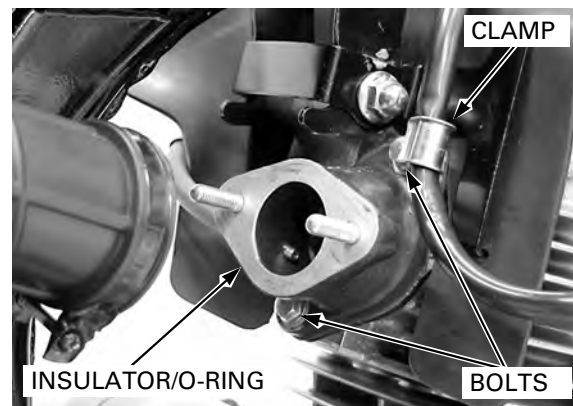

INSTALLATION

Install a new O-ring onto the insulator.
Install the insulator and clamp.
Install and tighten the bolts.
Install the carburetor (page 5-19)

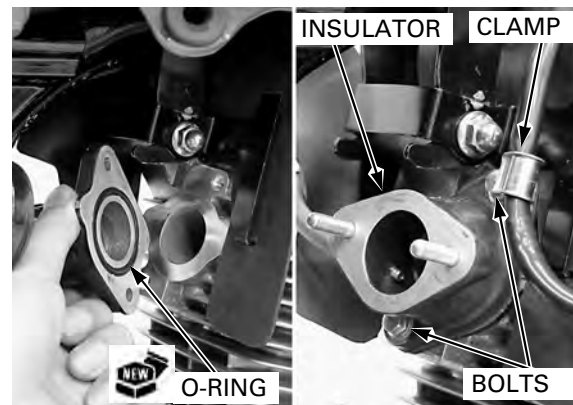

PILOT SCREW ADJUSTMENT

- The pilot screw are factory pre-set and no adjustment is necessary unless the pilot screw is replaced.
- The engine must be warm for accurate adjustment. 10 minutes of stop-and-go riding is sufficient.
- Use a tachometer with graduations of 50 min⁻¹ (rpm) or smaller that will accurately indicate a 50 min⁻¹ (rpm) change.

IDLE DROP PROCEDURE

Damage to the pilot screw seat will occur if the pilot screw is tightened against the seat.

1. Turn the pilot screw clockwise until it is lightly seated then back it out to the specification given. This is an initial setting prior to the final pilot screw adjustment.

INITIAL OPENING: UNDECIDED

2. Warm up the engine to operating temperature.
3. Stop the engine and connect a tachometer according to the tachometer manufacturer's instructions.

4. Disconnect the PAIR control valve vacuum hose, then connect it to the vacuum pump and plug the vacuum port.

TOOL:

Vacuum pump **Commercially available**

5. Apply the specified vacuum to the PAIR control valve vacuum hose more than 60 kPa (450 mm Hg).

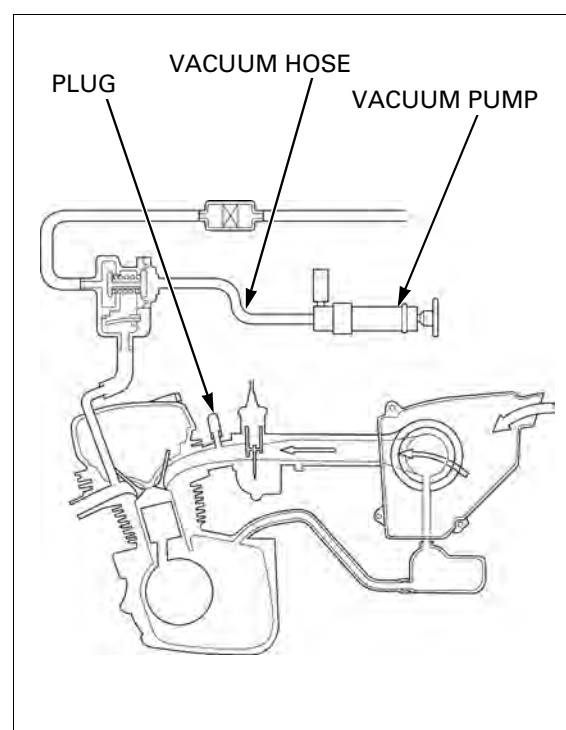
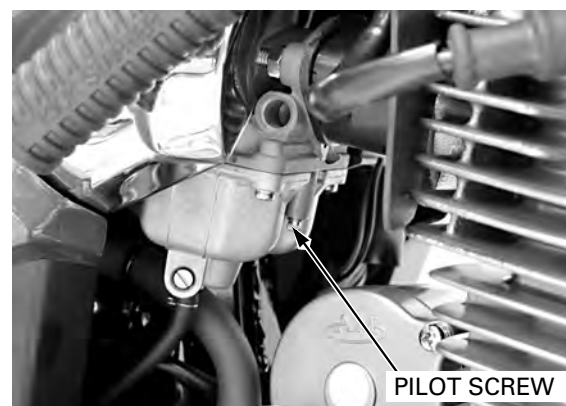

FUEL SYSTEM

6. Start the engine and adjust the idle speed with the throttle stop screw.

IDLE SPEED: $1,300 \pm 100 \text{ min}^{-1}$ (rpm)

7. Turn the pilot screw inward or outward slowly to obtain the highest engine speed.
8. Lightly open the throttle 2 – 3 times, then adjust the idle speed with the throttle stop screw.

IDLE SPEED: $1,300 \pm 100 \text{ min}^{-1}$ (rpm)

9. Turn the pilot screw inward gradually until the engine speed drops by **UNDECIDED** min^{-1} (rpm).
10. Turn the pilot screw outward to the final opening.

FINAL OPENING: UNDECIDED

11. Remove the plug from the vacuum port, then remove the vacuum pump and connect the vacuum hose to the vacuum port.

12. Readjust the idle speed with the throttle stop screw.

IDLE SPEED: $1,400 \pm 100 \text{ min}^{-1}$ (rpm)

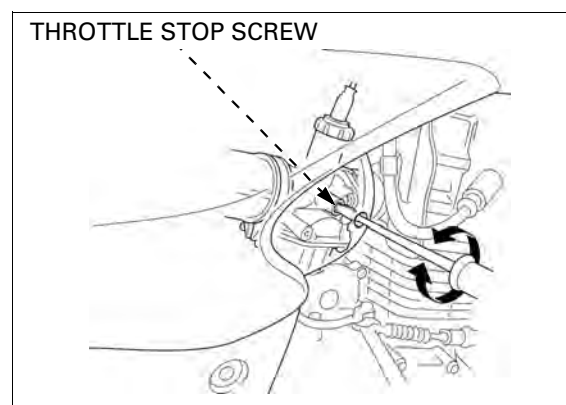

SECONDARY AIR SUPPLY SYSTEM

SYSTEM INSPECTION

Remove the following:

- Right and left side covers (page 2-3).
- Right and left horn covers (page 2-7).

Start the engine and warm it up to normal operating temperature.

Remove the fuel tank (page 2-4).

Disconnect the air cleaner sub filter-to-PAIR control valve hose.

Check that the hose joint of the sub filter is clean and free of carbon deposits.
Replace the sub filter if necessary.

If the port is carbon fouled, inspect the PAIR check valve.

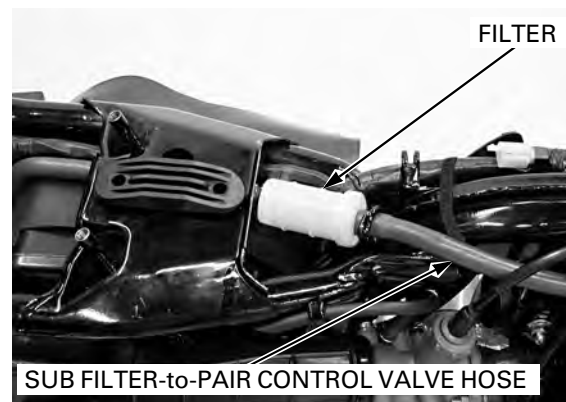

The sub filter has a direction mark.

Install the sub filter in the reverse order of removal.

Disconnect the PAIR control valve vacuum hose from the joint of the insulator and plug it to keep air from entering.
Connect the vacuum pump to the PAIR control valve vacuum hose.

TOOL:
Vacuum pump **Commercially available**

Start the engine and open the throttle slightly to be certain that air is sucked in through the PAIR air cleaner sub filter-to-open air hose.
If the air is not sucked in, check the PAIR air cleaner sub filter-to-PAIR control valve hose, PAIR air cleaner sub filter and PAIR air cleaner sub filter-to-open air hose for clogging.

With the engine running, gradually apply vacuum to PAIR control valve.
Check that the air intake port stops drawing air, and that the vacuum does not bleed.

SPECIFIED VACUUM: 60 kPa (450 mm Hg)

If the air is drawn in, or if the specified vacuum is not maintained, replace the PAIR control valve.

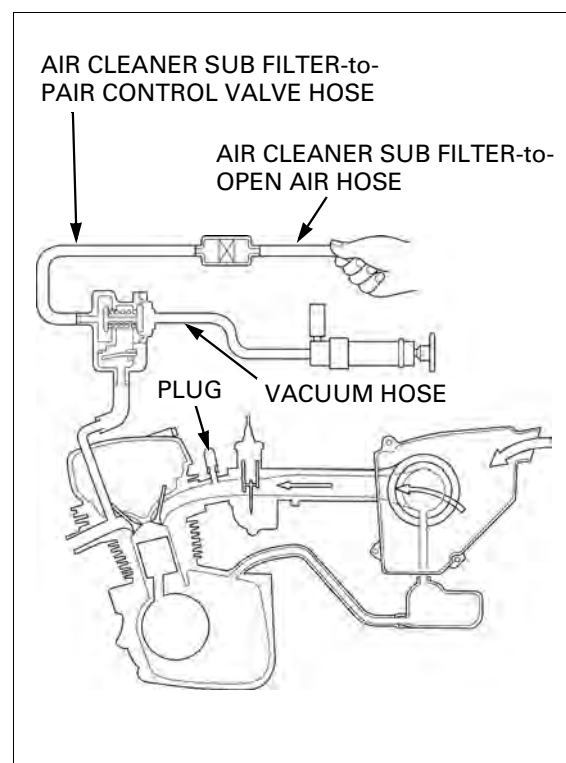

PAIR CHECK VALVE INSPECTION

Remove the left horn cover (page 2-7).

Remove the two screws and valve cover.
Remove the PAIR check valve.

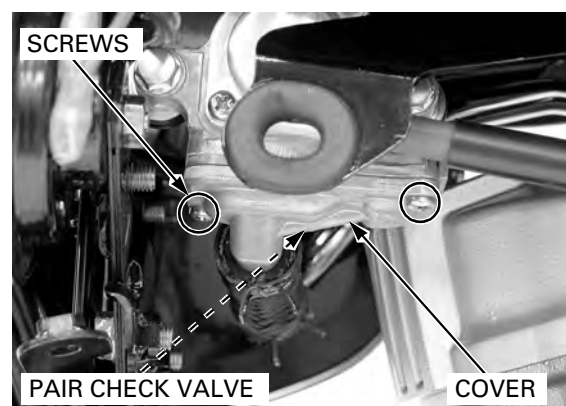

Check the valve reed for fatigue or damage.
Replace the PAIR control valve if the seat rubber is cracked, deteriorated or damaged, or if there is clearance between the reed and seat.



FUEL SYSTEM

Install the PAIR check valve.



Install the PAIR check valve cover and tighten the screws.

Install the left horn cover (page 2-7).

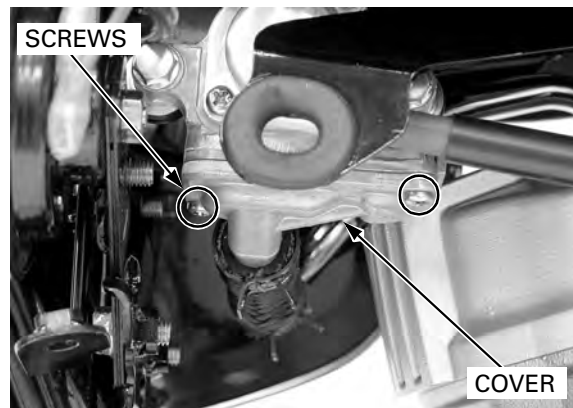

PAIR CONTROL VALVE REMOVAL/ INSTALLATION

Remove the following:

- Right and left horn covers (page 2-7)
- Fuel tank (page 2-4)

Unhook the PAIR control valve vacuum hose from the clamp, remove the horn cover stay mounting bolt and the horn cover stays.

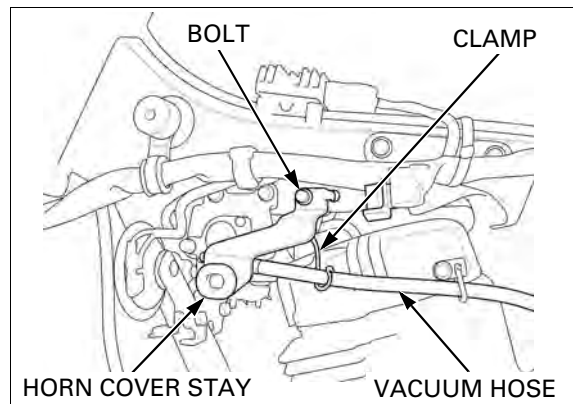

Disconnect the PAIR control valve vacuum hose.



FUEL SYSTEM

Disconnect the air cleaner sub filter-to-PAIR control valve hose.

Release the PAIR control valve side clamp.

Remove the PAIR control valve mounting nuts.

Disconnect the air supply pipe-to-PAIR control valve hose from the PAIR control valve.

Remove the PAIR control valve.

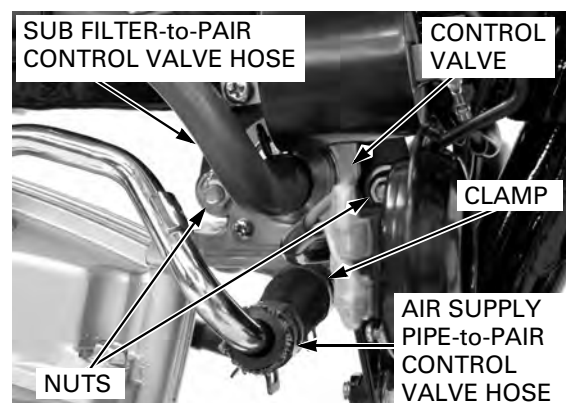

Connect the air supply pipe-to-PAIR control valve hose to the PAIR control valve.

Set the PAIR control valve and tighten the PAIR control valve mounting nuts to the specified torque.

TORQUE: PAIR control valve mounting nut:
9 N·m (0.9 kgf·m, 6.6 lbf·ft)

Set the PAIR control valve side clamp in position.

Connect the air cleaner sub filter-to-PAIR control valve hose.

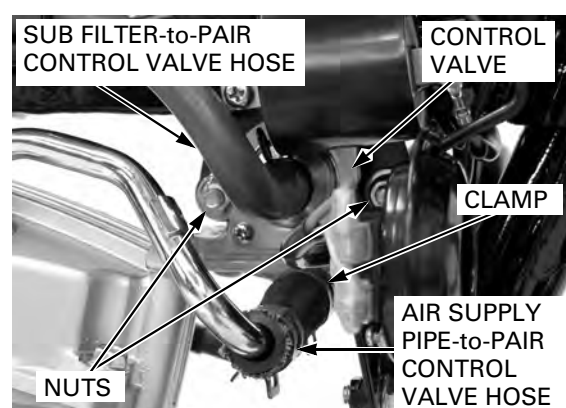

Connect the PAIR control valve vacuum hose.



Set the horn cover stays by inserting the tabs of the horn cover stays into the hole of the frame. Install and tighten the horn cover stay mounting bolt.

Set the PAIR control valve vacuum hose to the clamp.

Install the following:

- Fuel tank (page 2-4)
- Right and left horn covers (page 2-7)

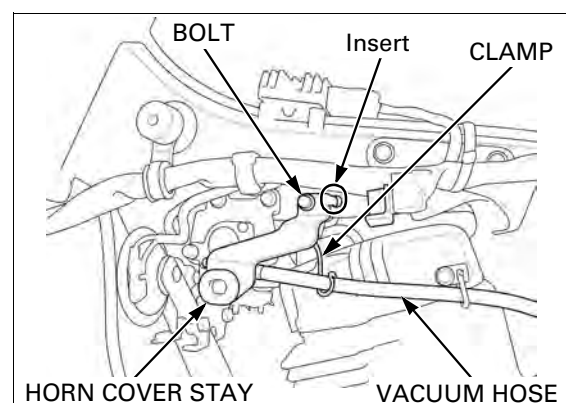

FUEL SYSTEM

FUEL STRAINER

REMOVAL

Drain the fuel from the fuel tank.

Remove the fuel tank (page 2-4).

Loosen the fuel valve lock nut.

Remove the fuel strainer and fuel valve assembly from the fuel tank.

Remove the fuel strainer and O-ring from the fuel valve.

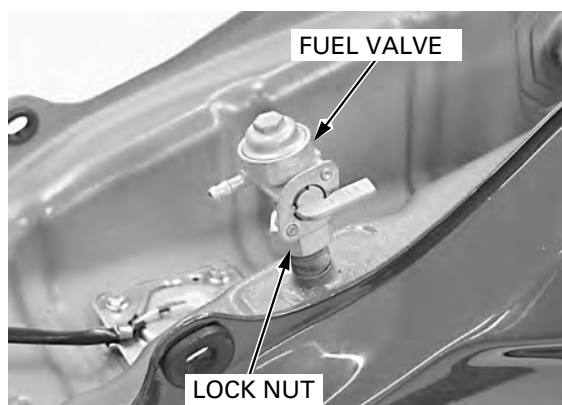

CLEANING

Clean the fuel strainer with compressed air.

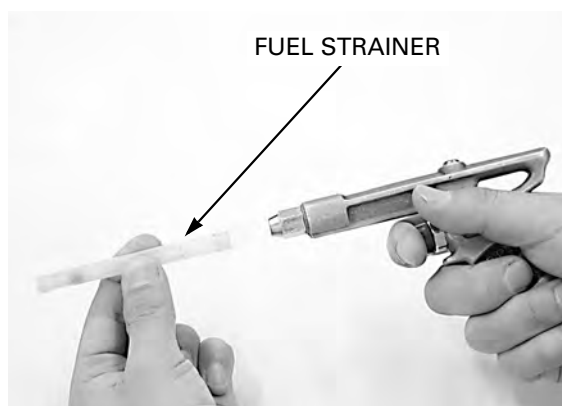

INSTALLATION

Install a new O-ring onto the fuel strainer, and install the fuel strainer into the fuel valve.

Install the fuel strainer and fuel valve assembly into the fuel tank.

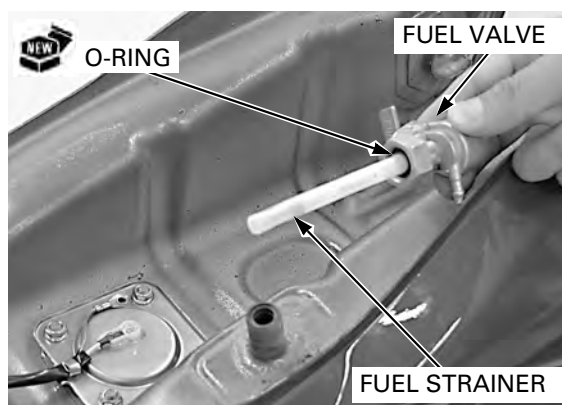

Tighten the fuel valve lock nut.

Install the fuel tank (page 2-4).

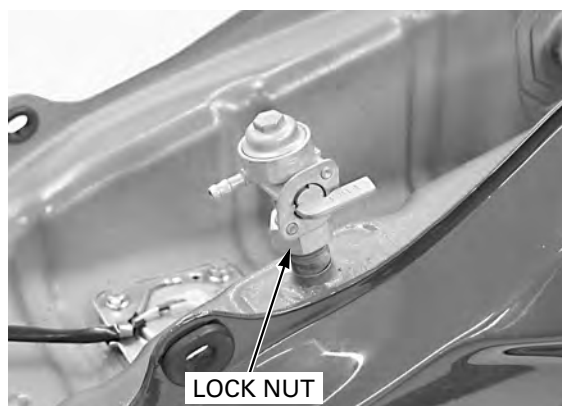

6. ENGINE REMOVAL/INSTALLATION

SYSTEM COMPONENTS	6-2	ENGINE REMOVAL	6-6
SERVICE INFORMATION	6-3	ENGINE INSTALLATION	6-10
DRIVE SPROCKET	6-4		

ENGINE REMOVAL/INSTALLATION

SYSTEM COMPONENTS

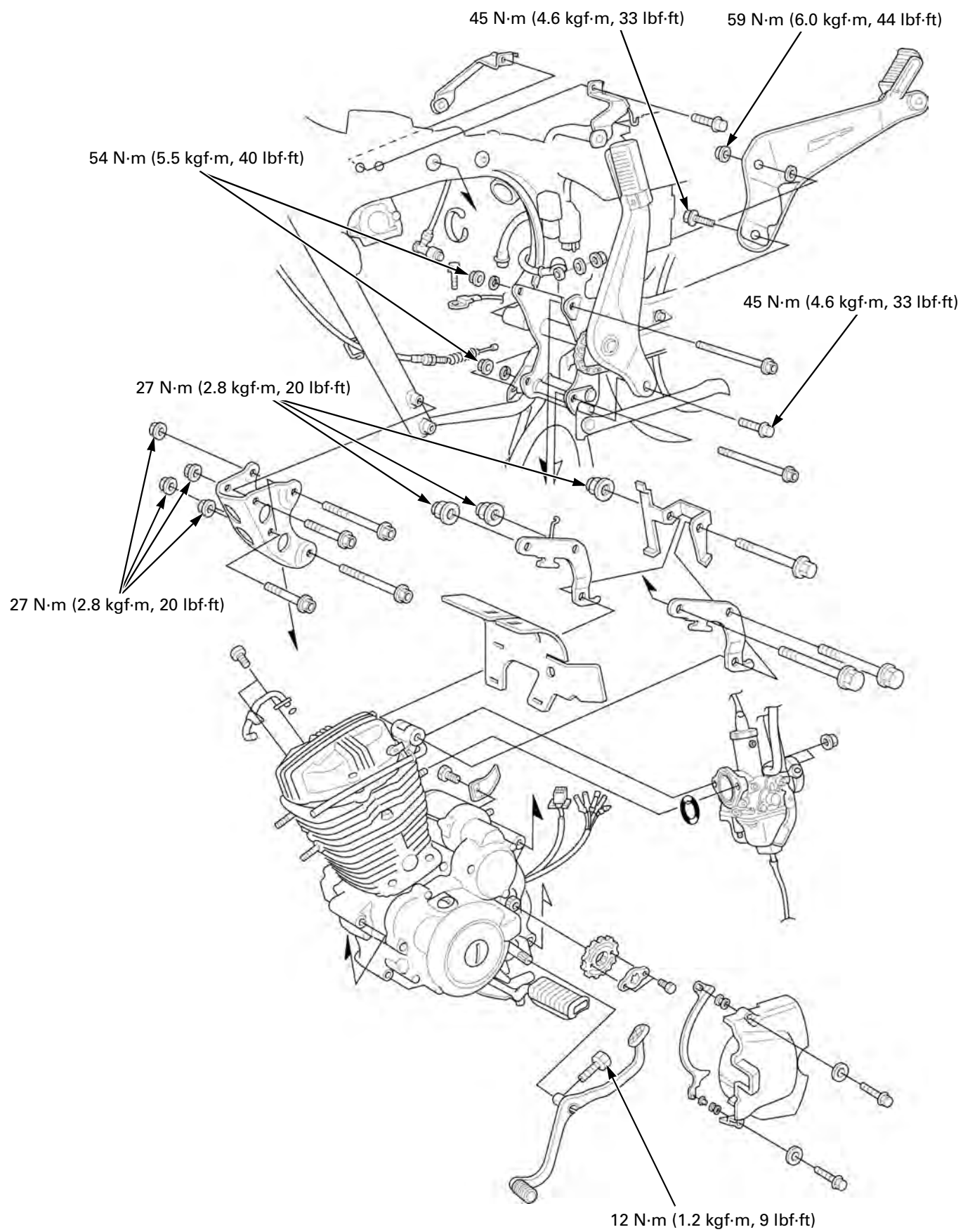

SERVICE INFORMATION**GENERAL**

- Place the motorcycle on level ground before starting any work.
- When removing/installing the engine, tape the frame around the engine beforehand for frame protection.
- Support the engine using a floor jack or other adjustable support to ease engine hanger bolt stresses.
- The following components require engine removal for service.
 - Cylinder head/valves (page 7-12)
 - Cylinder/piston (page 8-4/8-10)
 - Crankshaft (page 11-7)
 - Transmission (page 11-8)
 - Kickstarter (page 11-14)

SPECIFICATIONS

ITEM		SPECIFICATIONS
Engine oil capacity	After draining	0.8 liter (0.8 US qt, 0.7 Imp qt)
	After disassembly	1.1 liter (1.2 US qt, 1.0 Imp qt)
Engine dry weight		30.5 kg (67.2 lbs)

TORQUE VALUES

Upper engine hanger plate mounting nut	27 N·m (2.8 kgf·m, 20 lbf·ft)
Front engine hanger bracket mounting nut	27 N·m (2.8 kgf·m, 20 lbf·ft)
Swingarm pivot nut	59 N·m (6.0 kgf·m, 44 lbf·ft)
Rear upper/lower engine mounting nut	54 N·m (5.5 kgf·m, 40 lbf·ft)
Pillion step bracket bolt	45 N·m (4.6 kgf·m, 33 lbf·ft)
Gearshift pedal pinch bolt	12 N·m (1.2 kgf·m, 9 lbf·ft)

ENGINE REMOVAL/INSTALLATION

DRIVE SPROCKET

REMOVAL

Raise the rear wheel off the ground by placing a work stand or box under the frame.

Disconnect the brake rod by removing the adjusting nut, and remove the spring and joint pin.

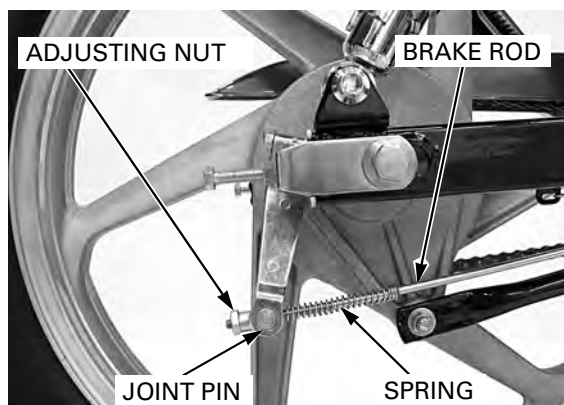

Loosen the drive chain by loosening the rear axle nut, lock nut and the drive chain adjusting bolt.

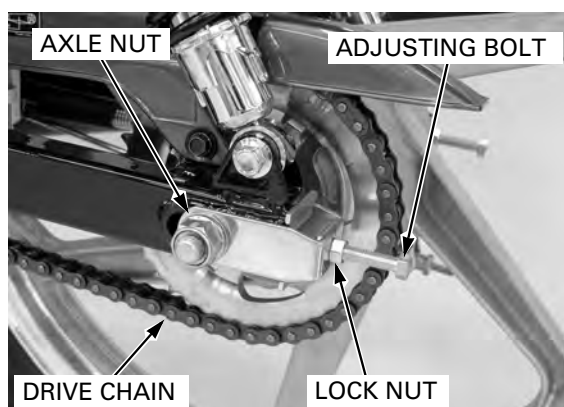

Remove the gearshift pedal pinch bolt and the gearshift pedal.

Remove the two bolts, washers, left crankcase rear cover, grommet, collar and the drive chain guide.

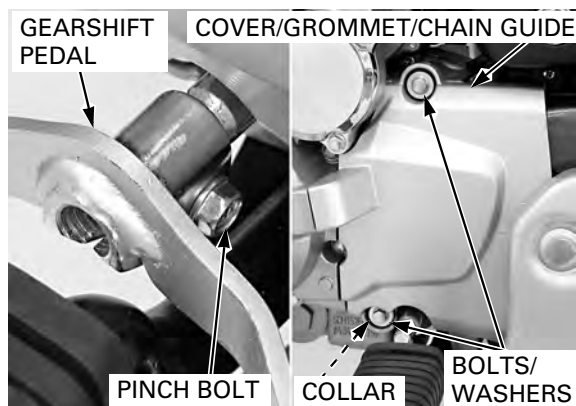

Remove the two fixing plate mounting bolts. Turn the fixing plate until the slots of the fixing plate and the spline of the countershaft are aligned. Remove the fixing plate, drive chain and the drive sprocket.

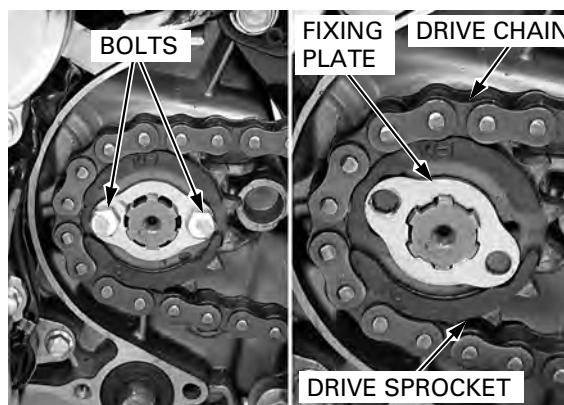

ENGINE REMOVAL/INSTALLATION

INSTALLATION

Install the drive chain to the drive sprocket.
Install the drive sprocket to the countershaft.

Install the fixing plate and turn it until its bolt holes and the bolt holes of the drive sprocket are aligned.

Install and tighten two fixing plate mounting bolts.

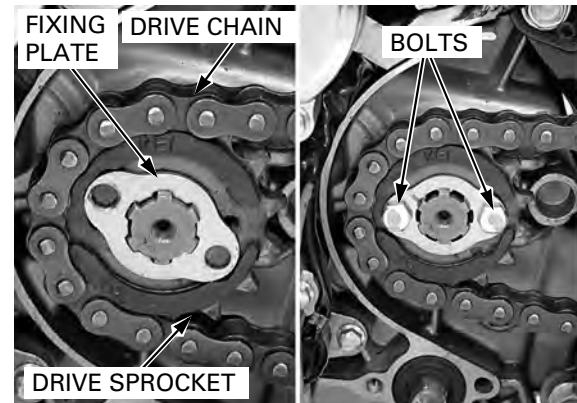

Set the grommet, collar, drive chain guide, washers and bolts to the left crankcase rear cover as shown.

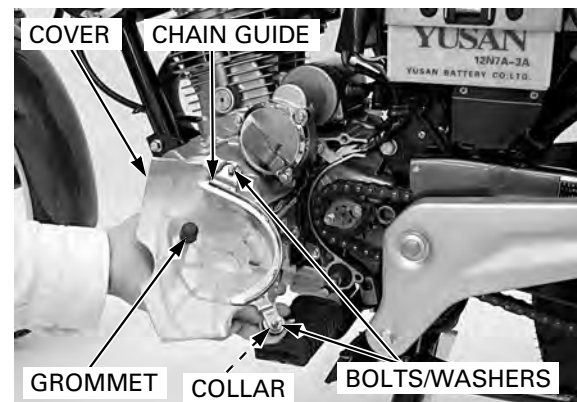

Install the left crankcase rear cover/drive chain guide and tighten the two bolts.

Install the gearshift pedal to the gearshift spindle.
Install and tighten the gearshift pedal pinch bolt to the specified torque.

TORQUE: 12 N·m (1.2 kgf·m, 9 lbf·ft)

Adjust the drive chain (page 3-12).

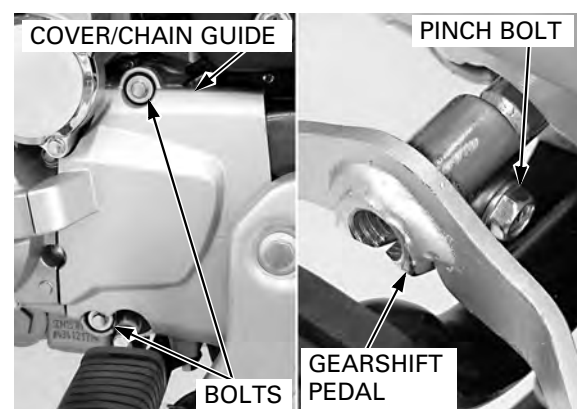

Connect the brake rod by installing the adjusting nut, the spring and joint pin.

Adjust the rear brake (page 3-17).

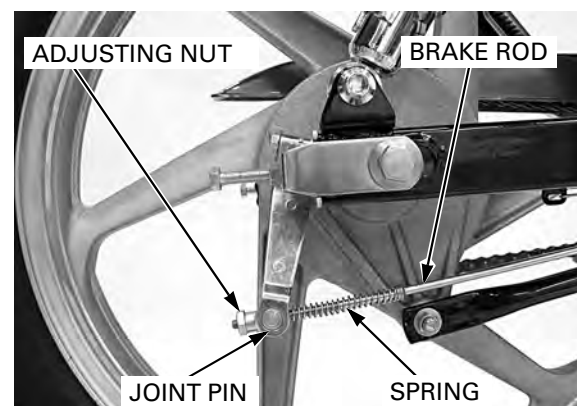

ENGINE REMOVAL/INSTALLATION

ENGINE REMOVAL

Drain the engine oil (page 3-10).

Remove the following:

- Fuel tank (page 2-4)
- Right and left horn covers (page 2-7)
- Muffler (page 2-8)
- Carburetor (page 5-10)
- Drive sprocket (page 6-4)

Disconnect the following:

- Gear position switch 6P connector
- Yellow and Pink alternator wire connectors
- Black/Red exciter coil wire connector
- Green/White and Blue/Yellow ignition pulse generator wire connectors

Unhook the PAIR control valve vacuum hose from the clamp, remove the horn cover stay bolt, right and left horn cover stays.

Disconnect the PAIR control valve vacuum hose from the PAIR control valve.

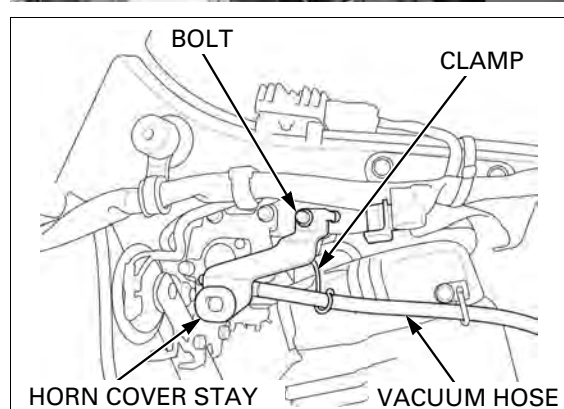
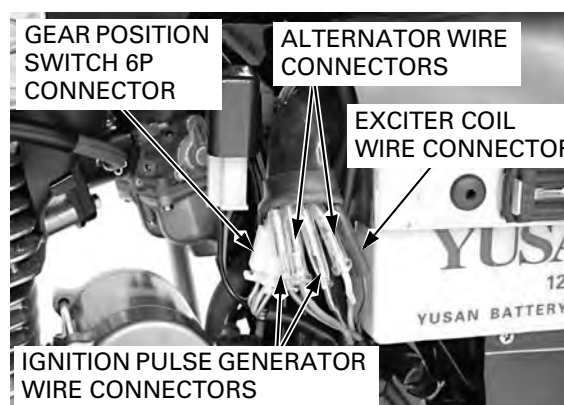

Loosen the clutch cable lock nut and clutch cable adjusting nut.

Release the clutch cable from the stay and disconnect the clutch cable end from the lifter arm.

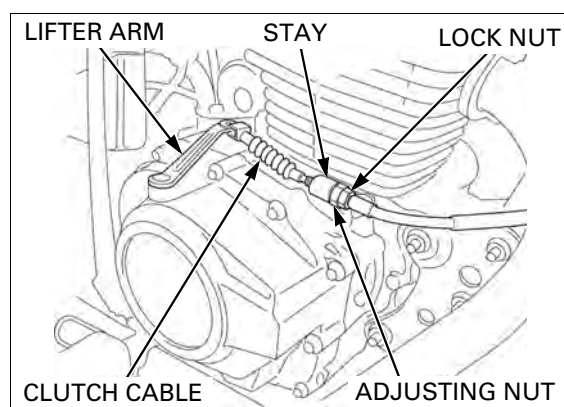

Pull back the rubber cap, remove the terminal nut and disconnect the starter motor wire from the starter motor terminal.

Remove the starter motor rear mounting bolt and disconnect the ground cable from the starter motor.

Disconnect the crankcase breather hose from the crankcase.

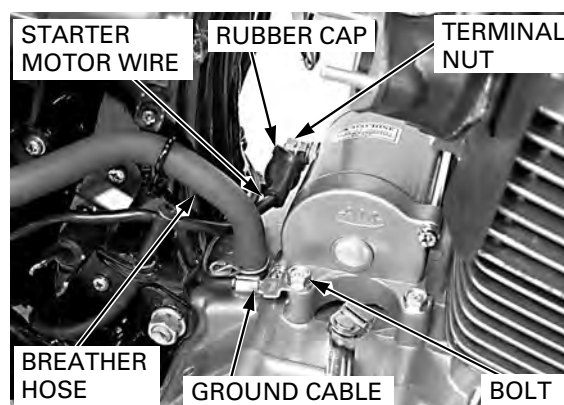

ENGINE REMOVAL/INSTALLATION

Disconnect the spark plug cap from the spark plug and release the spark plug wire from the clamp.

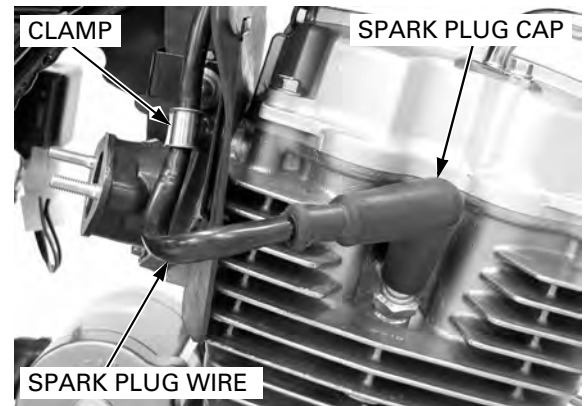

Remove two air supply pipe mounting bolts. Disconnect the air supply pipe and O-ring from the cylinder head cover.

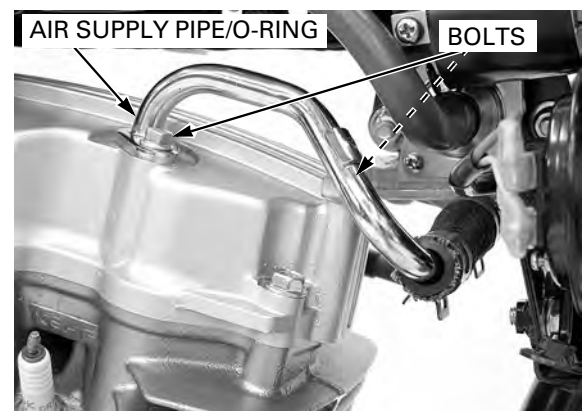

Remove the heat protector mounting bolt and the heat protector.

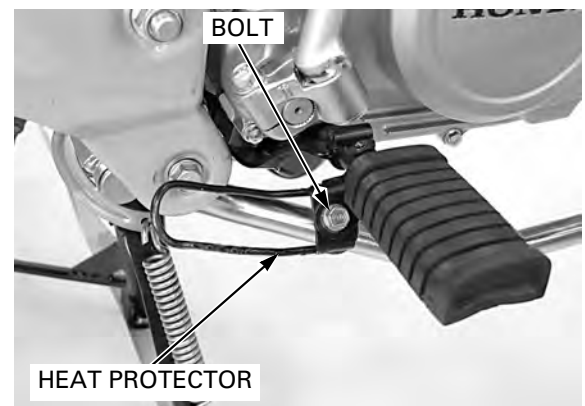

Remove the right pillion step bracket bolt.

Do not remove the swingarm pivot.

Remove the swingarm pivot nut, right pillion step bracket and the washer.

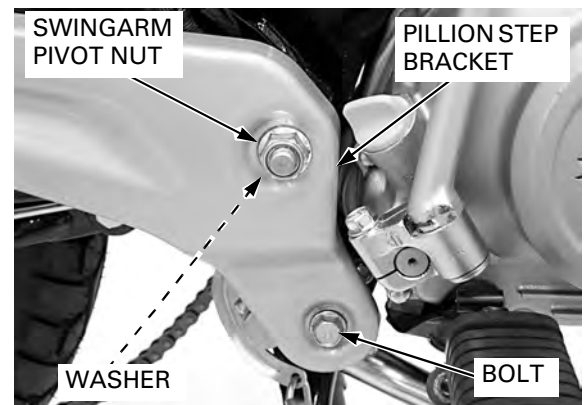

ENGINE REMOVAL/INSTALLATION

Unhook and remove the rear brake pedal return spring.

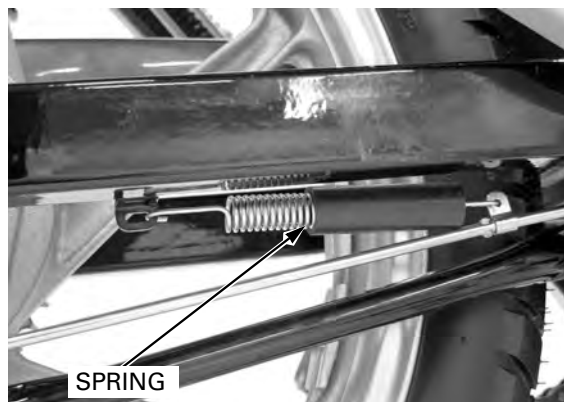

Unhook and the rear brake light switch spring from the rear brake pedal.

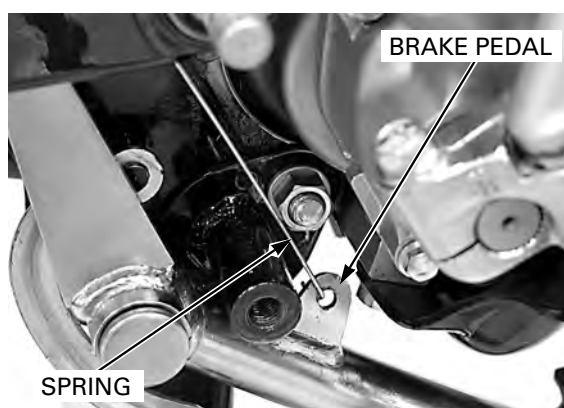

Do not remove the swingarm pivot bolt.

Remove the left pillion step bracket bolt.

Rotate the left pillion step bracket so that the engine rear upper/lower mounting bolts are accessible.

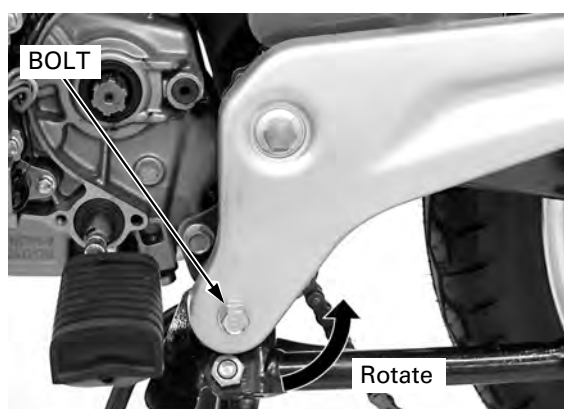

Remove the wire band.

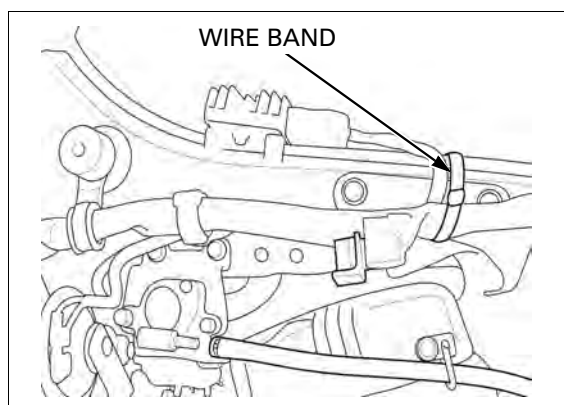

ENGINE REMOVAL/INSTALLATION

Place the floor jack or other adjustable support under the engine.

Remove upper engine hanger mounting bolts/nuts, wind guard rubber/stay and the engine hanger plates.

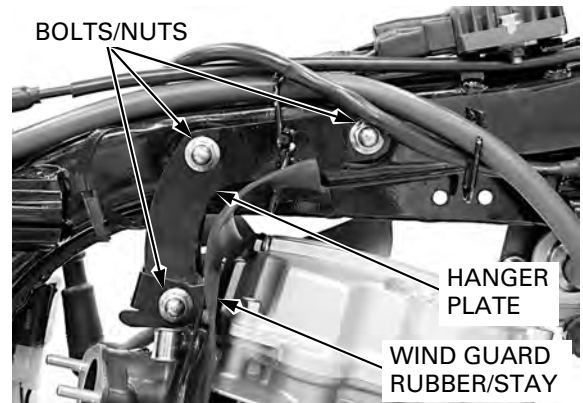

Remove the front engine mounting bracket bolts/nuts and engine hanger bracket.

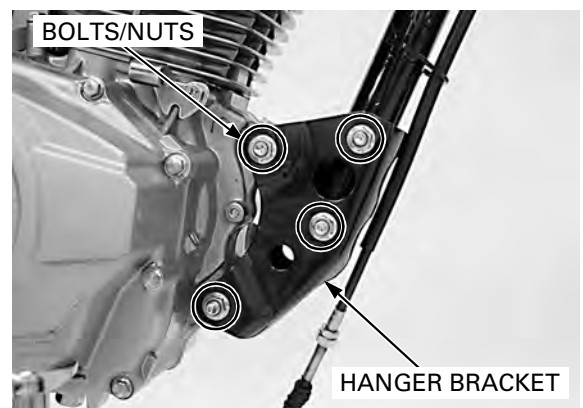

Remove the engine rear upper/lower mounting nuts/washers/bolts.

During engine removal, hold the engine securely and be careful not to damage the frame and engine.

Carefully maneuver the engine and remove it out of the frame.

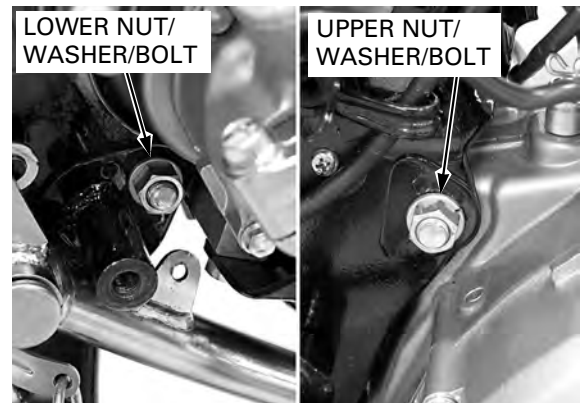

ENGINE REMOVAL/INSTALLATION

ENGINE INSTALLATION

- Use the correct bolts in their proper positions.
- Route the wires and cables properly.

During engine installation, hold the engine securely and be careful not to damage the frame and engine.

Using the floor jack or other adjustable support, carefully place the engine into the frame and maneuver it into place.

Align the mounting bolt holes and install the following fasteners but do not tighten yet:

- Rear upper/lower engine mounting bolts, washers and nuts (10 mm)
- Four front engine mounting bracket bolts, nuts (8 mm) and engine hanger bracket

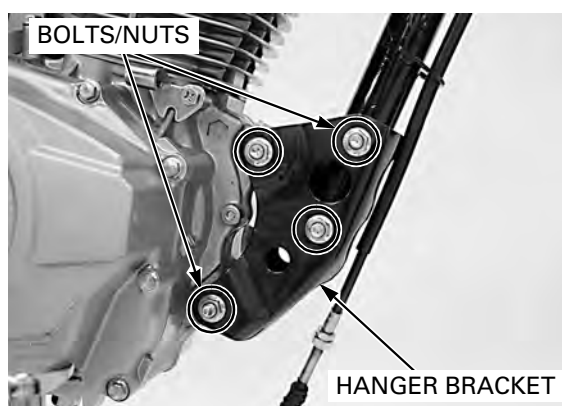
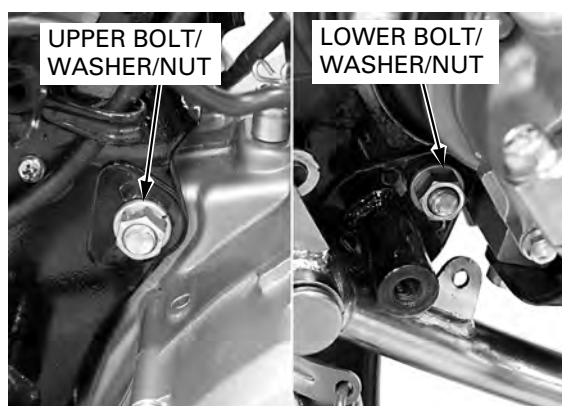

Set the wind guard rubber to the stay and install the wind guard rubber/stay, upper engine hanger plates and three engine hanger plate bolts/nuts.

After installing all the engine mounting fasteners, tighten them to the specified torque.

TORQUE:

1. Rear upper/lower engine mounting nuts
54 N·m (5.5 kgf·m, 40 lbf·ft)
2. Front engine hanger bracket mounting nuts
27 N·m (2.8 kgf·m, 20 lbf·ft)
3. Upper engine hanger plate mounting nuts
27 N·m (2.8 kgf·m, 20 lbf·ft)

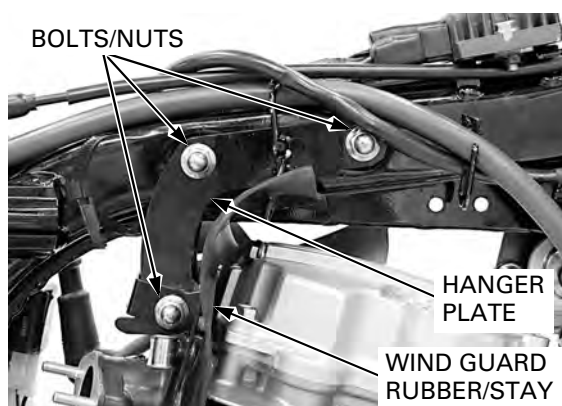

Set the wire band between the right upper engine hanger plate and the frame, secure the main wire harness as shown.

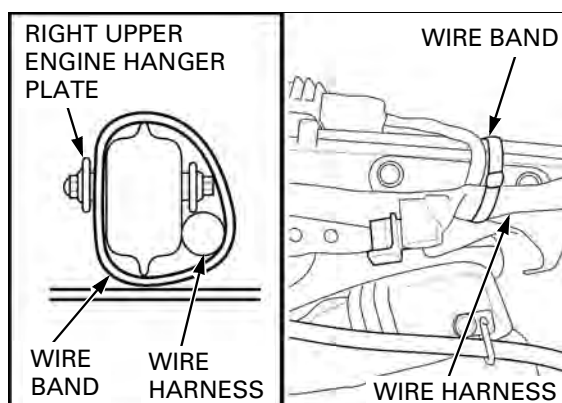

ENGINE REMOVAL/INSTALLATION

Set the left pillion step bracket in its original position and install the left pillion step bracket bolt.

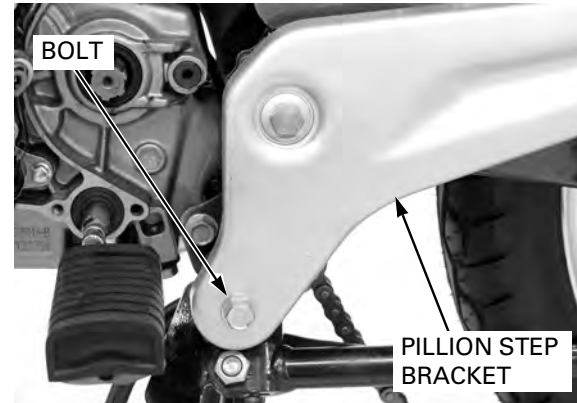

Hook the rear brake light switch spring to the rear brake pedal.

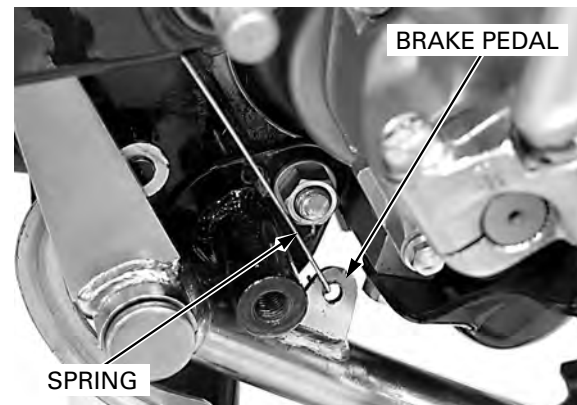

Install the rear brake pedal return spring.

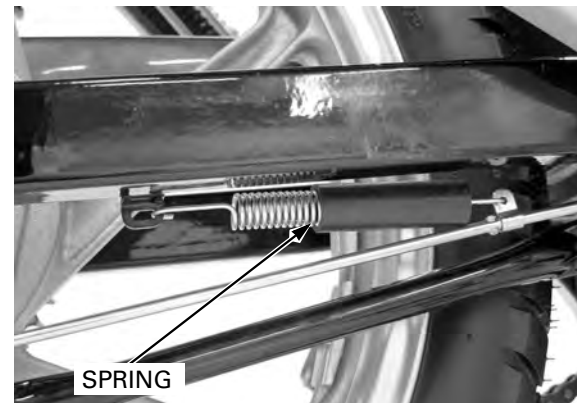

Set the washer to the swingarm pivot and install the right pillion step bracket and the right pillion step bracket bolt.
Install the swingarm pivot nut and tighten it to the specified torque.

TORQUE: 59 N·m (6.0 kgf·m, 44 lbf·ft)

Tighten the right and left pillion step bracket bolts to the specified torque.

TORQUE: 45 N·m (4.6 kgf·m, 33 lbf·ft)

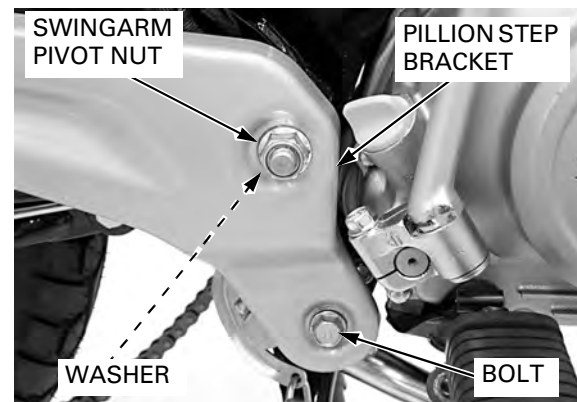

ENGINE REMOVAL/INSTALLATION

Install the heat protector and the heat protector mounting bolt and tighten it.

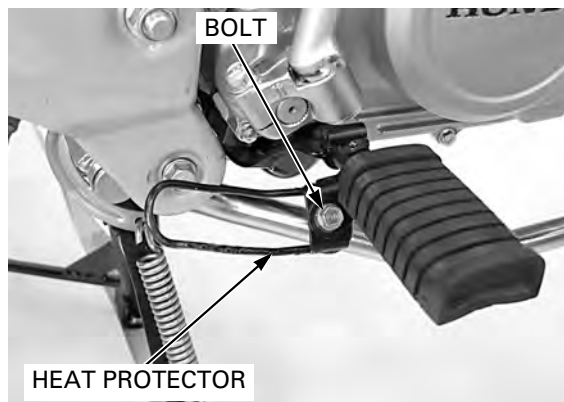

Coat new O-ring with engine oil and install it to the air supply pipe.



Install the air supply pipe/O-ring to the cylinder head and tighten two bolts.

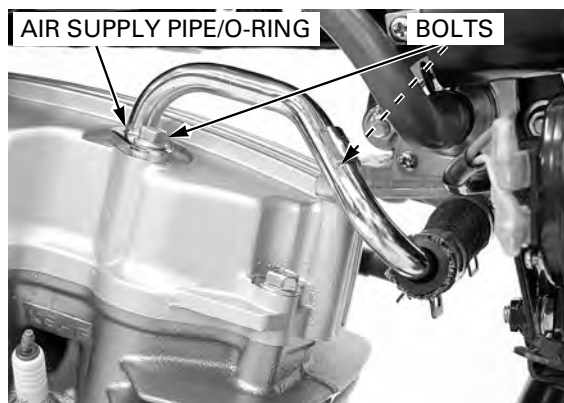

Set the spark plug wire to the clamp.
Connect the spark plug cap to the spark plug.

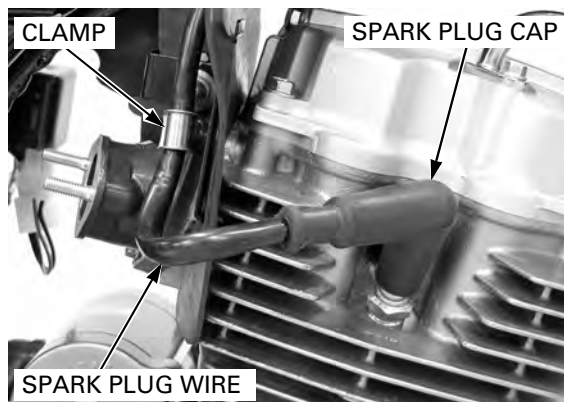

ENGINE REMOVAL/INSTALLATION

Connect the crankcase breather hose. Install the starter motor rear mounting bolt with the ground cable, and tighten the bolt securely. Install the starter motor wire and terminal nut onto the terminal and tighten the nut securely. Install the rubber cap over the motor terminal properly.

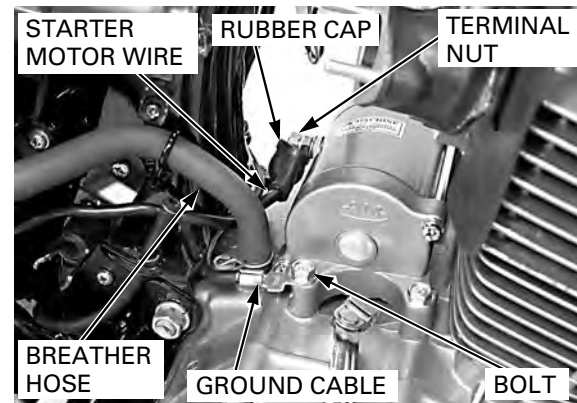

Connect the clutch cable end to the lifter arm and set the clutch cable to the stay.

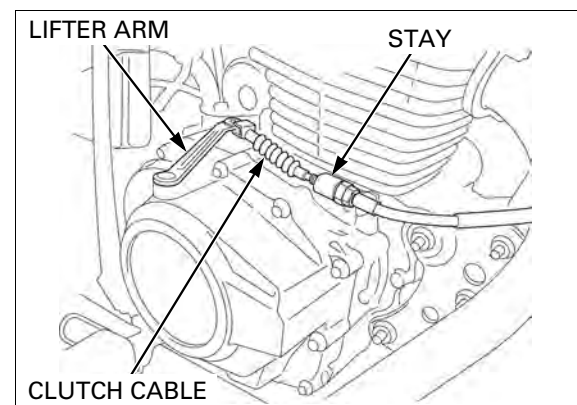

Connect the PAIR control valve vacuum hose to the PAIR control valve.

Set the right and left horn cover stays to the frame by inserting the tabs of the horn cover stays into the hole of the frame. Install and tighten the horn cover stay mounting bolt.

Set the PAIR control valve vacuum hose to the clamp.

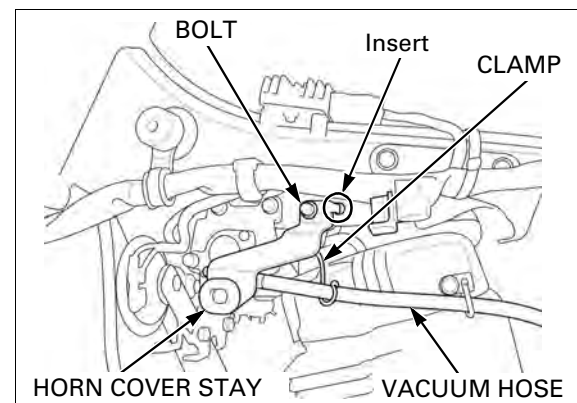

Connect the following:

- Gear position switch 6P connector
- Yellow and Pink alternator wire connectors
- Black/Red exciter coil wire connector
- Green/White and Blue/Yellow ignition pulse generator wire connectors

Install the following:

- Drive sprocket (page 6-5)
- Carburetor (page 5-19)
- Muffler (page 2-9)
- Right and left horn covers (page 2-7)
- Fuel tank (page 2-4)

Adjust the following:

- Clutch cable (page 3-18)
- Drive chain (page 3-12)
- Rear brake (page 3-17)

Check the brake light operation.

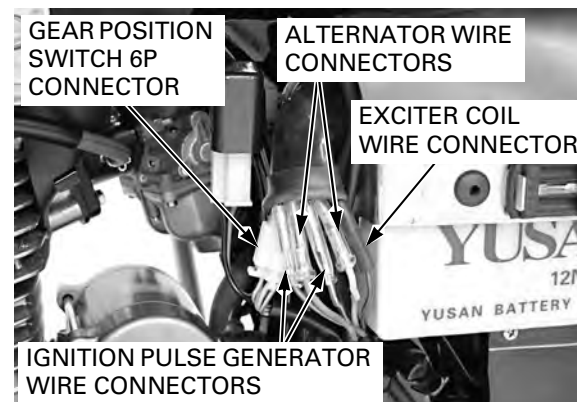

MEMO

7. CYLINDER HEAD/VALVES

SYSTEM COMPONENTS	7-2	CYLINDER HEAD COVER.....	7-7
SERVICE INFORMATION	7-3	ROCKER ARM HOLDER	7-10
TROUBLESHOOTING	7-5	CYLINDER HEAD	7-12
CYLINDER COMPRESSION.....	7-6		

CYLINDER HEAD/VALVES
SYSTEM COMPONENTS

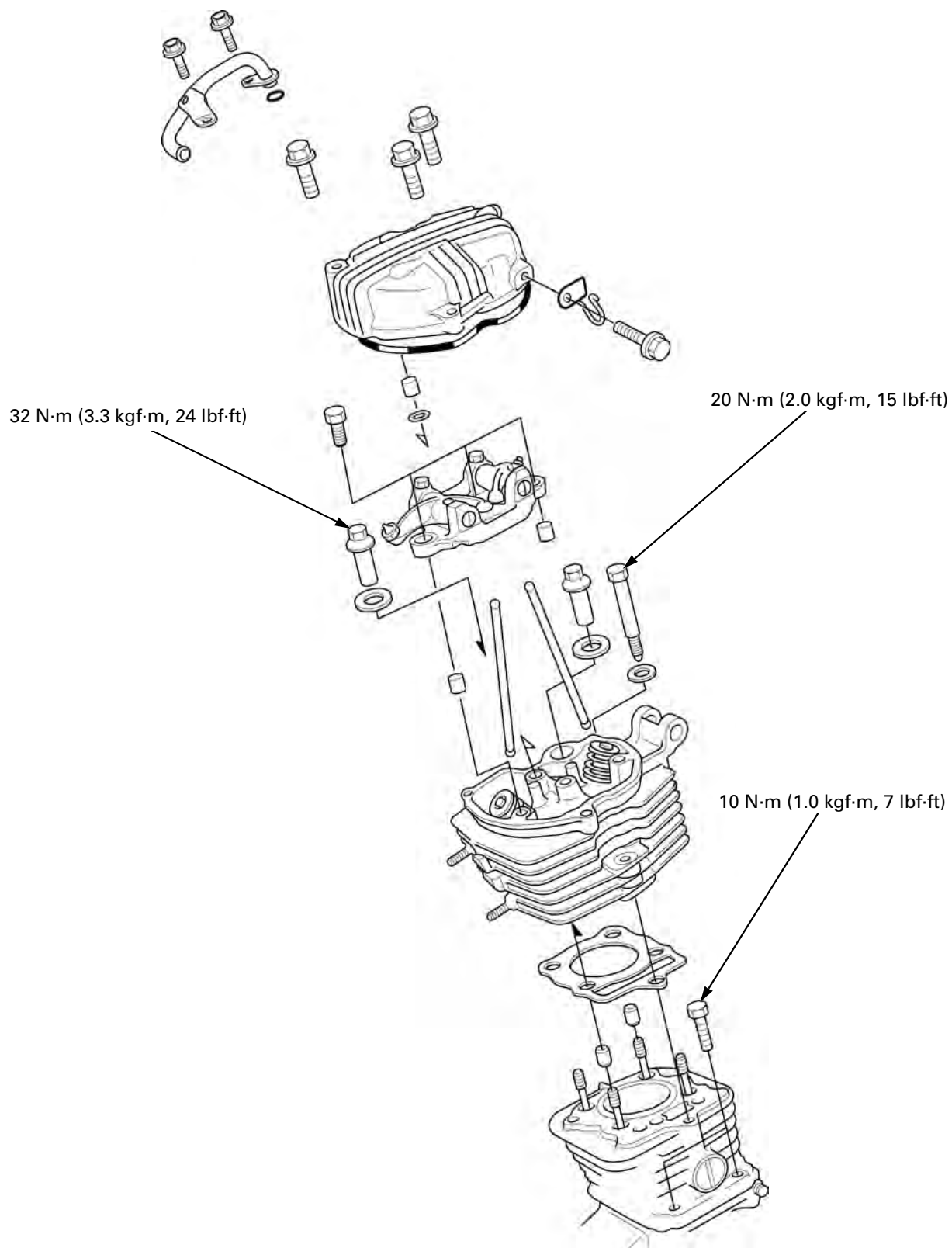

SERVICE INFORMATION

GENERAL

- This section covers service of the cylinder head, valves and, rocker arms.
- The rocker arm services can be done with the engine installed on the frame. To service the cylinder head parts, the engine must be removed from the frame.
- Be careful not to damage the mating surfaces when removing the cylinder head cover and cylinder head.
- When disassembling, mark and store the disassembled parts to ensure that they are reinstalled in their original locations.
- Clean all disassembled parts with cleaning solvent and dry them by blowing them off with compressed air before inspection.
- Rocker arm lubricating oil is fed through oil passage in the cylinder head. Clean the oil passage before assembling cylinder head.

SPECIFICATIONS

Unit: mm (in)







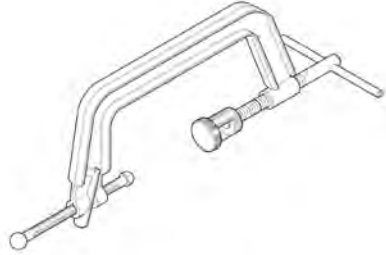
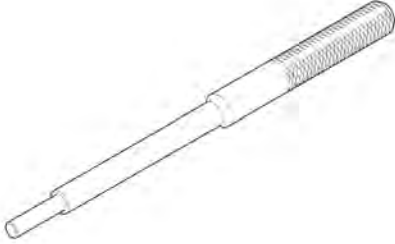

ITEM			STANDARD	SERVICE LIMIT
Cylinder compression			1,226 kPa (12.5 kgf/cm ² , 178 psi) at 450 min ⁻¹ (rpm)	–
Valve clearance		IN/EX	0.08 ± 0.02 (0.003 ± 0.001)	–
Valve, valve guide	Valve stem O.D.	IN	5.450 – 5.465 (0.2146 – 0.2152)	5.42 (0.213)
		EX	5.430 – 5.445 (0.2138 – 0.2144)	5.40 (0.213)
	Valve guide I.D.	IN/EX	5.475 – 5.485 (0.2156 – 0.2159)	5.50 (0.217)
	Stem-to-guide clearance	IN	0.010 – 0.035 (0.0004 – 0.0014)	0.12 (0.005)
		EX	0.030 – 0.055 (0.0012 – 0.0022)	0.14 (0.006)
Valve seat width	IN/EX	1.2 – 1.5 (0.05 – 0.06)	2.0 (0.08)	
Valve spring free length	Inner	IN/EX	33.5 (1.32)	30.0 (1.18)
	Outer	IN/EX	40.9 (1.61)	39.8 (1.57)
Push rod length			141.15 – 141.45 (5.557 – 5.569)	141.0 (5.55)
Rocker arm	Arm I.D.	IN/EX	12.000 – 12.018 (0.4724 – 0.4731)	12.05 (0.474)
	Shaft O.D.	IN/EX	11.977 – 11.995 (0.4715 – 0.4722)	11.95 (0.470)
	Arm holder I.D	IN/EX	12.000 – 12.027 (0.4724 – 0.4735)	12.05 (0.474)
	Arm-to-shaft clearance	IN/EX	0.005 – 0.041 (0.0002 – 0.0016)	0.10 (0.004)
Cylinder head warpage			–	0.05 (0.002)

TORQUE VALUES

Cylinder head nut	32 N·m (3.3 kgf·m, 24 lbf·ft)	Apply oil to the threads and seating surface.
Cylinder head bolt	20 N·m (2.0 kgf·m, 15 lbf·ft)	
Cylinder bolt	10 N·m (1.0 kgf·m, 7 lbf·ft)	
Rocker arm shaft bolt	12 N·m (1.2 kgf·m, 9 lbf·ft)	
Timing hole cap	6 N·m (0.6 kgf·m, 4.4 lbf·ft)	
Crankshaft hole cap	8 N·m (0.8 kgf·m, 5.9 lbf·ft)	

CYLINDER HEAD/VALVES

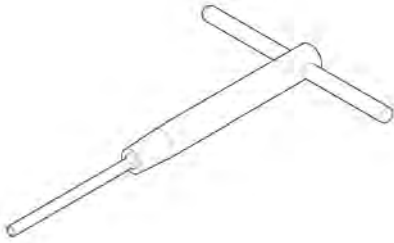
TOOLS

<p>Valve spring compressor 07757-0010000</p> 	<p>Valve guide driver, 5.35 mm 07742-0010100</p> 	<p>Valve seat cutter, 24.5 mm (45° EX) 07780-0010100</p> 
<p>Valve seat cutter, 33 mm (45° IN) 07780-0010800</p> 	<p>Flat cutter, 25 mm (32° EX) 07780-0012000</p> 	<p>Flat cutter, 33 mm (32° IN) 07780-0012900</p> 
<p>Interior cutter, 30 mm (60° IN/EX) 07780-0014000</p> 	<p>Cutter holder, 5.5 mm 07781-0010101</p> 	<p>Valve guide reamer, 5.485 mm 07984-0980001</p> 

TROUBLESHOOTING

- Engine top-end problems usually affect engine performance. These can be diagnosed by a compression or leak down test, or by tracing engine noises to the top-end with a sounding rod stethoscope.
- If the performance is poor at low speeds, check the crankcase breather tube for white smoke. If the tube is smoky, check a seized piston ring (page 8-10).

Compression too low, hard starting or poor performance at low speed

- Valves
 - Incorrect valve adjustment
 - Burned or bent valves
 - Incorrect valve timing
 - Broken valve spring
 - Uneven valve seating
 - Valve stuck open
- Cylinder head
 - Leaking or damaged cylinder head gasket
 - Warped or cracked cylinder head
 - Loose spark plug
- Worn cylinder (page 8-4)
- Worn piston or piston rings (page 8-10)

Compression too high, overheating or knocking

- Excessive carbon build-up in cylinder head or on top of piston
- Faulty ignition timing.

Excessive smoke

- Worn valve stem or valve guide
- Damaged stem seal
- Faulty cylinder (page 8-4)
- Faulty piston or piston rings (page 8-10)

Excessive noise

- Cylinder head
 - Incorrect valve adjustment
 - Sticking valve or broken valve spring
 - Worn or damaged push rod
 - Worn rocker arm and/or shaft
- Faulty cylinder (page 8-4)
- Faulty piston or piston rings (page 8-10)

Rough idle

- Low cylinder compression
- Intake air leak

CYLINDER HEAD/VALVES

CYLINDER COMPRESSION

Warm up the engine to normal operating temperature.

Stop the engine.

Disconnect the spark plug cap and remove the spark plug.

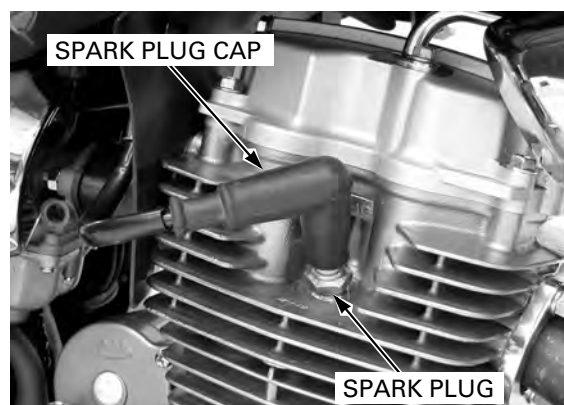

Install the compression gauge into the spark plug hole.

Shift the transmission in neutral.

Push the choke lever down fully (open).

Open the throttle all the way and crank the engine with the kickstarter or starter motor until the gauge reading stops rising.

The maximum reading is usually reached within 4 – 7 seconds.

COMPRESSION PRESSURE:

1,226 kPa (12.5 kgf/cm², 178 psi) at 450 min⁻¹(rpm)

If compression is high, it indicates that carbon deposits have accumulated on the combustion chamber and/or the piston crown.

If compression is low, pour 3 – 5 cc (0.1 – 0.2 oz) of clean engine oil into the cylinder through the spark plug hole and recheck the compression.

If the compression increases from the previous value, check the cylinder, piston and piston rings.

- Leaking cylinder head gasket
- Worn piston ring
- Worn cylinder and piston

If compression is the same as the previous value, check the valves for leakage.

To avoid discharging the battery, do not operate the starter motor for more than seven seconds.



CYLINDER HEAD COVER

REMOVAL

Remove the horn cover stays (page 6-6).

Remove the two air supply pipe mounting bolts and disconnect the air supply pipe from the cylinder head cover.



Remove the three cylinder head cover bolts.

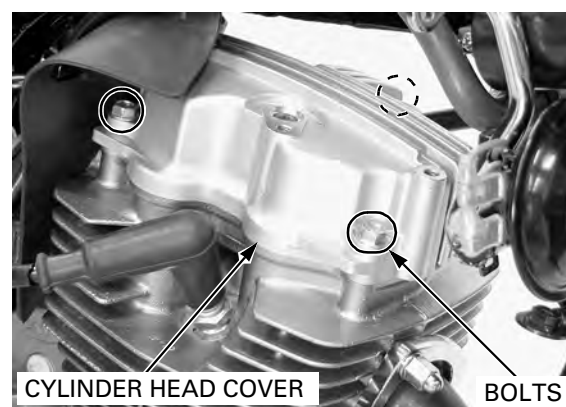

Remove the timing hole cap and crankshaft hole cap.

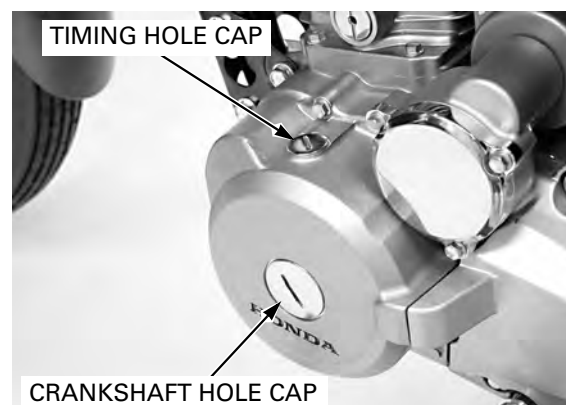

Rotate the crankshaft counterclockwise and align the index line of the "T" mark on the flywheel with the index notch on the left crankcase cover. Make sure that the piston is at TDC (Top Dead Center) on the compression stroke. (The rocker arms should be loose.)

If the rocker arms are tight, rotate the crankshaft counterclockwise 360°(1 full turn) and realign the index line of the "T" mark with the index notch again.

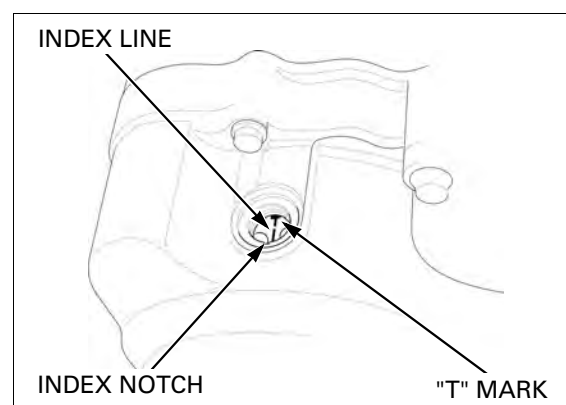

CYLINDER HEAD/VALVES

Rotate the crankshaft until the intake rocker arm is at the lowest position.
Remove the cylinder head cover from the right side of the frame.

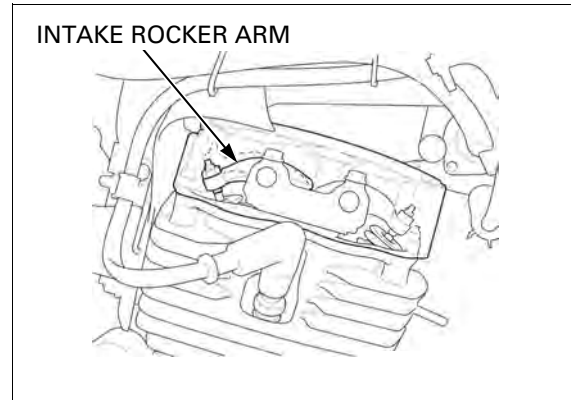

Remove the O-ring and joint pin.
Remove the cylinder head cover packing.

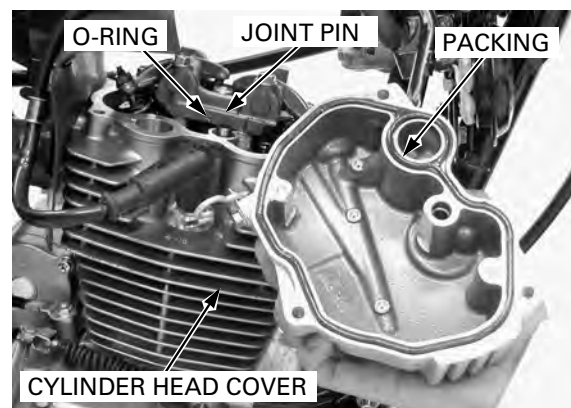

INSTALLATION

Coat new O-ring with engine oil.
Install a new O-ring to the joint pin and install the joint pin to the cylinder head.

Install a new packing into the cylinder head cover groove.

Rotate the crankshaft until the intake rocker arm is at the lowest position (page 7-8).

Install the cylinder head cover from the right side of the frame.

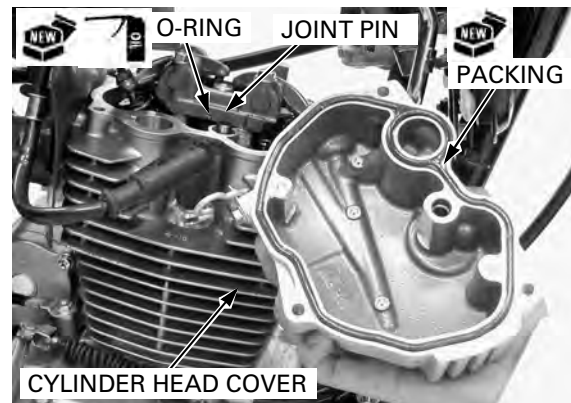

Install and tighten the bolts to the cylinder head cover.

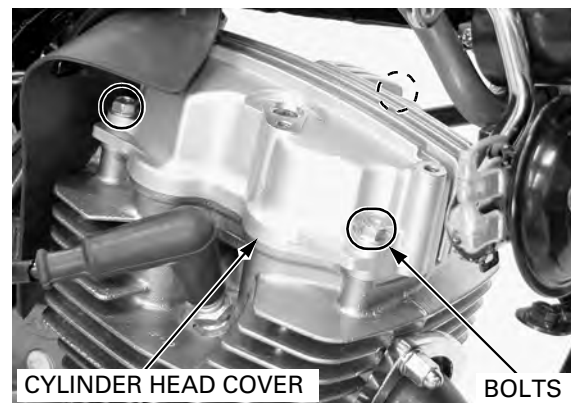

CYLINDER HEAD/VALVES

Coat new O-ring with engine oil and set the air supply pipe to the cylinder head.

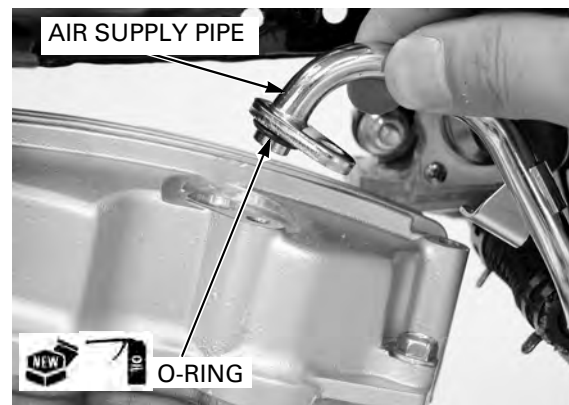

Install the air supply pipe mounting bolts and tighten them.



Apply engine oil to the new O-rings. Install the O-rings to the timing hole cap and crankshaft hole cap.

Install and tighten the timing hole cap to the specified torque.

TORQUE: 6 N·m (0.6 kgf·m, 4.4 lbf·ft)

Install and tighten the crankshaft hole cap to the specified torque.

TORQUE: 8 N·m (0.8 kgf·m, 5.9 lbf·ft)

Install the horn cover stays (page 6-13).

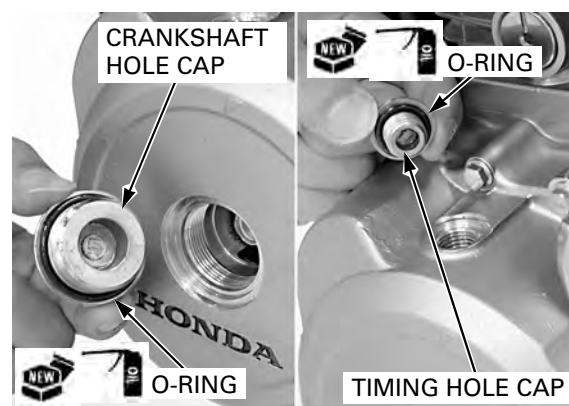

CYLINDER HEAD/VALVES

ROCKER ARM HOLDER

REMOVAL

Remove the cylinder head cover (page 7-7).

Remove the rocker arm holder bolts and rocker arm holder assembly.

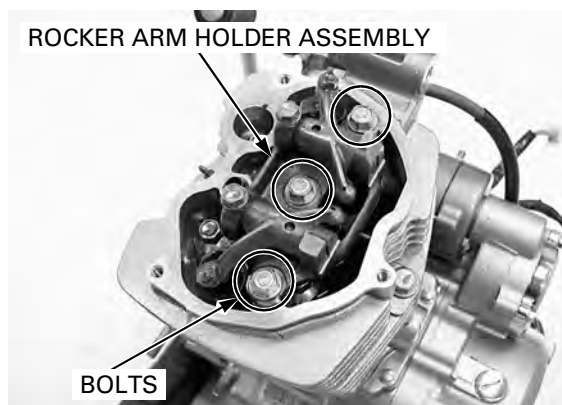

Do not drop the dowel pins into the crankcase from the cylinder head.

Remove the dowel pins.

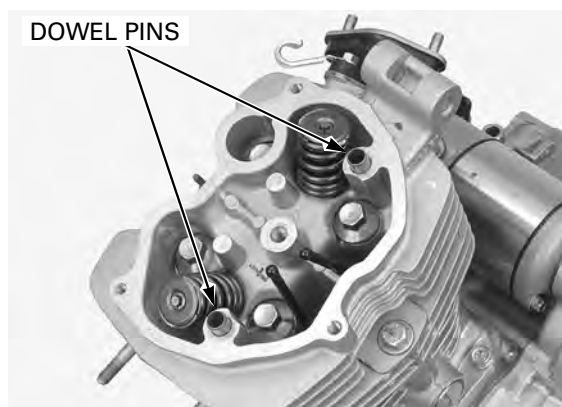

DISASSEMBLY/INSPECTION

Remove the rocker arm shaft bolts and rocker arm shafts.

Remove the rocker arms.

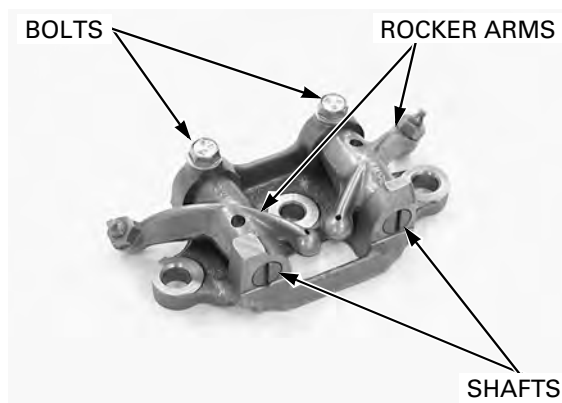

Inspect the rocker arms and shafts for wear or damage.

Measure the O.D. of each rocker arm shaft.

SERVICE LIMIT: 11.95 mm (0.470 in)

Measure the I.D. of each rocker arm.

SERVICE LIMIT: 12.05 mm (0.474 in)

Subtract each rocker arm shaft O.D. from the corresponding rocker arm I.D. to obtain the rocker arm-to-arm shaft clearance.

SERVICE LIMIT: 0.10 mm (0.004 in)

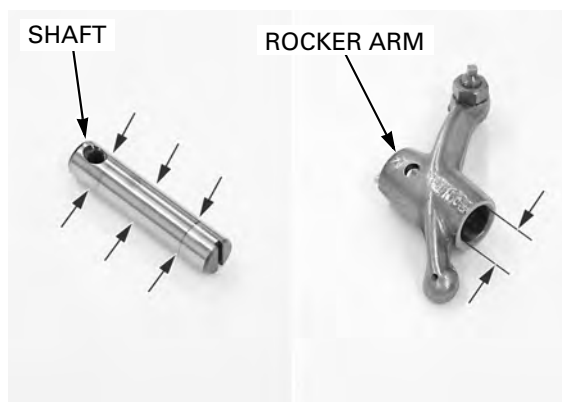

CYLINDER HEAD/VALVES

Measure the I.D. of each rocker arm holder.

SERVICE LIMIT: 12.05 mm (0.474 in)

ROCKER ARM
HOLDER

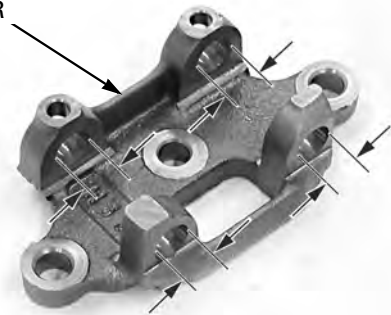

ASSEMBLY

Apply clean engine oil to the rocker arms and shafts sliding surfaces.

Set and hold the rocker arm on the holder, then install the shaft.

Turn the shaft with a screwdriver to align the holder hole with the shaft hole.

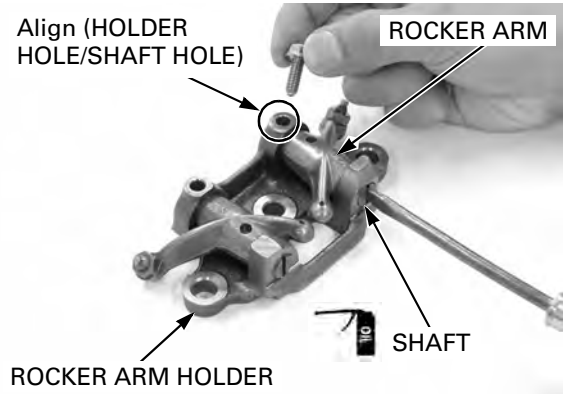

Install and tighten the rocker arm shaft bolts to the specified torque.

TORQUE: 12 N·m (1.2 kgf·m, 9 lbf·ft)

BOLTS



INSTALLATION

The push rods are interchangeable.

Apply clean engine oil to the ends of the push rods. Install the dowel pins.

DOWEL PINS

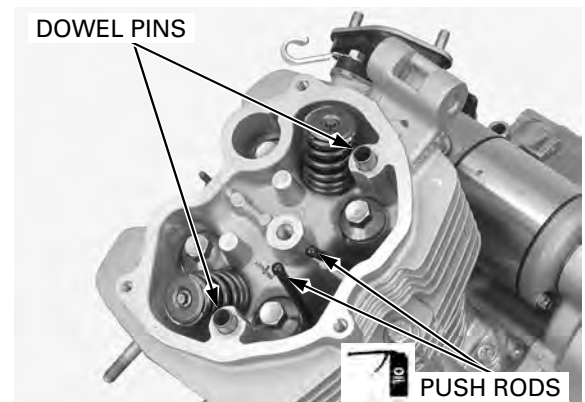

CYLINDER HEAD/VALVES

Install the rocker arm holder assembly.
Install the rocker arm holder bolts and tighten them.
Check and adjust the valve clearance (page 3-8).

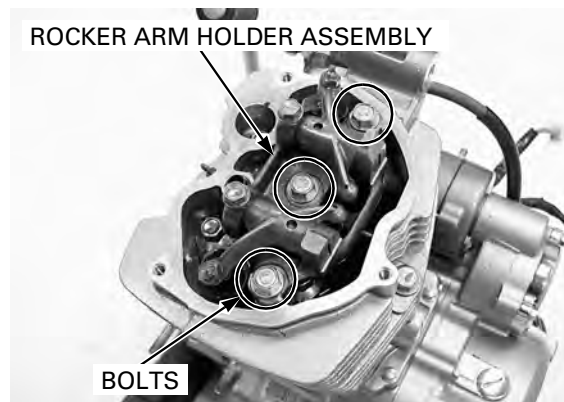

CYLINDER HEAD

REMOVAL

Remove the following:

- Engine (page 6-6)
- Cylinder head cover (page 7-7)
- Rocker arm holder (page 7-10)

Remove the push rods.

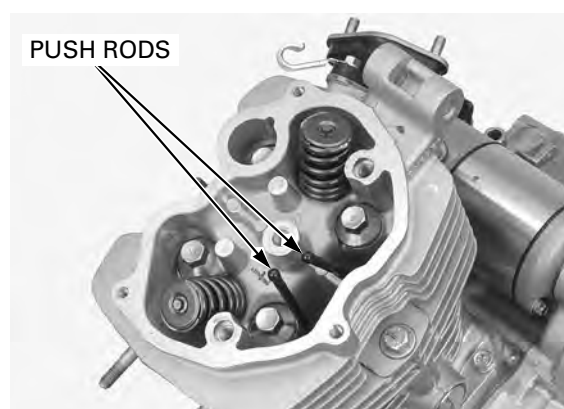

Loosen the cylinder bolts.

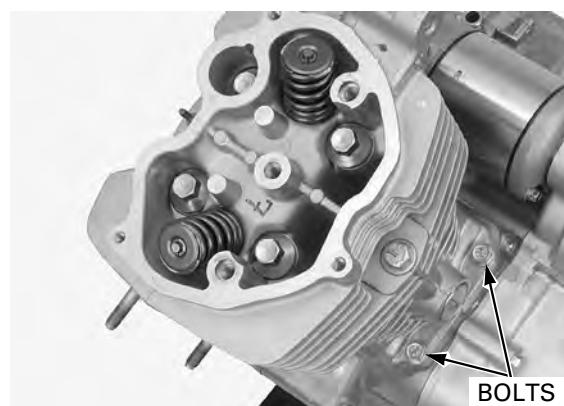

Remove the left side cylinder head bolt and sealing washer.

Remove the cylinder head nuts, washers and cylinder head.

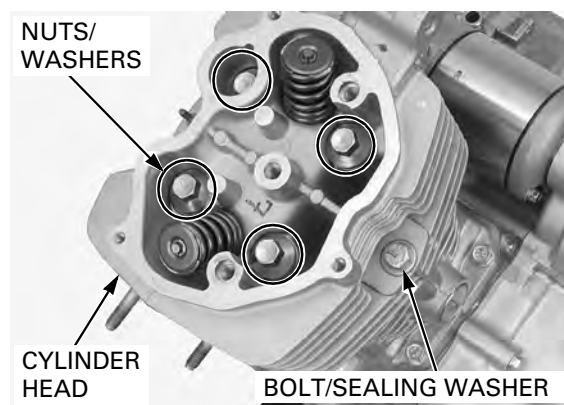

CYLINDER HEAD/VALVES

Remove the dowel pins and gasket.

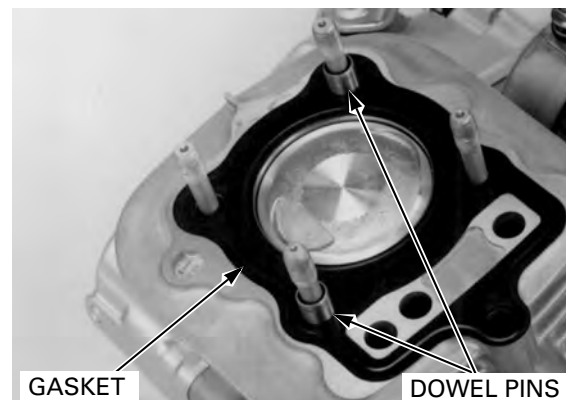

DISASSEMBLY

To prevent loss of tension, do not compress the valve spring more than necessary to remove the cotters.

While compressing the valve spring with a valve spring compressor, remove the valve cotters.

TOOL:
Valve spring compressor **07757-0010000**



Mark all disassembled parts to ensure correct reassembly.

Loosen the valve spring compressor and remove the following:

- Spring retainers
- Valve springs
- Spring seats
- Intake and exhaust valves
- Intake and exhaust valve stem seals

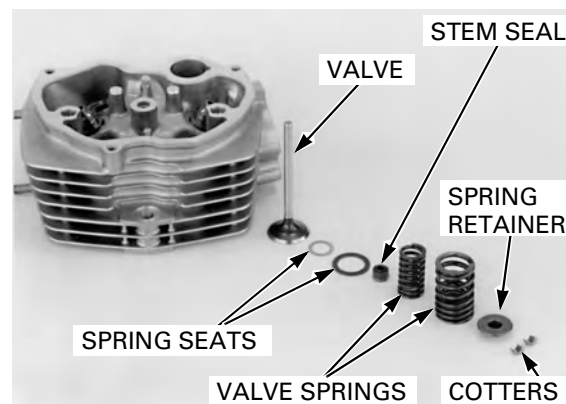

INSPECTION

Valve spring

Measure the valve spring free length.

SERVICE LIMITS: INNER: 30.0 mm (1.18 in)
OUTER: 39.8 mm (1.57 in)



CYLINDER HEAD/VALVES

Push rod

Check the push rods for bending.
Measure the push rods length.

SERVICE LIMIT: 141.0 mm (5.55 in)

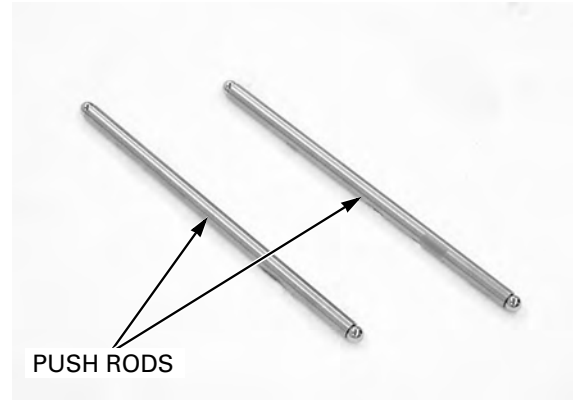

Cylinder head

Remove the carbon deposits from the combustion chamber.

Be careful not to damage the gasket surface.

Clean off any gasket materials from the cylinder head surface.

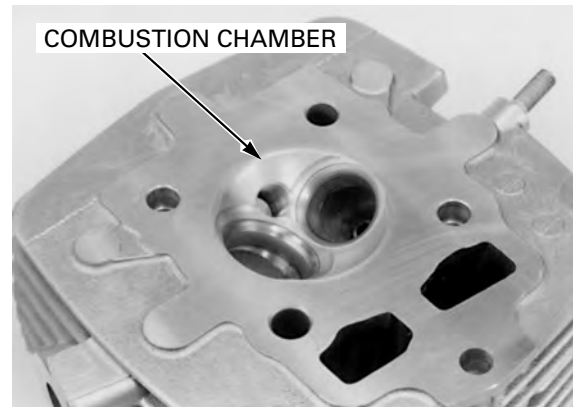

Check the spark plug hole and valve area for cracks.
Check the cylinder head for warpage with a straight edge and a feeler gauge.

SERVICE LIMIT: 0.05 mm (0.002 in)

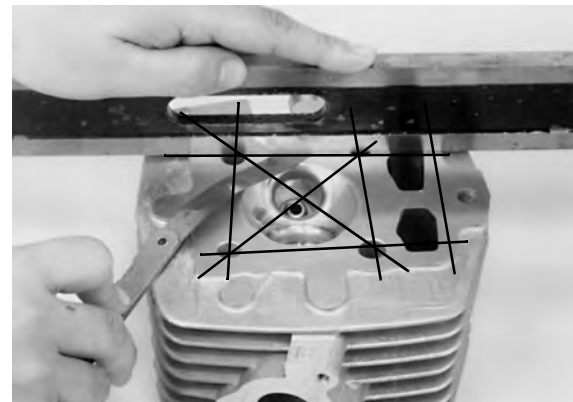

Valve

Inspect the valve for trueness, burning, scratches or abnormal stem wear.
Measure the valve stem O.D.

SERVICE LIMITS: IN: 5.42 mm (0.213 in)
EX: 5.40 mm (0.213 in)

Insert each valve into the valve guide and check the valve movement in the guide.

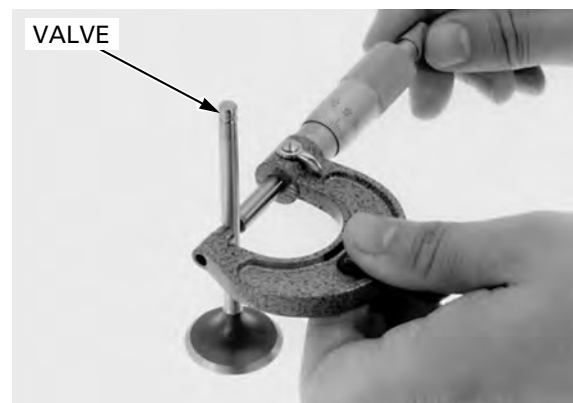

CYLINDER HEAD/VALVES

Always rotate the reamer clockwise, never counter-clockwise.

Ream the guides to remove any carbon build-up before measuring the guide.

TOOL:
Valve guide reamer, 5.485 mm 07984-0980001

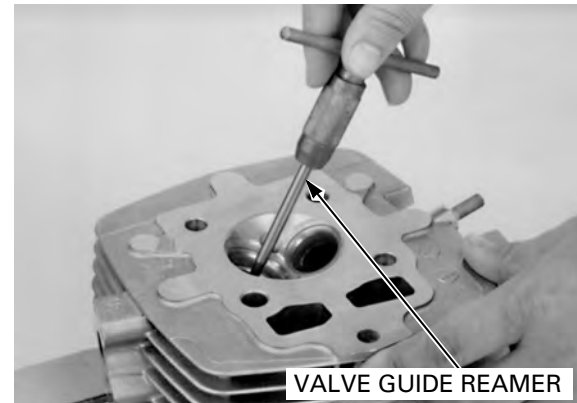

Measure each valve guide I.D. and record it.

SERVICE LIMIT: IN/EX: 5.50 mm (0.217 in)

Subtract each valve stem O.D. from the corresponding guide I.D. to obtain the stem-to-guide clearance.

SERVICE LIMITS: IN: 0.12 mm (0.005 in)
EX: 0.14 mm (0.006 in)

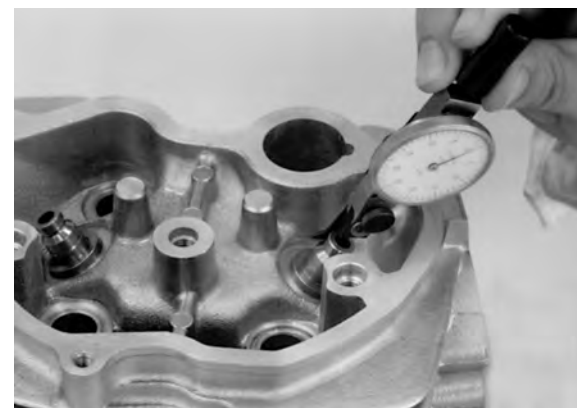

Inspect and reface the valve seats whenever the valve guides are replaced (page 7-16).

If the stem-to-guide clearance exceeds the service limit, determine if a new guide with standard dimensions would bring the clearance within tolerance. If so, replace any guides as necessary and ream to fit.

If the stem-to-guide clearance exceeds the service limit with a new guide, also replace the valve.

VALVE GUIDE REPLACEMENT

Chill the replacement valve guides in the freezer of a refrigerator for about an hour.

Be sure to wear heavy gloves to avoid burns when handling the heated cylinder head.

Heat the cylinder head to 100°C (212°F) with a hot plate or oven.

Do not heat the cylinder head beyond 150°C (300°F). Use temperature indicator sticks, available from welding supply stores, to be sure that the cylinder head is heated to the proper temperature.

Support the cylinder head and drive out the valve guide from the combustion chamber side of the cylinder head.

TOOL:
Valve guide driver, 5.35 mm 07742-0010100

Apply engine oil to the new O-rings.

Take out the new valve guides from the freezer.

Install the O-rings to the new valve guides.

Reface the valve seat whenever new valve guides are installed.

Keep driving in the valve guides from the top of the cylinder head until it is seated.

TOOL:
Valve guide driver, 5.35 mm 07742-0010100

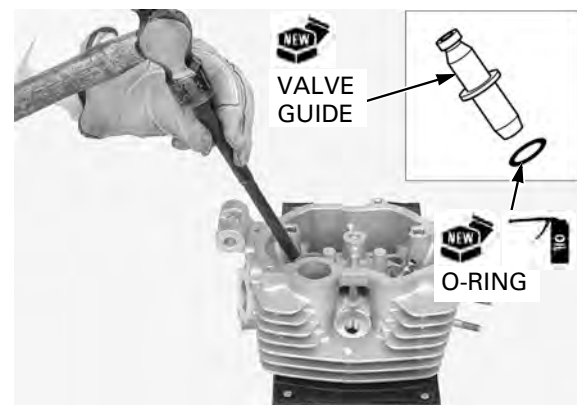
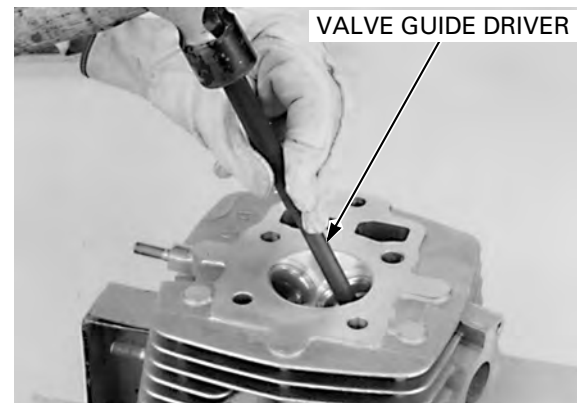

CYLINDER HEAD/VALVES

Use cutting oil on the reamer during this operation. Take care not to tilt or lean the reamer in the guide while reaming.

After driving in the valve guide, insert the valve guide reamer from the combustion chamber side of the cylinder head and always rotate the reamer clockwise.

TOOL:
Valve guide reamer, 5.485 mm 07984-0980001

Clean the cylinder head thoroughly to remove any metal particles after reaming and reface the valve seat.

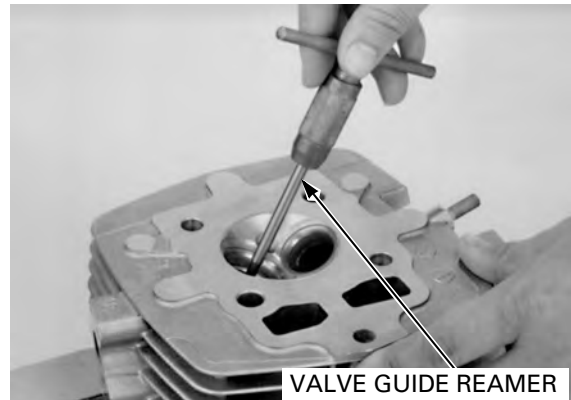

VALVE SEAT INSPECTION

Clean the intake and exhaust valves thoroughly to remove any carbon deposit.

Apply Prussian Blue light coating to the valve seats. Lap the valves and seats with a rubber hose or another hand-lapping tool.

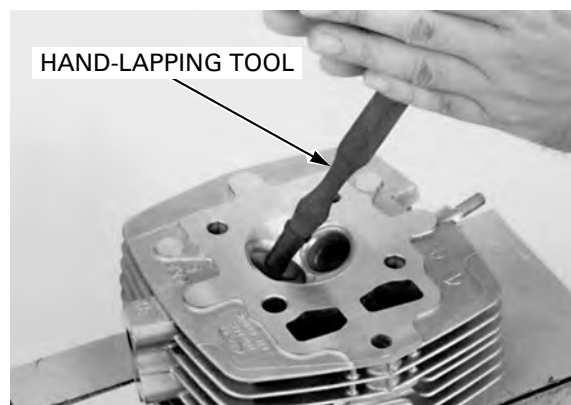

Remove the valve and inspect the valve seat face. The valve seat contact should be within the specified width and even all around the circumference.

STANDARD: 1.2 – 1.5 mm (0.05 – 0.06 in)
SERVICE LIMIT: 2.0 mm (0.08 in)

If the valve seat width is not within specification, reface the valve seat.

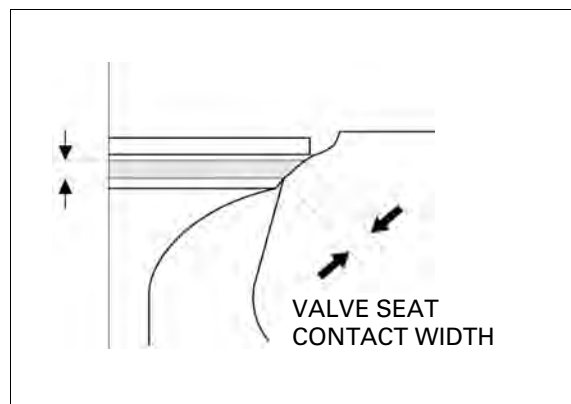

Inspect the valve seat face for:

- Uneven seat width:
 - Bent or collapsed valve stem; Replace the valve and reface the valve seat.
- Damaged face:
 - Replace the valve and reface the valve seat.

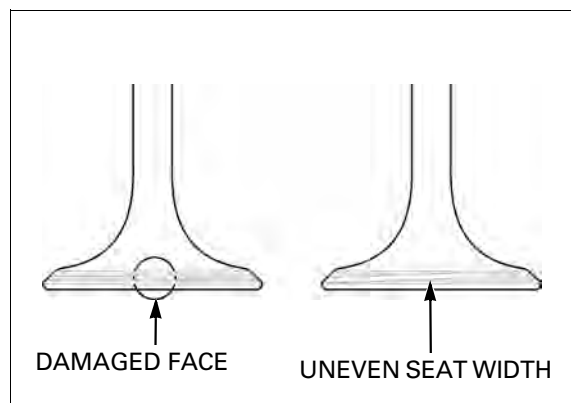

CYLINDER HEAD/VALVES

The valve cannot be ground. If the valve face is burned or badly worn or if it contacts the seat unevenly, replace the valve.

- Contact area (too low or too high)
 - Reface the valve seat.

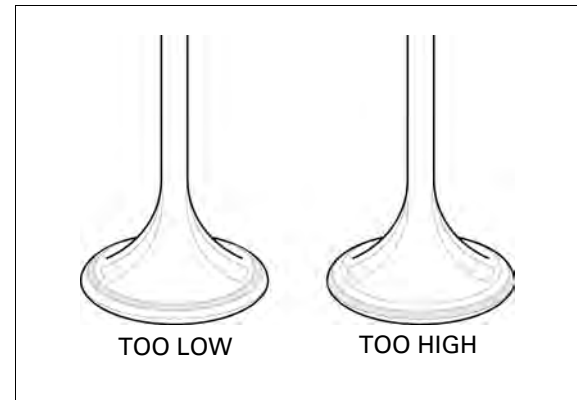

VALVE SEAT REFACING

Follow the refacing manufacturer's operating instructions. Be careful not to grind the seat more than necessary.

Valve seat cutters/grinders or equivalent valve seat refacing equipment are recommended to correct worn valve seats.

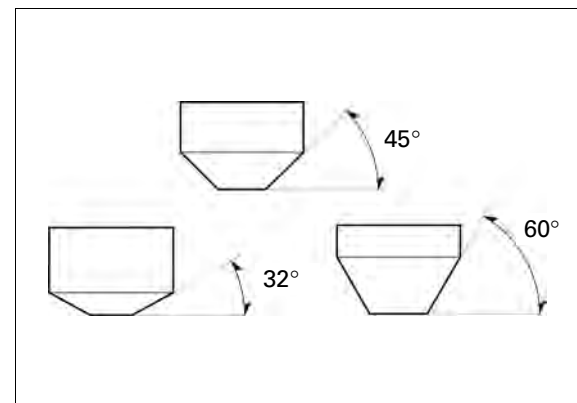

If the contact area is too high on the valve, the seat must be lowered using a 32° flat cutter.

If the contact area is too low on the valve, the seat must be raised using a 60° inner cutter.

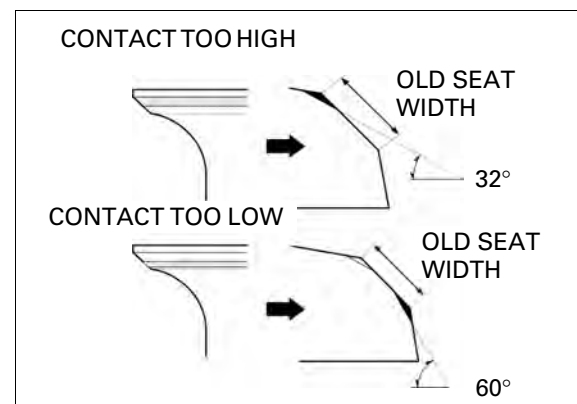

Reface the valve seat with a 45° cutter when a valve guide is replaced.

Using a 45° cutter, remove any roughness or irregularities from the seat.

TOOLS:

- Valve seat cutter, 33 mm (45° IN) 07780-0010800
- Valve seat cutter, 24.5 mm (45° EX) 07780-0010100
- Cutter holder, 5.5 mm 07781-0010101

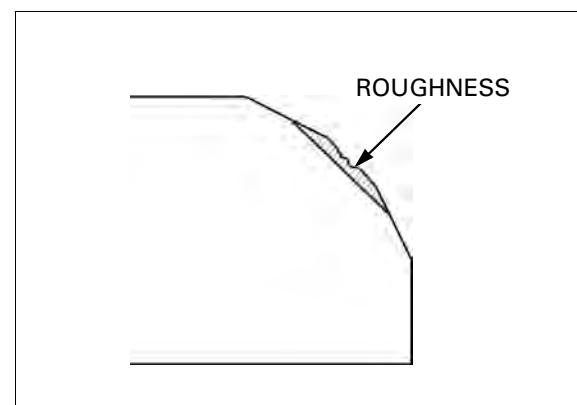

CYLINDER HEAD/VALVES

Using a 32° cutter, remove the top 1/4 of the existing valve seat material.

TOOLS:

Flat cutter, 33 mm (32° IN)	07780-0012900
Flat cutter, 25 mm (32° EX)	07780-0012000
Cutter holder, 5.5 mm	07781-0010101

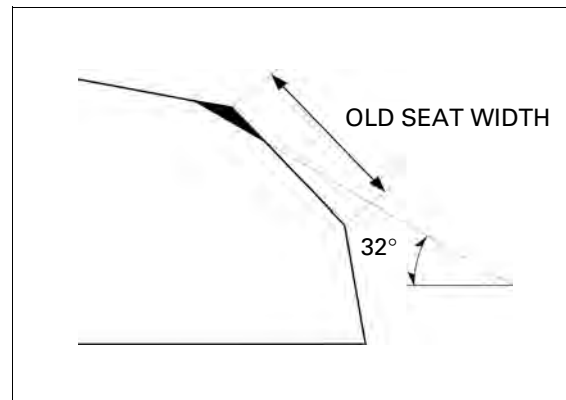

Using a 60° cutter, remove the bottom 1/4 of the existing valve seat material.

TOOLS:

Interior cutter, 30 mm (60° IN)	07780-0014000
Interior cutter, 30 mm (60° EX)	07780-0014000
Cutter holder, 5.5 mm	07781-0010101

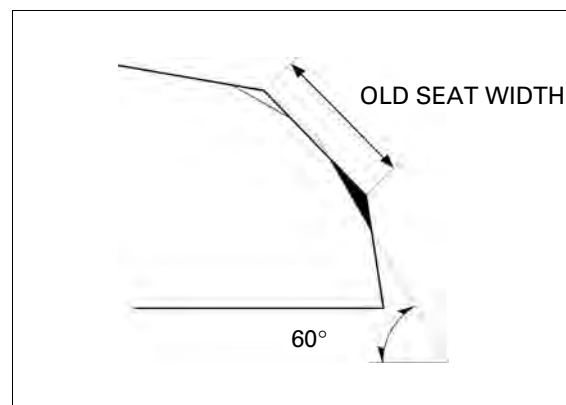

Using a 45° cutter, cut the seat to the proper width.

Make sure that all pitting and irregularities are removed.
Refinish if necessary.

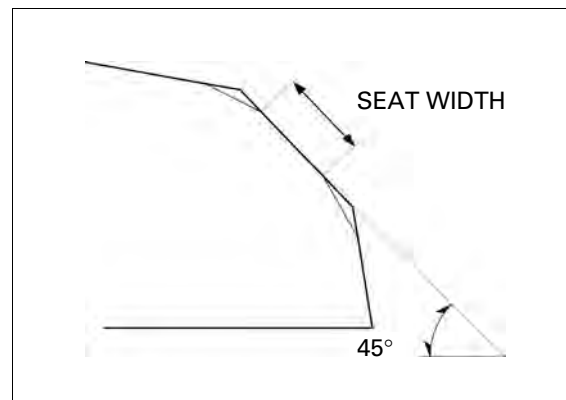

After cutting the seat, apply lapping compound to the valve face, and lap the valve lightly.

- Excessive lapping pressure may deform or damage the seat.
- Change the angle of the lapping tool frequently to prevent uneven seat wear.
- Do not allow the lapping compound to enter the valve guides.

After lapping, wash all residual compound off the cylinder head and valve and recheck the seat contact.

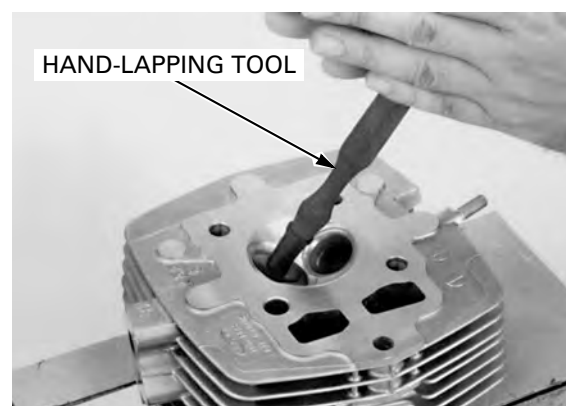

CYLINDER HEAD/VALVES

ASSEMBLY

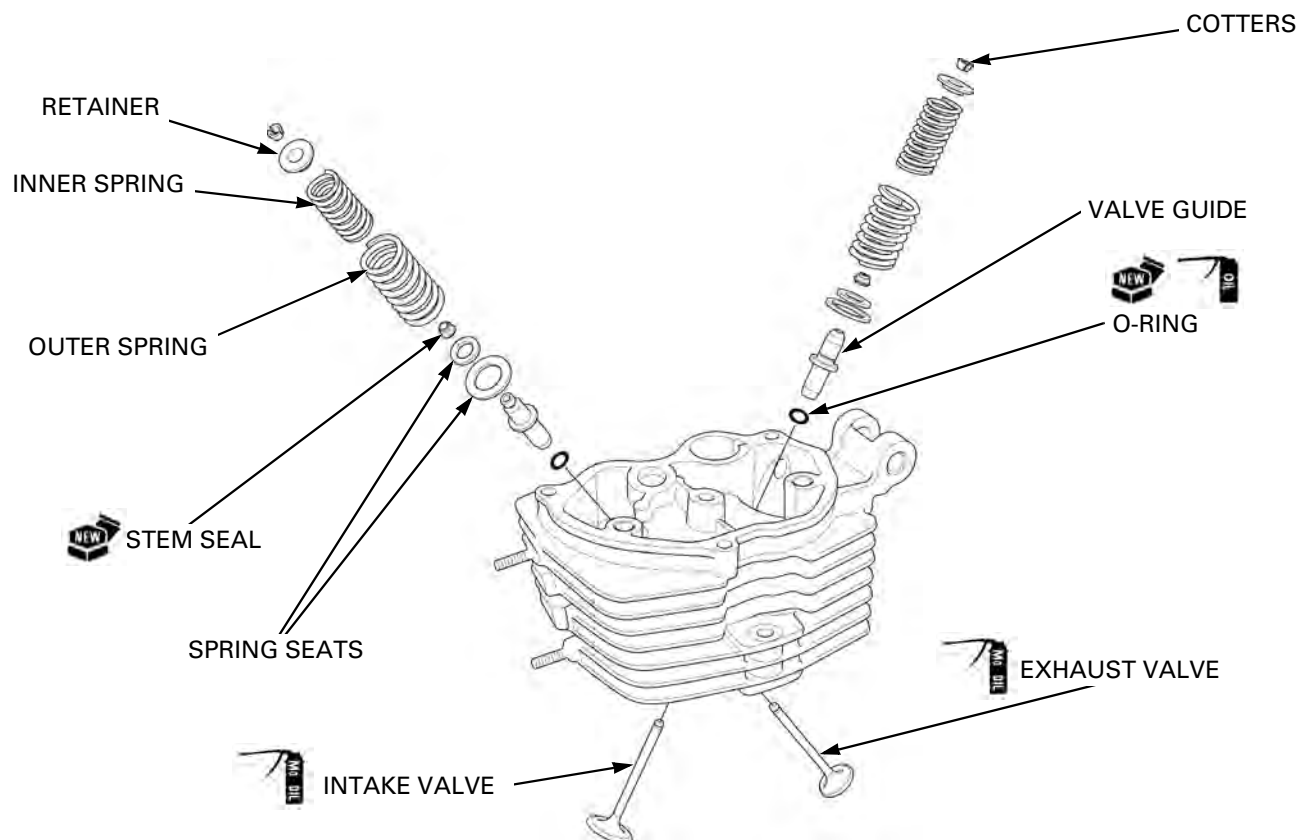

To avoid damage to the seal, turn the valve slowly when inserting.

Clean the cylinder head assembly with solvent and blow through all oil passages with compressed air. Install a new valve stem seals. Lubricate each valve stem with molybdenum oil solution. Insert the intake and exhaust valve into the valve guides.

Install the valve spring seats, springs and retainers. Install the valve springs with the narrow pitched end facing the combustion chamber.

To prevent loss of tension, do not compress the valve spring more than necessary.

Compress the valve spring and install the valve cot-
ters.

TOOLS:
Valve spring compressor 07757-0010000

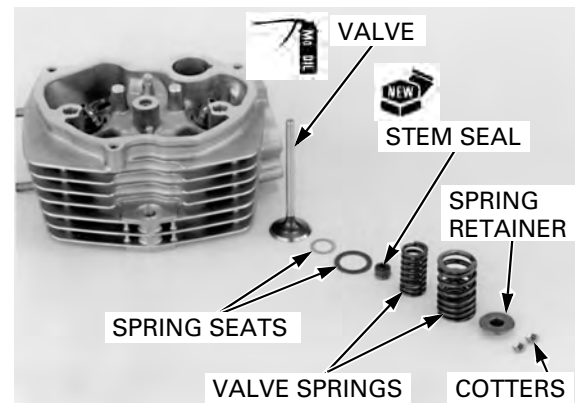

CYLINDER HEAD/VALVES

Support the cylinder head above the work bench surface to prevent valve damage.

Tap the stems with two plastic hammers to firmly seat the cotters.

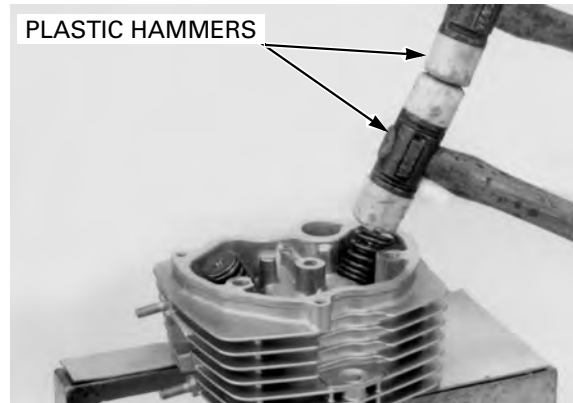

INSTALLATION

Do not allow dust and dirt to enter the engine.

Clean any gasket material from the cylinder mating surfaces.

Install the dowel pins and new cylinder head gasket.

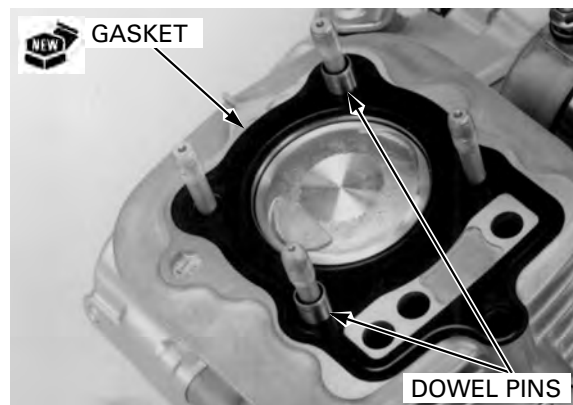

Install the cylinder head.

When installing the left side cylinder head bolt, align the hole in the cam follower shaft using a screwdriver as shown. Install the bolt but do not tighten it yet.

Install the left side cylinder head bolt and new sealing washer.

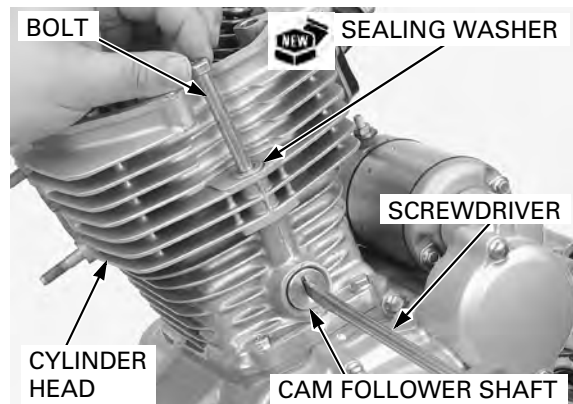

Apply clean engine oil to the cylinder head nut threads.

Tighten the cylinder head nuts in a crisscross pattern in 2 or 3 steps.

Install the new cylinder head washers and nuts. Tighten the fasteners in order as follows.

TORQUES:

Cylinder head nut: 32 N·m (3.3 kgf·m, 24 lbf·ft)
Cylinder head bolt: 20 N·m (2.0 kgf·m, 15 lbf·ft)
Cylinder bolt: 10 N·m (1.0 kgf·m, 7 lbf·ft)

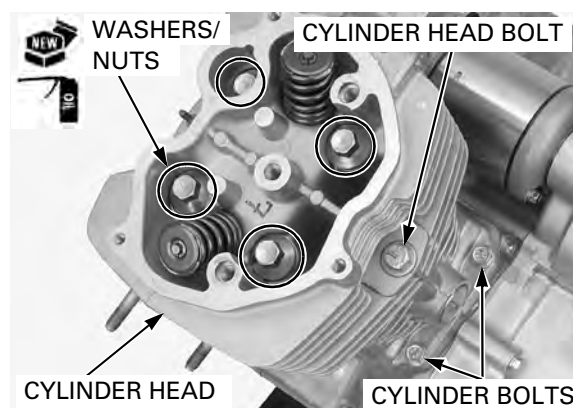

CYLINDER HEAD/VALVES

The push rods are interchangeable.

Apply clean engine oil to the ends of the push rods.

Install the push rods.

Install the following:

- Rocker arm holder (page 7-11)
- Cylinder head cover (page 7-8)
- Engine (page 6-10)

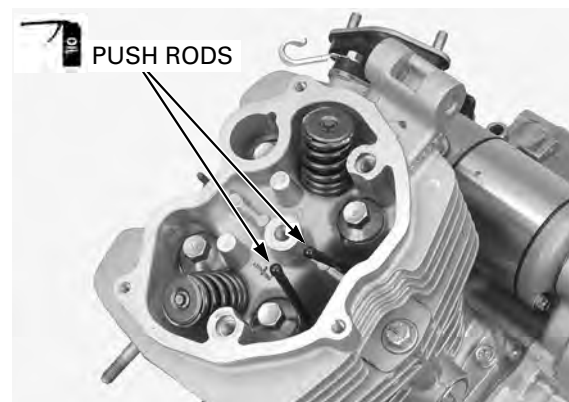

MEMO

8. CYLINDER/PISTON/CAMSHAFT

SYSTEM COMPONENTS	8-2	CAM FOLLOWER/SHAFT	8-6
SERVICE INFORMATION	8-3	CAMSHAFT	8-7
TROUBLESHOOTING	8-3	PISTON	8-10
CYLINDER	8-4		

**CYLINDER/PISTON/CAMSHAFT
SYSTEM COMPONENTS**

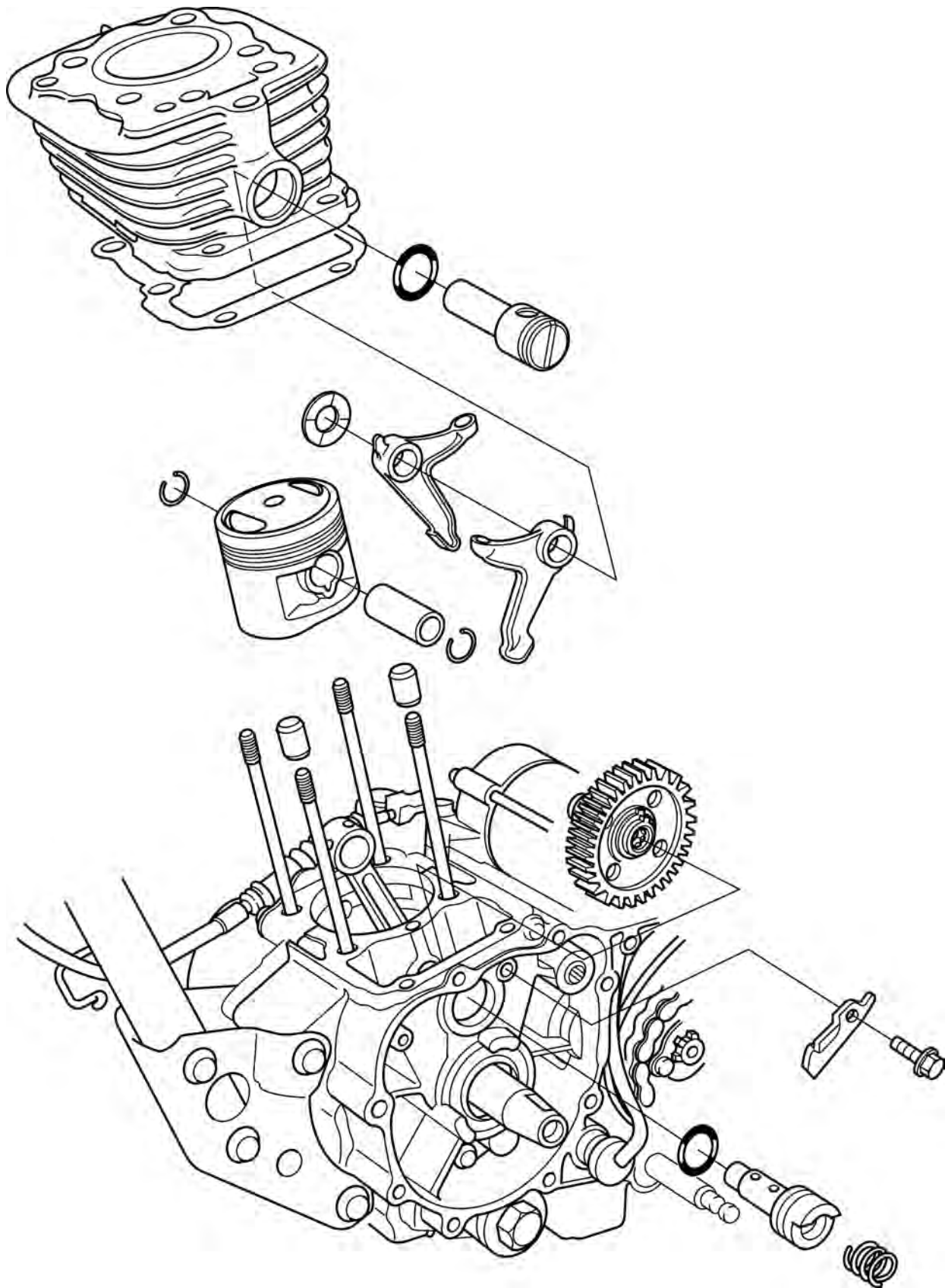

SERVICE INFORMATION

GENERAL

- The engine must be removed from the frame to service the cylinder, piston and camshaft.
- Be careful not to damage the mating surfaces when removing the cylinder. Do not strike the cylinder too hard during removal.
- Rocker arm lubricating oil is fed through an oil passage in the cylinder. Clean the oil passage before installing cylinder.

SPECIFICATIONS

Unit: mm (in)

ITEM		STANDARD	SERVICE LIMIT	
Camshaft	Cam lobe height	32.768 – 32.928 (1.2901 – 1.2964)	32.63 (1.285)	
	Camshaft I.D.	14.060 – 14.078 (0.5535 – 0.5543)	14.123 (0.5560)	
	Cam gear shaft O.D.	14.030 – 14.040 (0.5524 – 0.5528)	14.017 (0.5518)	
	Camshaft-to-gear shaft clearance	0.020 – 0.048 (0.0008 – 0.0019)	0.106 (0.0042)	
	Cam follower I.D.	12.000 – 12.018 (0.4724 – 0.4731)	12.03 (0.474)	
	Cam follower shaft O.D.	11.984 – 11.994 (0.4718 – 0.4722)	11.96 (0.471)	
	Cam follower-to-follower shaft clearance	0.006 – 0.034 (0.0002 – 0.0013)	0.07 (0.003)	
Cylinder	I.D.	56.500 – 56.512 (2.2244 – 2.2249)	56.60 (2.228)	
	Out-of-round	–	0.10 (0.004)	
	Taper	–	0.10 (0.004)	
	Warpage	–	0.05 (0.002)	
Piston, piston pin, piston ring	Piston O.D. at 8 (0.3) from bottom	56.470 – 56.490 (2.2232 – 2.2240)	56.40 (2.220)	
	Piston pin hole I.D.	15.002 – 15.008 (0.5906 – 0.5909)	15.04 (0.592)	
	Piston pin O.D.	14.994 – 14.998 (0.5903 – 0.5905)	14.96 (0.589)	
	Piston-to-piston pin clearance	0.004 – 0.014 (0.0002 – 0.0006)	0.02 (0.001)	
	Piston ring end gap	Top	0.10 – 0.25 (0.004 – 0.010)	0.5 (0.02)
		Second	0.25 – 0.40 (0.010 – 0.016)	0.5 (0.02)
		Oil (side rail)	0.20 – 0.70 (0.008 – 0.028)	–
	Piston ring-to-ring groove clearance	Top	0.015 – 0.045 (0.0006 – 0.0018)	0.09 (0.004)
Second		0.015 – 0.045 (0.0006 – 0.0018)	0.09 (0.004)	
Cylinder-to-piston clearance		0.010 – 0.042 (0.0004 – 0.0017)	0.10 (0.004)	
Connecting rod small end I.D.		15.010 – 15.022 (0.5909 – 0.5914)	15.06 (0.593)	
Connecting rod-to-piston pin clearance		0.012 – 0.028 (0.0005 – 0.0011)	0.10 (0.004)	

TROUBLESHOOTING

Compression too low, hard starting or poor performance at low speed

- Leaking cylinder head gasket
- Worn, stuck or broken piston ring
- Worn or damaged cylinder and piston
- Loose spark plug

Compression too high, overheating or knocking

- Excessive carbon built-up on piston head or combustion chamber

Excessive smoke

- Worn cylinder, piston or piston rings
- Improper installation of piston rings
- Scored or scratched piston or cylinder wall

Abnormal noise

- Worn piston pin or piston pin hole
- Worn connecting rod small end
- Worn cylinder, piston or piston rings

CYLINDER/PISTON/CAMSHAFT

CYLINDER

REMOVAL

Remove the cylinder head (page 7-12).
Remove the cylinder bolts and cylinder.

Do not strike the cylinder too hard and do not damage the mating surface with a screwdriver.

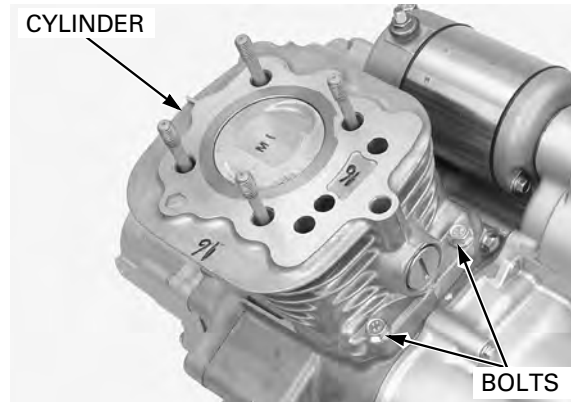

Be careful not to damage the cylinder surface and not to let the dust or dirt fall into the crankcase.

Remove the dowel pins and gasket.

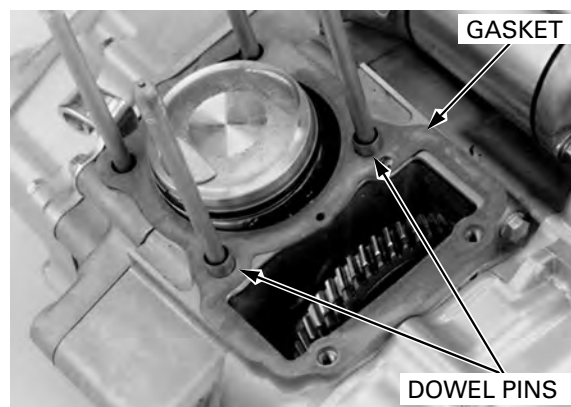

INSPECTION

Remove any gasket material from the cylinder surface.
Check the cylinder for warpage with a straight edge and a feeler gauge.

SERVICE LIMIT: 0.05 mm (0.002 in)

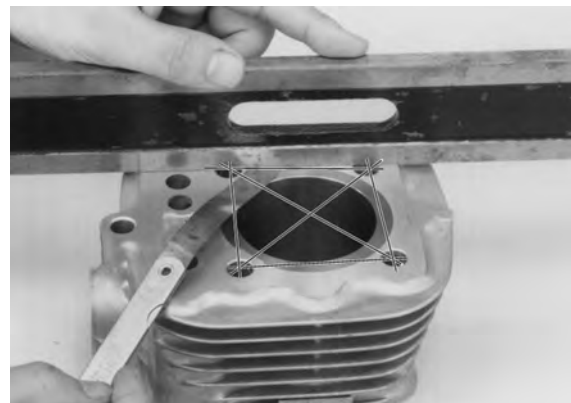

Inspect the cylinder bore for scratch, wear or damage.
Measure the cylinder I.D. in X and Y axis at three levels.
Take the maximum reading to determine the cylinder wear.

SERVICE LIMIT: 56.60 mm (2.228 in)

Measure the piston O.D. (page 8-10) and calculate the cylinder-to-piston clearance.
Take a maximum reading to determine the clearance.

SERVICE LIMIT: 0.10 mm (0.004 in)

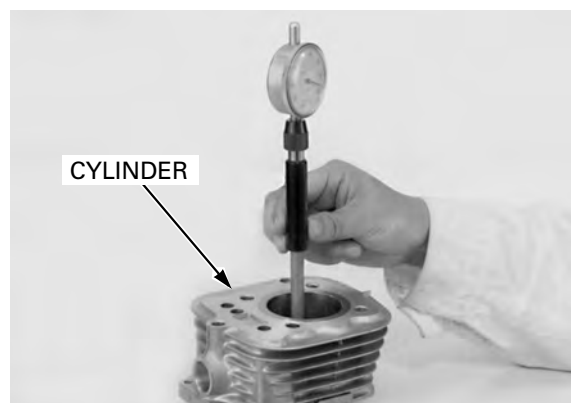

CYLINDER/PISTON/CAMSHAFT

Calculate the taper and out of round at three levels in an X and Y axis.
Take the maximum reading to determine the taper.

Taper: 0.10 mm (0.004 in)
Out-of-round: 0.10 mm (0.004 in)

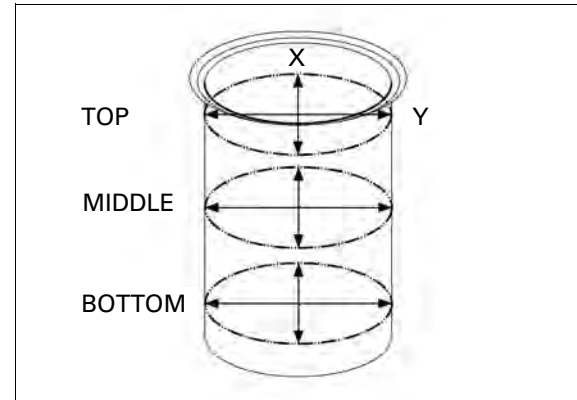

INSTALLATION

Clean off any gasket material from the crankcase surface.

Apply liquid sealant (THREE BOND #1141 or equivalent) to the cylinder-to-crankcase hatched area as shown.

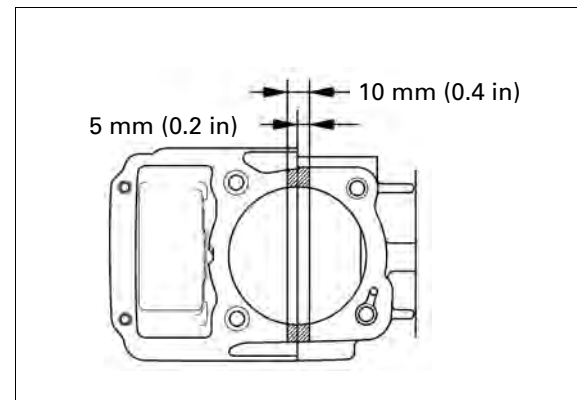

Install the dowel pins and new gasket.

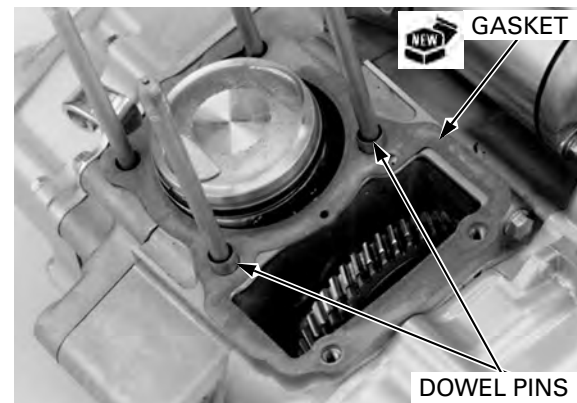

Apply clean engine oil to the cylinder inner surface, piston rings/grooves and piston.

Be careful not to damage the piston ring and cylinder wall while installation.

Install the cylinder while compressing the piston rings.

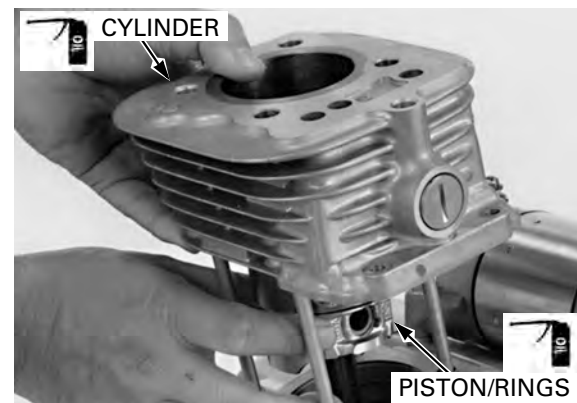

CYLINDER/PISTON/CAMSHAFT

Install the cylinder bolts.

Install the following:

- Cylinder head (page 7-20)
- Rocker arm (page 7-11)
- Cylinder head cover (page 7-8)
- Engine (page 6-10)

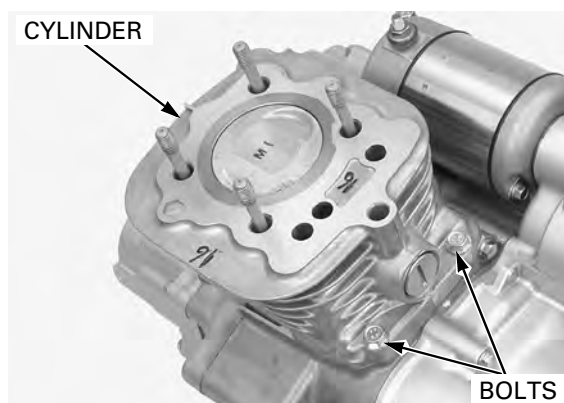

CAM FOLLOWER/SHAFT

REMOVAL

Remove the cylinder (page 8-4).

Remove the cam follower shaft using a screwdriver as shown.

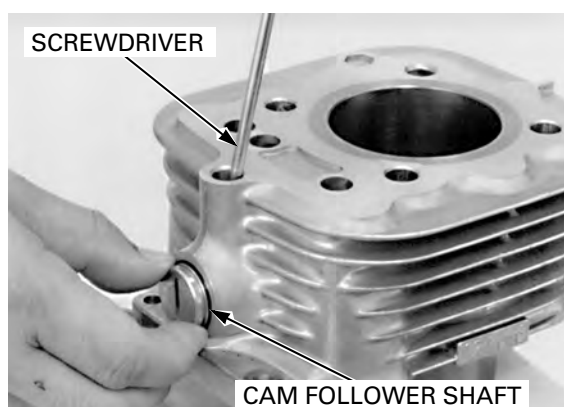

Remove the cam followers and wave washer.
Remove the O-ring from the cam follower shaft.

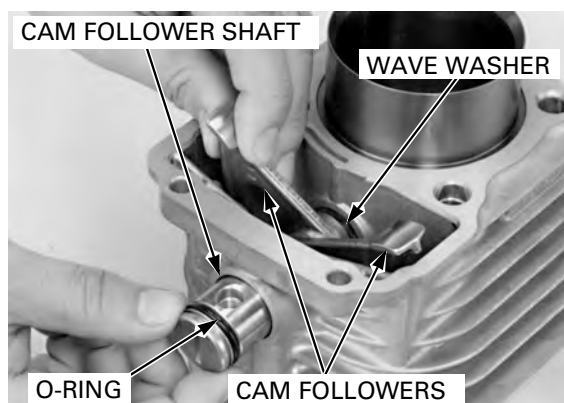

INSPECTION

Check the cam followers for wear, damage or clogged oil holes.

If any cam follower requires servicing or replacement, inspect the cam lobe for scoring, chipping or excessive wear.

Measure the cam follower I.D.

SERVICE LIMIT: 12.03 mm (0.474 in)

Measure the cam follower shaft O.D.

SERVICE LIMIT: 11.96 mm (0.471 in)

Calculate the cam follower-to-follower shaft clearance.

SERVICE LIMIT: 0.07 mm (0.003 in)

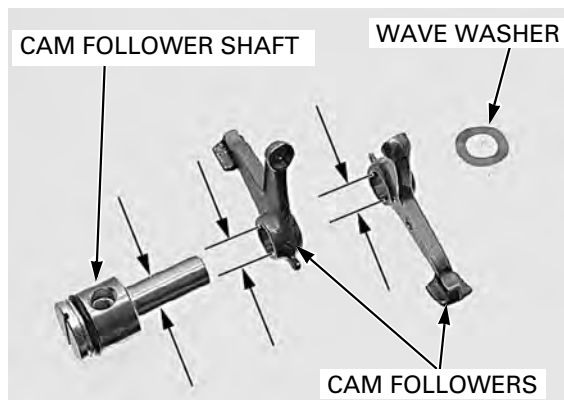

INSTALLATION

Apply molybdenum oil to the cam follower shaft sliding surfaces.
Install a new O-ring onto the cam follower shaft groove.
Install the wave washer, cam followers and cam follower shaft.

Install the following:

- Cylinder (page 8-5)
- Cylinder head (page 7-20)
- Rocker arm (page 7-11)
- Cylinder head cover (page 7-8)
- Engine (page 6-10)

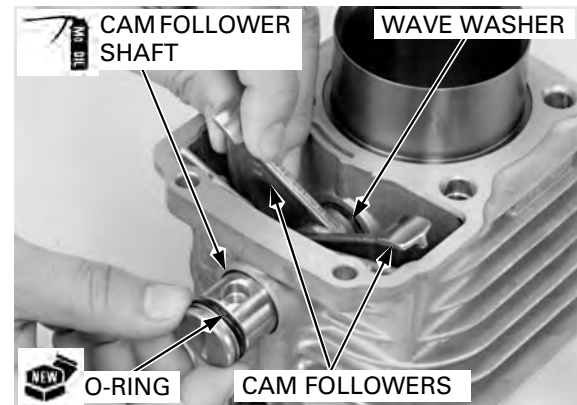

CAMSHAFT

REMOVAL

Remove the following:

- Cylinder (page 8-4)
- Flywheel (page 10-6)

Remove the bolt and spring stopper plate.

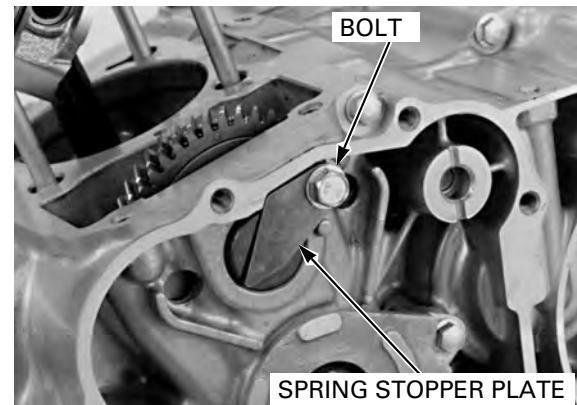

Remove the camshaft spring.



Remove the cam gear shaft using the pliers.
Remove the camshaft/cam gear.

Remove the O-ring from the cam gear shaft.

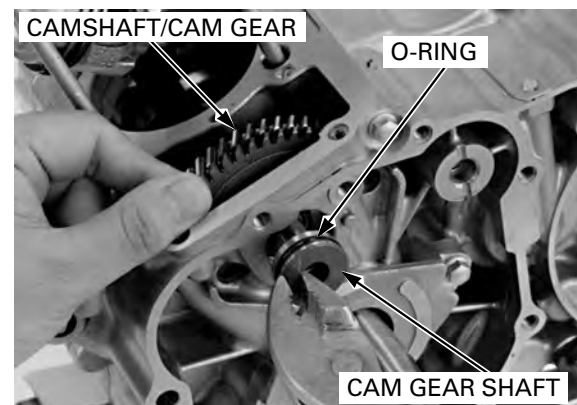

CYLINDER/PISTON/CAMSHAFT

INSPECTION

Check the cam gear for wear or damage.

Check the cam lobe for wear or damage.
Measure the cam lobe height.

SERVICE LIMIT: 32.63 mm (1.285 in)

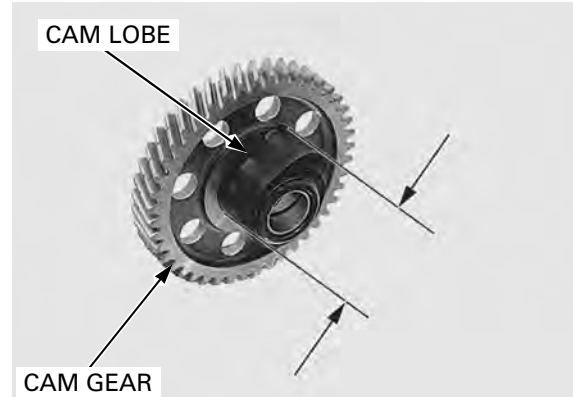

Measure the camshaft I.D.

SERVICE LIMIT: 14.123 mm (0.5560 in)

Measure the cam gear shaft O.D.

SERVICE LIMIT: 14.017 mm (0.5518 in)

Calculate the camshaft-to-gear shaft clearance.

SERVICE LIMIT: 0.106 mm (0.0042 in)

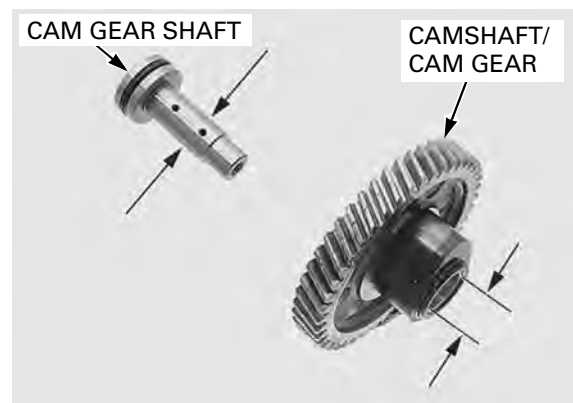

INSTALLATION

Lubricate the cam lobe, camshaft inner surface and cam gear with molybdenum oil.

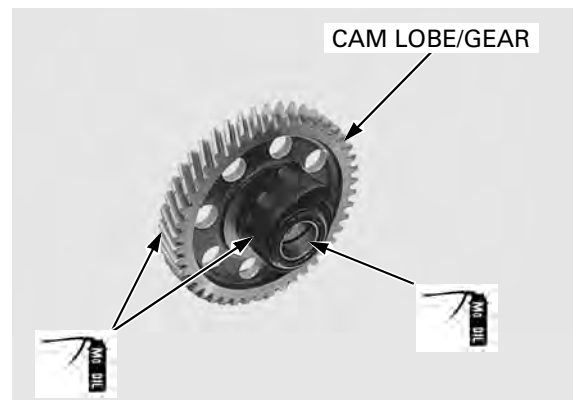

Install the camshaft into the crankcase with the cam lobe side facing inward.

Align the punch marks between the camshaft drive gear and cam gear, then align the gear teeth using a screwdriver.

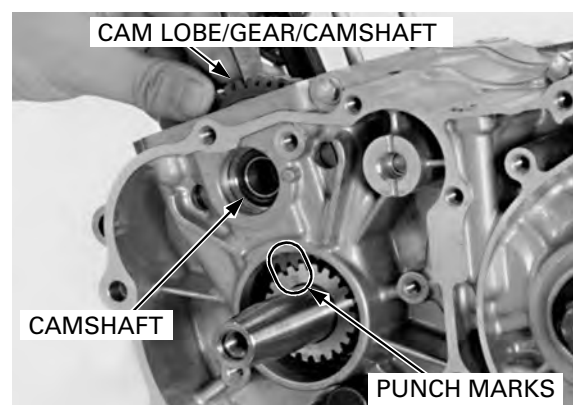

CYLINDER/PISTON/CAMSHAFT

Install a new O-ring into the cam gear shaft groove and apply oil to the new O-ring. Apply clean engine oil to the cam gear shaft. Hold the cam gear by hand and install the cam gear shaft into the crankcase.

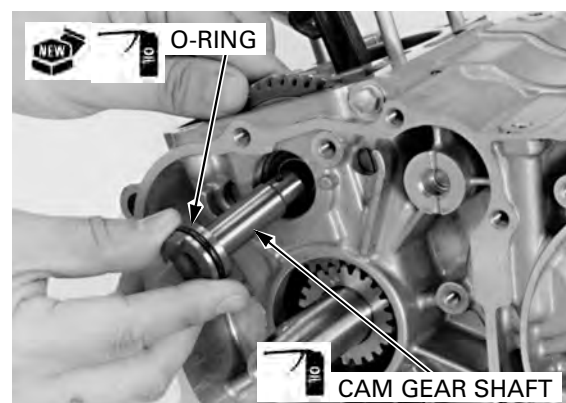

Install the camshaft spring.



Install the spring stopper plate and tighten the spring stopper plate bolt.

Install the following:

- Flywheel (page 10-9)
- Left crankcase cover (page 10-11)
- Cylinder (page 8-5)
- Cylinder head (page 7-20)
- Rocker arm (page 7-11)
- Cylinder head cover (page 7-8)
- Engine (page 6-10)

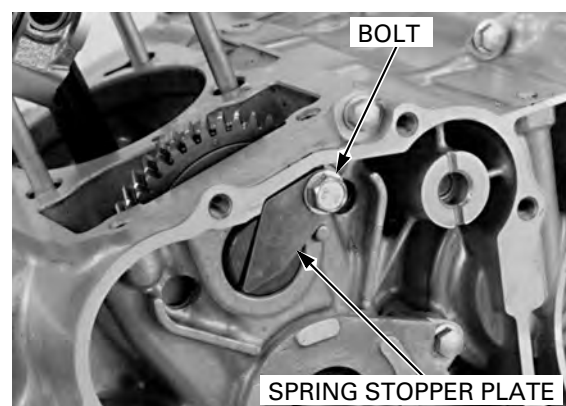

CYLINDER/PISTON/CAMSHAFT

PISTON

REMOVAL

Remove the cylinder (page 8-4).

Place a clean shop towel in the crankcase to prevent the piston pin clips or other parts from falling into the crankcase.

Remove the piston pin clip with pliers. Remove the piston pin and piston.

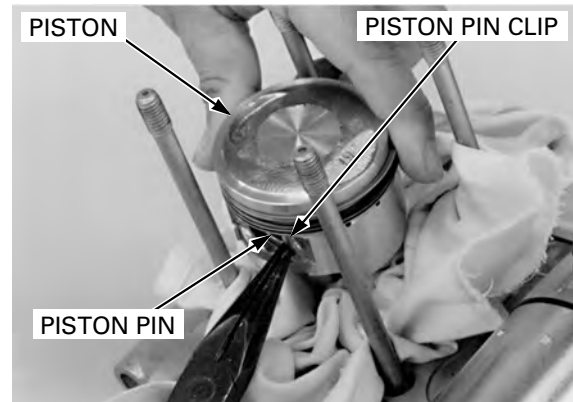

Do not damage the piston ring by spreading the ends too far.

Be careful not to damage the piston when removing the piston ring.

Spread each piston ring and remove it by lifting it up at a point just opposite the gap.



Clean carbon deposits from the piston ring grooves with a ring that will be discarded. Never use a wire brush because it scratches the grooves.



INSPECTION

Push the rings into the cylinder with the top of the piston to be sure they are inserted squarely in the cylinder.

Insert each piston ring into the cylinder using the piston head and measure the ring end gap in the cylinder at a point 10 mm (0.4 in) from the bottom.

SERVICE LIMIT:

Top/second: 0.5 mm (0.02 in)



CYLINDER/PISTON/CAMSHAFT

Temporarily install the piston ring to their proper position with the mark facing upward. Measure the piston ring-to-ring groove clearance with a feeler gauge.

SERVICE LIMIT:

Top/second: 0.09 mm (0.004 in)

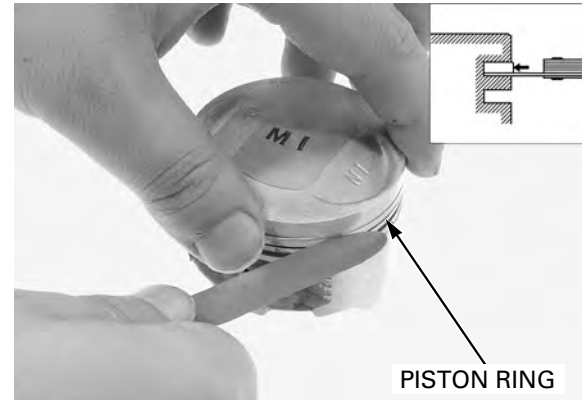

Measure the piston O.D. at 8 mm (0.3 in) from the bottom of the skirt at a 90 degree angle to the piston pin holes.

SERVICE LIMIT: 56.40 mm (2.220 in)

Compare this measurement with the service limit and use it to calculate the cylinder-to-piston clearance (page 8-3).

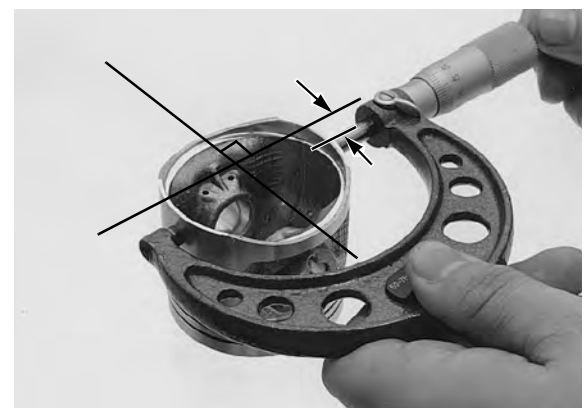

Measure the piston pin hole I.D.

SERVICE LIMIT: 15.04 mm (0.592 in)

Measure the piston pin O.D.

SERVICE LIMIT: 14.96 mm (0.589 in)

Calculate the piston-to-piston pin clearance.

SERVICE LIMIT: 0.02 mm (0.001 in)

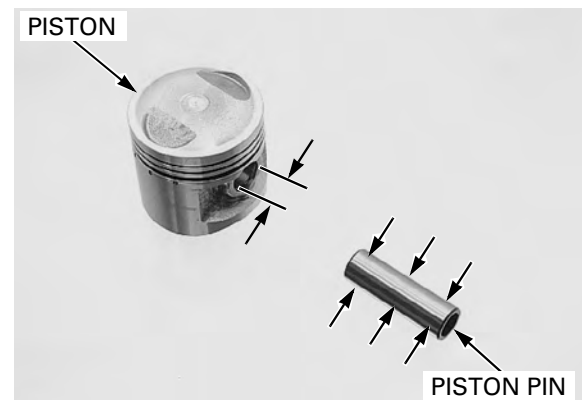

Measure the connecting rod small end I.D.

SERVICE LIMIT: 15.06 mm (0.593 in)

Calculate the connecting rod-to-piston pin clearance.

SERVICE LIMIT: 0.10 mm (0.004 in)

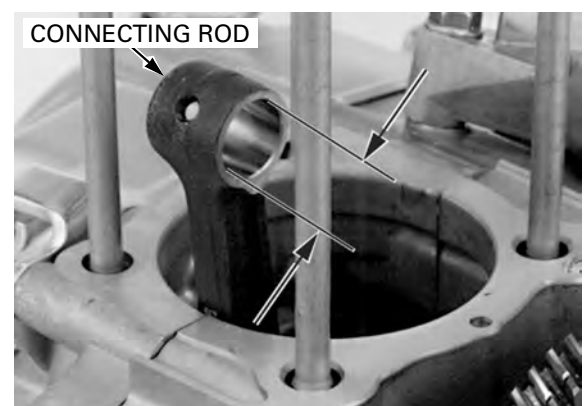

CYLINDER/PISTON/CAMSHAFT

INSTALLATION

Clean the piston head, ring land and skirt.

Insert the outside surface of the piston ring into the proper ring groove and rotate the ring in the groove to make sure that the ring has a free fit around the piston's circumference.

Carefully install the piston rings with the marking facing upward.

- Be careful not to damage the piston and piston rings during installation.
- Do not interchange the top ring with the second ring.

Stagger the piston ring end gaps at a 120-degree angle from each other as shown.

- When installing the oil ring, install the spacer first and then the side rails.
- Do not align the gaps of the oil ring side rails.

After installation, the piston rings should be free to rotate in the grooves.

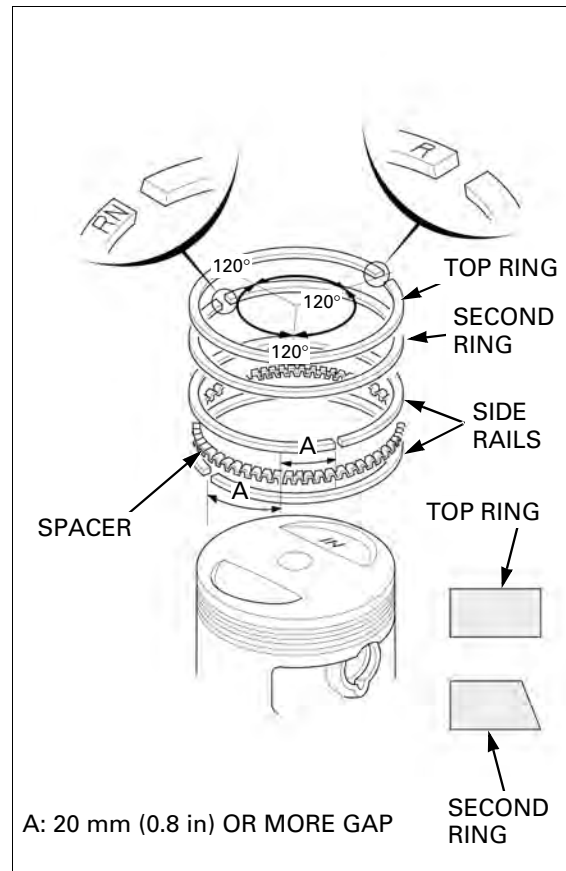

Place a clean shop towel in the crankcase to prevent the gasket or other parts from falling into the crankcase. Do not damage the cylinder gasket surface.

Remove any gasket material from the cylinder gasket surface of the crankcase.

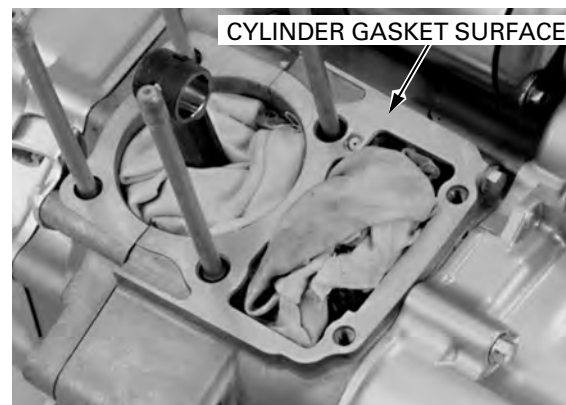

Apply molybdenum oil solution to the piston pin outer surface.

Place a clean shop towel in the crankcase to prevent the piston pin clips or other parts from falling into the crankcase.

Install the piston with the "IN" mark facing the intake side.

Do not reuse piston pin clips. Do not align the piston pin clip end gap with the piston cut-out.

Install the piston pin and new piston pin clips.

Install the following:

- Cylinder (page 8-5)
- Cylinder head (page 7-20)
- Rocker arm (page 7-11)
- Cylinder head cover (page 7-8)
- Engine (page 6-10)

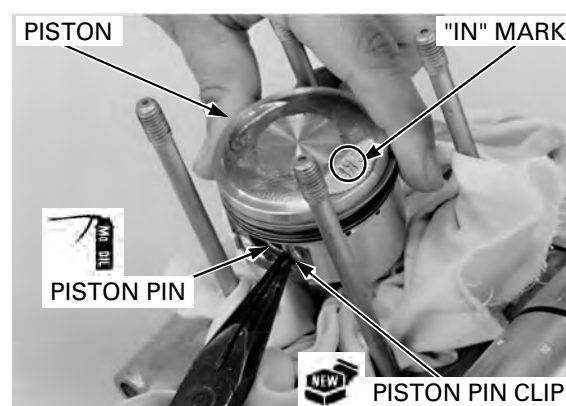

9. CLUTCH/GEARSHIFT LINKAGE

SYSTEM COMPONENTS	9-2	CLUTCH LIFTER ARM	9-6
SERVICE INFORMATION	9-3	CLUTCH.....	9-6
TROUBLESHOOTING	9-4	GEARSHIFT LINKAGE	9-11
RIGHT CRANKCASE COVER REMOVAL.....	9-5	RIGHT CRANKCASE COVER INSTALLATION.....	9-14

CLUTCH/GEARSHIFT LINKAGE SYSTEM COMPONENTS

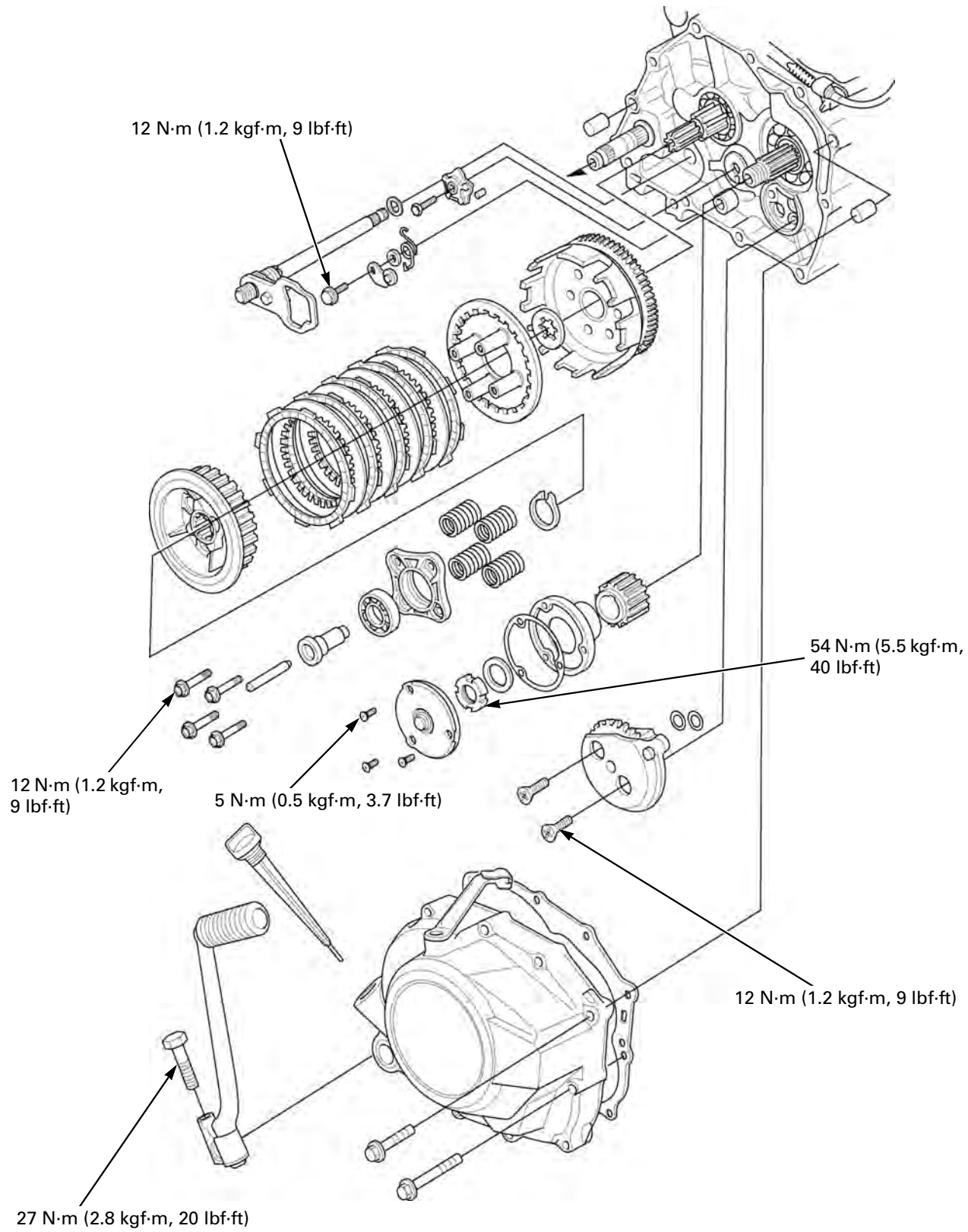

SERVICE INFORMATION

GENERAL

- This section covers maintenance of the clutch, gearshift linkage and right crankcase cover. These services can be performed with the engine installed in the frame.
- Engine oil viscosity and level have an effect on clutch disengagement. When the clutch does not disengage or the motorcycle creeps with clutch disengaged, inspect the engine oil and oil level before servicing the clutch system.

SPECIFICATIONS



ITEM		STANDARD	SERVICE LIMIT
Clutch lever free play		10 – 20 (0.4 – 0.8)	–
Clutch	Spring free length	35.50 (1.398)	34.20 (1.346)
	Disc thickness	2.90 – 3.00 (0.114 – 0.181)	2.6 (0.10)
	Plate warpage	–	0.20 (0.008)

Unit: mm (in)

TORQUE VALUES

Clutch lifter plate bolt	12 N·m (1.2 kgf·m, 9 lbf·ft)	Apply oil to the threads and seating surface.
Shift drum stopper arm bolt	12 N·m (1.2 kgf·m, 9 lbf·ft)	
Oil filter rotor lock nut	54 N·m (5.5 kgf·m, 40 lbf·ft)	
Oil filter rotor cover screw	5 N·m (0.5 kgf·m, 3.7 lbf·ft)	
Gearshift pedal pinch bolt	12 N·m (1.2 kgf·m, 9 lbf·ft)	
Kickstarter pedal pinch bolt	27 N·m (2.8 kgf·m, 20 lbf·ft)	

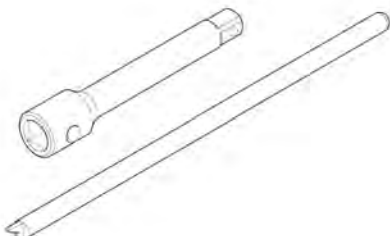
TOOLS

Lock nut wrench, 20 x 24 mm 07716-0020100 	Extension bar 07716-0020500 	Gear holder 07724-0010200 
---	--	---

CLUTCH/GEARSHIFT LINKAGE

TROUBLESHOOTING

Faulty clutch operation can usually be corrected by adjusting the free play.

Clutch lever difficult to pull in

- Damaged, kinked or dirty clutch cable
- Improperly routed clutch cable
- Damaged clutch lifter mechanism
- Faulty clutch lifter plate bearing

Clutch will not disengage or motorcycle creeps with clutch disengaged

- Excessive clutch lever free play
- Clutch plate warped
- Oil level too high, improper oil viscosity, or additive used
- Check for oil additive

Clutch slips

- Clutch lifter sticking
- Worn clutch discs
- Weak clutch springs
- Incorrect clutch adjustment
- Check for oil additive

Hard to shift

- Misadjusted clutch lever free play
- Damaged or bent shift fork
- Bent shift fork shaft
- Incorrect engine oil viscosity
- Incorrect gearshift spindle assembly
- Damaged shift drum guide grooves

Transmission jumps out of gear

- Worn shift drum stopper arm
- Worn or broken gearshift spindle return spring
- Bent shift fork shaft
- Damaged shift drum guide grooves
- Worn gear dogs or dog holes

Gearshift pedal will not return

- Weak or broken gearshift spindle return spring
- Bent gearshift spindle

RIGHT CRANKCASE COVER REMOVAL

REMOVAL

Drain engine oil into the clean container (page 3-10).

Remove the muffler (page 2-8).

Remove the footpeg bar assembly (page 2-8).

Loosen the clutch cable lock nut and clutch cable adjusting nut.

Release the clutch cable from the stay and disconnect the clutch cable end from the lifter arm.

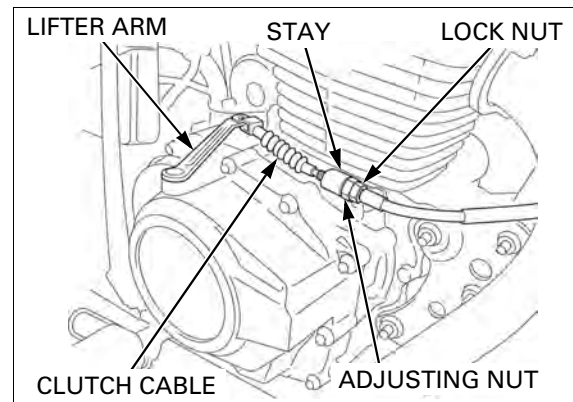

Remove the bolt and kickstarter pedal.

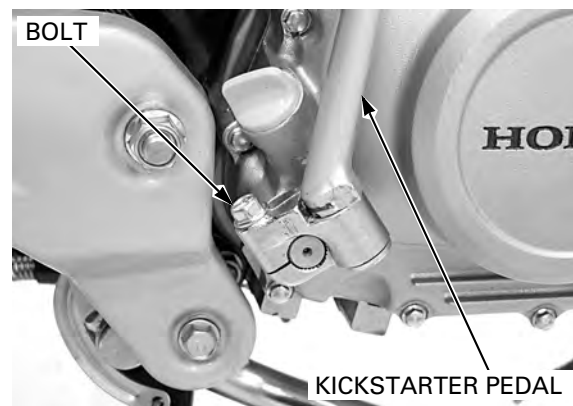

Loosen the bolts in a crisscross pattern in 2 or 3 steps.

Remove the bolts and right crankcase cover.

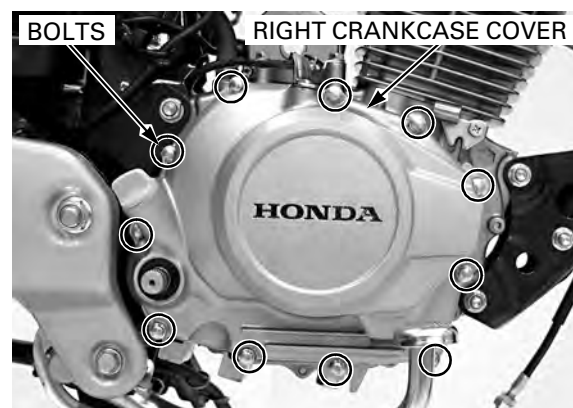

Remove the gasket and dowel pins.

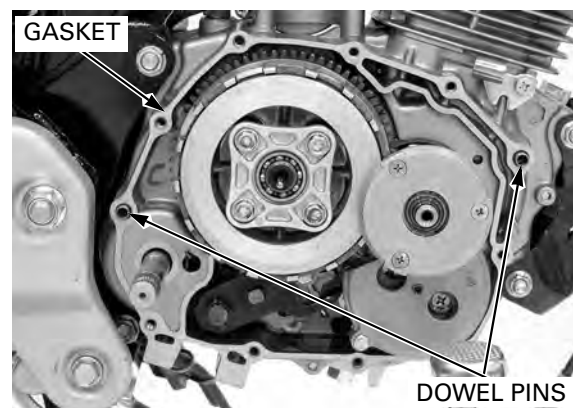

CLUTCH/GEARSHIFT LINKAGE

CLUTCH LIFTER ARM

REMOVAL/INSTALLATION

Remove the cotter pin and remove the clutch lifter arm and return spring.

Visually inspect the clutch arm for bending or damage.

Install the clutch arm on the right crankcase cover in the reverse order of removal with a new cotter pin.

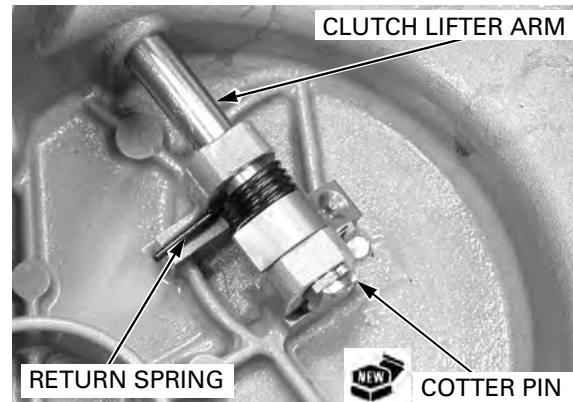

CLUTCH

REMOVAL

Remove the right crankcase cover (page 9-5).

Remove the screws, oil filter rotor cover and gasket.



Hold the primary drive/driven gear with gear holder and remove the oil filter rotor lock nut by using the special tool.

TOOLS:

Gear holder	07724-0010200
Lock nut wrench, 20 x 24 mm	07716-0020100
Extension bar	07716-0020500

Remove the lock washer and oil filter rotor.

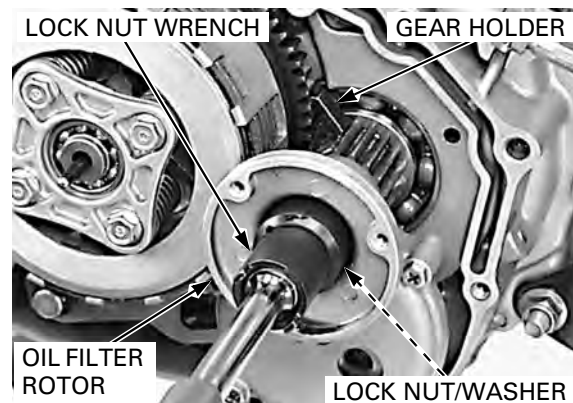

Remove the clutch lifter rod and clutch lifter guide pin.

Loosen the bolts in a crisscross pattern in 2 or 3 steps.

Remove the clutch bolts, clutch lifter plate and clutch spring.

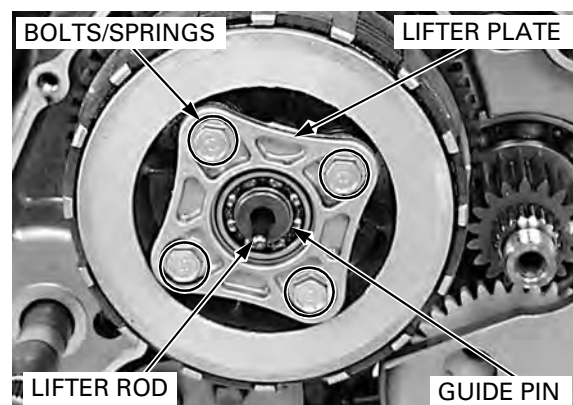

CLUTCH/GEARSHIFT LINKAGE

Remove the following:

- Snap ring
- Clutch center
- Clutch discs
- Clutch plates
- Pressure plate

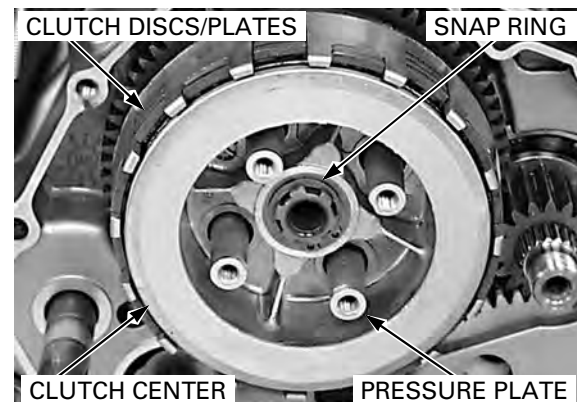

Rotate and align the spline washer teeth with mainshaft grooves.
Remove the spline washer and clutch outer.
Remove the primary drive gear.

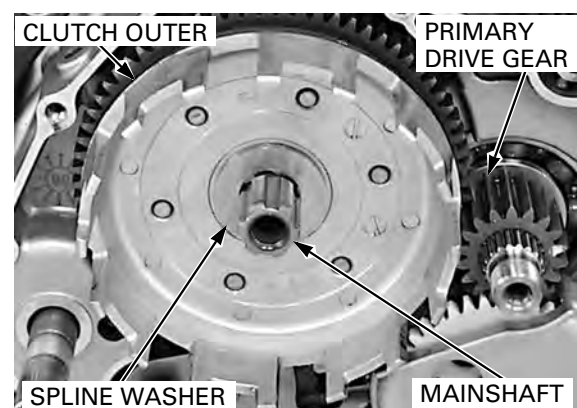

INSPECTION

Clutch lifter rod/lifter guide pin

Visually inspect the clutch lifter rod and lifter guide pin for wear or damage.

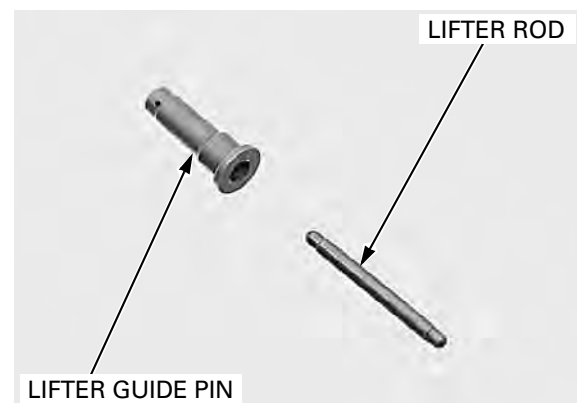

Clutch lifter bearing

Turn the inner race of the lifter bearing with your finger.
The bearing should turn smoothly and quietly.
Also check that the outer race of the bearing fits tightly in the lifter plate.
Replace the bearing if the inner race does not turn smoothly, quietly, or if the outer race fits loosely in the lifter plate.

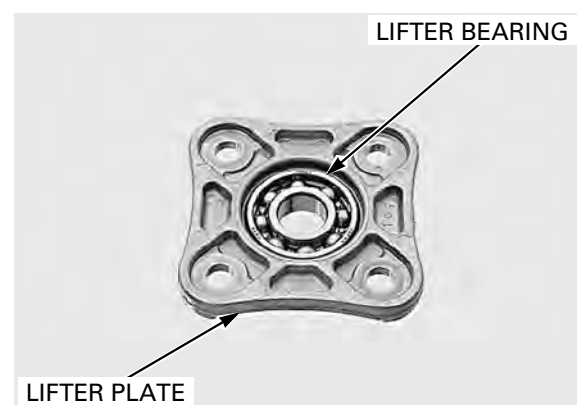

CLUTCH/GEARSHIFT LINKAGE

Clutch spring

Replace the clutch springs as a set.

Measure the clutch spring free length.

SERVICE LIMIT: 34.20 mm (1.346 in)

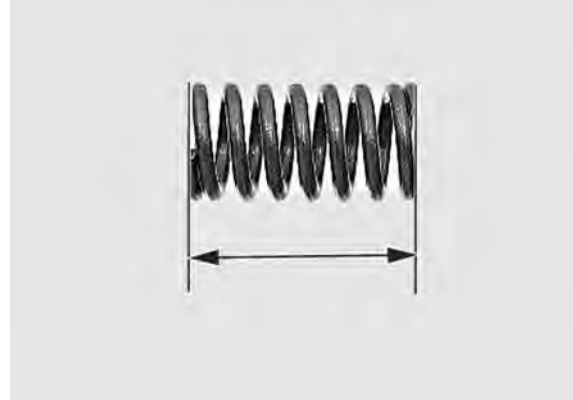

Clutch disc

Replace the clutch discs and plates as a set.

Check the clutch discs for signs of scoring or discoloration.

Measure the thickness of each disc.

SERVICE LIMIT: 2.6 mm (0.10 in)



Clutch plate

Replace the clutch discs and plates as a set.

Check the plate for discoloration.

Check the clutch plate for warpage on a surface plate by using a feeler gauge.

SERVICE LIMIT: 0.20 mm (0.008 in)

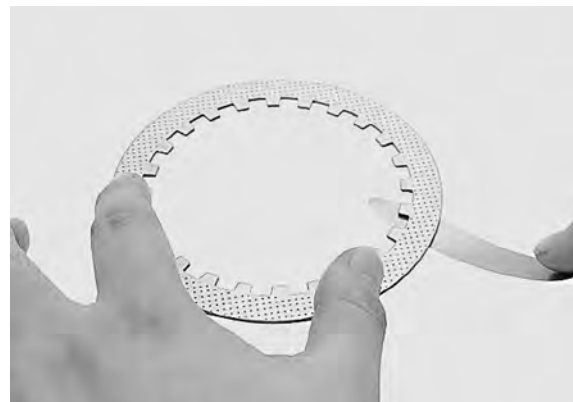

Clutch outer

Check the slots in the clutch outer for nicks, cuts or indentations made by the clutch discs.

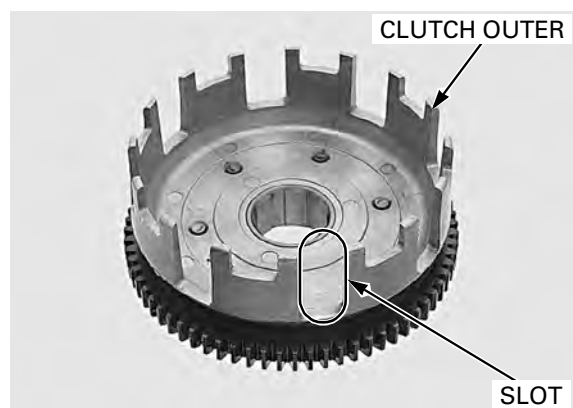

CLUTCH/GEARSHIFT LINKAGE

Clutch center

Check the grooves of the clutch center for damage or wear caused by the clutch plates.

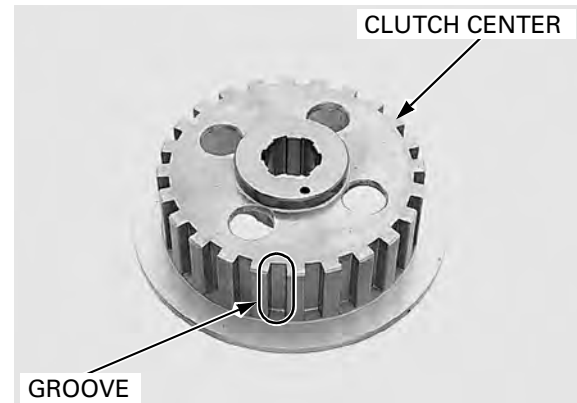

Oil filter rotor

Check the oil through pipe operates freely, without binding. If necessary, remove the B-clip and replace the faulty part.

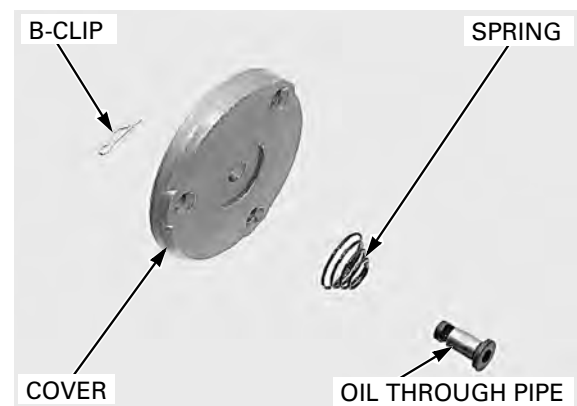

INSTALLATION

Install the clutch outer and spline washer. Apply engine oil to the primary drive gear. Install the primary drive gear.

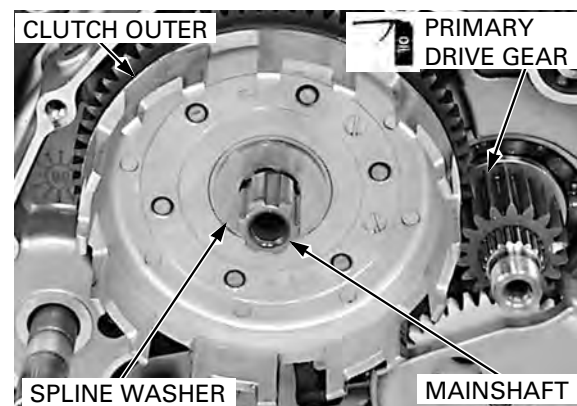

Coat the clutch discs with clean engine oil. Assemble the clutch discs, clutch plates and pressure plate onto clutch center.

Install the tabs of the top clutch disc into the shallow slots in the clutch outer.

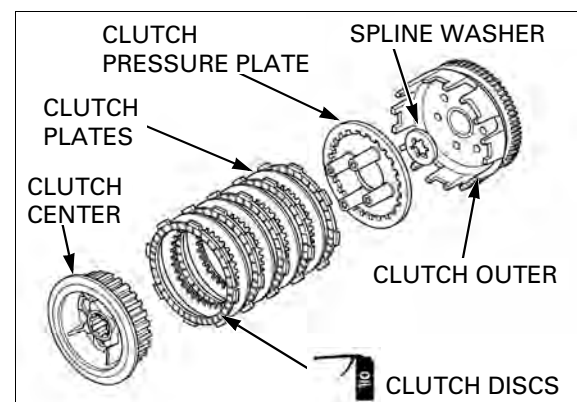

CLUTCH/GEARSHIFT LINKAGE

Install the clutch assembly to the mainshaft.
Install the snap ring into the mainshaft groove.

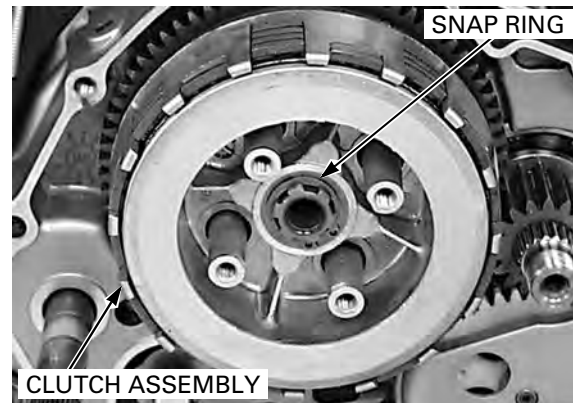

Install the clutch springs, lifter plate and bolts.

Tighten the lifter plate bolts in a crisscross pattern in several steps.

TORQUE: 12 N·m (1.2 kgf·m, 9 lbf·ft)

Apply clean engine oil to the clutch lifter rod.

Install the clutch lifter guide pin and clutch lifter rod.

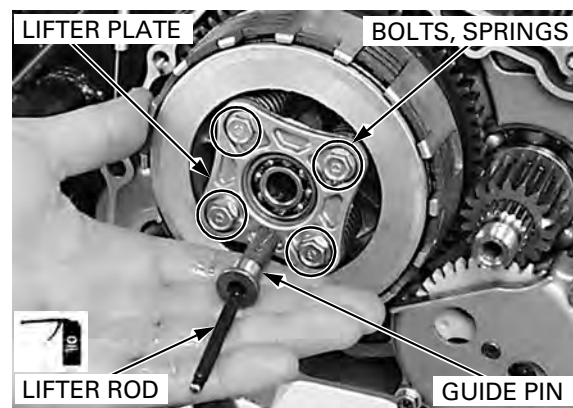

Install the lock washer with its "OUT SIDE" mark facing out.

Clean and apply engine oil to the oil filter rotor then install the oil filter rotor and lock washer onto the crankshaft.

Apply engine oil to the threads and seating surface of the lock nut and install it with the chamfered side facing in.

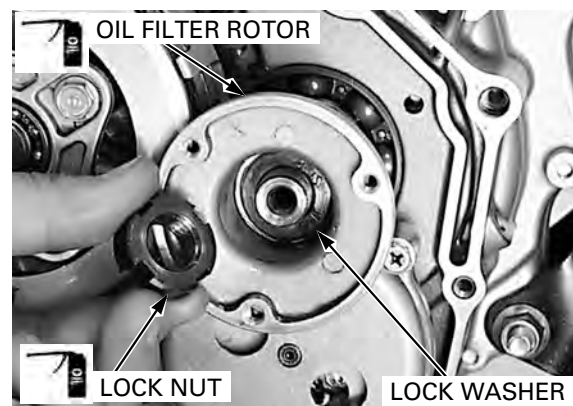

Hold the primary drive and driven gear with a gear holder and tighten the oil filter rotor lock nut by using the special tools.

TOOLS:

Gear holder	07724-0010200
Lock nut wrench, 20 x 24 mm	07716-0020100
Extension bar	07716-0020500

TORQUE: 54 N·m (5.5 kgf·m, 40 lbf·ft)

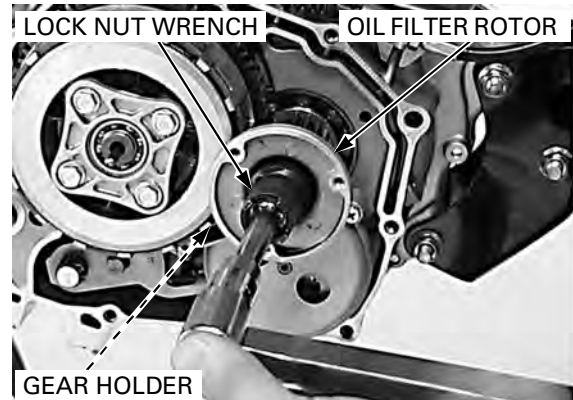

CLUTCH/GEARSHIFT LINKAGE

Install a new gasket onto the filter rotor cover.
Apply engine oil to the oil through sliding area.

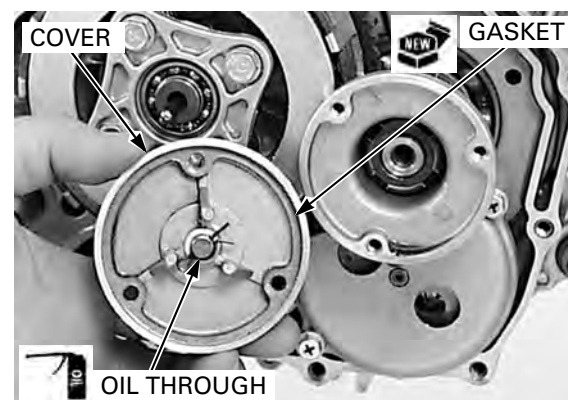

Install the filter rotor cover and tighten the screws.

TORQUE: 5 N·m (0.5 kgf·m, 3.7 lbf·ft)

Install the right crankcase cover (page 9-14)

Check that the clutch operates properly.



GEARSHIFT LINKAGE

REMOVAL

Remove the following:

- Clutch (page 9-6)
- Oil pump (page 4-5)

Remove the bolt and gearshift pedal.

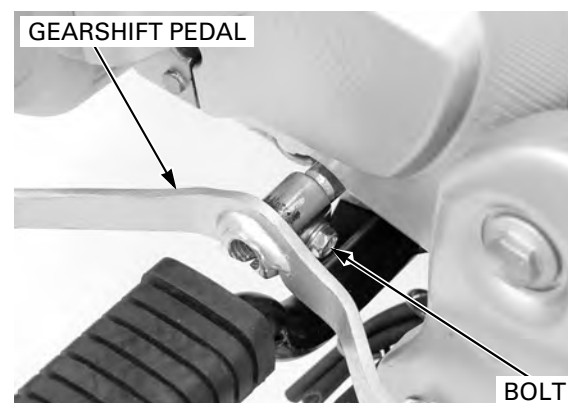

Pull the gearshift spindle out of the crankcase.

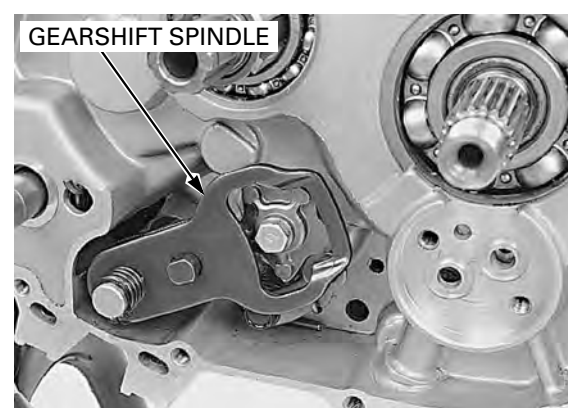

CLUTCH/GEARSHIFT LINKAGE

Remove the following:

- Stopper plate bolt
- Shift drum stopper plate
- Dowel pin from the shift drum
- Stopper arm bolt
- Stopper arm
- Washer
- Return spring

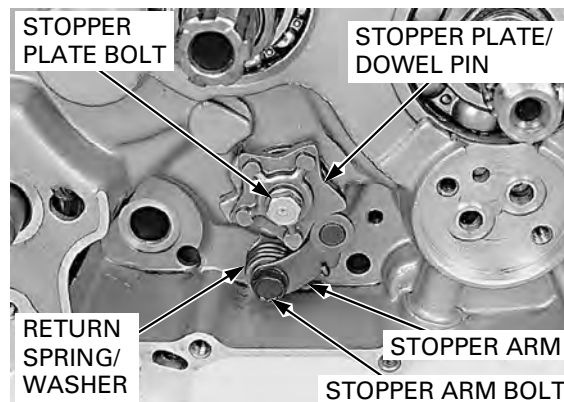

INSPECTION

Check the gearshift spindle for wear or bend.
Check the spindle plate for wear, damage or deformation.
Check the return spring for fatigue or damage.

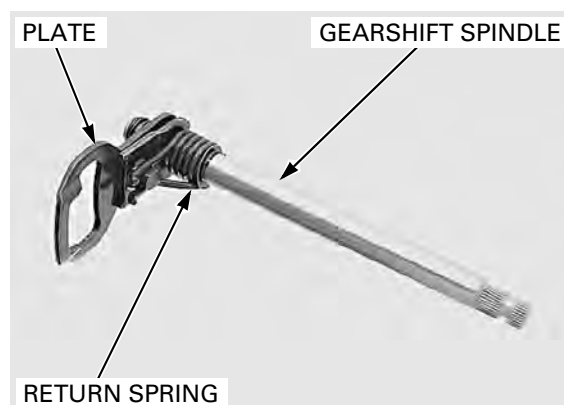

INSTALLATION

Install the dowel pin into the hole of the shift drum.
Install the return spring, washer, stopper arm and bolt, then tighten the bolt to the specified torque.

TORQUE: 12 N·m (1.2 kgf·m, 9 lbf·ft)

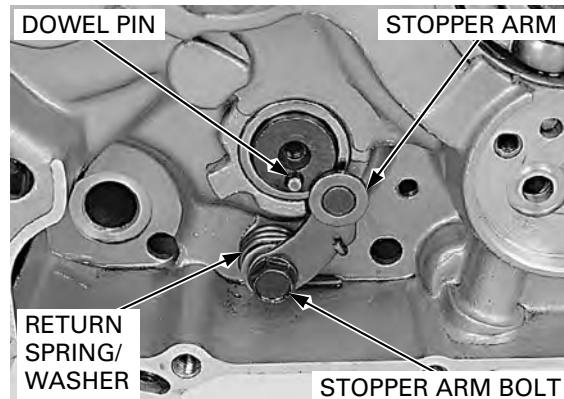

Hold the stopper arm using a screwdriver and install the stopper plate by aligning the pin hole with the dowel pin.

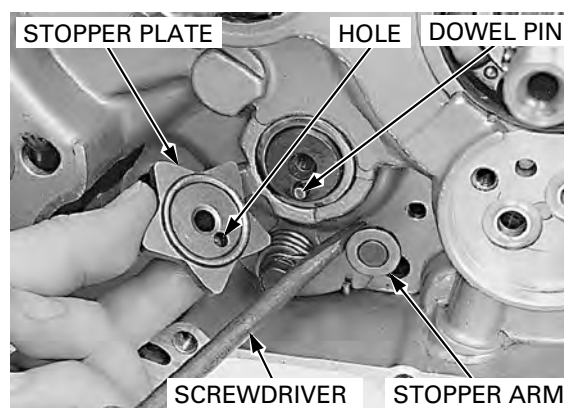

CLUTCH/GEARSHIFT LINKAGE

Install and tighten the stopper plate bolt.

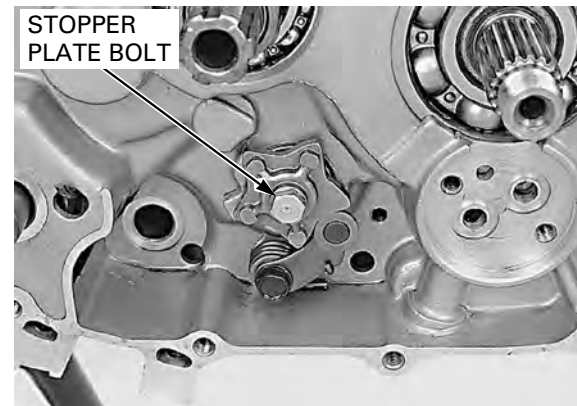

Install the washer onto the gearshift spindle.
Install the gearshift spindle with the spindle return spring attached to the lug on the crankcase.

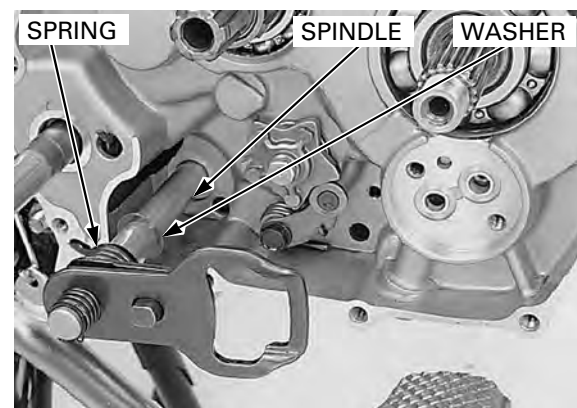

Install the gearshift pedal and tighten the bolt to the specified torque.

TORQUE: 12 N·m (1.2 kgf·m, 9 lbf·ft)

Install the following:

- Oil pump (page 4-9)
- Clutch (page 9-9)

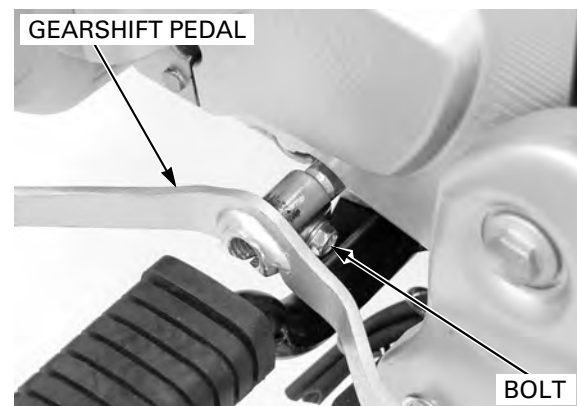

CLUTCH/GEARSHIFT LINKAGE

RIGHT CRANKCASE COVER INSTALLATION

Be careful not to damage the mating surfaces. Clean off any gasket material from the mating surfaces of the right crankcase and cover.
Install the dowel pins and new gasket.

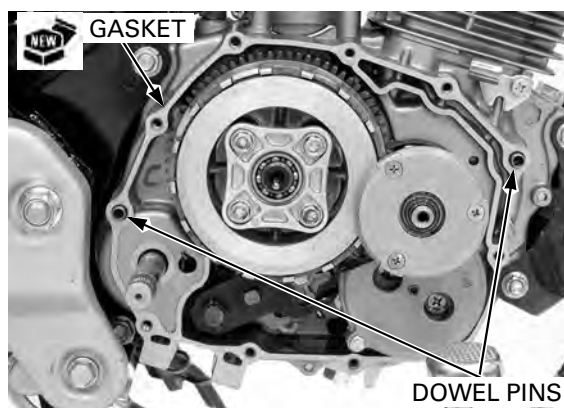

Install the right crankcase cover, and tighten the bolts in a crisscross pattern in 2 - 3 steps.

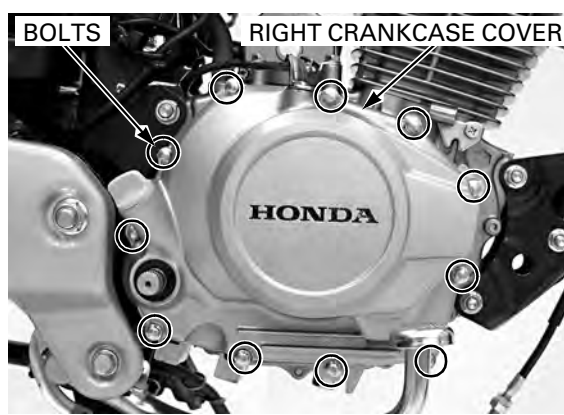

Install the kickstarter pedal and tighten the bolt to the specified torque.

TORQUE: 27 N·m (2.8 kgf·m, 20 lbf·ft)

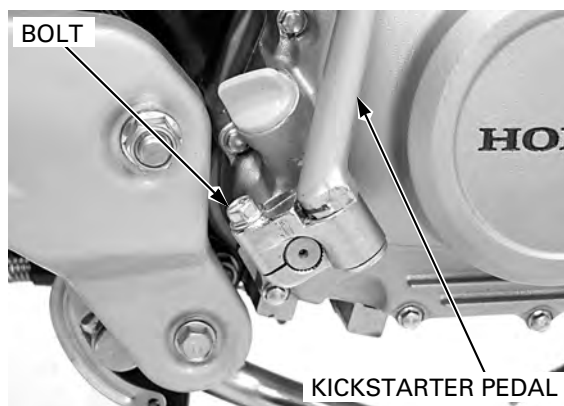

Connect the clutch cable end to the lifter arm and set the clutch cable to the stay.

Install the footpeg bar (page 2-8)
Install the muffler (page 2-9).
Adjust the clutch lever free play (page 3-18).
Fill the crankcase with the recommended engine oil (page 3-10).

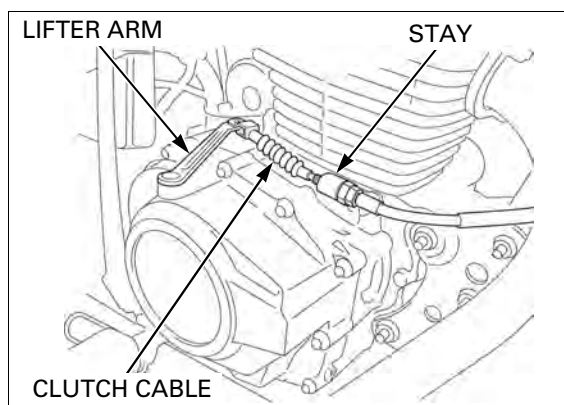

10. ALTERNATOR/STARTER CLUTCH

SYSTEM COMPONENTS	10-2	FLYWHEEL REMOVAL	10-6
SERVICE INFORMATION	10-3	STARTER CLUTCH	10-7
TROUBLESHOOTING	10-3	FLYWHEEL INSTALLATION.....	10-9
LEFT CRANKCASE COVER REMOVAL	10-4	LEFT CRANKCASE COVER INSTALLATION.....	10-11
STATOR/IGNITION PULSE GENERATOR..	10-5		

**ALTERNATOR/STARTER CLUTCH
SYSTEM COMPONENTS**

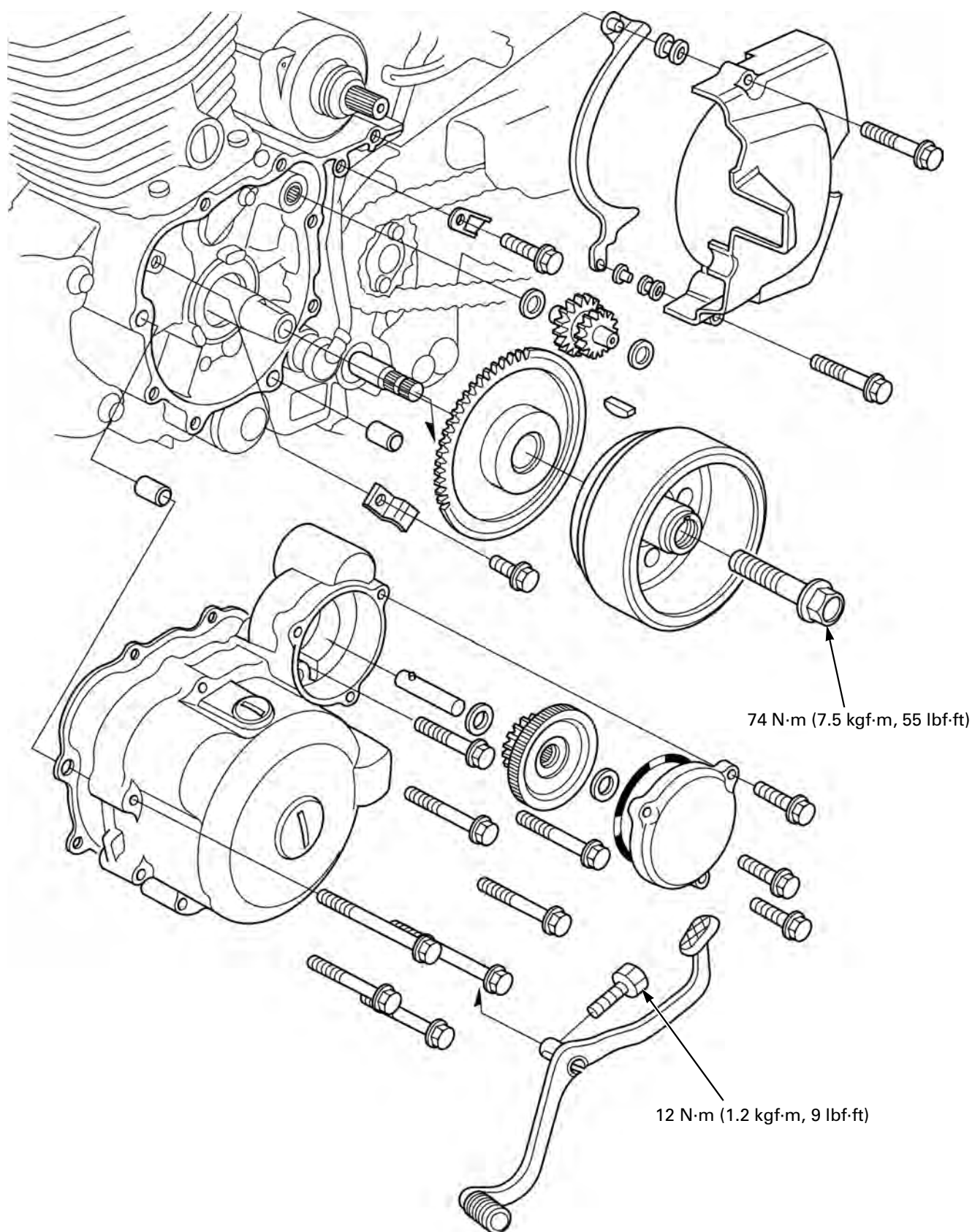

SERVICE INFORMATION

GENERAL

- This section covers the removal and installation of the alternator stator, flywheel and starter clutch. These services can be done with the engine installed in the frame.
- See page 10-5 for alternator stator inspection.
- See page 17-6 for starter motor servicing.

TORQUE VALUES

Starter clutch socket bolt	16 N·m (1.6 kgf·m, 12 lbf·ft)	Apply a locking agent to the threads.
Flywheel bolt	74 N·m (7.5 kgf·m, 55 lbf·ft)	Apply engine oil to the threads and seating surface.
Ignition pulse generator mounting bolt	5 N·m (0.5 kgf·m, 3.7 lbf·ft)	Apply a locking agent to the threads.

TOOLS

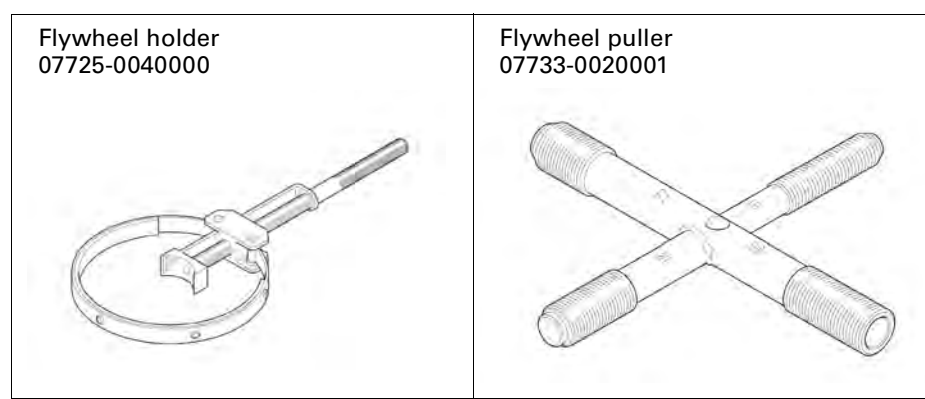

TROUBLESHOOTING

Starter motor turns, but engine does not start

- Faulty starter clutch
- Damaged reduction gear/shaft

ALTERNATOR/STARTER CLUTCH

LEFT CRANKCASE COVER REMOVAL

Remove the left side cover (page 2-3).

Disconnect the following:

- Yellow and Pink alternator wire connectors
- Black/Red exciter coil wire connector
- Green/White and Blue/Yellow ignition pulse generator wire connectors

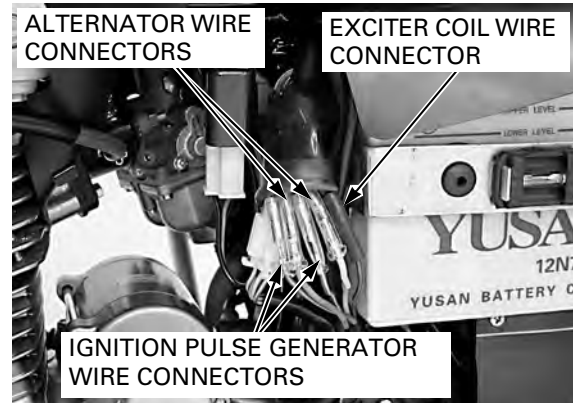

Remove the left crankcase rear cover (page 6-4).

Remove the bolts and starter reduction gear cover. Remove the bolt and wire guide plate.

Release the alternator/ignition pulse generator wire from the clamp.

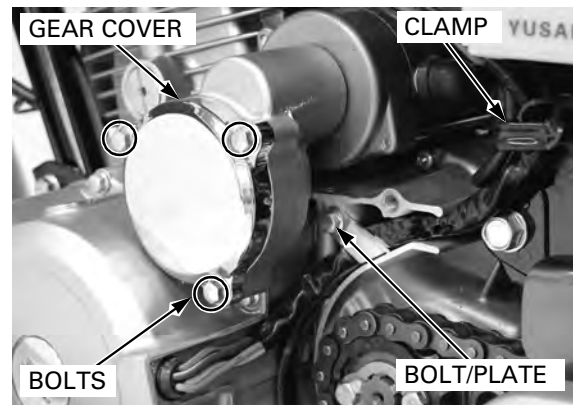

Remove the reduction gear shaft and starter reduction gear.

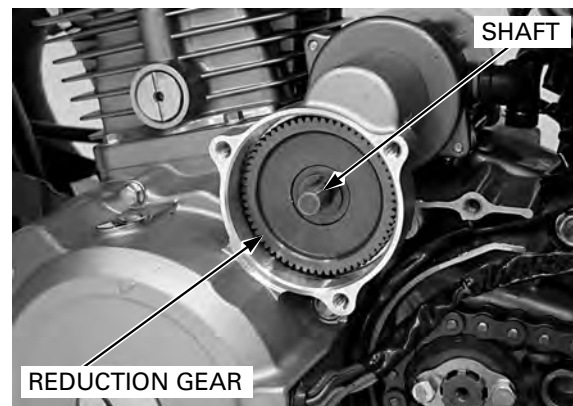

Loosen the left crankcase cover bolts in a crisscross pattern in several steps.

The left crankcase cover (stator) is magnetically attached to the fly-wheel, be careful when removing the cover.

Remove the left crankcase cover bolts and cover.

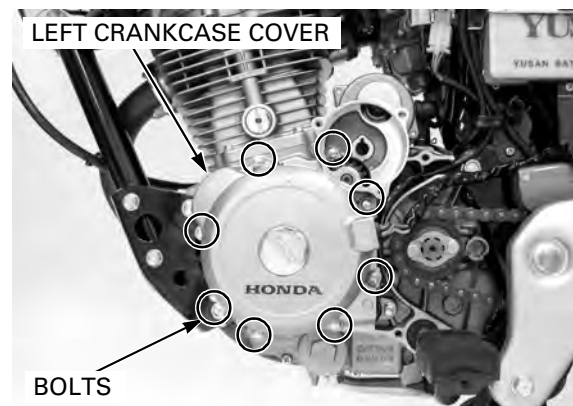

ALTERNATOR/STARTER CLUTCH

Remove the dowel pins and gasket.

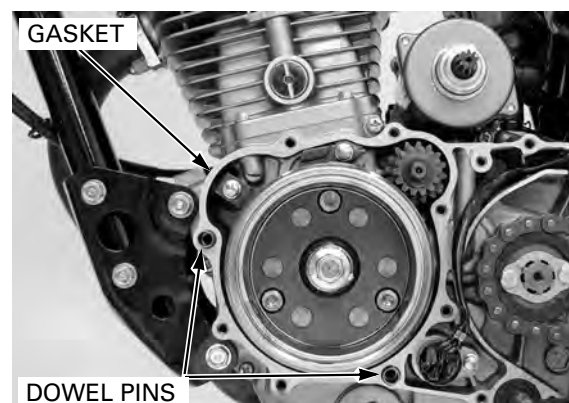

STATOR/IGNITION PULSE GENERATOR

REMOVAL

Remove the left crankcase cover (page 10-4).

Remove the following:

- Grommet
- Two mounting bolts
- Ignition pulse generator
- Three socket bolts
- Stator

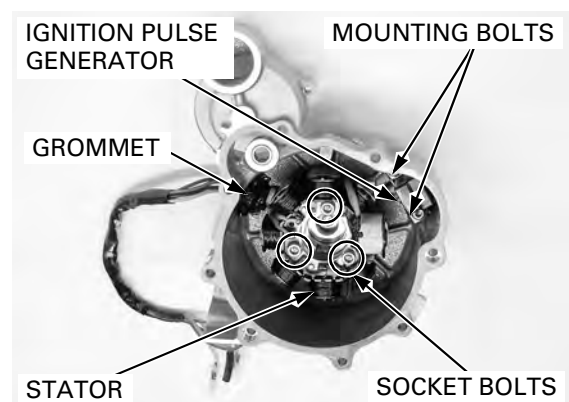

INSTALLATION

Install the stator.

Install the three socket bolts and tighten them.

Apply liquid sealant to the wire grommet seating surface and install the grommet into the groove.

Install the ignition pulse generator.

Apply a locking agent to the two mounting bolt threads.

Install the mounting bolts and tighten them to the specified torque.

TORQUE: 5 N·m (0.5 kgf·m, 3.7 lbf·ft)

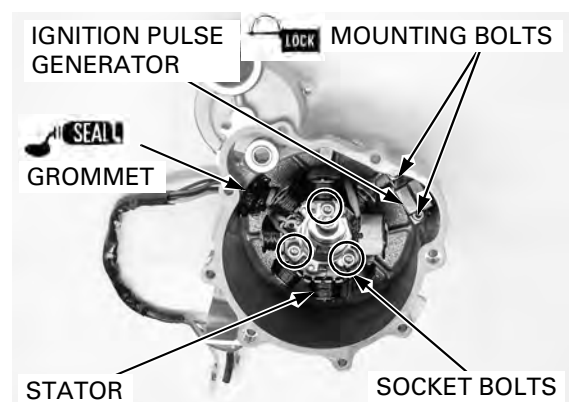

ALTERNATOR/STARTER CLUTCH

FLYWHEEL REMOVAL

Remove the left crankcase cover (page 10-4).
Remove the starter idle gear, shaft and washers.

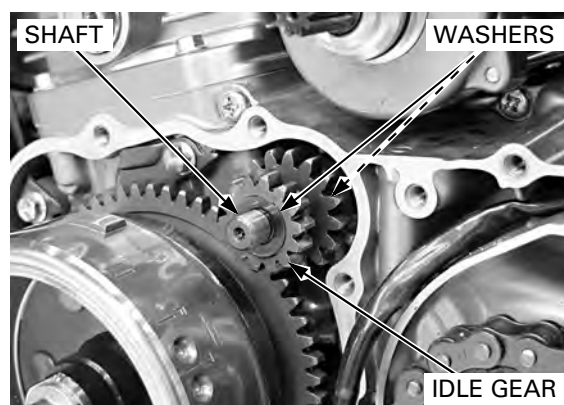

Remove the bolt and stopper plate.

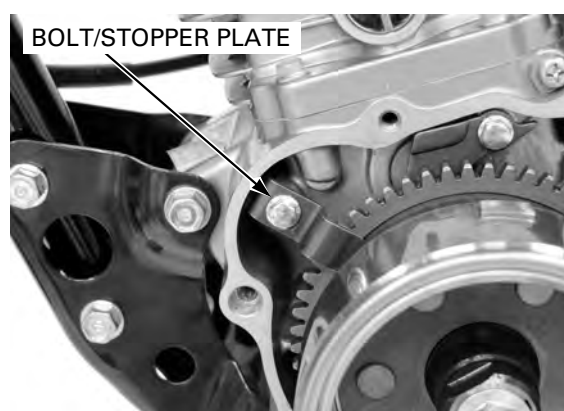

Hold the flywheel with the flywheel holder and remove the flywheel bolt.

TOOL:
Flywheel holder 07725-004000

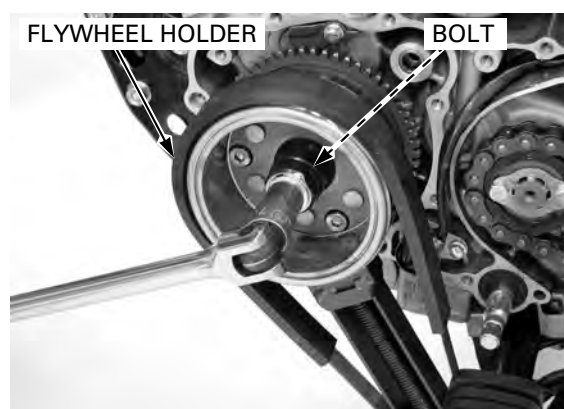

Remove the flywheel using the flywheel puller.

TOOL:
Flywheel puller 07733-002001

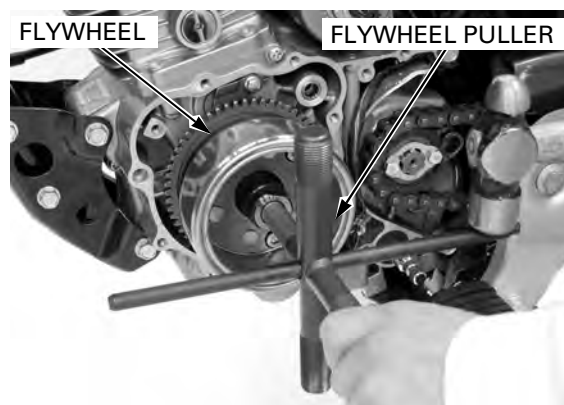

ALTERNATOR/STARTER CLUTCH

When removing the woodruff key, be careful not to damage the key groove and crankshaft.

Remove the woodruff key.



STARTER CLUTCH

DISASSEMBLY

Remove the flywheel (page 10-6).

Remove the starter driven gear from the flywheel while turning the driven gear counterclockwise.

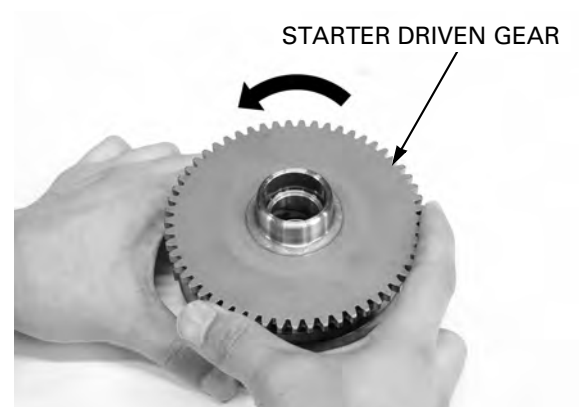

Remove the starter clutch bolts while holding the flywheel with a flywheel holder.

TOOL:

Flywheel holder 07725-0040000

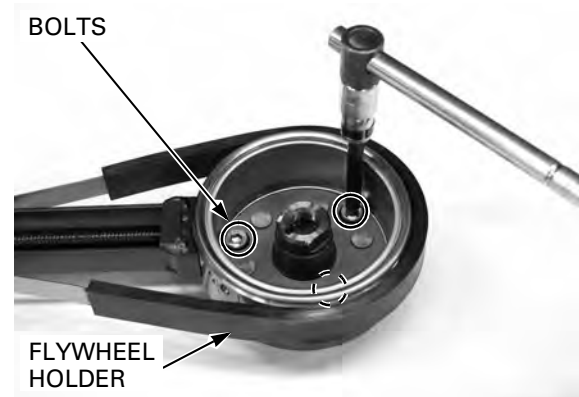

Remove the starter clutch assembly from the flywheel.

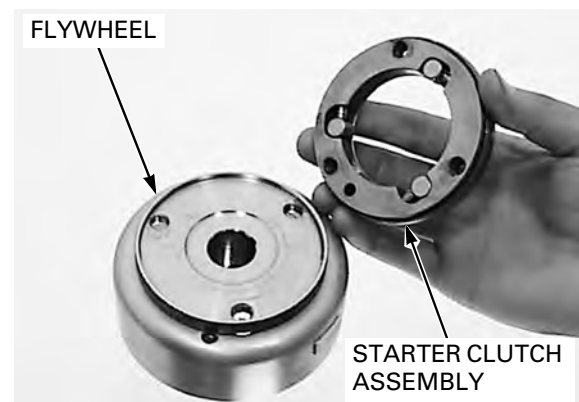

ALTERNATOR/STARTER CLUTCH

INSPECTION

Check the spring for fatigue or damage.

Check the spring guides and rollers for wear or damage.

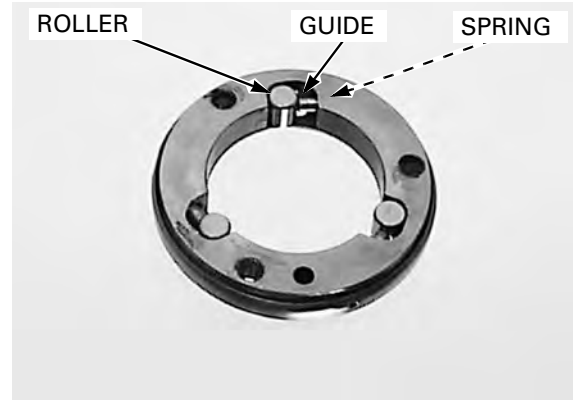

ASSEMBLY

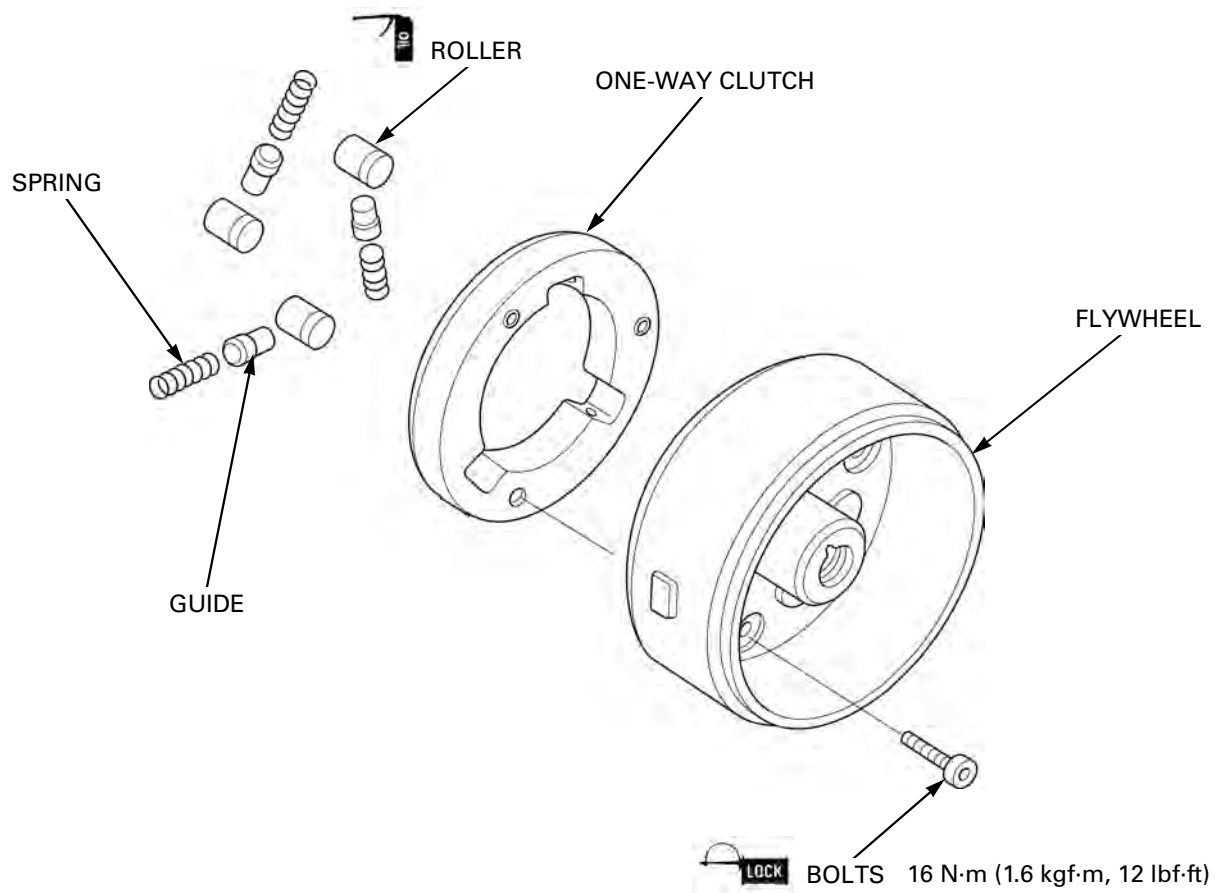

Clean the starter clutch assembly and apply engine oil to the roller.



ALTERNATOR/STARTER CLUTCH

Install the starter clutch assembly to the flywheel, aligning the bolt hole of cover, starter clutch and flywheel.

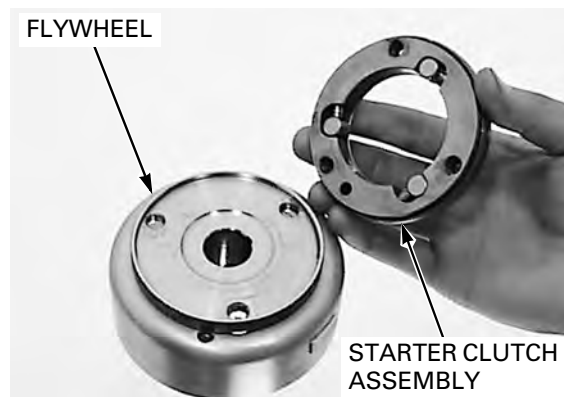

Hold the flywheel using the flywheel holder.

TOOL:
Flywheel holder 07725-004000

Clean and apply a locking agent to the starter clutch bolt threads.
Install and tighten the starter clutch socket bolts to the specified torque.

TORQUE: 16 N·m (1.6 kgf·m, 12 lbf·ft)

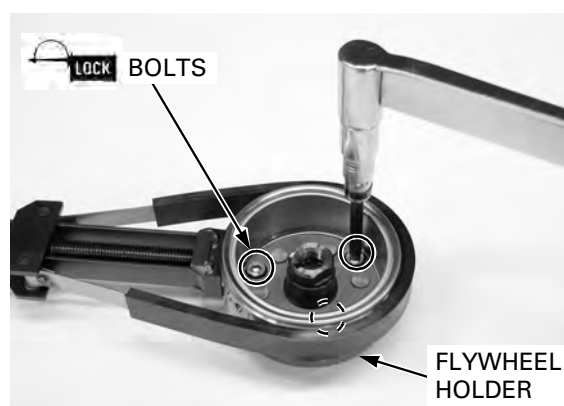

Apply clean engine oil to the starter driven gear teeth.

Install the starter driven gear to the flywheel while turning the driven gear counterclockwise.

Make sure that the starter driven gear turns counterclockwise smoothly and does not turn clockwise.

Install the flywheel (page 10-9).

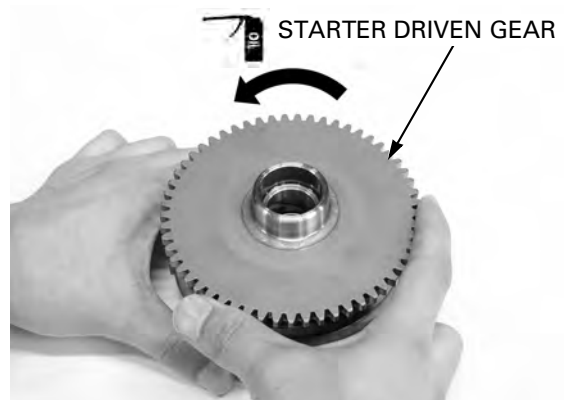

FLYWHEEL INSTALLATION

When installing the woodruff key, be careful not to damage the key groove and crankshaft.

Clean any oil from the crankshaft taper.

Install the woodruff key.



ALTERNATOR/STARTER CLUTCH

Install the flywheel, aligning the woodruff key on the crankshaft with flywheel keyway.

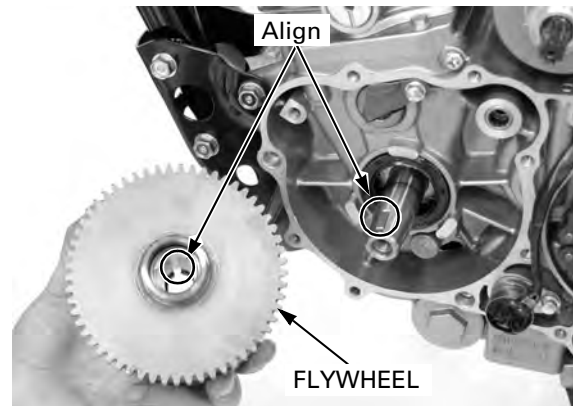

Apply clean engine oil to the flywheel bolt threads and seating surface.

Install the washer and bolt.

Hold the flywheel with the flywheel holder, tighten the bolt to the specified torque.

TOOL:

Flywheel holder 07725-0040000

TORQUE: 74 N·m (7.5 kgf·m, 55 lbf·ft)

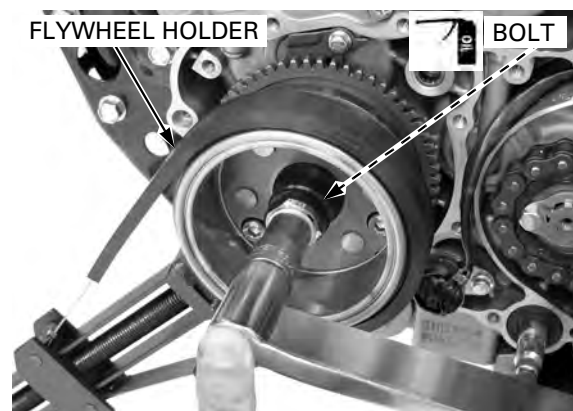

Install the stopper plate and tighten the bolt.

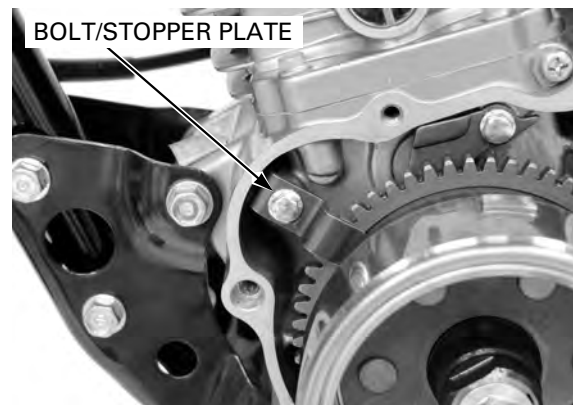

Apply clean engine oil to the starter idle gear and shaft.

Install the starter idle gear, shaft and washers.

Install the left crankcase cover (page 10-11).

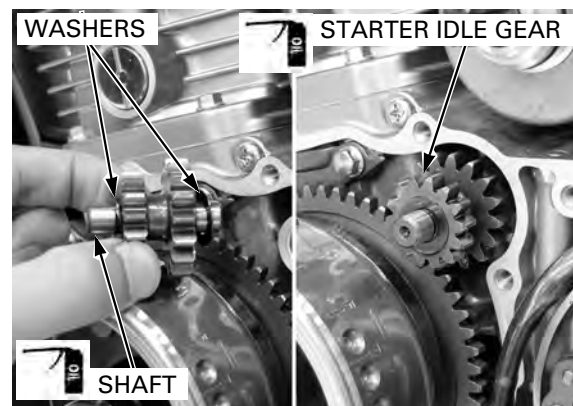

LEFT CRANKCASE COVER INSTALLATION

Apply clean engine oil to the new O-ring and install it to the starter motor.

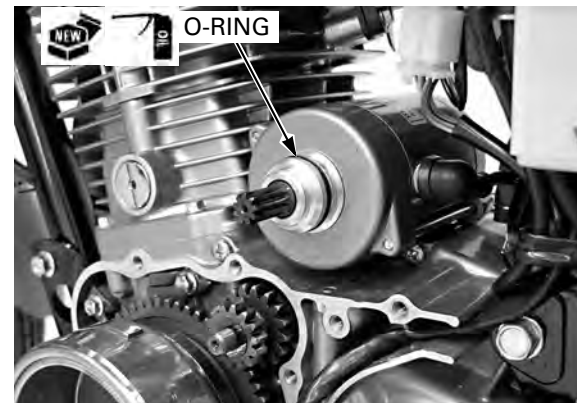

Install the new gasket and dowel pins.

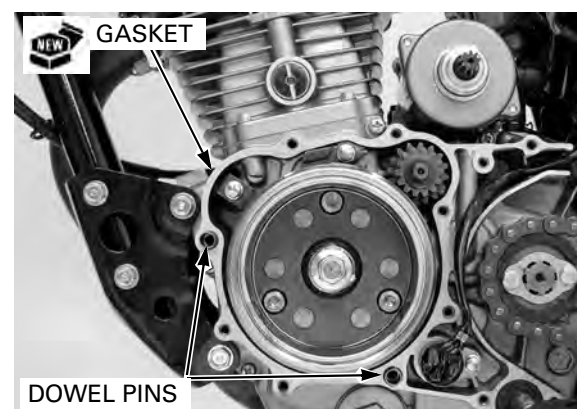

The left crankcase cover (stator) is magnetically attached to the flywheel, be careful when installing.

Install the left crankcase cover and tighten the bolts.

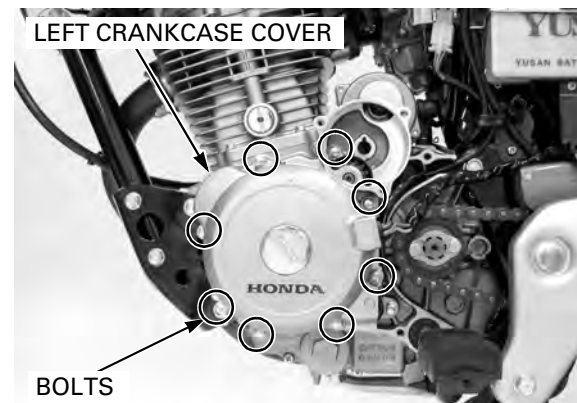

Apply clean engine oil to the starter reduction gear and shaft.

Install the reduction gear shaft and starter reduction gear by aligning the shaft boss with the crankcase cover groove.

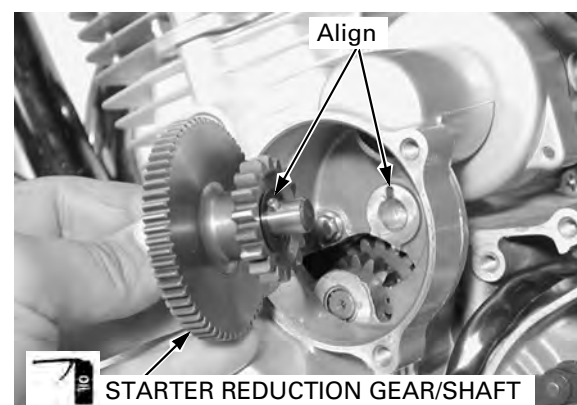

ALTERNATOR/STARTER CLUTCH

Apply clean engine oil to the new O-ring and install it to the starter reduction gear cover.



Install the starter reduction gear cover to the left crankcase cover.

Install and tighten the gear cover bolts.

Route the alternator/ignition pulse generator wire in the left crankcase groove and install the wire guide plate and the bolt.

Set the alternator/ignition pulse generator wire to the clamp.

Install the left crankcase rear cover (page 6-5).

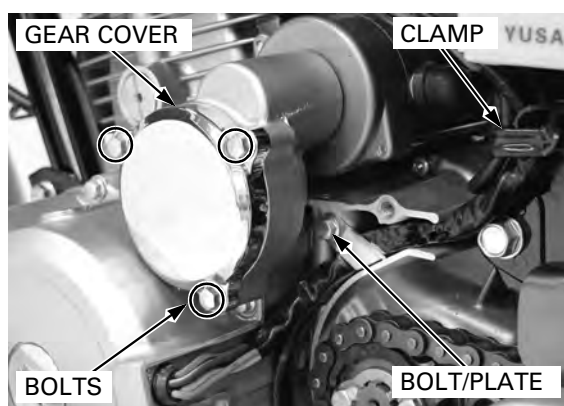

Connect the following:

- Yellow and Pink alternator wire connectors
- Black/Red exciter coil wire connector
- Green/White and Blue/Yellow ignition pulse generator wire connectors

Install the left side cover (page 2-3).

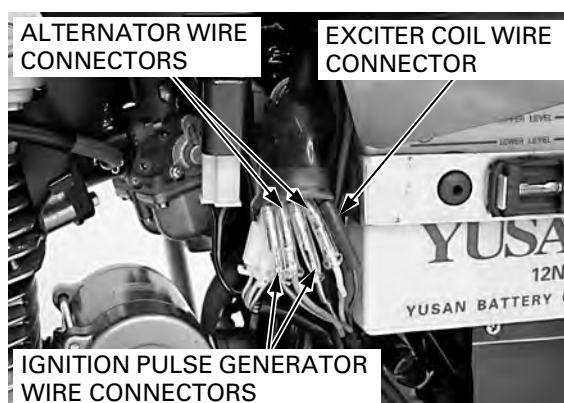

11. CRANKSHAFT/TRANSMISSION/KICKSTARTER

SYSTEM COMPONENTS	11-2	CRANKSHAFT.....	11-7
SERVICE INFORMATION	11-3	TRANSMISSION.....	11-8
TROUBLESHOOTING	11-5	KICKSTARTER	11-14
CRANKCASE SEPARATION.....	11-6	CRANKCASE ASSEMBLY	11-19

**CRANKSHAFT/TRANSMISSION/KICKSTARTER
SYSTEM COMPONENTS**

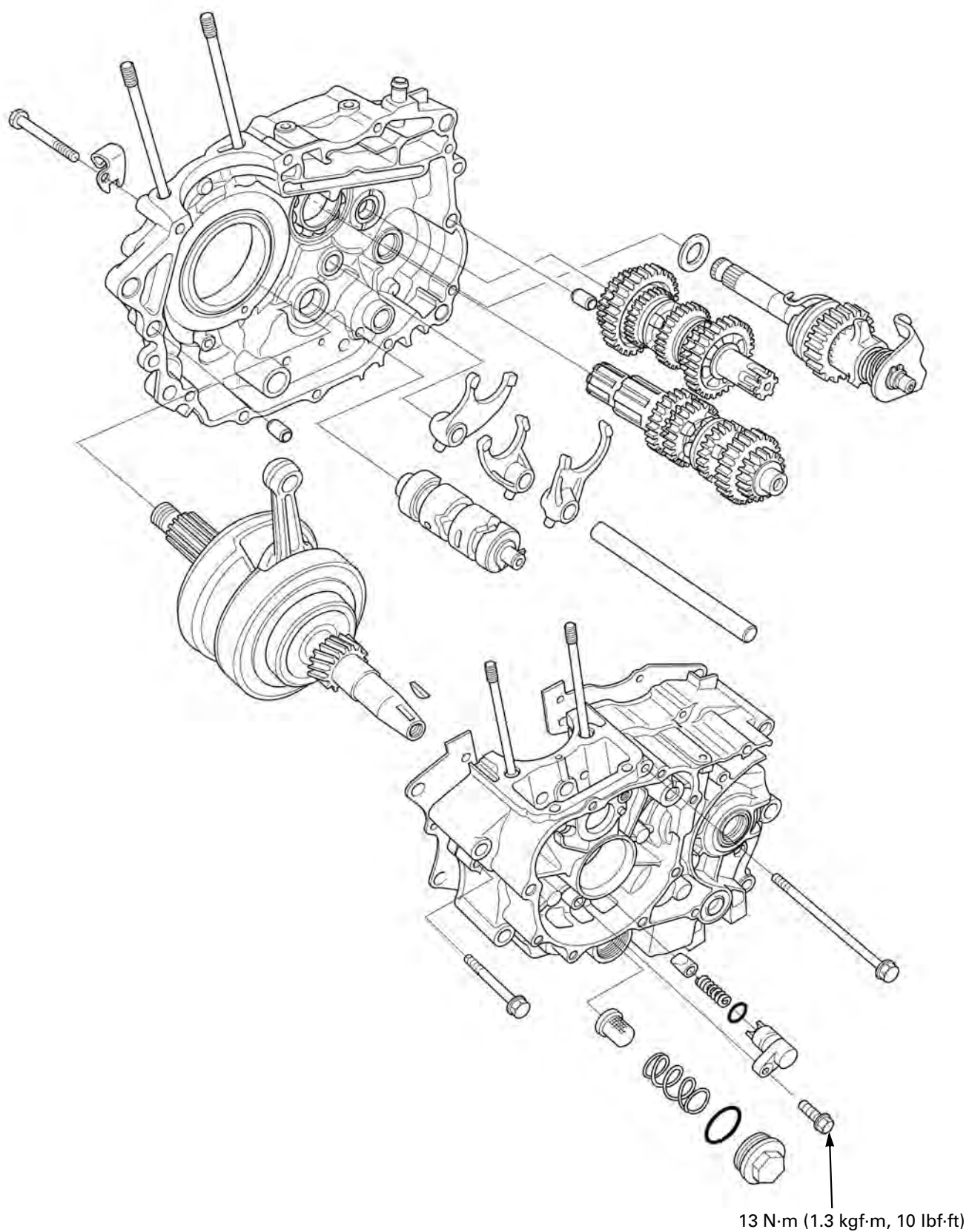

CRANKSHAFT/TRANSMISSION/KICKSTARTER

SERVICE INFORMATION

GENERAL

- The crankcase halves must be separated to service the transmission, crankshaft and kickstarter. To service these parts, the engine must be removed from the frame (page 6-6).
- Be careful not to damage the crankcase mating surfaces when servicing.

SPECIFICATIONS

		Unit: mm (in)		
ITEM		STANDARD	SERVICE LIMIT	
Crankshaft	Connecting rod side clearance	0.10 – 0.30 (0.004 – 0.012)	0.5 (0.02)	
	Connecting rod radial clearance	0.008 – 0.018 (0.0003 – 0.0007)	0.05 (0.002)	
	Runout	–	0.02 (0.001)	
Transmission	Gear I.D.	M3, M5	20.020 – 20.041 (0.7882 – 0.7890)	20.07 (0.790)
		C1	19.520 – 19.541 (0.7685 – 0.7693)	19.57 (0.770)
		C2	22.000 – 22.021 (0.8661 – 0.8670)	22.05 (0.868)
		C4	20.020 – 20.041 (0.7882 – 0.7890)	20.07 (0.790)
	Bushing O.D.	C1	19.479 – 19.500 (0.7669 – 0.7677)	19.43 (0.765)
	Bushing I.D.	C1	16.516 – 16.534 (0.6502 – 0.6509)	16.60 (0.654)
	Gear-to-bushing clearance	C1	0.020 – 0.062 (0.0008 – 0.0024)	0.10 (0.004)
	Mainshaft O.D.	M3	19.959 – 19.980 (0.7858 – 0.7866)	19.91 (0.784)
	Countershaft O.D.	C1	16.466 – 16.484 (0.6483 – 0.6490)	16.41 (0.646)
		C2	21.959 – 21.980 (0.8645 – 0.8654)	21.91 (0.863)
		C4	19.959 – 19.980 (0.7858 – 0.7866)	19.91 (0.784)
	Gear-to-shaft clearance	M3	0.040 – 0.082 (0.0016 – 0.0032)	0.10 (0.004)
		C2	0.020 – 0.062 (0.0008 – 0.0024)	0.10 (0.004)
C4		0.040 – 0.082 (0.0016 – 0.0032)	0.10 (0.004)	
Bushing-to-shaft clearance	C1	0.032 – 0.068 (0.0013 – 0.0027)	0.10 (0.004)	
Shift fork	I.D.	12.000 – 12.018 (0.4724 – 0.4731)	12.05 (0.474)	
	Claw thickness	4.93 – 5.00 (0.194 – 0.197)	4.50 (0.177)	
	Shaft O.D.	11.976 – 11.994 (0.4715 – 0.4722)	11.96 (0.471)	
Kickstarter	Pinion gear I.D.	20.000 – 20.021 (0.7874 – 0.7882)	20.05 (0.789)	
	Spindle O.D.	19.966 – 19.984 (0.7861 – 0.7868)	19.90 (0.783)	









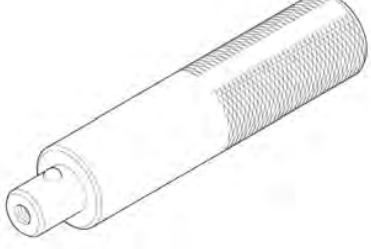

TORQUE VALUE

Push plug holder bolt

13 N·m (1.3 kgf·m, 10 lbf·ft)

CRANKSHAFT/TRANSMISSION/KICKSTARTER

TOOLS

<p>Bearing remover shaft, 15 mm 07936-KC10100</p> 	<p>Bearing remover head, 15 mm 07936-KC10200</p> 	<p>Remover weight 07741-0010201</p> 
<p>Driver 07749-0010000</p> 	<p>Attachment, 28 x 30 mm 07946-1870100</p> 	<p>Attachment, 32 x 35 mm 07746-0010100</p> 
<p>Attachment, 42 x 47 mm 07746-0010300</p> 	<p>Attachment, 52 x 55 mm 07746-0010400</p> 	<p>Pilot, 15 mm 07746-0040300</p> 
<p>Pilot, 20 mm 07746-0040500</p> 	<p>Pilot, 30 mm 07746-0040700</p> 	

TROUBLESHOOTING

Hard to shift

- Incorrect clutch adjustment
- Damaged shift drum cam groove
- Bent shift fork
- Bent shift fork shaft

Transmission jumps out of gear

- Worn gear engagement dogs or slots
- Damaged or bent shift fork
- Bent shift fork shaft
- Damaged shift drum stopper arm
- Broken shift linkage return spring
- Damaged shift drum grooves

Excessive noise

- Worn connecting rod big end bearing
- Bent connecting rod
- Worn crankshaft main journal bearing

CRANKSHAFT/TRANSMISSION/KICKSTARTER

CRANKCASE SEPARATION

Remove the following:

- Engine (page 6-6)
- Footpeg bar (page 2-8)
- Starter motor (page 17-6)
- Cylinder head (page 7-12)
- Cylinder (page 8-4)
- Piston (page 8-10)
- Oil pump (page 4-5)
- Clutch (page 9-6)
- Gearshift linkage (page 9-11)
- Flywheel (page 10-6)
- Primary drive gear (page 9-7)
- Woodruff key (page 10-7)

Remove the push plug holder bolt and push plug holder.

Remove the clutch cable stay bolt and clutch cable stay.

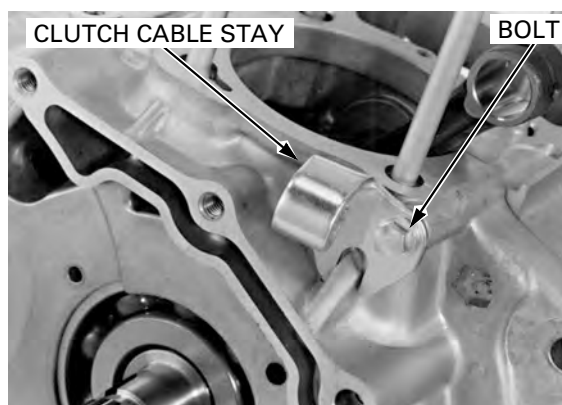
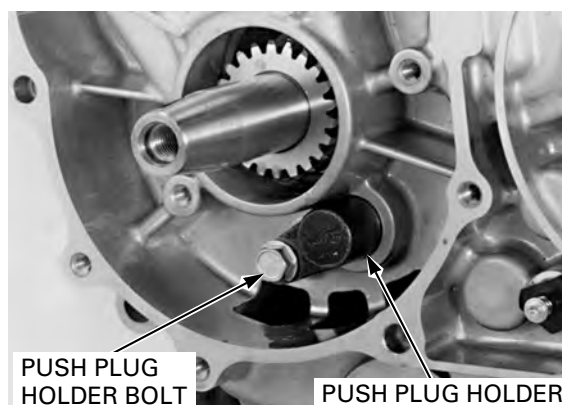

Loosen the left crankcase bolts in crisscross pattern in 2 or 3 steps and remove them.

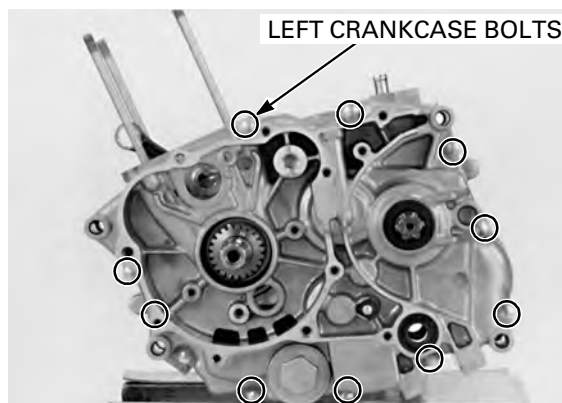

Do not divide the crankcase with a screwdriver.

Place the right crankcase down; separate the left and right crankcase into halves.

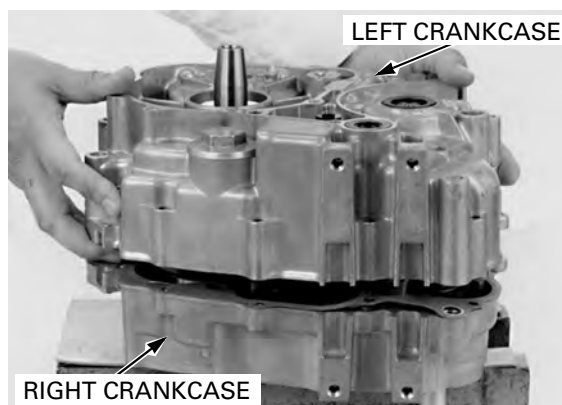

CRANKSHAFT/TRANSMISSION/KICKSTARTER

Remove the gasket and dowel pins.

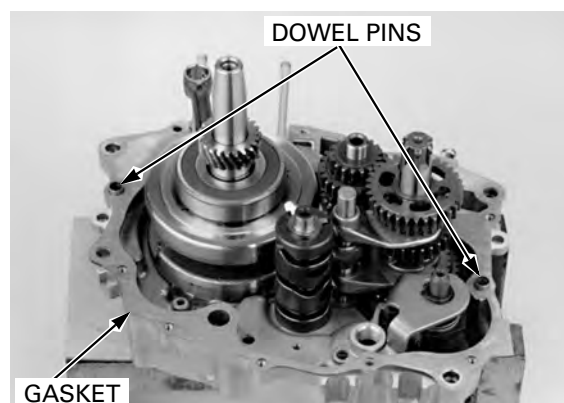

CRANKSHAFT

Remove the crankshaft from the crankcase.

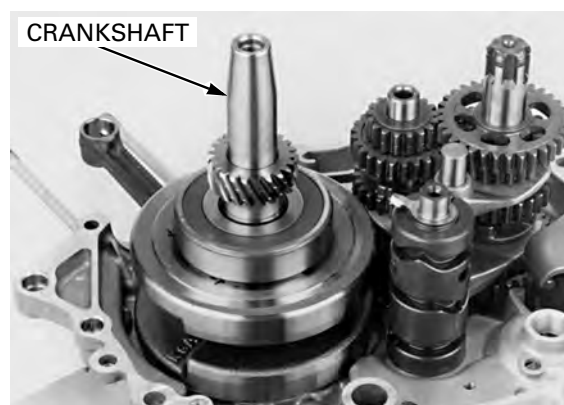

INSPECTION

Measure the side clearance at the connecting rod big end with a feeler gauge.

SERVICE LIMIT: 0.5 mm (0.02 in)

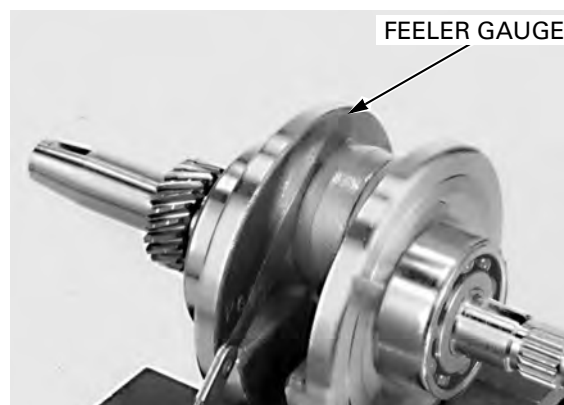

Measure the radial clearance of the connecting rod big end.

SERVICE LIMIT: 0.05 mm (0.002 in)

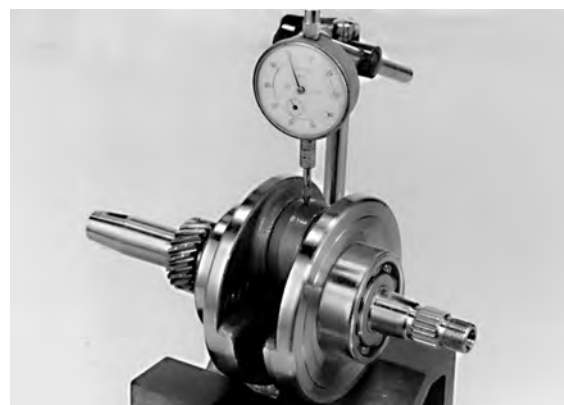

CRANKSHAFT/TRANSMISSION/KICKSTARTER

Place the crankshaft on a stand or V-blocks and measure the runout with a dial indicator.

SERVICE LIMIT: 0.02 mm (0.001 in)

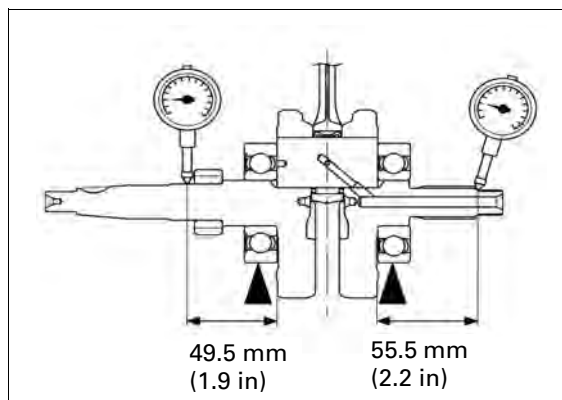

CRANKSHAFT BEARING INSPECTION

Turn the outer race of each bearing with your finger. The bearing should turn smoothly and quietly. Also check that each bearing inner race fits tightly to the crankshaft.

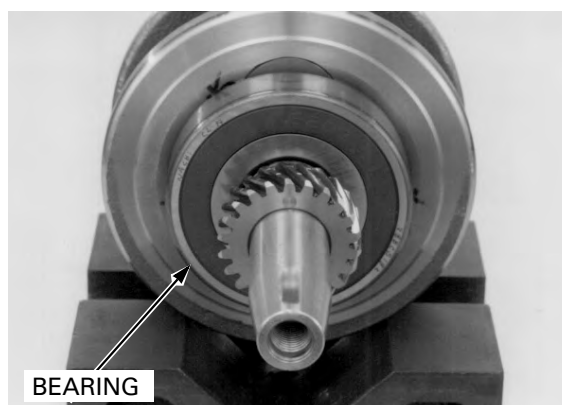

TIMING DRIVE GEAR INSTALLATION

Check the timing drive gear for wear or damage.

If you replace the timing drive gear, align the timing mark on the timing drive gear with the center of woodruff key groove as shown.

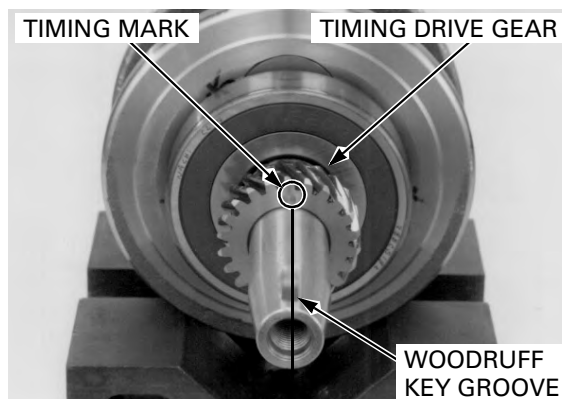

TRANSMISSION

DISASSEMBLY

Remove the shift fork shaft.

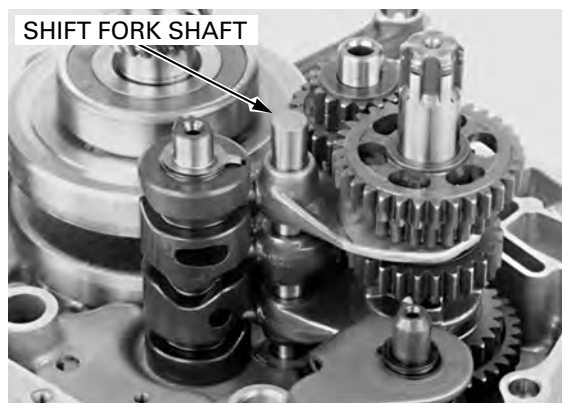

CRANKSHAFT/TRANSMISSION/KICKSTARTER

Remove the shift drum.
Remove the shift forks.

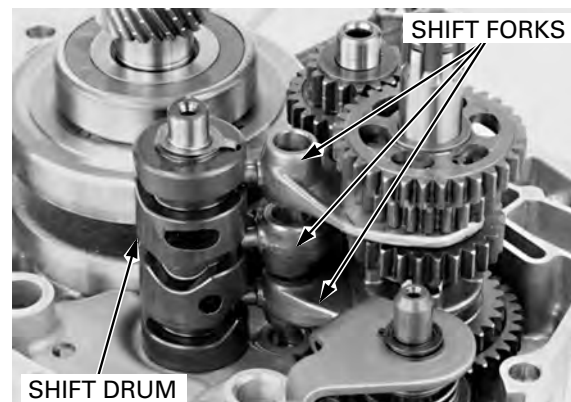

Remove the mainshaft and countershaft as an assembly from the crankcase.
Disassemble the mainshaft and countershaft.

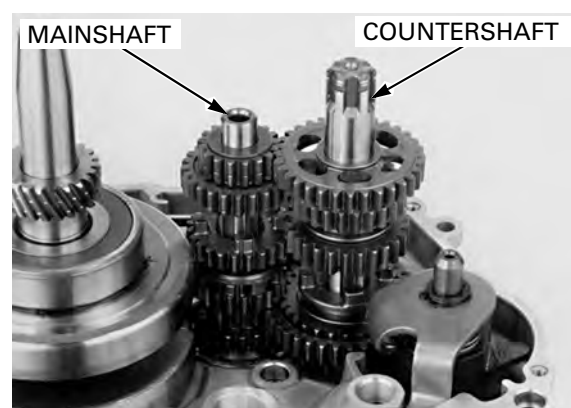

INSPECTION

Check the shift fork for wear, bending or damage.
Measure the shift fork I.D.

SERVICE LIMIT: 12.05 mm (0.474 in)

Measure the shift fork claw thickness.

SERVICE LIMIT: 4.50 mm (0.177 in)

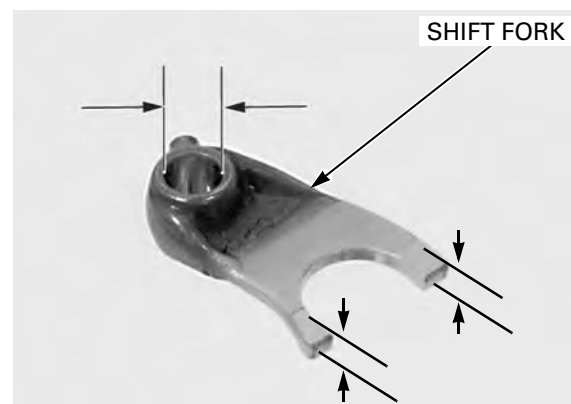

Check the shift fork shaft for bending wear or damage.
Measure the shift fork shaft O.D.

SERVICE LIMIT: 11.96 mm (0.471 in)

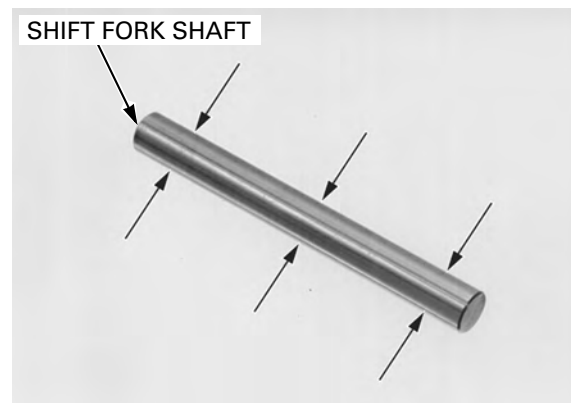

CRANKSHAFT/TRANSMISSION/KICKSTARTER

Inspect the shift drum grooves.
Replace the shift drum if the grooves are damaged or excessively worn.



TRANSMISSION INSPECTION

Check the gear dogs, dog holes and teeth for abnormal wear or lack of lubrication.
Measure the I.D. of each gear.

SERVICE LIMITS:

M3, M5:	20.07 mm (0.790 in)
C1:	19.57 mm (0.770 in)
C2:	22.05 mm (0.868 in)
C4:	20.07 mm (0.790 in)

Measure the O.D. and I.D. of C1 gear bushing.

SERVICE LIMITS:

C1, O.D.:	19.43 mm (0.765 in)
C1, I.D.:	16.60 mm (0.654 in)

Measure the O.D. of both the mainshaft and the countershaft.

SERVICE LIMITS:

At M3 gear:	19.91 mm (0.784 in)
At C1 gear:	16.41 mm (0.646 in)
At C2 gear:	21.91 mm (0.863 in)
At C4 gear:	19.91 mm (0.784 in)

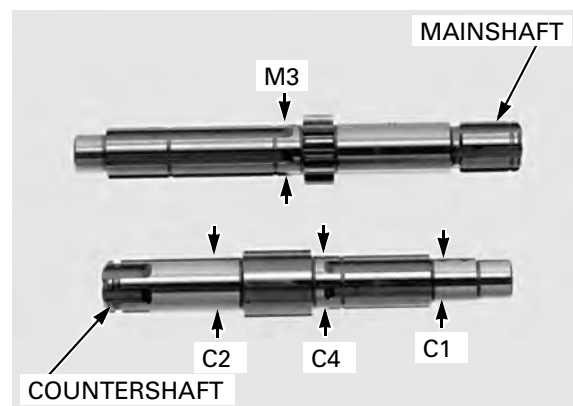
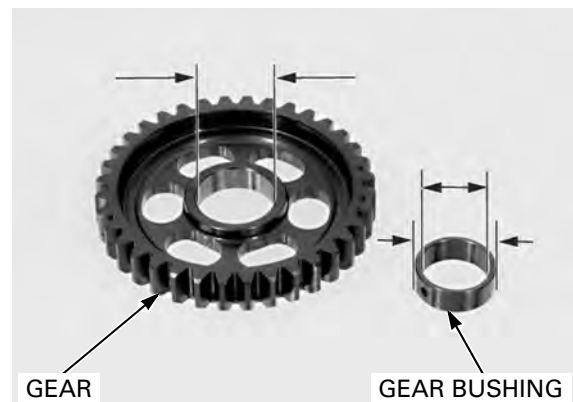

TRANSMISSION BEARING REPLACEMENT

Turn the inner race of each bearing with your finger.
The bearings should turn smoothly and quietly.
Also check that the bearing outer race fits tightly in the crankcase.

Remove and discard the bearings if the races do not turn smoothly, quietly, or if they fit loosely in the crankcase.

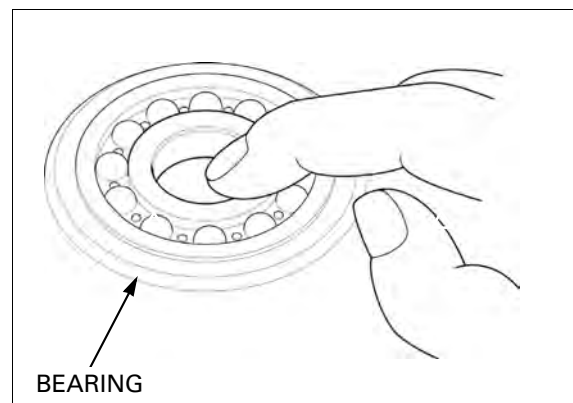

CRANKSHAFT/TRANSMISSION/KICKSTARTER

Remove the countershaft oil seal and gearshift spindle oil seal.

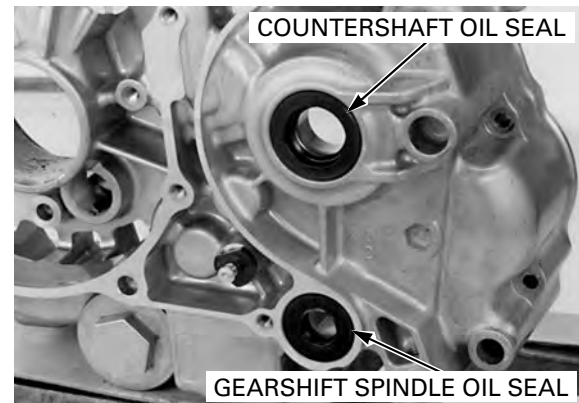

Remove the mainshaft bearing from the right crankcase.
Remove the countershaft needle bearing from the right crankcase by using special tools.

TOOLS:

Bearing remover shaft, 15 mm 07936-KC10100
Bearing remover head, 15 mm 07936-KC10200
Remover weight 07741-0010201

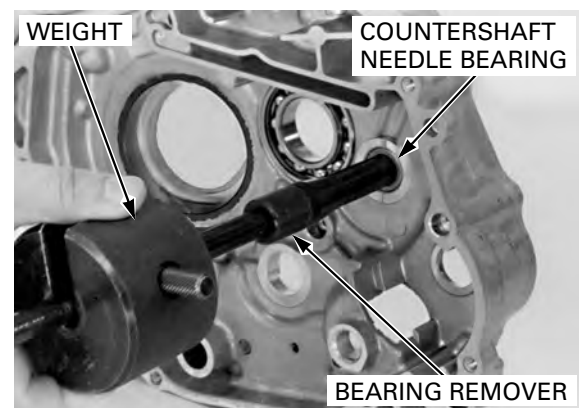

Remove the countershaft bearing from the left crankcase.
Remove the mainshaft bearing from the left crankcase by using special tools.

TOOLS:

Bearing remover shaft, 15 mm 07936-KC10100
Bearing remover head, 15 mm 07936-KC10200
Remover weight 07741-0010201

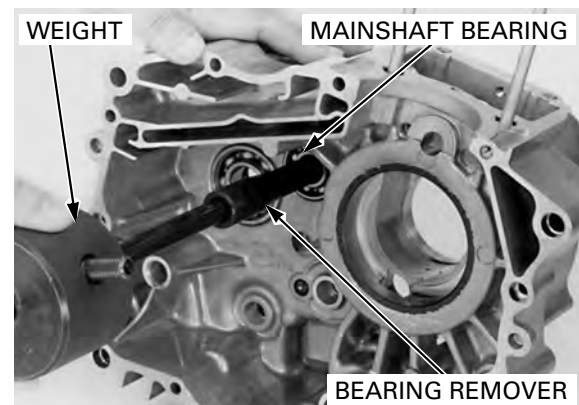

Apply engine oil to new bearings.
Install the new bearing by using the following tools.

TOOLS:

Right crankcase mainshaft bearing:

Driver 07749-0010000
Attachment, 52 x 55 mm 07746-0010400
Pilot, 30 mm 07746-0040700

Right crankcase countershaft needle bearing:

Driver 07749-0010000
Attachment, 28 x 30 mm 07946-1870100
Pilot, 15 mm 07746-0040300

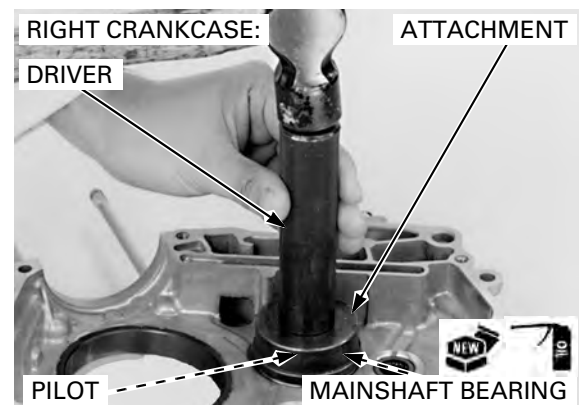

CRANKSHAFT/TRANSMISSION/KICKSTARTER

Apply engine oil to new bearings.
Install the new bearing by using the following tools.

TOOLS:

Left crankcase mainshaft bearing:

Driver 07749-0010000
Attachment, 32 x 35 mm 07746-0010100
Pilot, 15 mm 07746-0040300

Left crankcase countershaft bearing:

Driver 07749-0010000
Attachment, 42 x 47 mm 07746-0010300
Pilot, 20 mm 07746-0040500

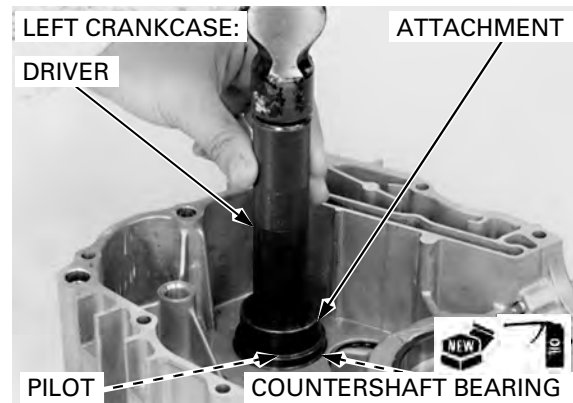

Apply engine oil to the new countershaft oil seal lip and new gearshift spindle oil seal lip, then install them to the left crankcase.

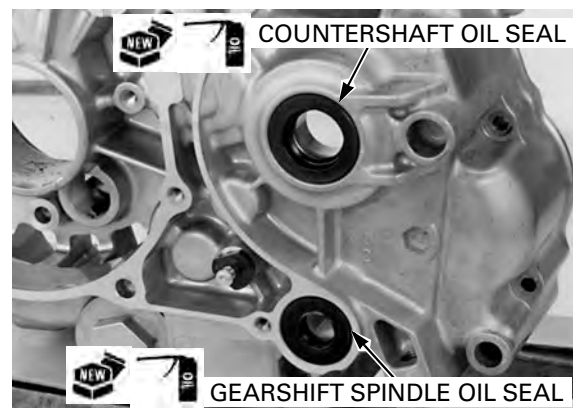

ASSEMBLY

MAINSHAFT:

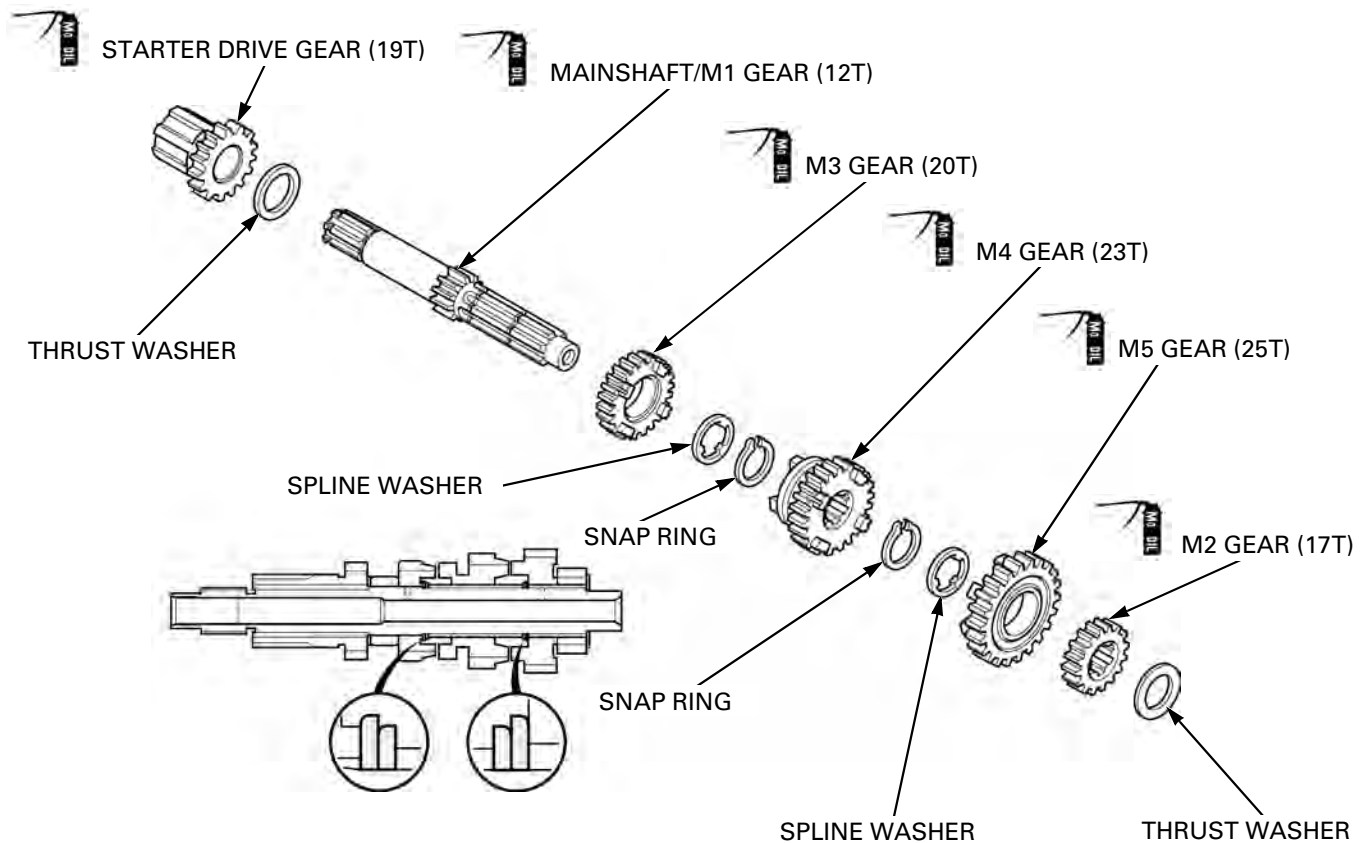

CRANKSHAFT/TRANSMISSION/KICKSTARTER

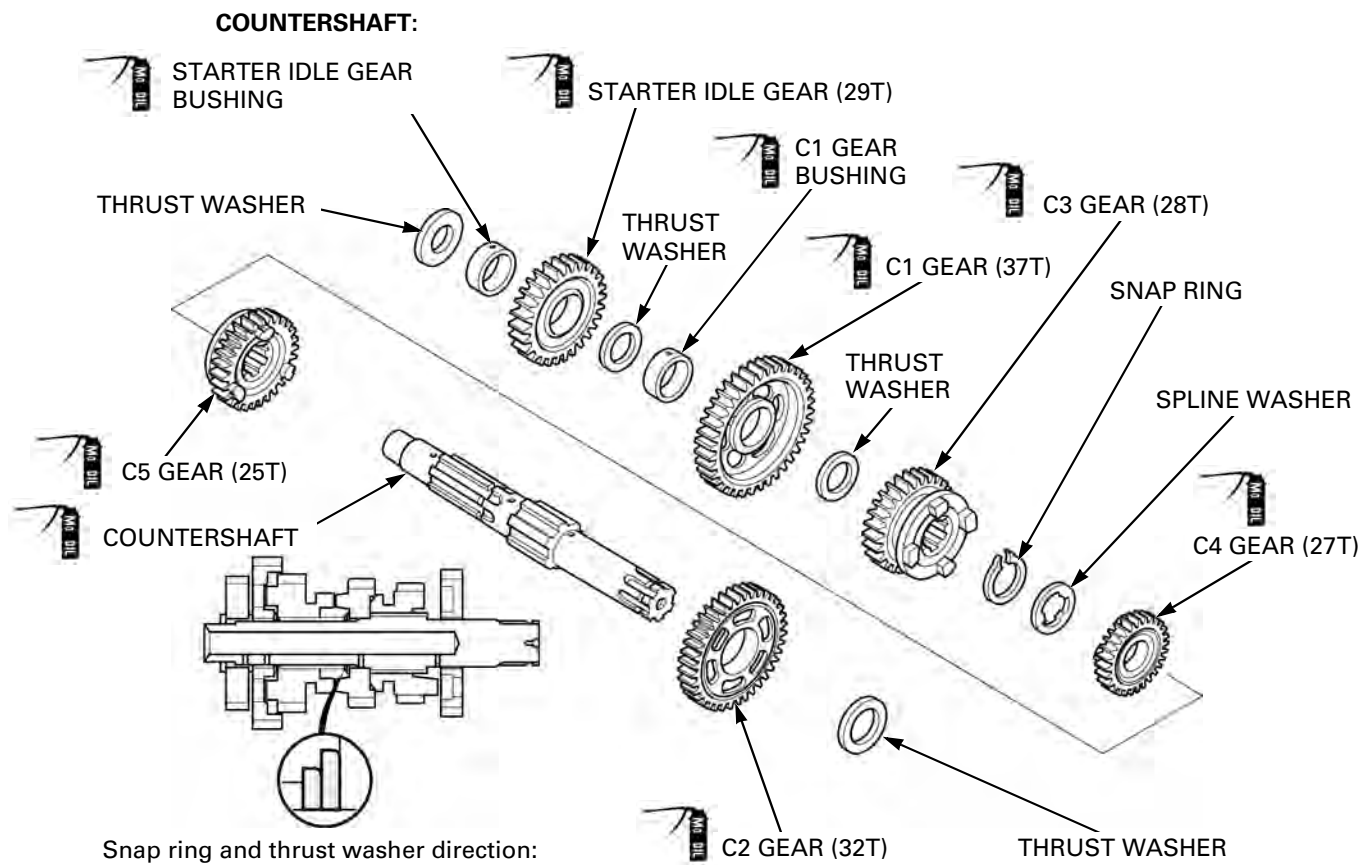

TRANSMISSION INSTALLATION

Coat each gear tooth with molybdenum oil.
Apply molybdenum oil to each shaft, gear and bushing sliding surfaces.
Assemble the transmission gears and shafts.

Always install the washer and snap ring with the chamfered (rolled) edge facing away from the thrust load.

Check the gears for smoothness or rotation on the shafts.

Check that the snap rings are seated in the grooves.

Install the mainshaft and countershaft as an assembly into the right crankcase.

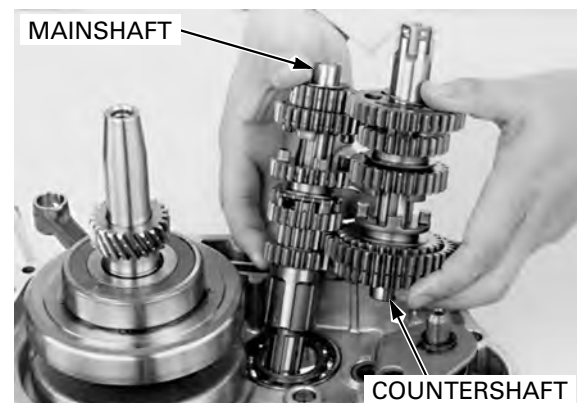
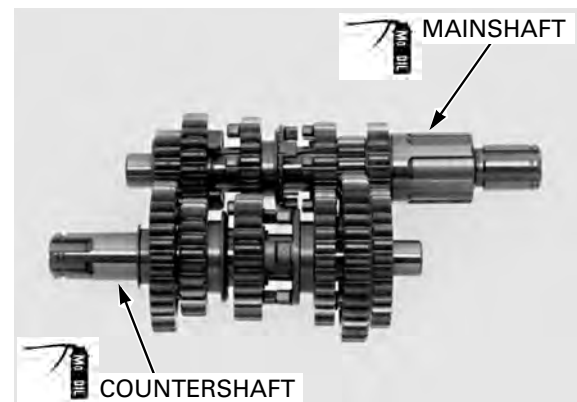

CRANKSHAFT/TRANSMISSION/KICKSTARTER

Each shift fork has an identification mark; "R" is for the right shift fork, "C" is for the center shift fork, and "L" is for the left shift fork.

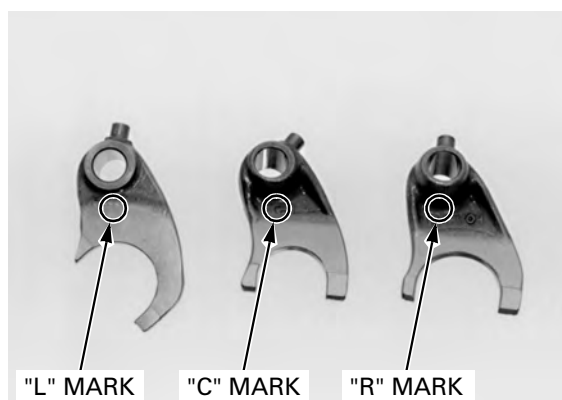

Apply engine oil to the shift forks sliding surfaces. Install the right shift fork into the C5 shifter groove with its mark facing the right crankcase. Install the center shift fork into the M4 shifter groove with its mark facing the left crankcase. Install the left shift fork into the C3 shifter groove with its mark facing the right crankcase. Install the shift drum.

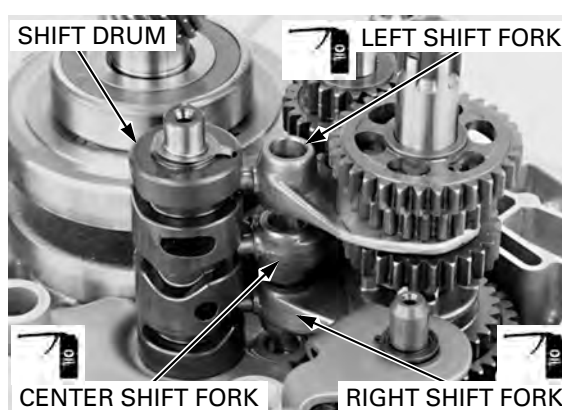

Apply engine oil to the shift fork shaft and install it. After installation, check for smooth transmission operation.

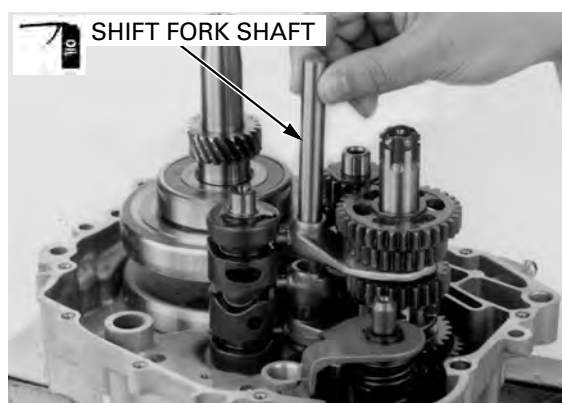

KICKSTARTER

REMOVAL

Unhook the ratchet guide plate and starter ratchet and remove the kickstarter assembly.

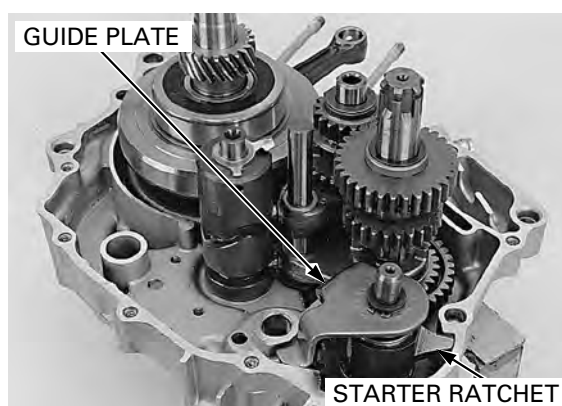

CRANKSHAFT/TRANSMISSION/KICKSTARTER

DISASSEMBLY

Remove the following:

- Thrust washer, 16 mm
- Spindle collar
- Kickstarter spring
- Spring retainer

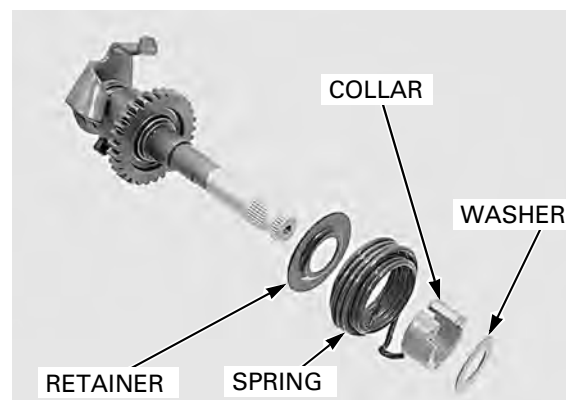

Remove the following:

- Thrust washer, 12 mm
- Snap ring, 16 mm
- Ratchet guide plate
- Ratchet spring
- Thrust washer, 16 mm

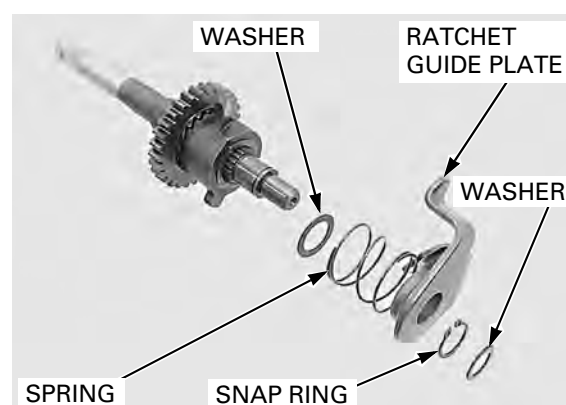

Remove the starter ratchet.

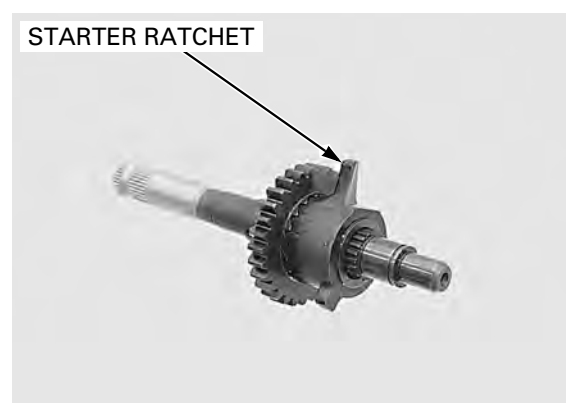

Remove the following:

- Snap ring, 20 mm
- Thrust washer, 20 mm
- Kickstarter pinion gear

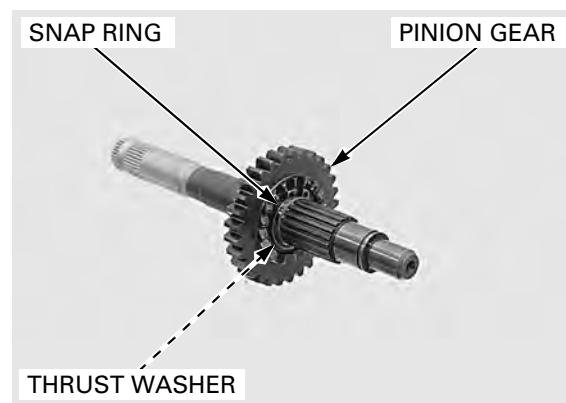

CRANKSHAFT/TRANSMISSION/KICKSTARTER

INSPECTION

Measure the kickstarter pinion I.D.

SERVICE LIMIT: 20.05 mm (0.789 in)

Measure the O.D. of the kickstarter pinion gear sliding surface on the spindle.

SERVICE LIMIT: 19.90 mm (0.783 in)

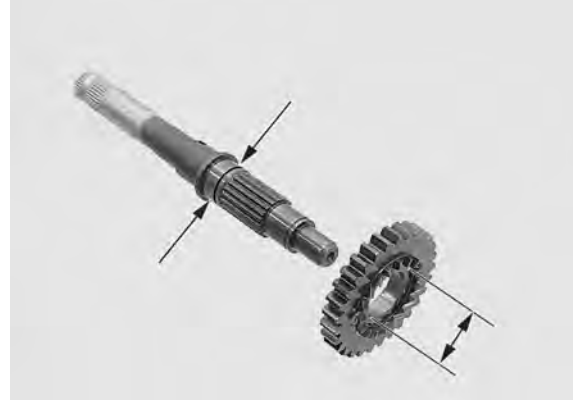

ASSEMBLY

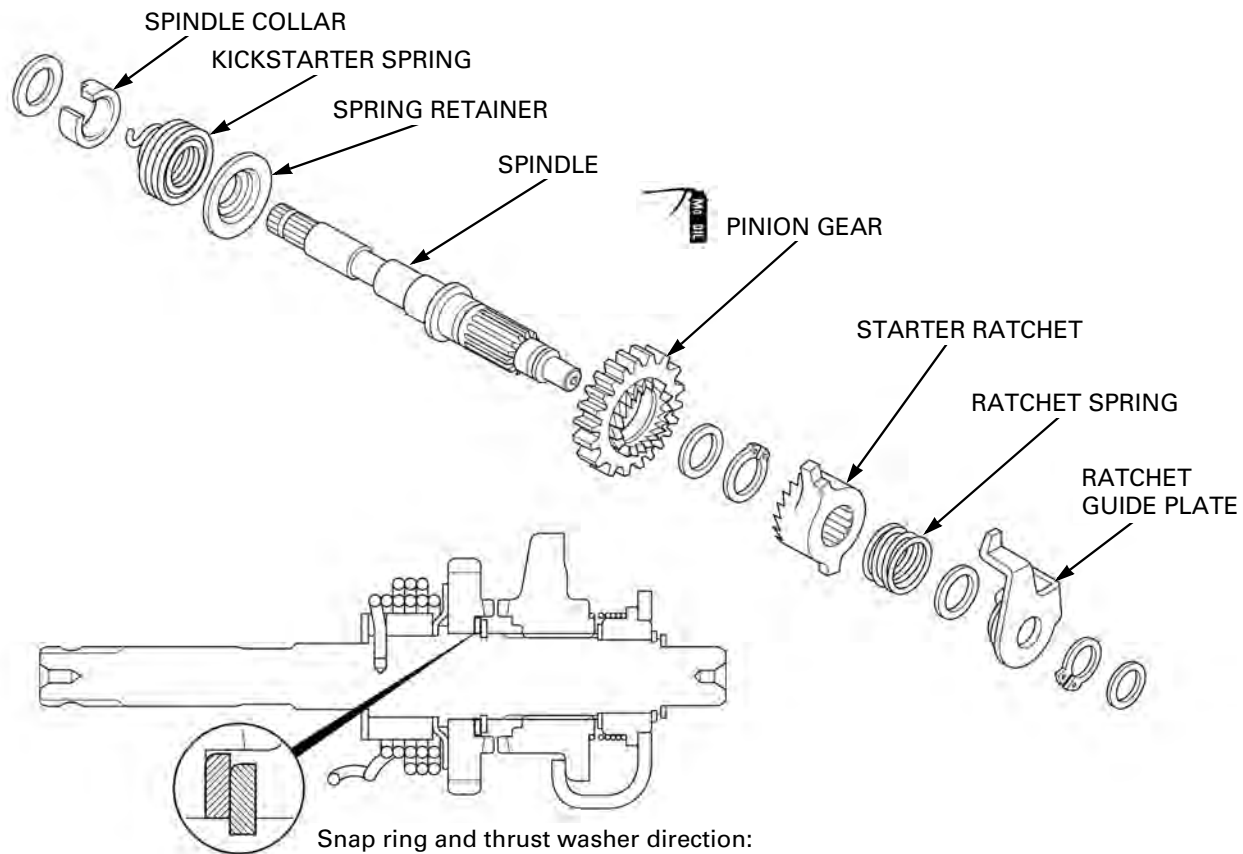

Apply molybdenum oil to the kickstarter pinion gear teeth and inner surface.

Install the following:

- Kickstarter pinion gear
- Thrust washer, 20 mm
- Snap ring, 20 mm

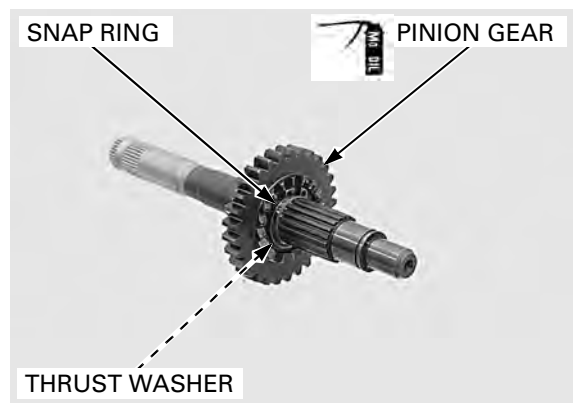

CRANKSHAFT/TRANSMISSION/KICKSTARTER

Install the starter ratchet by aligning the punch marks on the starter ratchet and spindle.

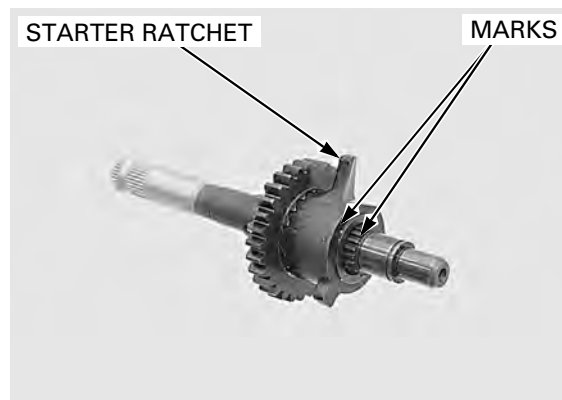

Install the following:

- Thrust washer, 16 mm
- Ratchet spring
- Ratchet guide plate
- Snap ring, 16 mm
- Thrust washer, 12 mm

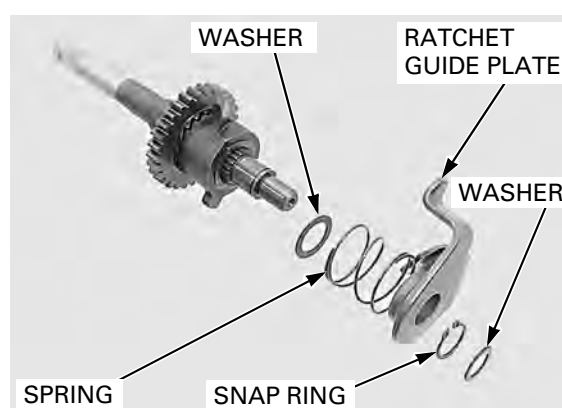

Install the following:

- Spring retainer
- Kickstarter spring
- Spindle collar

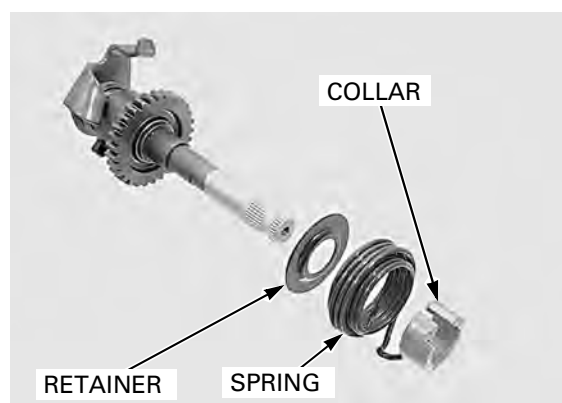

Install the kickstarter spring end into the spindle.

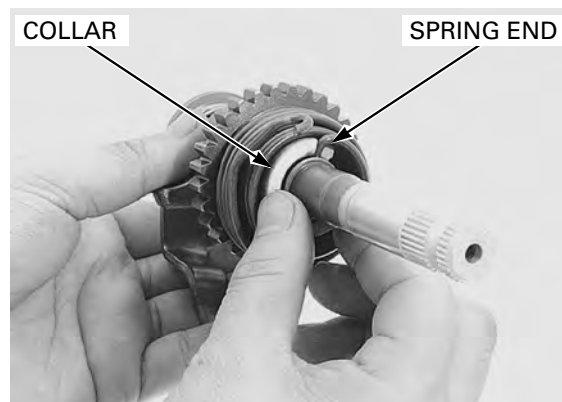

CRANKSHAFT/TRANSMISSION/KICKSTARTER

Align the cut-out of the spindle collar with the spring end.

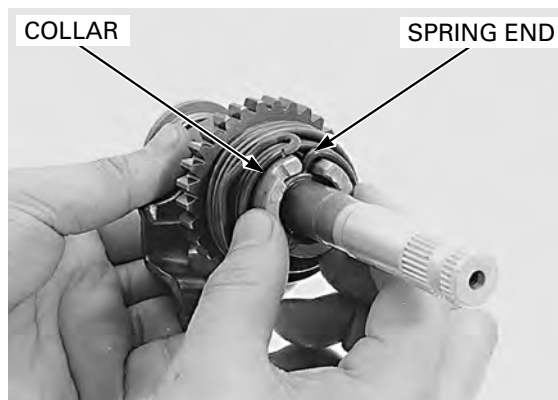

Install the thrust washer.



INSTALLATION

Apply engine oil to the kickstarter assembly.

Install the kickstarter assembly into the left crankcase.

Hook the kickstarter spring end to the left crankcase hole.

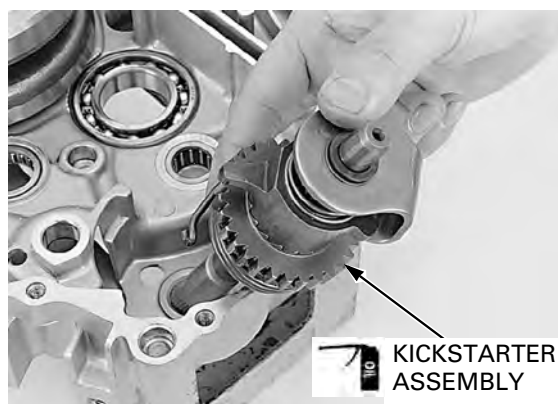

Hold the kickstarter spindle and hook the starter ratchet and ratchet guide plate to the left crankcase.

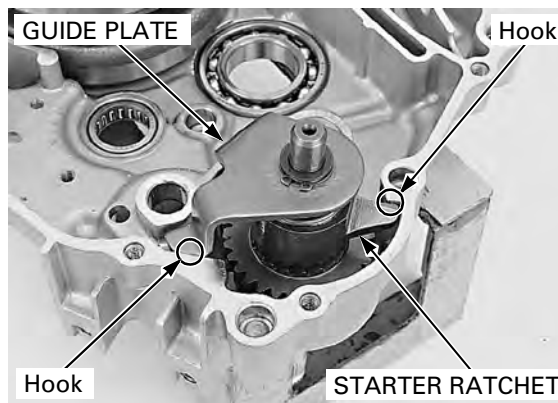

CRANKCASE ASSEMBLY

Apply oil to the crankshaft bearing.
Install the crankshaft into the right crankcase.

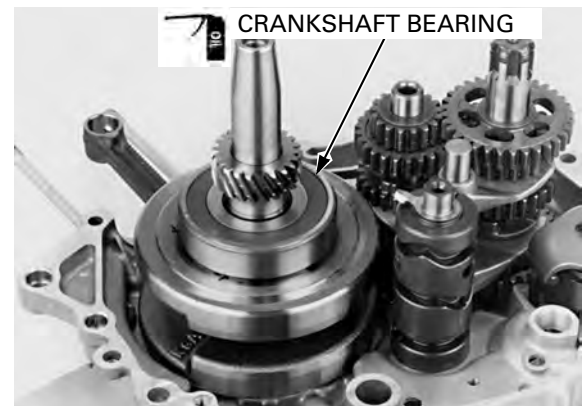

Install the dowel pins and new gasket.

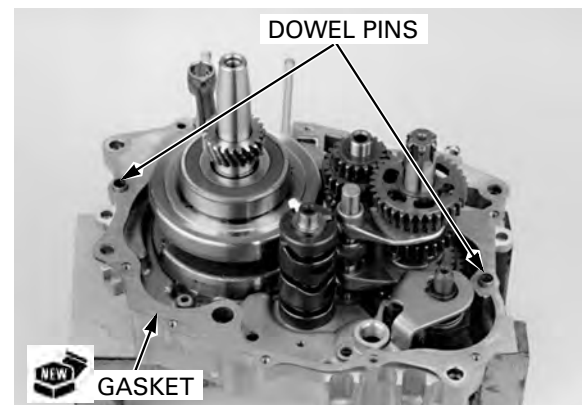

Make sure that the gasket stays in place during this operation. Install the left crankcase on the right crankcase.

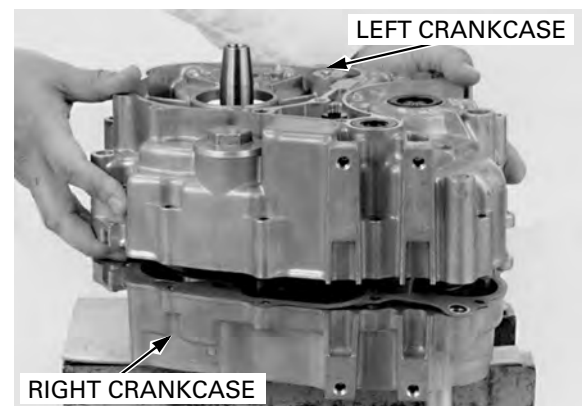

Install the left crankcase bolts and tighten them securely in a crisscross pattern in 2-3 steps.

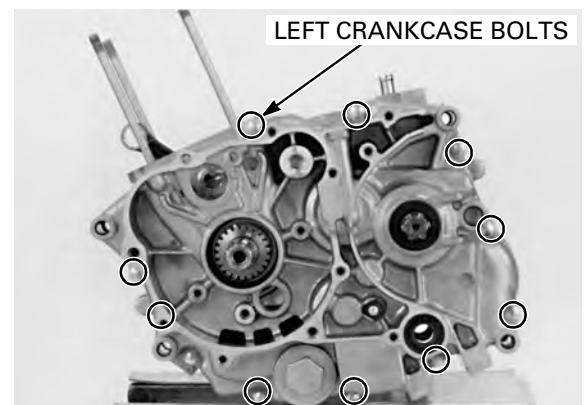

CRANKSHAFT/TRANSMISSION/KICKSTARTER

Install the clutch cable stay and tighten the clutch cable stay bolt.

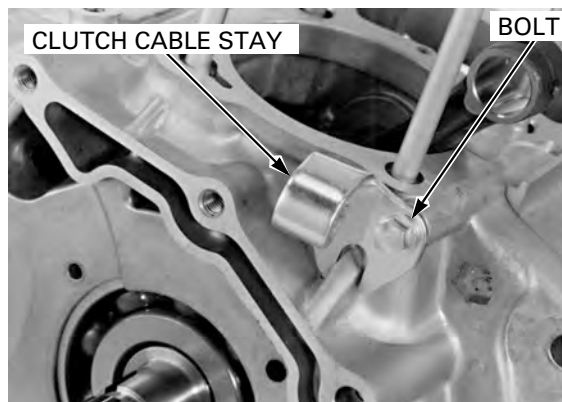

Check the push plug, spring, and push plug holder for wear or damage and replace them with new ones if necessary.

Apply clean engine oil to the spring.
Apply clean engine oil to the push plug surface and spring end.

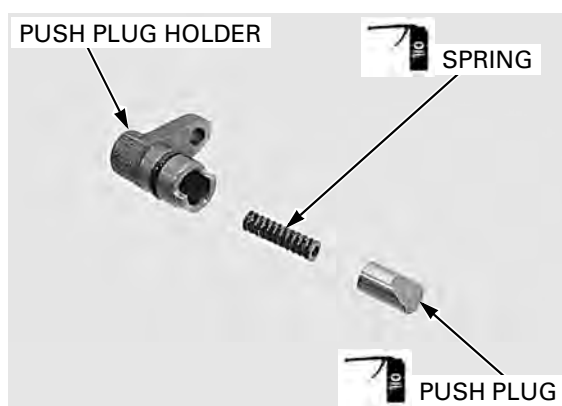

Apply clean engine oil to the new O-ring and install it to the push plug holder.
Install the push plug holder assembly to the left crankcase.
Install and tighten the push plug holder bolt to the specified torque.

TORQUE: 13 N·m (1.3 kgf·m, 10 lbf·ft)

Install the following:

- Woodruff key (page 10-9)
- Primary drive gear (page 9-9)
- Flywheel (page 10-9)
- Gearshift linkage (page 9-12)
- Clutch (page 9-9)
- Oil pump (page 4-9)
- Piston (page 8-12)
- Cylinder (page 8-5)
- Cylinder head (page 7-20)
- Starter motor (page 17-13)
- Footpeg bar (page 2-8)
- Engine (page 6-10)

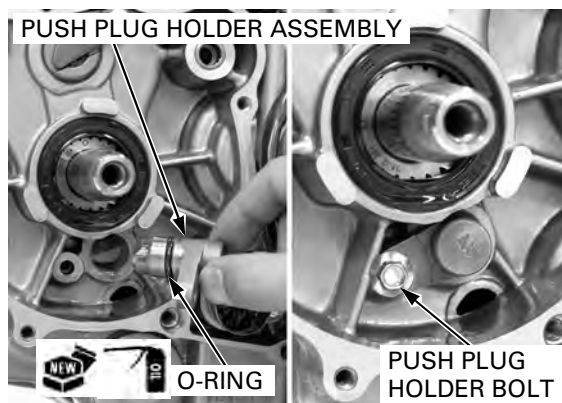

12. FRONT WHEEL/BRAKE/SUSPENSION/STEERING

SYSTEM COMPONENTS	12-2	FRONT WHEEL (TYPE: II, IV)	12-15
SERVICE INFORMATION	12-4	FRONT DRUM BRAKE (TYPE: I, III)	12-20
TROUBLESHOOTING	12-6	FORK	12-24
HANDLEBAR	12-7	STEERING STEM	12-31
FRONT WHEEL (TYPE: I, III)	12-11		

FRONT WHEEL/BRAKE/SUSPENSION/STEERING

SYSTEM COMPONENTS

TYPE I, III

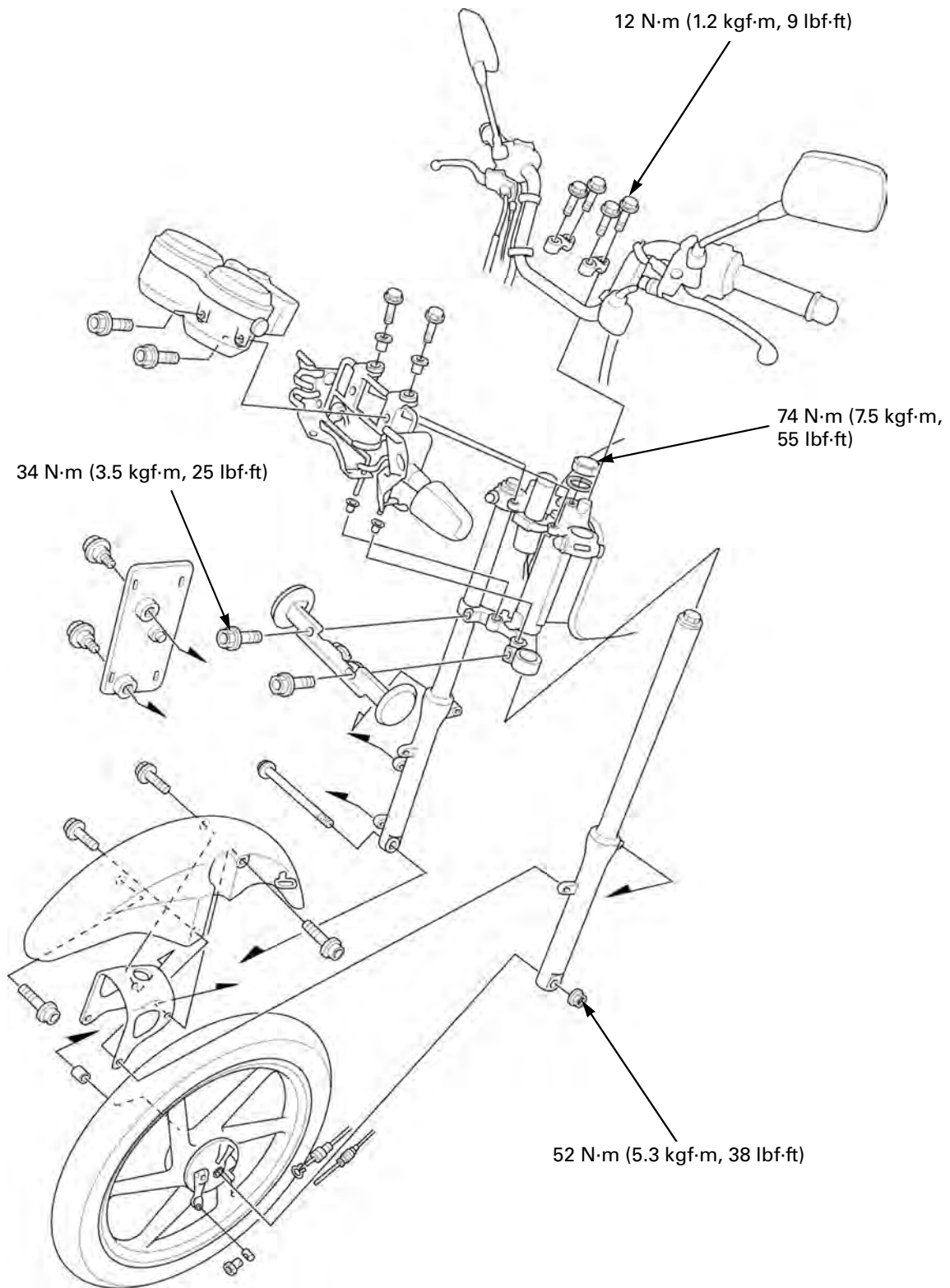

FRONT WHEEL/BRAKE/SUSPENSION/STEERING

TYPE II, IV

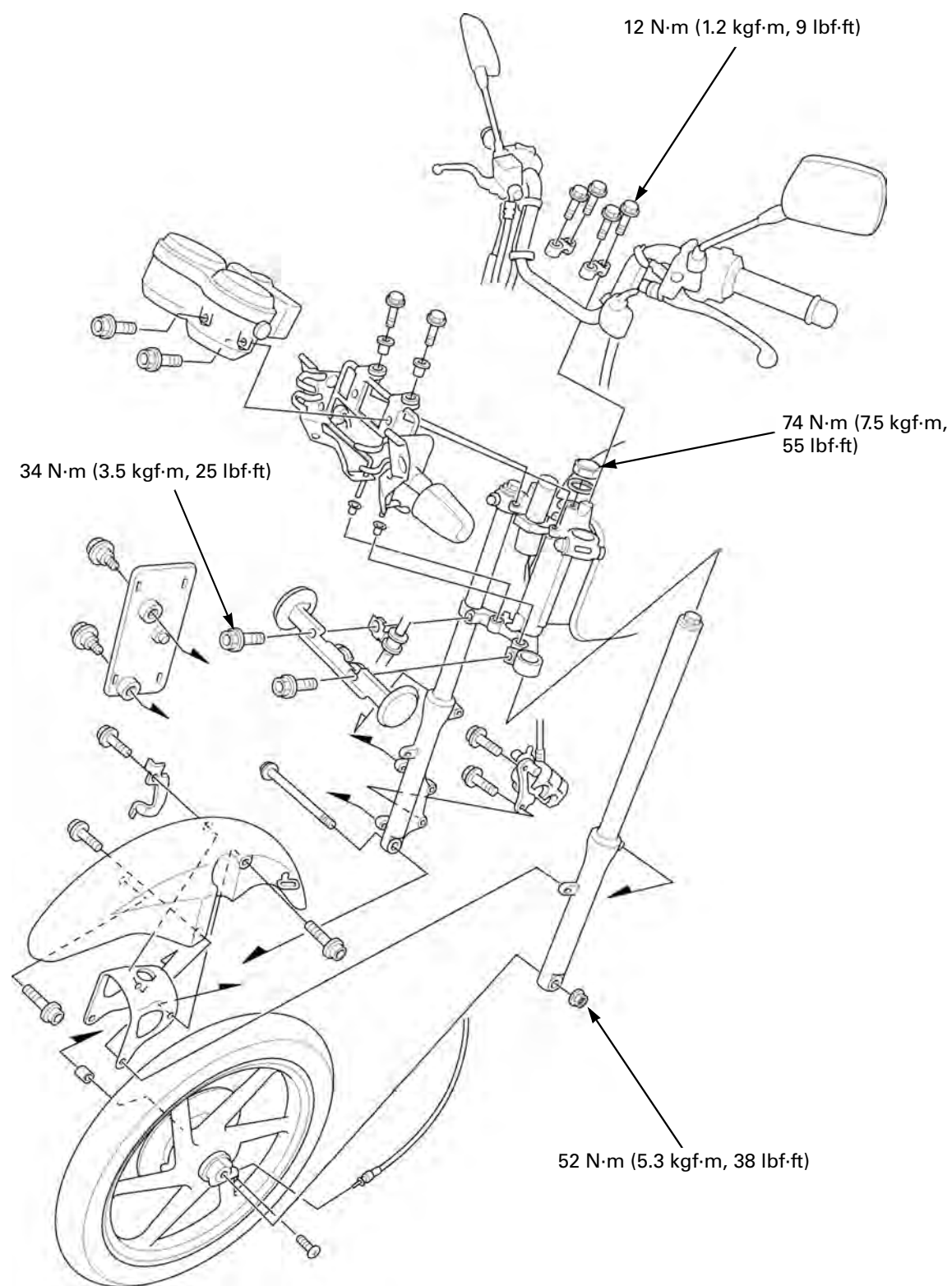

FRONT WHEEL/BRAKE/SUSPENSION/STEERING

SERVICE INFORMATION

GENERAL

⚠ CAUTION

Frequent inhalation of brake shoe dust, regardless of material composition could be hazardous to your health.

- Avoid breathing dust particles.
- Never use an air hose or brush to clean brake assemblies. Use an OSHA-approved vacuum cleaner.

- When servicing the front wheel, fork or steering stem, support the motorcycle using a safety stand or hoist.
- A contaminated brake disc or pad reduces stopping power. Discard contaminated pads and clean a contaminated disc with a high quality brake degreasing agent.
- After the front wheel installation, check the brake operation by applying the brake lever.
- Refer to hydraulic brake system information (page 14-3).

SPECIFICATIONS

Unit: mm (in)





ITEM		STANDARD	SERVICE LIMIT
Minimum tire thread depth		–	To wear indicator
Cold tire pressure	Driver only	200 kPa (2.00 kgf/cm ² , 29 psi)	–
	Driver and passenger	200 kPa (2.00 kgf/cm ² , 29 psi)	–
Axle runout		–	0.2 (0.01)
Wheel rim runout	Radial	–	1.0 (0.04)
	Axial	–	1.0 (0.04)
Drum brake (Type I, III)	Lever free play	10 – 20 (0.4 – 0.8)	–
	Drum I.D.	130.0 – 130.3 (5.12 – 5.13)	131.0 (5.16)
Fork	Spring free length	485.5 (19.11)	457.2 (18.0)
	Pipe runout	–	0.20 (0.008)
	Recommended fluid	Fork fluid	–
	Fluid level	159 (6.26)	–
	Fluid capacity	65.0 cm ³ (2.20 US oz, 2.29 Imp oz)	–
Steering head bearing pre-load		1.6 – 2.4 kgf (3.53 – 5.29 lbf)	–

TORQUE VALUES

Handlebar holder bolt	12 N·m (1.2 kgf·m, 9 lbf·ft)	
Front brake disc bolt (Type II, IV)	42 N·m (4.3 kgf·m, 31 lbf·ft)	ALOC bolt; replace with a new one.
Front axle nut	52 N·m (5.3 kgf·m, 38 lbf·ft)	
Front brake arm nut (Type I, III)	10 N·m (1.0 kgf·m, 7 lbf·ft)	U-nut
Fork cap	22 N·m (2.2 kgf·m, 16 lbf·ft)	
Top bridge pinch bolt	23 N·m (2.3 kgf·m, 17 lbf·ft)	
Bottom bridge pinch bolt	34 N·m (3.5 kgf·m, 25 lbf·ft)	
Steering bearing adjustment nut	See page 12-35	
Steering stem nut	74 N·m (7.5 kgf·m, 55 lbf·ft)	

FRONT WHEEL/BRAKE/SUSPENSION/STEERING

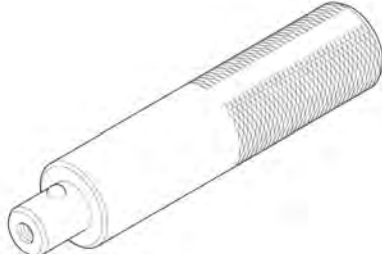
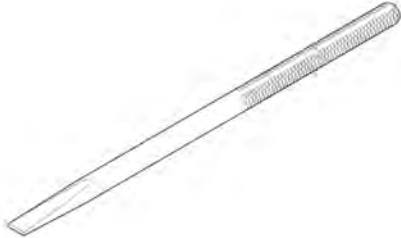
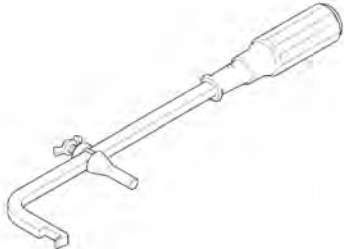
TOOLS

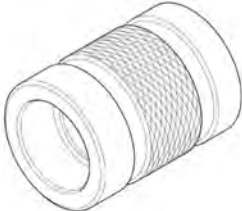
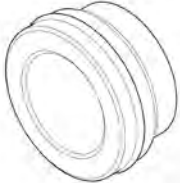
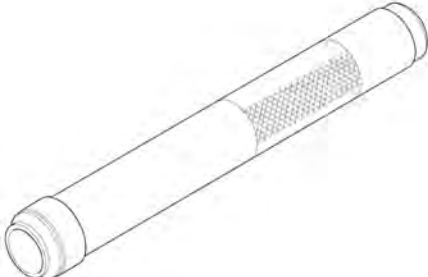
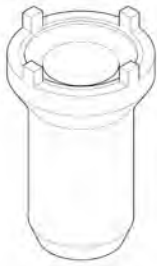
<p>Attachment, 37 x 40 mm 07746-0010200</p> 	<p>Remover head, 12 mm 07746-0050300</p> 	<p>Pilot, 12 mm 07746-0040200</p> 
<p>Driver 07749-0010000</p> 	<p>Bearing remover shaft 07746-0050100</p> 	<p>Oil seal remover 07748-0010001</p> 
<p>Ball race remover 07944-1150001</p> 	<p>Fork seal driver 07747-0010100</p> 	<p>Fork seal driver attachment 07747-0010400</p> 
<p>Steering stem driver 07946-GC40000</p> 	<p>Stem socket wrench 07916-3710101</p> 	

FRONT WHEEL/BRAKE/SUSPENSION/STEERING

TROUBLESHOOTING

Hard steering

- Steering stem adjusting nut too tight
- Damaged steering head bearing/race
- Insufficient tire pressure
- Faulty tire

Steers to one side or does not track straight

- Bent fork
- Bent front axle
- Wheel installed incorrectly
- Faulty steering head bearing
- Bent frame
- Faulty wheel bearing
- Worn swingarm pivot components
- Weak front fork

Front wheel wobbling

- Bent rim
- Worm wheel bearings
- Faulty tire

Wheel hard to turn

- Faulty wheel bearing
- Faulty speedometer gear
- Bent front axle
- Brake drag

Soft suspension

- Weak front fork spring
- Insufficient fork fluid
- Tire pressure too low

Hard suspension

- Incorrect fork fluid viscosity
- Bent fork pipes
- Clogged fluid passage
- Damaged fork pipe and/or fork slider

Front suspension noisy

- Insufficient fluid in fork
- Loose front fork fasteners
- Lack of grease in speedometer gear

HANDLEBAR

REMOVAL

Remove the wire bands and rear view mirrors.

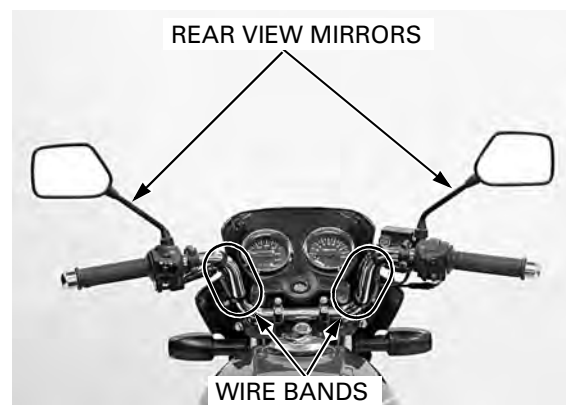

When removing the weight, do not remove the screw from the nut.

Hold the handlebar weight and loosen the screw. Remove the handlebar weight, rubber and nut assembly.

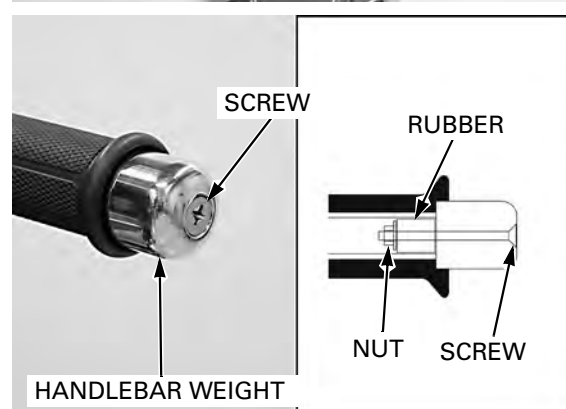

Disconnect the front brake light switch connectors. Remove the bolts and brake lever bracket holder.

Type II and IV: Remove the master cylinder.
Type I and III: Remove the brake lever bracket.

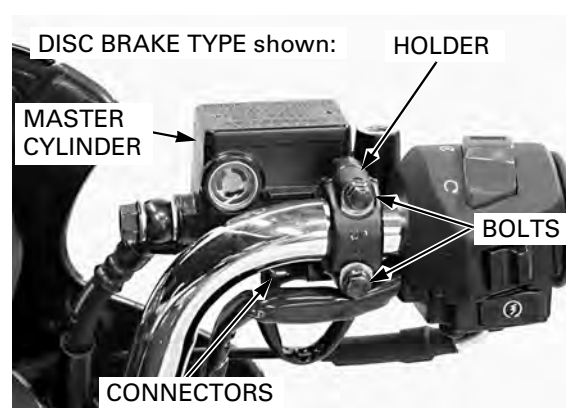

Remove the right handlebar switch housing screws.



FRONT WHEEL/BRAKE/SUSPENSION/STEERING

Separate the right handlebar switch housing.
Disconnect the throttle cable from the throttle pipe,
then remove the throttle pipe.

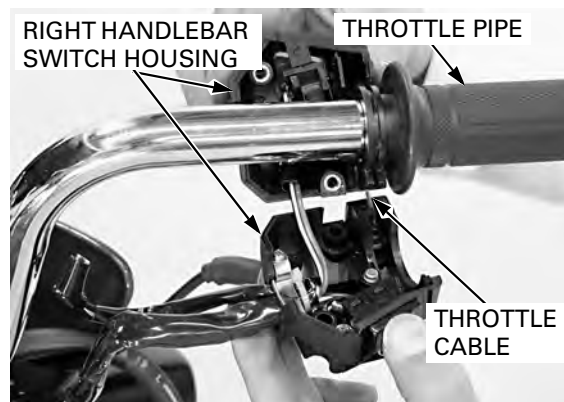

Disconnect the clutch switch connectors.
Remove the bolts, clutch lever bracket and holder.

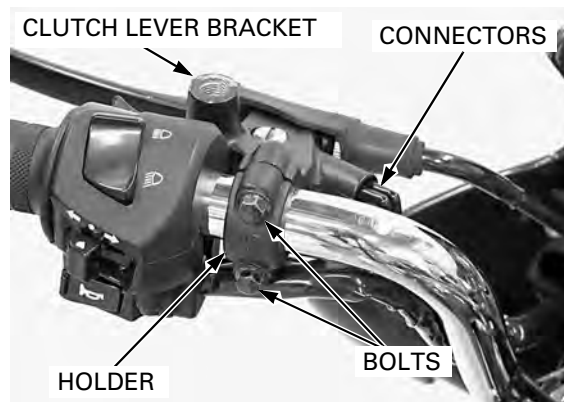

Remove the screws and left handlebar switch housing.
Remove the handlebar grip.

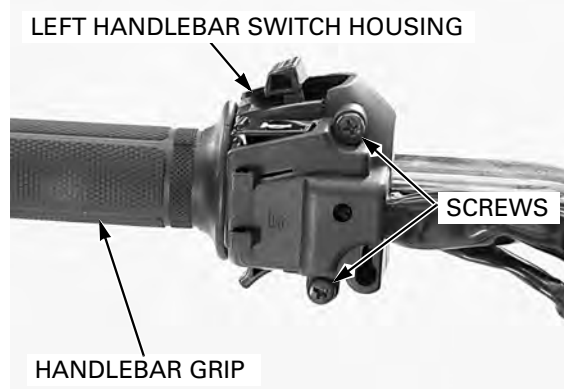

Remove the bolts, handlebar holders and handlebar
from the top bridge.

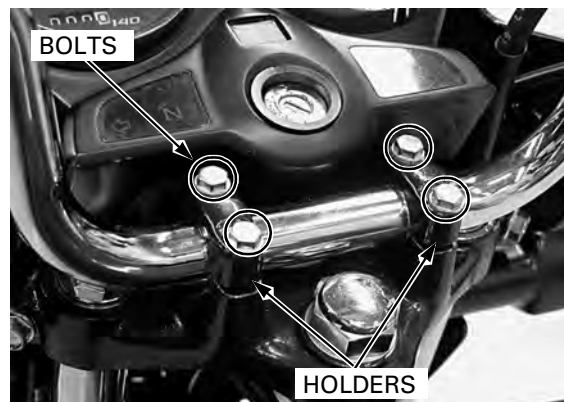

FRONT WHEEL/BRAKE/SUSPENSION/STEERING

INSTALLATION

Place the handlebar to the top bridge.
Place the handlebar holders and install the holder bolts.

Align the punch mark on the handlebar with the top surface of the lower holder.
Tighten the front bolts first, then the rear bolts.

TORQUE: 12 N·m (1.2 kgf·m, 9 lbf·ft)

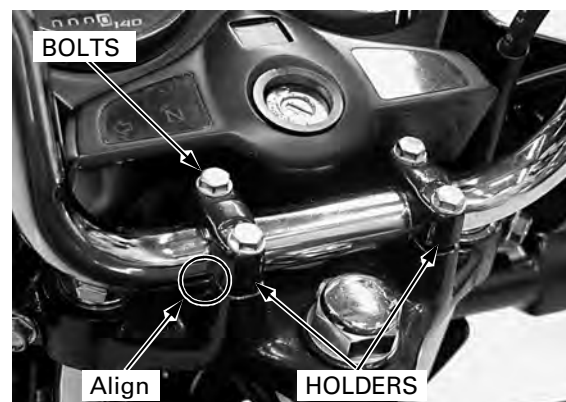

Apply Honda Bond A or its equivalent to the inside surface of the grips and to the clean surface of the left handlebar.

Allow the adhesive to dry for 1 hour before using.

Wait 3 – 5 minutes and install the grip.
Rotate the grips for even application of the adhesive.

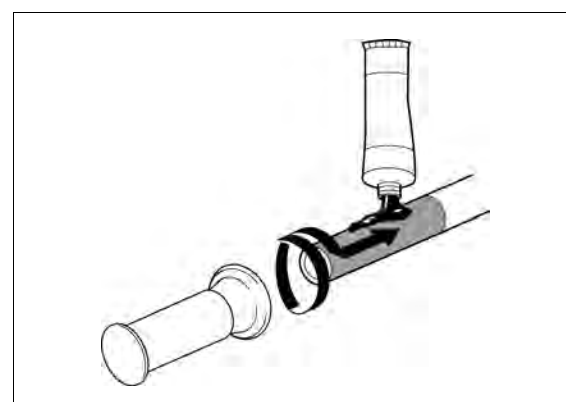

Install the left handlebar switch housing, aligning the locating pin in the housing with the hole in the handlebar.

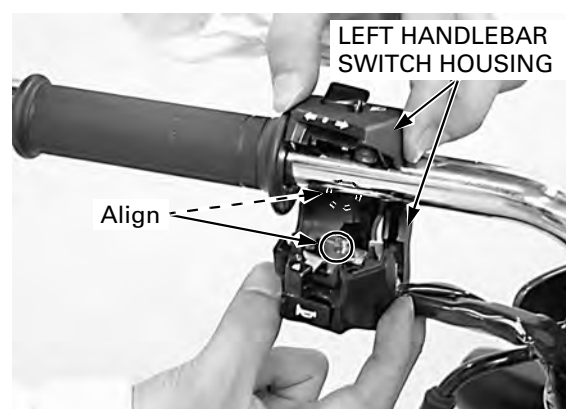

Install the screws and tighten the front screw first, then the rear screw.

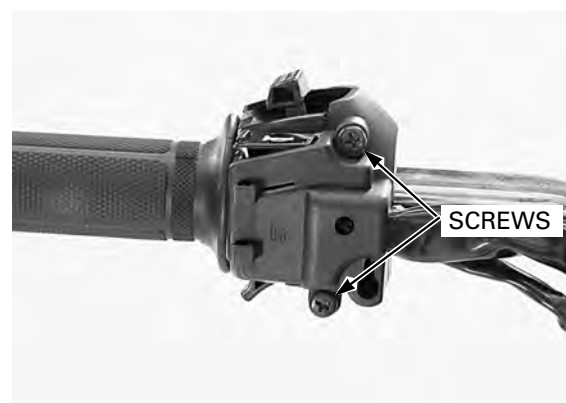

FRONT WHEEL/BRAKE/SUSPENSION/STEERING

Install the clutch lever bracket onto the left side of handlebar aligning the end of bracket with the punch mark on the handlebar.

Install the holder with the "UP" mark facing up. Install the bolts and tighten the upper bolt first, then tighten the lower bolt.

Connect the clutch switch connectors.

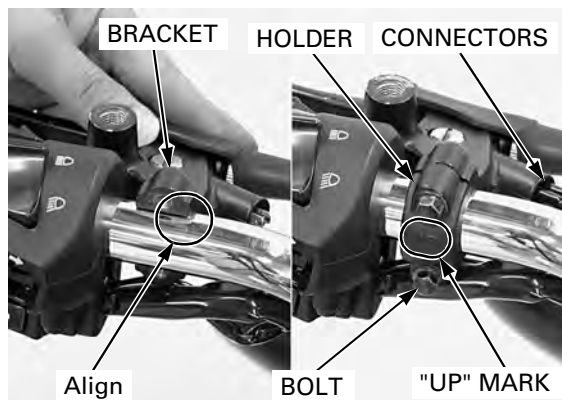

Install the throttle pipe on the handlebar. Apply grease to the throttle cable contacting area of the throttle pipe and throttle cable end. Connect the throttle cable end to the throttle pipe.

Install the right handlebar switch housing, aligning its locating pin with the hole on the handlebar.

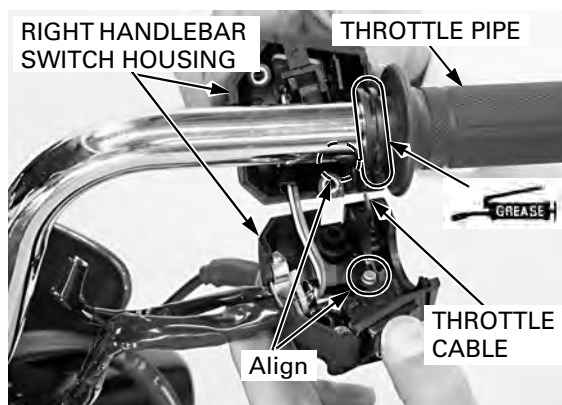

Install the screws and tighten the front screw first, then the rear screw.

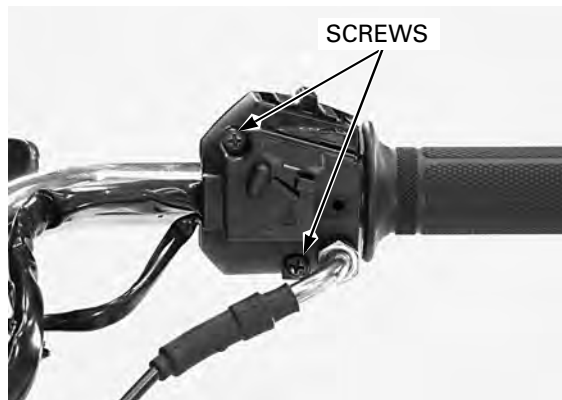

Type II and IV: Install the master cylinder aligning the end of bracket with the punch mark on the handlebar.

Type I and III: Install the brake lever bracket aligning the end of bracket with the punch mark on the handlebar.

Install the holder with the "UP" mark facing up. Install the bolts and tighten the upper bolt first, then tighten the lower bolt.

Connect the brake light switch connectors.

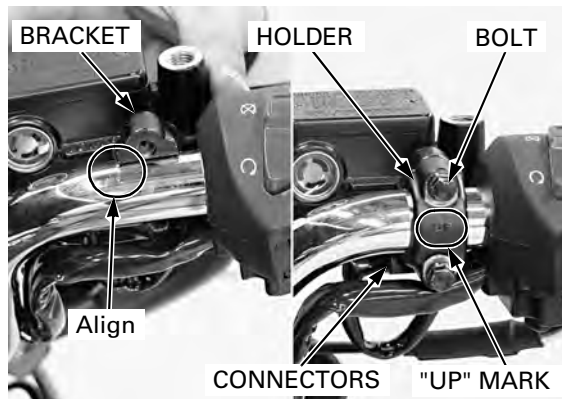

FRONT WHEEL/BRAKE/SUSPENSION/STEERING

Temporarily assemble the handlebar weight, rubber and nut.

Install the handlebar weight assembly to the handlebar.

Hold the handlebar weight and tighten the screw until the handlebar weight is tight.

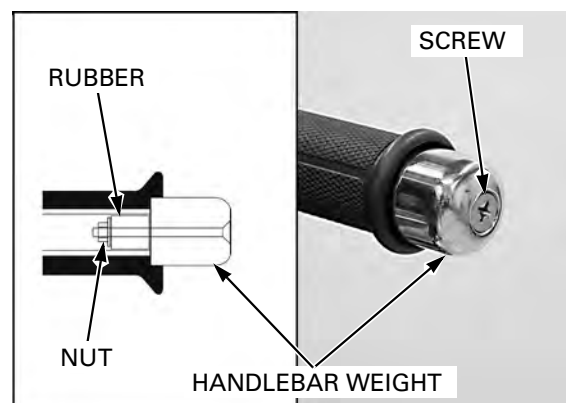

Route the wire harness properly (type I and III: page 1-18, type II and IV: page 1-19).

Install the wire bands and rear view mirrors.

Check the throttle grip free play (page 3-5).

Adjust the clutch lever free play (page 3-18).

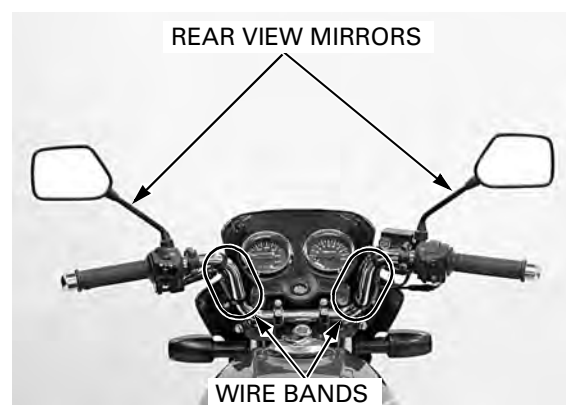

FRONT WHEEL (TYPE: I, III)

REMOVAL

Raise and support the motorcycle using safety stand or a box.

Remove the retaining clip and disconnect the speedometer cable.

Remove the front brake adjusting nut, brake cable and brake arm joint pin.

Remove the axle nut.

Remove the axle and front wheel.

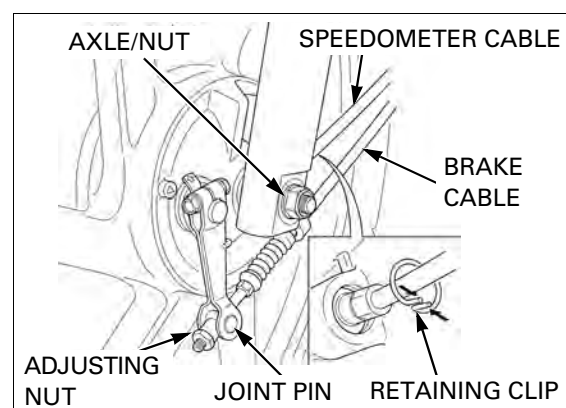

Remove the side collar and dust seal.

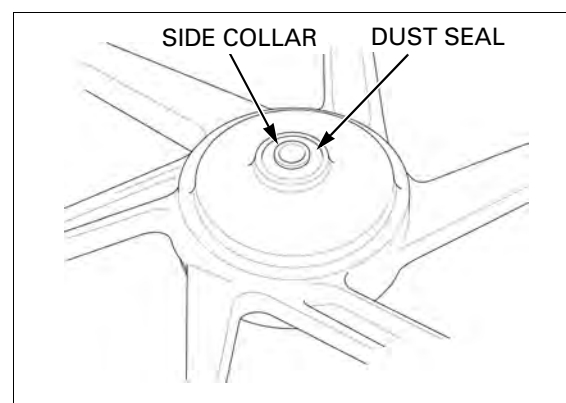

FRONT WHEEL/BRAKE/SUSPENSION/STEERING

Remove the brake panel assembly from left wheel hub.

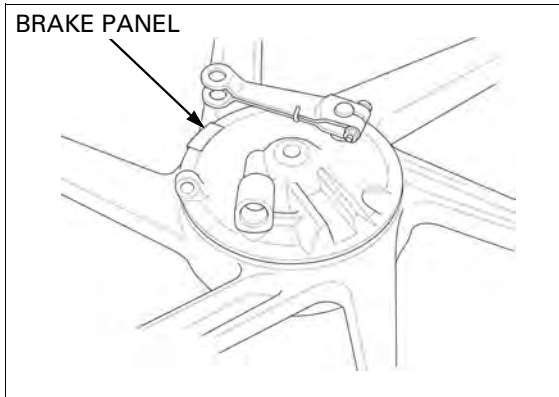

INSPECTION

Place the axle in V-blocks and measure the runout with a dial indicator.

Actual runout is 1/2 of the total indicator reading.

SERVICE LIMIT: 0.2 mm (0.01 in)

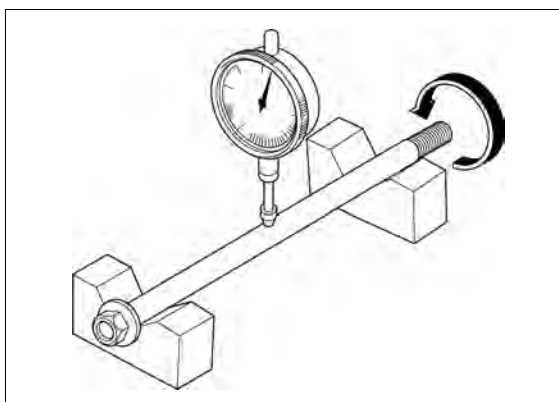

Check the wheel rim runout by placing the wheel in a turning stand. Spin the wheel by hand and read the runout using a dial indicator.

SERVICE LIMIT:

Axial: 1.0 mm (0.04 in)

Radial: 1.0 mm (0.04 in)

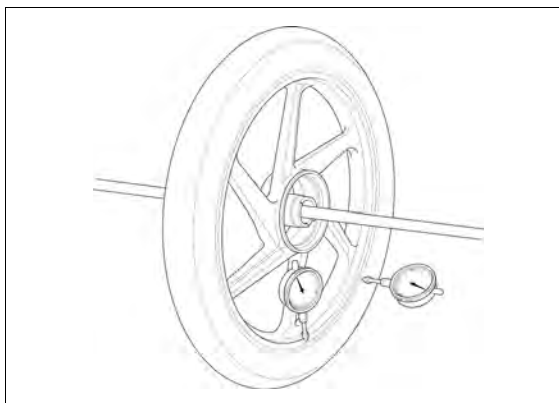

Turn the inner race of each bearing with your finger, the bearing should turn smoothly and quietly. Also check that the bearing outer race fits tightly in the hub.

Replace the bearings in pairs.

Remove and discard the bearings if the races do not turn smoothly, quietly, or if they fit loosely in the hub.

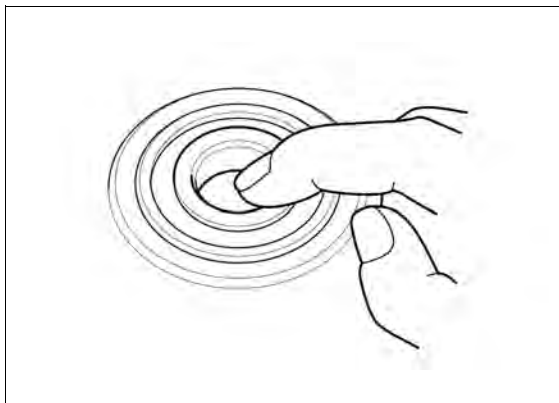

FRONT WHEEL/BRAKE/SUSPENSION/STEERING

DISASSEMBLY

Install the bearing remover head into the bearing. From the opposite side, install the bearing remover shaft and drive the bearing out of the wheel hub. Remove the distance collar and drive out the other bearing.

TOOLS:

Remover head, 12 mm
Bearing remover shaft

07746-0050300
07746-0050100

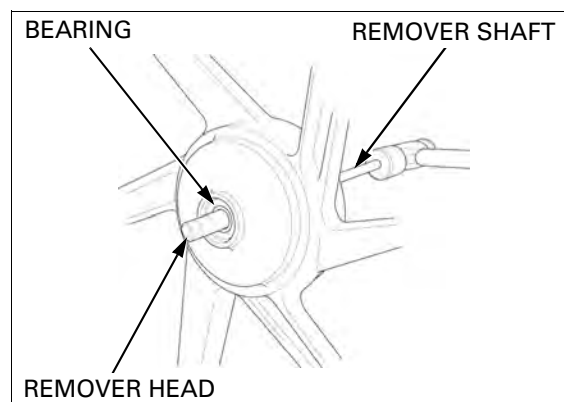

ASSEMBLY

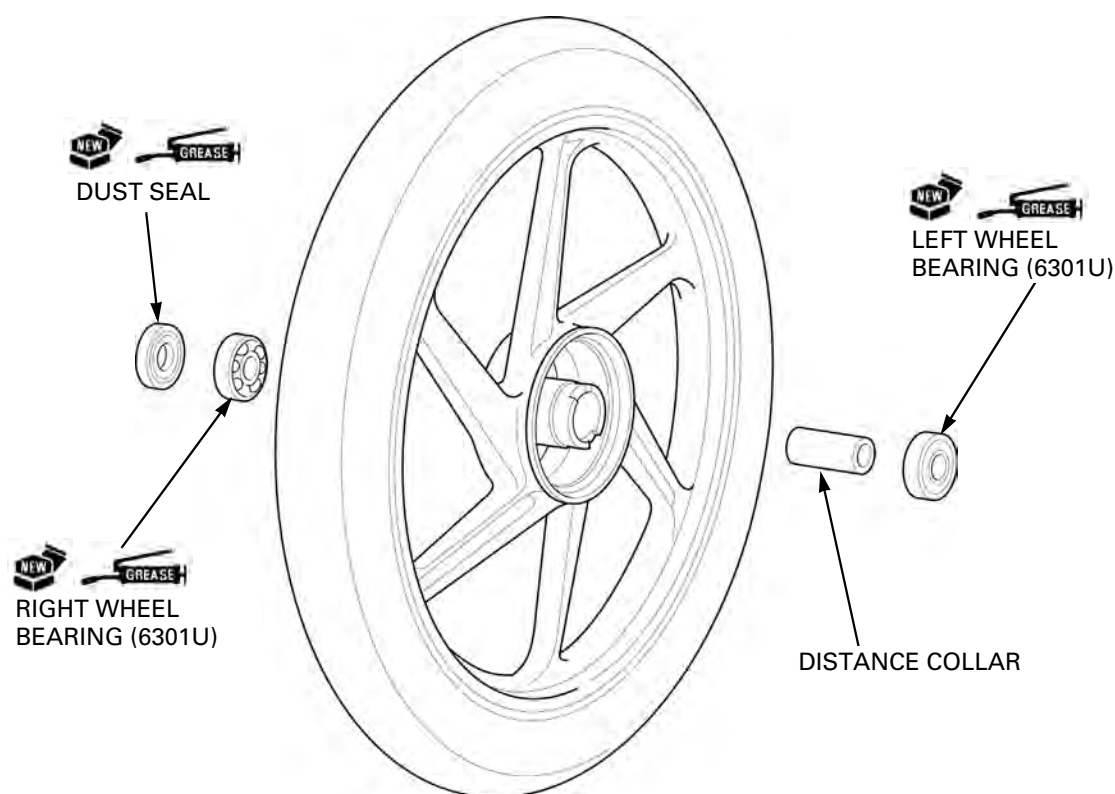

WHEEL ASSEMBLY

Never install the old bearing, once the bearing has been removed, the bearing must be replaced with new ones.

Pack all bearing cavities with grease.
Drive in a new left (brake drum side) bearing squarely with its sealed side facing up until it is fully seated.
Install the distance collar.
Drive in a new right bearing squarely with its sealed side facing up.

TOOLS:

Driver
Attachment, 37 x 40 mm
Pilot, 12 mm

07749-0010000
07746-0010200
07746-0040200

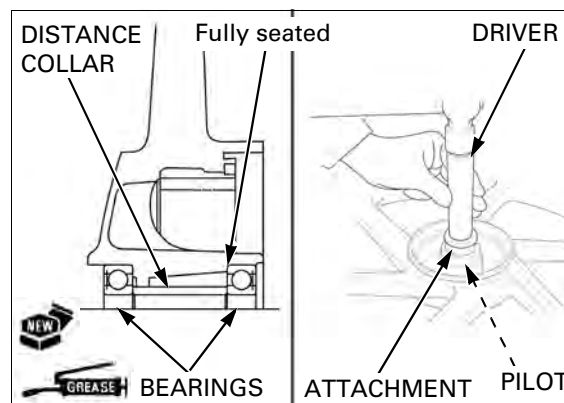

FRONT WHEEL/BRAKE/SUSPENSION/STEERING

INSTALLATION

Apply grease to a new right dust seal lip.
Install the dust seal and side collar to the right wheel hub.

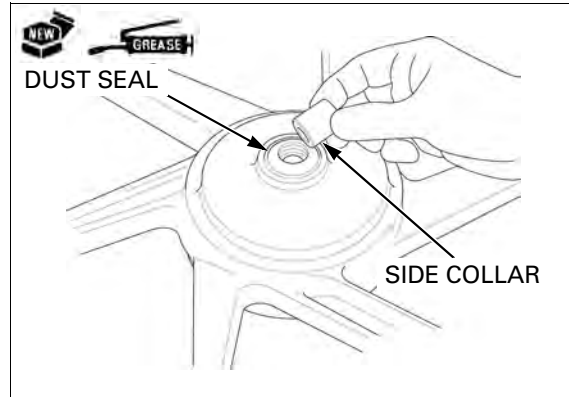

Do not get grease on the brake drum and shoe linings.

Install the brake panel assembly into the left wheel hub, aligning the speedometer tab with the wheel hub slot.

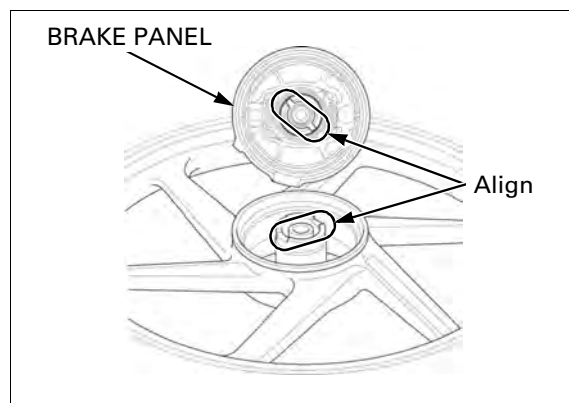

Install the front wheel between the fork legs, aligning the brake panel groove with the boss on the left fork leg.

Install the front axle from right side.

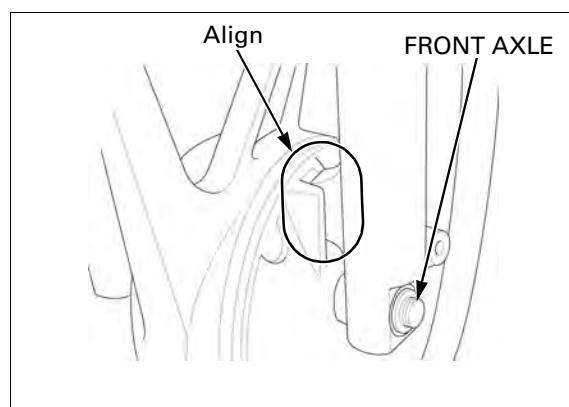

Install and tighten the axle nut to the specified torque.

TORQUE: 52 N·m (5.3 kgf·m, 38 lbf·ft)

Install the speedometer cable and retaining clip.

Install the brake arm joint pin, brake cable and front brake adjusting nut.

Adjust the brake lever free play and check the brake operation (page 3-16).

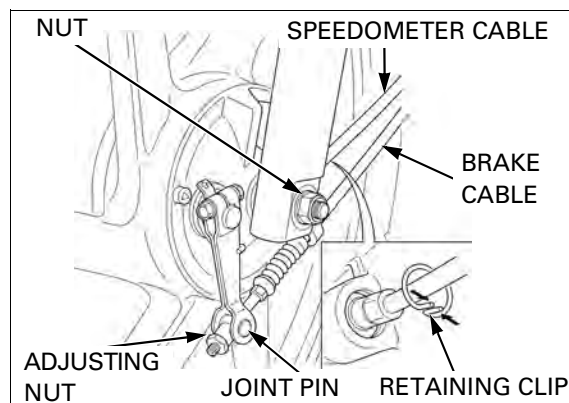

FRONT WHEEL (TYPE: II, IV)

REMOVAL

Raise and support the motorcycle using safety stand or a box.

Remove the screw and speedometer cable.

Remove the axle nut.

Remove the axle and front wheel.

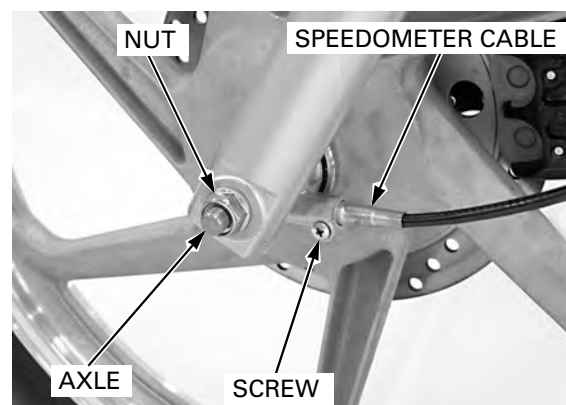

Remove the side collar.

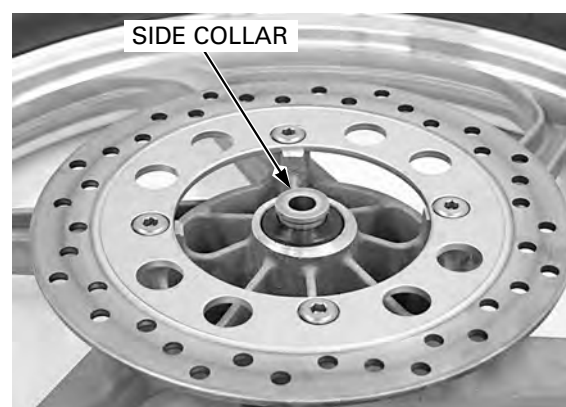

Remove the speedometer gear box.



INSPECTION

AXLE

Place the axle in V-blocks and measure the runout with a dial indicator.

Actual runout is 1/2 of the total indicator reading.

SERVICE LIMIT: 0.2 mm (0.01 in)

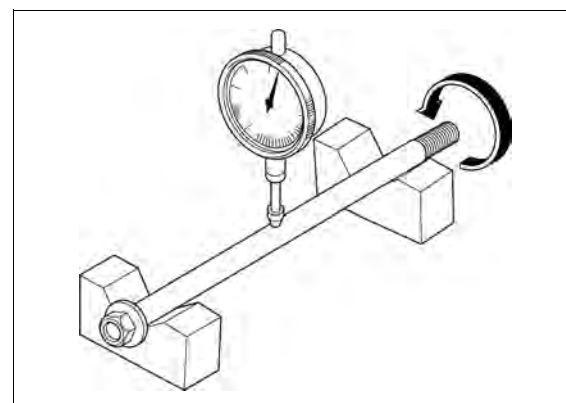

FRONT WHEEL/BRAKE/SUSPENSION/STEERING

WHEEL RIM RUNOUT

Check the wheel rim runout by placing the wheel in a turning stand. Spin the wheel by hand and read the runout using a dial indicator.

SERVICE LIMIT:

Axial: 1.0 mm (0.04 in)

Radial: 1.0 mm (0.04 in)

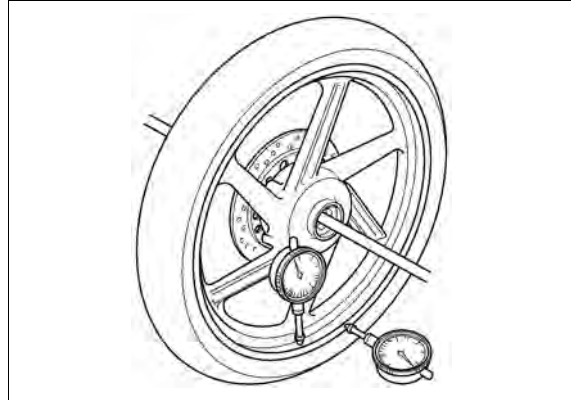

WHEEL BEARING

Turn the inner race of each bearing with your finger, the bearing should turn smoothly and quietly. Also check that the bearing outer race fits tightly in the hub.

Replace the bearings in pairs.

Remove and discard the bearings if the races do not turn smoothly, quietly, or if they fit loosely in the hub.

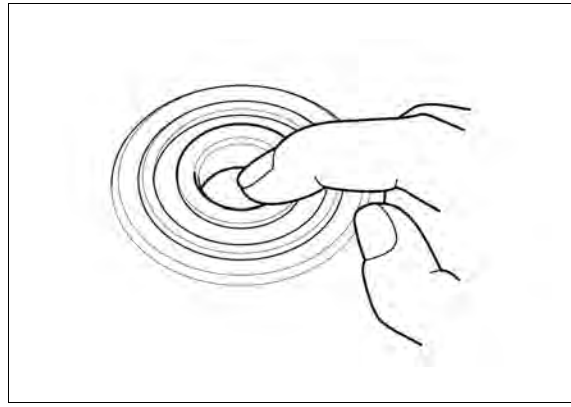

DISASSEMBLY

Remove the left dust seal from the left side of the front wheel.



Remove the speedometer gear retainer.

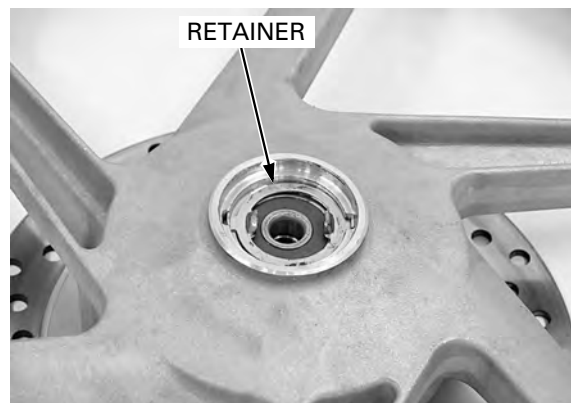

FRONT WHEEL/BRAKE/SUSPENSION/STEERING

Remove the right dust seal from the right side of the front wheel.

Remove the brake disc mounting bolts and brake disc.

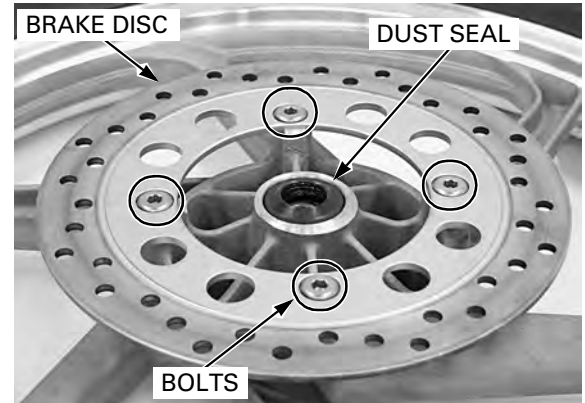

Install the bearing remover head into the bearing. From the opposite side, install the bearing remover shaft and drive the bearing out of the wheel hub. Remove the distance collar and drive out the other bearing.

TOOLS:

Remover head, 12 mm
Bearing remover shaft

07746-0050300
07746-0050100

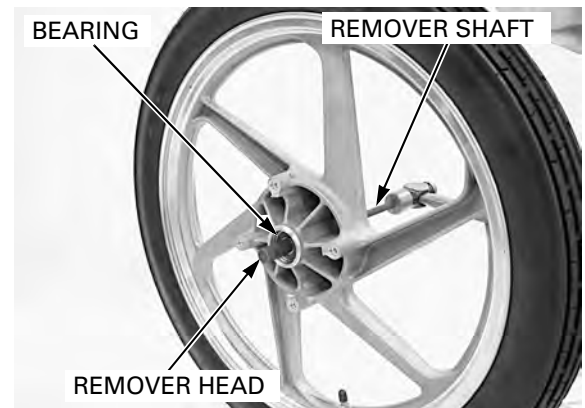

ASSEMBLY

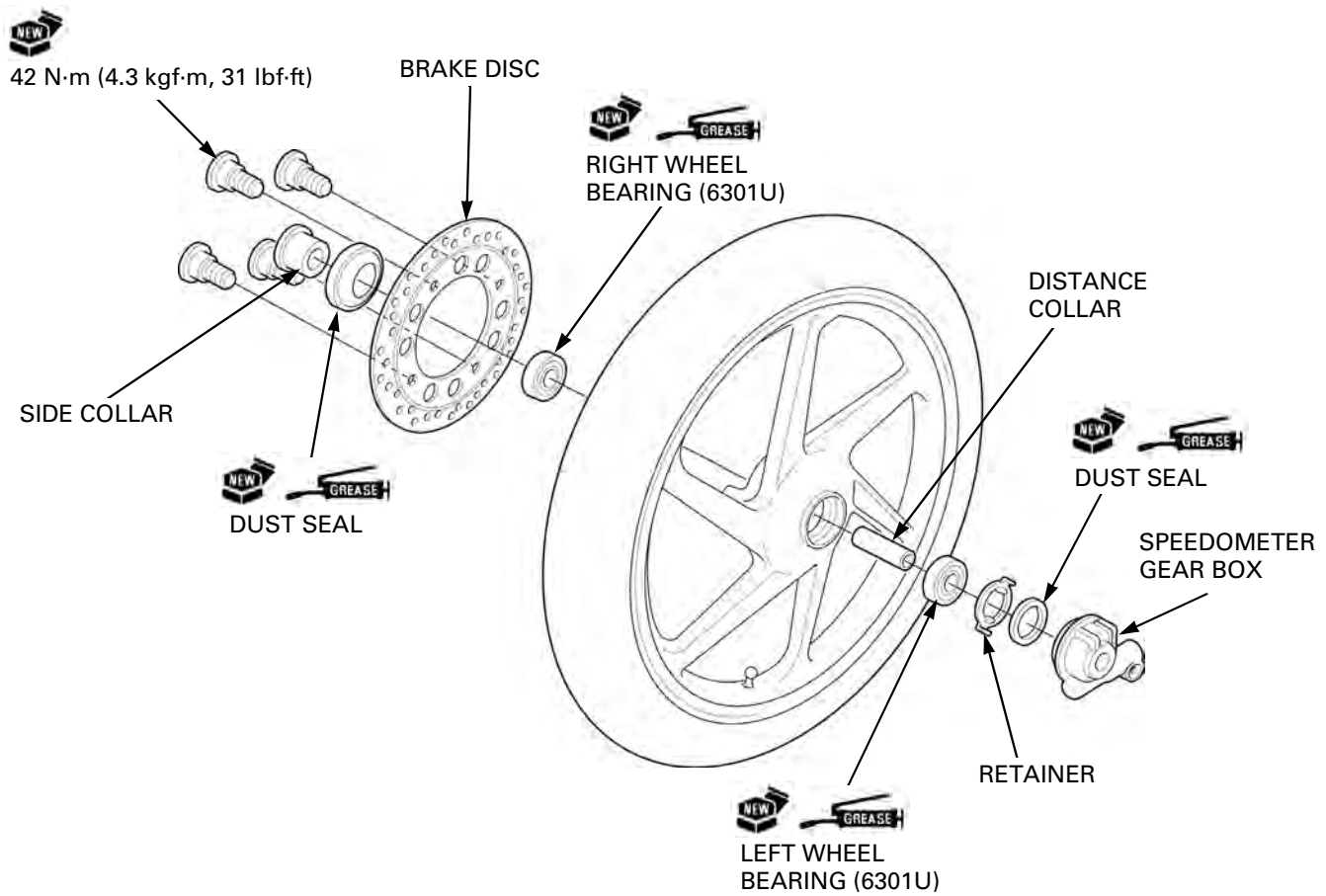

FRONT WHEEL/BRAKE/SUSPENSION/STEERING

WHEEL ASSEMBLY

Never install the old bearing, once the bearing has been removed, the bearing must be replaced with new ones.

Pack all bearing cavities with grease.
 Drive in a new right (brake disc side) bearing squarely with its sealed side facing up until it is fully seated.
 Install the distance collar.
 Drive in a new left bearing squarely with its sealed side facing up.

TOOLS:

Driver

07749-0010000

Attachment, 37 x 40 mm

07746-0010200

Pilot, 12 mm

07746-0040200

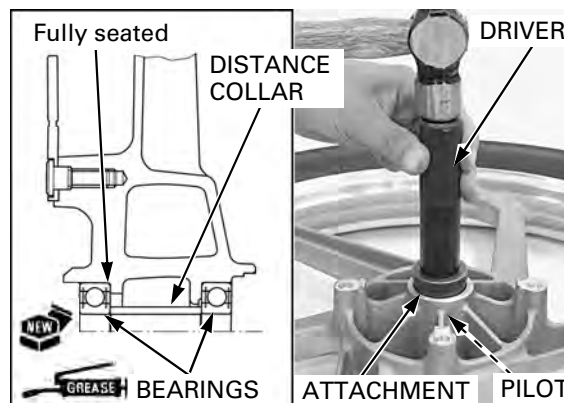

Do not get grease on the brake disc or stopping power will be reduced.

Install and tighten the new brake disc bolts in a crisscross pattern in 2 or 3 steps.

TORQUE: 42 N·m (4.3 kgf·m, 31 lbf·ft)

Apply grease to a new right dust seal lip.
 Install the dust seal to the right wheel hub.

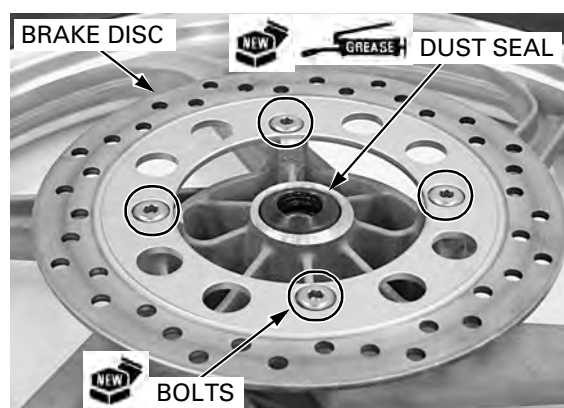

Install the speedometer gear retainer to the wheel hub, aligning the tabs on the retainer with the slots on the hub.

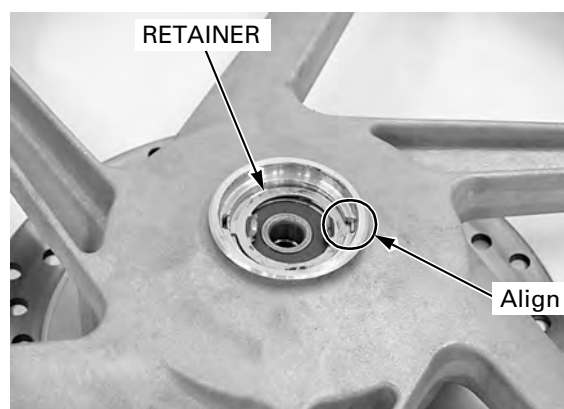

Apply grease to a new left dust seal lip.
 Install the dust seal to the left wheel hub.



FRONT WHEEL/BRAKE/SUSPENSION/STEERING

INSTALLATION

Install the speedometer gear box into the left wheel hub, aligning the tabs with the slots.

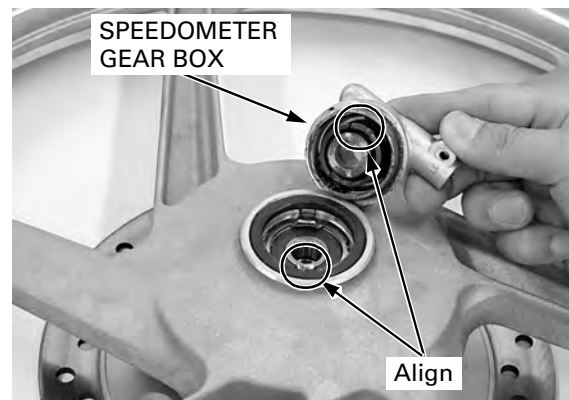

Install the side collar into the right wheel hub.



Be careful not to damage the pads.

Install the front wheel between the fork legs, aligning the speedometer gear box groove with the boss on the fork leg so that the brake disc is positioned between the pads.

Insert the front axle from the right fork leg.

Install and tighten the axle nut to the specified torque.

TORQUE: 52 N·m (5.3 kgf·m, 38 lbf·ft)

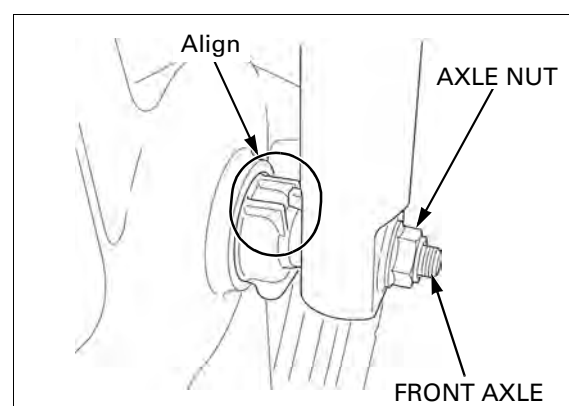

Install the speedometer cable to the speedometer gear box aligning slot of the cable and the tab of the gear box.

Install and tighten the screw.

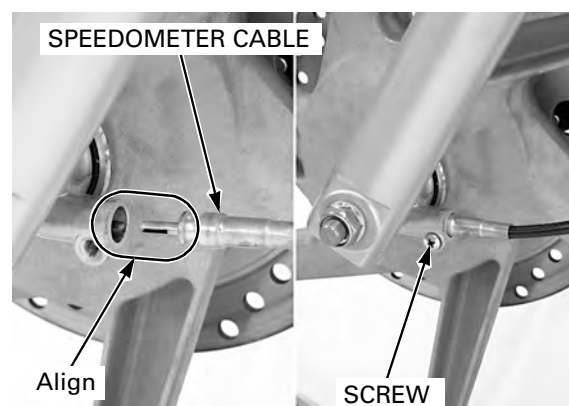

FRONT WHEEL/BRAKE/SUSPENSION/STEERING

FRONT DRUM BRAKE (TYPE: I, III)

INSPECTION

Remove the front wheel (page 12-11).

Measure the front brake drum I.D.

SERVICE LIMIT: 131.0 mm (5.16 in)

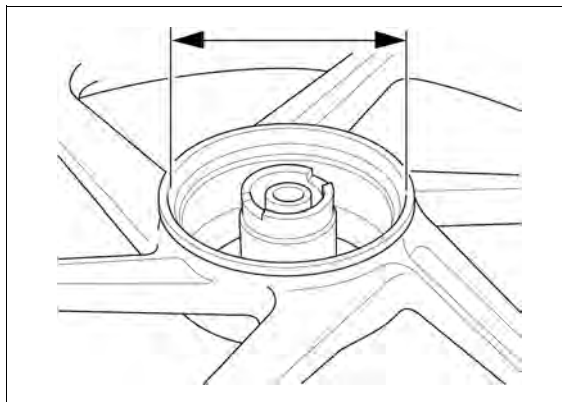

DISASSEMBLY

Remove the brake panel assembly (page 12-12).

Always replace the brake shoes in pairs.

Expand the brake shoes and remove them from the brake panel.

Remove the shoe springs from the brake shoes.

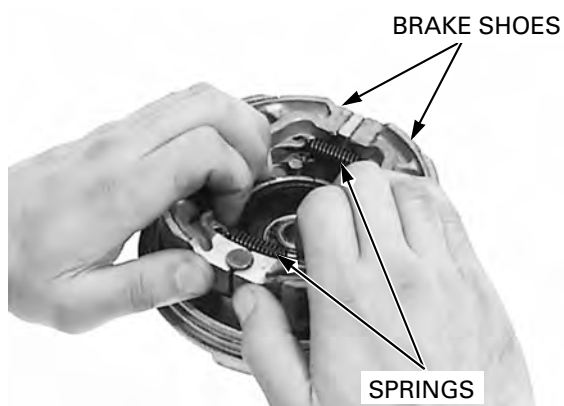

Remove the following:

- Nut and bolt
- Return spring (from the brake arm)
- Brake arm

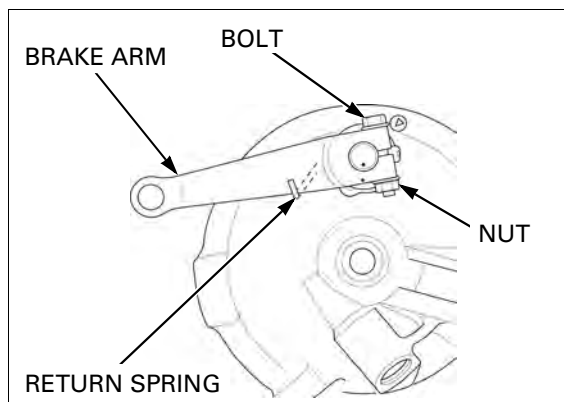

Remove the wear indicator.

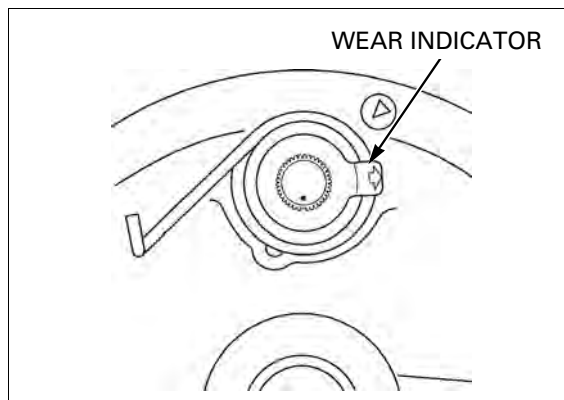

FRONT WHEEL/BRAKE/SUSPENSION/STEERING

Remove the following:

- Return spring
- Felt seal

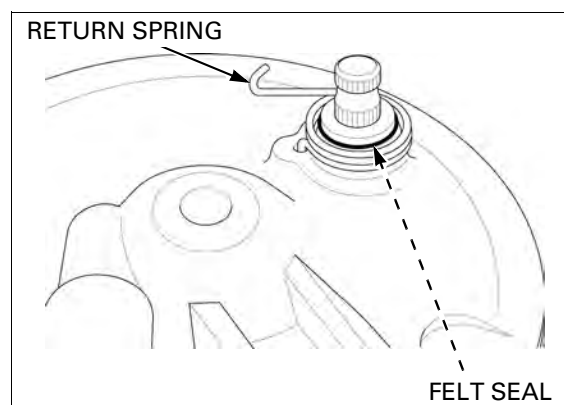

Remove the brake cam.

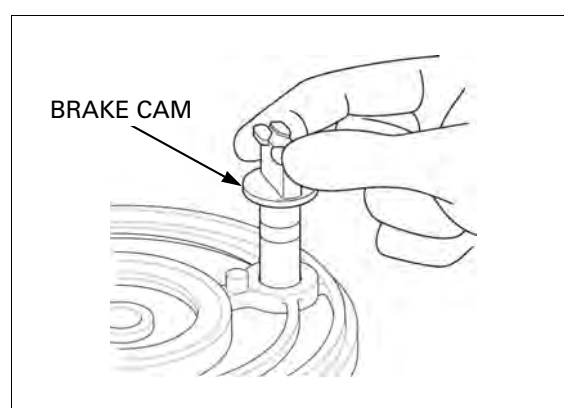

Remove the following:

- Dust seal
- Snap ring
- Washer

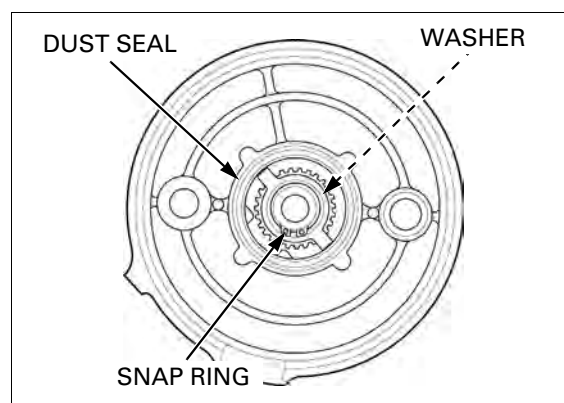

Remove the following:

- Speedometer gear
- Washer

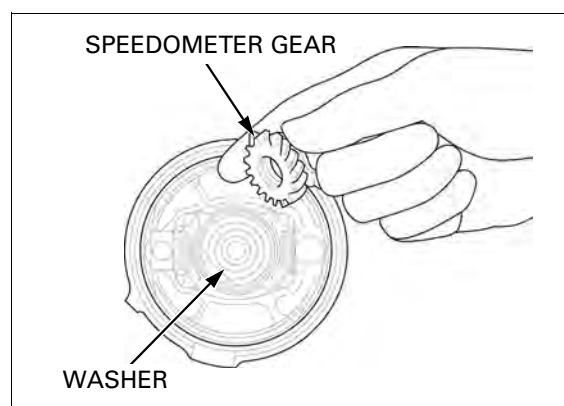

FRONT WHEEL/BRAKE/SUSPENSION/STEERING
ASSEMBLY

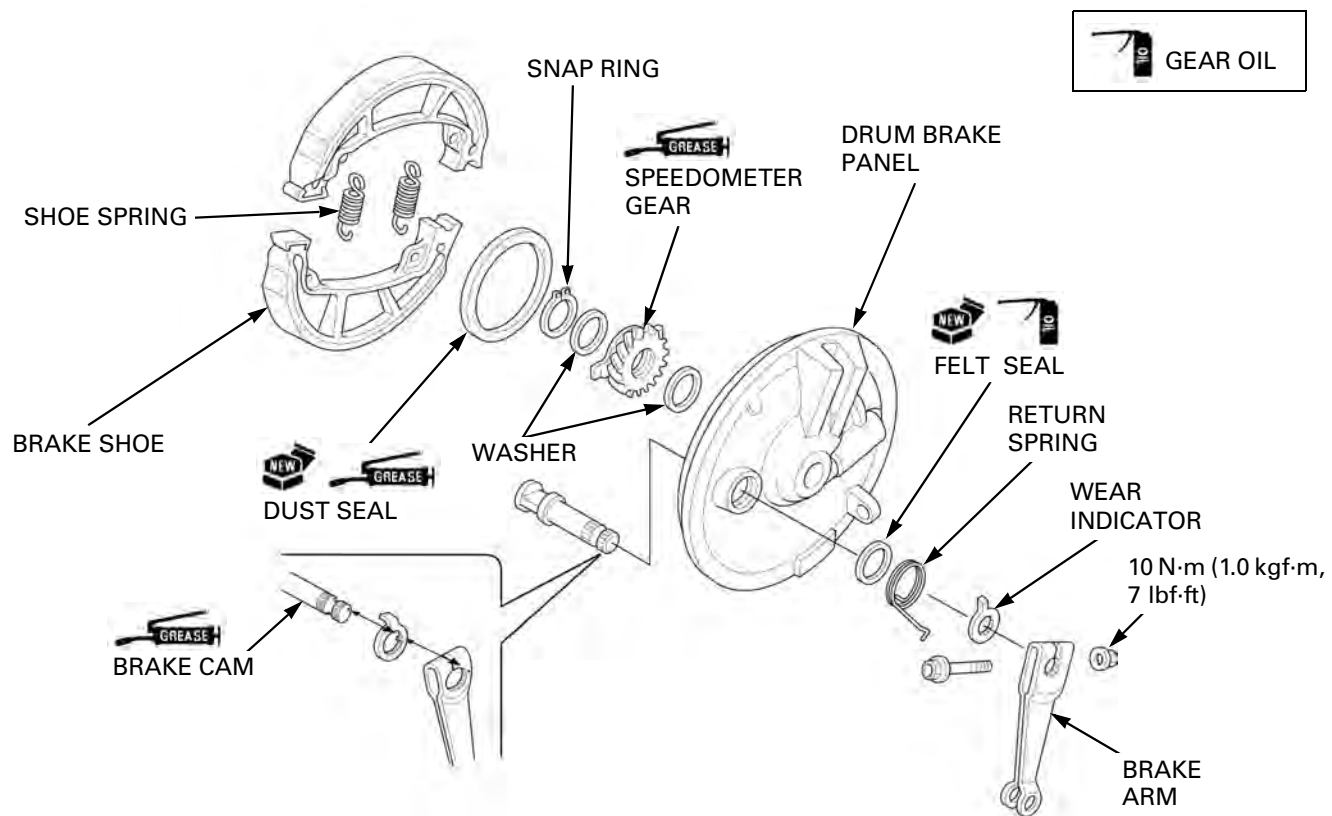

Apply grease to the speedometer gear.
 Install the washer and speedometer gear.

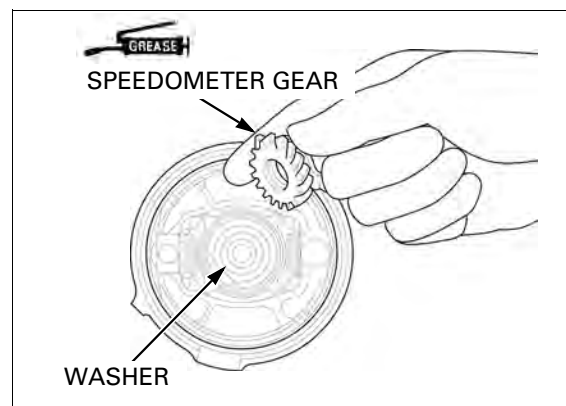

Install the washer and snap ring.
 Apply grease to a new dust seal lip.
 Install the dust seal to the brake panel.

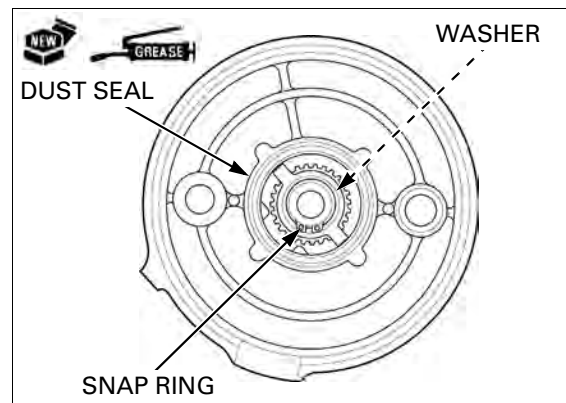

FRONT WHEEL/BRAKE/SUSPENSION/STEERING

Apply grease to the spindle groove in the brake cam.

Install the brake cam to the brake panel.

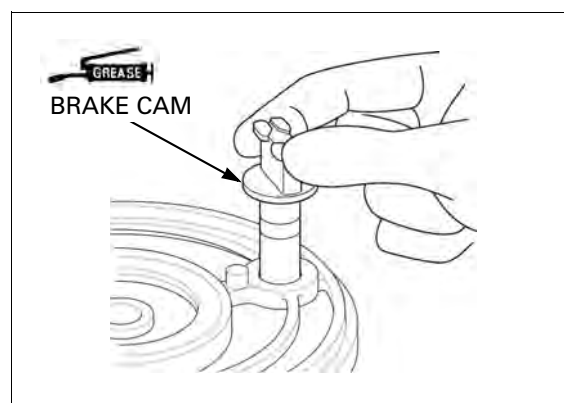

Apply gear oil to a new felt seal and install it.

Install the return spring to the brake panel.

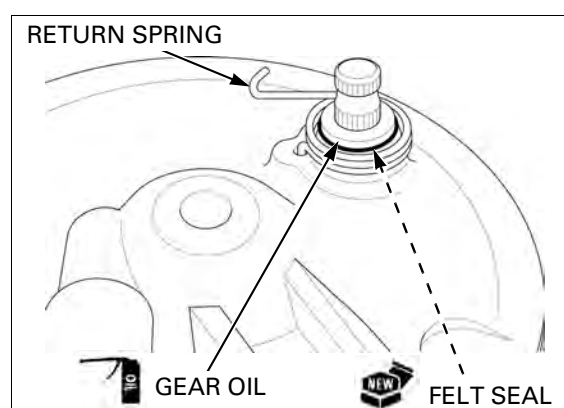

Install the wear indicator, aligning the wide tooth with the wide groove of the brake cam.

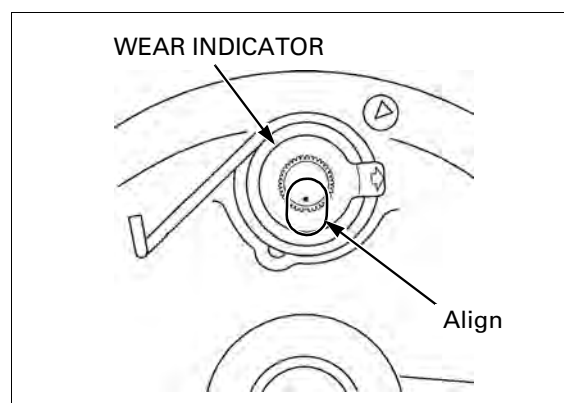

Install the brake arm, aligning the punch marks.

Install the bolt and nut, then tighten the nut.

TORQUE: 10 N·m (1.0 kgf·m, 7 lbf·ft)

Hook the return spring to the brake arm as shown.

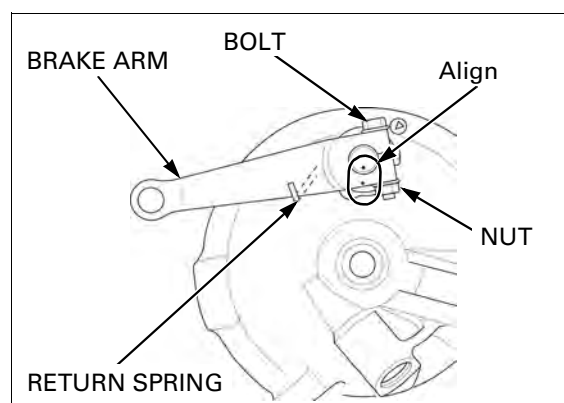

FRONT WHEEL/BRAKE/SUSPENSION/STEERING

Apply grease to the anchor pin and brake cam sliding surfaces.

Assemble the brake shoes and springs as shown. Install the shoe assembly onto the brake panel.

Wipe any excess grease from the brake cam and anchor pin.

Install the brake panel assembly (page 12-14).

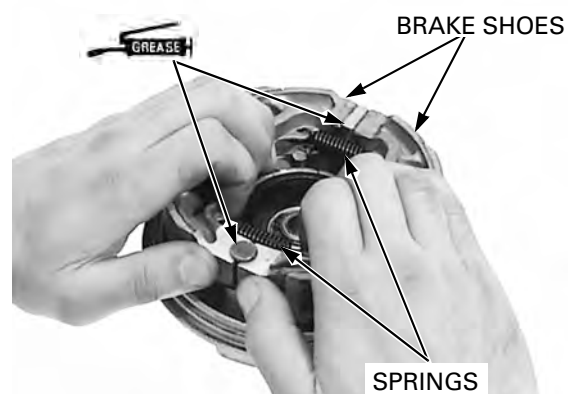

FORK

REMOVAL

Type II and IV: support the caliper so it does not hang from the brake hose. Do not twist the brake hose.

Remove the brake caliper (page 14-15).

Remove the following:

- Front cowl (page 2-7)
- Front wheel (type II and IV: page 12-15 or type I and III: page 12-11)
- Front fender (page 2-6)
- License plate holder (page 2-8)
- Combination meter unit (page 18-6)

Loosen the front cowl bracket bolts and slightly pull up the bracket.

Loosen the fork top pinch bolts.

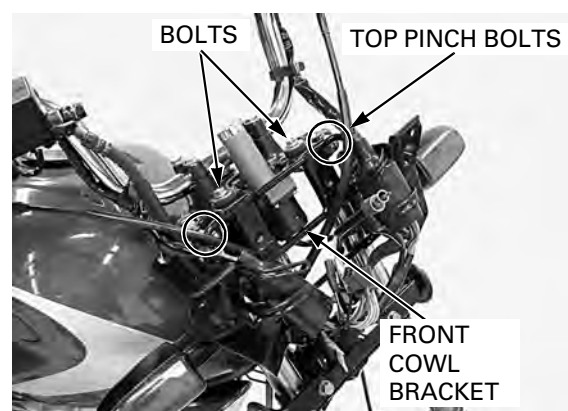

If the fork will be disassembled, loosen the fork cap when bottom pinch bolts fastened while having removed fork downward.

Loosen the fork bottom pinch bolts and pull out the fork pipe.

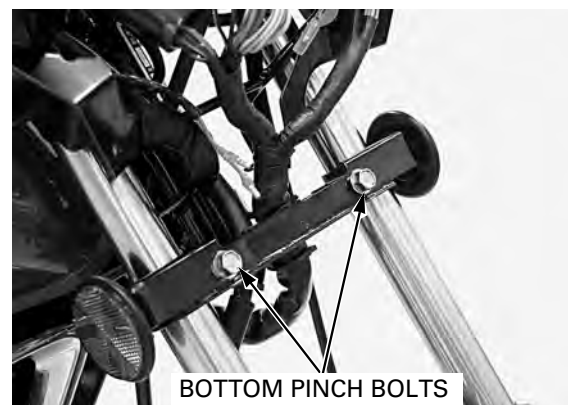

DISASSEMBLY

Remove the fork cap and O-ring.



FRONT WHEEL/BRAKE/SUSPENSION/STEERING

Remove the fork spring.

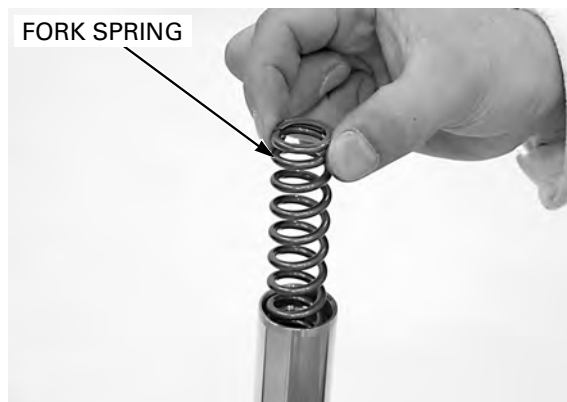

Drain the fork fluid by pumping the fork pipe several times.



Remove the dust seal.

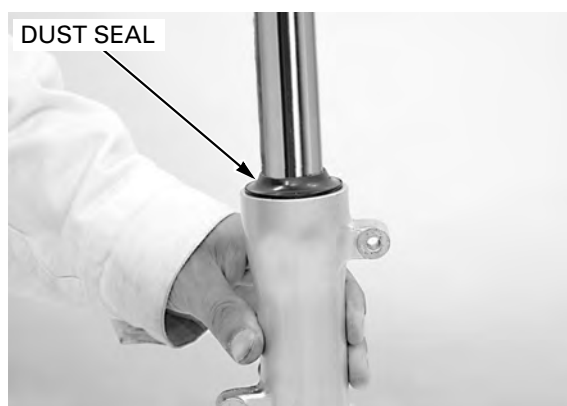

Be careful not to scratch the fork pipe. Remove the oil seal stopper ring.



FRONT WHEEL/BRAKE/SUSPENSION/STEERING

Hold the fork slider in a vise with pieces of wood or shop towel.

If the fork piston turns with the socket bolt, temporarily install the fork spring and fork cap.
Remove the fork socket bolt and sealing washer.

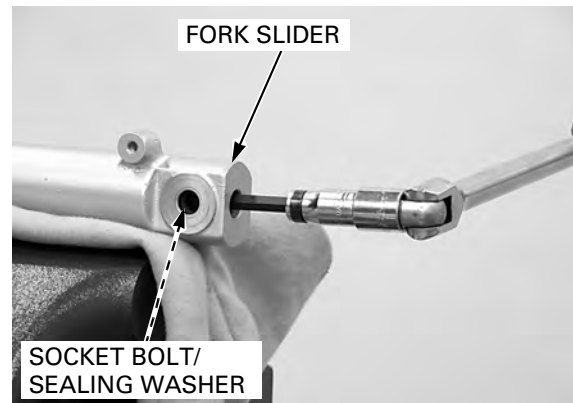

Remove the fork pipe from the fork slider.
Remove the oil lock piece from the fork slider.

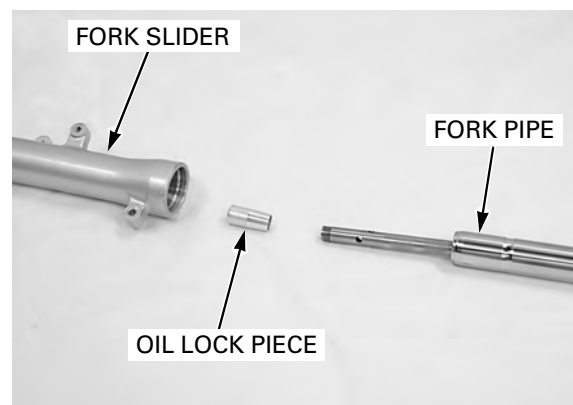

Remove the fork piston and rebound spring from the fork pipe.

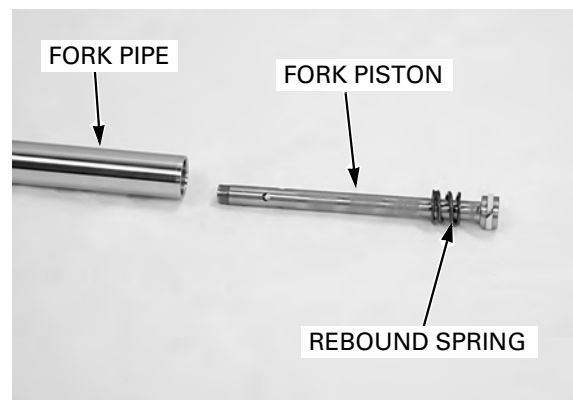

Remove the oil seal using the oil seal remover.

TOOL:
Oil seal remover 07748-0010001



FRONT WHEEL/BRAKE/SUSPENSION/STEERING

Remove the back-up ring from the fork slider.

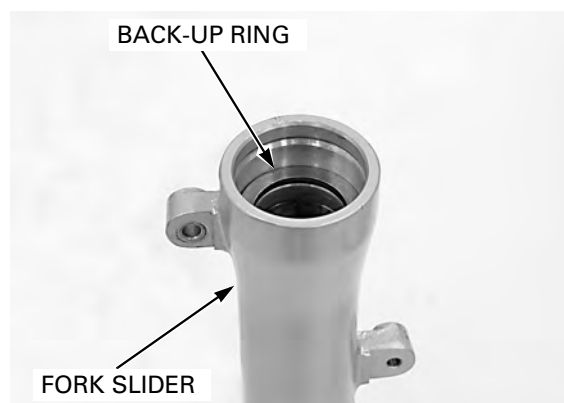

INSPECTION

FORK SPRING

Check the fork spring for fatigue or damage.

Measure the fork spring free length.

SERVICE LIMIT: 457.2 mm (18.0 in)

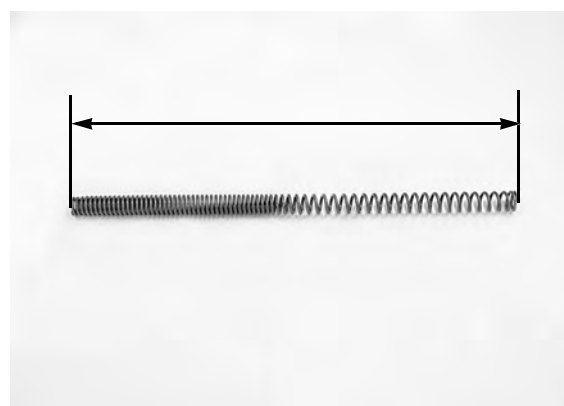

FORK PIPE/SLIDER

Check the fork pipe and slider for score marks, scratches, or excessive or abnormal wear.

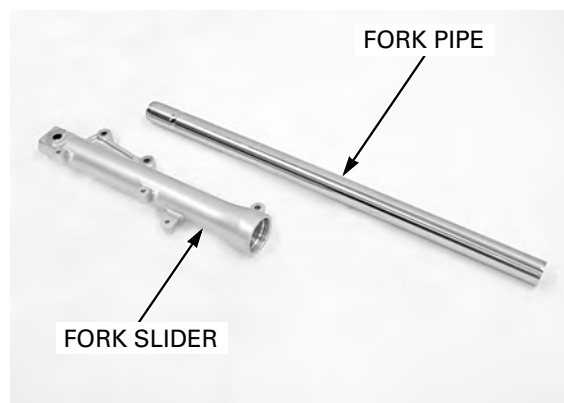

Set the fork pipe in V-blocks and read the runout with a dial indicator.

The actual runout is 1/2 of the total indicator reading.

SERVICE LIMIT: 0.20 mm (0.008 in)

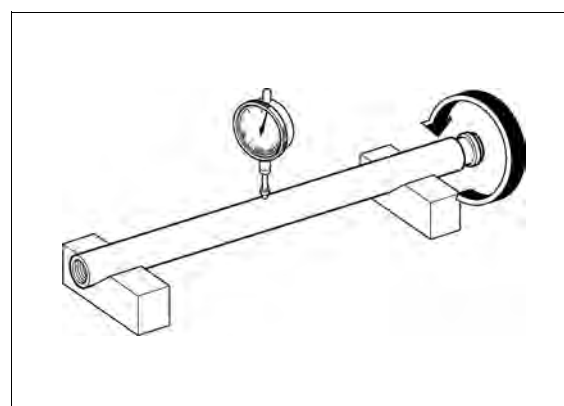

FRONT WHEEL/BRAKE/SUSPENSION/STEERING

FORK PISTON

Check the fork piston for score marks, scratches, or excessive or abnormal wear.

Check the rebound spring for fatigue or damage.

Check the piston ring for wear or damage.

Replace the front fork assembly if any components are worn or damaged.

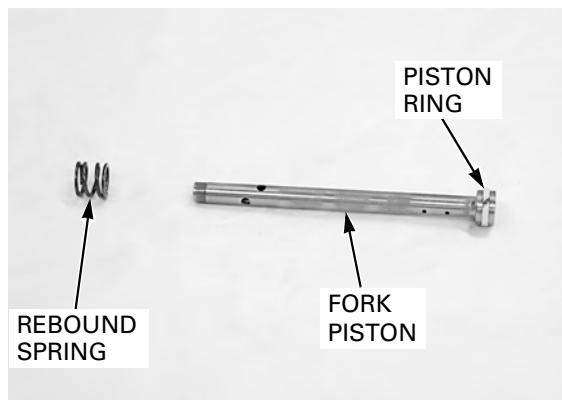

FORK PIPE BUSHING/BACK-UP RING

Visually inspect the slider bushing.

Replace the fork slider if they are worn, or if the Teflon coating is worn and 3/4 or over of the copper surface appears.

Check the back-up ring and replace it if there is any distortion at the points indicated by arrows on the figure.

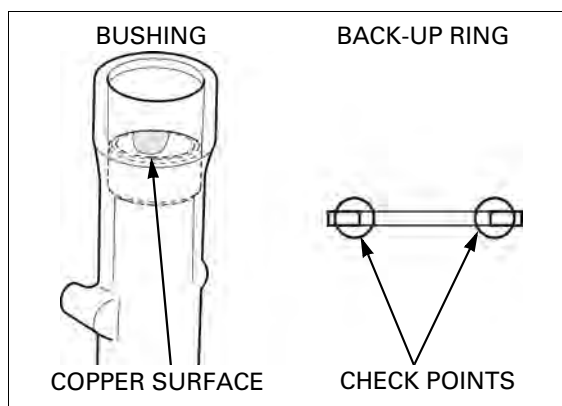

ASSEMBLY

Before assembly, wash all parts with a high flash point or non-flammable solvent and wipe them dry.

Install the rebound spring and fork piston into the fork pipe.

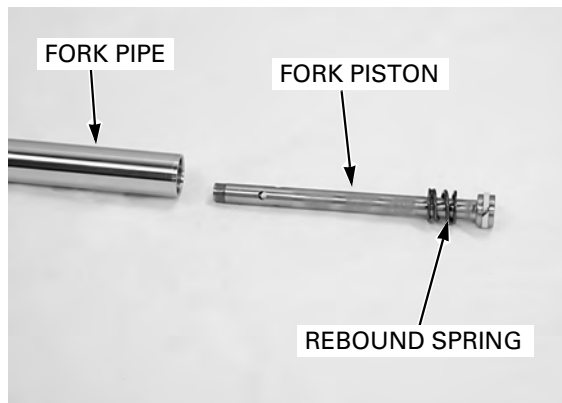

Install the oil lock piece onto the fork piston end. Apply fork fluid to the slider bushing surface. Install the fork pipe into the fork slider.

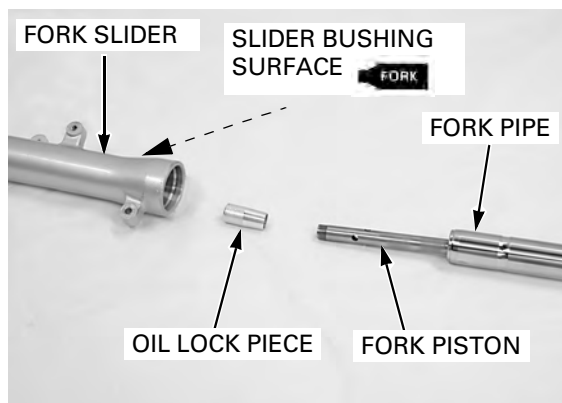

FRONT WHEEL/BRAKE/SUSPENSION/STEERING

Clean the socket bolt threads and apply a locking agent to the fork socket bolt threads and install it with a new sealing washer.

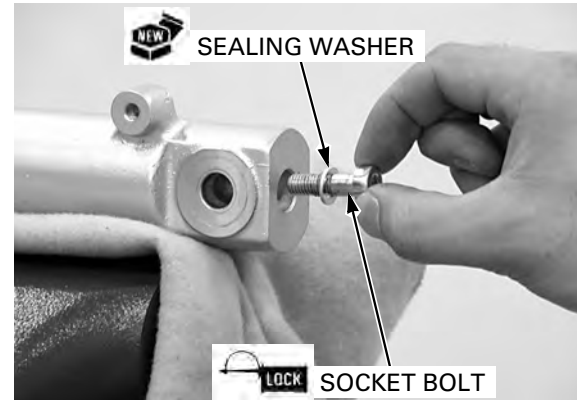

Hold the fork slider in a vise with pieces of wood or a shop towel.

If the fork piston turns with the socket bolt, temporarily install the fork spring and fork cap.

Tighten the socket bolt.

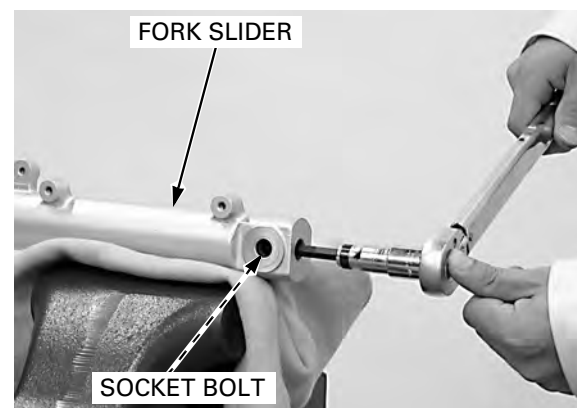

Install the back-up ring into the fork slider.

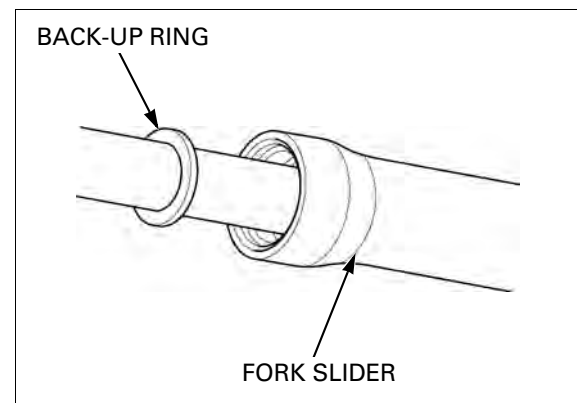

Apply fork fluid to a new oil seal lips, then install it into the fork slider. Drive the oil seal into the fork slider using the special tools.

TOOLS:

Fork seal driver 07747-0010100
Fork seal driver attachment 07747-0010400

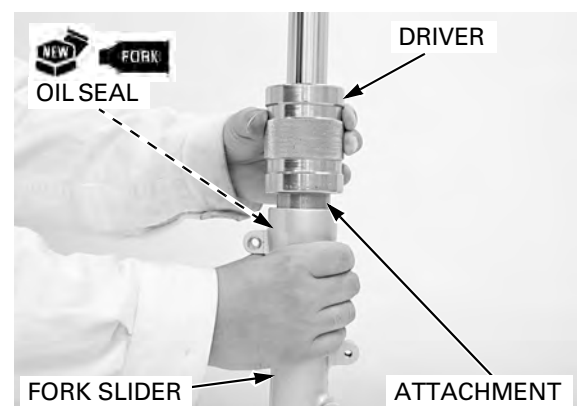

FRONT WHEEL/BRAKE/SUSPENSION/STEERING

Install the oil seal stopper ring into the groove of the fork slider.

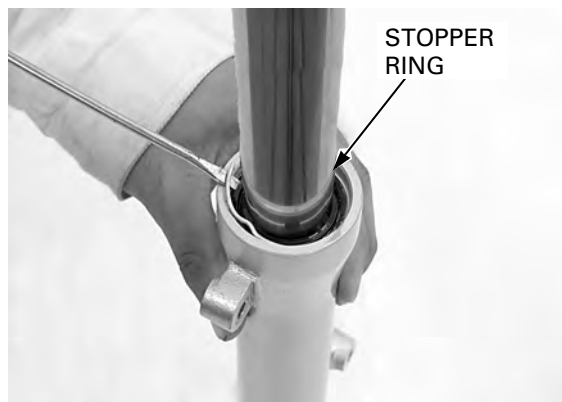

Install a new dust seal.



Pour the specified amount of recommended fork fluid into the fork pipe.

RECOMMENDED FLUID: Fork fluid

FORK FLUID CAPACITY:
65.0 cm³ (2.20 US oz, 2.29 Imp oz)

Pump the fork pipe several times to remove trapped air from the lower portion of the fork pipe.

Compress the fork leg fully and measure the oil level from the top of the fork pipe.

FLUID LEVEL: 159 mm (6.26 in)

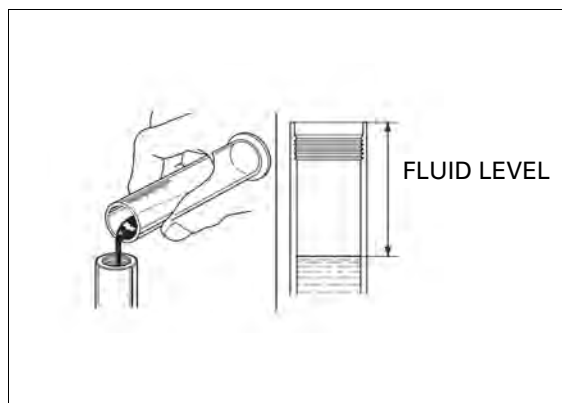

Pull the fork pipe up and install the fork spring with its narrow pitched end facing down.

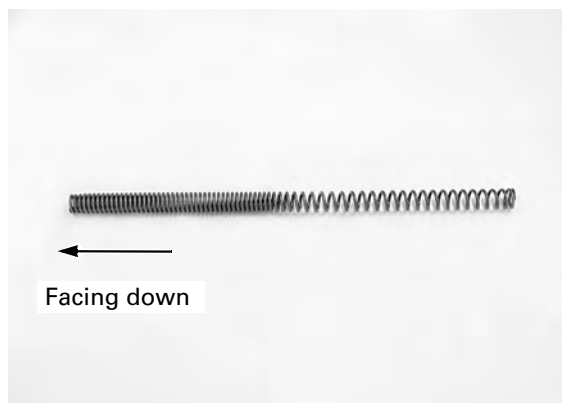

FRONT WHEEL/BRAKE/SUSPENSION/STEERING

Apply fork fluid to a new O-ring and install it onto the fork cap.

Tighten the fork cap after installing the fork pipe into the fork bridges.

Install the fork cap onto the fork pipe.

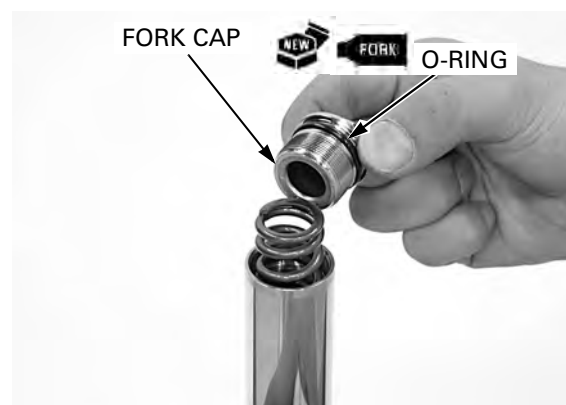

INSTALLATION

Insert the fork pipes into the bottom bridge.

Align the top end of the fork pipes with the upper surface of the top bridge as shown.

Tighten the bottom pinch bolts to the specified torque.

TORQUE: 34 N·m (3.5 kgf·m, 25 lbf·ft)

Tighten the fork caps to the specified torque.

TORQUE: 22 N·m (2.2 kgf·m, 16 lbf·ft)

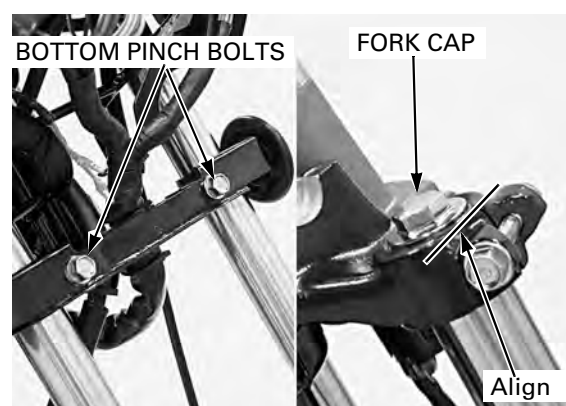

Tighten the top pinch bolts to the specified torque.

TORQUE: 23 N·m (2.3 kgf·m, 17 lbf·ft)

Reposition the front cowl bracket and tighten the bolts.

Install the following:

- Combination meter unit (page 18-6)
- License plate holder (page 2-8)
- Front fender (page 2-6)
- Front wheel (type II and IV: page 12-19 or type I and III: page 12-14)
- Front cowl (page 2-7)

Type II and IV: Install the brake caliper (page 14-18).

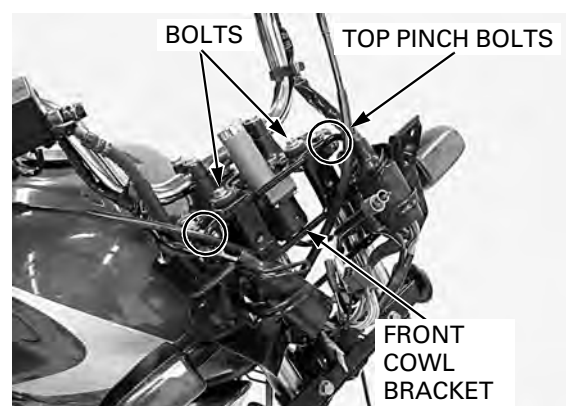

STEERING STEM

REMOVAL

Remove the following:

- Front wheel (type II and IV: page 12-15 or type I and III: page 12-11)
- Front cowl (page 2-7)
- Combination meter (page 18-6)

Remove the bolts and front cowl bracket.

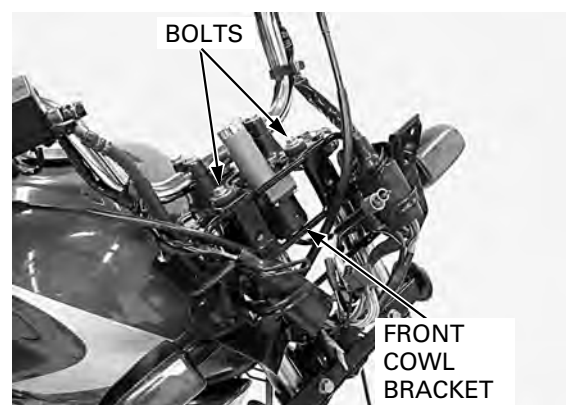

FRONT WHEEL/BRAKE/SUSPENSION/STEERING

Remove the bottom pinch bolts and side reflector stay.

Type II and IV: Remove the brake hose holder from the bottom bridge.

Remove the handlebar (page 12-7).

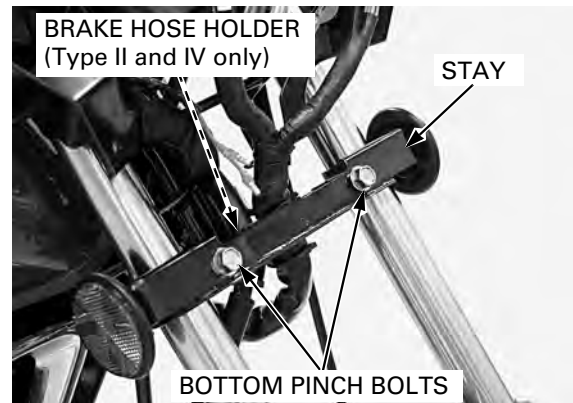

Loosen the steering stem nut.



Remove the fork (page 12-24).

Remove the steering stem nut, washer and top bridge.

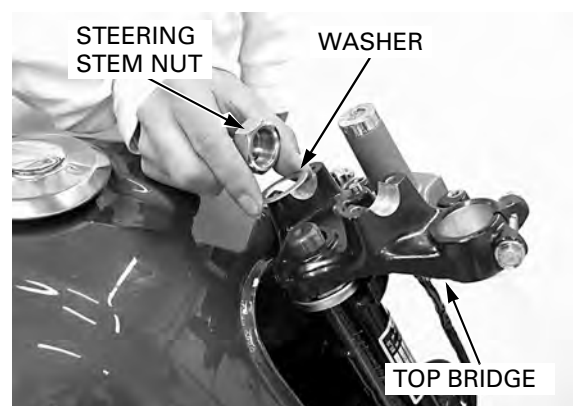

Loosen the adjusting nut using the special tool.

TOOL:

Stem socket wrench

07916-3710101



FRONT WHEEL/BRAKE/SUSPENSION/STEERING

When removing the adjusting nut, hold the steering stem.

Remove the adjusting nut.



Remove the following:

- Top cone race
- Upper steel balls (21)

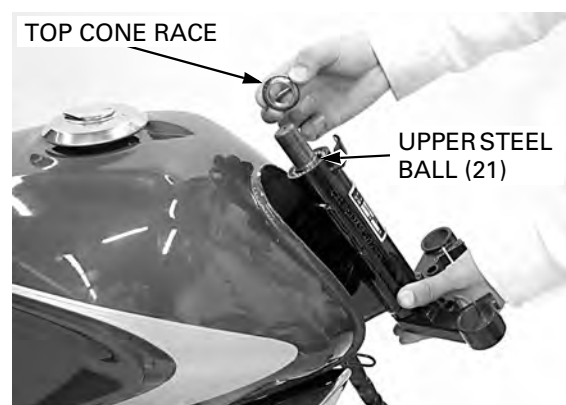

Remove the following:

- Steering stem
- Lower steel balls (21)

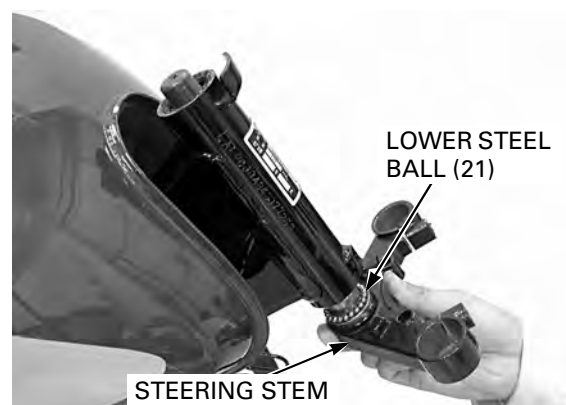

BALL RACE REPLACEMENT

Remove the ball races using the special tool.

TOOL:

Ball race remover

07944-1150001

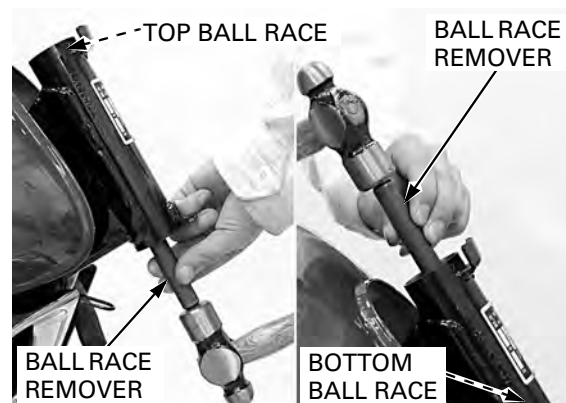

FRONT WHEEL/BRAKE/SUSPENSION/STEERING

Install a new top ball race using the special tools.

TOOLS:
Driver 07749-0010000
Attachment, 37 x 40 mm 07746-0010200

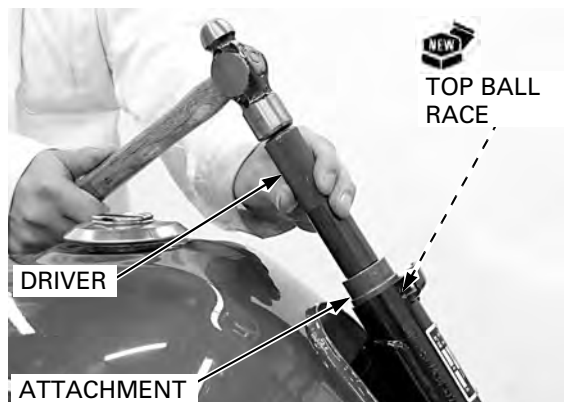

Install a new bottom ball race using the special tools.

TOOLS:
Driver 07749-0010000
Attachment, 37 x 40 mm 07746-0010200

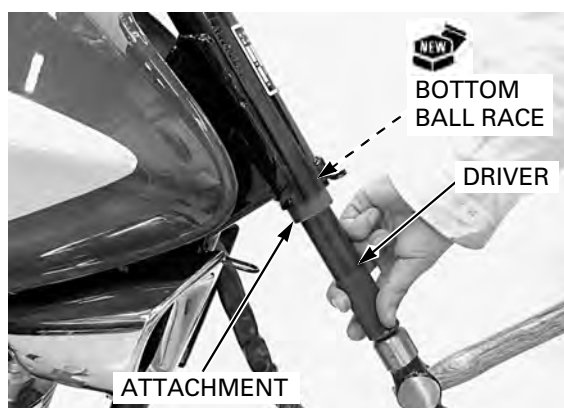

BOTTOM CONE RACE REPLACEMENT

To avoid damaging the steering stem thread, temporarily install the stem nut. Remove the bottom cone race, washer and dust seal.

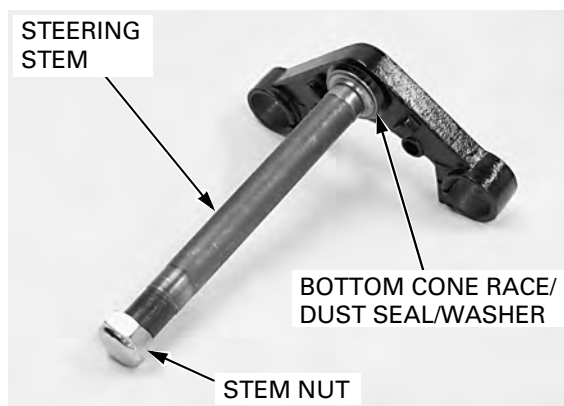

Install the washer and new dust seal. Press a new bottom cone race onto the steering stem using the special tool.

TOOL:
Steering stem driver 07946-GC40000

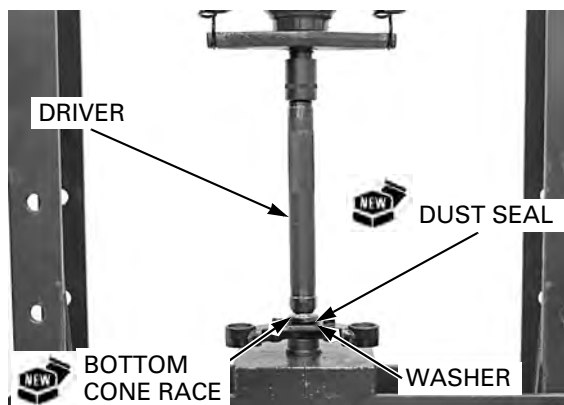

FRONT WHEEL/BRAKE/SUSPENSION/STEERING

INSTALLATION

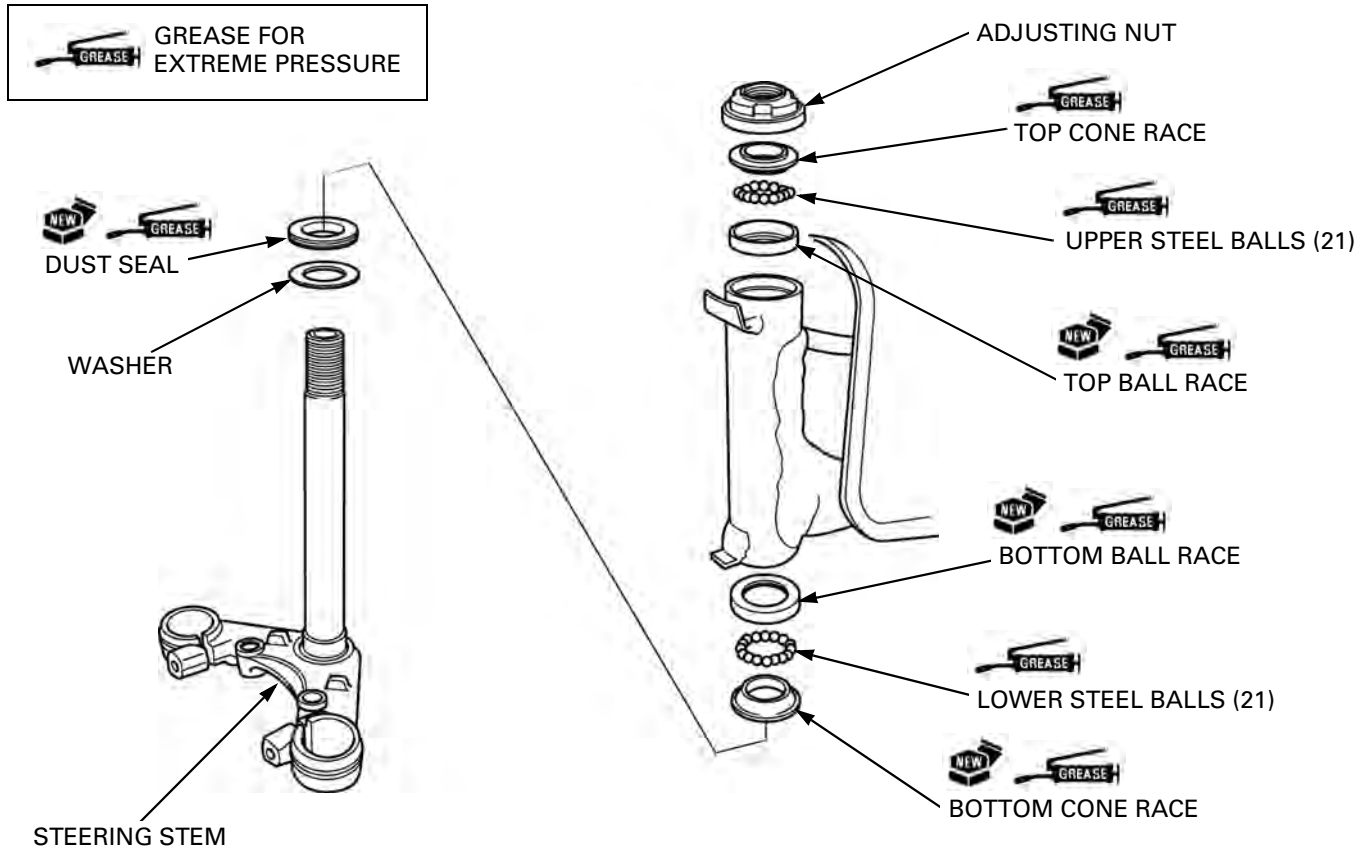

Apply grease for extreme pressure to bearing area and dust seal lip.
Install the lower steel balls (21) in the bottom cone race.

Install the steering stem.

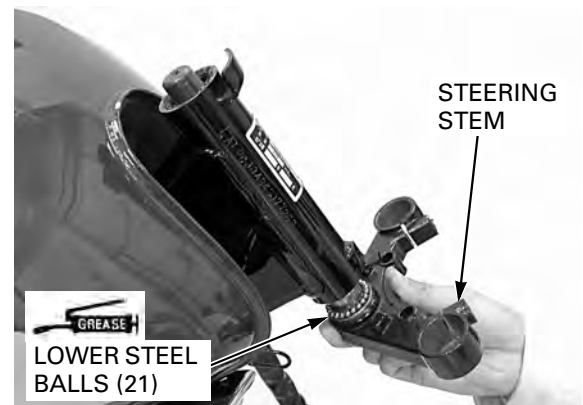

Apply grease for extreme pressure to bearing area.
Install the upper steel balls (21) in the top ball race.
Install the top cone race.



FRONT WHEEL/BRAKE/SUSPENSION/STEERING

Install the adjusting nut.



Tighten the adjusting nut to the specified torque.

TOOL:

Stem socket wrench **07916-3710101**

TORQUE: 25 N·m (2.5 kgf·m, 18 lbf·ft)



Turn the steering stem left and right several times.



Temporarily loosen the adjusting nut completely, then retighten the adjusting nut to the specified torque.

TOOL:

Stem socket wrench **07916-3710101**

TORQUE: 3.0 N·m (0.3 kgf·m, 2.2 lbf·ft)

Check that there is no vertical play and that the steering stem rotates smoothly.



FRONT WHEEL/BRAKE/SUSPENSION/STEERING

Install the top bridge.
Install the washer and steering stem nut.

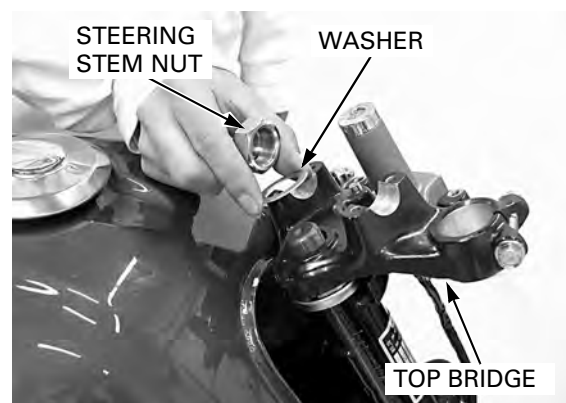

Loosen the bottom pinch bolts when tightening the stem nut.

Install the fork (page 12-31).
Tighten the steering stem nut to the specified torque.
TORQUE: 74 N·m (7.5 kgf·m, 55 lbf·ft)

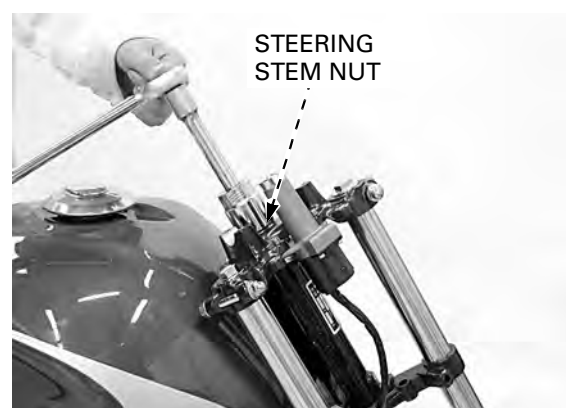

Install the handlebar (page 12-9).
Type II and IV: Install the brake hose holder to the bottom bridge.
Install the side reflector stay and tighten the bottom pinch bolts.
TORQUE: 34 N·m (3.5 kgf·m, 25 lbf·ft)

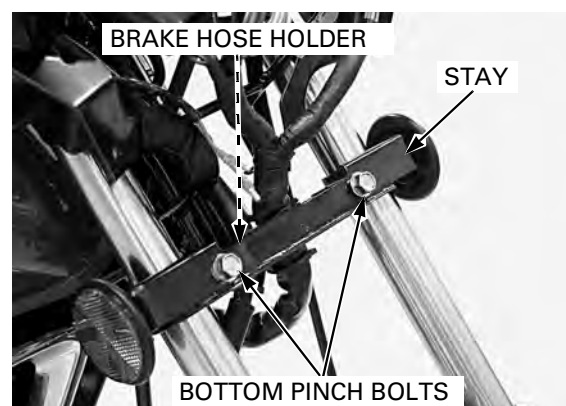

Install the front cowl bracket and tighten the bolts.
Install the following:
– Combination meter (page 18-6)
– Front cowl (page 2-7)
– Front wheel (type II and IV: page 12-19 or type I and III: page 12-14)

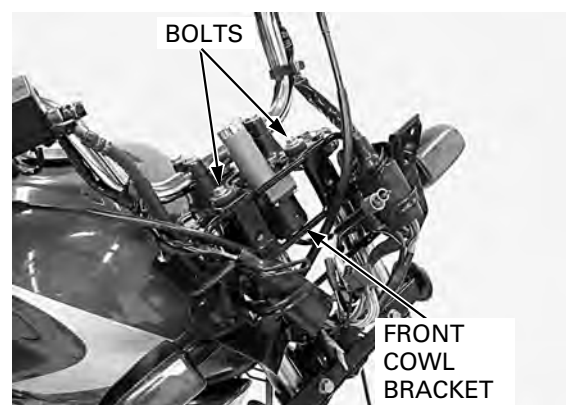

FRONT WHEEL/BRAKE/SUSPENSION/STEERING

STEERING BEARING PRELOAD

Raise the front wheel off the ground.
Position the steering stem to the straight ahead position.
Hook a spring scale to the fork pipe between the fork top and bottom bridges.
Make sure that there is no cable or wire harness interference.
Pull the spring scale keeping the scale at a right angle to the steering stem.
Read the scale at the point where the steering stem just starts to move.

STEERING BEARING PRE-LOAD:

1.6 – 2.4 kgf (3.53 – 5.29 lbf)

If the readings do not fall within the limits, readjust the steering top thread.

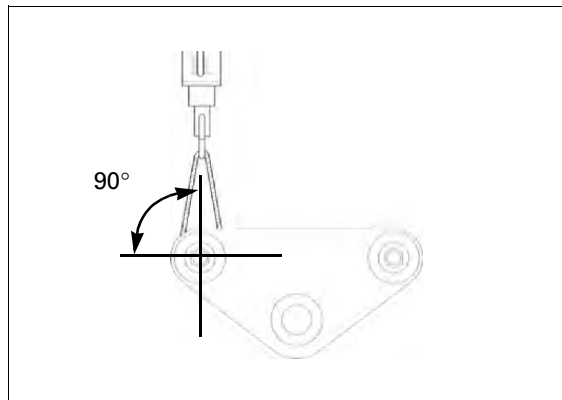

13. REAR WHEEL/BRAKE/SUSPENSION

SYSTEM COMPONENTS	13-2	REAR DRUM BRAKE	13-13
SERVICE INFORMATION	13-3	BRAKE PEDAL/CENTER STAND	13-16
TROUBLESHOOTING	13-5	SHOCK ABSORBER	13-20
REAR WHEEL	13-6	SWINGARM	13-21

**REAR WHEEL/BRAKE/SUSPENSION
SYSTEM COMPONENTS**

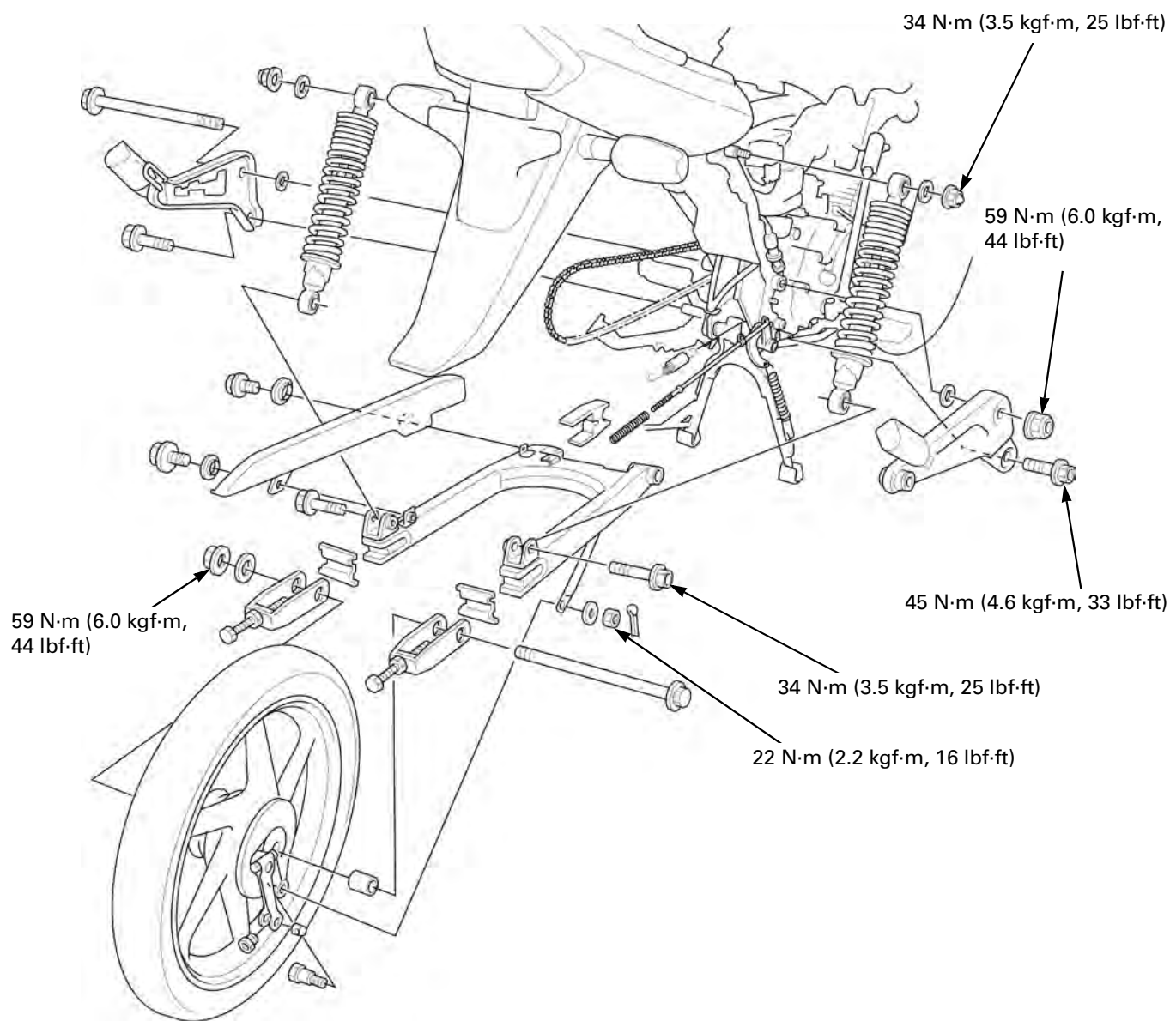

SERVICE INFORMATION

GENERAL

⚠ CAUTION

Frequent inhalation of brake shoe dust, regardless of material composition could be hazardous to your health.

- Avoid breathing dust particles.
- Never use an air hose or brush to clean brake assemblies. Use an OSHA-approved vacuum cleaner.

- When servicing the rear wheel and suspension, support the motorcycle using a safety stand or hoist.
- Use genuine Honda replacement bolts and nuts for all suspension pivots and mounting points.

SPECIFICATIONS

Unit: mm (in)







ITEM		STANDARD	SERVICE LIMIT
Minimum tire tread depth		–	To wear indicator
Cold tire pressure	Driver only	225 kPa (2.25 kgf/cm ² , 33 psi)	–
	Driver and passenger	225 kPa (2.25 kgf/cm ² , 33 psi)	–
Axle runout		–	0.2 (0.01)
Wheel rim runout	Radial	–	1.0 (0.04)
	Axial	–	1.0 (0.04)
Drive chain	Size/link	428/108	–
	Slack	10 – 20 (0.4 – 0.8)	–
Brake	Pedal free play	20 – 30 (0.8 – 1.2)	–
	Drum I.D.	130.0 – 130.3 (5.12 – 5.13)	131.0 (5.16)

TORQUE VALUES

Driven sprocket bolt	34 N·m (3.5 kgf·m, 25 lbf·ft)	
Rear axle nut	59 N·m (6.0 kgf·m, 44 lbf·ft)	
Rear brake arm nut	10 N·m (1.0 kgf·m, 7 lbf·ft)	U-nut
Rear brake stopper arm nut (swingarm side)	22 N·m (2.2 kgf·m, 16 lbf·ft)	
Rear brake stopper arm nut (rear brake panel side)	22 N·m (2.2 kgf·m, 16 lbf·ft)	
Shock absorber upper mounting nut	34 N·m (3.5 kgf·m, 25 lbf·ft)	
Shock absorber lower mounting bolt	34 N·m (3.5 kgf·m, 25 lbf·ft)	
Pillion step bracket bolt	45 N·m (4.6 kgf·m, 33 lbf·ft)	
Swingarm pivot nut	59 N·m (6.0 kgf·m, 44 lbf·ft)	

REAR WHEEL/BRAKE/SUSPENSION

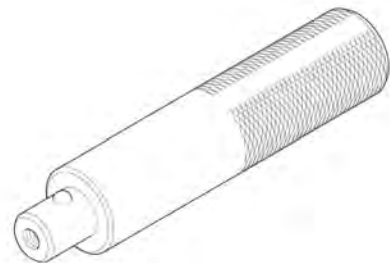
TOOLS

<p>Pilot, 15 mm 07746-0040300</p> 	<p>Pilot, 20 mm 07746-0040500</p> 	<p>Attachment, 22 x 24 mm 07746-0010800</p> 
<p>Attachment, 32 x 35 mm 07746-0010100</p> 	<p>Attachment, 42 x 47 mm 07746-0010300</p> 	<p>Driver 07749-0010000</p> 
<p>Bearing remover shaft 07746-0050100</p> 	<p>Bearing remover head, 15 mm 07746-0050400</p> 	

TROUBLESHOOTING

Rear wheel wobbles

- Bent rim
- Worn or damaged rear wheel bearings
- Faulty rear tire
- Worn or damaged swingarm bushings
- Bent frame or swingarm
- Axle fastener not tightened properly
- Tire pressure too low

Wheel turns hard

- Brake drag
- Faulty wheel bearings
- Bent axle
- Drive chain too tight (page 3-12)

Soft suspension

- Incorrect suspension adjustment
- Weak shock absorber springs
- Oil leakage from damper unit
- Low tire pressure

Hard suspension

- Incorrect suspension adjustment
- Bent shock absorber damper rod
- Damaged suspension or swingarm pivot bushings
- Bent swingarm pivot or frame
- High tire pressure

Steers to one side or does not track straight

- Drive chain adjusters not adjusted equally
- Bent axle
- Bent frame
- Worn swingarm pivot components

Rear suspension noise

- Loose suspension fasteners
- Worn or damaged suspension pivot bushings
- Faulty shock absorber

REAR WHEEL/BRAKE/SUSPENSION

REAR WHEEL

REMOVAL

Raise the rear wheel off the ground by placing a work stand or box under the frame.

Disconnect the brake rod by removing the adjusting nut, and remove the spring and joint pin.

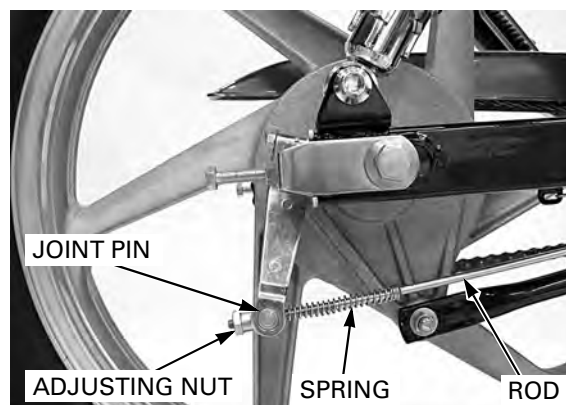

Remove the following:

- Cotter pin
- Nut
- Washer
- Joint bolt
- Brake panel stopper arm

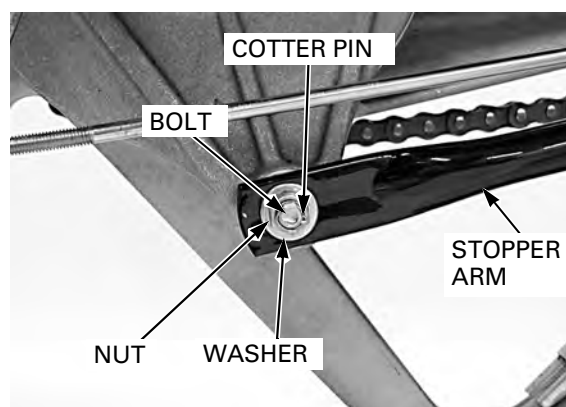

Loosen the axle nut.

Loosen the both drive chain adjuster lock nuts and adjusting bolts so the wheel can be moved all the way forward. Move the wheel forward for maximum chain slack.

Derail the drive chain from the driven sprocket.

Remove the following:

- Axle nut
- Axle
- Both adjusters and adjuster plates
- Collar
- Rear wheel

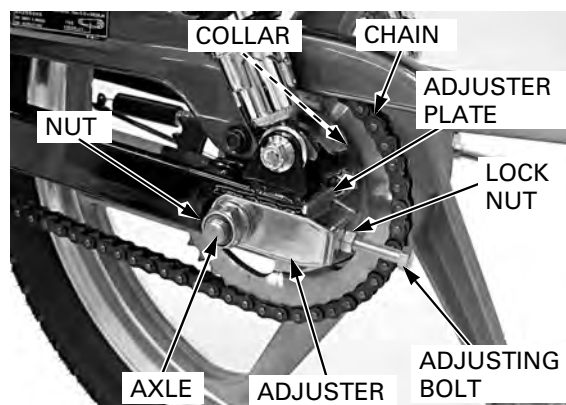

Remove the brake panel assembly.

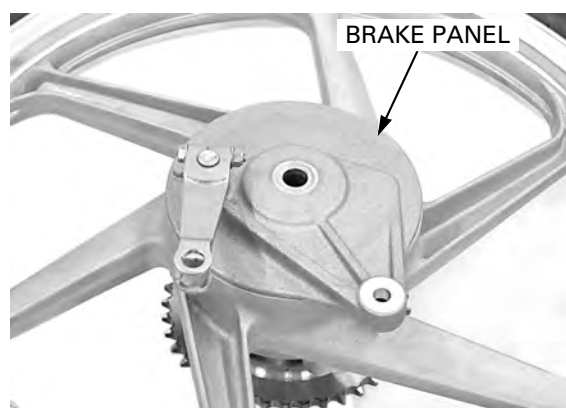

REAR WHEEL/BRAKE/SUSPENSION

Remove the side collar.

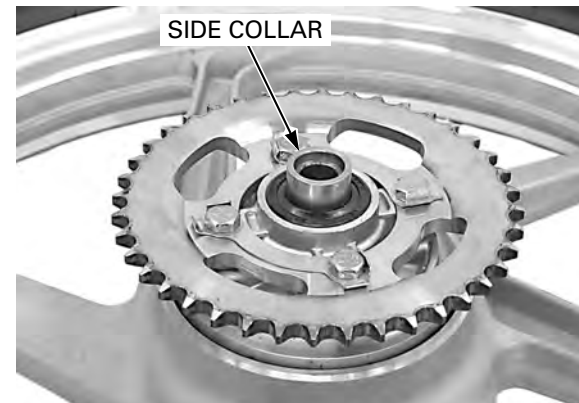

INSPECTION

AXLE

Set the axle in V-blocks. Turn the axle and measure the runout using a dial indicator. Actual runout is 1/2 the total indicator reading.

SERVICE LIMIT: 0.2 mm (0.01 in)

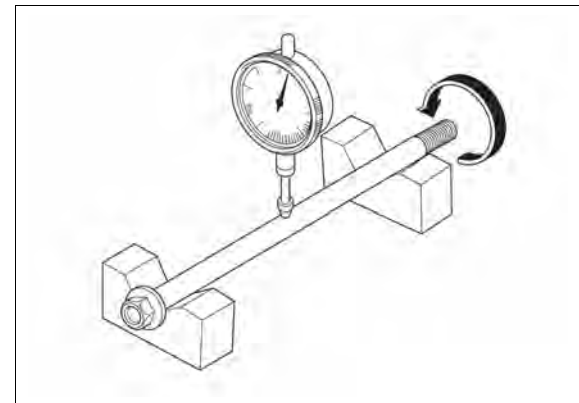

WHEEL BEARING

Turn the inner race of each bearing with your finger. The bearings should turn smoothly and quietly. Also check that the bearing outer race fits tightly in the hub.

Replace the bearings in pairs.

Remove and discard the bearings if they do not turn smoothly, quietly, or if they fit loosely in the hub.

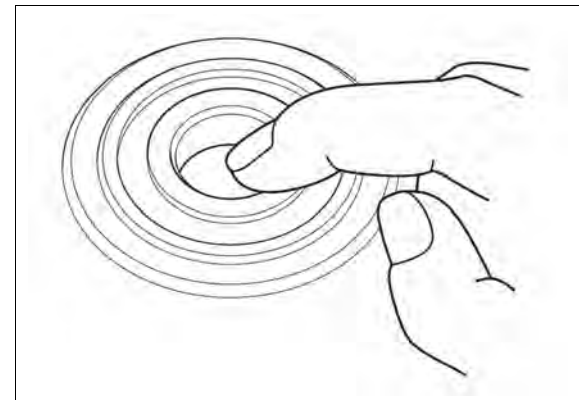

WHEEL RIM

Check the rim runout by placing the wheel in a turning stand. Spin the wheel by hand, and read the runout using a dial indicator.

SERVICE LIMIT:

Radial: 1.0 mm (0.04 in)

Axial: 1.0 mm (0.04 in)

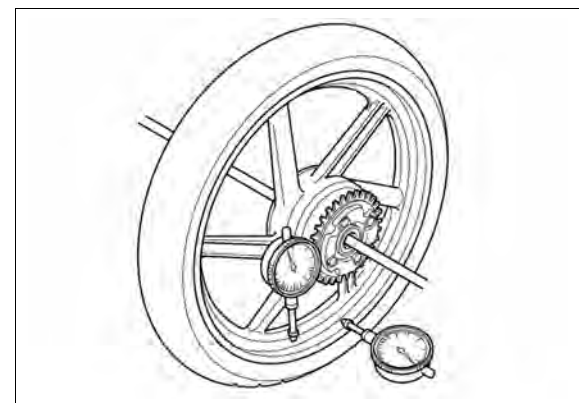

REAR WHEEL/BRAKE/SUSPENSION

DRIVEN SPROCKET

Check the condition of the driven sprocket teeth. Replace the sprocket if it is worn or damaged.

- If the driven sprocket requires replacement, inspect the drive chain and drive sprocket.
- Never install a new drive chain on a worn sprocket or a worn chain on new sprockets. Both chain and sprocket must be in good condition, or the replacement chain or sprocket will wear rapidly.

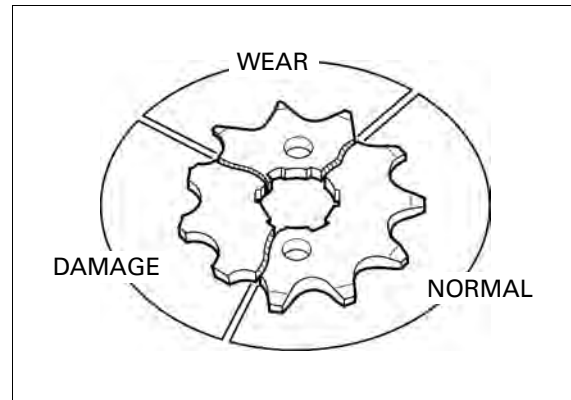

DISASSEMBLY

DRIVEN SPROCKET

Remove the driven flange assembly from the rear wheel.

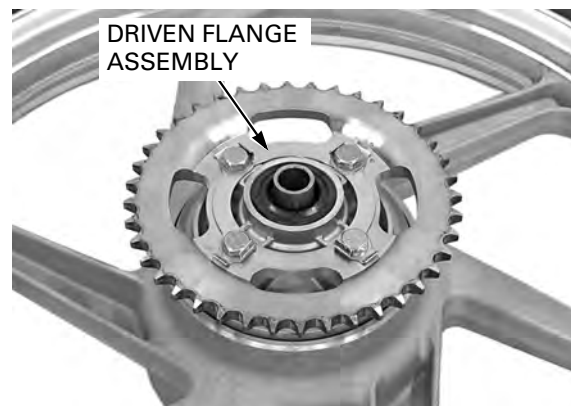

Remove the four damper rubbers and O-ring.

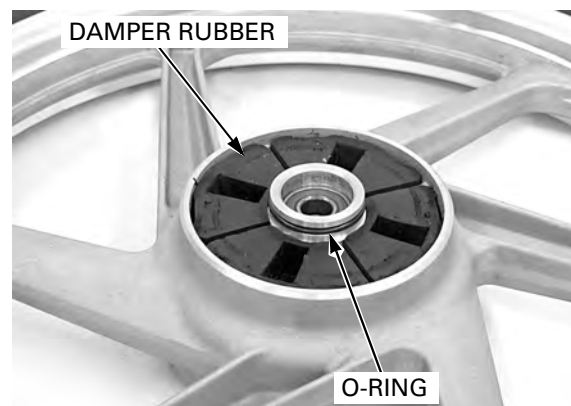

Bend down the lock plate tabs so that the bolts can be loosened.

Remove the following:

- Four bolts
- Lock plates
- Four nuts
- Driven sprocket
- Dust seal

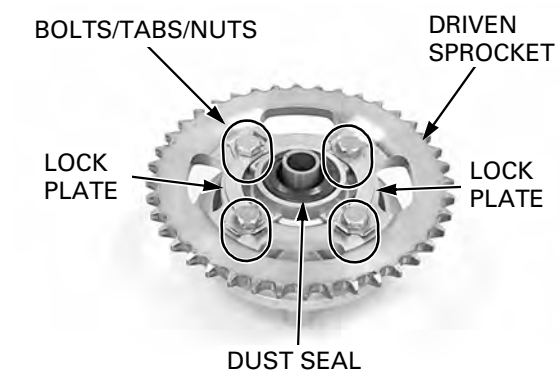

REAR WHEEL/BRAKE/SUSPENSION

DRIVEN FLANGE

Drive out the driven flange bearing and collar.

TOOLS:

Driver	07749-0010000
Attachment, 22 x 24 mm	07746-0010800
Pilot, 15 mm	07746-0040300

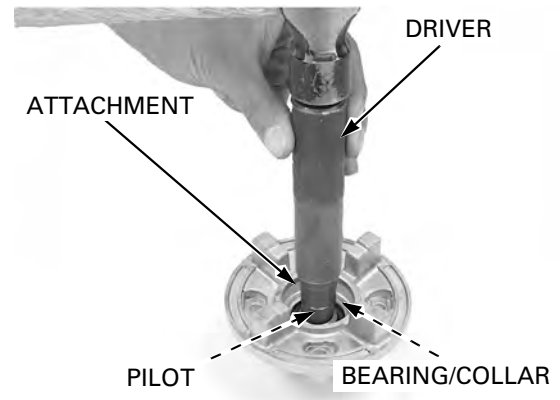

Pull out the collar from the driven flange bearing.

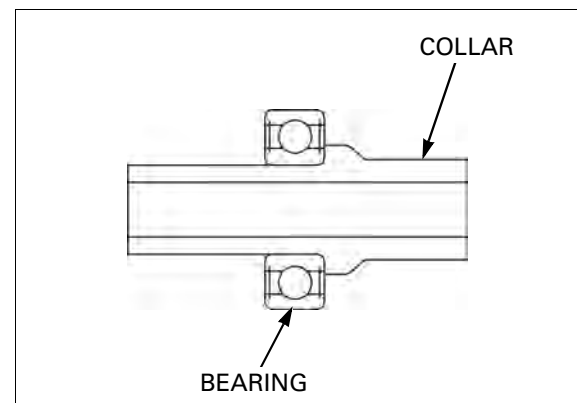

WHEEL BEARING

Install the remover head into the bearing.

From the opposite side of the wheel, install the bearing remover shaft and drive the bearing out of the wheel hub.

Remove the distance collar and drive out the other bearing.

TOOLS:

Bearing remover head, 15 mm	07746-0050400
Bearing remover shaft	07746-0050100



REAR WHEEL/BRAKE/SUSPENSION ASSEMBLY

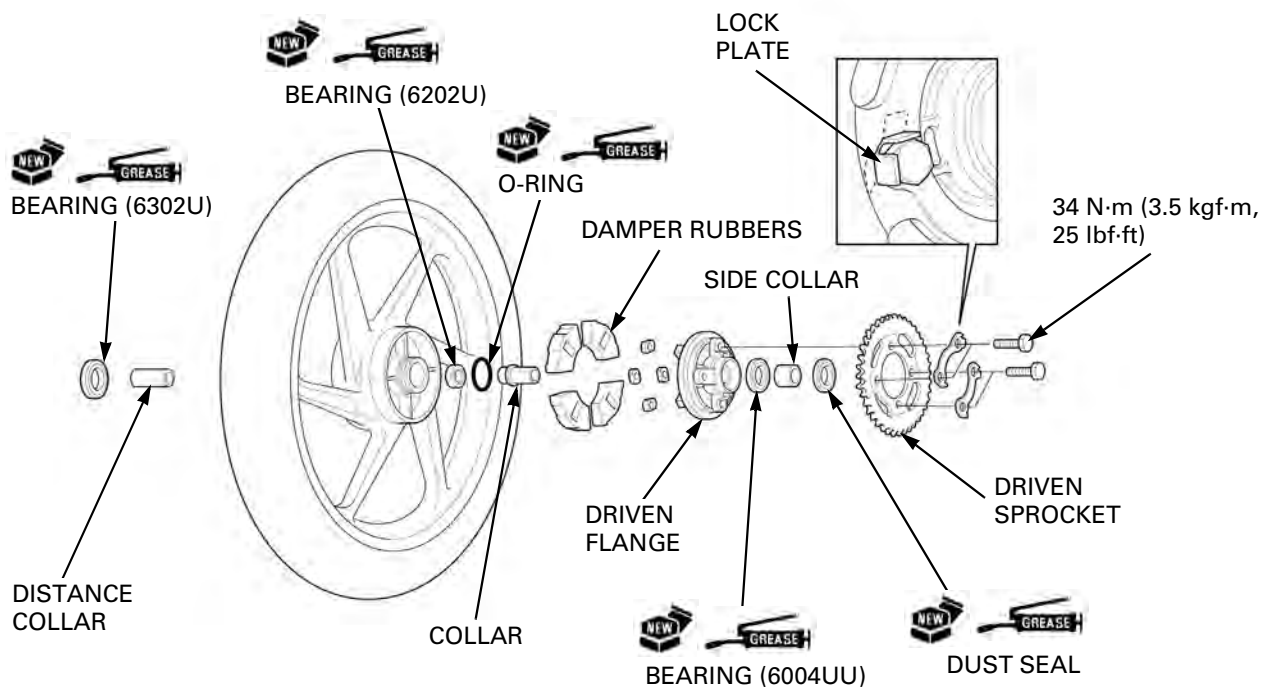

WHEEL BEARING

Pack new bearing cavities with grease.
Drive in a new right side (brake drum side) bearing squarely with the sealed side facing up until it is fully seated.

TOOLS:

Driver 07749-0010000
Attachment, 42 x 47 mm 07746-0010300
Pilot, 15 mm 07746-0040300

Install the distance collar.
Drive in a new left side bearing with the sealed side facing up.

TOOLS:

Driver 07749-0010000
Attachment, 32 x 35 mm 07746-0010100
Pilot, 15 mm 07746-0040300

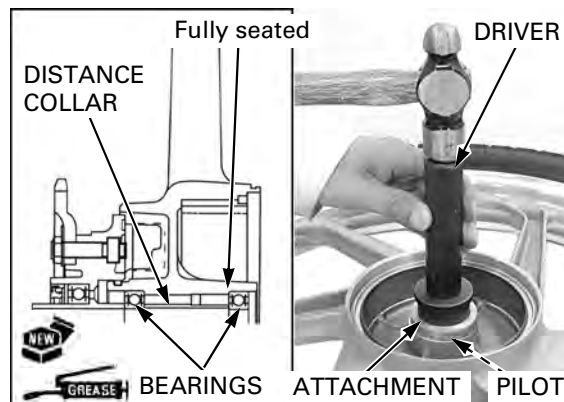

REAR WHEEL/BRAKE/SUSPENSION

DRIVEN FLANGE

Pack new bearing cavities with grease.

Drive in the driven flange bearing to the drive flange.

TOOLS:

Driver

07749-0010000

Attachment, 42 x 47 mm

07746-0010300

Pilot, 20 mm

07746-0040500

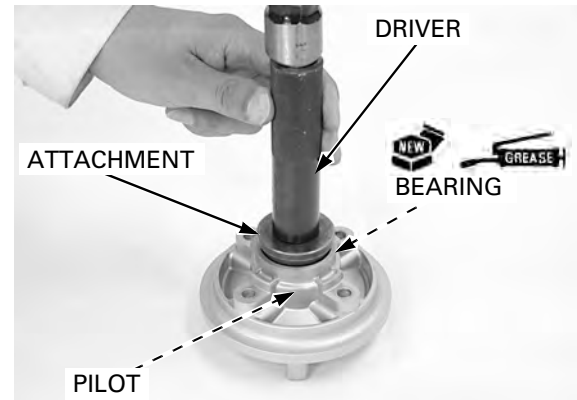

Install the collar to a new driven flange bearing.

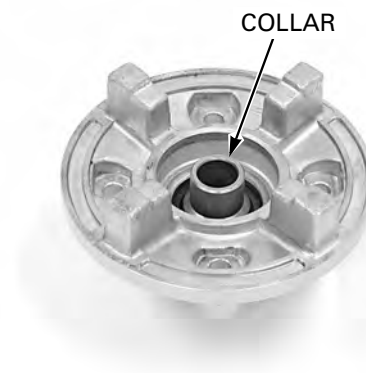

DRIVEN SPROCKET

Install the following:

- Driven sprocket
- Lock plates
- Four bolts
- Four nuts

Tighten the bolts to the specified torque.

TORQUE: 34 N·m (3.5 kgf·m, 25 lbf·ft)

Bend up the lock plate tabs against the bolts as shown so that the bolts cannot be loosened.

Apply grease to the lip of a new dust seal.
Install the dust seal.

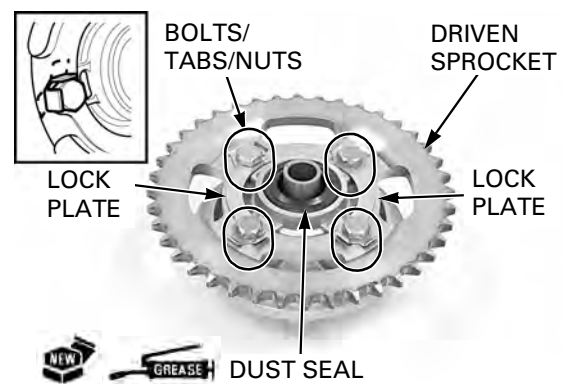

Apply grease to a new O-ring.

Install the damper rubbers and O-ring to the wheel hub.

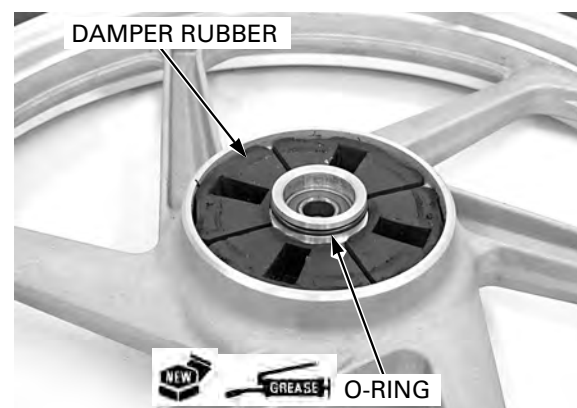

REAR WHEEL/BRAKE/SUSPENSION

Install the driven flange assembly to the rear wheel.

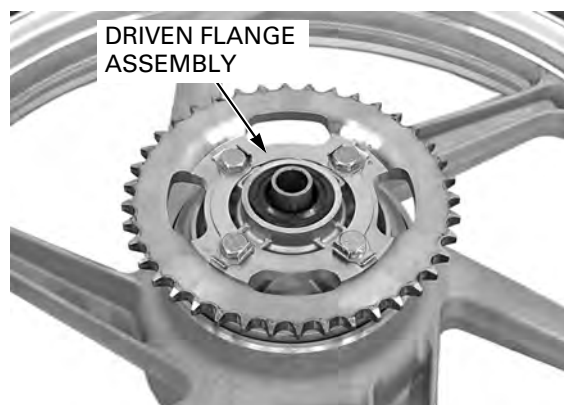

INSTALLATION

Install the side collar.

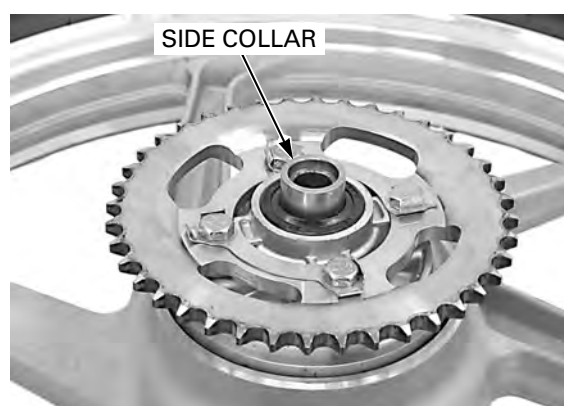

Do not get grease on the brake drum and shoe linings.

Install the brake panel into the wheel hub.

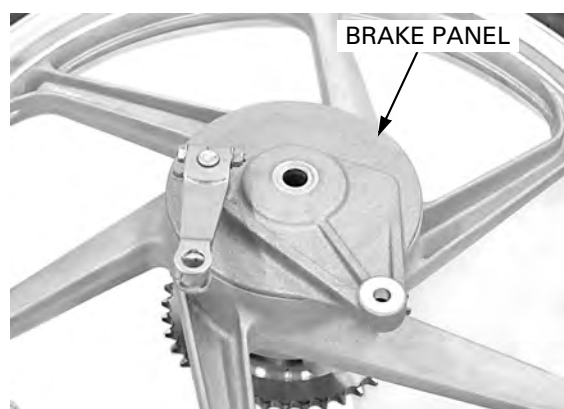

Place the rear wheel in the swingarm.

Install the drive chain over the driven sprocket.

Install both adjuster and adjuster plate to the swingarm.

Insert the axle from the right side through the swingarm, collar and wheel.

Adjust the drive chain slack (page 3-12).

Tighten the axle nut to the specified torque.

TORQUE: 59 N·m (6.0 kgf·m, 44 lbf·ft)

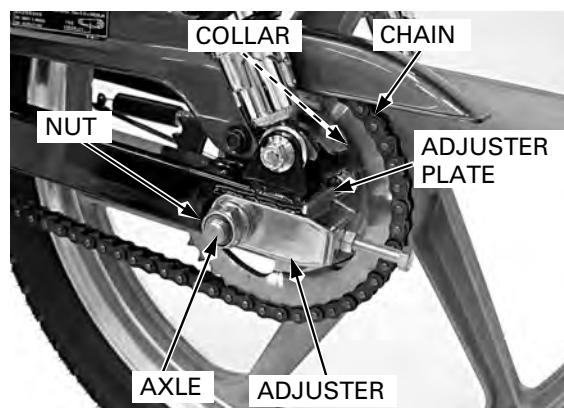

REAR WHEEL/BRAKE/SUSPENSION

Install the following:

- Brake panel stopper arm
- Joint bolt
- Washer

Install and tighten the nut to the specified torque.

TORQUE: 22 N·m (2.2 kgf·m, 16 lbf·ft)

Install the new cotter pin.

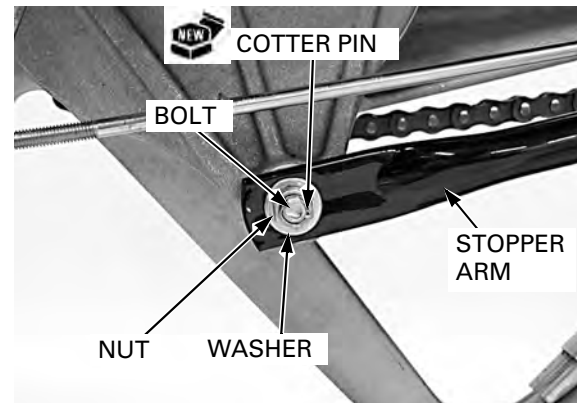

Install the spring onto the brake rod and the joint pin into the brake arm.
Connect the brake rod to the brake arm with the adjusting nut.

Adjust the brake pedal free play (page 3-17).

Inspect the rear brake light operation.

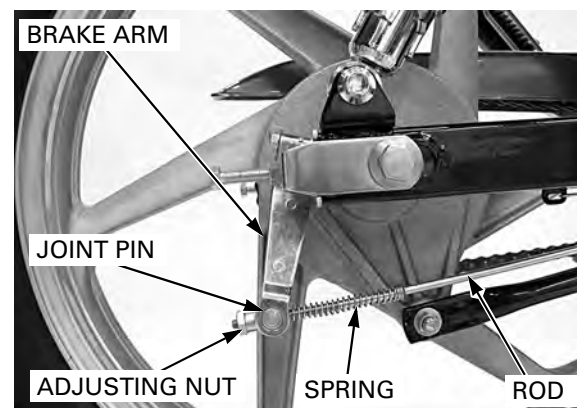

REAR DRUM BRAKE

INSPECTION

Remove the rear wheel (page 13-6).

Measure the rear brake drum I.D.

SERVICE LIMIT: 131.0 mm (5.16 in)

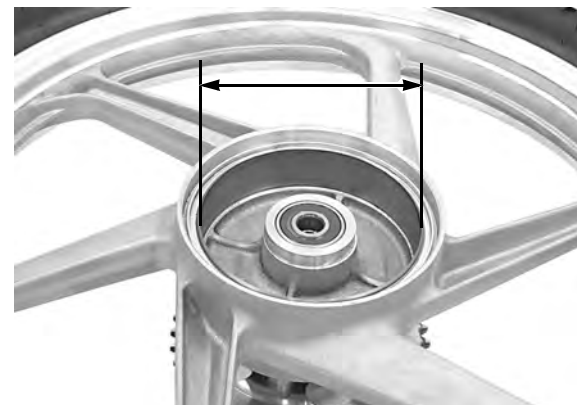

DISASSEMBLY

Remove the brake panel (page 13-6).

*Always replace the
brake shoes in
pairs.*

Expand the brake shoes and remove them from the brake panel.

Remove the shoe springs from the brake shoes.

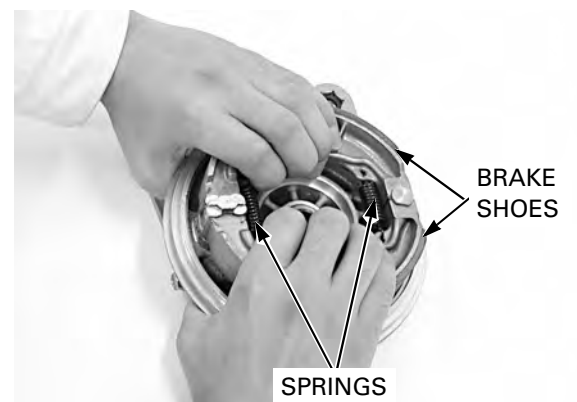

REAR WHEEL/BRAKE/SUSPENSION

Remove the following:

- Nut and bolt
- Brake arm
- Wear indicator
- Brake cam

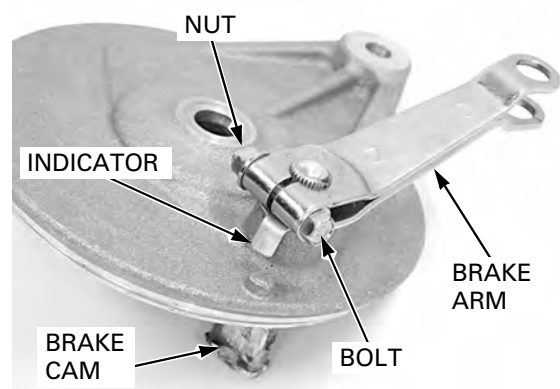

Remove the felt seal.

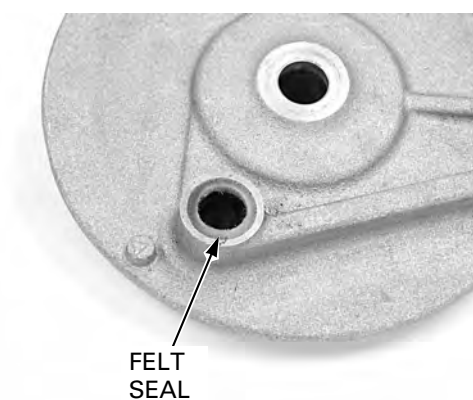

ASSEMBLY

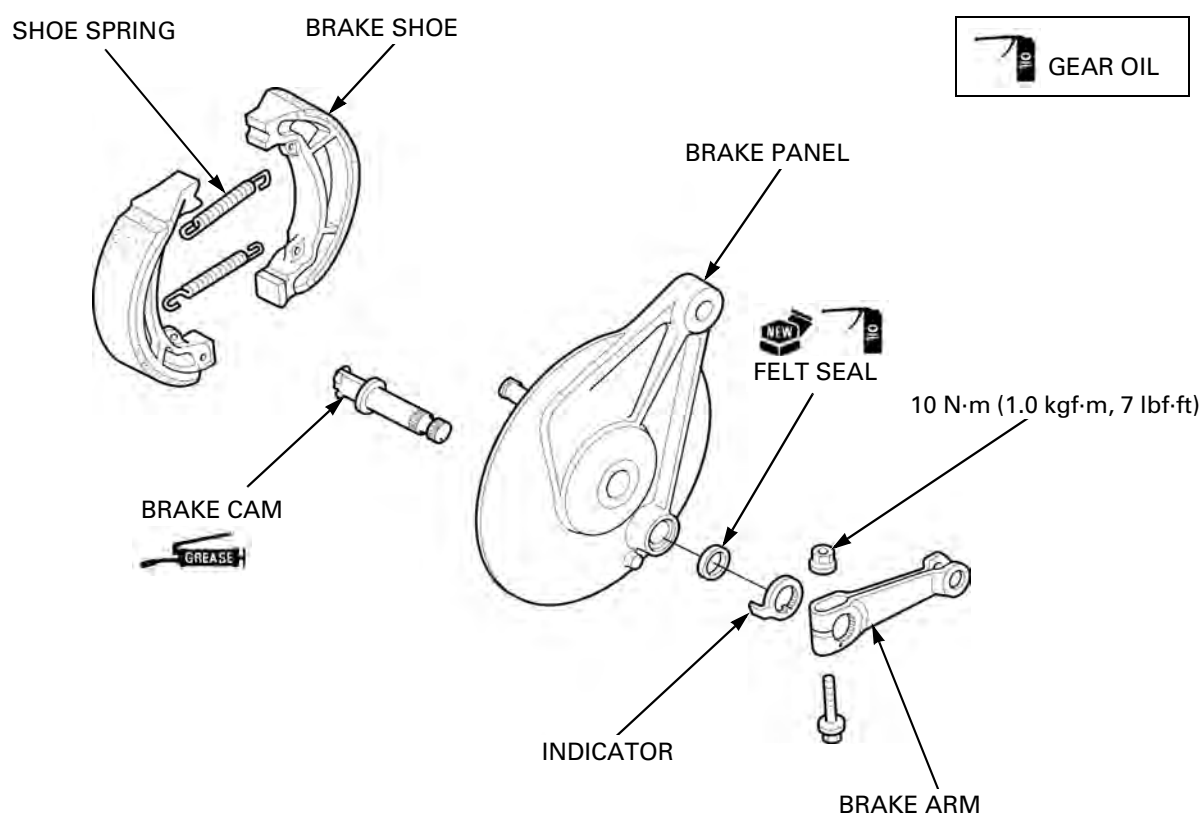

REAR WHEEL/BRAKE/SUSPENSION

Apply gear oil to a new felt seal and install it.

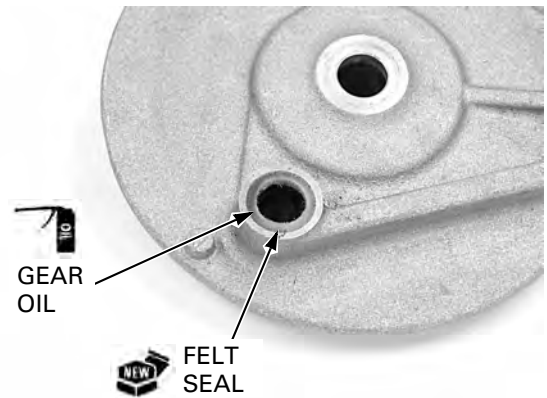

Apply grease to the sliding surface of the brake cam.
Install the brake cam to the brake panel.

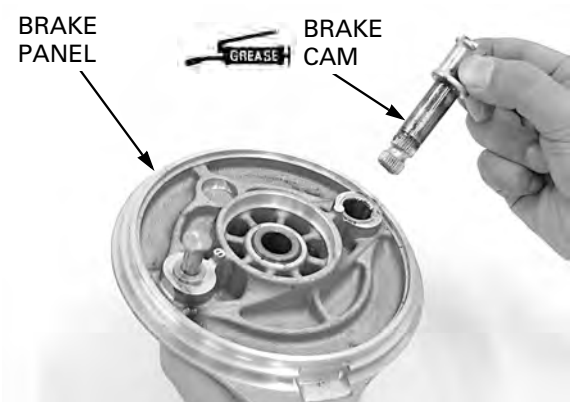

Install the wear indicator, aligning the wide tooth with the wide groove in the brake cam.

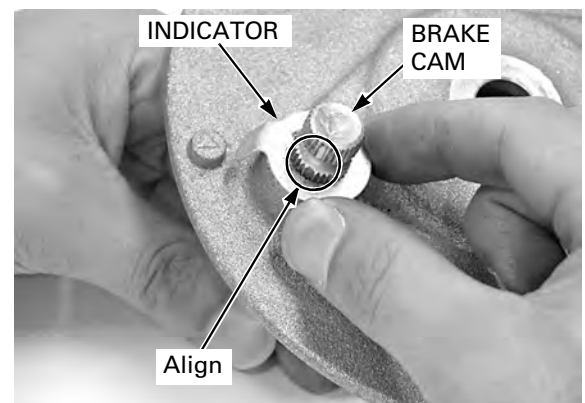

Install the brake arm, aligning the punch marks of the brake cam and the brake arm.

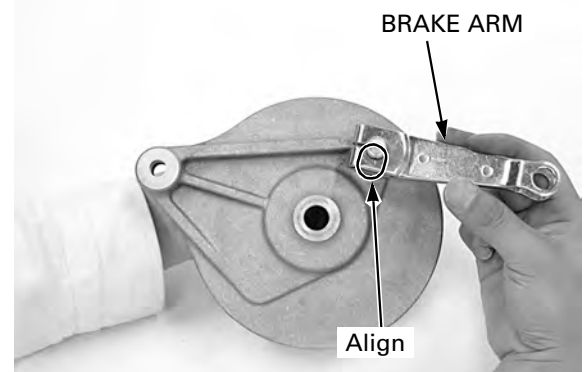

REAR WHEEL/BRAKE/SUSPENSION

Install the bolt and tighten the nut to the specified torque.

TORQUE: 10 N·m (1.0 kgf·m, 7 lbf·ft)

Apply grease to the anchor pin and brake cam sliding surfaces.

Assemble the brake shoes and springs as shown. Install the shoe assembly onto the brake panel.

Wipe any excess grease from the brake cam and anchor pin.

Install the brake panel (page 13-12).

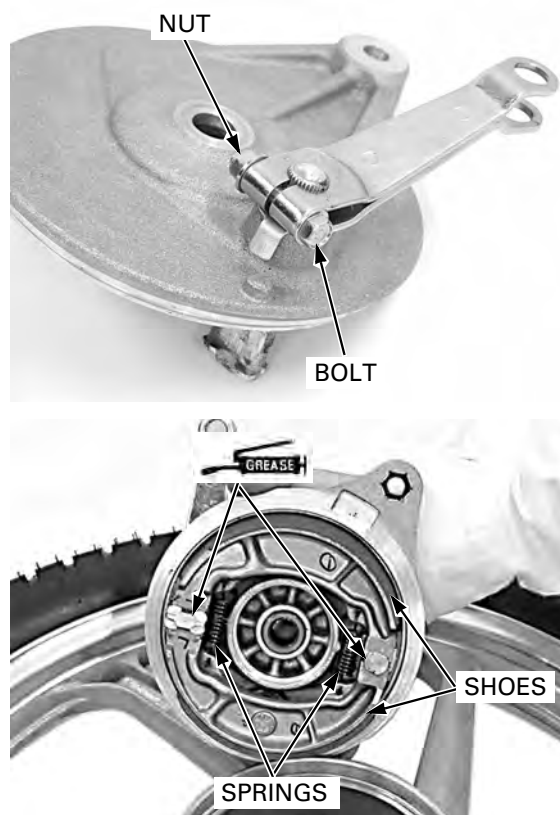

BRAKE PEDAL/CENTER STAND

REMOVAL

Raise and support the motorcycle using safety stand or a box.

Do not remove the swingarm pivot.

Remove the following:

- Exhaust pipe/muffler (page 2-8)
- Rear wheel (page 13-6)
- Bolt and heat protector
- Right pillion step mounting bolt
- Swingarm pivot nut
- Right pillion step bracket
- Washer

Remove the center stand spring and unhook the rear brake light switch spring.

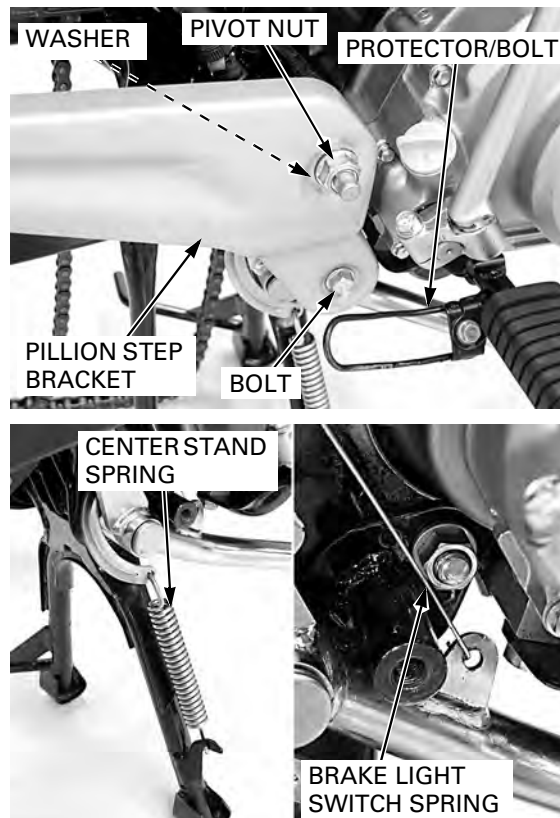

REAR WHEEL/BRAKE/SUSPENSION

Remove the rear brake return spring.

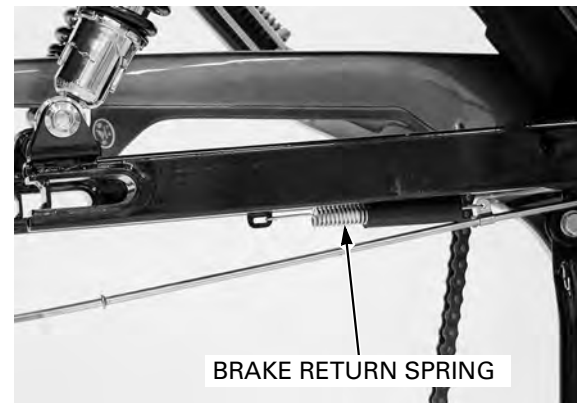

Remove the left pillion step bracket mounting bolt and rotate the left pillion step bracket so that the center stand pivot is accessible.

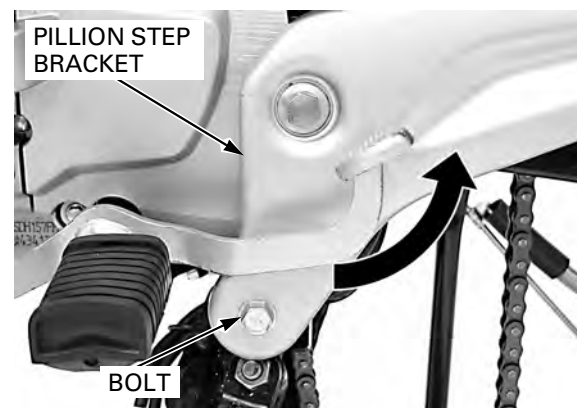

Remove the cotter pin and washer from the center stand pivot.

Pull out the pivot and remove the center stand and rear brake pedal.

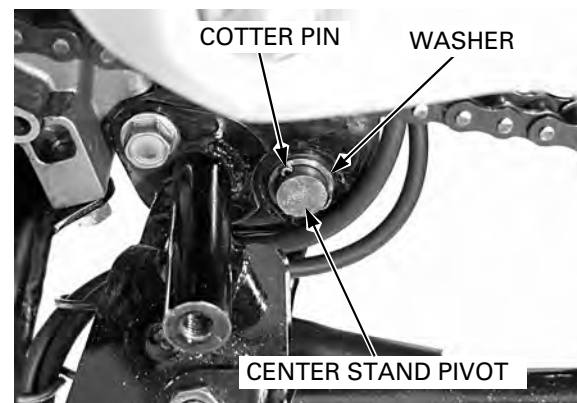

Remove the following:

- Cotter pin
- Washer
- Brake rod

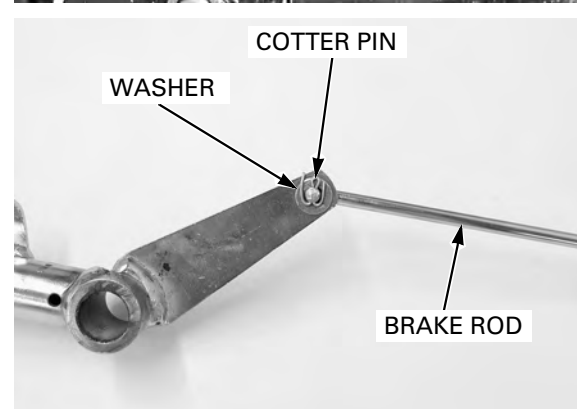

REAR WHEEL/BRAKE/SUSPENSION

INSTALLATION

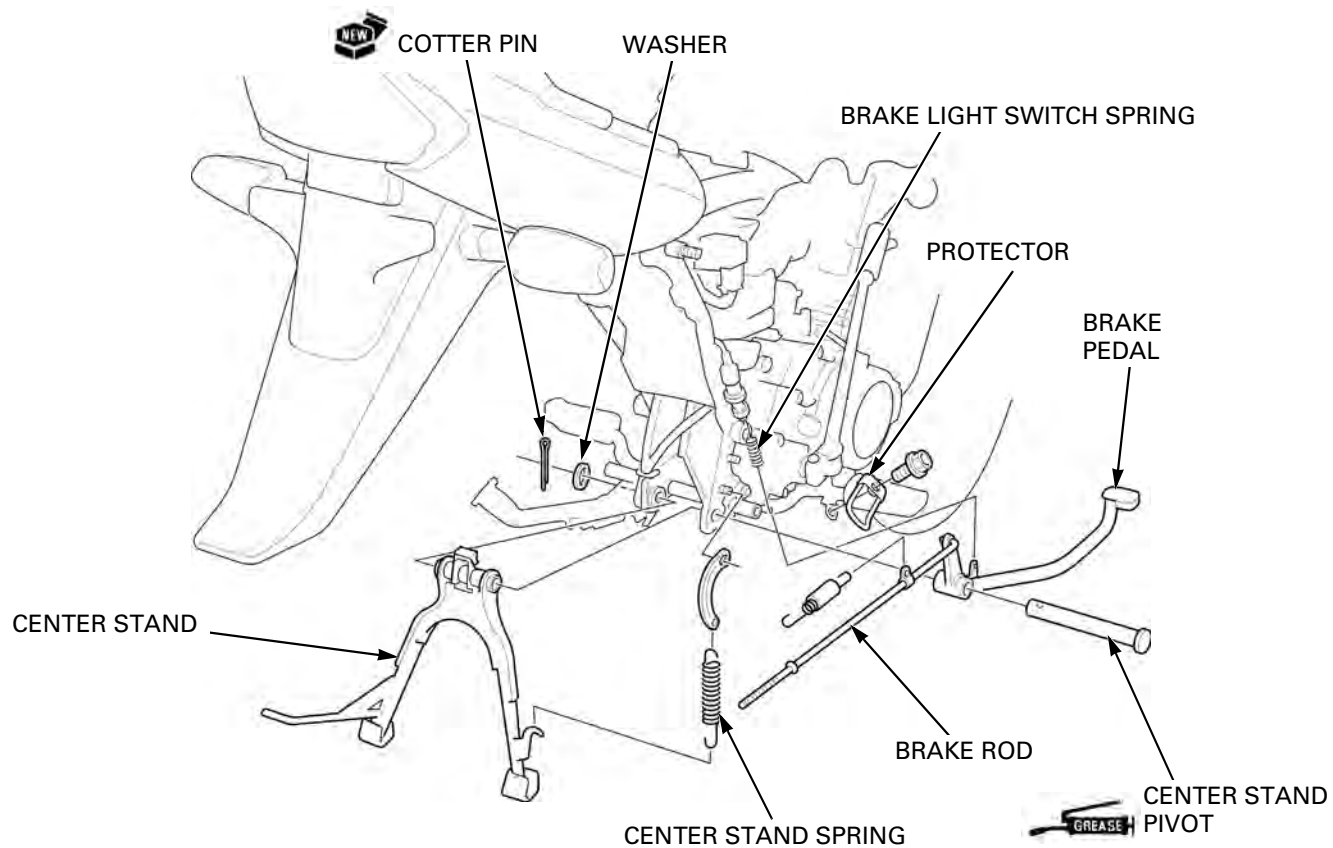

Connect the brake rod to the pedal with the washer and a new cotter pin.

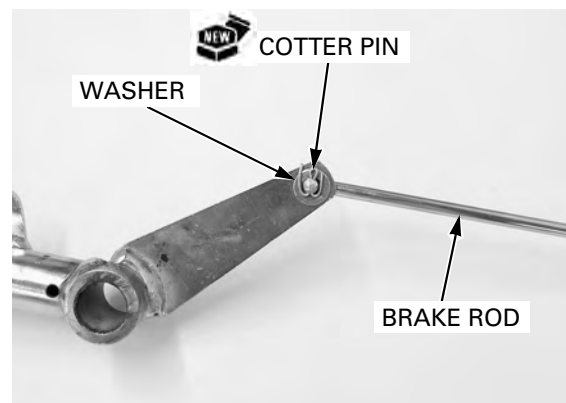

Apply grease to the center stand pivot.

Install the following:

- Center stand
- Brake pedal
- Center stand pivot
- Washer

Install a new cotter pin.

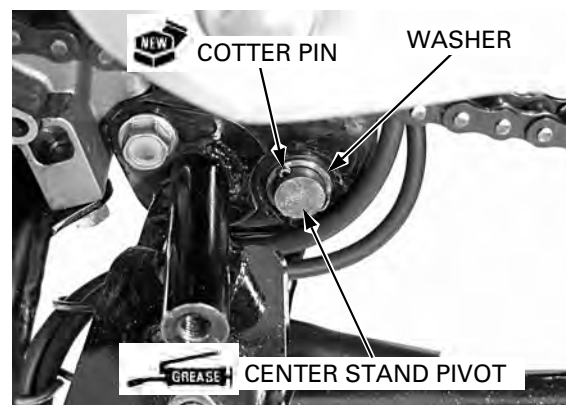

REAR WHEEL/BRAKE/SUSPENSION

Rotate the left pillion step bracket back to its original position.

Install the left pillion step bracket mounting bolt.

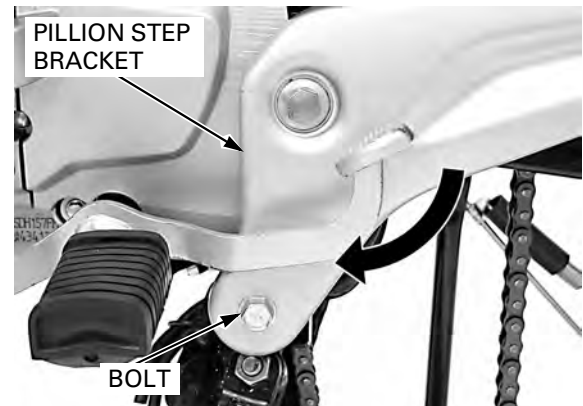

Install the rear brake return spring.



Install the center stand spring and hook the rear brake light switch spring to rear brake pedal.

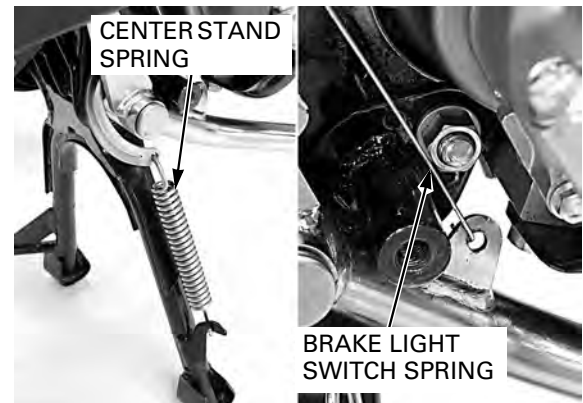

Set the washer to the swingarm pivot and install the right pillion step bracket and right pillion step bracket mounting bolt.

Install and tighten the swingarm pivot nut to the specified torque.

TORQUE: 59 N·m (6.0 kgf·m, 44 lbf·ft)

Tighten the right and left pillion step bracket bolts to the specified torque.

TORQUE: 45 N·m (4.6 kgf·m, 33 lbf·ft)

Install the heat protector and tighten the bolt.

Install the following:

- Rear wheel (page 13-12)
- Exhaust pipe/muffler (page 2-9)

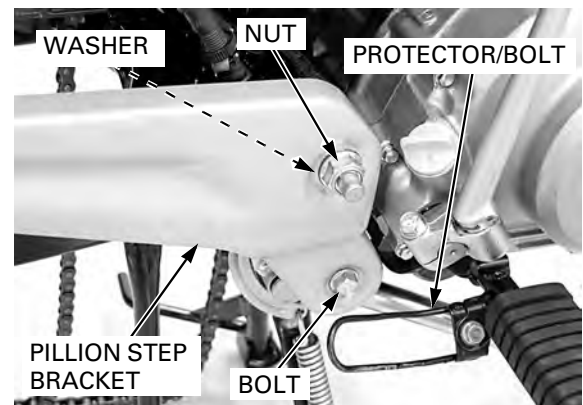

REAR WHEEL/BRAKE/SUSPENSION

SHOCK ABSORBER

REMOVAL

- Remove the exhaust pipe/muffler (page 2-8).
- Place the motorcycle on its center stand.
- Remove the upper mounting nut and washer.
- Remove the lower mounting bolt and shock absorber.

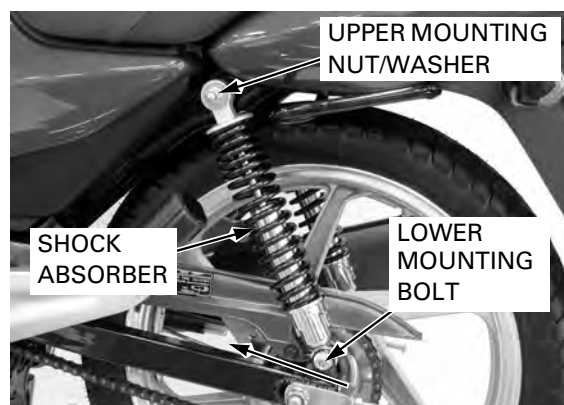

INSPECTION

Replace the shock absorber as an assembly.

Visually inspect the shock absorber for wear or damage.

Check the following:

- Damper rod for bending or damage
- Damper unit for leakage or other damage
- Bushing for wear or damage

Check for smooth damper operation.

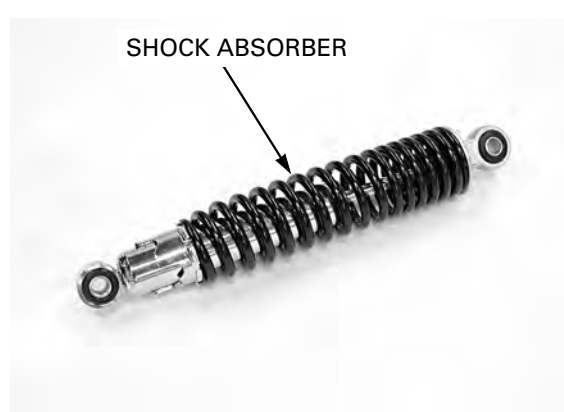

INSTALLATION

Install the shock absorber and lower mounting bolt.

Install the washer and upper mounting nut.

Tighten the upper mounting nut and lower mounting bolt to the specified torque.

TORQUE:

Shock absorber upper mounting nut: 34 N·m (3.5 kgf·m, 25 lbf·ft)

Shock absorber lower mounting bolt: 34 N·m (3.5 kgf·m, 25 lbf·ft)

Install the exhaust pipe/muffler (page 2-9).

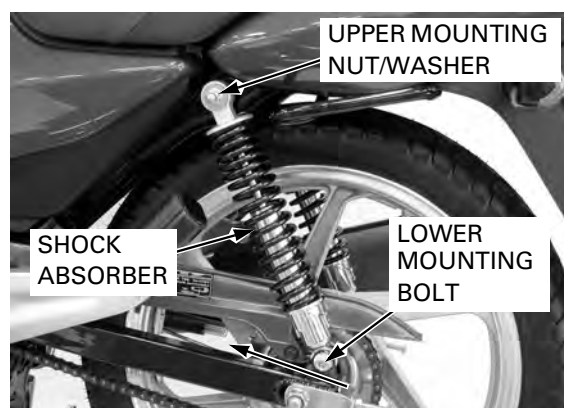

SWINGARM

REMOVAL

Remove the following:

- Exhaust pipe/muffler (page 2-8)
- Rear wheel (page 13-6)
- Swingarm pivot nut
- Right pillion step bracket mounting bolt
- Right pillion step bracket
- Washer

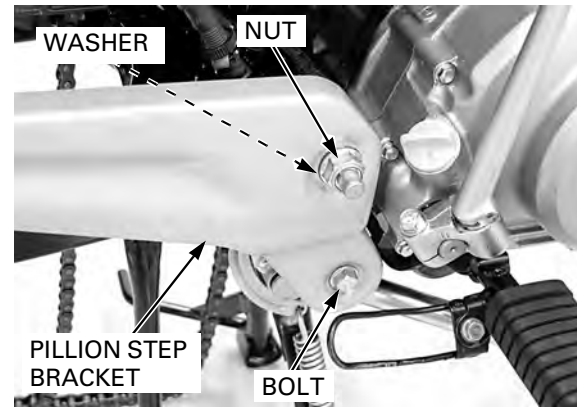

Remove the rear brake return spring.

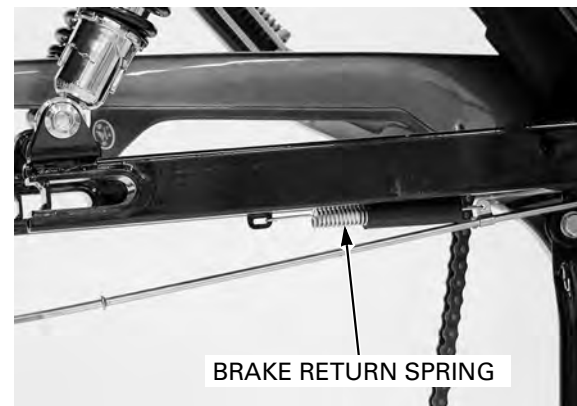

Remove the chain cover mounting bolts and washers.



Remove the shock absorber lower mounting bolts.

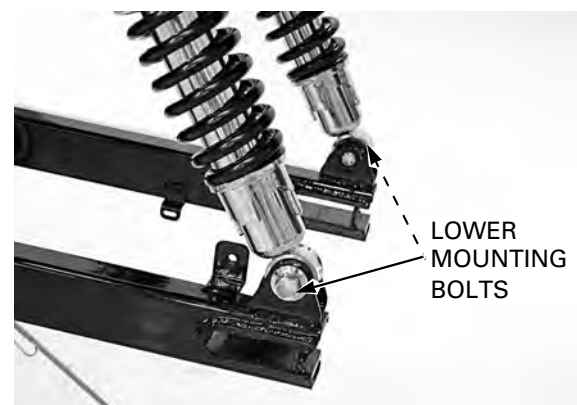

REAR WHEEL/BRAKE/SUSPENSION

Remove the following:

- Left pillion step bracket mounting bolt
- Swingarm pivot
- Left pillion step bracket
- Washer
- Swingarm

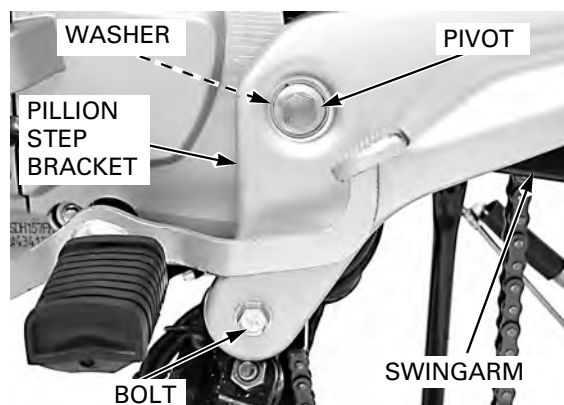

DISASSEMBLY

Remove the following:

- Cotter pin
- Nut
- Washer
- Joint bolt
- Brake panel stopper arm

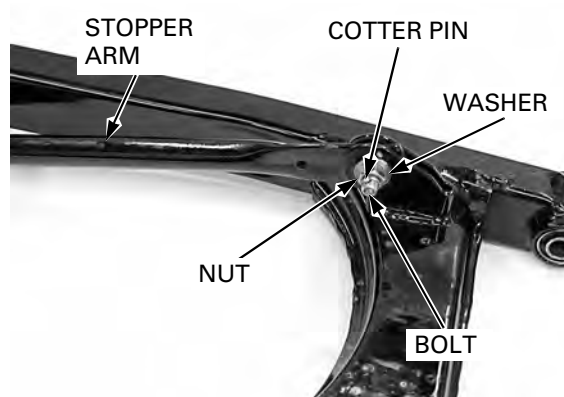

Remove the chain slider.



INSPECTION

Check the swingarm for cracks or other damage.

Check the pivot bushing for wear, deterioration or damage.

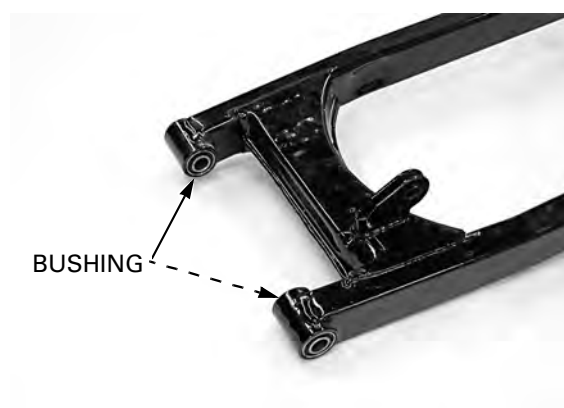

ASSEMBLY

Install the chain slider aligning the tab and the swingarm groove.

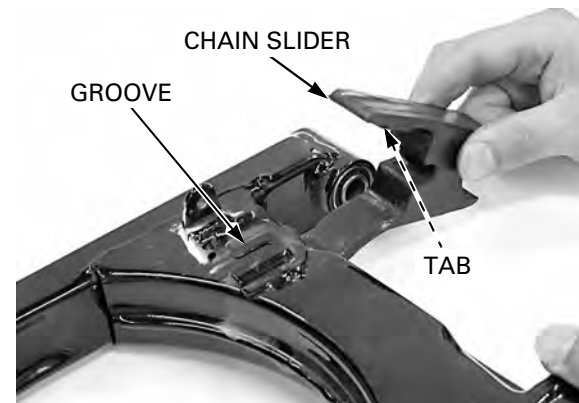

Install the following:

- Brake panel stopper arm
- Joint bolt
- Washer

Install and tighten the nut to the specified torque.

TORQUE: 22 N·m (2.2 kgf·m, 16 lbf·ft)

Install the new cotter pin.

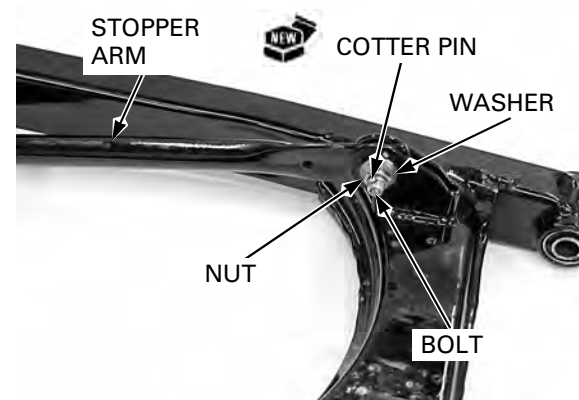

INSTALLATION

Install the following:

- Swingarm
- Washer
- Left pillion step bracket
- Swingarm pivot
- Left pillion step bracket mounting bolt

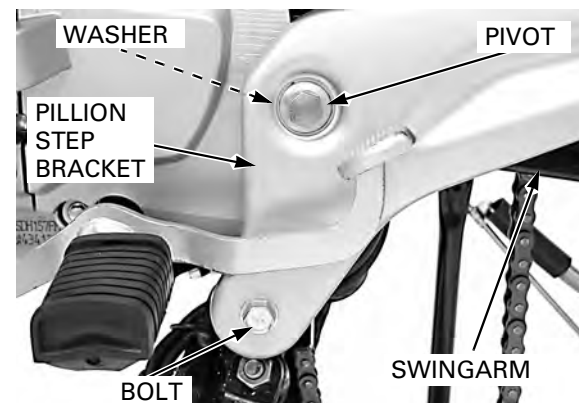

Install and tighten the shock absorber lower mounting bolts to the specified torque.

TORQUE: 34 N·m (3.5 kgf·m, 25 lbf·ft)

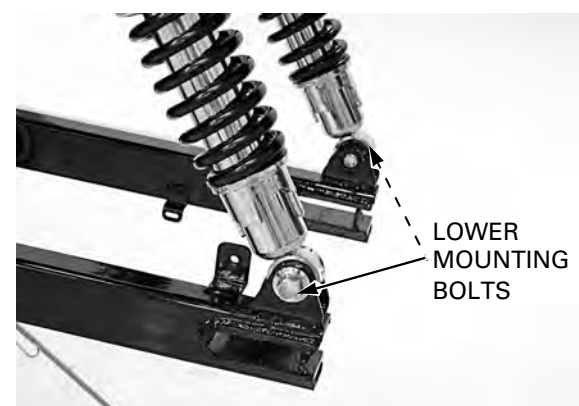

REAR WHEEL/BRAKE/SUSPENSION

Install the chain cover mounting bolts and washers.

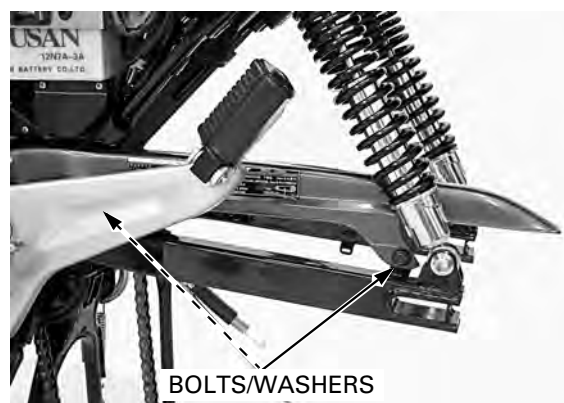

Install the rear brake return spring.



Set the washer to the swingarm pivot and install the right pillion step bracket and the mounting bolt.

Install and tighten the swingarm pivot nut to the specified torque.

TORQUE: 59 N·m (6.0 kgf·m, 44 lbf·ft)

Tighten the right and left pillion step bracket bolts to the specified torque.

TORQUE: 45 N·m (4.6 kgf·m, 33 lbf·ft)

Install the following:

- Rear wheel (page 13-12)
- Exhaust pipe/muffler (page 2-9)

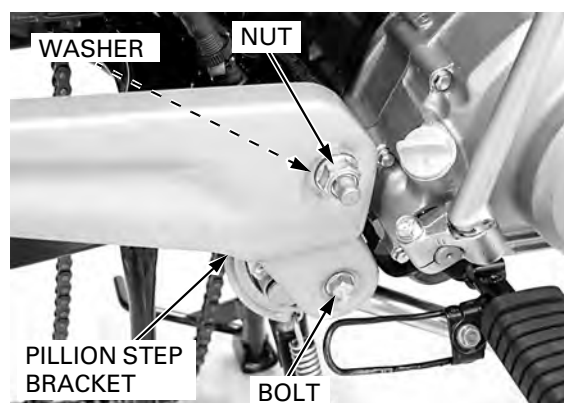

14. HYDRAULIC BRAKE

SYSTEM COMPONENTS	14-2	BRAKE PAD/DISC.....	14-7
SERVICE INFORMATION	14-3	MASTER CYLINDER.....	14-10
TROUBLESHOOTING	14-4	BRAKE CALIPER	14-15
BRAKE FLUID REPLACEMENT/ AIR BLEEDING	14-5		

**HYDRAULIC BRAKE
SYSTEM COMPONENTS**

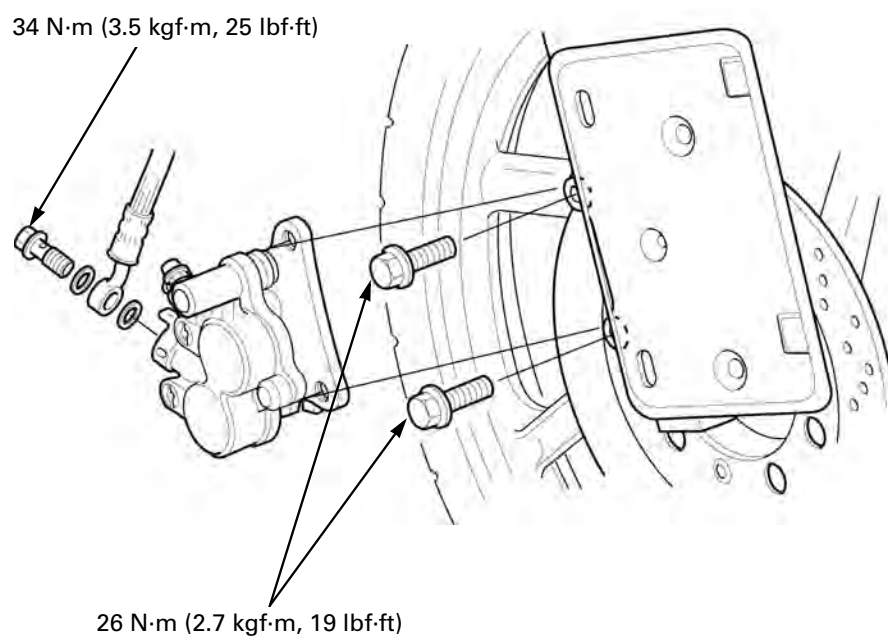
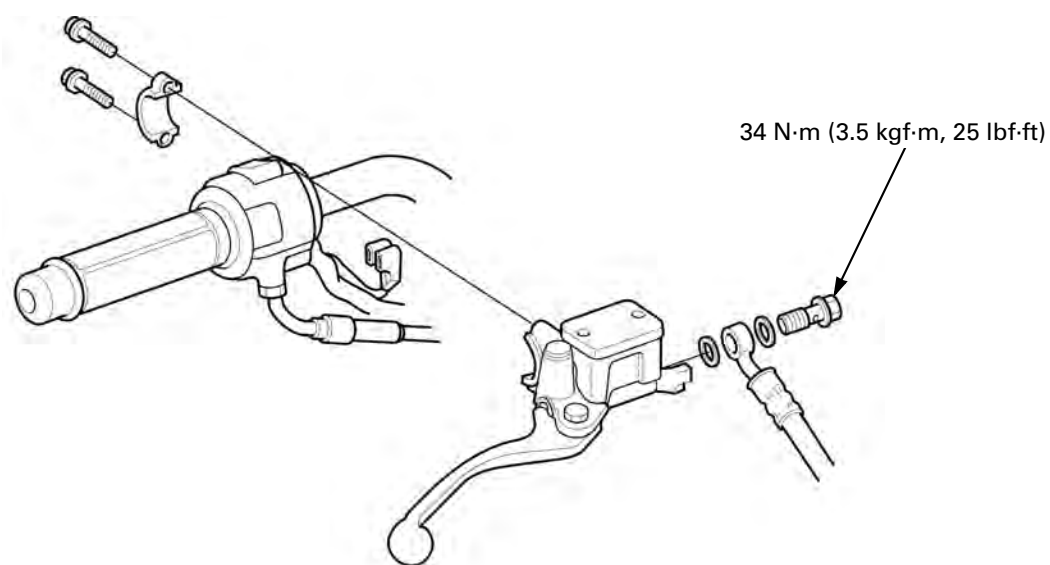

SERVICE INFORMATION

GENERAL

⚠ CAUTION

Frequent inhalation of brake pad dust, regardless of material composition, could be hazardous to your health.

- Avoid breathing dust particles.
- Never use an air hose or brush to clean brake assemblies. Use an OSHA-approved vacuum cleaner.

NOTICE

Spilling brake fluid will severely damage instrument lenses and painted surface. It is also harmful to some rubber parts. Be careful whenever you remove the reservoir cap; make sure the front reservoir is horizontal first.

- This section covers the services for disc brake type only.
- A contaminated brake disc or pad reduces stopping power. Discard contaminated pads and clean a contaminated disc with a high quality brake degreasing agent.
- Check the brake system by applying the brake lever after the air bleeding.
- Never allow contaminants (dirt, water, etc.) to get into an open reservoir.
- Once the hydraulic system has been opened, or if the brake feels spongy, the system must be bled.
- Always use fresh DOT 3 or DOT 4 brake fluid from a sealed container when servicing the system. Do not mix different types of fluid, they may not be compatible.
- Always check brake operation before riding the motorcycle.

SPECIFICATION

Unit: mm (in)

ITEM	STANDARD	SERVICE LIMIT
Recommended brake fluid (Type II, IV)	DOT 3 or DOT 4	–
Brake disc thickness	3.8 – 4.2 (0.15 – 0.17)	3.5 (0.14)
Brake disc runout	–	0.25 (0.010)
Master cylinder I.D.	12.700 – 12.743 (0.5000 – 0.5017)	12.755 (0.5022)
Master piston O.D.	12.657 – 12.684 (0.4983 – 0.4994)	12.645 (0.4978)
Caliper cylinder I.D.	25.400 – 25.450 (1.0000 – 1.0020)	25.460 (1.0024)
Caliper piston O.D.	25.318 – 25.368 (0.9968 – 0.9987)	25.31 (0.996)

TORQUE VALUES

Caliper bleed valve	5.9 N·m (0.6 kgf·m, 4.4 lbf·ft)	
Master cylinder reservoir cap screw	1.5 N·m (0.2 kgf·m, 1.1 lbf·ft)	
Pad pin	17 N·m (1.7 kgf·m, 13 lbf·ft)	
Pad pin plug	2.5 N·m (0.3 kgf·m, 1.8 lbf·ft)	
Brake caliper mounting bolt	26 N·m (2.7 kgf·m, 19 lbf·ft)	ALOC bolt; replace with a new one.
Front brake light switch screw	1.2 N·m (0.1 kgf·m, 0.9 lbf·ft)	
Brake lever pivot bolt	1.0 N·m (0.1 kgf·m, 0.7 lbf·ft)	
Brake lever pivot nut	5.9 N·m (0.6 kgf·m, 4.4 lbf·ft)	
Brake hose oil bolt	34 N·m (3.5 kgf·m, 25 lbf·ft)	

TOOL

Snap ring pliers
07914-SA50001

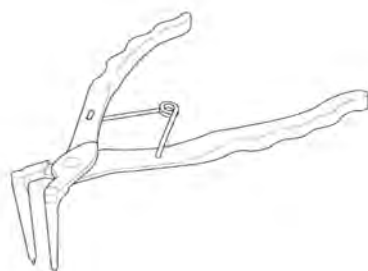

HYDRAULIC BRAKE

TROUBLESHOOTING

Brake lever soft or spongy

- Air in hydraulic system
- Leaking hydraulic system
- Contaminated brake pad/disc
- Worn caliper piston seal
- Worn master cylinder piston cups
- Worn brake pad/disc
- Contaminated caliper
- Contaminated master cylinder
- Caliper not sliding properly
- Low brake fluid level
- Clogged fluid passage
- Warped/deformed brake disc
- Sticking/worn caliper piston
- Sticking/worn master cylinder piston
- Bent brake lever

Brake lever hard

- Clogged/restricted brake system
- Sticking/worn caliper piston
- Caliper not sliding properly
- Worn caliper piston seal
- Sticking/worn master cylinder piston
- Bent brake lever

Brake drags

- Contaminated brake pad/disc
- Misaligned wheel
- Badly worn brake pad/disc
- Warped/deformed brake disc
- Caliper not sliding properly
- Clogged/restricted fluid passage
- Sticking caliper piston

BRAKE FLUID REPLACEMENT/AIR BLEEDING

BRAKE FLUID DRAINING

Turn the handlebar until the reservoir is parallel to the ground before removing the reservoir cap.

Remove the screws, reservoir cap, diaphragm plate and diaphragm.

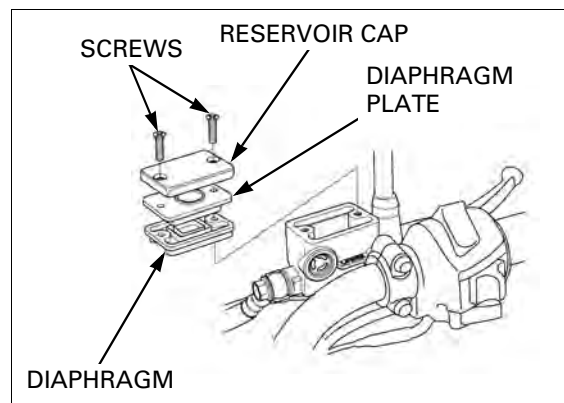

Connect a bleed hose to the caliper bleed valve.

Loosen the bleed valve and pump the brake lever until no more fluid flows out of the bleed valve.

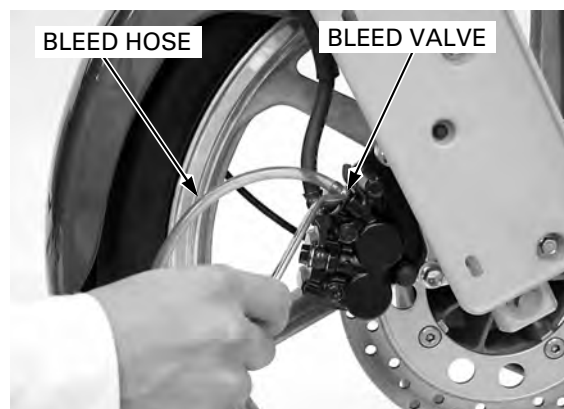

BRAKE FLUID FILLING/AIR BLEEDING

Do not mix different types of fluid. They are not compatible.

Fill the master cylinder reservoir with DOT 3 or DOT 4 brake fluid from a sealed container.

- Check the fluid level often while bleeding the brake to prevent air from being pumped into the system.

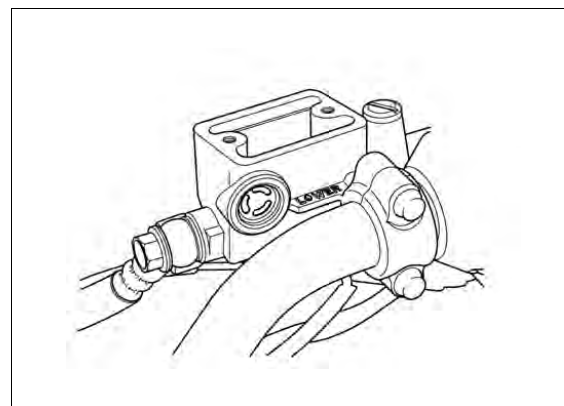

- When using a brake bleeding tool, follow the manufacturer's operating instructions.

If air enters the bleeder from around the bleed valve threads, seal the threads with teflon tape.

Connect a commercially available brake bleeder to the bleed valve. Operate the brake bleeder and loosen the bleed valve.

Perform the bleeding procedure until the system is completely flushed/bled. Close the bleed valve and operate the brake lever. If it still feels spongy, bleed the system again.

After bleeding the system completely, tighten the bleed valve to the specified torque.

TORQUE: 5.9 N·m (0.6 kgf·m, 4.4 lbf·ft)

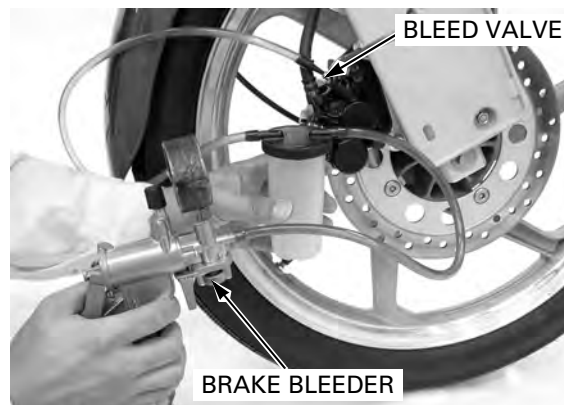

HYDRAULIC BRAKE

If the brake bleeder is not available, perform the following procedure.

Pump up the system pressure with the brake lever until the lever resistance is felt.

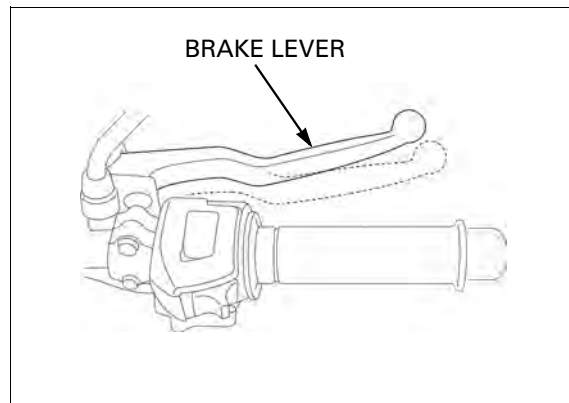

Connect a bleed hose to the bleed valve and bleed the system as follows:

Do not release the brake lever until the bleed valve is closed.

1. Squeeze the brake lever all the way and loosen the bleed valve 1/2 of a turn. Wait several seconds and then close the bleed valve.
2. Release the brake lever slowly and wait several seconds after it reaches the end of its travel.
3. Repeat the steps 1 and 2 until there are no air bubbles in the bleed hose.

After bleeding the system completely, tighten the bleed valve to the specified torque.

TORQUE: 5.9 N·m (0.6 kgf·m, 4.4 lbf·ft)

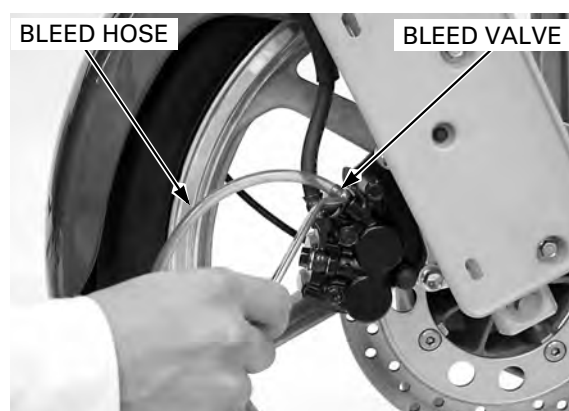

Do not mix different types of fluid. They are not compatible.

Fill the reservoir to the casting ledge with DOT 3 or DOT 4 brake fluid from a sealed container.

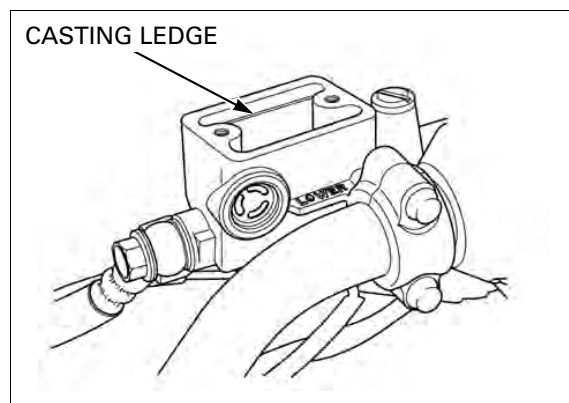

Install the diaphragm, diaphragm plate and reservoir cap, then tighten the screws to the specified torque.

TORQUE: 1.5 N·m (0.2 kgf·m, 1.1 lbf·ft)

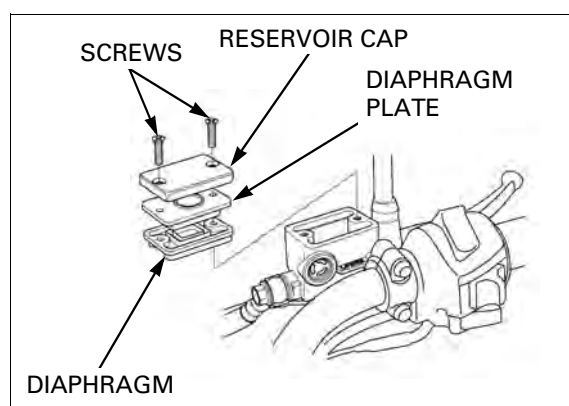

BRAKE PAD/DISC

BRAKE PAD REPLACEMENT

Check the fluid level in the master cylinder reservoir as this operation causes the fluid level to rise.

Remove the license plate holder (page 2-8).

Push the caliper pistons all the way in by pushing the caliper body inward to allow installation of new brake pads.



Remove the pad pin plug.

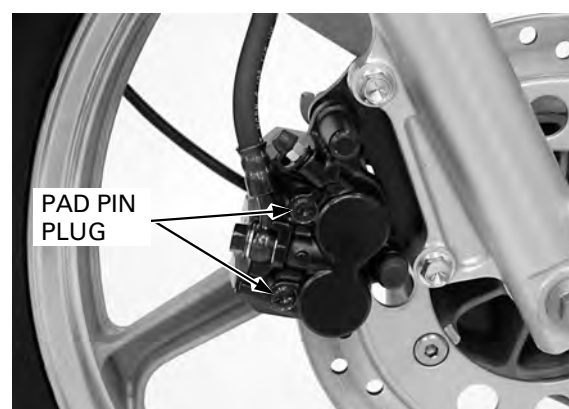

Loosen the pad pins.

Remove the caliper mounting bolts and brake caliper.

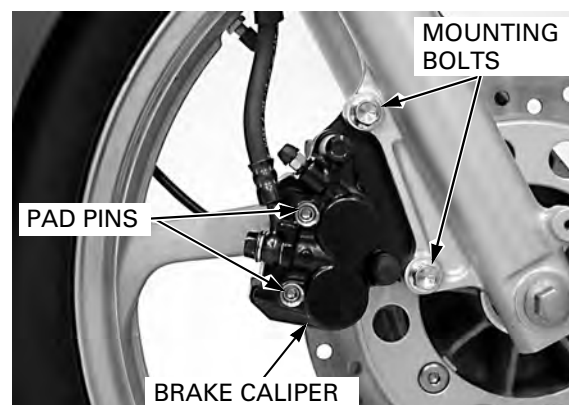

Remove the pad pins.

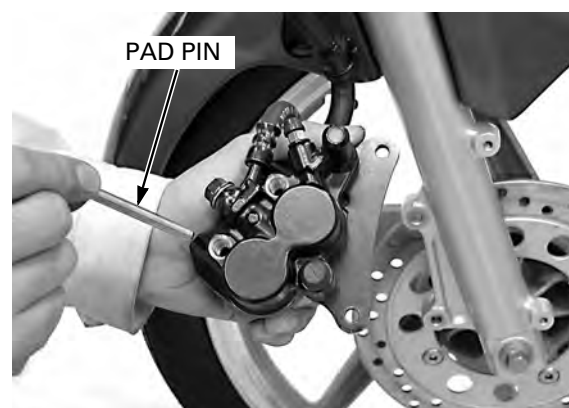

HYDRAULIC BRAKE

Remove the brake pads.



Make sure the pad spring is installed in position.



*Always replace the
brake pads in pairs.*

Install the new brake pads.



Install the pad pin by pushing the pads against the pad spring to align the pad pin holes of the pads and caliper.



HYDRAULIC BRAKE

Install the brake caliper and new mounting bolts. Tighten the brake caliper mounting bolts to the specified torque.

TORQUE: 26 N·m (2.7 kgf·m, 19 lbf·ft)

Tighten the pad pins to the specified torque.

TORQUE: 17 N·m (1.7 kgf·m, 13 lbf·ft)

Operate the brake lever to seat the caliper pistons against the pads.

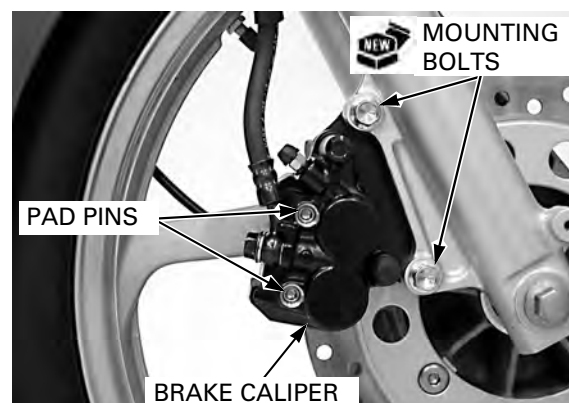

Install and tighten the pad pin plugs to the specified torque.

TORQUE: 2.5 N·m (0.3 kgf·m, 1.8 lbf·ft)

Install the license plate holder (page 2-8).

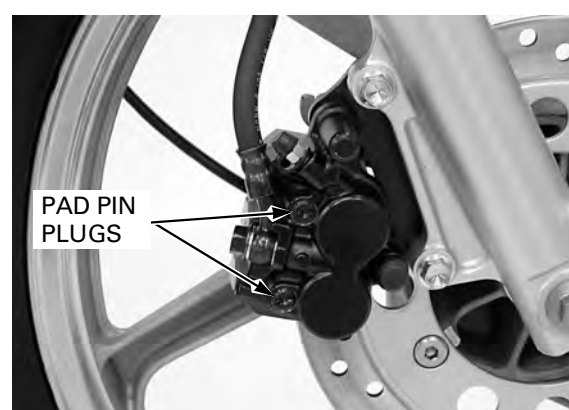

BRAKE DISC INSPECTION

Visually inspect the brake disc for damage or crack. Measure the brake disc thickness at several points.

SERVICE LIMIT: 3.5 mm (0.14 in)

Replace the brake disc if the smallest measurement is less than service limit.



Check the brake disc for runout.

SERVICE LIMIT: 0.25 mm (0.010 in)

Check the wheel bearings for excessive play, if the warpage exceeds the service limit. Replace the brake disc if the wheel bearings are normal.

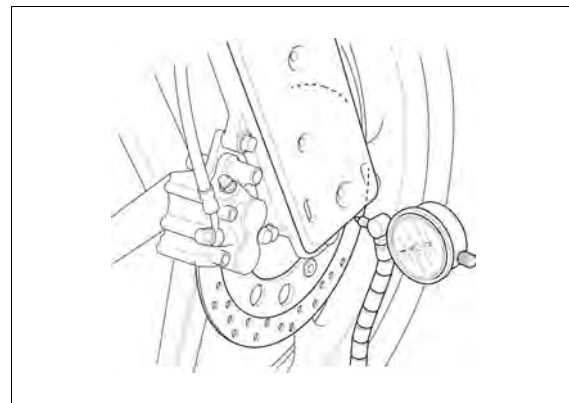

HYDRAULIC BRAKE

MASTER CYLINDER

REMOVAL

Drain the brake fluid from the hydraulic system (page 14-5).

Remove the right rear view mirror (page 12-7).

Remove the screws, reservoir cap, diaphragm plate and diaphragm.

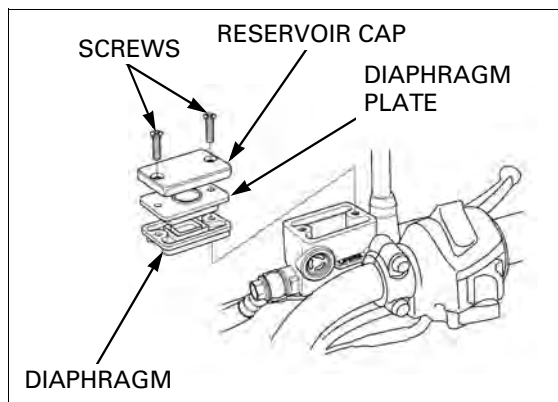

Disconnect the brake light switch connectors.

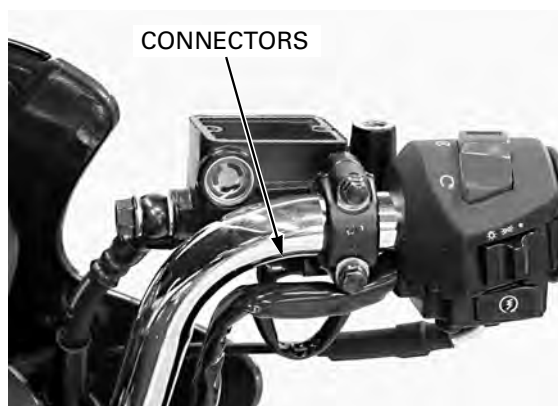

Disconnect the brake hose from the master cylinder by removing the oil bolt and sealing washers.

Remove the master cylinder holder bolts, holder and master cylinder.

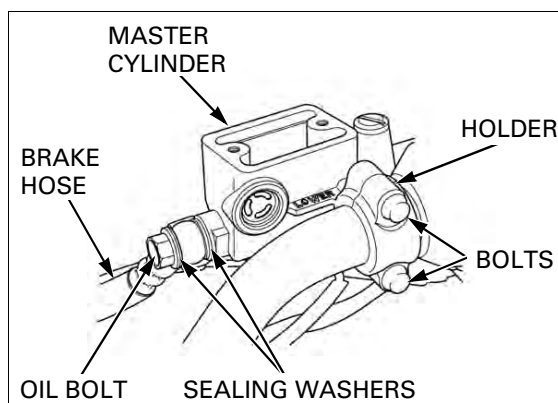

DISASSEMBLY

Remove the brake lever pivot nut, bolt and brake lever.

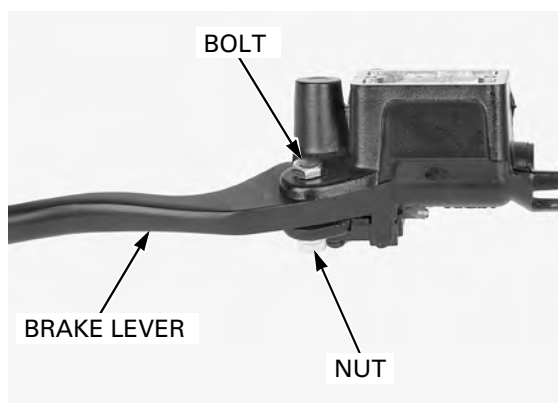

HYDRAULIC BRAKE

Remove the screw and brake light switch.

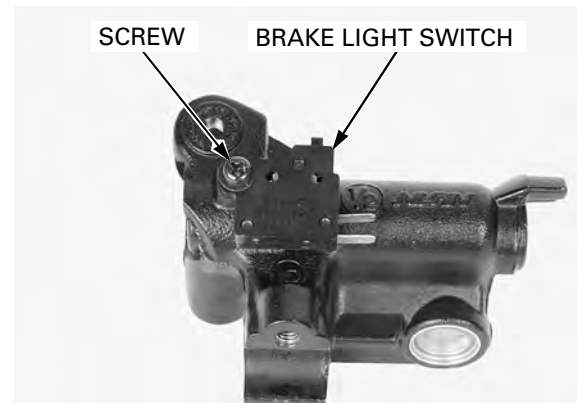

Remove the boot from the master piston.



Remove the snap ring using the special tool.

TOOL:
Snap ring pliers **07914-SA50001**



Remove the master piston and spring.
Clean the master cylinder, reservoir and master piston in clean brake fluid.

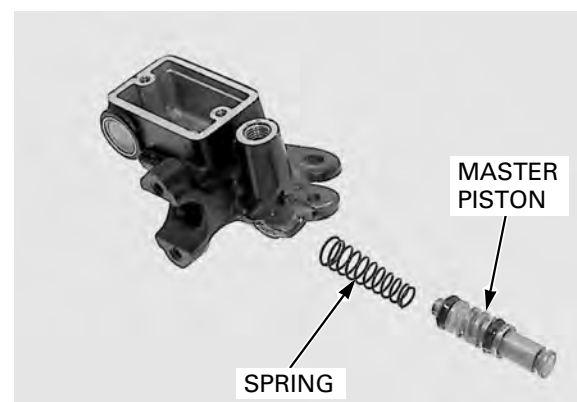

HYDRAULIC BRAKE

INSPECTION

Check the master piston for scoring, scratches or damage.

Check the piston cups for wear, deterioration or damage.

Check the master cylinder for scoring, scratches or damage.

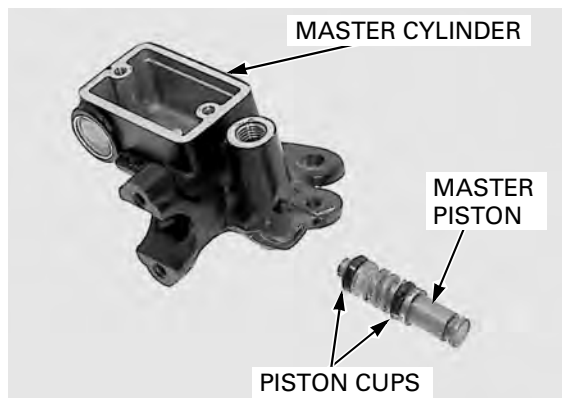

Measure the master cylinder I.D.

SERVICE LIMIT: 12.755 mm (0.5022 in)



Measure the master piston O.D.

SERVICE LIMIT: 12.645 mm (0.4978 in)



ASSEMBLY

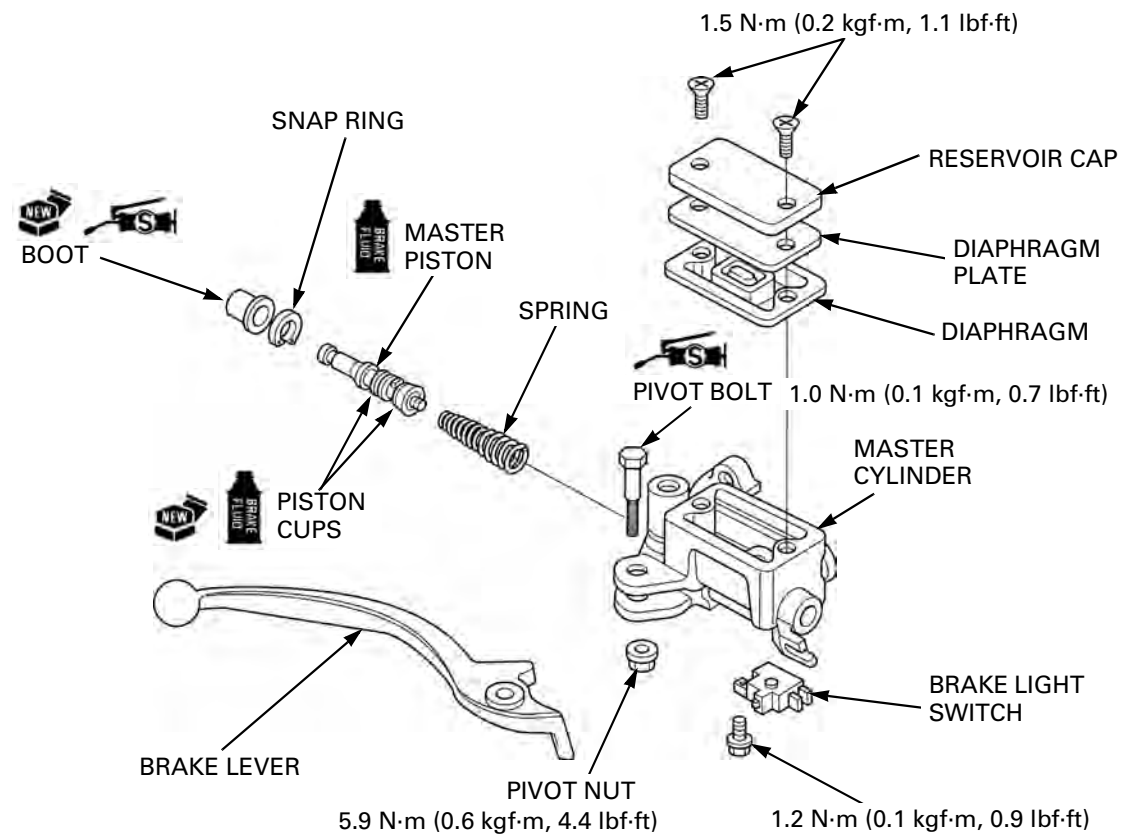

Keep the piston, cups, spring, snap ring and boot as a set; do not substitute individual part.

Coat a new piston cups and piston with clean DOT 3 or DOT 4 brake fluid.

Install the spring onto the piston end.

Do not allow the piston cup lips to turn inside out.

Install the spring, master piston and washer into the master cylinder.

Be certain the snap ring is firmly seated in the groove.

Install the snap ring into the groove in the master cylinder.

TOOL:
Snap ring pliers

07914-SA50001

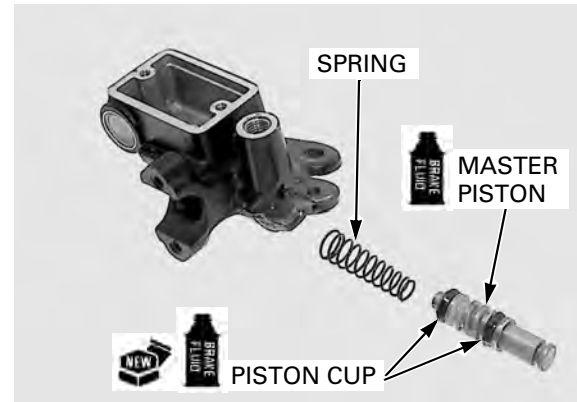

HYDRAULIC BRAKE

Install a new boot onto the master piston.
Apply silicone grease to the brake lever-to-master piston contact area.



Install the brake light switch to the master cylinder, aligning the brake light switch boss and master cylinder hole.

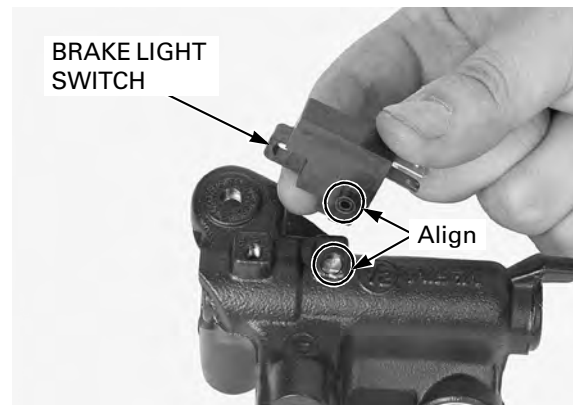

Install the brake light switch, screw and tighten it to the specified torque.

TORQUE: 1.2 N·m (0.1 kgf·m, 0.9 lbf·ft)

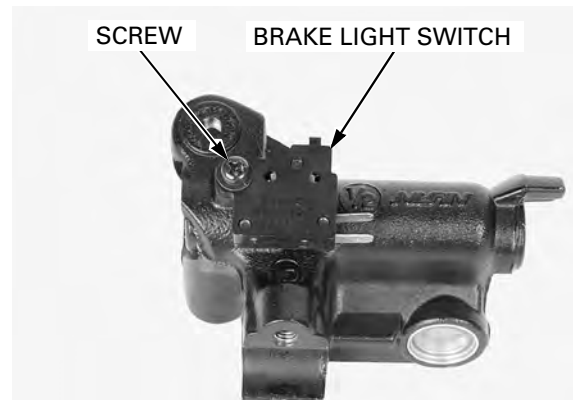

Apply silicone grease to the brake lever pivot bolt rotating surface.

Install the brake lever to the master cylinder.

Install the pivot bolt and tighten it to the specified torque.

TORQUE: 1.0 N·m (0.1 kgf·m, 0.7 lbf·ft)

Install the pivot nut and tighten it to the specified torque.

TORQUE: 5.9 N·m (0.6 kgf·m, 4.4 lbf·ft)

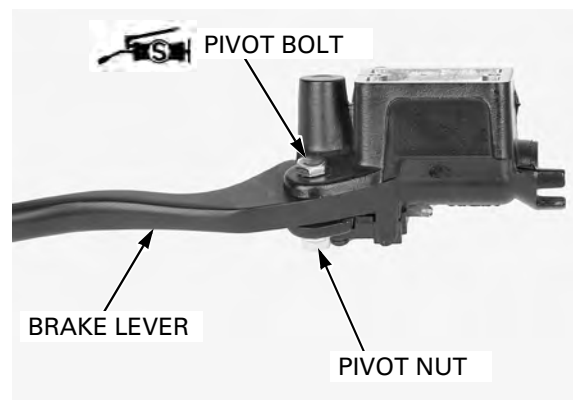

INSTALLATION

Set the master cylinder and the holder to the handlebar with its "UP" mark facing up.

Align the mating surface of the master cylinder with the punch mark on the handlebar, and tighten the upper bolt first, then tighten the lower bolt.

Set the brake hose joint between the stoppers on the master cylinder.

Connect the brake hose with the oil bolt and new sealing washers, and tighten the oil bolt to the specified torque.

TORQUE: 34 N·m (3.5 kgf·m, 25 lbf·ft)

Connect the brake light switch connectors.

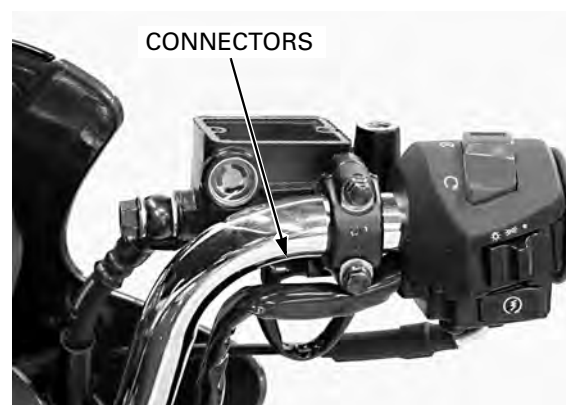
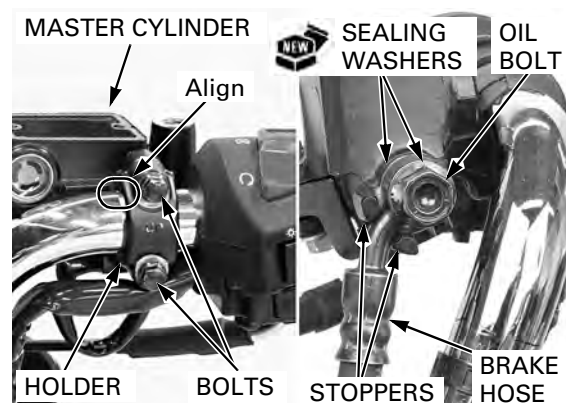

Fill the brake fluid and bleed the air from the hydraulic system (page 14-5).

Install the diaphragm, diaphragm plate, reservoir cap and screws.

Tighten the screws to the specified torque.

TORQUE: 1.5 N·m (0.2 kgf·m, 1.1 lbf·ft)

Install the right rear view mirror (page 12-11).

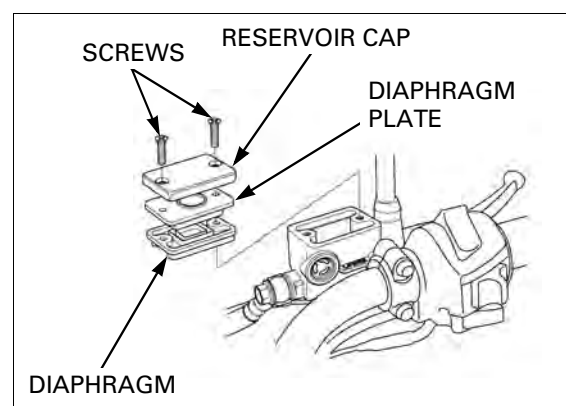

BRAKE CALIPER

REMOVAL

Drain the brake fluid from the hydraulic system (page 14-5).

Disconnect the brake hose from the brake caliper by removing the oil bolt and sealing washers.

Remove the two mounting bolts and brake caliper.

Remove the brake pads (page 14-7).

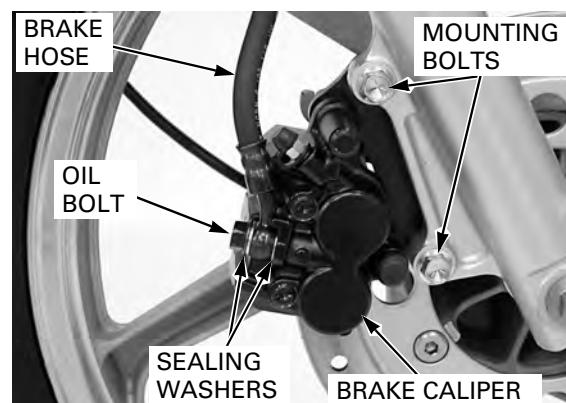

HYDRAULIC BRAKE

DISASSEMBLY

Remove the following:

- Bracket
- Pad spring
- Caliper pin boots

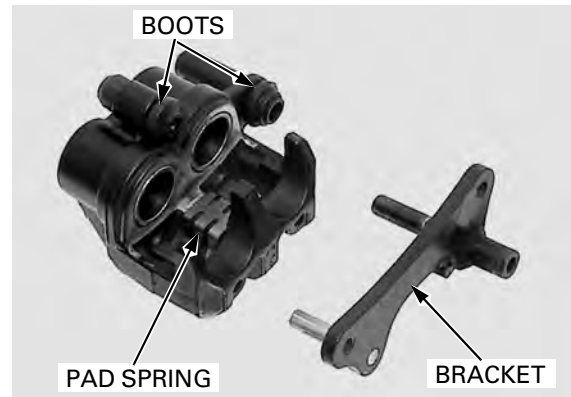

Place a shop towel over the piston.

Do not use high pressure air or bring the nozzle too close to the inlet.

Position the caliper body with the piston down and apply small squirts of air pressure to the fluid inlet to remove the piston.



Be careful not to damage the piston sliding surface.

Push the dust seal and piston seal in and lift them out.

Clean the seal grooves, caliper cylinder and piston with clean brake fluid.

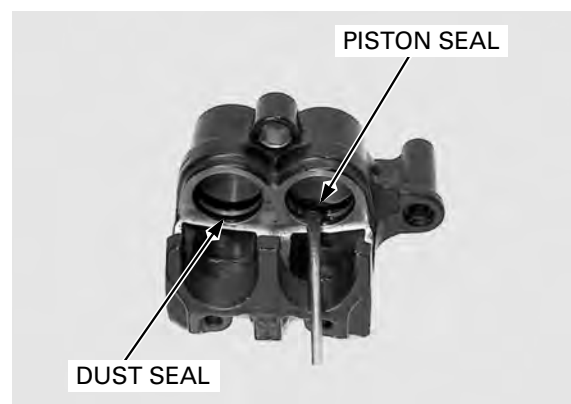

INSPECTION

Check the caliper cylinder for scoring, scratches or damage.

Measure the caliper cylinder I.D.

SERVICE LIMIT: 25.460 mm (1.0024 in)



HYDRAULIC BRAKE

Check the caliper piston for scoring, scratches or damage.

Measure the caliper piston O.D.

SERVICE LIMIT: 25.31 mm (0.996 in)

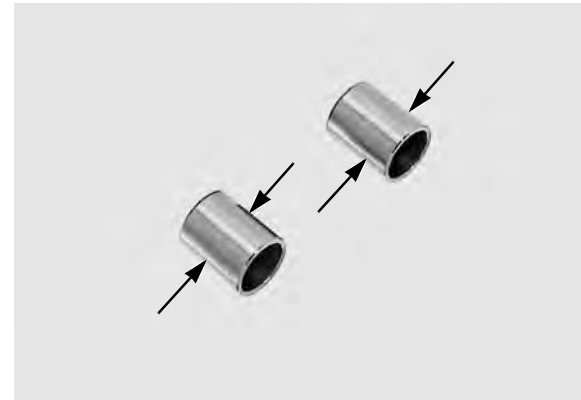

ASSEMBLY

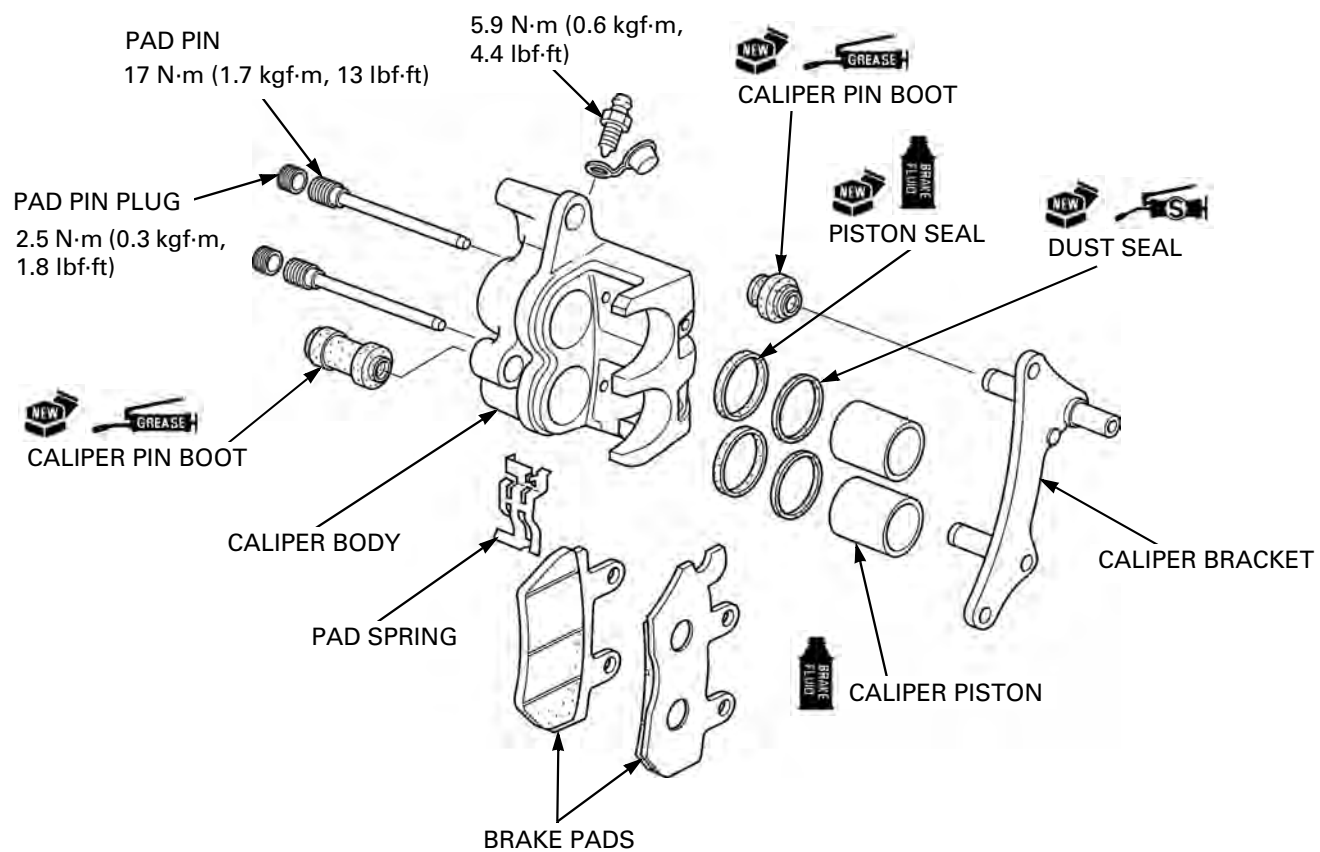

Coat a new piston seal with clean DOT 3 or DOT 4 brake fluid.

Apply silicone grease to the new dust seals.

Install the new piston seals and new dust seals into the seal grooves in the caliper cylinder.

Coat the caliper pistons with clean DOT 3 or DOT 4 brake fluid and install them into the caliper cylinders with the opening side facing the pad.



HYDRAULIC BRAKE

Install the pad spring onto the caliper body.

Apply grease to the inside of new pin boots, and install them into the caliper body.

Install the caliper bracket.

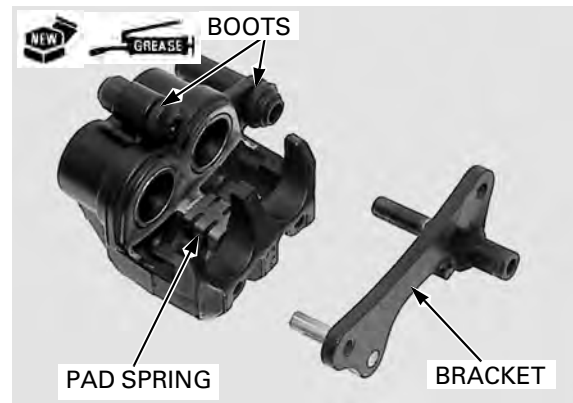

INSTALLATION

Install the brake pads (page 14-7).

Install the brake caliper onto the right fork leg. Install new mounting bolts and tighten them to the specified torque.

TORQUE: 26 N·m (2.7 kgf·m, 19 lbf·ft)

Connect the brake hose to the brake caliper with the oil bolt and new sealing washers. Set the hose joint between the stoppers and tighten the oil bolt to the specified torque.

TORQUE: 34 N·m (3.5 kgf·m, 25 lbf·ft)

Fill the brake fluid and bleed the air from the hydraulic system (page 14-5).

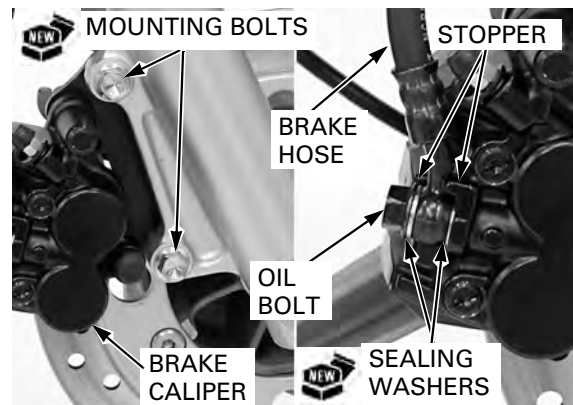

15. BATTERY/CHARGING SYSTEM

COMPONENT LOCATION	15-2	BATTERY.....	15-6
SYSTEM DIAGRAM.....	15-2	CHARGING SYSTEM INSPECTION.....	15-9
SERVICE INFORMATION	15-3	REGULATOR/RECTIFIER	15-10
TROUBLESHOOTING	15-5	ALTERNATOR CHARGING COIL	15-11

BATTERY/CHARGING SYSTEM
COMPONENT LOCATION

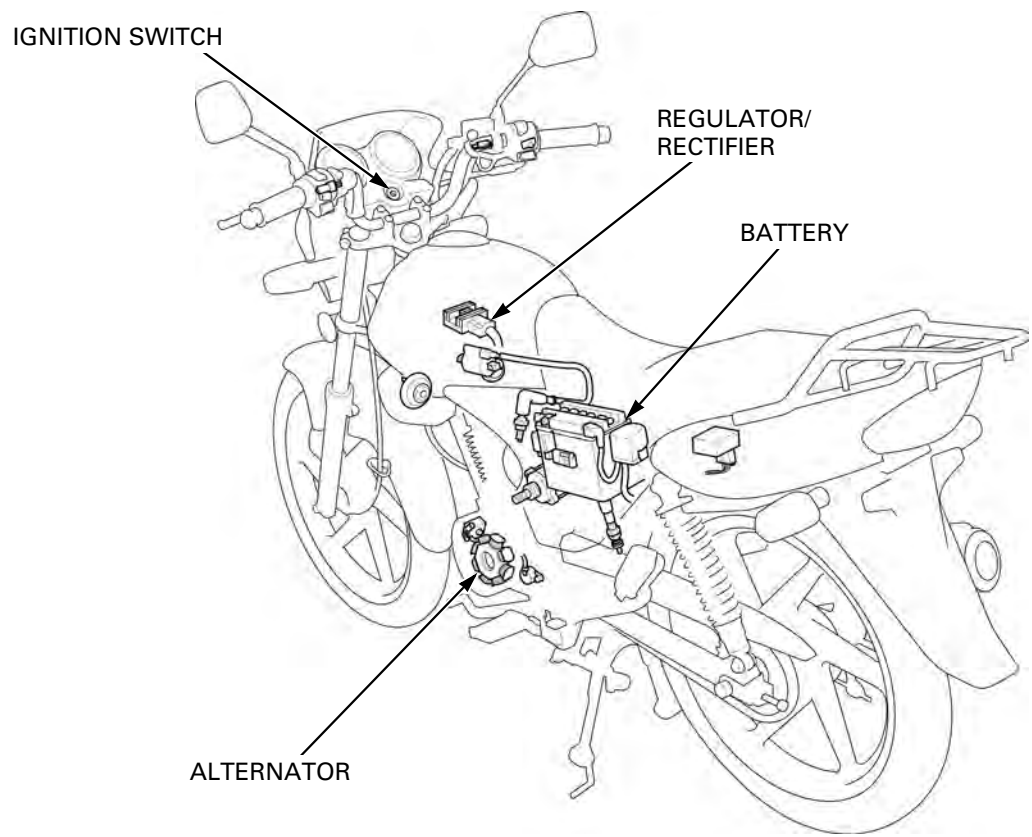

SYSTEM DIAGRAM

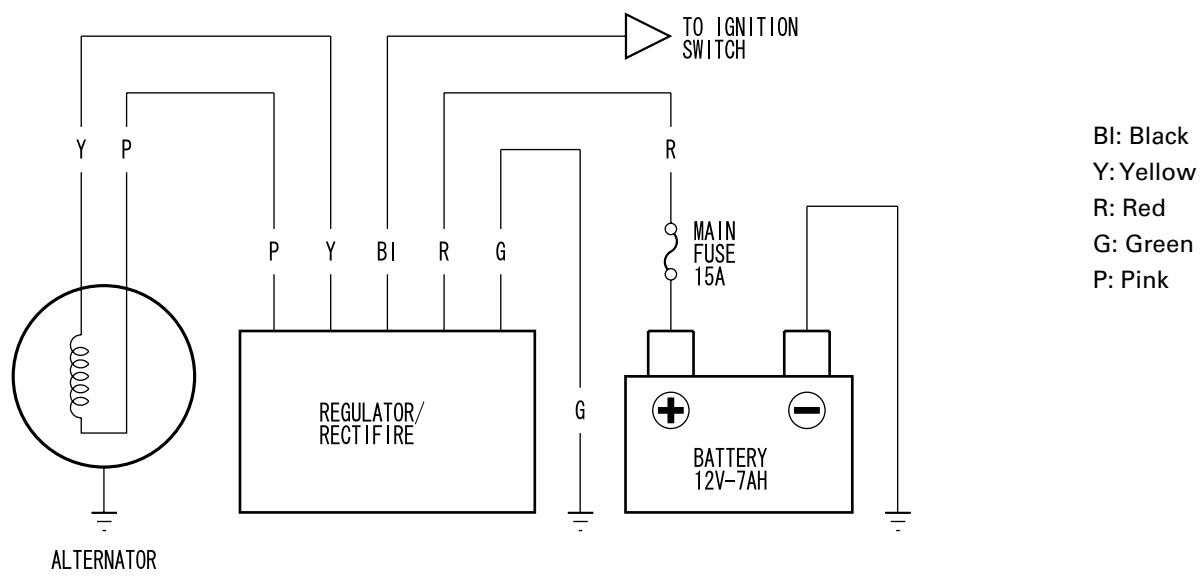

SERVICE INFORMATION**GENERAL****⚠ WARNING**

- The battery gives off explosive gases; keep sparks, flames and cigarettes away. Provide adequate ventilation when charging.
- The battery contains sulfuric acid (electrolyte). Contact with skin or eyes may cause severe burns. Wear protective clothing and a face shield.
 - If electrolyte gets on your skin, flush with water.
 - If electrolyte gets in your eyes, flush with water for at least 15 minutes and call a physician immediately.
- Electrolyte is poisonous.
 - If swallowed, drink large quantities of water or milk and call your local Poison Control Center or call a physician immediately.

NOTICE

- *Always turn "OFF" the ignition switch before disconnecting any electrical component.*
- *Some electrical components may be damaged if terminals or connectors are connected or disconnected while the ignition switch is in the "ON" position and current is present.*
- *If the breather hose is blocked, the battery's internal pressure will not be relieved and the breather may come off, or the battery may crack as a result.*
- For extended storage, remove the battery, give it a full charge, and store it in a cool, dry space. For maximum service life, charge the stored battery every two weeks.
- For a battery remaining in a stored motorcycle, disconnect the negative battery cable from the battery terminal.
- Tap water will shorten the service life of the battery.
- Immediately wash off any spilled electrolyte.
- The battery can be damaged if overcharged or undercharged, or if left to discharge for long period. These same conditions contribute to shortening the "life span" of the battery. Even under normal use, the performance of the battery deteriorates after 2–3 years.
- Battery voltage may recover after battery charging, but under heavy load, battery voltage will drop quickly and eventually die out. For this reason, the charging system is often suspected as the problem. Battery overcharging often results from problems in the battery itself, which may appear to be an overcharging symptom. If one of the battery cells is shorted and battery voltage does not increase, the regulator/rectifier supplies excess voltage to the battery. Under these conditions, the electrolyte level goes down quickly.
- Before troubleshooting the charging system, check for proper use and maintenance of the battery. Check if the battery is frequently under heavy load, such as having the headlight and taillight "ON" for long periods of time without riding the motorcycle.
- The battery will self-discharge when the motorcycle is not in use. For this reason, charge the battery every two weeks to prevent sulfation from occurring.
- Filling a new battery with electrolyte will produce some voltage, but in order to achieve its maximum performance, always charge the battery. Also, the battery life is lengthened when it is initially charged.
- When checking the charging system, always follow the steps in the troubleshooting flow chart (page 15-5).
- For alternator service, See page 15-9.

Battery charging

For battery charging, do not exceed the charging current and time specified on the battery. Using excessive current or extending the charging time may damage the battery.

Battery testing

Refer to the battery instruction of the Operation Manual for the recommended battery tester. The recommended battery tester puts a "load" on the battery so the actual battery condition of the load can be measured.

Recommended battery tester **BM210 or BATTERY MATE or equivalent**

TROUBLESHOOTING**BATTERY IS DAMAGED OR WEAK****1. BATTERY TEST**

Remove the battery (page 15-6).

Check the battery condition using the recommended battery tester.

RECOMMENDED BATTERY TESTER: BM210 or BATTERY MATE or equivalent

Is the battery in good condition?

NO – Faulty battery.

YES – GO TO STEP 2.

2. CURRENT LEAKAGE TEST

Install the battery (page 15-6).

Check the battery current leakage test (Leak test; page 15-9).

Is the current leakage below 0.1 mA?

YES – GO TO STEP 4.

NO – GO TO STEP 3.

3. CURRENT LEAKAGE TEST WITHOUT REGULATOR/RECTIFIER CONNECTED

Disconnect the regulator/rectifier connector and recheck the battery current leakage.

Is the current leakage below 0.1 mA?

YES – Faulty regulator/rectifier

NO – • Shorted wire harness
• Faulty engine stop switch

4. CHARGING VOLTAGE INSPECTION

Measure and record the battery voltage using a digital multimeter (page 15-7).

Start the engine.

Measure the charging voltage (page 15-9).

Compare the measurements to the results of the following calculation.

STANDARD:

Measured battery Voltage < Measured charging voltage < 15.5 V

Is the measured charging voltage within the standard voltage?

YES – Faulty battery

NO – GO TO STEP 5.

5. ALTERNATOR CHARGING COIL INSPECTION

Check the alternator charging coil (page 15-11).

Is the alternator charging coil resistance within 0.3 – 1.2 Ω (20°C/68°F)?

NO – Faulty charging coil.

YES – GO TO STEP 6.

6. REGULATOR/RECTIFIER SYSTEM INSPECTION

Check the voltage and resistance at the regulator/rectifier connector (page 15-10).

Are the measurements correct?

YES – Faulty regulator/rectifier

NO – • Open circuit in related wire
• Loose or poor contacts of related terminal
• Shorted wire harness

BATTERY/CHARGING SYSTEM

BATTERY

REMOVAL/INSTALLATION

Always turn the ignition switch "OFF" before removing the battery.

Remove the left side cover (page 2-3).

Remove the bolt and disconnect the battery negative (-) cable from the battery.

Remove the bolt and disconnect the battery positive (+) cable from the battery.

Disconnect the battery breather hose.

Remove the two bolts, battery holder and battery.

Connect the positive terminal first, then the negative cable.

Install the battery in the reverse order of removal.

TORQUE: BATTERY HOLDER BOLT
1.8 N·m (0.2 kgf·m, 1.3 lbf·ft)

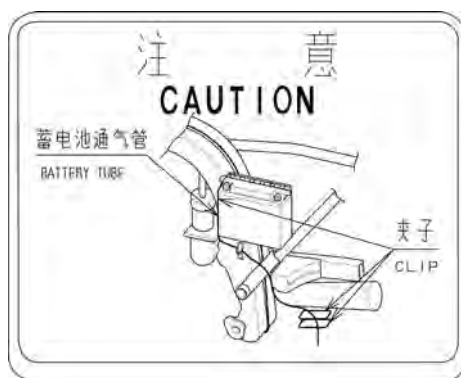
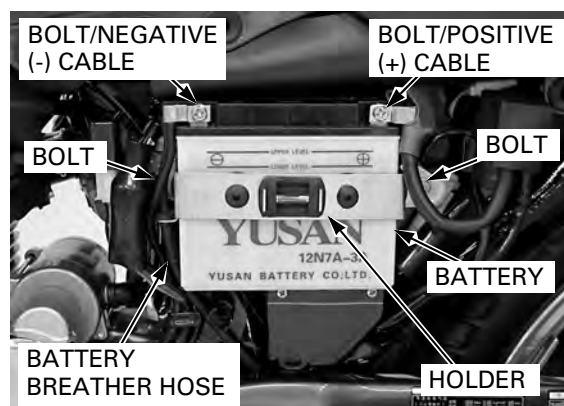

After installing the battery, coat the terminals with clean grease.

- Make sure that the battery breather hose is correctly positioned, and not kinked, trapped or bent in such a way as to obstruct the passage of the air.

BATTERY INSPECTION

Remove the battery (page 15-6).

Check for cracked or broken case or plates.

Check the plates for sulfation.

Replace the battery if damaged or sulfated.

Check the each cell's electrolyte level.

If low, add distilled water to bring the level to the upper level mark.

- In order to obtain an accurate test reading when checking the charging system, the battery must be fully charged and in good condition. Perform the following inspections and tests before attempting to troubleshoot charging system problems.

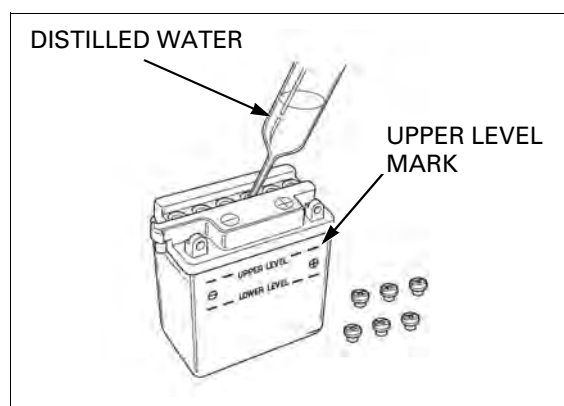

SPECIFIC GRAVITY

- The battery electrolyte contains sulfuric acid. Avoid contact with skin, eyes or clothing.

The specific gravity must be checked with a hydrometer.

Test each cell by drawing electrolyte into the hydrometer.

SPECIFIC GRAVITY:

Fully charged: 1.270 – 1.290 (20°C/68°F)

Needs charging: Below 1.230 (20°C/68°F)

- If the difference in specific gravity between cells exceeds 0.01, re-charge the battery. If the difference in specific gravity is excessive, replace the battery.
- There is a change in specific gravity of approximately 0.007 per 10°C change in temperature. Be sure to consider this when taking measurements.
- Reading of the hydrometer's fluid level should be taken horizontally.

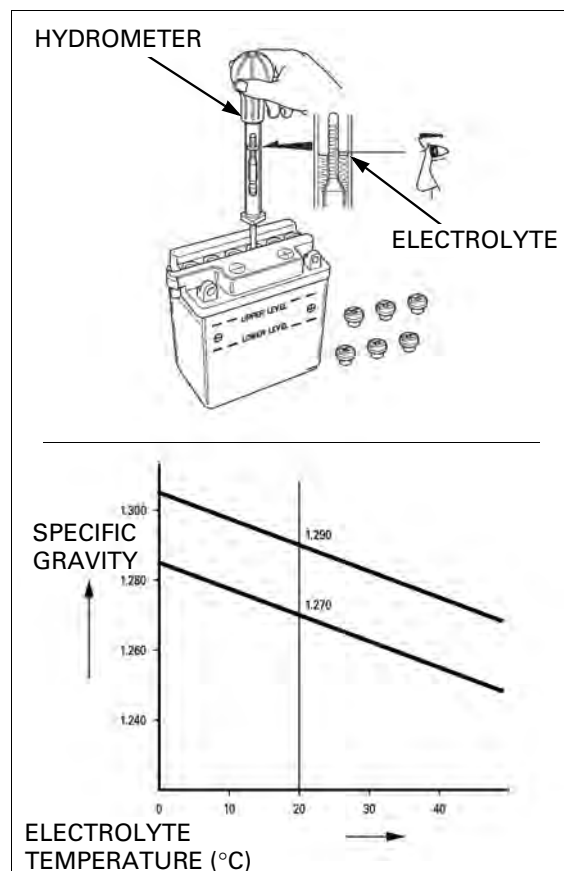

VOLTAGE INSPECTION

Remove the left side cover (page 2-3).

Measure the battery voltage using a digital multimeter.

VOLTAGE:

Fully charged: Above 12.8 V

Needs charging: Below 12.3 V

If the battery voltage is below 12.3 V, charge the battery (page 15-8).

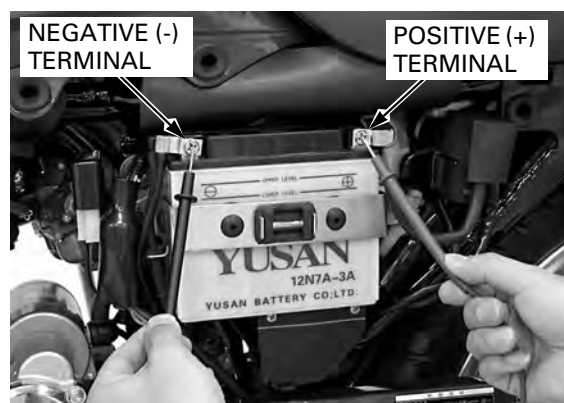

BATTERY/CHARGING SYSTEM

BATTERY CHARGING

- Keep flames and sparks away from a charging battery.

Remove the battery (page 15-6).

Before charging a battery, remove the cap from each cell.

Remove the cell caps.

Fill the cells with distilled water to the upper level line, if necessary.

Turn power ON/OFF at the charger, not at the battery terminal to prevent sparks.

Connect the charger positive (+) cable to the battery positive (+) terminal.

Connect the charger negative (-) cable to the battery negative (-) terminal.

- Quick-charging should only be done in an emergency; slow charging is preferred.
- For battery charging, do not exceed the charging current and time specified on the battery. Using excessive current or extending the charging time may damage the battery.
- Discontinue charging if the electrolyte temperature exceeds 45 °C (113 °F).

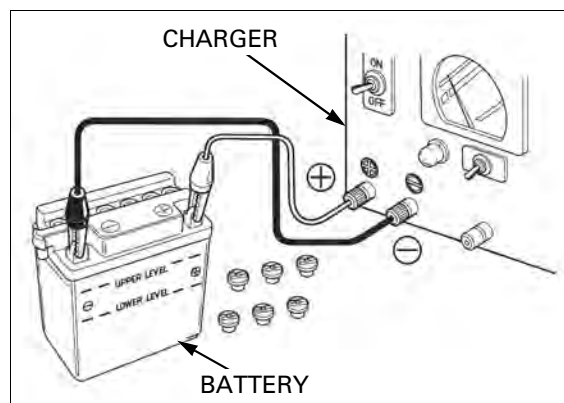

CHARGING CURRENT/TIME:

Normal: 0.8 A/5 – 10 h

Quick: 8 A/1 h

Charge the battery until specific gravity is 1.270–1.290.

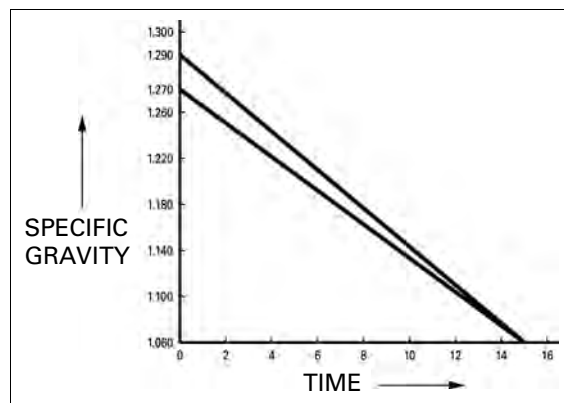

CHARGING SYSTEM INSPECTION

CURRENT LEAKAGE INSPECTION

Remove the left side cover (page 2-3).

Turn the ignition switch "OFF" and disconnect the battery negative (-) cable from the battery.

Connect the ammeter (+) probe to the battery negative (-) cable and the ammeter (-) probe to the battery negative (-) terminal.

With the ignition switch "OFF", check for current leakage.

- When measuring current using a tester, set it to a high range, and then bring the range down to an appropriate level. Current flow higher than the range selected may blow the fuse in the tester.
- While measuring current, do not turn the ignition switch "ON". A sudden surge of current may blow the fuse in the tester.

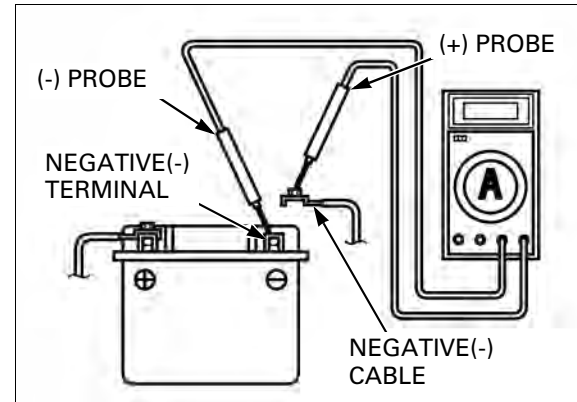

CURRENT LEAKAGE: 0.1 mA max.

If current leakage exceeds the specified value, a shorted circuit is likely.

Locate the short by disconnecting connections one by one and measuring the current.

CHARGING VOLTAGE INSPECTION

Before performing this test, be sure that the battery is fully charged and that the specific gravity is above 1.260.

Do not disconnect the battery or any cable in the charging system without first switching off the ignition switch. Failure to follow this precaution can damage the tester or electrical components.

Remove the left side cover (page 2-3).

Warm up the engine to normal operating temperature.

Stop the engine, and connect the multimeter as shown.

- To prevent a short, be absolutely certain which are the positive and negative terminals or cable.

Disconnect the battery negative (-) cable from the battery.

Measure and record the battery voltage using a commercially available digital multimeter.

Connect the battery negative (-) cable to the battery. Connect a voltmeter between the battery terminals

Restart the engine.

With the headlight on Hi beam, measure the voltage on the multimeter when the engine runs at 5,000 min⁻¹ (rpm).

Standard: Measured B V < Measured C V < 15.5 V

- B V = Battery voltage
- C V = Charging voltage

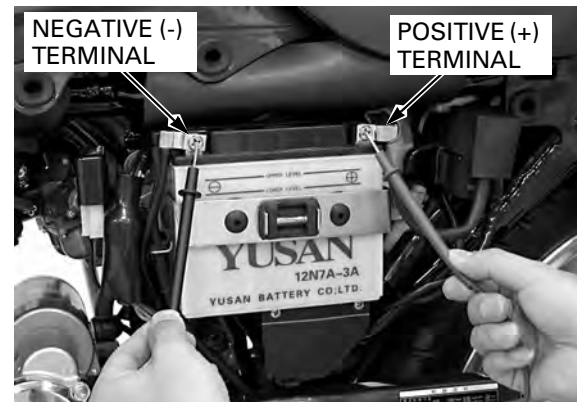

Be careful not to short any tester probes.

BATTERY/CHARGING SYSTEM

REGULATOR/RECTIFIER

SYSTEM INSPECTION

Remove the fuel tank (page 2-4).

Pull back the dust cover and disconnect the regulator/rectifier 6P connector, and check it for loose contact or corroded terminals.

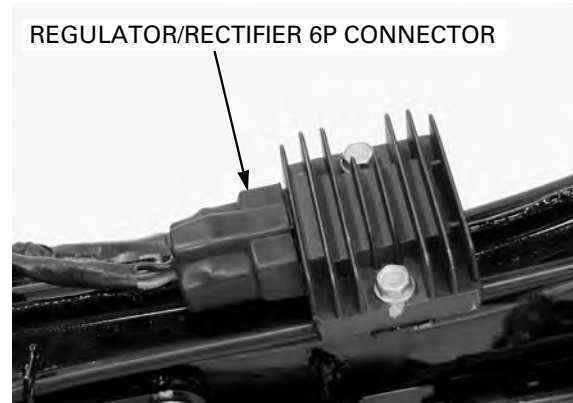

If the charging voltage reading (page 15-9) is out of the specification, turn the ignition switch "OFF", then check the voltage and resistance at the regulator/rectifier connector from the wire harness side.

Item	Terminal	Specification
Battery charging line	Red (+) and Green (-)	Battery voltage should register
Charging coil line	Yellow and Pink	0.3 – 1.2 Ω at (20°C/68°F)
Ground line	Green and ground	Continuity should exist

Turn the ignition switch "ON".

Measure the voltage at the regulator/rectifier connector from the wire harness side.

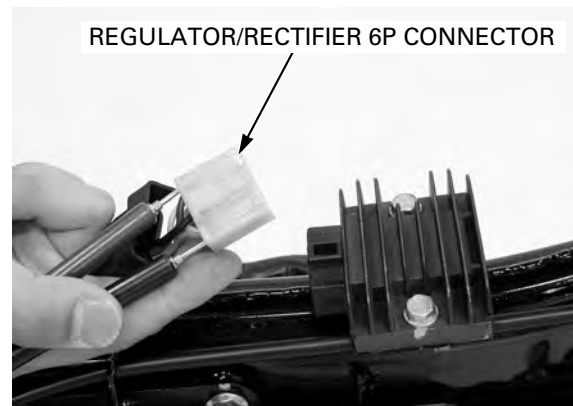

Item	Terminal	Specification
Voltage detection line	Black (+) and Green (-)	Battery voltage should register

If all components of the charging system are normal and there are no loose connections at the regulator/rectifier 6P connector, replace the regulator/rectifier unit.

REMOVAL/INSTALLATION

Remove the fuel tank (page 2-4).

Pull back the dust cover and disconnect the regulator/rectifier 6P connector.

Remove the two mounting bolts and regulator/rectifier.

Installation is in the reverse order of removal.

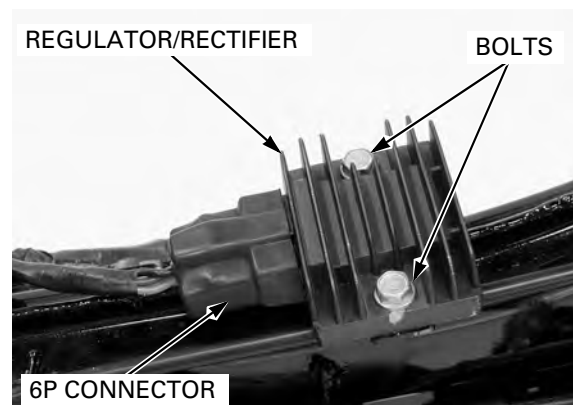

ALTERNATOR CHARGING COIL

INSPECTION

It is not necessary to remove the stator coil to perform this test.

Remove the left side cover (page 2-3).

Disconnect the Yellow and Pink alternator wire connectors.

Check the resistance between the following terminals of the alternator side wire connectors.

STANDARD: Yellow – Pink(Charging coil)
0.3 – 1.2 Ω (20°C/68°F)

If readings are far beyond the standard, replace the alternator stator (page 10-5).

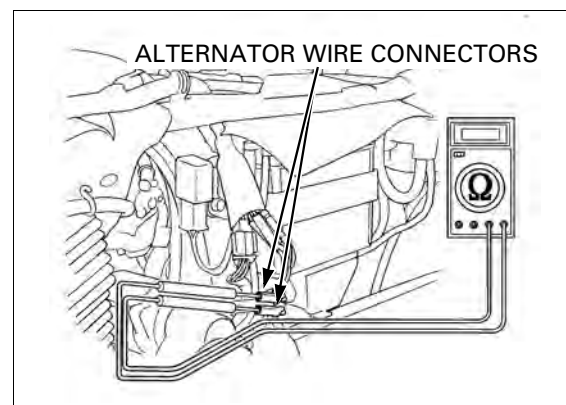

MEMO

16. IGNITION SYSTEM

COMPONENT LOCATION	16-2	IGNITION SYSTEM INSPECTION	16-5
SYSTEM DIAGRAM	16-2	IGNITION TIMING	16-8
SERVICE INFORMATION	16-3	IGNITION COIL	16-9
TROUBLESHOOTING	16-4	ICM (IGNITION CONTROL MODULE)	16-10

IGNITION SYSTEM

COMPONENT LOCATION

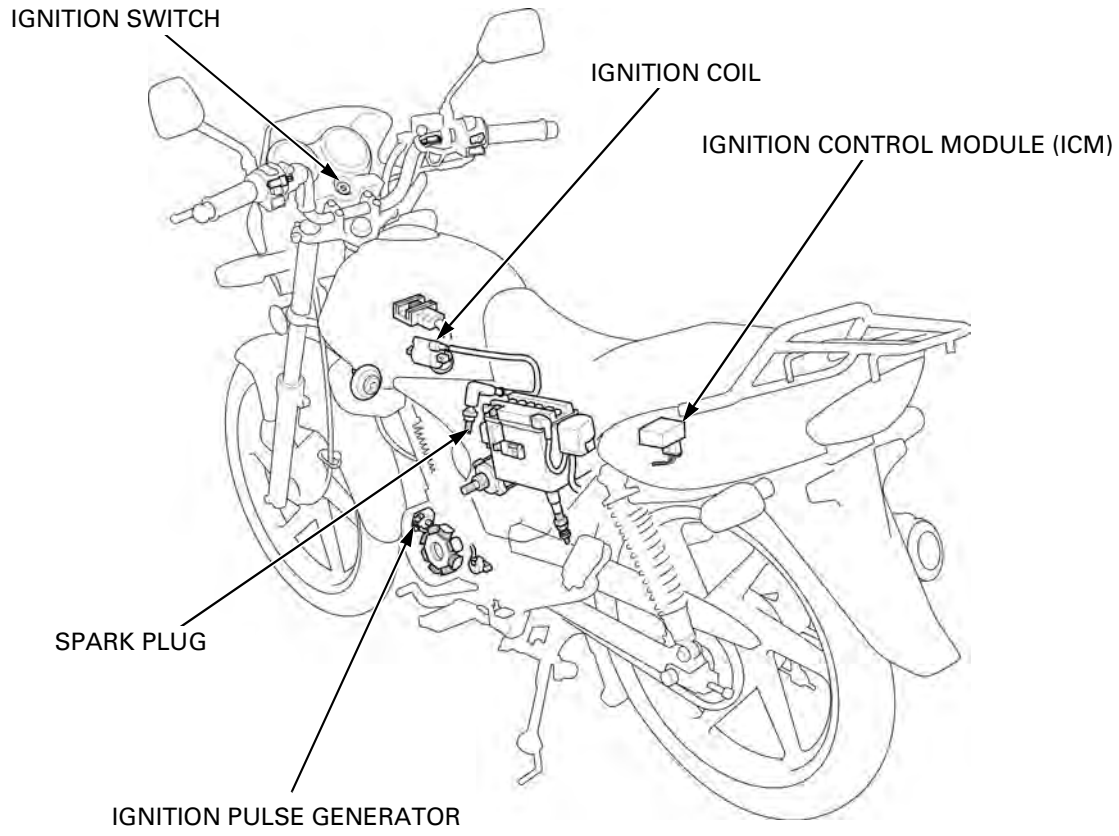

SYSTEM DIAGRAM

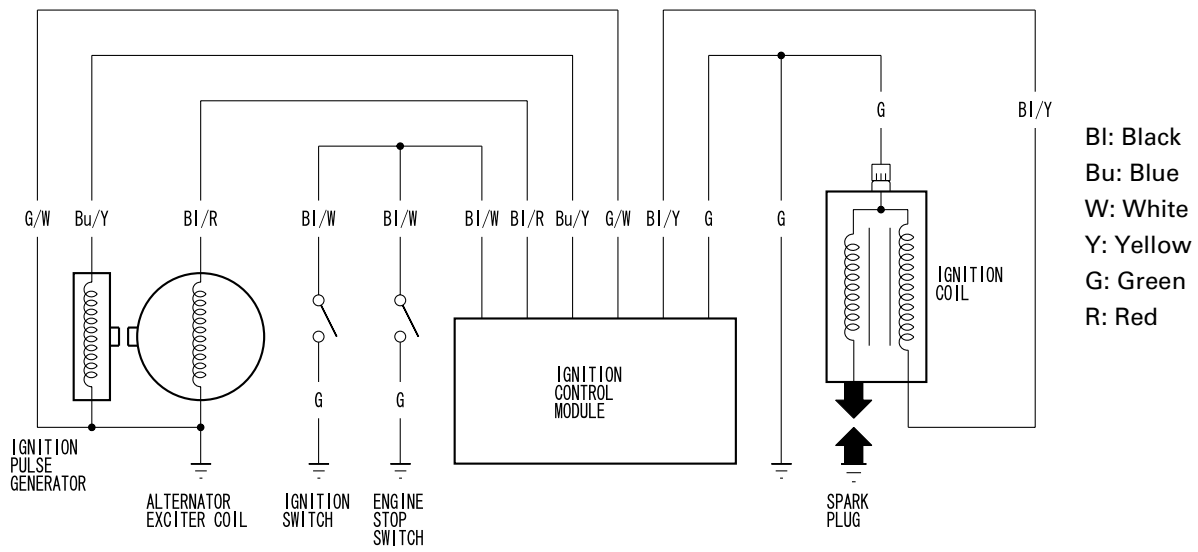

SERVICE INFORMATION

GENERAL

- When servicing the ignition system, always follow the steps in the troubleshooting sequence on page 16-4.
- The ignition timing cannot be adjusted since the Ignition Control Module (ICM) is factory preset.
- The Ignition Control Module (ICM) may be damaged if dropped. Also if the connector is disconnected when current is flowing, the excessive voltage may damage the module. Always turn off the ignition switch before servicing.
- A faulty ignition system is often related to poor connections. Check those connections before proceeding.
- Use spark plug of the correct heat range. Using a spark plug with an incorrect heat range can damage the engine.

SPECIFICATION

ITEM		SPECIFICATIONS
Spark plug	Standard	DPR8EA-9 (NGK)
	For extended high speed riding	DPR9EA-9 (NGK)
Spark plug gap		0.80 – 0.90 mm (0.031 – 0.035 in)
Ignition coil primary peak voltage		100 V minimum
Exciter coil peak voltage		100 V minimum
Ignition pulse generator peak voltage		0.7 V minimum
Ignition timing ("F" mark)		15° BTDC at idle

TORQUE VALUES

Timing hole cap 6 N·m (0.6 kgf·m, 4.4 lbf·ft)

TOOL

Peak voltage adaptor
07HGJ-0020100

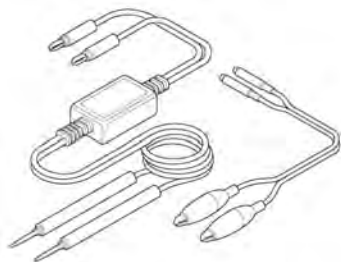

with commercially available digital multimeter (impedance 10 MΩ/DCV minimum)
or Imrie diagnostic tester (model 625)

IGNITION SYSTEM

TROUBLESHOOTING

Inspect the following before diagnosing the system.

- Loose spark plug cap or spark plug wire connection
- Loose spark plug cap or spark plug wire
- Water got into the spark plug cap (Leaking the ignition coil secondary voltage)

No spark at plug

	Unusual condition	Probable cause (check in numerical order)
Ignition coil primary voltage	Low peak voltage.	<ol style="list-style-type: none"> 1. The multimeter impedance is too low; below 10 MΩ/DCV. 2. Cranking speed is too slow. (Battery is undercharged.) 3. The sampling time of the tester and measured pulse were not synchronized. (System is normal if measured voltage is over the standard voltage at least once.) 4. Poorly connected connectors or an open circuit in the ignition system. 5. Faulty exciter coil. (Measure the peak voltage.) 6. Faulty ignition coil. 7. Faulty ignition control module (ICM) (in case when above No. 1 – 6 are normal).
	No peak voltage.	<ol style="list-style-type: none"> 1. Incorrect peak voltage adapter connections. 2. Short circuit in the engine stop switch Black/White wire. 3. Faulty ignition switch or engine stop switch. 4. Loose or poorly connected ICM connectors. 5. Open circuit or poor connection in the green wire of the ICM. 6. Faulty peak voltage adapter. 7. Faulty exciter coil. (Measure the peak voltage.) 8. Faulty ignition pulse generator. (Measure the peak voltage.) 9. Faulty ICM (in case when above No.1 – 8 are normal).
	Peak voltage is normal, but no spark at the plug.	<ol style="list-style-type: none"> 1. Faulty spark plug or leaking ignition coil secondary current. 2. Faulty ignition coil.
Exciter coil	Low peak voltage.	<ol style="list-style-type: none"> 1. The multimeter impedance is too low; below 10 MΩ/DCV. 2. Cranking speed is too slow. (Battery is undercharged.) 3. The sampling time of the tester and measured pulse were not synchronized. (System is normal if measured voltage is over the standard voltage at least once.) 4. Faulty exciter coil (in case when above No.1 – 3 are normal).
	No peak voltage.	<ol style="list-style-type: none"> 1. Faulty peak voltage adapter. 2. Faulty exciter coil.
Ignition pulse generator	Low peak voltage.	<ol style="list-style-type: none"> 1. The multimeter impedance is too low; below 10 MΩ/DCV. 2. Cranking speed is too slow. (Battery is undercharged.) 3. The sampling time of the tester and measured pulse were not synchronized. (System is normal if measured voltage is over the standard voltage at least once.) 4. Faulty ignition pulse generator (in case when above No.1 – 3 are normal).
	No peak voltage.	<ol style="list-style-type: none"> 1. Faulty peak voltage adapter. 2. Faulty ignition pulse generator.

IGNITION SYSTEM INSPECTION

- If there is no spark at the plug, check all connections for loose or poor contact before measuring the peak voltage.
- Use a commercially available digital multimeter with an impedance of 10 M Ω /DCV minimum.
- The display value differs depending upon the internal impedance of the multimeter.
- If using the Imrie diagnostic tester (model 625), follow the manufacturer's instructions.

Connect the peak voltage adaptor to the digital multimeter, or use the Imrie diagnostic tester.

TOOL:

**Imrie diagnostic tester (model 625) or
Peak voltage adaptor 07HGJ-0020100
with commercially available digital multimeter
(impedance 10 M Ω /DCV minimum)**

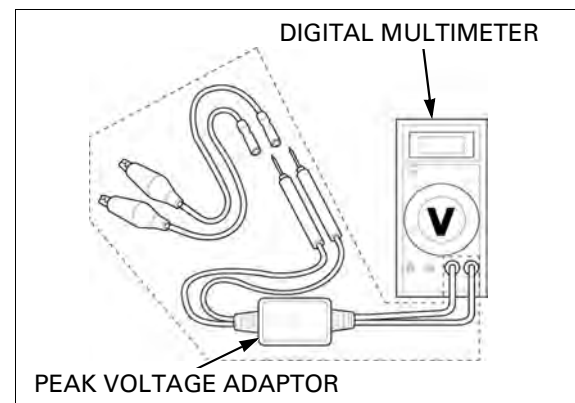

IGNITION COIL PRIMARY PEAK VOLTAGE

- Check all system connections before this inspection. Poor connected connectors can cause incorrect readings.
- Check the cylinder compression and check that the spark plug is installed correctly in the cylinder head.

Remove the fuel tank (page 2-4).

Disconnect the spark plug cap from the spark plug. Connect a known good spark plug to the spark plug cap and ground it to the cylinder head as done in a spark test.

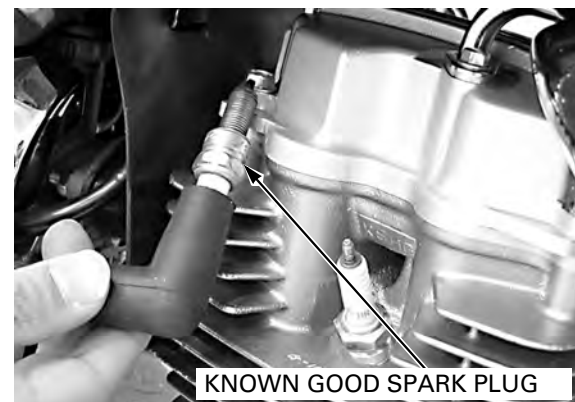

IGNITION SYSTEM

With the ignition coil primary wire connected, connect the peak voltage tester or adaptor probes to the ignition coil primary Black/Yellow wire terminal and body ground.

TOOL:

**Imrie diagnostic tester (model 625) or
Peak voltage adaptor 07HGJ-0020100
with commercially available digital multimeter
(impedance 10 M Ω /DCV minimum)**

CONNECTION:

Black/Yellow wire terminal (-) – Body ground (+)

Shift the transmission into neutral.
Turn the engine stop switch to "RUN" and ignition switch to "ON".

Crank the engine with the starter motor and read ignition coil primary peak voltage.

PEAK VOLTAGE: 100 V minimum

If the peak voltage is lower than the standard value, follow the checks described in the troubleshooting chart (page 16-4).

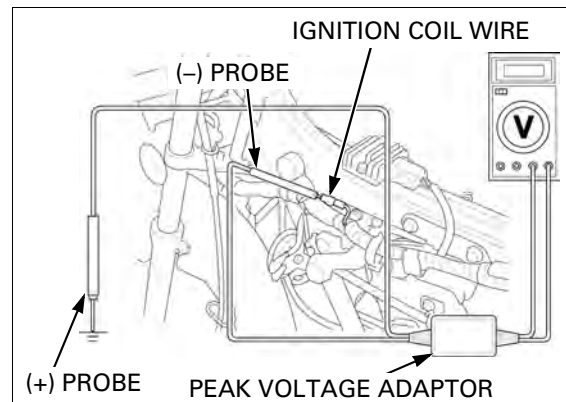

EXCITER COIL PEAK VOLTAGE

- Check the cylinder compression and check that the spark plug is installed correctly in the cylinder head.

Remove the right side cover (page 2-3).

Disconnect the ICM 3P and 4P connectors.
Connect the peak voltage tester or adaptor probes to the exciter coil wire terminal of the ICM 3P connector from the wire harness side and body ground.

TOOL:

**Imrie diagnostic tester (model 625) or
Peak voltage adaptor 07HGJ-0020100
with commercially available digital multimeter
(impedance 10 M Ω /DCV minimum)**

CONNECTION:

Black/Red wire terminal (+) – Body ground (-)

Shift the transmission into neutral.
Turn the engine stop switch to "RUN" and ignition switch to "ON".
Crank the engine with the starter motor and read exciter coil peak voltage.

PEAK VOLTAGE: 100 V minimum

If the peak voltage measured at the ICM connector is abnormal, measure the peak voltage at the exciter coil wire connector.

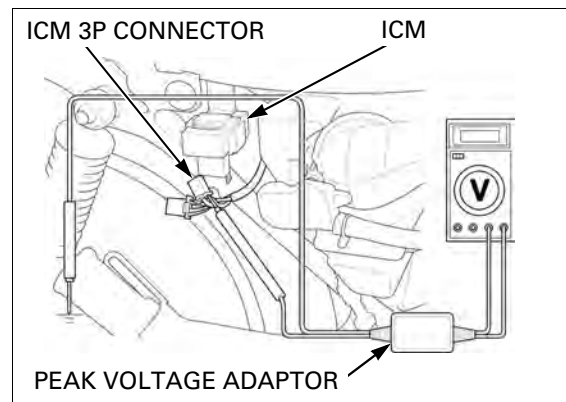

IGNITION SYSTEM

Remove the left side cover (page 2-3).

Disconnect the exciter coil Black/Red wire connector and connect the tester probes to the exciter coil side wire connector terminal and body ground.

In the same manner as at the ICM connector, measure the peak voltage and compare it to the voltage measured at the ICM connector.

- If the peak voltage measured at the ICM is abnormal and the one measured at the exciter coil is normal, the wire harness has an open or short circuit, or loose connection.
- If both peak voltages are abnormal, follow the checks described in the troubleshooting chart (page 16-4).

See page 10-5 for alternator stator replacement.

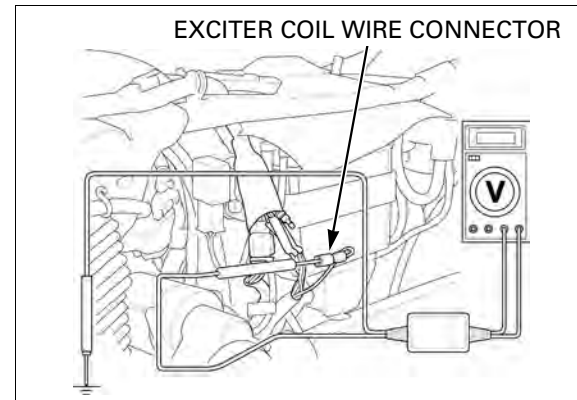

IGNITION PULSE GENERATOR PEAK VOLTAGE

- Check the cylinder compression and check that the spark plug is installed correctly in the cylinder head.

Remove the right side cover (page 2-3).

Disconnect the ICM 3P and 4P connectors. Connect the peak voltage tester or adaptor probes to the ignition pulse generator Blue/Yellow wire terminal of the ICM 4P connector from the wire harness side and body ground.

TOOL:

**Imrie diagnostic tester (model 625) or
Peak voltage adaptor 07HGJ-0020100
with commercially available digital multimeter
(impedance 10 M Ω /DCV minimum)**

CONNECTION:

Blue/Yellow wire terminal (+) – Body ground (-)

Shift the transmission into neutral.
Turn the engine stop switch to "RUN" and ignition switch to "ON".
Crank the engine with the starter motor and read ignition pulse generator peak voltage.

PEAK VOLTAGE: 0.7 V minimum

If the peak voltage measured at the ICM connector is abnormal, measure the peak voltage at the ignition pulse generator wire connector.

Remove the left side cover (page 2-3).

Disconnect the exciter coil wire connector and connect the tester probes to the Ignition pulse generator side Blue/Yellow wire connector terminal and body ground.

In the same manner as at the ICM connector, measure the peak voltage and compare it to the voltage measured at the ICM connector.

- If the peak voltage measured at the ICM is abnormal and the one measured at the Ignition pulse generator is normal, the wire harness has an open or short circuit, or loose connection.
- If both peak voltages are abnormal, follow the checks described in the troubleshooting chart (page 16-4).

See page 10-5 for alternator stator replacement.

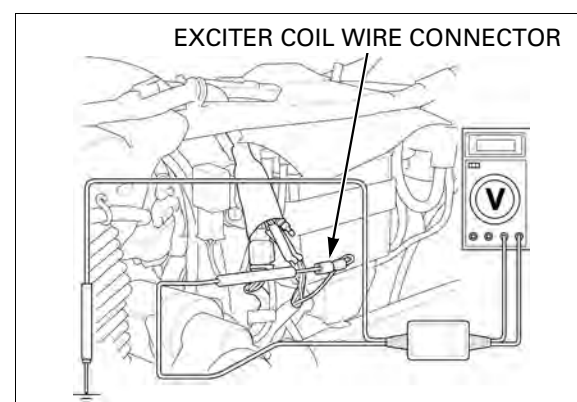
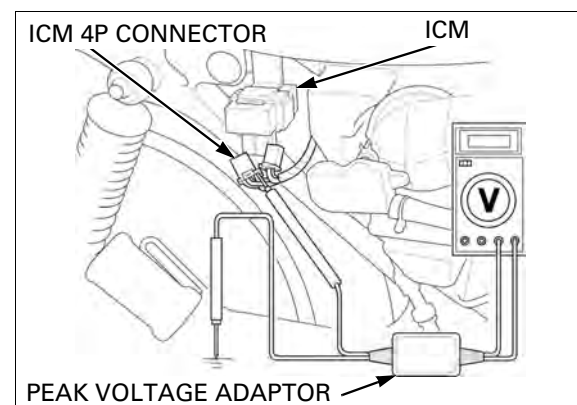

IGNITION SYSTEM

IGNITION TIMING

Warm up the engine.

Stop the engine and remove the timing hole cap and O-ring.

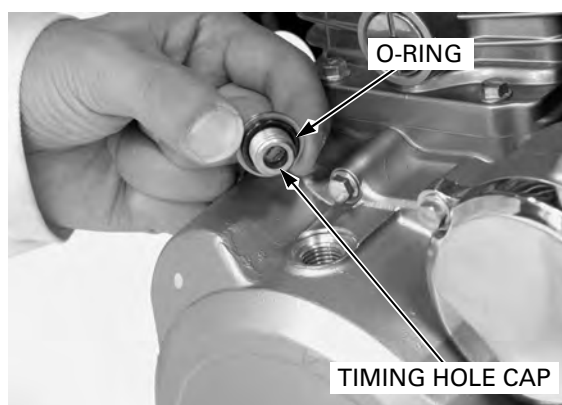

Read the instructions for timing light operation.

Connect a timing light to the spark plug wire.

Start the engine and let it idle.

IDLE SPEED: 1,400 ± 100 min⁻¹ (rpm)

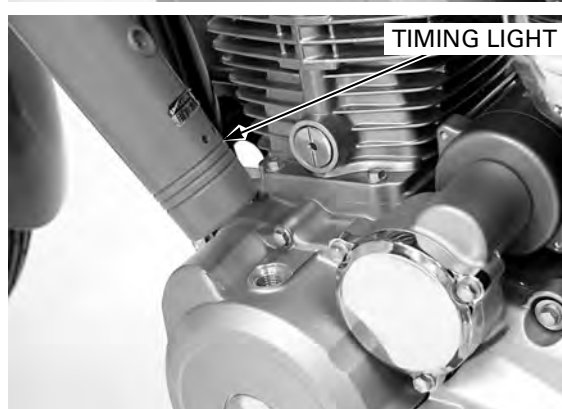

The ignition timing is correct if the "F" mark on the flywheel aligns with the index notch on the left crankcase cover.

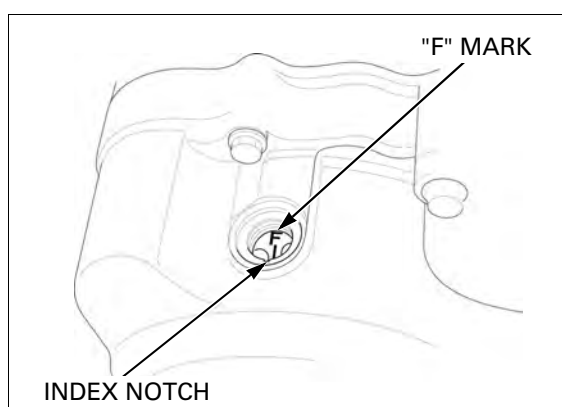

Coat a new O-ring with engine oil and install it onto the timing hole cap.

Install the timing hole cap and tighten it.

TORQUE: 6 N·m (0.6 kgf·m, 4.4 lbf·ft)

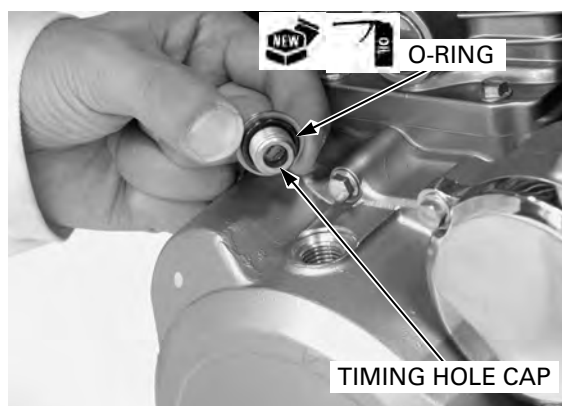

IGNITION COIL

REMOVAL/INSTALLATION

Remove the fuel tank (page 2-4).

Release the wire band and disconnect the primary wire connector from the ignition coil.

Disconnect the spark plug cap from the spark plug.
Remove the screws, ground terminal and ignition coil.

Installation is in the reverse order of removal.

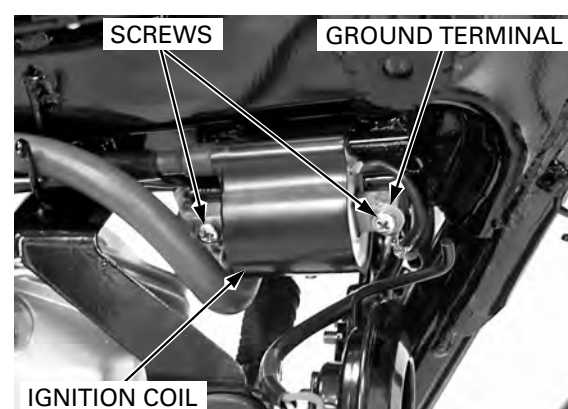

IGNITION SYSTEM

ICM (IGNITION CONTROL MODULE)

SYSTEM INSPECTION

Remove the right side cover (page 2-3).

Disconnect the ICM 4P and 3P connectors, and check for loose contact or corroded terminals.

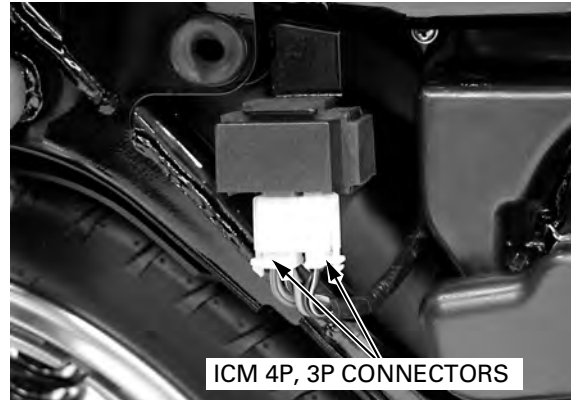

If the ignition system inspection (page 16-5) is normal, but no spark at plug, turn the ignition switch "OFF" and engine stop switch "OFF", then check the resistance at the ICM connector from the wire harness side.

Item	Terminal	Specification
Ignition switch and engine stop switch line	Black /White and Green	Continuity should exist
Ground line	Green and ground	Continuity should exist

Turn the ignition switch "ON" and engine stop switch "RUN".

Check for continuity at the ICM connector from the wire harness side.

Item	Terminal	Specification
Ignition switch and engine stop switch line	Black /White and Green	No continuity

If all components of the ignition system are normal and there are no loose connections at the ICM connectors, replace the ICM with a new one and recheck.

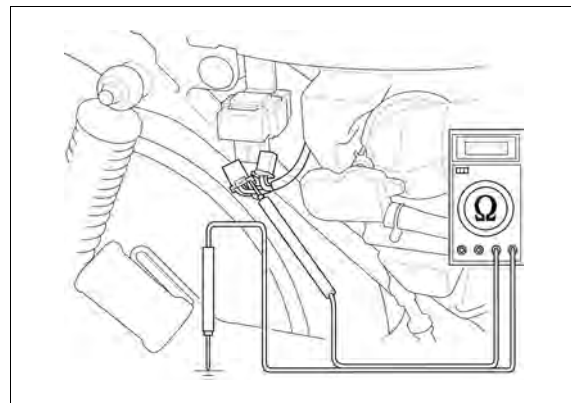

REMOVAL/INSTALLATION

Remove the right side cover (page 2-3).

Disconnect the ICM 4P and 3P connectors. Remove the ICM from the bracket.

Installation is in the reverse order of removal.

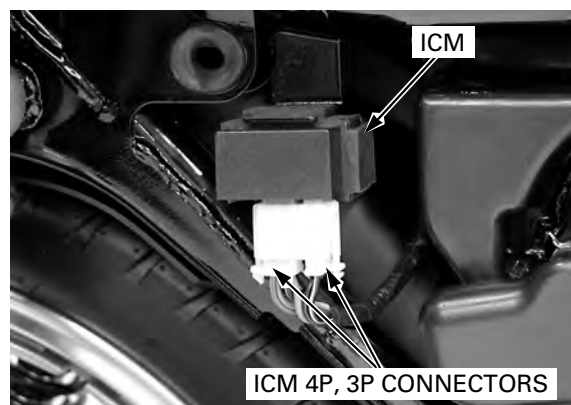

17. ELECTRIC STARTER

COMPONENT LOCATION	17-2	STARTER MOTOR	17-6
SYSTEM DIAGRAM.....	17-2	STARTER RELAY SWITCH.....	17-14
SERVICE INFORMATION	17-3	NEUTRAL DIODE	17-15
TROUBLESHOOTING	17-4		

ELECTRIC STARTER

COMPONENT LOCATION

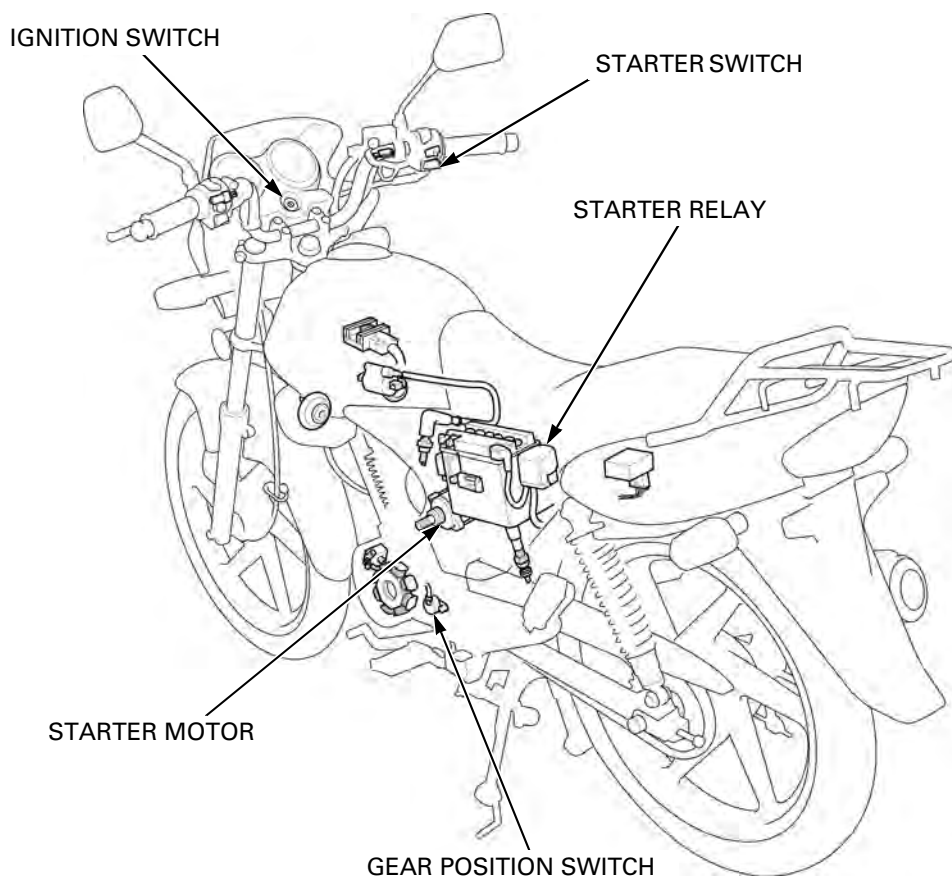

SYSTEM DIAGRAM

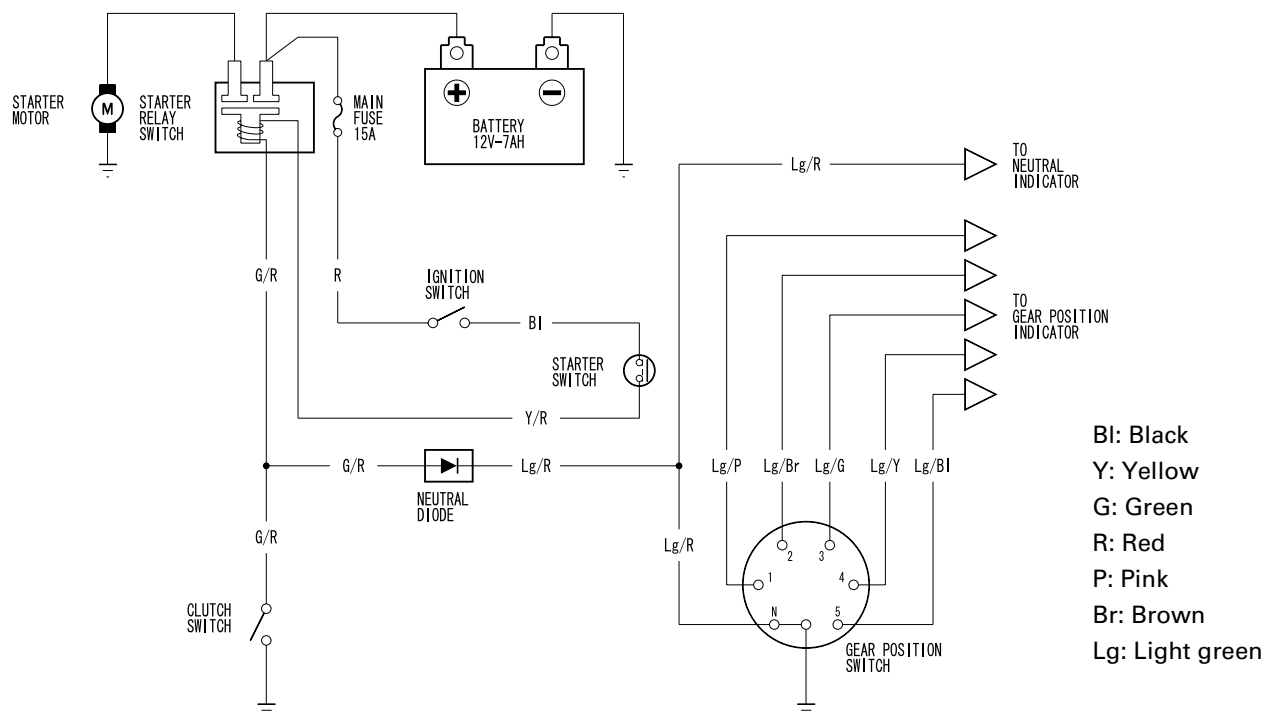

SERVICE INFORMATION**GENERAL**

- Always turn the ignition switch OFF before servicing the starter motor. The motor could suddenly start, causing serious injury.
- The starter motor can be serviced with the engine in the frame.
- When checking the starter system, always follow the steps in the troubleshooting (page 17-4).
- A weak battery may be unable to turn the starter motor quick enough, or supply adequate ignition current.
- If the current is kept flowing through the starter motor to turn it while the engine is not cranking over, the starter motor may be damaged.
- Refer to the following:
 - Starter clutch (page 10-7)
 - Ignition switch (page 18-9)
 - Starter switch (page 18-10)
 - Gear position switch (page 18-12)
 - Clutch switch (page 18-12)

SPECIFICATIONS

Unit: mm (in)

ITEM	STANDARD	SERVICE LIMIT
Starter motor brush length	12.5 (0.49)	6.5 (0.26)

ELECTRIC STARTER

TROUBLESHOOTING

NOTE:

- The starter motor should operate when the transmission is in neutral or when the clutch lever is squeezed.
- Make sure the engine stop switch is turned to "○" before starting the engine. The starter motor does not operate with the engine stop switch turned to "⊗".

Starter motor does not turn

1. Fuse Inspection

Check for blown fuse.

Is the fuse blown?

YES – Replace the fuse.

NO – GO TO STEP 2.

2. Battery Inspection

Make sure the battery is fully charged and in good condition.

Is the battery in good condition?

YES – GO TO STEP 3.

NO – Charge or replace the battery (page 15-8).

3. Battery Cable Inspection

Check the battery cables for loose or poorly connected terminal, and for an open circuit.

Is the terminal loose or poorly connected?

YES – • Loose or poorly connected battery cables.
• Open circuit in the battery cable.

NO – GO TO STEP 4.

4. Starter Motor Cable Inspection

Check the starter motor cable for loose or poorly connected terminal, and for an open circuit.

Is the terminal loose or poorly connected?

YES – • Loose or poorly connected starter motor cable.
• Open circuit in the starter motor cable.

NO – GO TO STEP 5.

5. Starter Relay Switch Operation Inspection

Check the operation of the starter relay switch (page 17-14).

Does the starter relay switch click?

YES – GO TO STEP 6.

NO – GO TO STEP 7.

6. Starter Motor Inspection

Connect the starter motor terminal to the battery positive terminal directly. (A large amount of current flows, so do not use a thin wire.)

Does the starter motor turn?

YES – Faulty starter relay switch.

NO – Faulty starter motor.

7. Relay Coil Ground Line Inspection

Check the ground line of the starter relay switch (page 17-14).

Is the ground line normal?

YES – GO TO STEP 8.

NO – • Faulty gear position switch (page 18-12).
• Faulty neutral diode (page 17-15).
• Faulty clutch switch (page 18-12).
• Loose or poor contact of the related connector terminal.
• Open circuit in the wire harness.

8. Relay Coil Power Input Line Inspection

Check the power input line of the starter relay switch (page 17-14).

Is the power input line normal?

YES – GO TO STEP 9.

NO –

- Faulty ignition switch (page 18-9).
- Faulty starter switch (page 18-10).
- Loose or poor contact of the related connector terminal.
- Open circuit in the wire harness.

9. Starter Relay Switch Inspection

Check the function of the starter relay switch (page 17-15).

Does the starter relay switch function properly?

NO – Faulty starter relay switch.

YES – Loose or poor contact of the starter relay switch connector.

Starter motor turns, but the engine turns slowly

- Low battery voltage
- Poorly connected battery cable
- Poorly connected starter motor cable
- Faulty starter motor
- Poorly connected ground cable terminal

Starter motor turns, but engine does not turn

- Starter motor is running backwards
 - Case assembled improperly
 - Terminals connected improperly
- Faulty starter clutch
- Damaged or faulty starter gear train

Starter relay switch clicks, but engine does not turn

- Crankshaft does not turn due to engine problems

ELECTRIC STARTER

STARTER MOTOR

REMOVAL

Slide the rubber cap off the starter motor terminal, and remove the terminal nut and starter motor cable.

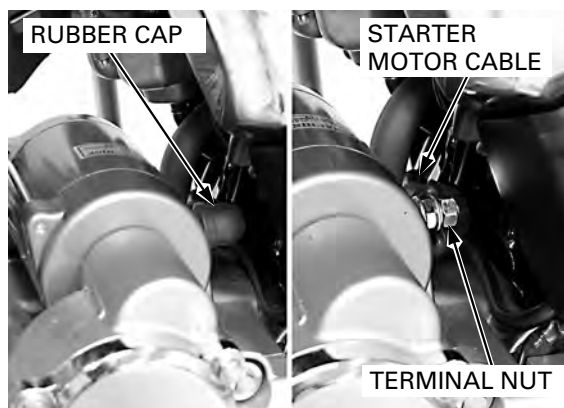

Remove the two mounting bolts, ground cable and the starter motor from the crankcase.

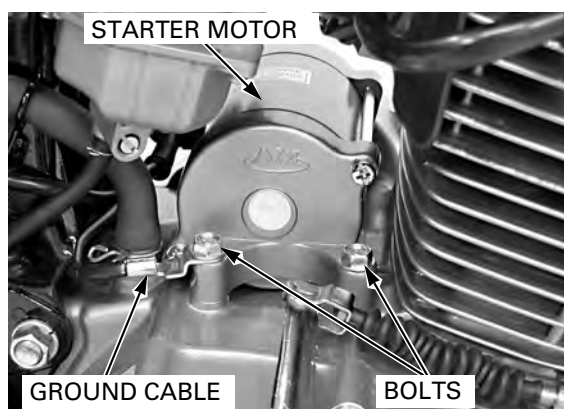

Remove the O-ring from the starter motor.



DISASSEMBLY/INSPECTION

Remove the starter motor case screws.



ELECTRIC STARTER

Record the location and number of shims. The number of the shims are different individually.

Remove the following:

- Rear cover
- Seal ring
- Shim(s)

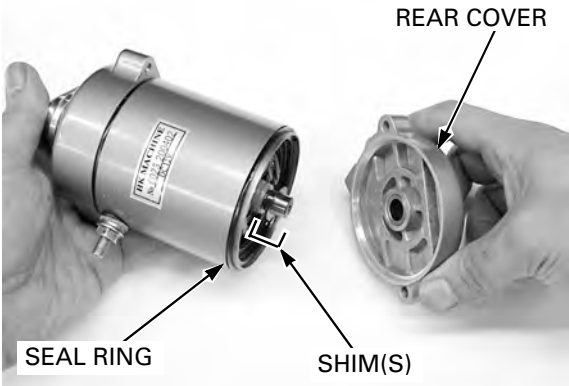

Record the location and number of shims. The number of the shims are different individually.

Remove the following:

- Front cover
- Seal ring
- Shim(s)

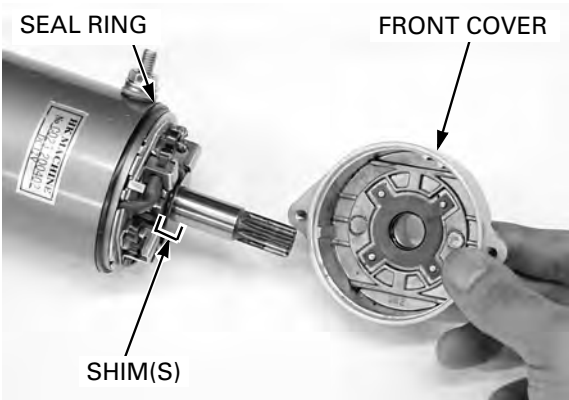

Remove the armature from the starter motor case.

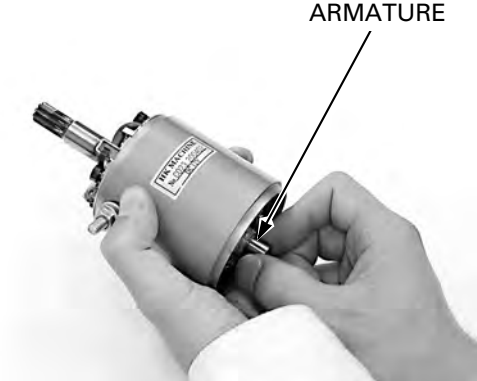

Check the bushing in the rear cover for wear or damage.

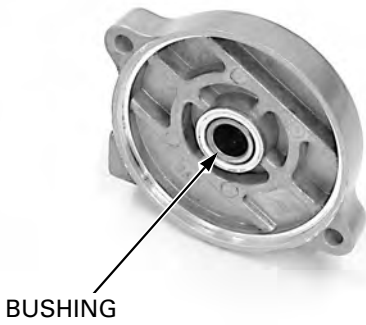

ELECTRIC STARTER

Check the oil seal and bushing in the front cover for deterioration, wear or damage.

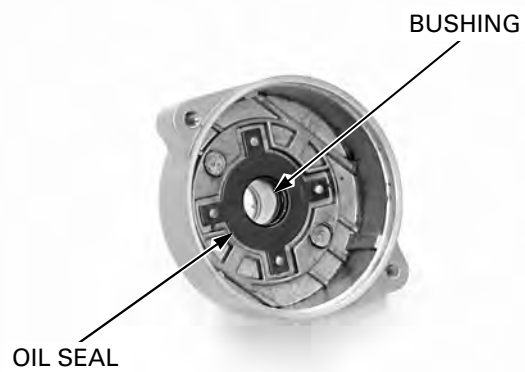

Do not use emery or sand paper on the commutator.

Check the commutator bars of the armature for discoloration.

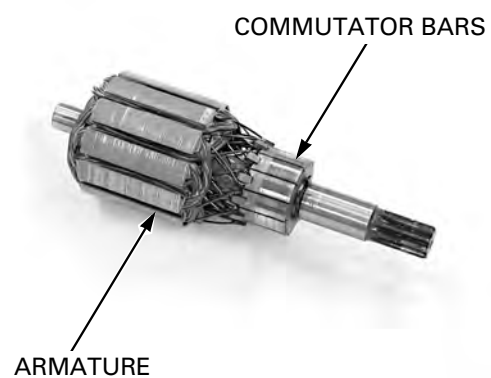

Check for continuity between pairs of commutator bars. There should be continuity.



Check for continuity between each commutator bar and the armature shaft. There should be no continuity.

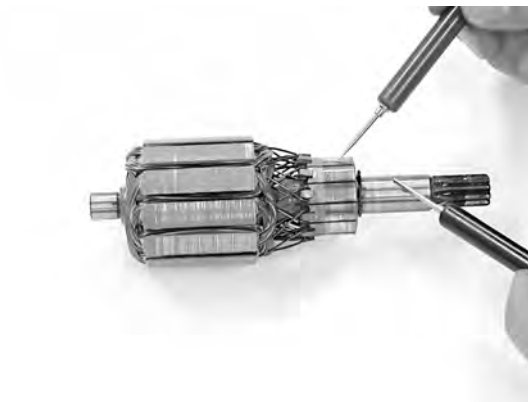

ELECTRIC STARTER

Check for continuity between the insulated brush and cable terminal as shown. There should be continuity.

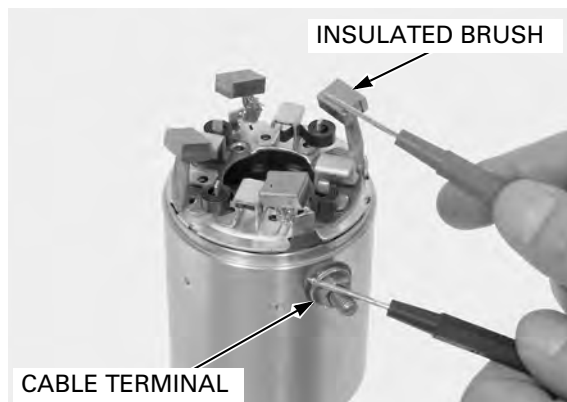

Check for continuity between the insulated brush and motor case as shown. There should be no continuity.

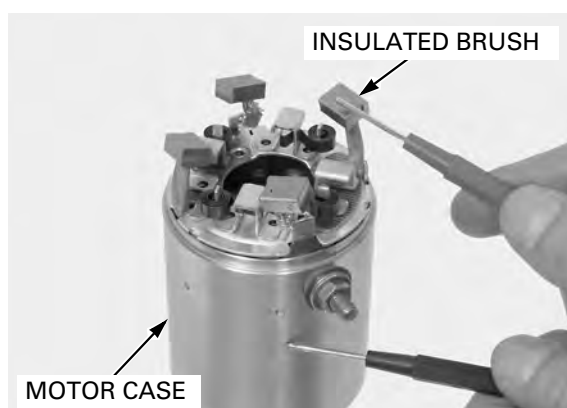

Check for continuity between the (+) and (-) terminals of the brush holder. There should be no continuity.

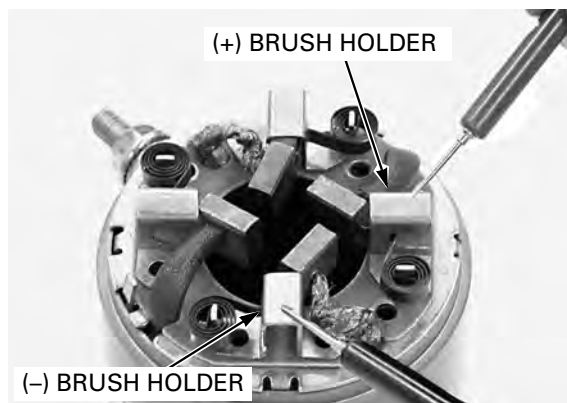

Remove the following:

- Nut
- Washer
- Insulators

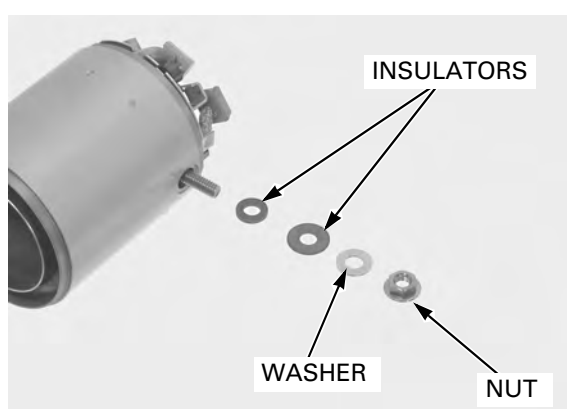

ELECTRIC STARTER

Remove the brush holder assembly from the starter motor case.

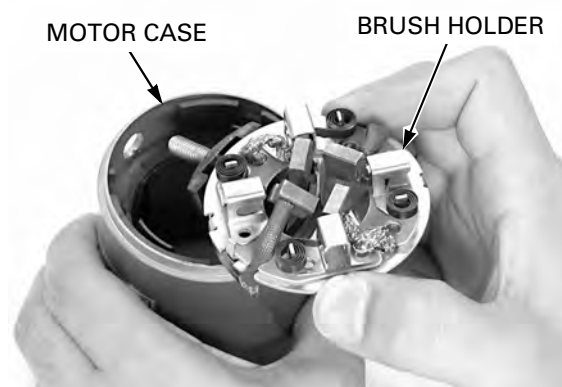

Remove the insulated brush/cable terminal from the brush holder.

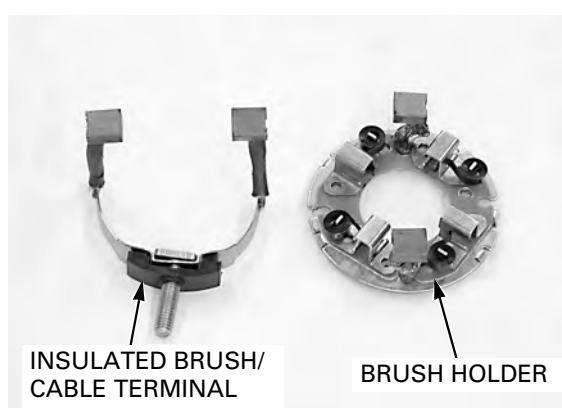

Inspect the brush for wear or damage and measure the brush length.

SERVICE LIMIT: 6.5 mm (0.26 in)



ASSEMBLY

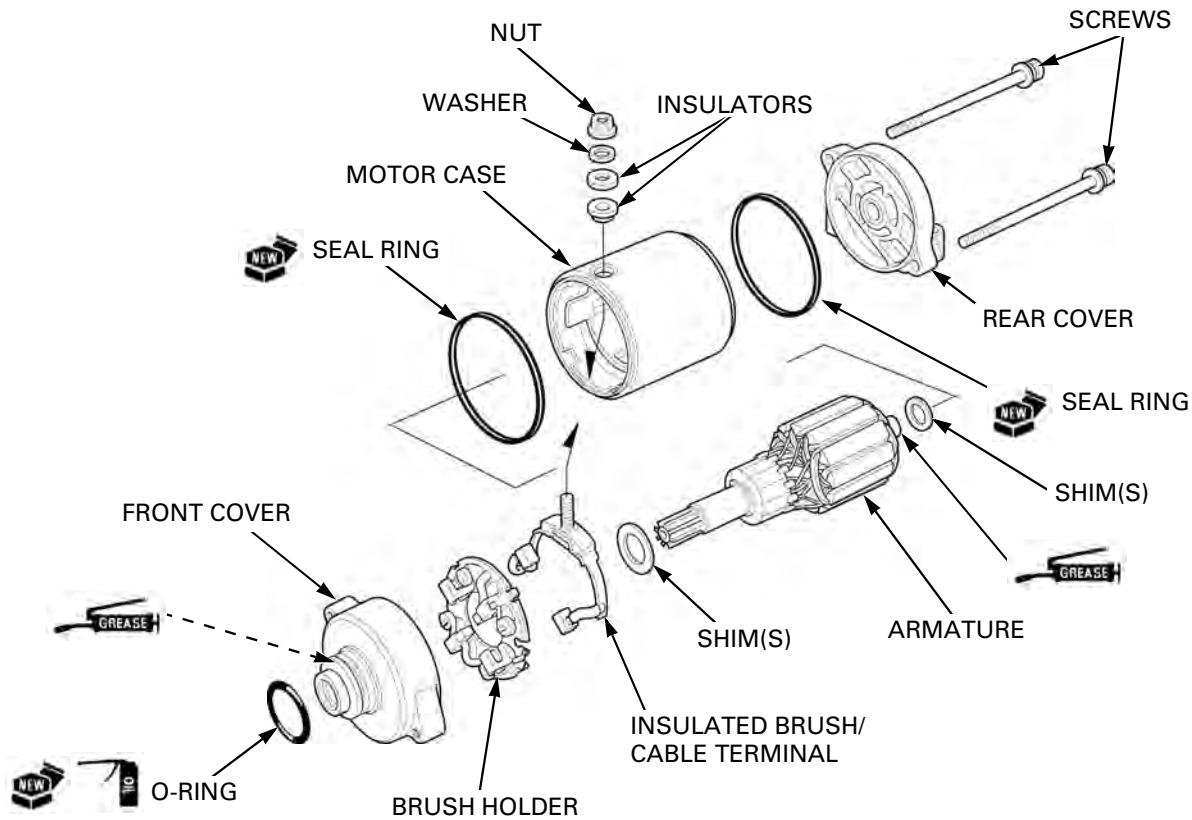

Install the insulated brush/cable terminal into the brush holder.

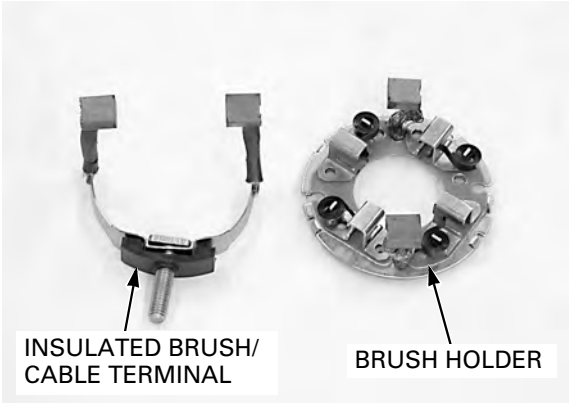

Install the brush holder assembly into the starter motor case by aligning the terminal with the hole of the motor case.

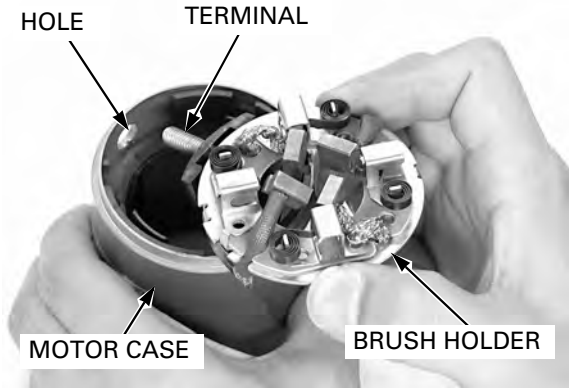

ELECTRIC STARTER

Align the holder tab with the motor case groove.

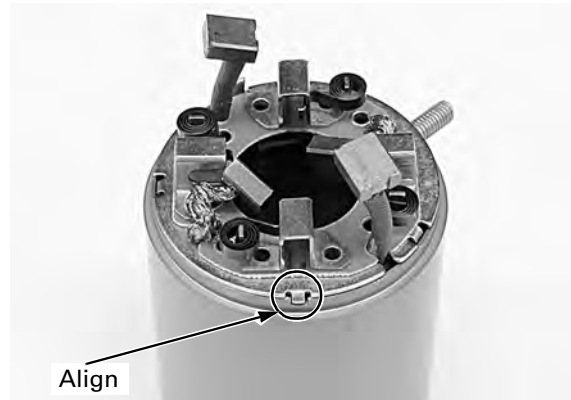

Install the following:

- Insulators
- Washer
- Nut

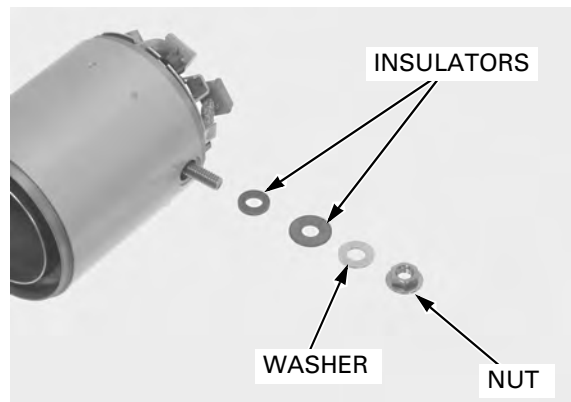

Install the armature in the motor case.
When installing the armature into the motor case, insert the brushes into the brush holder and hold them, hold the armature tightly to keep the magnet of the case from pulling the armature.

NOTICE

The coil may be damaged if the magnet pulls the armature and hits the case.

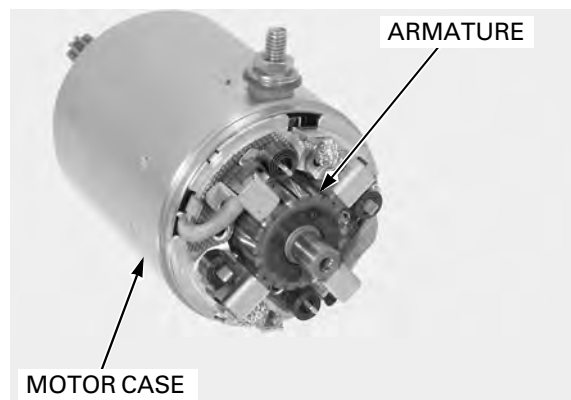

Install the shims properly as noted during removal.

Install the shim(s) onto the armature shaft.
Install a new seal ring onto the motor case.
Apply grease to the oil seal lip and bushing in the front cover.

Install the front cover by aligning the tab on the brush holder with the groove of the cover.

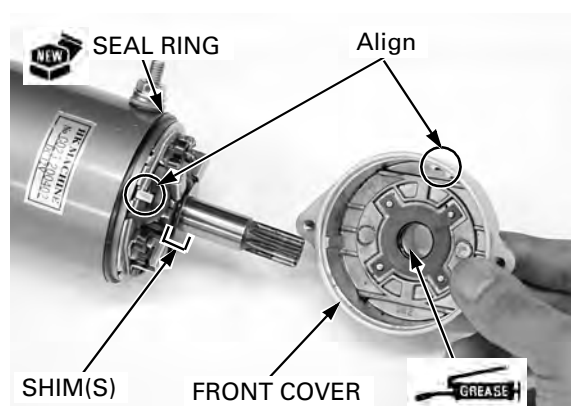

ELECTRIC STARTER

Install the shims properly as noted during removal.

Install the shim(s) onto the armature shaft.
 Install a new seal ring onto the motor case.
 Apply thin coat of grease to the armature shaft end.
 Install the rear cover.

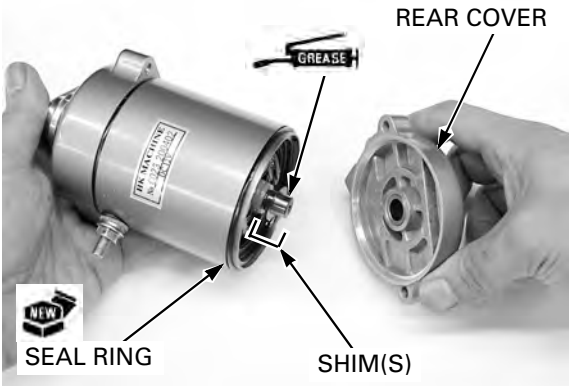

Install the motor case screws and tighten them.

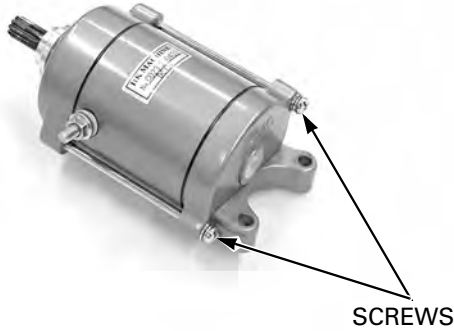

INSTALLATION

Coat a new O-ring with clean engine oil and install it into the starter motor groove.



Install the starter motor into the left crankcase cover and onto the crankcase.
 Install the mounting bolts with the ground cable, and tighten the bolts.

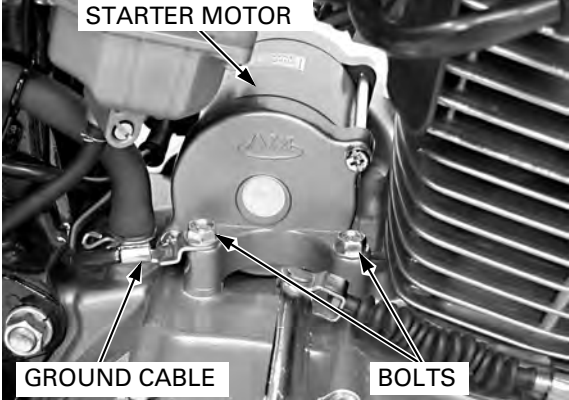

ELECTRIC STARTER

Install the starter motor cable and terminal nut onto the motor terminal and tighten the nut. Install the rubber cap over the motor terminal properly.

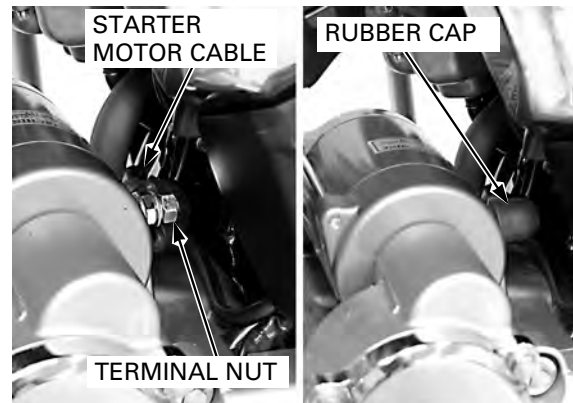

STARTER RELAY SWITCH

OPERATION INSPECTION

Remove the left side cover (page 2-3).

Shift the transmission into neutral. Turn the ignition switch to "ON" and push the starter switch. The coil is normal if the starter relay switch clicks.

If you don't hear the switch click, inspect the relay switch circuits (page 17-14).

If you hear the switch click, but starter motor does not turn, inspect the relay switch (page 17-15).



CIRCUIT INSPECTION

GROUND LINE

Turn the ignition switch to "OFF".

Disconnect the starter relay switch 2P connector.

Check for continuity between the Green/Red wire terminal of the wire harness side connector and ground.

If there is continuity when the transmission is in neutral or when the clutch lever is squeezed, the ground circuit is normal.



POWER INPUT LINE

Disconnect the starter relay switch 2P connector.

Turn the ignition switch to "ON".

Measure the voltage between the Yellow/Red wire terminal (+) and ground (-).

If the battery voltage appears only when the starter switch is pushed, the circuit is normal.



ELECTRIC STARTER

FUNCTION INSPECTION

Remove the starter relay switch (page 17-15).

Connect an ohmmeter to the starter relay switch cable terminals.

Connect the fully charged 12 V battery positive terminal to the Yellow/Red wire terminal and negative terminal to the Green/Red wire terminal of the starter relay switch.

There should be continuity between the cable terminals while the battery is connected, and no continuity when the battery is disconnected.

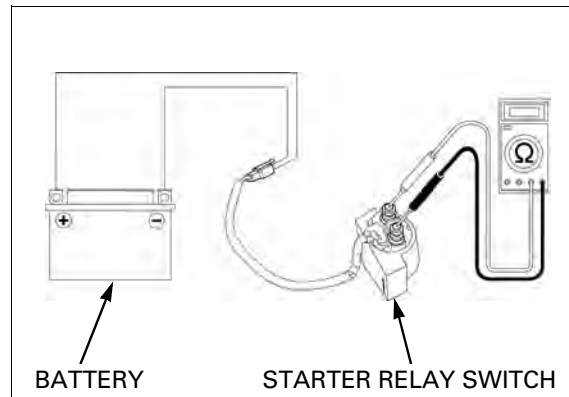

REMOVAL/INSTALLATION

Remove the left side cover (page 2-3).

Disconnect the battery negative (-) cable from the battery (page 15-6).

Disconnect the starter relay switch 2P connector.

Turn over the rubber covers.

Remove the nuts, battery cable and starter motor cable from the starter relay switch.

Remove the starter relay switch from the stays of the frame.

Installation is in the reverse order of removal.

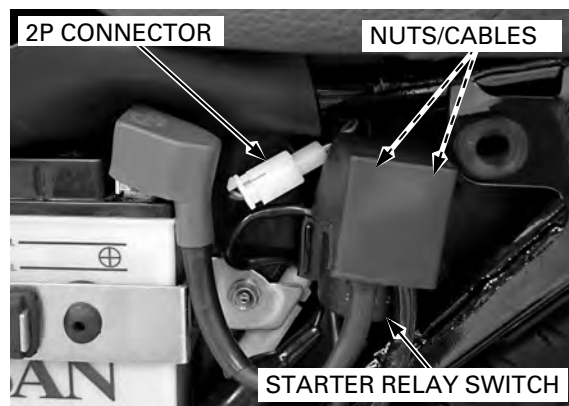

NEUTRAL DIODE

INSPECTION

Remove the fuel tank (page 2-4).

Remove the neutral diode.

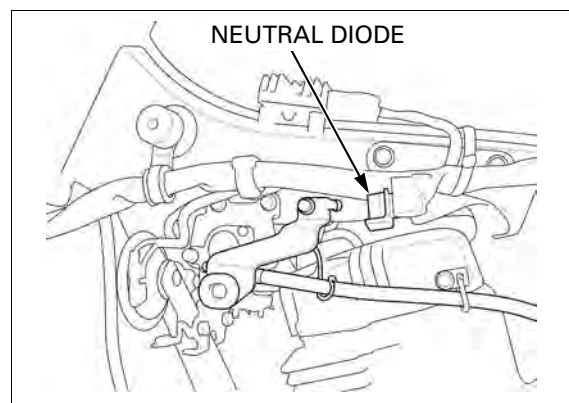

Check for continuity between the diode terminals. When there is continuity, a small resistance value will register.

If there is continuity in one direction, the neutral diode is normal.

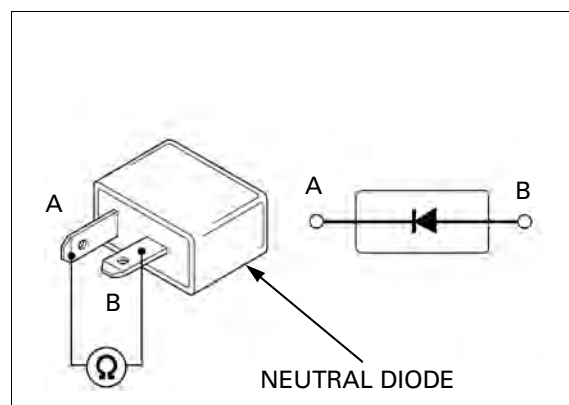

MEMO

18. LIGHTS/METER/SWITCHES

COMPONENT LOCATION	18-2	IGNITION SWITCH	18-9
SERVICE INFORMATION	18-3	HANDLEBAR SWITCHES	18-10
HEADLIGHT	18-4	BRAKE LIGHT SWITCHES	18-11
POSITION LIGHT	18-4	CLUTCH SWITCH	18-12
BRAKE/TAIL LIGHT	18-4	GEAR POSITION SWITCH	18-12
TURN SIGNAL LIGHT	18-5	FUEL LEVEL SENSOR	18-14
COMBINATION METER	18-6	HORN	18-15
TACHOMETER	18-8	TURN SIGNAL RELAY	18-16

LIGHTS/METER/SWITCHES
COMPONENT LOCATION

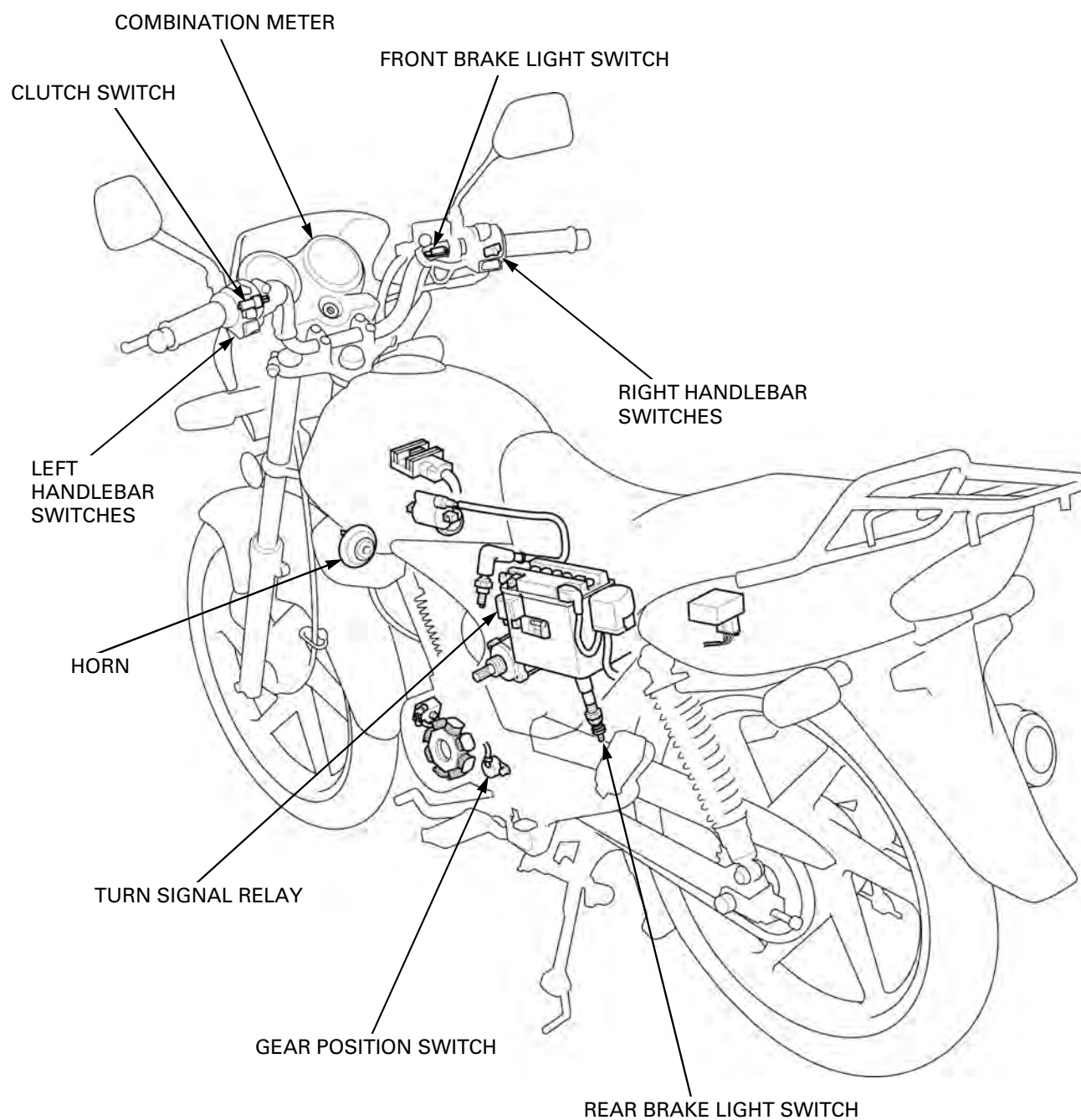

SERVICE INFORMATION

GENERAL

- Check the battery condition before performing any inspection that requires proper battery voltage.
- A continuity test can be made with the switches installed on the motorcycle.
- The following color codes are used throughout this section.

Bu = Blue	G = Green	Lg = Light Green	R = Red
Bl = Black	Gr = Gray	O = Orange	W = White
Br = Brown	Lb = Light Blue	P = Pink	Y = Yellow

SPECIFICATIONS

ITEM		SPECIFICATION
Bulbs	Headlight (Hi/low beam)	12 V - 35/35 W
	Brake/tail light	12 V - 21/5 W
	Turn signal light	12 V - 10 W x 4
	Position light	12 V - 4W
	Instrument light	12 V - 1.7 W x 4
	Turn signal indicator	12 V - 3.4 W x 2
	High-beam indicator	12 V - 3.4 W
	Neutral indicator	12 V - 3.4 W
Fuse		15 A
Fuel level sensor resistance (20°C/68°F)	Full	4 - 10 Ω
	Empty	97.5 - 107.5 Ω

TORQUE VALUES

Ignition switch mounting bolt 24 N·m (2.4 kgf·m, 18 lbf·ft)

TOOL

Peak voltage adaptor
07HGJ-0020100

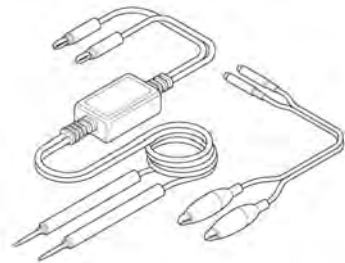

with commercially available digital multimeter (impedance 10 MΩ/DCV minimum)
or Imrie diagnostic tester (model 625)

LIGHTS/METER/SWITCHES

HEADLIGHT

BULB REPLACEMENT

Remove the front cowl (page 2-7).

Pull back the dust cover.

Turn the headlight bulb socket counterclockwise and remove it from the headlight unit.

Push the headlight bulb in, turn it counterclockwise and remove it.

Replace the bulb with a new one.

Installation is in the reverse order of removal.

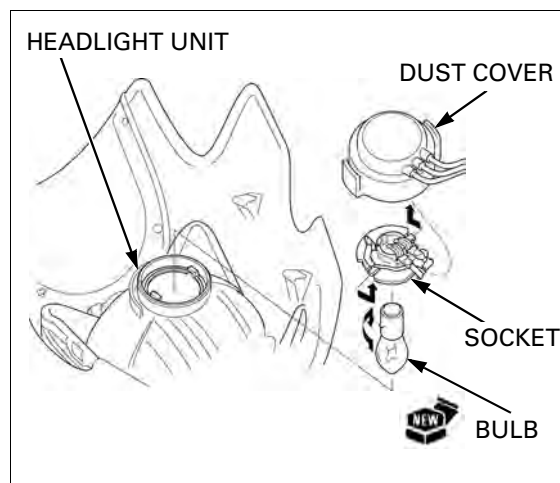

POSITION LIGHT

BULB REPLACEMENT

Pull out the position light bulb socket from the headlight unit.

Push the position light bulb in, turn it counterclockwise and remove it.

Replace the bulb with a new one.

Installation is in the reverse order of removal.

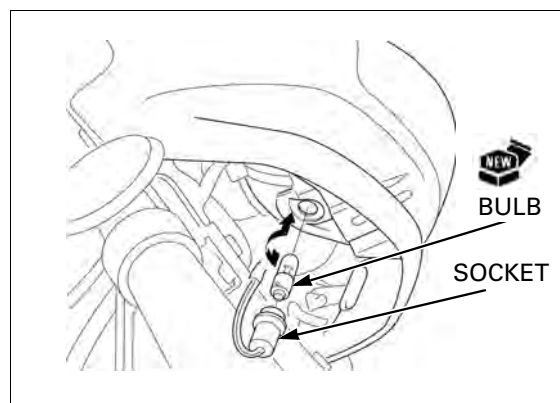

BRAKE/TAIL LIGHT

BULB REPLACEMENT

Remove the screws and the brake/tail light lens.

Push the bulb in, turn it counterclockwise and remove it.

Replace the bulb with a new one.

Installation is in the reverse order of removal.

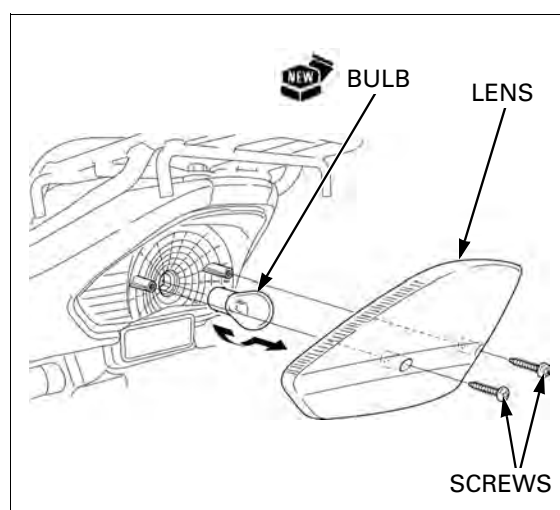

REMOVAL/INSTALLATION

Remove the rear cowl (page 2-5).

Release the brake/tail light wire from the clamp under the rear carrier stay and disconnect the brake/tail light 3P connector.

Remove two brake/tail light unit mounting bolts and washers.

Release the boss of the tail light unit from the grommet of the rear fender and remove the brake/tail light unit, collars and grommets.

Installation is in the reverse order of removal.

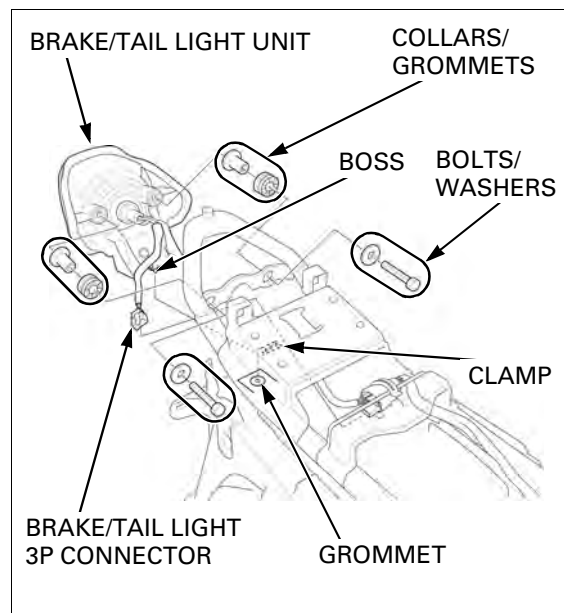

TURN SIGNAL LIGHT

BULB REPLACEMENT

Remove the lower screw and the turn signal light reflector/lens from the turn signal base.

Remove two screws and turn signal lens from the reflector.

Push the bulb in, turn it counterclockwise and remove it.

Replace the bulb with a new one.

Installation is in the reverse order of removal.

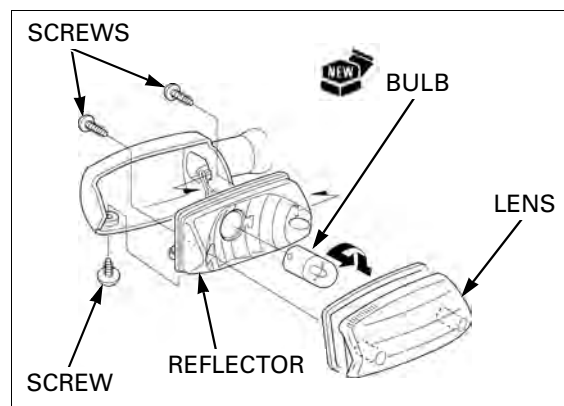

LIGHTS/METER/SWITCHES

COMBINATION METER

BULB REPLACEMENT

Remove the following:

- Combination meter (page 18-6)
- Combination meter mounting bracket (page 18-7)

Pull out the combination meter light bulb sockets.

Replace the bulbs with new ones.

Installation is in the reverse order of removal.

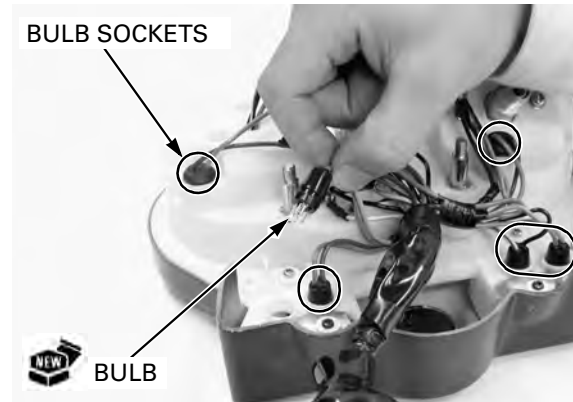

REMOVAL/INSTALLATION

Remove the front cowl (page 2-7).

Release the combination meter connector dust cover from the clamps.

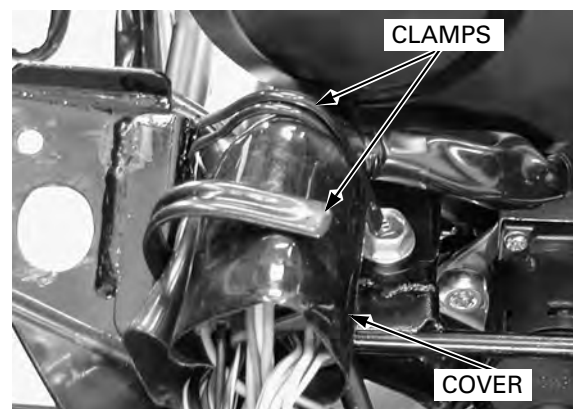

Disconnect the gear position indicator 6P Brown connector, combination meter 6P Black connector and combination meter Black/Yellow, Black, Light blue and Green wire connectors.

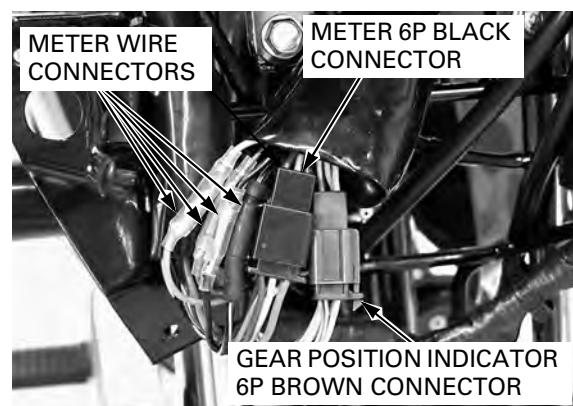

Disconnect the speedometer cable.

Remove two combination meter bolts and the combination meter.

Installation is in the reverse order of removal.

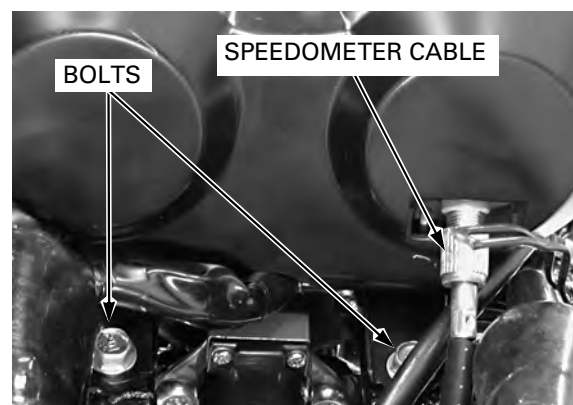

DISASSEMBLY/ASSEMBLY

Remove the combination meter (page 18-6).
 Remove three screws and the combination meter lower cover.

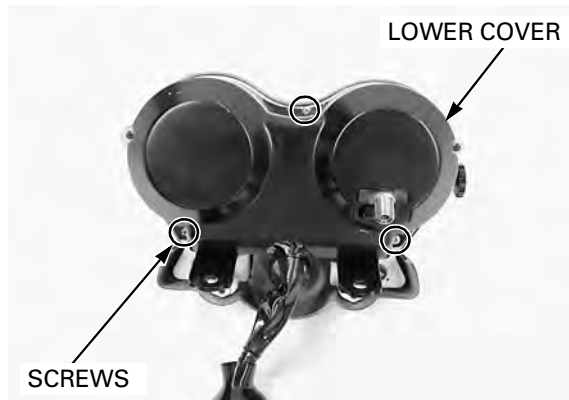

Remove three nuts/washers and the combination meter mounting bracket.

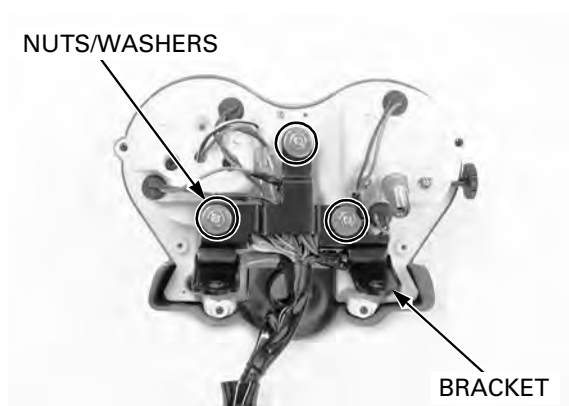

Pull out the combination meter light bulb sockets.
 Remove three fuel unit terminal screws and disconnect the fuel unit terminals.

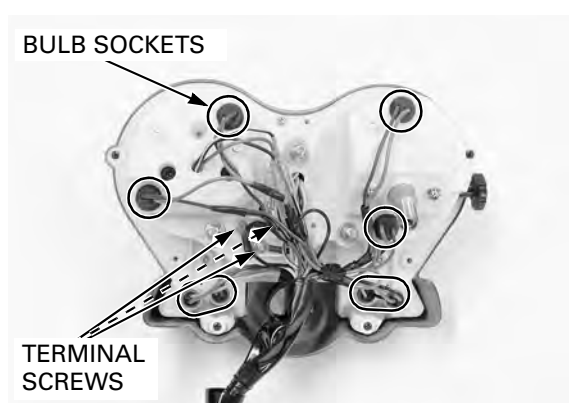

Remove seven screws and the combination meter upper case from the combination meter unit.

Do not touch the speedometer and tachometer panel surfaces.

Remove two speedometer mounting screws and the speedometer unit from the combination meter case.
 Remove two tachometer mounting screws, washers and the tachometer unit from the combination meter case.

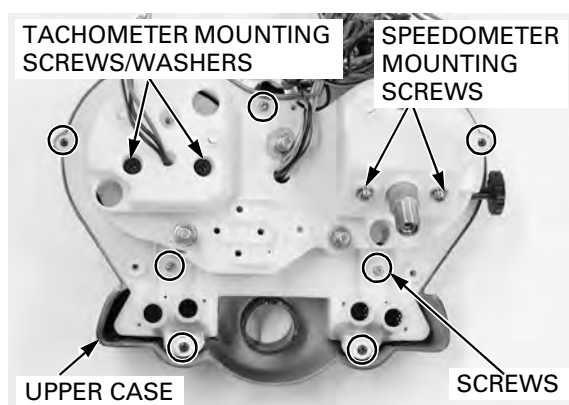

LIGHTS/METER/SWITCHES

Assembly is in the reverse order of disassembly.

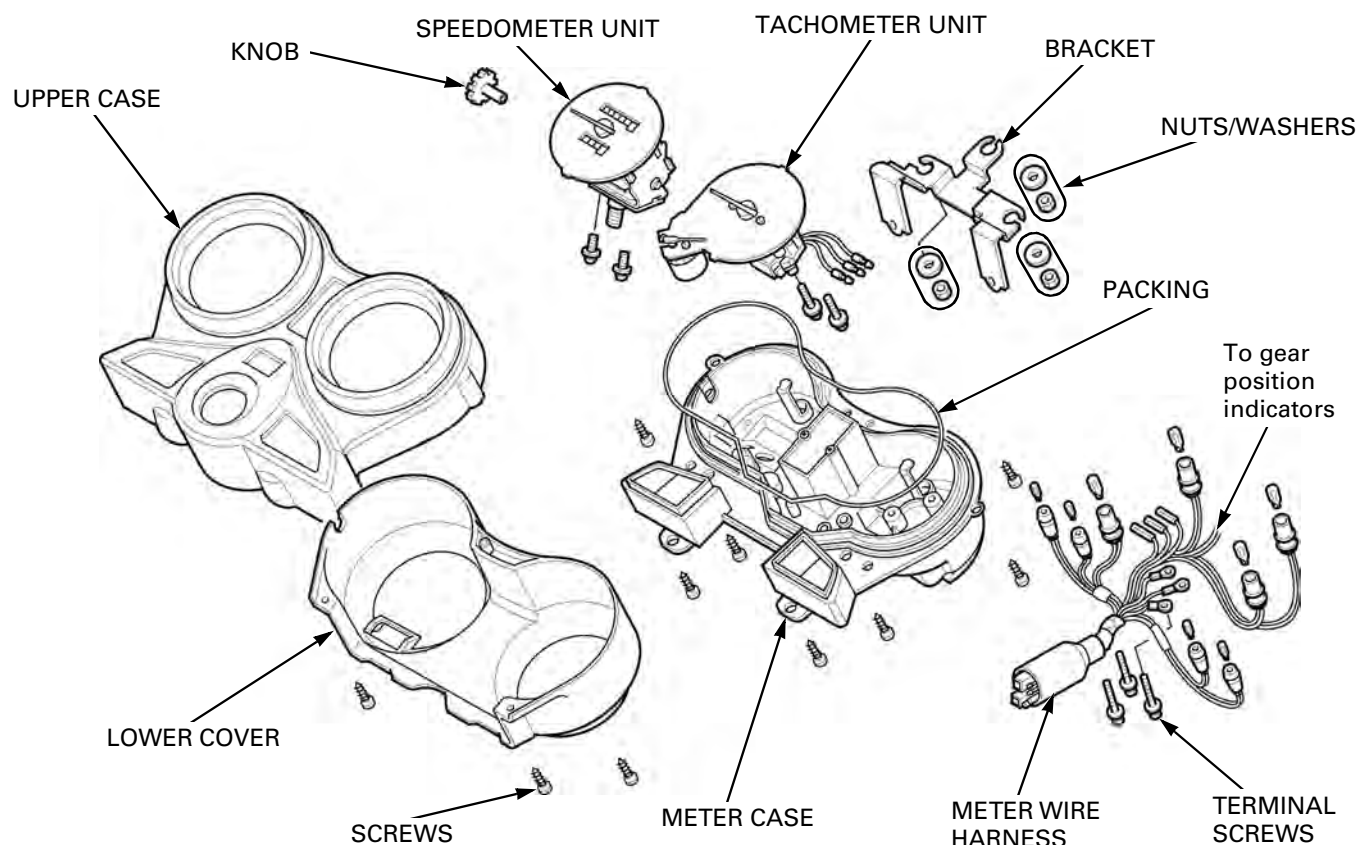

TACHOMETER

GROUND LINE INSPECTION

Remove the front cowl (page 2-7).

Disconnect the green wire connector.

Check for continuity between the Green wire terminal of the meter side and body ground.

There should be continuity.

If there is no continuity, check for open circuit in the Green wire.

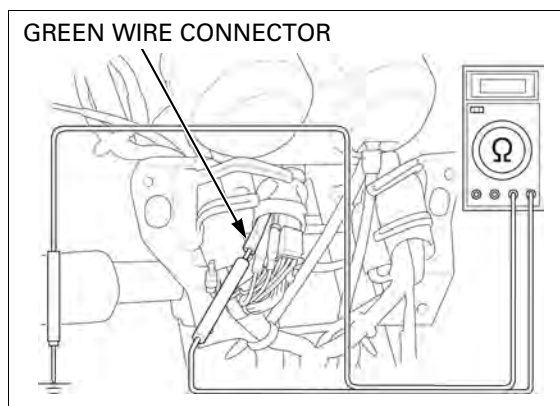

POWER VOLTAGE LINE INSPECTION

Turn the ignition switch "ON" and measure the voltage between the Black (+) and Green (-) wire terminals.

There should be battery voltage.

If there is no battery voltage, check for open circuit in the Black and/or Green wire.

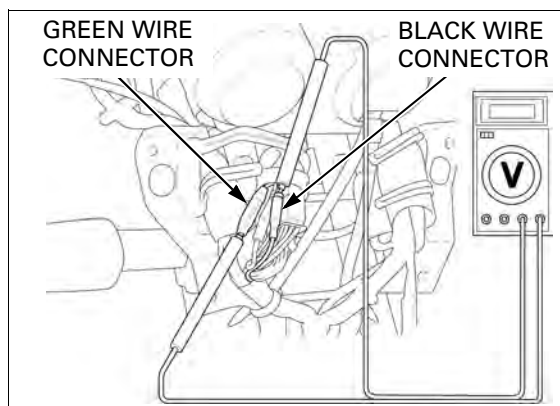

INPUT LINE INSPECTION

Connect the peak voltage adaptor to the tachometer Black/Yellow (+) and Green (-) wire terminals.

- Use a commercially available digital multimeter with an impedance of 10 MΩ/DCV minimum.
- The display value differs depending upon the internal impedance of the multimeter.
- If using the Imrie diagnostic tester (model 625), follow the manufacturer’s instructions.

TOOL:

**Imrie diagnostic tester (model 625) or
Peak voltage adaptor 07HGJ-0020100
with commercially available digital multimeter
(impedance 10 MΩ/DCV minimum)**

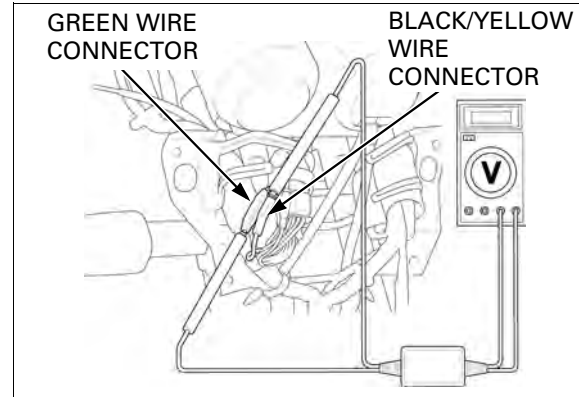

Start the engine and measure tachometer input peak voltage.

PEAK VOLTAGE: 10.5 V minimum

- If the value is normal, replace the tachometer (page 18-6).
- If the measured value is below 10.5 V, check the ignition control module (ICM) (page 16-10).
- If the value is 0 V, check for continuity between the combination meter wire terminal and the ICM 4P connector Black/Yellow terminals.

Install the front cowl (page 2-7).

IGNITION SWITCH

INSPECTION

Remove the front cowl (page 2-7).

Disconnect the ignition switch 2P (White) connector and Black/White and Green wire connectors. Check for continuity at the terminals in each switch position according to the table.

IGNITION SWITCH

	IG	E	BAT1	BAT2
OFF	○—○			
ON			○—○	
COLOR	BI/W	G	R	BI

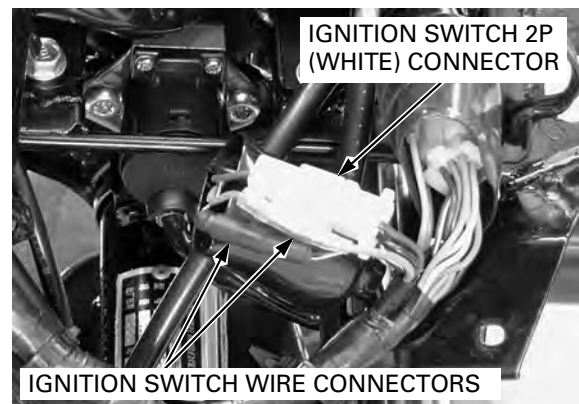

REMOVAL/INSTALLATION

Remove the top bridge (page 12-31).

Remove the ignition switch mounting bolts and the ignition switch.

Install the ignition switch in the reverse order of removal.

TORQUES:

**Ignition switch mounting bolts:
24 N·m (2.4 kgf·m, 18 lbf·ft)**

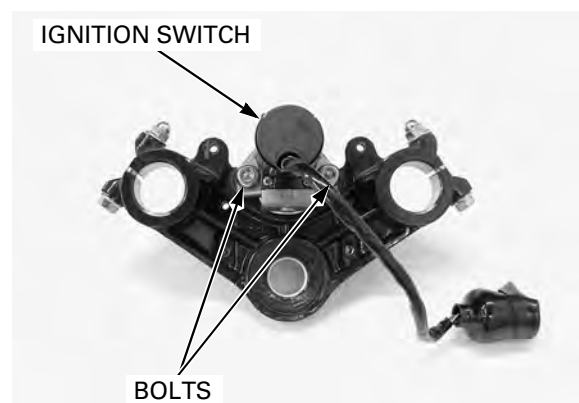

LIGHTS/METER/SWITCHES

HANDLEBAR SWITCHES

RIGHT HANDLEBAR SWITCH

Remove the front cowl (page 2-7).

Disconnect the right handlebar switch 6P (White) connector.

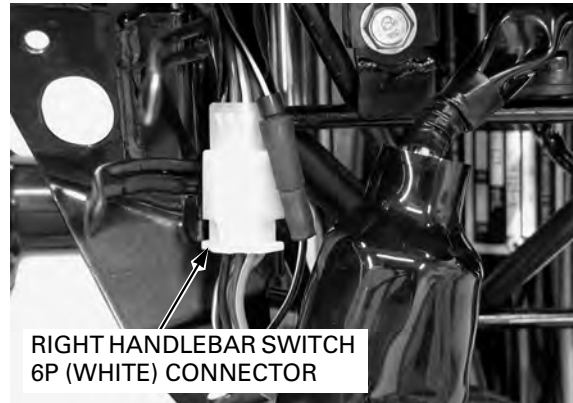

Check for continuity between the terminals in each switch position according to the table.

STARTER SWITCH

	ST	BAT
FREE		
PUSH	○	○
COLOR	Y/R	BI

ENGINE STOP SWITCH

	E	IG
⊘		
⊗	○	○
COLOR	G	BI/W

LIGHTING SWITCH

	BAT	TL	HL
●			
☺	○	○	
☼	○	○	○
COLOR	BI	Br	Bu/W

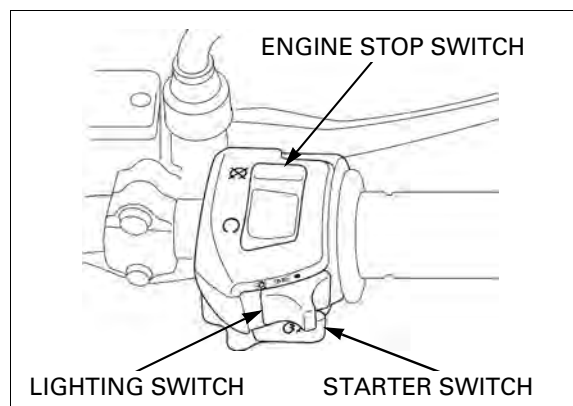

LEFT HANDLEBAR SWITCH

Remove the front cowl (page 2-7).

Disconnect the left handlebar switch 9P (White) connector.

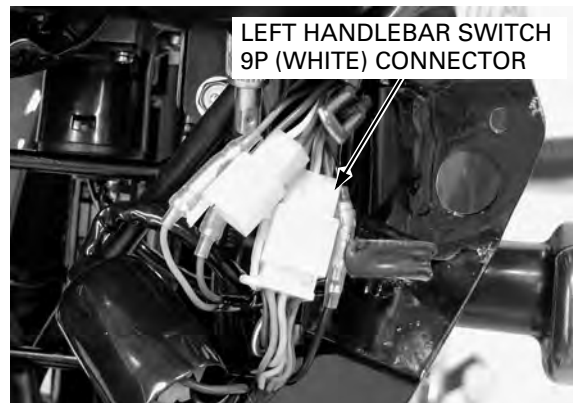

Check for continuity between the terminals in each switch position according to the table.

DIMMER SWITCH

	HL	HI	LO
☺	○		○
(N)	○	○	○
☼	○	○	
COLOR	Bu/W	Bu	W

TURN SIGNAL SWITCH

	R	WR	L
→	○	○	
N			
←			○
COLOR	Lb	Gr	O

HORN SWITCH

	BAT	HO
FREE		
PUSH	○	○
COLOR	BI	Lg

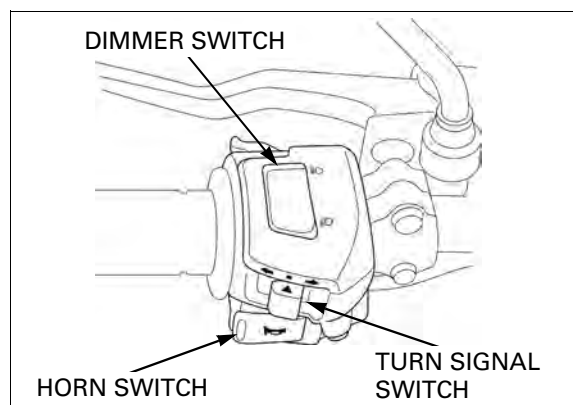

BRAKE LIGHT SWITCHES

FRONT

Disconnect the front brake light switch connectors.

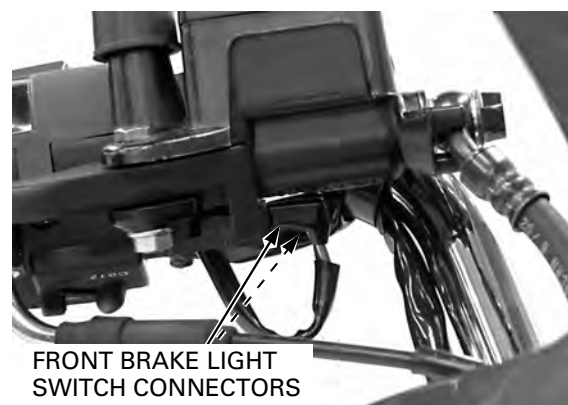

Check the continuity between the switch connectors.

There should be continuity with the brake lever applied, and there should be no continuity when the brake lever is released.

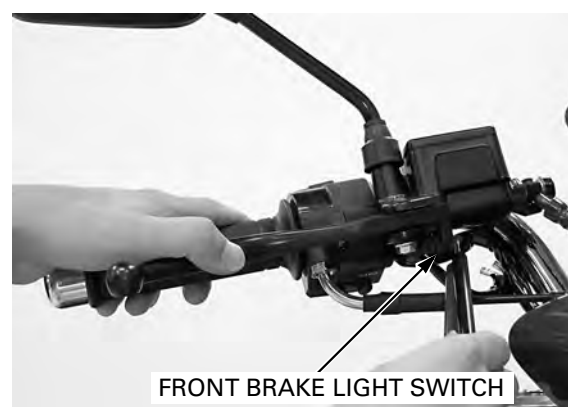

REAR

Remove the right side cover (page 2-3).

Disconnect the rear brake light switch 2P connector and check for continuity between the terminals.

There should be continuity with the brake pedal applied, and there should be no continuity when the brake pedal is released.



LIGHTS/METER/SWITCHES

CLUTCH SWITCH

INSPECTION

Disconnect the clutch switch connectors.

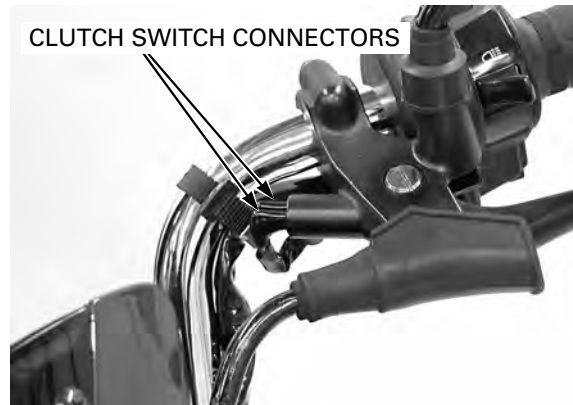

There should be continuity with the clutch lever applied, and there should be no continuity when the clutch lever is released.



GEAR POSITION SWITCH

INSPECTION

Remove the left side cover (page 2-3).

Disconnect the gear position switch 6P connector.

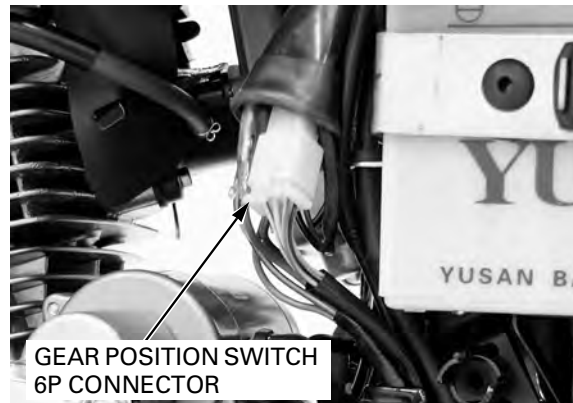

Check for continuity between the terminals at each gear position.

GEAR POSITION SWITCH

GEAR	GROUND	Lg/R	Lg/P	Lg/Br	Lg/G	Lg/Y	Lg/Bl
N	○	○					
1	○		○				
2	○			○			
3	○				○		
4	○					○	
5	○						○

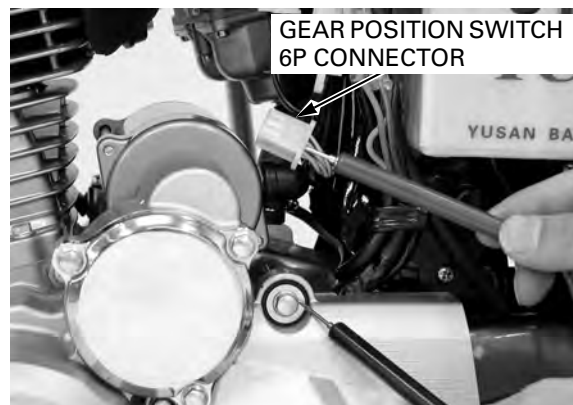

REMOVAL

Remove the left crankcase rear cover (page 6-4).
Disconnect the gear position switch 6P connector (page 18-12).

Remove the bolt and the alternator/gear position switch wire guide plate.

Release the gear position switch wire from the clamp.

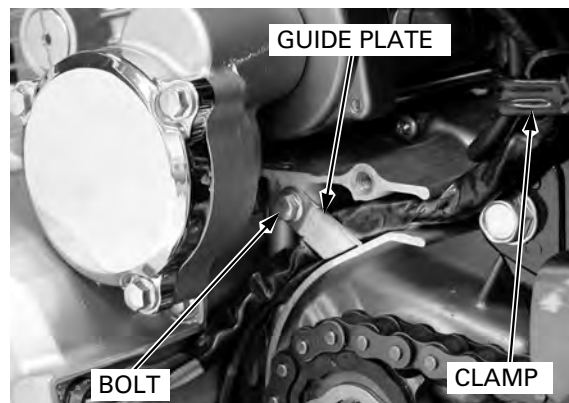

Remove the gear position switch mounting bolt and the gear position switch.

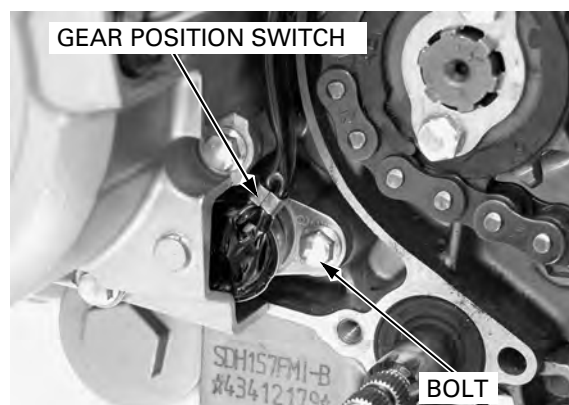

Check the condition of the spring pin.



INSTALLATION

Install the gear position switch while aligning the spring pin with the slot of the shift drum.

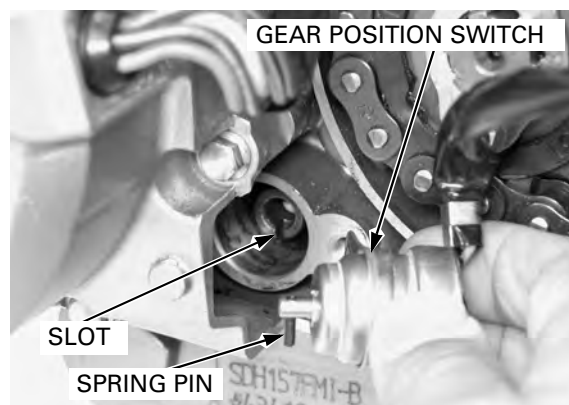

LIGHTS/METER/SWITCHES

Install and tighten the gear position switch mounting bolt.



Set the gear position switch wire to the clamp and route it in the left crankcase cover groove properly.

Install the alternator/gear position switch wire guide plate and tighten the bolt.

Connect the gear position switch 6P connector. Install the left crankcase rear cover (page 6-5).

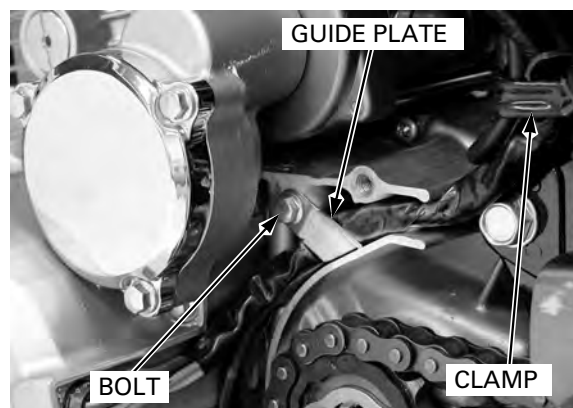

FUEL LEVEL SENSOR

INSPECTION

Remove the fuel level sensor (page 18-14).

Connect the ohmmeter to the fuel level sensor terminals.

Inspect the resistance of the float at the top and bottom positions.

	FULL	EMPTY
Resistance (20°C/68°F)	4 – 10 Ω	97.5 – 107.5 Ω

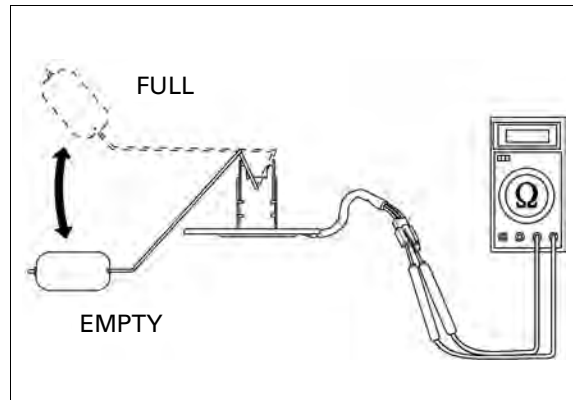

REMOVAL/INSTALLATION

Remove the fuel tank (page 2-4).

Release the fuel level sensor wire from the wire clamp.

Remove four nuts and fuel level sensor unit.

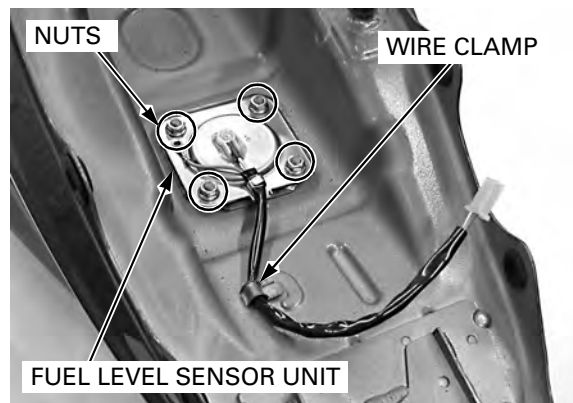

LIGHTS/METER/SWITCHES

Install a new O-ring to the fuel level sensor unit.
Be careful not to damage the float arm.
Install the fuel level sensor unit into the fuel tank.

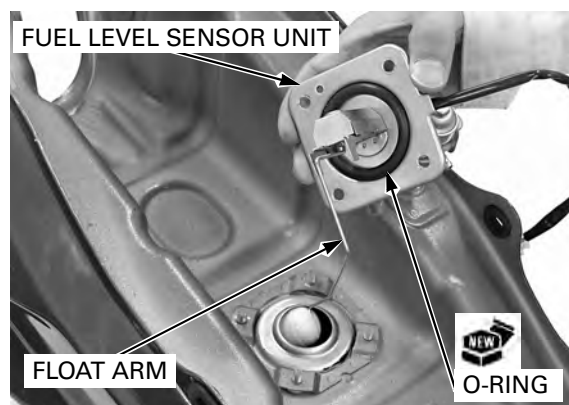

Install the nuts and tighten them in crisscross pattern.
Connect the fuel level sensor wire to the wire clamp.
Install the fuel tank (page 2-4).

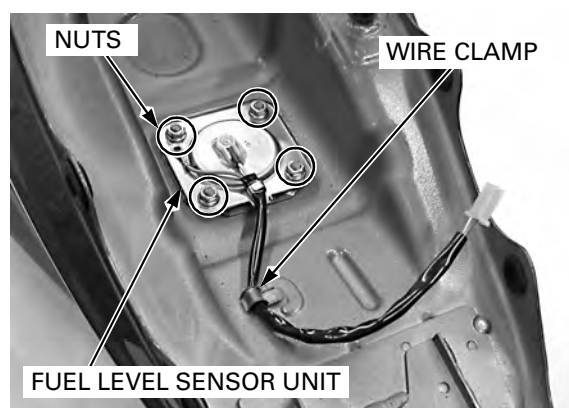

HORN

INSPECTION

Remove the right and left horn covers (page 2-7).
Disconnect the wire connectors from the horn.
Connect the battery voltage to the horn terminals.
The horn is normal if it sounds when the battery voltage is connected across the horn terminals.

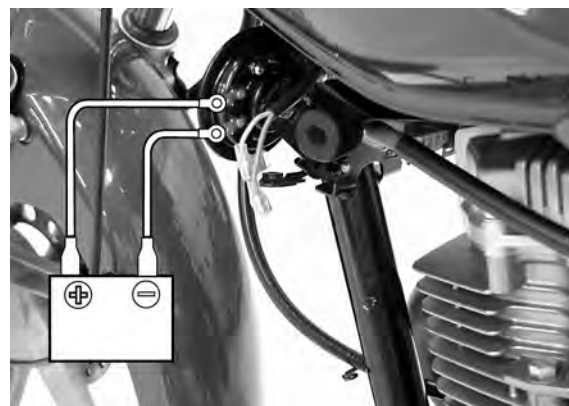

LIGHTS/METER/SWITCHES

TURN SIGNAL RELAY

INSPECTION

1. Recommended Inspection

Check the following

- Battery condition
- Burned out bulb or non-specified wattage
- Burned fuse
- Ignition switch and turn signal switch function
- Loose connector

Are the above items in good condition?

NO - Replace or repair the malfunction part(s)

YES - GO TO STEP 2.

2. Turn Signal Circuit Inspection

Remove the left side cover (page 2-3).

Disconnect the turn signal relay 2P connector from the relay.

Short the turn signal relay connector with a jumper wire. Turn the ignition switch on and check the turn signal light by turning the switch "ON".

Does the light come on?

YES - • Faulty turn signal relay
• Poor connection of the connector.

NO - Open or short circuit in wire harness

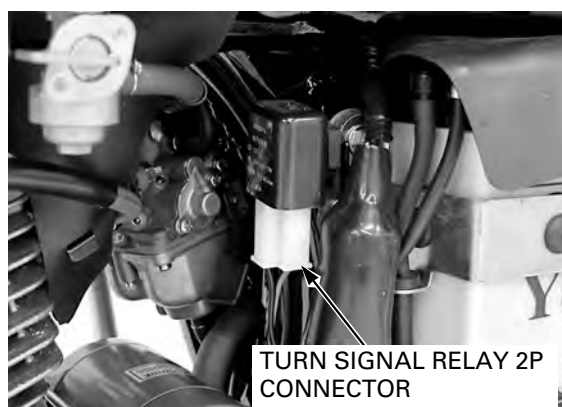

REMOVAL/INSTALLATION

Remove the left side cover (page 2-3).

Disconnect the turn signal relay 2P connector and remove the turn signal relay from the stay.

Installation is in the reverse order of removal.

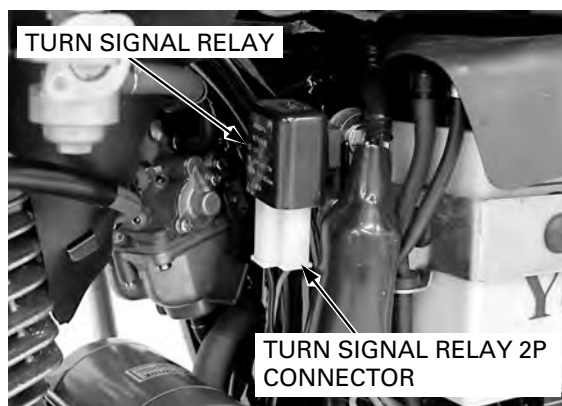

19. WIRING DIAGRAM

WIRING DIAGRAM 19-2

WIRING DIAGRAM

WIRING DIAGRAM

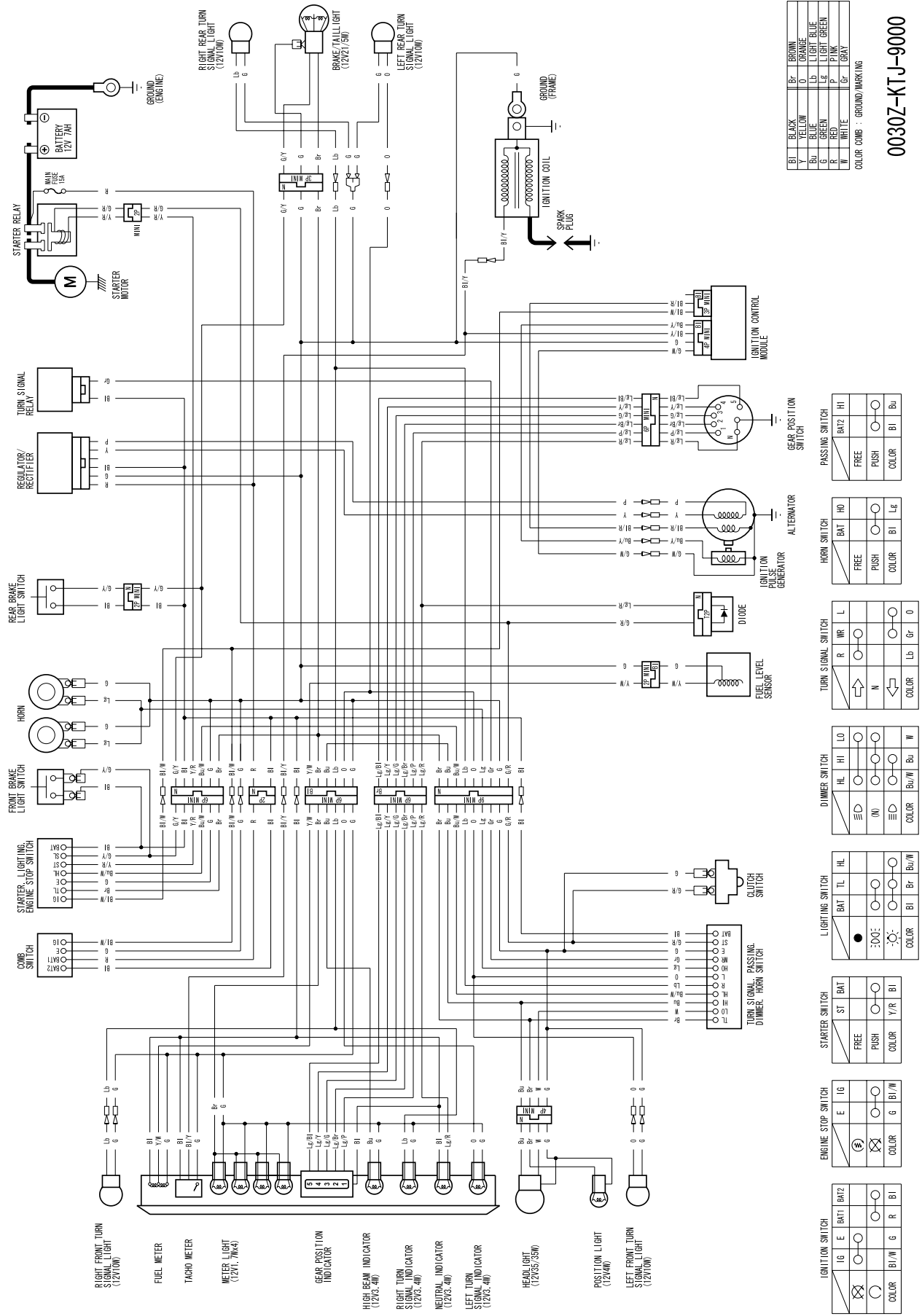

20. TROUBLESHOOTING

ENGINE DOES NOT START OR IS HARD TO START	20-2	POOR PERFORMANCE AT LOW AND IDLE SPEED	20-5
ENGINE LACKS POWER	20-3	POOR PERFORMANCE AT HIGH SPEED	20-6
		POOR HANDLING.....	20-6

TROUBLESHOOTING

ENGINE DOES NOT START OR IS HARD TO START

1. Fuel Line Inspection

Check fuel flow to the carburetor.

Does fuel reach the carburetor?

- NO** – • Clogged fuel hose or fuel strainer
• Clogged fuel valve
• Clogged fuel cap breather
• Sticking float valve

YES – GO TO STEP 2.

2. Spark Plug Inspection

Remove and inspect the spark plug.

Is the spark plug wet?

- YES** – • Flooded carburetor
• Throttle valve open
• Dirty air cleaner
• Improperly adjusted pilot screw

NO – GO TO STEP 3.

3. Spark Test

Perform spark test.

Is there weak or no spark?

- YES** – • Faulty spark plug
• Fouled spark plug
• Loose or disconnected ignition system wires
• Broken or shorted spark plug wire
• Broken or shorted ignition coil
• Faulty exciter coil
• Faulty igniting pulse generator
• Faulty ignition switch
• Faulty engine stop switch
• Faulty ignition control module (ICM)

NO – GO TO STEP 4.

4. Engine Starting Condition

Start engine by following normal procedure.

Does the engine start then stops?

- YES** – • Improper choke operation
• Incorrectly adjusted carburetor
• Leaking carburetor insulator
• Improper ignition timing (Faulty ICM or ignition pulse generator)
• Contaminated fuel

NO – GO TO STEP 5.

5. Cylinder Compression

Test cylinder compression.

Is the compression low?

- YES** – • Valve clearance too small
• Valve stuck open
• Worn cylinder and piston rings
• Damaged cylinder head gasket
• Seized valve
• Improper valve timing

ENGINE LACKS POWER**1. Drive Train Inspection**

Raise the rear wheel off the ground and spin it by hand.

Does the wheel spin freely?

- NO** – • Brake dragging
• Worn or damaged wheel bearings
• Bent axle
• Drive chain too tight

YES – GO TO STEP 2.

2. Tire Pressure Inspection

Check tire pressure.

Is the tire pressure low?

- YES** – • Faulty tire valve
• Punctured tire

NO – GO TO STEP 3.

3. Clutch Inspection

Accelerate rapidly from low to second.

Does the engine speed change accordingly when the clutch is engaged?

- NO** – • Clutch slipping
• Worn clutch discs/plates
• Warped clutch discs/plates
• Weak clutch spring
• Sticking clutch lifter
• Additive in engine oil

YES – GO TO STEP 4.

4. Engine Condition Inspection

Accelerate lightly.

Does the engine speed increase?

- NO** – • Fuel/air mixture too rich or lean
• Clogged air cleaner
• Restricted fuel flow
• Clogged muffler
• Clogged fuel cap breather
• Carburetor choke is on
• Excessive carbon build-up in combustion chamber

YES – GO TO STEP 5.

5. Engine Condition Inspection

Accelerate or run at high speed.

Is there knocking?

- YES** – • Worn piston and cylinder
• Use of poor quality fuel
• Excessive carbon build-up in combustion chamber
• Ignition timing too advanced (Faulty ICM)
• Lean fuel mixture

NO – GO TO STEP 6.

6. Ignition Timing Inspection

Check ignition timing.

Is the ignition timing correct?

- NO** – • Faulty ignition control module (ICM)
• Faulty ignition pulse generator

YES – GO TO STEP 7.

TROUBLESHOOTING

7. Engine Oil Inspection

Check the oil level and condition.

Is the oil level correct and the oil in good condition?

- NO** – • Oil level too high
• Oil level too low
• Contaminated oil

YES – GO TO STEP 8.

8. Spark Plug Inspection

Remove and inspect the spark plug.

Is the spark plug fouled or discolored?

- NO** – • Plugs not serviced frequently enough
• Incorrect spark plug heat range
• Incorrect spark plug gap

YES – GO TO STEP 9.

9. Cylinder compression Inspection

Test the cylinder compression.

Is the compression low?

- YES** – • Valve clearance too small
• Valve stuck open
• Worn cylinder and piston rings
• Damaged cylinder head gasket
• Improper valve timing

NO – GO TO STEP 10.

10. Carburetor Inspection

Check the carburetor for clogs.

Is the carburetor clogged?

- YES** – • Carburetor not serviced frequently enough
• Dirt getting passed the air cleaner

NO – GO TO STEP 11.

11. Lubrication Inspection

Remove cylinder head cover and inspect lubrication.

Is the valve train lubricated properly?

- NO** – • Faulty oil pump
• Clogged oil passage
• Clogged oil strainer

POOR PERFORMANCE AT LOW AND IDLE SPEED**1. Pilot Screw Inspection**

Check carburetor pilot screw adjustment.

Is the adjustment correct?

NO – See page 5-21

YES – GO TO STEP 2.

2. Intake Air Leak Inspection

Check for leaking carburetor insulator.

Is there leaking?

YES – • Loose carburetor insulator bands
• Damaged insulator

NO – GO TO STEP 3.

3. Spark Test

Perform spark test.

Is there weak or intermittent spark?

YES – • Faulty spark plug
• Fouled spark plug
• Loose or disconnected ignition system wires
• Broken or shorted spark plug wire
• Faulty ignition coil
• Faulty ignition pulse generator
• Faulty ignition switch
• Faulty engine stop switch
• Faulty ignition control module (ICM)

NO – GO TO STEP 4.

4. Ignition Timing Inspection

Check ignition timing.

Is the ignition timing correct?

NO – • Faulty ignition control module (ICM)
• Faulty ignition pulse generator

TROUBLESHOOTING

POOR PERFORMANCE AT HIGH SPEED

1. Fuel Line Inspection

Disconnect fuel line at carburetor.

Does fuel flow freely?

- NO** – • Clogged fuel line
• Clogged fuel cap breather
• Faulty fuel valve
• Clogged fuel strainer

YES – GO TO STEP 2.

2. Carburetor Inspection

Check carburetor for clogs.

Is the carburetor clogged?

- YES** – • Carburetor not serviced frequently enough
• Dirt getting passed the air cleaner

NO – GO TO STEP 3.

3. Ignition Timing Inspection

Check ignition timing.

Is the ignition timing correct?

- NO** – • Faulty ignition control module (ICM)
• Faulty ignition pulse generator

YES – GO TO STEP 4.

4. Valve Timing Inspection

Check valve timing.

Is the valve timing correct?

- NO** – Cam sprocket not installed properly.

YES – GO TO STEP 5.

5. Valve Spring Inspection

Check valve springs.

Are the valve springs weak?

- YES** – Faulty valve spring.

POOR HANDLING

Steering is heavy

- Steering bearing adjustment nut too tight
- Damaged steering head bearings
- Low tire pressure

Either wheel is wobbling

- Excessive wheel bearing play
- Bent rim
- Improperly installed wheel hub
- Excessively worn swingarm pivot bearings
- Bent frame

Motorcycle pulls to one side

- Front and rear wheels not aligned
- Bent fork
- Bent swingarm
- Bent axle
- Bent frame
- Faulty shock absorber

21. INDEX

AIR CLEANER	3-6	FRONT WHEEL (TYPE I, III)	12-11
AIR CLEANER HOUSING	5-5	(TYPE II, IV)	12-15
AIR CUT-OFF VALVE	5-13	FRONT WHEEL/BRAKE/SUSPENSION/STEERING	
ALTERNATOR CHARGING COIL	15-11	SPECIFICATIONS	1-8
BATTERY	15-6	FUEL LEVEL SENSOR	18-14
MAINTENANCE	3-14	FUEL LINE	3-4
BATTERY/CHARGING SYSTEM SPECIFICATIONS	1-9	FUEL STRAINER	5-26
BRAKE CALIPER	14-15	FUEL STRAINER SCREEN	3-4
BRAKE FLUID (TYPE II, IV)	3-14	FUEL SYSTEM SPECIFICATIONS	1-5
BRAKE FLUID REPLACEMENT/AIR BLEEDING	14-5	FUEL TANK	2-4
BRAKE LIGHT SWITCH	3-18	GEAR POSITION SWITCH	18-12
BRAKE LIGHT SWITCHES	18-11	GEARSHIFT LINKAGE	9-11
BRAKE PAD/DISC	14-7	GENERAL INFORMATION	1-2
BRAKE PEDAL/CENTER STAND	13-16	GENERAL SPECIFICATIONS	1-4
BRAKE SHOES WEAR (TYPE I, III)	3-15	HANDLEBAR	12-7
BRAKE SHOES/PADS WEAR (TYPE II, IV)	3-16	HANDLEBAR SWITCHES	18-10
BRAKE SYSTEM	3-16	HEADLIGHT	18-4
BRAKE/TAIL LIGHT	18-4	HEADLIGHT AIM	3-18
CABLE & HARNESS ROUTING	1-16	HORN	18-15
CAM FOLLOWER/SHAFT	8-6	HORN COVER	2-7
CAM FOLLOWER/SHAFT INSPECTION	8-6	HYDRAULIC BRAKE SPECIFICATIONS (TYPE II, IV)	1-8
CAMSHAFT	8-7	ICM (IGNITION CONTROL MODULE)	16-10
CARBURETOR ASSEMBLY	5-16	IGNITION COIL	16-9
CARBURETOR BODY CLEANING	5-15	IGNITION SWITCH	18-9
CARBURETOR DISASSEMBLY	5-14	IGNITION SYSTEM INSPECTION	16-5
CARBURETOR INSTALLATION	5-19	IGNITION SYSTEM SPECIFICATIONS	1-9
CARBURETOR REMOVAL	5-10	IGNITION TIMING	16-8
CHARGING SYSTEM INSPECTION	15-9	INSULATOR	5-20
CHOKE LEVER	5-11	KICKSTARTER	11-14
CLUTCH	9-6	LEFT CRANKCASE COVER INSTALLATION	10-11
CLUTCH LIFTER ARM	9-6	LEFT CRANKCASE COVER REMOVAL	10-4
CLUTCH SWITCH	18-12	LICENSE PLATE HOLDER	2-8
CLUTCH SYSTEM	3-18	LIGHTS/METERS/SWITCHES SPECIFICATIONS	1-9
CLUTCH/GEARSHIFT LINKAGE SPECIFICATIONS	1-6	LUBRICATION & SEAL POINTS	1-14
COMBINATION METER	18-6	LUBRICATION SYSTEM DIAGRAM	4-2
COMPONENT LOCATION		LUBRICATION SYSTEM SPECIFICATIONS	1-5
BATTERY/CHARGING SYSTEM	15-2	MAINTENANCE SCHEDULE	3-3
ELECTRIC STARTER	17-2	MASTER CYLINDER	14-10
IGNITION SYSTEM	16-2	MODEL IDENTIFICATION	1-2
LIGHTS/METER/SWITCHES	18-2	NEUTRAL DIODE	17-15
CRANKCASE ASSEMBLY	11-19	NUTS, BOLTS, FASTENERS	3-20
CRANKCASE SEPARATION	11-6	OIL FILTER ROTOR CLEANING	4-4
CRANKSHAFT	11-7	OIL PUMP	4-5
CRANKSHAFT/TRANSMISSION/KICKSTARTER		PILOT SCREW ADJUSTMENT	5-21
SPECIFICATIONS	1-7	PISTON	8-10
CYLINDER	8-4	POSITION LIGHT	18-4
CYLINDER COMPRESSION	7-6	REAR CARRIER	2-5
CYLINDER HEAD	7-12	REAR COWL	2-5
CYLINDER HEAD COVER	7-7	REAR DRUM BRAKE	13-13
CYLINDER HEAD/VALVES SPECIFICATIONS	1-5	REAR FENDER	2-6
CYLINDER/PISTON SPECIFICATIONS	1-6	REAR WHEEL	13-6
DRIVE CHAIN	3-12	REAR WHEEL/SUSPENSION SPECIFICATIONS	1-8
DRIVE SPROCKET	6-4	REGULATOR/RECTIFIER	15-10
ELECTRIC STARTER SPECIFICATIONS	1-9	RIGHT CRANKCASE COVER INSTALLATION	9-14
EMISSION CONTROL SYSTEMS	1-25	RIGHT CRANKCASE COVER REMOVAL	9-5
ENGINE & FRAME TORQUE VALUES	1-10	ROCKER ARM HOLDER	7-10
ENGINE IDLE SPEED	3-11	SEAT	2-4
ENGINE INSTALLATION	6-10	SECONDARY AIR SUPPLY SYSTEM	
ENGINE OIL	3-9	FUEL SYSTEM	5-22
ENGINE OIL STRAINER SCREEN	3-10	MAINTENANCE	3-11
ENGINE REMOVAL	6-6	SERVICE INFORMATION	
EXHAUST PIPE/MUFFLER	2-8	ALTERNATOR/STARTER CLUTCH	10-3
FLYWHEEL INSTALLATION	10-9	BATTERY/CHARGING SYSTEM	15-3
FLYWHEEL REMOVAL	10-6	CLUTCH/GEARSHIFT LINKAGE	9-3
FOOTPEG BAR	2-8	CRANKCASE/TRANSMISSION/CRANKSHAFT	11-3
FORK	12-24	CYLINDER HEAD/VALVES	7-3
FRONT COWL	2-7	CYLINDER/PISTON/CAMSHAFT	8-3
FRONT DRUM BRAKE (TYPE I, III)	12-20	ELECTRIC STARTER	17-3
FRONT FENDER	2-6	ENGINE REMOVAL/INSTALLATION	6-3

INDEX

FRAME/BODY PANELS/EXHAUST SYSTEM	2-2	SYSTEM DIAGRAM	
FRONT WHEEL/BRAKE/SUSPENSION/STEERING	12-4	BATTERY/CHARGING SYSTEM	15-2
FUEL SYSTEM	5-3	ELECTRIC STARTER	17-2
HYDRAULIC BRAKE	14-3	IGNITION SYSTEM	16-2
IGNITION SYSTEM	16-3	TACHOMETER	18-8
LIGHTS/METER/SWITCHES	18-3	THROTTLE OPERATION	3-5
LUBRICATION SYSTEM	4-3	THROTTLE VALVE	5-8
MAINTENANCE	3-2	TRANSMISSION	11-8
REAR WHEEL/BRAKE/SUSPENSION	13-3	TROUBLESHOOTING	
SERVICE RULES	1-2	ALTERNATOR/STARTER CLUTCH	10-3
SHOCK ABSORBER	13-20	BATTERY/CHARGING SYSTEM	15-5
SIDE COVERS	2-3	CLUTCH/GEARSHIFT LINKAGE	9-4
SIDE STAND	3-19	CRANKCASE/TRANSMISSION/CRANKSHAFT	11-5
SPARK PLUG	3-7	CYLINDER HEAD/VALVES	7-5
STANDARD TORQUE VALUES	1-10	CYLINDER/PISTON/CAMSHAFT	8-3
STARTER CLUTCH	10-7	ELECTRIC STARTER	17-4
STARTER MOTOR	17-6	ENGINE DOES NOT START OR IS HARD TO	
STARTER RELAY SWITCH	17-14	START	20-2
STATOR/IGNITION PULSE GENERATOR	10-5	ENGINE LACKS POWER	20-3
STEERING HEAD BEARINGS	3-21	FRAME/BODY PANELS/EXHAUST SYSTEM	2-2
STEERING STEM	12-31	FRONT WHEEL/BRAKE/SUSPENSION/STEERING	12-6
STORAGE TANK	5-8	FUEL SYSTEM	5-4
SUSPENSION	3-19	HYDRAULIC BRAKE	14-4
SWINGARM	13-21	IGNITION SYSTEM	16-4
SYSTEM COMPONENTS		LUBRICATION SYSTEM	4-3
ALTERNATOR/STARTER CLUTCH	10-2	POOR HANDLING	20-6
CLUTCH/GEARSHIFT LINKAGE	9-2	POOR PERFORMANCE AT HIGH SPEED	20-6
CRANKCASE/TRANSMISSION/CRANKSHAFT	11-2	POOR PERFORMANCE AT LOW AND IDLE	
CYLINDER HEAD/VALVES	7-2	SPEED	20-5
CYLINDER/PISTON/CAMSHAFT	8-2	REAR WHEEL/BRAKE/SUSPENSION	13-5
ENGINE REMOVAL/INSTALLATION	6-2	TURN SIGNAL LIGHT	18-5
FRONT WHEEL/BRAKE/SUSPENSION/STEERING	12-2	TURN SIGNAL RELAY	18-16
FUEL SYSTEM	5-2	VALVE CLEARANCE	3-8
HYDRAULIC BRAKE	14-2	WHEELS/TIRES	3-20
REAR WHEEL/BRAKE/SUSPENSION	13-2	WIRING DIAGRAM	19-2