

Split Level Classroom Table ST

Assembly Instructions



How can we improve our assembly instructions?
Your comments and suggestions are important to us.
Please e-mail us at: support@versatables.com.

Hardware & Parts List

Split Level Classroom Table

1/2-13 Leveler



Qty:4

50mm Furniture Bolt



Qty:8

20mm Furniture Bolt



Qty:24

4mm Allen Wrench



Qty:1

Caster & Caster with Lock



OPTIONAL Qty:4

Surface Grommet



Qty:1 for 30", 36" & 48"
Qty:3 for 60", & 72"

Kick Panel



Qty:1

Zip Tie & Curly Tie



Qty:5

Side Frame Panel (Left & Right)



Back Surface



Qty:1

Front Surface



Qty:1

Cross Support



Qty:4

Cable Management tray



Qty:1

OPTIONAL

ECPU



Qty:1 for 30", 36" & 48"
Qty:2 for 60", & 72"

Step 1

Levelers

Insert Levelers into Bottom Frames L & R.

Leveling Glide



Qty:4

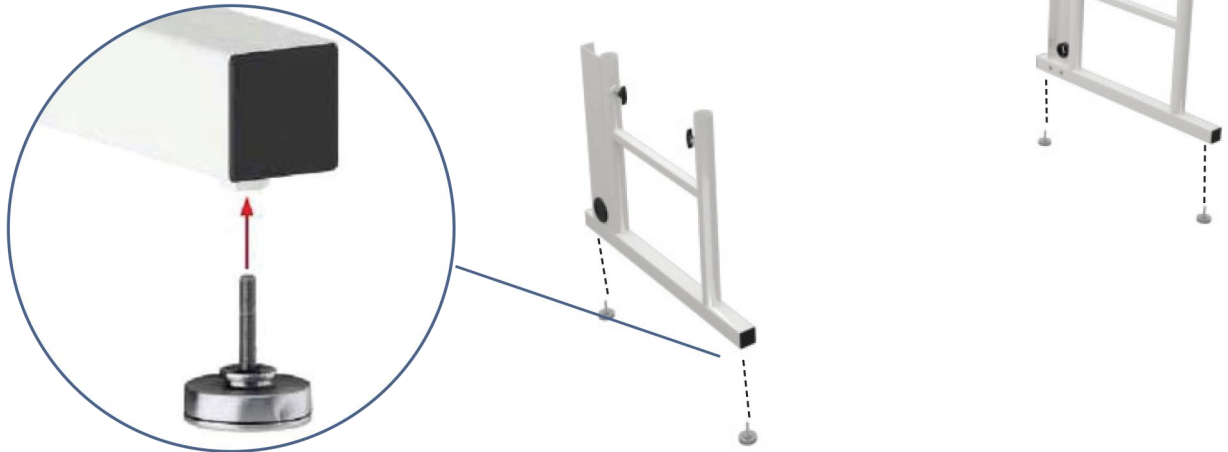

Step 2

Attach Cable Management Tray

Insert 2 20mm Furniture Bolts to each Bottom Frame half way. Then drop Cable Management tray onto screws and tighten.

20mm Furniture Bolt



Qty:4

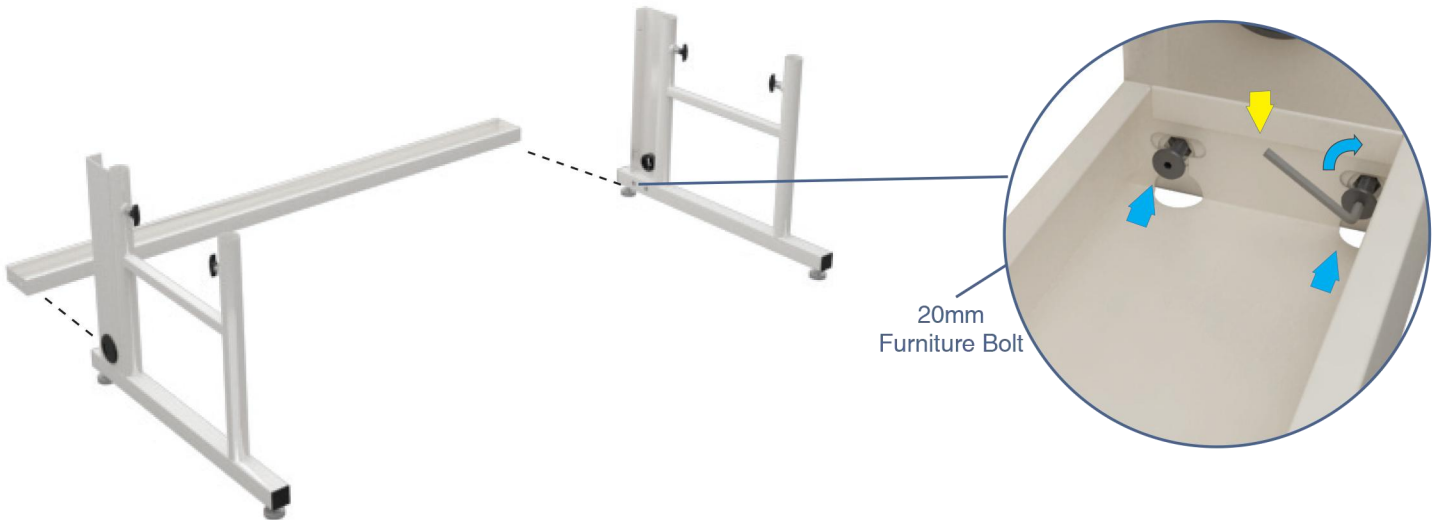

Step 3

Attach Kick Panel

Direct Kick Panel to Bottom Frame and attach it using (4) 20mm Furniture Bolts.

20mm
Furniture Bolt



Qty:4

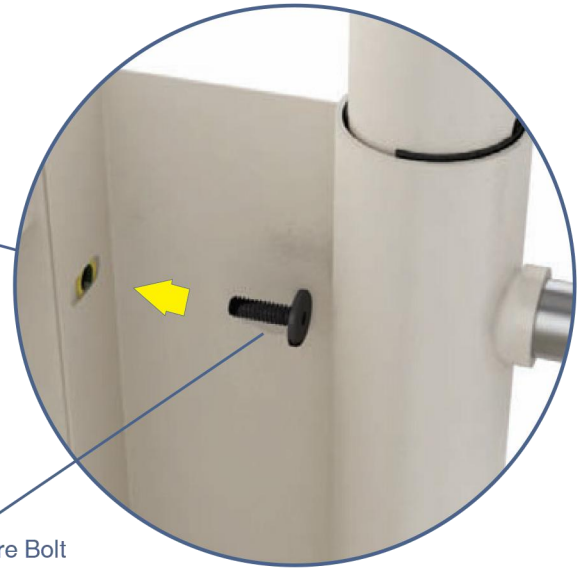
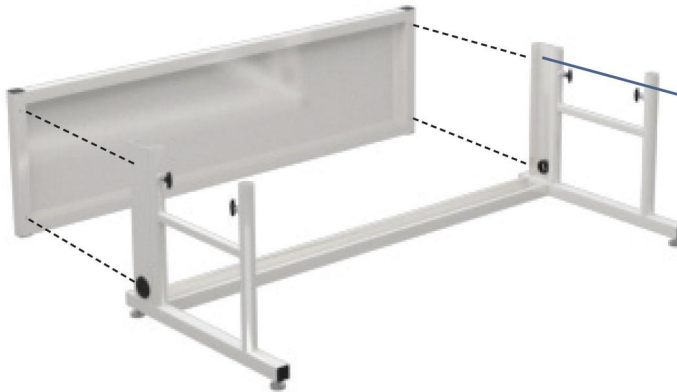

20mm Furniture Bolt

Step 4

Top Frames

Slide Top Frames.

Turn and pull to adjust the height, turn clockwise to lock pop-pin.

Once a platform is at desired height, turn pop-pin mechanism to tight and secure the table.



Step 5

Cross Supports

Attach Cross Supports to Frames using (2) 20mm Furniture Bolts per Cross Support.

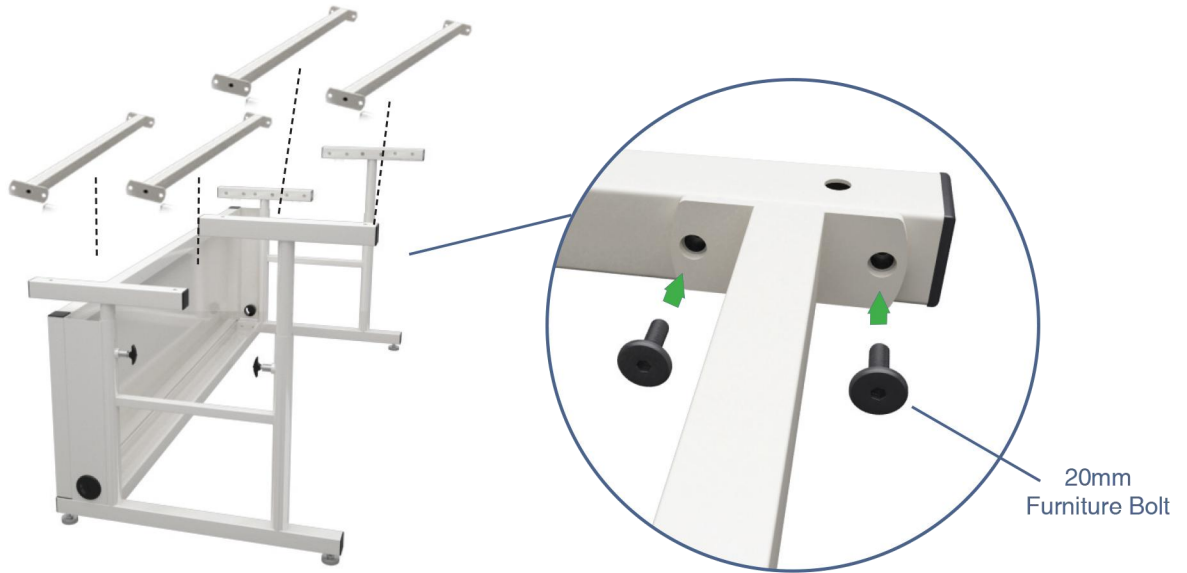

Step 6

Main and Back Platforms

Place Main and Back Surfaces on top of frames. Attach them with (4) 50mm Furniture Bolts on each Surface.

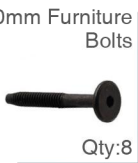

Step 7

NOTE: Steps 7 is optional in case ECPU Holders are ordered.

ECPU Holder

Insert ECPU Holder into Kickpanel notches and slide in cpu tower.

