



Surface Systems Technology

Onshore and offshore production equipment that balance reliability, safety, and effectiveness

Table of Contents

Shallow-water exploration wellhead systems

Exact* adjustable wellhead system | Centric* mudline suspension wellhead system

Drilling

Wellhead systems | Wellhead connectors | HPHT technology

Unconventional completions

CAMShale* fracturing fluid delivery and flowback service | Frac trees | Composite frac trees | F-T90* horizontal frac tree | Frac manifolds | Frac valves | Monoline* flanged-connection fracturing fluid delivery technology | Isolation systems Flowback and well testing | Fracturing support services

API 6A gate valves

Expanding-style gate valves | Wedge-style gate valves | Slab-style gate valves

API 6A actuators

Pneumatic diaphragm actuators | Pneumatic piston actuators | Hydraulic actuators | Hydraulic wireline-cutting actuators

Production

Safety systems | DryAccess* deepwater production system | Production trees | Mudline trees

Geothermal

Geothermal wellhead systems | Geothermal valves

Heavy oil

FC* fast-connect HT wellhead system | QC* quick-connect wellhead system

Surface chokes

Control chokes | Multitrim chokes | H2* needle-and-seat chokes | AOP* valve and choke technologies | Multistage chokes | Drilling chokes



Shallow-Water Exploration Wellhead Systems

Cameron shallow-water exploration wellhead systems provide significant time savings compared with conventional systems and reduce exposure to hazardous operations.

Exact adjustable wellhead system	6
Centric mudline suspension wellhead system	7

Exact Adjustable Wellhead System

The Exact* adjustable wellhead system was developed specifically to reduce rig installation time and with safety in mind. The system is suitable for jackup drilling up to 10,000-psi working pressure where adjustment from mudline to surface is required for exploration and predrilling.

The Exact-15 system is rated for 15,000-psi working pressure and is suitable for HPHT applications. Reduced installation times, no separate tension equipment required, and availability for full-sized and slimhole casing programs are among the benefits of Exact systems.

Applications

- Offshore operations
- Exploration

Advantages

- Installation under full diverter and BOP controls
- FastLock* quick wellhead connector for fast makeup connection
- 8 in of adjustment available on all surface hangers
- Indicator pins that ensure that 13 $\frac{3}{8}$ -in surface hanger is correctly engaged (advanced external adjustment drive used for 9 $\frac{5}{8}$ -in casing hangers)
- Ability to land, tension, and adjust the landing ring and lock the 9 $\frac{5}{8}$ -in adjustable casing hanger in one trip
- Solid landing shoulders and positive lock mechanism that increase surface hanger landing integrity
- No requirement for separate tension equipment for any casing string
- Reduced number of BOP installations
- Shorter installation times for increased cost savings
- Reduced manual handling for enhanced safety
- Readily available rental systems

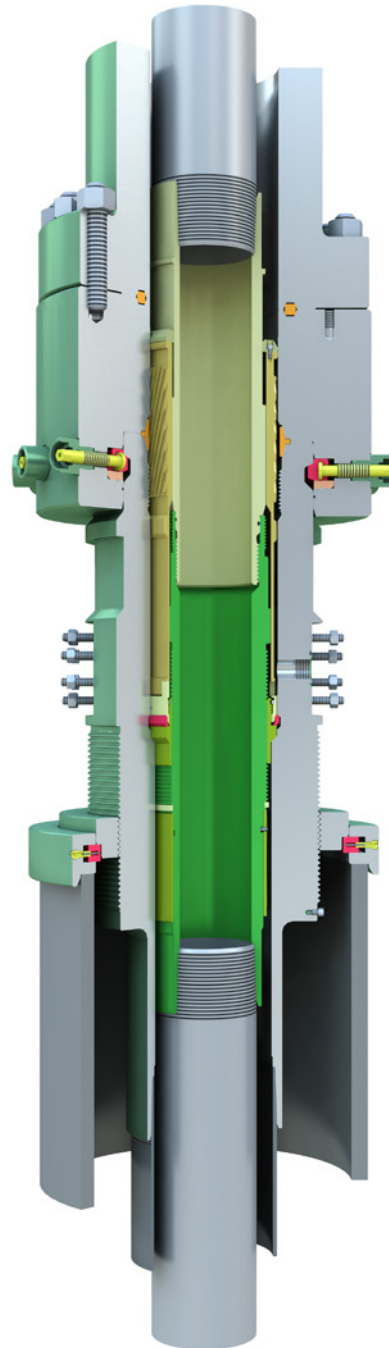

Centric Mudline Suspension Wellhead System

Featuring a patented washsleeve design that eliminates pipe rotation, the Centric* C-15 mudline suspension wellhead system is reliable in high-pressure, high-load mudline applications. The system enables landing high casing loads, increasing system versatility, and is capable of pressure ratings up to 15,000 psi. A stackdown configuration eliminates debris traps, and a unique split-cage design prevents damage to the cage during compression.

The Centric C-15 EX wellhead system is a standard offering for pressure ratings less than 10,000 psi. It features a deep stackdown design with separate running and tieback threads and incorporates a dual-centralization design and metal sealing capability. The shorter profile makes the system ideal for exploration applications. It retains many of the Centric C-15 system's features and also provides the option to reenter the well.

Applications

- Offshore operations
- Temporary abandonment
- Shallow well reentry (tieback)

Advantages

- Separate running and tieback threads in a stackdown design, ensuring the ability to tie back
- High-pressure and high-casing-load capacities
- Enhanced versatility with several different tooling options, including both threaded- and stab-in-style tieback tools (scab-type hangers also available for operations in which tieback is not required)
- High washout rates and large-diameter particle passage

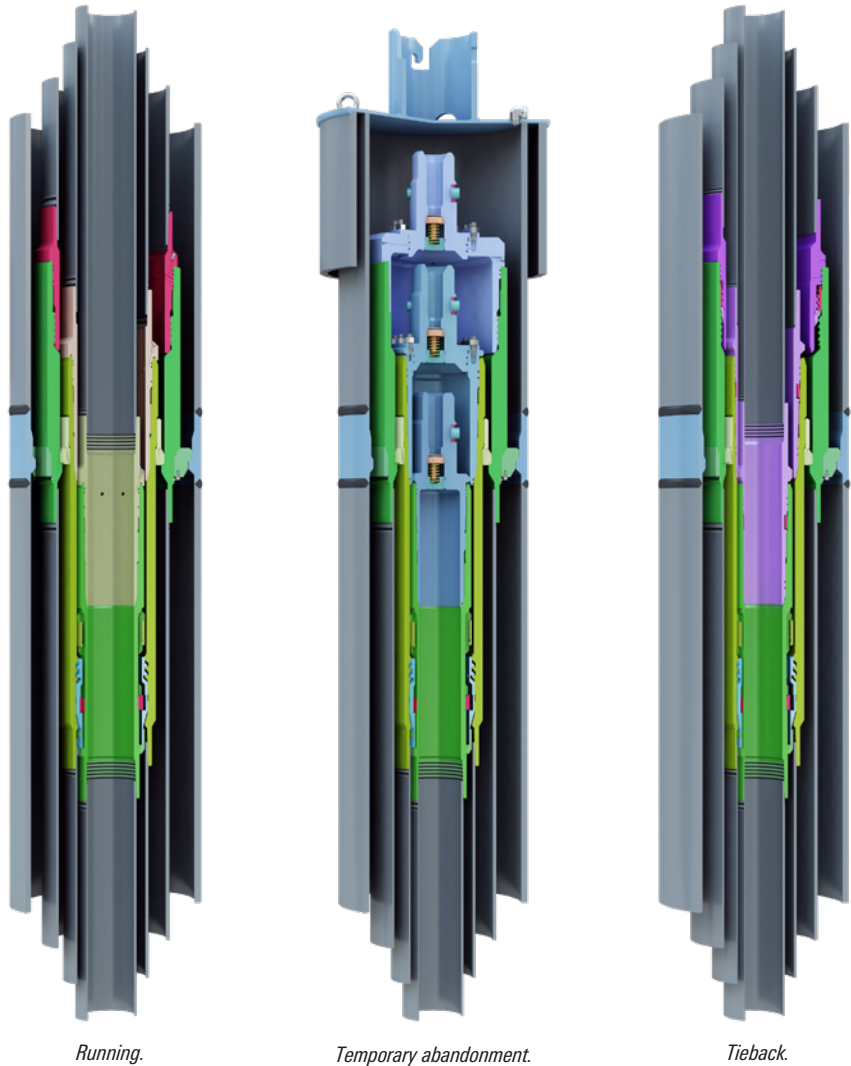

Cameron provides a suite of drilling equipment designed to reduce installation time and enhance safety.





Drilling

Cameron wellhead systems range from conventional to application-specific systems for geothermal wells, jackup rigs, unconventional plays, and more. Designed to reduce installation time and enhance safety, they use trims and proprietary sealing technologies for expected well conditions. Cameron was the first to engineer surface wellhead systems rated to 30,000 psi and 450 degF and qualified per API 6A Appendix F.

Wellhead systems

IC* conventional wellhead system	8
Drill-through wellhead system	9
MBD* multibowl diverter wellhead system	10
MN-DS* multibowl nested-diverter snap-ring wellhead system	11
SOLIDrill* modular compact wellhead system	12
CSW* conductor-sharing wellhead system	13
M-MC* metal modular compact wellhead system	14
Fontus* configurable compact wellhead system	15

Wellhead connectors

FastClamp* conventional API ring gasket wellhead connector	16
FastLock* quick wellhead connector	17
FlangeLock* low-torque wellhead connector	18
SlipLock* slip-type casing connection system	19
HPHT technology	20

IC Conventional Wellhead System

The versatile IC* conventional wellhead system product line incorporates a wide range of slip-type and mandrel casing hangers and packoffs, including the automatic slip-type hanger, which uses casing weight to energize the annular seal. Rated to 10,000 psi, the IC wellhead system can thus be configured to meet many service conditions. It incorporates the lower casing head housing and hanger as well as the subsequent casing head spools and hangers. It is compatible with all our tubing spool and hanger configurations.

Applications

- Offshore and onshore drilling and production

Advantages

- Straight-bore design with a 45° load shoulder
- Working pressure up to 10,000 psi [68.9 MPa] (excluding tubing stool)
- Operating temperatures from -20 to 150 degF [-29 to 65 degC]
- Hangoff capacity up to 50% of pipe body yield
- Casing head housings and spools: IC-2, IC-2-BP, and IC-2-L
- Casing hangers: IC-1, IC-1P, and IC-2 slip and seal assemblies
- Optional secondary seals and packoff bushings
- Interchangeability
- Compatibility with many configurations

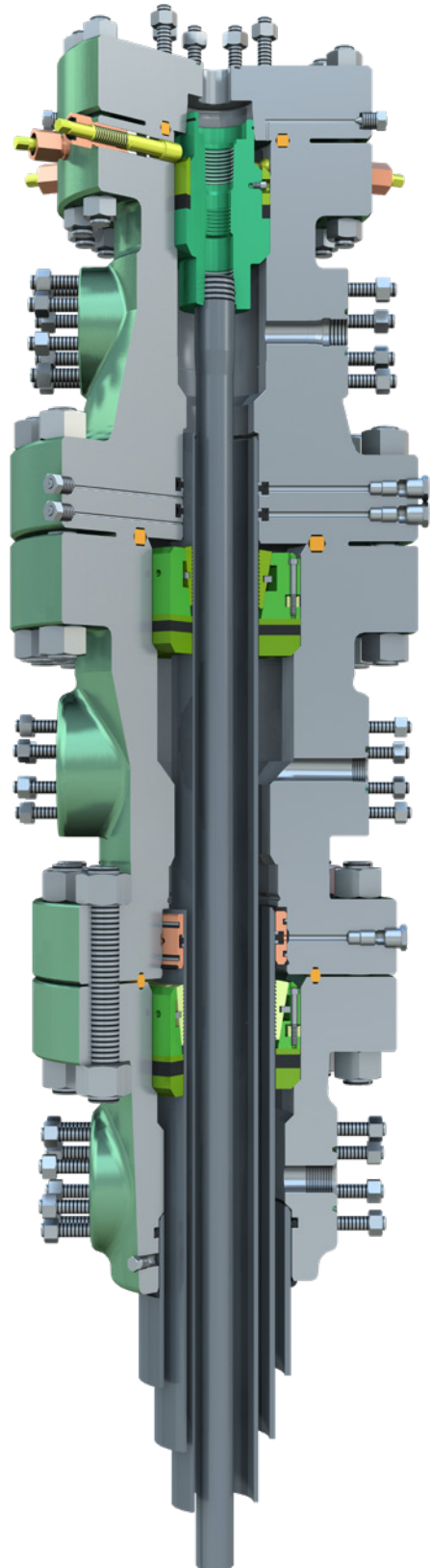

The IC wellhead system uses a straight-bore design with a 45° load shoulder.

Drill-Through Wellhead System

The drill-through wellhead system maximizes efficiency by streamlining drilling operations. Well control is achieved with one BOP rig-up, resulting in safer drilling activities and providing significant time savings that reduce rig costs. Mandrel hangers eliminate the need to set slips and perform rough and final casing cut. Rig-up and rig-down is faster, fewer personnel are required during the process, and the period of time personnel need to work under suspended loads in confined area is minimized. Additionally, hot work during the drilling phase is not required.

Applications

- Shale drilling
- Onshore drilling and production

Benefits

- Eliminated need for hot work during drilling
- Reduced required BOP connections
- Fewer personnel required during process
- Minimized time spent working under suspended loads in a confined area
- Expedited rig-up and rig-down

Features

- Casing head landing joint that is tailored to specific rig kelly bushing to ensure proper elevation of cementing head on rig floor
- No requirement for B-section spool when drilling out for liner casing, saving an estimated 8–12 h
- Hanger design with integral flutes that enable cement returns to pass up through the BOP stack
- Packoff and bit guide that are run through the BOP stack, locked in place, and tested
- Positively locked-in-place packoff during tubing head installation
- Left-hand Acme thread for quick makeup and assurance of proper backout and removal of mandrel hanger running tool

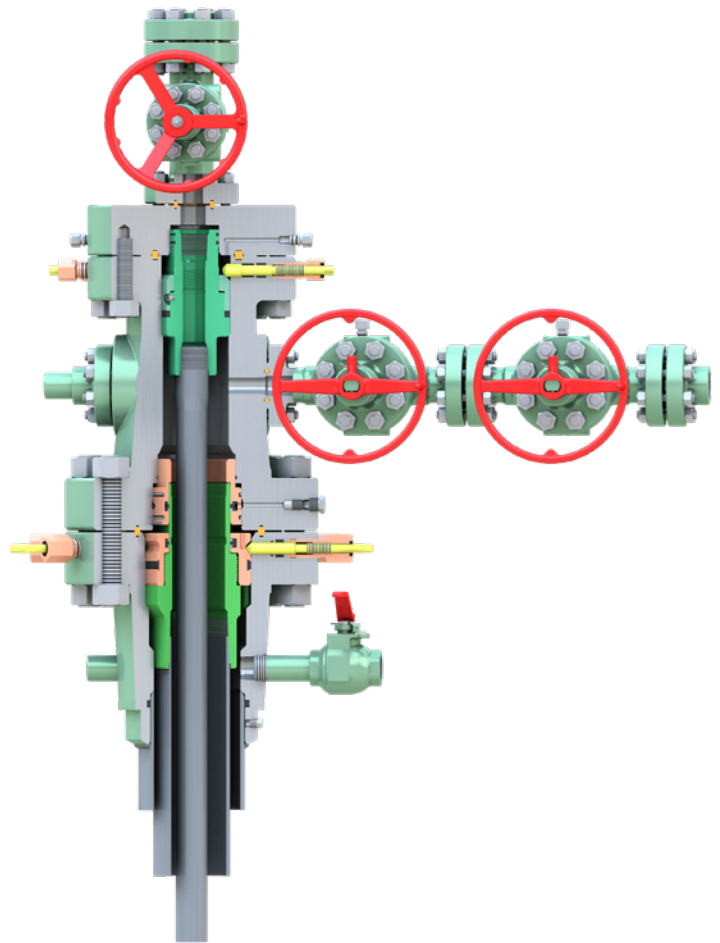

MBD Multibowl Diverter Wellhead System

MBD* multibowl diverter wellhead systems are time-saving two-stage wellhead systems designed specifically for offshore applications. They are ideal for shallow-gas environments and unconsolidated formations. The multibowl design enables running two casing strings in one casing head housing. The MBD system has a working pressure rating of 3,000 psi and can be used in moderate to severe service conditions.

Applications

- Offshore drilling
- Large-bore operations

Advantages

- Compatibility with mandrel casing hangers, emergency slip-type hangers, or a combination of both
- Availability with butt-weld connectors and SlipLock* wellhead connectors and 4-in line pipe outlets for cement return
- Positive sealing and testing of casing strings hung in the casing head before disconnection of diverter
- Full range of completion possibilities, including MBS* multibowl and IC conventional wellhead systems
- Ability to run two strings of casing through the diverter, saving a rig-up and rig-down cycle

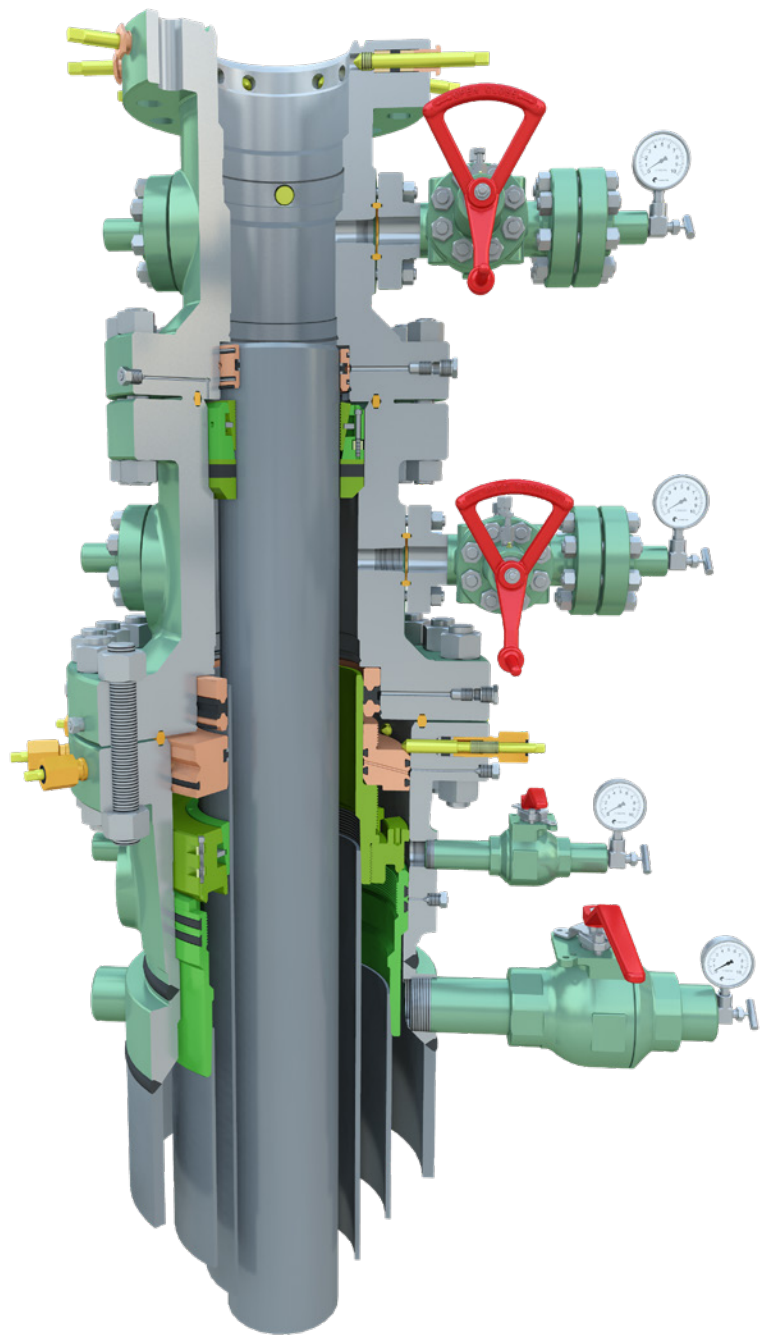

MN-DS Multibowl Nested-Diverter Snap-Ring Wellhead System

The MN-DS* multibowl nested-diverter snap-ring wellhead system is specifically designed for shale plays. Its compact design is configurable to eliminate intermediate casing strings and enables the wellhead system to be run through a diverter riser, saving time and cost. The system enhances safety and well integrity because it uses internal mechanical locking rings rather than external locking mechanisms such as lockscrews, and it has no unnecessary body penetrations. Eliminating lockscrews—which are widely used in conventional wellheads—significantly reduces potential leak paths and facilitates any wellhead intervention under the BOPs that may be required during drilling.

Applications

- Shale drilling
- Onshore drilling and production

Advantages

- Spin-on flange design that enables running wellhead through a diverter riser
- Internal lockdown hangers that eliminate penetrations from lockscrews in the housing
- Production casing hanger that can be plugged using either a threaded or latch-type backpressure valve (BPV)
- Individual contained annulars sealed using a retrievable packoff that enable the use of fluted mandrel hangers and the ability to replace casing hanger seals if necessary
- Robust studded configuration of both upper and lower housing outlets
- Option to complete as a one-stage system if intermediate casing is not required
- Reduced cost of inventory with common internal components and running tools used in both 5,000- and 10,000-psi systems

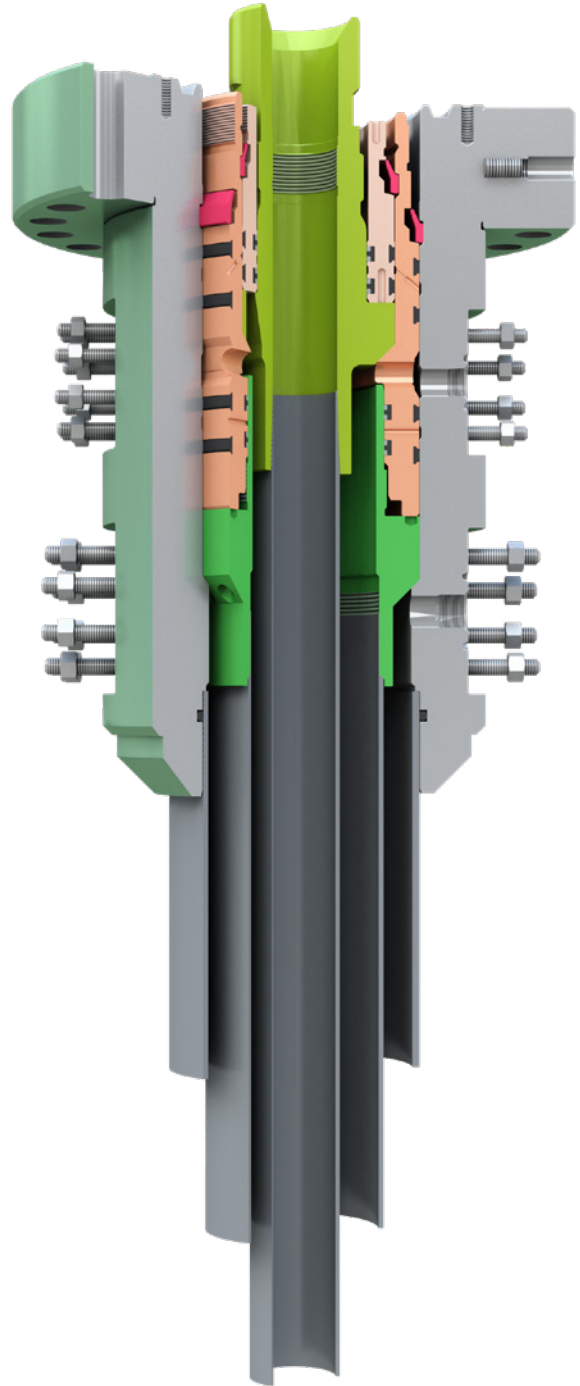

SOLIDrill Modular Compact Wellhead System

Correctly installing the wellhead is crucial to drilling and workover operation success. But most conventional installations involve landing tubing hangers on top of the casing hanger packoff's flat area, where debris can accumulate. This condition causes the wellhead to be misaligned, preventing proper installation and resulting in NPT. For operators conducting drilling and workovers involving complex land or deepwater wells, these challenges are accentuated.

Such conditions are mitigated with the SOLIDrill* modular compact wellhead system. Available in either two- or three-stage arrangements with 11-in and 13 $\frac{5}{8}$ -in nominal sizes, the SOLIDrill system has a compact, unitized housing and provides operational flexibility in a single system. The system is designed to endure extreme operating conditions, pressures up to 10,000 psi, and severe kickoff well angles up to 60° kickoff at 80 m while increasing safety and efficiency. Its proprietary design reduces the possibility of hanger tilt and secures reliable hanger alignment while reducing wellhead debris.

Applications

- Onshore and offshore drilling and production

Advantages

- Accommodation of different casing programs and a wide range of tubing programs, including single tubing, dual tubing, and completions with ESP cable penetrator, from a single system and with minimal tooling
- Self-aligning hanger and centralizing features
- Optional temporary lockdown when landing casing hangers to facilitate cementing
- Debris-tolerant design with proprietary profiles and features
- Optional feedback capability on housing misalignment
- Position indication for assurance of correct landoff and installation
- Reduced maintenance costs and exposure to potential openhole and lost-time incidents with reduced number of BOP connections, wellhead penetrations (no lockscrews), and through-BOP and -diverter operations
- Design with quick connectors and diverter connections and reduced BOP connections, resulting in rig-time savings of up to 50%

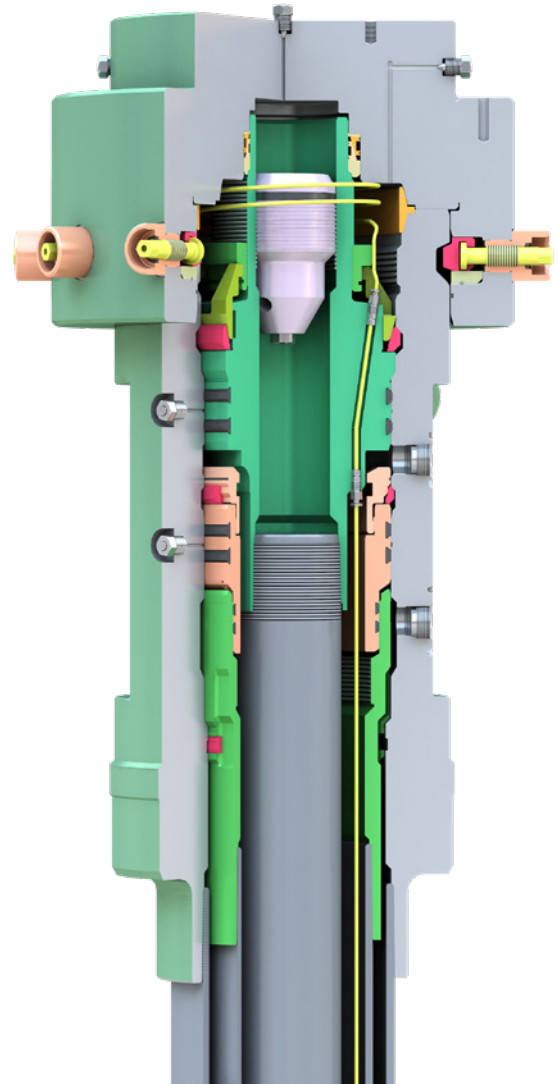

CSW Conductor-Sharing Wellhead System

CSW* conductor-sharing wellhead systems enable drilling of up to three dual-completion wells from a single slot, saving up to 20% on individual well costs and reducing platform size. The CSW system is available in 9-in, 11-in, and 13½-in nominal sizes and working pressures to 10,000 psi. It is suitable for moderate to severe working environments.

Applications

- Offshore drilling and production

Advantages

- No commitment requirement for second or third well before spudding the first well
- Reduced wellhead and BOP installation requirements for time savings, reduced openhole exposure, and minimized HSE risk
- Downtime reductions through use with CAMFORGE* weldless bottom casing connection system and SlipLock slip-type casing connection system
- Reduced costs of both equipment and tooling through the use of modular components

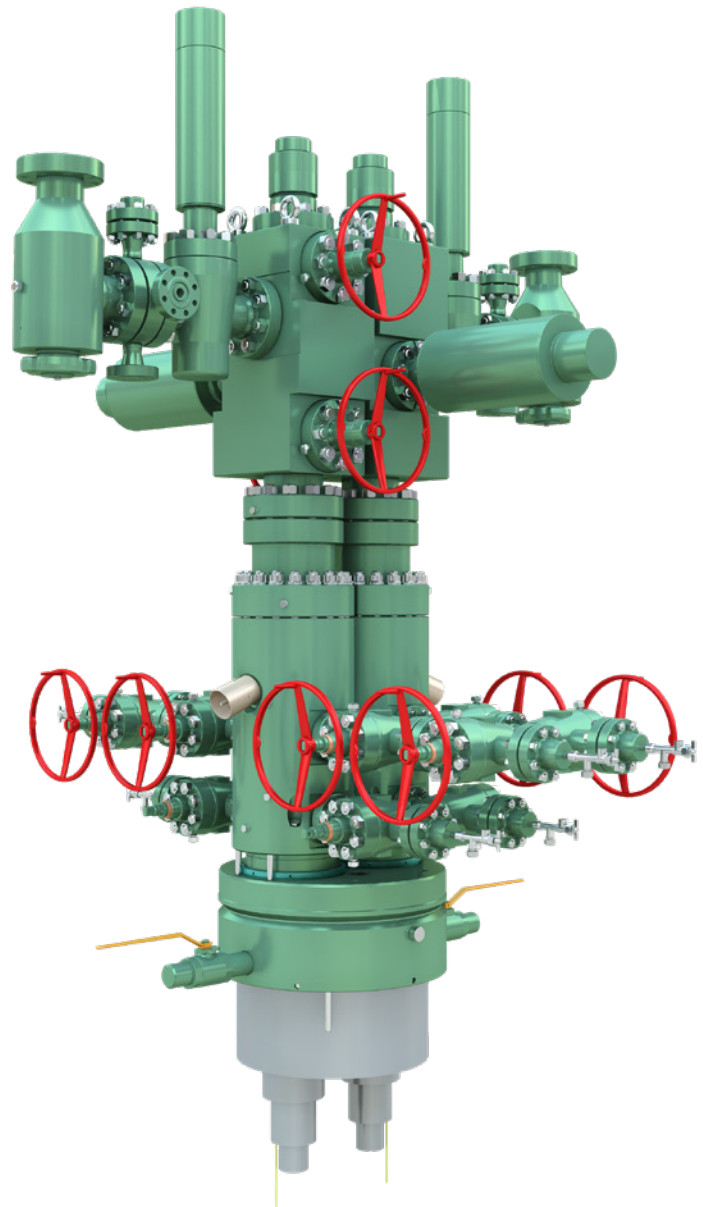

The CSW wellhead system enables multiple wells to be drilled from a single platform slot.

M-MC Metal Modular Compact Wellhead System

The M-MC* metal modular compact wellhead system is designed as an onshore or offshore multibowl wellhead system. Its ease of operation enhances safety and makes it one of the most efficient systems available. It is provided in either two- or three-stage arrangements, 13 $\frac{5}{8}$ -in through 18 $\frac{3}{4}$ -in nominal sizes, and pressure ratings to 15,000 psi. It can be used in severe service conditions and meets API 6A standards.

Applications

- Offshore drilling and production
- HPHT operations

Advantages

- Use of field-proven 13 $\frac{5}{8}$ -in, 15,000-psi FastLock quick wellhead connector, which can be made up in approximately 20 min and reduces BOP connections, resulting in typical rig-time savings of more than 50%
- High-pressure version that features a supplemental high-strength load shoulder, enabling a fullbore opening and the ability to hang two long strings of casing and a 15,000-psi full blind pressure end load
- Internally biased casing hanger lockdown rings for more positive lockdown
- Reduced exposure to openhole and HSE incidents with fewer BOP connections, wellhead penetrations, and through-BOP and -diverter operations
- Reliable, field-proven design with no plastic packing or lockscrews
- Availability of continuous control lines that can significantly reduce maintenance costs

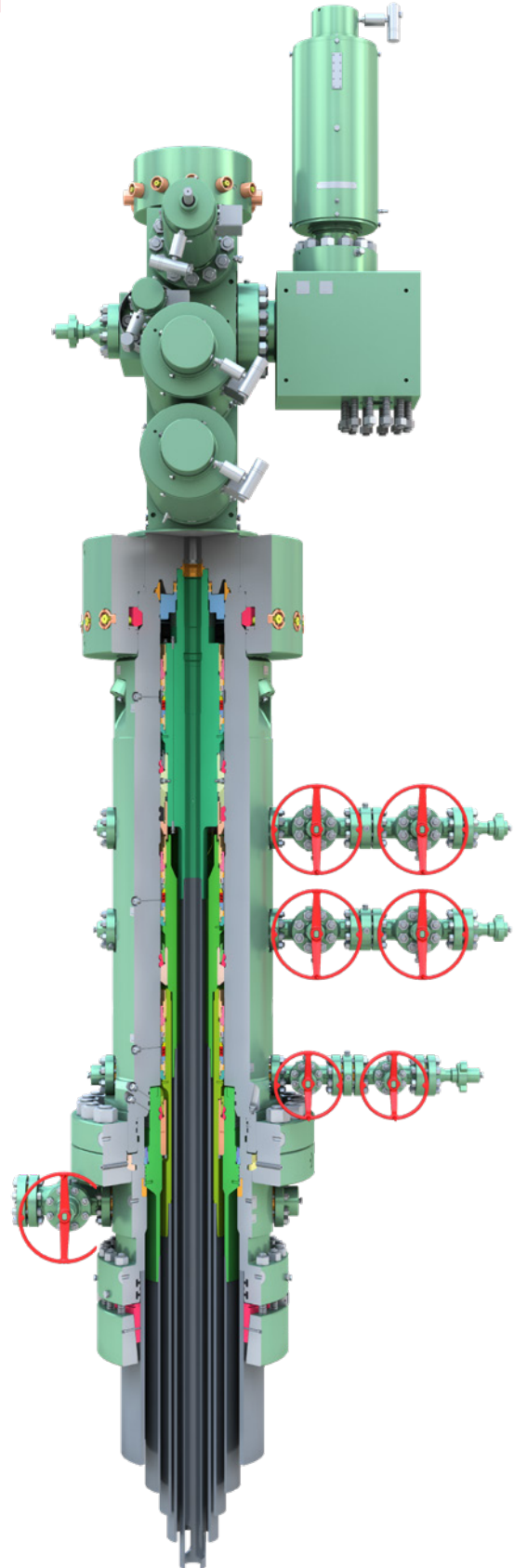

Fontus Configurable Compact Wellhead System

The Fontus* configurable compact wellhead system provides a standard global offering that offers multiple advantages—configurability, robustness, reliability, extensive service life, and reduced footprint. This next-generation wellhead system is engineered with the evolution of the MRD* recessed-bore metal-to-metal seal and CANH* rough casing metal-to-metal seal packoff that can

- set or remove on a low axial load for ease of installation or workover intervention
- simplify installation from push-fit installation, reducing any NPT risk caused by rotation
- reduce system height by reduction of annular packoff size
- enable a single-run for a combined hanger and packoff installation.

As a result, the customer saves both time and money during drilling operations.

Applications

- Land and offshore operations
- Drilling and production

Advantages

- Global-standard 18 $\frac{3}{4}$ -in metal-to-metal (MTM) and elastomeric offering
- Incorporation of quick connectors on both starter and compact head for fewer BOP connections, wellhead penetrations, and through-BOP and -diverter operations
- Zero-rotation, push-fit, and low-setting-load MTM packoff
- Single-trip hydraulic running tools for both casing and tubing hangers
- Interchangeable packoffs between MTM and elastomeric seals on each casing stage, enabling full system configurability
- 50% height reduction compared with previous dual MTM modular compact wellhead systems
- Debris and alignment tolerance design through proprietary profiles and features
- System validation to temperatures from -20 to 350 degF [-29 to 180 degC] and pressures up to $10,000$ psi
- Accommodation of up to 10 control lines within completion string

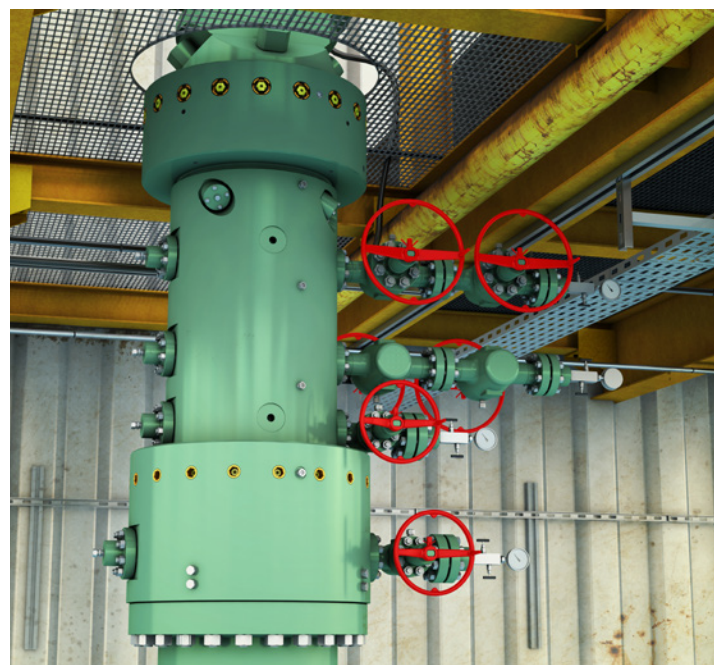
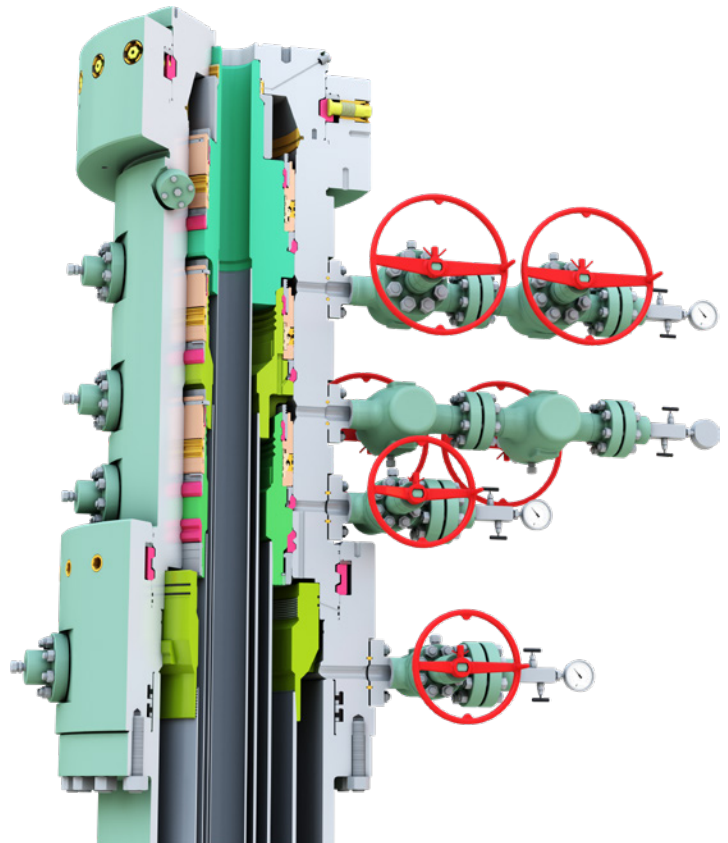

The Fontus configurable compact wellhead system enables push-fit installation and single-trip tooling for maximized operational efficiency.

FastClamp Conventional API Ring Gasket Wellhead Connector

The FastClamp* conventional API ring gasket wellhead connector is designed to provide a safer, faster, and easier method of installation when compared to the conventional clamp.

The FastClamp connector offers simple support guide rods to permanently attach the clamp halves to one of the mating hubs. The guide rods, two for each clamp half, are threaded into the outside diameter of the hub.

These rods support the weight of the clamp halves and enable the halves to be pushed together or pulled apart to close or open the connection. The clamp segments can be locked in the open position by installing a cotter pin in the bolts. The rods also provide a positive stop, which prevents the clamp halves from falling off.

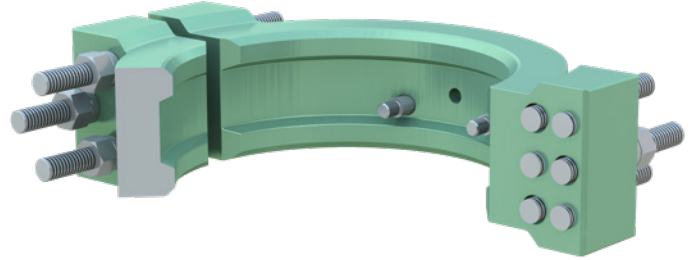

Applications

- Onshore and offshore operations
- Quick connections

Advantages

- New installation method that does not require tugger lines to help position the clamp halves around the hub and reduces handling requirements to position and install the clamps on the hubs
- User-friendly design manipulation without the use of special equipment
- Clamp segment alignment that is maintained by guide rods, increasing the number of connection bolts and thereby decreasing the force needed to make up the bolts, eliminating the need for large torque wrenches

FastLock Quick Wellhead Connector

FastLock* quick wellhead connectors are designed to meet the handling safety and makeup time requirements for today's drilling and production. The majority of connections on surface and platform drilling and production equipment have either flanged or clamped connectors. While these connectors have their own advantages, our FastLock connector is designed to overcome some of their disadvantages. The result is a connector that uses field-proven Cameron concepts and technology combined with additional performance features.

Applications

- Onshore or offshore operations
- High-pressure applications
- Quick connections

Advantages

- Reduced torque requirements with low-friction coating on sliding surfaces and 25° hub angle
- Improved safety with no hub-face separation up to test pressure
- No loose parts that need to be installed when running
- Ease of repair with ability to replace all operating components subject to wear in the field
- Secondary release mechanism for retracting the drivescrews
- Lab makeup time of 15 min for 13⁵/₈-in, 15,000-psi version

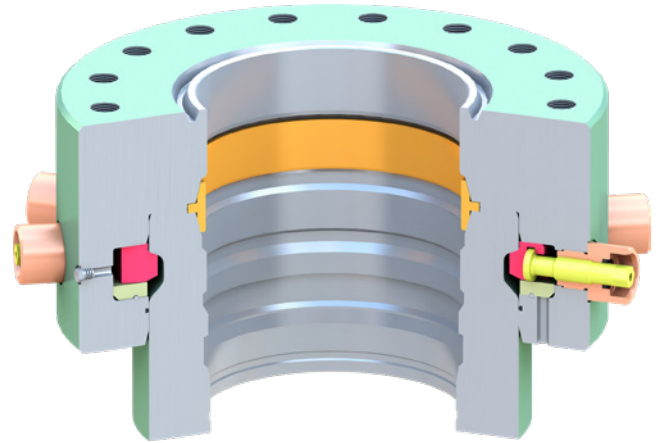

A qualified Cameron technician monitors wellhead performance.

FlangeLock Low-Torque Wellhead Connector

FlangeLock* low-torque wellhead connectors combine the fast makeup and low-torque requirement of FastLock quick wellhead connectors with the inherent low cost of flange connections. They are designed specifically for completion applications. After removal of the FastLock connector, the FlangeLock connector can be bolted directly to the FastLock connector hub.

Applications

- Onshore and offshore operations
- Quick connections

Advantages

- Proven metal-to-metal sealing gasket
- Direct attachment to the FastLock connector hub
- Significantly smaller OD compared with the equivalent API flange
- Greater number of smaller cap screws, keeping the makeup torque within the range of lightweight, compact torque wrenches
 - Makeup torque of screws on 13⁵/₈-in, 5,000-psi connector: 970 ft.lbf
 - Makeup torque of screws on 20³/₄-in, 3,000-psi connector: 660 ft.lbf

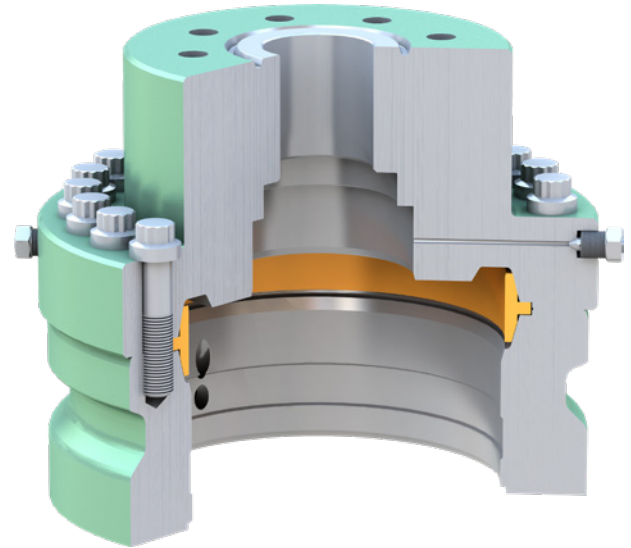

SlipLock Slip-Type Casing Connection System

The SlipLock* slip-type casing connection system can be used as an alternative to the conventional weld-on or threaded casing connection. The field-proven design incorporates the use of slip segments loaded to a specified torque, providing a quick and reliable connection between the casing head and the casing. A dual-annular seal enables testing between the seals.

Applications

- Onshore and offshore operations
- Quick connections

Advantages

- Annular seal created by plastic-energized P* radially energized elastomer injection seal or T* radially energized square-cut nonextrusion elastomer seal
- Time savings through elimination of weld-on threaded wellhead connection procedures
- No loose parts to be handled during installation
- Predetermined, specified torque makeup that is calculated for each individual application
- No requirement for welding or hot work permit

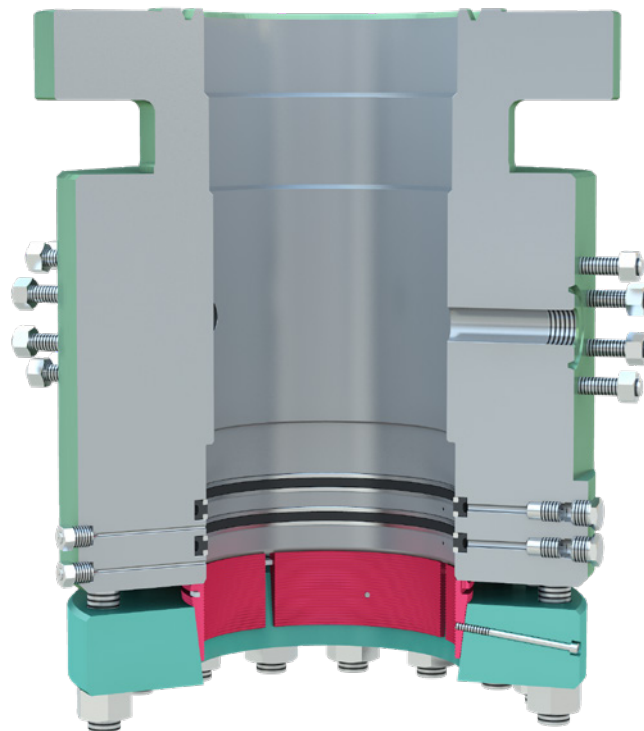

HPHT Technology

Cameron offers a suite of technologies that can operate in high-pressure, high-temperature applications up to 30,000 psi and 450 degF.

- Our high-capacity slip hanger is tested to 3,000,000-lbf casing load when installed in the S-bowl.
- The CANH rough casing metal-to-metal seal and MTBS Hanger recessed-pocket metal-to-metal seal are qualified to API Spec. 6A Annex F (30,000 psi at 450 degF).
- Our FLS extreme service API 6A slab-style gate valves, FLS-R large-bore HP API 6A slab-style gate valves, valve removal plug lubricators, and CC20 control choke are proved to withstand demanding HPHT service.

HPHT Wellhead Seals

- **CANH seal**—Dependable metal-to-metal seal for high- and low-pressure containment of fluid and gas on machined hanger necks, rough casing, and recessed bores.
- **MTBS Hanger seal**—Critical-service metal-to-metal design that is recessed below the hanger OD to provide protection while running through the BOP stack.
- **SB hanger seal**—Supported on an independent load shoulder above the slips to enable replacement at full-rated casing load capacity.
- **P radially energized elastomer injection seal**—Energized by injecting plastic packing between the wellhead body and seal element to affect a seal in moderate service environments.

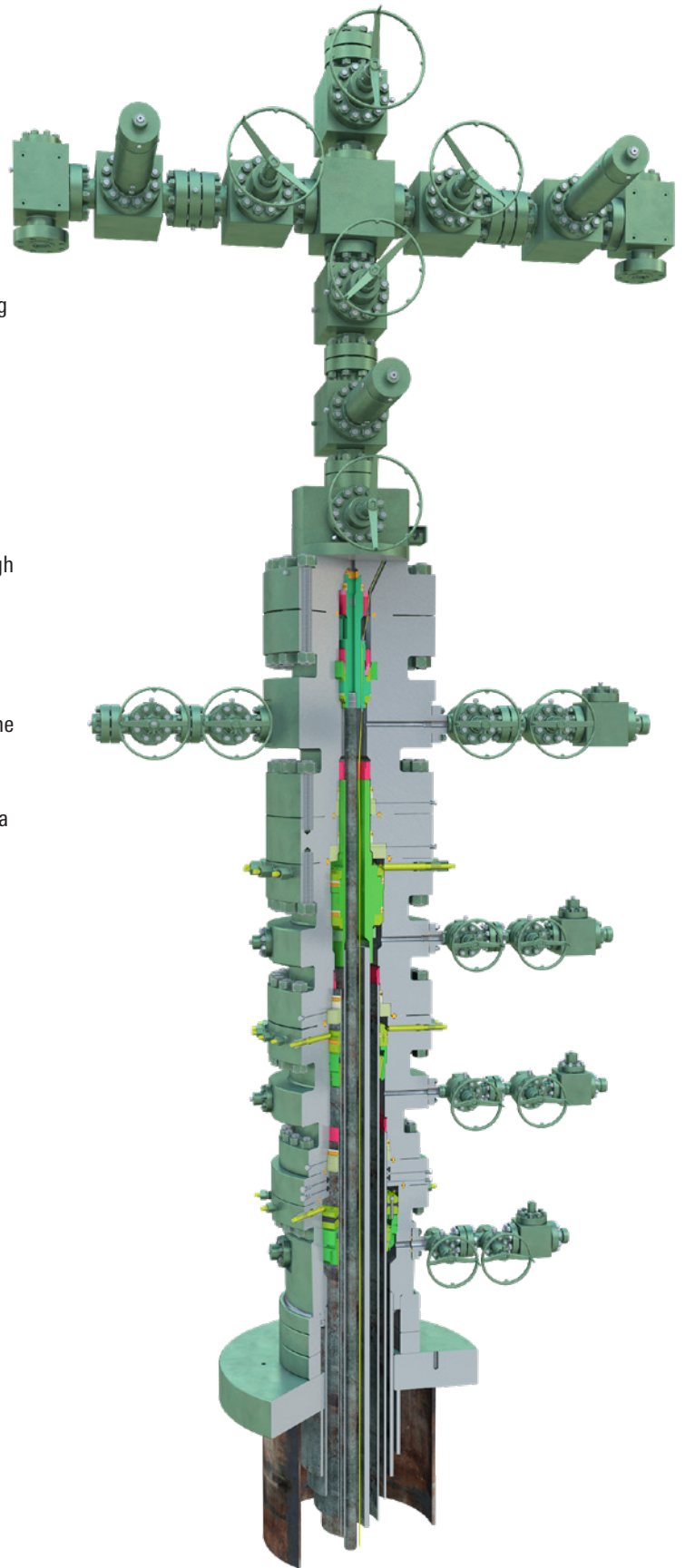



Unconventional Completions

Cameron provides fracturing fluid control and monitoring services and technologies through to flowback and well testing to enhance the safety and efficiency of fracturing operations for single wells or multiwell pads. Equipment rental and purchase options are both available.

CAMShale fracturing fluid delivery and flowback service	22	Flowback and well testing	
Frac trees	24	Plug catchers	36
Composite frac trees	26	Sand separators	36
F-T90 horizontal frac tree	27	Gate-valve choke manifolds	37
Frac manifolds	28	Plug valve choke manifolds	37
Frac valves	29	Well test separators	38
Monoline flanged-connection fracturing fluid delivery technology	30	Emergency shutdown (ESD) valves	38
Isolation systems		Indirect heaters	39
FracGUARD* isolation head	31	Hydraulic choke control trailers	39
CAMFRAC* isolation system	32	Flare systems	40
Fullbore completion tubing equipment	33	Fracturing support services	40
Standard completion tubing equipment	34		

CAMShale Fracturing Fluid Delivery and Flowback Service

For operators with challenging unconventional play economics, where maximizing operational efficiency while maintaining the technical integrity of all high-pressure activities is essential, the CAMShale* fracturing fluid delivery and flowback service is the answer.

The service provides seamless delivery of hydraulic fracturing fluid from the pumping service provider's missile trailer to the wellbore and through to flowback. Comprehensive, integrated service and support from a single provider helps optimize overall efficiency while reducing NPT, costs, and the environmental impact of unconventional completions.

Multiskilled crews minimize wellsite personnel and reduce logistics demands. The continuity of trained personnel, innovative equipment, and rigorous maintenance programs improve operational integrity and safety.

By removing as much nonproductive preparatory work from critical-path operations as possible, the CAMShale service helps you reach first oil or gas faster and minimize the cost per barrel of oil equivalent.

Streamlined operations through technology integration

The service incorporates frac trees — including composite frac trees, which are shorter and lighter than the conventional models; flexible, modular fracture manifolds that enable control of fluid flow to multiple wells, eliminating rig-up and rig-down between stages; flowback equipment and well test separators tailored to operating conditions and regulatory requirements; and multiskilled trained personnel using standard procedures developed through a proprietary Schlumberger process improvement methodology.

Technologies and services that bring significant advantages to the CAMShale service include

- Monoline* flanged-connection fracturing fluid delivery technology, which provides a safer, faster, cleaner alternative to conventional frac iron for multiwell and pad operations
- composite frac trees, including F-T90* horizontal frac trees, which are 50% shorter and 25% lighter compared with conventional frac trees.

Continuity of ownership and competency

With the CAMShale service, a Cameron crew is on site from the time fracturing fluid delivery equipment is installed through the entire fracturing operation, flowback, and any well testing. The result is a smooth transition from completion to production and a single point of contact for the entire surface completion beyond the pressure pumping provider. Additionally, the service assists in contingency planning. For example, in the event of a screenout, flowback equipment and a trained crew are already on site to clean out the wellbore in the shortest possible time.

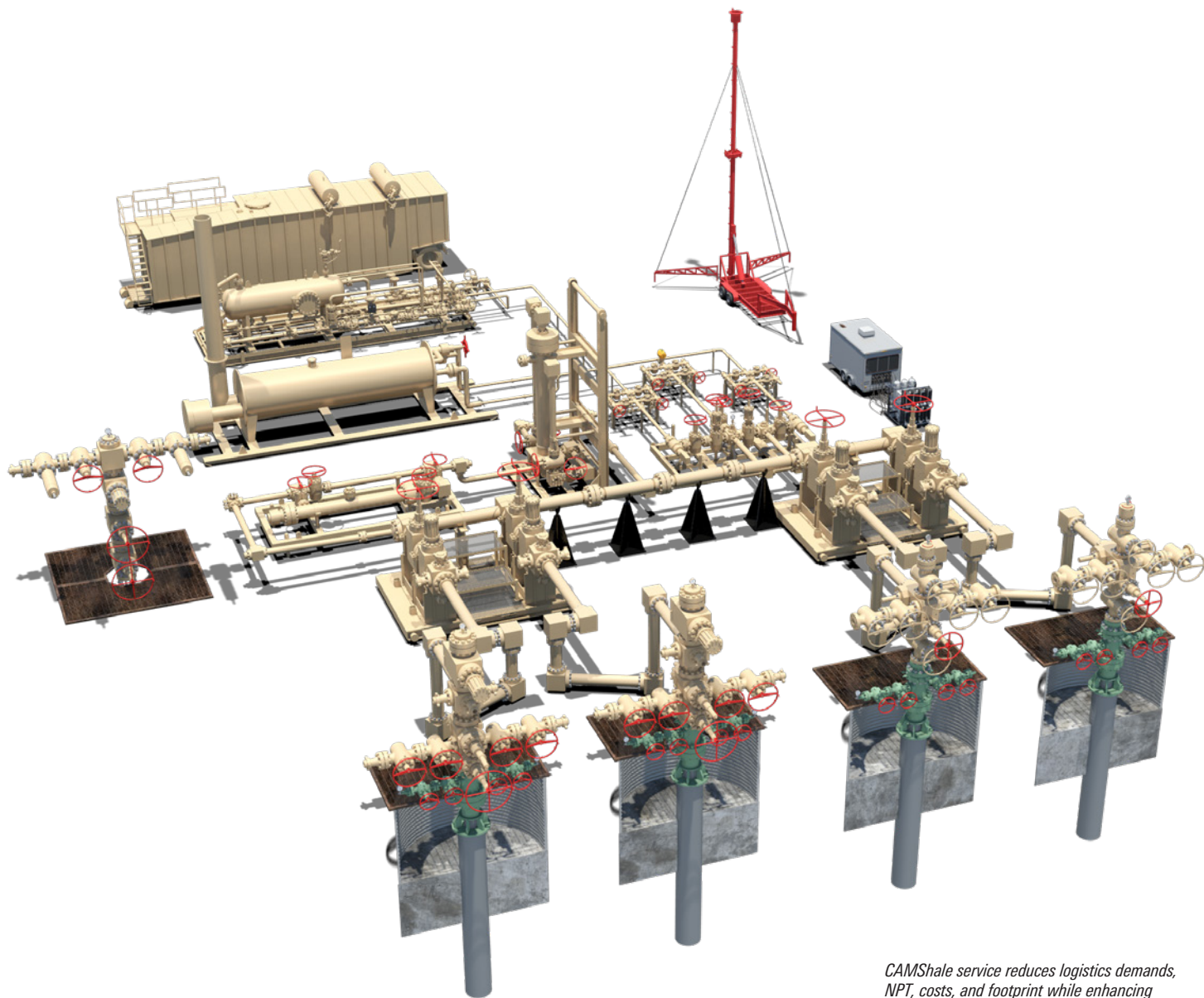

CAMShale service reduces logistics demands, NPT, costs, and footprint while enhancing efficiency, operational integrity, and safety.

Frac Trees

With the advent of large-scale fracturing operations, fracturing equipment has undergone an evolution in design as the systems have been tasked to cope with an aggressively corrosive and abrasive service life that is well beyond the original design parameters. Valves used in fracture stimulation processes have a significantly different life cycle than those used in production.

Cameron frac trees provide a substantial advancement in performance for shale applications by providing increased durability, flexibility, and operational safety. They have also been specially manufactured to endure the sustained pressure pumping of erosive fracturing fluids. The value of these capabilities becomes obvious as operators push lateral lengths and increase fracturing stages to increase completion and production performance for their shale applications. Our frac trees are available in conventional and vertical and horizontal composite configurations in sizes up to 7 in and working pressures up to 15,000 psi.

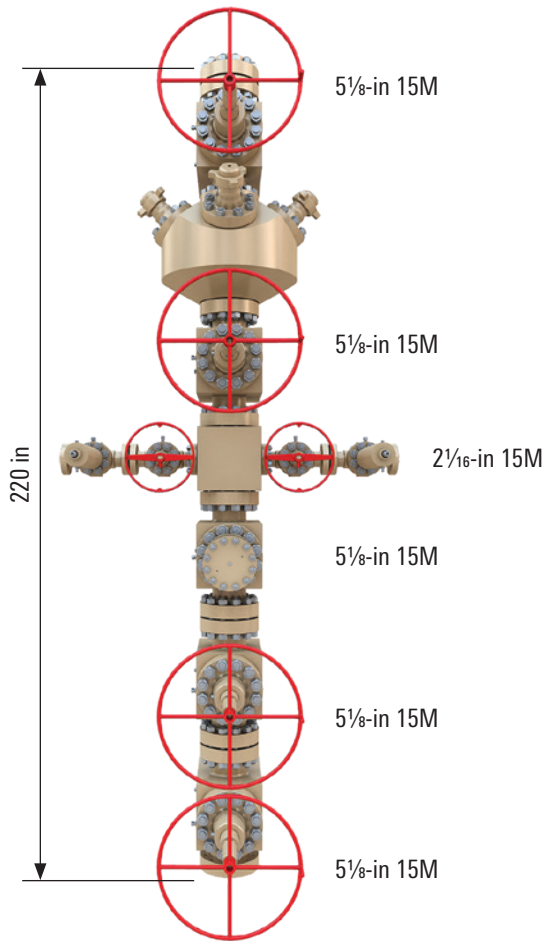

Conventional frac tree.

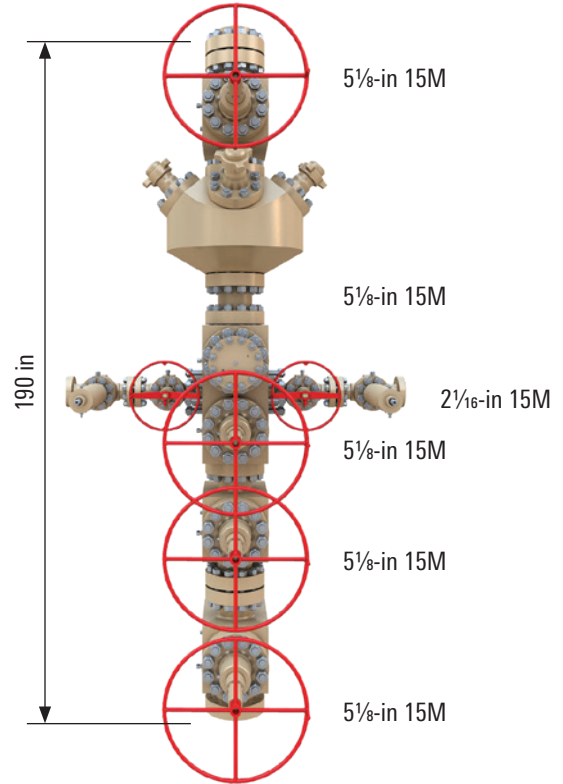

Composite frac tree.



The composite frac tree's reduced height decreases the bending stress transferred from the goat head to the tree and wellhead connections below.

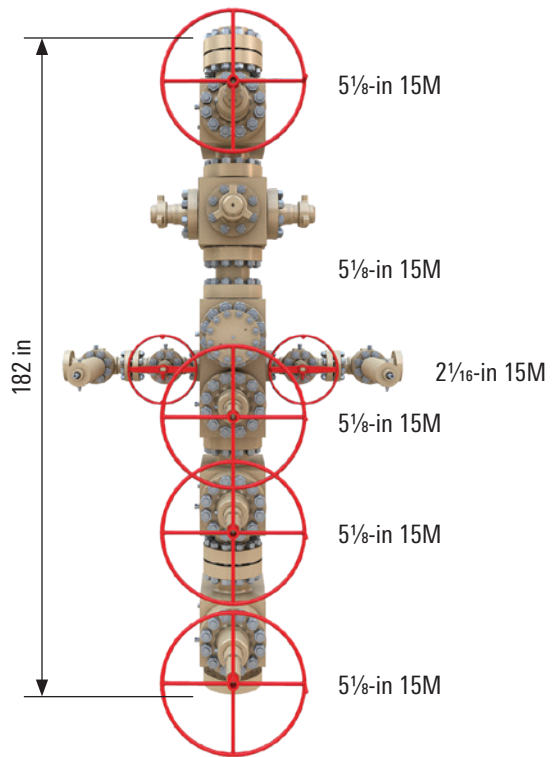

Composite frac tree.

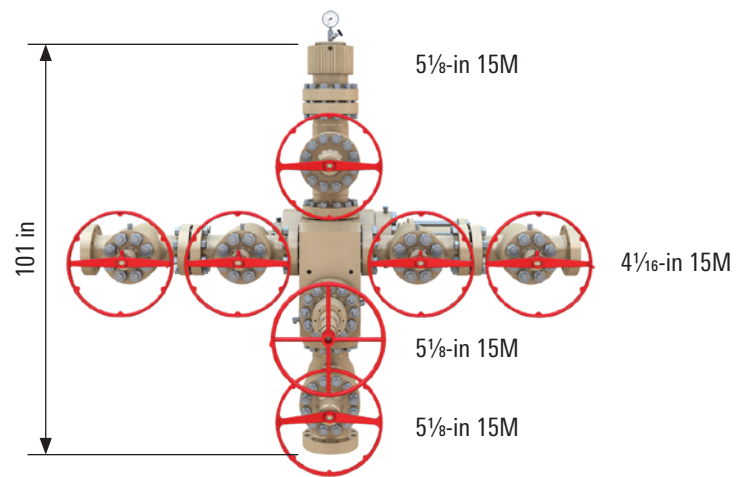

F-T90 horizontal frac tree.

Composite Frac Trees

Designed for hydraulic fracturing pressures up to 15,000 psi, the Cameron composite frac tree houses the master valves, swab valves, and horizontal wing outlets in a single block body, resulting in a significantly shorter assembly—25% shorter than a conventional stacked-valve design. The reduced tree height decreases the bending stress transferred from the goat head to the tree and wellhead connections below. The system enables using a second actuated swab valve, increasing flow control while still maintaining a reasonable height.

Applications

- Fracturing
- High-pressure flow control

Benefits

- Reduces fracturing service footprint
- Protects wellhead integrity through lower tree profile
- Combats erosion with durable components
- Reduces number of connections and potential leak paths

Features

- Fewer connections to make up
- Lower side-to-side bending moments from fracturing fluid delivery
- Pneumatic, hydraulic, or electric actuation
- Integrated cross for flowback and pumpdown
- Internal buffer zone for reduced erosion
- Composite frac valve blocks encase valves in series

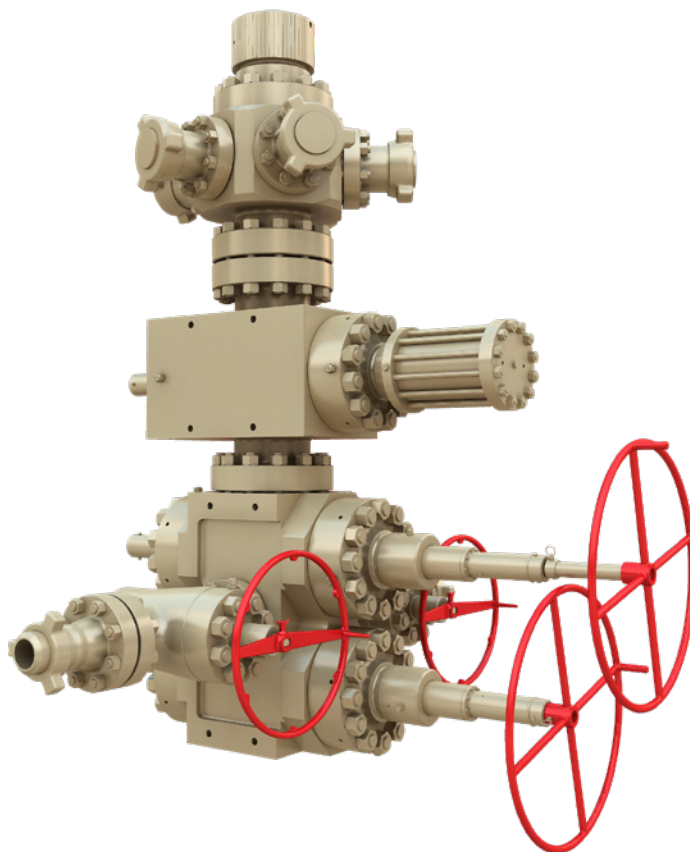

These Cameron composite fracture trees are operating in a seven-well pad in the Fayetteville Shale.

F-T90 Horizontal Frac Tree

The patented F-T90* horizontal frac tree is the industry's first horizontal frac tree and was specifically developed to complement multiwell pad drilling and completions and simultaneous operations. The F-T90 frac tree is approximately 50% shorter and 25% lighter compared with conventional frac trees, resulting in a shorter, more stable, and more easily anchored tree.

Compared with conventional frac trees, the F-T90 frac tree's goat head is located closer to the wellhead. By giving the tree a lower center of gravity, the bending moment is reduced, which protects the wellhead tree interface. The F-T90 frac tree can be operated with pneumatic, hydraulic, or electric actuation and is available in three systems:

- 5½ in and 10,000 psi
- 7¼ in and 10,000 psi
- 5½ in and 15,000 psi.

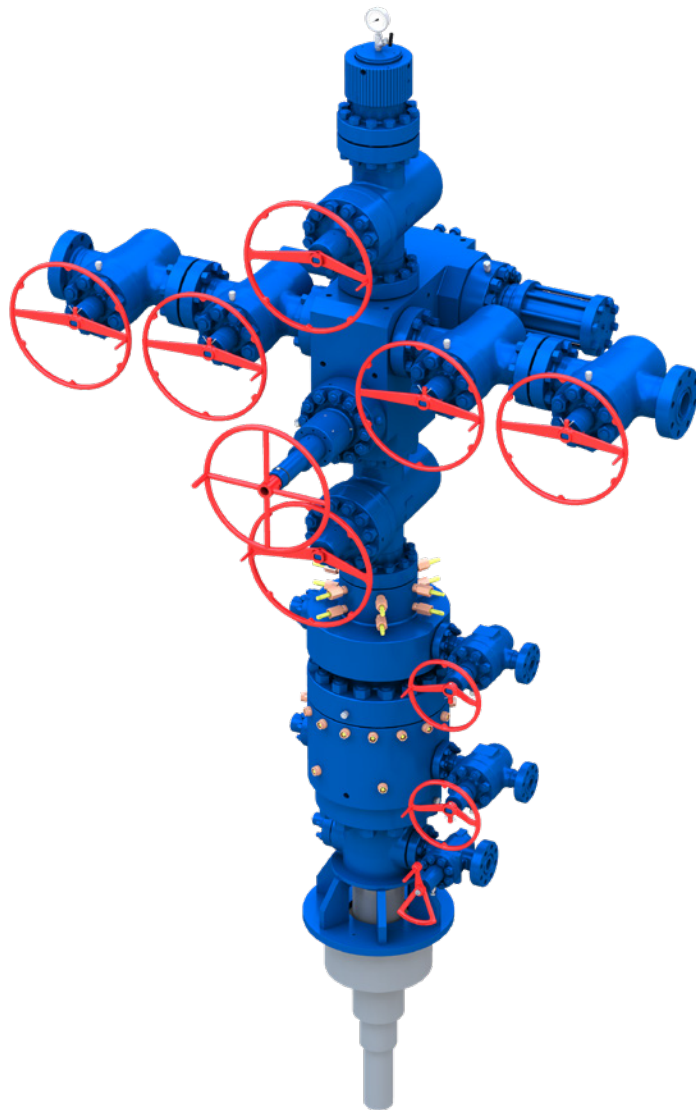

Applications

- Hydraulic fracturing
- Multiwell pad drilling and completions

Advantages

- Solid body block design that yields fewer connections to make up
- Decreased side-to-side bending moments from fracturing fluid delivery
- Same FLS-R* large-bore HP API 6A slab-style gate valve dependability as with conventional Cameron frac tree
- Same top connection as for conventional Cameron frac trees
- Corrosion-resistant-alloy (CRA) inlay design on seat pockets and ring grooves
- Large cavity ports for effective grease and sand evacuation
- Integrated cross for flowback and pumpdown
- Internal buffer zone for reduced erosion
- Lower tree profile that protects wellhead integrity
- Durable components that combat corrosion
- Horizontal design that increases operational safety and efficiency



Built to minimize the bending moments often induced by fracturing operations, the F-T90 tree has a substantially reduced moment arm between the lower tree connection and the point of attachment to the fracturing head.

Frac Manifolds

A frac manifold is an arrangement of flow fittings and valves installed downstream of the fracturing pump output header and upstream of each frac tree being served. Modular and flexible Cameron frac manifolds can be assembled in many configurations. Each leg of the manifold can be aligned vertically, horizontally, or at any angle and will typically have one or two gate valves.

Time spent waiting while an isolation plug is set, perforating guns are positioned and fired in the next zone, the wireline and gun carriers are retrieved, and the lubricator is isolated from the well contributes to costly underutilization of the fracturing crew and equipment. The Cameron frac manifold minimizes idle time for resources and enables their continuous use. Manifold outlets are preconnected to multiple frac tree goat heads, and the manifold output is directed to alternating wells while isolation plugs are set and new fracturing zones are perforated.

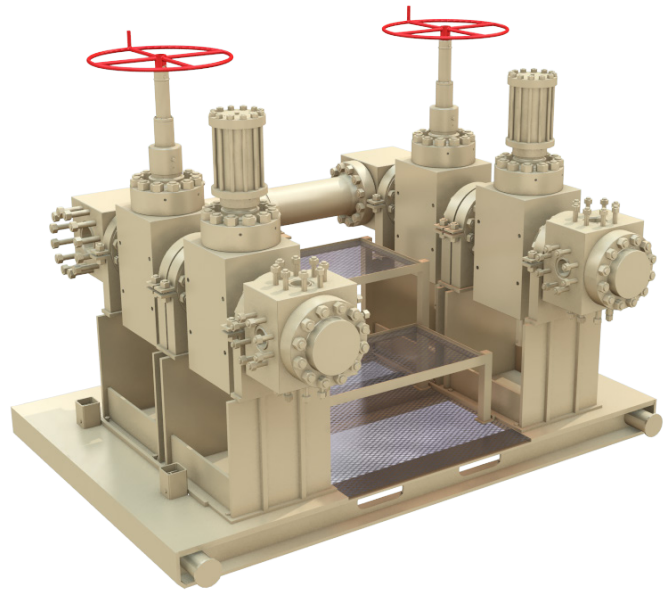

Applications

- Fracturing
- High-pressure flow control
- Simultaneous operations

Benefits

- Improves use of pumping services by enabling continuous operation of multiple wells
- Enhances efficiency by enabling fracturing at one well while running wireline services at another well

Features

- Streamlined manifold design that reduces clutter at well pad
- Hydraulic valves that enable remote control of manifold valves to direct flow as desired
- Manifold design that enables control of fluid flow to multiple wells, eliminating the need for rig-up and rig-down between fracturing stages
- Single inlet for pumping equipment, which reduces the number of flowlines required
- Maximum working pressure of 15,000 psi
- Maximum temperature rating
 - API P (operating range of -20 to 180 degF)
 - API U (room temperature range of 0 to 250 degF)
- Product specification level (PSL): 1, 2, 3
- Nominal bore sizes: 7¹/₁₆ in, 5¹/₈ in, and 4¹/₁₆ in
- Suitability for various well configurations



Monoline technology presents a safer, faster, cleaner alternative to conventional frac iron on multiwell pads, changing the way proppant and fracturing fluid are delivered from the pump spread to the wellbore.

Frac Valves

Gate valves assembled into frac trees and manifolds are exposed to continuous service, flowing and controlling high-pressure, high-volume, abrasive fracturing fluid for long periods of time. The Cameron frac valve offering consists of the widely recognized and field-proven manual FLS-R API 6A gate valve with reliable metal-to-metal seals throughout and the actuated FLS-DA2* API 6A double-acting actuated gate valve designed for quick and easy field maintenance. The FLS-Frac* API 6A slab-style gate valve is a high-quality valve designed specifically for fracturing applications. They are specially fitted with corrosion- and erosion-resistant trim, CRA inlay in seat pockets and ring grooves for added protection, zero-chamfer flowbores to mitigate turbulence that is known to increase erosion, and grease ports for flushing and greasing the valve body cavity.

Applications

- Fracturing
- Frac trees
- Frac manifolds
- Fracturing fluid delivery systems

Benefits

- Reduces exposure to potential erosion
- Maximizes uptime

Features

- Trimmed for maximum corrosion and erosion protection
- CRA inlay in seat pockets and ring grooves that enhances protection
- Zero-chamfer flowbores to mitigate turbulence known to increase erosion
- Two ports for flushing and greasing the valve body cavity

Specifications

Nominal Bore Size, in	Working Pressure, psi	
	10,000	15,000
1 ³ / ₁₆	FLS valve	FLS valve
2 ¹ / ₁₆	FLS-Frac valve	FLS-Frac valve
	FLS-DA2-Frac* API 6A double-acting actuated gate valve	FLS-DA2-Frac valve
2 ⁹ / ₁₆	FLS-Frac valve	FLS-Frac valve
3 ¹ / ₁₆	FLS-Frac valve	FLS-Frac valve
4 ¹ / ₁₆	FLS-Frac valve	–
	FLS-R-Frac valve	FLS-R-Frac valve
	FLS-DA2-Frac valve	FLS-DA2-Frac valve
5 ¹ / ₁₆	FLS-Frac valve	FLS-R-Frac valve
	FLS-DA2-Frac valve	FLS-DA2-Frac valve
7 ¹ / ₁₆	FLS-Frac valve	FLS-R-Frac valve
	FLS-DA2-Frac valve	FLS-DA2-Frac valve



Cameron gate valves in frac trees and manifolds can reliably flow and control high-pressure, high-volume, erosive, corrosive, and sometimes sour fracturing and flowback fluids for days.

Monoline Flanged-Connection Fracturing Fluid Delivery Technology

Monoline flanged-connection fracturing fluid delivery technology presents a safer, faster, cleaner alternative to conventional frac iron on multiwell pads, changing the way proppant and fracturing fluid are delivered from the pump spread to the wellbore. The technology is faster to mobilize and increases fracturing uptime while requiring fewer technicians on location. It simplifies the rig-up procedure by arriving on location preassembled; installation time is reduced by more than 60%.

The technology eliminates the potential to mismatch equipment, simplifies hookup, eliminates multiple flowlines, and reduces the number of connections or potential leak paths by up to 75%, thus decreasing HSE risk (conventional systems have 4–8 lines per well with 8–14 connections per line).

The single-line technology adheres to API 6A standards and comprises straight high-pressure pipe segments, 90° elbows, and swivel flanges that are bolted together. Replacing multiple hammer unions with far fewer, measurably torqued flanged connections with metal sealing gaskets promotes a higher level of system integrity, safety, and reliability and lower NPT. The technology enables the full 3° of freedom needed to accommodate alignment between the frac tree and frac manifold.



Monoline technology offers a larger diameter for increased flow rate, mitigating erosive fluid velocities; a streamlined design to facilitate installation and reduce the bends in the flow path; and a safer connection that reduces failure points.

Applications

- Fracturing

Benefits

- Eliminates nonsturdy, unsafe connections
- Minimizes potential leak paths and failure points
- Reduces wellsite footprint
- Improves structural integrity of the entire wellhead
- Eliminates potential to mismatch equipment
- Reduces assembly, rig-up, and rig-down times
- Requires fewer technicians on location
- Replaces multiple hammer unions through design that includes significantly fewer measurably torqued flanged connections with metal sealing gaskets
- Improves operational efficiency by arriving preassembled and enabling installation outside the critical path of operations

Features

- API 6A flanged connection with a single, dedicated flowline
- Controlled bolted connections that promote a higher level of system integrity and safety
- Articulation using swivel flanges to make up for deviations in distance between frac tree and manifold
- BX-type ring gaskets
- Use of API 6A flanged connections with conventional tools and known recommended torque values
- Fit for service in demanding service conditions

FracGUARD Isolation Head

The FracGUARD* isolation head enables simultaneous operations on the same well without breaking connections, enabling coiled tubing and wireline tools to be run during stimulation. We also offer pipe, manifold, and personnel for fluid and pressure management.

Applications

- Fracturing
- Refracturing
- Coiled tubing operations
- Fiber-optic operations

Benefits

- Allows the fracturing components to withstand high-volume fracturing jobs while countering corrosive and erosive effects
- Enables high-volume flow rates ideal for popping the toe

Features

- Industry-leading flow area between the frac head ID and the isolation sleeve OD
- Function as a barrier between the fluid entry ports of the frac head and the tooling OD

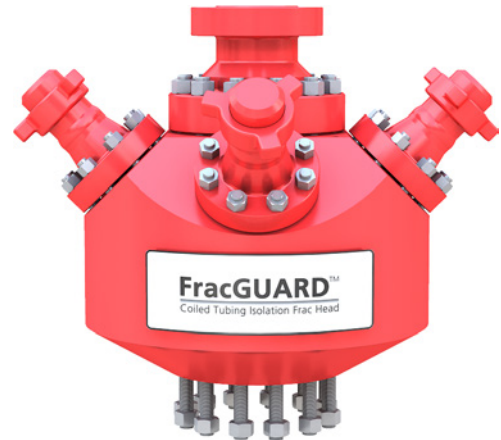

FracGUARD isolation head.

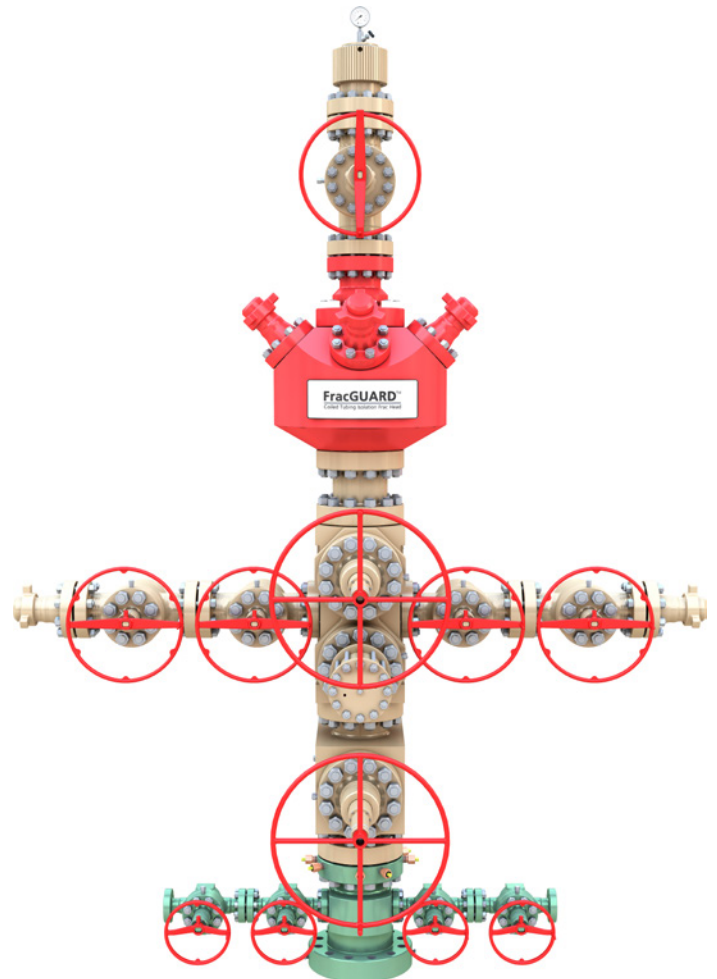

The FracGUARD frac head and the Cameron composite block frac tree are ideally suited to CT annular fracturing operations.

CAMFRAC Isolation System

The CAMFRAC* isolation system is designed to accommodate fracturing pressures in excess of the upper flange and outlet pressure ratings of a type C tubing spool. The fracturing sleeve protects the bore of the spool from high pressure and erosion, and enhanced connection technology enables a fracturing pressure of 10,000 psi using a 5,000-psi-rated tubing spool and 15,000 psi using a 10,000-psi-rated tubing spool. The system is available for 7 $\frac{1}{16}$ -in type C tubing spool profiles, and it has full opening to both 4 $\frac{1}{2}$ - and 5 $\frac{1}{2}$ -in production casings.

Applications

- Fracturing

Benefits

- Eliminates the need to kill the well
- Eliminates the need for wireline unit
- Mitigates erosion from high-pressure fracturing slurry
- Leverages existing tubing spool inventory

Features

- Enhanced connection technology that enables fracturing operations up to 10,000 psi using 5,000-psi-rated tubing spools and up to 15,000 psi using 10,000-psi-rated tubing spools
- Solid, single-piece design that is easy to install and retrieve and isolates the flange neck, side outlets, and internal bowl from fracturing pressure
- Simple lockscrew holddown
- No requirement for interface with secondary seal bushing; quick installation through 7 $\frac{1}{16}$ -in tree
- H- or latch-type BPV preparation, eliminating the need for wireline unit
- Full opening to both 4 $\frac{1}{2}$ -in and 5 $\frac{1}{2}$ -in production casing

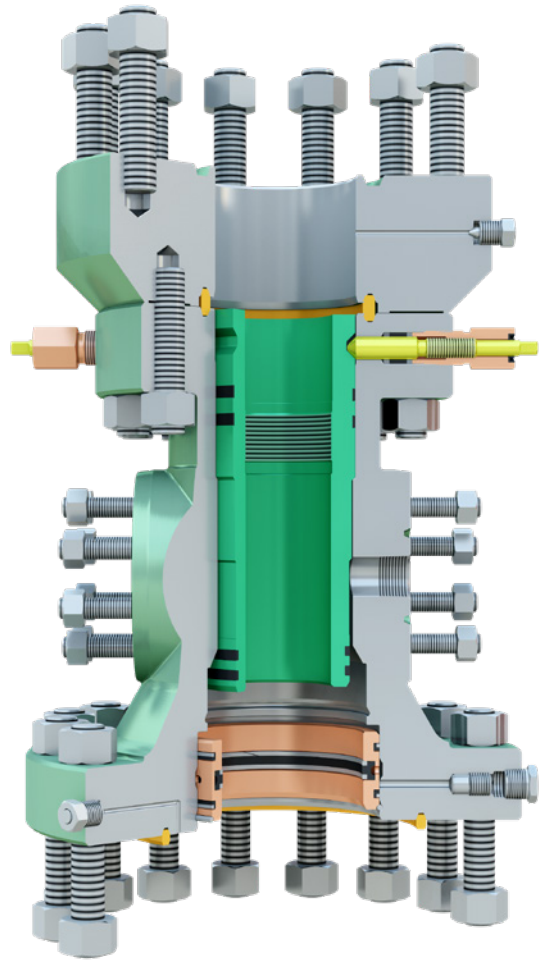

Fullbore Completion Tubing Equipment (FBCTE)

Fully rated tubing spools provide an alternative to the use of bore isolation tools. When fullbore access is required, Cameron can provide a fullbore extension of the standard completion tubing equipment (SCTE). The FBCTE is a hydraulic fracturing tubing spool that contains a set of type E lockscrew assemblies to provide the initial landing shoulder and retain the tubing hanger.

Applications

- Fracturing
- Tubing completions

Benefits

- Improves cost effectiveness and reduces overall footprint by enabling the use of smaller frac trees
- Eliminates excess equipment and onsite service technicians required to run bore isolation tools

Features

- Tubing hanger that can be safely landed through the frac tree
- Easy conversion from fracturing and flowback mode to production mode without killing the well
- Ability to handle severe hydraulic fracturing pressures up to 15,000 psi
- Accommodation of fracturing through the tubing spool without an isolation device
- Availability with 4 $\frac{1}{8}$ -in and 5 $\frac{1}{8}$ -in nominal sizes up to 15,000 psi
- Availability with single and double T seals, NX bushing, and CANH seal configurations
- FBCTE-style tubing hanger that provides a positive annular seal with minimal lockscrew torque
- Type N lockscrew with graphite packing, which positively prevents ingress of wellbore fluids and contaminants into actuation mechanism

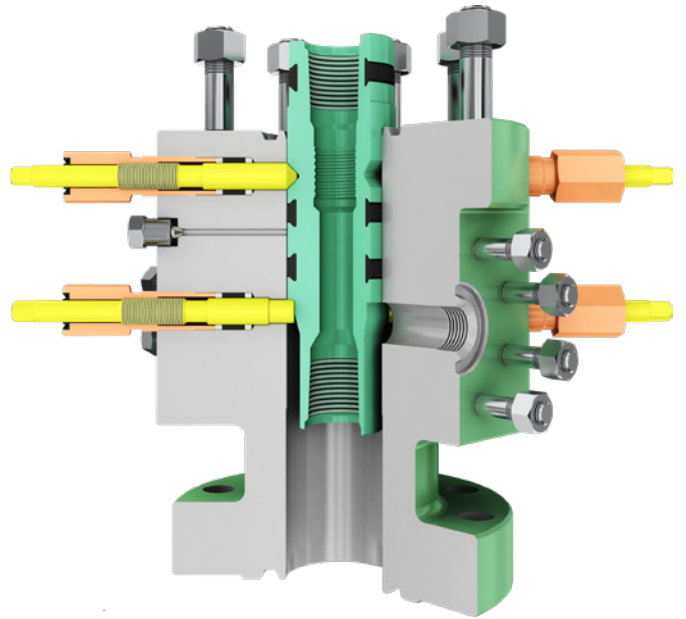

Standard Completion Tubing Equipment (SCTE)

Fully rated tubing spools provide an alternative to the use of bore isolation tools. The SCTE is a hydraulic fracturing tubing spool designed to hold pressures up to 15,000 psi. It reduces both the equipment required onsite and rig-up time. Safety of operations is enhanced through the elimination of bore isolation tools.

Applications

- Fracturing
- Tubing completions

Benefits

- Improves cost effectiveness and reduces overall footprint by enabling the use of smaller frac trees
- Easily converts from fracturing and flowback mode to production mode without killing the well
- Eliminates crane, excess equipment, and onsite service technicians required to run bore isolation tools

Features

- Ability to handle severe hydraulic fracturing pressures up to 20,000 psi
- Enables fracturing through the tubing spool without any isolation device
- Availability with 4 $\frac{1}{16}$ -in and 5 $\frac{1}{8}$ -in nominal sizes up to 15,000-psi working pressure
- Availability with single and double T seals, NX bushing, and CANH seal configurations
- Availability with screwed, flanged, and studded configuration
- Nested SCTE-style tubing hanger provides a positive annular seal with minimal lockscrew torque
- Type N lockscrew with graphic packing, which positively prevents ingress of wellbore fluids and contaminants into actuation mechanism
- Type H BPV profile in tubing hanger

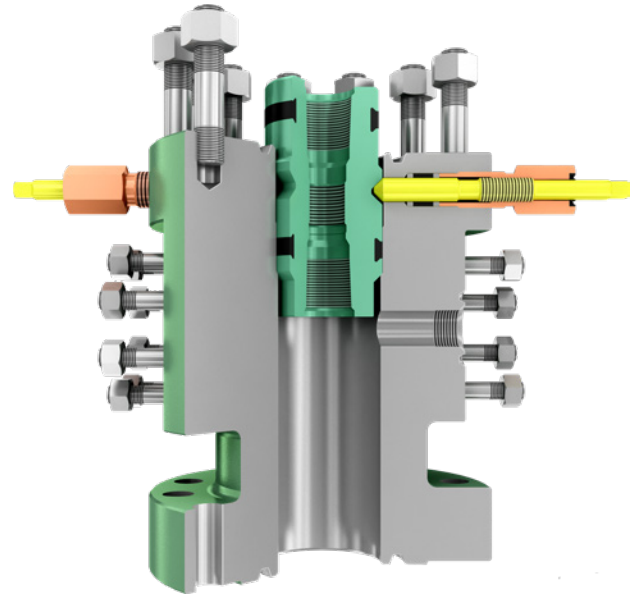

Flowback and Well Testing

Cameron provides flowback and well testing services across all North American basins, with the knowledge, equipment, and procedures to suit unique operating conditions (pressure, temperature, flow rates, and fluids) and varying regulatory requirements. When these services are provided as part of the CAMShale* fracturing fluid delivery and flowback service, multiskilled technicians are on site from the time the fracturing fluid delivery system is rigged up, reducing logistics demands and crew size.

Flowback and well testing

Plug catchers	36
Sand separators	36
Gate valve choke manifolds	37
Plug valve choke manifolds	37
Well test separators	38
Emergency shutdown (ESD) valves	38
Indirect heaters	39
Hydraulic choke control trailers	39
Flare systems	40



Plug Catchers

Cameron plug catchers support well cleanup by filtering isolation plug remnants and fragments of casing, cement, and loose rock from the perforation area.

Advantages

- Single barrel with bypass or dual barrel
- Elimination of potential equipment damage or blockage by removing large solid debris immediately after the fracture stack
- Working pressures from 10,000 to 15,000 psi
- Sweet or sour service
- Plug-valve- or gate-valve-based design
- Availability of hydraulically controlled dumping option

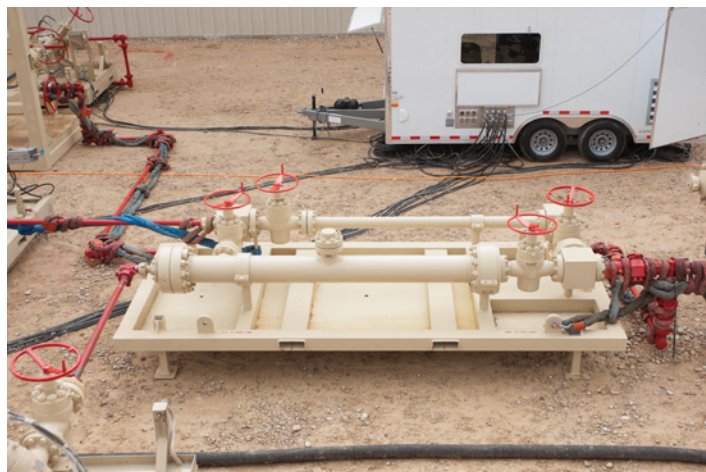

Cameron plug catchers eliminate debris-related blockages and equipment damage.

Sand Separators

Sand separators remove sand and other small solids from flowback fluids, the production stream, or both. Cameron gravity-based systems use centrifugal force to spin solids out of the wellstream.

Advantages

- Working pressures of 5,000, 10,000, and 15,000 psi
- ASME or API compliant design
- Sour service ready
- Full wellhead pressure ratings (based on selection)
- On-skid bypass piping included
- Automatic dumping option available for remote operations



Cameron sand separators minimize solids in flowback fluids and production streams.

Gate Valve Choke Manifolds

Hydraulically actuated gate valve choke manifolds are used for remote control of downstream pressure and volume during flowback and well testing. Multiple configurations are available, including dual-choke manifolds with bypass.

Advantages

- Working pressure rating up to 15,000 psi
- Skid-mounted leveling jacks included
- Manual and automatic manifold configurations available

Plug Valve Choke Manifolds

Manual quarter-turn Cameron plug valve choke manifolds are used to control downstream pressure and volume during flowback and well testing.

Advantages

- Standard service plug valve working pressures up to 15,000 psi
- Sour-service plug valve working pressures up to 10,000 psi
- Manifold design that maximizes pressure isolation and control
- Skid-mounted design with manual bypass configured in on-skid piping
- Quarter-turn manual actuation for simple operation
- Gear-operator versions available



Plug valve choke manifolds regulate downstream pressure and volume accurately.

Well Test Separators

Cameron well test separators use low- or high-working-pressure vessels to separate oil, water, gas, and sometimes solids (sand) into individual streams for more accurate measurement and discharge control.

Advantages

- Working pressure ratings from 500- to 2,000-psi gauge pressure
- Skid-mounted or trailer-integrated designs
- NACE compliance
- Two-, three-, or four-phase separator test units
- Horizontal or vertical orientation
- On-skid piping and instrumentation
- Dedicated measurement for gas, oil, and water
- Electronic flowmeter for accurate, real-time reporting



Low- and high-working-pressure vessels are used to separate oil, water, gas, and sometimes solids (sand) into individual streams for more accurate measurement and discharge control.

Emergency Shutdown (ESD) Valves

ESD valves are used to isolate pressure and flow from a particular source during an overpressure situation. Cameron ESD valves are integrated into the design of the well testing equipment and can be installed inline to any location upstream of the testing units.

Advantages

- Integrated design that enables control of overpressure, high liquid level, or both
- Pneumatic operation
- Upstream installation flexibility through connective design



Integrated design of ESD valves ensures effective, reliable emergency shutdown.

Indirect Heaters

Heaters are used in almost every phase of oil production and processing. In gas applications, where lower flowing or ambient temperatures are present, production challenges exist when a pressure differential is anticipated. These conditions can lead to the formation of hydrates, which can cause damage to equipment and lower overall separation efficiency. In these cases, Cameron recommends the use of an indirect heater to raise the inlet process temperature and control the pressure drop prior to separation.

Advantages

- Skid- or trailer-mounted design with on-board piping and instrumentation
- Process coils that are rated up to 15,000 psi on some systems
- Efficient heat transfer using a bath fluid that features a glycol-water mix and can achieve outlet process temperatures of up to 180 degF
- Higher process temperatures that aid in hydrate prevention
- Increased separation efficiency



Cameron well test separators feature on-skid piping and instrumentation for simpler maintenance.

Hydraulic Choke Control Trailers

Serving as a mobile platform to control valve and choke position and operation, Cameron hydraulic choke control trailers provide data acquisition functionality, including temperature and pressure monitoring of the entire site. They include four-station (or more) hydraulic control and ESD safety system control. They can also be linked to an electronic flowmeter on the test separator to provide visualization of pressures, temperatures, and flow rates. Wired and wireless data transmission is available.



Our hydraulic choke control trailers offer greater functionality for temperature and pressure data acquisition and monitoring.

Flare Systems

Equipped with a continuous autoignition system, Cameron flare systems are easily relocated between sites.

Advantages

- Use based on customer's export strategy
- Easy relocation between sites



Flare systems are available in 3-, 4- or 6-in-diameter stacks with multiple heights.

Radio-frequency identification (RFID) tagging is at the core of our asset management initiative.

Support Services

Cameron service technicians provide total support in the field or in the shop 24 hours a day, 365 days a year. Personnel are highly skilled in providing equipment installation and testing, making field repairs and performing maintenance on your equipment.

Wellsite services

- Wellhead rental and sales
- Frac tree rental and sales
- Installation and testing
- Annulus and casing testing
- Valve greasing and maintenance
- Repair, refurbishment, and maintenance of all major fracturing and wellhead equipment
- Installation of BPVs, tree test plugs, and valve removal (VR) plugs
- Field inspection and general conditioning





API 6A Gate Valves

API 6A Gate Valves

Over the course of the last century, numerous gate valve design genres have been developed for use in the oil and gas industry.

Designs that have commonly been used to control fluid flow through production trees and flowlines include expanding-, wedge-, and slab-style gate valves.

After a careful review of these existing designs, Cameron engineers have selected the best-suited features for development and implementation into our API 6A gate valve product line. Our valve line includes some of the world’s most successful and widely recognized gate valves.

Expanding-style gate valves	43
Wedge-style gate valves	43
Slab-style gate valves	44

API 6A Gate Valves

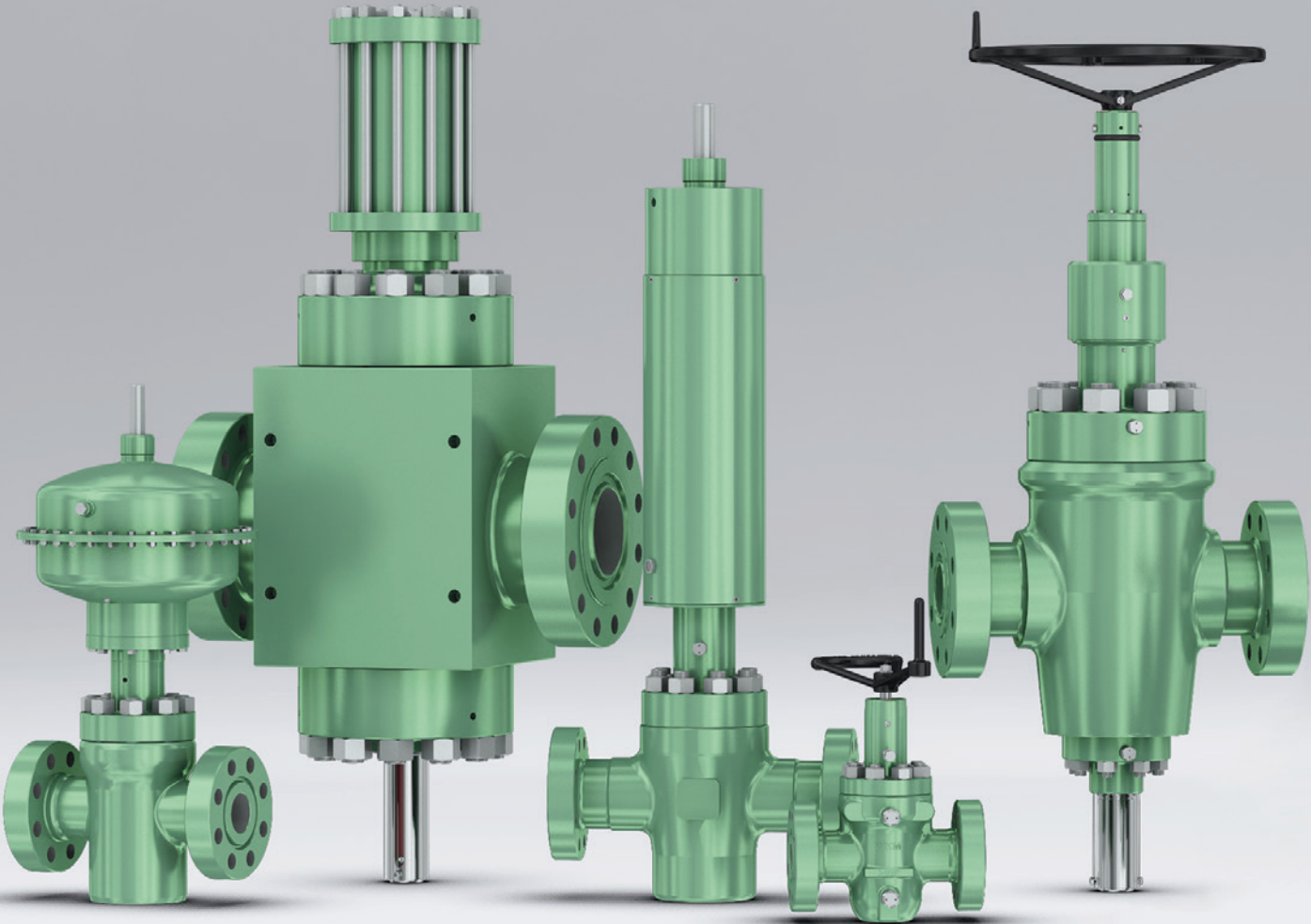

FLS pneumatic valve.

FLS-DA2 valve.

FLS hydraulic valve.

M-HT valve.

FLS-R valve.

Expanding-Style Gate Valves

The defining feature of the expanding gate design is its high mechanical seating force generated by applying torque to the handwheel in the full open and full closed positions, making it a favorite of many operators for some applications. Cameron expanding gate solutions include

- M Pow-R-Seal* API 6A expanding gate valve
- M-HT* API 6A HT expanding gate valve.

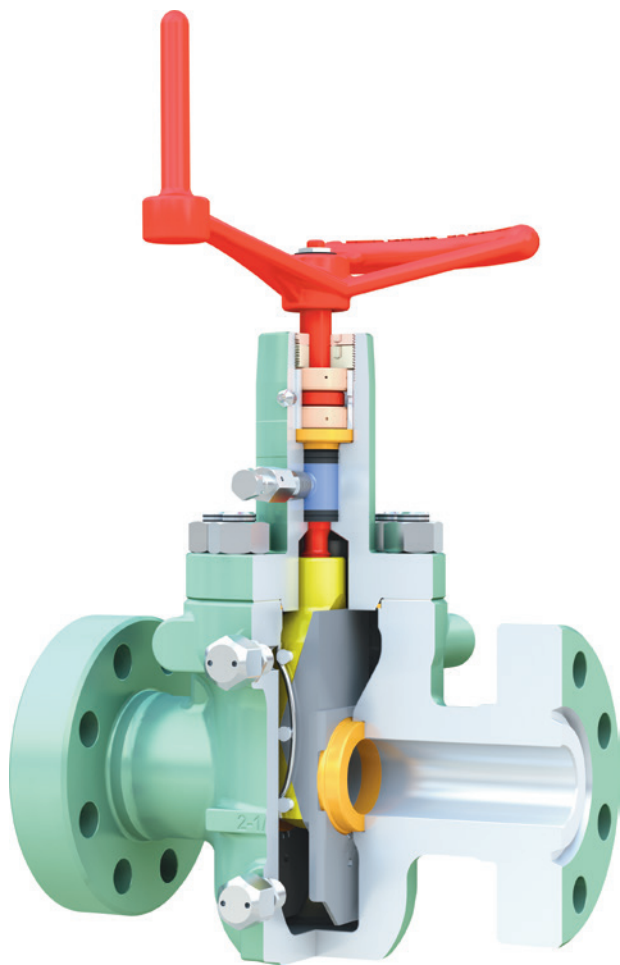

M Pow-R-Seal API 6A expanding gate valve.

Wedge-Style Gate Valves

A dual-seat test saves operational time. Having two slab gates in the same valve cavity allows a flowline seal test to be performed simultaneously in both flow directions. The FLS-S gate valve model was designed for API 6A applications with all features of the FLS valve, such as forged construction, metal-to-metal sealing, slab-style gate, stem seal, and seat design. Bidirectional design provides flow direction versatility and increased service life.

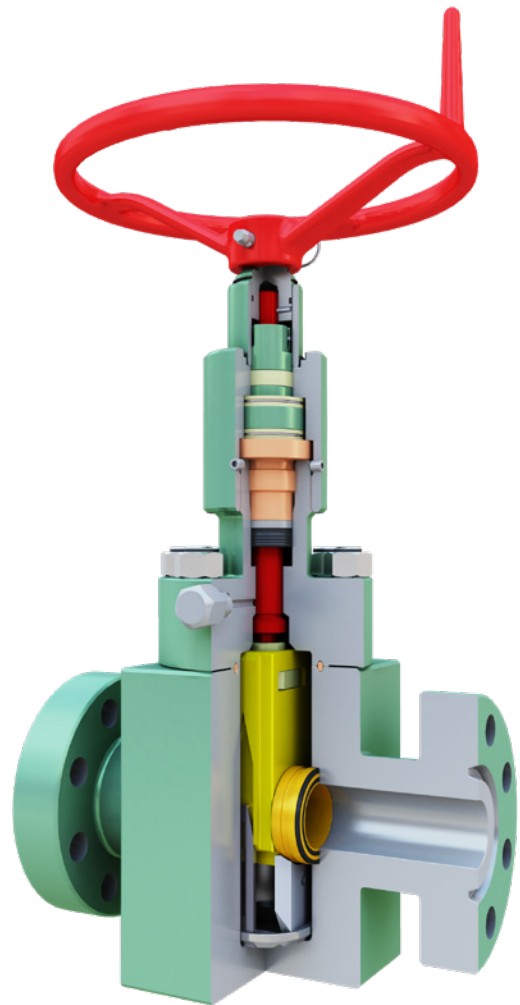

FLS-S API 6A gate valve.

Slab-Style Gate Valves

Most Cameron gate valve designs use a solid, single-piece slab gate. The use of a slab-style gate simplifies the design, resulting in a valve that is rugged yet easy to assemble and maintain.

Included in this category are

- FLS API 6A gate valve
- FLS-R API 6A gate valve.

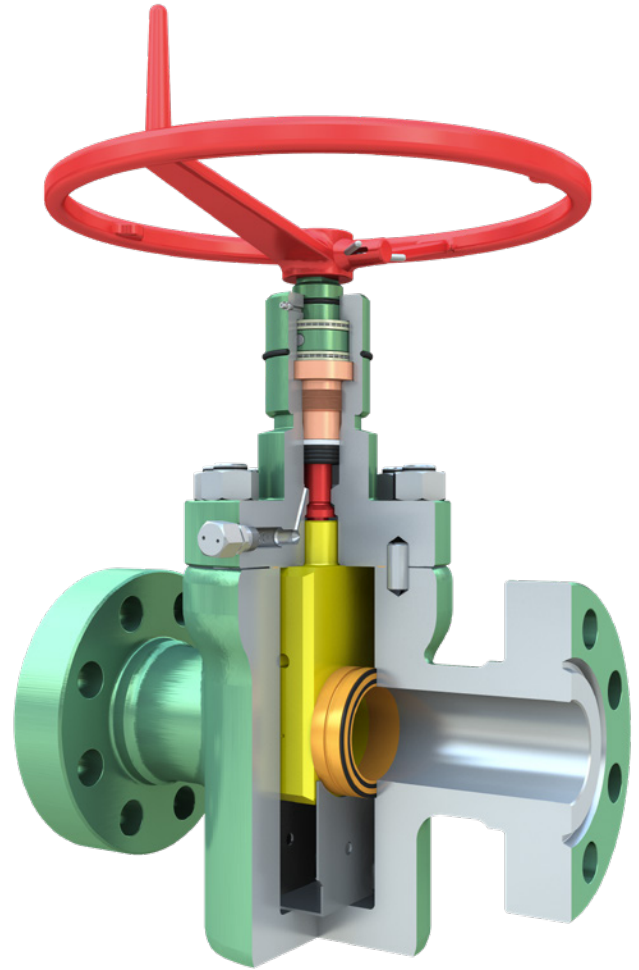

FLS API 6A slab-style gate valve.

Size and Pressure Availability

Nominal Bore Size, in	Working Pressure, psi [MPa]						
	2,000 [13.8]	3,000 [20.7]	5,000 [34.5]	10,000 [68.9]	15,000 [103.4]	20,000 [138]	30,000 [206.8] [†]
1 ³ / ₁₆	–	–	–	FLS valve	FLS valve	FLS valve	FLS or FLS-R [‡] valve
2 ¹ / ₁₆	FLS, or M series valve	FLS, FLS-S* API 6A split slab-style gate valve, or M series valve	FLS, FLS-S, or M series valve	FLS or FLS-S valve	FLS or FLS-S valve	FLS valve	–
2 ⁹ / ₁₆	FLS, or M series valve	FLS, FLS-S, or M series valve	FLS, FLS-S, or M series valve	FLS or FLS-S valve	FLS or FLS-S valve	FLS valve	FLS or FLS-R [‡] valve
3 ¹ / ₁₆	–	FLS-S valve	FLS-S valve	FLS or FLS-S valve	FLS or FLS-S valve	FLS or FLS-R [‡] valve	–
3 ¹ / ₈	FLS, or M series valve	FLS, FLS-S, or M series valve	FLS, FLS-S, or M series valve	FLS-S valve	FLS-S valve	–	–
4 ¹ / ₁₆	–	FLS-S valve	FLS-S valve	FLS or FLS-S valve	FLS, FLS-R, or FLS-S valve	–	FLS or FLS-R [‡] valve
4 ¹ / ₈	FLS valve	FLS	FLS valve	–	–	–	–
5 ¹ / ₁₆	FLS valve	FLS or FLS-S valve	FLS or FLS-S valve	FLS, FLS-R, or FLS-S	FLS, FLS-R [‡] , FLS-S, or FLS-RS [‡] valve	–	–
6 ¹ / ₈	FLS valve	FLS valve	FLS valve	–	–	–	–
6 ³ / ₁₆	FLS valve	FLS or FLS-S valve	FLS or FLS-S valve	FLS, FLS-R, FLS-S, or FLS-RS [‡] valve	FLS, FLS-R [‡] , FLS-S, or FLS-RS [‡] valve	–	–
7 ¹ / ₁₆	–	FLS-S valve	FLS or FLS-S valve	FLS, FLS-R, FLS-S, or FLS-RS [‡] valve	FLS, FLS-R [‡] , FLS-S, or FLS-RS [‡] valve	–	–
9	–	FLS-S valve	FLS, FLS-R, FLS-S, or FLS-RS* large-bore HP API 6A split slab-style gate valve [†]	FLS, FLS-R, [‡] FLS-S, or FLS-RS [‡] valve	FLS, FLS-R [‡] , FLS-S, or FLS-RS [‡] valve	–	–
11	–	–	FLS or FLS-R valve	–	–	–	–

FLS gate valves may be manual or actuated unless otherwise noted.

[†]This working pressure is not currently covered in API 6A.

[‡]FLS gate valves for this size and pressure combination are power actuated.

For FLS and FLS-R gate valves, this chart represents typical valves for API Material Classes AA, BB, CC, DD, EE, FF, and HH; Temperature Ratings K, L, P, S, T, U, and V; and Product Specification Levels 1, 2, 3, 3G, and 4. For other designs, please contact Cameron.

For M series gate valves, this chart represents typical valves for API Material Classes AA, BB, CC, DD, EE, and FF; Temperature Ratings K, L, P, S, T, U, and V; and Product Specification Levels 1 and 2. For other designs, please contact Cameron.



A team of experienced Cameron technicians performs all installations.



API 6A Actuators

Cameron offers a broad portfolio of actuators for API 6A valve applications. When incorporated into a safety system, these actuators protect the environment and equipment by shutting in the well when most needed. We also provide a comprehensive line of accessories, such as bonnets and stems, for interfacing with gate valves.

Pneumatic diaphragm actuators	48
Pneumatic piston actuators	49
Hydraulic actuators	50
Hydraulic wireline-cutting actuators	51

Pneumatic Diaphragm Actuators

Cameron pneumatic diaphragm actuators are designed to be used with most manufacturers' gate valves. The simple design and operating principle make these actuators inherently trouble free. Recommended when instrument air is available, the pneumatic diaphragm series is reliable and cost effective.

Applications

- Valve operations
- Sour service

Advantages

- Strong diaphragm material for longer service life and higher operating temperatures
- Stackable actuator designs for control of larger valves without increasing the OD
- Coated nonstainless components for longer wear life and optimized corrosion resistance
- Standard ½-in NPT supply and exhaust port that reduces opening and closing times and minimizes possibility of restriction
- Top shaft seal for extended seal life and easy removal for seal inspection and replacement
- Bonnet connection for easy orientation of actuator
- No nonstandard tools required for installation, removal, or maintenance, significantly reducing downtime
- Spring preloads that promote safety and simplify and expedite assembly and disassembly
- Stainless steel spacers installed during initial manufacturing that serve as a secondary means of setting the valve drift

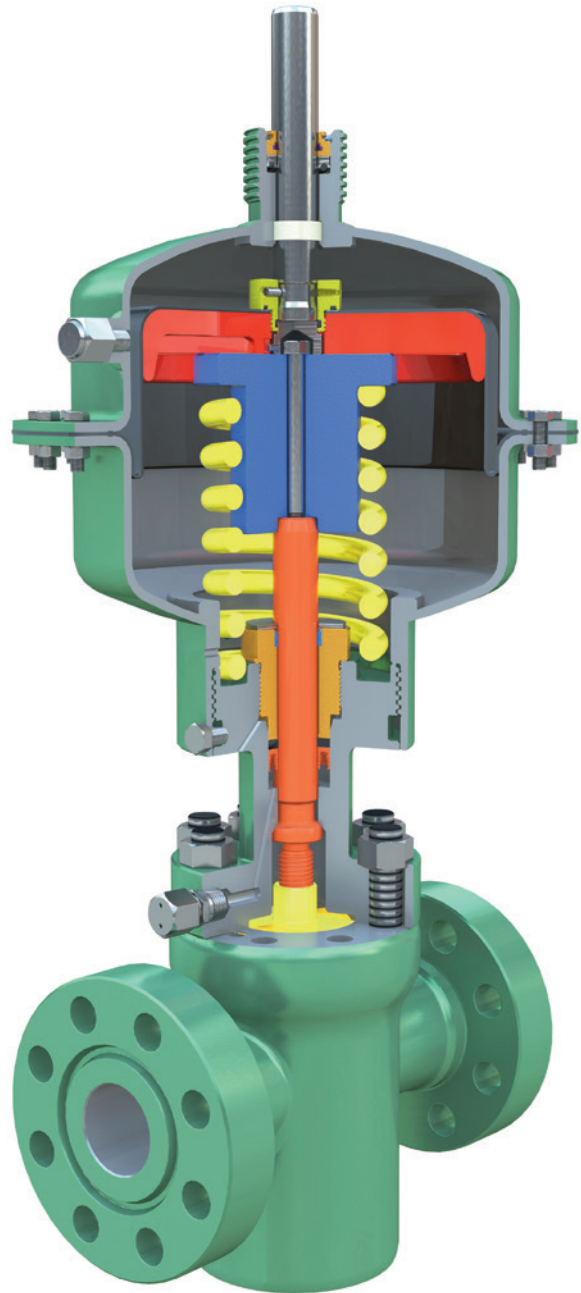

Pneumatic Piston Actuators

The Cameron pneumatic piston series of actuators is designed to be used with most manufacturers' gate valves. The simple design and operating principle make these actuators inherently trouble free. Recommended when instrument air is available, the pneumatic piston series offers a reliable and cost-effective option when a robust actuator is required.

Applications

- Valve operations
- Sour service

Advantages

- Easily removable piston that enables quick seal inspection and replacement
- Coated nonstainless components for longer wear life and optimized corrosion resistance
- Standard ½-in NPT supply and exhaust port that reduces opening and closing times and minimizes possibility of restriction
- Top shaft seal for extended seal life and easy removal for seal inspection and replacement
- Bonnet connection for easy orientation of actuator
- No nonstandard tools required for installation, removal, or maintenance, significantly reducing downtime
- Spring preloads that promote safety and simplify and expedite assembly and disassembly
- Stainless steel spacers installed during initial manufacturing that serve as a secondary means of setting the valve drift

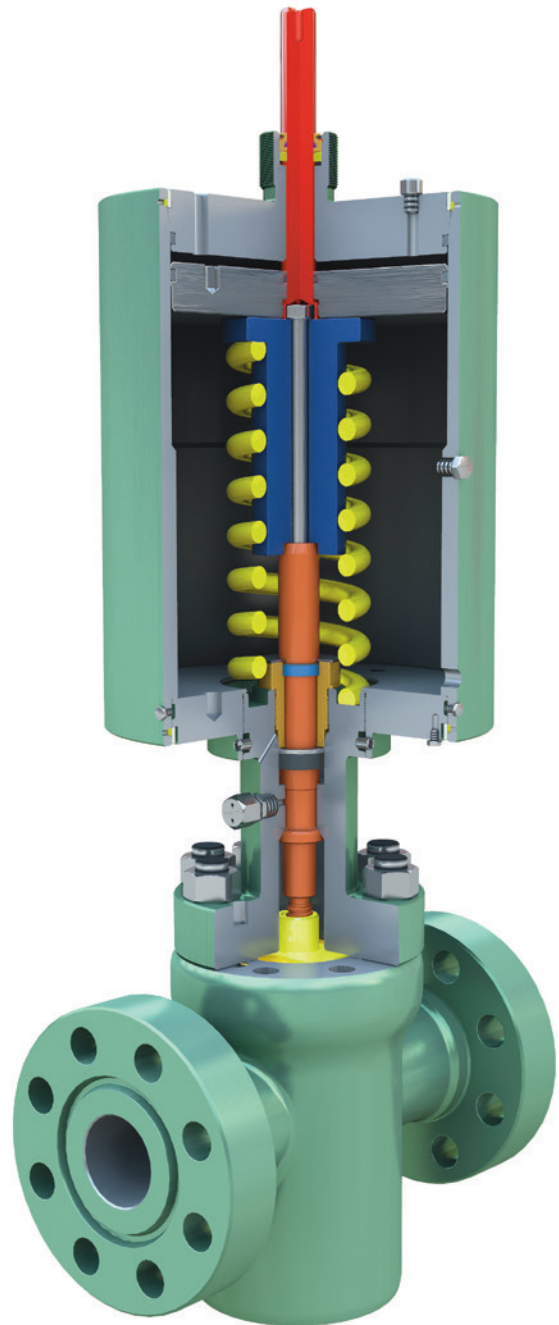

Hydraulic Actuators

Cameron robust API 6A hydraulic actuators make large-bore and high-pressure valve applications inherently trouble free. They are recommended for such operations with high thrust applications when there is no gas source or when the well gas is too sour. Our hydraulic product line offers a reliable and robust hydraulic solution that can be installed in harsh and remote environments where regular maintenance may prove difficult.

Applications

- High-pressure valve operations
- Large-bore wells
- Sour service

Advantages

- Special actuator head that incorporates single-piston design featuring top-loaded seal
- Reduced swept volume requirements
- Housing of all pressure-containing components in the actuator head
- Rising stem (RS) and nonrising stem (NRS) models
- Coated nonstainless components for longer wear life and optimized corrosion resistance
- Standard ½-in NPT supply and exhaust port that reduces opening and closing times and minimizes possibility of restriction
- Full utilization of Cameron advanced valve stem seal designs
- No nonstandard tools required for installation, removal, or maintenance, significantly reducing downtime
- Spring preloads that promote safety and simplify and expedite assembly and disassembly
- Stainless steel spacers installed during initial manufacturing that serve as a secondary means of setting the valve drift

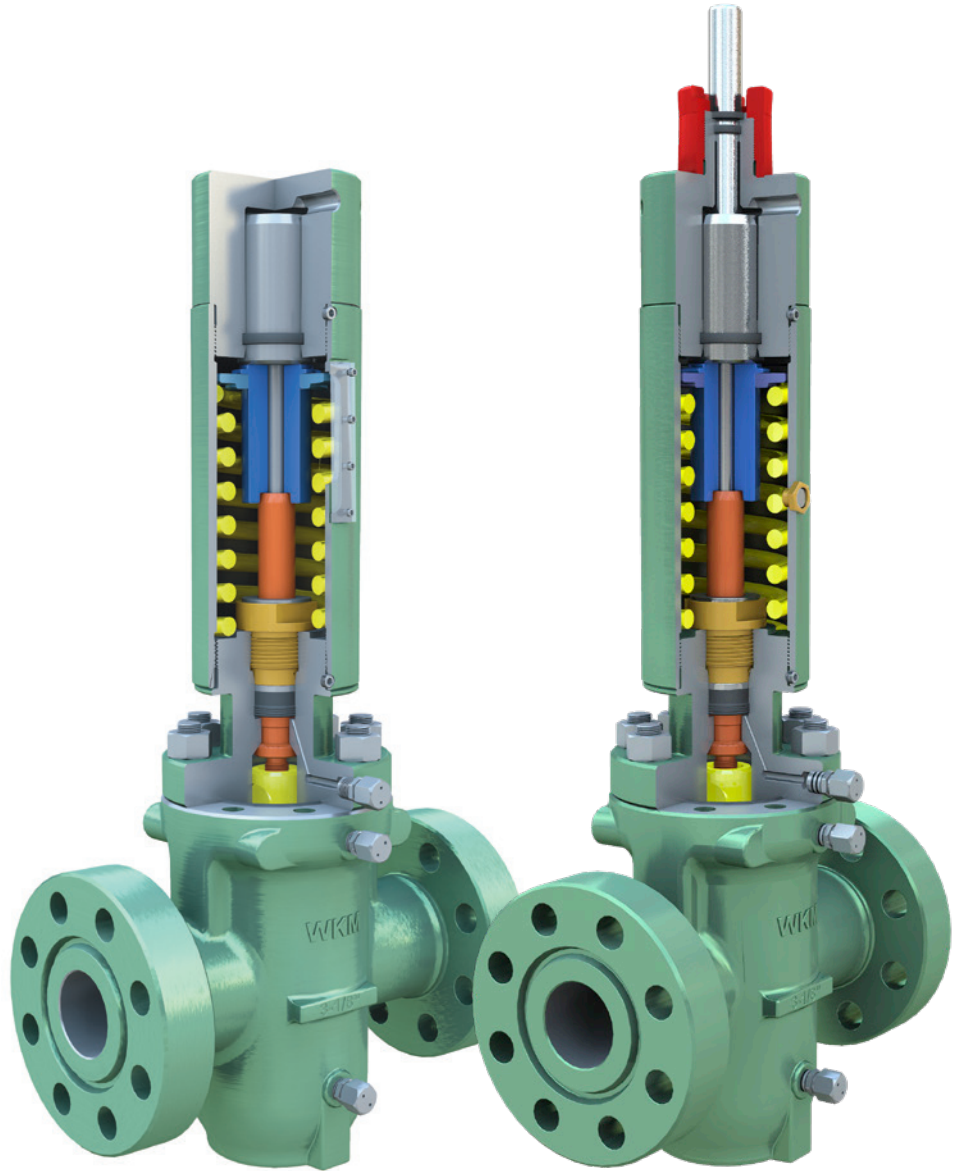

Nonrising-stem hydraulic actuator.

Rising-stem hydraulic actuator.

Hydraulic Wireline-Cutting Actuators

The hydraulic wireline-cutting actuator is used primarily during wireline operations. This actuator operates as a conventional actuator to open or close a gate valve during normal production periods; it also becomes a primary safety device during wireline operations by ensuring that the well can still be shut in should an emergency occur. This is possible because of the springs, which exert high forces to cut the wireline cable, braided line, or coiled tubing. Cameron's hydraulic wireline-cutting actuators offer a reliable and robust design that can be installed in harsh and remote environments.

Applications

- Operations that include wireline

Advantages

- Special actuator head that incorporates single-piston design featuring top-loaded seal
- Reduced swept volume requirements
- Housing of all pressure-containing components in the actuator head
- RS and NRS models
- Coated nonstainless components for longer wear life and optimized corrosion resistance
- Standard ½-in NPT supply and exhaust port that reduces opening and closing times and minimizes possibility of restriction
- Full utilization of Cameron advanced valve stem seal designs
- No nonstandard tools required for installation, removal, or maintenance, significantly reducing downtime
- Spring preloads that promote safety and simplify and expedite assembly and disassembly
- Stainless steel spacers installed during initial manufacturing that serve as a secondary means of setting the valve drift

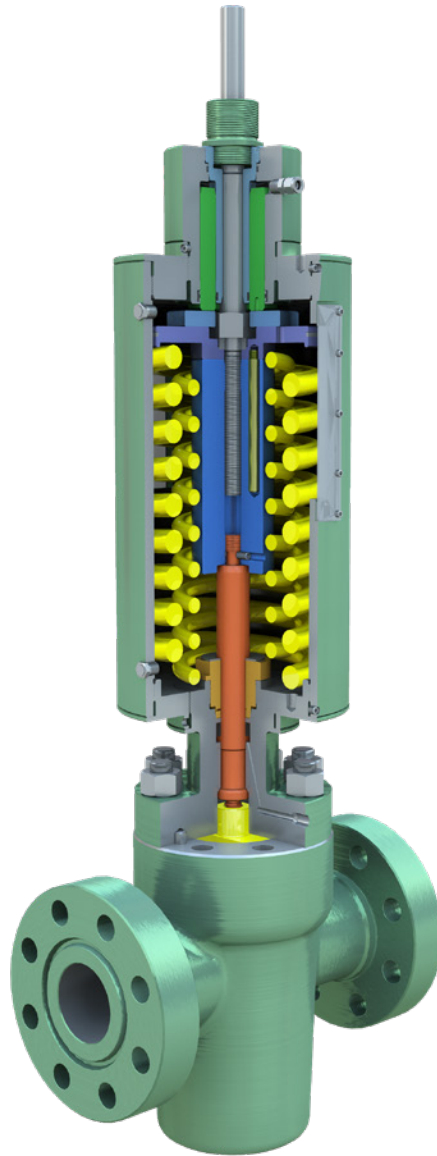

RS hydraulic wireline-cutting actuator.



NRS hydraulic wireline-cutting actuator.

Cameron offers a broad portfolio of actuators for both API 6A and 6D valve applications.





Production

With proven functionality and dependability in a compact envelope, Cameron production equipment helps customers achieve streamlined operations, higher uptime, and decreased overall risk — no matter the environment.

Safety systems	54
High-integrity pressure protection system	55
Safety shutdown valve control system	56
DryAccess* deepwater production system	
Production trees	57
Mudline trees	58

Safety Systems

Cameron safety systems are customized to accommodate operators' specific requirements to achieve ultimate valve control and absolute well safety.

Wellhead control panels and surface safety systems

Cameron offers systems for control of surface, topside, and subsea trees. These wellhead control panels and surface safety systems feature quality design and include premier components. Cameron safety control systems are designed to shut in a flowline in the event of abnormal conditions, malfunction, or irregularity.

PLC and SCADA controls systems

We provide process monitoring and control, from simple logic and telemetry to fully integrated systems. These systems feature quality design, layout, programming, and commissioning with a focus on programmable logic control (PLC)–based controls and logic systems.

Chemical injection and injection rate control device systems

Cameron systems for chemical agent management assure flow and improve production with field-proven, simple, and reliable performance. Our systems range from small, single-well surface systems to large, multiwell subsea applications.

Electrical pump hydraulic control system

The Cameron electric self-contained pump control (ESPC) system is used to operate a hydraulically actuated surface safety valve using electrical power. The ESPC mounts directly onto the hydraulic actuator to be operated. The unit is used in conjunction with an electrical control panel that controls the operation and shutdown logic of the system.

Cameron safety systems deliver sequenced control for multiple well configurations and types.



High-Integrity Pressure Protection System (HIPPS)

When operating in high-pressure environments and production fields, an overpressure event can cause damage to the environment, infrastructure, and personnel. Mitigating that risk on production wells and flowlines is a challenge that can be met with a HIPPS, a safety-instrumented system designed to prevent overpressurization in piping systems and processing facilities.

The Cameron HIPPS is an independently instrumented system designed with higher integrity compared with process shutdown (PSD) and ESD systems. Suitable for onshore and offshore installations requiring high-integrity pressure protection of downstream systems, the Cameron HIPPS is SIL 3 certified and incorporates our field-proven valves and actuators.

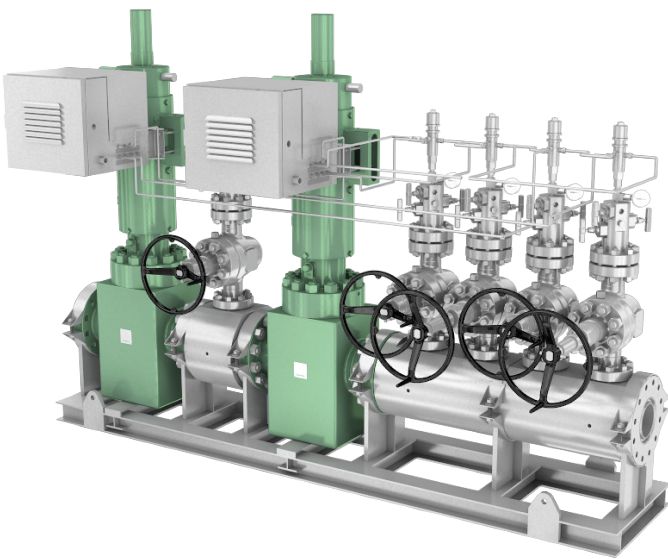

Applications

- Wellhead flowline
- Pipeline and compressor stations
- Flaring systems
- Separation and processing facilities
- Gas plants
- Gas storage
- FPSO vessels
- Offshore platforms
- Onshore operations

Benefits

- Protects downstream equipment
- Minimizes flare system requirements
- Reduces weight of downstream systems
- Maximizes system availability
- Reduces high-pressure pipelines or vessel overpressure risk
- Improves economic viability of a development
- Decreases risk to a facility, plant, or flowline
- Reduces the total load of relief in a relief or flare system

Features

- High-integrity, flexible mechanical and electronic design
- Pneumatic and hydraulic actuator options (conventional or compact)
- Self-contained hydraulic system
- Partial- or full-stroke testing (automated or mechanical)
- SIL 3–certified design
- System diagnostics and status feedback
- Conformance to safety regulations and environmental policies

Safety Shutdown Valve Control System

Safeguarding wells and flowlines is a constant concern for operators no matter what the environment. The operator must have total control of the well at all times, being able to close the fail position of the valve upon hydraulic pressure loss or to perform an ESD.

Designed with field service and minimal downtime in mind, the Cameron safety shutdown valve control system can be adapted to work with other components in various configurations. When an abnormal condition occurs, the safety shutdown valve and controls must be manually reset to be put back into service. A protective enclosure protects the system against the elements.

Using a hand pump with various control components, a zero-leakage circuit is maintained to ensure valve movement does not inadvertently occur until a fail-safe signal is received. Controls are typically pilot tripped, but solenoids also can be utilized for remote control where electricity is available. The control must be manually reset after a fail-safe operation has occurred.

Applications

- Hydraulic fracturing
- Separation and processing facilities
- Gas plants
- Gas storage
- FPSO vessels
- Offshore platforms
- Onshore operations

Advantages

- Rugged stainless steel fabrication to withstand harsh working environments and to provide a corrosion-free environment for the fluid
- Bright red-colored handle on manual arming valve for highly visible local verification of system status being armed or tripped
- Hand pump available in 5,000-psi [345-bar] gauge pressure output to minimize actuator sizing and to reduce necessary fluid capacities
- Seal material that exceeds ambient conditions of the end destination to assure zero-leakage integrity throughout a range of -50 to 212 degF [-46 to 100 degC]
- Liquid level gauge for easy confirmation of proper hydraulic fluid operating level
- Dual filtration within hydraulic circuit ensures only contaminant-free hydraulic fluid is moving within the system to extend zero-leak performance
- Reduced pressure control system that provides access to a broad range of low-pressure, zero-leakage control options (e.g., pilot valves, low-wattage solenoids, fusible plugs)

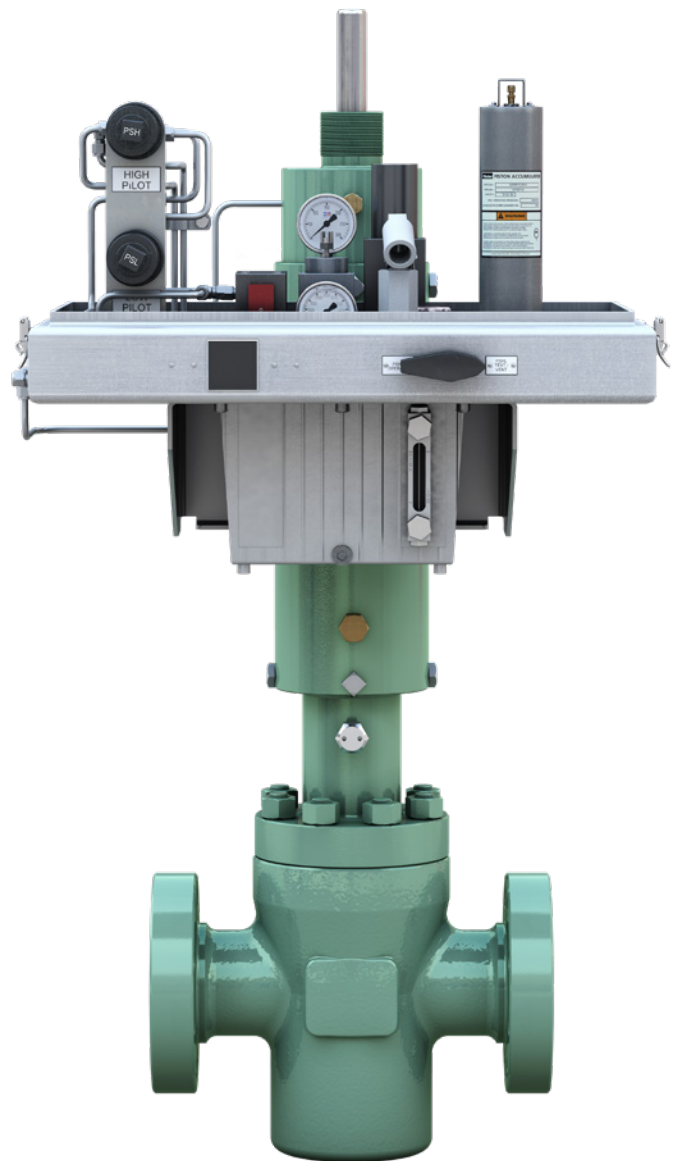

The self-contained control unit is shown on a linear actuator, which helps to operate a 3/8-in API 6A gate valve. The control is displayed as if the optional pilot valve (not illustrated) were installed on the pipeline. Custom tubing connections made between the control and pilot valve are required.

DryAccess Deepwater Production System

In tension-leg platform (TLP) and spar top-tensioned riser (TTR) applications, establishing reliable access to subsea wells from surface can be a time-consuming challenge. In the early execution phase of a project, thousands of hours in third-party engineering and interface management can be required to ensure safe, reliable, and efficient access during the well construction, operating, and production phases of the project.

DryAccess* deepwater production systems provide complete, seamless integration of three critical vertical access interface systems from one supplier, resulting in substantial cost savings for the operator. This solution optimizes the execution phase for TTR systems, including the engineering, interface management, and system integration testing (SIT), which are critical-path activities in the overall project schedule and can significantly affect ultimate production.

DryAccess systems comprise

- fatigue-resistant WellAnchor* advanced subsea wellhead system, which features unique parallel-bore metal-to-metal sealing technology and the ability to install and test hangers and seal assemblies in open water
- high-capacity versatile tieback connectors that provide a reliable connection between the subsea wellhead and riser system
- compact and high-availability surface wellheads and trees.

Applications

- Subsea well access

Advantages

- Early, effective collaboration from concept through project execution
- Ideally configured field development solutions
- Reduced capex, opex, and cycle time through reduced risk of delays
- Minimized need for equipment redesign and interface management
- Maximized production through the life of the field

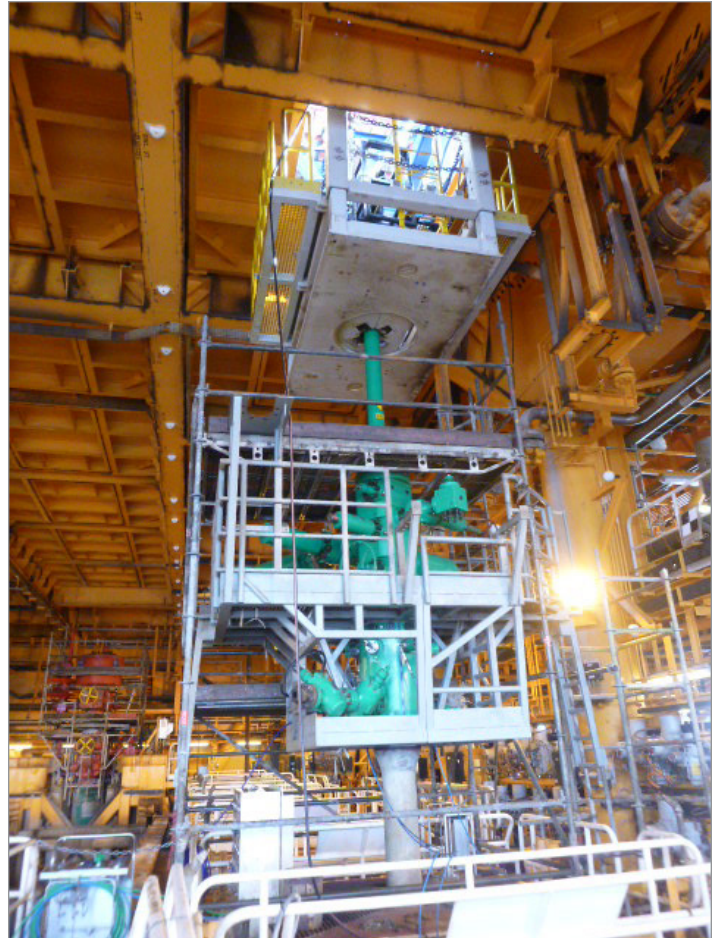

Highly versatile Cameron surface wellhead and tree systems streamline handling during installation and operations, helping to improve efficiency in complex subsea applications.

Production Trees

Cameron surface wellhead and tree systems for spar and tension-leg platform (TLP) applications provide proven functionality and reliability in a compact envelope at the topsides. The sealing technology used in the compact surface wellhead and tree components translates to lower riser payload, reduced footprint, easier access to trees, and higher uptime.

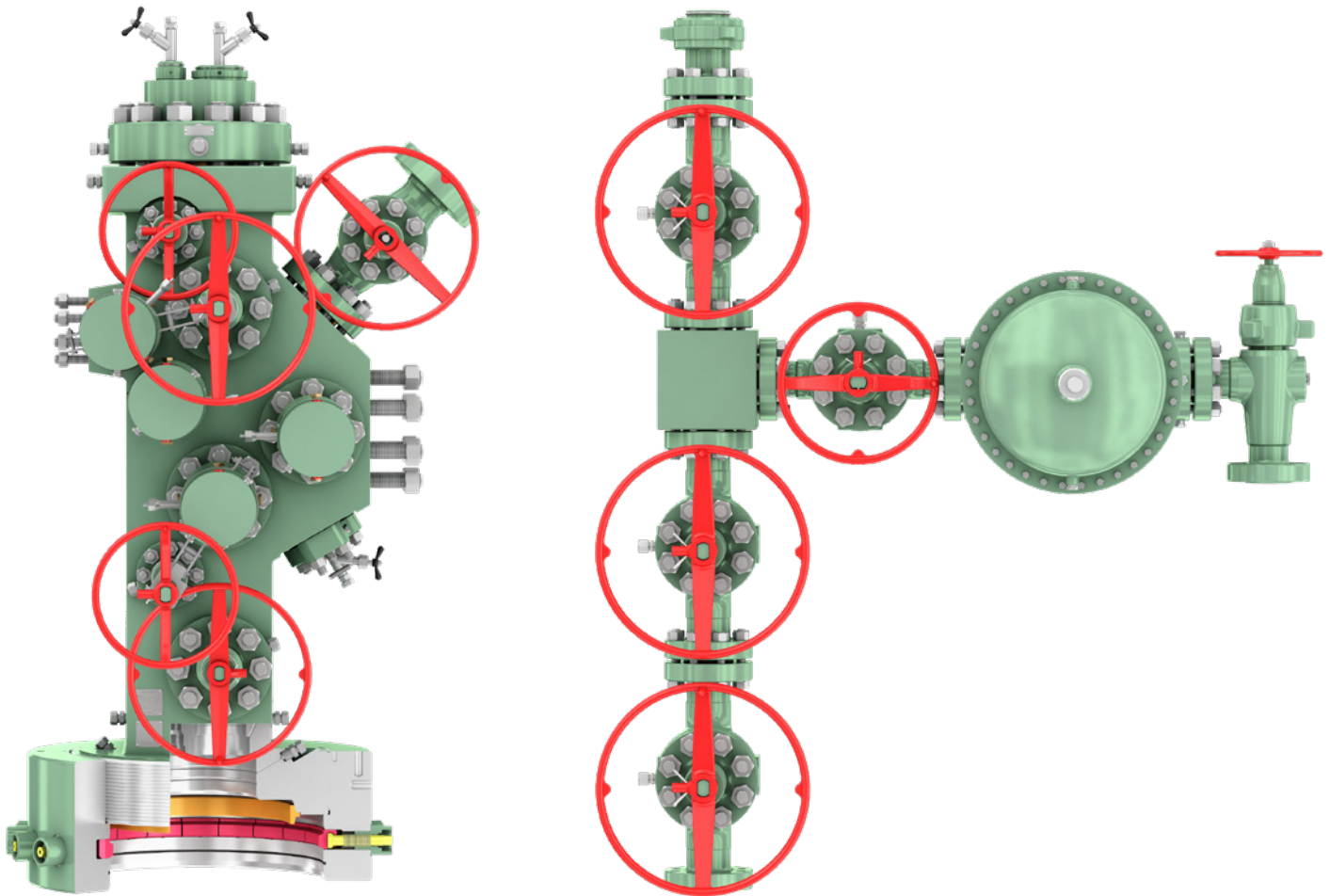

Leveraging our wellhead expertise, we offer compact wellhead and tree design options that conform to surface systems requirements.

Mudline Trees

The MX subsea tree is a simple production system that can be economically installed on a mudline well from a jackup rig. This system uses diver assistance to minimize cost and complexities and is well suited for shallow-water production projects.

- Ability to be installed over Cameron and third-party mudline products
- Minimized cost and low maintenance
- Availability for single- or multiple-string completions
- Reliable and field-proven fail-safe gate valves available in either a stacked or composite valve block configuration
- Option of completing inside 9 $\frac{5}{8}$ -in or 7-in casing
- Primary metal-to-metal seals used at all environmental interfaces
- Self-orienting tubing hanger with positive lockdown and antirotation capabilities

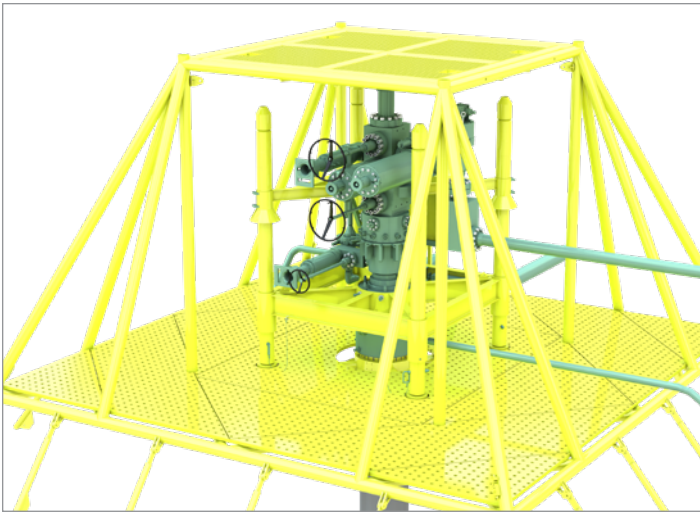

MX mudline trees can be installed from a jackup rig.

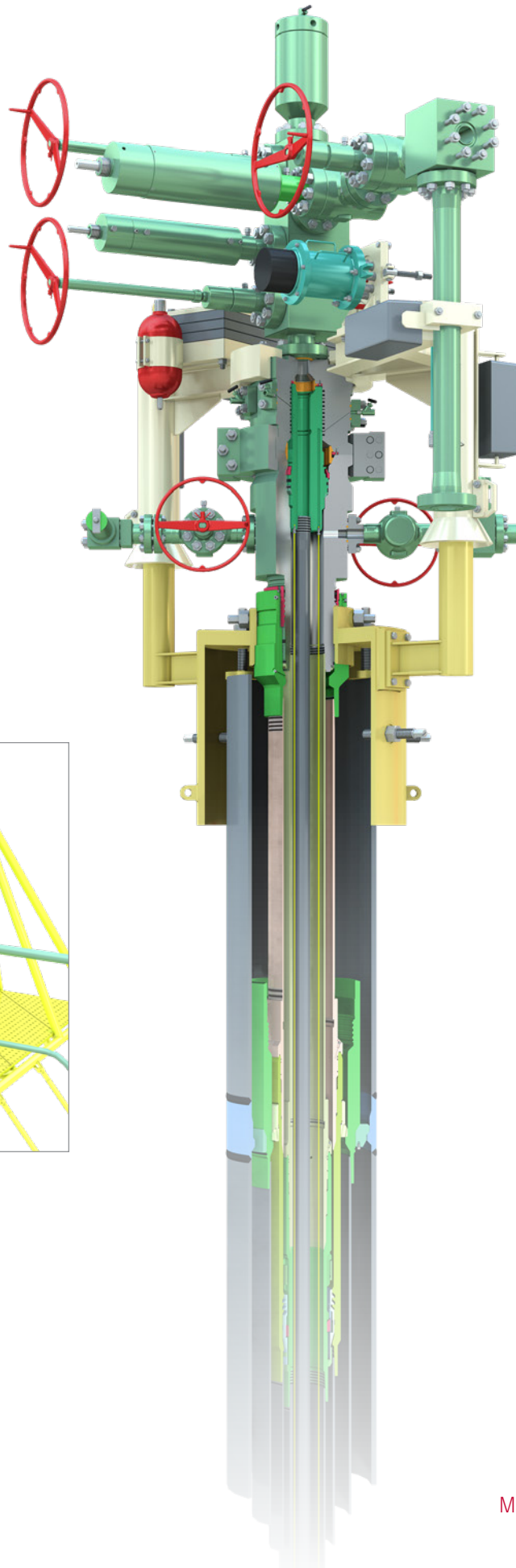



The height and weight achievable with our compact wellhead and tree designs offer ease of handling during installation and operations.



Geothermal

Cameron geothermal wellhead systems provide fluid control for virtually any type of geothermal reservoir.

Geothermal wellhead systems	60
Geothermal valves	61

Geothermal Wellhead Systems

Cameron geothermal wellhead systems provide fluid control for vapor dominated, liquid dominated, dry hot rock, and geopressured rock. In addition, our wellhead systems can be used on thermally enhanced (steam injection) recovery, waste disposal, and hot-water wells.

FOSTER conventional geothermal wellhead system

The FOSTER system has earned a worldwide reputation for reliable service. It incorporates years of proven design, static sealing elements, and an array of design configurations that are cost effective and enhance safety.

Compact geothermal wellhead system

The Cameron compact geothermal wellhead system is a horizontal production system based on the highly successful geothermal compact tree (GCT) system, which has long been regarded as the benchmark of the industry. The compact design of this wellhead can help reduce drilling, production, and construction costs. The shallow cellar requirement reduces pipeline costs, decreases personnel requirements, and provides a safer working environment.

The Cameron compact geothermal wellhead system is available in all popular sizes and working pressures in either solid block or conventional flanged designs.



Geothermal Valves

WKM Pow-R-Seal double expanding gate valve

WKM Pow-R-Seal* double expanding gate valves have been successfully employed for many years in geothermal service; in flowlines; and as main, wing, and casing head valves on wellheads. Pow-R-Seal valves are available with flanged and weld ends, in 2-in through 36-in bore sizes, and in ANSI classes 150, 300, 400, 600, 900, and 1500. These valves meet API 6D requirements and are ideal for storage, manifold, processing, steam, and hot-water applications. API 6A-rated 2-in and 3-in sizes, with 2,000-, 3,000-, and 5,000-psi working pressure, are used on steam wells as casing head valves.



WKM Pow-R-Seal double expanding gate valve.

Foster 4000-F gate valve

Manufactured to API 60 and ANSI B16.34 standards, Foster 4000-F* API 6A geothermal slab-style gate valves have been highly successful in geothermal service. The slab-gate and single-seat design assures reliability and long service life. These valves are available with flanged and weld ends in ANSI classes 150 through 1500 and in bore sizes 2 in through 24 in.

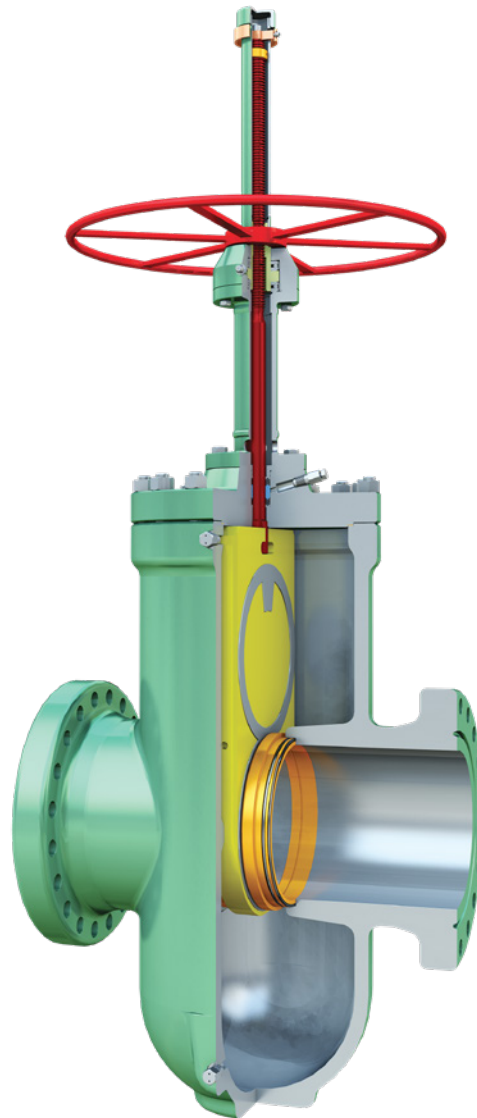

Foster 4000-F API 6D geothermal slab-style gate valve.

Geothermal wellhead systems are customized to individual field requirements and operator objectives.





Heavy Oil

There are several proven methods of recovering heavy oil, such as cold heavy-oil production with sand (CHOPS), cyclic steam stimulation (CSS), and steam-assisted gravity drainage (SAGD). Cameron heavy-oil wellhead systems provide fluid and pressure control for effective heavy-oil recovery.

FC fast-connect HT wellhead system	64
QC quick-connect wellhead system	65

FC Fast-Connect HT Wellhead System

The compact FC* fast-connect HT wellhead system is designed for high-temperature applications, such as thermal recovery of heavy oil. It offers an alternative to conventional wellhead systems and can also be used for cold production methods. It reduces HSE risk because most of its components are installed through the BOP stack, optimizing installation time and minimizing rig time.

Applications

- Thermal production
- Cold production
- Cyclic steam stimulation (CSS)

Advantages

- Casing head and tubing spool that feature other end connectors, which meet API 6A standards
- Threading on all connections, meaning the need to cut, bevel, or make pipe welding is eliminated for typical installation
- Segmented landing base with holes, enabling the observation of returns or performing top job cementing
- Ideal design for drilling wells in phases or stages in clusters or pads, using an internally threaded plug to ensure well control while the drilling rig moves off location
- Ability to expand casing (2 ft) in thermal applications without restricting flow while accommodating wellhead axial and radial stress conditions
- Threaded flange for quick and easy alignment of the wellhead system with steam, flowlines, or both
- Rating of 0 to 650 degF at a maximum pressure of 3,000 psi
- Accommodation of 13 $\frac{3}{8}$ -in \times 9 $\frac{5}{8}$ -in \times 5 $\frac{1}{2}$ -in casing program
- Elimination of time spent waiting on cement

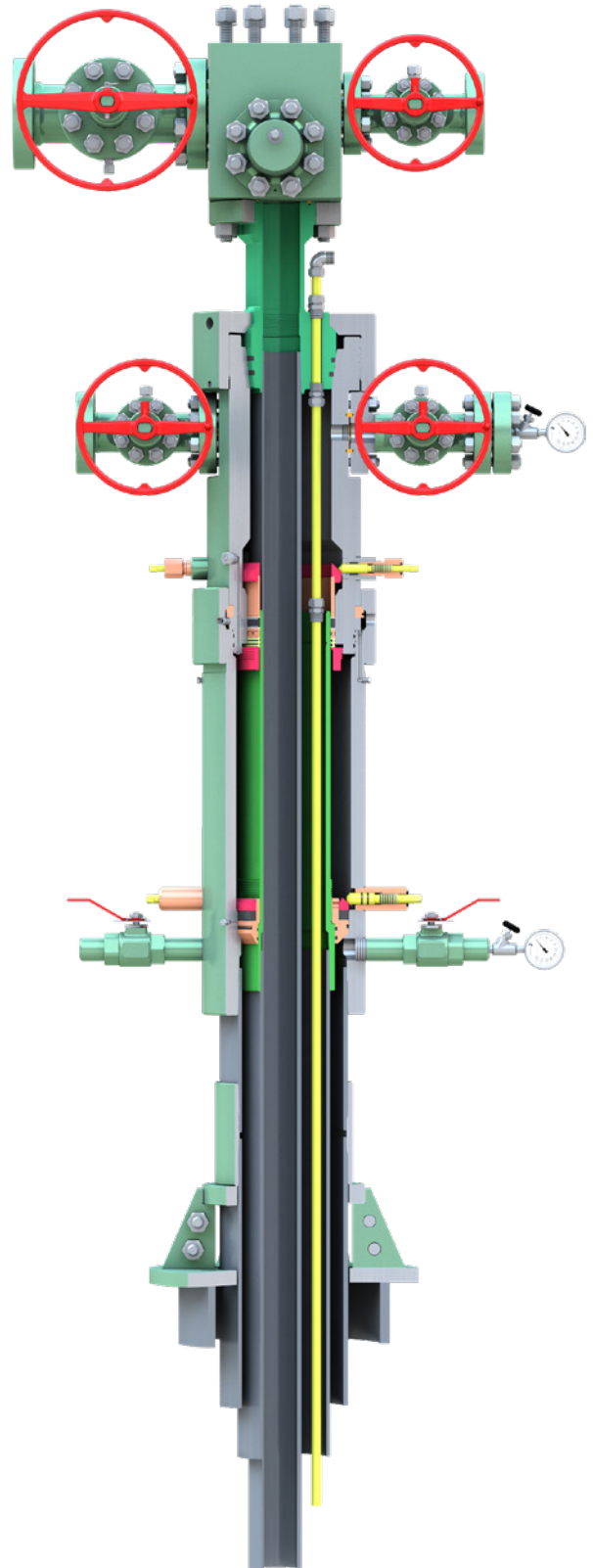

QC Quick-Connect Wellhead System

The QC* quick-connect wellhead system is designed for cold heavy-oil production with sand (CHOPS), a technique that enables continuous production of sand with oil and leads to improved recovery of heavy oil from the reservoir. In many cases, wormholes are formed in the unconsolidated sand reservoir, increasing well productivity. The compact QC wellhead system provides operational flexibility and ease of use; it can also be used with other cold recovery methods. Because it uses elastomers, conventional running techniques are applicable.

Applications

- Heavy oil
- EOR
- Cold production

Benefits

- Enables running, locking down, overpulling, and pressure testing the seal prior to releasing the running tool
- Enhances operational certainty by securely sealing and testing the annulus prior to rigging down the BOP stack

Features

- Operational flexibility and ease of use
- Incorporation of SpoolTree* horizontal subsea tree system
- No need to remove production wing valves or flowline for well intervention or progressing cavity pump (PCP) repair
- Casing head and tubing spool that feature dual seals for rapid completion and testing

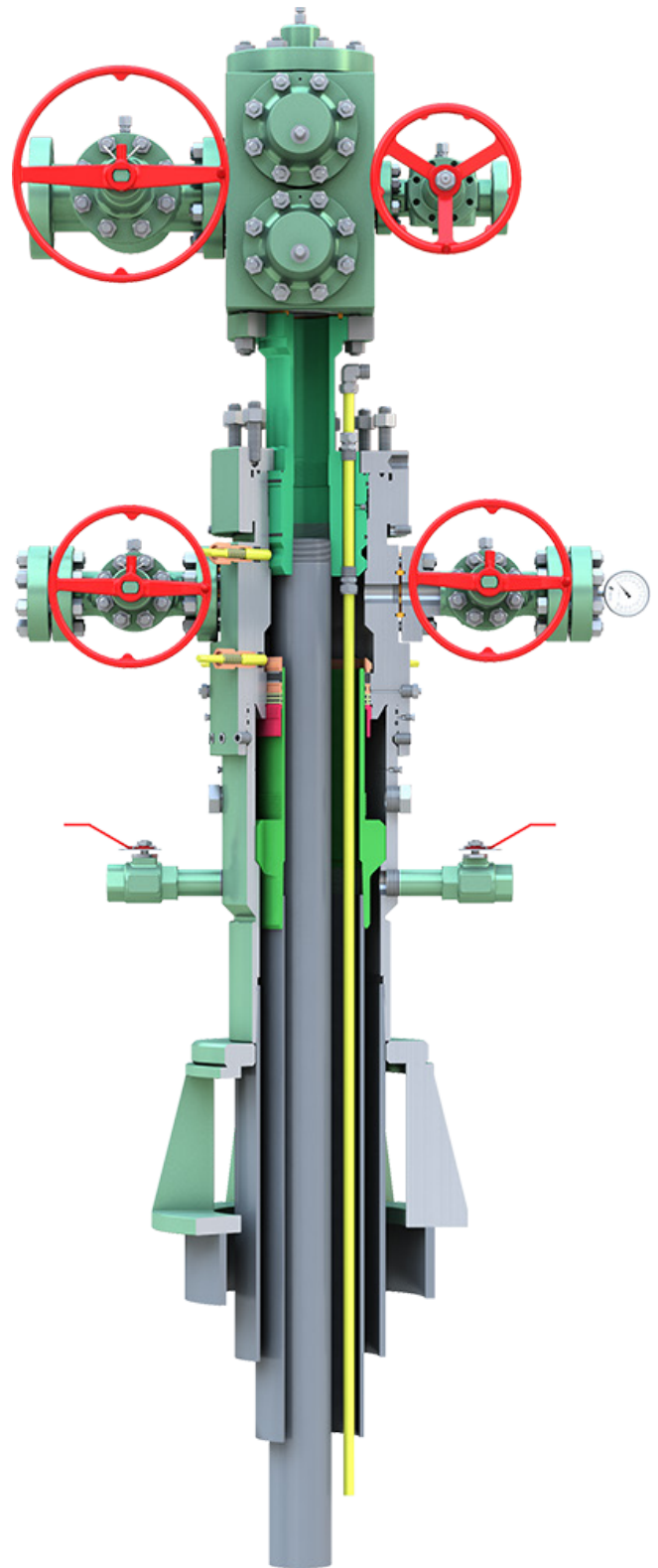



Cameron heavy-oil wellhead systems provide fluid and pressure control for effective recovery.



Surface Chokes

Choke valves provide pressure and flow control across a wide range of applications, such as wellheads, production manifolds, and choke and kill manifolds. We supply various types of proven, durable choke valves for standard, erosive, and corrosive service. A dedicated choke maintenance program and choke erosion monitoring services enhance reliability.

Control chokes	68	Drilling chokes	73
Multitrim chokes	69	Willis MOV (disc-style) chokes	73
H2 needle-and-seat chokes	70	CAM30-DC drilling choke	73
AOP valve and choke technologies	71	DR20 2-in and DR30 3-in gate-and-seat drilling chokes	73
Multistage chokes	72		

Control Chokes

Cameron control chokes incorporate hydrodynamic energy dissipation to reduce erosion problems while ensuring positive flow control. During service, the flow enters the choke inlet and circulates around the annulus between the body and cage. The cage has an even distribution of ports that determine the maximum flow capacity.

The high-velocity fluid streams produced by the flow collide in the center of the cage. Because the fluid streams impinge directly with each other, this enables the most erosive energy to be dissipated. This in turn minimizes the risk of erosion damage to downstream components.

Applications

- Production
- Injection
- Artificial lift
- Flowback
- Storage

Advantages

- Precise flow control under severe service conditions
- Availability with plug-and-cage, external-sleeve, or multistage trims as well as special trim solutions, including ultralow C_v , low noise, and well cleanup
- Multiple flow characteristics
- Complete solution from startup to late life
- Easy retrofit as conditions evolve

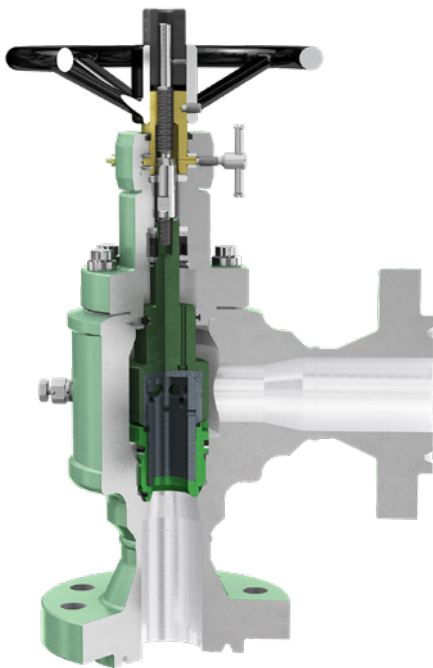

CC40 control choke with plug and cage trim.

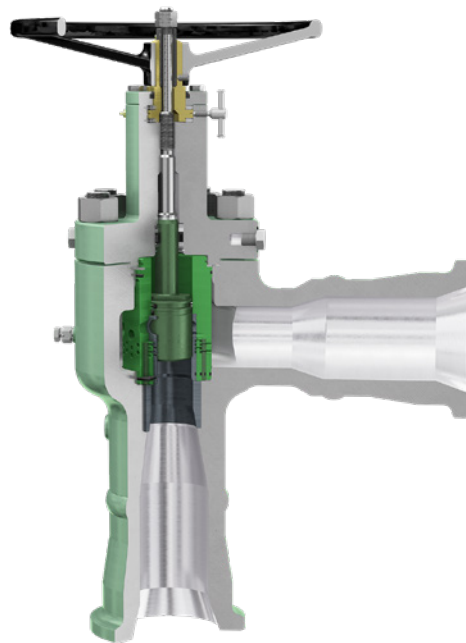

CC30 control choke with external sleeve trim.

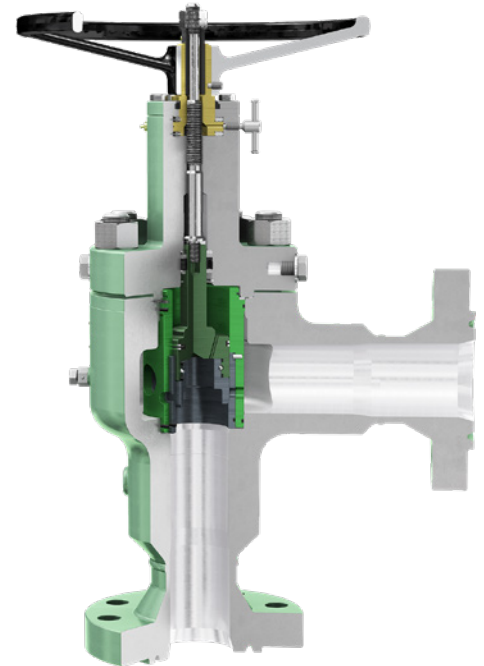

CC40 control choke with multistage trim.

Multitrim Chokes

With multiple trim options to suit changing conditions, Cameron multitrim choke valves are suitable for a wide range of operations. The modular design and easily interchangeable trim styles provide chokes with enhanced versatility. Adapting the choke valve for different modes of actuation does not require choke disassembly, minimizing production downtime.

Chokes are frequently exposed to erosive wear because of sand and other particles in the production fluids. If left unattended, washouts and choke failures can result, endangering personnel and environmental safety as well as causing loss of production. Multitrim choke valves offer full trim interchangeability, enabling planned maintenance for increased uptime.

Changing trims saves the time and cost associated with purchasing a different type of choke when well conditions change. The multitrim choke valves have a significantly extended service life with enhanced controllability due to innovative trim design and the use of advanced materials. The result is more efficient production and less formation damage.

Applications

- Oilfield production
- Flowback
- Injection
- Standard and severe service operations

Advantages

- Modular design that is quickly adapted for manual or actuated operation
- Easily interchangeable manual and actuated configurations and trim styles
 - Needle and seat
 - External sleeve
 - Plug and cage
 - Positive bean and fixed orifice
- No requirement to disassemble choke when adapting from manual to actuated mode, decreasing production downtime
- Enhanced erosion resistance achieved by using the external floating sleeve (FS) trim

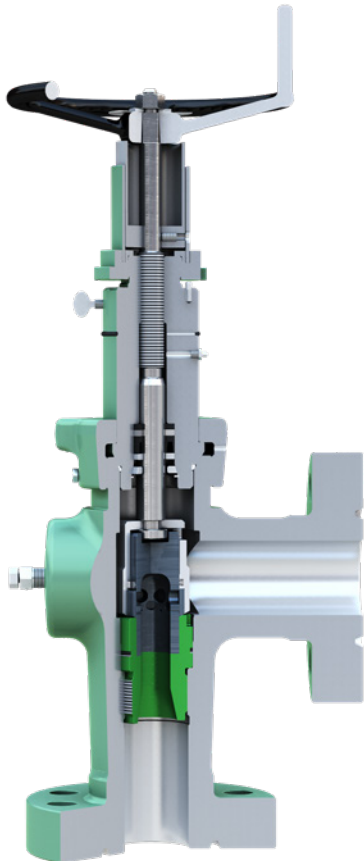

Manual CAM30-MT choke with FS trim.

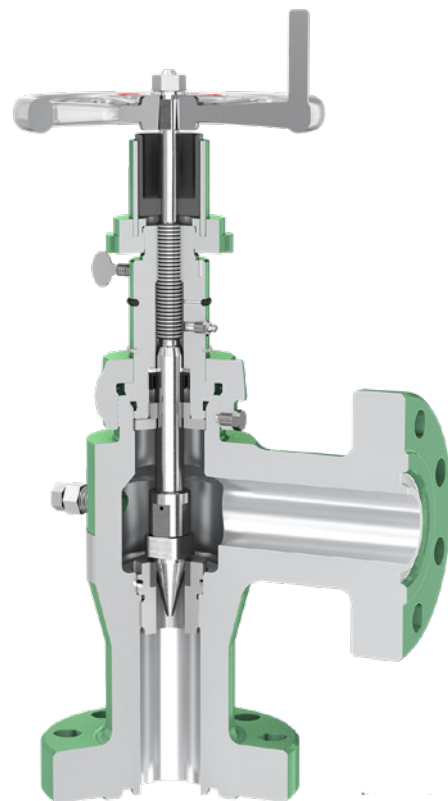

CAM20-MT choke with external sleeve (ES) trim.

H2 Needle-and-Seat Chokes

The family of H2* needle-and-seat chokes is ideally suited for a broad range of choke applications, including wellhead, production manifolds, choke and kill manifolds, well testing, and cleanup operations. The classic H2 choke handles standard, erosive, and corrosive service in stride with pressure ratings up to 15,000 psi.

Two configurations are available:

- positive choke: provides a fixed flow condition with a large selection of available bean sizes and types
- adjustable choke: provides variable flow rates but can be locked into position if a fixed flow rate is required.

Applications

- Wellhead
- Production manifolds
- Choke and kill manifolds
- Well testing
- Cleanup operations

Advantages

- Optional combination bean and seat to enable converting the adjustable choke to a positive adjustable choke for bringing the well on slowly
- Ability to operate as a positive choke valve once desired flow rate is reached to reduce wear on the wing or master gate valves
- Long life and low maintenance

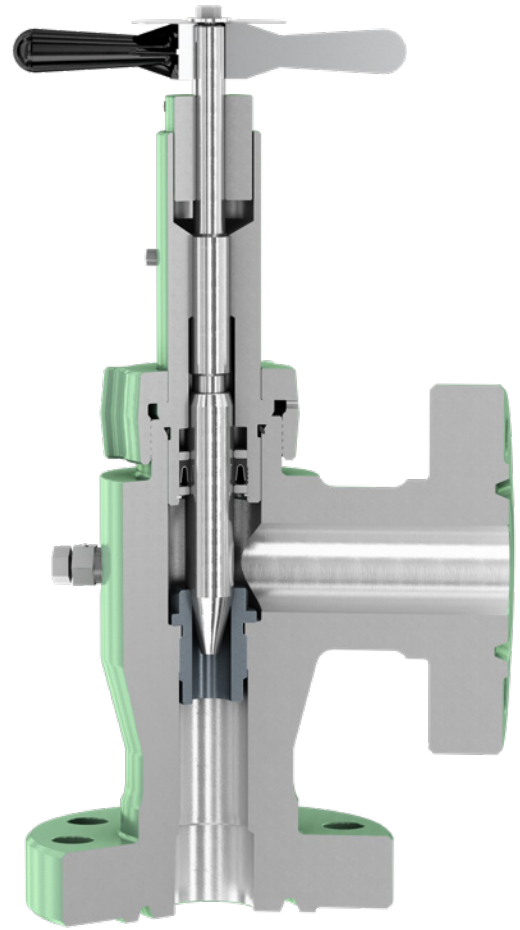

H2 needle-and-seat choke.



The H2 choke utilizes a simple needle-and-seat type trim to control the flow, pressure, or both and is used in a wide variety of applications.

AOP Valve and Choke Technologies

AOP* valve and choke technologies are general-purpose chokes suitable for a host of applications within the oil and gas industry. Based upon the proven needle-and-seat principle and optimized through design, these choke products offer a comprehensive solution for challenging flow control applications throughout the industry.

Our AOP technologies are characterized by their robust, streamlined design features and rugged, easily assembled components. They are available in pressure ratings of up to 10,000 psi and in a combination of threaded, butt-welded, and flanged interface connections. Positive or adjustable trim configurations can be specified.

As part of our commitment to meeting customer needs, AOP technologies are stocked by a network of authorized distributors and are marketed worldwide through our representatives.

Applications

- Oil and gas operations

Advantages

- Adjustable and positive options
- ANSI Class 150 through 600 and ANSI Class 2,000 through 10,000
- High adjustability for easy adaptation to positive configuration
- Forged or cast carbon steel body
- Heat-treated, hardened steel stem and seat with optional stainless steel or tungsten carbide trim
- AOP Series BHF* flanged choke that is interchangeable with H2 needle-and-seat choke
- Thumbscrew that secures stem position at any setting
- Lube fitting that enhances corrosion-resistant, smooth stem operation
- Adjustable models available with 3/4-in or 1-in maximum orifice, both adjustable in 1/64-in increments
- 100% production testing
- Hammer lug models that facilitate quick disassembly
- Pressure-relief-vented lugs for safe removal

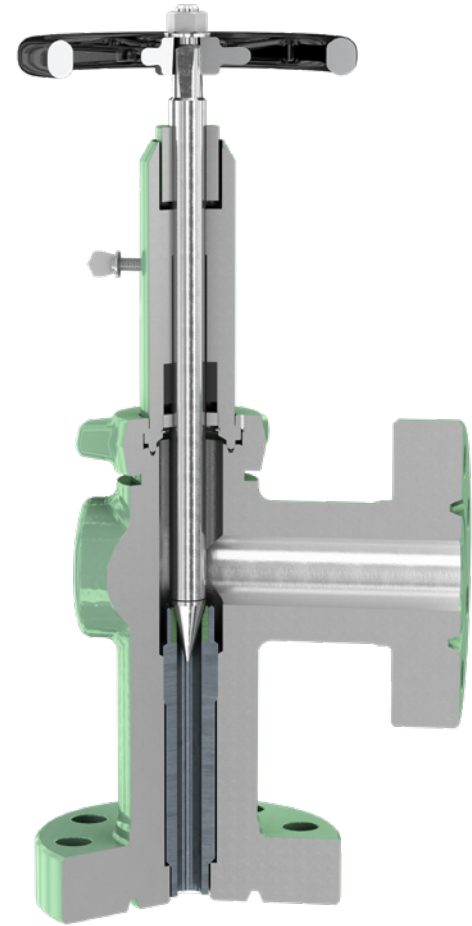

AOP Series BHF threaded flanged choke.*

Multistage Chokes

Multistage choke trim is used in applications in which high differential pressures result in unacceptably high noise and vibration levels, especially in gas service. Multistage trims are also commonly used to prevent cavitation in the case of liquids, particularly for water injection.

The trim works by reducing the pressure over a number of discrete stages, giving a carefully managed pressure profile. Similarly, it manages the velocities within the trim and prevents the occurrence of undesired flow effects such as sonic velocities and high-velocity jetting. A number of multistage trim options are available.

Applications

- Water injection
- High-pressure gas operations

Advantages

- Trim porting and geometry designed to convert potential energy to kinetic energy and heat
- Large trim surface area that increases wall friction
- Directional changes in trim that reduce energy levels
- Interstage chambers that enable fluid expansion to reduce velocities
- Design that forces fluid through repeated compression and expansion phases
- Pressure-balanced stem and thrust bearings for reduced torque
- Large annulus area that decreases the risk of body and trim erosion caused by high velocities

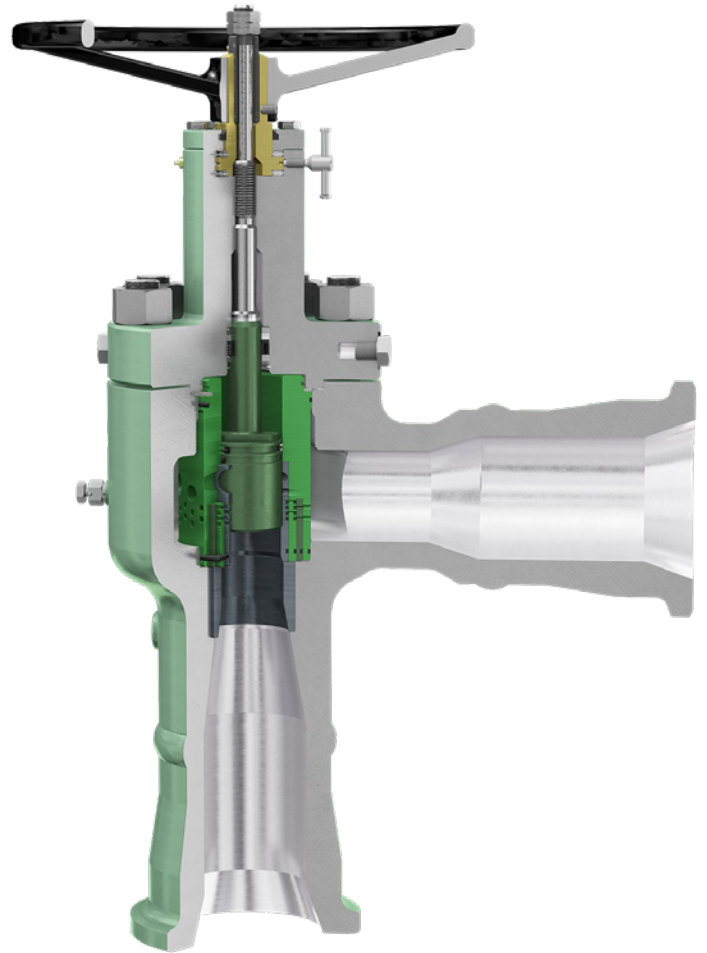

Multistage MS-33 choke.

Drilling Chokes

Drilling choke valves manage wellbore pressure to maintain control in the event of a gas kick, circulate out the kick, and prevent loss of well control. Cameron drilling chokes include

- Willis MOV (disc-style) chokes, which utilizes a set of adjacent discs, each containing a pair of circular openings or orifices
- CAM30-DC drilling choke, which offers the versatility to switch between various trim styles for greater controllability and erosion resistance
- DR20* 2-in and DR30* 3-in gate-and-seat drilling chokes, which enable up to twice the service life of a normal nonreversible drilling choke trim.

Applications

- Choke and kill manifolds
- Conventional drilling
- MPD
- Underbalanced and dual-gradient drilling

Advantages

- Wellbore pressure control during drilling
- Circulation of any kicks of gas encountered during drilling
- Prevention of well control loss by maintaining a satisfactory column of drilling mud
- Several options and configurations
- Proven performance within diverse drilling applications on a global scale

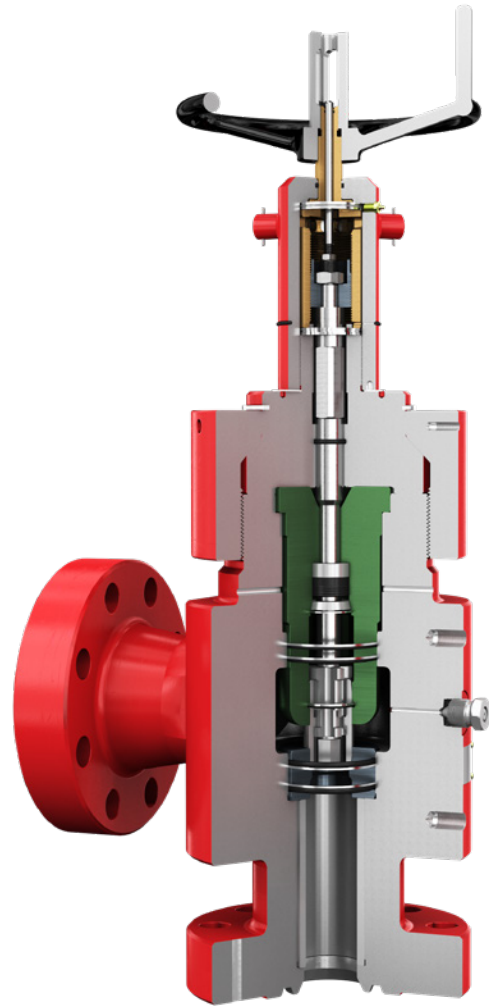

DR20 2-in gate and seat drilling choke.



With several options and configurations, Cameron drilling chokes offer proven performance within a range of dynamic drilling applications.

The CAM20-MT choke is a modular design that easily adapts to multiple trim types and manual or actuated operation.



Surface Systems Technology



slb.com

*Mark of Schlumberger
Other company, product, and service names
are the properties of their respective owners.
Copyright © 2017 Schlumberger. All rights reserved. 17-SUR-271492

 **CAMERON**
A Schlumberger Company