

TASCAM

TEAC Professional Division

MSR-16

1/2" 16-Track Recorder/Reproducer



OPERATION MAINTENANCE

MSR-16-1

The guarantee provided for the MSR-16 has several restrictions. The MSR-16 will perform properly only if it is adjusted properly and we guarantee that such adjustment is possible. Setup is not covered by Warranty. If your attempts at internal adjustments are unsuccessful, we will charge you for readjustments.

Recording is an art as well as a science. As a result, your finished product may be judged more by artistic criteria than technical performance. Art is the province of the artist and TASCAM can make no guarantee that the MSR-16, *by itself*, will assure the quality of your work.

Your skill as a technician and your abilities as an artist will be significant factors in the results you achieve.

Bescheinigung des Herstellers/Importeurs

Hiermit wird bescheinigt, daß der/die/das

MAGNETTONBANDGERÄT TASCAM MSR-16

(Gerat. Typ. Bezeichnung)

in Übereinstimmung mit den Bestimmungen der

AMTSBLATT 163/1984, VFG 1045/1984, VFG 1046/1984

(Amtsblattverfügung)

funk-entstört ist.

Der Deutschen Bundespost wurde das Inverkehrbringen dieses Gerätes angezeigt und die Berechtigung zur Überprüfung der Serie auf Einhaltung der Bestimmungen eingeräumt.

TEAC CORPORATION

Name des Herstellers/Importeurs

THE APPLIANCE CONFORMS WITH EEC DIRECTIVE 87/308/EEC REGARDING INTERFERENCE SUPPRESSION

CONFORME AL D.M. 13 APRILE 1989
DIRETTIVA CEE/87/308

“© Copyright 1988, TEAC Corporation”

All rights reserved under international and Pan American copyright conventions. This book may not be reproduced in whole or in part, by mimeograph or any other means, without permission.



CAUTION: TO REDUCE THE RISK OF ELECTRIC SHOCK, DO NOT REMOVE COVER (OR BACK). NO USER-SERVICEABLE PARTS INSIDE. REFER SERVICING TO QUALIFIED SERVICE PERSONNEL.



The lightning flash with arrowhead symbol, within an equilateral triangle, is intended to alert the user to the presence of uninsulated "dangerous voltage" within the product's enclosure that may be of sufficient magnitude to constitute a risk of electric shock to persons.



The exclamation point within an equilateral triangle is intended to alert the user to the presence of important operating and maintenance (servicing) instructions in the literature accompanying the appliance.

This appliance has a serial number located on the rear panel. Please record the model number and serial number and retain them for your records.
Model number _____
Serial number _____

WARNING: TO PREVENT FIRE OR SHOCK HAZARD, DO NOT EXPOSE THIS APPLIANCE TO RAIN OR MOISTURE.

SAFETY INSTRUCTIONS

CAUTION:

- Read all of these instructions.
- Save these instructions for later use.
- Follow all warnings and instructions marked on the audio equipment.

1. **Read Instructions** — All the safety and operating instructions should be read before the appliance is operated.
 2. **Retain Instructions** — The safety and operating instructions should be retained for future reference.
 3. **Heed Warnings** — All warnings on the appliance and in the operating instructions should be adhered to.
 4. **Follow Instructions** — All operating and use instructions should be followed.
 5. **Water and Moisture** — The appliance should not be used near water — for example, near a bathtub, washbowl, kitchen sink, laundry tub, in a wet basement, or near a swimming pool, etc.
 6. **Carts and Stands** — The appliance should be used only with a cart or stand that is recommended by the manufacturer.
- 6A. An appliance and cart combination should be moved with care. Quick stops, excessive force, and uneven surfaces may cause the appliance and cart combination to overturn.

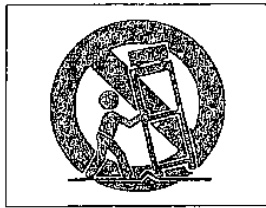

7. **Wall or Ceiling Mounting** — The appliance should be mounted to a wall or ceiling only as recommended by the manufacturer.
8. **Ventilation** — The appliance should be situated so that its location or position does not interfere with its proper ventilation. For example, the appliance should not be situated on a bed, sofa, rug, or similar surface that may block the ventilation openings; or, placed in a built-in installation, such as a bookcase or cabinet that may impede the flow of air through the ventilation openings.
9. **Heat** — The appliance should be situated away from heat sources such as radiators, heat registers, stoves, or other appliances (including amplifiers) that produce heat.
10. **Power Sources** — The appliance should be connected to a power supply only of the type described in the operating instructions or as marked on the appliance.
11. **Grounding or Polarization** — The precautions that should be taken so that the grounding or polarization means of an appliance is not defeated.
12. **Power-Cord Protection** — Power-supply cords should be routed so that they are not likely to be walked on or pinched by items placed upon or against them, paying particular attention to cords at plugs, convenience receptacles, and the point where they exit from the appliance.

13. **Cleaning** — The appliance should be cleaned only as recommended by the manufacturer.
14. **Power Lines** — An outdoor antenna should be located away from power lines.
15. **Outdoor Antenna Grounding** — If an outside antenna is connected to the receiver, be sure the antenna system is grounded so as to provide some protection against voltage surges and built up static charges. Section 810 of the National Electrical Code, ANSI/NFPA No. 70 — 1984, provides information with respect to proper grounding of the mast and supporting structure, grounding of the lead-in wire to an antenna discharge unit, size of grounding conductors, location of antenna-discharge unit, connection to grounding electrodes, and requirements for the grounding electrode. See Figure below.

EXAMPLE OF ANTENNA GROUNDING AS PER NATIONAL ELECTRICAL CODE

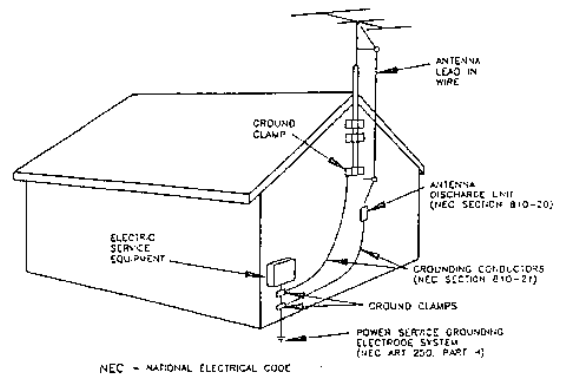

16. **Nonuse Periods** — The power cord of the appliance should be unplugged from the outlet when left unused for a long period of time.
17. **Object and Liquid Entry** — Care should be taken so that objects do not fall and liquids are not spilled into the enclosure through openings.
18. **Damage Requiring Service** — The appliance should be serviced by qualified service personnel when:
 - A. The power-supply cord or the plug has been damaged; or
 - B. Objects have fallen, or liquid has been spilled into the appliance; or
 - C. The appliance has been exposed to rain; or
 - D. The appliance does not appear to operate normally or exhibits a marked change in performance; or
 - E. The appliance has been dropped, or the enclosure damaged.
19. **Servicing** — The user should not attempt to service the appliance beyond that described in the operating instructions. All other servicing should be referred to qualified service personnel.

Introduction

The MSR-16 is an exceptionally reliable and versatile high-performance 16-track, 16-channel tape recorder/reproducer that uses 1/2-inch wide tape on 10-1/2-inch reels and operates at tape speeds of 15 ips (38 cm/s) and 7-1/2 ips (19 cm/s).

The MSR-16 features 8-bit microcomputer control for error-free tape operation. Each channel has its own 4-bit microcomputer to control record in/out circuitry, allowing gapless punch in and out. The transport is the "full servo" type: the capstan motor (brushless) is Phase Locked Loop servoed, and each DC reel motor is under control of the 8-bit microcomputer. The tension arms have non-contacting detectors that constantly send the microcomputer information on tape tension; the microcomputer then adjusts the torque of each reel motor. The result is smooth operation, gentle tape handling, and the capability in edit mode of moving both reels manually with one hand. The capstan motor is a Phase Locked Loop servo using a 9.6 kHz industry standard reference for precise tape speed, and control by all major brands of synchronizers. Major rotating components, including the tension arm guides and the pinch roller, are supported by ball-bearings to provide minimum friction while retaining close tolerance. In fact, the tension arm itself is ball-bearing supported for more sensitive response and greater motor and servo durability. Motion sensing logic ensures fast and smooth transition from one transport mode to another.

The MSR-16 has three different external control interfaces. It has a parallel input port, for connection to SMPTE/EBU based synchronizers (such as the TASCAM ES-50/51); and RS-232C serial synchronizers with serial control (such as the TASCAM MIDIIZER); and a remote control port for the RC-416 remote control unit. The MSR-16 automatically senses when it is under external synchronizer control, switching the servo system between the external source or its

internal reference. Track 16 is fitted with a Sync Lock feature that assures high-quality time code or FSK signals (such as those generated by the TASCAM MTS-30 MIDI Tape Synchronizer) can be recorded and played back without interruption and without dbx processing.

The digital fluorescent tape counter is tach driven, displaying in minutes and seconds the distance the tape has moved from a zero reference point. The counter alternately displays speed variation in percentages of normal speed. A maximum of +/- 15% speed variation is provided by the pitch control both in Record and Playback.

The Rehearsal and Auto In-Out features allow automated control of punch-in and out times without external computer control. When used as the first stage of the Automated punch-in/out operation, the Rehearsal feature programs the MSR-16 to repeat a punch-in/out sequence as many times as you wish before actually executing it on tape. The distance between the erase and record heads is automatically compensated for for gapless "inserts".

In addition to a conventional return-to-zero function, the MSR-16 is equipped with a two-point auto locator, which also provides a repeat playback over the desired segment of the tape.

Other features include LOAD, which prevents tape from running off either end of the reel; a SPOOL mode for uniform tape pack; various EDIT and spot erase features; AUTO INPUT which facilitates communication between studio and control room through the tape returns, and more.

This manual has been designed to help you as you learn how to use those features. Please read it thoroughly and keep it handy as you learn the machine. Taking the time to use this manual now will save you time later on.

TABLE OF CONTENTS

Introduction	4	7. Bouncing Tracks (Ping-pong)	21
Control Signal Block Diagram	5	8. Mixdown (Remix)	23
Specifications	6	9. Recording with Tape Sync	23
Audio Signal Block Diagram	8	Features and Controls	25
Level Diagram	8	How the dbx Works	30
Installations	9	Care and Maintenance	31
Operation		Optional Equipment	32
1. Setting the Record Level	16		
2. Setting the Monitor Level	16		
3. Recording the First Track	16		
4. Overdubbing	17		
5. Punch-in or Insert Recording	18		
6. Rehearsal Programming and Auto-in/out Procedures	19		

(As for the contents of the Maintenance section, which provides service instructions for use by qualified personnel, see the first page of that section.)

Specifications

MECHANICAL

Tape:	1/2 inch (12.7 mm), 50 mil, low noise/high output tape
Track Format:	16-track, 16-channel
Head Configuration:	1 erase, 1 record/reproduce
Motor:	
Capstan:	Phase locked loop DC direct drive motor x1
Reel:	DC motor x2
Reel:	10.5-inch, NAB hub
Tape Speed/Accuracy ³⁾ :	15 ips (38 cm/s) and 7.5 ips (19 cm/s), $\pm 0.2\%$
Pitch Control Range:	$\pm 15\%$ (both in Record and Reproduce)
Wow and Flutter	
15 ips:	$\pm 0.06\%$ peak (DIN weighted)
7.5 ips:	$\pm 0.08\%$ peak (DIN weighted)
Start Time:	0.5 sec. or less (time in which tape motion stabilizes at selected speeds)
Fast Wind Time:	120 sec. or less (10.5-inch reel, 2400-ft tape)
Spooling Time:	400 sec. or less (10.5-inch reel, 2400-ft tape)
Cueing:	Auto (Using the EDIT button)
Motion Sensing:	0.5 sec. ± 0.15 sec. (delay time from stop to next motion)

ELECTRICAL

Line Input (Unbalanced)	
Input Impedance:	50 kOhms
Maximum Source Impedance:	10 kOhms
Nominal Input Level:	-10 dBV (0.316 V)
Maximum Input Level:	+18 dBV (8.0 V)
Line Output (Unbalanced)	
Output Impedance:	220 Ohms
Minimum Load Impedance:	10 kOhms
Nominal Load Impedance:	50 kOhms
Nominal Output Level:	-10 dBV (0.316V)
Maximum Output Level:	+18 dBV (8.0V)
Bias/Erase Frequency:	145 kHz
Equalization:	
15 ips:	$\infty +35 \mu\text{sec.}$ (IEC/CCIR)
7.5 ips:	$\infty +70 \mu\text{sec.}$ (IEC/CCIR)
Record Level:	250 nWb/m (0 VU)
Power Requirements	
USA/CANADA:	120V AC, 60 Hz
U.K./AUSTRALIA:	240V AC, 50 Hz
EUROPE:	220V AC, 50 Hz
GENERAL EXPORT:	100/120/220/240V AC, 50/60 Hz
Power Consumption:	160 W

PERFORMANCE

Frequency Response ²⁾	
15 ips:	40 Hz to 20 kHz $\pm 3\text{dB}$ (at 0 VU)
7.5 ips:	30 Hz to 16 kHz $\pm 3\text{dB}$ (at -10VU)
Repro Frequency Response ¹⁾	
15 ips:	40 Hz to 20 kHz $\pm 3\text{dB}$
7.5 ips:	30 Hz to 16 kHz $\pm 3\text{dB}$
Total Harmonic Distortion (THD) ²⁾ :	0.8% or less at 1,000Hz, 0 VU (250 nWb/m both at 15 and 7.5 ips) (by the reproduce method)
Signal-To-Noise Ratio (ref. to 3% THD)	
15 ips:	108 dB ("A" weighted, with DBX) *
	65 dB ("A" weighted, without DBX)
7.5 ips:	105 dB ("A" weighted, with DBX)
	60 dB ("A" weighted, without DBX)
Crosstalk (between Adjacent Channels):	80 dB or better (1,000 Hz, 0 VU, with DBX)
Erasure:	70 dB or better (1,000 Hz, +10 VU)
Headroom (Record Amp):	28 dB or more (1,000 Hz, 0 VU)

OTHERS

Connector/Jack

Line Input/Output: RCA jack
 Remote Control: D-sub, 25-pin
 Accessory 1 (Parallel): D-sub, 37-pin
 Accessory 2 (Serial): D-sub, 15-pin
 Punch-in/out Remote Control: 1/4" phone jack (for RC-30P)

Standard Equipment:

Power Cord, Empty Reel (RE-1013),
 Operation/Maintenance Manual,
 Warranty Card

Option:

RC-416 Remote Control Unit
 RC-30P Punch-in Footswitch
 RE-1013 Metal Reel (10.5-inch, half-inch)
 CS-607B 19" Console Rack
 LA-40 Low-Impedance Adaptor

Measurements were made using the following TEAC test tapes:

- 1) TEAC YTT-11442 (15 ips, 38 cm/s)/YTT-1143 (7.5 ips, 19 cm/s)
- 2) TEAC YTT-8163 Blank Tape
- 3) TEAC YTT-2104 (15 ips, 38 cm/s)/YTT-2103 (7.5 ips, 19 cm/s)

In these specifications, 0 dBV is referenced to 1.0 Volt. Actual voltage levels are also given in parenthesis. To calculate the 0 dB = 0.775 Volt reference level (i.e., 0 dBm in a 600-Ohm circuit), add 2.2 dB to the listed dB value; i.e. -10 dBV re: 1 V = -7.7 re: 0.775 V.

Changes in specifications and features may be made without notice and obligation.

*dbx is a registered trademark of dbx Incorporated.

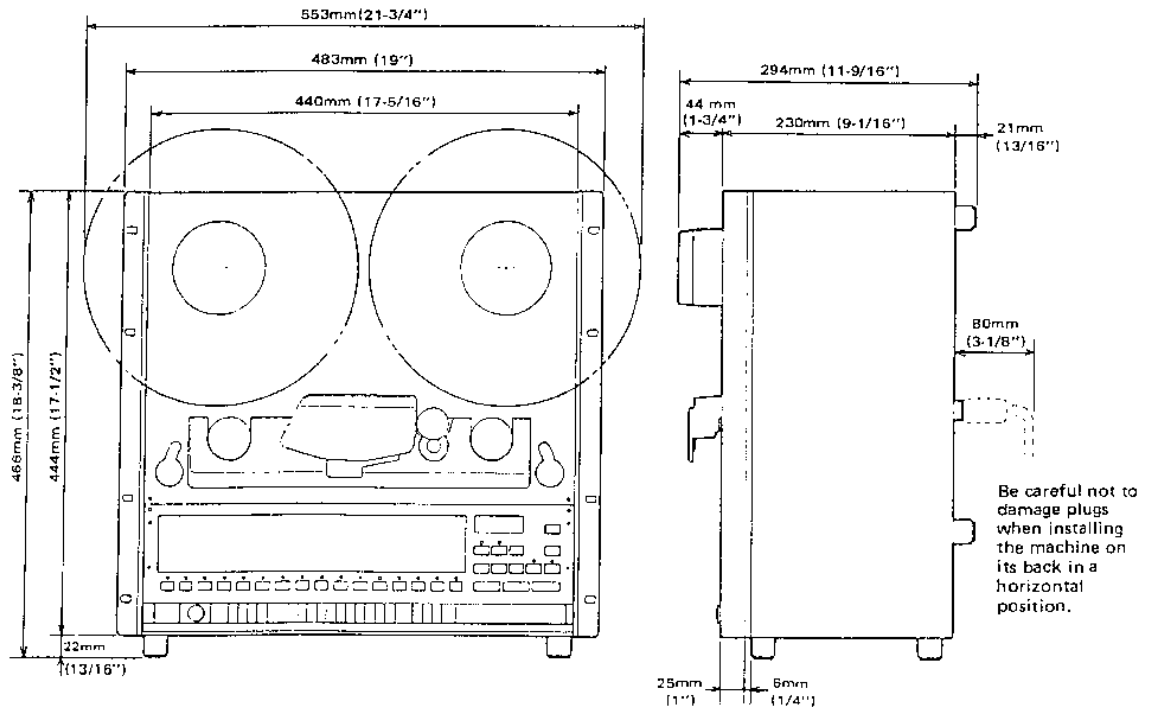

As No. 1 and 2 Disk Drive

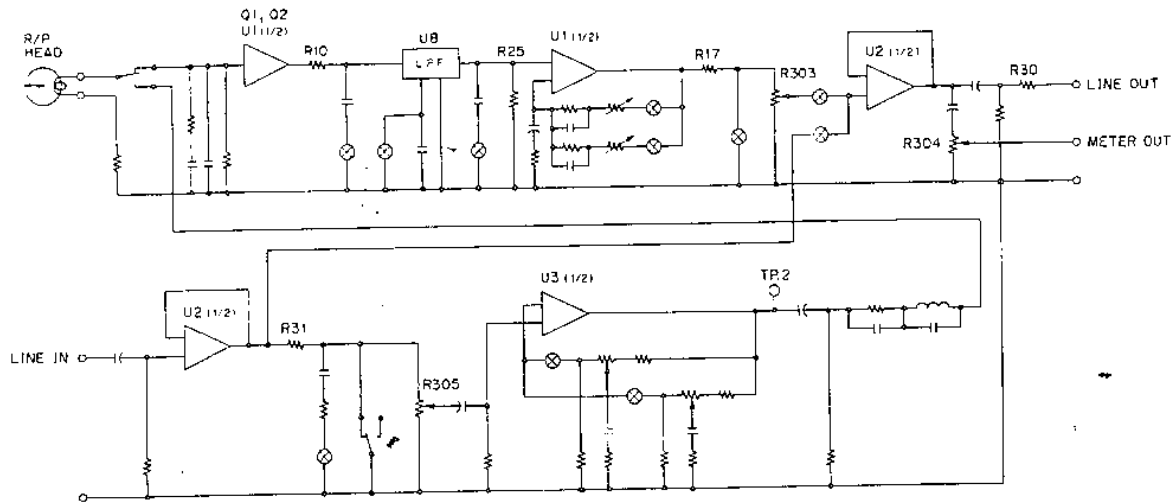

Level Diagram

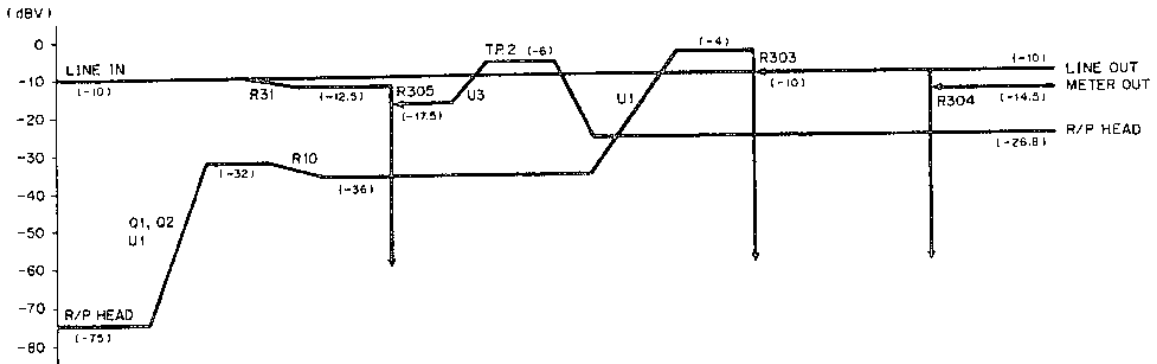

Instructions

1. UNPACKING AND INSPECTION

During unpacking, be careful not to damage the MSR-16. Save the carton and packing material as well; you may need them to transport your MSR-16 sometime in the future.

After unpacking, give the machine a complete visual inspection. If there is any evidence of damage due to rough handling during transport, it is your responsibility to notify the carrier and submit a claim.

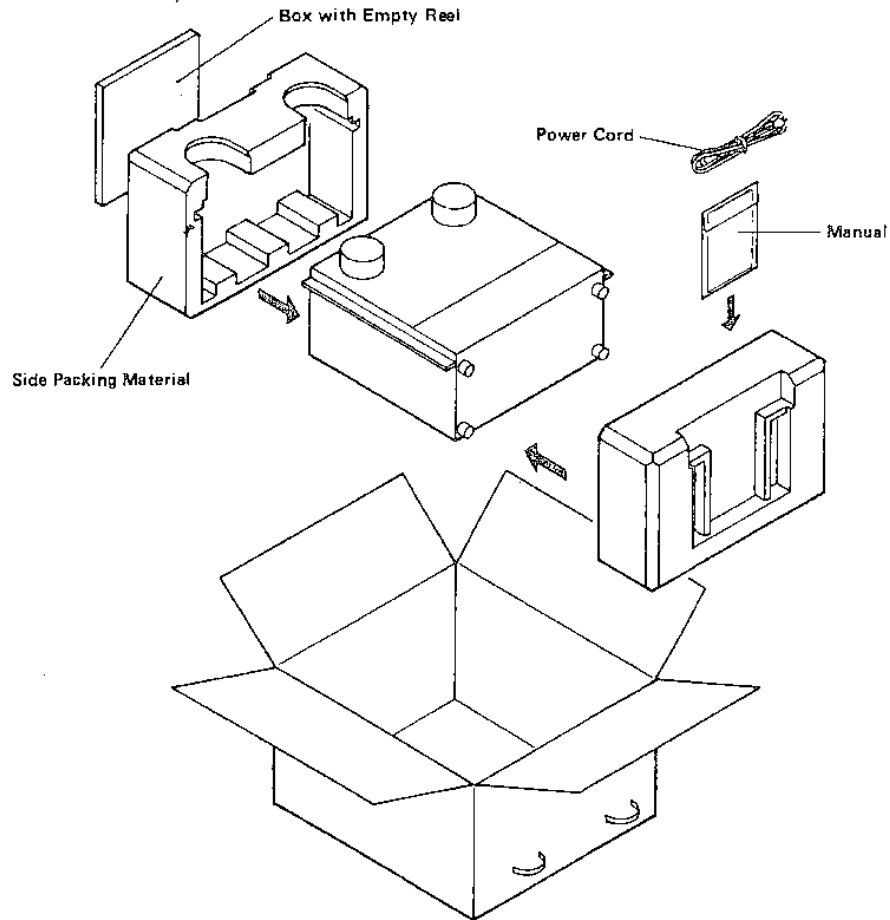

2. INSTALLATION SITE

The MSR-16 may be used in most areas, but to maintain top performance and prolong operating life, observe the following environmental limitations:

1) Nominal temperature should be 5 to 35 degrees C (41 to 95 degrees F).

2) Relative humidity should be 30 to 90% (non-condensing).

3) Strong magnetic fields should not exist nearby.

4) The fan motor grid on the machine's rear should be at least 4 inches (10 cm) apart from walls or any objects to ensure free cooling air flow.

3. RACK MOUNTING THE MSR-16

The MSR-16 may be mounted to a standard EIA 19" rack, such as the TASCAM CS-607B. Before mounting, make sure the rack you are mounting the MSR-16 to is not warped or bent. Screwing the MSR-16 to a badly warped surface may cause misalignment of the transport.

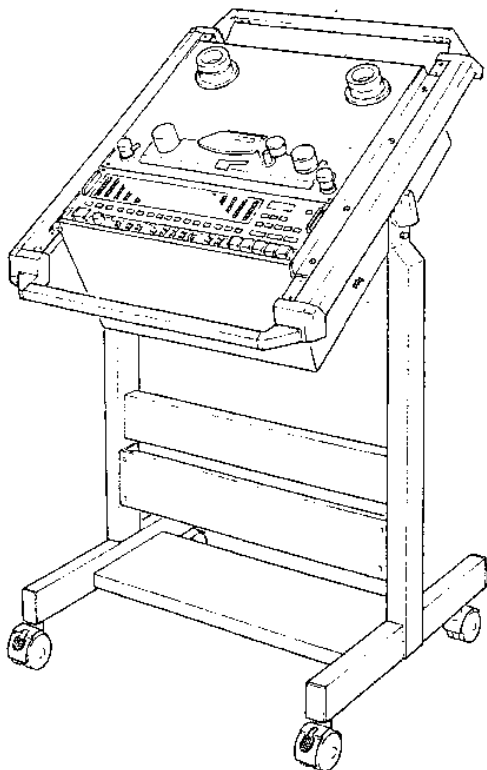

4. INITIAL CONNECTIONS

CAUTION: Before attempting any cable connection, check to make sure that all the units involved in your system are turned off.

When connecting the MSR-16 to your system, use shielded cables that are as short as your situation will allow. We recommend low-capacitance cables with quality connectors, such as the TASCAM Pro Series. Cheaper cable has less shielding and may introduce radio frequency interference, hum and noise into your system.

A. Input/Output Connections

The MSR-16's inputs and outputs are handled by RCA jacks located on the rear connector panel of the machine.

Make the appropriate cable connections to the Program busses and Tape Returns of your mixer.

If your mixer has phone jack (RCA) outputs conforming to the -10 dBV standard, the meter readings of your mixer and the MSR-16 should match, i.e., 0 VU on the mixer will read 0 dB on the MSR-16 track it's connected to. If the readings don't match, always go by the readings on the recorder.

B. AC Power Cord

Make sure of a stable, firm connection both on the MSR-16 and mains sides. Route the cord where there is no possibility of stepping on it, to prevent accidental disconnection.

C. Remote Control Connection and Computer/Synchronizer Interface

On the MSR-16's rear panel are located a REMOTE CONTROL connector and ACCESSORY 1 and 2 connectors. The REMOTE CONTROL connection makes it possible to connect the optional RC-416 remote control unit to provide remote control of all transport functions. The ACCESSORY 1 connection is a parallel port, meaning transport controls are each brought to a separate pin of the connector for external connection to the TASCAM ES-50 or other SMPTE synchronizers. The ACCESSORY 2 is a serial port, in which fewer wires carry digital messages to and from the MSR-16's microcomputer for external connection to a controlling computer with RS-232C serial data buss. It is possible to hook up a serial-capable synchronizer (such as the TASCAM MIDiiZER) to this port for control and other advanced functions. For detailed information on the use of the ACCESSORY connections, consult TASCAM or the nearest TASCAM dealer. (Also see pp. 11-14.)

5. REEL INSTALLATION

Proceed as follows:

1. Turn the holddown knob until its outer and inner three detents line up with each other.
2. Line up the three notches in the full supply reel with the three detents in the holddown knob on the supply reel table and push the reel against the reel table.
3. Turn the holddown knob fully clockwise until it is firmly seated in place.
4. Repeat the procedure for the empty takeup reel.

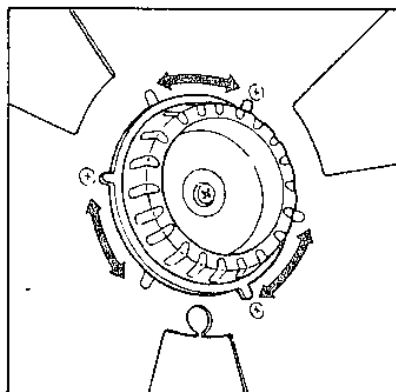

NOTE: Before running tape, make sure that the reel holddown knob is tight on both the supply and takeup reels.

6. TAPE THREADING

1. Press the Head Shield (head gate) downward toward the plate. It will latch down, revealing the heads.
2. Thread the tape exactly as shown below.
3. Replace the head shield by pressing it down lightly (it will unlatch).

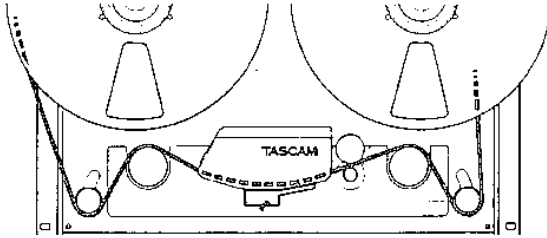

"ACCESSORY 1" PARALLEL CONNECTOR

SMPTE/EBU Time Code

SMPTE is an acronym for the Society of Motion Picture and Television Engineers. The SMPTE Time Code (C98.12: time and control code for video and audio tape for 525/30 television system) was defined in 1970, and it is now accepted as a universal standard.

This reference is to an 80-bit digital code developed by SMPTE and used to designate the exact location in hours, minutes, seconds and frames (24 frames/sec. for film or 30 frames/sec. for video) on a film, video tape, or audio tape. Suitable equipment can synchronize ("lock up") two or more machines by using the SMPTE time code recorded on each.

SMPTE European Standard, that refers to 25 frames per second, states the EBU (abbrev. for European Broadcasting Union) time code when it is especially necessary to distinguish from the USA Standard with 30 frames per second.

A *time code generator* is used to record SMPTE code onto one track of the tape. A *time code controller* can then read the code from two or more tape machines, and by also servo-controlling the reel motors of those machines, bring them to specific cue points. A *time code synchronizer* further controls the capstan motors to keep both of the tape machines running synchronously. These techniques can be used to obtain more tracks for recording (two or more audio machines "locked up" together), to mix audio signals in sync with video or film images, to make complex edits by transferring material from one or more audio machines to another, and so forth.

Connecting a Synchronizer to the TASCAM MSR-16

Connection between the ES-50 synchronizer/ES-51 edit controller and the MSR-16 is a plug-and-go proposition. Pre-wired interface cables needed are available from TASCAM.

The TASCAM MSR-16 provides signals to the synchronizer (via the ACCESSORY "1" connector) which indicate its speed, the direction of the tape travel, and a reference power supply. Also, tally signals indicating the MSR-16's mode (PLAY, F. FWD, REW, STOP) are given to the synchronizer so it knows the current transport status. Inputs on the same ACCESSORY "1" connector are provided for status commands from the synchronizer (PLAY, F.FWD, REW, STOP, REC, LIFTER CONT). Also, there is an input for a capstan drive reference frequency signal from the synchronizer so that the actual record/play speed can be varied to maintain synchronization.

The MSR-16 will also operate satisfactorily with a variety of other manufacturers' synchronizer/controllers. The manual for these products should provide you with enough interface information for use with the TASCAM tape machines. Or else, consult the synchronizer manufacturer for further details on interfacing.

Pin Assignment (ACCESSORY 1)

Pin =	IN(put)-OUT(put) signals	Function
1	PLAY IN	Inputs PLAY signal at L level.
2	FF IN	Inputs FF signal at L level.
3	REW IN	Inputs REW signal at L level.
4	open terminal	
5	STOP IN	Inputs STOP signal at L level.
6	REC IN	Inputs REC signal at L level.
7	LIFTER CONT IN	Inputs LIFTER shift cancellation signal at L level.
8	open terminal	
9	UP/DOWN OUT	Outputs tape running control signal at H or L level.
10	CP OUT	Outputs open-collector signal (12 Hz pulse at 15 ips.)
11	PLAY TALLY OUT	Outputs open-collector signal (Low level during PLAY mode.)
12	FF TALLY OUT	Outputs open-collector signal (Low level during FF mode.)
13	REW TALLY OUT	Outputs open-collector signal (Low level during REW mode.)
14	STOP TALLY OUT	Outputs open-collector signal (Low level during STOP mode.)
15	REC TALLY OUT	Outputs open-collector signal (Low level during record mode)
16	SHUT-OFF TALLY OUT	Outputs open-collector signal (Low level during tape stop)
17	open terminal	
18	open terminal	
19	REW COMMAND OUT	Outputs open-collector signal (Low level when REW is pressed)
20	FF COMMAND OUT	Outputs open-collector signal (Low level when F. FWD is pressed)

Pin =	IN(put)-OUT(put) signals	Function
21	PLAY COMMAND OUT	Outputs open-collector signal (Low level when PLAY is pressed)
22	STOP COMMAND OUT	Outputs open-collector signal (Low level when STOP is pressed)
23	REC COMMAND OUT	Outputs open-collector signal (Low level when REC is pressed)
24	RHEARSAL MODE IN	Accepts Rehearsal enabling signal coming from a properly equipped external control unit (low level with Rehearsal In)
25		
26		
27	open terminal	
28		
29		
30		
31	EXT FREQ IN (HOT)	Inputs speed control signal at input signal of 3.0 V or more and of 4.8 k to 19.2 kHz (HOT side)
32	EXT FREQ IN (COLD)	Inputs speed control signal (COLD side)
33	INT/EXT IN	Inputs internal/external speed control select signal Internal: HIGH level External: LOW level
34	open terminal	
35	+15 V supply voltage OUT	Maximum: 50 mA
36	Main unit GND	
37	+5 V supply voltage OUT	Maximum: 50 mA

USE OF THE RS-232C SERIAL INTERFACE PORT (ACCESSORY 2)

The MSR-16 operates to its full potential when interfaced with the MIDiZER, an intelligent, highly versatile serial synchronizer, which provides a link between SMPTE/EBU based audio/video production and MIDI music creation. It shifts between time code and MIDI data to constantly adapt the MSR-16 and other associated machines/units to ever changing requirements of each application.

Specifically, advanced functions the MIDiZER provides access to include Record On/Off Programming (up to 16 individual tracks), 20-point Autolocation, Synchronization either referenced to time code addresses or to MIDI coded bar numbers, Time code/MIDI data triggered events, MIDI Program Change which can be controlled with time code too, a "Total Time" function which accommodates your program material to the required length by automatically changing the tempo, and more. (Complete, update information about the MIDiZER will be made available no later than its upcoming release.)

The method of communications performed in compliance with the RS-232C standard differ depending on the mechanical/electrical characteristics and system programs of the associated machines/devices, and a small error in communications thwarts the interfaced system and even causes this to run "wild." For detailed technical information about the use of the MSR-16's Serial Port, consult TASCAM or your local TASCAM dealer.

VOLTAGE CONVERSION

NOTE: Voltage conversion is not possible on models sold in the U.S.A., Canada, U.K., Australia or Europe.

For general export models, if the input voltage specified on the MSR-16 or packing carton differs from the line voltage at the installation site, please request your dealer to change the voltage setting of the machine. The procedure entails the opening of the machine.

NOTE FOR U.K. CUSTOMERS

As the colours of the wires in the mains lead of this apparatus may not correspond with the coloured markings identifying the terminals in your plug proceed as follows:

The wire which is coloured GREEN-and-YELLOW must be connected to the terminal in the plug which is marked by the letter E or by the safety earth symbol  or coloured GREEN or GREEN-and-YELLOW.

The wire which is coloured BLUE must be connected to the terminal which is marked with the letter N or coloured BLACK.

The wire which is coloured BROWN must be connected to the terminal which is marked with the letter L or coloured RED.

IMPORTANT

THE WIRES IN THE MAINS LEAD ARE
COLOURED IN ACCORDANCE WITH THE
FOLLOWING CODE:

GREEN-AND-
YELLOW: EARTH
BLUE: NEUTRAL
BROWN: LIVE

**WARNING: THIS APPARATUS MUST BE
EARTHED.**

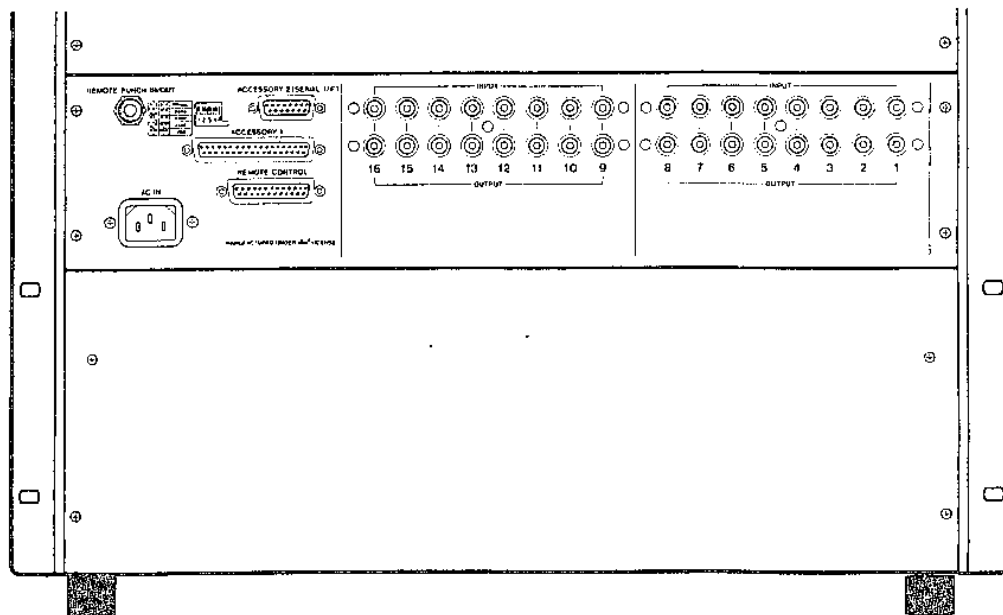
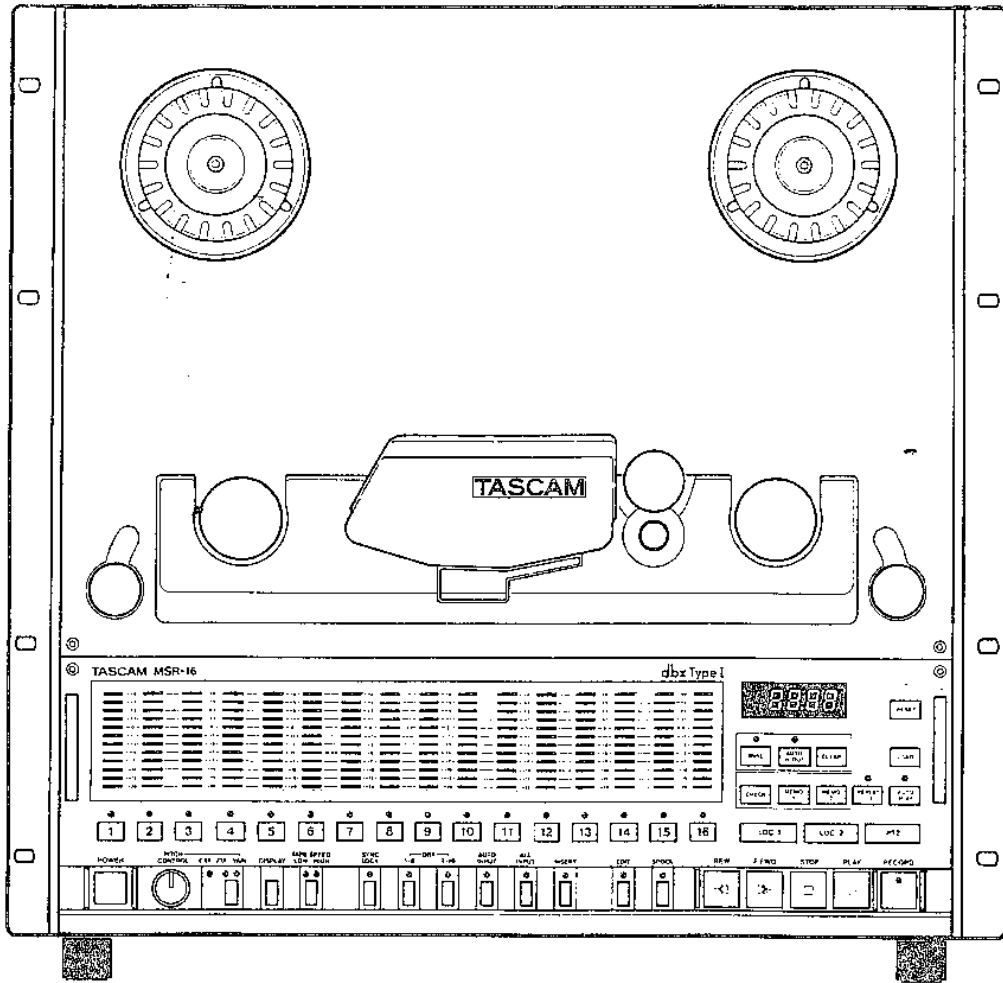

Operation

1. SETTING THE RECORD LEVEL

The MSR-16 does not utilize its own controls for setting the volume or "level" of the signal to be recorded. Therefore the recording level is adjusted on the mixer. The basic procedure for setting the record level is as follows:

1. Consult your mixer manual for information about setting its Input Trims, Faders, EQ's, and other controls that have an effect on the output level of the mixer. Set these controls to their nominal levels on the mixer.

2. Switch power on to the MSR-16. The digital counter will indicate "-88.8.8" for a few seconds as the machine's logic circuits initialize, then the display will change to "00.00."

3. Press the Record Enable button for a track being fed by the mixer output.

4. Play an instrument (or speak into a mic). While you are doing this, watch the meter on the mixer and the track's LED meter on the MSR-16. At the loudest point, both meters should peak at the reference level of "0." If not, adjust the level of the source.

2. SETTING THE MONITOR LEVEL

The monitoring of both the recorded material as well as the source during the recording process is accomplished through the mixer's monitor section. Refer to the mixer's manual for the correct procedure in setting up the monitoring system.

3. RECORDING THE FIRST TRACK

When all necessary level adjustments on your mixer are complete, you can go ahead with your recording. As an example, we will assume that you wish to use Track #1 as a rhythm track.

1. If the MSR-16 is not on, press the POWER switch.

2. Check to see that the Speed Mode selector switch is set to its FIX position and its green LED is on solid. If not, set it to FIX.

3. Set the TAPE SPEED selector switch to HIGH for 15 ips (38 cm/s) or to LOW for 7.5 ips (19 cm/s), as desired.



4. To prevent the tape from rewinding off the takeup reel during later operation, play the tape 30 seconds or so from the beginning of the tape. Press RESET and while holding it press the LOAD button. The current point on the tape is put into the MSR-16's memory system. This point, regardless of whether you later reset the zero point elsewhere on the tape, is set as an automatic STOP point so you can't accidentally rewind off the reel. (Alternatively, you can use the LOAD feature to set a STOP point near the end of the tape so the tape does not unintentionally F.FWD off the supply reel.)

5. Press the Record Enable button for track #1 (track we use only as an example). A red LED will begin flashing on and off above the track's Record Enable button.

6. Press and hold down the Master RECORD button. While still holding RECORD down, press the PLAY button. The tape will begin moving in its forward direction and recording is now in progress on Track #1. The RECORD LED should light solid and the LED above the track's Record Enable button that was flashing should also now be on solid.

7. When you have finished with recording, press STOP to terminate the recording. The RECORD LED will turn off and the track's LED will begin flashing as before.

8. Press the "RTZ" (Return to Zero) button. The tape will rewind, automatically stopping at counter zero point.

In the following illustrations,  shows a blinking LED, and  a steadily lit LED.

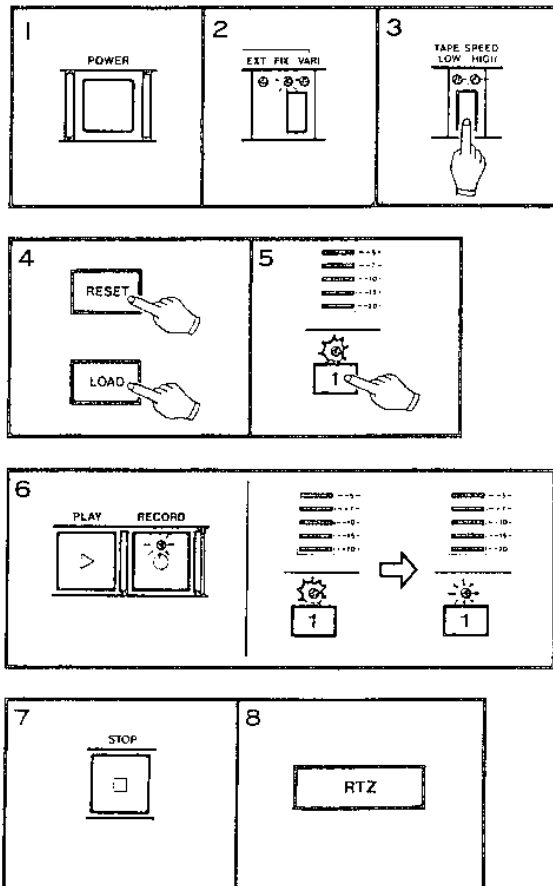

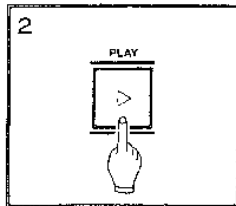
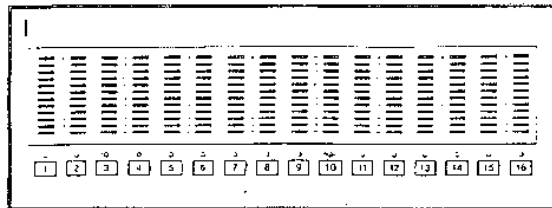

First Playback

1. Release the Track 1 Record button by pressing it. Its blinking LED will go out showing that Track #1 is now in "safety" status. Check to make sure that all other tracks are also in "safety" status with their LEDs off.

2. Press PLAY. The track you just recorded can be listened (monitored) through the mixer.

If you are not satisfied with your first take and want to re-record it (therby erasing the first take), all you have to do is:

- a) Make any changes that occured to you while you listened to the first playback.
- b) Press RTZ to rewind the tape to 00.00.
- c) Press the Track 1 Record Enable button.
- d) Press RECORD and PLAY together and try again.

Once you have a basic track you're satisfied with, you are ready to move on to overdubbing.

4. OVERDUBBING

There are two tasks in overdubbing. First, the new signals must be adjusted for proper level going to the MSR-16, as in tracking. Second, you must make a proper monitoring mix of the existing track(s). Here is a basic overdubbing procedure:

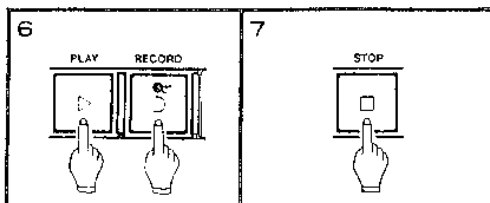
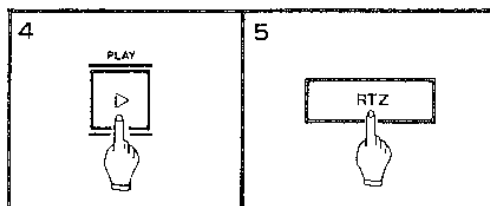
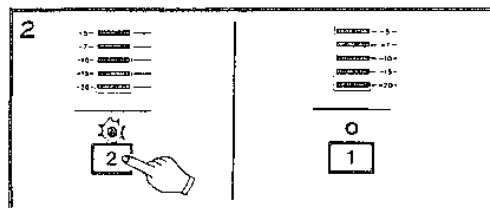

1. Select an open track for the overdub: Since we assume, in our example, that you have recorded your first take on track 1, you can choose any other track for the overdub. Factors affecting which track you choose include how many total parts you will record, and whether you plan to bounce ("ping-pong") tracks later. In this example, we'll assume that you choose track 2.

2. Place the track in record ready mode: Press the Record Enable button for track 2. Its LED will start blinking. Make sure that previously recorded tracks (such as track 1 in our example) are in safe mode so you don't accidentally erase them.

3. Adjust the recording level of the new sources using your mixer controls, watching the meter level on track 2.

4. Play the tape and adjust monitor levels for a proper balance of the incoming new signal with the signal being played back from track 1 in your headphones or monitor.

5. Rehearse your overdub until you feel confident that your levels are correct. Rewind to 00.00 by pressing RTZ.

6. Record the first overdub by pressing RECORD and PLAY.

7. Stop the recording by pressing STOP (or PLAY).

8. To listen to playback of the overdub, press the track 2's record enable button (to place the track in safe mode), then rewind to the beginning of the take and hit PLAY.

5. PUNCH-IN OR INSERT RECORDING

The MSR-16 can manually punch in with the master RECORD button, the Track Record Enable buttons, or the optional RC-30P footswitch. You can also program the punch-in and punch-out with the REHEARSAL and AUTO IN/OUT functions so the MSR-16 automatically punches in and out for you.

Manual Punch-In

METHOD A: Punching with the master RECORD button or footswitch

1. Make the following preliminary settings:
 - a) Press the Record Enable button of the track you intend to INSERT on. Its LED will start blinking.
 - b) Press the INSERT switch. Its LED will light solid.
 - c) Adjust the recording and monitoring levels for the desired balance.

2. Press PLAY. You can use the INSERT switch to toggle the MSR-16's meter and output between source and tape. While the tape is in PLAY and INSERT is on, you'll hear tape; while tape is stopped or INSERT is off, you'll hear source.

3. When the tape reaches the desired punch-in point, press RECORD or the footswitch to start recording. The monitor switches from tape to input on that track. The master RECORD LED and Track Record LED both stay on.

4. Punch out by pressing STOP, PLAY or the footswitch.

METHOD B: Punching with the Track Record button

This method is sometimes called "rolling in record" and requires that you have a free hand.

1. After the recording and monitoring levels are set, make sure that all tracks are SAFE (no track LED blinking).

2. Press RECORD and PLAY together to start playing the tape. The RECORD LED will blink, showing that the MSR-16 is in record-ready mode.

3. Press the punch-in track's record button when the tape reaches the punch-in point. The master RECORD and track record LEDs will both light up steadily, showing that recording is taking place.

4. To punch out, press the Track Record button again (you could also press STOP or PLAY).

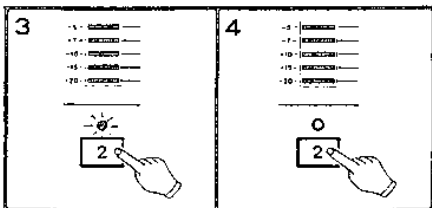
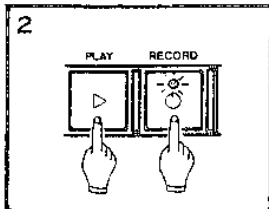
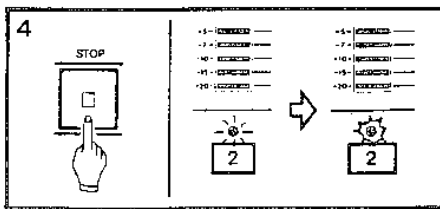
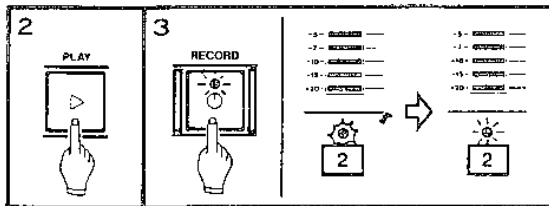

6. REHEARSAL PROGRAMMING AND AUTO IN/OUT PROCEDURES

The Auto Locator has priority over the Rehearsal and Auto In/Out modes. If LOC 1, LOC 2, REPEAT, or RTZ is pressed, the function pressed is activated erasing all the memories you have set for punch-in. The LED RHSL or AUTO IN/OUT will then blink until CLEAR is pressed.

Programmed Rehearsal of Inserts (RHSL)

Before you actually record an insert, the MSR-16 allows you to "preview" the punch-in and out points with its special REHEARSE function. During a rehearsal, the tracks in record ready mode will switch

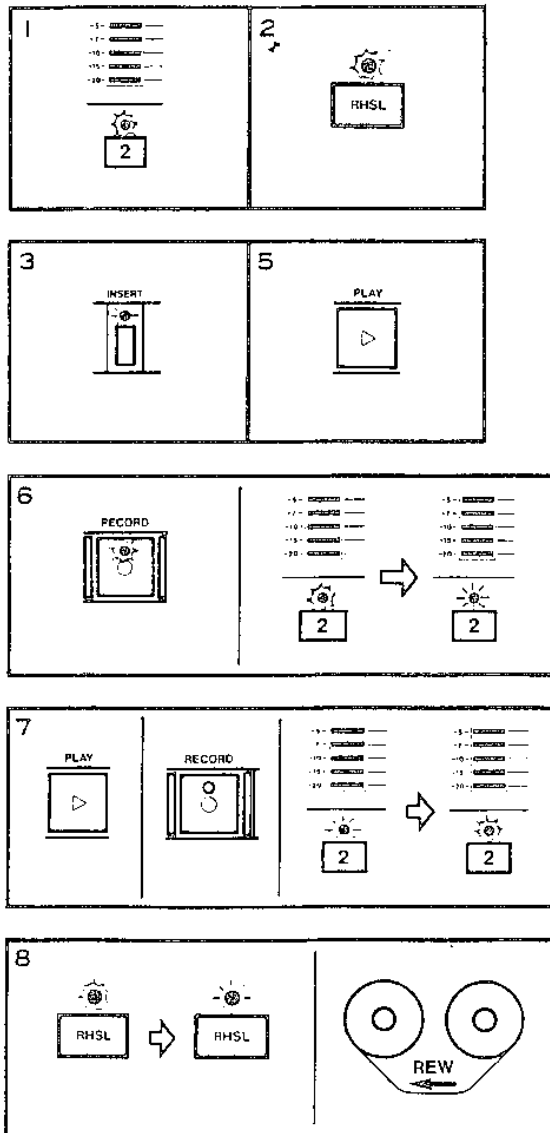

meter and output from tape to source and back again, but won't actually record. What you hear in your monitor mix will be the same as during recording; so if the first in-out points aren't correct, you'll hear it and can CLEAR the old points and try again until you've got exactly what you want.

CAUTION: Although the advanced circuitry of the MSR-16 allows gapless punch-in on the tape, there is still the distance between the erase and record heads to be compensated for. Depending on tape speed, the time from a punch point to the actual in/out is 1/15th or 1/8th of a second. A few practice runs will get you accustomed to the timing of punching in.

Entering the Automatic Preroll and Punch-In/Out Points

NOTE: If you want to quit what you are doing at any time during the following procedures, press CLEAR.

1. Press the Record Enable button of the track you want to punch-in on. Its LED will start blinking. Check to make sure that all other tracks are in safe mode.

2. Press the RHSL switch. Its LED will begin blinking. As long as this light blinks (or stays on solid as it will do later, in step 8), you can't actually record, even though the master RECORD and track's Record LEDs may go on solid.

3. Press the INSERT switch. Its LED will light.

4. Adjust the record and monitoring levels for the desired balance.

5. Press PLAY. That point on the tape will be put into memory defined as the preroll start point.

6. At the punch-in point, press RECORD or the footswitch. Your punch-in point will be put into memory. The track's record LED will light steadily, but the master RECORD LED will blink, showing that recording is not actually taking place.

7. Press PLAY or the footswitch when the tape reaches the punch-out point. That point will be put into memory. The LED for the selected track will start blinking and the RECORD LED will turn off.

8. After a 3-second postroll, the RHSL LED will go on solid, while the tape will automatically rewind, stopping at the preset start point. The MSR-16 is now in Rehearsal Ready mode.

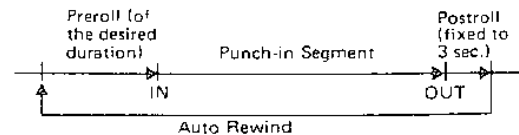

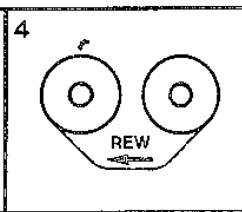
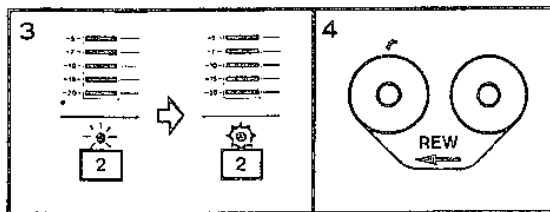
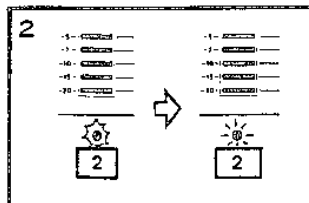
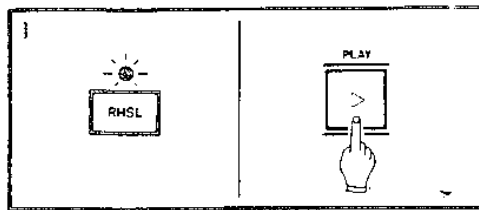

Rehearsing the Punch-in ("Dry Run")

1. Make sure that the MSR-16 is in "Rehearsal Ready" mode with the punch-in and out points memorized and the RHSL LED on solid. Press PLAY or the RC-30P footswitch. The MSR-16 will begin playing from the preset start point.

2. When the tape reaches the preset punch-in point, the track's output will switch from tape to source. The LED for the punch-in track stops blinking and stays on, although recording is not yet taking place. Your live instrument can be heard from the output of the track.

3. When the tape reaches the punch-out point, the track's output will switch back from source to tape. The LED for the punch-in track will start blinking, indicating that the "dry run" record is over.

4. After a 3-second postroll, the tape will automatically rewind to the preset start point, ready for as many rehearsals as you wish.

Practice the performance until you are sure that you will get it right when actually recording. Remember, once you punch in over existing material, that original signal is erased.

Actual, Auto Punch-In

Once you're sure your performance and the punch-in/out points selected are correct, you're ready to actually record the insert. The INSERT and RHSL LEDs should still stay on. All tracks should be in SAFE except the ones you intend to record.

1. Press the AUTO IN/OUT switch. A red LED will begin blinking above the AUTO IN/OUT switch, while the RHSL LED that was on solid will turn off, indicating that the MSR-16 is switched from REHEARSAL mode to actual, automated "punch-in ready" mode.

2. Press PLAY or the footswitch to begin the pre-roll from the preset point.

3. When the tape reaches the preset punch-in point, the punch-in track will automatically enter actual record mode, and the RECORD and Track LEDs will turn on solid. New material is being recorded, erasing the original part.

4. When the tape reaches the memorized punch-out point, the MSR-16 punches out of Record. The RECORD LED will turn off and the track's LED should again be blinking.

5. After a 3-second postroll, the AUTO IN/OUT LED that was blinking will turn on solid and the tape will automatically rewind to the memorized start point.

To review the result, press PLAY or the footswitch. The tape will play the entire segment and rewind to the start point.

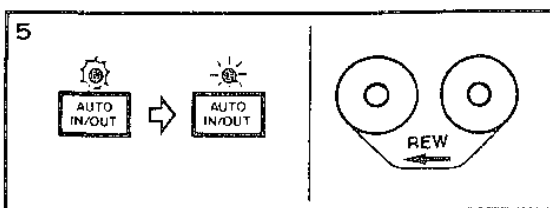
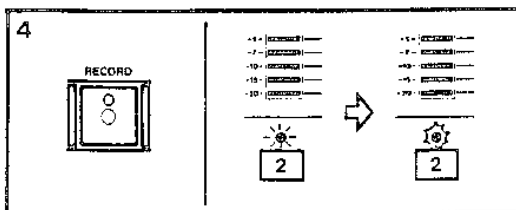
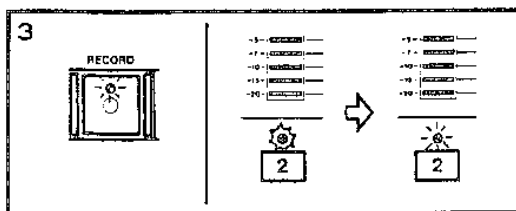
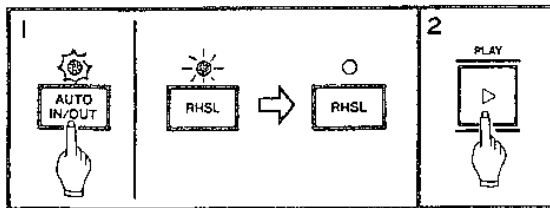

To record again using the same memory points, press the AUTO IN/OUT switch again (its LED will again blink), then press PLAY.

To terminate the Auto In/Out procedure, press the CLEAR switch. The AUTO IN/OUT LED which was on solid will turn off. By hitting CLEAR, you erase all of the three memory points (Preroll Start, Punch-in and Punch-Out points).

About Punching In

Setting in and out points: For both musical and technical reasons, when punching in or out of a track, you must select points that are "in the clear", i.e., in the pauses between phrases or notes. It sounds unnatural and makes the insert noticeable if you record a new note before the old one has ended, or are holding a note as you punch in or out. For this reason, some session players leave a beat or two of silence between passages they might want to edit later. Making inserts well requires some practice. Many engineers count bars and beats to keep track of the punch in and out points and hit them on cue. Because of the spacing between the erase and record heads, you may need to anticipate your

in/out points by a fraction of a second for extremely tight cues though the gapless operation and high speed of the MSR-16 makes it much easier.

External computer punching: If you need insert points that are consistently repeatable within 1/30th of a second, you may want to control the MSR-16 by an external computer device. With this method, track 16 is recorded with SMPTE time code and punch-in/out points are entered into the MSR-16 via the serial connector on the back panel. The procedure is similar to the MSR-16's built-in AUTO IN/OUT function but more accurate because the computer is reading a reference actually recorded on tape instead of tach pulses generated by the movement of the tape reels.

Level matching: No matter how carefully you set your punch points, if the inserted material is louder, softer, or a different tone from the original track, it will be noticeable. Set the EQ and volume settings on your mixer the same as they were during the original recording. If you make inserts immediately after recording, don't change the instrument or mixer settings at all. Keep in mind that at a certain point it's better to record the whole track over than making multiple punch-ins.

7. BOUNCING TRACKS (PING-PONG)

The recording capability of the MSR-16 is not limited to the sixteen tracks. As you progress with recording, you may reach a point where you need more than sixteen tracks of material. This is where Bouncing — also called Collapsing or Ping-ponging tracks — is invaluable. Essentially, bouncing tracks consists of a "mini mix-down": taking tracks that have already been recorded,

making a mix of these tracks and re-recording them back onto an empty track (or tracks) of the MSR-16.

With all multitrack recorders, it is possible to get feedback when a track is recording signal being bounced from the track right next to it. To eliminate feedback, it is advisable to bounce on a track away from the originals.

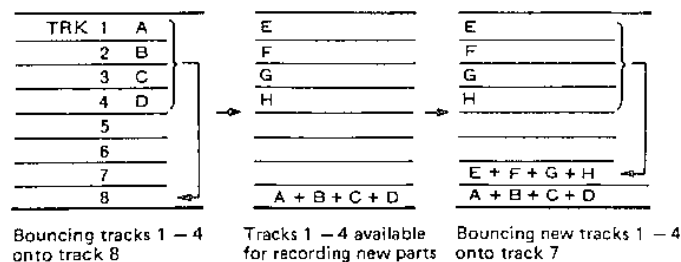

Other Tips About Bouncing

1. Before you record over the parts that have been bounced together, make certain that you're happy with the overall sound of the bounced parts, because you won't be able to change their mix or punch-in to fix errors.

2. It is possible to bounce tracks more than once, i.e., to take a bounced track and combine it yet again with other material onto another empty track. There are limits, however, just as there are anytime you make a copy of a copy. Eventually the sound will get "blurry" — treble will be decreased and added dropouts will become more noticeable. Whether the added versatility

of bouncing is worth the slight loss of sound is up to you and the demands of your project.

3. It is also possible to add new, previously unrecorded parts to the bounced material, for example to take Tracks 1-4 and mix them with additional "live" sounds onto Track 5.

4. Certain material lends itself to bouncing — vocal backgrounds, layered keyboards, etc. Main parts of the program such as lead vocals and instrumental solos are best left on their own tracks so you can control them in the final mix.

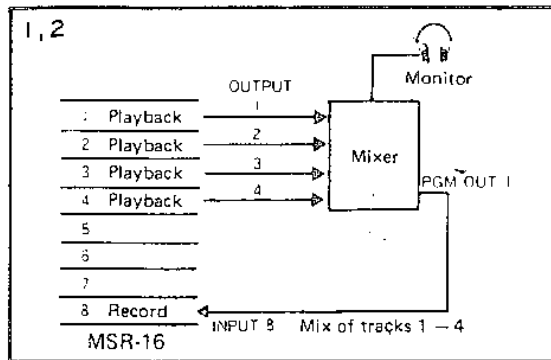

Bouncing: Example

Let's take the contents of tracks 1-4 and bounce them to track 8.

1. Set your mixer so that the main input channels 1-4 are receiving the MSR-16's tape outputs.

2. Assign channels 1-4 to the group output on the mixer connected to track 8 of the MSR-16.

3. Press the Track 8's Record Enable button (Record Ready Mode). Its LED will start blinking.

4. Make sure that the monitor section of your mixer is receiving the output from track 8 and nothing else. All other signals feeding the monitor should be turned off. This gives you an accurate monitor of the mix you're actually bouncing.

5. Start playing the tape. Slowly raise up the channel faders 1-4, and the master fader of the program group the channels are assigned to. Get the balance you want from the channel faders, then adjust the master fader for overall level until you get proper meter readings on the MSR-16.

6. Press the RTZ button to rewind the tape to counter 00.00.

7. Press PLAY and RECORD to begin recording.

8. Stop recording by pressing STOP or PLAY.

9. Press the track 8 Record button to prevent accidental erasure of the track.

10. Press RTZ then AUTO PLAY to hear the result. Make sure you've got a mix that you want to keep. If so, you're free to record over the old tracks; if not, make whatever adjustments that are necessary on your mixer and try it again.

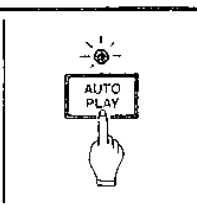
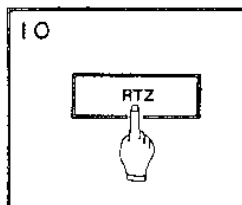
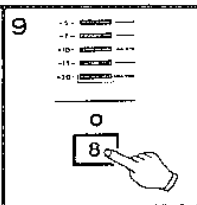
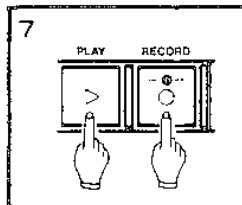
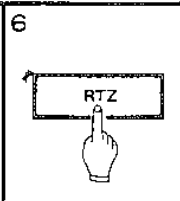
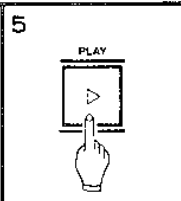
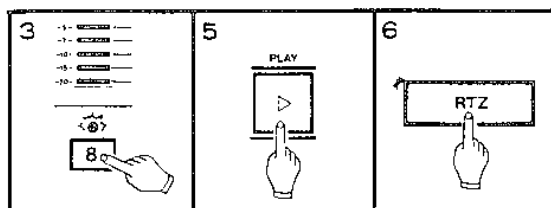

8. MIXDOWN (REMIX)

Once all the tracking and overdubbing is complete, it will be time to mixdown to stereo. At this point, the MSR-16's tracks should all be in safe mode, and the main input channels of the mixer should be switched to receive signal from the MSR-16. The stereo outputs of the mixer should be connected to your 2-track recorder, and your monitor "where from" switch should be switched to receive signal either from the 2-track outputs or the stereo output of the mixer.

NOTES:

1. If you recorded the 16-track tape with DBX noise reduction, you should play it back with DBX on. DBX is

an encode/decode process. It is not possible to get a "DBX mixdown" by defeating the noise reduction on playback, mixing encoded tracks to stereo, and then playing back the 2-track master through a DBX decoder.

2. Once outputs of the MSR-16 have been decoded by the DBX unit within the MSR-16 they behave like any other audio source, and can be mixed down to any medium: digital tape recorders, cassettes with Dolby B, C or DBX noise reduction, or the audio tracks of a VCR.

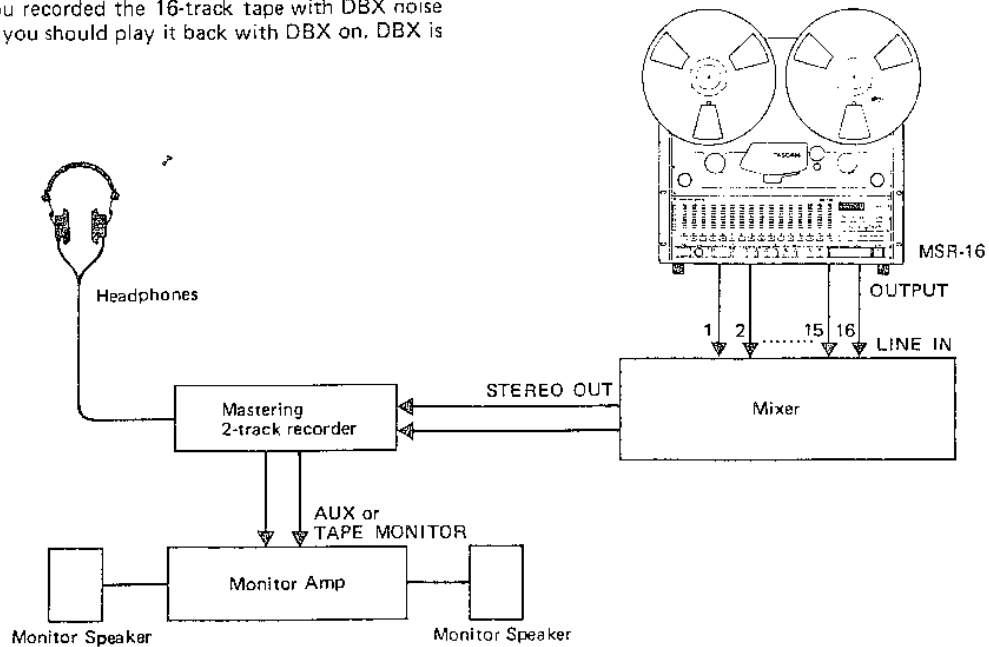

9. RECORDING WITH TAPE SYNC

Your MSR-16 has special features designed to make it an ideal recorder for use with electronic musical instruments. Track 16 is specifically designed to be used with the recordable synchronizing codes used by MIDI (Musical Instrument Digital Interface) as well as the SMPTE time code. Since MIDI itself is a computer type digital language and cannot be recorded on analog tape, it is necessary to convert MIDI timing clocks to recordable FSK (Frequency Shift Keying) signals using a MIDI/FSK converter such as the TASCAM MTS-30. Sometimes this type of converter is built into sequencers, drum machines and computer interfaces.

If you record the sync tone at the same time as instrument tracks, processing delays in some sequencers may cause phasing or timing lags during Playback. It's good practice to record the sync tone *before* recording instruments to tape.

- Connect the FSK output (labeled "Sync Out" or "Tape Out") of your sequencer, MIDI converter, or computer interface directly to the INPUT of track 16. Do not patch through your mixer. A direct connection between the sync tone generator and the

MSR-16 ensures that FSK won't accidentally leak into the audio, and unwanted audio won't leak into the FSK.

- Press on the Record Enable button of Track 16 (red LED blinking).
- Turn on the SYNC LOCK switch on the front of the MSR-16. This defeats the dbx encode/decode for track 16 only. The SYNC LOCK LED will blink.

CAUTION: Be sure to press the track 16's Record Enable button BEFORE the SYNC LOCK switch. Otherwise recording is NOT possible on that track.

- Consult the owner's manual of the device that is generating the sync tone to find out how to start the tone. Most units utilize a "pilot tone" that is output before the unit is started to help you set the level on the tape deck.
- Press RECORD and PLAY. After a few moments, hit START on your sequencer unit. Let the sequence play to its completion without stopping the MSR-16.
- Once track 16 is complete, release the Track Record button by pressing it. Its LED will go out, and the SYNC LOCK LED will go on solid showing that the track is locked to play mode.

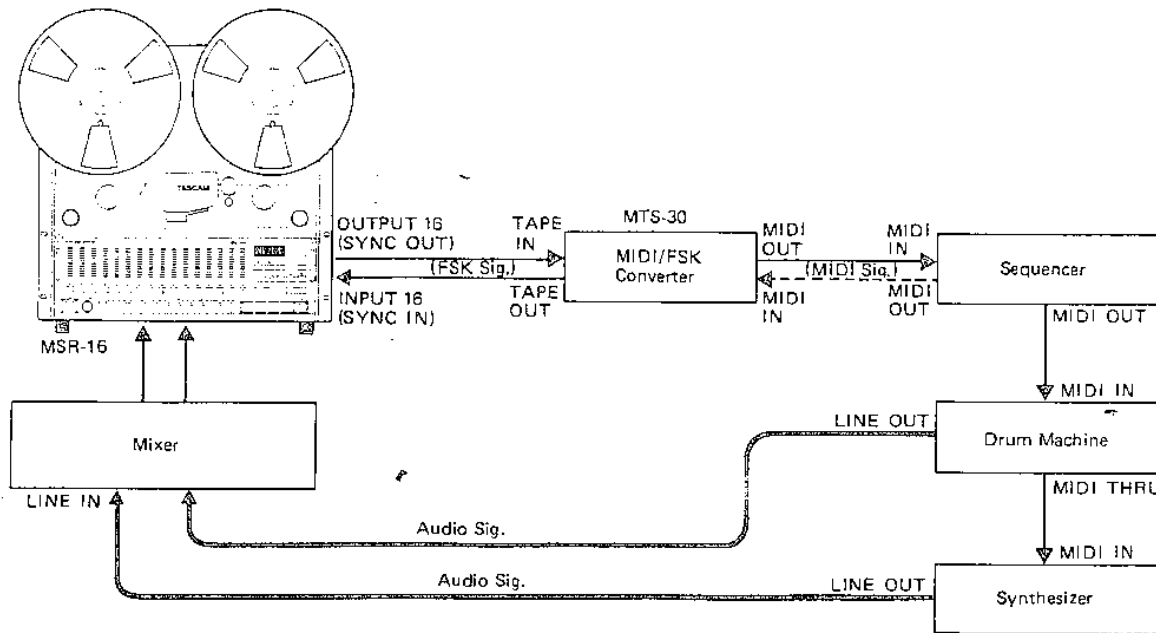

Playback of Sync Tones

- Connect the Track 16 output **directly** to the Sync in ("Tape in") of the sequencer or MIDI converter. Again, do not patch through the mixer.
- Consult the owner's manual of your sequencer unit for specifics of how to switch it to follow external tape or MIDI clocks, depending on whether you're using a MIDI/FSK adapter.
- Rewind and play the tape. The sequencer or drum machine will start at the **correct place on the tape every time and play at the same tempo** that was recorded. Or your converter will translate the sync code playing back from track 16 into MIDI clock information which, in turn, will drive the MIDI program in the sequencer or drum machine. In addition, the synthesizers and other sound sources or processors connected to the sequencer will now operate in sync with the tape. In this way you can continue to record other "non-MIDI sound sources" — vocals, acoustic instruments, etc. — on the remaining tracks while listening to the MIDI instruments playing along with the sync track 16.
By following this procedure, the sequencer in effect uses track 16 as a "guide" track to play as many instruments as are being controlled via MIDI from the sequencer, creating "virtual" tracks. You may decide to actually record the audio output of some of those tracks so you can use the instrument in a different way on another track, or you can leave the "virtual" tracks unrecorded until mixdown time. Combining virtual tracks with the normal tracking procedures used in recording makes it possible to record a tremendous number of different instrument sounds on a small number of tape tracks. Your only real limitation is the number of sound sources and the capacity of your sequencer.

About Tape Sync

- It is possible to record onto track 15 while locked to time code or sync tone from track 16 without any problem if you keep in mind that crosstalk is greatest during the overdubbing of track 15, since the record level in the head is 40 dB hotter than it is during playback. The signal of track 15 inductively crosstalks to the head windings of track 16, possibly causing a sequencer to miscue or a synchronizer to drop lock. If this happens, there are a few remedies:
 - a) Lower the record level of the signal onto Track 15.
 - b) Insert a 10 or 20 dB pad between Track 16 out and the synchronizer. There is a point with many units where the crosstalk is attenuated below the "confusion threshold" of the code reader, but there is still enough level on the time code for it to be read.
 - c) Consider recording track 15 while the virtual tracks aren't locked up. In playback, the crosstalk returns to a normal level, and you can lock up to track 16 again. If you record code and sound simultaneously, record tracks 15 and 16 at the same time ... there is no sync crosstalk if 15 is never overdubbed onto.

NOTE: Certain types of instruments — percussion or other instruments with extreme transients, synths with pulse waves, etc. — are more likely to cause a reading problem than other instruments.

Features and Controls

—REAR PANEL—

1. REMOTE PUNCH IN/OUT Jack

This is for connection of the optional RC-30P foot-switch. Whether you're a busy engineer, producer, or a musician with both hands on an instrument, there are times when you can't drop what you are doing to press RECORD button. The RC-30P is the solution. It lets you punch-in and out of Record with a tap of your foot.

2. ACCESSORY 1 Connector (37-pin, D-sub)

It has the inputs/outputs necessary for the direct interface with the TASCAM ES-50 Synchronizer or other SMPTE/EBU Synchronizers/controllers. ACCESSORY "1" is a parallel port, as opposed to the ACCESSORY "2" connector.

3. ACCESSORY 2 (SERIAL I/F) Connector (15-pin, D-sub)

This is a serial I/O port conforming to the RS-232C standard for linking the MSR-16 to an external computer, or synchronizer such as the TASCAM MIDIIZER.

The dip switch adjacent to the connector is used to select the bit rate (data transmission speed) as per the diagram beside the switch.

4. REMOTE CONTROL Connector (25-pin, D-sub)

This is for connection of the optional RC-416 remote control unit. With the remote control unit, you can control all tape motion from a distance of up to 15 ft (5 m).

5. INPUT Jacks 1-16

Each of these RCA jacks accepts a nominal input level of -10 dBV (0.316 V). The input impedance is 50 kOhms (unbalanced).

6. OUTPUT Jacks 1-16

These outputs carry either the tape signal of the corresponding track, or the source (input) signals, depending on the position of various front panel controls. See the switching logic table on page 27.

The MSR-16 has no output level controls of its own and the output level is the same as the input level; that is, -10 dBV (0.316 V). The output impedance is 100 Ohms (unbalanced).

7. AC IN Connector

For connection of the provided AC power cord.

—FRONT PANEL—

1. Reel Holddown Knobs

These are permanently mounted, and are used for the installation of large hub 10.5-inch reels. Clockwise rotation of the knobs tightens the reels in place.

2. Reel Tables

Support 10.5-inch reels/half-inch tapes. Use the same size and type of reels for both the supply and takeup sides.

3. Impedance Roller

Also referred to as "flutter filter," which insures even

tape travel across the heads and low wow and flutter performance.

4. Tension Arms

The capstan servo controls the tape tension and motor torque through the use of a position sensor attached to the right tension arm. The right tension arm is also associated with a shut-off mechanism that stops all tape motion if the tape slackens or spills off the reel. The left tension arm compensates for slight irregularities in the supply reel in addition to maintain even tape tension.

5. Capstan Shaft and Motor

The DD (Direct Drive) capstan motor is controlled by a PLL (Phase Lock Loop) servo to ensure precise tape speed.

6. Counter Roller

This measures linear tape footage, which is converted into elapsed time from whatever zero point is entered. The counter roller is associated with a tach generator to provide information about tape motion to external synchronizers during fast wind movements.

7. Pinch Roller

The MSR-16's pinch roller is a "self-centering" type for maximum tape motion consistency. A rubber coating on it is of urethane for maximum resistance both to wearing and to cracking or hardening. Also, the pinch roller is, as with all other major rotating components, supported by ball-bearings to minimize friction and retain close tolerance.

8. Head Shield (Head Gate)

Pushing this shield plate down into the plate provides a full access to the head block for tape threading and maintenance.

9. POWER Switch

Controls AC power to the MSR-16. Pressing POWER a second time turns the machine off, and clears the MEMO 1, MEMO 2, Punch-in Rehearsal (RHSL), AUTO IN/OUT, and LOAD memories.

10. LOAD Switch

This feature ensures that your tape will never run off the reel at either end. When LOAD is pressed while holding RESET pressed down, that point on the tape is put into the MSR-16's memory system. Once the LOAD point is established, the tape will stop at that point whenever it runs in REW or F.FWD. The memory point does not move even if the counter is subsequently reset to zero elsewhere on the tape.

When you wish to remove tape from the deck, simply press REW (or F.FWD) again to get past the LOAD point.

To change the LOAD point, move the tape to the desired point and press again RESET and, holding it pressed down, press LOAD.

When the MSR-16 is turned off, whatever LOAD point has been memorized is cleared from memory.

NOTE: There is only one load point; you cannot set LOAD points at the beginning and end of the tape simultaneously. Typically, set the load point 30 seconds

(to allow for overshoot) from the beginning of the reel when you're working at the start of the tape, and when you're working towards the end of a reel set LOAD about 30 seconds from the end.

11. Speed Mode Selector Switch

This switch selects either FIX or VARI mode. The setting of the switch is defeated as soon as external specific signals are fed into the MSR-16 via it's rear panel ACCESSORY 1 or 2 connector in which case the EXT LED will automatically turn on.

FIX: Locks tape speed to LOW (7.5 ips, 19 cm/s) or HIGH (15 ips, 38 cm/s) speed, as selected by the TAPE SPEED selector switch (#12). Setting to FIX is indicated by a green LED.

VARI: Switches tape speed control to the PITCH CONTROL. "Non standard" tape speeds can then be used. Setting to VARI is indicated by a red LED.

When the MSR-16 capstan motor is under external control of a synchronizer/controller the EXT LED will light steadily in yellow. When either the control signal or 9.6 kHz reference to the MSR-16 is interrupt, the EXT LED will flash and the FIX LED will turn on solid, indicating that the FIX speed mode is active, as summed up in the table below.

FIX LED	EXT LED	ACCESSORY 1 (Parallel)		ACCESSORY 2 (Serial)	
		Ext. Cont.	9.6 kHz	Ext. Cont.	9.6 kHz
On Solid	Off	None of the above four signals is coming			
On Solid	Flashing	Only one of the four signals is coming			
Off	On Solid	Either pair of the signals (control and frequency reference) is coming			

12. TAPE SPEED Selector Switch

When the switch is in its Up/HIGH position, the tape will record or play at 15 ips (38 cm/s); and when the switch is in its Down/LOW position, the tape will record or play at 7.5 ips (19 cm/s), unless the machine is in VARI or EXT speed mode.

13. PITCH CONTROL

When and only when the Speed Mode selector switch (#11) is in its VARI position and its red LED is on solid, the PITCH CONTROL is active and provides a stepless plus or minus 15% variation to the capstan motor speed both in Record and Play modes. Turn the knob to the left to lower the motor speed, or to the right to increase the motor speed. You may see a readout of the percentage of speed change using the DISPLAY switch (#14).

You can use this speed control to accomodate minor changes necessary in the length or relative pitch of your program material. If you're making a 30 second radio commercial and it runs a little long, you can speed it up enough to drop out the extra seconds, although the material on it will raise in pitch. This can sometimes be used in a creative way to save parts that are a little out-of-tune, or to create sound effects such as flanging. If you record with the PITCH CONTROL at its maximum or minimum settings, you will NOT have the ability to make further adjustment in that direction upon playback.

Also, it is recommended that you run the MSR-16 for several seconds in the play mode for the speed to

stabilize, especially when the change in speed is large. Before beginning to record again, check the pitch carefully with a short playback, and you will have less troubles with drift.

CAUTION: The PITCH CONTROL affects the record speed also. Check to make sure that TAPE SPEED select switch is set to FIX unless you are using the PITCH CONTROL intentionally.

14. DISPLAY Switch

This switch "toggles" (switches forth and back) the digital counter between "Tape Run Time" and "% of Speed Change" displays.

When the MSR-16 is initially turned on, the counter switches to Tape Run Time mode.

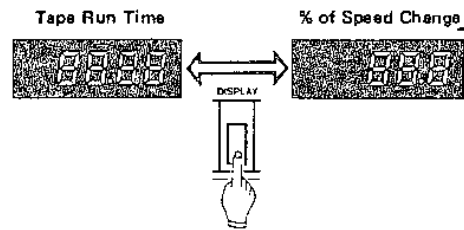

15. REW(ind) Button

Pressed, winds tape at high speed in reverse.

16. F.FWD Button

Pressed, winds tape at high speed in the forward direction.

17. STOP Button

Stops any tape motion, and cancels all transport modes.

To cancel RHSL and AUTO IN/OUT modes, use CLEAR. If STOP is used instead, the LED RHSL or AUTO IN/OUT blinks, not turns off though those functions are actually disabled, and to turn off the LED you have to press CLEAR anyway.

18. PLAY Button

a) Pressing this button alone starts tape playback.

b) Pressing the button while recording stops the recording ("punch out") without stopping the tape motion.

19. RECORD Button

Pressing the RECORD button together with the PLAY button will cause either of the following two events:

1) If any Track Record buttons are engaged, the LED above them as well as the RECORD LED will stay on, and recording will begin on the corresponding tracks.

2) If none of the Track Record buttons is engaged, the master RECORD LED will blink to indicate a record ready.

Pressing the RECORD button alone during the tape is rolling in PLAY will enable a punch-in ("insert").

The RECORD LED conveys the following messages:

A) LED off: safe mode — no recording is taking place.

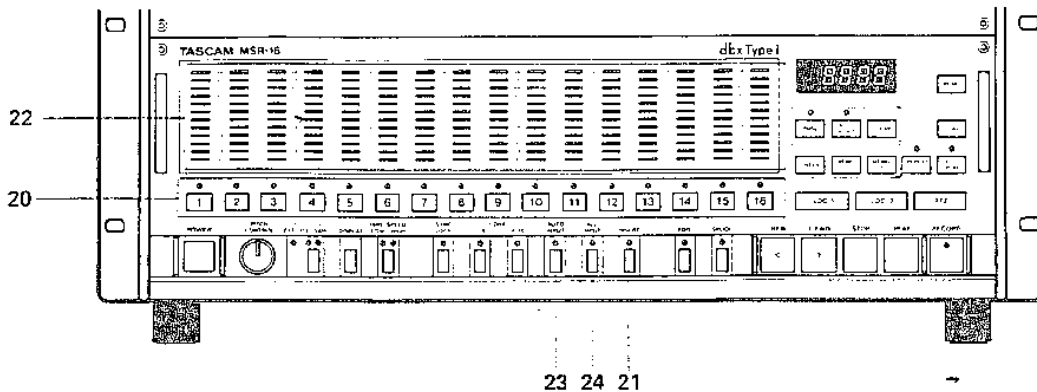

B) LED blinking: record ready mode — tape is rolling at play speed, but no actual recording is in progress. Recording will start as soon as any Track Record button or buttons are pressed on.

C) LED on solid: record mode — recording is taking place.

20. Track Record Buttons

Pressing any of these sixteen buttons puts the corresponding track into Record-Ready, or directly into Record mode if RECORD and PLAY have already been pressed.

Functions of the Track Record LEDs

A) LED off: Safe — recording cannot occur on that track.

B) LED blinking: Record Ready — recording on that track will occur when RECORD and PLAY are pressed.

C) LED on solid — recording on that track is in progress (RHSL or actual).

21. INSERT Switch

INSERT determines what signal (source or tape) appears at the output of tracks placed into record ready mode by the Track Record buttons. It allows automatic monitor switching from tape to source during punch-in, and back to tape at punch-out.

A) When insert is ON, the output of any tracks whose LEDs are blinking (in record ready mode) will be Tape.

B) When insert is ON and RECORD mode is entered (LEDs solid), the output of the tracks being recorded will be source (Input).

C) When insert is OFF, the output of any tracks whose Record Enable buttons are on will be source (Input) regardless of whether you're actually recording or not.

The INSERT button only affects tracks whose LEDs are on. When INSERT is off, you can use the Track Record buttons to manually toggle between tape and source, and rehearse a punch-in.

Switch Setting		Transport Mode		
Track Record Button	INSERT	STOP	PLAY	RECORD
ON	ON	—	Tape	Input
	OFF	Input		
OFF	/	—	Tape	

CAUTION: When performing Spot Erasures also, the INSERT switch MUST BE ON, so you can hear the output of the tape to find the erase point.

22. Peak Level Meters

These meters register the signal levels being fed to the MSR-16's OUTPUT connectors, in the limits of -20 dB to +8 dB.

23. AUTO INPUT Button

This feature automatically switches the output of tracks in REC READY mode to input during REW, F.FWD or STOP. This allows the control room to hear the talent through the tape monitor for communication, without having to change any settings on the mixer.

24. ALL INPUT Button

When ALL INPUT is pressed on, all the channels' output will carry signals derived from the input electronics regardless of the transport mode.

25. SYNC LOCK Switch

SYNC LOCK is used to "lock" track 16 to playback mode so sequencers or synchronizers can constantly read sync signals (FSK or SMPTE time codes) played back from that track. Another function the switch provides is to turn off the DBX on track 16 only, enabling sync signals to be recorded and played back without being affected by the dbx encode/decode.

When recording sync signals on track 16 be sure to press the SYNC LOCK switch AFTER the track's record enable button. A red LED will then start blinking above the SYNC LOCK switch to indicate that the DBX on track 16 is disabled.

CAUTION: If the SYNC LOCK switch is pressed

when the track 16 button is in its OFF position, the SYNC LOCK LED will turn on solid, instead of blinking, to indicate that the track is "locked", and pressing the track button has no effect and any recording can't start on that track.

Once track 16 is complete, release the track button by pressing it again. This will cause the SYNC LOCK LED that was blinking to turn on solid. As the LED is on solid, the track will NOT switch to Input, regardless of the settings of ALL INPUT or AUTO INPUT.

The track 16's status is determined by the following logic.

Switch Setting		Track 16 Status	
Record Enable Button (track 16)	SYNC LOCK Switch	Recording	DBX System
ON (LED flashing or on solid)	ON (LED flashing)	Possible or Currently in progress	Ineffective*
	OFF (LED off)	Possible	Effective or Ineffective**
OFF (LED off)	ON (LED on)	Impossible	Ineffective*

*) Regardless of the setting of the DBX switch

***) Depending on the setting of the DBX switch

26. DBX On/Off Switches, 1-8 and 9-16

When these switches are engaged, their LEDs will light and the built-in dbx noise reduction system for each group of channels (1-8 and 9-16) is turned on. This system provides a noise reduction of about 30 dB and increase of tape saturation level (headroom) of about 10 dB, resulting in a dynamic range of more than 100 dB.

When the SYNC LOCK switch is engaged, the dbx system for track 16 is disabled, as shown in the table above.

27. RHSL (Rehearsal) Button

RHSL is the first stage of an automatic punch-in recording. During Rehearsal Set mode (RHSL LED blinking), the MSR-16 memorizes the preroll, punch-in, and punch-out counter locations that are used for rehearsals and for AUTO IN/OUT.

When the desired Rehearsal points are memorized and the RHSL LED is on solid, the MSR-16 is in RHSL Ready mode, and pressing PLAY or footswitch will start a rehearsal loop. After a 3-second postroll, the tape will rewind, stopping at the preset preroll start point. The MSR-16 will again be in RHSL Ready mode. You can repeat the rehearsal sequence as many times as you wish.

In the above Rehearsal mode, the RHSL function (in combination with the INSERT feature) switches the output of tracks in record ready mode from tape to source and back again at the preset points BUT NO SIGNAL WILL BE RECORDED TO TAPE. This allows you to hear what a punch-in will sound like before you actually record it, without having to manually press any keys or footswitch.

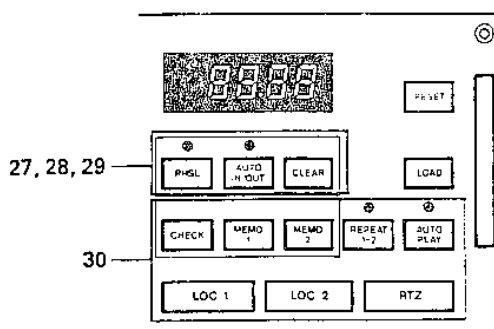

28. AUTO IN/OUT Button

After you have set the tape's preroll start, punch-in, and punch-out points in RHSL mode, entering the MSR-16's AUTO IN/OUT mode puts it into a ready status to commit the record Punch to tape. Pressing PLAY or the RC-30P footswitch initiates the actual recording by activating the automatic Punch-In/Punch-Out sequence (Preroll, Punch-In, Punch-Out and Post-roll).

29. CLEAR Button

This is used to turn off the RHSL and AUTO IN/OUT functions.

Pressing CLEAR during any other modes than RHSL and AUTO IN/OUT has no effect.

30. Auto Locator Section

Grouped to this section are the following:

- 1) MEMO 1 and 2
- 2) CHECK
- 3) LOC 1 and 2
- 4) REPEAT
- 5) RTZ
- 6) AUTO PLAY

1) MEMO 1 and MEMO 2 Buttons

These buttons are used to establish 2 autolocation points in the MSR-16's memory system. They can be used while the tape is stopped or rolling. Pressing either button at any point on the tape loads the current tape location into that memory register. Each time the button is pressed, a new MEMO point is established, erasing the previous memory in that register. Neither MEMO location can be used if the MSR-16 is in RHSL or AUTO IN/OUT mode. Both MEMO points are erased when power is turned off.

If the RESET button is pressed, and the counter is set to 00:00, the two MEMO points are automatically recalculated, so they stay the same relative to their original tape position.

2) CHECK Button

When the CHECK button is pressed, the digital counter shows a broken line. Pressing then the MEMO 1 or 2 button causes the counter to show, for as long as the MEMO button is held pressed down, the content of the corresponding register. As you release the MEMO

button, the counter again shows the broken line. A second press of CHECK, switches the counter to the original display (Tape Run Time or Speed Variation).

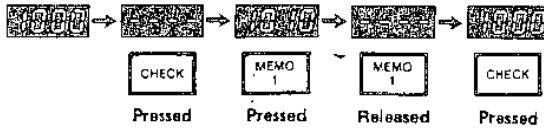

3) LOC 1 and LOC 2 Buttons

Pressing either of these buttons causes the tape to roll (in either F.FWD or REW) to the corresponding MEMO point. The tape will stop when it reaches the MEMO point. If the AUTO PLAY feature is used together, the MSR-16 will enter automatically Play mode after reaching the memorized point.

The LOC 1 and 2 buttons can safely be pressed at any time except during RHSL and AUTO IN/OUT modes; if pressed during these modes, they erase the punch-in memory points.

4) REPEAT 1-2 Button

The REPEAT function provides a "Playback Loop" or "Block Repeat" between the two programmed MEMO points. Note that MEMO 2 does NOT have to be a number greater than MEMO 1. When REPEAT is enabled and the current tape location is between the two MEMO points, the tape will play to the higher MEMO location, rewind to the lower MEMO location and start over. This cycle will repeat until STOP, or any other transport button is pressed.

If LOC or RTZ is pressed when REPEAT is on, REPEAT is cancelled and LOC or RTZ is entered, instead.

5) RTZ (Return to Zero) Button

Pressing the RTZ button will cause the MSR-16 to fast wind (FAST FORWARD or REWIND) the tape to the counter 00.00 point on the tape (even if the display isn't showing the counter). If the AUTO PLAY feature is active, the MSR-16 will automatically enter Play mode after reaching the counter zero point.

During RHSL and AUTO IN/OUT modes also, the RTZ function can be activated, but remember, the punch-in memory points are then erased.

6) AUTO PLAY Button

This feature is used together with the LOC 1 and 2 and RTZ functions. Pressing AUTO PLAY before (or after) RTZ, LOC 1 or LOC 2, will program the MSR-16 to start playback each time after it has located to the counter zero or MEMO points.

31. EDIT Button

The EDIT button provides the following five functions (all of which are disabled when STOP or any other transport buttons are pressed):

1) Manual Edit

When the transport is in STOP and the right (takeup) tension arm is in its "on" position, pressing EDIT will turn its LED on and disengage the reel motor brakes, and the same amount of torque will be exerted on both

reels. The reels may then be "hand rocked" to locate the exact edit points.

Move by hand backwards and forwards

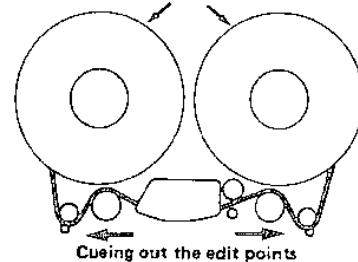

2) Stop Edit

When the transport is in STOP and the right tension arm has dropped to its "off" position, pressing EDIT will turn its LED on and disable the output mute. The tape may then be pulled forward off the supply reel as you listen to it play.

No torque exerted

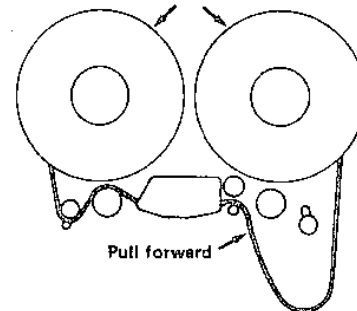

3) Dump Edit

If EDIT and PLAY are simultaneously pressed when the transport is in STOP, the EDIT LED will turn on and the tape will begin unthreading from the supply reel as you listen to it play. The right tension arm position is disregarded by the shut-off sensing logic.

Turns as in normal play mode

Doesn't turn

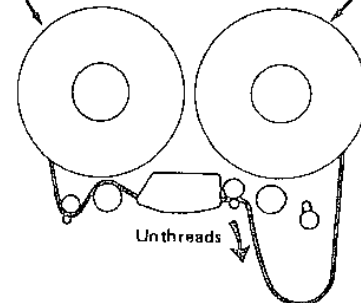

NOTE: Dump Edit can not be enabled unless EDIT and PLAY are pressed simultaneously. Pressing EDIT then PLAY only causes the tape to play normally. Pressing EDIT after PLAY has no effect; the tape continues to play.

How the dbx Works

4) Spot Erasure

This function makes it easy to erase specific portions on a given track. First, designate the track to be erased by pressing on its Record Enable button. Press INSERT so you can hear tape, enter the Manual Edit mode as explained above and "hand rock" the reels until you cue out the spot to be erased. Then back up the tape slightly so that the portion you were hearing is now at the erase head (a china marker on the tape point is helpful for this). Press and hold RECORD while slowly moving the tape by hand. Erasure continues for as long as you advance the tape with RECORD hold down.

5) Cueing

If EDIT is pressed and held down during the Fast Winding modes (including SPOOL, LOC, RTZ, and REPEAT), the tape lifters will retract so that the tape contacts the heads, enabling high-speed tape monitoring. As the cueing mode is activated, a high-cut filter is automatically inserted to prevent the meter circuits and speaker components from being damaged by high energy audio signals.

32. SPOOL Button

When the SPOOL button is pressed after (or before) REW or F.FWD, the tape will begin rolling at a constant speed of approximately 80 ips (203 cm/s) which is 1/3 times the normal fast wind speed, to obtain a tight, uniform tape pack. Generally, spooling will be done onto the takeup reel at the end of a recording or editing session so the tape can be stored "tails out", which reduces audible print-through effects (pre-echoes).

A second press of SPOOL after tape starts spooling, switches the transport to the normal fast wind mode (REW or F.FWD).

The DBX is a wide-band compression-expansion system which provides a net noise reduction (broad-band, not just hiss) of a little more than 30 dB. In addition, the compression during recording permits a net gain in tape headroom of about 10 dB.

A compression factor of 2:1 is used before recording; then, 1:2 expansion on reproduce. These compression and expansion factors are linear in decibels and allow the system to produce tape recordings with over a 100 dB dynamic range — an important feature, especially when you're making live recordings. The DBX employs RMS level sensors to eliminate compressor-expander tracking errors due to phase shifts in the tape recorder, and provides excellent transient tracking capabilities.

To achieve a large reduction in audible tape hiss, without danger of overload or high-frequency self-erasure on the tape, frequency pre-emphasis and de-emphasis are added to the signal and RMS level sensors.

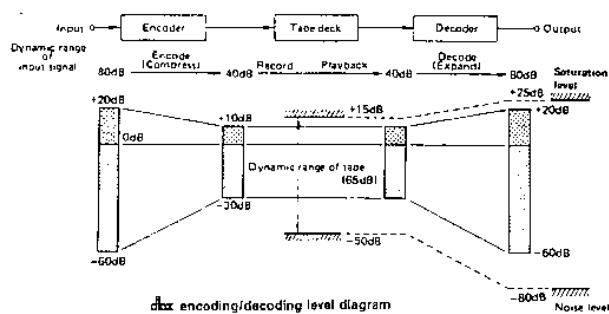

SUBSONICS AND INTERFERENCE

The DBX incorporates an effective bandpass filter. This filter suppresses undesirable subsonic frequencies to keep them from introducing errors into the encode or decode process. However, if rumble from trains or trucks is picked up by your microphone and fed to the DBX, modulation of the program material during low level passages may occur. This low-frequency component will not itself be passed through the recorder and so, will not be present at reproduce for proper decoding. If this low-level decoding error is encountered, and subsonics are suspected, we suggest the addition of a suitable high-pass filter in the Microphone Line.

Care and Maintenance

We can't stress the importance of cleaning and demagnetizing too much. Oxide shed from the tape and accumulated on the heads and other components in the tape path and dust or debris picked up from the air can result in poor high frequency response. Also, the heads may become magnetized. This residual magnetism can increase noise and distortion, significantly degrading record/reproduce performance. Clean up and demagnetize at least every day before you start to work with the MSR-16.

A clean and properly demagnetized tape recorder will maintain its performance without any other attention for quite a while. It won't ruin previously recorded material, nor will getting it back to original specifications be difficult.

CLEANING

1. Press down the head shield to get full access to the heads.
2. Apply cleaner to a cotton swab or lint-free gauze and wipe the entire surface of the tape path. Wipe off any excess cleaning fluid with a dry swab.

CAUTION: Be sure to use a good cleaner. We recommend the following:

- TEAC HC-1 (U.S. only) or TZ-261A (for heads, tape guides, impedance roller, and capstan shaft); and
- TEAC RC-1 (U.S. only) or TZ-261B (for pinch roller and counter roller).

DEGAUSSING (DEMAGNETIZING)

A little stray magnetism can become quite a big nuisance in tape recording. It only takes a small amount (.2 Gauss) to cause trouble on the record head. (Gauss is the unit used to measure magnetism.) A little more than that (.7 Gauss) will start to erase high frequency signals on previously recorded tapes. You can see that it's worth taking the trouble to degauss regularly.

DEGAUSSING IS ALWAYS DONE WITH THE RECORDER TURNED OFF. If you try it with the electronics on, the current pulses produced by the degausser will look just like audio signals to the heads. These pulses are around 10,000 Gauss, and will seriously damage the electronics and/or meters. Turn off your MSR-16, then turn on the degausser at least 1 m (3 feet) away from the recorder.

Be certain that your degausser has either a plastic cover or plastic tape covering the tip. Make sure that no metal ever touches the tape heads as it will scar them and ruin them.

Slowly move in to the tape path. Move the degausser slowly back and forth, touching lightly all metal parts in the tape path. Slowly move it away again to at least 1 m (3 feet) from the recorder before turning it off.

Be sure to concentrate while you are degaussing. Don't try to hold a conversation or think of anything else but the job you are doing. If the degausser is turned on or off by accident while it is near the heads, you may put a permanent magnetic charge on them that no amount of careful degaussing will remove. You will have to get the heads replaced. Make sure you are wide awake for this job.

Optional Equipment

RC-416 Remote Control Unit

The RC-416 has duplicates of the rehearsal/auto punch-in and auto-locator controls in addition to the basic transport controls. The cable length is 5 meters (15 ft.).

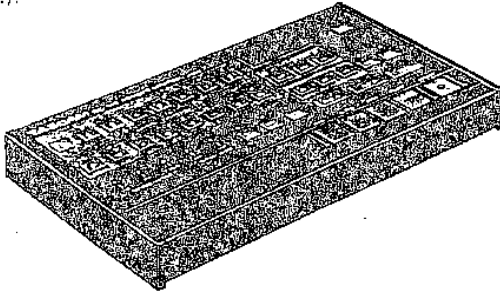

MTS-30 MIDI-Tape Synchronizer

The MTS-30 allows the MSR-16 to sync-up with the MIDI keyboards, drum machines, sequencers. Thanks to its unique "Song Pointer Sync" capability, the associated MIDI equipment will stay in sync and follow the tape no matter where you move the tape within a given song. The MTS-30 responds also to the PITCH CONTROL of the MSR-16. The maximum stability or resolution of the synchronization is ensured by the use of a newly developed, special error correction circuit.

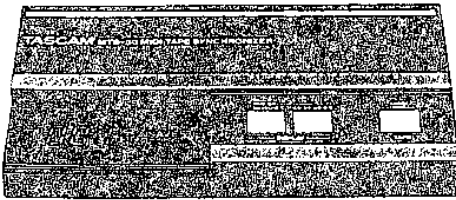

RC-30P Punch-in/out Footswitch

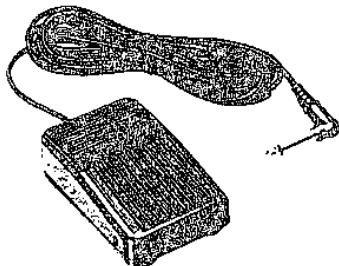

LA-40 Low-Impedance Adaptor

The LA-40 is a 4-channel low impedance adaptor which makes it possible to connect 600-Ohm balanced +4 dBm/-20 dBm XLR type connectors or 3-conductor 1/4" phone jacks to -10 dBV RCA jacks, or vice versa.

The LA-40 can be conveniently mounted on the TASCAM CS-607B or equivalent EIA standard 19-inch rack.



ES-50/ES-51 SMPTE Synchronizer/Controller

The TASCAM ES-50 can be used as either a stand alone chase lock synchronizer or with the TASCAM ES-51 edit controller, which gives access to more complex control/editing functions.

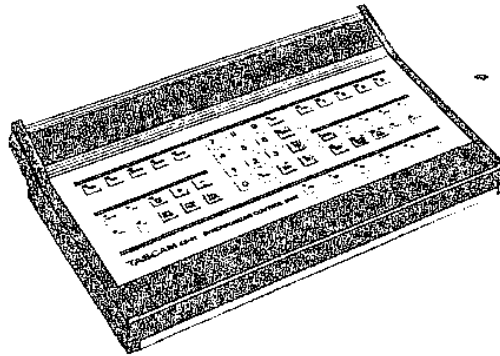
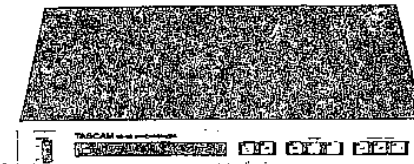

TASCAM ES-50 SYNCHRONIZER FEATURES

- * Battery backed up Auto-Calibration.
- * Newly developed high speed timecode reader LSI reads timecode from 1/20 to 100 times play speed.
- * Compatible with all SMPTE/EBU timecode standards, 29.97 fps, 30 fps, 24 fps, and 25 fps.
- * Timecode generator integrated for Re-start/Jam.
- * External Reference input.
- * Code Only Master operation.
- * DC or FM servo control available.
- * RS-232C interface port allows remote computer/editor control via serial data buss.
- * Digital servo control ensures lock stability of better than $\pm 50 \mu\text{sec}$ with most tape transports.
- * Multi-CPU distributed intelligence for faster operation.
- * All circuit functions are digitally controlled, eliminating the need for adjustments.

TASCAM ES-51 CONTROLLER FEATURES

- * Cue points can be entered into memory from the keypad or by capturing timecode numbers on the fly.
- * Master/Slave Autolocator with 20 scratchpad memories.
- * Automated Punch-In Punch-Out facilities.
- * Pre-settable End Limit points to prevent accidental tape wind off.
- * Pre-roll time is programmable from 0 frame to 36 minutes.
- * Sub-frame accurate (1/100 frame) offset trimming.
- * Five programmable timecode triggered events, including Record In/Out. Events can be entered using the keypad or on the fly.

CS-607B 19" Console Rack

(Dimensional drawings shown on the next page)

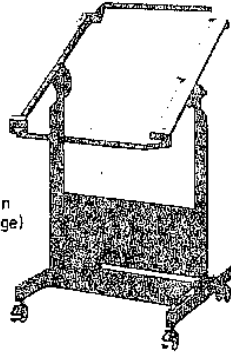

TO-122A Test Tone Oscillator

Useful for system calibration or level checks. Provides six frequencies: 40 Hz, 400 Hz, 1 kHz, 4 kHz, 10 kHz, and 15 kHz. Level is switchable between -10 dBV and -40 dBV. Also available is the TO-8 with three frequencies: 400 Hz, 6.3 kHz, and 12.5 kHz.

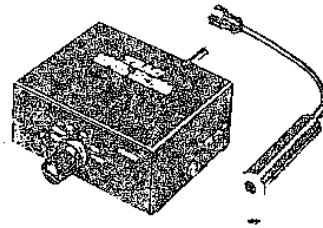

RE-1013 Metal Reel

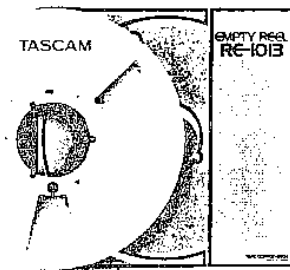

TZ-261 Cleaning Kit (Except U.S.)



E-2A Bulk Eraser

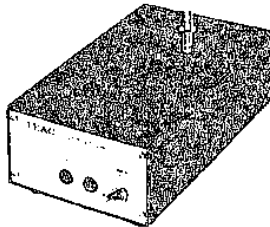

HC Head Cleaner & RC Rubber Cleaner (U.S. Only)

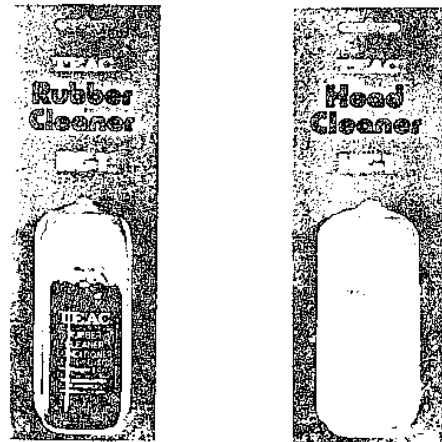

E-3 Head Demagnetizer

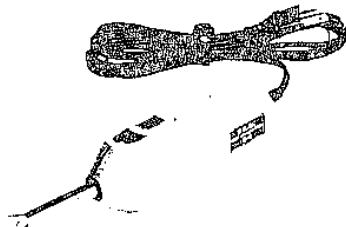

CS-607B DIMENSIONS

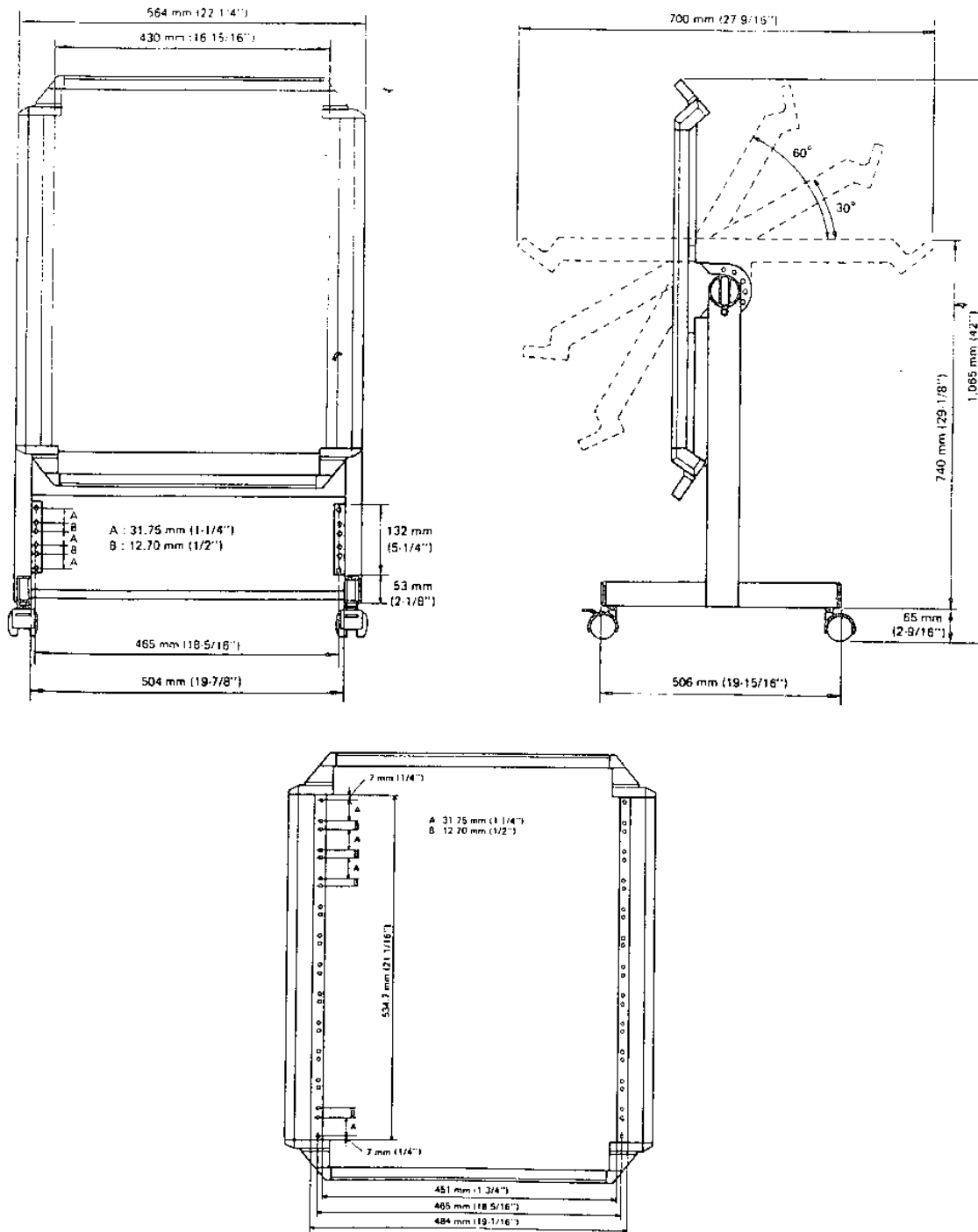

TASCAM

TEAC Professional Division

MSR-16

TEAC CORPORATION

MAIN OFFICE: 3-7, Nakacho 3-chome, Musashino, Tokyo, Japan Phone (0422) 53-1111
SALES OFFICE: 15-30, Shimorenjaku 4-chome, Mitaka, Tokyo, Japan Phone (0422) 45-7741

TEAC CORPORATION OF AMERICA

7733 Telegraph Road, Montebello, California 90640 Phone: (213) 726-0303

TEAC UK LIMITED

5 Marlin House, Marlin Meadow, The Croxley Centre, Walford, Herts., WD1 8YA, U.K.
Phone: 0923-225235

TEAC CANADA LTD.

340 Brunel Road Mississauga, Ontario L4Z 2C2, Canada Phone: 416-890-8008

TEAC AUSTRALIA PTY., LTD.

106 Bay Street, Port Melbourne Victoria 3207, Australia Phone: 646-1733

PRINTED IN JAPAN 1291U0.5-M-0111E

MAINTENANCE

CAUTION – THESE SERVICE INSTRUCTIONS ARE FOR USE BY QUALIFIED PERSONNEL ONLY. TO AVOID ELECTRIC SHOCK DO NOT PERFORM ANY SERVICING OTHER THAN THAT CONTAINED IN THE OPERATING INSTRUCTIONS UNLESS YOU ARE QUALIFIED TO DO SO. REFER ALL SERVICING TO QUALIFIED SERVICE PERSONNEL.”

INSTRUCTIONS FOR SERVICE PERSONNEL

BEFORE RETURNING APPLICANCE TO THE CUSTOMER, MAKE LEAKAGE-CURRENT OR RESISTANCE MEASUREMENTS TO DETERMINE THAT EXPOSED PARTS ARE ACCEPTABLY INSULATED FROM THE SUPPLY CIRCUIT.

NOTES

- ★ Parts marked with * require longer delivery time.
- ★ All resistors are 1/4 watt, 5 % unless marked otherwise. Resistor values are in ohms (K=1,000 ohms, M=1,000,000 ohms).
- ★ All capacitor values are in microfarads (p=pico-farads).
- ★ Δ Parts marked with this sign are safety critical components. They must always be replaced with identical components – refer to the TEAC Parts List and ensure exact replacement.
- ★ 0 dB is referenced to 1 V in this manual unless otherwise specified.
- ★ PC boards shown viewed from electro-parts side.

TABLE OF CONTENTS

1. Brief Signal Theory	4
1-1. Controls	5
1-2. Amplifiers	5
2. Voltage Conversion	5
3. Checks and Adjustments	
3-1. Parts Locations	6
3-2. Test Equipment	7
3-3. Removal of Main Parts	
3-3-1. Front trim panel	8
3-3-2. Amplifier panel	8
3-3-3. Top rear panel	8
3-3-4. Connector panel	8
3-3-5. Bottom lower rear panel	8
3-3-6. Head replacement	9
3-3-7. Capstan motor replacement	10
3-3-8. Reel motor replacement	10
3-3-9. Fuse replacement	10
3-3-10. Control PCB	11
3-3-11. DBX and capstan servo PCBs	11
3-3-12. Amplifier PCBs	11
3-4. Transport Alignment	
3-4-1. Brake mechanism	12
3-4-2. Brake torque	12
3-4-3. Pinch roller pressure	13
3-4-4. Tape tension servo	14
3-4-5. Reel table height	14
3-4-6. Tape speed	15
3-4-7. Tape travel	15
3-4-8. Wow and flutter (reproduce method)	16
3-4-9. Capstan servo	16
3-5. Audio Alignment	17
3-5-1. Preliminary procedure (Head azimuth a adjustment)	18
3-5-2. Input level check	18
3-5-3. Meter setting (input signal reading)	18
3-5-4. Reproduce level	18
3-5-5. Reproduce frequency response	19
3-5-6. Bias tuning and bias trap adjustments	19
3-5-7. Record bias adjustment	19
3-5-8. Record level	19
3-5-9. DBX IN/OUT level	20
3-5-10. Overall frequency response	20
3-5-11. Overall signal-to-noise ratio	20
3-5-12. Overall distortion check	20
3-5-13. Erasure	21
3-5-14. Channel crosstalk	21
3-5-15. Sync crosstalk	21
3-6. DBX PCB Adjustments	22
3-6-1. Adjustments location	23
3-6-2. Decoder	23
3-6-3. Encoder	23

4. PARTS LISTS	25
4-1. Mechanics	
Exploded View-1	25
Exploded View-2	27
Exploded View-3	29
Exploded View-4	31
Exploded View-5	33
Exploded View-6	35
4-2. Electronics	
Control PCB Ass'y	37/48
Operation PCB Ass'y, Mother PCB Ass'y	39/49
R/P PCB Ass'y	41/49
DBX PCB Ass'y	42/50
Power Supply PCB A Ass'y	43/50
Power Supply PCB B Ass'y	43/51
Capstan Servo PCB Ass'y	44/51
Fuse PCB Ass'y	45/52
VR/OSC PCB Ass'y, Joint PCB Ass'y, Filter PCB Ass'y	46/52
In/Out PCB Ass'y, Head PCB Ass'y	47/52
Sensor PCB L Ass'y, Sensor PCB R Ass'y, Baud Rate PCB Ass'y, PG PCB Ass'y, Shut PCB Ass'y, Diode PCB	47/53
4-3. Schematic Drawings	
Wiring Diagram	54
Control PCB Ass'y	55
R/P Amp PCB Ass'y	56
Mother PCB Ass'y	57
DBX PCB Ass'y	58
Capstan Servo PCB Ass'y	59
Operation PCB Ass'y	60
Power Supply PCB Ass'y	61
4-4. IC Internal Block Diagrams	62

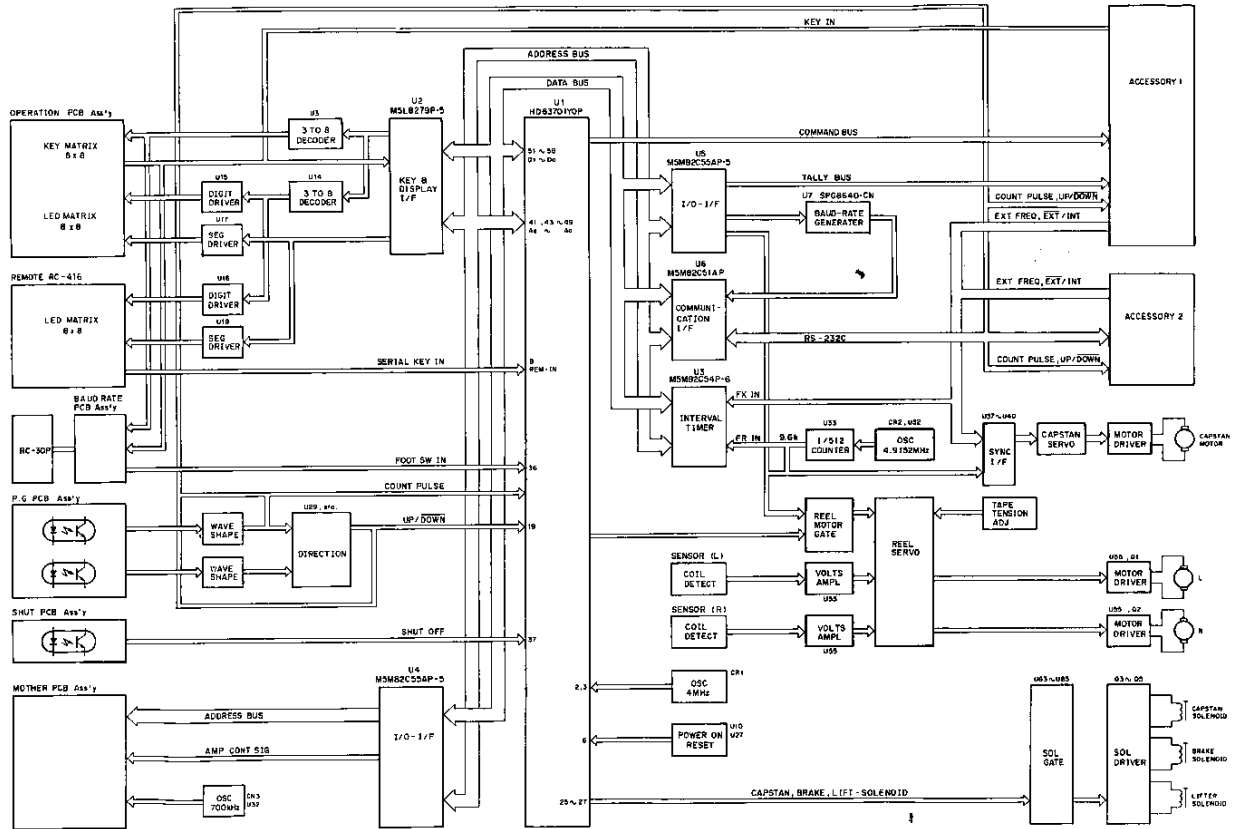

FIG. 1. CONTROL SIGNAL BLOCK DIAGRAM

1-1. Controls

Refer to the Control Signal Block Diagram and Control PCB Schematic (p. 55).

The MSR-16 uses an 8-bit micro computer U1, HD63701YOP, to control all tape motions.

Keyed-in signals are sent in parallel to U1 through the key matrix in U2. Keyed-in signals from the remote control unit are sent to pin 9 of U1 as a serial data.

In the P.G. PCB are generated two signals which have a phase difference of 90° each other. One of the two is that which serves as the tape count pulse. Advance/delay in phase occurred in the two signals yields the tape counter the UP/DOWN signal.

From the expander U4 are sent mode instructions and timing signals to the amplifier of each channel.

The ACCESSORY 1 connector (37-pin, D-sub) is a parallel interface port for connection to SMPTE synchronizers/controllers.

The ACCESSORY 2 connector (15-pin, D-sub) is a serial interface port complying with the RS-232C standard for connection to MIDI tape synchronizers or computers.

The capstan motor is controlled using the 9.6 kHz reference which is obtained by dividing by 512 the frequency signal from CR2.

Switching between VARI/FIX/EXT is controlled by the SYNC I/F circuit which is made up of U37-40.

The GATE circuit to the reel motor generates reference voltages following the switchings of the transport mode, to accordingly control the reel servo. The SENSOR circuits "watch" the tape tension and control the reel motor so the tape runs with the optimum tension in whatever mode the transport may be.

1-2. Amplifiers

Refer to the R/P AMPL PCB Schematic (p. 56).

The MSR-16's electronics are controlled by the U6, μ PD7554CS-100, micro computer.

U6 decodes serial data from the control circuits and transmits the following signals:

(Outputs from pins 12 through 16 are active at LOW.)

Pin 5	AISO	Switches the monitor output to INPUT or SYNC. When the pin goes L, INPUT is selected.
Pin 6	AHLD	This is a tape speed signal and used to select the record/reproduce equalizers and cut-off frequencies of LPF (U8), and optimize record bias. The pin goes L when the tape speed is set to 38 cm/s.
Pin 7	ANFO	Sends out a signal controlling the on/off switching of the dbx system. At L, the dbx turns on.
Pin 8	AMTO	Sends out the play mute on/off signal. The mute is disabled as the pin goes L.
Pin 12	ARB	Controls the record bias start/stop.
Pin 13	ARRL	Energizes the record relay (K1) which is used to switch the R/P head functions and release the record mute.
Pin 14	AEC	Controls the erase current start/stop.
Pin 15	AERL	Energizes the erase relay (K2).
Pin 16	SE	Sends out the spot erase signal.

The gapless punch-in/out is controlled by the timing of the above ARB, ARRL, AEC and AERL signals. The circuit made up of U3 (2/2), R43-49, and C33-37, is a sync crosstalk cancel circuit which is activated when one channel is in record and any other channels are in playback, to defeat record signals leaking onto the playback channels. The CANCEL 1 and 2 signals have effect on directly surrounding playback tracks (channels), and the CANCEL 3 and 4 on the next far away surrounding playback tracks (channels).

2. VOLTAGE CONVERSION

NOTE: This voltage conversion is only possible on general export models and NOT on models sold in the U.S.A., Canada, U.K., Australia, or Europe.

Proceed as follows:

1. Make sure that the power cord is unplugged.
2. Remove the top upper rear panel by removing four screws on the rear upper.
3. Locate the voltage selector where indicated in the illustration below and pull off the selector plug (the center shaded square piece) to reinsert it so that the arrow on it points at the required voltage values.
4. Replace the top upper rear panel and fully tighten the four screws.

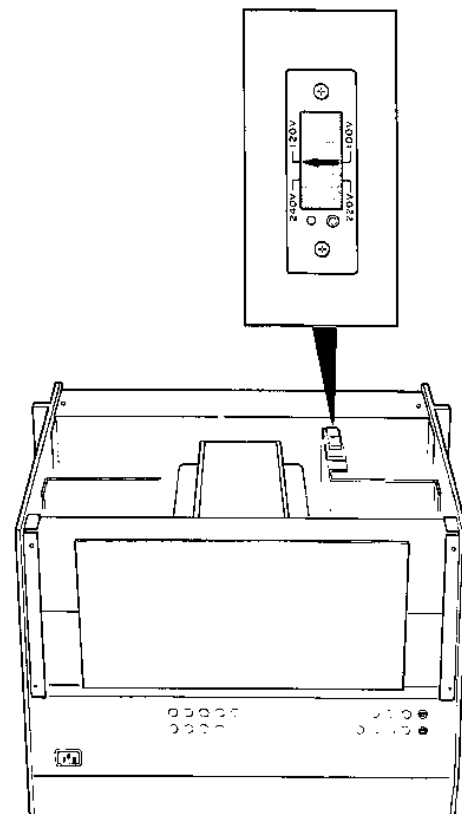

FIG. 2. VOLTAGE CONVERSION

3. CHECKS AND ADJUSTMENTS

3-1. Parts Locations

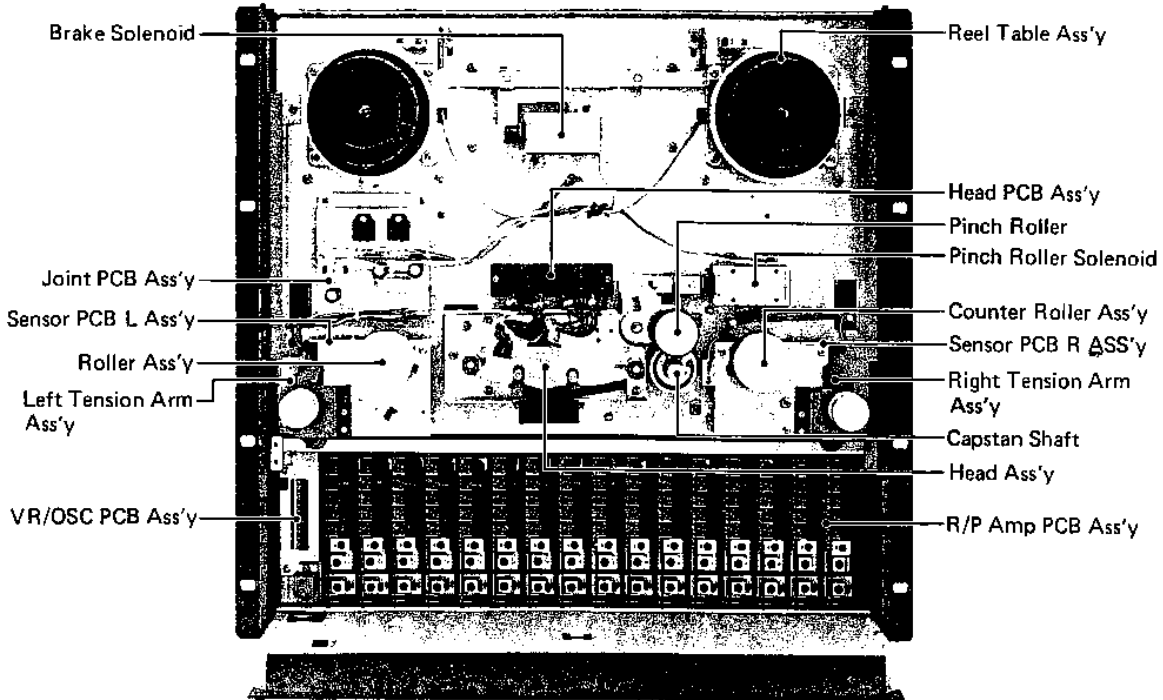

FIG. 3. WITH THE FRONT AND AMPLIFIER PANELS REMOVED

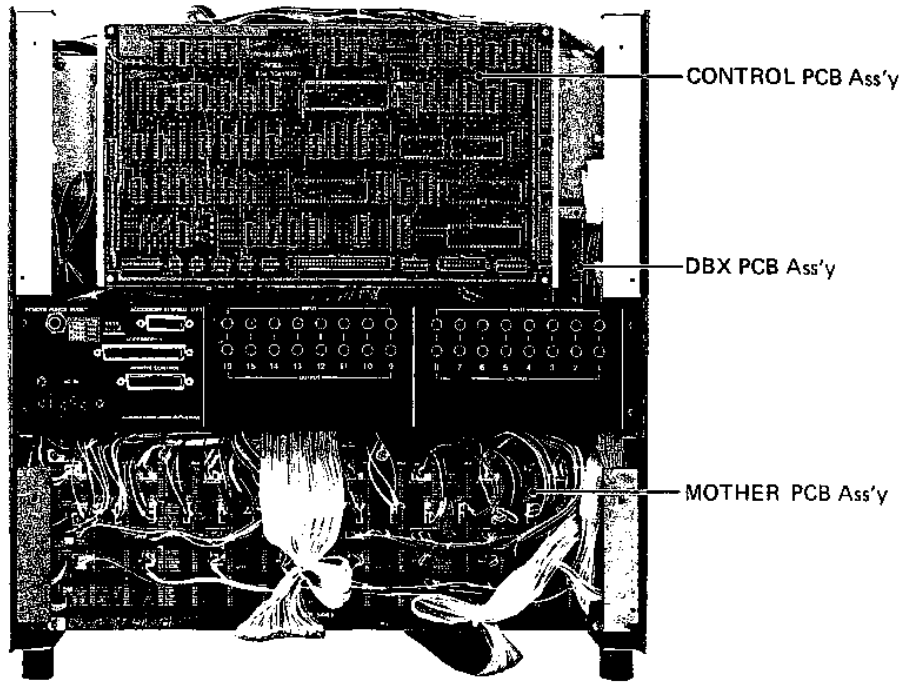

FIG. 4. WITH THE REAR PANELS REMOVED

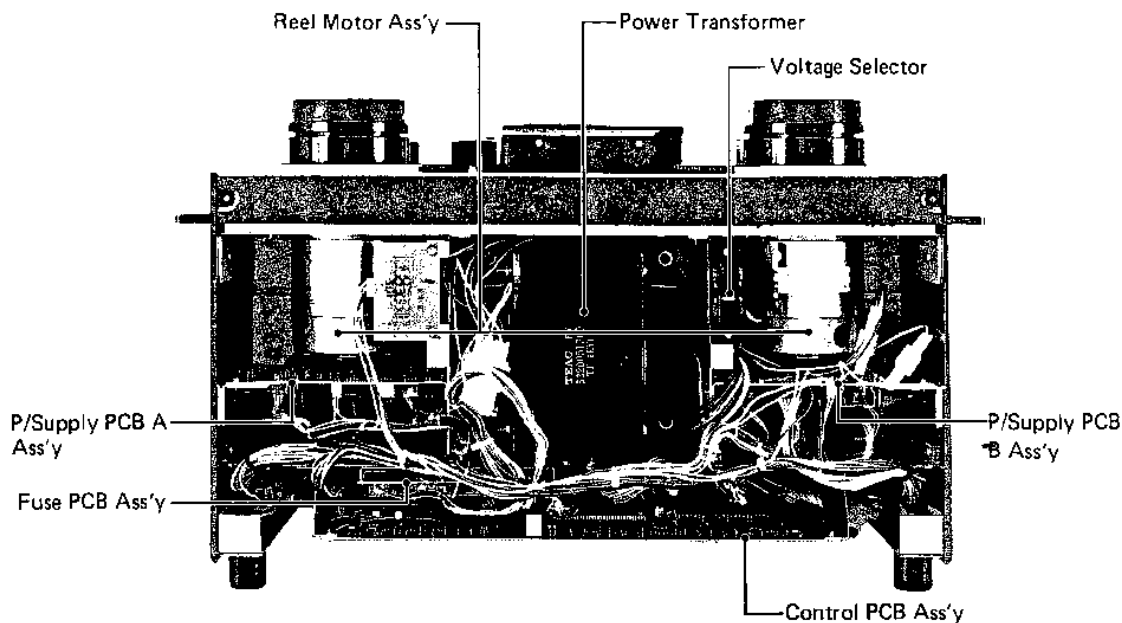

FIG. 5. BENEATH THE TRANSPORT

3-2. Test Equipment

Wow & flutter meter	Meguro Denpa Sokki K.K., Model MK-668C or MK-669 (JAPAN), or Mincom Division, 3M Co, Model 8155 (U.S.A.)
Audio oscillator	Hewlett Packard, Model 204C or equivalent
Digital frequency counter	Range: 10 Hz ~ 1 MHz; sensitivity: 0.1 Vrms; imp.: > 1 M Ω , < 25 pF
Band-pass filter	1 kHz narrow band pass type
AF level meter	Range: -80 dB ~ +40 dB; imp.: > 1 M Ω , < 25 pF (example—HP 400GL)
Distortion meter	General purpose (400 Hz, 1 kHz)
Oscilloscope	General purpose
Attenuator	General purpose
Tools	Spring scale: 0 ~ 8 lbs (0 ~ 4 kg) 0 ~ 2.2 lbs (0 ~ 1 kg) Hex head Allen wrenches, Plastic alignment tool
Cleaning fluid:	TEAC TZ-261 or equivalent TEAC Spindle Oil TZ-255 or equivalent TEAC E-3 or equivalent
Head demagnetizer	
Test tapes	Reproduce Alignment Test Tape: TEAC YTT-11442 (for 15 ips) TEAC YTT-1143 (for 7.5 ips) Equalization Standard.: IEC, CCIR. Time Constant: 15 ips = ∞ μ s + 35 μ s. Wow and Flutter Test Tape TEAC YTT-2104 (for 15 ips) TEAC YTT-2103 (for 7.5 ips) Blank Test Tape (Recording) TEAC YTT-8163.

3-3. Removal of Mains Parts

WARNING! TO AVOID ELECTRIC SHOCK, BE SURE TO UNPLUG POWER CORD PRIOR TO REMOVING OR REPLACING ANY PARTS.

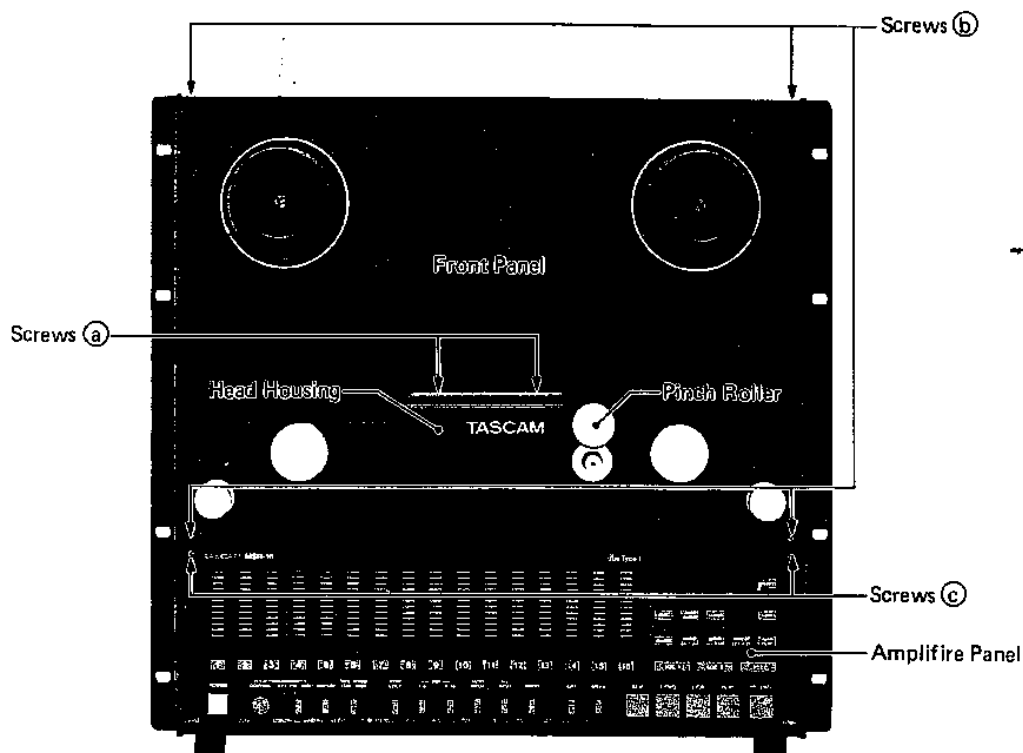

FIG. 6. FRONT VIEW

3-3-1. Front trim panel

CAUTION: When removing hex head screws in the following procedure, use care not to lose washers under them.

1. Remove the head housing by removing the two hex head screws marked (a) in Fig. 6.
2. Remove the pinch roller by removing the retaining screw in the top center of the roller (counterclock rotation).
3. Remove the four hex head screws marked (b) in Fig. 6.

3-3-2. Amplifier panel

Remove the two hex head screws (c) in Fig. 6 and the amplifier panel can be opened by pulling it toward you.

The amplifier panel need be opened when performing tape tension and pitch control adjustments, in addition to amplifier adjustments.

3-3-3. Top rear panel

Remove the four screws (d) shown in Fig. 7 (two of them holding the feet), then pull the top rear panel toward you off the chassis.

3-3-4. Connector panel

Remove the four screws (e) shown in Fig. 7 and the panel can be opened by pulling that toward you.

3-3-5. Bottom lower rear panel

Remove the four screws (f) shown in Fig. 7 (two of them holding the feet), and pull the panel toward you off the chassis.

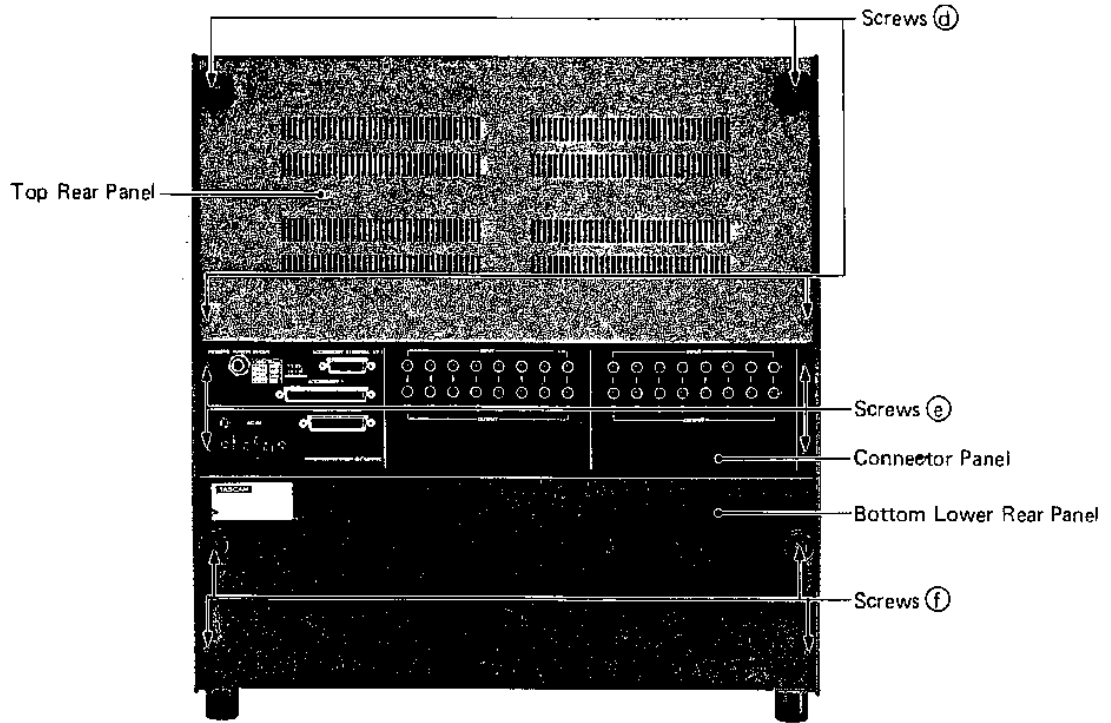

FIG. 7. REAR VIEW

3-3-6. Head replacement

Degradation of erasure or frequency response due to excessive head wear necessitates replacing the erase or rec/repo heads.

1. Remove the head housing, pinch roller cap, pinch roller and front panel, in this order, as in paragraph 3-3-1.
2. Unplug the connectors, remove the three screws marked (a) in Fig. 8, then remove the head assembly.
3. Remove the two azimuth adjustment screws (c) from the rec/repro head and the four hex head screws (b) from under the head base, to remove the individual heads.

NOTE: The erase head is "fixed", there is no adjustment, and is held in place with two mount screws ("b") only, while the rec/repro head is "semi-fixed" and has two azimuth adjustment screws ("c"); there is no necessity of adjusting its zenith (tilt).

After replacing erase head, rec/repro head or head assembly, the following must be performed:

- 1) Tape travel check (paragraph 3-4-7)
- 2) Head azimuth adjustment (rec/repro head only) (paragraph 3-5-1)
- 3) Electrical adjustments (Section 3-5)

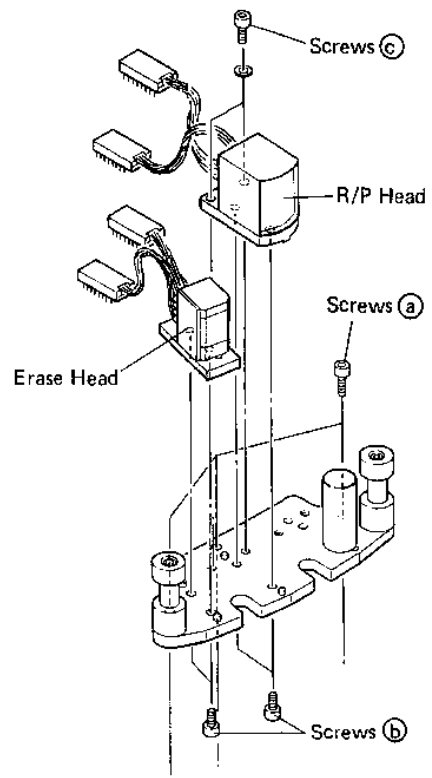

FIG. 8. HEAD REMOVAL

3-3-7. Capstan motor replacement

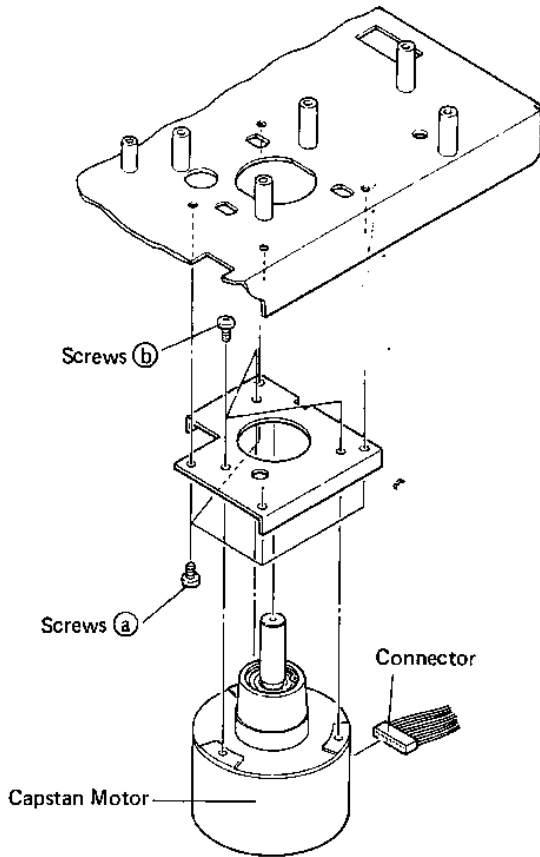

FIG. 9. CAPSTAN REMOVAL

1. Remove the rear connector panel and unplug the connector from the capstan motor.
2. Remove the four (a) screws.
3. Remove the three (b) screws and remove the capstan motor.

After replacing capstan motor, check the following:

- 1) Capstan servo (paragraph 3-4-9)
- 2) Tape speed (paragraph 3-4-6)
- 3) Wow and flutter (paragraph 3-4-8)

3-3-8. Reel motor replacement

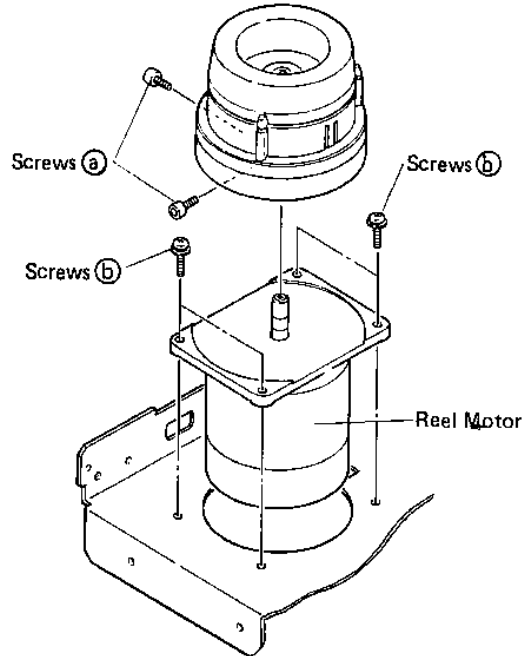

FIG. 10. REEL MOTOR REMOVAL

1. Remove the head housing, pinch roller cap, pinch roller and front panel, in this order, as in paragraph 3-3-1.
2. Remove the two (a) screws, then remove the reel table from the motor shaft.
3. Remove the four (b) screws, then remove the reel motor.

3-3-9. Fuse replacement

When fuses have blown, fix the problem before replacing them.

CAUTION: When replacing fuses, make sure that the power cord is unplugged. Be sure also to use fuses with the same specifications as the originals.

To get to the fuses, pull the control PCB toward you by referring to paragraph 3-3-10.

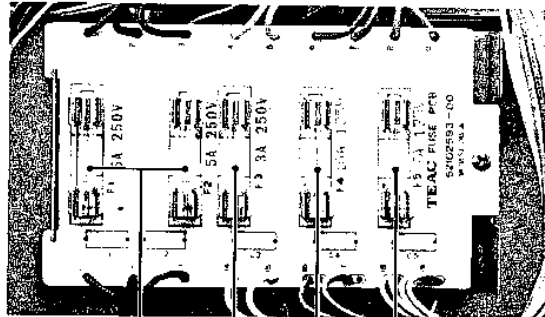

FIG. 11. FUSES

- F5 (Regulated +5 V Control, VU, Amplifire, +12 V Reel Motor)
- F4 (Regulated +11 V VU, Regulated +12 V Relay, SOL, +24 V Reel Motor)
- F3 (Regulated +24 V Cap, Servo, Regulated +15 V Control)
- F1, F2 (Regulated +12 V, -12 V Bias, Amplifier, dbx)

3-3-10. Control PCB

Remove the two screws shown in Fig. 12, slide the control PCB assembly up, then pull the assembly toward you as shown in Fig. 13.

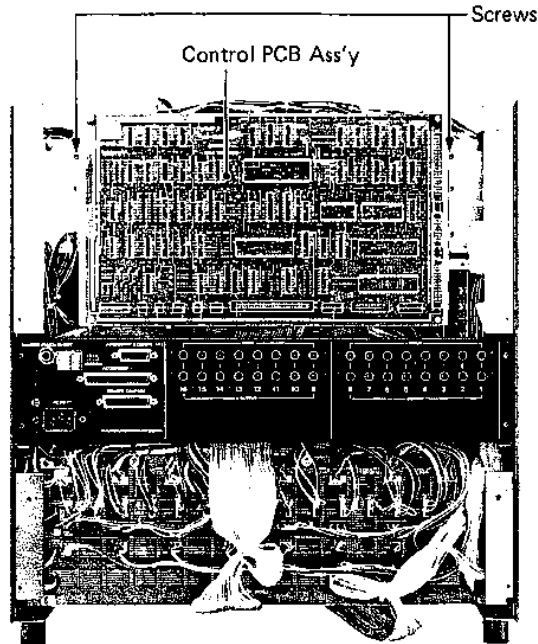

FIG. 12. CONTROL PCB INSIDE THE TOP REAR PANEL

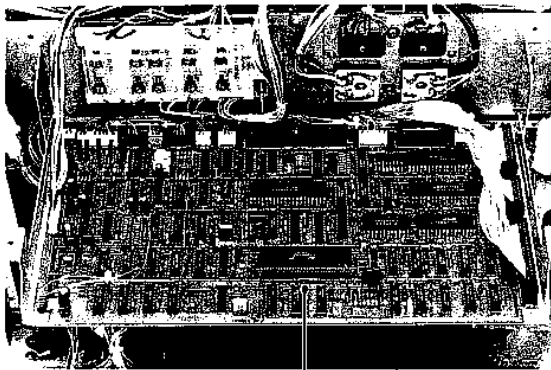

FIG. 13. CONTROL PCB PULLED TOWARD YOU

3-3-11. DBX and capstan servo PCBs

1. Remove the connector panel (see 3-3-4) and top rear panel (3-3-3), then slide the control PCB up (3-3-10).
2. Loosen the three screws shown in Fig. 14, and slide the holder plate until the cutouts in the plate line up with the PCB cards so these can be slid out.

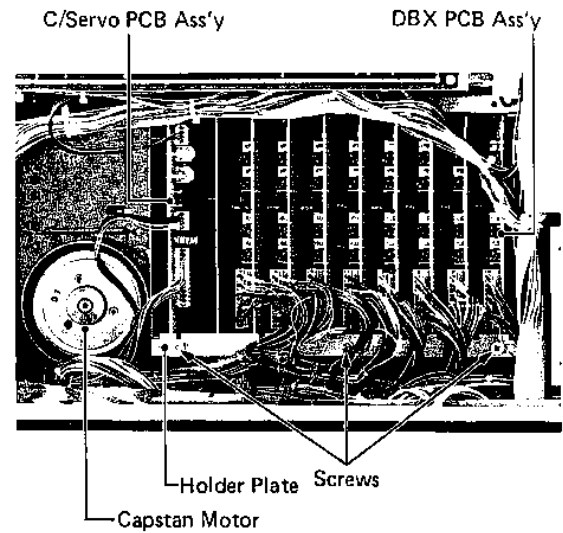

FIG. 14. REMOVAL OF DBX & CAPSTAN SERVO PCB CARDS

3-3-12. Amplifier PCBs

Remove the amplifier panel (see 3-3-2), then use the provided "card puller" (a hook) to withdraw the amplifier PCB cards.

3-4. Transport Alignment

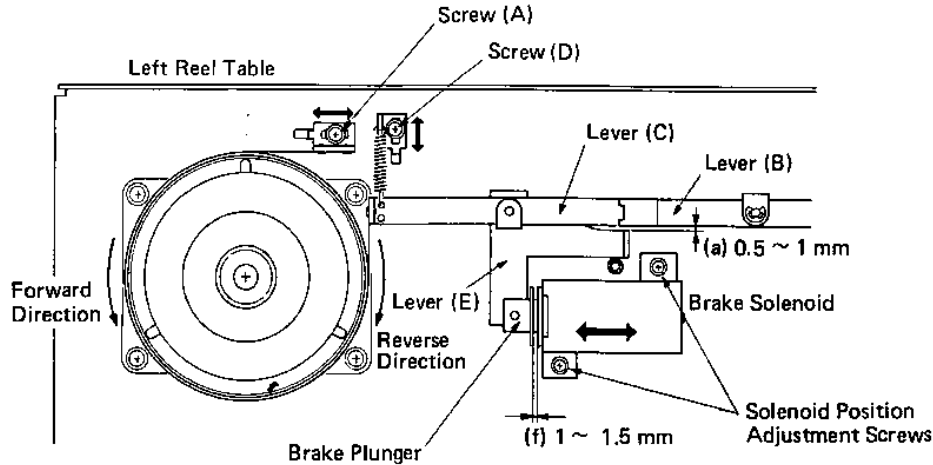

FIG. 15. BRAKE MECHANISM & TORQUE ADJUSTMENTS

3-4-1. Brake mechanism

CAUTION: Make sure that no power is applied to the deck before performing the following.

1. Refer to Fig. 15 and adjust screw (A) so clearance (a) is within 0.5 and 1 mm. If adjusting the (A) screw does not provide any clearance, it will be necessary to move the brake solenoid until gap (f) (plunger and washer distance) is within 1 and 1.5 mm.
2. Adjust screw (A) of the right brake assembly (not shown in the figure) so lever (B) is parallel to lever (C).

3-4-2. Brake torque

CAUTION: Make sure that no power is applied to the deck before performing the following.

1. Mount an empty 10-1/2" reel onto either reel table and attach a spring scale to the reel with a string. See Fig. 16.
2. Smoothly pull the scale away from the reel under test and note the torque value when the reading on the scale is steady. Take the four measurements A through D shown in Fig. 16. The proper torque values are shown below the figure.
3. If forward brake torque is not within specifications, adjust the spring hanger hooking position by loosening screw (D) shown in Fig. 15. If this adjustment has no effect or
4. If reverse brake torque does not meet specifications, perform the following:
 - a) After cleaning brake belt inner side with an alcohol cleaning solution, replace brake felt pad with a new one.
 - b) Recheck brake mechanism, paragraph 3-4-1.

If the above procedure has no effect, replace reel table(s).

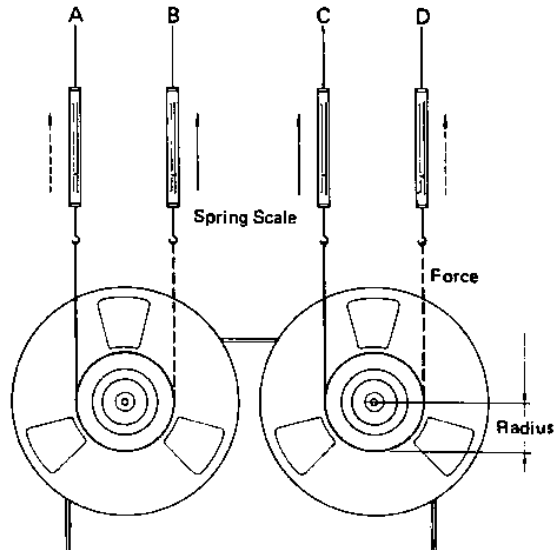

FIG. 16. BRAKE TORQUE MEASUREMENT

Forward Torque; B & C in Fig. 16	2100 - 2400 g-cm (29.2 - 33.4 oz-inch)
Reverse Torque; A & D (approx. reference values)	650 - 800 g-cm (9.0 - 11.1 oz-inch)

Torque calculating formulas:

1. Torque (in g-cm or oz-inch)
= Force or Weight (in g or oz) x Radius
(in cm or inch)
2. Conversion of g-cm to oz-inch:
g-cm x 0.0139 = oz-inch

3-4-3. Pinch roller pressure

NOTE: Pinch roller pressure is supplied by the pinch roller spring arm, and it is most important that the solenoid plunger be fully bottomed before taking any pressure measurements.

1. Hold the right tension arm up with a rubber band, string, etc.
2. Place the deck in reproduce mode, without threading tape.
3. Attach a spring scale to the pinch roller as shown in Fig. 17.
4. Pull the spring scale perpendicularly to the pinch roller arm as shown in the figure below, until the pinch roller just stops turning. The scale should then read 1.0 kg to 1.6 kg (2-3/16 lbs to 3-8/16 lbs), and there should be a clearance of approx. 0.5-1 mm at "A".
5. If necessary, loosen the adjustment screws shown in Fig. 17 and move the solenoid mounting plate until pressure and tolerance "A" are both within specifications.

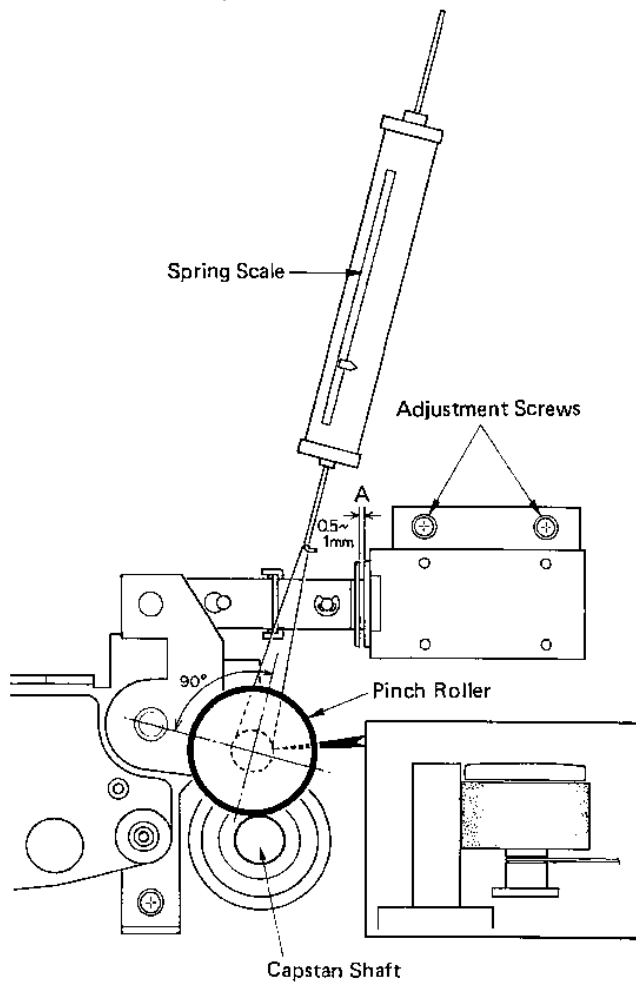

FIG. 17. PINCH ROLLER PRESSURE ADJUSTMENT

3-4-4. Tape tension servo

Tension Arm Positions and their Detection

The tape tension servo detects and controls the tape tension through either left or right tension sensor assemblies located under the front transport panel. The left and right servos function exactly the same.

The assembly includes two coils with an aluminum plate inserted between them. The aluminum plate moves as tape tension varies and, accordingly, mutual inductance between the coils varies. This causes the sensor oscillation frequency and output voltage to vary proportionately. Variation of the output voltage is used to detect the movement of the tension arm.

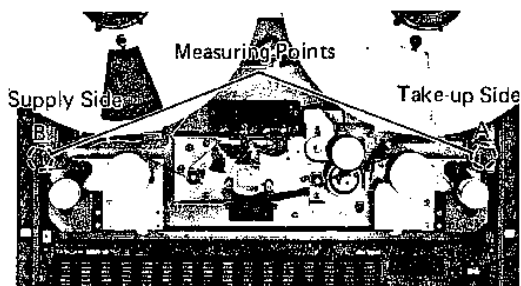

FIG. 18. TAPE TENSION MEASUREMENT POINTS

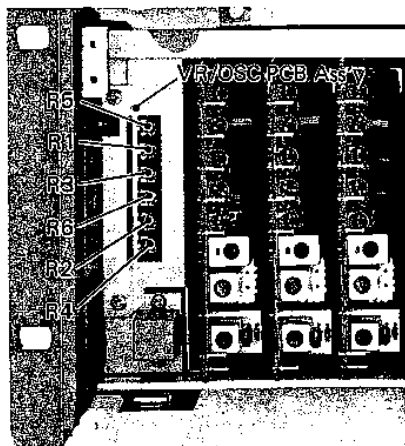

FIG. 19. TAPE TENSION ADJUSTMENT RESISTORS



FIG. 20. USING A TENTELOMETER

A. Tape Tension in Edit

1. Remove the front panel as described in 3-3-1.
2. Thread a blank tape onto the machine and wind half of the tape onto the take-up reel so that there is an equal amount of tape on both reels. Press STOP then EDIT to put the transport into Manual Edit mode.
3. Using a tension analyzer or tentelometer, measure take-up tension at test point A and back tension at test point B (Fig. 18). Both readings should be 70 ± 5 g. If not, adjust R2 (for take-up tension) and/or R1 (for back tension). Refer to Fig. 19 for locations of adjustment resistors.

B. Tape Tension in Reproduce

1. Load a blank tape and wind half of it onto the take-up reel so that there is an equal amount of tape pack on both reels.
2. Press PLAY to roll the tape in reproduce mode.
3. While the tape is rolling in reproduce mode, take a reading from a tension analyzer or tentelometer at test points A (take-up tension) and B (back tension). Both readings should be 70 ± 5 g. If either or both readings are not within the limits, adjust R4 (for take-up tension) and/or R3 (for back tension). Refer to Fig. 19 for locations of adjustment resistors.

C. Fast Winding Back Tension

1. Load a blank tape and run it to about half way so that there is an equal amount of tape pack on both reels.
2. Run the tape in F.FWD and read the tension analyzer or tentelometer at the B point shown in Fig. 18. Similarly, run the tape in REW and read the tension analyzer or tentelometer at the point A shown. Specifications (both in F.FWD and REW) are 60 ± 5 g. If necessary, adjust the following resistor(s):
R5 for F.FWD Back Tension
R6 for REW Back Tension

3-4-5. Reel table height

Reel height adjustment is required only when reel motor has been replaced or tape rubs excessively against the reel flanges.

1. Remove the front trim panel as described in paragraph 3-3-1.
2. Loosen the two set screws shown in Fig. 21.
3. Move the reel table in and out to adjust height.
4. Tighten the set screws and run tape to check the adjustment.

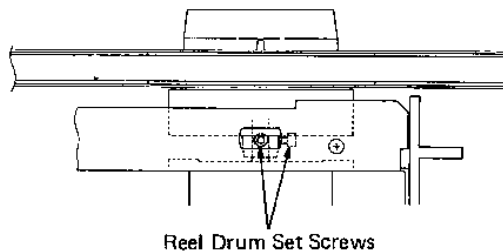

FIG. 21. REEL HEIGHT ADJUSTMENT

3-4-6. Tape speed

Tape speed is measured by using a Flutter Test Tape containing a highly accurate, continuous 3 kHz tone.

A. "FIX" Tape Speed

1. Connect a digital frequency counter to any OUTPUT, set the SPEED MODE switch on the deck to FIX.
2. Playing the beginning of the test tape, check for 3000 Hz $\pm 0.2\%$ on the frequency counter. Then fast forward the tape, stop it when its end nears, and play it back to check that the deck output is within the limits as before.
3. If limits are exceeded, check pinch roller pressure and takeup tension, and clean tape path.

B. "VARI" Tape Speed

CHECK

1. Make the following settings:
SPEED MODE switch to VARI;
PITCH CONTROL knob to center;
DISPLAY switch for "% of tape speed change" display.
2. Run the appropriate test tape in PLAY and check for 00.0 (%) in the counter display window. Then turn the PITCH CONTROL knob fully left to check that the percentage reading drops to -15 (or lower), and turn the knob fully right to check that the reading goes up to +15 (or higher). If readings don't meet specifications, proceed as follows:

ADJUSTMENT

1. Check to make sure that the deck is set as in step 1 under the previous paragraph, CHECK.
2. Open the amp panel (refer to paragraph 3-3-2).
3. Locate R5 and R6 on the DISPLAY PC Board (refer to Fig. 22) and set them to mechanical center.
4. Run the tape in PLAY and, while it plays, adjust R5 for less than 1% display, then adjust R6 for 00.0% display.

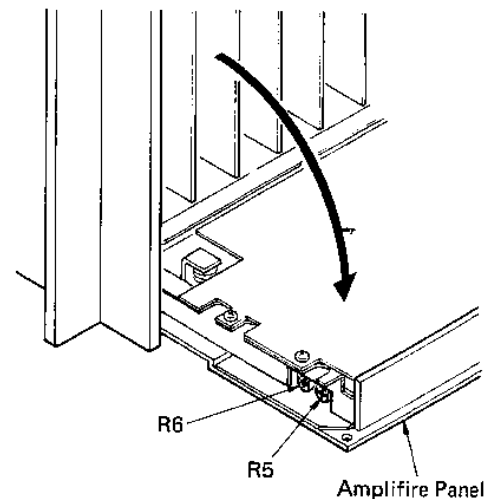

FIG. 22. "VARI" SPEED ADJUSTMENTS

3-4-7. Tape travel

After replacement or adjustment of heads, tension arm, pinch roller, capstan motor shaft or any other parts that contact tape, it is essential to check for correct tape travel.

To check tape travel, run tape in PLAY to see whether or not the tape rubs on the lower flange of the left and right tape guides. Repeat the check in F.FWD and REW also. If adjustments are necessary, proceed as follows:

1. Using a good cleaner, thoroughly clean pinch roller, capstan shaft and all other parts in the tape path.
2. Remove the left tape guide cap using a 3-mm hex wrench. Unscrew the left tension roller cap by turning it counterclockwise with your fingers.
3. Run the tape in PLAY and turn the adjustment screw located in the top center of the left tension roller in

and out so the tape's lower edge nearly touches the left tape guide lower flange (no tape curl must be observable).

4. Replace the two caps.
5. Similarly, remove the cap from both the right tape guide and right tension roller, and run the tape in Reverse Spool mode to adjust the right tension roller height.
6. Replace the caps.

After performing the above steps, be sure to check for correct height of both the left and right reel tables (paragraph 3-4-5).

NOTE: Upon completion of adjustments, be sure to check head azimuth by referring to paragraph 3-5-1.

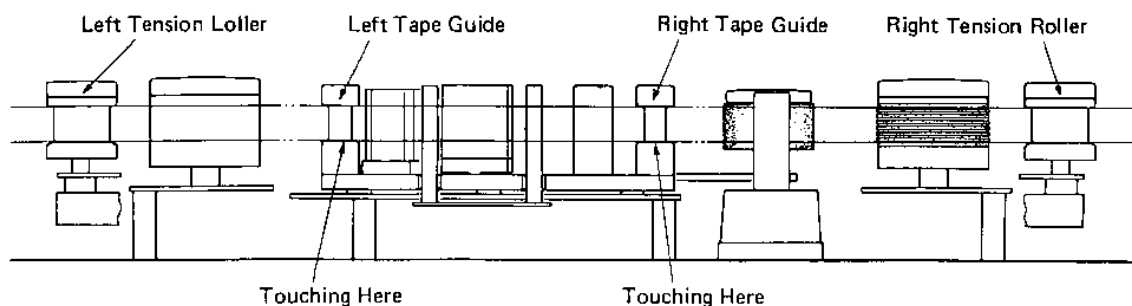

FIG. 23. TAPE POSITIONING

3-4-8. Wow and flutter (reproduce method)

1. Connect a wow and flutter meter to any channel's OUTPUT jack on the deck. Set the wow and flutter meter for "weighted" readings. Check to make sure that the meter is properly calibrated.
2. Playback the appropriate wow and flutter test tape, at normal "FIX" speed.
3. Read the wow and flutter meter. Values should be as follows:

DIN/IEC/ANSI (Peak Value, Weighted)
 HIGH Speed: $\pm 0.08\%$
 LOW Speed: $\pm 0.09\%$

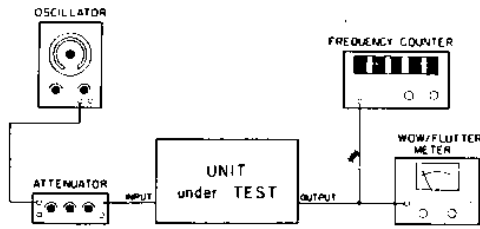

FIG. 24. WOW AND FLUTTER MEASUREMENT SET-UP

NOTE: As the measured results may vary with respect to the location on the tape at which the measurement is taken, at least two locations — the beginning and end of the tape — should be checked. There may also be a slight difference in measured absolute values, depending on the brand of meter being used.

3-4-9. Capstan servo

1. Load a blank tape, and set the TAPE SPEED selector switch to HIGH for 15 ips (38 cm/sec.) speed.
2. Locate S2 switch on the control PCB and pull out the jumper plug to reinsert it into position 2, as shown in Fig. 26.

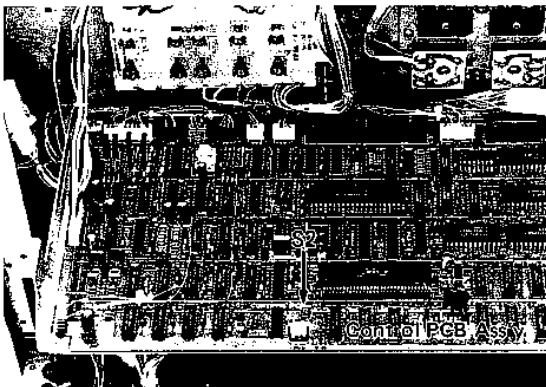

FIG. 25. SWITCH S2 LOCATION

3. Connect an oscillator to the S2's pin indicated below.

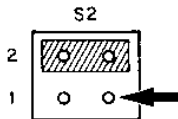

FIG. 26. OSCILLATOR CONNECTING POINT

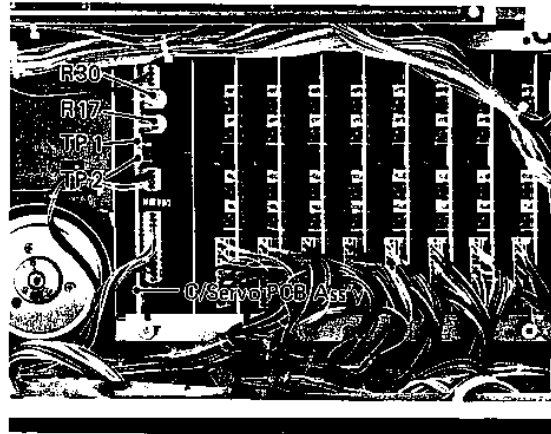

FIG. 27. CAPSTAN SERVO ADJUSTMENTS & TEST POINTS

4. Locate test point TP1 on the capstan servo PCB and connect an oscilloscope to TP1.
5. Locate R30 (5KB) on the capstan servo PCB and set that provisionally to center.
6. Run the tape in PLAY and set the oscillator so it provides a square wave signal of 1200 Hz (any voltage within 5 to 10 V).
7. Watching the scope adjust R17 (20KB) (on the capstan servo PCB) until the TP1 signal shows a duty factor of 25 % (approximate).

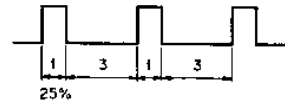

FIG. 28. R17 ADJUSTMENT

8. Change the signal frequency to 1560 Hz and adjust R30 until the duty factor of TP1 signal is 10 %
 9. Change the frequency back to the reference 1200 Hz and adjust R17 for 50 % duty factor at TP1.
 10. Change the frequency to 720 Hz then 1560 Hz, to check to see that the servo is locked. If it becomes unlocked at 720 Hz, adjust R30 (5KB) for 90 % duty factor, then recheck.
- Be sure to replace the jumper plug to its original position upon completion of adjustments.

3-5. Audio Alignment

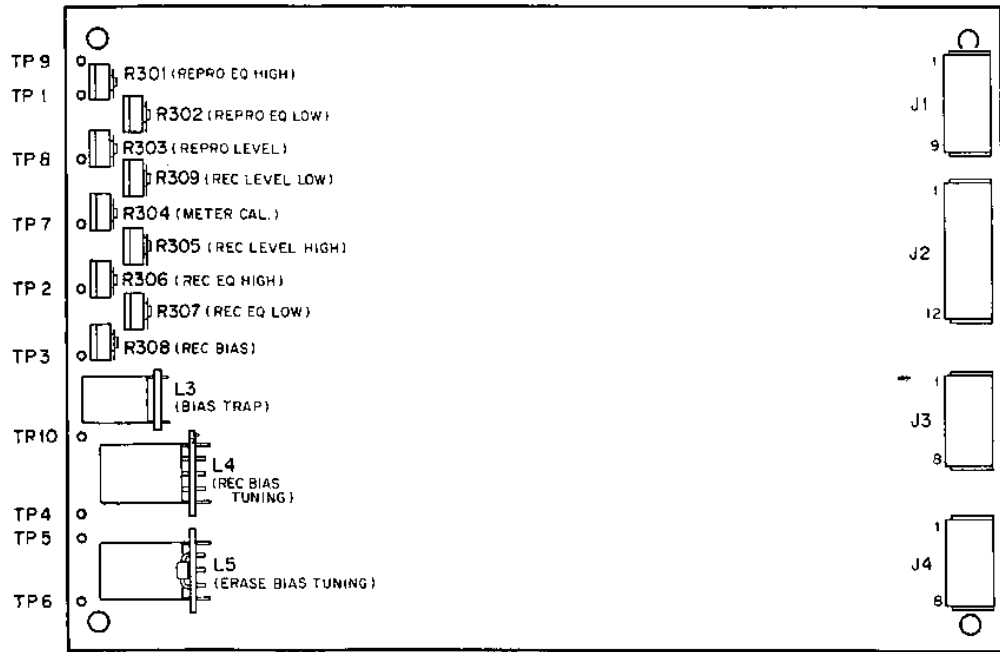

FIG. 30. LOCATIONS OF ELECTRICAL ADJUSTMENTS & TEST POINTS

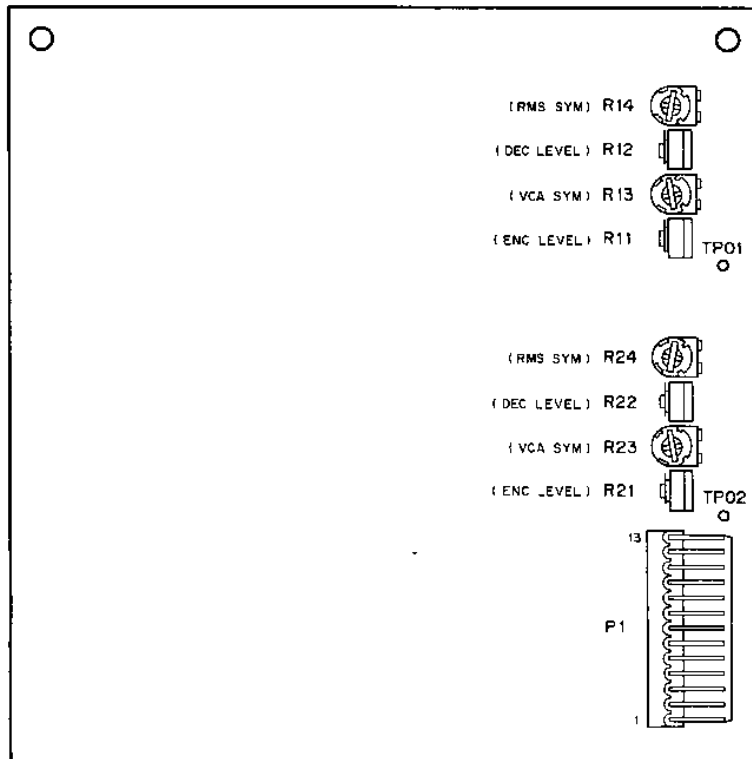

FIG. 31. DBX ADJUSTMENTS & TEST POINTS

3-5-1. Preliminary procedure (Head azimuth adjustment)

Before proceeding to audio alignment, be sure to check and adjust head azimuth as follows (only the record/repro head need be checked and adjusted; the erase head is fixed and has no adjustment):

A. CHECK

1. Make sure that tape runs at the proper height (see paragraph 3-4-7).
2. Connect the output of channel 2 to the vertical (y-axis) input terminal of an oscilloscope and the output of channel 15 to the horizontal (x-axis) input terminal of the scope. Also connect an AC voltmeter in parallel to the scope, to monitor the channels' output level.

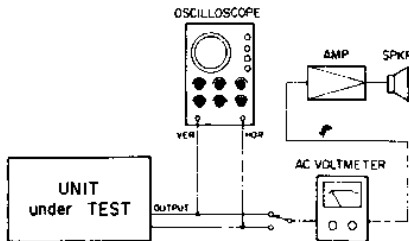

FIG. 32. HEAD AZIMUTH TEST SET-UP

3. Load the appropriate test tape (refer to page 7) and reproduce its 1 kHz and 10 kHz signals at HIGH speed, to check for less than 45° phase discrepancy between the two channel outputs as seen on the scope. Then, slowly press the running tape against the record/repro head to make sure that there is no play between the tape and head and therefore the voltmeter reading does not rise any further. If adjustment is necessary, proceed as follows:

B. ADJUSTMENT

1. Reproduce the 1 kHz and 10 kHz signals contained in the test tape as before.
2. Adjust the azimuth adjustment screws shown in Fig. 33 (by slightly loosening one while tightening the other, alternately) for less than 45° phase

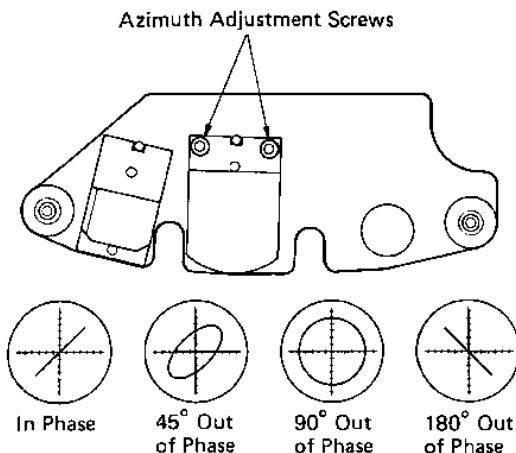

FIG. 33. HEAD AZIMUTH ADJUSTMENTS

discrepancy between the channels as seen on the scope and, at the same time, for maximum reading on the voltmeter.

3. Upon completion of adjustments, retighten the two adjustment screws, evenly. Watch the oscilloscope to be sure that the adjustment you've achieved is not undone by unevenly retightening the screws.

Once head azimuth is aligned, you are ready to move on to electronics adjustments. Observe the following:

- Perform each check (and adjustment when necessary) for channel 1 first, then repeat procedure for all the remaining channels.
- Before removing and reinstalling any PCB cards, check to make sure that power is turned off.

In the following, 0 dBV is referenced to 1 V.

3-5-2. Input level check

1. Connect test equipment to the channel 1 input and output jacks of the deck as shown in Fig. 34.
2. Set the oscillator to apply a 1 kHz, -10 dBV (316 mV), and engage ALL INPUT.
3. Check for -10 dBV (316 mV) on the AC voltmeter.
4. Repeat procedure for the remaining channels.

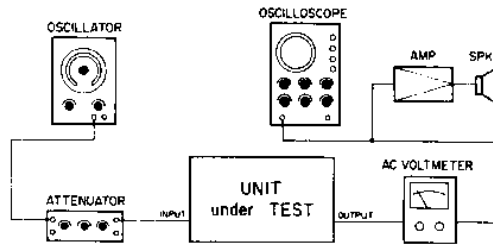

FIG. 34. SET-UP FOR LEVEL & FREQUENCY RESPONSE CHECKS

3-5-3. Meter setting (input signal reading)

1. Apply the nominal -10 dBV level to input jacks and check that the corresponding channels' LED meters read 0 dB. If not, proceed to the next step.
2. Locate R304 on the R/P AMPL PCB of channel being checked and adjust R304 until the meter reads 0 dB.

3-5-4. Reproduce level

1. If the ALL INPUT is engaged (LED on), release it (LED off).
2. Load a reproduce alignment test tape for HIGH speed use (refer to page 7) and reproduce the 1 kHz signal contained in the tape, to check for -10 dBV (316 mV) on the AC voltmeter connected to the channel 1 output jack of the deck. Also check that the LED meter on the deck reads 0 dB. If necessary, adjust R303 on the R/P AMPL PCB of the channel concerned.
3. Repeat procedure for the remaining channels.

3-5-5. Reproduce frequency response

1. Load the appropriate test tape (refer to page 7) on the deck.
2. Check to make sure that ALL INPUT is not engaged (LED off), then press PLAY.
3. Measure the output signal and check that the frequency range is within the limits shown in Fig. 35. If necessary, adjust the following pots on the R/P AMPL PCBs:
R301 for response at HIGH;
R302 for response at LOW.

If adjustments of the pots have no effect, perform the following:

- a. If specific channel or channels don't meet specifications, replace the R/P AMPL PCB of the corresponding channels.
- b. If all the channels don't meet specifications, check power supplies, head alignment, and clean and demagnetize tape path. If, for all that, every channels remain out of specs, the record/repro head must be replaced.

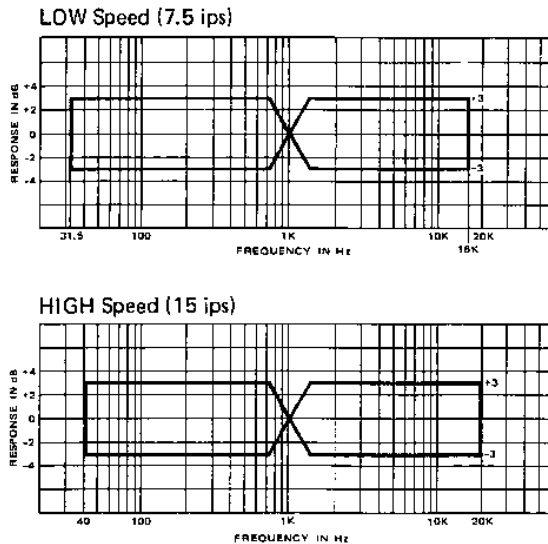

FIG. 35. REPRODUCE FREQUENCY RESPONSE

3-5-6. Bias tuning and bias trap adjustments

Generally, erase bias tuning need be adjusted only when erase head is replaced, and record bias trap only when R/P AMPL PCBs or record/repro head are replaced.

Precautions

Observe the following:

- Be sure to use a non-conductive screwdriver (i.e., wooden, plastic).
- For bias level measurements (paragraph 3-5-7), use an AC voltmeter whose input has a floating capacitance of less than 100 pF.

A. ERASE HEAD BIAS TUNING (L5)

CAUTION: Do not short-circuit between TP-6 and GND during the following procedure.

1. Connect a DC voltmeter between TP-5 (Hot) and TP-6 (Cold) on the CH 1 R/P AMPL. PCB.
2. Press the "Rec Function" switch of channel 1 then the master RECORD and PLAY buttons to initiate Record mode.
3. Use an insulated screwdriver to adjust L5 on the same amplifier PC board until the DC meter shows minimum reading.
4. Repeat the procedure for the remaining channels.

B. RECORD HEAD BIAS TUNING (L4)

CAUTION: Do not short-circuit between TP-6 and GND during the following procedure.

1. Connect a DC voltmeter between TP-4 (Hot) and TP-6 (Cold) on the CH 1 R/P AMPL. PCB.
2. Press the "Rec Function" switch of channel 1 then the master RECORD and PLAY buttons to initiate Record mode.
3. Turn R308 on the R/P AMPL. PCB fully clockwise.
4. Use an insulated screwdriver to adjust L4 on the same amplifier PC board until the DC voltmeter shows minimum reading.
5. Repeat the procedure for the remaining channels.

C. RECORD BIAS TRAP (L3)

1. Connect an AC voltmeter between TP-3 and TP-9 (GND) on the CH 1 R/P AMPL. PCB.
2. Press the channel 1 "Rec Function" switch then the master RECORD and PLAY buttons to initiate Record mode.
3. Adjust L3 on the CH 1 R/P AMPL. PCB for minimum reading on the voltmeter.
4. Repeat the procedure for the remaining channels.

3-5-7. Record bias adjustment

1. Load a blank test tape YTT-8163 on the deck.
2. Set the TAPE SPEED selector switch to LOW.
3. Connect an AC voltmeter between TP-1 and TP-9 on the R/P AMPL. PCB.
4. Initiate Record mode.
5. Adjust R308 on the R/P AMPL. PCB for a 23 mV ± 2 mV reading on the voltmeter.

3-5-8. Record level

The following procedure **MUST** be performed **AFTER** completion of the bias adjustment.

1. Set the TAPE SPEED selector switch to HIGH.
2. Connect test equipment to the tape deck as in paragraph 3-5-2.
3. Apply a 1 kHz, -10 dBV (316 mV) signal to the channel 1 INPUT jack.
4. Load a blank test tape YTT-8163 on the deck.
5. Record the 1 kHz, -10 dBV signal. Then rewind the tape and play the recording, to check for -10 dBV (316 mV) ± 0.5 dB at the OUTPUT jack. If necessary, adjust R305 on the R/P AMPL. PCB.
6. Set the TAPE SPEED selector switch to LOW and repeat procedure. If necessary adjust R309. Check and adjust all the channels in the same way. The level difference between channels should be less than 0.5 dB.

NOTE: The above check should be performed at HIGH speed *first*, and if any channel output level is adjusted, be sure, thereafter, to repeat the check (and the adjustment if necessary) at LOW speed.

3-5-9. DBX IN/OUT level

When record level is adjusted (paragraph 3-5-8), perform the following:

1. Connect a 1 kHz, -10 dBV (316 mV) signal to the INPUT jack of channel 1.
2. Record the input signal on a blank tape, first with the DBX switch (1-8) turned on, then with the DBX switch turned off.
3. Rewind the tape and play the recording, to check that the OUTPUT level from the recording made with DBX is -10 dBV ± 0.5 dB, and the level from the recording without DBX is exactly -10 dBV.
4. Similarly, check the remaining channels.

3-5-10. Overall frequency response

HIGH SPEED

1. With the same connections as in paragraph 3-5-8, change the input signal to 20 kHz, -10 dBV (316 mV) and connect this signal to channel 1 INPUT jack.
2. Making sure that the TAPE SPEED selector switch is set to HIGH, record the input signal, then rewind the tape and play the recording, to check for -10 dBV (316 mV) at the channel 1 OUTPUT jack. If necessary, adjust R306 on the R/P AMPL. PCB.
3. Initiate again record mode and sweep the signal frequency over the range of 40 Hz to 20 kHz. Then rewind the tape and play the recording. Measure the output level over the specified frequency range and check that the level falls within ± 3 dB (without DBX). (With DBX, the tolerance is ± 6 dB.) There is no adjustment.

LOW SPEED

4. Set the TAPE SPEED selector to LOW, change the input signal to 16 kHz, -20 dBV (100 mV), initiate record mode, rewind the tape, and play the recording, to check for -20 dBV at the OUTPUT jack. If necessary, adjust R307 on the R/P AMPL. PCB.
5. Initiate again record mode and sweep the signal frequency over the range of 30 Hz to 16 kHz. Then

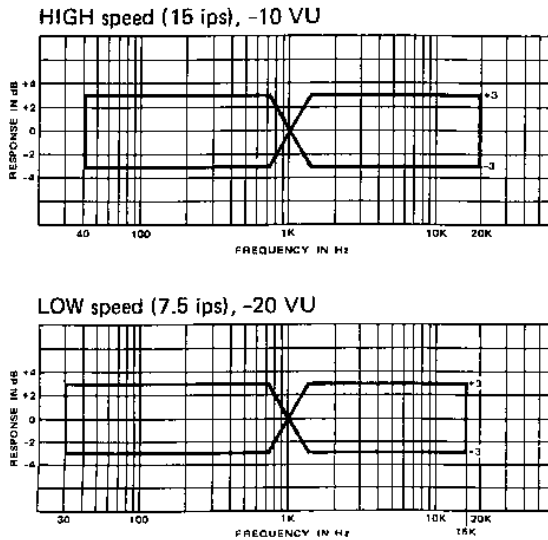

FIG. 36. OVERALL FREQUENCY RESPONSE

rewind the tape and play the recording. Measure the output level over the specified frequency range and check that the level falls within ± 3 dB (without DBX). (With DBX, the tolerance is ± 6 dB.) There is no adjustment.

6. Repeat the procedure for the remaining channels.

3-5-11. Overall signal-to-noise ratio

The following procedure necessitates connecting a 20 Hz-20 kHz band pass filter between the deck's OUTPUT jacks and AC voltmeter.

1. Record on a blank test tape a 1 kHz, -10 dBV (316 mV) signal for a while, then disconnect the input signal and initiate again record mode.
2. Stop the tape and rewind it to the beginning of the 400 Hz recording.
3. Play the tape and compare the level on the voltmeter from the 1 kHz recording with the level from the "no-signal" recording. The level difference should be 45 dB or greater (HIGH speed)/43 dB or greater (LOW speed).

If difference is below specifications, perform the following:

- a. Demagnetize heads and other metal parts in the tape path.
- b. Check Erasure (paragraph 3-5-13).
- c. Check and adjust Record Bias (paragraph 3-5-7). Then repeat the procedure above using another blank test tape.

3-5-12. Overall distortion check

1. Connect test equipment as shown in Fig. 37.
2. Set the oscillator to provide a 1 kHz, -10 dBV (0.3 V) signal, and record this signal.
3. Play back the recording to read the distortion analyzer.

Reading should be less than 1%. If values are greater than this specification, the following may fix the problem:

- Repeat the record bias adjustment procedure (paragraph 3-5-7).
- Demagnetize the erase and record/repro heads.
- As a final measure, replace the record/repro head.

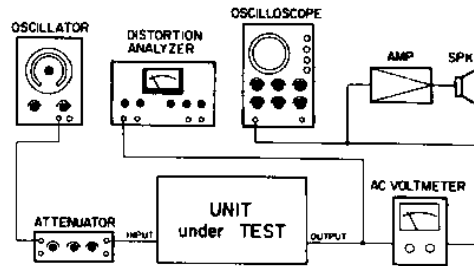

FIG. 37. DISTORTION TEST SET-UP

3-5-13. Erasure

1. Connect test equipment as shown in Fig. 38.
2. Set the oscillator to apply a 1 kHz, 0 dB (1 V) signal to the deck, record this signal, rewind the tape to the beginning of the recording, then play it back to measure the output level.
3. Rewind again the tape to the beginning of the recording, disconnect the input signal, then put the deck again into Record mode.
4. Rewind the tape to the beginning of the "no-signal" recording, and play it back to measure the output level. Compare the level from the original 1 kHz recording with the level from the "no-signal" recording. The level difference should be 70 dB or greater. If not, perform the following:
 - a. Clean tape path.
 - b. Check transport performance (section 3-4).

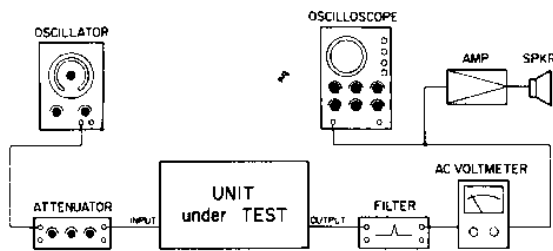

FIG. 38. ERASURE TEST SET-UP

3-5-15. Sync crosstalk

Sync crosstalk refers to the crosstalk occurred during sync recordings (overdubs) because record bias signal leaks from a channel set for record onto its surrounding channels set for playback.

Test set-up is the same as in paragraph 3-5-14.

1. Apply a 1 kHz, -10 dBV (316 mV) signal to the channel 1 INPUT jack and start recording.
2. While the recording is taking place, measure the output of channel 1 to get a reference level. Then measure the output of channel 2. The difference between the channels should be 10 dB or greater.
3. Repeat procedure to check sync crosstalk from each remaining channel onto its surrounding channels (from channel 2 in record onto channels 1 and 3 in play, from channel 3 in record onto channels 2 and 4 in play, from channel 4 in record onto channels 3 and 5 in play, and so forth).

3-5-14. Channel crosstalk

1. Connect test equipment as shown in Fig. 39.
2. Connect a 1 kHz, -10 dBV (316 mV) signal to the input connector of channel 1 and record this signal on track 1.
3. Rewind the tape to the beginning of the recording.
4. Play back the recording and first measure the output of channel 1 to get a level reference. Then measure the output of channel 2. The difference should be 48 dB or greater.
5. Repeat procedure to check crosstalk from each remaining channel onto its surrounding channels (from channel 2 onto channels 1 and 3, from channel 3 onto channels 2 and 4, from channel 4 onto channels 3 and 5, and so forth).

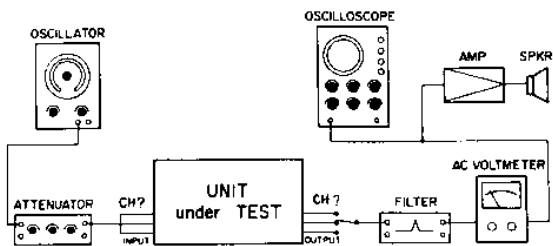

FIG. 39. CROSSTALK TEST SET-UP

3-6. DBX PCB Adjustments

The DBX PCBs have been properly adjusted before shipped and the following adjustments need be performed only when components on the PCBs are replaced because damaged.

CAUTION: Prior to removing or replacing DBX PCBs, check to make sure that the deck is turned off.

Preliminary procedure

1. Apply +12 V to J1-3 and -12 V to J1-1 on the DBX PCB (refer to Fig. 40).
2. Set all the adjustment resistors to center (Fig. 31, page 17).

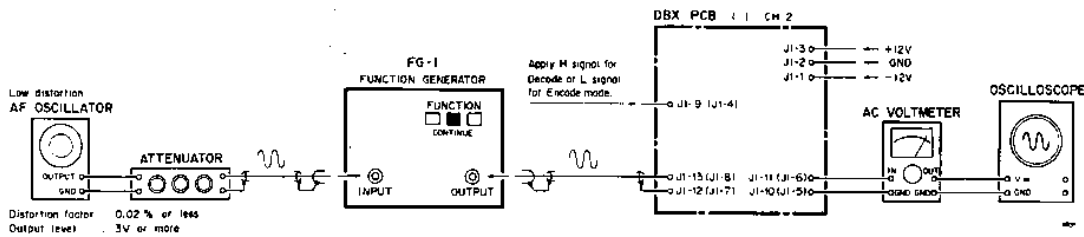

FIG. 40. RMS SYMMETRY & LEVEL ADJUSTMENTS

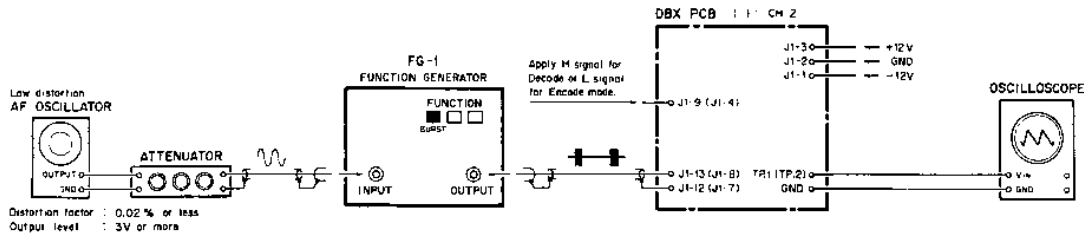

FIG. 41. RELEASE RATE ADJUSTMENT

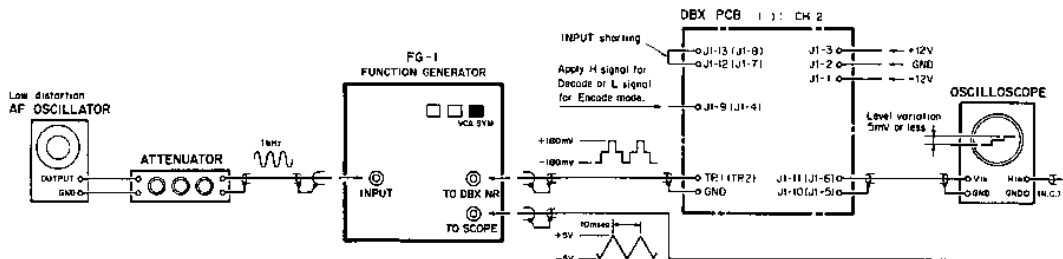
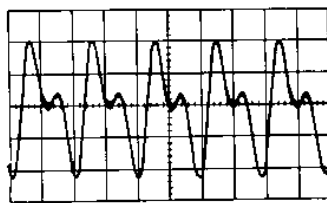
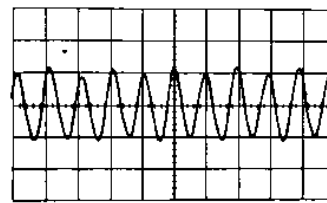

FIG. 42. VCA SYMMETRY ADJUSTMENT



Misaligned



Properly Aligned

FIG. 43. RMS SYMMETRY

3-6-1. Adjustments location

Refer to Fig. 31, page 17.

3-6-2. Decoder

Apply High signal to J1-9 (J1-4) to activate DBX Decode mode.

A. RMS Symmetry Adjustment (Connections: Fig. 40)

1. Apply a 100 Hz, 316 mV signal to J1-13 (J1-8) terminal.
2. Adjust R14 (R24) to obtain a clean 200 Hz sinewave on TP01 (TP02) (see Fig. 31).

B. VCA Symmetry Adjustment (Connections: Fig. 42)

1. Apply a staircase wave signal to TP01 (TP02), and a triangle wave signal to the horizontal input terminal on the oscilloscope.
2. Shortcircuit between J1-13 (J1-8) and J1-12 (J1-7).
3. Adjust R13 (R23) for a relatively straight horizontal line display on the oscilloscope. (Level deviation: 5 mV or less)

C. Decoding Level (Connections: Fig. 40)

1. Apply a 1 kHz, 316 mV signal to J1-13 (J1-4) terminal.
2. Adjust R12 (R22) for a 316 mV reading at J1-11 (J1-6) terminal.

D. Frequency Response (Connections: Fig. 40)

1. Vary the signal frequency to 50 Hz (316 mV) and then to 10 kHz (316 mV).
2. Read the output level at the J1-11 (J1-6) terminal for each frequency. The output level should be within the following limits with reference to level at 1 kHz.
50 Hz: +5 dB \pm 1 dB (447 mV to 602 mV)
10 kHz: +9.4 dB \pm 1 dB (793 mV to 997 mV)

E. Release Rate Check (Connections: Fig. 41)

1. Apply a 1 kHz tone burst wave signal with 8 cycles on and 128 cycles off.
2. Confirm that release rate is less than 750 mV \pm 10%.

F. Decode Effect Check (Connections: Fig. 40)

1. Apply a 1 kHz, -20 dB signal to J1-13 (J1-8) terminal.
2. Confirm that the level at J1-11 (J1-6) terminal is -30 dB \pm 0.5 dB (i.e., -20 dB against -10 dB (316 mV) reference level).
3. Apply a 1 kHz, 0 dB signal to J1-13 (J1-8) terminal.
4. Confirm that the level at J1-11 (J1-6) terminal is +10 dB \pm 0.5 dB (i.e., +20 dB against -10 dB (316 mV) reference level).

3-6-3. Encoder

Apply Low signal to J1-9 (J1-4) to activate DBX Encode mode.

A. RMS Symmetry Adjustment (Connections: Fig. 40)

1. Apply a 100 Hz, 316 mV signal to J1-13 (J1-8) terminal.
2. Check for clean 200 Hz sinewave at TP01 (TP02) (see Fig. 31).

B. VCA Symmetry Adjustment (Connections: Fig. 42)

1. Apply a staircase wave signal to TP01 (TP02), and a triangle wave signal to the horizontal input terminal on the oscilloscope.
2. Shortcircuit between J1-13 (J1-8) and J1-12 (J1-7).
3. Confirm that J1-11 (J1-6) supplies a relatively straight horizontal line on the oscilloscope (level deviation: 10 mV or less).

C. Encoding Level (Connections: Fig. 40)

1. Apply a 1 kHz, 316 mV signal to J1-13 (J1-8) terminal.
2. Adjust R11 (R21) for a -10 dB reading at J1-11 (J1-6) terminal.

D. Frequency Response (Connections: Fig. 40)

1. Vary the signal frequency to 50 Hz (316 mV) and then to 10 kHz (316 mV).
2. Read the output level at the J1-11 (J1-6) terminal for each frequency. The output level should be within the following limits with reference to level at 1 kHz.
50 Hz: -2.5 dB \pm 1 dB (213 mV to 240 mV)
10 kHz: -4.8 dB \pm 1 dB (166 mV to 186 mV)

E. Release Rate Check (Connections: Fig. 41)

1. Apply a 1 kHz tone burst wave signal with 8 cycles on and 128 cycles off.
2. Confirm that release rate is less than 750 mV \pm 10%.

F. Encode Effect Check (Connections: Fig. 40)

1. Apply a 1 kHz, -70 dB signal to J1-13 (J1-8) terminal.
2. Confirm that the level at J1-11 (J1-6) terminal is -40 dB \pm 0.5 dB (i.e., -30 dB against -10 dB (316 mV) reference level).
3. Apply a 1 kHz, +10 dB signal to J1-13 (J1-8) terminal.
4. Confirm that the level at J1-11 (J1-6) terminal is 0 dB \pm 1 dB (i.e., +10 dB against -10 dB reference level).

CHECKS AND ADJUSTMENTS CHART

ADJUST STEP	WHAT IS IT CALLED	SIGNAL SOURCE AND AMOUNT	WHAT TEST GEAR TO USE	WHAT IS THE RECORDER DOING	POINT TO ADJUST	WHAT READING TO ADJUST FOR
1	Input Level	1 kHz signal at -10 dBV from oscillator connected to INPUT jack	VTVM connected to OUTPUT jack	Stop mode with ALL INPUT engaged.	Check only	-10 dBV (316 mV) on VTVM
2	Meter (Input)	Same as above	LED meter	Same as above	R304	0 dB on LED meters.
3	Reproduce Head Alignment	16 kHz, nominal level signal contained in test tape for HIGH speed use. See p. 7, "Test Equipment".	VTVM and oscilloscope with vertical and horizontal inputs connected to OUTPUT CH2 and 15.	Reproduce at HIGH speed with ALL INPUT disengaged.	Repro head azimuth adjusting screw.	Maximum output, less than 45° out of phase of Trk 2 & 15 outputs (at 10 kHz).
4	Reproduce Level	Nominal level signal contained in test tape (p. 7)	VTVM connected to OUTPUT jack.	Reproduce at High speed with ALL INPUT disengaged.	R303	-10 dBV (316 mV) on VTVM.
5	Reproduce EQ (High frequency) at High speed.	20 kHz signal contained in test tape (p. 7)	VTVM connected to OUTPUT jack.	Reproduce at High speed with ALL INPUT disengaged.	R301	Same reading on VTVM as for 1 kHz signal.
6	Reproduce EQ (High frequency) at Low speed.	16 kHz signal contained in test tape.	Same as above	Reproduce at Low with ALL INPUT disengaged.	R302	Same as above
7	Bias Trap Adjustment	No input signal	VTVM connected to Bias Trap test points TP-3 and TP-9.	Recording with no signal connected.	L3	Minimum output at Bias Trap test point.
8	Bias Level Adjustment	No input signal	VTVM connected between TP-1 & TP-9.	Record at LOW onto the same type of tape as used for the actual recording.	R308	23 mV ± 2 mV on VTVM
9	Recording Level at High speed	1 kHz signal at -10 dBV connected to INPUT jack.	VTVM connected to OUTPUT jack.	Recording at HIGH then its playback.	R305	-10 dBV (316 mV) at OUTPUT jack.
10	Recording Level at Low speed	Same as above	Same as above	Recording at LOW then its playback.	R309	Same as above
11	Overall Frequency at High speed. (HIGH-FREQ)	20 kHz signal connected to INPUT jack (at -10 dBV).	Same as above	Same as above	R306	Within the limits given in Fig. 36.
12	Overall Frequency at Low speed. (HIGH-FREQ)	16 kHz signal connected to INPUT jack (at -20 dBV).	Same as above	Same as above	R307	Same as above
13	Overall Signal-to-Noise Ratio	No input signal	VTVM connected to OUTPUT jacks.	Recording at HIGH then at LOW, with ALL INPUT disengaged.		Check for 45 dB or better (for HIGH speed)/43 dB or better (for LOW speed)
14	Erasure	1 kHz signal, 0 dBV connected to INPUT jack. Apply signal for short time only.	VTVM and 1 kHz band pass filter connected to OUTPUT.	1 kHz recording then no-signal recording through the 1 kHz recorded section. Playback to measure the level difference.		70 dB or greater (through 1 kHz filter). (Refer to paragraph 3-5-13.)
15	DBX Adjustment DECODER	Same as step 4	Same as step 4	dBx IN and OUT.	R12 (R22) on the DBX PCB	-10 dBV (316 mV) on VTVM
16	DBX Adjustment ENCODER	Same as step 9	Same as step 9	Same as above	R11 (R21) on the DBX PCB	Same as above

4. PARTS LISTS

4-1. Mechanics

Exploded View-1

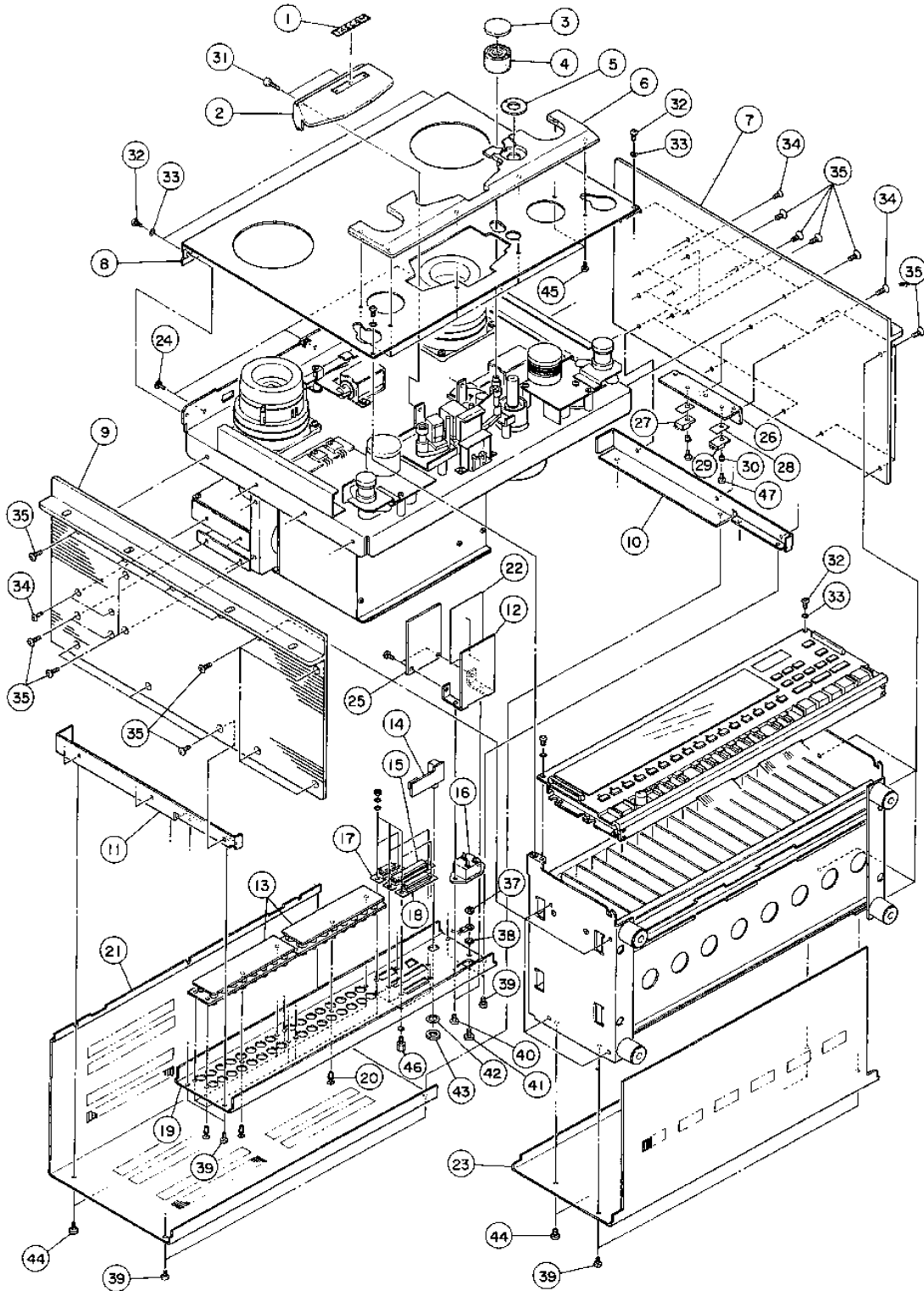

EXPLODED VIEW-1

REF. NO.	PARTS NO.	DESCRIPTION	REMARKS
1- 1	*5720201400	TASCAM BADGE	
1- 2	*5801132100	HOUSING, HEAD	
1- 3	*5801144400	CAP, PINCH ROLLER	
1- 4	*5800291500	PINCH ROLLER, 1/2 INCH	
1- 5	*5801144200	RING(A), COSMETIC	
1- 6	*5801132300	BASE, HOUSING	
1- 7	*5801175700	PANEL(R), SIDE	
1- 8	*5801141200	PANEL, FRONT	
1- 9	*5801143800	PANEL(L), SIDE	
1-10	*5801168700	ANGLE(R) ASSY, REAR	
1-11	*5801168800	ANGLE(L) ASSY, REAR	
1-12	*5801159600	BRACKET, INLET	
1-13	*5200259400	IN/OUT PCB ASSY	
1-14	*5200258600	BAUD RATE PCB ASSY	
1-15	*5334055800	SOCKET, CONN. 37S D-SUB	
1-16	*5332019500	AC SOCKET, 3P	
1-17	*5334056000	SOCKET, CONN. 15S D-SUB	
1-18	*5334055900	SOCKET, CONN. 25S D-SUB	
1-19	*5801140900	PANEL, CONNECTOR	
1-20	*5534878000	RIVET, PUSH B	
1-21	*5801141700	COVER, TOP	
1-22	*5801169600	SHEET, INLET BRACKET	
1-23	*5801140400	COVER, BOTTOM	
1-24	*5800501800	SCREW, SHOULDER H	
1-25	*5200263600	FILTER PCB ASSY	
1-26	*5801143300	HEATSINK(B)	
1-27	*5145087000	TR., 2SD-313E	
1-28	*5033291000	PLATE, INSULATOR	
1-29	*5145129000	TR., 2SB-507E	
1-30	*5033295000	TUBE, INSULATOR	
1-31	*5781773010	SCREW, HEXAGON M3X10	
1-32	*5781783006	SCREW, PHA3X6FNB	
1-33	*5785223000	WASHER, FIBER 3X6X0.5T (BLK)	
1-34	*5780323010	SCREW, FLAT COUNTERSUNK M3X10 (BLK NI)	
1-35	*5780324010	SCREW, FLAT COUTRESUNK M4X10 (BLK NI)	
1-36	*Vacant		
1-37	*5781814000	NUT M4	
1-38	*5785124000	WASHER, ROCK 4.0MM	
1-39	*5783593006	SCREW, C-TITE M3X6	
1-40	*5780023008	SCREW, BIND M3X8 (BLK NI)	
1-41	*5780024008	SCREW, BIND M4X8 (BLK NI)	
1-42	*5730029600	WASHER(9MM FOR VR)	
1-43	*5730029700	NUT(9MM FOR VR)	
1-44	*5780024006	SCREW, BIND M4X6 (BLK NI)	
1-45	*5781002606	SCREW, PAN; TAP M2.6X6	
1-46	*5730015900	POST, JACK D20418-J3F	
1-47	*5780103006	SCREW, PAN M3X6	

Parts marked with *require longer delivery time.

Exploded View-2

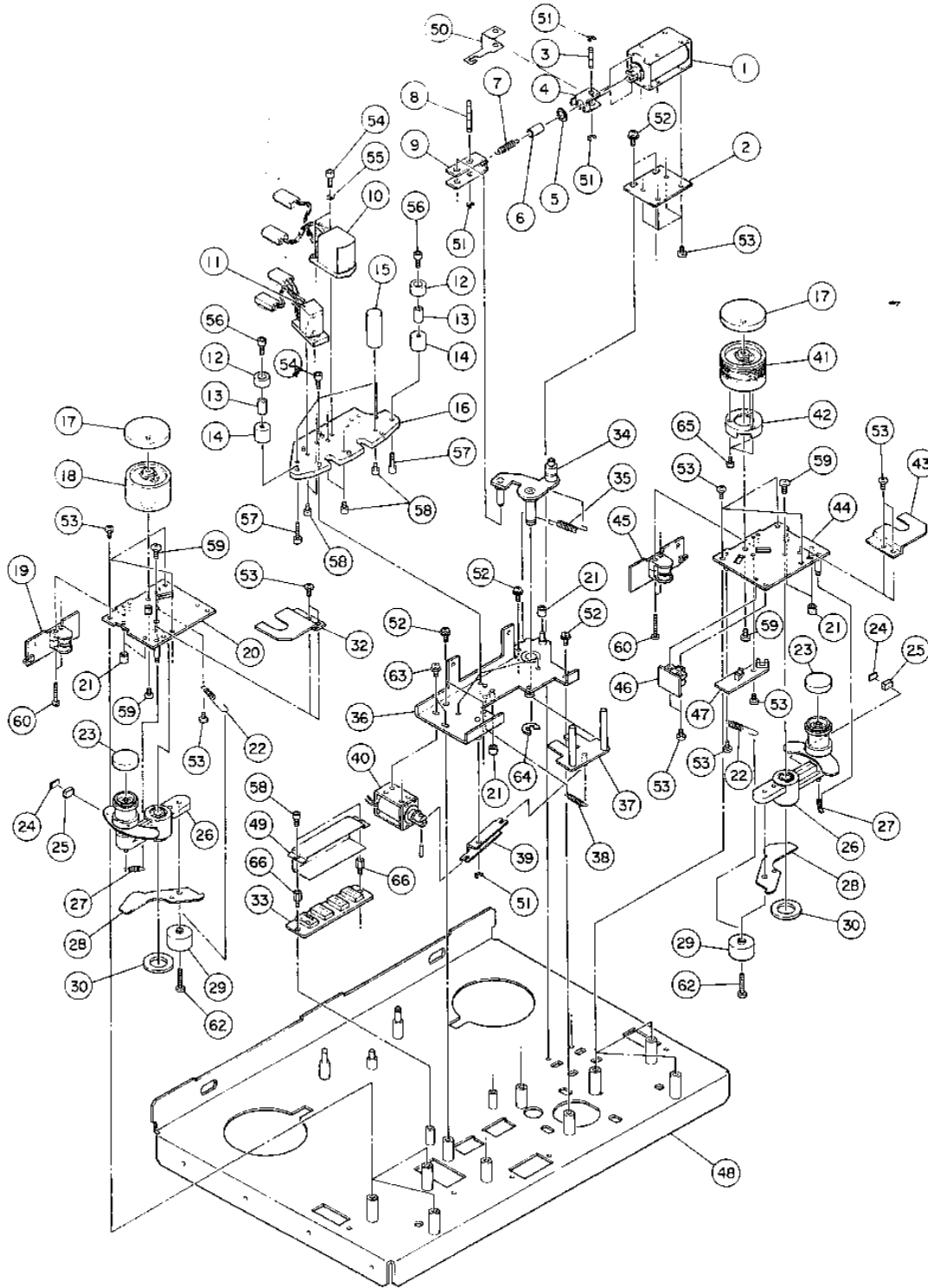

EXPLODED VIEW-2

REF.NO.	PARTS NO.	DESCRIPTION	REMARKS
2- 1	5313004000	SOLENOID, PINCH ROLLER	
2- 2	*5801137100	BRACKET, SOLENOID	
2- 3	*5801136800	SHAFT(A), JOINT	
2- 4	*5801136600	LINK(A)	
2- 5	*5801137000	CUSHION	
2- 6	*5785606020	SPACER, 6.2X7.8X20	
2- 7	*5801137200	SPRING, PINCH ROLLER	
2- 8	*5801136900	SHAFT(B), JOINT	
2- 9	*5801136700	LINK(B)	
2-10	5378308000	HEAD, R/P	
2-11	5378308100	HEAD, ERASE	
2-12	5801134000	CAP, GUIDE	
2-13	5801134200	GUIDE, TAPE	
2-14	*5801134100	BASE, GUIDE	
2-15	*5801134300	POLE, DUMMY	
2-16	*5801133700	BASE ASSY, HEAD	
2-17	5801138700	CAP, ROLLER	
2-18	5801130600	ROLLER ASSY	
2-19	*5200258400	SENSOR PCB L ASSY	Refer to pages 47 & 53
2-20	*5801137500	BASE ASSY(L), TENSION	
2-21	*5800496100	STOPER	
2-22	*5801146500	SPRING, SERVO	
2-23	5801138600	CAP, TENSION ROLLER	
2-24	*5800298500	PLATE, DAMPER	
2-25	5800298400	DAMPER	
2-26	5801129201	ARM ASSY, TENSION	
2-27	*5524106000	SPRING, FOOK PLATE	
2-28	*5801138300	PLATE, SERVO	
2-29	*5801138200	WEIGHT, COUNTER	
2-30	*5534715000	MAGNATE, THRUST	
2-31	Vacant		
2-32	*5801138400	MASK(A)	
2-33	*5200258800	HEAD PCB ASSY	Refer to pages 47 & 52
2-34	*5801136100	ARM ASSY, PINCH ROLLER	
2-35	*5801146600	SPRING, RETURN	
2-36	*5801135000	SUB CHASSIS ASSY	
2-37	*5801135700	BASE ASSY, LIFTER	
2-38	*5801146800	SPRING, RETURN	
2-39	*5801137300	PLATE, LIFTER ACTUATING	
2-40	5313004100	SOLENOID, LIFTER	
2-41	5801130100	ROLLER ASSY, COUNTER	
2-42	*5801130800	ENCODER	
2-43	*5801138500	MASK(B)	
2-44	*5801137600	BASE ASSY(R), TENSION	
2-45	*5200259900	SENSOR PCB R ASSY	Refer to pages 47 & 53
2-46	*5200258500	SHUT PCB ASSY	Refer to pages 47 & 53
2-47	*5200258300	PG PCB ASSY	Refer to pages 47 & 53
2-48		CHASSIS ASSY, MAIN	
2-49	*5801170400	PLATE, SHIELD	
2-50	*5801177300	LIMITER	
2-51	*5786003000	E-RING, E-3	
2-52	*5780143008	SCREW, PAN SEMS-B M3X8	
2-53	*5780103006	SCREW, PAN M3X6	
2-54	*5781773010	SCREW, HEXAGON M3X10	
2-55	*5785003000	WASHER, FLAT 0.5T	

(Continued on page 34)

Parts marked with *require longer delivery time.

Exploded View-3

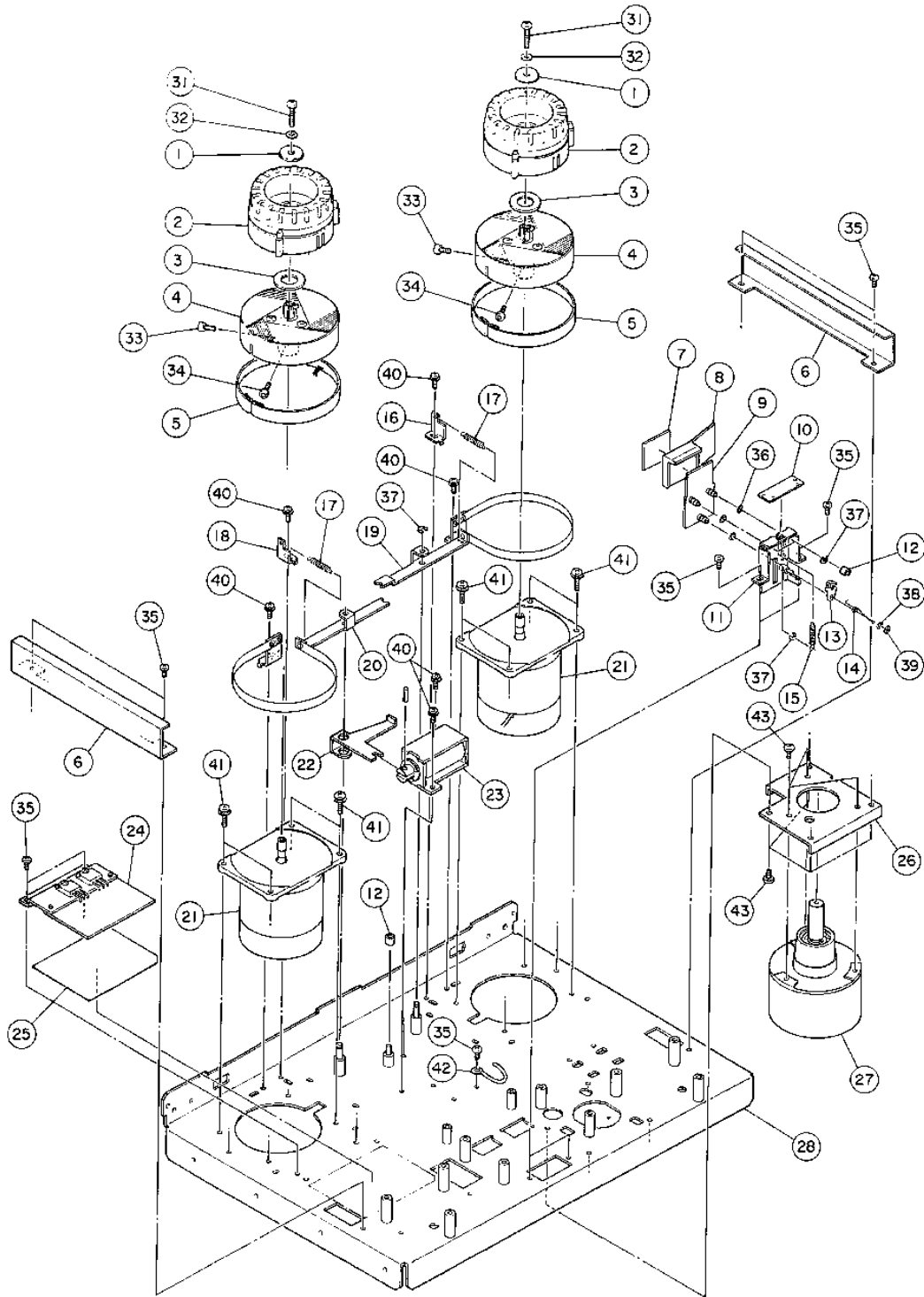

EXPLODED VIEW-3

REF. NO.	PARTS NO.	DESCRIPTION	REMARKS
3- 1	5800324901	WASHER, A	
3- 2	5740003400	CRAMPER, REEL; D 1/2 INCH	
3- 3	5800326600	SPACER, REEL	
3- 4	5801133400	TABLE ASSY, REEL	
3- 5	*5800295700	FELT, BRAKE	
3- 6	*5801146100	SUPPORT, PANEL	
3- 7	*5801144300	PLATE, SHIELD	
3- 8	*5801131800	SHIELD, HEAD	
3- 9	*5801134400	SLIDER ASSY	
3-10	*5801144000	COVER, SHIELD	
3-11	*5801134700	BASE ASSY, SHIELD	
3-12	*5800496100	STOPPER	
3-13	*5084643200	PLATE, LOCK	
3-14	*5801146700	SPRING, LOCK PLATE	
3-15	*5801146800	SPRING, RETURN	
3-16	*5801133300	HOOK (R), SPRING	
3-17	*5800301700	SPRING, BRAKE (B)	
3-18	*5801133200	HOOK (L), SPRING	
3-19	5801132900	BRAKE ASSY (R)	
3-20	5801132800	BRAKE ASSY (L)	
3-21	5370008400	MOTOR, REEL DC	
3-22	*5800299001	LEVER, BRAKE ACTUATING	
3-23	5313003900	SOLENOID, BRAKE	
3-24	*5200258200	JOINT PCB ASSY	
3-25	*5801144500	SHEET (A), INSULATOR	Refer to pages 46 & 52
3-26	*5801142400	BRACKET, MOTOR	
3-27	5370008500	MOTOR, CAPSTAN DC	
3-28		CHASSIS ASSY, MAIN	
3-31	*5780005025	SCREW, BIND M5X25	
3-32	5785225000	WASHER, FIBER (BLK) 5X10X0.5T	
3-33	*5800678500	SCREW, BALL POINT	
3-34	*5781704008	SCREW, HEXAGON M4X8 (NI)	
3-35	*5780103006	SCREW, PAN M3X6	
3-36	*5785304100	WASHER, POLIS. 4X6.5X0.25T	
3-37	*5786011500	E-RING, E-3	
3-38	*5785012300	WASHER, FLAT M2.3(0.5T)	
3-39	*5786102400	CS-RING 2.4T	
3-40	*5780143008	SCREW, PAN SEMS-B M3X8	
3-41	*5780144010	SCREW, PAN SEMS-B M4X10	
3-42	*5786713000	CLIP, HARNESS 3X9.1X50	
3-43	*5780104008	SCREW, PAN M4X8	

Parts marked with *require longer delivery time

Exploded View-4

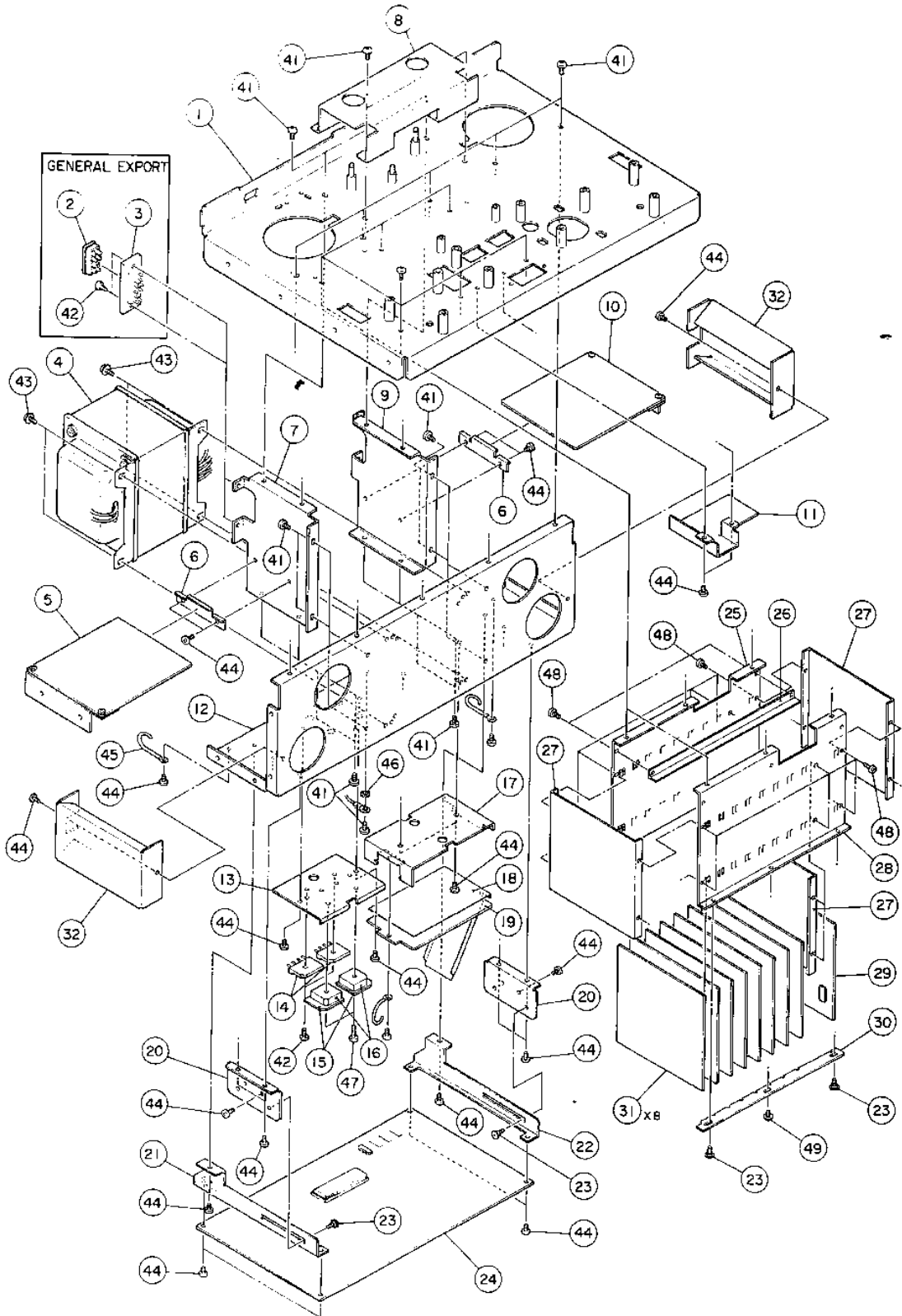

EXPLODED VIEW-4

REF. NO.	PARTS NO.	DESCRIPTION	REMARKS
4- 1		CHASSIS ASSY, MAIN	
4- 2	△ 5133014000	PLUG, VOLTAGE SELECT [GE]	
4- 3	△ 5133015001	SOCKET, VOLTAGE SELECTOR [GE]	
4- 4	△ 5320051101	TRANSFORMER, POWER [J]	
	△ 5320051201	TRANSFORMER, POWER [US, C]	
	△ 5320051300	TRANSFORMER, POWER [GE]	
	△ 5320051400	TRANSFORMER, POWER [E, UK]	
4- 5	*5200259100	P/SUPPLY PCB B ASSY	Refer to pages 43 & 51
4- 6	*5801142200	HOLDER, PCB	
4- 7	*5801144800	PLATE(L), REINFORCEMENT	
4- 8	*5801160200	PLATE(A), REINFORCEMENT	
4- 9	*5801144900	PLATE(R), REINFORCEMENT	
4-10	*5200259001	P/SUPPLY PCB A ASSY	Refer to pages 43 & 50
4-11	*5801142700	COVER, HEAD CORD	
4-12		CHASSIS, POWER SUPPLY	
4-13	*5801143100	BRACKET, DIODE	
4-14	△ 5228010000	SILICON STACK, D5SB20	
4-15	*5210259700	DIODE PCB	
4-16	△ 5228013900	SILICON STACK, 10D4B41	
4-17	*5801142500	BRACKET, FUSE PCB	
4-18	*5801144600	MASK, FUSE	
4-19	*5200259300	FUSE PCB ASSY [J, US, C, GE]	Refer to pages 45 & 52
	*5200259310	FUSE PCB ASSY [E, UK]	Refer to pages 45 & 52
4-20	*5801143000	HOLDER, BRACKET	
4-21	*5801142800	BRACKET(L)	
4-22	*5801142900	BRACKET(R)	
4-23	*5581055000	ROD, D	
4-24	*5200257902	CONTROL PCB ASSY	Refer to pages 37 & 48
4-25	*5801143400	CHASSIS(U), DBX	
4-26	*5801143600	STOPPER B	
4-27	*5801142300	FRAME, DBX	
4-28	*5801143500	CHASSIS(L), DBX	
4-29	*5200258101	C/SERVO PCB ASSY	Refer to pages 44 & 51
4-30	*5801144100	STOPPER A	
4-31	*5200259500	DBX PCB ASSY	Refer to pages 42 & 50
4-32	*5801160300	PLATE(B), REINFORCEMENT	
4-41	*5780104008	SCREW, PAN M4X8	
4-42	*5780103008	SCREW, PAN M3X8	
4-43	*5780144010	SCREW, PAN SEMS-B M4X10	
4-44	*5780103006	SCREW, PAN M3X6	
4-45	*5786713000	CLIP, HARNESS 3X9.1X50	
4-46	*5785124000	WASHER, ROCK 4.0MM	
4-47	*5780103012	SCREW, PAN M3X12	
4-48	*5783003006	SCREW, PAN S-TITE M3X6	
4-49	*5780143006	SCREW, PAN SEMS-B M3X6	

[US]:U.S.A. [E]:EUROPE [UK]:U.K. [C]:CANADA [J]:JAPAN
[GE]:GENERAL EXPORT

Parts marked with *require longer delivery time.

Exploded View-5

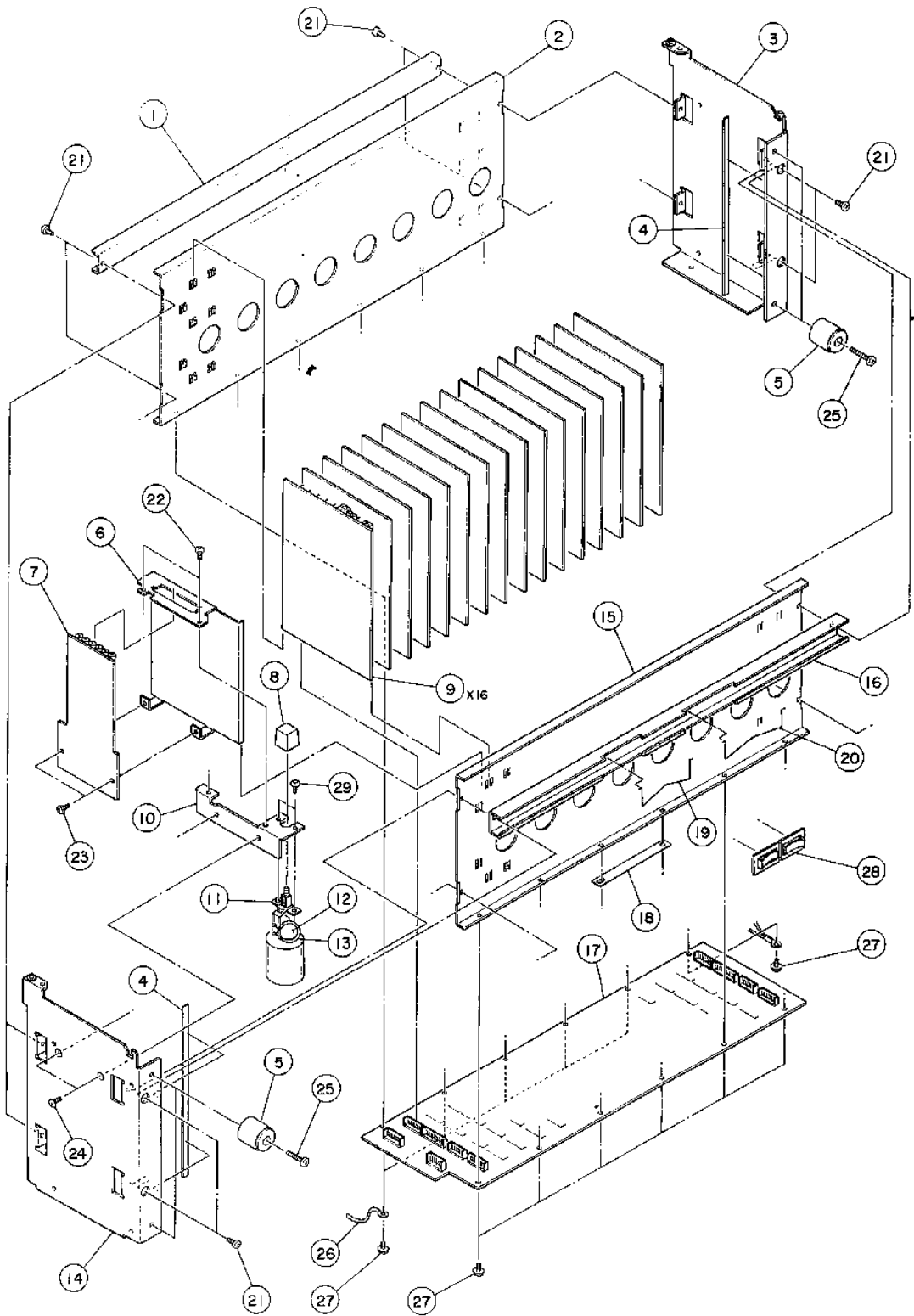

EXPLODED VIEW-5

REF. NO.	PARTS NO.	DESCRIPTION	REMARKS
5- 1	*5801140100	RIB(A), REINFORCEMENT	
5- 2	*5801141000	CHASSIS(U), AMPLIFIER	
5- 3	*5801140800	FRAME(R), SIDE	
5- 4	*5800506101	PROTECTOR, PCB	
5- 5	*5800307100	COLLAR, FOOT A	
5- 6	*5801140200	PANEL, SUB	
5- 7	*5200259200	VR/OSC PCB ASSY	Refer to pages 46 & 52
5- 8	5800173100	BUTTON, POWER	
5- 9	*5200292110	R/P AMPL PCB ASSY	Refer to pages 41 & 49
5-10	*5801139800	BRACKET, POWER SW	
5-11	△ 5300040100	SW., POWER TV-5	
5-12	△ 5267703800	SPARK KILLER 4700PF 400V M	
5-13	*5730007500	COVER, CAPASITOR SB-1417	
5-14	*5801140700	FRAME(L), SIDE	
5-15	*5801141100	CHASSIS(L), AMPLIFIER	
5-16	*5801140300	RIB(A), REINFORCEMENT	
5-17	*5200258700	MOTHER PCB ASSY	Refer to pages 39 & 49
5-18	*5801159500	PLATE, CABLE PRESSURE	
5-19	*5801159100	SPRING(A), CODE	
5-20	*5801159200	SPRING(B), CODE	
5-21	*5780003006	SCREW, BIND M3X6	
5-22	*5780103006	SCREW, PAN M3X6	
5-23	*5781003006	SCREW, PAN; TAP M3X6	
5-24	*5780202606	SCREW, FLAT M2.6X6	
5-25	*5780024020	SCREW, BIND M4X20 (BLK N1)	
5-26	*5786713000	CLIP, HARNESS 3X9.1X50	
5-27	*5780003006	SCREW, BIND M3X6	
5-28	*5730030700	CLIP, CODE A-1T	
5-29	*5781783006	SCREW, PHA3X6FNB	

(Continued from page 28)

EXPLODED VIEW-2

REF NO	PARTS NO:	DESCRIPTION	REMARKS
2-56	*5781773008	SCREW, HEXAGON M3X8	
2-57	*5781773020	SCREW, HEX M3X20	
2-58	*5781773006	SCREW, HEXAGON M3X6	
2-59	*5780104008	SCREW, PAN M4X8	
2-60	*5780102020	SCREW, PAN M2X20	
2-61	Vacant		
2-62	*5780103020	SCREW, PAN M3X20	
2-63	*5780143006	SCREW, PAN SEMS-B M3X6	
2-64	*5786007000	E-RING, E-7	
2-65	*5780002005	SCREW, BIND M2X5	
2-66	*5801170300	SPACER	

Parts marked with *require longer delivery time.

Exploded View-6

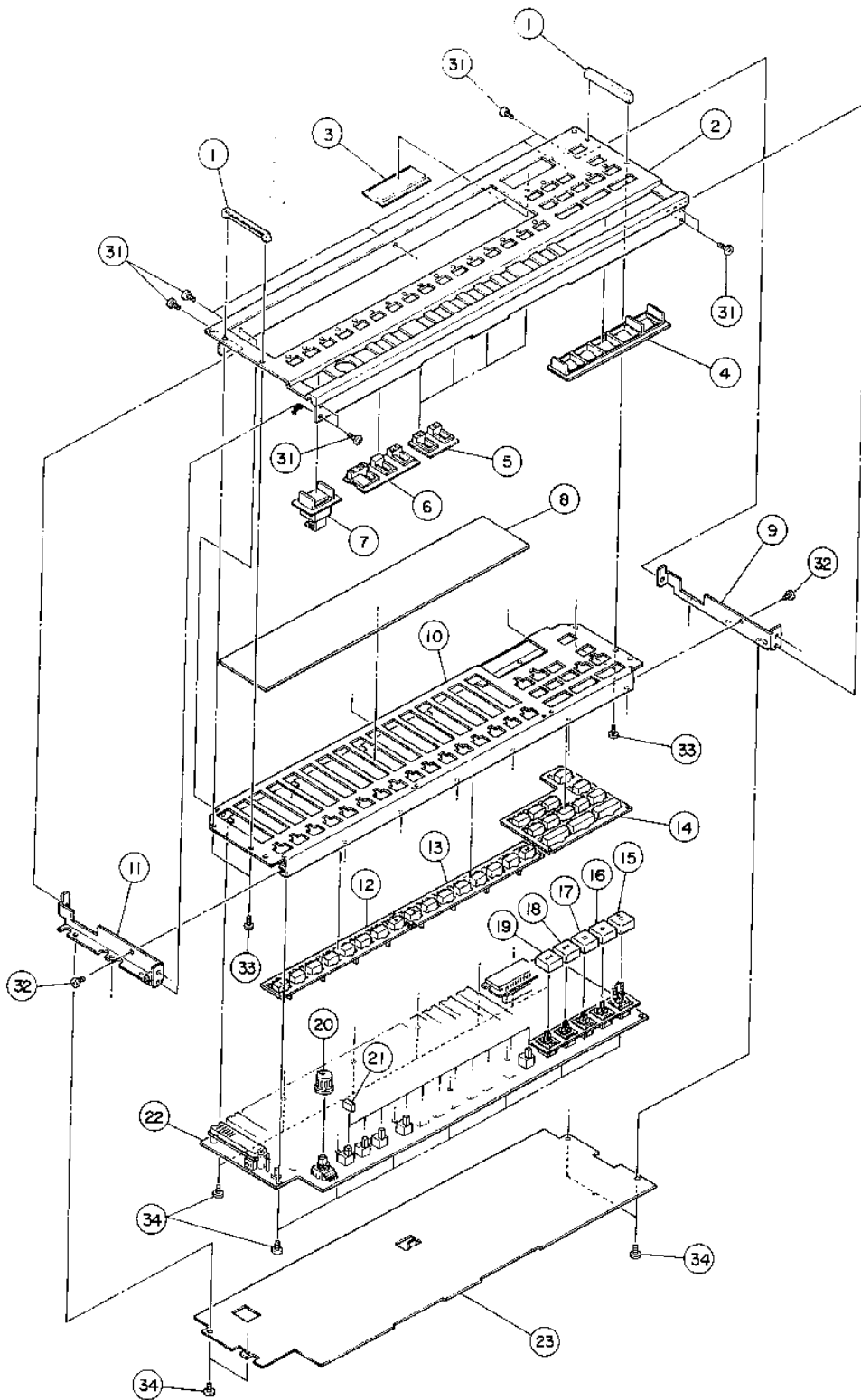

EXPLODED VIEW-6

REF.NO.	PARTS NO.	DESCRIPTION	REMARKS
6- 1	*5801139200	HANDLE P-N15-A	
6- 2	*5801128600	PANEL, OPERATION	
6- 3	*5801128700	LENZ, COUNTER	
6- 4	*5801131400	ESCUTCHEON, OPERATION BUTTON	
6- 5	*5801131600	ESCUTCHEON B	
6- 6	*5801131500	ESCUTCHEON A	
6- 7	5801139900	BUTTON ASSY, POWER	
6- 8	*5801128900	COVER, METER	
6- 9	*5801139400	ANGLE ASSY(R), SIDE	
6-10	*5801140500	SUB PANEL, AMP.	
6-11	*5801139300	ANGLE ASSY(L), SIDE	
6-12	5801141400	BUTTON, FUNCTION;1-8	
6-13	5801141500	BUTTON, FUNCTION;9-16	
6-14	5801132201	BUTTON, CONTROL	
6-15	5801131300	BUTTON(REC)	
6-16	5801131100	BUTTON(PLAY)	
6-17	5801131200	BUTTON(STOP)	
6-18	5801130900	BUTTON(FF)	
6-19	5801131000	BUTTON(REW)	
6-20	5801131900	KNOB, PITCH CONTROL	
6-21	5801128800	BUTTON	
6-22	*5200258002	OPERATION PCB ASSY	
6-23	*5801140600	COVER, OPERATION PCB	Refer to pages 39 & 49
6-31	*5780123006	SCREW, PAN M3X6 (BLK N1)	
6-32	*5780103006	SCREW, PAN M3X6	
6-33	*5781002608	SCREW, PAN; TAP M2.6X8	
6-34	*5783003006	SCREW, PAN S-TITE M3X6	

INCLUDED ACCESSORIES

REF.NO.	PARTS NO.	DESCRIPTION	REMARKS
	△ 5350015100	AC CORD [J,GE]	
	△ 5350008000	AC CORD [US,C]	
	△ 5350017200	AC CORD [E]	
	△ 5128057000	AC CORD [UK]	
	*5200259800	EXTENTION PCB ASSY	
	*5800307100	COLLAR, FOOT A	
	*5780024020	SCREW, BIND M4X20 (BLK N1)	
	*5534580000	BELT, MINI C [EXCEPT J]	
	*5801011300	PULLER, CARD	
	*5700107000	OWNER'S MANUAL [J]	
	*5700107100	OWNER'S MANUAL [EXCEPT J]	
[US]:U.S.A. [E]:EUROPE [UK]:U.K. [C]:CANADA [J]:JAPAN [GE]:GENERAL EXPORT			
Parts marked with *require longer delivery time.			

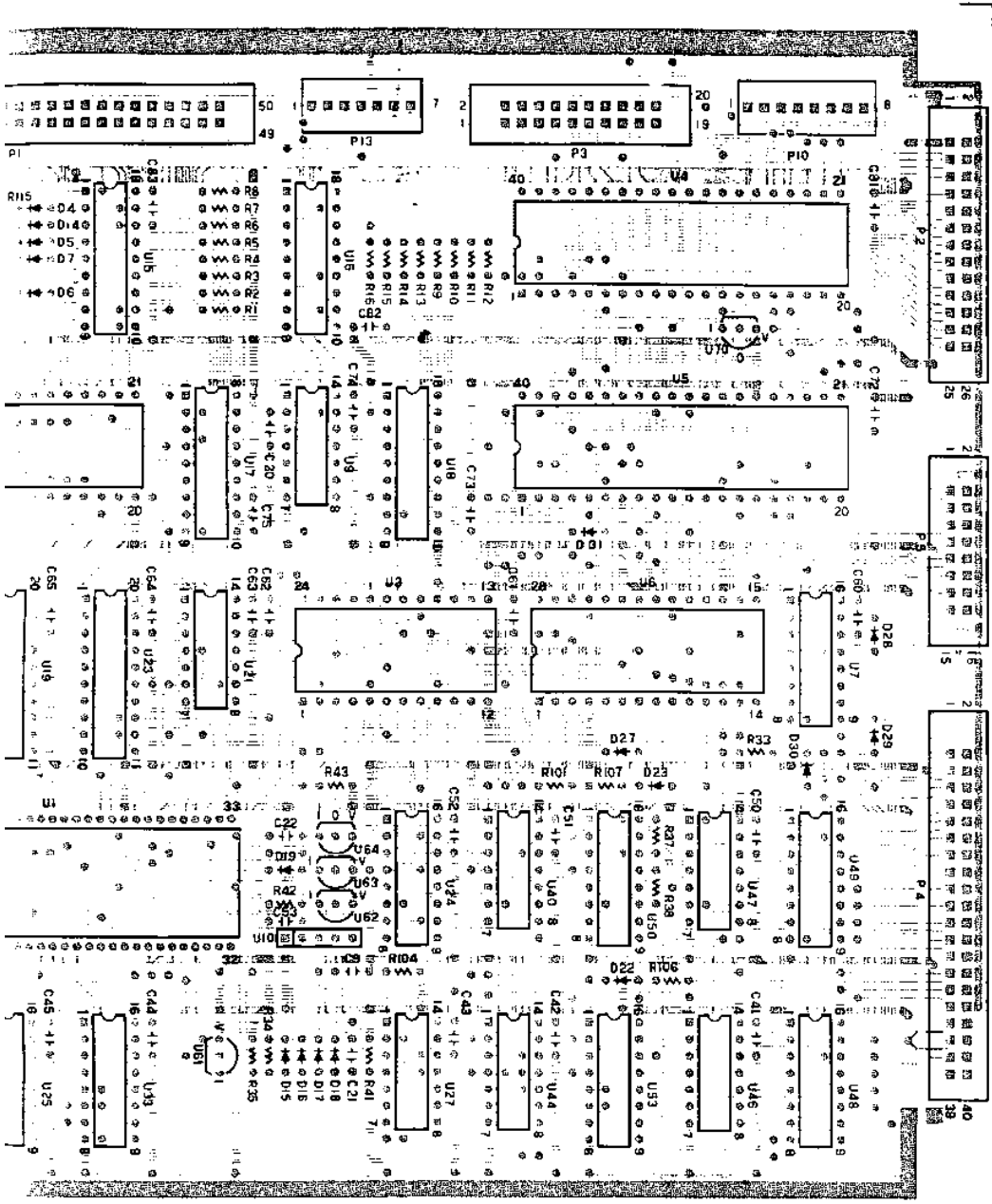

Operation PBC Ass'y

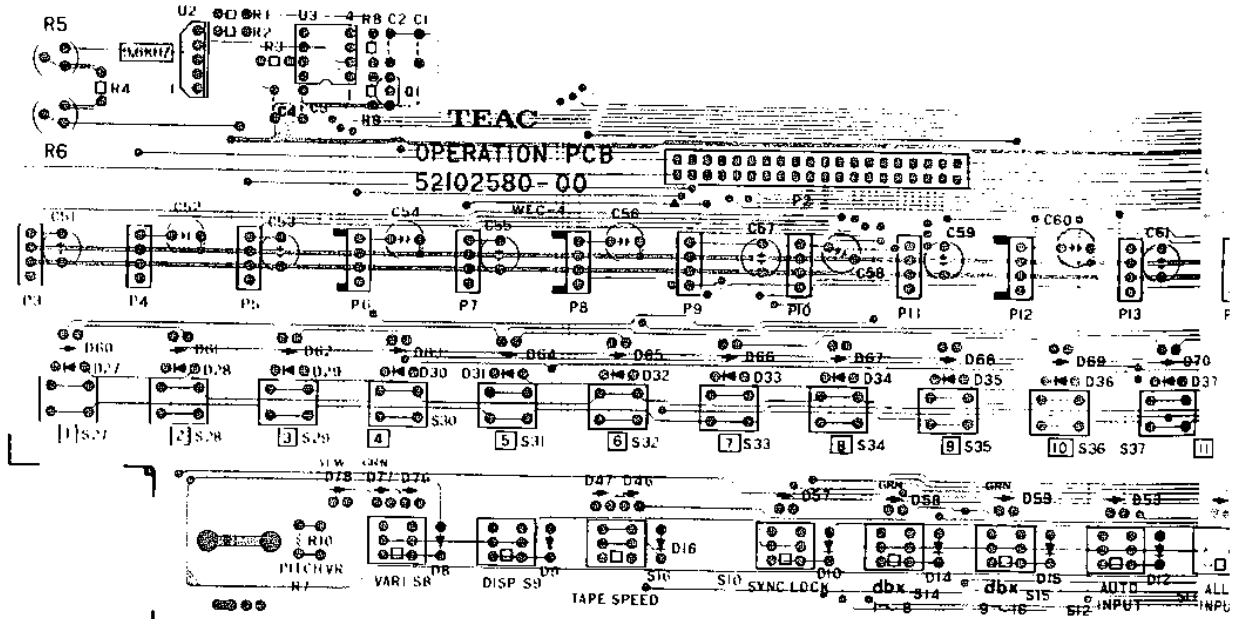

Mother PCB Ass'y

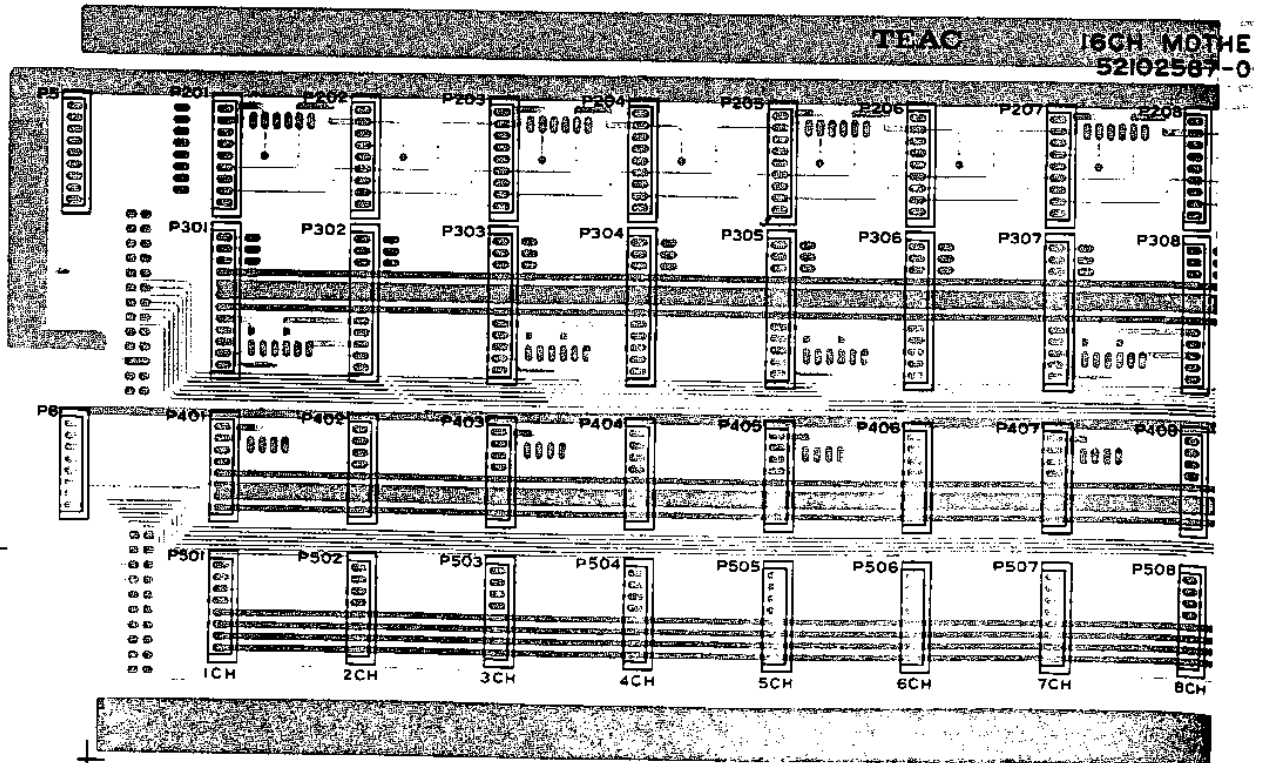

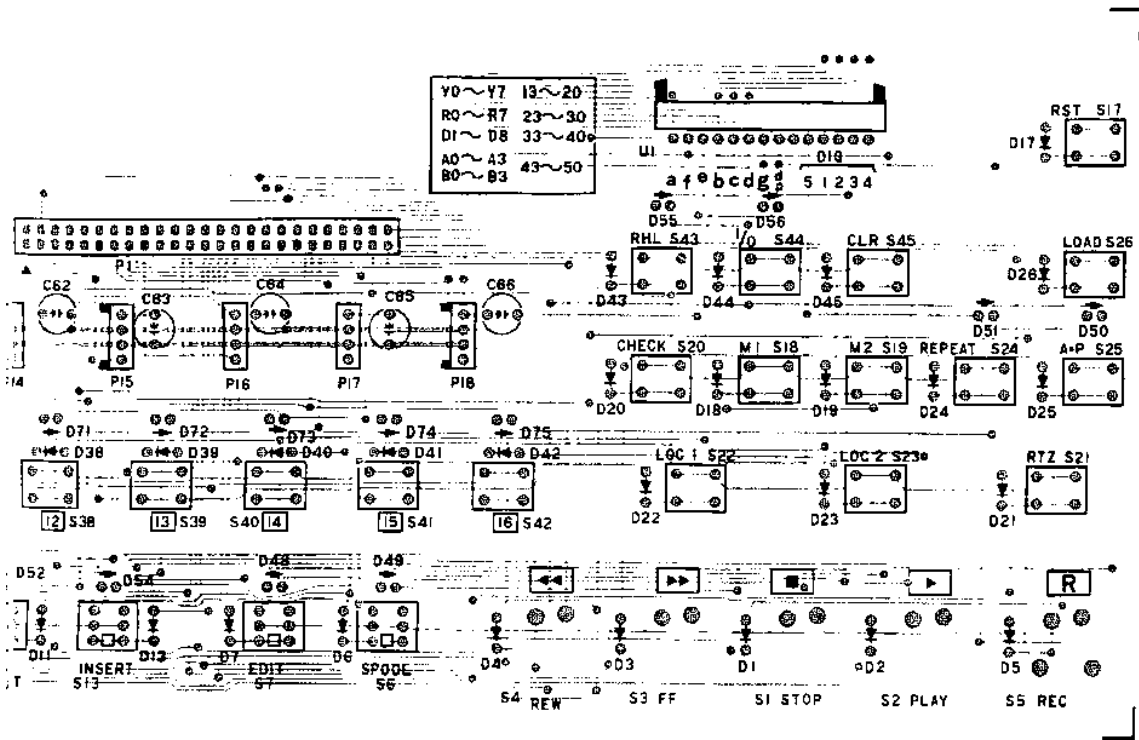

PCB (PARTS SIDE)

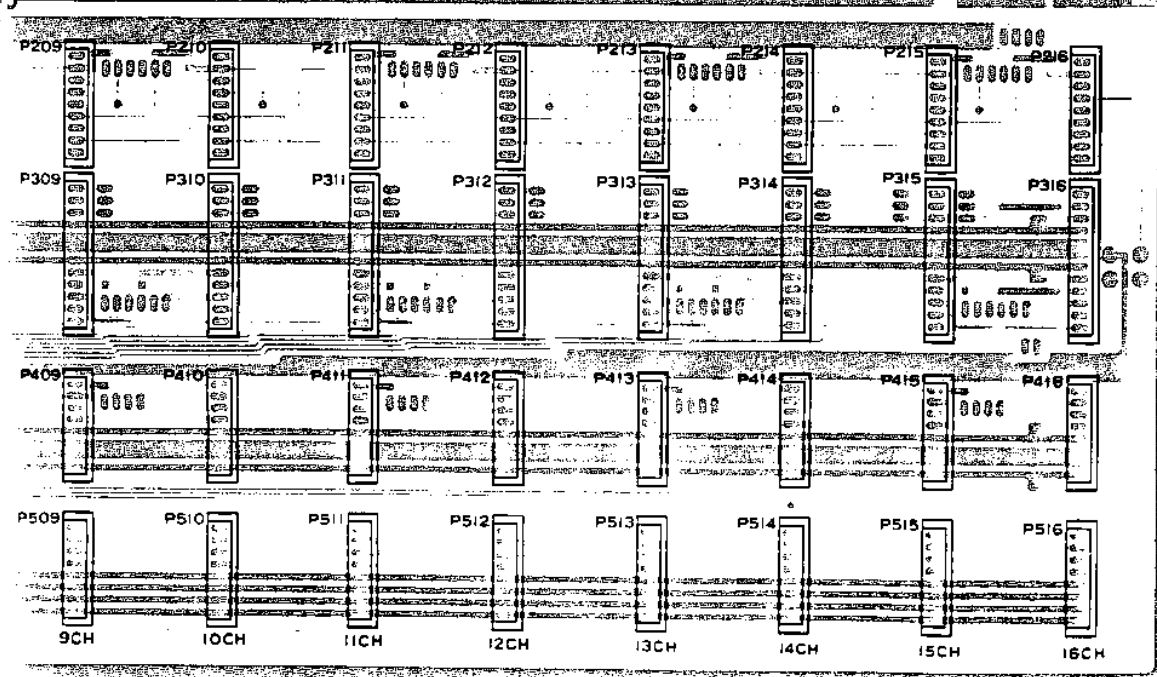

R/P PCB Ass'y

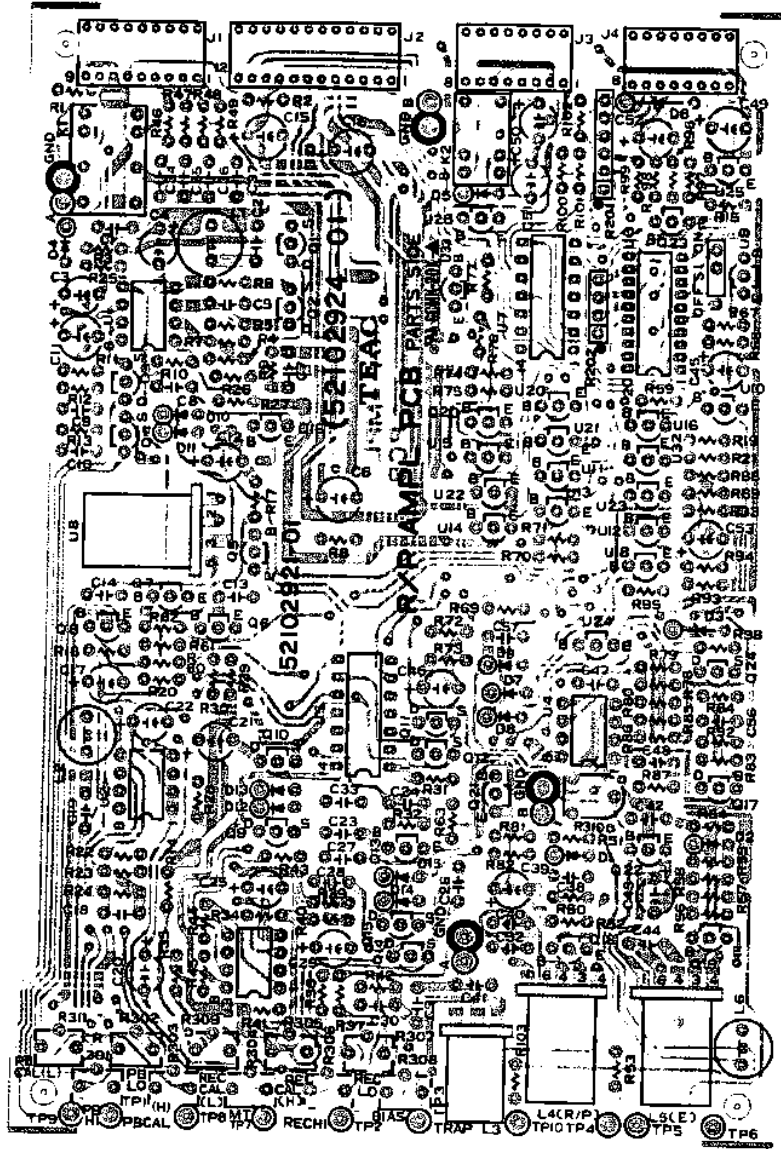

Power Supply PCB A Ass'y

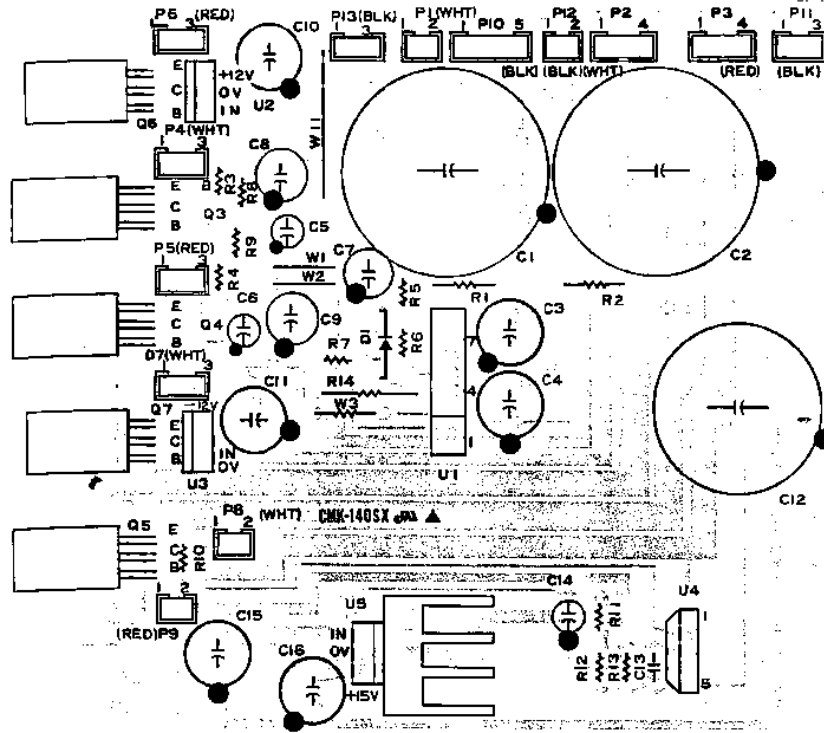

Power Supply PCB B Ass'y

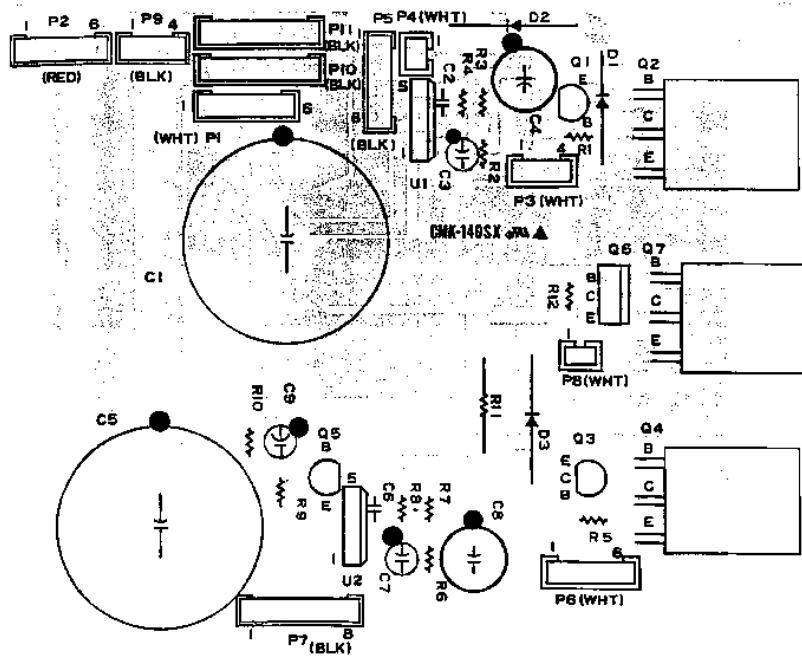

Capstan Servo PCB Ass'y

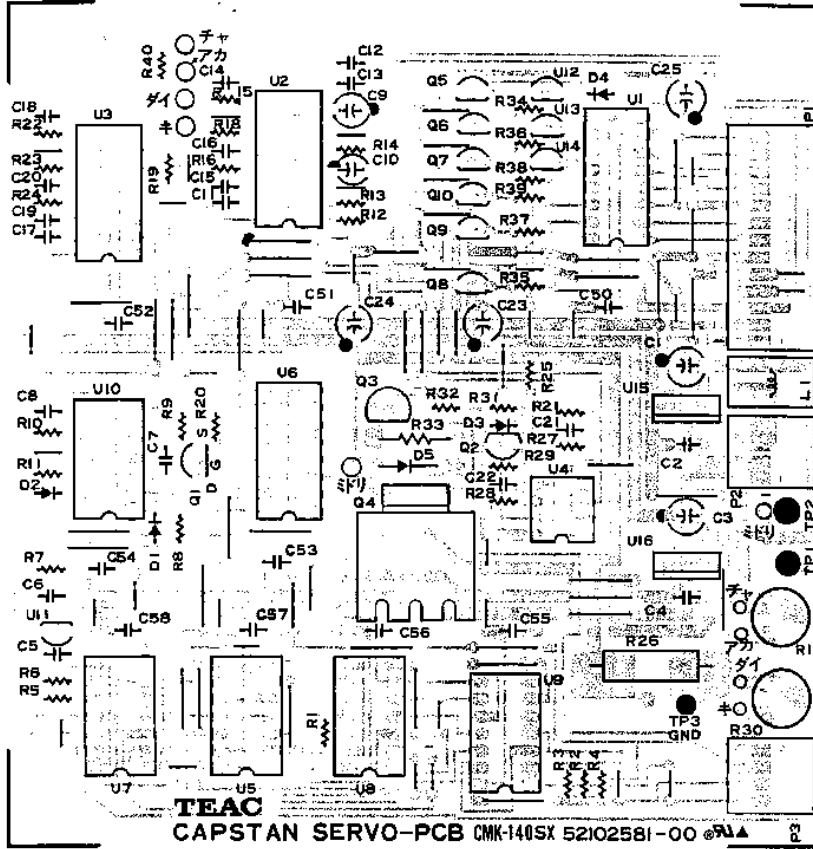

Fuse PCB Ass'y

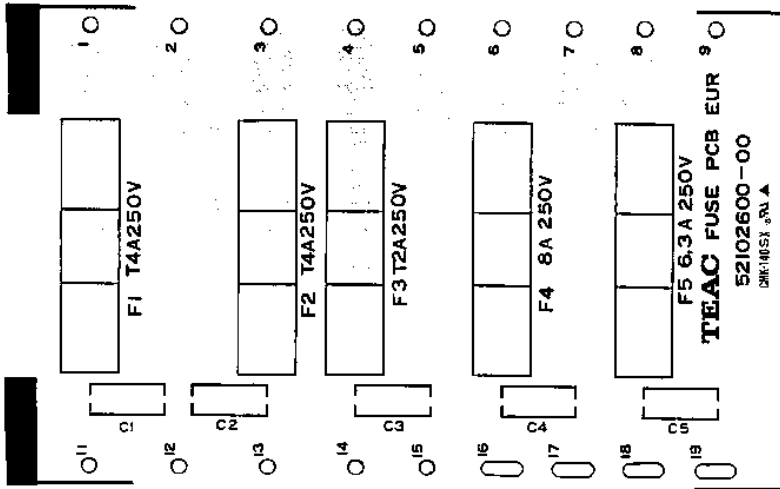
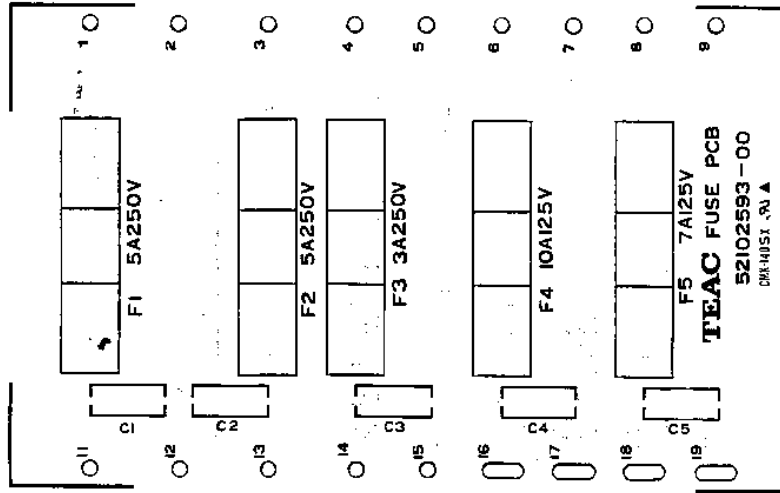

VR/OSC PCB Ass'y

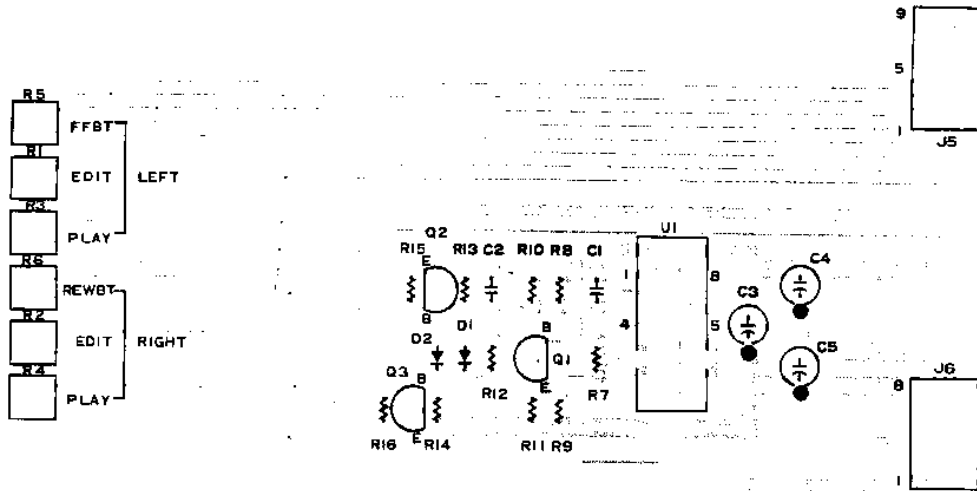

Joint PCB Ass'y

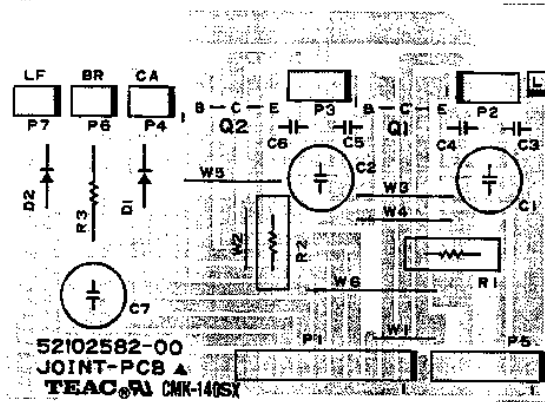

Filter PCB Ass'y

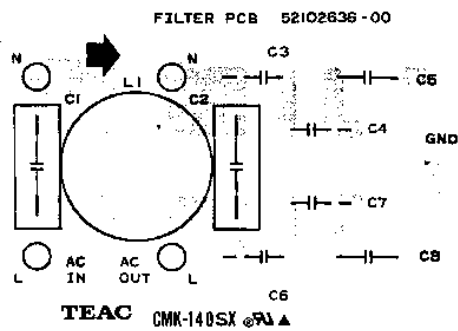

In/Out PCB Ass'y

TEAC IN/OUT PCB 52102594-00 CMK-140SX

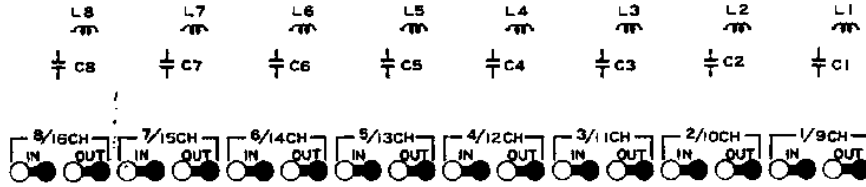

Head PCB Ass'y

Sensor PCB L Ass'y

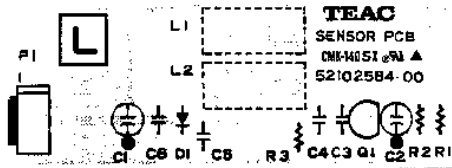

Sensor PCB R Ass'y

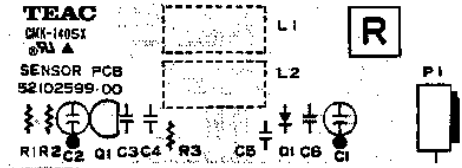

Baud Rate PCB Ass'y,

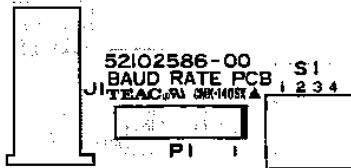

PG PCB Ass'y,

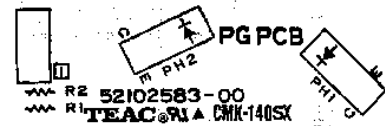

Shut PCB Ass'y,

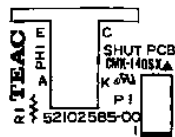

Diode PCB

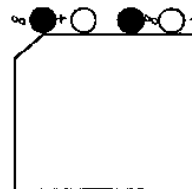

CONTROL PCB ASSY

REF.NO.	PARTS NO.	DESCRIPTION
	*5200257902	CONTROL PCB ASSY
	*5210257900	CONTROL PCB
	*5332016900	IC., SOCKET 64P
	*5220814100	IC., HD63701Y0
	*5334042400	SOCKET, CONN. 2P
	*5801142800	BRACKET(L)
	*5801142900	BRACKET(R)
	*5780103006	SCREW, PAN M3X6
	*5801143000	HOLDER, BRACKET
	*5581059000	ROD, D
C21	5263167623	C., METAL 0.056UF 50V J VT
C24	5263168123	C., METAL 0.15MF/50V J VT
C27	5263168123	C., METAL 0.15MF/50V J VT
CR1	5347004700	OSC., CRYSTAL 1.8434MHZ
CR2	5347001600	OSC., CRYSTAL 4.9152MHZ
CR3	5347011300	OSC., CERAMIC 700KHZ
D1-20	5224015010	DIODE, ISS133HV
D21	5224015010	DIODE, ISS133HV
D22 D23	5224015010	DIODE, ISS133HV
D24-26	5224015010	DIODE, ISS133HV
D27-33	5224015010	DIODE, ISS133HV
P1	5336213900	SOCKET, CONN. 5332-50GS1
P2	5336213600	SOCKET, CONN. 5332-26GS1
P3	5336213500	SOCKET, CONN. 5332-20GS1
P4	5336213800	SOCKET, CONN. 5332-40GS1
P5	5336213400	SOCKET, CONN. 5332-16GS1
P6	5336203000	PLUG, CONN. 5483-10A (WHT)
P7	5336203000	PLUG, CONN. 5483-10A (WHT)
P8	5336204300	PLUG, CONN. 5483-03A (RED)
P9	5336206300	PLUG, CONN. 5483-03A (BLK)
P10	5336202800	PLUG, CONN. 5483-08A (WHT)
P11	5336202400	PLUG, CONN. 5483-04A (WHT)
P12	5336206400	PLUG, CONN. 5483-04A (BLK)
P13	5336202700	PLUG, CONN. 5483-07A (WHT)
P14	5336202300	PLUG, CONN. 5483-03A (WHT)
Q1 Q2	5145077000	TR., 2SD-600
Q3-5	5231755400	TR., 2SD794Q
R36	5242118600	R., ARRAY RMLS BJ103
R102 R103	5150281000	R., TRIMMER 100KB V, METAL
S1	5302104800	DIP SW, SSGM
S2	5334042600	PLUG, CONN. DSP02-004-431T
U1	5220815101	MICROPROCESSOR
U2	5220805800	IC., M5L8279P-5
U3	5220810700	IC., M5M82C54P-6
U4	5220810800	IC., M5M82C55AP-5
U5	5220810800	IC., M5M82C55AP-5
U6	5220810600	IC., M5M82C51AP
U7	5220063700	IC., SPG8640CN
U8	5220062400	IC., M75188P
U9	5220062700	IC., M75189AP
U10	5220430600	IC., M519538L
U11	5220052000	IC., TC74HC32P
U12	5220052000	IC., TC74HC32P
U13	5220055900	IC., TC74HC138P
U14	5220055900	IC., TC74HC138P

CONTROL PCB ASSY

REF.NO.	PARTS NO.	DESCRIPTION
U15	5232257600	TR., ARRAY M54581P
U16	5232257600	TR., ARRAY M54581P
U17	5232256900	TR., ARRAY M54585P
U18	5232256900	TR., ARRAY M54585P
U19	5220052700	IC., TC74HC245P
U20	5220052300	IC., TC74HC139P
U21	5220051700	IC., TC74HC02P
U22	5220055700	IC., TC74HC10P
U23	5220052600	IC., TC74HC244P
U24	5220052900	IC., TC74HC390P
U25	5220052900	IC., TC74HC390P
U26	5220040800	IC., TC74HC74P
U27	5220051800	IC., TC74HC04P
U28	5220051900	IC., TC74HC14P
U29	5220040800	IC., TC74HC74P
U30	5220052900	IC., TC74HC390P
U31	5220052200	IC., TC74HC86P
U32	5220040900	IC., UPD74HCJ04C
U33	5220053100	IC., TC74HC4040P
U34	5220051600	IC., TC74HC00P
U35	5220051600	IC., TC74HC00P
U36	5220051600	IC., TC74HC00P
U37	5220055700	IC., TC74HC10P
U38	5220051600	IC., TC74HC00P
U39	5220053100	IC., TC74HC4040P
U40	5220051800	IC., TC74HC04P
U41	5220051800	IC., TC74HC04P
U42	5220051600	IC., TC74HC00P
U43	5220051600	IC., TC74HC00P
U44	5220051800	IC., TC74HC04P
U45	5220051800	IC., TC74HC04P
U46	5220051800	IC., TC74HC04P
U47	5220051800	IC., TC74HC04P
U48	6048661000	IC., M54517P
U49	6048661000	IC., M54517P
U50	6048661000	IC., M54517P
U51	6048661000	IC., M54517P
U52	5293000900	TR., ARRAY TD62504P
U53	5293000900	TR., ARRAY TD62504P
U54	6048661000	IC., M54517P
U55	6048609000	IC., LM2902N
U56	5220013400	IC., TC4066BP
U57	5220051800	IC., TC74HC04P
U58	5293000900	TR., ARRAY TD62504P
U61	5232255720	TR., DIGI. DTC124ES
U62	5232255720	TR., DIGI. DTC124ES
U63	5232255720	TR., DIGI. DTC124ES
U64	5232255720	TR., DIGI. DTC124ES
U65	5232255720	TR., DIGI. DTC124ES
U66	5232254820	TR., DIGI. DTA124ES
U67	5232254820	TR., DIGI. DTA124ES
U68	5232254820	TR., DIGI. DTA124ES
U69	5232254820	TR., DIGI. DTA124ES
U70	5232254820	TR., DIGI. DTA124ES

Parts marked with *require longer delivery time.

OPERATION PCB ASSY

REF.NO.	PARTS NO.	DESCRIPTION
	*5200258002	OPERATION PCB ASSY
	*5210258000	OPERATION PCB
	*5801143700	SPACER,BER METER
	*5780102605	SCREW,PAN M2.6X5
	*5801142100	SUPPORT,SW
	5801129100	SPACER,LED
D1-45	5224015010	DIODE,ISS133HV
D46-57	5225022000	LED,SLP-135 (RED)
D58 D59	5225022100	LED,SLP-235 (GRN)
D60-75	5225022000	LED,SLP-135 (RED)
D76	5225022000	LED,SLP-135 (RED)
D77	5225022100	LED,SLP-235 (GRN)
D78	5225022200	LED,SLP-435 (YEL)
J1	5336116400	SOCKET,CONN. 3024-14CHPB
J101-116	5336115400	SOCKET,CONN. 3024-04CHPB
P1	5334046900	SOCKET,CONN. 5342-50GS1
P2	5334046800	SOCKET,CONN. 5342-40GS1
P3	5122366000	PLUG,CONN. 3022-14AD
Q1	5145151000	TR.,2SC-1815GR
R5	5280192300	R.,TRIMMER 100KB V.METAL
R6	5280191500	R.,TRIMMER 4.7KB V.METAL
R7	5282019400	R.,TRIMMER 151UVR 11 200KB
S1-4	5300033900	SW.,PUSH 1-1
S5	5300040700	SW.,PUSH KCC11921
S6-15	5300028100	SW.,PUSH SPH122A 2-2
S16	5300025700	SW.,PUSH SPH121A
S17-45	5302107700	SW.,TACT SKHHAP0001
U1	5225021900	LED INDICATOR
U2	5145155000	TR.,2SA-995F
U3	6048947000	IC.,MC1455
U101 U116	5292209200	MODULE,LEVEL METER

MOTHER PCB ASSY

REF.NO.	PARTS NO.	DESCRIPTION
	*5200258700	MOTHER PCB ASSY
	*5210258700	MOTHER PCB
	*5263167923	C.,METAL 0.1MF 50V J VT
P5	5336279900	PLUG,CONN. 9P 1L-SDA-P
P6	5336279800	PLUG,CONN. 8P 1L-SDA-P
P11-18	5336249600	PLUG,CONN. B06B-PH-K-S (WHT)
P21-36	5336253600	PLUG,CONN. B06B-PH-K-Y (YEL)
P41-48	5336255600	PLUG,CONN. B06B-PH-K-K (BLK)
P51-58	5336251400	PLUG,CONN. B04B-PH-K-R (RED)
P101	5336213600	SOCKET,CONN. 5332-26GS1
P102	5336213500	SOCKET,CONN. 5332-20GS1
P103	5336251600	PLUG,CONN. B06B-PH-K-R (RED)
P104	5336251400	PLUG,CONN. B04B-PH-K-R (RED)
P105	5336255600	PLUG,CONN. B06B-PH-K-K (BLK)
P106	5336255400	PLUG,CONN. B04B-PH-K-K (BLK)

MOTHER PCB ASSY

REF.NO.	PARTS NO.	DESCRIPTION
P107	5336249400	PLUG,CONN. B04B-PH-K-S (WHT)
P108	5336249800	PLUG,CONN. B08B-PH-K-S (WHT)
P109	5336249200	PLUG,CONN. B02B-PH-K-S (WHT)
P201-216	5336279900	PLUG,CONN. 9P 1L-SDA-P
P301-316	5336280200	PLUG,CONN. 12P 1L-SDA-P
P401-416	5336279800	PLUG,CONN. 8P 1L-SDA-P
P501-516	5336279800	PLUG,CONN. 8P 1L-SDA-P

R/P AMPL PCB ASSY

REF.NO.	PARTS NO.	DESCRIPTION
	*5200292110	R/P AMPL PCB ASSY
	*5210292101	R/P AMPL PCB
	*5210292800	COIL B PCB
	*5210325700	COIL PCB
	*5210272400	TRAP PCB
D1,2	5224015020	DIODE,ISS133T-77
D3	5224543601	DIODE,ZENER RD15EB1
D4,5	5224015020	DIODE,ISS133T-77
D6	5224571801	DIODE,ZENER RD3.0FL2
D7,8	5224015020	DIODE,ISS133T-77
D10-15	5224015020	DIODE,ISS133T-77
J1	5336281900	SOCKET,CONN. 9P 1L-SDA-S
J2	5336282200	SOCKET,CONN. 12P 1L-SDA-S
J3,4	5336281800	SOCKET,CONN. 8P 1L-SDA-S
K1	5290012700	RELAY,12V G5A-237PL
K2	5290013700	RELAY,SY-12W-K
L1	5286007600	COIL,CHOKE 3.0MH
L3	5286037300	COIL,TRAP VARIABLE 145kHz
L4	5320051500	TRANS.,BIAS
L5	5320060600	TRANS.(B),ERASE
Q1,2	5232009500	FET.,2K170BL
Q3	5232008420	FET.,2SK381D
Q4	5232008020	FET.,2SJ-40(E)
Q5	5230775020	TR.,2SC2878-B
Q6,7	5230779520	TR.,2SC1815GR
Q9	5232008020	FET.,2SJ-40(E)
Q10	5232008420	FET.,2SK381D
Q11	5232008020	FET.,2SJ-40(E)
Q12	5232008420	FET.,2SK381D
Q13	5230779520	TR.,2SC1815GR
Q14	5232008420	FET.,2SK381D
Q15	5232008020	FET.,2SJ-40(E)
Q16	5230779520	TR.,2SC1815GR
Q17	5232008020	FET.,2SJ-40(E)
Q18,19	5230782200	TR.,2SC2002L
Q20	5230012920	TR.,2SA1015GR
Q21-23	5230779520	TR.,2SC1815GR
Q24	5232008420	FET.,2SK381D
R26,27	5183578000	R.,INCOMB. 1/4W 100
R201	5242126500	R.,ARRAY RML5 104J

Parts marked with *require longer delivery time.

R/P AMPL PCB ASSY

REF.NO.	PARTS NO.	DESCRIPTION
R202	5242126700	R.,ARRAY RMLS3 472J
R301	5280035900	R.,TRIMMER 2.2KB
R302	5280036100	R.,TRIMMER 4.7KB
R303	5280036300	R.,TRIMMER 10KB
R304	5280035900	R.,TRIMMER 2.2KB
R305	5280036300	R.,TRIMMER 10KB
R306,307	5280036200	R.,TRIMMER 6.8KB
R308	5280036900	R.,TRIMMER 100KB
R309	5280036200	R.,TRIMMER 6.8KB
TP1-9	5317002100	PIN,DH CHECK IPS-1136
U1	5220439600	IC.,UPC4507C
U2-4	5220418800	IC.,M5218P
U5	5220036200	IC.,LC4966
U6	5220813800	IC.,UPD7554CS
U7	5220051600	IC.,TC74HC00P
U8	5292809000	FILTER,L,PASS 20kHz/26kHz
U9	5232254820	TR.,DIGI. DTA124ES
U10	5232255720	TR.,DIGI. DTC124ES
U11-16	5232254820	TR.,DIGI. DTA124ES
U18,20	5232254820	TR.,DIGI. DTA124ES
U21	5232255720	TR.,DIGI. DTC124ES
U22,23	5232254820	TR.,DIGI. DTA124ES
U24-26	5232255720	TR.,DIGI. DTC124ES
U32	5232254820	TR.,DIGI. DTA124ES

DBX PCB ASSY

REF.NO.	PARTS NO.	DESCRIPTION
	*5200259500	DBX PCB ASSY
	*5210259500	DBX PCB
C102 C202	5263168023	C.,METAL 0.12MF/50V J VT
C103 C203	5263168023	C.,METAL 0.12MF/50V J VT
C104 C204	5263169113	C.,METAL 1.0UF 50V J VF
C106 C206	5263166723	C.,METAL 0.010UF 50V J VT
C109 C209	5263166723	C.,METAL 0.010UF 50V J VT
C111 C211	5263167723	C.,METAL 0.068UF 50V J VT
C112 C212	5263167723	C.,METAL 0.068UF 50V J VT
C116 C216	5263168023	C.,METAL 0.12MF/50V J VT
D101 D201	5224015020	DIODE,1SS133T-77
P1	5122156000	PLUG,CONN. 5046-13A (WHT)
Q101 Q201	5230779520	TR.,2SC1815GR
Q102 Q202	5230779520	TR.,2SC1815GR
Q103 Q203	5232008400	FET.,2SK381D

DBX PCB ASSY

REF.NO.	PARTS NO.	DESCRIPTION
Q104-111	5230775020	TR.,2SC2878-B
Q112 Q212	5230012920	TR.,2SA1015GR
Q204-211	5230775020	TR.,2SC2878-B
R11 R21	5280036700	R.,TRIMMER 47KB
R12 R22	5280036700	R.,TRIMMER 47KB
R13 R23	5280021700	R.,TRIMMER 47KB
R14 R24	5280021700	R.,TRIMMER,47KB
TP1 TP2	5317002100	PIN,DH CHECK IPS-1136
U101 U201	5220414501	IC.,UPC1252H-2
U102 U202	5220414601	IC.,UPC1253H-2
U103	5220418800	IC,M5218P
U104 U204	5232254820	TR.,DIGI. DTA124ES
W101-131	5242117400	JUMPER,JPW-L5
W201-213	5181762000	JUMPER,P=7.5
W215	5181762000	JUMPER,P=7.5
W301-306	5181763000	JUMPER,P=10.0

P/SUPPLY PCB A ASSY

REF.NO.	PARTS NO.	DESCRIPTION
	*5200259001	P/SUPPLY PCB A ASSY
	*5210259000	P/SUPPLY PCB A
	*6045030000	HEAT SINK
	*5033291000	PLATE,INSULATOR
	*5033295000	TUBE,INSULATOR
	*5801143200	HEAT SINK(A)
	*5780103006	SCREW,PAN M3X6
	*5780103010	SCREW,PAN M3X10
C1 C2	△ 5262013400	C.,ELEC. 4700UF 35V(SME) VR
C12	△ 5262013300	C.,ELEC. 2200UF 50V(SME) VR
C13	5263166723	C.,METAL 0.010UF 50V J VT
D1	5143243000	DIODE,ERB12-02G1
P1	5336249200	PLUG,CONN. B02B-PH-K-S (WHT)
P2	5336249400	PLUG,CONN. B04B-PH-K-S (WHT)
P3	5336251400	PLUG,CONN. B04B-PH-K-R (RED)
P4	5336249300	PLUG,CONN. B03B-PH-K-S (WHT)
P5	5336251300	PLUG,CONN. B03B-PH-K-R (RED)
P6	5336251300	PLUG,CONN. B03B-PH-K-R (RED)
P7	5336249300	PLUG,CONN. B03B-PH-K-S (WHT)
P8	5336249200	PLUG,CONN. B02B-PH-K-S (WHT)
P9	5336251200	PLUG,CONN. B02B-PH-K-R (RED)
P10	5336255500	PLUG,CONN. B05B-PH-K-K (BLK)
P11	5336255300	PLUG,CONN. B03B-PH-K-K (BLK)
P12	5336255200	PLUG,CONN. B02B-PH-K-K (BLK)
P13	5336255300	PLUG,CONN. B03B-PH-K-K (BLK)
Q3 Q5	△ 5145087000	TR.,2SD-313E
Q4	△ 5145129000	TR.,2SB-507
Q6	△ 5122300000	PLUG,CON. 5045-03A (RED)
Q7	△ 5122184000	PLUG,CON. 5045-03A (BLK)
R1 R2	△ 5183578000	R.,INCOMBUSTIBLE 1/4W 100

Parts marked with *require longer delivery time.

P/SUPPLY PCB A ASSY

REF.NO.	PARTS NO.	DESCRIPTION
R3 R4	5240027620	R., CARBON 560 OHM R-10 T
R5	5241461120	R., METAL FILM CRB20 16K
R6	5241459220	R., METAL FILM CRB20 2.7K
R7	5241459420	R., METAL FILM 3.3K
R8 R9	5241461020	R., METAL FILM 15K
R11	5241461920	R., METAL FILM CRB20 36K
R12	5241459820	R., METAL FILM CRB20 4.7K
R13	5241459420	R., METAL FILM 3.3K
R14	△ 5241217110	R., NONFLAMMABLE 1W 47 OHM
U1	5220425800	IC., M5230LA
U2	△ 5220434800	IC., M5F7812L
U3	△ 5220435700	IC., M5F7912L
U4	5220418300	IC., M5231L
U5	△ 5220434900	IC., M5F7815L
W1-3	5181763000	JUMPER, P=10.0
W11	5181768000	JUMPER, P=22.5

P/SUPPLY PCB B ASSY

REF.NO.	PARTS NO.	DESCRIPTION
	*5200259100	P/SUPPLY PCB B ASSY
	*5210259100	P/SUPPLY PCB B
	*5801143300	HEAT SINK(B)
	*5780103006	SCREW, PAN M3X6
	*5780103010	SCREW, PAN M3X10
C1	△ 5262013500	C., ELEC. 15000UF 35V(SME) VR
C2	5263166723	C., METAL 0.010UF 50V J VT
C5	△ 5262013600	C., ELEC. 22000UF 16V(SME) VR
C6	5263166723	C., METAL 0.010UF 50V J VT
D1-3	△ 5224014700	DIODE, S3V20H
P1	5336249600	PLUG, CONN. B06B-PH-K-S (WHT)
P2	5336251600	PLUG, CONN. B06B-PH-K-R (RED)
P3	5336249400	PLUG, CONN. B04B-PH-K-S (WHT)
P4	5336249200	PLUG, CONN. B02B-PH-K-S (WHT)
P5	5336253600	PLUG, CONN. B06B-PH-K-K (BLK)
P6	5336249600	PLUG, CONN. B06B-PH-K-S (WHT)
P7	5336255800	PLUG, CONN. B08B-PH-K-K (BLK)
P8	5336249200	PLUG, CONN. B02B-PH-K-S (WHT)
P9	5336255400	PLUG, CONN. B04B-PH-K-K (BLK)
P10 P11	5336255800	PLUG, CONN. B08B-PH-K-K (BLK)
Q1 Q3	5230771000	TR., 2SC2274-KE
Q2 Q4	△ 5231758800	TR., 2SD1047-E
Q5	5230771000	TR., 2SC2274-KE
Q6	5145129000	TR., 2SB-507
Q7	△ 5145169000	TR., 2SD-7160
R2	5241461120	R., METAL FILM CRB20 16K
R3	5241459220	R., METAL FILM CRB20 2.7K
R4	5241459420	R., METAL FILM 3.3K
R6	5241460020	R., METAL FILM CRB20 5.6K
R7	5241456820	R., METAL FILM CRB20 270 OHM
R8	5241459420	R., METAL FILM 3.3K
R11	△ 5241224510	R., NONFLAMMABLE 2W 470 OHM
U1 U2	5220418300	IC., M5231L

C/SERVO PCB ASSY

REF.NO.	PARTS NO.	DESCRIPTION
	*5200258101	C/SERVO PCB ASSY
	*5210258100	C/SERVO PCB
	*5181761000	JUMPER, P=5.0
	*5181762000	JUMPER, P=7.5
	*5181763000	JUMPER, P=10.0
	*6045030000	HEAT SINK
	*5033291000	PLATE, INSULATOR
	*5033295000	TUBE, INSULATOR
	*5780103008	SCREW, PAN M3X8
C2	5263167923	C., METAL 0.1MF 50V J VT
C4	5263167923	C., METAL 0.1MF 50V J VT
D1-4	5224015010	DIODE, 1SS133HV
D5	5143243000	DIODE, ERB12-02G1
L1	6046628000	COIL, CHOKE SN-8S-400
P1	5122156000	PLUG, CONN. 5046-13A (WHT)
P2	5122455000	PLUG, CONN. 5046-04A (RED)
P3	5122147000	PLUG, CONN. 5046-04A (WHT)
Q1	5145102000	FET., 2SK-68A-L
Q2	5145150000	TR., 2SA-1015GR
Q3	5230773800	TR., 2SC2655-Y
Q4	5231755100	TR., 2SD880Y
Q5-7	5230014000	TR., 2SA1020-Y
Q8-10	5230773800	TR., 2SC2655-Y
R17	5280132702	R., TRIMMER 20KB V.METAL
R26	△ 5184590000	R., INCOMBUSTIBLE 2W 1 OHM
R30	5280132002	R., TRIMMER 5.0KB V.METAL
R33	△ 5180050000	R., CARBON 47 OHM
TP1-3	5317002100	PIN, DH CHECK 1PS-1136
U1	5220440000	IC., UPC1246C
U2	5220426600	IC., UPC1043C
U3	5220426600	IC., UPC1043C
U4	5220407200	IC., LM2904
U5	5220040800	IC., TC74HC74P
U6	5220016700	IC., HD14046BP
U7	5220051900	IC., TC74HC14P
U8	5220055700	IC., TC74HC10P
U9	5220051600	IC., TC74HC00P
U10	5220013400	IC., TC4066BP
U11	5232255720	TR., DIGI. DTC124ES
U12	5232255720	TR., DIGI. DTC124ES
U13	5232255720	TR., DIGI. DTC124ES
U14	5232255720	TR., DIGI. DTC124ES
U15	5220434800	IC., M5F7812L
U16	5220434400	IC., M5F7805L
U17	5232255720	TR., DIGI. DTC124ES

Parts marked with *require longer delivery time.

FUSE PCB ASSY

REF.NO.	PARTS NO.	DESCRIPTION
	*5200259300	FUSE PCB ASSY [J,US,C,EX]
	*5200259310	FUSE PCB ASSY [E,UK]
	*5210259300	FUSE PCB [J,US,C,EX]
	*5210260000	FUSE PCB [E,UK]
	*5041237000	HOLDER,FUSE [J,US,C,EX]
	5332014200	HOLDER,FUSE [E,UK]
C1-5	△ 5263164900	C.,METAL 0.1MF/250V [E,UK]
F1 F2	△ 5307004500	FUSE,5A 250V [J,US,C,EX]
F1 F2	△ 5142192000	FUSE,MINI;T 4A-200V [E,UK]
F3	△ 5307004300	FUSE,3A-250V [J,US,C,EX]
F3	△ 5142189000	FUSE,MINI;T 2A-250V [E,UK]
F4	△ 5307004900	FUSE,10A-250V [J,US,C,EX]
F4	△ 5307042500	FUSE,MINI;T 8A 250V [E,UK]
F5	△ 5307004700	FUSE,7A-125V [J,US,C,EX]
F5	△ 5142194000	FUSE,MINI;T 6.3A-250V [E,UK]

VR/OSC PCB ASSY

REF.NO.	PARTS NO.	DESCRIPTION
	*5200259200	VR/OSC PCB ASSY
	*5210259200	VR/OSC PCB
D1 D2	5224015010	DIODE,ISS133HV
J5	5336281900	SOCKET,CONN. 9P 1L-SDA-S
J6	5336281800	SOCKET,CONN. 8P 1L-SDA-S
Q1	5230779520	TR.,2SC1815GR
Q2	5230773800	TR.,2SC2655-Y
Q3	5230014000	TR.,2SA1020-Y
R1 R2	5280191500	R.,TRIMMER 4.7KB V.METAL
R3 R4	5280191500	R.,TRIMMER 4.7KB V.METAL
R5 R6	5280191500	R.,TRIMMER 4.7KB V.METAL
U1	5292209300	MODULE,OSC 145KHZ

JOINT PCB ASSY

REF.NO.	PARTS NO.	DESCRIPTION
	*5200258200	JOINT PCB ASSY
	*5210258200	JOINT PCB
	*5801142600	HEAT SINK(C)
	*5780103006	SCREW,PAN M3X6
	*5780103008	SCREW,PAN M3X8
D1 D2	5143243000	DIODE,ERB12-02G1
P1	5336203000	PLUG,CONN. 5483-10A (WHT)
P2	5336202300	PLUG,CONN. 5483-03A (WHT)
P3	5336202300	PLUG,CONN. 5483-03A (WHT)
P4	5336202200	PLUG,CONN. 5483-02A (WHT)
P5	5336202600	PLUG,CONN. 5483-06A (WHT)
P6 P7	5336202200	PLUG,CONN. 5483-02A (WHT)
Q1 Q2	5231758800	TR.,2SD1047-E
R1	△ 5185202000	R.,METAL PLATE 0.47 5W
R2	△ 5185202000	R.,METAL PLATE 0.47 5W
R3	△ 5241217110	R.,NONFLAMMABLE 1W 47 OHM
W1 W2	5181763000	JUMPER,P=10.0
W3-5	5181765000	JUMPER,P=15.0
W6	5181767000	JUMPER,P=20.0

FILTER PCB ASSY

REF.NO.	PARTS NO.	DESCRIPTION
	*5200263600	FILTER PCB ASSY
	*5210263600	FILTER PCB
C1 C2	5267704100	SPARK KILLER 0.0047UF250V
C3-C8	5267703800	SPARK KILLER 4700PF 400V
L1	5292806300	FILTER,NOISE FKOB16MH13

IN/OUT PCB ASSY

REF.NO.	PARTS NO.	DESCRIPTION
	*5200259400	IN/OUT PCB ASSY
	*5210259400	IN/OUT PCB
	*5330509900	JACK,PIN 16P
L1-8	5286020400	COIL,CHOKE 330UH K VR

HEAD PCB ASSY

REF.NO.	PARTS NO.	DESCRIPTION
	*5200258800	HEAD PCB ASSY
	*5210258800	HEAD PCB
J1-4	5332015300	SOCKET,IC 16P

Parts marked with *require longer delivery time.

[US]:U.S.A. [E]:EUROPE [UK]:U.K. [C]:CANADA [J]:JAPAN
[GE]:GENERAL EXPORT

SENSOR PCB L ASSY

REF.NO.	PARTS NO.	DESCRIPTION
	*5200258400	SENSOR PCB L ASSY
	*5210258400	SENSOR PCB L
	*5801138800	SPACER, SENCER COIL
DI	5224015010	DIODE, 1SS133HV
LI L2	5160038000	COIL, DETECTOR
PI	5336139300	PLUG, CONN. 8263-0311 (RED)
QI	5145036000	TR., 2SC-945LK

SENSOR PCB R ASSY

REF.NO.	PARTS NO.	DESCRIPTION
	*5200259900	SENSOR PCB R ASSY
	*5210259900	SENSOR PCB R
	*5801138800	SPCER, SENCER COIL
DI	5224015010	DIODE, 1SS133HV
LI L2	5160038000	COIL, DETECTOR
PI	5336141300	PLUG, CONN. 8263-0311 (BLK)
QI	5145036000	TR., 2SC-945LK

BAUD RATE PCB ASSY

REF.NO.	PARTS NO.	DESCRIPTION
	*5200258600	BAUD RATE PCB ASSY
	*5210258600	BAUD RATE PCB
J1	5330012600	JACK, 3P FJ332DB-M
PI	5336202700	PLUG, CONN. 5483-07A (WHT)
S1	5302107800	SW., DIP 4P

PG PCB ASSY

REF.NO.	PARTS NO.	DESCRIPTION
	*5200258300	PG PCB ASSY
	*5210258301	PG PCB
PI	5336206400	PLUG, CONN. 5483-04A (BLK)
PH1 PH2	5228005500	PHOTO INTERRUPTER, GP-3501

SHUT PCB ASSY

REF.NO.	PARTS NO.	DESCRIPTION
	*5200258500	SHUT PCB ASSY
	*5210258500	SHUT PCB
PI	5336128300	PLUG, CONN. 8263-0311 (WHT)
PH1	5228014000	PHOTO INTERRUPTER, EE-SV3-B

Parts marked with *require longer delivery time.

DBX PCB Ass'y

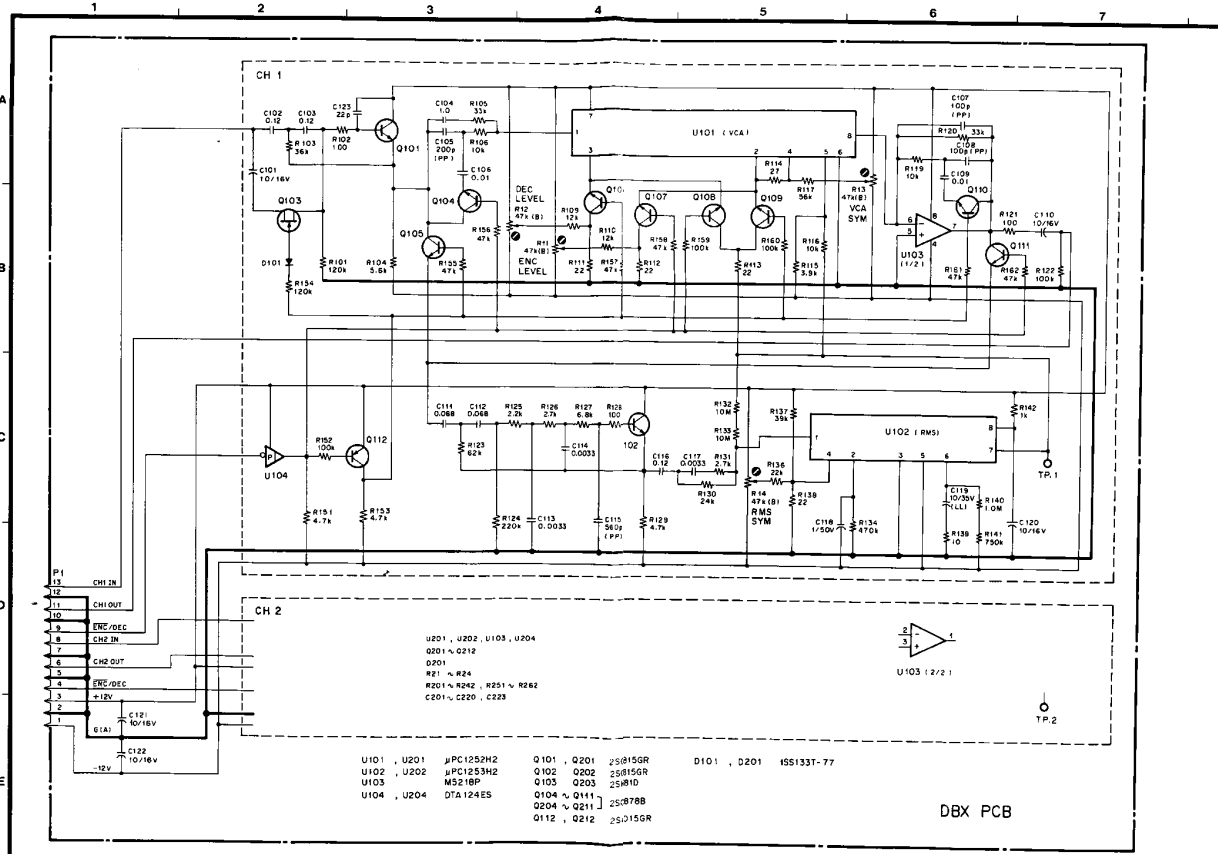

Capstan Servo PCB Ass'y

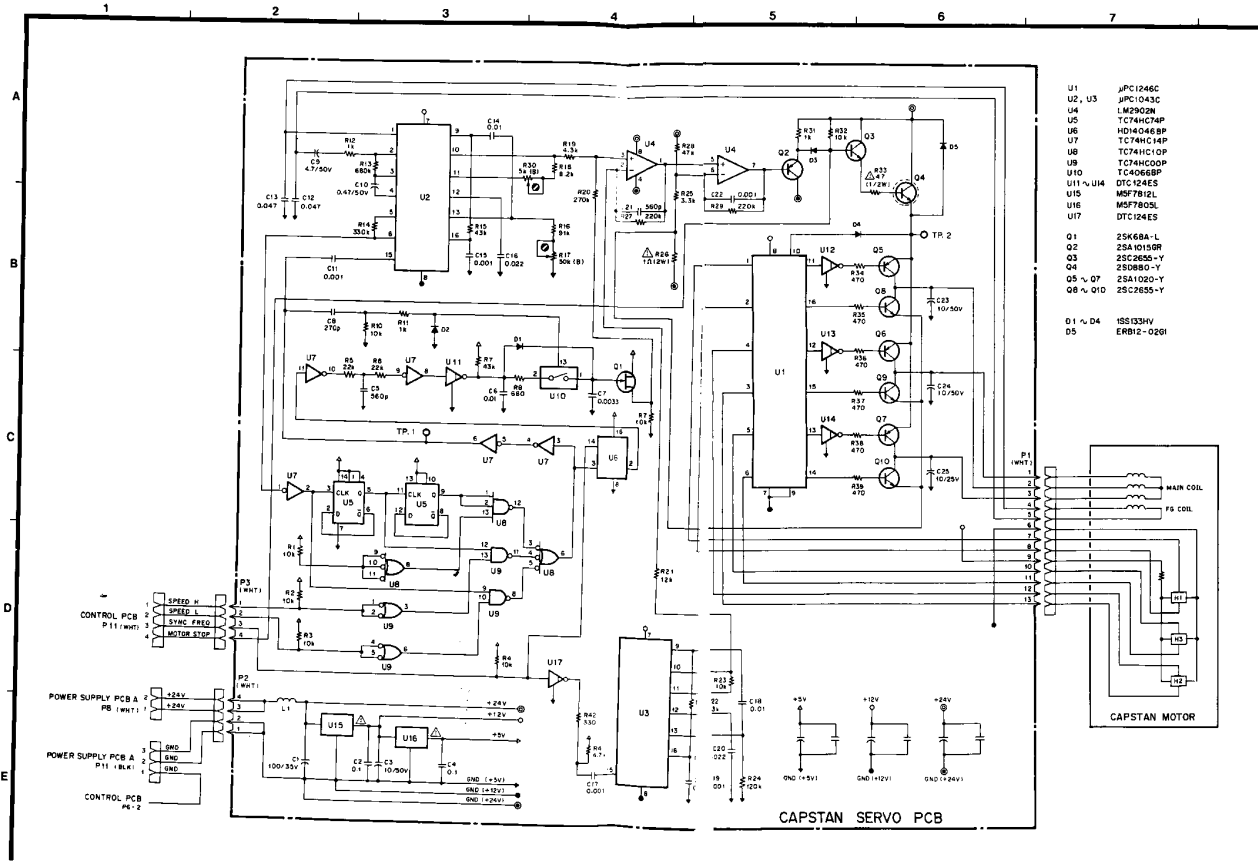

- U1 JRC1240C
- U2, U3 JRC1043C
- U4 LM2902N
- U5 TC74HC00
- U6 HD14046BP
- U7 TC74HC14P
- U8 TC74HC00P
- U9 TC74HC00P
- U10 TC4068BP
- U11 ~ U14 DTC104ES
- U15 MSF7812L
- U16 MSF7805L
- U17 DTC124ES
- Q1 2SK68A-L
- Q2 2SA1015GR
- Q3 2SC2655-Y
- Q4 2SD880-Y
- Q5 ~ Q7 2SA1025-Y
- Q8 ~ Q10 2SC2655-Y
- D1 ~ D4 1SS133HV
- D5 ERB12-0261

CAPSTAN SERVO PCB

4-4. IC Internal Block Diagrams

TC74HC00P

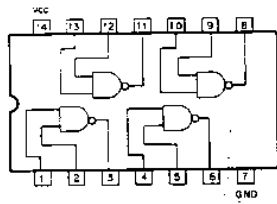

TC74HC02P

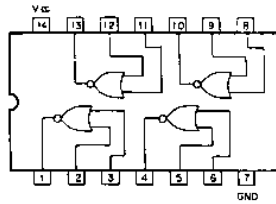

T062504P

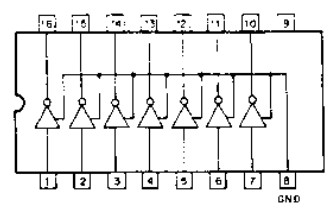

LC4966
TC4066BP

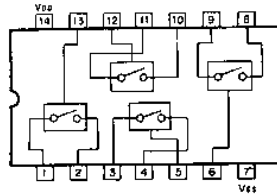

TC74HC74P

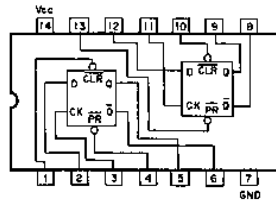

M5218P
JPC4570C

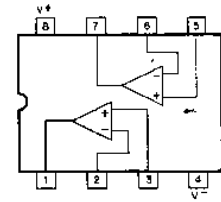

TC74HC4040P

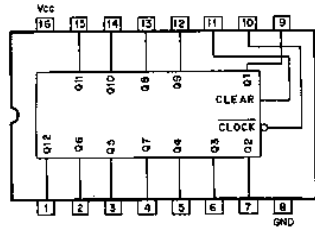

TC74HC159P

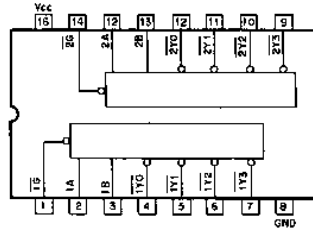

TC74HC138P

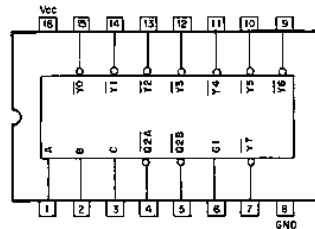

HD14046BP

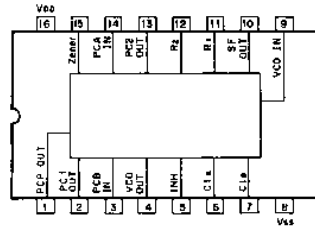

M5M82C55AP-5

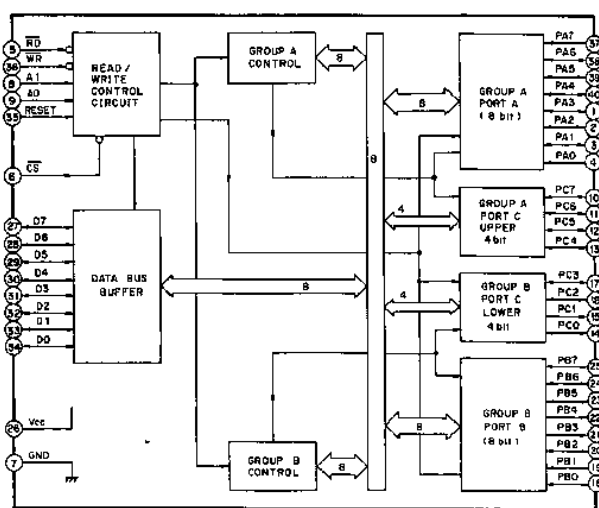

M5L0279P-5

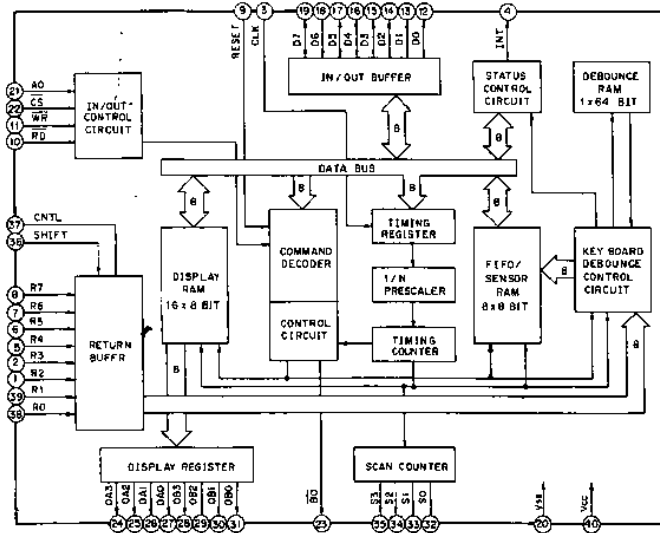

μPD7554CS-100

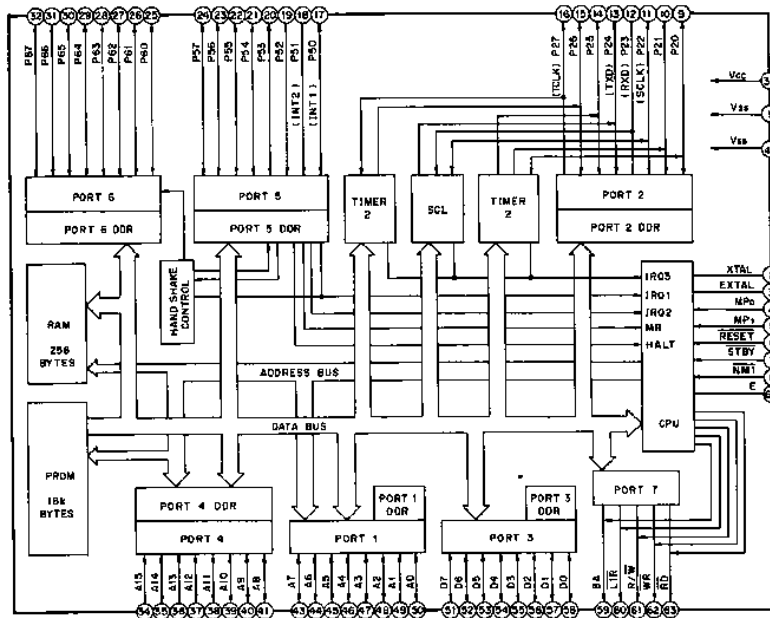

M063701YOP

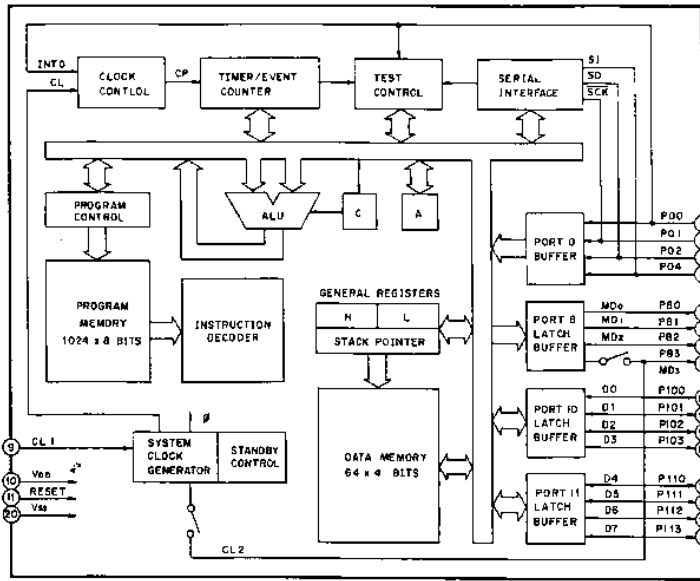

M5230L - A

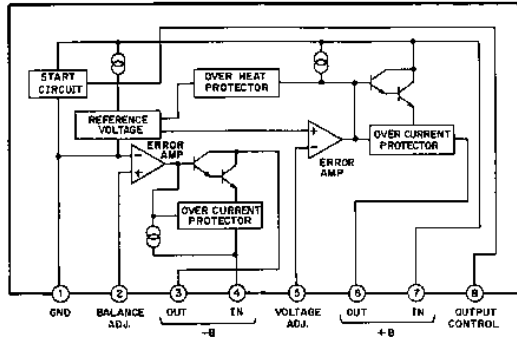

M5231L

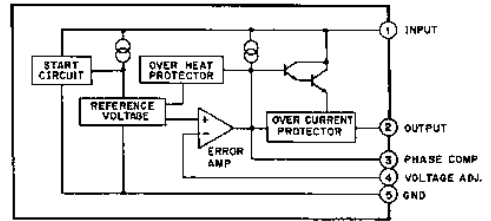

M5M82C54P - 6

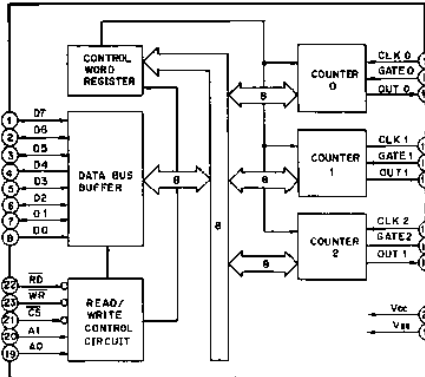

M5M82C51AP

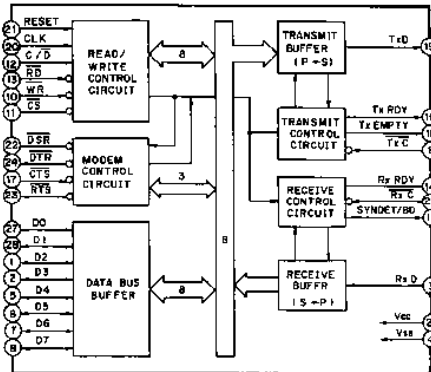

Wiring Diagram

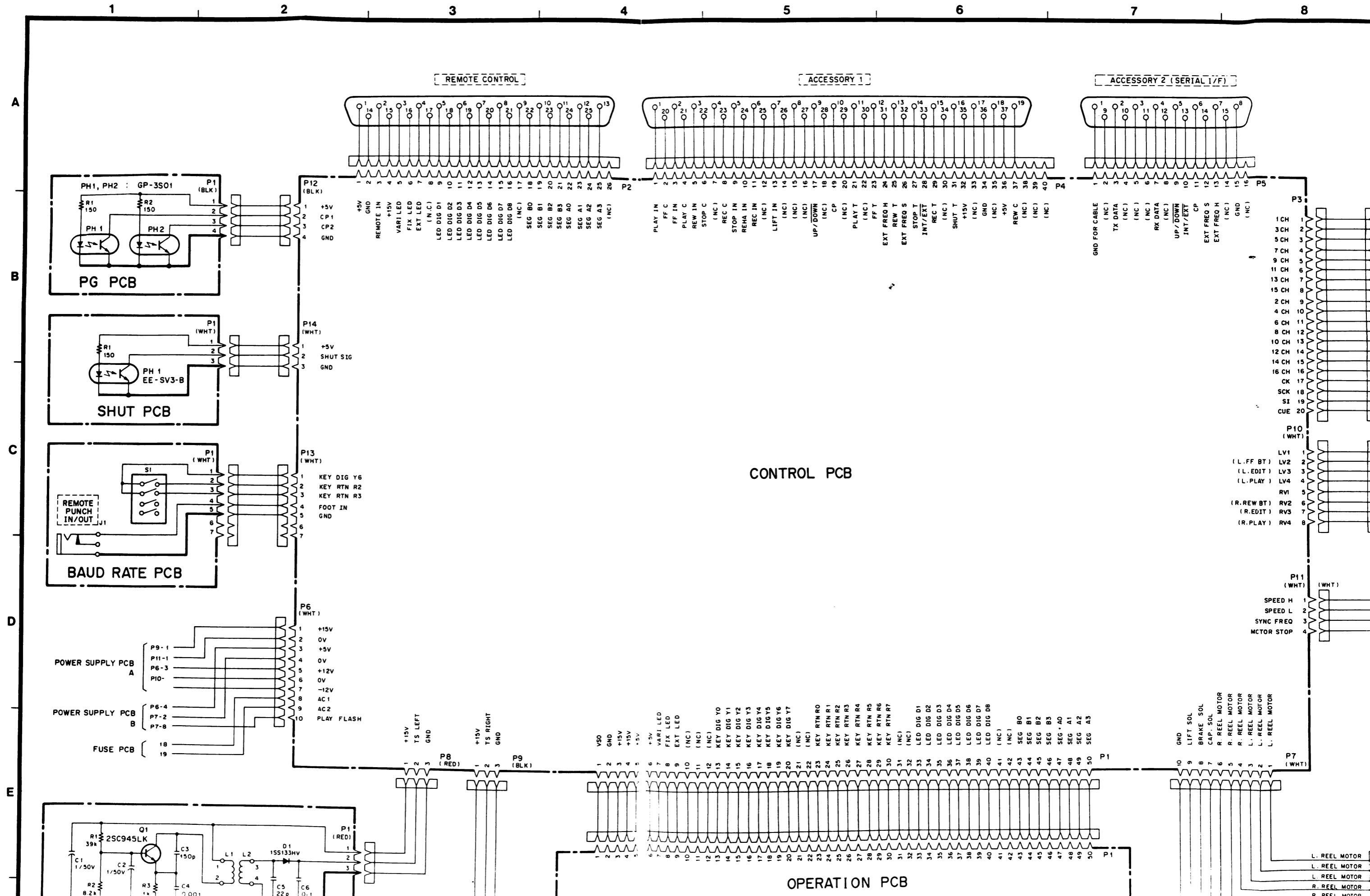

C
D
E
F
G
H

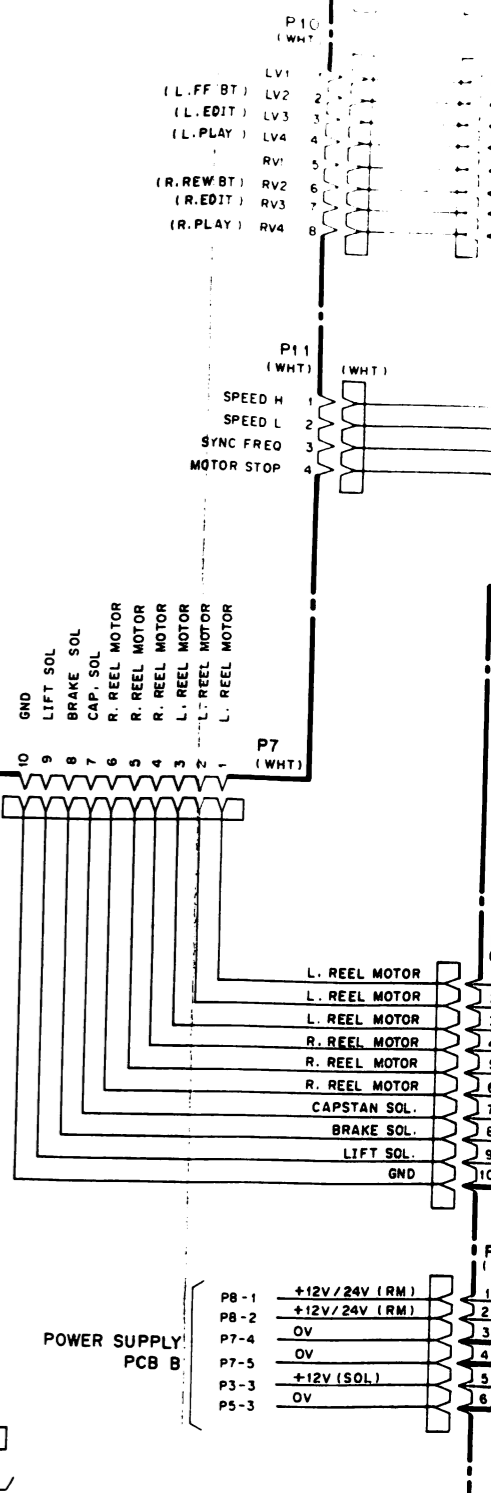
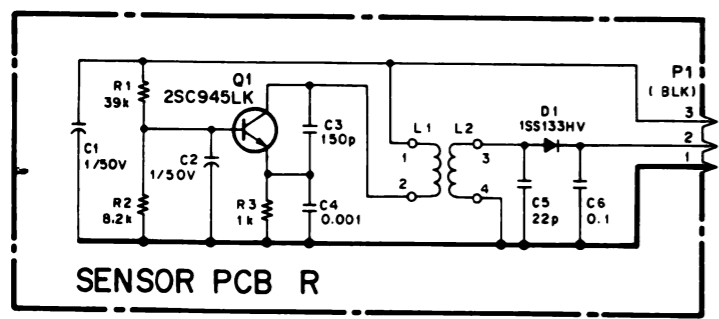
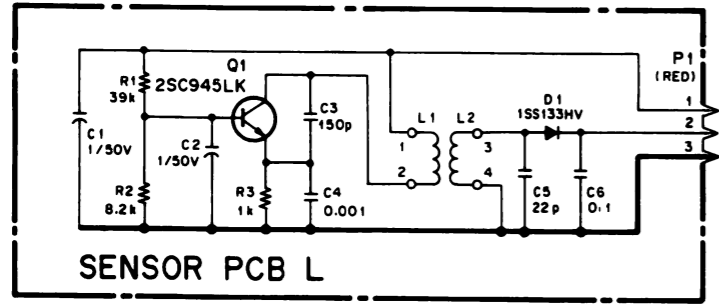
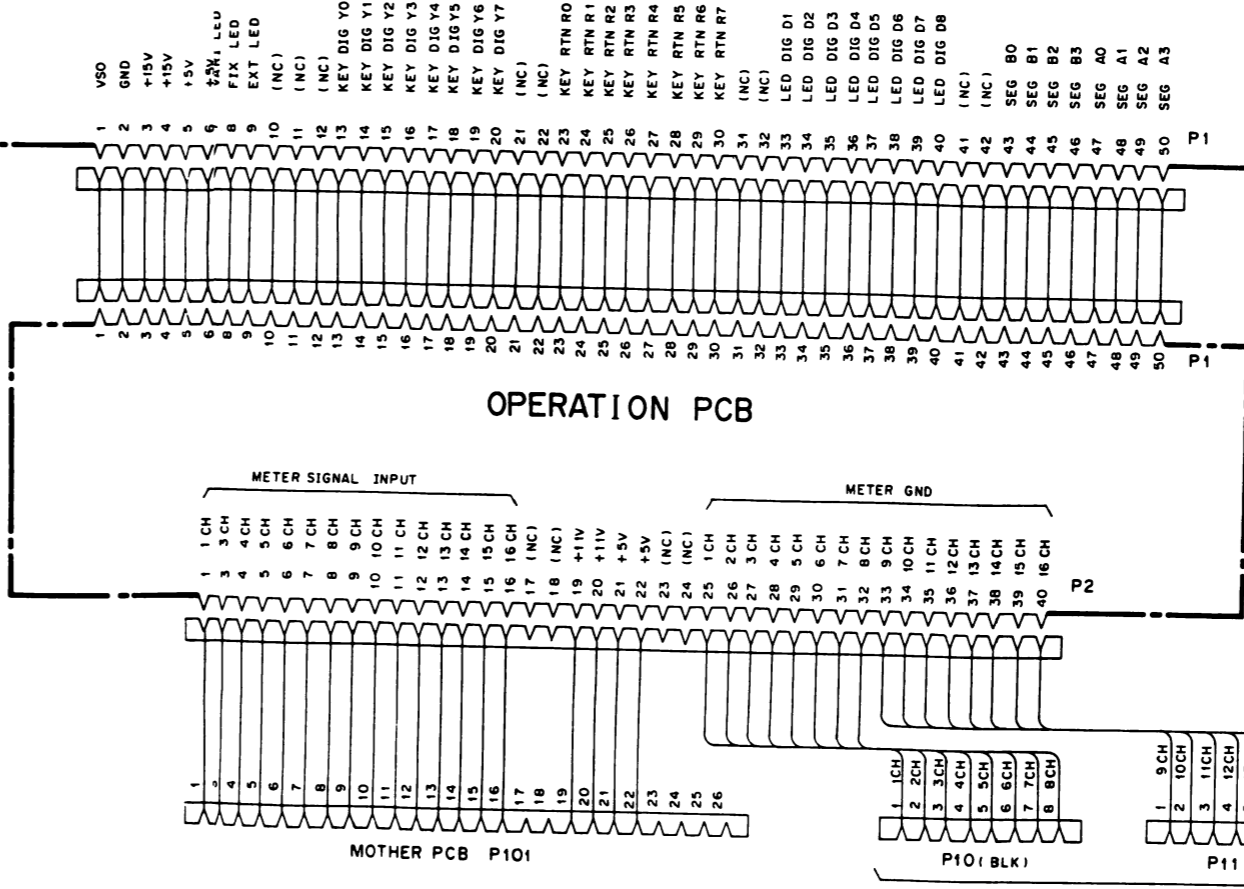
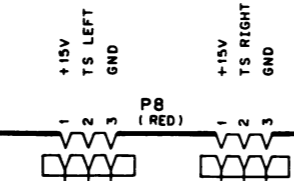
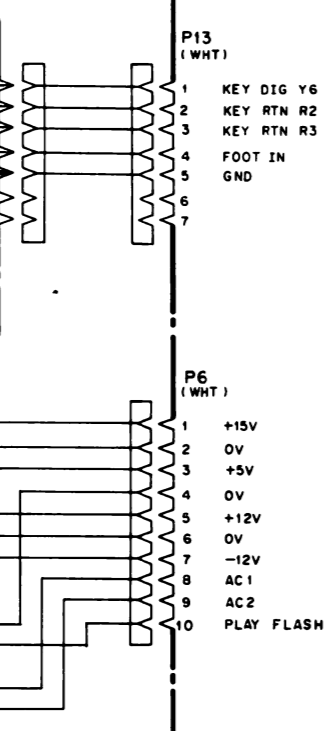
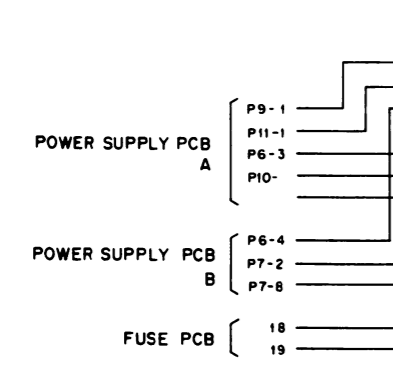
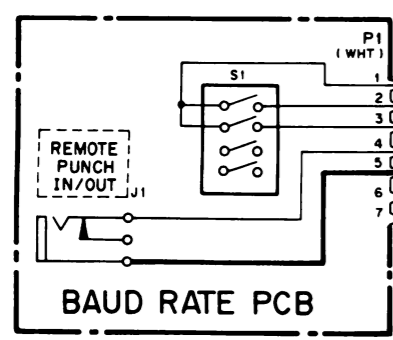
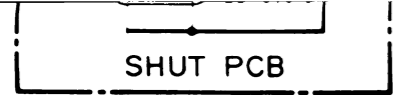

CONTROL PCB

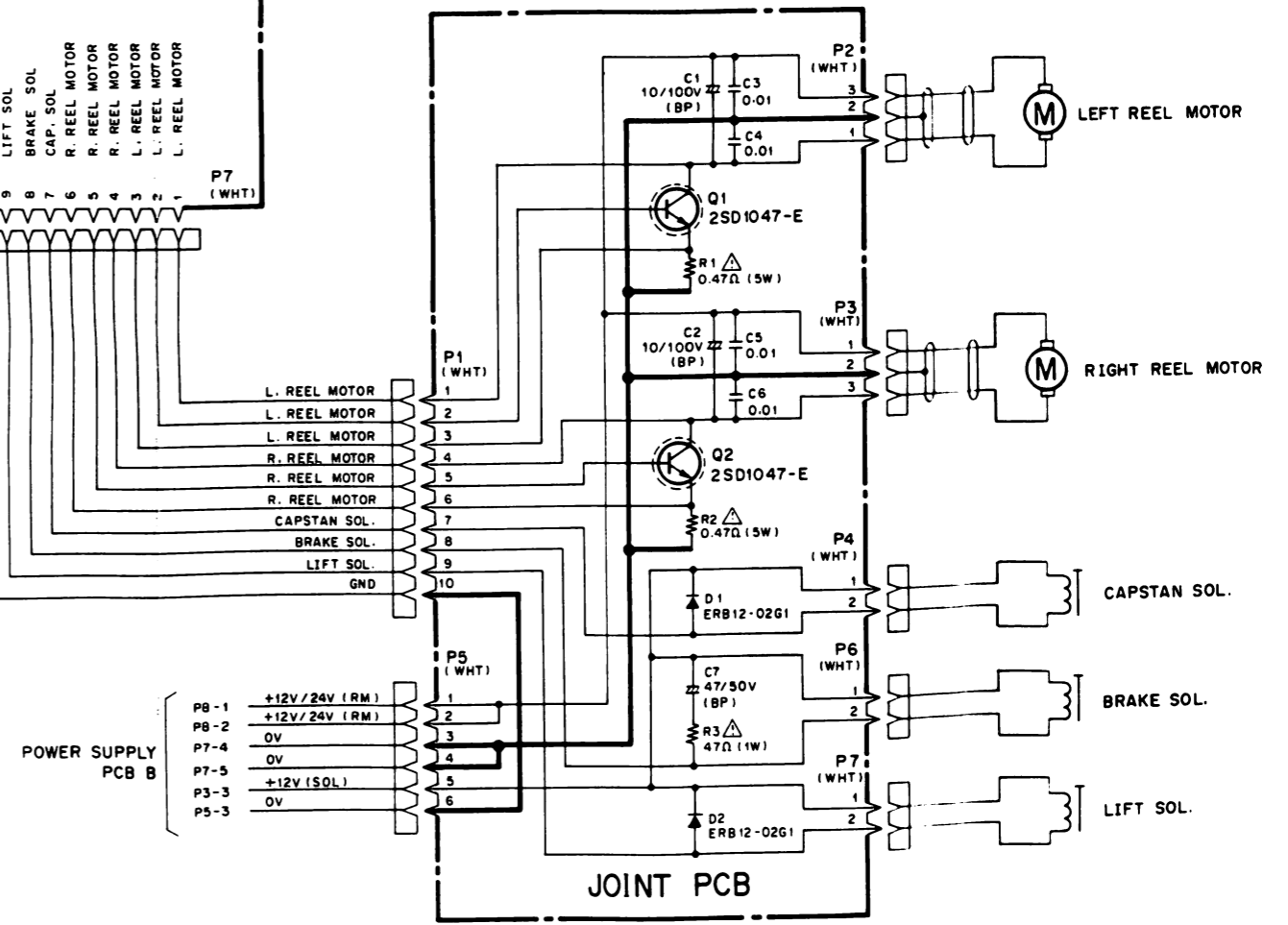
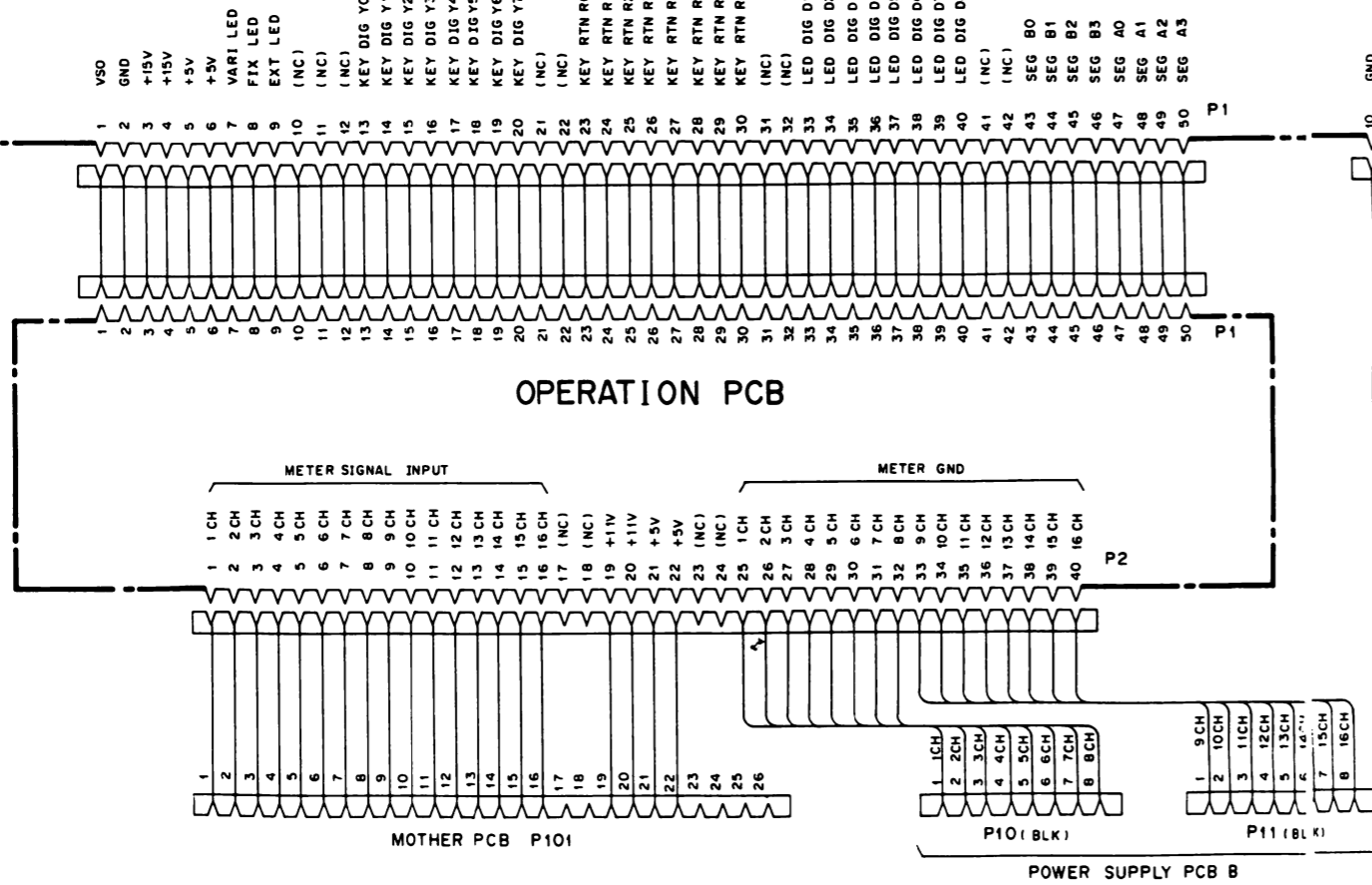
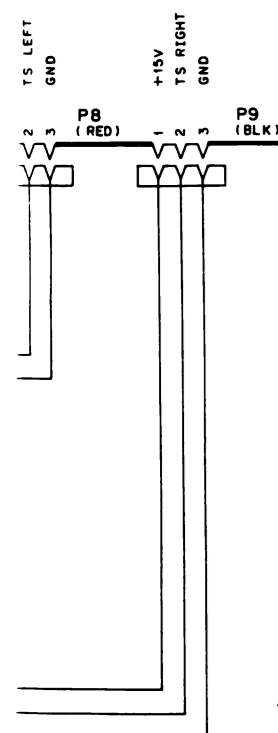
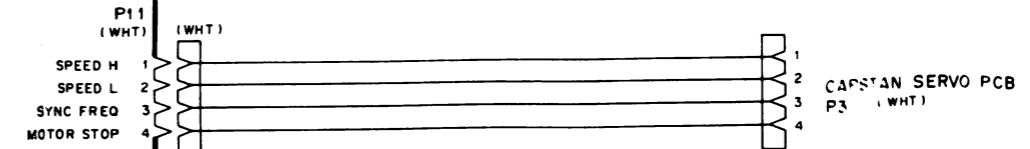
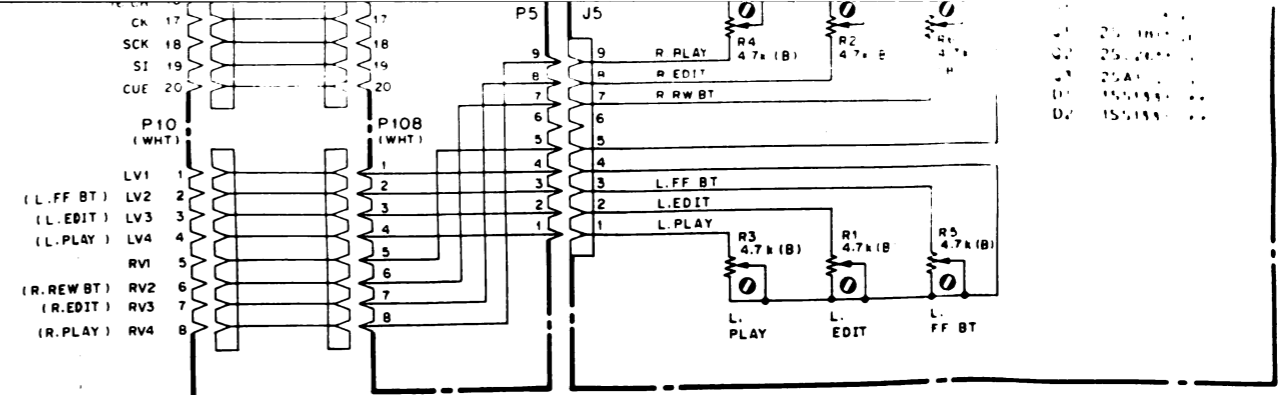

A

B

C

D

E

OPERATION PCB

ACCESSORY

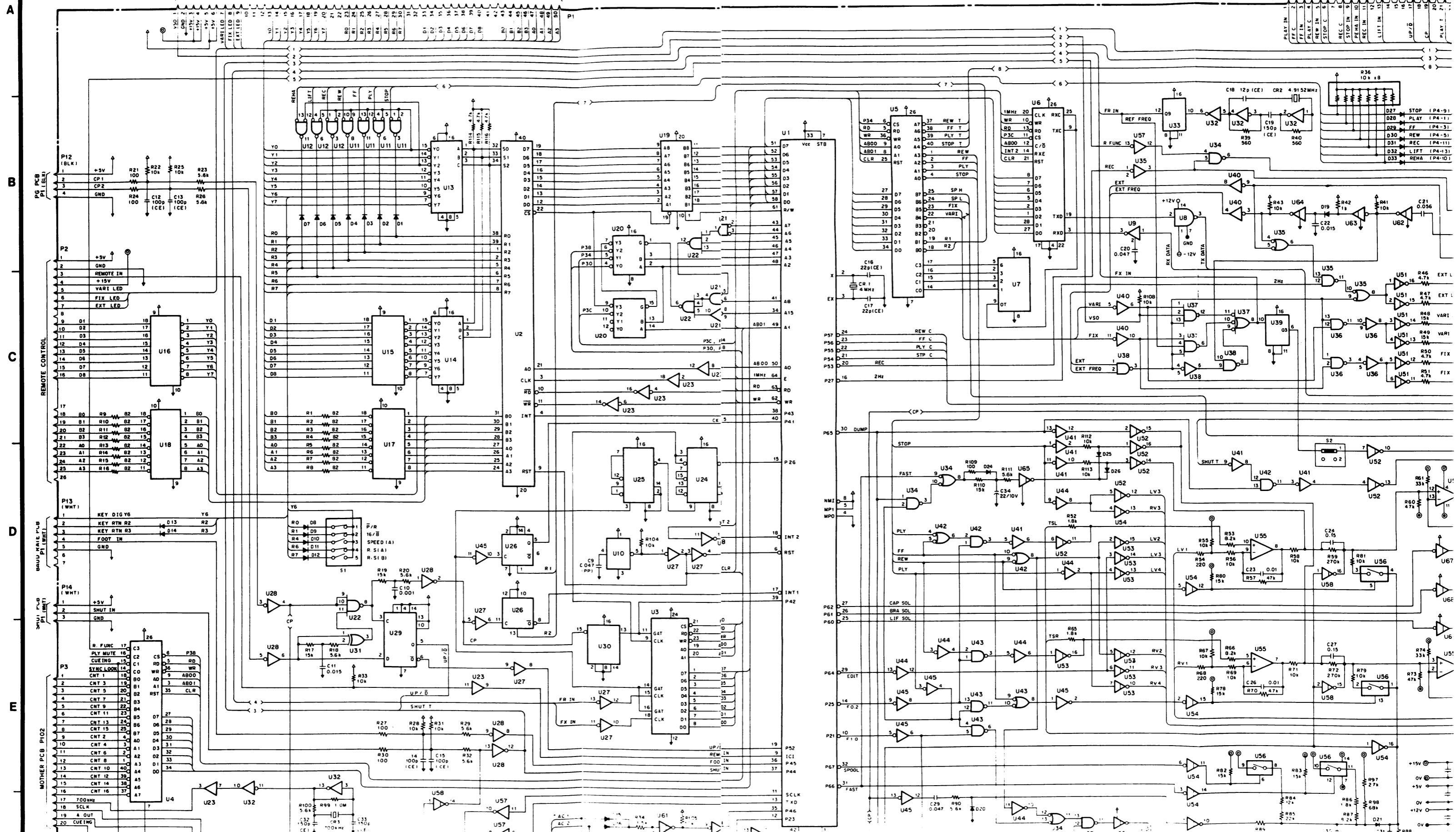

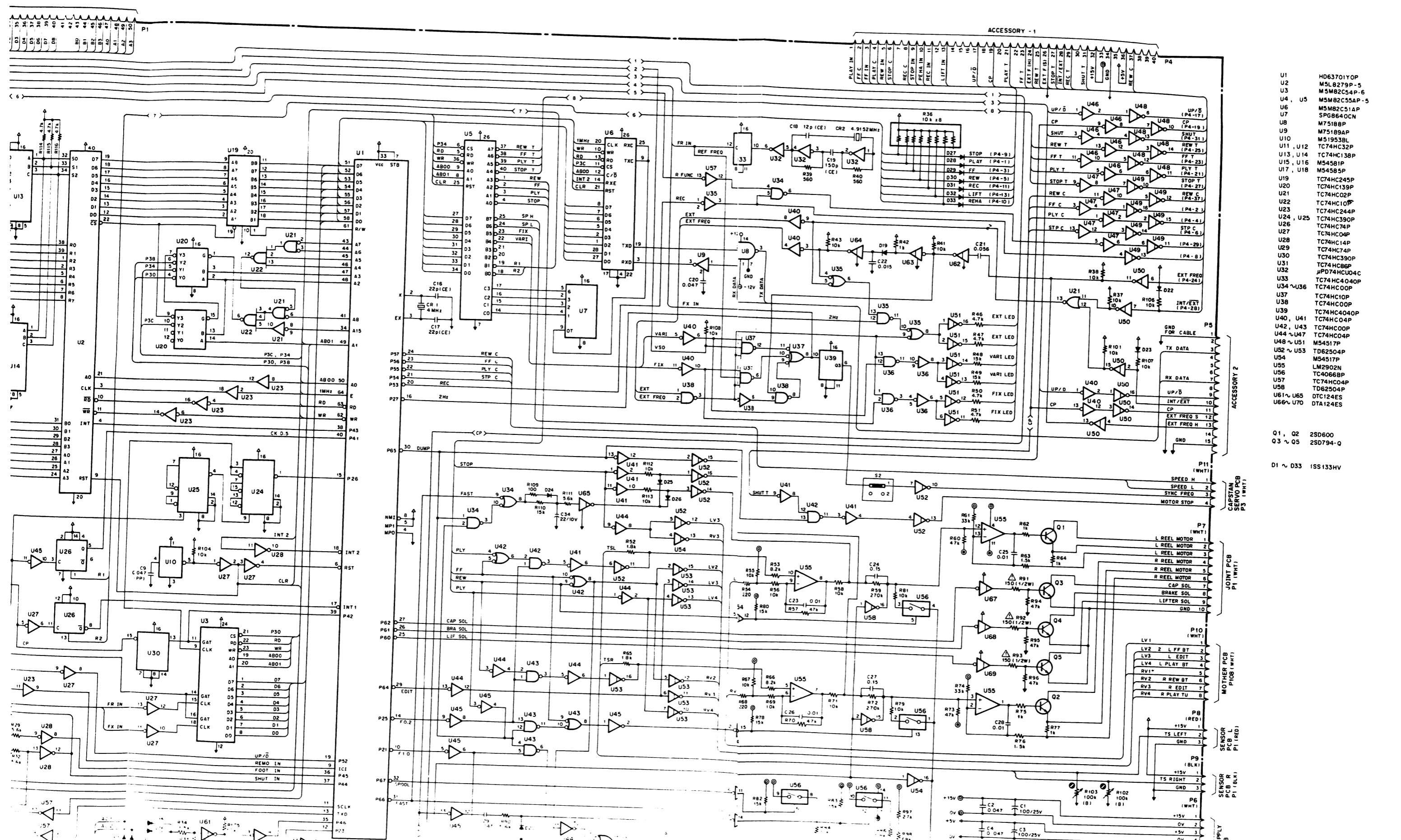

- U1 HD63701YOP
- U2 M5L8279P-5
- U3 M5M82C54P-6
- U4, U5 M5M82C55AP-5
- U6 M5M82C51AP
- U7 SPG8640CN
- U8 M75188P
- U9 M75189AP
- U10 M51953BL
- U11, U12 TC74HC32P
- U13, U14 TC74HC138P
- U15, U16 M54581P
- U17, U18 M54585P
- U19 TC74HC245P
- U20 TC74HC139P
- U21 TC74HC02P
- U22 TC74HC10P
- U23 TC74HC244P
- U24, U25 TC74HC390P
- U26 TC74HC74P
- U27 TC74HC04P
- U28 TC74HC14P
- U29 TC74HC74P
- U30 TC74HC390P
- U31 M74VHC04C
- U32 TC74HC4040P
- U33 TC74HC00P
- U34 ~ U36 TC74HC10P
- U37 TC74HC00P
- U38 TC74HC00P
- U39 TC74HC4040P
- U40, U41 TC74HC04P
- U42, U43 TC74HC00P
- U44 ~ U47 TC74HC04P
- U48 ~ U51 M54517P
- U52 ~ U53 TD62504P
- U54 M54517P
- U55 LM2902N
- U56 TC4066BP
- U57 TC74HC04P
- U58 TD62504P
- U61 ~ U65 DTC124ES
- U66 ~ U70 DTA124ES

- Q1, Q2 2SD600
- Q3 ~ Q5 2SD794-Q
- D1 ~ D33 1SS133HV

ACCESSORY 2

ACCESSORY 1

JOINT PCB

MOTHER PCB

SENSOR PCB

UPPLY

C

D

E

F

G

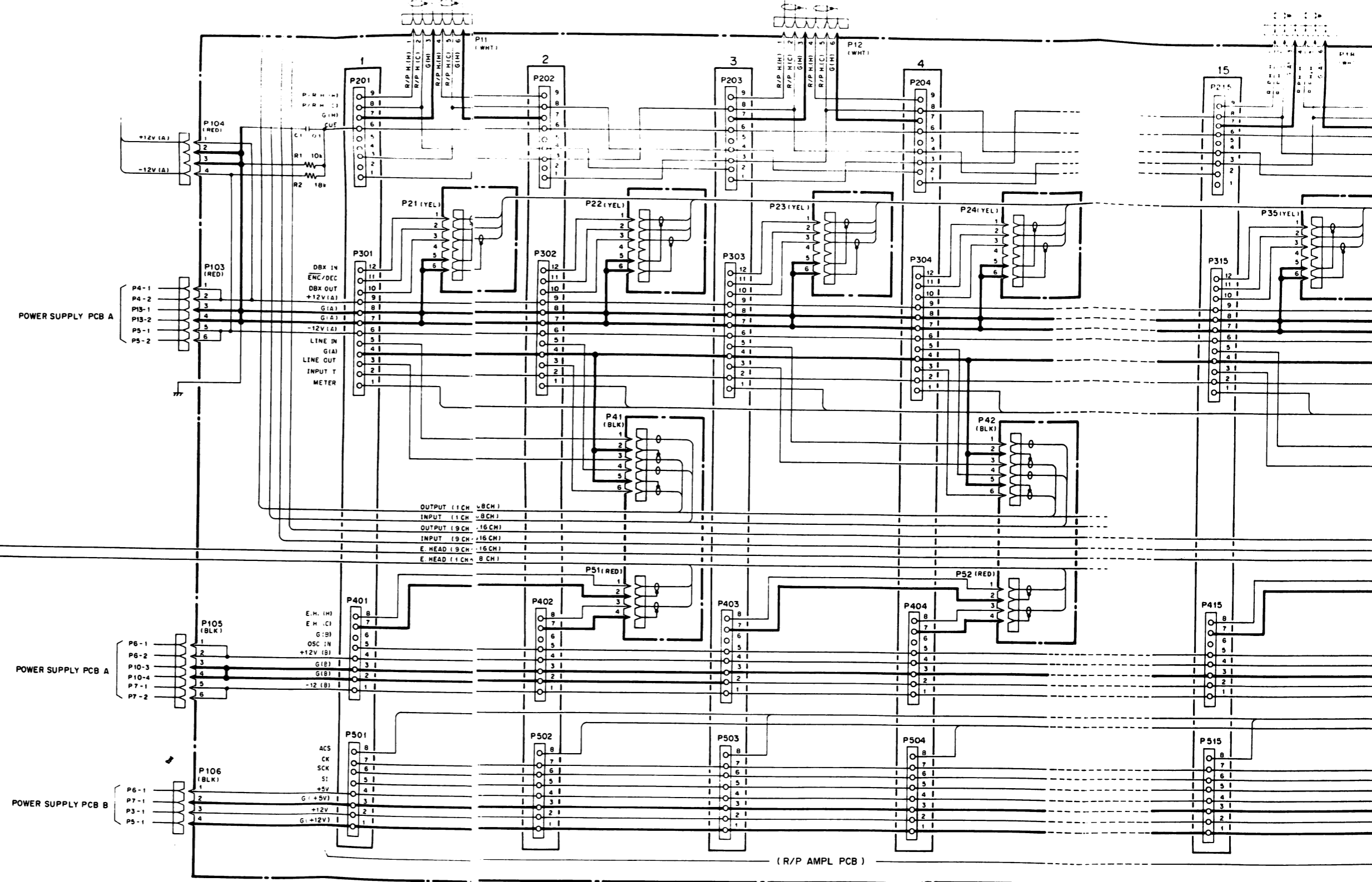
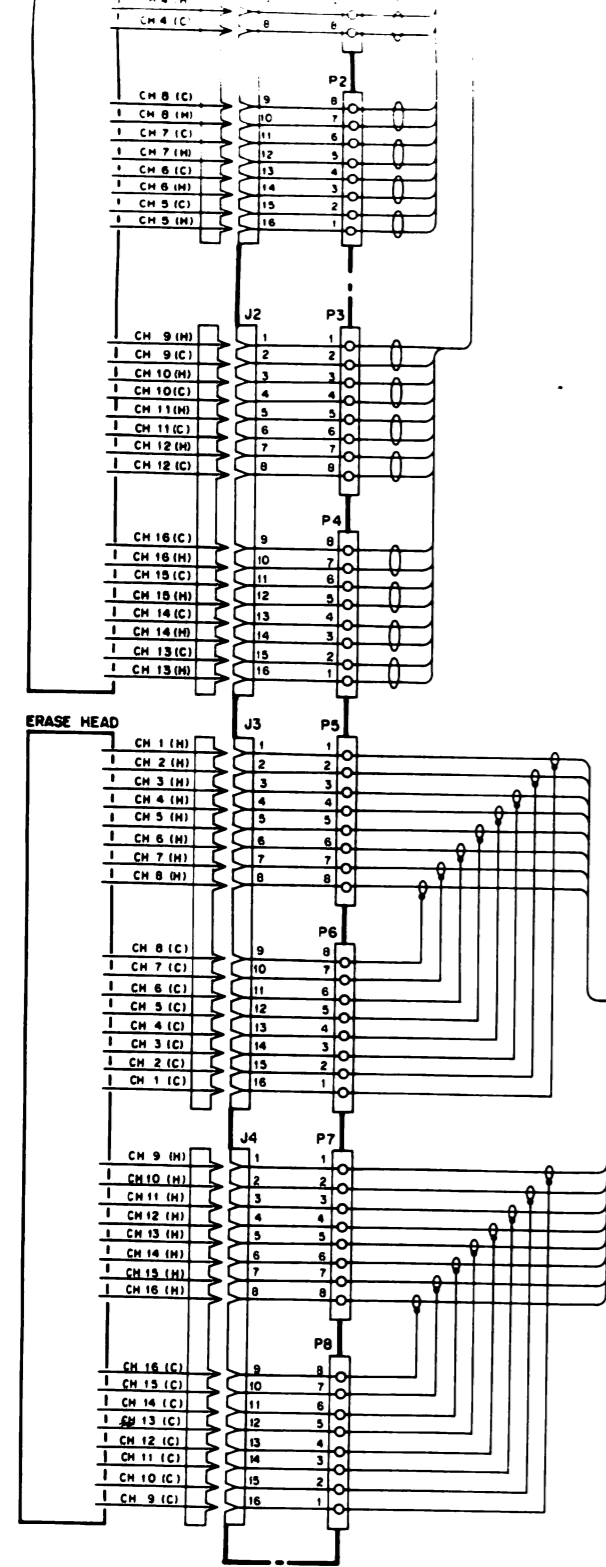

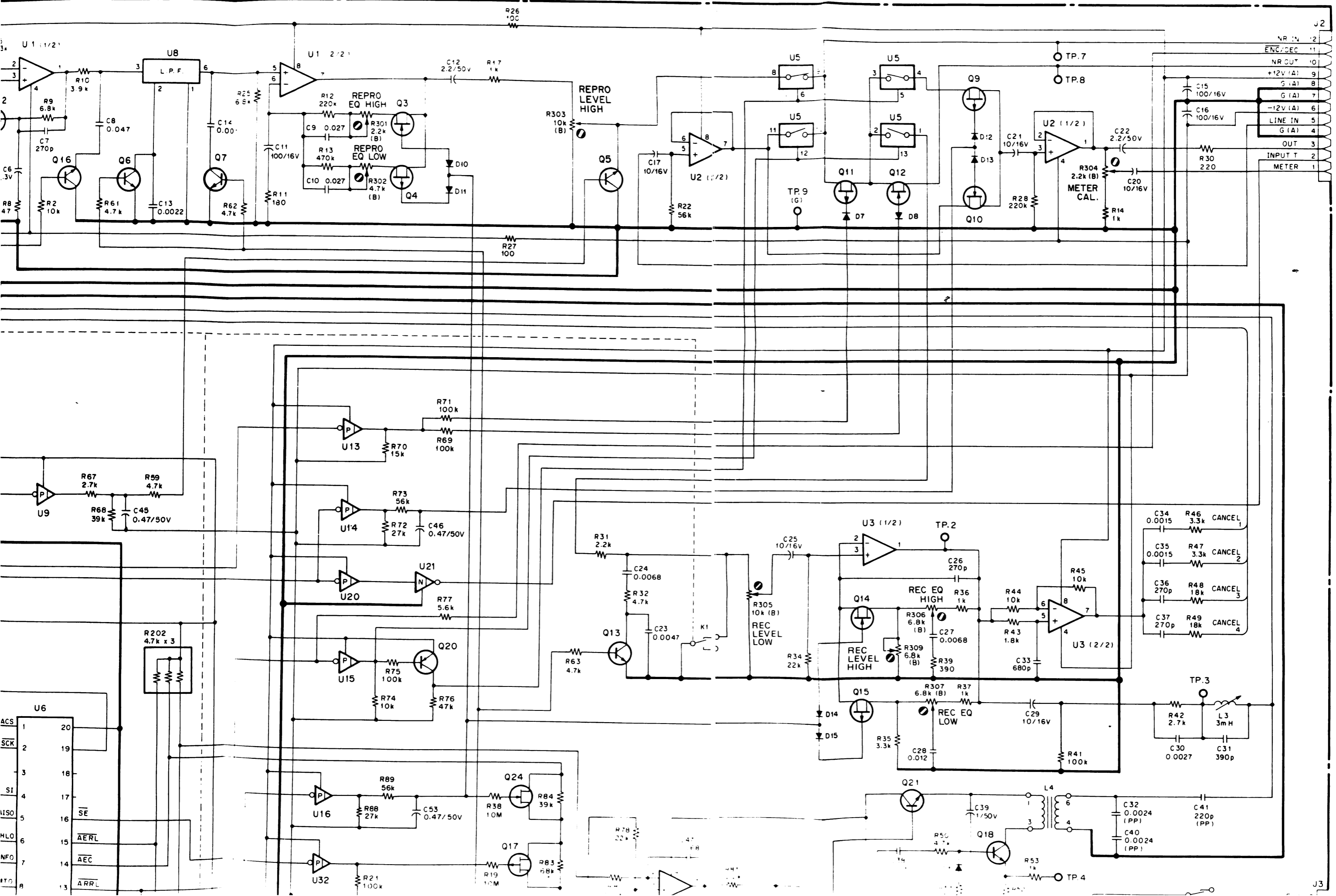

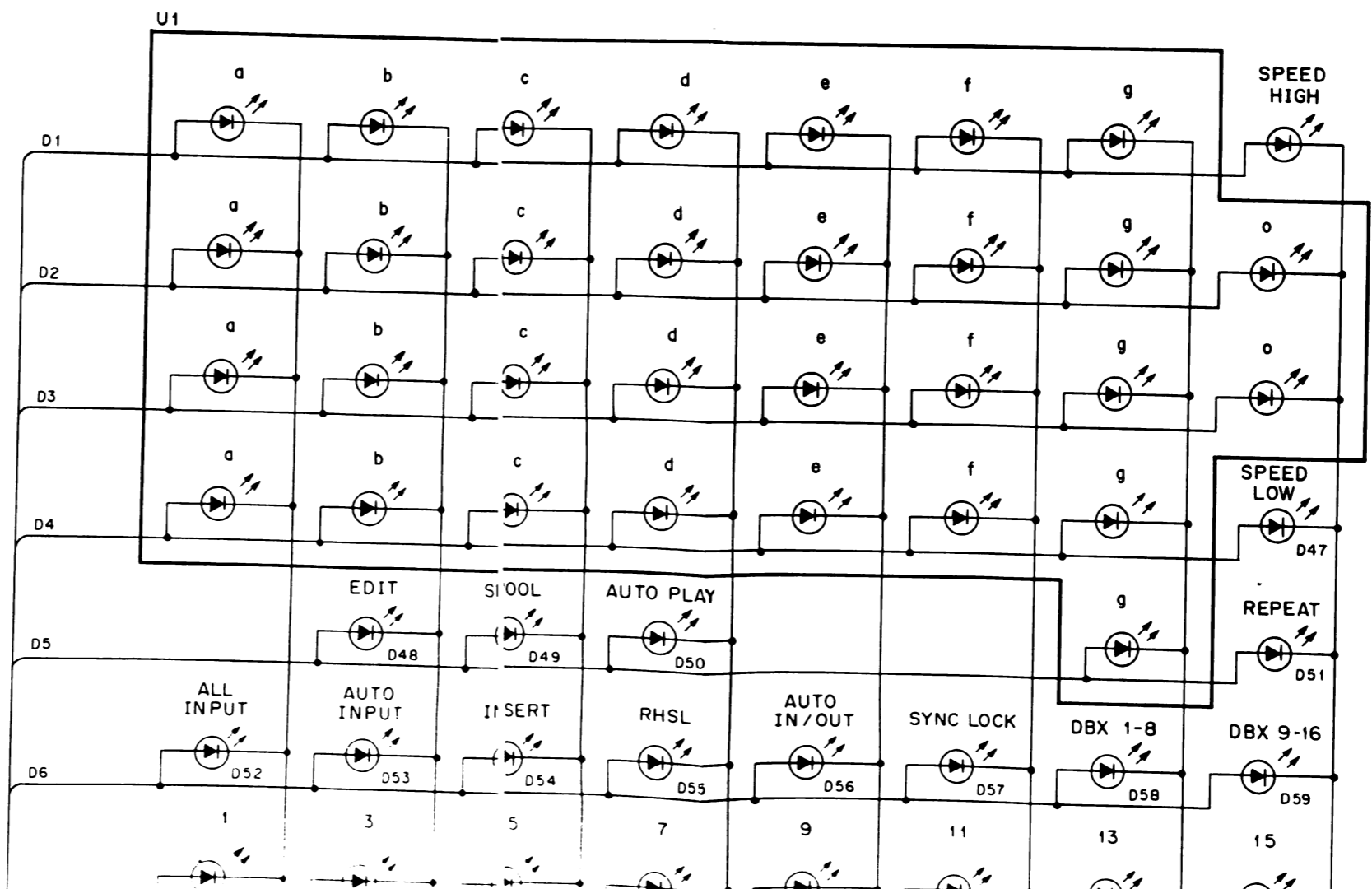
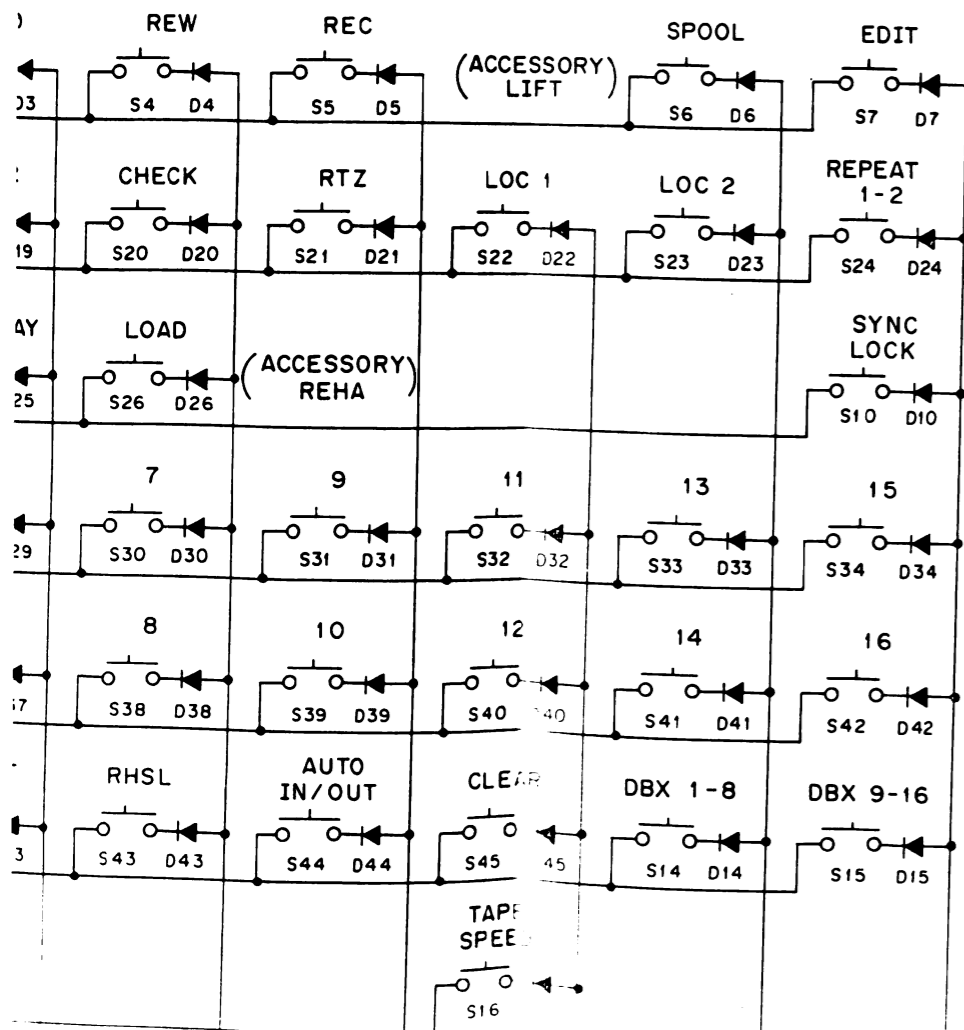
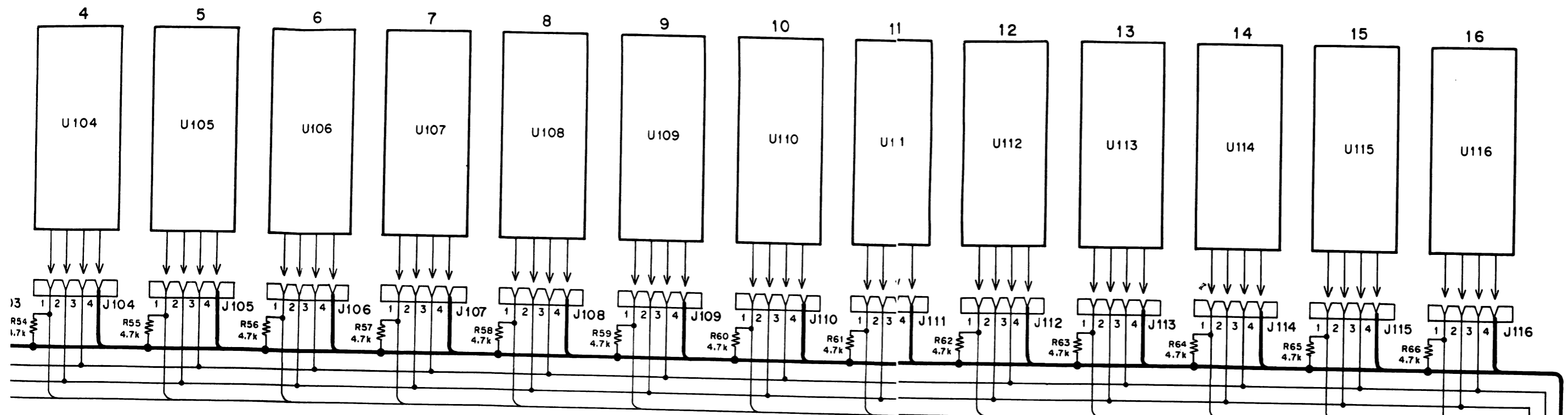

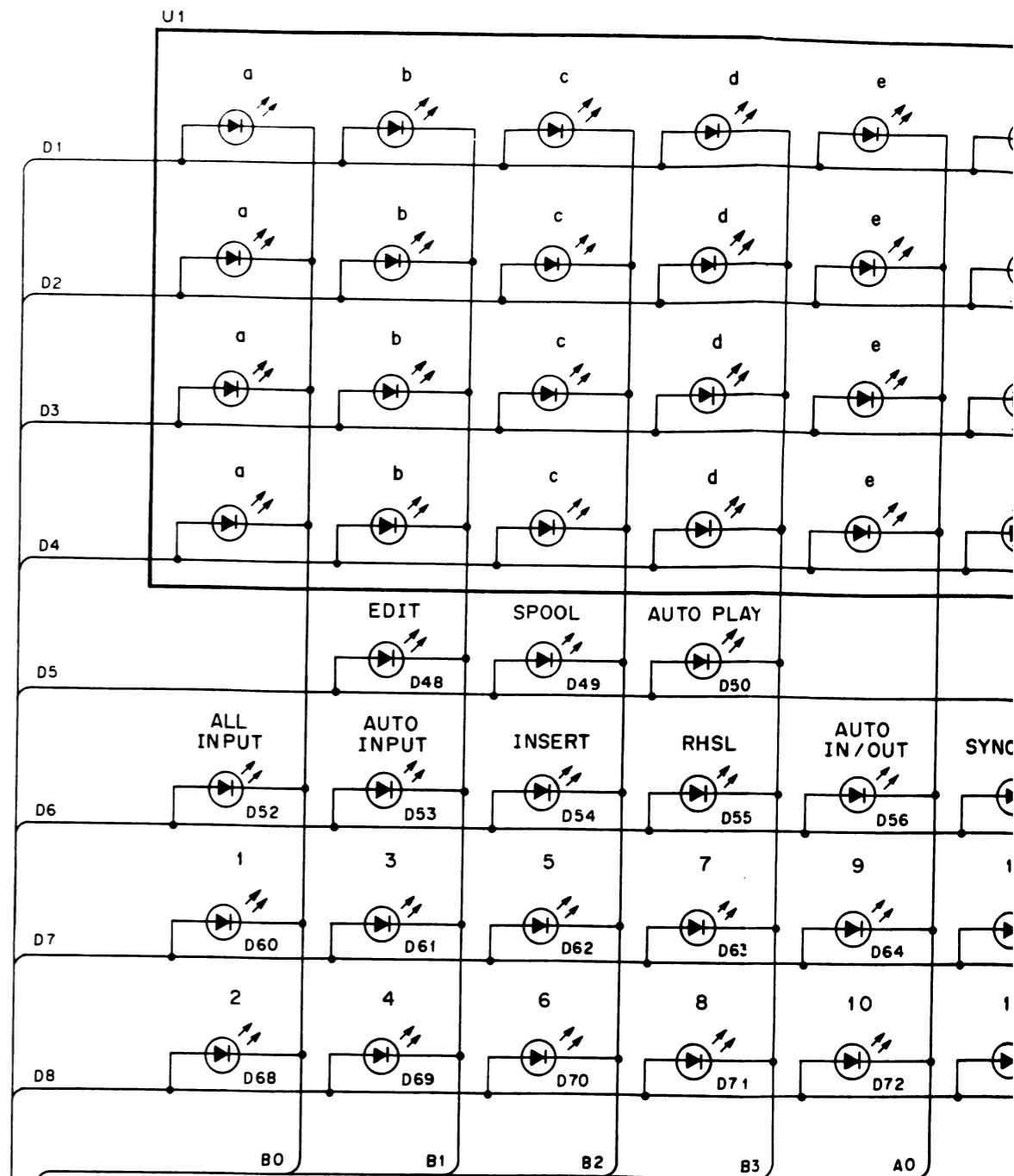
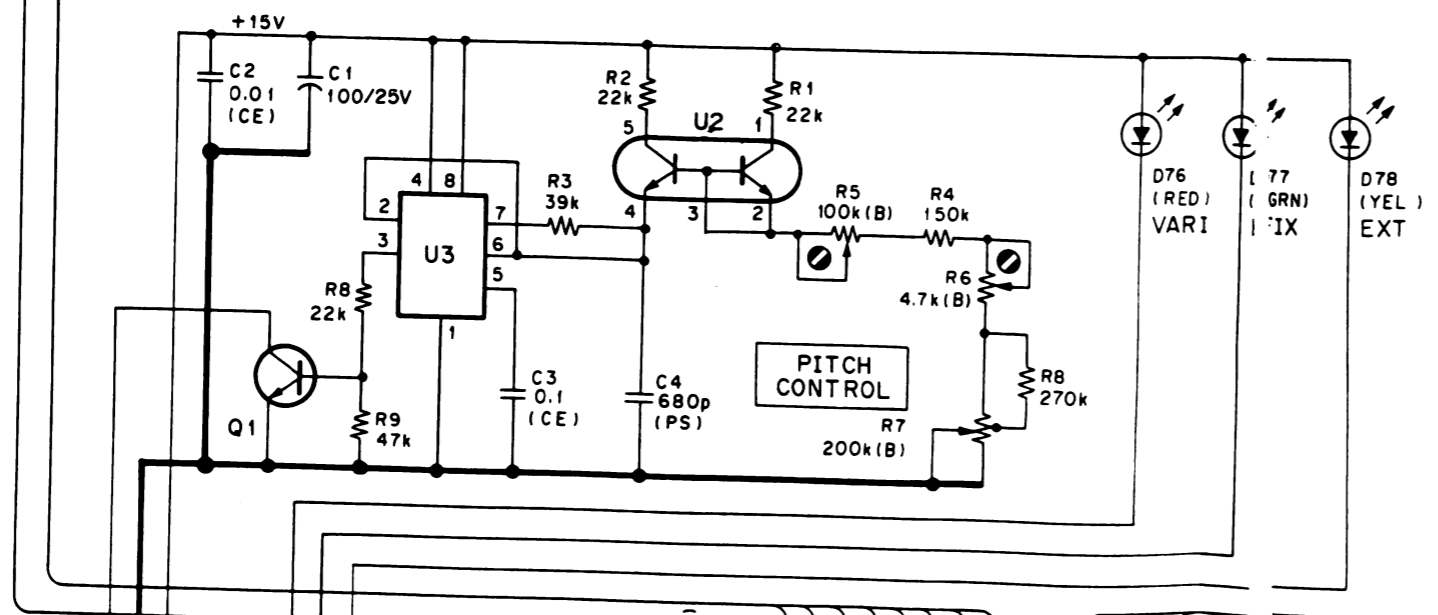
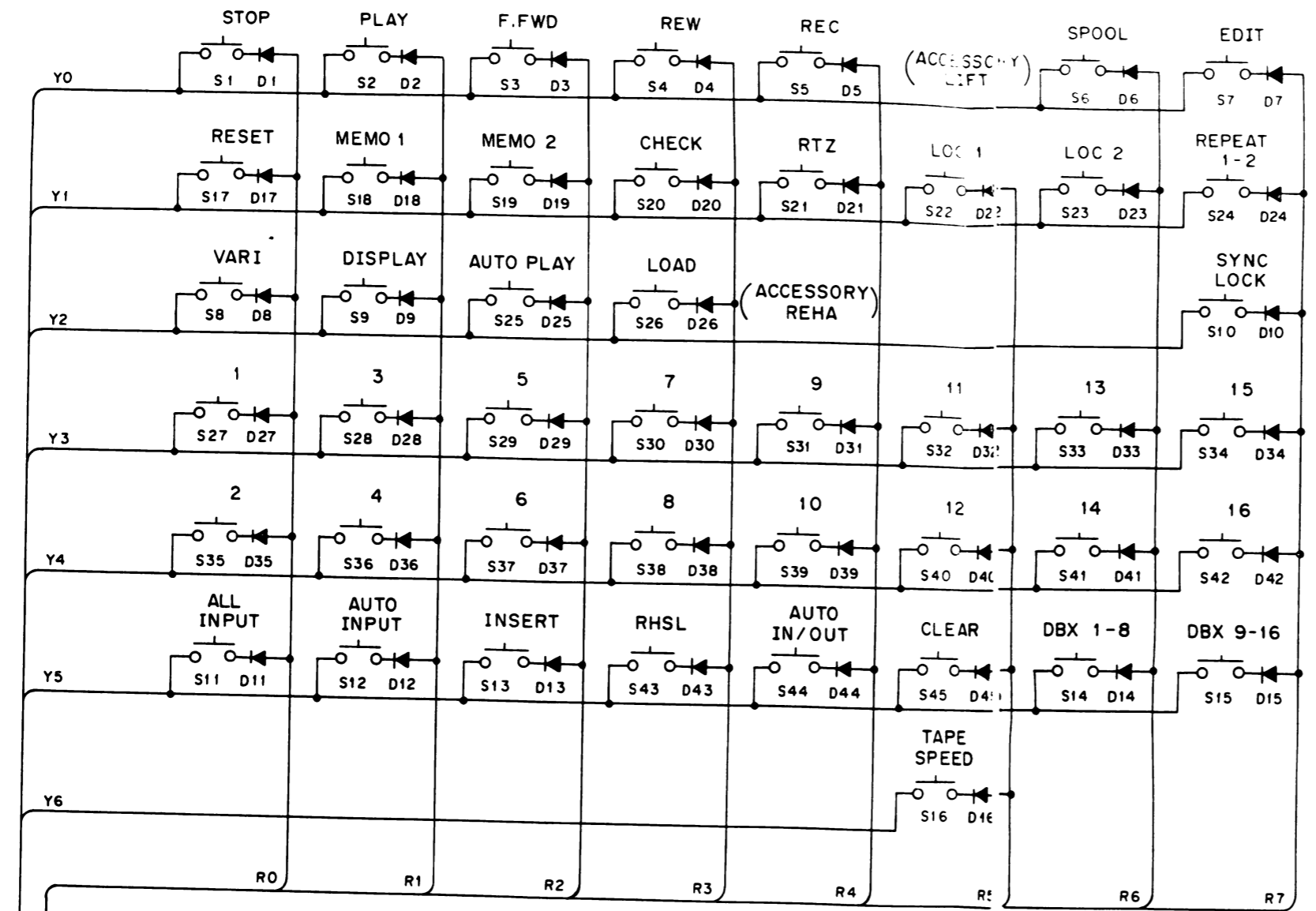

- | | | | |
|-------------|--------------------|-----------|---------------|
| U1 | LED DISPLAY | D1 ~ D45 | 1SS133HV |
| U2 | 2SA995F | D46, D57 | SLP-135 (RED) |
| U3 | MC1455 | D58, D59 | SLP-235 (GRN) |
| U101 ~ U116 | LEVEL METER MODULE | D60 ~ D75 | SLP-135 (RED) |
| Q1 | 2SC1815GR | D76 | SLP-135 (RED) |
| | | D77 | SLP-235 (GRN) |
| | | D78 | SLP-435 (YEL) |

OPERAT

C
D
E
F
G
I