



TDA2822

LINEAR INTEGRATED CIRCUIT

DUAL LOW VOLTAGE POWER AMPLIFIER

DESCRIPTION

The UTC **TDA2822** is a monolithic integrated audio amplifier in a 8-Pin plastic dual in line package. It is designed for portable cassette players and radios.

FEATURES

- * Wide Operating Supply Voltage: $V_{CC}=1.8V - 12V$.
- * Low Crossover Distortion.
- * Low Quiescent Circuit Current.
- * Bridge/Stereo Configuration.

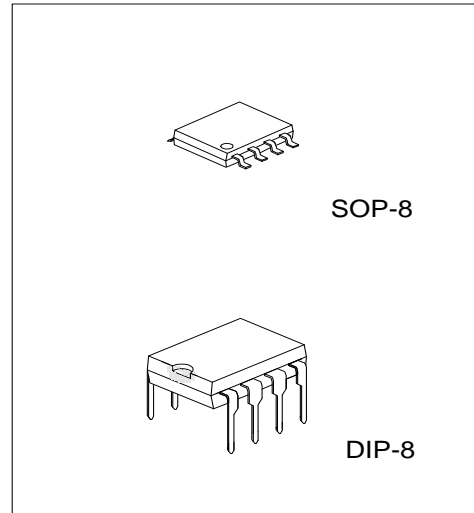

ORDERING INFORMATION

Ordering Number		Package	Packing
Lead Free	Halogen Free		
TDA2822L-S08-R	TDA2822G-S08-R	SOP-8	Tape Reel
TDA2822L-S08-T	TDA2822G-S08-T	SOP-8	Tube
TDA2822L-D08-T	TDA2822G-D08-T	DIP-8	Tube

<p>TDA2822L-D08-T</p> <p>(1) Packing Type (2) Package Type (3) Lead Free</p>	<p>(1) R: Tape Reel, T: Tube (2) D08: DIP-8, S08: SOP-8 (3) G: Halogen Free, L: Lead Free</p>
--	---

■ PIN CONFIGURATIONS

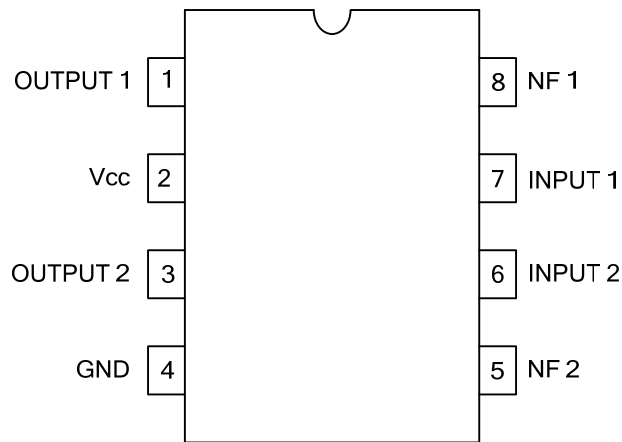

■ BLOCK DIAGRAM

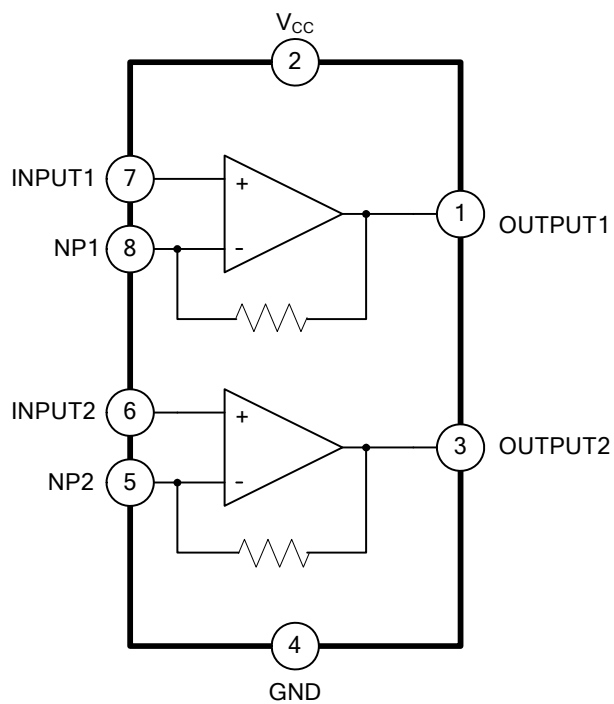

■ ABSOLUTE MAXIMUM RATINGS (T_A=25°C)

PARAMETER	SYMBOL	RATINGS	UNIT
Supply Voltage	V _{CC}	15	V
Output Peak Current	I _{O(PEAK)}	1	A
Power Dissipation	DIP-8	P _D	W
	SOP-8		
Operating Temperature	T _{OPR}	-20~+85	°C
Storage Temperature	T _{STG}	-40~+150	°C

Note:1. Absolute maximum ratings are stress ratings only and functional device operation is not implied. The device could be damaged beyond Absolute maximum ratings.

2. The device is guaranteed to meet performance specifications within 0°C~70°C operating temperature range and assured by design from -20°C~85°C

■ ELECTRICAL CHARACTERISTICS (T_A=25°C, V_{CC}=6V, f=1kHz, unless otherwise specified)

PARAMETER	SYMBOL	TEST CONDITIONS	MIN	TYP	MAX	UNIT	
Operating Supply Voltage	V _{CC}		1.8		12	V	
Quiescent Circuit Current	I _{CC}	V _{IN} =0		9		mA	
Closed Loop Voltage Gain	G _{VC}	Stereo		40		dB	
				40			
Channel Balance	CB	Stereo	-1	0	1	dB	
Output Power(Stereo)	DIP-8	P _{OUT}	V _{CC} =6V, R _L =4Ω, THD=10%	0.4	0.65	W	
	SOP-8			0.28	0.45		
	DIP-8			V _{CC} =3V, R _L =4Ω, THD=10%		0.11	W
	SOP-8					0.07	
Output Power (Bridge)	DIP-8	P _{OUT}	V _{CC} =6V, R _L =4Ω, THD=10%	0.9	1.35	W	
	SOP-8			0.63	0.94		
	DIP-8			V _{CC} =3V, R _L =4Ω, THD=10%		0.35	W
	SOP-8					0.24	
Total Harmonic Distortion	THD	R _L =8Ω, P _{OUT} =0.2W		0.5		%	
				R _L =8Ω, P _{OUT} =0.5W	0.5		%
Ripple Rejection	RR	Stereo, f=100Hz, C3=100μF	24	30		dB	
Output Noise Voltage	e _N	Stereo, BW(-3dB)=20Hz ~20kHz		0.5	2.0	mV	
Cross Talk	C _T	Stereo, f=1kHz		50		dB	
Input Resistance	R _{IN}		100			kΩ	

■ TEST CIRCUIT

STEREO

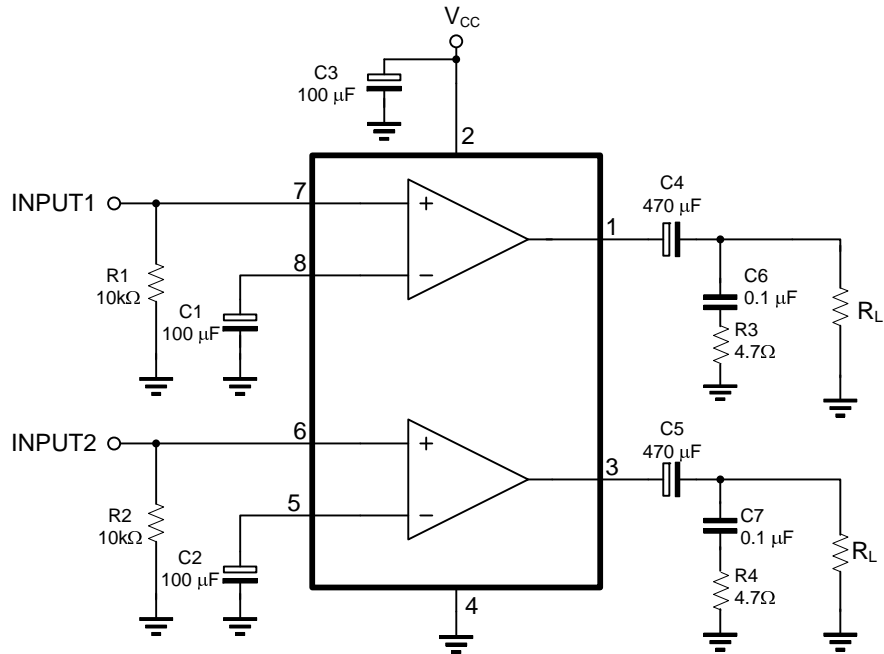

BRIDGE

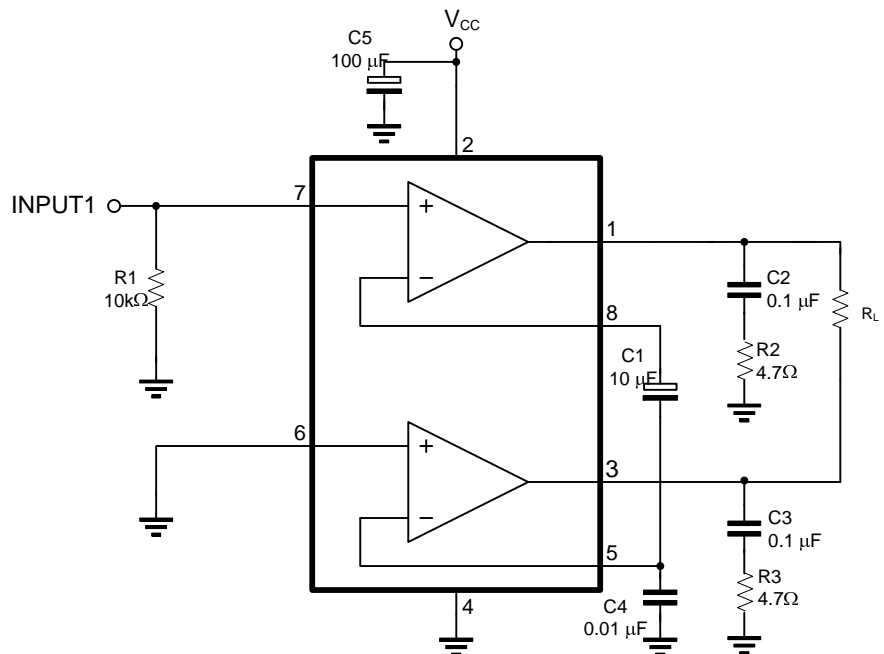

■ SCHEMATIC DIAGRAM

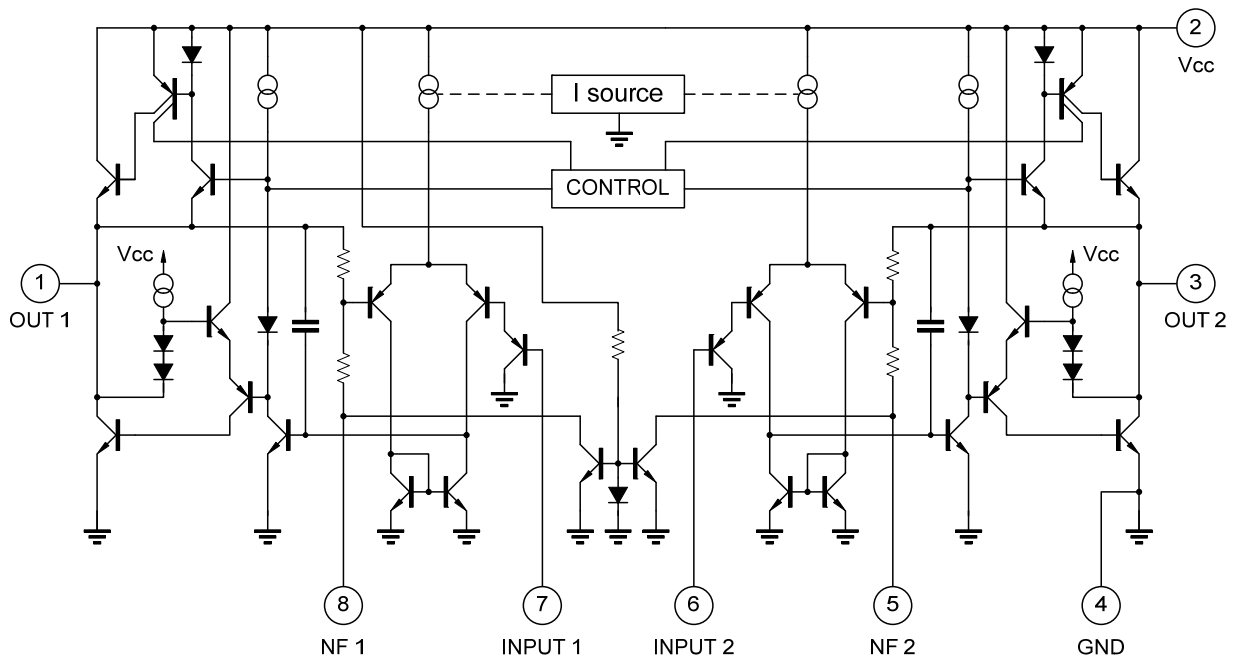

■ TYPICAL CHARACTERISTICS

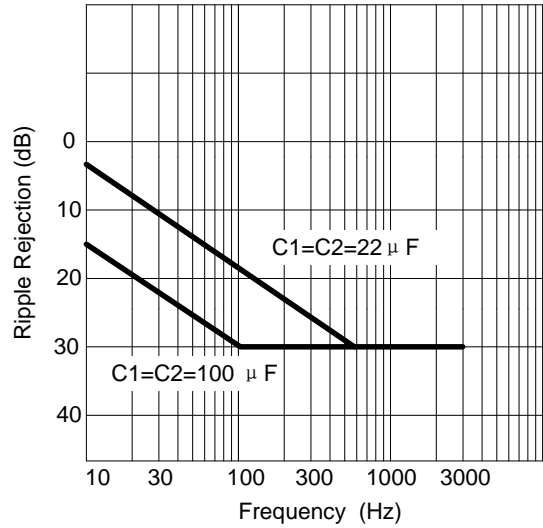
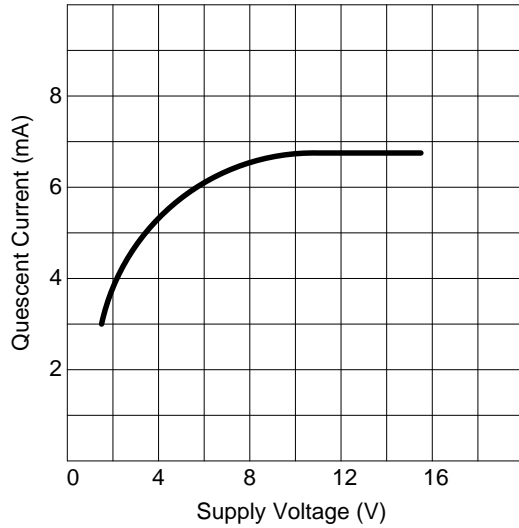

UTC assumes no responsibility for equipment failures that result from using products at values that exceed, even momentarily, rated values (such as maximum ratings, operating condition ranges, or other parameters) listed in products specifications of any and all UTC products described or contained herein. UTC products are not designed for use in life support appliances, devices or systems where malfunction of these products can be reasonably expected to result in personal injury. Reproduction in whole or in part is prohibited without the prior written consent of the copyright owner. The information presented in this document does not form part of any quotation or contract, is believed to be accurate and reliable and may be changed without notice.

www.s-manuals.com