

G4 *Black Magic*

G4 EVO

INSTRUCTION MANUAL

1/10 SCALE 200MM 4WD GAS ON ROAD

TECHNICAL INFORMATION

Length: 365mm

Width: 200mm

Wheelbase: 259mm

Gear Ratio: 1st 6.32:1 / 2nd 4.95:1

Weight: Approx. 1725g

The
of

POWER

Team Magic

www.teammagic.com.tw

SAFETY PRECAUTIONS

- ❖ This radio control model car is not a toy!
- ❖ First time builders should seek the advice of experienced modelers before starting assembly.
- ❖ Assemble this kit only in places out of children's reach!
- ❖ Take enough safety precautions prior to operating this model. You are responsible for this model's assembly and safe operation!

Competition X

A WEB SITE

FOR THE SERIOUS RACER



BEFORE STARTING ASSEMBLY, PLEASE READ THIS INSTRUCTION MANUAL THOROUGHLY.



www.teammagic.com.tw



Thank you for purchasing this Team Magic car. This manual contains steps and instructions you will use to set up your car. Please read the entire manual before starting to assemble your car. Follow the directions in this manual closely to reduce any problems. We hope that you will enjoy your new Team Magic car.

TOOLS SUPPLIED

- ① #116042 Allen Wrenches (1.5mm, 2.0mm, 2.5mm & 5mm)
- ② #116043 Cross Wrench (4mm, 5mm, 5.5mm & 7mm)

YOU WILL NEED THESE TOOLS TO ASSEMBLE YOUR KIT.

- ① #116010 Philips Screw Driver (4mm)
- ② #116026 Philips Screw Driver (5.8mm)
- ③ #116009 Slotted Screw Driver (4mm)
- ④ Needlenose Pliers
- ⑤ Thread Locking Adhesive
- ⑥ Super Glue
- ⑦ Hobby Knife
- ⑧ Precision Ruler
- ⑨ Calipers

READ THIS BEFORE BUILDING

This manual is for the G4 kit & will help you assemble and set up the car. Read the manual to the end before assembling your kit and before contacting us for help.

OPEN THE BAGS IN ORDER

The assembly is arranged so that you will open and finish that bag before you go on to the next bag. Sometimes you will have parts remaining at the end of a bag. These will become part of the following bags. Some bags may have a large amount of small parts. To make it easier to find the parts, we recommend using a partitioned box for allocating the parts so they can be easily found.

SUPPLEMENTAL SHEETS

We are constantly updating parts to improve our kits. These changes, if any, will be noted in supplementary sheets located inside the kit box. When a supplement sheet is found, attach it to the appropriate section of the manual.

MANUAL FORMAT

The following explains the format of these instructions. The beginning of each section indicated:

- ① Which bag to open (BAG A).
- ② Which parts you will use for those steps. Remove only the parts shown. "1:1" indicates an actual size drawing. Place your part on top of the drawing and compare it so it does not get confused with a similar part.
- ③ The instructions in each step are ordered in the order you complete them, so read the words & follow the pictures. The numbers in circles are also in the drawing to help you locate them faster.

The manual that comes with your Team Magic G4 is complete. However, as development is a continuous process, up-to-date information about the G4 is provided on our web site: www.teammagic.com.tw

Here you will find the very latest information about your G4: reports by team racers and other experts with the latest tips and tricks, FAQ, forums, set-ups & download files. So make sure to visit Team Magic web site frequently.

CONTACT US

Team Magic Model Industrial Co. Ltd.
No. 185-2, 38th Road, Taichung Industrial Park, Taichung, Taiwan 407
Tel: 886-4-23552606
Fax: 886-4-23552946
E-Mail: service@teammagic.com.tw
Web Site: www.teammagic.com.tw

BAG A



502101, qty 2
2 Speed Shoe
Cam Post



502103, qty 2
2 Speed Shoe
Spring



150610, qty 2
6x10x3mm Bearing

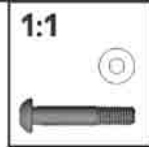

502103, qty 2
2 Speed Shoe
Screw



502110, qty 1
2 Speed Housing
Nut



502111, qty 1
One Way Hub
Nut (w/notch)



502101, qty 1
2 Speed Shoe Cam



502105, qty 1
2nd 47T Spur
Gear



502110, qty 1
2 Speed Housing



502108, qty 1
1st 51T Spur Gear



502111, qty 1
One Way Hub



502102, qty 2
2 Speed Shoe

STEP 1

Two Speed Shoe Assembly

- 1 Insert #502101 2 speed shoe cam posts into #502102 two speed shoes.
- 2 Take the two shoes and sandwich the #502101 2 speed shoe cam.
- 3 Slide #502103 springs onto screws. Insert the screw and spring into the 2 speed shoes and tighten the screws. The screws should be flush with the edge as shown.

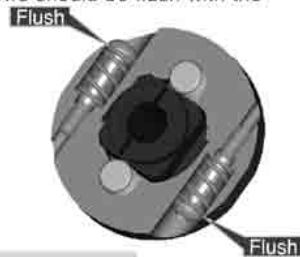

A good starting point is to have the screw flush with the edge.
 ⚠️ Screw in both adjusting screws if you want it to shift later.
 Screw out both adjusting screws to shift earlier. **PLEASE REFER TO FINAL ADJUSTMENTS - TWO SPEED.**

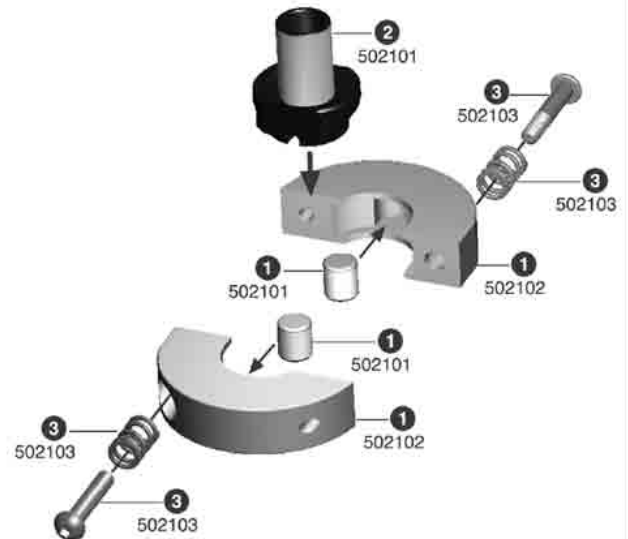

STEP 2

Two Speed Housing Assembly

- 1 Attach #502105 47T spur gear to #502110 clutch housing with #502110 clutch housing nut. Make sure the spur gear is aligned with the clutch housing.
- 2 Insert one #150610 6x10x3mm ball bearing in each side.

Not Flush

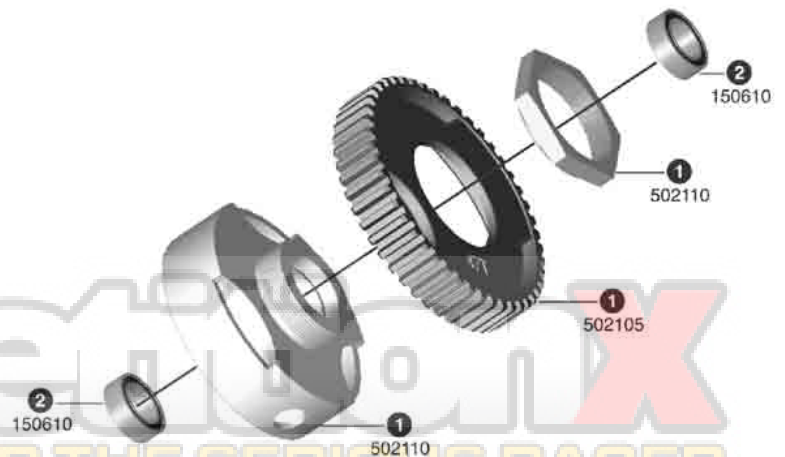

⚠️ It is correct the outside bearing isn't flush with the edge of the 2 speed housing as shown.

STEP 3

One Way Hub Assembly

1 Attach #502108 51T spur gear to #502111 one way hub with #502111 one way hub nut. This nut is the one with notch on its side. The thread is counter clockwise. Make sure the spur gear is aligned with the gear.

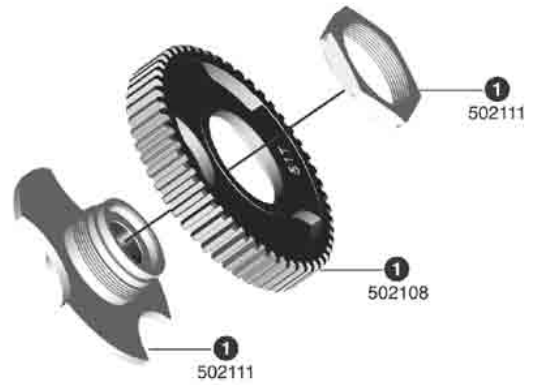















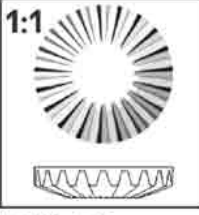

Optional Parts

- | | |
|--------------------------------------|--------------------------------------|
| 502104▶ G4 2 Speed 2nd Spur Gear 46T | 502107▶ G4 2 Speed 1st Spur Gear 50T |
| 502105▶ G4 2 Speed 2nd Spur Gear 47T | 502108▶ G4 2 Speed 1st Spur Gear 51T |
| 502106▶ G4 2 Speed 2nd Spur Gear 48T | 502109▶ G4 2 Speed 1st Spur Gear 52T |



BAG B

 1:1 502122, qty 4 3x10mm Cross RH TP screw 61	 502116, qty 2 Diff. Joint 62	 1:1 502117, qty 4 4x10mm Shim 63	 1:1 502116, qty 2 5x12mm Shim 65	 1:1 502116, qty 2 P5 O-ring 64	 1:1 502116, qty 2 2x11mm Pin 66	 1:1 151218, qty 4 12x18x4 Bearing 63
 1:1 502117, qty 2 4x27mm Diff Bevel Gear Shaft 68	 1:1 502117, qty 4 Small Diff Bevel Gear 69	 1:1 502117, qty 2 Large Diff Bevel Gear 67	 502120, qty 1 32T Nylon Front Pulley Gear 61	 502120, qty 1 32T Nylon Front Pulley Lid 61	 502118, qty 1 Diff Case Gasket 61A	
 502122, qty 1 Nylon Rear Pulley 61	 502115, qty 1 Diff Case 61	 502124, qty 1 #30000 Silicone Oil 61B	 502125, qty 1 #600 Silicone Oil (White Body) 61B	 K1409, qty 1 Front One-Way 61B		

STEP 1

Diff Case Assembly

- 1 Place one #151218 12x18x4mm bearing over one #502115 diff case.
- 2 Use a drop of silicone oil on the #502116 diff joint. Slide a #502116 diff joint into the diff case.
- 3 Use a drop of silicone oil on the #502116 O-ring then install the O-ring & 5x12mm shim into the joint.
- 4 Insert #502116 2x11mm pin through the hole in the diff joint.
- 5 Install #502117 large diff bevel gear onto the diff joint. Make sure the pin aligns perfectly with the slot in the gear.
- 6 Slide one #502117 small diff bevel gear onto #502117 bevel gear shaft, followed by one #502117 4x10mm shim. Repeat this step for the other side of this shaft & the other shaft. Please pay close attention to the small bevel gear direction.
- 7 Slide the shaft assembly into the diff case. It doesn't matter which slot you use. Then, insert the second shaft assembly 90 degrees to the first shaft assembly. There are 2 flats on each shaft. Please make the two shafts interlock (flat to flat).

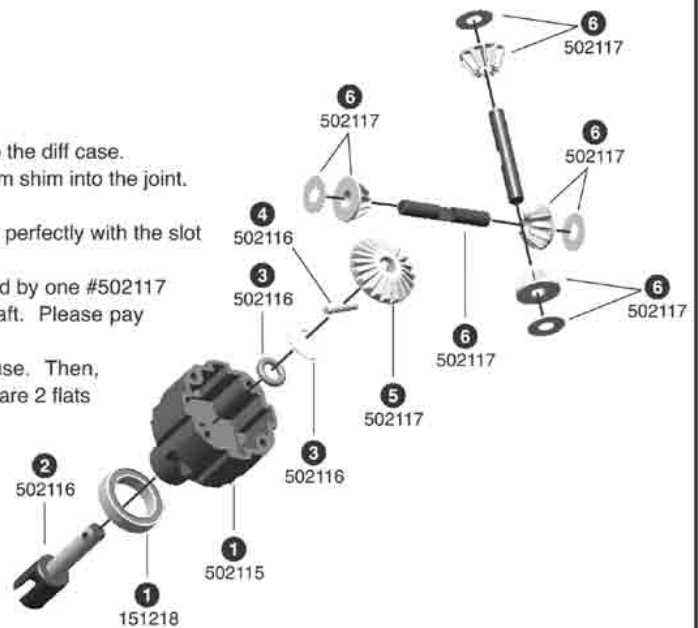

STEP 2

Front One Way Assembly

- 1 PLEASE READ K FACTORY MANUAL FIRST. Add a small drop of CA to the #502120 front pulley lid, spread equally as shown. Attach #502120 32T pulley to the #K1409 front one way with 4pcs #K1409 screws.
- 2 Place a #K1409 alum. ring & a #151218 12x18x4mm bearing on both side of the front one way.
- 3 Slide a #K1409 one way joints on both side of the front one way.

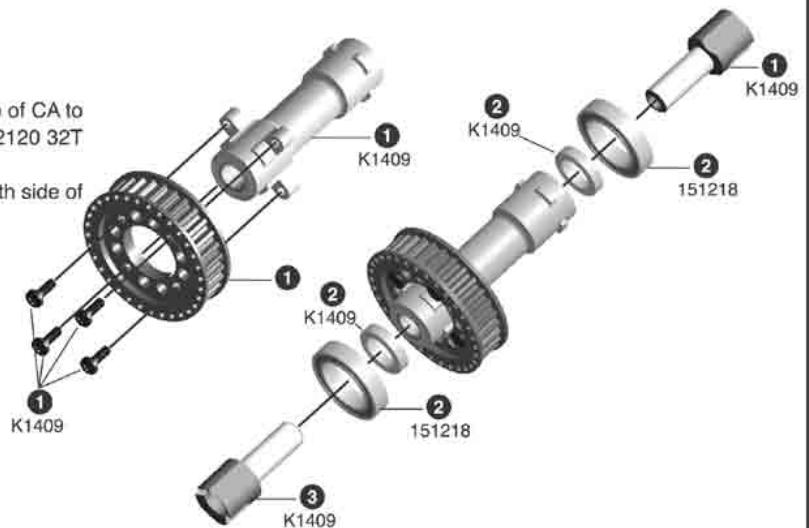

STEP 3

Fill Silicone Oil

- 1 To complete the rear diff assembly, find the #502124 #30000 silicone oil and the #502125 #600 silicone oil. Holding the diff case upright, fill with 50% thick & 50% thin silicone oil to the top of the case.



STEP 4

Rear Diff Assembly

- 1 Use a drop of silicone oil on the #502116 diff joint. Slide a #502116 diff joint into the diff case.
- 2 Use a drop of silicone oil on the #502116 O-ring then install the O-ring & 5x12mm shim into the joint.
- 3 Insert #502116 2x11mm pin through the hole in the diff joint. Make sure it is evenly spaced on both sides of the diff joint.
- 4 Place a #502118 gasket in the nylon rear pulley & make sure the gasket is aligned.
- 5 Place #502117 large diff bevel gear and then the rear pulley assembly on the diff case assembly. Then, tighten with #502122 3x10mm cross BH TP screws.

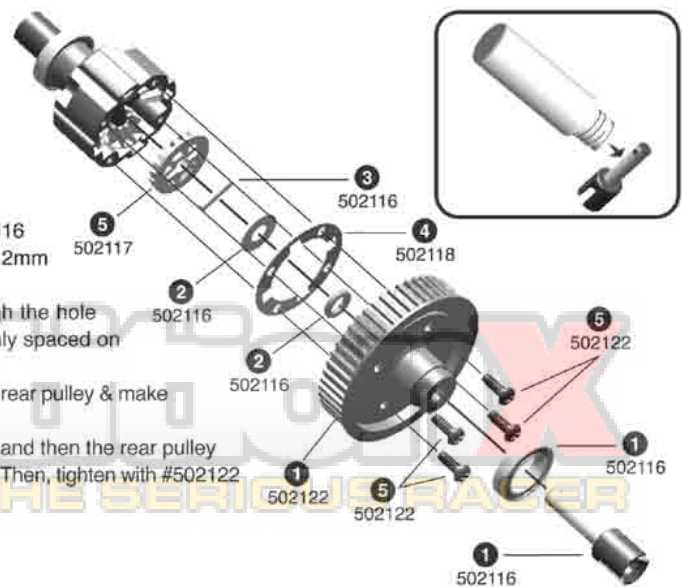

BAG C

 502127, qty 4 Shock Cap Ball End (C1)	 502129, qty 4 G-clip (C2)	 502129, qty 8 P3 O-ring (C2)	 502129, qty 8 Shock Body Washer (C2)	 502130, qty 4 Shock Piston Washer (C2)	 502130, qty 4 Shock Piston E-clip (C2)	 115001, qty 4 Flanged Steel Ball (C3)	 502134, qty 4 Shock Spring Cup (C4)	 502128, qty 4 Shock Collar (C1)
 115022, qty 4 Shock Ball Cup (C4)	 502130, qty 4 Shock Piston (C2)	 502130, qty 4 Shock Shaft (C3)	 502131, qty 4 Membrane (C5)	 502127, qty 4 Shock Cap O-Ring (C5)	 502128, qty 4 Shock Collar O-Ring (C5)			
 502128, qty 4 Hard Coated Threaded Shock Body (C1)	 502127, qty 4 Shock Cap (C1)	 502144, qty 4 Shock Spring (C1)	 502125, qty 1 #600 Silicone Oil (White Body) (C3)					

STEP 1

Shock Body Assembly

- Insert #502129 P3 O-ring, washer, P3 O-ring, washer into #502128 shock body & fasten with #502129 G-clip. Slide the G-clip into the groove in the bottom of the shock body. Make sure it is well seated. Place a couple drops of oil on the O-rings. Install #502127 P10 O-ring on the shock body.
- On the #502130 shock shaft, install a #502130 shock piston washer & followed by a shock piston, then slide #502130 E-clip into the groove. Add a drop of silicone oil on the shock shaft threads. Insert the shock shaft assembly into the shock body.
- Slide #502127 shock cap ball end into shock cap.
- Install #502131 membrane in the top of the shock cap assembly.
- Push the #115001 flanged ball & #502127 shock cap ball end together.

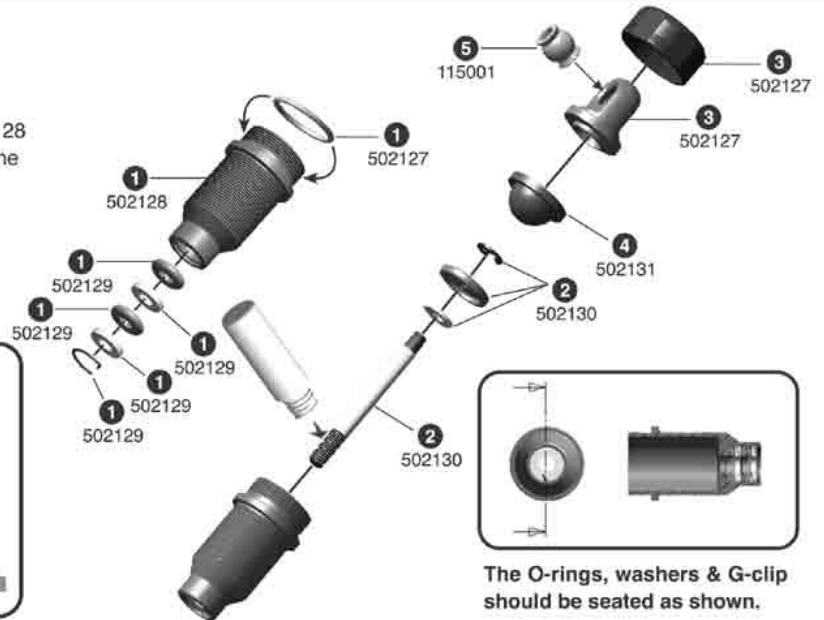
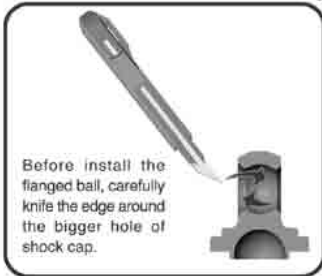

STEP 2

Fill Silicone Oil

- Holding the shock upright, fill with #502125 #600 shock silicone oil to the top of the body.
- Slowly move the shaft up & down several times. Let the oil settle and allow the air to escape.
- Refill with oil to the top of the body.
- Install the shock cap assembly onto the shock body assembly.



STEP 3

Complete The Shock Assembly

- 1 Hold the shaft with a rag and needlenose pliers next to threads, turn the #115022 shock ball cup onto the end of the shock shaft. Don't damage the shock shaft.
- 2 Slide a #502128 shock collar O-ring into the groove in the shock collar. Put one drop of oil on the O-ring before you thread on the shock collar. Thread on the shock collar. Make sure that the shoulder is facing down.
- 3 Slide a #502144 shock spring on the shock. Compress the spring to add a #502134 spring cup to the shock.
- 4 Please repeat the above steps for the remaining 3 shocks.

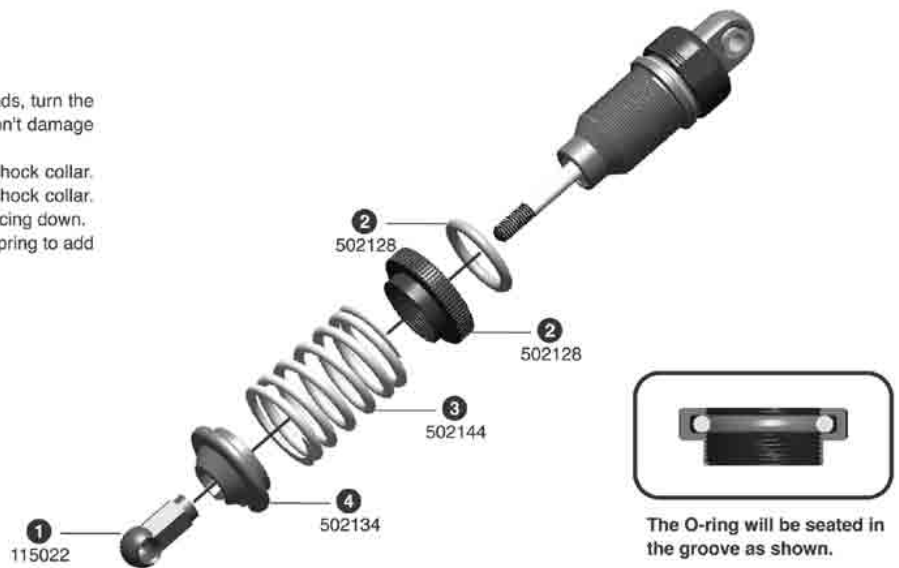

The O-ring will be seated in the groove as shown.

Optional Parts

502135 Shock Spring 1.2mm
502136 Shock Spring 1.3mm
502137 Shock Spring 1.4mm

502138 Shock Spring 1.5mm
502139 Shock Spring 1.6mm
502140 Shock Spring 1.7mm (Silver)

502141 Shock Spring 1.8mm
502142 Shock Spring 1.9mm
502143 Shock Spring Set (8 pairs)



BAG D



115002, qty 2
4mm Ball Stud

03

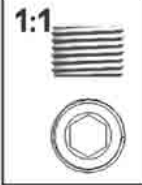

502152, qty 8
Pivot Ball Nut

04



150612, qty 4
6x12x4mm Bearing

05



151015, qty 4
10x15x4mm Bearing

06

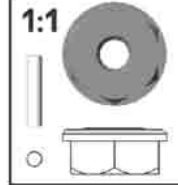

K1418, qty 4
Hex Wheel Adapter

08



115021, qty 2
4.8mm Ball Stud

09



502151, qty 8
9mm Low Friction
Pivot Ball

02



502153, qty 2
Wheel Axle

07



502150, qty 1
Steering Block L

01



502150, qty 1
Steering Block R

01



502155, qty 1
Rear Hub Carrier R

01



502155, qty 1
Rear Hub Carrier L

01



K1462, qty 2
Universal Joint

07

STEP 1

Left Steering Block Pivot Ball Assembly

- 1 Insert #502151 pivot balls into #502150 left steering block & secure them with #502152 pivot ball nuts. The pivot ball should move freely without any binding or excess play.
- 2 Thread a #115002 4mm ball stud into the first hole of the steering block.

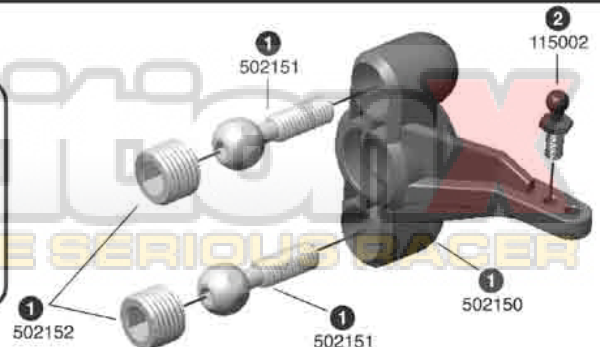
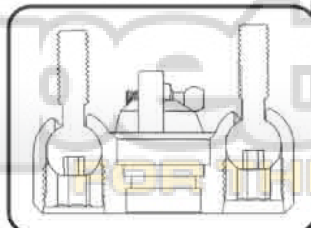

6

STEP 2

Right Steering Block Pivot Ball Assembly

- 1 Insert #502151 pivot balls into #502150 right steering block & secure them with #502152 pivot ball nuts. The pivot ball should move freely without any binding or excess play.
- 2 Thread a #115002 4mm ball stud into the first hole of the steering block.

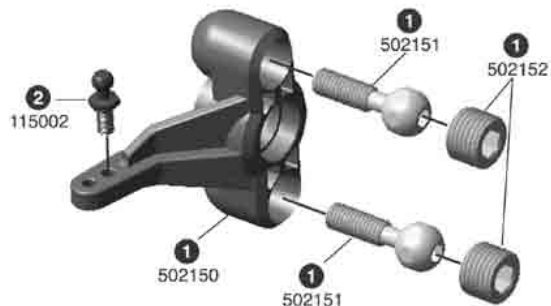

STEP 3

Steering Block Assembly

- 1 Slide a #151015 10x15x4mm & a #150612 6x12x4mm bearing into the #502150 steering block.
- 2 Slide #K1462 universal joint & washer into the steering block assembly.
- 3 Slide in #K1418 2x11mm pin through the universal joint. Slide the #K1418 alum. hex wheel adapter over the universal joint & fasten the pin with the cap screw.

- 4 Repeat these steps for the right steering block assembly.

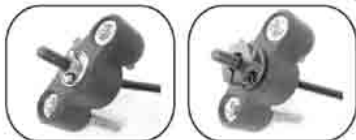
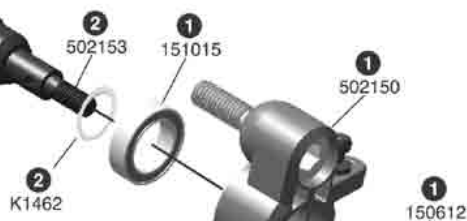

STEP 4

Left Hub Carrier Pivot Ball Assembly

- 1 Insert #502151 pivot balls into #502155 left hub carrier & secure them with #502152 pivot ball nuts. The pivot ball should move freely without any binding or excess play.
- 2 Thread a #115021 4.8mm ball stud into the top hole of the hub carrier.

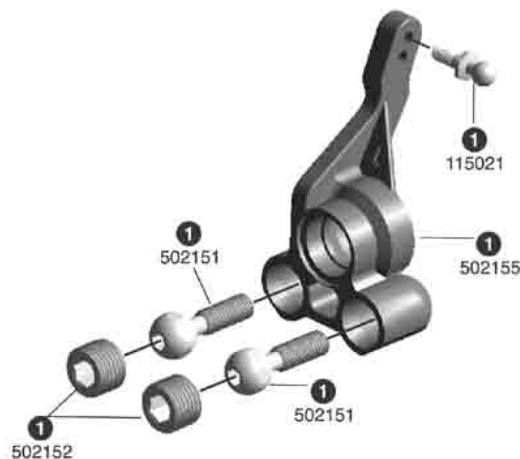

STEP 5

Right Hub Carrier Pivot Ball Assembly

- 1 Insert #502151 pivot balls into #502155 right hub carrier & secure them with #502152 pivot ball nuts. The pivot ball should move freely without any binding or excess play.
- 2 Thread a #115021 4.8mm ball stud into the top hole of the hub carrier.



STEP 6

Rear Hub Carrier Assembly

- 1 Slide one #151015 10x15x4mm & one #150612mm 6x12x4mm bearing into the left rear hub carrier.
- 2 Slide #502153 wheel axle through #K1462 washer & into the rear hub carrier assembly.
- 3 Slide in #K1418 2x11mm pin through the universal joint. Slide the #K1418 alum. hex wheel adapter over the universal joint & fasten the pin with the cap screw.
- 4 Repeat these steps for the right rear hub carrier assembly.



BAG E

 115002, qty 5 4mm Ball Stud (D3)	 502165, qty 2 Washer (E1)	 126312C, qty 2 3x12mm Cap Screw (E3)	 502162, qty 1 Sliding Steering Spring (E4)	 502162, qty 1 3x20mm FH Screw (E5)	 111007ST, qty 1 3mm Steel Nut (E6)	 502162, qty 4 Sliding Steering Dust Cover (E7)	 502165, qty 4 Sliding Steering Mount Screw (E9)	 116308CR, qty 4 3x8mm Cross FH TP Screw (E11)
 K1432, qty 2 Sliding Steering Mount (E1)	 502160, qty 2 Front Lower Arm (E1)	 502161, qty 1 Front Upper Arm R (E4)	 502161, qty 1 Front Upper Arm L (E4)	 K1470, qty 1 Sliding Steering Servo Saver (E5)	 502162, qty 1 Sliding Steering Servo Saver Arm (E5)	 502170, qty 1 Long Sliding Steering Rail (E9)	 502125, qty 1 #600 Silicone Oil (White Body) (E9)	
 502163, qty 1 Front Bulkhead L (E4)	 502163, qty 1 Front Bulkhead R (E4)	 502164, qty 2 Front Diff Mount (E1)	 502170, qty 1 Sliding Steering Rail (E9)	 K1406, qty 1 Front Anti-Roll Bar Mounts (w/anti-rill bar) (E9)				

STEP 1

Front Lower Arm & Anti-Roll Bar Assembly

- PLEASE READ K FACTORY MANUAL FOR FUTHER ASSEMBLY.**
- Attach #K1406 3x12mm set screw to the #K1406 front anti-roll bar mounts.
- Please insert the anti-roll bar (w/the ball on the end) into the right mount (without the elliptic hole on the right side). Insert the anti-roll bar (w/the cup on the end) into the left mount (w/the elliptic hole on the left side). Thread the 3x3mm set screw into both mounts to fasten the anti-roll bars.
- Attach one #115002 ball stud to the outside hole of both #502160 right & left front lower arm.
- Attach the anti-roll bar set assembly to the #502160 front lower arm with #K1406 knob & #126312C 3x12 cap screw.
- Attach the anti-roll bar set assembly to the #502160 front lower arm with #126312C 3x12 cap screw.

⚠ With the anti roll bars in horizontal position, it will result in the softest setting. At the vertical position it will be the stiffest setting. The knob can be adjusted to reach an equal right-left arm height.

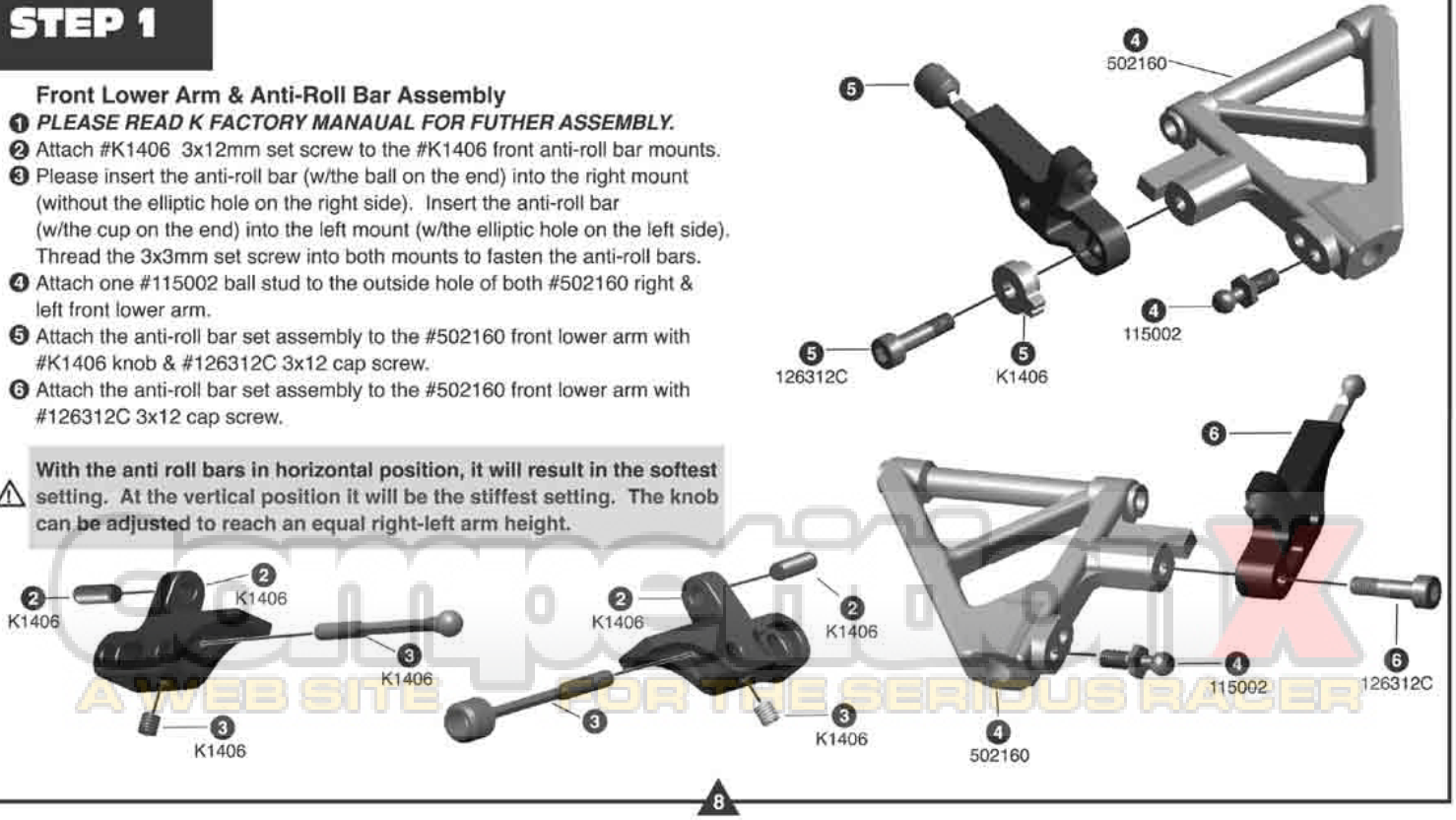

STEP 2

Front Suspension Assembly

- 1 Screw the pivot balls into both # 502161 front upper arm and front lower arm assembly. You want 3mm space between the upper arm & steering block & 2.5mm space between the lower arm & steering block.

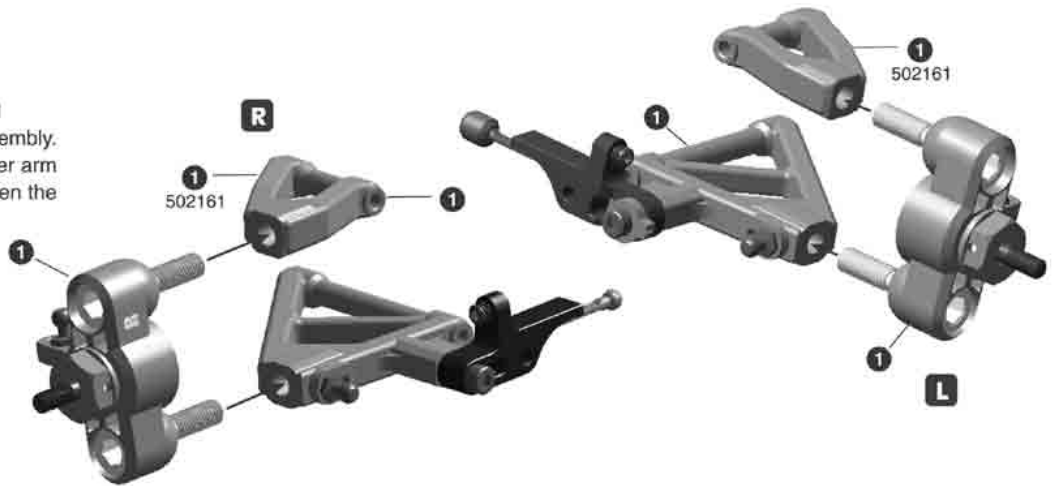
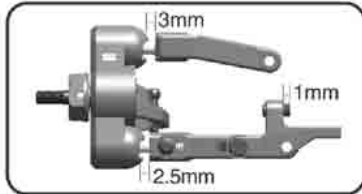

STEP 3

Sliding Steering Servo Saver Assembly

- 1 Thread 2pcs #115002 ball studs into the # 502162 sliding steering servo saver.
- 2 Thread 1pcs #115002 ball stud into # 502162 sliding steering servo saver arm.
- 3 Slide the #502162 spring onto the 3x20mm FH screw. Slide the screw assembly through the bottom of the servo saver assembly.
- 4 Attach the servo saver arm assembly to the servo saver with a #111007ST locknut. Tighten down the screw until the screw end is even with the top of the nut.
- 5 To attach the dust covers, put either #502170 rail through the hole. Peel off the tape on #502162 dust cover & place the tape side through the rail as shown. **DON'T ATTACH THE TAPE TO THE SERVO SAVER. JUST PULL THE RAIL TO MAKE THE COVER STICK TO THE SERVO SAVER.** Please repeat this step to the remaining 3pcs dust cover hole positions.
- 6 Place a drop of #502125 #600 silicone oil on each dust cover.

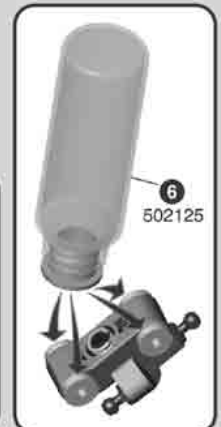
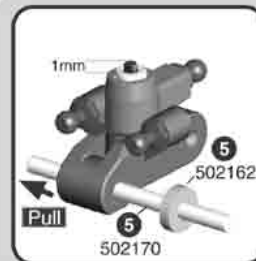
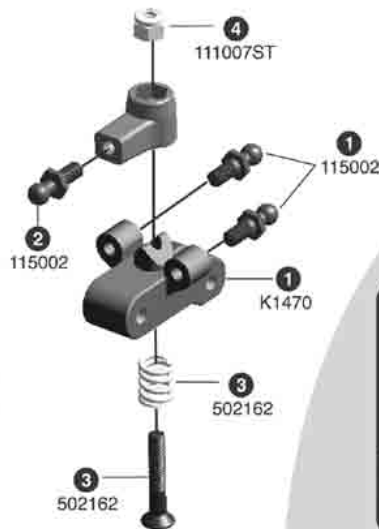

STEP 4

Diff Mount Assembly

- 1 Attach #502165 sliding steering mount to #502163 left front bulkhead with 2pcs #502165 cap screws & washers. **BE GENTLE!! DON'T FULLY TIGHTEN OR OVER TIGHTEN! WE WILL ADJUST THIS MOUNT LATER.**
- 2 Slide #502164 front diff mount into the front bulkhead & fasten with 2pcs #116308CR 3x8mm cross FH TP screws.
- 3 Repeat above 2 steps for the right front bulkhead assembly.

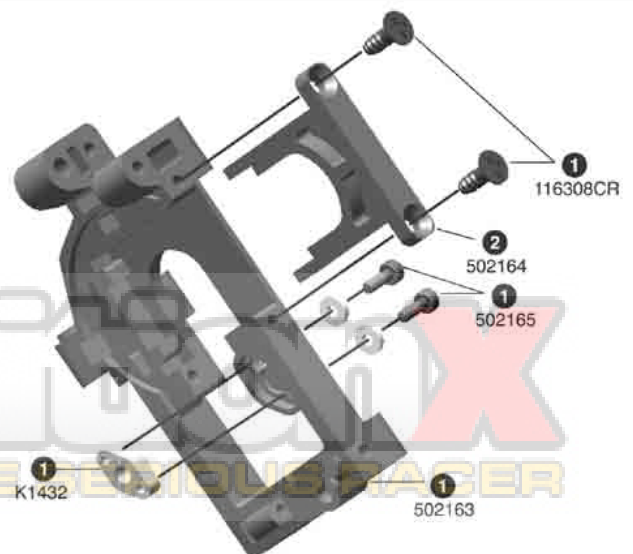

COMPETITION
A WEB SITE FOR THE SERIOUS RACER

BAG F

<p>1:1</p> <p>111007ST, qty 4 3mm Steel Locknut (E6)</p>	<p>1:1</p> <p>502173, qty 1 2x12mm Cross RH TP Screw (E4)</p>	<p>1:1</p> <p>502174, qty 1 Fuel Tank Support (E9)</p>	<p>1:1</p> <p>116308CR, qty 4 3x8mm Cross FH TP Screw (E11)</p>	<p>1:1</p> <p>126320C, qty 2 3x20mm Cap Screw (E6)</p>	<p>1:1</p> <p>502179, qty 2 2mm Caster Clip (E11)</p>	<p>1:1</p> <p>115002, qty 4 Ball Cup (for 3mm rod) (E10)</p>	
<p>K1464, qty 2 Hardened Hinge Pin (Front Lower) (E9)</p>	<p>K1463, qty 2 Hardened Hinge Pin (Front Upper) (E9)</p>	<p>116134-5, qty 2 3x45mm Adjustable Rod (E9)</p>	<p>1:1</p> <p>116312RCR, qty 2 3x12mm Cross RH TP Screw (E6)</p>	<p>1:1</p> <p>116202, qty 2 E-clip 2.5 (E2)</p>	<p>1:1</p> <p>126408S, qty 2 4x8mm Set Screw (E2)</p>	<p>1:1</p> <p>126305S, qty 2 3x5mm Set Screw (E11)</p>	<p>1:1</p> <p>502179, qty 4 1mm Caster Clip (E11)</p>
<p>502170, qty 1 Sliding Steering Rail (E9)</p>	<p>502170, qty 1 Long Sliding Steering Rail (E9)</p>	<p>502171, qty 1 Front Belt (E11)</p>	<p>502180, qty 1 Front Lower Arm Stiffener Brace (E11)</p>	<p>502173, qty 1 Pivoting Body Mount (E3)</p>	<p>502172, qty 1 Nylon Front Upper Stiffener Bracket (E2)</p>	<p>502173, qty 1 5th Body Post (E3)</p>	<p>502175, qty 1 Front Shock Tower (E9)</p>

STEP 1

Front Transmission Assembly

- Slide #502170 sliding steering rails and front diff assembly into the #502163 right side front bulkhead.
- Slide sliding steering servo saver assembly over the rails.
- Slip #502171 front belt (No. 50145) over the front diff and install the left side front bulkhead.

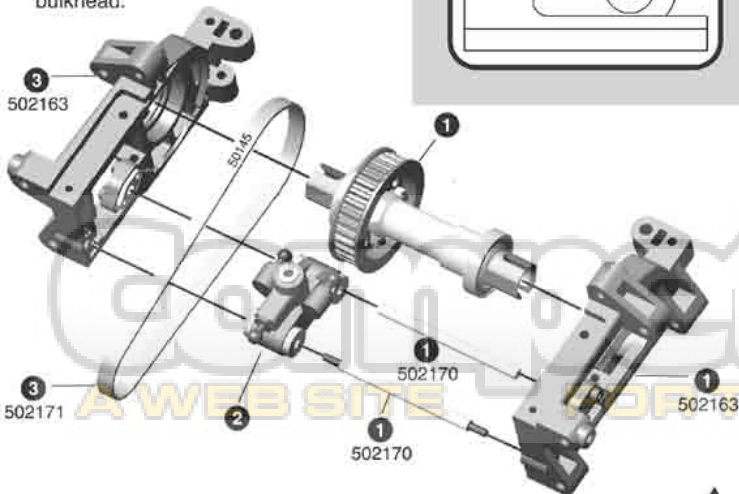
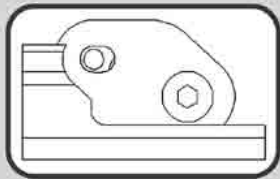

STEP 2

Front Upper Stiffener Bracket Assembly

- Attach #502174 fuel tank support to the #502172 nylon front upper stiffener bracket with a #116308CR 3x8mm cross FH TP screw.
- Attach #502173 5th body post to the nylon front upper stiffener with 1pc 3x8mm cross FH TP screw.
- Slide the #502173 pivoting body mount over the body post so its hole lines up with the fifth hole from the bottom. Then, fasten with a #502173 2x12mm cross RH TP screw. You may need to readjust this depending on your body style.

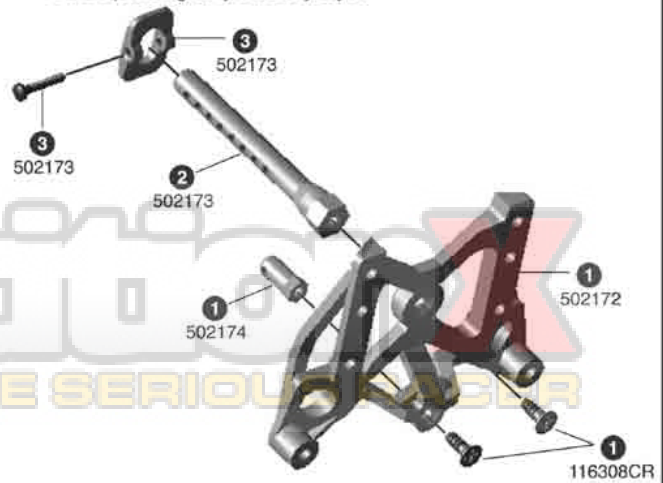

STEP 3

Front Shock Tower Assembly

- 1 Install #126320C 3x20mm cap screws through the lower hole on the #502175 front shock tower.
- 2 Then thread on the #111007ST 3mm steel locknuts & tighten.



STEP 4

- 1 Attach the front upper stiffener assembly to the front bulkheads with 4pcs #116308CR 3x8mm cross FH TP screws.
- 2 Attach the front shock tower assembly to the front bulkheads with 2pcs #116312RCR 3x12 cross RH TP screws.

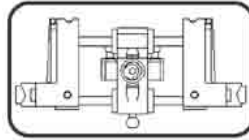

PLEASE ADJUST THE RAIL MOUNTS TO MAKE THE SERVO SAVER MOVEMENT A LITTLE BIT TIGHT & NO EXCESS PLAY. A LITTLE BIT STRESS & TIGHTNESS WILL MAKE THE STEERING SMOOTHER. STRANGE, BUT IT IS TRUE FOR THIS SYSTEM.

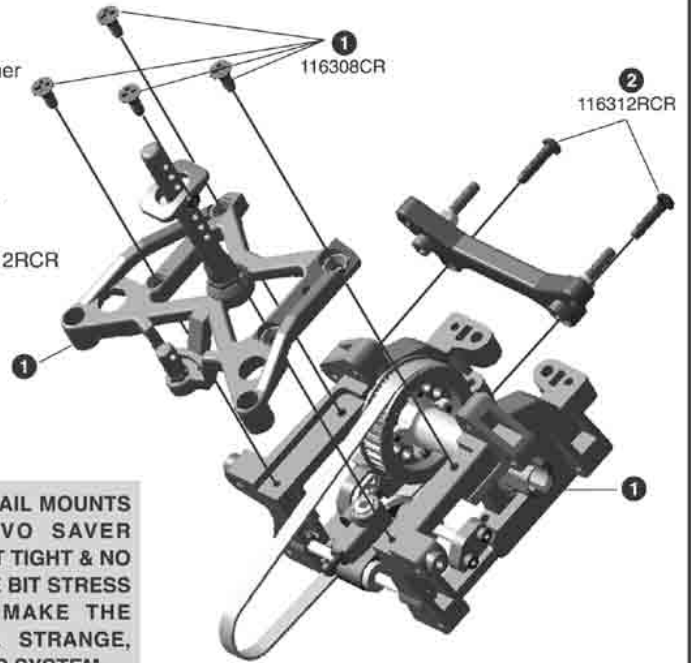

STEP 5

Front Suspension Assembly

- 1 Twist the #115002 ball cups onto the #116134-5 3x45mm adjustable rod until you get the dimension shown (steering rods). Assemble both rods. The end with notch has counter clockwise threads.
- 2 Line up the front lower arm with the bulkhead's lower hole. Push a #K1464 hinge pin (front lower) into the bulkhead & the lower arm.
- 3 Place the #K1462 universal joint in the slot of the front one-way joint cup.
- 4 Line up the front upper arm with the bulkhead's upper hole. Push a #K1463 hinge pin (front upper) into the bulkhead & the upper arm.
- 5 Snap the steering rod into place where shown.
- 6 Please repeat above steps for the left side assembly.

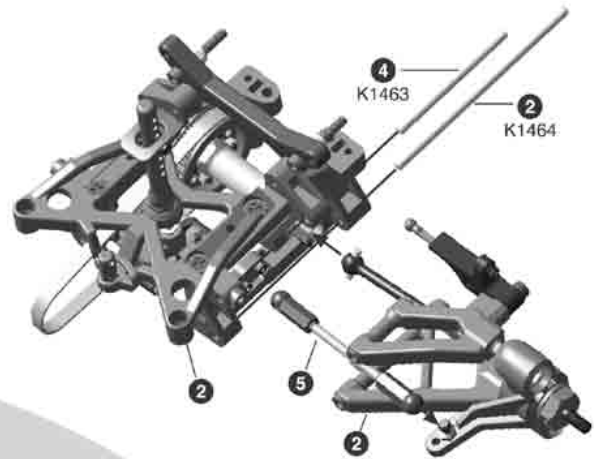
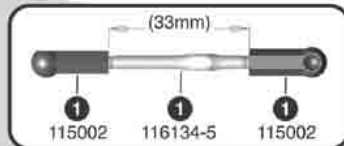

STEP 6

Caster Clip Assembly

- 1 Install #126408S 4x8mm set screw into the bulkhead. **PLEASE REFER TO FINAL ADJUSTMENTS - DROOP SETTING.**
- 2 Install #126305S 3x5mm set screw into the bulkhead. It must contact the flat on the hinge pin.
- 3 Clip in #502179 caster clips. Place all clips on the rear side of the upper arm. **PLEASE REFER TO FINAL ADJUSTMENTS - CASTER SETTING.**
- 4 Please repeat above steps for the left side caster clips assembly.

Sand the arm so that the arm moves freely without any binding or excess play.

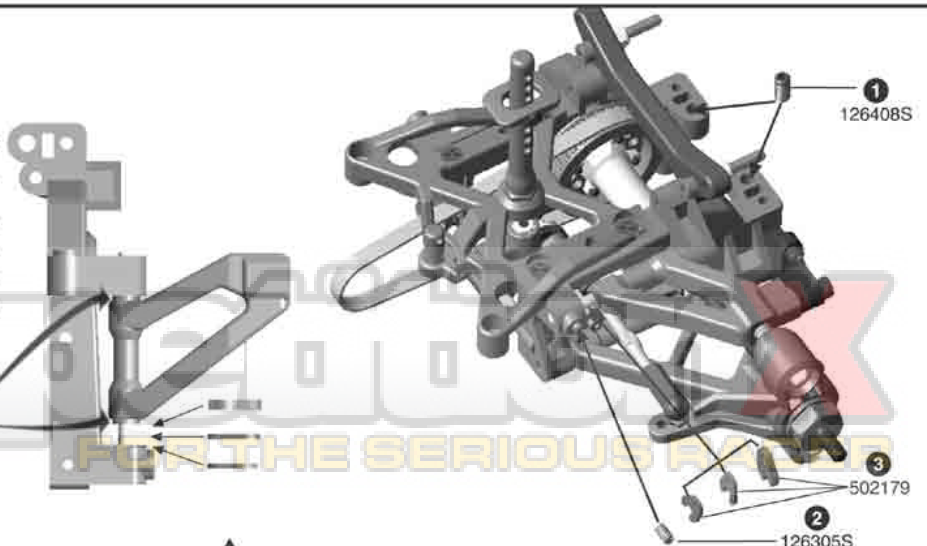







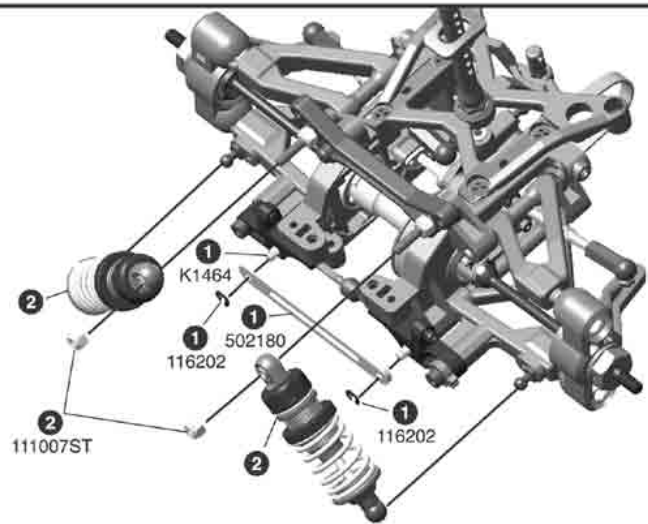







STEP 7

Front Shock Assembly

- Slide #502180 front lower arm stiffener brace onto the end of the #K1464 front lower arm hinge pins & install 2pcs #116202 E-clip 2.5 on the hinge pins.
- Push the Shock cap over the cap screw & add #111007ST locknut. Snap the shock ball cup into place where shown.



BAG G

							
1:1 502183, qty 2 2x12mm Cross RH TP screw G4	1:1 116310RCR, qty 2 3x10mm Cross RH TP screw G2	1:1 111007F, qty 3 3mm flat locknut G5	1:1 126308CR, qty 3 3x8mm Cross FH Screw G6	1:1 116310CR, qty 4 3x10mm Cross FH TP screw G7	1:1 502186, qty 2 Bumper Foam Post Washer G1	1:1 111120, qty 2 R6 R-clip G9	
							
502187, qty 1 3mm Chassis G4	502184, qty 1 Front Lower Bumper G1	502185, qty 1 Front Upper Bumper G1	502188, qty 1 Bumper Foam G6	502183, qty 2 Front Body Post G3	502186, qty 2 Bumper Foam Post G1	502186, qty 4 Bumper Foam Post Pad G3	502183, qty 2 Pivoting Body Mount G3

STEP 1

Front Upper Bumper Assembly

- Attach 2pcs #502183 body posts to the #502185 front upper bumper with 2pcs #116310RCR 3x10mm cross RH TP screws.
- Slide #502183 pivoting body mounts over the body posts so the holes line up with the second hole from the bottom. Then, fasten with #502183 2x12mm cross RH TP screws.

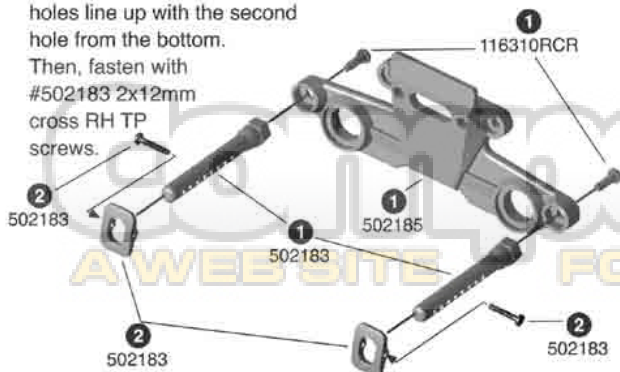

STEP 2

Front Lower Bumper Assembly

- Align 3pcs #111007F 3mm flat nuts with hexagonal slots on the #502184 front lower bumper. Attach the front lower bumper to the #502187 chassis with 3pcs #126308CR 3x8mm cross RH screws.
- foam bumper post pads into the front lower bumper, making sure the shoulder is facing down. Slide #502186 foam bumper posts through the pads.

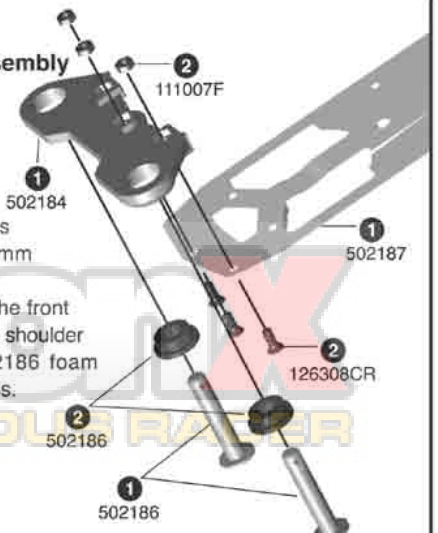

STEP 3

- 1 Attach the front suspension system assembly to the #502187 chassis with 4pcs #116310CR 3x10mm cross FH TP screws.
- 2 Place the #502188 foam bumper on the lower bumper assembly.

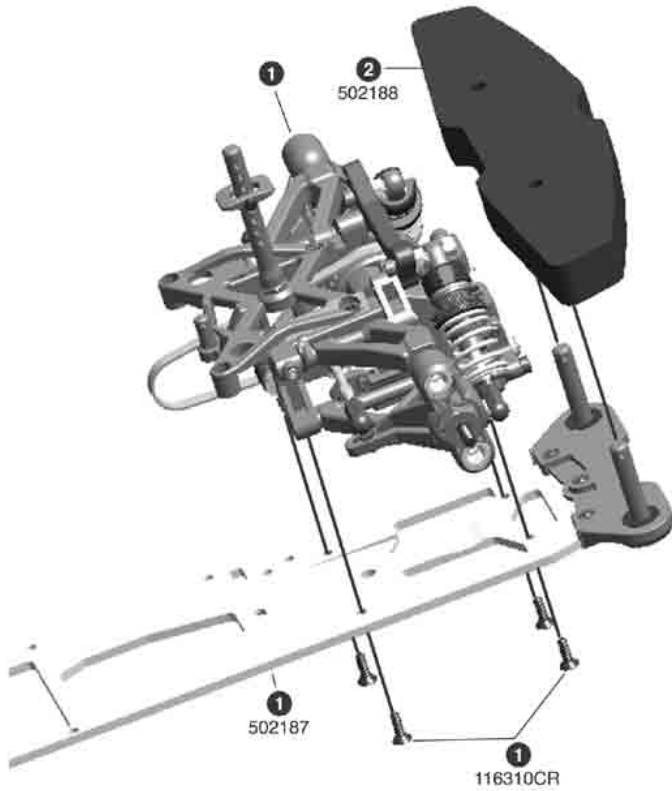

STEP 4

Front Upper Bumper Assembly

- 1 Attach the front upper bumper assembly to the foam bumper assembly with 2pcs #116310RCR 3x10mm cross RH TP screws.
- 2 Slide #502186 pads & washers through foam bumper posts & slide in #111120 R6 R-clips.

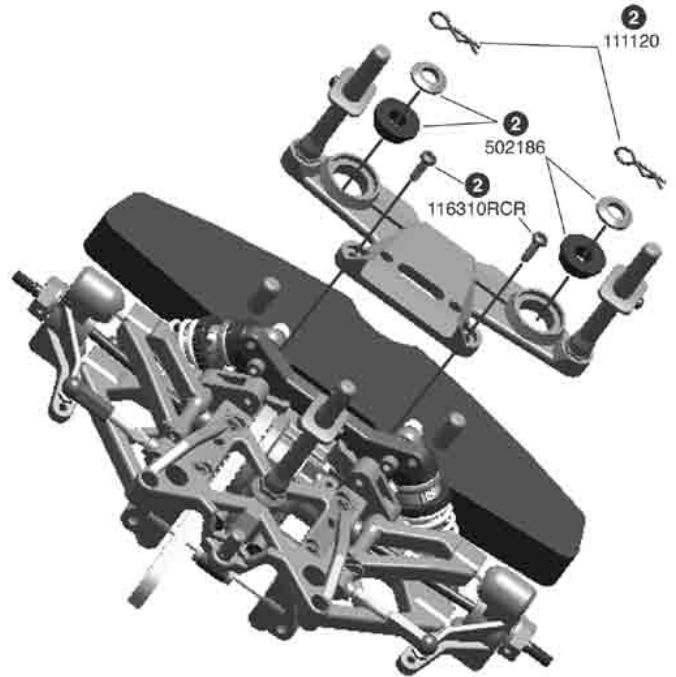

BAG H

1:1



116202, qty 4
E2.5 E-clip

H5

1:1



502191, qty 2
2x10mm Cross
RH TP Screw

H2

1:1



502191, qty 2
2x12mm Cross
RH TP Screw

H6

1:1



116312RCR, qty 2
3x12mm Cross RH
TP Screw

H8

1:1



502192, qty 2
Alum. 4x18mm
Adjustable Rod

H3

1:1



K1465, qty 2
Hardened Hinge Pin
(Rear Upper)

H9

1:1



502193, qty 1
Ball Cup
(for 4mm rod)

H4



502190, qty 1
Rear Shock Tower

H1



502193, qty 1
Rear Upper
Rod End

H9



502191, qty 2
Pivoting Body
Mount

H3



502191, qty 2
Extension
Body Post

H1



502191, qty 2
Rear Body Post

H1

STEP 1

Rear Body Post Assembly

- Place the #502191 rear body posts to the front side of the #502190 rear shock tower. Attach the posts with #116312RCR 3x12mm cross RH TP screws.
- Slide the #502191 pivoting body mounts over the body posts so the holes line up with the fourth hole from the bottom, then attach #502191 2x12mm cross RH TP screws to hold the body mount in place. You may need to readjust this depends on your body style.
- If the rear body post is not tall enough, please use #502191 extension body posts to extend the height. Slide the #502191 extension body post over the rear body post so its holes line up with the second hole from the top, then attach a #502191 2x10mm cross RH TP screw to hold the extension mount in place.
- Slide the #502191 pivoting body mounts over the extension body posts so the holes line up with the second hole from the top, then attach #502191 2x12mm cross RH TP screws to hold the body mount in place. You may need to readjust this depends on your body style.

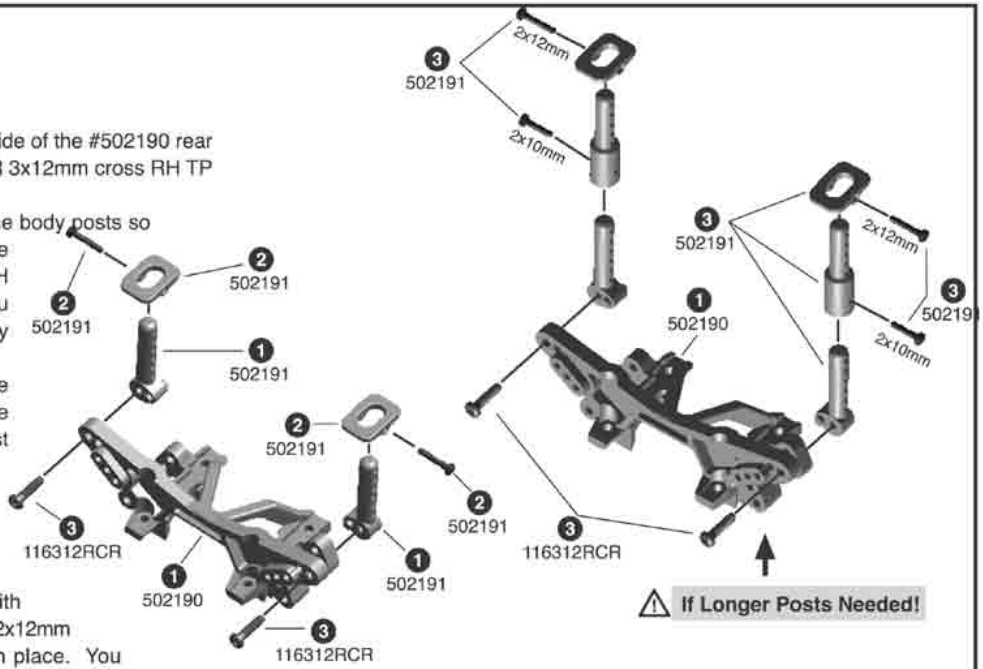

STEP 2

Rear Upper Link Assembly

- Twist the #502193 ball cup & rod end onto the #502192 alum. 4x18mm adjustable rod until you get the dimension shown. Assemble both rear upper arms.
- Line up the rear upper link assembly with the lower hole on the shock tower. Push #K1465 rear upper hinge pins into the tower & arm. Install #116202 E-clip 2.5 on both side of the hinge pins.

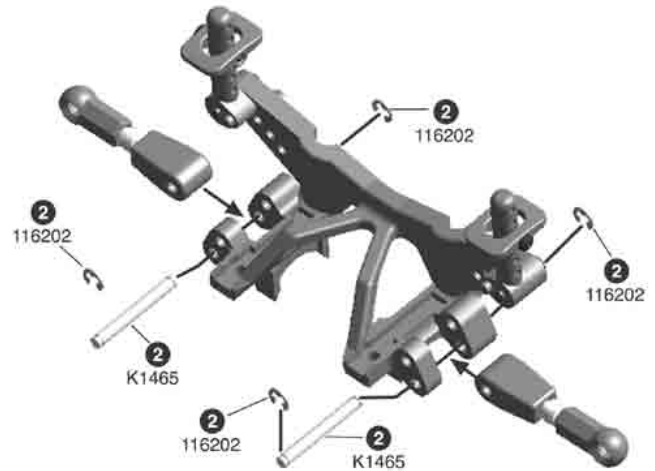
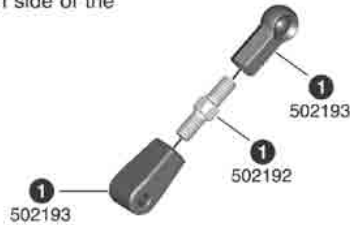

CompetitionX
A WEB SITE FOR THE SERIOUS RACER

BAG I

	1:1 	1:1 	1:1 	1:1 	1:1 	1:1 	1:1 	1:1
502202, qty 1 19T Brake Pulley Mount 18	502202, qty 1 4x4mm Set Screw 18	502197, qty 1 Brake Cam Cylinder 12	116201, qty 2 2x11mm Pin 08	116310CR, qty 2 3x10mm Cross FH TP Screw 07	126314BU, qty 2 3x14mm Button Head Screw 14	126408S, qty 1 4x8mm Set Screw 02	150612, qty 1 6x12x4mm Bearing 06	116203, qty 1 E5 E-clip 19
502202, qty 1 19T Brake Pulley Gear 18	502203, qty 1 2 Speed Housing Dust Cover 11	502198, qty 2 Brake Pad 03	502198, qty 2 Brake Plate 03	502197, qty 1 Brake Cam 02	502201, qty 1 Brake Disc 17	502199, qty 1 Right Alum. Side Plate 15	502200, qty 1 2 Speed Shaft 05	502196, qty 1 Right Rear Bulkhead 07

STEP 1

Right Rear Bulkhead Assembly

- Lightly scuff the side of # 502198 brake pad you will be gluing the pad to. The elongated hole on the pad and plate must face down. Apply some contact cement to one side of the pad and one side on the plate. Attach them together.
- Slide #502197 brake cam into #502196 right rear bulkhead.
- Fit #502197 brake cam cylinder into the right rear bulkhead.
- Attach two brake plate assemblies to with two screws. You want to thread the screw in until there is a 2mm space between the 2 pads.

Use CA Or Contact Cement

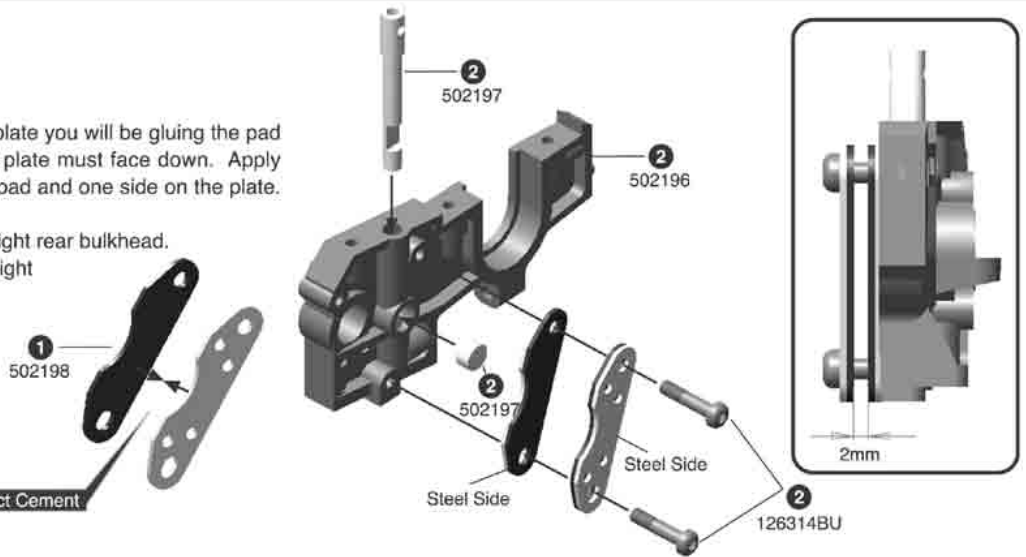

STEP 2

Right Alum. Side Plat Assembly

- Install a #126408S 4x8mm set screw into the #502196 right rear bulkhead. **PLEASE REFER TO FINAL ADJUSTMENTS - UP STOP SETTING.**
- Attach the #502199 right alum. side plate to the right rear bulkhead with two #116310CR 3x10mm cross FH TP screws.

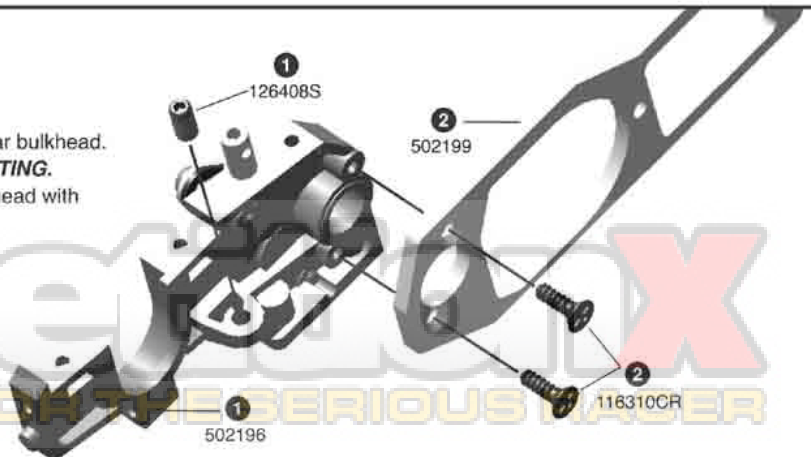

STEP 3

19T Brake Pulley Assembly

- 1 Please slide the #502202 19T brake pulley gear into the 19T brake pulley mount.
- 2 Install the #502202 4x4mm set screw into the 19T brake pulley. Just turn the set screw 2~3 turns.

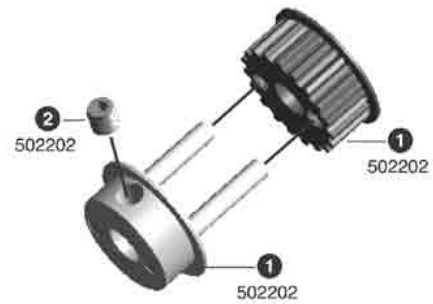

STEP 4

2 Speed Shaft Assembly

- 1 Place the #502201 brake disc between two brake pads. The brake disc should be sandwiched. Slide the 2 speed shaft through the brake disc & the bulkhead.
- 2 Slide a #150612 6x12x4mm bearing down the 2 speed shaft & into the slot of the right alum. side plate.
- 3 Install & center a #116201 2x11mm pin into the 2 speed shaft.
- 4 Slide 19T brake pulley assembly onto the 2 speed shaft. Align the 2x11mm pin with the brake pulley slot. The pins of 19T brake pulley should go through the brake disc.

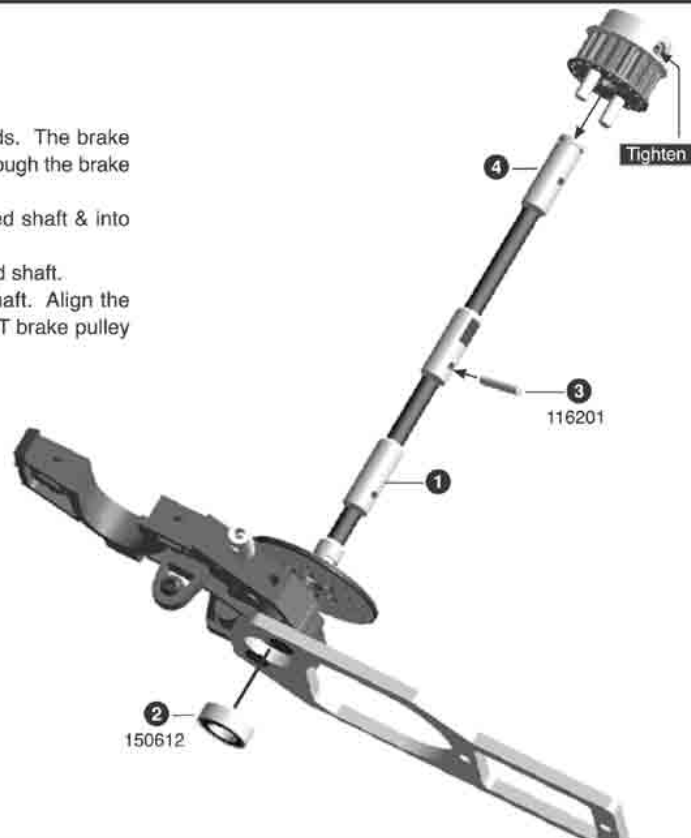

STEP 5

2 Speed System Assembly

- 1 Slide the 2 speed housing onto the 2 speed shaft
- 2 Install & center a #116201 2x11mm pin into the 2 speed shaft.
- 3 Slide the 2 speed shoe assembly onto the 2 speed shaft, lining up the pin with the slot in the 2 speed shoe adaptor.
- 4 Slide the one way hub onto the 2 speed shaft. Now push #116203 E5 E-clip into place. Snap the #502203 dust cover on.

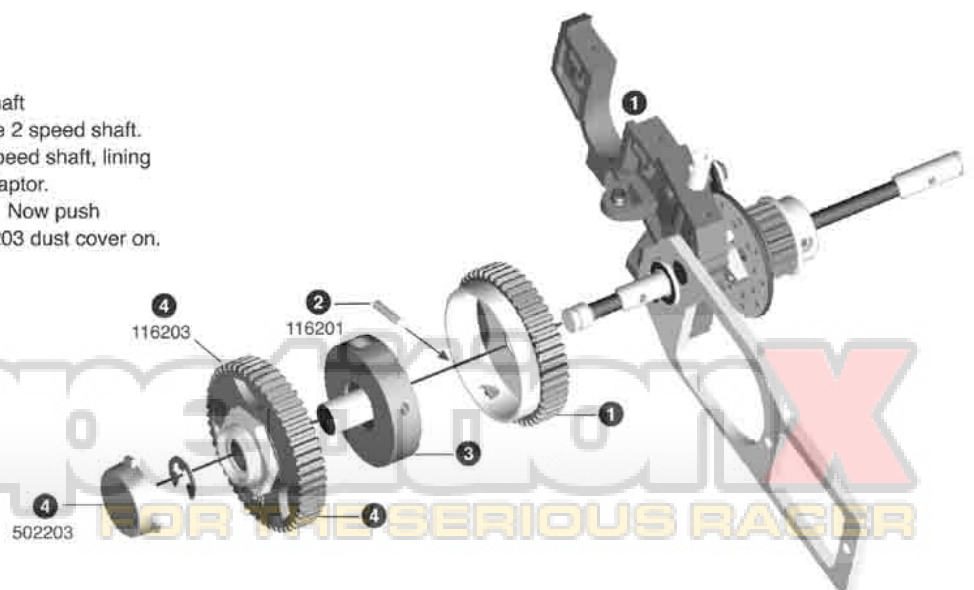

BAG J



126314BU, qty 2
3x14mm Button
Head Screw (14)



116310CR, qty 4
3x10mm Cross
FH TP Screw (17)



126408S, qty 3
4x8mm Set
Screw (12)



150612, qty 1
6x12x4mm
Bearing (16)



116201, qty 1
2x11mm Pin
(18)



116203, qty 1
E5 E-clip
(19)



502208, qty 2
Rear Lower
Arm Spacer (13)



116308CR, qty 4
3x8mm Cross
FH TP Screw (11)



115002, qty 3
4mm Ball Stud
(10)



126310, qty 1
3x10mm FH
Screw (15)



111003S, qty 1
3mm FH
Washer (17)



150508, qty 2
5x8mm Bearing
(13)



502211, qty 1
Belt Tensioner
Post (13)



111041, qty 1
3mm Cap
Washer (14)



150508F, qty 1
5x8mm Flanged
Bearing (15)



126306RCR, qty 1
3x6mm Cross
RH Screw (14)



116312RCR, qty 1
3x12mm Cross
RH TP Screw (16)



502197, qty 1
Brake Lever
(12)



502207, qty 1
19T Pulley Lid
(13)



502207, qty 1
19T Pulley
Gear (13)



k1466, qty 2
Hardened
Hinge Pin
(Rear Lower)
(18)



502176, qty 2
Drive Shaft
(17)



502199, qty 1
Left Alum.
Side Plate (11)



502196, qty 1
Left Rear
Bulkhead (12)



502206, qty 1
Rear Belt
(11)



502208, qty 2
Rear Lower
Arm (12)



502196, qty 1
Back Bracket
(12)



502213, qty 1
Left Radio
Plate Support
(13)



502196, qty 1
Brake Bracket
(12)



502211, qty 1
Belt Tensioner
Roller (13)



K1407, qty 1
Rear Anti-Roll
Bar Mounts
(w/anti-roll bar)
(18)

STEP 1

Right Side Alum. Side Plate Assembly

- 1 Install a #116408S 4x8mm set screw into the #502196 left rear bulkhead.
- 2 Attach the #502199 left alum. side plate to the left rear bulkhead with two #116310CR 3x10mm cross FH TP screws.
- 3 Insert a #150612 6x12x4mm bearing into the slot of the left alum. side plate.

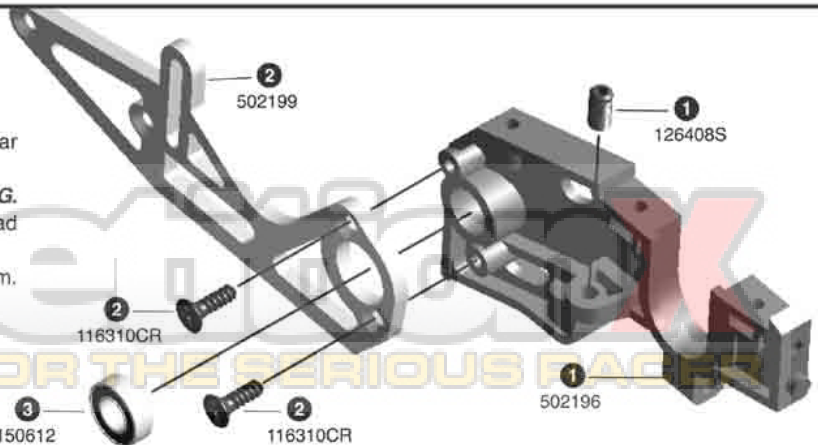

A WEB SITE FOR THE SERIOUS RACER

STEP 2

Left Alum. Side Plate Assembly

- 1 Attach the #502207 19T pulley lid to the 19T pulley gear.
- 2 Slip #502206 rear belt over the 2 speed shaft (19T brake pulley) and install the left side bulkhead assembly.
- 3 Install and center a #116201 2x11mm pin into the 2 speed shaft. Slide the #502207 19T pulley onto the 2 speed shaft, lining up the pin with the slot in the 19T pulley.
- 4 Now push #116203 E5 E-clip into place.

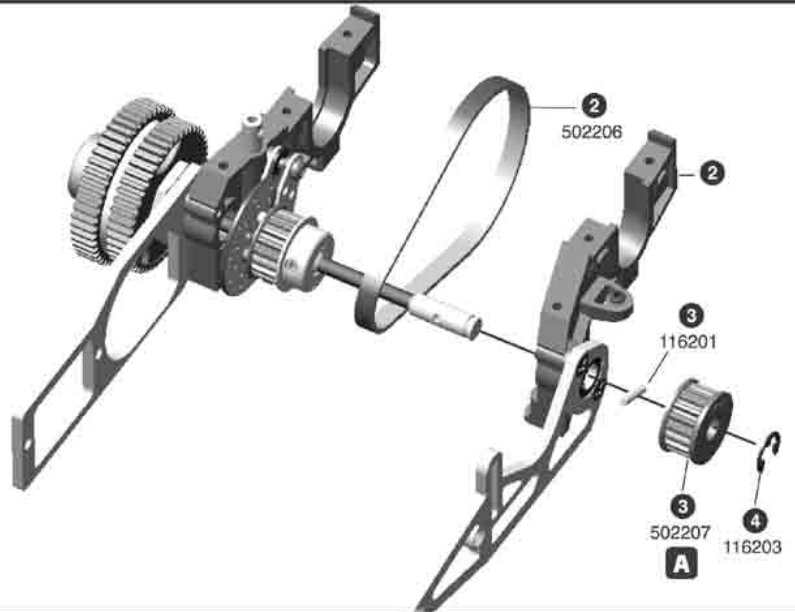

STEP 3

Rear Lower Arm & Rear Anti-Roll Bar Assembly

- 1 **READ K FACTORY K1407 MANUAL.**
- 2 Please insert the anti-roll bar (w/the ball on the end) into the right mount (without the elliptic hole on the right side). Insert the anti-roll bar (w/the cup on the end) into the left mount (w/the elliptic hole on the left side).
- 3 Thread the #K1407 3x3mm set screw into both mounts to fasten the anti-roll bars.
- 4 Install a #126408S 4x8mm set screw into each of the #502208 rear lower arms. Thread a #115002 4mm ball stud into each outside hole of the rear lower arms. **PLEASE REFER TO FINAL ADJUSTMENTS - DROOP SETTING.**
- 5 Please attach the anti roll bar assembly to the rear suspension with the included screws. The knob is included.
- 6 Slide the #K1466 hardened hinge pins (rear lower) through the rear lower arms. Slide the rear lower arm assembly into the holes of the rear bulkheads.
- 7 Align the #502196 back bracket with the #K1466 rear lower hinge pins & slide together. Tighten it down with two #116310CR 3x10mm cross FH TP Screws.

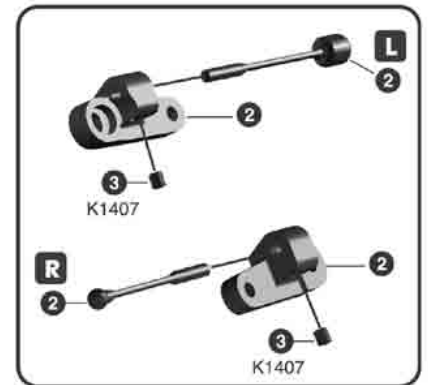

⚠ With the anti roll bars in horizontal position, it will result in the softest setting. At the vertical position it will be the stiffest setting. The knob can be adjusted to reach an equal right-left arm height.

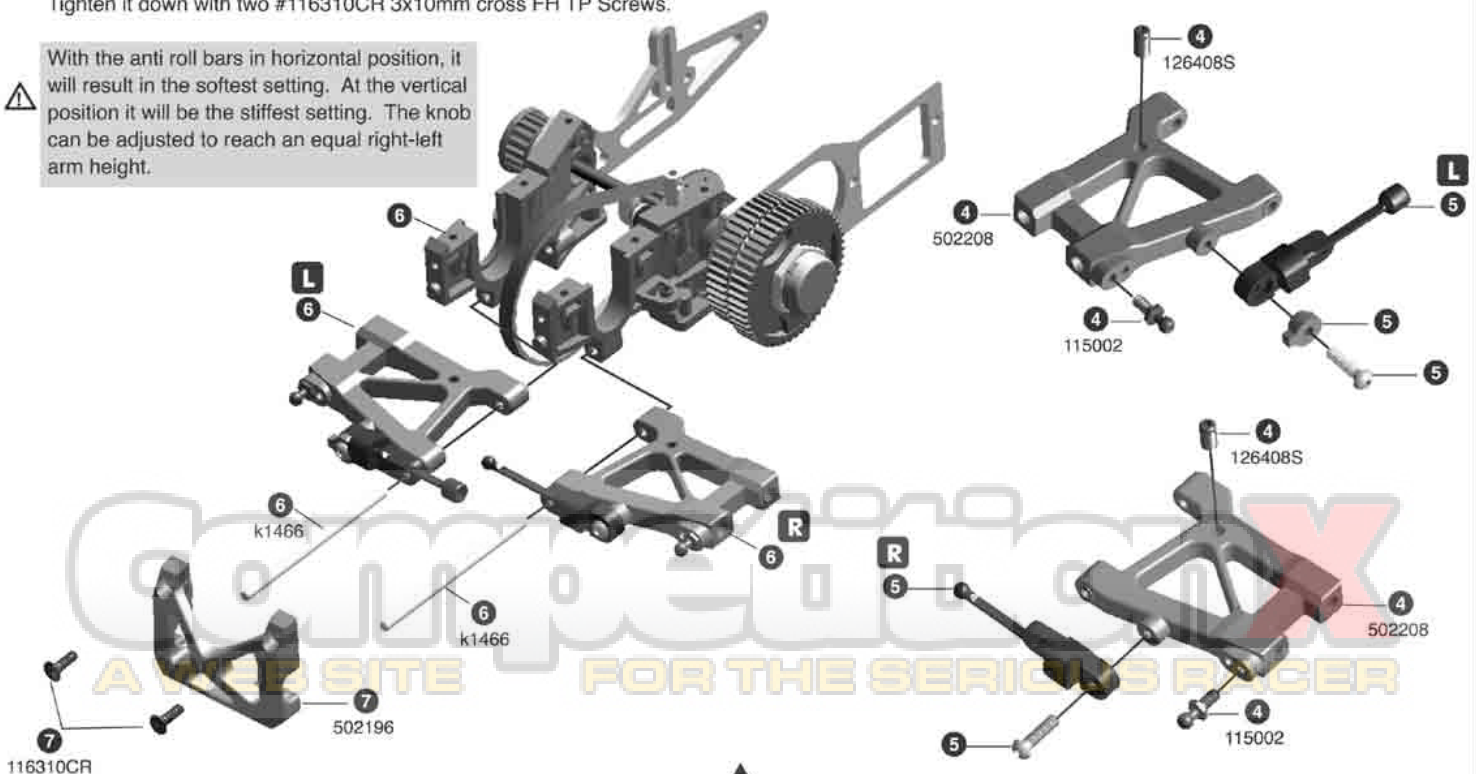

STEP 4

Rear Diff Installation

- 1 Angle the rear diff assembly & slide it through the rear belt. Place the rear diff assembly into the rear bulkheads.
- 2 Place a #150508F 5x8mm flanged bearing over the brake cam.
- 3 Attach the #502196 brake bracket to the rear bulkheads with two #116308CR 3x8mm cross FH TP screws.

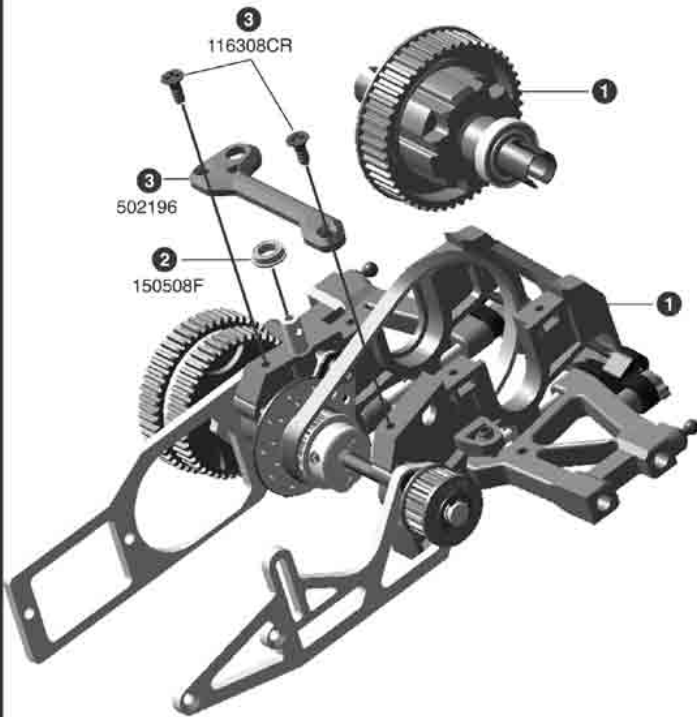

STEP 5

Rear Shock Tower Installation

- 1 Install & center a #116206 2x10mm pin into the brake cam. Slide the #502197 brake lever onto the brake cam & tighten with a #11041S 3mm cap washer & a #126306RCR 3x6mm cross RH screw.
- 2 Install a #115002 4mm ball stud into the brake lever.
- 3 Attach the rear shock tower assembly to the rear bulkheads with 4pcs #116312RCR 3x12mm cross RH TP screws.

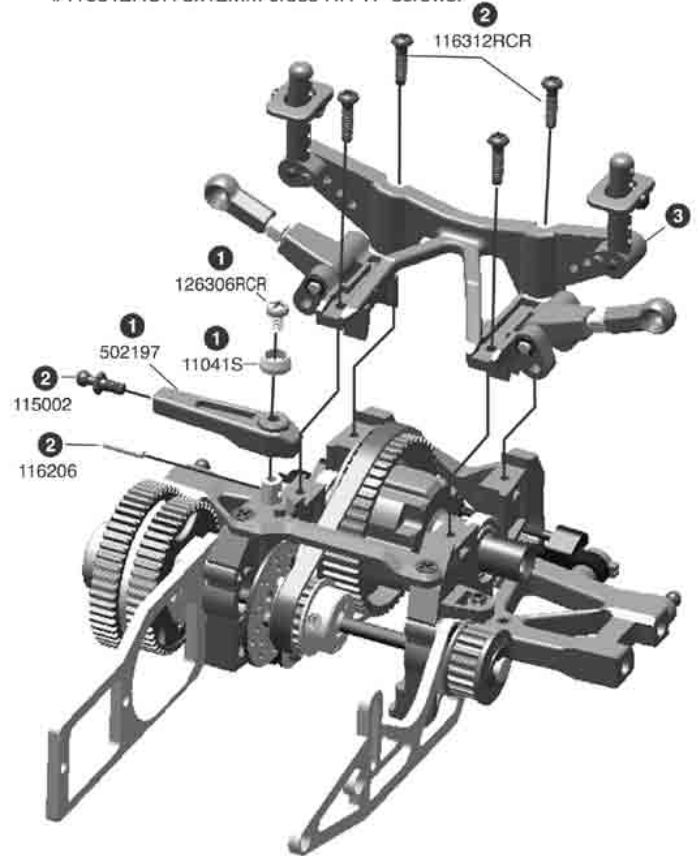

STEP 6

Rear Hub Carrier Installation

- 1 Screw the pivot balls into the rear lower arm. Thread the front pillow ball until the space between the hub carrier & arm is 3mm. Thread the rear pillow ball until the space between the hub carrier & arm is 4mm.
- 2 Make sure the #502176 drive shaft is in the slots of both the diff joint & wheel axle.
- 3 Snap the rear upper arm ball cup into place where shown.
- 4 Repeat the above steps for the left side hub carrier.

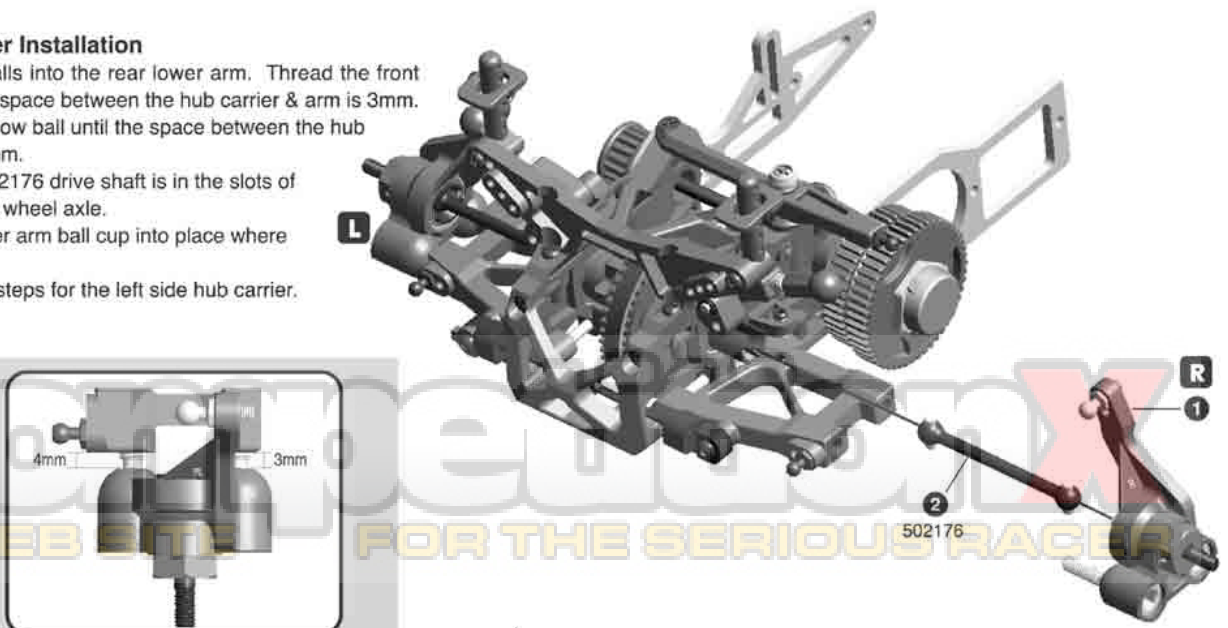

STEP 7

Rear Shock Installation

- 1 Fasten the shock caps into the lower hole of the shock tower with 126314BU 3x14mm BH screws.
- 2 Snap the shock ball cup into place.

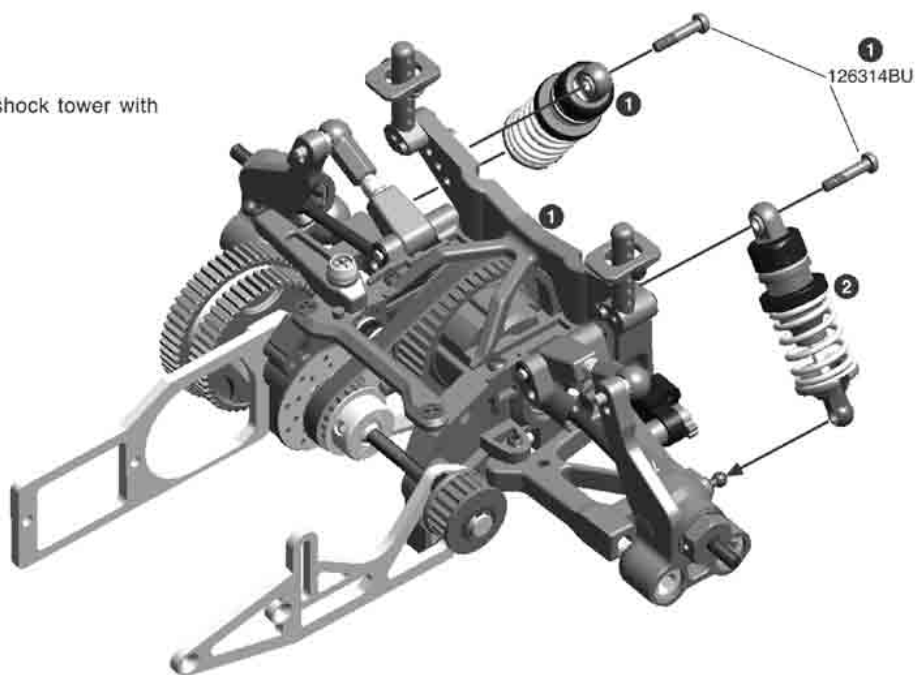

STEP 8

Belt Tensioner Assembly

- 1 Install a #150508 5x8mm bearing on both side of the #502211 belt tensioner roller. Slide the roller assembly onto the post.
- 2 Please attach the belt tensioner to the left side alum. plate with a #111003S 3mm washer & a #116310 3x10mm FH screw.
- 3 Attach the #502213 left radio plate support to the left side alum. plate with two #116308CR 3x8mm cross FH TP screws.

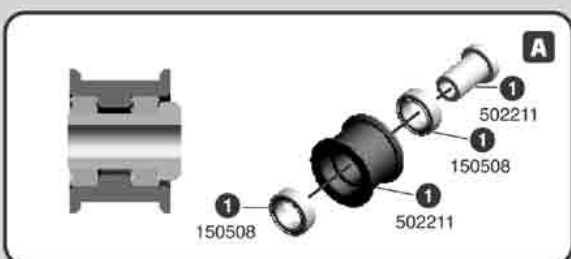
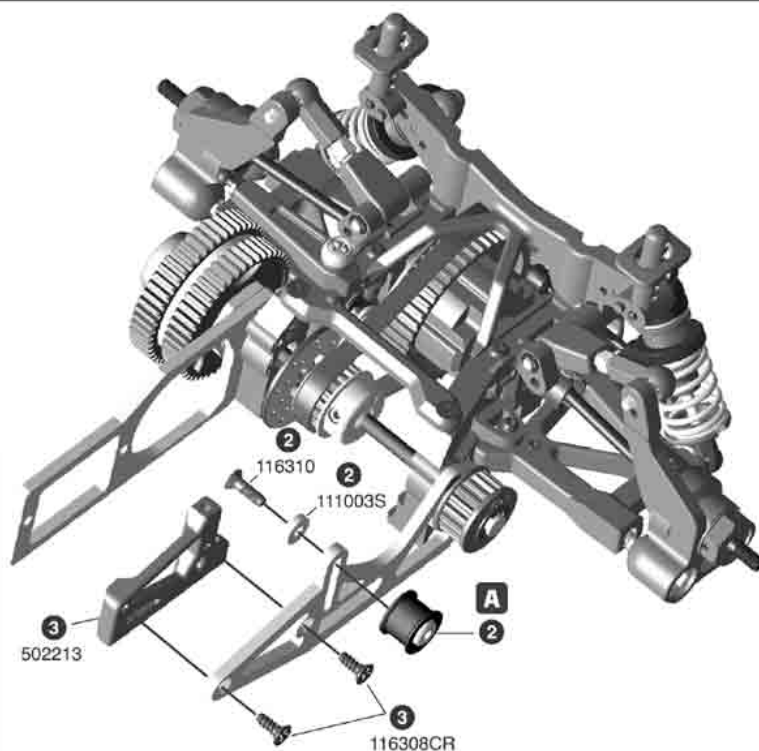

CompetitionX
A WEB SITE FOR THE SERIOUS RACER

BAG K

 1:1 150508F, qty 1 5x8mm Flanged Bearing JS	 1:1 116306BDCR, qty 5 3x6mm Cross BDH TP Screw KS	 1:1 502217, qty 2 Throttle Pivot KS	 1:1 502217, qty 2 Short 4mm Ball Stud KS	 1:1 502217, qty 1 2.6x8mm Cross RH Screw KS	 1:1 502174, qty 1 P5 O-ring KS	 1:1 116312RCR, qty 1 3x12mm Cross RH TP Screw FS	 1:1 116308RCR, qty 5 3x8mm Cross RH TP Screw KS	 1:1 115016BK, qty 1 Antenna Cap KS	 1:1 115002, qty 2 Ball Cup (for 3mm rod) KS
 502221, qty 1 Servo Arm (Futaba) KS	 116132, qty 1 3x20mm Adjustable Rod FS	 115016BK, qty 1 Antenna Rod KS	 502220, qty 1 Double Side Tape KS	 502219, qty 1 Steering Servo Mount KS	 502217, qty 1 Throttle Linkage Arm KS	 502217, qty 1 Throttle Linkage Mount KS	 502222, qty 2 Servo Spacer 2.4mm KS	 502222, qty 2 Servo Spacer 1.2mm KS	 K1408, qty 1 G4 Carbon Radio Plate KS
 502223, qty 1 Servo Arm (Ko, Sanwa & JR) KS	 502220, qty 1 Receiver Battery Mount KS	 502219, qty 1 Servo & Transponder Mount KS	 502213, qty 1 Right Radio Plate Support KS	 502174, qty 1 Handle KS	 502220, qty 1 Rubber Fastener KS	 K1408, qty 1 G4 Carbon Radio Plate KS			

STEP 1

Throttle Linkage Set Assembly

READ K FACTORY K1408 MANUAL FIRST!!

- 1 Please slide the two o-rings through the small receiver holder carbon plate & over the two alum. posts.
- 2 Please attach the carbon receiver holder assembly to the #K1408 carbon radio plate with the two included screws.
- 3 Slide a #150508F 5x8mm flanged bearing into #502217 throttle linkage mount.
- 4 Attach the #502217 throttle linkage arm to the throttle linkage mount assembly with a #116306BDCR 3x6mm cross BDH TP screw.
- 5 Thread a #502217 short ball cup to the outside hole of the throttle linkage arm.
- 6 Attach #502217 throttle pivots to the throttle linkage horn with #502217 2.6x8mm cross RH screws.
- 7 Attach the whole throttle linkage to the #K1408 carbon radio plate with two #116306BDCR 3x6mm cross BDH screws.

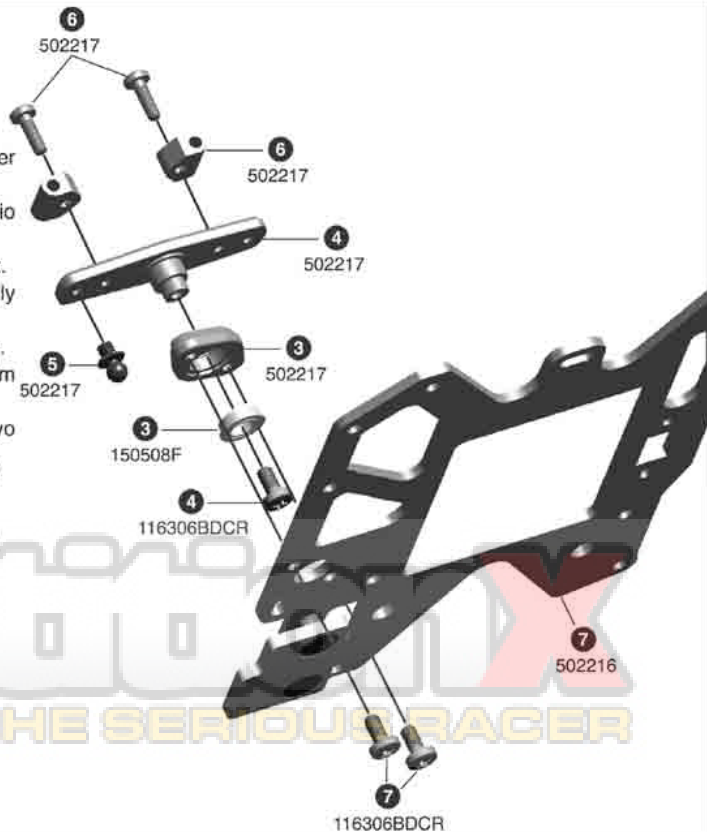

STEP 2

- 1 Install a #502174 P5 O-ring over the #502174 handle.
- 2 Slide a #116312RCR 3x12mm cross RH TP screw over the handle & radio plate to tighten the #502213 right radio plate support.
- 3 Attach the right radio plate support to the radio plate with another #116308RCR 3x8mm cross RH TP screw.
- 4 Attach the #502219 transponder mount to the radio plate with two #116308RCR 3x8mm cross RH TP screws.

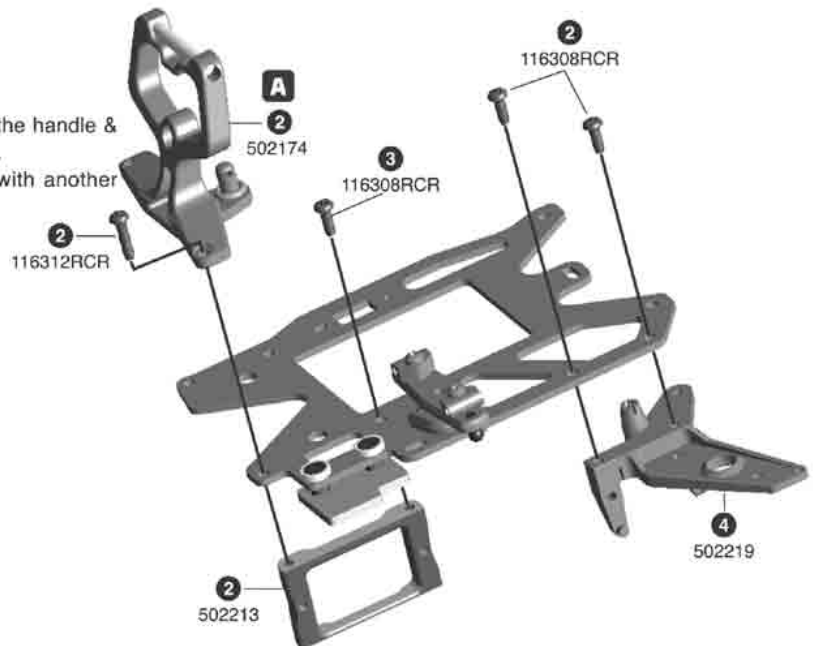

STEP 3

Receiver Pack Assembly

RECEIVER BATTERY IS NOT INCLUDED. SMALL AAA SIZE RECEIVER BATTERY PACK SHOULD BE USED. SUGGESTED ITEMS: 114019-- 6v-650mah NI-MH Rectangle Receiver Pack

- 1 Cut the #502220 rubber fastener to a suitable size in order to hold the receiver battery assembly.
- 2 Cut a piece of suitable size #502220 double side tape. Attach the tape to both receiver battery pack & #502220 receiver battery mount. Then, fasten the whole receiver battery assembly with the rubber fastener.

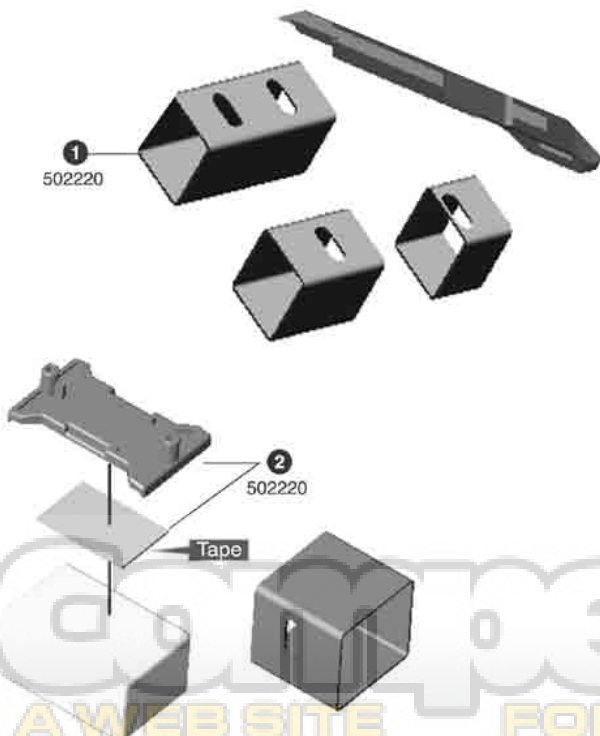

STEP 4

Receiver Battery Installation

- 1 Attach the switch to the radio tray with the stock switch.
- 2 Attach the receiver battery mount assembly to the radio plate with two #116306BDCR 3x6mm cross BDH TP screws.

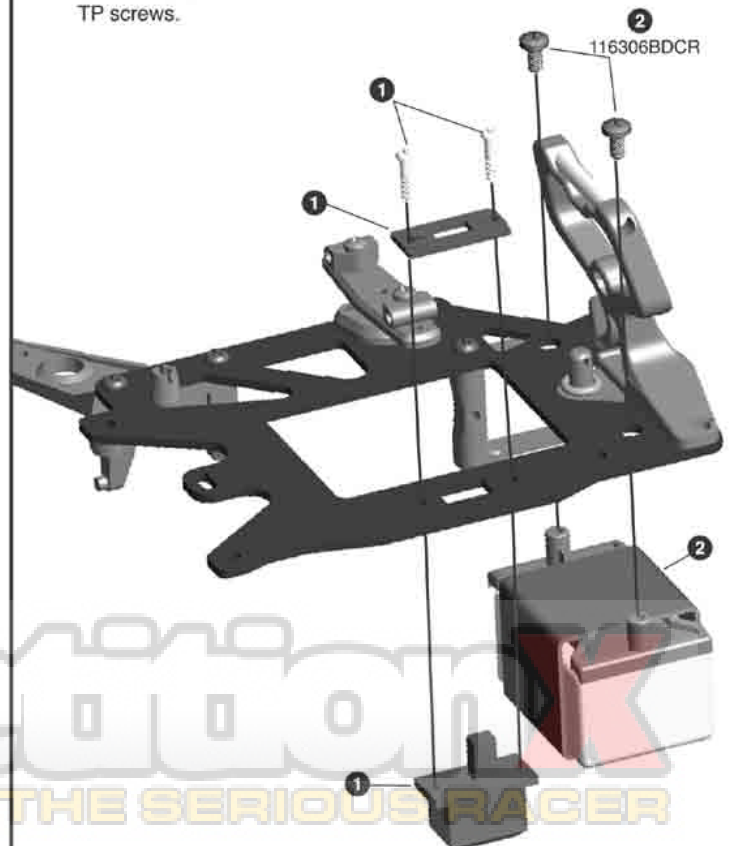

STEP 5

Steering Servo Assembly

- 1 Attach the #502219 steering servo mount to the radio plate with a #116308RCR 3x8mm cross RH TP screw.
- 2 **READ K FACTORY K1408 MANUAL.** Attach the receiver to the radio plate receiver holder. Take your antenna wire (receiver) & push it through the built in antenna mount on the #502219 servo mount & transponder mount. Slide the wire through #115016BK antenna rod & push the rod firmly into the mount. Cap the end with the black rubber cap. **PLEASE ARRANGE THE WIRE AS SHOWN.**
- 3 When attach the receiver to the holder, please take care that the receiver should be flush with holder edge. Otherwise, it will be difficult to slide in the alum. side plate.

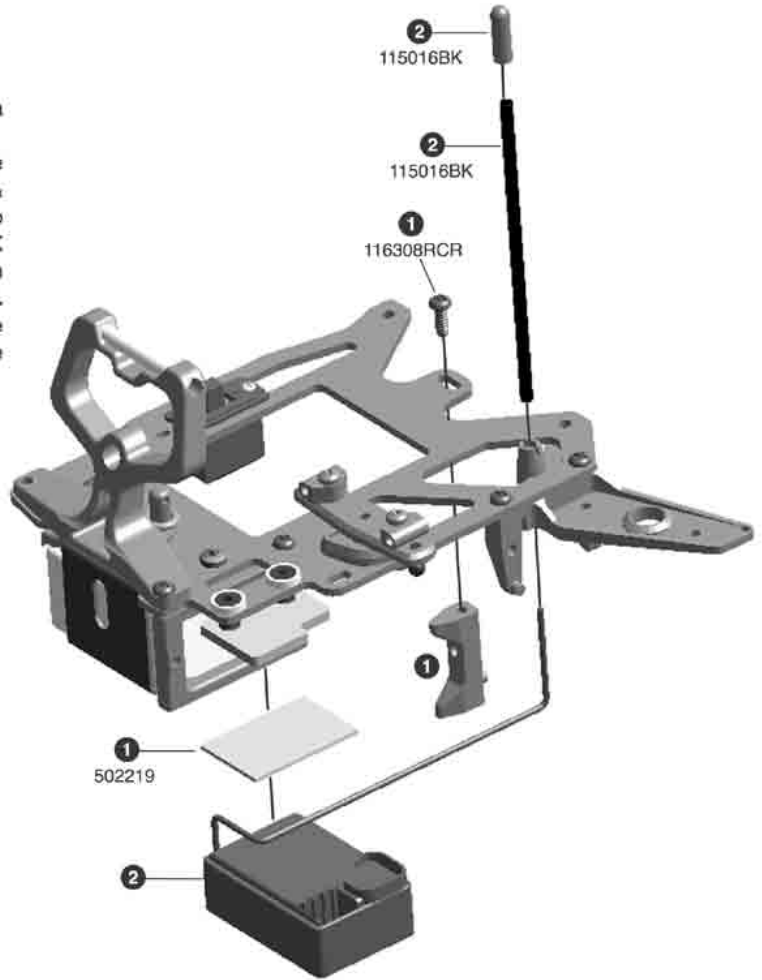
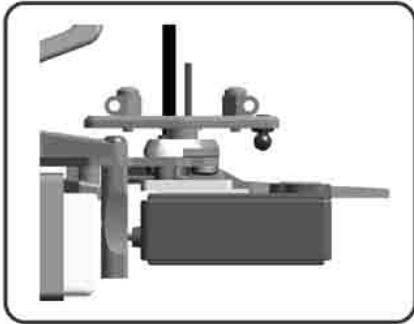

STEP 6

Steering Servo Installation

- 1 Twist #115002 ball cups (for 3mm rod) onto the #116132 3x20mm adjustable rod until you get the dimension shown.
- 2 Find the appropriate thick or thin #502222 servo spacer for your servo. **THE STEERING LINKAGE ROD SHOULD BE PARALLEL TO THE SLIDING STEERING RAIL WHEN CONNECTING TO THE SERVO SAVER.** Attach the spacer if any, in between the #502219 servo mount & steering servo with the #116308RCR 3x8mm cross RH TP screws.
- 3 Find the appropriate #502221 or #502223 servo arm for your steering servo. Install the #502217 short 4mm ball stud into the outer hole of the servo arm. Fasten the servo arm down with the stock mounting screw that came with your servo.
- 4 Snap one end of the ball cup onto the servo arm.

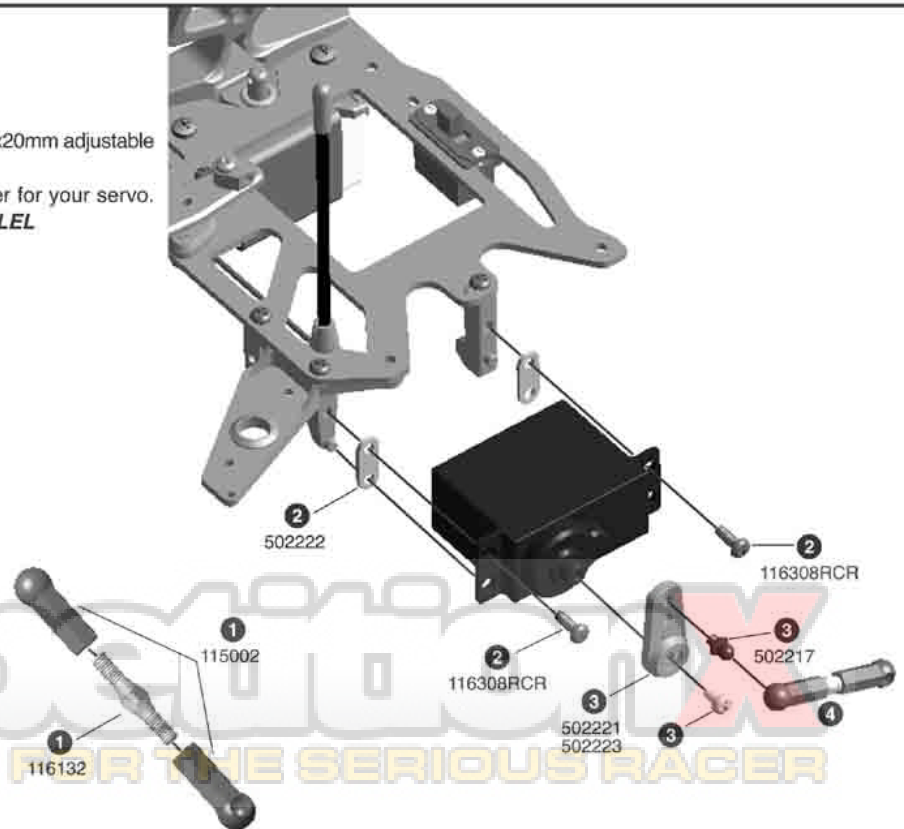

BAG L

 1:1 K1215-12, qty 1 30mm Push Type Clutch Collet	 1:1 116209, qty 2 3x4.8x0.1mm Shim (2)	 1:1 K1215-9, qty 1 7x13x0.3mm Washer	 1:1 K1215-6, qty 1 30mm Push Type Clutch Spring Adjusting Nut	 1:1 K1215-9, qty 1 5x9x0.1mm Washer	 1:1 K1146-14, qty 2 5x10mm Bearing	 1:1 116209, qty 2 3x4.8x0.3mm Shim (2)	 1:1 K1341-2, qty 1 30mm Push Type Clutch Spring (Silver)
 1:1 102622-3S, qty 4 3x8mm FH Screw	 1:1 126310C, qty 5 3x10mm Cap Screw	 1:1 K1146-15, qty 1 3x12mm Cap Screw	 1:1 K1146-11, qty 1 Thrust Bearing, 5x10mm	 1:1 102622-3S, qty 4 3x8mm FH Screw	 1:1 K1215-8, qty 1 30mm Push Type Clutch Set Thrust Bearing Retainer	 K1215-3, qty 1 30mm Push Type Clutch Shoe Plate	 K1146-2, qty 1 Push Type Clutch Nut
 K1215-2, qty 3 30mm Push Type Clutch Special Centrifugal Shoe.	 K1146-7, qty 1 Push Type Clutch Spring Cup	 K1413, qty 1 20T 1st Pinion Gear	 K1416, qty 1 24T 2nd Pinion Gear	 K1215-4, qty 1 30mm Push Type Clutch Shoe	 K1215-7, qty 1 G4 30mm Push Type Clutch Housing	 502241, qty 1 Engine Mount	 K1215-1, qty 1 30mm Push Type Clutch Flywheel

STEP 1

Please Read K1410 Instruction manual First

Flywheel Assembly

Please slide on the #K1215-12 collet (included) & #K1215-1 flywheel, tighten with the #K1146-2 clutch nut. The space between clutch nut top & shaft top is better around 9.5±0.1mm. The use of #K1215-9 7x13x0.3mm shims depends on the engine you use.

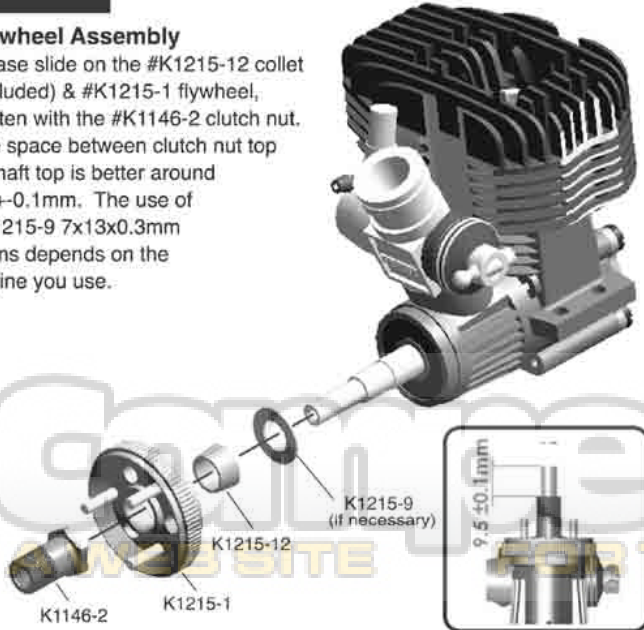

Add #116209 3x4.8mm shims to reach 9.5±0.1mm if necessary.

STEP 2

Clutch Shoe Assembly

Please slide on the #K1215-2 centrifugal shoes, #K1215-3 plate, #K1215-4 clutch shoe, K1146-7 spring cup & K1341-2 spring. Then, tighten the #K1215-6 clutch spring adjusting nut. The space between clutch nut top & spring adjusting nut top better starts with 0.5mm. The engagement timing is adjustable on the push type clutch set. If you rotate the adjusting nut clockwise, the clutch engages later.

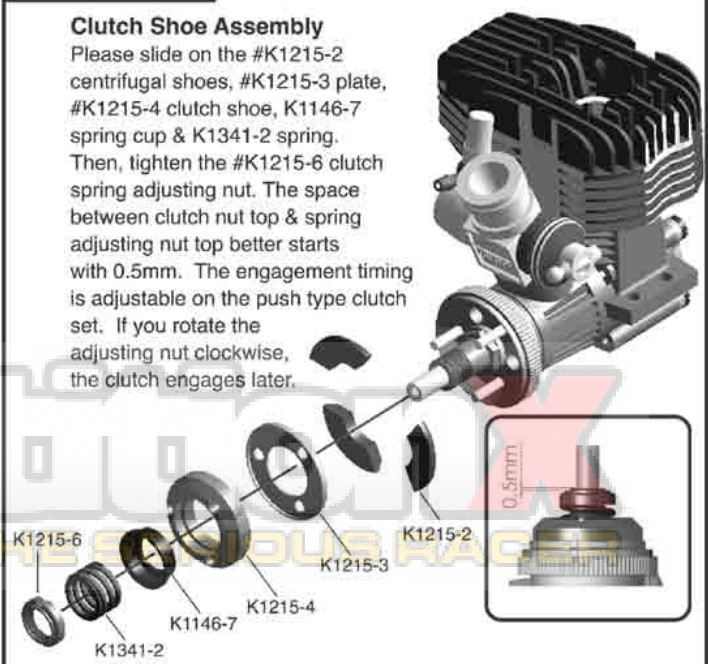

STEP 3

Clutch Housing Assembly

Please thread the #K1416 24T & K1413 20T pinion onto the #K1215-7 clutch housing (the 20T pinion shoulder should face inside). Slide on the #K1146-14 bearing, clutch housing, #K1146-14 bearing, #K1146-11 thrust bearing, #K1215-8 thrust bearing retainer & tighten down with the #K1146-15 cap screw. The use of #K1215-9 5x9x0.1mm shim depends on the engine you use.

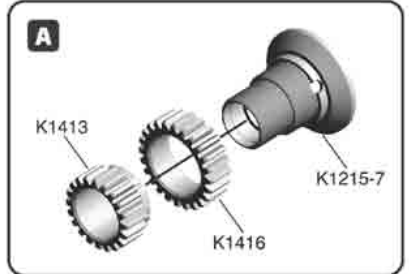
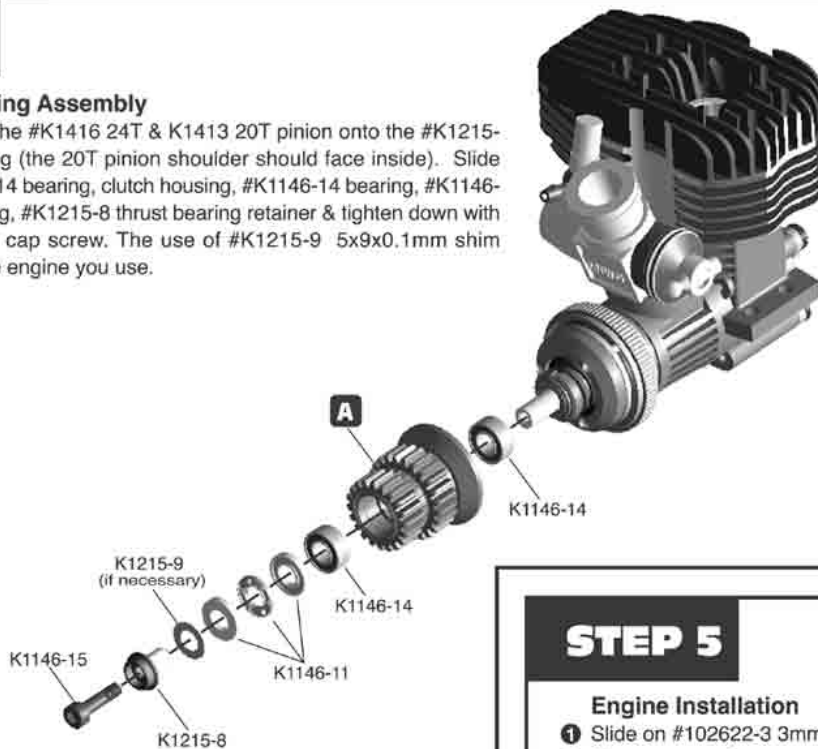

STEP 4

Engine Mount Assembly

Attach the #502241 engine mounts to your engine with 4 pcs #126310C 3x10mm cap screws.

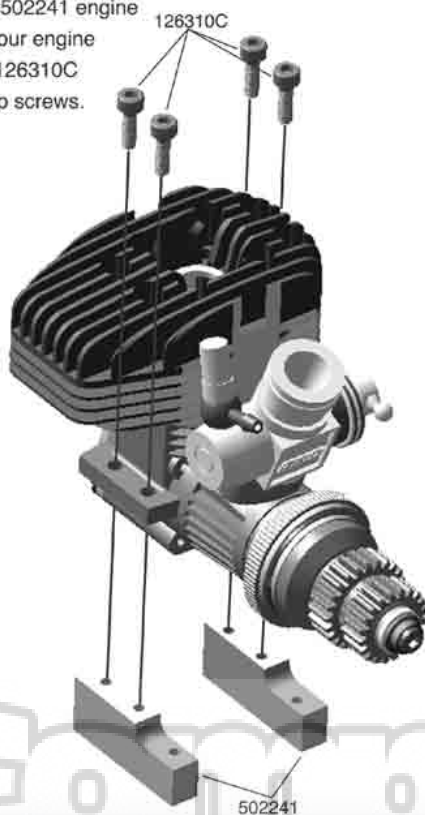

STEP 5

Engine Installation

- 1 Slide on #102622-3 3mm FH washers onto 3mm FH screws.
- 2 Place your engine assembly on top of the chassis. Attach the engine to the chassis with the above four screws. Do not tighten the screws yet.
- 3 Now we set the spur to pinion gear spacing, known as gear mesh. Make sure you can still slide your engine, then mesh the clutch bell pinions with the spur gears. The correct gear spacing is when the pinion is close to the spur gear, but if you hold the pinion gears, you should still be able to rock the spur gears back & forth slightly with light pressure. Roll the gears and check the mesh in several different locations on the spur gear. Now tighten the four motor screws. Recheck the mesh.

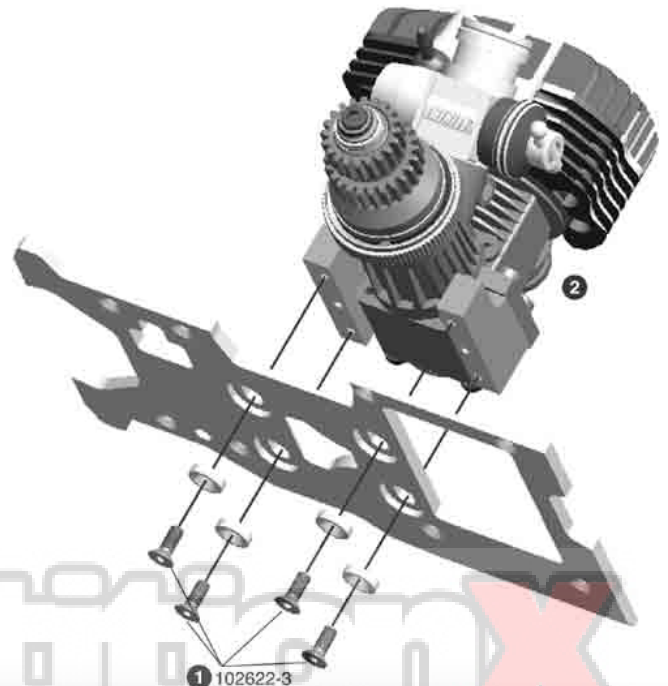













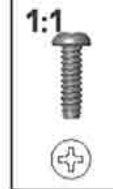















Optional Parts

K1412 G4 Hard Coated Alum. Light 19T Clutch Gear
 K1413 G4 Hard Coated Alum. Light 20T Clutch Gear
 K1414 G4 Hard Coated Alum. Light 21T Clutch Gear

K1415 G4 Hard Coated Alum. Light 23T Clutch Gear
 K1416 G4 Hard Coated Alum. Light 24T Clutch Gear
 K1417 G4 Hard Coated Alum. Light 25T Clutch Gear

BAG M

 116310CR, qty 12 3x10mm Cross FH TP Screw 07	 111050S, qty 1 3x6mm Cross FH Screw 06	 150612, qty 2 6x12x4mm Bearing 05	 116203, qty 2 E5 E-clip 15	 116201, qty 2 2x11mm Pin 08	 116310RCR, qty 1 3x10mm Cross RH TP Screw 02	 111050S, qty 1 3x3mm Set Screw 04	 111118, qty 2 R5 R-clip 03	 502217, qty 1 Short Ball Stud 03	
 502246, qty 1 Middle Mount M1	 502245, qty 1 Middle Shaft 05	 111050S, qty 1 Pipe Holder Mount M2	 502207, qty 1 18T Pulley Lid M1	 502207, qty 1 27T Pulley Gear M1	 502207, qty 1 27T Pulley Lid M1	 502222, qty 2 Servo Spacer 2.4mm K3	 502222, qty 2 Servo Spacer 1.2mm K3	 116308RCR, qty 3 3x8mm Cross RH TP Screw 05	 116312RCR, qty 1 3x12mm Cross RH TP Screw 05
 502213, qty 1 Receiver Mount M3	 116205, qty 1 Double Side Tape K5	 502248, qty 1 Side Belt E1	 111050S, qty 1 Pipe Holder Spring M2	 502217, qty 1 Fixed Linkage Rod M3	 502247, qty 1 Fuel Tank M5	 502221, qty 1 Servo Arm (Futaba) K1	 502223, qty 1 Servo Arm (Ko, Sanwa & JR) K1	 502219, qty 1 Steering Servo Mount M3	 502207, qty 1 18T Pulley Gear M1

STEP 1

Pulley Assembly

- 1 Attach the #502207 18T pulley lid to the 18T pulley gear.
- 2 Attach the #502207 27T pulley lid to the 27T pulley gear.

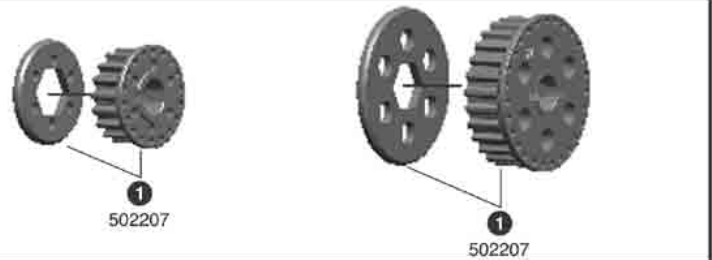

STEP 2

Middle Mount Assembly

- 1 Install a #150612 6x12x4mm bearing on both sides of the #502246 middle mount.
- 2 Install & center a #116201 2x11mm pin into the #502245 middle shaft.
- 3 Slide the #502207 27T pulley onto the middle shaft & add a #116203 E5 E-clip.
- 4 Slide the middle shaft assembly through the middle mount.
- 5 Install & center a #116201 2x11mm pin into the #502245 middle shaft.
- 6 Slide the #502207 18T pulley onto the middle shaft & add a #116203 E5 E-clip.

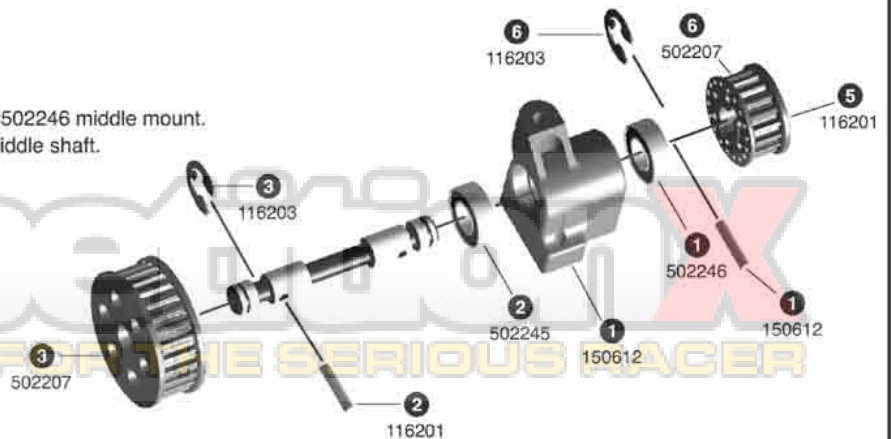

STEP 3

Middle Mount Installation

- 1 Attach the #111050S pipe holder mount to the chassis with a 3x6mm cross FH screw. Please have the pipe spring hole facing outside.
- 2 Attach the middle mount assembly to the chassis with 2pcs #116310CR 3x10mm cross FH screws.

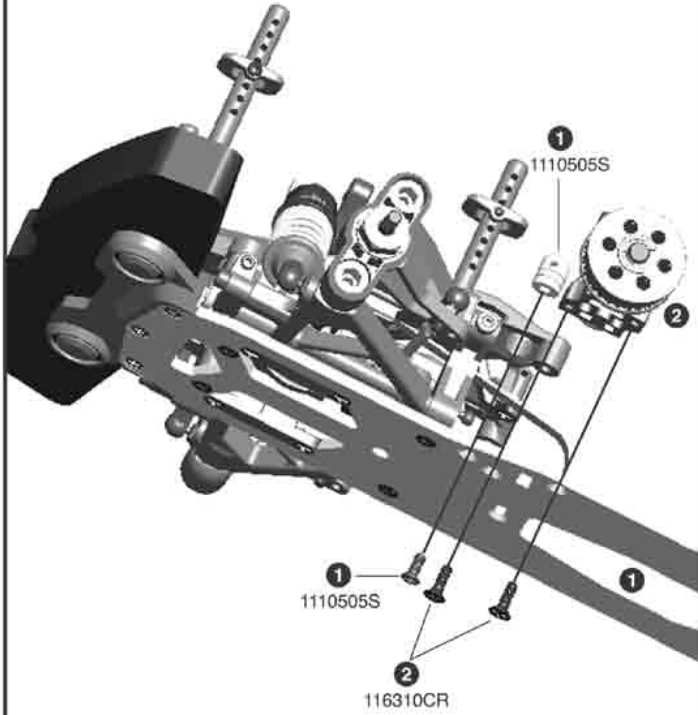

STEP 4

Rear Suspension System Installation

- 1 Attach the rear suspension assembly to the chassis with 8pcs #116310CR 3x10mm cross FH TP screws.

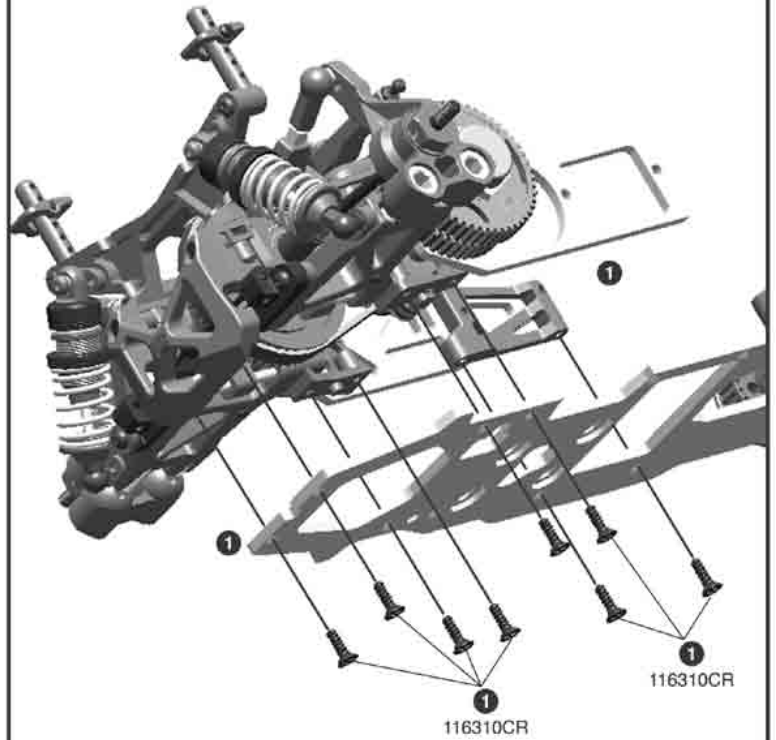

STEP 5

Radio Plate Installation

- 1 Attach the radio plate assembly to the chassis with 3pcs #116310CR 3x10mm cross FH TP screws.
- 2 Attach the #502213 receiver mount to the alum. side plate with 2pcs 116310RCR 3x10mm cross RH TP screws for the bottom.
- 3 Detach front upper stiffener assembly for easy installation if necessary.

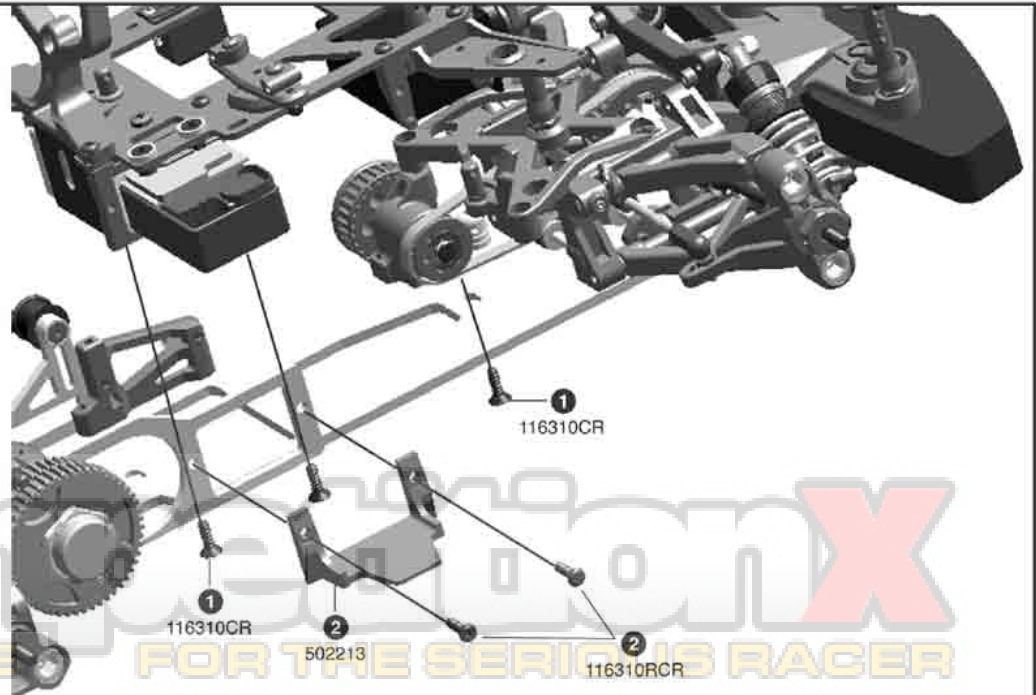

STEP 6

Throttle Servo & Fuel Tank Installation

- 1 Attach the #502219 throttle servo mount to the radio plate with a #116308RCR 3x8mm cross RH TP screw.
- 2 Find the appropriate thick or thin #502222 servo spacer for your servo. **THE THROTTLE LINKAGE ROD SHOULD BE PARALLEL TO THE CHASSIS WHEN CONNECTING TO THE THROTTLE LINKAGE ARM.** Attach the spacer if any, in between the #502219 servo mount & steering servo with the #116308RCR 3x8mm cross RH TP screws.
- 3 Find the appropriate #502221 or #502223 servo arm for your throttle servo. Install the #502217 short 4mm ball stud into the servo arm. Fasten the servo arm down with the stock mounting screw that came with your servo.
- 4 Snap one end of the #502217 fixed rod onto the servo arm ball stud & the other end on the throttle linkage arm ball stud.
- 5 **SNAP THE OTHER END OF THE STEERING LINKAGE ROD BALL CUP ONTO THE SERVO SAVER BALL STUD.**
- 6 Install a #116312RCR 3x12mm cross RH TP screw.
- 7 Install 2pcs #116310CR 3x10mm FH TP screws.
- 8 Install #502247 fuel tank & slide in #111118 R5 R-clips to hold it in place.

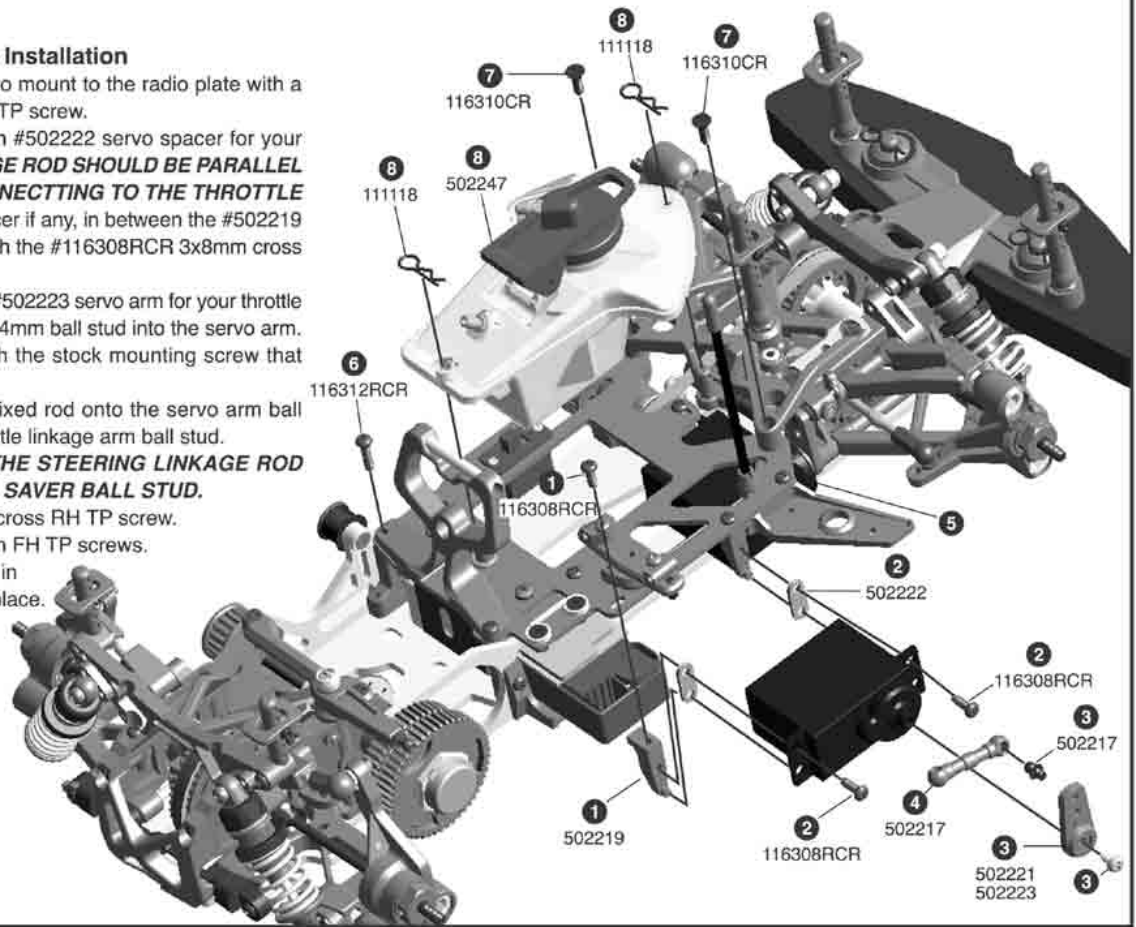

STEP 7

- 1 Slip the #502248 middle belt onto the two pulleys.
- 2 Attach the rear exhaust manifold to your engine with manifold spring.
- 3 Slide the #111050S spring into the muffler & secure it with a 4x4mm set screw.
- 4 Attach the other end of the spring to the pipe holder mount with a 3x3mm set screw.

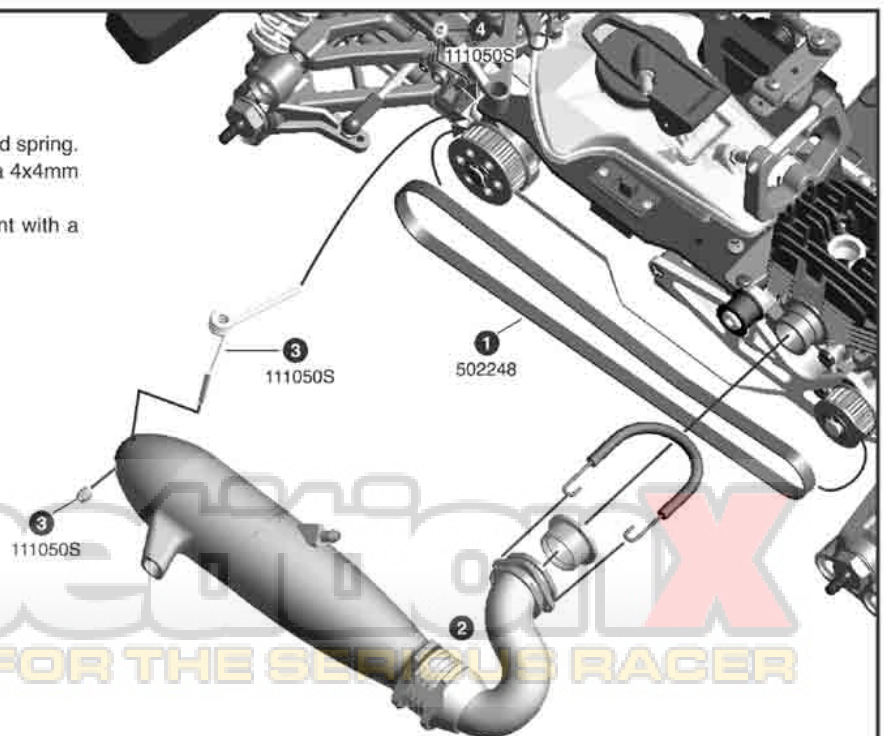

COMPETITORS
A WEB SITE FOR THE SERIOUS RACER

BAG N

1:1



111040B, qty 4
Alum. 4mm
Flanged Nut

01

1:1



115023BK, qty 2
Throttle Ball Cup

03

1:1



117001S, qty 4
3x3mm Set Screw

04

1:1



117001S, qty 4
Collar

02

1:1



116207, qty 1
Throttle/Brake
Spring

03



116208, qty 2
Throttle/Brake
Linkage Rod

04



119001SK, qty 1
Fuel Tube

05

STEP 1

Wheel Installation

- 1 Slide the tires over the axle and tighten it down with a #111040B 4mm flanged locknut.
- 2 Install the remaining 3pcs tires.

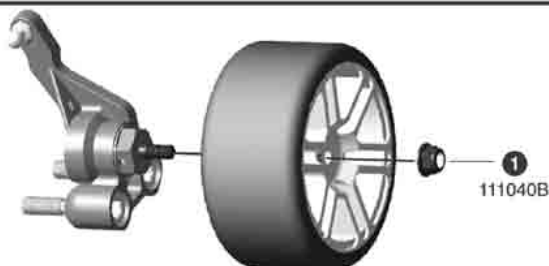

STEP 2

Throttle & Brake Linkage

- 1 **MAKE SURE YOUR SERVO IN THE NEUTRAL POSITION.** Thread a #115023BK throttle ball cup onto the end of the #116208 linkage rod. Slide on a #117001S collar & attach it 12mm from the end of the throttle ball cup with one 3x3mm set screw. Slide one #116207 throttle spring onto the rod. Slide the throttle rod through the throttle pivot. Snap the #115023BK throttle ball cup onto the engine carburetor ball stud. **PUSH THE ROD TO CLOSE THE CARBURETOR.** Attach the second #117001S collar to the end with a 3x3mm set screw. There should have tension on the spring. This will keep the carburetor in the idle position. Just cut off the remaining part of the throttle rod, leaving 10mm length protruding so you can adjust your throttle linkage.
- 2 Thread a #115023BK ball cup onto the end of the #116208 linkage rod. Slide the brake rod through the brake pivot. Snap the #115023BK ball cup onto the brake lever ball stud. Cut approx. 1cm #119001SK silicone fuel tube. Slide the silicone tube on the rod & attach a #117001S collar with 3x3mm set screw. **THE BRAKE SHOULD NOT BE APPLIED WHEN THE THROTTLE IS AT IDLE.**
- 3 Cut one piece of fuel tube 10cm long. Slide one end of the fuel tube onto the fuel fitting on your engine. Run the fuel tube along the side of the air filter mount & place the other end into the fuel inlet of the fuel tank.
- 4 Cut one second piece of fuel tube 10cm long. Slide one end into the pressure fitting of the pipe. Place the other end of tube into the second inlet on the fuel tank cover.
- 5 Secure the air filter (not included) with a wire tie.

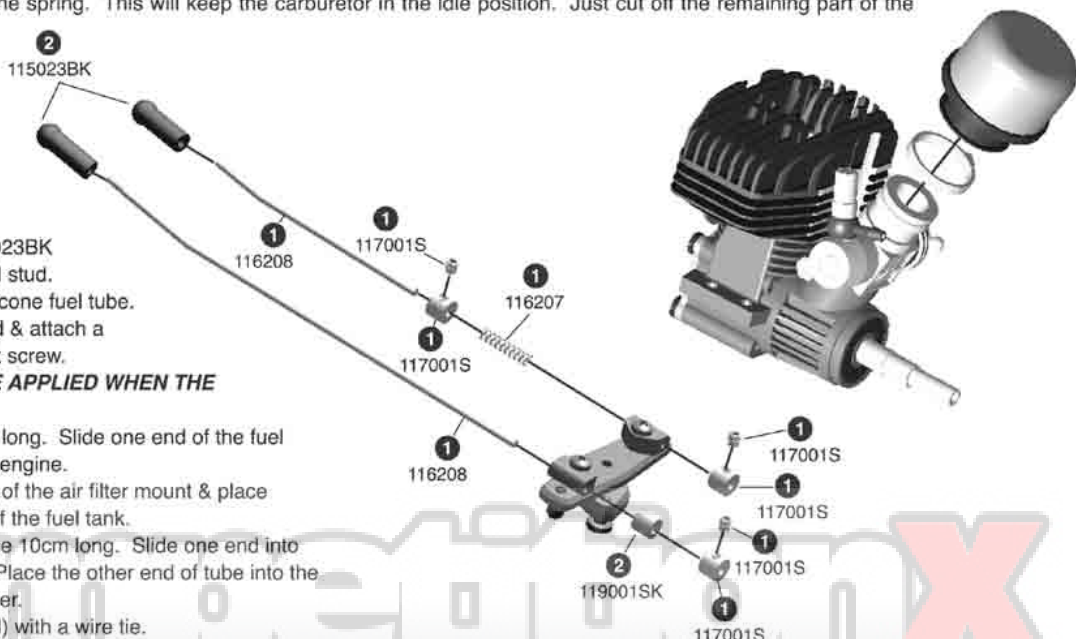

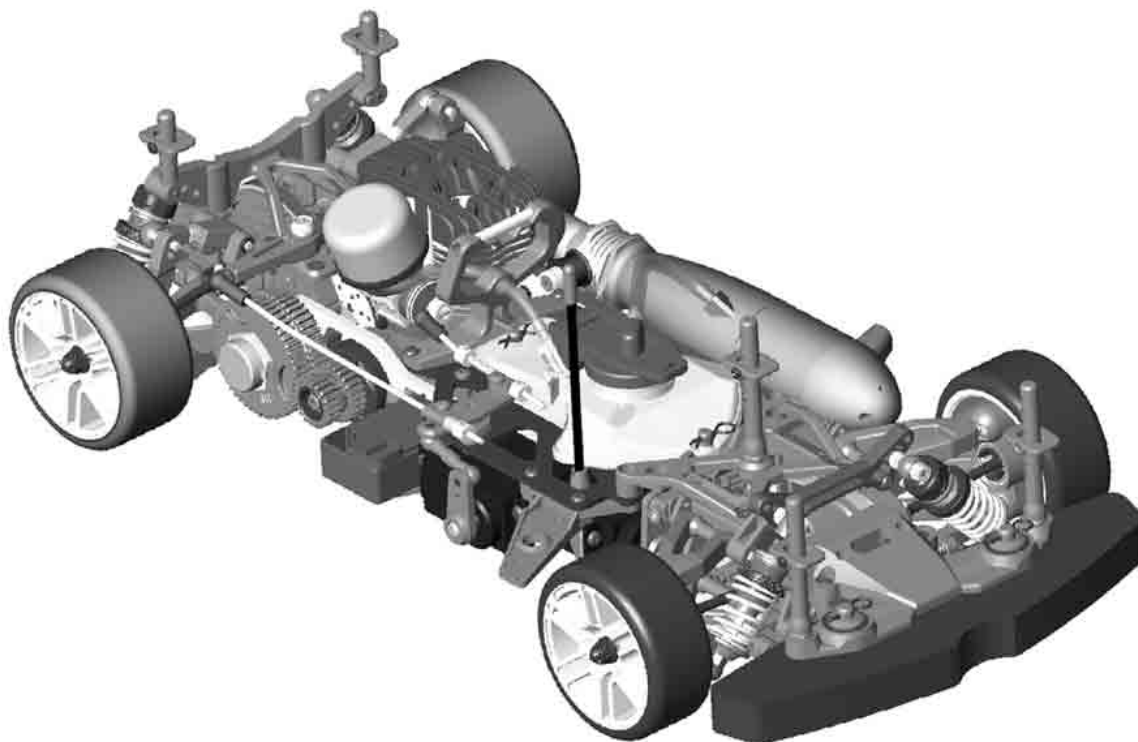

Final Adjustments

Two Speed Adjustment

By increasing or decrease the spring tension you can change the shift point of your two speed. If you want the car to shift into second gear earlier, screw out both screws equally 1/4 turn to decrease the sprint tension, and vice verse. Run your car first before you make any adjustments to the two speed.

To adjust your 2 speed (please turn off your engine):

Lift the car and hold the spur gear in place, the 2 speed housing facing up.

Turn the rear tire slowly.

Watch for the 2 speed screw to appear in the opening of 2 speed housing.

Insert your Allen wrench and adjust as needed.

Remove the Allen wrench and turn the rear tire again and repeat for the second 2 speed screw, adjusting it the same mount.

Droop

Droop can be adjusted on the G4 to help speed up or slow down how fast the car changes direction when corning. If the track is bumpy, you may want to add droop to your car by going to a lower number. For example, from 4mm to 3mm. If the track has very high traction, you may want to decrease droop by going to a higher number. For example, from 4mm to 5mm.

Camber

Camber describes the angle the wheels relative to the ground when looked at from the front or rear. Negative camber means that the tire leans inward at the top.

Front Toe-In

Front Toe-In can make your car easier to drive. Toe-Out will increase steering when entering corners, but will be slightly more difficult to drive.

Rear Toe-In

Decreasing the rear toe you will decrease rear traction and add steering.

TRACK CONDITIONS

Date: _____ Driver: _____
 Event: _____ Car: _____
 Track: _____ Weight: _____ g

Surface: _____ Smooth _____ Med. _____ Bumpy
 Size: _____ Open _____ Med. _____ Tight
 Traction: _____ High _____ Med. _____ Low
 Track Temp / Air Temp: _____ ° / _____ °
 Note: _____

FRONT SUSPENSION

Front Droop: 2 mm

Front Camber (Left) 3 ° / (Right) 3 °

Front Ride Height: 4.5 mm

Toe Angle: + 0 ° / - 0 °

Anti-Roll Bar: 0 ° (E-class)
 Diff. Fluid: #30000 wt (C-class)
 One-Way: (E-class)

Steering: _____
 Caster: 4 mm

199 mm Front Width

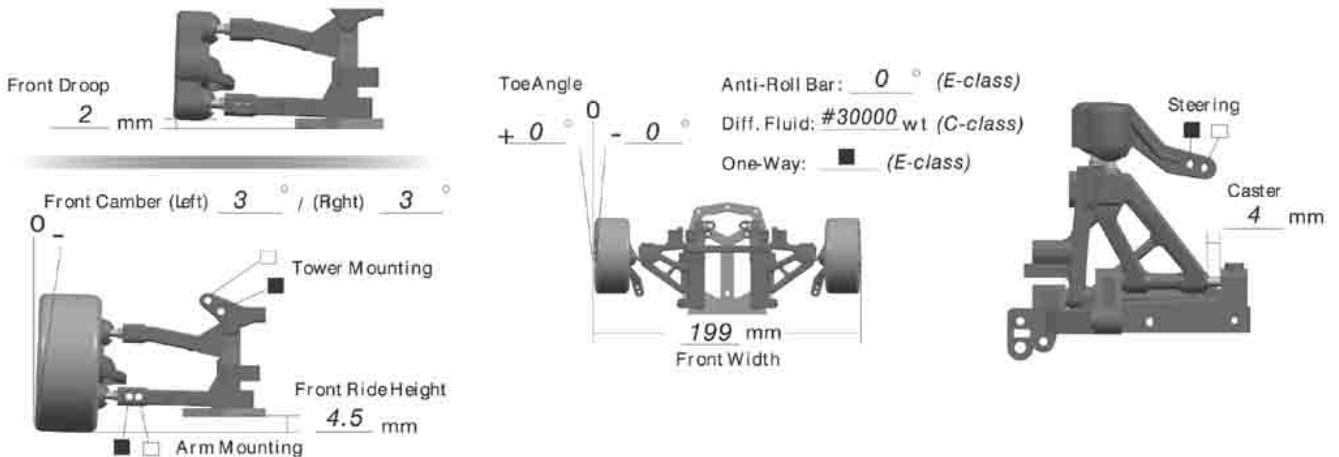

REAR SUSPENSION

Rear Droop: 4 mm

Rear Camber (Left) 5 ° / (Right) 5 °

Rear Ride Height: 5 mm

Toe Angle: 0 / - 2 °

Anti-Roll Bar: _____ °
 Diff. Fluid: 1/2#30000+1/2#600 wt
 Solid Axle: _____

Camber Link: _____
 Tower Mounting: _____
 Arm Mounting: _____

200 mm Rear Width

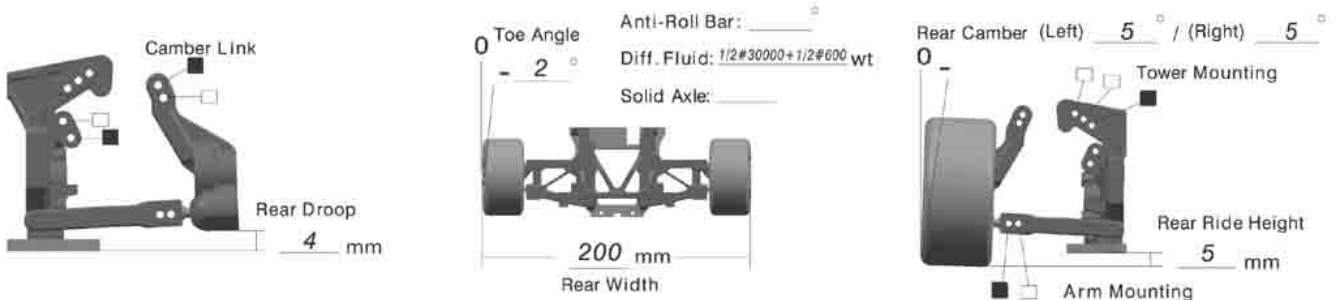

ENGINE

Clutch Set Type: 20 t / 51 t
 _____ 3 Shoe / 24 t / 47 t

Clutch Spring: _____ mm

Clutch Weight: _____

Clutch Shoe: _____

Engine: _____
 Plug: _____
 Fuel: _____
 Manifold: _____
 Pipe: _____
 Notes: _____

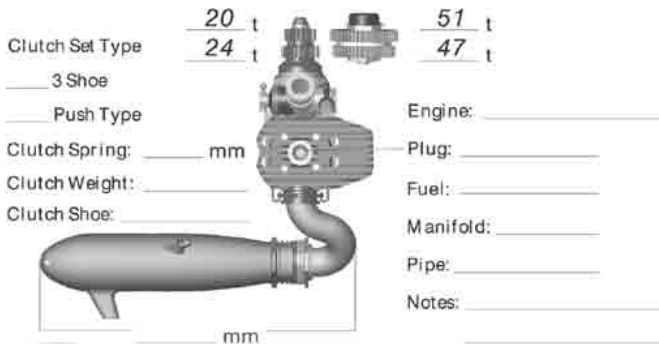

Front Oil: #600 / #600 wt
 Rear Oil: #600 / #600 wt

Front Spring: 63.5 / 63.5 mm
 Rear Spring: _____ / _____ mm

Piston: std. / std.

Front Spring: std. / std. mm
 Rear Spring: _____ / _____ mm



Front Tire: GRP

Shore: Left 45 ° / Right 45 °

Rear Tire: GRP

Shore: Left 42 ° / Right 42 °

Diameter (Start): Left 64 / Right 64 mm
 Diameter (Finish): _____ / _____ mm

Diameter (Start): Left 64 / Right 64 mm
 Diameter (Finish): _____ / _____ mm

COMMENTS

Lap / Race Time: _____

Best Lap Time: _____

Position: _____

Notes: _____

Body: _____

Radio: _____

ST. Servo: _____

TH. Servo: _____



TRACK CONDITIONS

Date: _____ Driver: _____
 Event: _____ Car: _____
 Track: _____ Weight: _____ g

Surface: _____ Smooth _____ Med. _____ Bumpy
 Size: _____ Open _____ Med. _____ Tight
 Traction: _____ High _____ Med. _____ Low
 Track Temp / Air Temp: _____ ° / _____ °
 Note: _____

FRONT SUSPENSION

Front Droop _____ mm



Front Camber (Left) _____ ° / (Right) _____ °

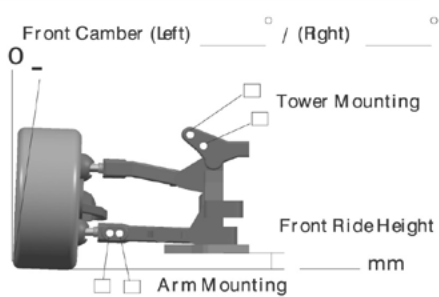

Tower Mounting

Front Ride Height _____ mm

Arm Mounting

Toe Angle _____ °

Anti-Roll Bar: _____ °

Diff. Fluid: _____ wt

One-Way: _____

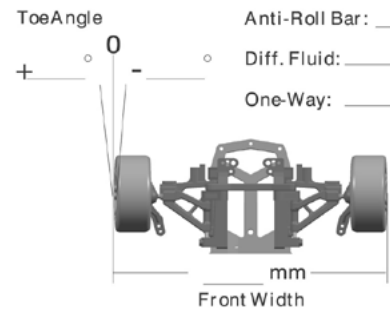

mm

Front Width

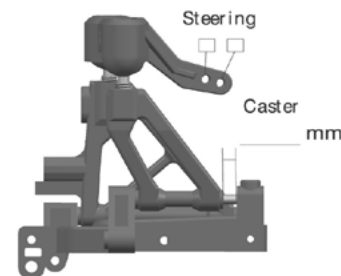

Steering

Caster _____ mm

REAR SUSPENSION

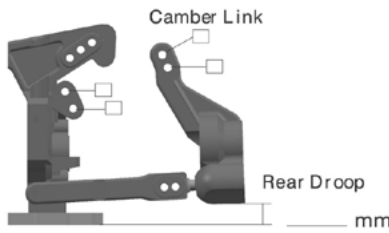

Camber Link

Rear Droop _____ mm

Toe Angle _____ °

Anti-Roll Bar: _____ °

Diff. Fluid: _____ wt

Solid Axle: _____

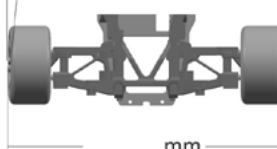

mm

Rear Width

Rear Camber (Left) _____ ° / (Right) _____ °

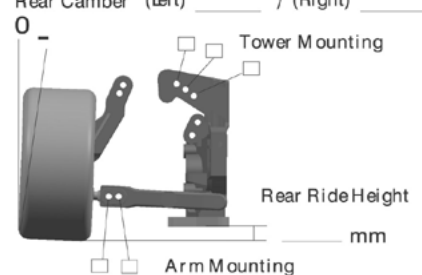

Tower Mounting

Rear Ride Height _____ mm

Arm Mounting

ENGINE

Clutch Set Type _____ t _____ t
 _____ 3 Shoe
 _____ Push Type

Clutch Spring: _____ mm

Clutch Weight: _____

Clutch Shoe: _____

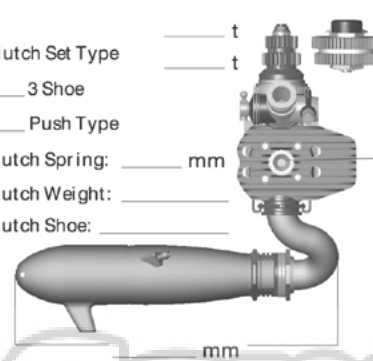

Engine: _____

Plug: _____

Fuel: _____

Manifold: _____

Pipe: _____

Notes: _____

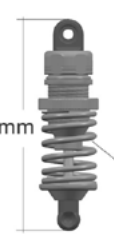

Front _____ Rear _____

Oil: _____ / _____ wt

Piston: _____ / _____

Spring Front _____ Rear _____

mm

Front Tire: _____

Left _____ Right _____

Shore: _____ / _____

Diameter (Start) _____ / _____ mm

Diameter (Finish) _____ / _____ mm

Rear Tire: _____

Left _____ Right _____

Shore: _____ / _____

Diameter (Start) _____ / _____ mm

Diameter (Finish) _____ / _____ mm

COMMENTS

Lap / Race Time: _____

Best Lap Time: _____

Position: _____

Notes: _____



Body: _____

Radio: _____

ST. Servo: _____

TH. Servo: _____



Team Magic G4 Parts List

102622-3	3mm F.H. Screw & Washer (4)	502103	G4 2 Speed Shoe Spring & Screw (2)
111003	3mm Alum. F.H. Washer (6)	502104	G4 2 Speed 2nd Spur Gear 46T
111007F	3mm Flat Locknut (10)	502105	G4 2 Speed 2nd Spur Gear 47T
111007ST	3mm Steel Locknut (10)	502106	G4 2 Speed 2nd Spur Gear 48T
111040	4mm Alum. Flanged Lock Nut (4)	502107	G4 2 Speed 1st Spur Gear 50T
111041	3mm Alum. Cap Washer (6)	502108	G4 2 Speed 1st Spur Gear 51T
111050	Pipe Holder (3mm)	502109	G4 2 Speed 1st Spur Gear 52T
111118	R5 R-clip (10)	502110	G4 2 Speed Housing & Nut (w/bearing)
111120	R6 R-clip (10)	502111	G4 One Way Hub & Nut (w/bearing)
115001	Ball End & Flanged Steel Ball (6)	502115	G4 Diff Case (2), Diff Case Cover (1) & Gasket (2)
115002	4mm Ball Stud & Ball Cup (for 3mm rod)(6)	502116	G4 Diff Joint, P5 O-ring, 5x12mm Shim & 2x11mm Pin (2)
115016	Antenna Rod (2)	502117	G4 4x10mm Shim, Bevel Shaft & Bevel Gear Set (1 set)
115021	4.8mm Ball Stud & Ball Cup (for 4mm rod) (6)	502118	G4 Diff Case Gasket (4)
115022	4mm Ball Stud & Shock Ball Cup (6)	502120	G4 Nylon Front Pulley Set (w/screw)
115023	Throttle Ball Cup (4)	502122	G4 Nylon Rear Pulley Set (w/screw)
116042	Allen Wrench Set (1.5, 2.0, 2.5 & 5mm)	502124	#30000 Silicone Oil
116043	Cross Wrench (4, 5, 5.5 & 7mm)	502125	#600 Silicone Oil
116132	3x20mm Adjustable Rod (2)	502127	G4 Shock Cap Set (2)
116134-5	3x45mm Adjustable Rod (2)	502128	G4 Hard Coated Threaded Shock Body Set (2)
116201	2x11mm Pin (10)	502129	G4 P3 O-ring (4), Washer (4) & G-clip (4)
116202	E-clip 2.5 (10)	502130	G4 Shock Shaft & Piston Set (2)
116203	E-clip 5 (10)	502131	G4 Membrane (4)
116204	7x13x0.1mm (3), 7x13x0.3mm (2) & 7x13x0.5mm Shim (1)	502134	G4 Shock Spring Cup (4)
116205	Double Side Tape	502135	Shock Spring 1.2mm (2)
116206	2x10mm Pin (10)	502136	Shock Spring 1.3mm (2)
116207	Throttle/Brake Linkage Spring (4)	502137	Shock Spring 1.4mm (2)
116208	Throttle/Brake Linkage Rod (4)	502138	Shock Spring 1.5mm (2)
116209	3x4.8x0.1mm (5) & 3x4.8x0.3mm Shim (5)	502139	Shock Spring 1.6mm (2)
116211	Drive Shaft Cushion O-ring (8)	502140	Shock Spring 1.7mm (2)
116306BDCR	3x6mm Steel BDH TP Screw	502141	Shock Spring 1.8mm (2)
116308CR	3x8mm Steel FH TP Screw (cross) (6)	502142	Shock Spring 1.9mm (2)
116310RCR	3x10mm Steel RH TP Screw (cross) (6)	502143	Shock Spring Set (8 pairs)
116310CR	3x10mm Steel FH TP Screw (cross) (6)	502144	G4 Stock Shock Spring (2)
116312RCR	3x12mm Steel RH TP Screw (cross) (6)	502150	G4 Steering Block (L & R)
117001	Alum. Stopper (4)	502151	G4 9mm Low Friction Pivot Ball (2)
119001	Silicone Fuel Tube (60cm)	502152	G4 9mm Pivot Ball Nut (2)
126305S	3x5mm Set Screw (6)	502153	G4 Wheel Axle (2)
126306RCR	3x6mm Steel RH Screw (cross) (6)	502154	G4 Hex Wheel Adapter (4)
126308CR	3x8mm Steel FH Screw (cross) (6)	502155	G4 Rear Hub Carrier (L & R)
126310	3x10mm Steel F.H. Screw (6)	502160	G4 Front Lower Arm & Up/Down Stop Mount
126310C	3x10mm Cap Screw (6)	502161	G4 Front Upper Arm
126312C	3x12mm Cap Screw (6)	502162	G4 Sliding Steering Servo Saver Set
126314BU	3x14mm Button Head Screw (6)	502163	G4 Front Bulkhead
126320C	3x20mm Cap Screw (6)	502164	G4 Front Diff Mount
126408S	4x8mm Set Screw (6)	502165	G4 Sliding Steering Rail Mount & Screw
150508	5x8x2.5mm Bearing (2)	502170	G4 Sliding Steering Rail (2)
150508F	5x8mm Flanged Bearing (2)	502171	G4 Front Belt
150510	5x10x4mm Dust-Resistant Bearing (4)	502172	G4 Nylon Front Upper Stiffener Bracket
150511	5x11x4mm Dust-Resistant Bearing (4)	502173	G4 5th Body Post Set
150610	6x10x3mm Bearing (2)	502174	G4 Fuel Tank Supporter & Handle
150612	6x12x4mm Bearing (4)	502175	G4 Front Shock Tower
151015	10x15x4mm Bearing (4)	502176	G4 Drive Shaft (2)
151218	12x18x4mm Bearing (4)	502179	G4 Caster Clip Set
181603	3 Shoe Teflon Clutch Shoe (3)	502180	G4 Front Lower Arm Stiffener Brace
181607	3 Shoe Clutch Spring (3)	502183	G4 Front Body Post (2)
502001	1/10 G4 Gas Touring Car (C-class) (Dodge Stratus 2.1)	502184	G4 Front Lower Bumper
502002	1/10 G4 Gas Touring Car (C-class) (Acura RSX)	502185	G4 Front Upper Bumper
502051	1/10 G4 Gas Touring Car (E-class) (Dodge Stratus 2.1)	502186	G4 Bumper Foam Post Set (2)
502052	1/10 G4 Gas Touring Car (E-class) (Acura RSX)	502187	G4 3mm Chassis
502101	G4 2 Speed Shoe Cam & Posts	502188	G4 Foam Bumper
502102	G4 2 Speed Shoe (2)	502190	G4 Rear Shock Tower

Team Magic G4 Parts List

502191	G4 Rear Body Post Set (2)
502192	G4 4x18mm Alum. Adjustable Rod (2)
502193	G4 Rear Upper Link Nylon Parts (2)
502196	G4 Rear Bulkhead, Brake Bracket & Back Bracket
502197	G4 Brake Cam & Lever Set
502198	G4 Brake Plate & Brake Pad
502199	G4 Alum. Side Plate (2)
502200	G4 Lightweight 2 Speed Shaft
502201	G4 Brake Disc Set
502202	G4 19T Brake Pulley
502203	G4 2 Speed Housing Dust Cover
502206	G4 Rear Belt
502207	G4 18T, 19T & 27T Pulley
502208	G4 Rear Lower Arm Set
502211	G4 Belt Tensioner
502213	G4 Radio Plate Support & Receiver Support
502216	G4 Alum. Radio Plate
502217	G4 Throttle Linkage Set
502219	G4 Servo & Transponder Mount Set
502220	G4 Receiver Battery Mount
502221	G4 Servo Arm (Futaba) (2)
502222	G4 Servo Spacer (4)
502223	G4 Servo Arm (Ko, Sanwa & JR) (2)
502225	G4 3 Shoe Flywheel & Collet
502227	G4 Standard Clutch Nut
502228	G4 SG Clutch Nut
502229	G4 3 Shoe 2 Speed Clutch Bell
502241	G4 Engine Mount
502245	G4 Middle Shaft
502246	G4 Middle Belt Mount
502247	G4 Fuel Tank
502248	G4 Side Belt
502301	G4 2 Speed Shoe Set
502302	G4 Diff Case & Pulley Set
502303	G4 Shock (2)
502304	G4 Wheel Axle (2) & Adapter (4)
502305	G4 Front Arm Set
502306	G4 Sliding Servo Saver, Rail & Mount
502307	G4 Nylon FR UP Bracket, 5th Post & Handle
502308	G4 Front & Rear Shock Tower
502309	G4 Front & Rear Body Post
502310	G4 FR Upper & Lower Bumper & Posts
502311	G4 Rear Arm Set
502312	G4 Pulley Set
502313	G4 Radio Plate, Receiver, Servo & Battery Mount
502314	G4 Throttle Servo Linkage Set
502315	G4 Differential Set

K1146-2	Push Type Clutch Nut
K1146-7	Push Type Clutch Spring Cup
K1146-11	Thrust Bearing, 5x10mm
K1146-14	5x10mm Bearing (2)
K1146-15	3x12mm Cap Screw (2)
K1215-1	30mm Push Type Clutch Flywheel
K1215-2	30mm Push Type Clutch Special Centrifugal Shoe (3)
K1215-3	30mm Push Type Clutch Shoe Plate
K1215-4	30mm Push Type Clutch Shoe
K1215-6	30mm Push Type Clutch Spring Adjusting Nut
K1215-7	G4 & NTC3 30mm Push Type Clutch Housing
K1215-8	30mm Push Type Clutch Set Thrust Bearing Retainer
K1215-9	30mm Push Type Clutch Set Clearance Shim (7)
K1215-12	30mm Push Type Clutch Collet
K1341-2	30mm Push Type Clutch Spring (Silver)
K1406	G4 Alum. Front Anti-Roll Bar Mounts (w/anti-roll bar)
K1407	G4 Alum. Rear Anti-Roll Bar Mounts (w/anti-roll bar)
K1408	G4 Carbon Radio Plate
K1409	G4 & V1 Lightweight Front One-Way
K1410	G4 Hard Coated 30mm Push Type Clutch Set
K1412	G4 Hard Coated Alum. Light 19T Clutch Gear
K1413	G4 Hard Coated Alum. Light 20T Clutch Gear
K1414	G4 Hard Coated Alum. Light 21T Clutch Gear
K1415	G4 Hard Coated Alum. Light 23T Clutch Gear
K1416	G4 Hard Coated Alum. Light 24T Clutch Gear
K1417	G4 Hard Coated Alum. Light 25T Clutch Gear
K1463	G4 Super Hardened Hinge Pin (Front Upper) (2)
K1464	G4 Super Hardened Hinge Pin (Front Lower) (2)
K1465	G4 Super Hardened Hinge Pin (Rear Upper) (2)
K1466	G4 Super Hardened Hinge Pin (Rear Lower) (2)



Team Magic Model Industrial Co. Ltd.

Tel:886-4-23552606

Fax:886-4-23552946

E-Mail: service@teammagic.com.tw

Web Site: www.teammagic.com.tw

CompetitionX
A WEB SITE FOR THE SERIOUS RACER