

**(IT) Attenzione:** Istruzioni di montaggio per barre in ferro.  
**(GB) Attention:** Mounting instructions for steel bar carriers.  
**(E) Atención:** Instrucciones de montaje para barras portatodo en hierro.  
**(D) Achtung:** Montageanweisungen für Stahl-Lastenträger.  
**(F) Attention:** Notices de montage pour barres de portage en métal.  
**(NL) Attentie:** Handleiding voor dakdragers gemaakt van ijzer.  
**(P) Atenção:** Instrukções de montagem para barras de tejadilho em ferro.  
**(H) Szerelési utasítások** acél tartórudakhoz.  
**(PL) Uwaga:** Instrukcja montażu bagażników wykonanych ze stali.  
**(SLO) Pozor:** Navodila za montažo nosilcev prtljačnika -čeleznih.  
**(HR) Uputstvo za** montažu čeljeznih krovnih nosača.

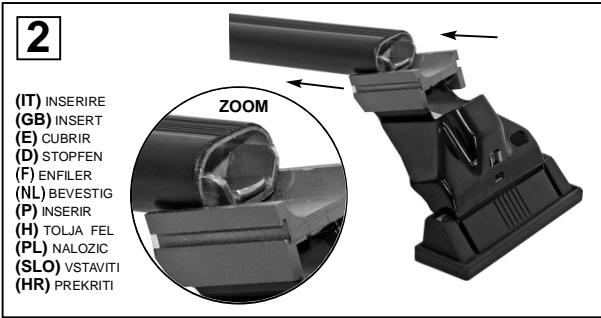

**3**

	<b>(IT) MODELLI AUTO</b> <b>(GB) CARS</b> <b>(E) COCHES</b> <b>(D) WAGEN</b> <b>(F) VOITURES</b>	<b>(NL) AUTO</b> <b>(P) MODELO AUTO</b> <b>(H) AUTO TIPIJS</b> <b>(SLO) MODELI AVTOMOBILOV</b> <b>(HR) MODELI AUTA</b>
	<b>(IT) ANTERIORE</b> <b>(GB) FRONT</b> <b>(E) DELANTERO</b> <b>(D) VORDERE</b> <b>(F) AVANT</b>	<b>(NL) VOORSTEG.</b> <b>(P) R FRENTE</b> <b>(H) ELSŐ RÜD</b> <b>(PL) PRZOD</b> <b>(SLO) SPREDAJ</b> <b>(HR) PREDNJI</b>
	<b>(IT) POST.</b> <b>(GB) REAR</b> <b>(E) TRASERO</b> <b>(D) HINTERE</b> <b>(F) ARRIERE</b>	<b>(NL) ACHTERSTE G.</b> <b>(P) ATRAS</b> <b>(H) HÁTSÓ RÜD</b> <b>(PL) TYŁ</b> <b>(SLO) ZADAJ</b> <b>(HR) STRAČNJI</b>
<b>CHEVROLET AVEO 4p. (06-&gt;11)</b>	<b>87 mm.</b>	<b>103 mm.</b>
<b>CHEVROLET LACETTI 4-5 p. (03-&gt;08)</b>	<b>65 mm.</b>	<b>81 mm.</b>
<b>DAIHATSU TREVIS</b>	<b>172 mm.</b>	<b>172 mm.</b>
<b>NEW DAEWOO NUBIRA (03-&gt;)</b>	<b>87 mm.</b>	<b>103 mm.</b>
<b>OPEL AGILA NO RAILS (-&gt;07)</b>	<b>115 mm.</b>	<b>125 mm.</b>
<b>SUZUKI WAGON R NO RAILS</b>	<b>115 mm.</b>	<b>125 mm.</b>

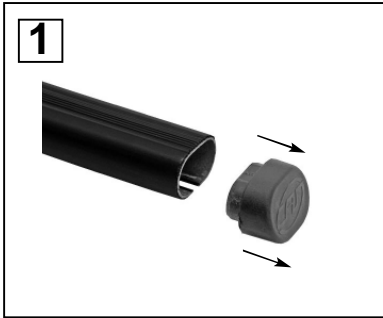
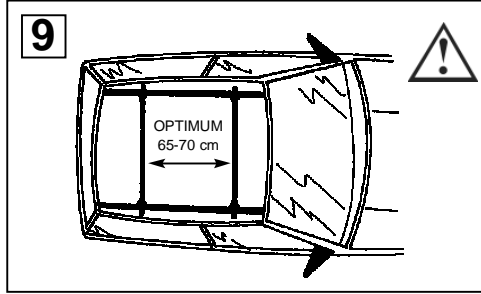
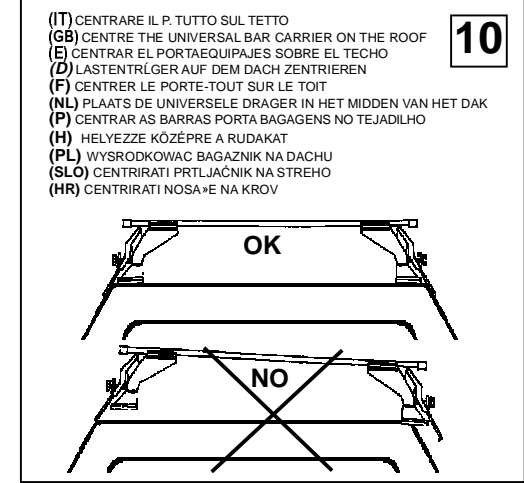
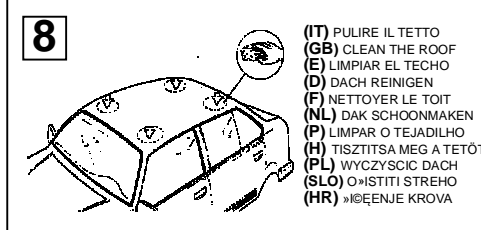
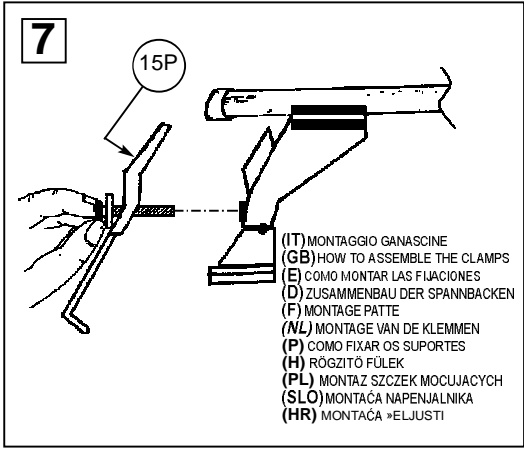
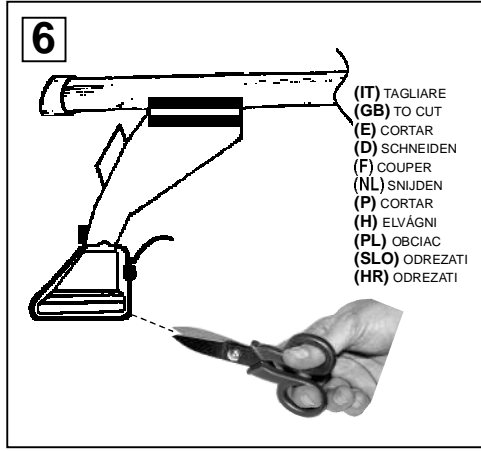
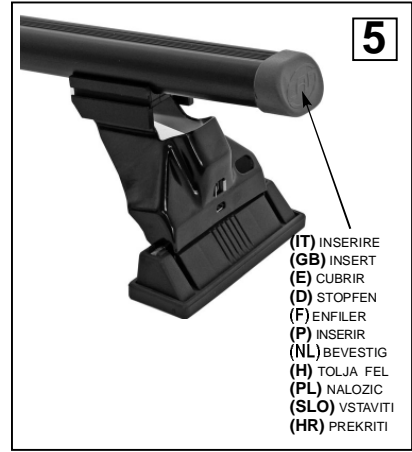
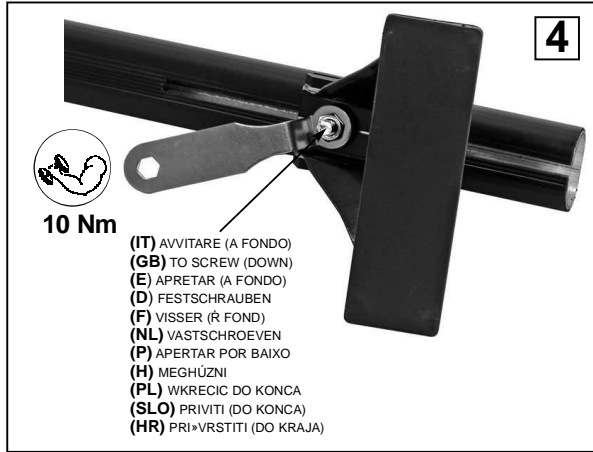
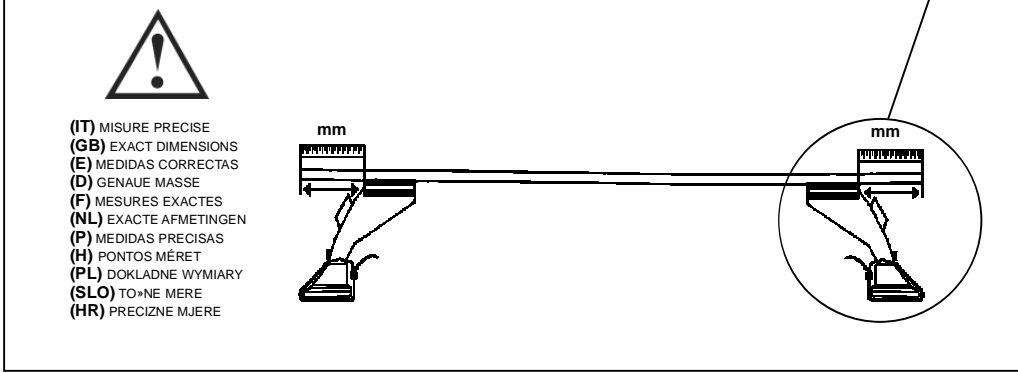

(IT) MODELLI SENZA PREDISPOSIZIONE DELLA CASA AUTO

(GB) CARS WITHOUT PRE-EXISTING FIXING POINT

(E) PARA COCHES SIN PREDISPOSICION DEL FABRICANTE

(D) AUTOS OHNE VOM HERSTELLER VORGESEHENE BEFESTIGUNGSPUNKTE

(F) VOITURES SANS POINTS DE RÉPÔRE PRÉVUS PAR LE CONSTRUCTEUR

(NL) AUTO'S ZONDER DOOR DE FABRIKANT VOORZIENE BEVESTIGINGSPUNTEN

(P) VIATURAS SEM PONTOS DE FIXAÇÃO DO CONSTRUTOR PRÉ-EXISTENTES

(H) FELHÉLYEZÉS GYÁRI JELŐLÉS NÉLKÜLI AUTÓKRA

(PL) SAMOCHODY BEZ PRZEWDZIANYCH PUNKTOW UMOCOWANIA

(SLO) MODELI Z NEPREDVIDENIM LEČIŠEM S STRANI PROIZVAJALCA

(HR) TVORNIŠKI NEPRIPREMLJENI MODELI



11

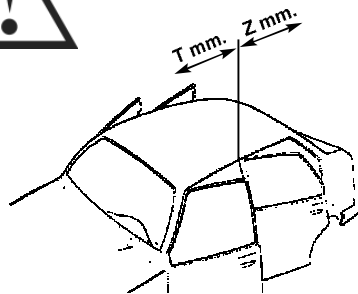

(IT) MODELLI AUTO

(GB) CARS

(E) COCHES

(D) WAGEN

(F) VOITURES

(NL) AUTO

(P) MODELO AUTO

(H) AUTÓ TIPUS

(SLO) MODELI AVTOMOBILOV

(HR) MODELI AUTA

(IT) ANTERIORE

(GB) FRONT

(E) DELANTERO

(D) VORDERE

(F) AVANT

(NL) VOORSTE G.

(P) R FRENTE

(H) ELSŐ RÚD

(SLO) SPREDAJ

(HR) PREDNJI

(IT) POSTERIORE

(GB) REAR

(E) TRASERO

(D) HINTERE

(F) ARRIERE

(NL) ACHTERSTE G.

(P) ATRÁS

(H) HÁTÓSÓ RÚD

(SLO) ZADAJ

(HR) STRAČNJI

	T	Z
CHEVROLET AVEO 4p. (06->11)	250 mm.	450 mm.
CHEVROLET LACETTI 4-5 p. (03->08)	270 mm.	380 mm.
DAIHATSU TREVIS	350 mm.	350 mm.
DAEWOO NEW NUBIRA (03->)	250 mm.	450 mm.
OPEL AGILA NO RAILS (<-07)	250 mm.	450 mm.
SUZUKI WAGON R NO RAILS	250 mm.	450 mm.

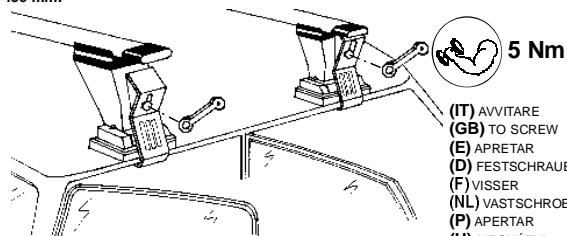

5 Nm

(IT) AVVITARE

(GB) TO SCREW

(E) APRETAR

(D) FESTSCHRAUBEN

(F) VISSER

(NL) VASTSCHROEVEN

(P) APERTAR

(H) MEGHÚZNI

(PL) WKRECIĆ

(SLO) PRIVITI

(HR) PRIVRSTITI

